

GREEK PROSODIES AND THE NATURE OF SYLLABIFICATION

by

Donca Steriade

Licență în Filologie, Universitatea din București
(1974)

M. A., Université Laval
(1976)

SUBMITTED TO THE DEPARTMENT OF
LINGUISTICS AND PHILOSOPHY
IN PARTIAL FULFILLMENT OF
THE REQUIREMENTS FOR
THE DEGREE OF

DOCTOR OF PHILOSOPHY

at the

MASSACHUSETTS INSTITUTE OF TECHNOLOGY

September 1982

© Donca Steriade 1982

The author hereby grants to M.I.T. permission to reproduce and to
distribute copies of this thesis document in whole or in part.

Signature of author _____

Department of Linguistics and Philosophy
September 1982

Certified by _____

Morris Halle
Thesis Supervisor

Accepted by _____

Samuel Jay Keyser
Chairman, Departmental Graduate Committee

MASSACHUSETTS INSTITUTE
OF TECHNOLOGY

DEC 3 1982

Hum.

GREEK PROSODIES AND THE NATURE OF SYLLABIFICATION

by

DONCA STERIADE

Submitted to the Department of Linguistics and Philosophy on
September , 1982 in partial fulfillment of the requirements
for the Degree of Doctor of Philosophy

This thesis presents an autosegmental approach to certain prosodic phenomena of Ancient Greek: vowel length, geminate structures, aspiration, syllabic assignments. The Greek material--supplemented by Sanskrit and Latin--is used to develop a framework for the description of syllabification processes.

I claim that phonological strings are syllabified by a sequence of syllabic incorporation rules: a universal rule pairing of CV sequences into core CV syllables, followed by language-specific rules that incorporate into these syllables more of the neighboring segments. I claim that complex onsets and branching rimes are created by such language-specific syllable adjunction rules.

I show that differences among the syllable structures of Latin, Greek and Sanskrit can be described as having two sources: different ordering relations among the syllable adjunction rules and different conditions on the relative sonority of adjacent tautosyllabic consonants. The latter parameter turns out to predict both the differences between the constraints on clustering in Greek and Sanskrit and the number of consonants each of these languages allows in the onset.

The relatively complex syllable structure of Greek is shown to require no reference to syllabic constituents other than onset and rime. The possible evidence for syllabic nodes other than onset and rime is shown in fact to be evidence for intermediate partially syllabified strings containing unaffiliated segments.

Thesis Supervisor: Morris Halle

Title: Institute Professor

To my parents, Mircea and Ștefana.

ACKNOWLEDGMENTS

Neither my teacher , Morris Halle, nor the other members of my committee, Jay Keyser and Paul Kiparsky, agree with everything that follows.

But, having done my duty to clear their names, I should add that I owe them the better part of the thesis : I could not have written anything resembling this four years ago.

I am indebted to Morris Halle for many of the ideas that directly or indirectly contributed to the final product, but, perhaps more importantly, for being interested in becoming a full participant in my research. I can recall few moments as gratifying as Halle's phone calls to announce that he has found a solution to a problem I had or that he has discovered a problem for a solution I proposed. I regret leaving MIT at a point when even disagreement with him has become so intellectually rewarding.

I have learned in the last six years a significant amount from reading Paul Kiparsky's works and later from talking to him. His influence on this study, even when not visible to the naked eye, has been considerable: many ideas which the reader will be happy to have been spared were eliminated in response to his criticism. The sonority scale proposal and the analysis of Greek resyllabification types have originated in discussions with him , continued after the end of the appointment by me alone, playing both parts.

I have also profited from discussing my work with Jay Keyser, and from studying his joint work with Nick Clements: my renewed interest in the skeleton can be traced back to the first reading of

their 1981 paper. I also owe Keyser many improvements in presentation.

I am grateful to Anna Morpurgo Davies for her fall 1977 seminar on Mycenaean at Yale, which proved invaluable in chapter 4. And to Warren Cowgill for keeping my interest in Indo-European alive.

I should also mention the contribution of the team who taught me Greek and Indo-European at University of Bucharest: Francisca Băltăceanu, Iancu Fischer, Lia Lupas, Petru Creția.

To my friends at MIT I owe what inspires us all to write such lengthy acknowledgments : four years of intellectual discoveries , political debates, gossip, mutual kibbitzing, moral support and a sense of principled solidarity. I am thinking of Jane Simpson, David Nash, Alec Marantz, Anne Rochette, Juliette Levin, Isabelle Haïk, Carol Neidle, Ken Safir, Luigi Burzio, Hagit Borer, Tim Stowell, Maria-Luisa Zubizarreta and, among the transients, Mihaly Brody, Pino Longobardi and Eric Reuland.

David Pesetsky, my oldest friend in the Yale Seminar room and in building 20, spread the gospel of the Indo-European onset with enthusiasm worthy of special thanks.

Barry Schein, a hostage to this thesis for the last month or so, has contributed ideas (he is the spiritual father of the section on geminates), clerical work, advice on the logic of many arguments, packaging skills, stylistic help and much unsolicited kugel. If I succeed in graduating this year it will be thanks to him.

Maggie Carracino has typed a manuscript with too many raised h's with remarkable grace. Doug Pulleyblank, Juliette Levin , Anne Rochette and Isabelle Haïk have contributed their proofreading skills.

Over the last eight years, my father, Mircea Steriade, has been a close friend, a generous NSF, the most reliable source of moral support. I cannot thank him enough.

TABLE OF CONTENTS	PAGE
ABSTRACT	2
ACKNOWLEDGMENTS	4
INTRODUCTION	8
CHAPTER I The Framework	13
1. Tiers of Representation	13
1.1. Introduction	13
1.2. Skeleton/Core relations	14
1.2.1. Contour Segments	17
1.2.2. Geminates	27
1.3. Linked Matrices	41
1.3.1. The Autosegmental Theory of Assimilation Rules	41
1.3.2. Geminates in the Output of Partial Assimilation Rules	47
1.3.3. Partially Assimilated Clusters and Constraints on Geminates	52
1.3.4. The Need for a Shared Features Convention	67
2. Melody--Skeleton--Syllable Mapping	70
3. Syllable Structure and Syllabification	72
3.1. Onsets and Rimes	72
3.2. Syllabic Parsing	74
3.2.1.	74
3.2.2. A Proposal	78
3.2.3. Core Syllable Rules and Stray Segments	84
3.2.4. Ordering Constraints	86
3.3. Exhaustive Syllabification and Stray Erasure	89
3.4. The Sonority Hierarchy	91
4. Lexical Phonology	100
FOOTNOTES	102
CHAPTER II Compensatory Lengthening and Resyllabification Types in Greek	113
1. Introduction	113
2. Compensatory Lengthening and the Empty Node Convention	114
3.1. Loss of <u>w</u> in Ancient Greek	117
3.2. The Formal Statement of CL and of Resyllabification	125
3.2.1. The Interaction of Resyllabification and CL	126
3.2.2. CL, Degemination and Resyllabification	134
3.2.2.1. Degemination	136
3.2.2.2. Why Degemination does not trigger CL in Greek	139
3.2.2.3. Formulating CL without a Skeleton	142
4. CL after <u>s</u> -Deletion	146
4.1. The Analysis	146
4.2. Sonorant- <u>h</u> Metathesis	149
4.3. The Autosegment <u>h</u>	154
5. Conclusion	163
FOOTNOTES	168

CHAPTER III Attic Syllable Structure	
1. Introduction	175
2. Evidence for Syllabification in Attic	178
3. Syllabic Divisions in the Attic prosody	186
4. Reduplication	195
5. Syllable Structure and Cluster Simplification	209
5.1. Introduction	209
5.2. Possible Clusters and their Distribution	210
5.3.1. Cluster Simplification	216
5.3.2. The Minimal Sonority Difference in Attic	218
5.4. The Segmental Linking Condition	223
5.5. Underlying Clusters and Segmental Linking Rules	230
5.5.1. Laryngeal Features Assimilation	230
5.5.2. The Grammar of Aspiration in Attic	233
5.5.2.1. Grassmann's Law	234
5.5.2.2. Aspiration Assimilation and Bartholomae's Law in Greek	237
5.5.2.3.	239
5.5.3. Coronal Clusters	249
5.5.4. Labial Clusters	252
5.5.5. <u>Y</u> -Clusters in Attic	261
5.6. <u>Excursus</u> : the Heterosyllabicity Condition	272
5.7. Back to the Segmental Linking Condition	278
6. The Order of Syllabification Operations	285
FOOTNOTES	293
CHAPTER IV The Structure of Heterosyllabic Initials	
1. Introduction	301
2. Heterosyllabic Initials in 1st Millenium Greek	304
2.1. Reduplication	304
2.2. Loss of Interconsonantal <u>s</u> , Resyllabification and Reduplication	308
3. Heterosyllabic Initials in Sanskrit	312
3.1. Reduplication	312
3.2. Loss of interconsonantal <u>s</u>	328
4. Heterosyllabic Initials in 2nd Millenium Greek	333
4.1. Mycenaean Spelling Conventions	333
4.2. The <u>s</u> — <u>h</u> Rule in Common Greek	340
4.3. Archaic Reduplications	350
5.	353
6. Syllabification across Major Boundaries	355
7. Clusters across Major Boundaries, Adjunction Rules and the Stray Erasure Convention	361
FOOTNOTES	373
BIBLIOGRAPHY	380

Introduction

The term prosody in the title of this study has the meaning of Greek προσῳδία : any normally unwritten but phonologically relevant aspect of the utterance. I present here an account of several prosodic aspects of Ancient Greek phonology, centered around but not limited to the system of syllabification rules. They include an analysis of geminate structures, vowel length, aspiration, Compensatory Lengthening and the syllabic assignment of consonant clusters within words and within phrases. They also turn out to include a component of the phonology not usually conceived of in prosodic terms : the segmental assimilation rules. The emphasis is on the import of these subsystems of the phonology for the analysis of syllabification.

The framework assumed here is that of generative phonology enriched with the autosegmental representations introduced in recent work by McCarthy (1979), Halle and Vergnaud (1982), Clements and Keyser (1982). My goal is not that of testing against the Greek facts an established framework of description : rather this study is aimed at a number of points on which the autosegmental framework I adopt is still in a state of flux. Greek evidence is introduced as relevant to unsettled issues such as the formal statement of segmental assimilation rules, the description of Compensatory Lengthening effects, the existence of syllabic constituents other than the onset and the rime , the mechanisms involved in syllabifying and resyllabifying a string.

The central thesis which organizes this work is : not all aspects of syllabic organization are determined simultaneously , at the same point in the phonological derivation or in the cycle. By this I mean that some

aspects of the syllabic structure of Greek are defined by rules which are extrinsically ordered late in the derivation, long after most segments have been assigned to a syllable. We will see that, in fact, the syllabification system of Greek favors a more radical conclusion : syllabic structures are created by syllable building rules ordered among the rules of the phonological component, subject to the same conventions on rule ordering and application as any other metrical rule.

Chapter 1 gives an overview of the version of autosegmental phonology assumed in later chapters, much of it based on the ideas presented in Halle and Vergnaud (1982) and in the antecedents of that work: McCarthy (1979), Prince (1980), Marantz (1982). Chapter 2 establishes that consonantal segments deleted in Greek in coda position lead to the compensatory lengthening of a preceding nuclear vowel. Chapter 3 builds, in part on this conclusion, an account of the word level syllabification processes of Attic. Chapter 4 analyzes the syllabic derivation of the consonants left unaffiliated by word level syllabification rules.

Some of the results obtained here are negative, in the sense that they show why certain approaches to syllabification or related processes are inadequate. I thought it important to demonstrate not only how the analyses advocated here work but also why alternatives proposed in recent work - or conceivable alternatives - are less satisfactory. This has made the presentation somewhat more cumbersome, as the alternatives must be developed and made precise when difficulties emerge. In particular, I have tried to avoid the relatively easy solution of rejecting an analysis proposed elsewhere when it fails for purely mechanical reasons, which leave its leading idea intact. Whenever possible, I tried to show that a rejected

proposal fails by reason of fundamental inadequacy rather than incorrect formalization. But all this has required developing in some detail ideas that were ultimately rejected. I hope that the price paid in ease of exposition is justified by the gain in understanding what exactly differentiates some of the recent approaches to syllabification compared here.

Because not all of Greek phonology is relevant to the issues discussed, I did not attempt a full account of the phonology of Attic or of any other dialect. Underlying forms are posited either with full justification - when all rules mapping them to the surface forms are discussed - or by decomposing surface forms into their underlying grammatical formatives. The decisions on what is a root and what is an affix are - I believe - so uncontroversial that anyone in possession of a Greek grammar and dictionary would have reached them. For this reason I have frequently left out the evidence usually cited as justifying a certain underlying form, such as alternants in an inflectional and derivational paradigm.

In one case I have frequently abstracted away from a phonological rule which sets Attic-Ionic apart from other Greek dialects : the raising of long ā to long lax ē. As this process plays no role in the system of rules discussed here, and because it obscures the output of some phonological and morphological processes, as well as some basic similarities between Attic-Ionic and other dialects, I have sometimes listed as Attic or Ionic intermediate forms like āngēla instead of the surface ēngēla. With this one exception, what I list as surface forms are the transliterations of the written record. Improvements on how that record should be interpreted are proposed in chapter 3.

The system of transliteration adopted from the beginning is as follows : (a) The rough breathing as well as the aspiration feature of stops is represented as a superscript h . In autosegmental representations the notation [h], [v], [-v] stands for [+spread glottis], [+voiced] and [-voiced] respectively. Thus

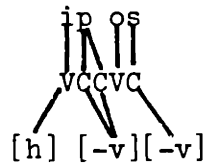

is a partial autosegmental representation for ἵππος, transliterated linearly as hippos. The [h], [v] notation also replaces the lengthier [+spread glottis], [+voice] in writing rules. The voicing and aspiration features of stops and vowels are represented autosegmentally, as above, only when the structure of the laryngeal tier is relevant to the point at hand.

(b) On a full autosegmental representation, which includes indications of syllabic structure, the two-dimensional page offers no way of representing more than three tiers without crossing association lines . Thus in

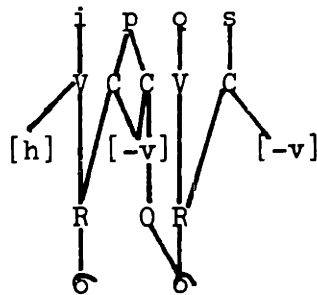

O,R stand for Onset and Rime.
σ stands for Syllable.

there is no graphic solution to the problem of representing the laryngeal tier without having its association lines cross those of the syllabic tier.

The reader should understand that, unless two lines link the same two tiers, they cannot cross in the technical sense.

(c) Vowel length is represented by a superscript macron in linear representations. Tense long mid vowels are written \bar{e} , \bar{o} , lax long mid vowels are written \bar{e} , \bar{o} . The breve sign is sometimes used to underscore the fact that the vowel is short. Autosegmental representations for long lax vowels are $\begin{array}{c} x \\ \swarrow \searrow \\ v \quad v \end{array}$, x an arbitrary vocalic segment; for long tense

vowels they are $\begin{array}{c} x \\ \swarrow \searrow \\ v \quad c \end{array}$. This notation is justified in chapter 2.

(d) No distinction is made between the ei, ou diphthongs and the spurious diphthongs : from the point of view of the synchronic phonology of Attic the distinction does not exist and all relevant nuclei are tense mid long vowels.

(e) No account is taken of either the rough breathing of initial r's or of the smooth breathing of initial vowels. Accent indications are likewise omitted.

(f) The songs in the homeric poems are referred to by letters transcribing the units of the Greek alphabet, in the sequence of the Greek alphabet. Capitals are used to denote songs in the Iliad, lower case letters for songs in the Odyssey. Thus D 434 is a reference to line 434 of the 4th song of the Iliad; ps 5 refers to verse 5 of the 23rd song of the Odyssey.

All other notational conventions used here are standard.

Chapter 1 : The Framework

1. Tiers of representation

1.1. Introduction

Since the appearance in 1976 of Goldsmith and Kahn's dissertations the representations assumed in generative phonology have been enriched in two respects: Goldsmith introduced the idea of separate tiers, the tonal and the segmental, running simultaneously and specifying distinct aspects of the phonological sequence. Kahn extended this approach to describe syllabic organization; he argued that the syllable had to be recognized as a unit of description and that its best characterization was in terms of autosegmental units rather than as segment sequences contained between syllable boundaries.

Both ideas proved fertile. The separate tier line of research led to important work in the area of vowel harmony (Clements 1977, 1980) and morphology (McCarthy 1979, Marantz 1982). The introduction of a prosodic approach to syllable structure led to the view that syllables are simply phonological constituents (cf. Kiparsky 1979, McCarthy 1979) on a par with the metrical constituents by which Liberman and Prince (1977) proposed to encode accentual prominence. Later work by Rotenberg (1978) and Mohanan (1982) eliminated the possibility of dealing with syllable dependent processes by introducing syllable boundaries (as in Hooper 1972). Rotenberg and Mohanan argued persuasively against the conception of morphological boundaries as entities similar to segments, which can be inserted, put in parentheses, deleted: they demonstrated that reference to boundaries can be successfully superseded by reference

to morphological and syntactic constituent structure. This removed whatever appeal syllable boundaries, as opposed to syllabic constituents, still had.

The theory of phonology adopted in this study is based on the idea of separate tier representations and on that of phonological constituents like syllables or metrical trees. The present chapter will give a detailed inventory of the specific assumptions associated with these ideas. I begin by reviewing and augmenting the evidence for a distinction between the tier specifying syllabicity distinctions and the one carrying the actual segmental information: I will refer to the first as the skeleton, adopting the term introduced by Halle and Vergnaud (1982); I will call the second the melodic core, sometimes abbreviated as the core, which should invite the appropriate associations with Goldsmith's tonal melodies. The units forming the skeleton will be referred to as C or V slots; the units of the melodic core will be called segments, as they most closely approximate the traditional notion of segment. The adjectives melodic or segmental will be used interchangeably to refer to information specified on the melodic core.

1.2 Skeleton/core relations

The initial arguments in favor of separating the segmental and the syllabic information which form a phonological string were presented in McCarthy 1979, a study of the word formation processes of Semitic: McCarthy showed that the problem of discontinuous morphemes, endemic in Semitic but not restricted to that family, could

be solved by allowing morphological information to be carried by distinct but simultaneous aspects of the phonological string. Most of the segmental content of a word's consonantism identifies the root, while the sequence of consonants and vowels on which the segmental content is realized provides derivational and inflectional information. Representations like the one in (1) were thus motivated:

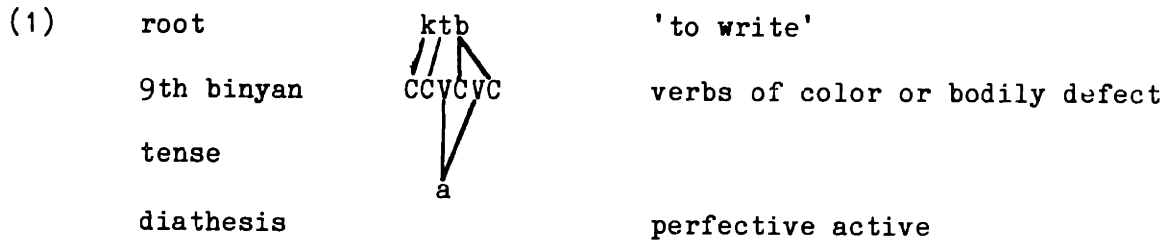

linear representation: ktabab

The association of the various morphemes, ktb, CCVCVC, a, was brought about by association conventions identical to those motivated for the description of tonal phenomena by Goldsmith (1976):

- (2) Well-formedness Condition
- a. Every unit on one level must be associated with at least one unit on every other level.
 - b. Association lines may not cross.

In addition, a specific mapping procedure, given in (3), was necessary in order to characterize the results of associating a binyan with n C slots with a consonantal root containing fewer than n consonants:

(3) Consonant Association

Autosegments are associated from left-to-right with appropriate slots of the template. Formally,

Template	C	C	C
Melody	x	y	z

(McCarthy 1979 :251)

The application of (3) to the mapping of a trilateral root like ktb onto a quadriconsonantal binyan like CCVCVC requires that the last root segment, b, be doubly associated, as shown in (1). Right to left association would have resulted in *kkatab, *kkaatab, *kkantab. The necessity of (3) is of some interest since, as McCarthy notes (1979 :251) and as shown by Williams (1976), tone mapping rules have the same left-to-right directionality. We shall see below that syllabic parsing also takes place from left to right.

Following McCarthy, Marantz (1982), Halle and Vergnaud (1980), Yip (1982) showed that the analysis of word formation processes like reduplication and broken plurals as well as that of secret languages was significantly simplified by the assumption of the skeleton/core dichotomy. Some of Marantz's results will prove useful in Chapter 3.

Recently, evidence of a purely phonological character in favor of tiered representations like (1) has begun to surface. I will mention here two types of arguments to this effect, both modeled on the demonstration, made by Williams and Goldsmith, of the independence of the tonal tier from what was then seen as the undifferen-

tiated segmental tier. I discuss first two cases of proposed contour segments, a term which, by analogy to contour tones, is introduced here to refer to structures like (4)<1>:

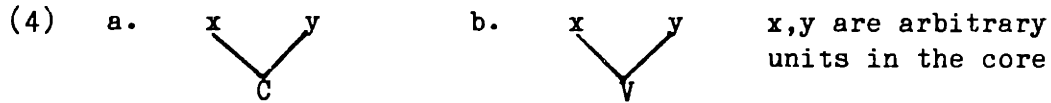

I then consider the reverse type of many-to-one mapping, shown in (5),

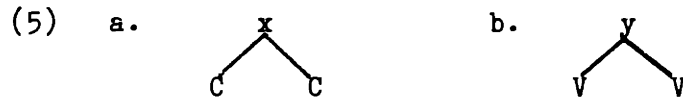

and successfully used by Schein (1981), Hyman (1982) and Kenstowicz (1982) in their analysis of geminate segments.

1.2.1 Contour segments

In earlier work (Steriade 1982) I have proposed the following representations for Latin labiovelars:

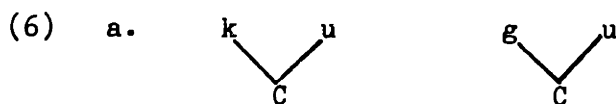

The monoconsonantal nature of these sounds, traditionally spelled qu, gu, is amply documented by Devine and Stephens (1977): they are the only consonant clusters which fail to close a preceding syllable in all periods and poetic styles of Latin. In this they contrast with stop-liquid clusters, which, in the classical and postclassical poetry may be counted as heterosyllabic. The bisegmental character

of the Latin labiovelars -- the fact that each labiovelar consists of two melodic units -- is revealed by their distribution: they can occur only in prevocalic position, unlike any other consonants.

This restriction follows from the fact that Latin, a language where word internal syllables obey the Sonority Sequencing Generalization^{<2>}, cannot syllabify exhaustively any sequence stop - w - consonant. Two treatments are attested for the underlying labiovelars

trapped in pre-consonantal position: the labiovelar may lose its labial component, as in coctus 'cooked' underlying koku-tos, or as

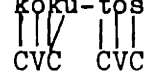

in nec 'neither' the apocopated version of neque^{<3>}. Or the labial

glide may syllabify as a vowel, as in secutus 'followed', underlying

seku-tos, lingula 'little tongue', underlying lingu-la^{<4>}. Two rules

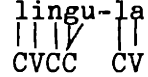
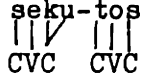

are necessary to account for preconsonantal labiovelars: rule (7)

applies to a stray labiovelar, a segment that could not be assigned

to any syllable because of the resulting violation of the Sonority

Sequencing Generalization ^{<5>}, and detaches the labial element:

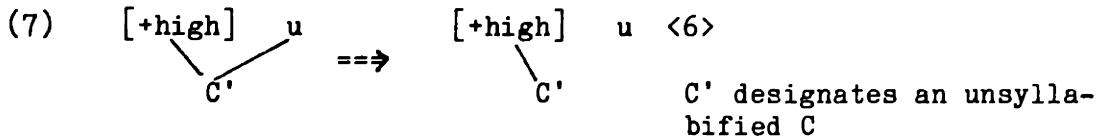

The application of (7) is illustrated below:

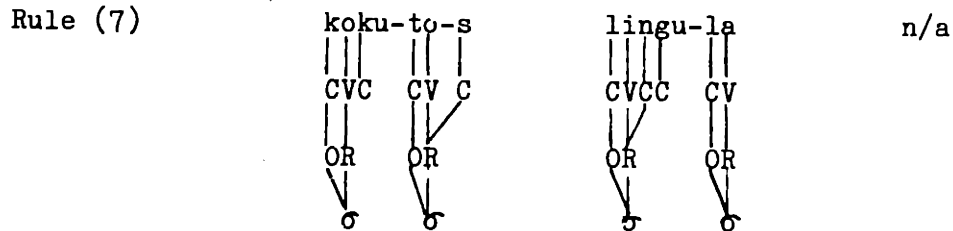
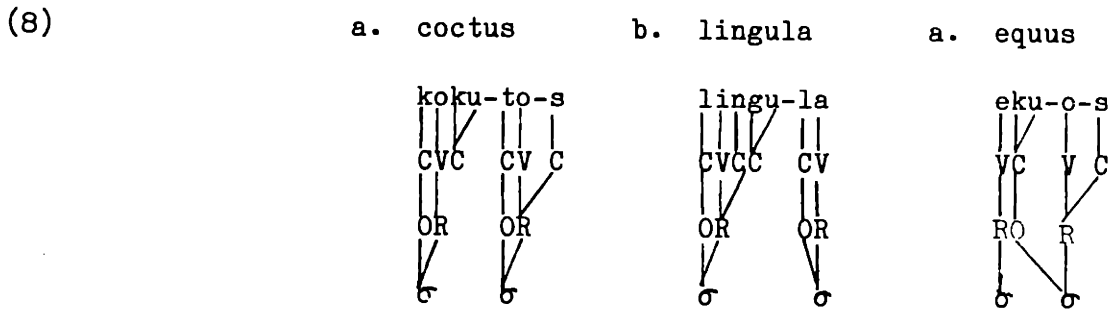

Rule (9) inserts a V slot and associates it with the floating segment u:

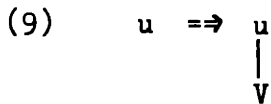

Some lexical items, like the root coqu-, are exceptions to (9). This is an indication that the rule is cyclic, in contrast with rule (7), which admits of no exceptions. Let us assume then that the apocope in nec, a postcyclic rule, can be followed by rule (7), which applies both cyclically and postcyclically: but that it cannot be followed by rule (9), a cyclic rule. (On the notion of cyclic rule assumed here see section 4). Thus rule (9) will fail to apply both in items like coctus, which are lexical exceptions to it and in items like nec, where the environment which could meet (9) has been created at a point in the derivation when (9) is no longer

applicable. For this reason the u set afloat by (7) in such forms will remain unassociated and will fail to surface. The complete derivations of coctus, lingula and nec are given in (10) below:

(10)

2nd cycle

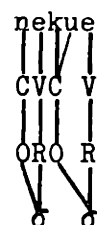
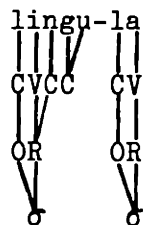
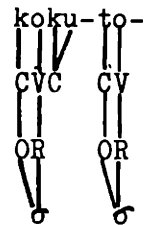

rule (7)

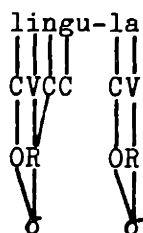
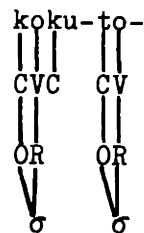

n/a

rule (9)

koku-to-
[-rule 9]

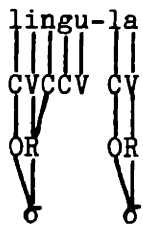

n/a

syllab.	<p>koku-to-</p>	<p>lingu-la</p>	n/a
erasure of stray material	<p>kok-to-</p>	n/a	n/a
output of cyclic phonology	<p>koktus</p>	<p>lingula</p>	<p>neku</p>
postcycle	n/a	n/a	<p>neku</p>
apocope	n/a	n/a	<p>neku</p>

rule (7)	n/a	n/a	neku CVC OR σ
----------	-----	-----	---

syllab.	n/a	n/a	neku CVC OR σ
---------	-----	-----	---

erasure of stray material	n/a	n/a	nek CVC OR σ
---------------------------------	-----	-----	--

The role that syllabification plays in (10) deserves mention. I have conflated in the application of syllabification at the end of the second cycle two operations: the creation of a syllable from the stray units CV in lingula and the adjunction of the stray C as the coda in the first syllable of coctus. I have assumed that stray melodic material is erased in the output of cyclic phonology and then again at the end of the derivation: the evidence for placing this operation in the cycle will be given in Chapter 4. Finally, I have entered as the input to the second cycle partially syllabified structures like:

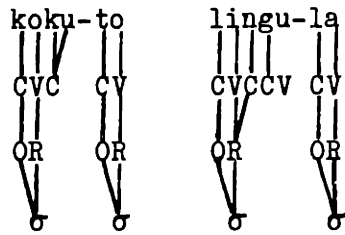

I attribute the failure of (7) to apply to the cycle final stray labiovelars on the first cycle, which would result in

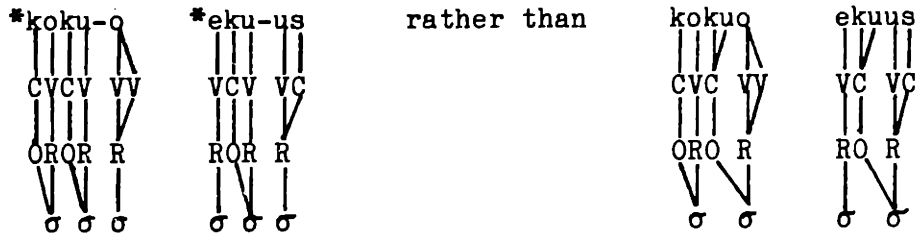

to the fact that cycle final C's are extrametrical in Latin. The notion of extrametricality employed here is an extension of the mechanism motivated by Hayes (1982) for stress rules; its application to syllabification processes will be explored in Chapter 4.

Thus the stray labiovelars of

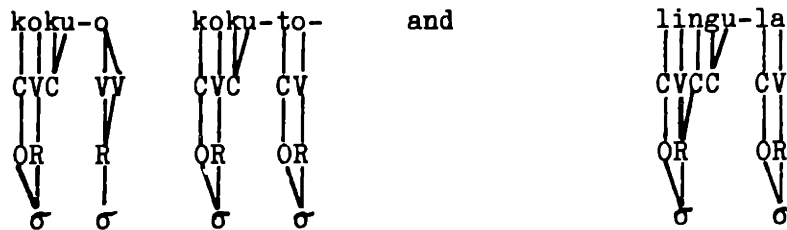

become subject to syllabification rules and to rule (7) only on the second cycle, when they cease to be extrametrical because they cease to be cycle final.

We have seen that the monoconsonantal labiovelars of Latin sur-

face sometimes as velars and sometimes as [velar] u sequences, where the labial element has full syllabic status. This is the evidence for their bisegmental nature and in favor of the representations in (6).

The other example of a contour segment that I will mention appears in Keyser and Kiparsky (1982), a study of the interaction between syllabification and segmental rules in Finnish. Keyser and Kiparsky begin by showing (a) that Finnish allows no VV sequences in unstressed syllables; and (b) that Finnish, a language in which primary stress falls on the initial syllable, has an optional secondary stress on the third syllable. The optional secondary stress and the VV prohibition are then shown to interact in ways which suggest that some unstressed diphthongs are contour segments in the sense defined in (4) above. The rules which test the monovocalic behavior of the Finnish diphthongs in question are t-Deletion, a rule which deletes t after an unstressed light syllable ((11) below), and Consonant Gradation, which degeminates a geminate stop and lenites a non-geminate stop before a heavy rime. I repeat the informal statement of Consonant Gradation given by Keyser and Kiparsky in (11):

(11) t-Deletion

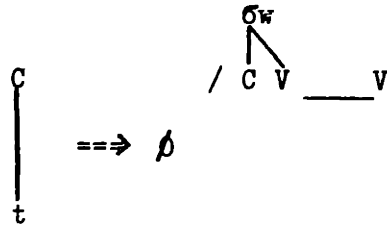

(12) Consonant Gradation

p, t, k weakened

pp, tt, kk degeminated / [+son] ___ V

Consider now a form like /talo-i-ta/ 'house-PL-partitive'. It surfaces consistently as taloja, a sequence of three light syllables; this means that the underlying sequence oi has been assigned a single V slot, in accordance with the fact that a second syllable cannot receive either primary or secondary stress, and therefore must not contain a VV nucleus. taloita, syllabified as



can now undergo t-Deletion since the syllable preceding t is both unstressed and light. When the diphthong occupies the third syllable the optional secondary stress produces variants like those recorded in (13):

(13)	arvelu-i-ta	arveluja	'surmise-PL-partitive'
		arveluita	
	mellakka-i-ta	mellakkoja	'riot-PL-partitive'
		mellakoita	
	mellakka-i-na	mellakoina	'riot-PL-essive'
		mellakkoina	

Arveluja results when the third syllable is not stressed; underlying ui must then be assigned a single V slot, to comply with the prohibition on VV sequences in unstressed syllables and, as a result, t deletes. If the third syllable is stressed then ui can be syllabified as a VV nucleus and t-Deletion is blocked, yielding arveluita. Mellakkoina, showing no effects of Consonant Gradation, results from the failure of the secondary stress to the third syllable: the oi diphthong in an unstressed syllable must occupy a single V slot, hence a light third syllable, before which Consonant Gradation is inapplicable. Mellakoina is derived if secondary stress does apply to the third syllable, permitting the creation of a VV rime oi,

$$\begin{array}{c} \text{oi} \\ \text{VV} \end{array}$$
which, in turn, triggers Consonant Gradation. The heavy rime oi in

$$\begin{array}{c} \text{oi} \\ \text{VV} \end{array}$$
mellakoita, sanctioned by the assignment of secondary stress, has the double effect of blocking t-Deletion and triggering Consonant Gradation. In the absence of the secondary stress, the third rime is compressed to oi,

$$\begin{array}{c} \text{oi} \\ \text{V} \end{array}$$
a structure which allows t-Deletion to apply but blocks Consonant Gradation: mellakkoja is produced in this way. Since this account succeeds in organizing a rather complex paradigm

and selects correctly the two attested variants of underlying forms like mellaka-i-ta out of the four logically possible outcomes, the assumptions on which it relies are also supported: in particular, the assumption that the surface diphthong in mellakkoina and the immediate input to t-Deletion in taloja, taloita contain contour segments:

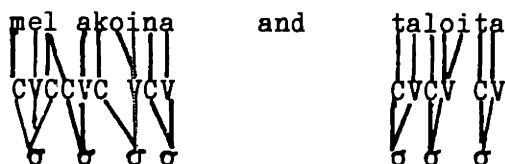

1.2.2 Geminates

The skeleton/core distinction allows analyzing geminate segments, consonants or vowels, as single melody units associated with two skeleton slots:

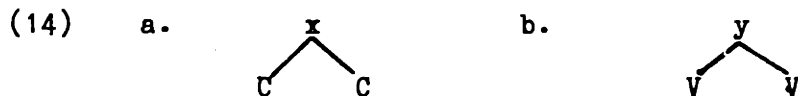

But, in the absence of further provisions<6>, a tiered representation of the phonological string will also permit sequences like those in (15):

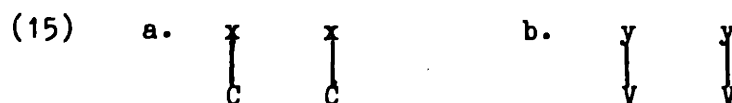

A linear model in which syllabicity distinctions are represented on the same tier with other feature specifications cannot differentiate

between (14) and (15).

This section has a dual task: it will establish that both representations like (14) and (15) are necessary, and will thus provide more reasons to adopt autosegmental representations. It will also explore the properties associated with the geminates in (14), henceforth called true geminates. These properties will serve as a test for any structures involving two or more skeleton units associated with the same melodic element. Such structures will play an important role in the analysis of Attic syllable structure developed in Chapter 3.

An investigation into the behavior of geminate consonants in Berber and Arabic led Guerssel (1978) to posit the following constraint:

(16) The Adjacency Identity Constraint (AIC)

Given a string $A_1 A_2$ where $A_1 = A_2$, a rule alters the adjacency of $A_1 A_2$ if and only if it alters the identity of A_1 or A_2 .

This constraint, formulated in a linear framework, had to account for what Kenstowicz and Pyle (1973) had termed "the integrity of geminate clusters": geminate consonants cannot be split by epenthesis (which would alter their adjacency without altering their identity) nor can one half of the geminate segment undergo a rule which the other half does not undergo (this would alter the identity of the cluster without altering the adjacency of its members). The geminate integrity hypothesis, as formalized by Guerssel, predicted

that only one type of rule could apply to a geminate cluster: degemination, a process which would simultaneously alter the identity of the cluster and the adjacency of its members. This prediction was to some extent disconfirmed by Guerssel's own discovery that some heteromorphic geminates do not obey the AIC: namely, the heteromorphic geminates that had not undergone any assimilation rule. For example, both Algerian and Moroccan Arabic have identical rules of coronal clusters voicing assimilation and epenthesis between the first two members of a triconsonantal cluster. In Moroccan the voicing assimilation rule applies before epenthesis, leading to derivations like (17):

(17)	Assimilation		Epenthesis	
t-ktəb	n/a	təktəb	'you write'	
t-dir	ddir	n/a	'you do'	
t-ḍrəb	ḍḍrəb	BLOCKED by the AIC	'you hit'	
t-tləg	tṭləg	BLOCKED by the AIC	'you release'	

In Algerian, however, the epenthesis rule applies before voicing assimilation: it therefore encounters in the forms corresponding to those in (17) heteromorphic clusters to which no assimilation rule has applied. Such clusters, even when they involve geminates, as /t-tləg/ does, do not block epenthesis:

(18)	Epenthesis	Assimilation
t-kt ə b	təkt ə b	n/a
t-dir	n/a	ddir
t-dr ə b	t ə dr ə b	n/a
t-ɬl ə g	t ə ɬl ə g	n/a

To reconcile the Algerian facts with the AIC, Guerssel assumed that assimilation rules, like the coronal clusters voicing assimilation, had the effect of erasing morphological boundaries. A heteromorphic geminate cluster would fail to be a geminate in the sense of the AIC since, in the phonological framework assumed by Guerssel, the intervening morpheme boundary would make the two consonants non-adjacent. Thus, as long as the morpheme boundary would be there, the AIC could not block epenthesis from applying to such clusters and the facts of Algerian would follow. If, however, an assimilation rule applied before epenthesis, as is the case in Moroccan, the morpheme boundary would be erased and the cluster of identical segments would become a geminate subject to the AIC: epenthesis would then be blocked.

In a linear framework, Guerssel's AIC played a role analogous to that of the strong and weak clusters in the SPE linear analysis of stress<7>: it was a nearly correct characterization of the exceptional behavior of geminate clusters but the very need for a rather odd condition like the AIC pointed to an inadequacy within the theory. The necessity to add to this condition the otherwise unmotivated boundary erasure convention was one more symptom that

the linear theory itself had to be revised. In presenting an autosegmental account of the typology of geminates, I will continue to refer to the AIC as the best statement available within a linear framework for the pretheoretical proposition:

(16') Geminates cannot be split.

In what follows we will explore both the coverage, left open, of (16') and its correct formal statement.

Since Rotenberg (1978) and Mohanan (1982) have eliminated boundaries as a means to delimit morphological units, it would seem that the members of a geminate cluster are as much adjacent when they belong to the same morpheme as when they belong to distinct and adjacent ones. The essentials of Guerssel's account of Moroccan and Algerian epenthesis can, however, be maintained under an autosegmental analysis of geminates: different morphemes like the 2nd sg. prefix t- and the root tləg will have to be entered as distinct segments with distinct associated skeleton slots in the lexicon. When concatenated, the morphemes will yield a sequence

t-tləg
| | | |
C CCVC

which does not contain a true geminate cluster, in the sense defined above in (14). Suppose now that (16') applies to true geminates only: we would then predict that, in the absence of any rule, heteromorphic geminates will not be subject to (16'). The pattern of Algerian epenthesis will then be explained. To account for the facts of Moroccan, we will assume for the moment that the coronal

cluster voicing assimilation rule is a gemination rule taking the form of (19):

$$(19) \quad \begin{array}{c} [+cor] \\ | \\ C \end{array} \quad \begin{array}{c} [+cor] \\ | \\ C \end{array} \quad \Rightarrow \quad \begin{array}{c} [+cor] \quad [+cor] \\ \diagdown \quad | \\ C \quad C \end{array}$$

Since in Moroccan (19) applies before epenthesis, the true geminate created by (19) will be prevented by (16') from undergoing epenthesis. We have thus established the usefulness of the distinction between structures like (15.a) and (14.a): they correspond to the initial cluster of /t-tl ə g/ before and after rule (19). The distinction is not available in a linear framework.

The argument on which this reanalysis of Guerssel's data was modeled appeared in Schein (1981) and was later discovered independently by Kenstowicz (1982): it involves the blockage of the rule of Spirantization in Tigrinya. Spirantization, formulated by Schein as in (20), applies to any postvocalic velar stop at the postcyclic level:

$$(20) \quad [+cons, +back] \Rightarrow [+cont] / V \underline{\quad}$$

Some examples are: d ə kām 'weakness' zākti 'now' gäza-ka
'house-yours' m ə b ə rak 'bless'. (20) fails, however, to apply to some geminate clusters: tautomorphic geminates like those of fäk-kärä 'boast-3m sg., perfect', räqqiq 'thin', qätälä-kka 'kill-3msg.perfect-pron. 2msg.' as well as the geminates created across morpheme boundaries by the operation of gemination rules like those of

y ə bar ə kko 'bless-3msg jussive' (underlying /y ə bar ə k- o/),
 CV CVC VC CV

b ə räkka 'bless-2m sg.imperative-pron.3f' (underlying b ə räk- a).
 CV CVC CV

We can attribute the blockage of Spirantization in these examples to the effects of (16'). We assume that in lexical representations languages select the least marked of the two possible geminate structures, namely (14.a). As a result, tautomorphemic geminates should consistently take the form of true geminates, as they do in Tigrinya. For the justification of the derived true geminates of Tigrinya I refer the reader to the paper cited. After showing that both derived and underlying true geminates fail to undergo Spirantization, Schein shows that heteromorphemic geminates resulting from the juxtaposition of identical velar stops do undergo (20): one example is baräk-ka 'you-blessed-2m sg perfect' which contrasts minimally with bəräkka, cited above. As in the case of the Algerian example, an autosegmental analysis coupled with the most natural assumptions about the form of lexical entries will appropriately distinguish between

baräk-ka
 ||||| ||
 CVCVC CV

and

barak-a
 ||||| |
 CVCVCCV

and predict that only the latter will block (20).

Having demonstrated the merits of a two-tiered representation of geminate clusters, we may now turn to a closer examination of the constraint on splitting geminates. The facts discussed above

require that such a constraint recognize the distinction between true geminates and adjacent identical segments<8>. But a simple reformulation of (16') as

(16'') True geminates cannot be split.

is intuitively unsatisfactory: having observed that the clusters to which (16') applies take the form of branching segments

(21)



```
graph TD; x --> c1[c]; x --> c2[c];
```

it seems that the facts recorded by this constraint ought to follow from the structure of true geminates. I will make here two suggestions, whose joint effect is to cover most of the facts covered by Guerssel's AIC. The residue of cases where my proposals will make different predictions will then be discussed.

Let us begin with the blockage of a rule like Spirantization when a true geminate cluster is encountered. Facts like those of Tigrinya have been recorded earlier by Kenstowicz and Pyle (1973) (a methathesis rule in Kasem fails to apply to the first half of a geminate u) and will be encountered in Chapter 4 of this study (a rule which turns syllable initial g into h in prehistoric Greek fails to apply to the second half of a geminate g). Some, if not all, of the rules involved have multiple foci. Suppose that we followed the practice established in SPE<9> to mark [+rule n] each of the segments meeting the structural description of any given rule n and added that segments not meeting the structural description of rule n

are marked [-rule n]. Consider now an item like Tigrinya

fäk ära .
 |||
 CVCCVCV

The environment of Spirantization is met by the first C slot associated with the velar but not by the second one. K will be marked both [+Spirantization] and [-Spirantization]: we may assume that the contradictory diacritics block the rule. The prediction of this approach is that when both halves of the geminate structure meet the structural description of the rule no blockage effect will be observed. The relevant structure has been located by Schein in a Tigrinya form like mäsäkärä 'witness-frequentative'. Schein suggests that frequentatives have a doubly attached penultimate root consonant, thus the frequentative

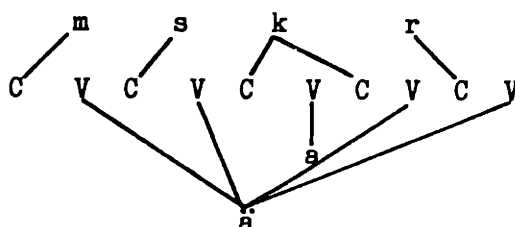

corresponds to the zero-form

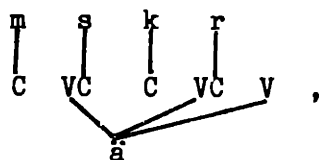

mäsäkärä, from which it has been created by the insertion of a VCV unit.



The velar of mäsäkärä is therefore a geminate of the type given in (21), yet Spirantization applies to both of its halves. This is so because both Cs associated with the velar have been marked [+Spirantization] since they both follow Vs<10>.

It seems possible then to derive one half of the effects of (16'), the prohibition on changing the identity of a geminate cluster member, from an extension of already existing conventions on rule application. To explain the failure of epenthesis to split a true geminate cluster I will adopt a suggestion attributed in Halle and Vergnaud (1982) to Jonathan Kaye: "if a V slot is inserted between the two C-slots in order to syllabify the sequence, the V slot cannot be linked to a schwa on the melody tier without violating the crossing prohibition, as illustrated in (4.e):

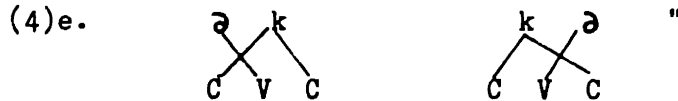

The proposal implicit in this observation is to assume that a segment inserted by a phonological rule like epenthesis is assigned to the main melodic core, in contrast to affixal segmental material which generally occupies separate tiers, as in the representation in (1), repeated below, where a is a distinct morpheme from ktb:

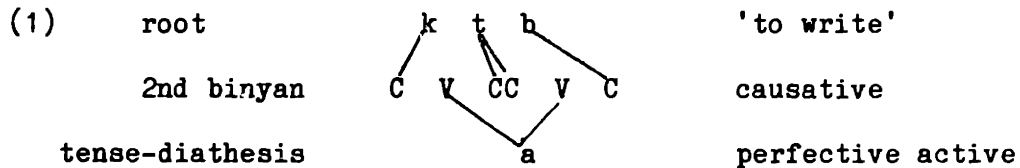

We have seen so far that the bulk of the cases covered by the AIC follow from two distinct principles of grammar:

- (22) a. Segments which meet the structural description of a rule n are marked [+rule n]; segments which do not are marked [-rule n]; rule n applies only to segments marked [+rule n].
- b. Segmental material inserted by phonological rules is assigned to the melodic core.

The provisions in (22) make partly different predictions from the AIC: (22.b) predicts that a vocalic infix will be able to split a true geminate cluster even though an epenthetic vowel may not. AIC, on the other hand, cannot distinguish between epenthesis and a morphological infixation process: neither rule may affect the adjacency of the geminate cluster. The following example from Saib 1976 shows that (22.b) is the correct constraint. The Ntifa and Zayan dialects of Tamazight Berber form intensive verbs by prefixing it- to the verbal root and by inserting a before the last radical consonant. Formally, the intensive verb template described by Saib is

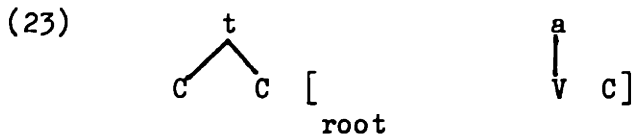

Saib exemplifies intensive formation in its general form with the intensive of

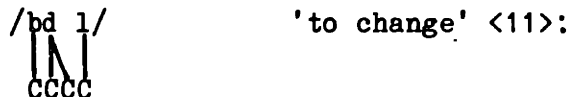

ettbeddal, where e stands for epenthetic schwa and a is the intensive infix. When the last radical segment is a geminate, the infixation mandated by (23) applies as in ettbeddal and we obtain the

split geminates in (24):

(24)	Zero Form	Intensive Form	
	/fz / [fezz]	[ettefzaz]	'to chew
	$\begin{array}{c} \text{fz} \\ \quad \diagdown \\ \text{ccc} \end{array}$		
	/gz / [gezz]	[ettegzaz]	'to gnaw'
	$\begin{array}{c} \text{gz} \\ \quad \diagdown \\ \text{ccc} \end{array}$		
	/pd / [bedd]	[ettebdad]	'to stand up'
	$\begin{array}{c} \text{pd} \\ \quad \diagdown \\ \text{ccc} \end{array}$		

The full autosegmental representation ettefzaz can be inspected in (25):

(25)	intensive melody	$\begin{array}{c} t \quad a \\ \diagdown \quad \diagup \\ \text{CC} \quad \text{CCVC} \\ \quad \quad \quad \\ \text{fz} \end{array}$	(surface $\begin{array}{c} t \quad a \\ \diagdown \quad \diagup \\ \text{YCCYCCVC} \\ \quad \quad \quad \\ \text{e} \quad \text{eiz} \end{array}$)
	skeleton		
	melodic core (root melody and epenthetic schwas)		

The infixation of a in the intensive form stands in contrast with epenthesis, a phonological rule, which may not break a geminate cluster: epenthesis normally inserts a schwa before a consonant that could not fit into the CVC syllable template of Berber^{<12>} (as in exdem 'to work' from /x^hdm/) but leaves internal triconsonantal clusters intact if they contain a geminate (annli 'brain', θigglitt 'echo') as well as final geminate clusters (cf. θigglitt, fezz, etc.). While (22.b) predicts correctly that the epenthetic schwa cannot break a true geminate cluster but that the affixal a of the

intensive could, Guerssel's AIC will also rule out the split geminates created by the intensive rule.

Another difference in coverage between the AIC and the principles listed in (22) concerns (22.a). This principle, when embedded in an autosegmental framework, cannot prevent certain rule applications whose linearized outputs look like violations of the AIC. Consider the fact that geminate stops in Attic Greek can be either unaspirated, as in pappos 'grandfather', or half aspirated, as in Sapp^hσ: as we shall see in Chapter 3, there are no fully aspirated geminates in Attic like p^hp^h and there are no half aspirated geminates like p^hp. This pattern seems to demand a rule which deaspirates the first member of a geminate stop cluster. The problem raised by such a rule is that a linear statement of it will violate the AIC: only one member of the geminate cluster will be segmentally affected. An autosegmental solution to this problem will take the following form: the feature of aspiration will be shown to occupy in Greek a distinct tier from the melodic core (Chapter 2, section 4.3; Chapter 3, section 5.5.2). If, moreover, we assume that aspiration is linked directly to the skeleton slots, we obtain intermediate representations like (26):

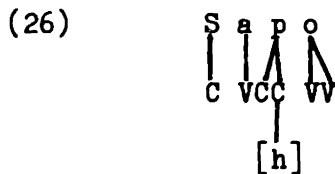

Deaspiration can now be formulated as in (27):

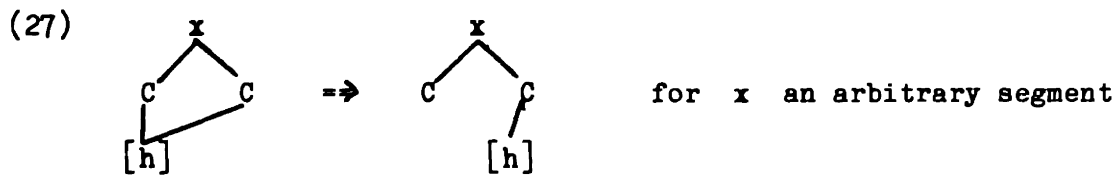

(22.a) will not block the application of such a rule to the first member of a geminate cluster and consequently

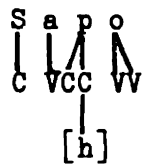

will be generated, corresponding to linear Sapp^ho.

Let us summarize the results of this section as we will have occasion to refer to them later in the chapter. The first objective of this discussion of geminate behavior was to justify the autosegmental representations in (14) and (15), repeated below,



which express a difference in structure that cannot be translated into a linear framework. We have shown, following Schein 1981, that the principles governing geminate behavior, as encoded in (16'), hold of tautomorphic geminates and of heteromorphic clusters that underwent a gemination rule, but not of heteromorphic identical segments: we decided that the most natural representation for the latter type of sequences was (15). By elimination, (14) was

arrived at as the structure of the geminate clusters to which (16') applies. We then set out to derive (16') from the structure of true geminates: two principles were proposed, (22.a) and (22.b), whose application to structures like (14) yielded most of the facts which the original constraint, Guerssel's AIC, had been designed to cover. Facts on which the AIC and (22) make divergent predictions were then shown to support (22).

An important consequence of abandoning both the AIC and (16') is that we may now explore the effect of the abstract configurations in (14) on phonological rules without having to limit ourselves to geminates in the strict sense: if Halle and Vergnaud's suggestion is correct that some segmental assimilation rules are autosegmental operations, it is possible that configurations like (28) arise through the application of assimilation rules:

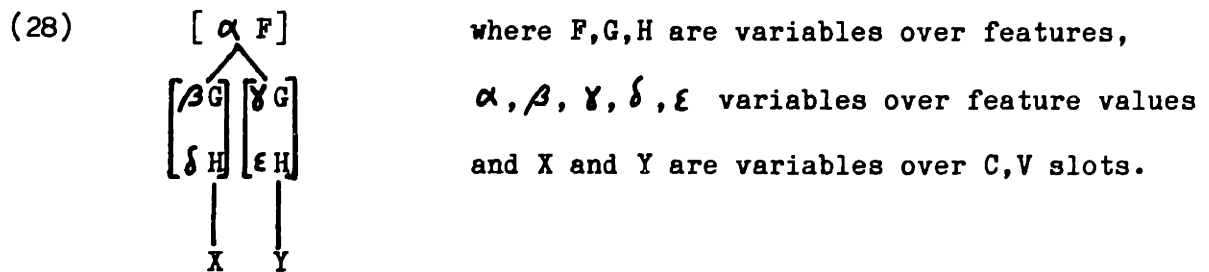

Our analysis of geminate structures makes it possible now to test whether partially assimilated clusters have the structure of (28): if they do, some of the constraints on geminate behavior should also apply to them. We take up this question below.

1.3 Linked matrices

1.3.1 The autosegmental theory of assimilation rules

This section develops the suggestion made by Halle and Vergnaud (1980) that rules of assimilation in point of articulation be stated autosegmentally, as shown in (29):

(29) a. Structural Description

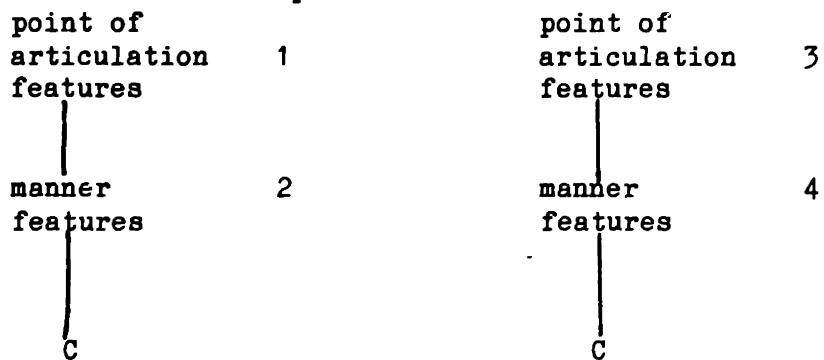

b. Structural Change:



I will propose that all (local) assimilation rules involve changes in the association between the melodic core and the skeleton of the type shown in (29). I will also suggest that phonological gemination rules, rules which turn a cluster into a geminate sequence, are frequently partial assimilation rules, whose immediate output, formally identical to that of (29), contains two columns of identical feature specifications:

(30)

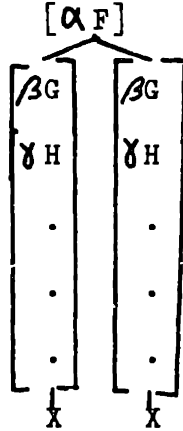

The framework developed here for the statement of assimilation rules will find its applications to the theory of syllabification in Chapter 3.

Halle and Vergnaud put forth (29) for one implied reason: assimilations in point of articulation involve changes in all the features specifying point of articulation (coronal, lateral, anterior, high, back...). A linear statement of such rules, which must list each and every feature changed, cannot explain why it is that only a certain subset of the features is consistently affected: within a linear framework, a rule which changes some place and some manner features is just as highly valued as a rule which affects the same number of features, all of each specify place alone. An autosegmental framework for assimilation, coupled with the assumption of major constituents within the segmental matrix (like place features and manner features) can successfully distinguish between a natural rule like assimilation in point of articulation between a nasal and a following stop, and an unnatural one, like a rule which assimilates the same cluster in voice and height only.

The rationale for introducing autosegmental assimilation rules does not however dictate the particular formalization that Halle and Vergnaud adopted: at first sight it seems equally possible to assume that each one of the major components of a distinctive feature matrix corresponds to a separate tier, independently linked to the skeleton. Such multidimensional representations are shown, in simplified form, below:

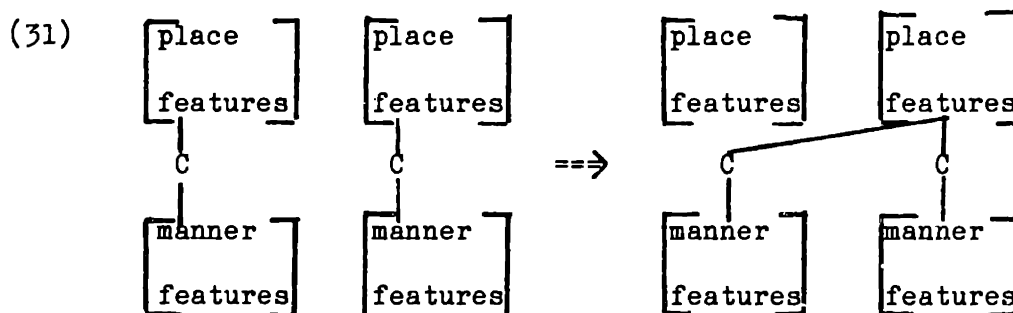

The theory from which representations like (31) follow amounts to the claim that there is no single constituent corresponding to the notion of segmental matrix and no single tier of representation corresponding to what we have called the melodic core. Accordingly, I will refer to it as the Independent Linking Hypothesis, in contrast with the Melodic Tier Hypothesis, which dictates structures like (29) and (30). I should make it clear now that very little evidence relevant to the choice between these will be introduced in this study. Chapter 3 will provide one instance in which a feature, aspiration, will have to be represented as occupying a different tier from other components of the segmental matrix as shown in (26) above. On the other hand, we will also see that it is useful to distinguish between the autosegmentalized aspiration of certain sounds

and the non-autosegmentalized aspiration of others: this distinction is available within the framework of the Melodic Tier

Hypothesis as the distinction between a structure in which aspiration is linked directly to the skeleton and, thus, defines its own tier, independently of the melodic core, and a structure in which the aspiration specifications are part of the segmental matrix, a unit in the melodic core:

(32) a. Autosegmentalized aspiration

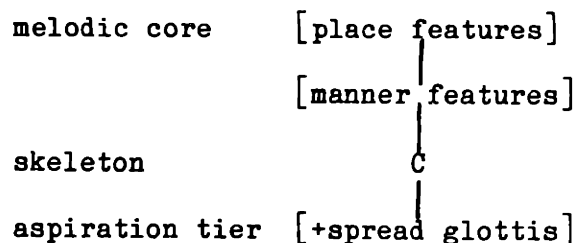

b. Non-autosegmentalized aspiration

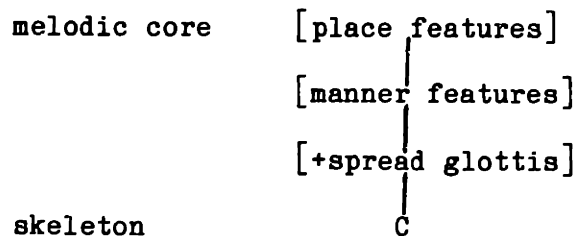

Since it is difficult to imagine how this distinction could be represented in a framework like that of the Independent Linking Hypothesis, whose defining property is that all features are autosegmentalized, I will adopt here the Melodic Core Hypothesis. Needless to say, the choice between these theories awaits further research.

Let us begin by introducing the necessary terminology: I will refer to structures like (33.a) and (33.b) as being segmentally linked, by which I mean that the adjacent skeleton slots share a subpart of their associated matrices; the name identifying such structures will be linked matrices, which distinguishes them from unlinked matrices, shown schematically in (34) below, as well as from merged matrices, shown in (35), a technical term for true geminates, introduced to bring out the formal similarity between the output of partial and total assimilation rules.

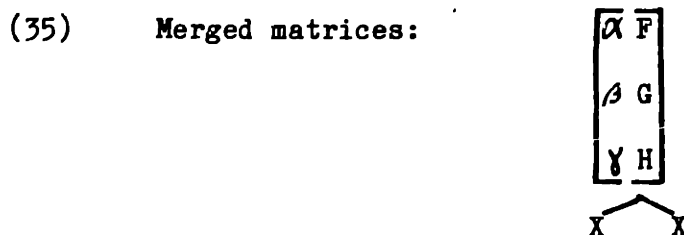
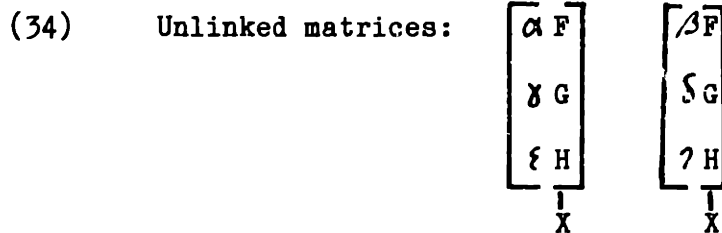
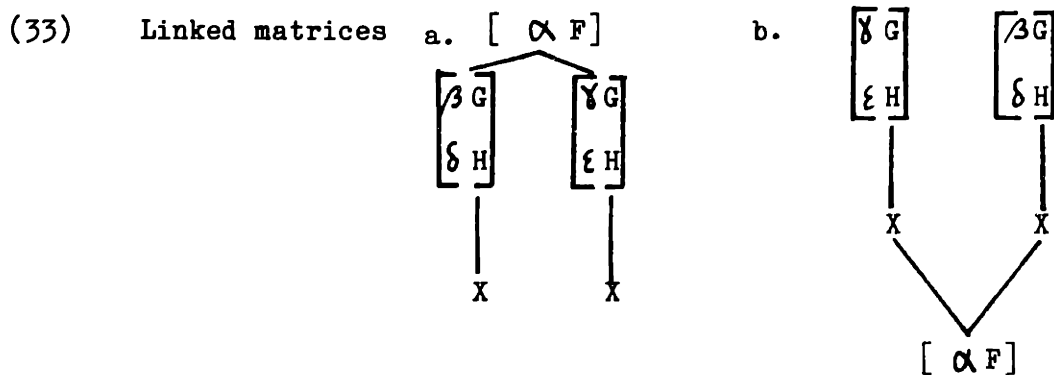

1.3.2 Geminate in the output of partial assimilation rules

The first argument in favor of the autosegmental format for partial assimilation rules emerges as we reconsider one aspect of the typology of geminates drawn by Guerssel (1978): recall that the initial problem faced by the Adjacency-Identity Condition (AIC, (16) above) was that heteromorphemic sequences of identical segments which had not undergone an assimilation rule appeared to violate AIC's provisions. Such sequences became subject to the AIC only once an assimilation rule applied. To explain this fact we assumed that all cases discussed by Guerssel involved gemination rather than assimilation rules. Thus, we assumed that the coronal cluster voicing assimilation which applies in Algerian and Moroccan Arabic should be stated as in (36), rather than as in (37):

(36) Arabic Coronal Cluster Assimilation: a gemination rule

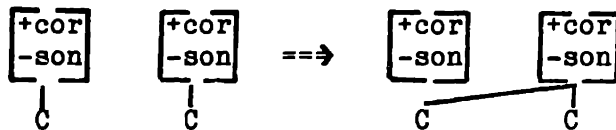

(37) Arabic Coronal Cluster Assimilation: a voicing assimilation rule.

$$[+cor, -son] \implies [\alpha \text{ voice}] / \text{ ______ } [+cor, -son, \alpha \text{ voice}]$$

It was necessary to adopt (36) over (37) in order to obtain the structures which identify true geminates. But in making that decision we did not consider the possibility of stating (37) autosegmentally, as in (38):

(38) Arabic Coronal Cluster Assimilation: an autosegmental voicing assimilation rule.

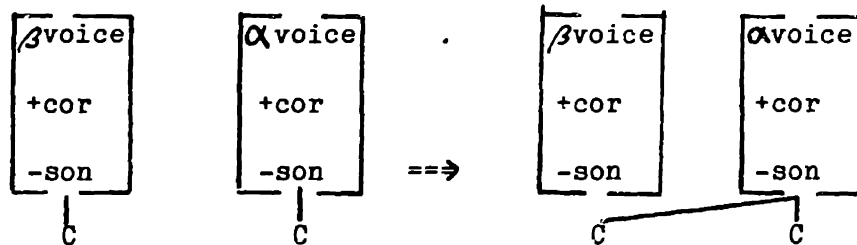

The output of (38) is a pair of linked matrices whose unshared portions contain identical specifications for all features. Let us assume that when such structures are created, a convention, stated below in (39), percolates up all features with identical specifications:

(39) The Shared Features Convention

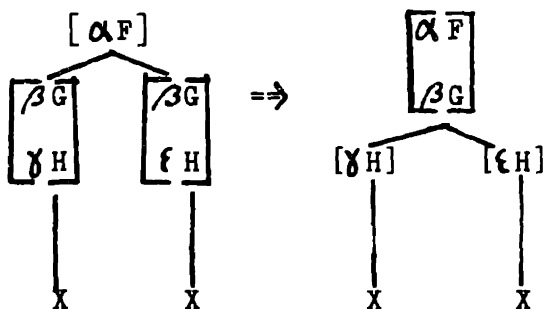

The need for (39) will be discussed more fully below, in section 1.3.4.

The joint effect of rule (38) and of The Shared Features Convention in (39) is to create true geminates in the output of a partial assimilation rule. While the facts of Arabic as described by Guerssel, are neutral between the alternatives listed above, cases like the following require that geminate clusters be derived from

underlying distinct consonants by partial assimilation rules formulated autosegmentally. Our task is to establish two points: first, that the outputs of the assimilation rule discussed includes true geminates; second, that the rule must be stated as a partial assimilation.

Saib (1976) notes that many of the geminate clusters of Berber originate as heteromorphemic sequences of distinct consonants: for example the diminutives of abud 'knee' and abuḍ 'bottom' are /t-abud-t/ => [tafutt], and /t-abuḍ-t/ => [tabuṭṭ] respectively; the phrase 'Berber man and Berber woman' becomes, from underlying amazig d θ-amazig-θ, surface [amazigetmazigθ]. Let us consider this phrase in some detail, since examples like it indicate that the output of the rule assimilating d θ to tt<14> is a true geminate: Saib introduces [amazigetmazigθ] as an illustration of the phonology of the Berber Construct State: a noun in the Construct State undergoes syncope of its first vowel, thus underlying θamazigθ becomes θmazigθ. The result of syncope is an input to the rule of epenthesis discussed above (page 38), which would, in the general case, insert a vowel before any consonant that found itself outside the Berber CVC syllabic template. Thus n θ-amazig-θ 'of the Berber woman', a phrase which also requires the Construct State, becomes, through syncope and epenthesis, [neθmazigθ]: epenthesis breaks the intermediate cluster nθm by inserting schwa before the second consonant.<15> Recall now that epenthesis does not split true geminate sequences, in Berber as elsewhere: this observation can explain why the surface form corresponding to amazig d θ-amazig-θ is [amazigetmazigθ] rather than *[amazigetmazigθ]. The required derivation

is seen in (40):

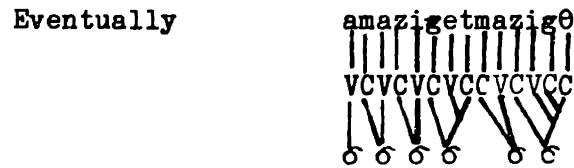

The crucial aspects of the derivation in (40) are: (a) the fact that the assimilation rule creates a geminate structure

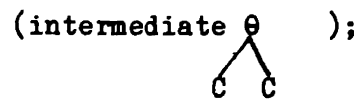

and (b) the fact that epenthesis inserts the schwa not before the first unsyllabified C counting from the right, as it usually does,

but before the second

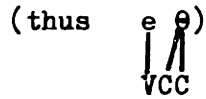

so that the geminate cluster will not be split. If the assimilation of d to θ in [amazigetmazigθ] had not created a true geminate, the location of the epenthetic vowel could not be explained.

We now need to show that the assimilation rule involved in (40) is a partial assimilation rule: this can be gathered from the fact that all coronal clusters whose first member is not a strident agree in voice. Thus, beside examples like /t-abud-t/ => [tafutt], /qqed-θ/ => [eqqett] 'burn it', /sfed-θ/ => [esfett] 'wipe it', Saib cites partially assimilated forms like /θ-zil/ => [edzil] 'she is good' and /i-qqed-s/ => [iqqets] 'he burned you'. In view of such forms the voicing assimilation rule of Berber must be stated as in (41):

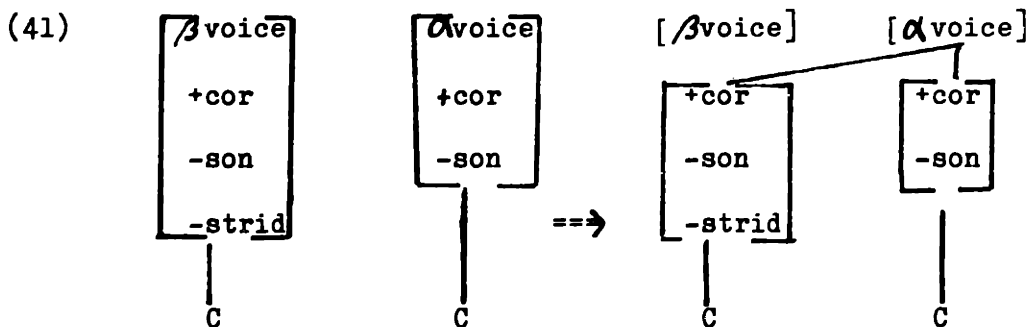

(41) will yield linked matrices like (42.a) and linked matrices like (42.b), which can be subjected to the Shared Features Convention and become merged matrices, i.e. true geminates:

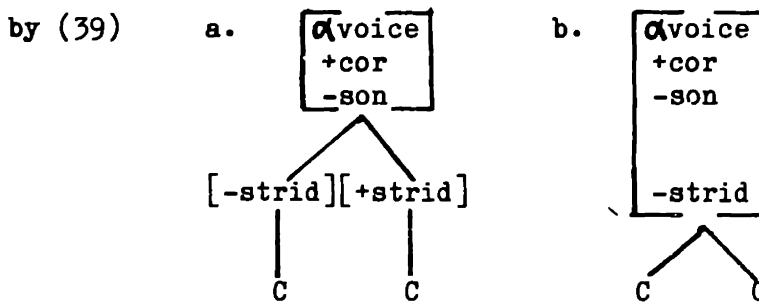
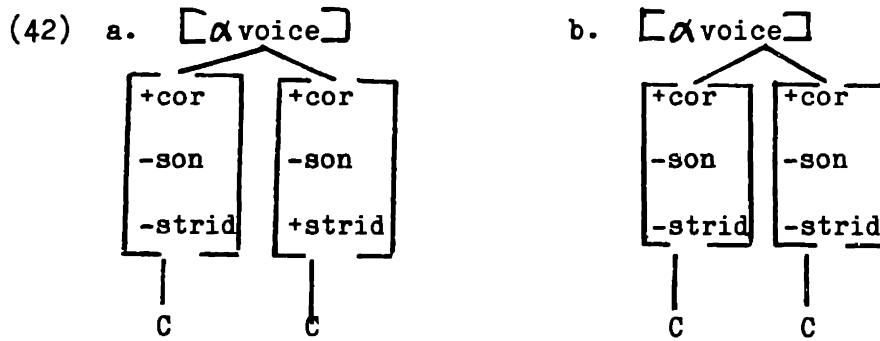

A partial assimilation rule stated linearly, like (37), will not explain why some of the outputs of the rule have the behavior of true geminates; a direct gemination rule like (36) will not succeed in unifying what are clearly instances of the same process: the voicing assimilation in [iqqets] and the one in [tafutt]. By this process of elimination we arrive at the conclusion that the partial assimilation rule stated autosegmentally in (41) is unavoidable¹⁸.

1.3.3 Partially assimilated clusters and constraints on geminates.

I turn now to a different type of argument in favor of formulating partial assimilation rules autosegmentally: I will consider the behavior of partially assimilated clusters with respect to rules that can test for the existence of segmental linking. Such rules

include epenthesis, since segmentally linked sequences of the type shown in (43) should block it in the same way geminates do:

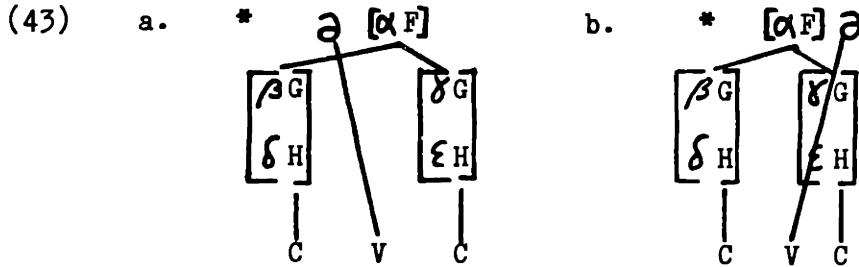

Segmental rules can also be used to test segmental linking: the shared portion of the segmental matrices in structures like (44b) should not be affected by any segmental rule whose structural description is met by only one of the two segments. Thus, suppose that rule n changes the specifications [$+F$] of any segment in post-vocalic position to [$-F$]; suppose also that there exist in the language in question consonant clusters linked with respect to [$+F$]. By convention (22.a) the Shared feature [$+F$] of such clusters will receive the contradictory markings [$+rule\ n$] and [$-rule\ n$], corresponding to the fact that one of the C slots [$+F$] is indirectly linked to satisfies rule n, while the other one does not. As a result, rule n should fail to apply to such linked matrices, exactly as it would fail to apply to a geminate structure.

(44) a. Rule n

[+F] ==> [-F] / V ____

b. Linked clusters with respect to [+F]

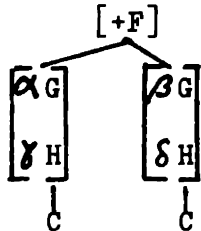

c. Marking the applicability of rule n on linked clusters

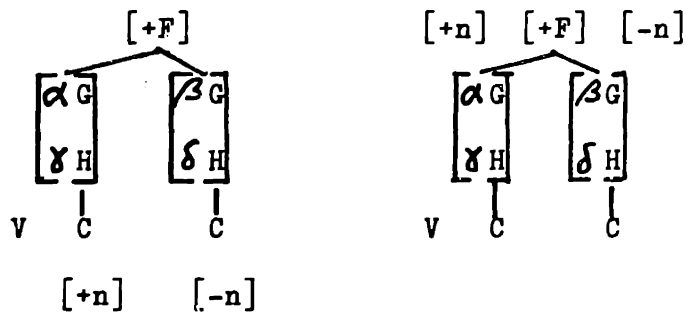

I begin by showing that epenthesis fails to apply in Kolami, a Dravidian language, when its result would be to split a geminate cluster or a partially assimilated cluster. In what follows I rely to some extent on Kenstowicz's and Pyle's (1973) analysis of the Kolami epenthesis and assimilation rules.

Kenstowicz and Pyle presented Kolami as one of the languages in which epenthesis could not split a geminate cluster. The key element in their argument was a vowel copy rule which breaks up a root final cluster of two consonants if it occurs word finally or if the next morpheme begins with a consonant:

(45) Vowel Copy (from Kenstowicz and Pyle 1973)

V C C	{	#	}	Note: V and C stand here for
		C		
	==>			
	1 2 3	4	1 2 3 4	the relevant skeleton slots and
				their associated segments.

I will adopt this statement of the rule unchanged, sidestepping the obvious problem posed by the disjunction $\left\{ \begin{matrix} \# \\ C \end{matrix} \right\}$: nothing hinges on the formulation in (45). Vowel Copy applies in forms like the ones in the first two columns of (46):

(46)	Imperative	Past	Present	
/melp/	melep	melep-tan	melp-atun	'shake'
/ayk/	ayak	ayak-tan	ayk-atun	'sweep'
/katk/	katak	katak-tan	katk-atun	'strike down'

When the verb stem ends in a geminate cluster Vowel Copy does not apply: rather, the preconsonantal or word final geminate appears degeminated on the surface, as shown in (47):

(47)	Imperative	Past	Present	
/idd/	iḍ	iṭtan<19>	idḍ-atun	'tell'<20>
/add/	aḍ	aṭtan	adḍ-atun	'thirst for'

Since the conclusion that geminate clusters cannot be split by rules of vowel insertion has by now received considerable support, I will not review in any more detail this aspect of the Kolami facts. I will concentrate instead on the more significant failure of Vowel

Copy to apply to homorganic nasal-stop clusters. This fact is illustrated in (48):

(48)	Imperative	Past	Gerund	Present	
/pong/	poŋ	poŋk-tan	poŋk-tna	poŋg-atun	'boil over'
/da:ŋ/	da:ŋ	da:ŋk-tan	da:ŋk-tna	da:ŋg-atun	'hide'
/mind/	mind	mintan<19>	mi:na:19>	mind-atun	'bury'

If Vowel Copy had been applicable to forms like the imperative mind or the past tense poŋk-tan, we would have obtained *minid, *poŋok-tan.

How significant is this fact? Can we deal with it by adding a condition on the rule of Vowel Copy which requires the first member in the consonant cluster to be a non-nasal? The answer comes from the observation that the homorganic nasal-stop clusters are created by a rule which is restricted to apply before voiced stops alone: sequences of nasal-voiceless stop are not necessarily homorganic, while nasal-voiced stop clusters invariably are<21>. Consider now verb roots ending in a nasal-voiceless stop sequence:

(49)	Imperative	Past	Gerund	Present	
/kink/	kinik	kinik-tan	kinik-tna	kink-atun	'break'
/pank/	panak	panak-tan	panak-tna	pank-atun	'send'

The forms in (49) differ in two respects from the ones in (48): the root final cluster is not homorganic and Vowel Copy is seen to apply as it does in (46). I suggest that the solution to our problem is to write the rule of nasal-stop assimilation autosegmentally, and to

let its outputs block Vowel Copy by the same mechanism geminate clusters do:

(50) Nasal Assimilation

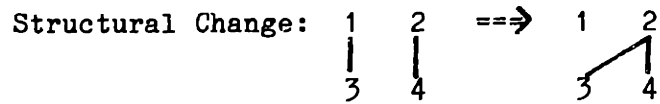
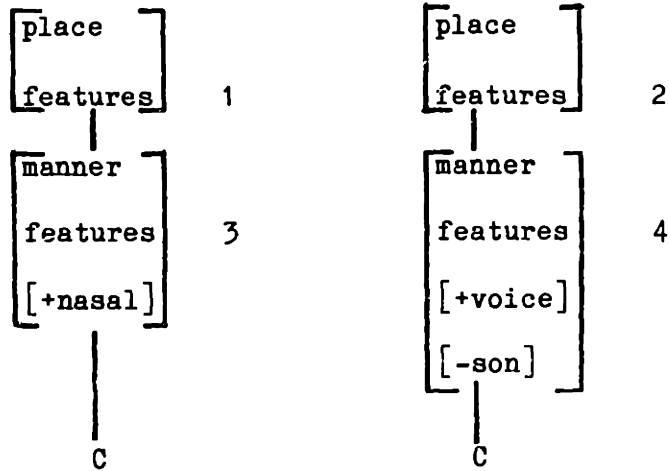

The root /pong/, to which (50) is applicable, acquires in its output a segmentally linked final cluster:

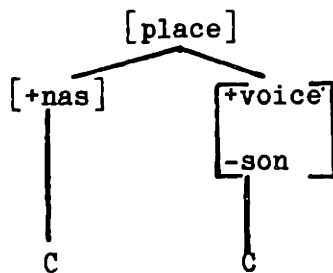

In contrast, the root /pank/, to which (50) cannot apply, ends in a pair of unlinked matrices,



which cannot block Vowel Copy.

The only alternative I can see to this analysis of Nasal Assimilation involves restating Vowel Copy as in (51):

(51) Vowel Copy: revised

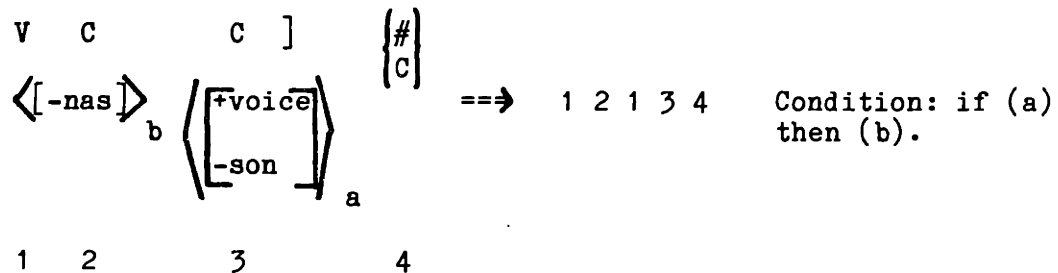

However, the formulation in (51) is simply a roundabout way of saying that Vowel Copy does not apply if Nasal Assimilation does: it is inconceivable that the facts of Vowel Copy would be the same in a language in which Nasal Assimilation did not exist as a rule or was not subject to the restriction it is subject to in Kolami. I conclude that (50) must be retained as the formulation of Nasal Assimilation.

Recall now that we raised above (page 44) the possibility that segmental matrices might consist of separate constituents, like place and manner features, each of which is independently linked to the skeleton. I referred to this hypothesis as the Independent Linking Hypothesis, in contrast to the Melodic Core Hypothesis, adopted here. I will show now that either alternative accounts for the fact that Vowel Copy cannot split a segmentally linked cluster. The representations given by each hypothesis to the homorganic nasal-stop clusters of Kolami are given in (52.a) and (52.b). In both cases I represent the ill-formed output of Vowel Copy:

(52) The output of Vowel Copy as applied to an assimilated cluster

a. Independent Linking Hypothesis

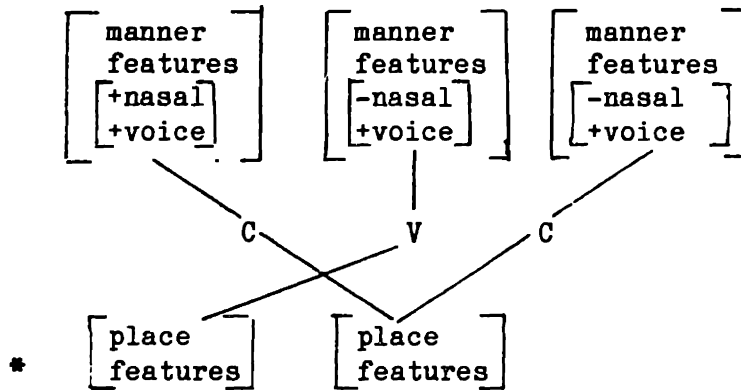

b. Melodic Core Hypothesis

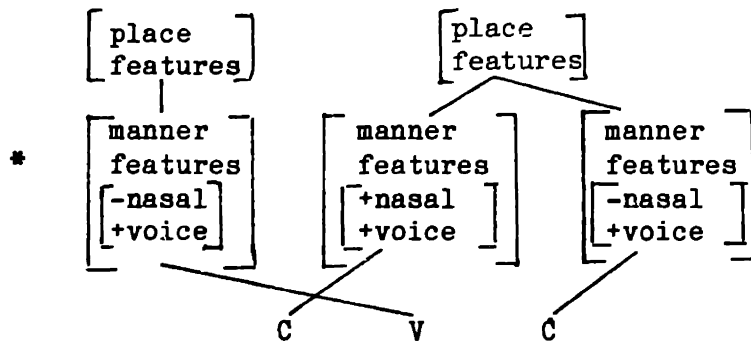

In both cases the segmental link established by the rule of Nasal Assimilation intersects the association line between the V slot and the vocalic segment introduced by Vowel Copy.

We have seen so far that partially assimilated clusters have in common with true geminates the property of blocking vowel insertion rules, a fact we explained by assuming that assimilation rules create segmental linking. I now turn to the other property which, according to the same hypothesis, true geminates should share with partially assimilated sequences: as already noticed above any unit

in the melodic core which is shared between several skeleton positions should be inaccessible to rules whose structural descriptions are met by only one of the linked matrices. If we can show this to be the case with partially assimilated clusters, we will have established in yet another way the necessity to state assimilation rules autosegmentally. In other words, our task is to document the type of situation represented schematically in (44): a segmental rule which fails to affect one half of a partially assimilated cluster, in the same way in which Spirantization in Tigrinya, Berber or Biblical Hebrew fails to affect the first half of a true geminate sequence.

The case I will discuss here involves the rule of Sanskrit which turns a word final s into h (visarga). Following Whitney (1889: paragraph 67), I assume visarga to have been a feature of aspiration associated with the preceding vowel, "a final h-sound (...) uttered in the articulating position of the preceding vowel" (Whitney, loc.cit.). From this description of the phonetics of visarga I infer that the rule of s \Rightarrow h should be characterized as the process in (53), whereby h acquires the place of articulation features of the preceding vowel:

(53) The Visarga rule

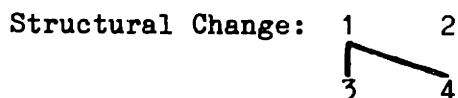
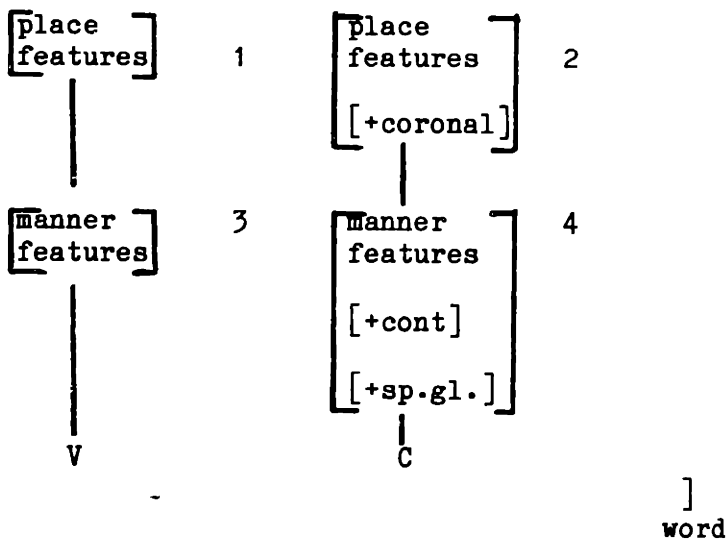

I state (53) as an autosegmental rule, for the sake of uniformity. Its formulation is not, however, at issue here and a linear statement of the changes stipulated by (53) will do as well for the purposes of this argument.

The Visarga rule applies only after two sandhi rules of assimilation in place of articulation: the first assimilates obligatorily any coronal to the initial coronal stop of a following word; the second, an optional rule, assimilates a final g, to any following obstruent. I give a preliminary linear formulation of the rules in (54) and some illustrative examples in (55):

(54) a. Assimilation to Coronal Stop (obligatory)

[+cor] ==> [α place] / ___ [α place, +cor, -cont, -son]
phrasal level

b. Assimilation to Obstruent (optional)

[+cor, +cont] ==> [α place] / ___ [α place, -son]
phrasal level

(55) a. Assimilation to Coronal Stop: examples

tat 'that' cakṣus 'eye' ==> tac cakṣuḥ

cakṣus 'eye' tat 'that' ==> cakṣus tat

tatas 'thence' ca 'and' ==> tataś ca

pādas 'the foot' ṭalati 'is confused' ==> pādaṣ ṭalati

<c> notes a palatal affricate, <ś> notes the corresponding
continuant; <ṭ> and <ṣ> note the retroflex stop and
continuant.)

b. Assimilation to Obstruent: examples

manus 'the man' svayam 'self' ==> manus svayam or
manuḥ svayam

Indras śūras 'the hero' ==> Indraś śūraḥ or Indraḥ śūraḥ

tās 'those-fem.' ṣaṭ 'six' ==> tāṣ ṣaṭ or tāḥ ṣaṭ

divas 'of a god' putras 'son' ==> divaḥ putraḥ or
divaḥ putraḥ<23>

Nalas kāmam 'at will' ==> Nalaḥ kāmam or Nalaḥ kāmam<23>

Let us first establish the order of these three rules: from the

variation illustrated in (55.b) we can tell that the most general assimilation rule, (54.b), precedes (53). Since (54.b) is optional, both its output and the output of the obligatory (53) surface in the environments where (54.b) is met. Had (53) preceded (54.b), only visarga would surface and (54.b) would never be applicable. We can also tell that (54.a) must precede (53): otherwise tataś ca, pādaṣ ṭālati would never be produced and only incorrect forms ending in visarga would surface. The problem, however, is that if the visarga rule follows (54.a) and (54.b) it is difficult to explain why phrases like cakṣus tad don't surface as *cakṣuḥ tad: the visarga rule seems applicable in these cases. In fact, the failure of (53) to apply before a coronal stop is, as Kiparsky (1973) observes, the only impediment in recognizing the relation between (54.a), (54.b) and (53) as an ordinary case of disjunctive order, with (53) as the elsewhere case.

An autosegmental view of partial assimilation rules can solve this problem: both (54.a) and (54.b) create clusters which share the place of articulation features of the second member. (53), whose structural description is met by only the first matrix in a linked cluster, will be unable to erase the shared place features component.

(56) a. Assimilation to Coronal Stop: an autosegmental statement

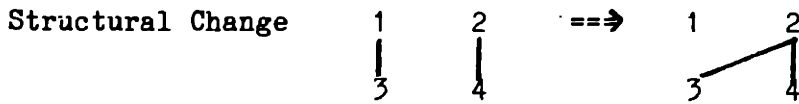
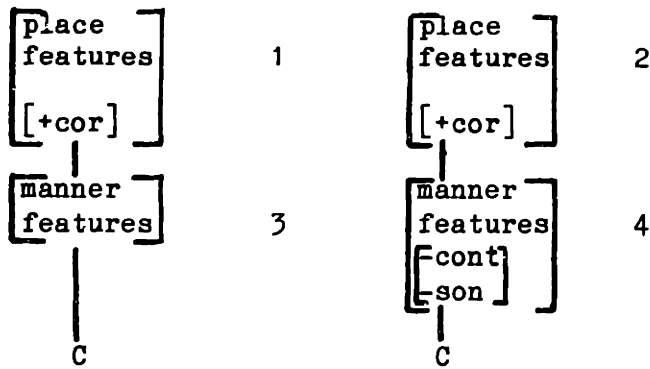

b. Assimilation to Obstruent: an autosegmental statement

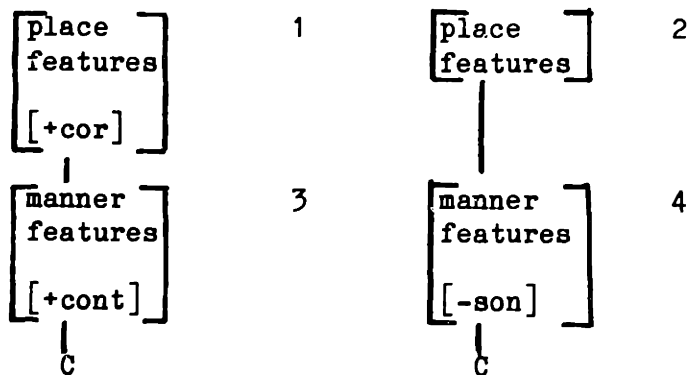

Structural Change: as above.

The representation of the relevant portion of any phrase which, like cakşus tad, had undergone (56.a) will be as in (57):

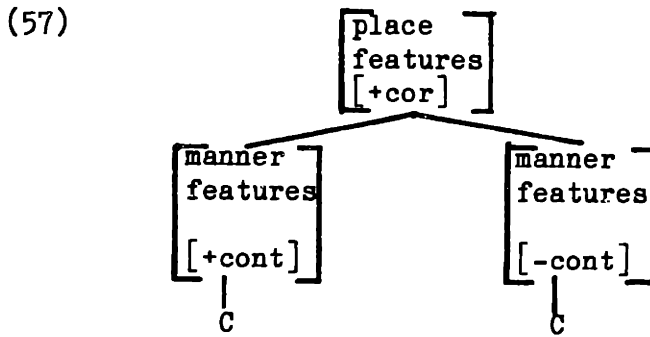

The place features component will now be immune from any rule whose structural description is not met by both of the matrices sharing it. Thus, even though a linear representation of the sounds makes the final s in caḁṣus tad look like an eligible target for (53), we understand now why it is not.

The interaction between the Sanskrit visarga rule and the assimilations in place of articulation documents the situation anticipated in (44) : a shared feature cannot be affected by a rule whose structural description is met by only one of the matrices sharing it. This fact finds an explanation in the autosegmental representation of partially assimilated clusters.

I will conclude this section by pointing to a prediction of the ideas presented here that I was unable to verify properly but which strikes me as very likely to be correct.

A primary source for derived geminate clusters are rules like the Moroccan Coronal Cluster Assimilation (cf. (19) above), the Proto-Italian rule responsible for correspondences like Lat. factum: Ital. fatto, the Greek nasal assimilation which turns for instance /op-mat/ into omma. Such gemination rules typically apply to

consonant sequences that already have a large number of identical feature specifications. Conversely, I have not yet encountered gemination rules whose input are just maximally different sequences like pr, kl, ty. This fact can be explained if the main and maybe the only source of derived geminates are partial assimilation rules that happen to apply to clusters differentiated only by the feature(s) undergoing assimilation. So far, this explanation is available within a linear as well as an autosegmental framework. However, the format of assimilation rules presented here further predicts that all such derived geminate clusters will be true geminates, rather than adjacent identical segments (unlinked matrices, as in (34)): they have become geminates by undergoing an assimilation rule, which, in this format, is a rule which establishes a segmental link between two matrices and allows the Shared Features Convention to turn the output of assimilation into a true geminate structure. Note moreover that an autosegmental framework which recognizes the distinction between skeleton and melodic core but does not allow partial assimilation rules to be stated as autosegmental operations cannot make this prediction: in such a framework, the only means whereby an input sequence of unlike consonants can be turned into a true geminate structure is by disassociating one of the C slots entirely from its associated segmental matrix and by reassociating it to a neighboring matrix:

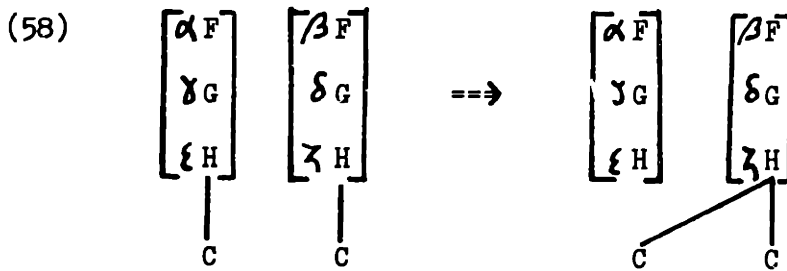

But if this is the only possible origin for true geminates we lose the explanation for why gemination rules apply most frequently to clusters differentiated by only one or two specifications.

I must leave it to a future typology of geminate clusters to determine whether derived geminates of the type mentioned are merged matrices or unlinked matrices. From the cases known to me (rule (19) and the Tigrinya assimilations discussed by Schein (1981) -- cf. footnote 18), it seems likely that the former conclusion will systematically turn out to be the correct one.

1.3.4 The need for a Shared Features Convention

One result of the preceding discussion is that geminates and partially assimilated clusters are subject to identical constraints: they cannot be split by epenthesis and their shared features cannot be affected by rules met in only half of the linked structure. This being so, one may ask why we need at all the Shared Features Convention, introduced in (39) and repeated below:

(39) The Shared Features Convention

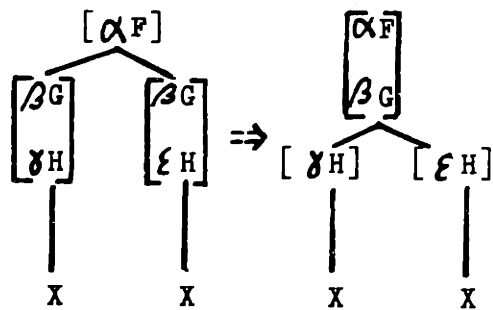

The input to (39) will be sufficient to block epenthesis and will fail to undergo any rule affecting the shared feature $[\alpha F]$ unless the rule is met by both members of the cluster.

The reason why the Shared Features Convention will probably have to be maintained -- although no real examples supporting it come to mind -- is that it spares us some odd predictions. To see this, suppose that (39) doesn't function in a language in which there are underlying true geminates as well as clusters resulting from partial assimilation rules; suppose also that this language is similar to Tigrinya in that it has a rule of Spirantization that applies to any postvocalic stop. The absence of (39) will predict the following range of facts: underlying true geminates will fail to undergo Spirantization since by definition all their features, including $[\alpha \text{continuant}]$, are shared between the two C slots. Clusters resulting from partial assimilation rules will behave as follows: if there is a rule of continuancy assimilation, the clusters resulting from it, whether geminates or not, will fail to undergo Spirantization, since $[\alpha \text{continuant}]$ will be the shared feature of the linked clusters. But the clusters resulting from any other par-

tial assimilation rule, even if they look like geminates, will be able to undergo Spirantization since their structures will be as in (59):

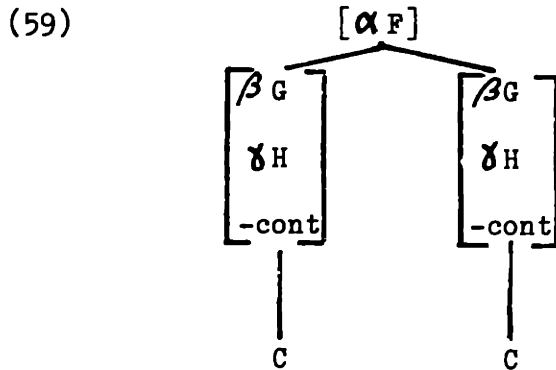

Because (39) has not percolated up the identical features, the continuancy specifications of the linked matrices are not shared and therefore can be affected by any rule met in only part of the cluster.

It is quite likely that Tigrinya is an actual, rather than a hypothetical test case for this idea: as Schein (1981) notes, some of the derived geminates of Tigrinya, all of which fail -- like underlying geminates -- to undergo Spirantization, probably result from rules of glottal assimilation and assimilation in place of articulation. If so, the necessity of (39) is established: without it we cannot explain why a rule which creates in its immediate output clusters sharing the feature [-glottal] or [+high] also prevents any future application of a rule changing continuancy specifications.

2. Melody--skeleton--syllable mapping

I have assumed from the outset the existence of a tier mediating between syllabic organization and segmental content.

There are however recent approaches to syllable structure in which this tier, the skeleton, plays no role.

Selkirk (1982), who argues for the elimination of the skeleton along with all reference to major category features, mentions some of the consequences of this move. She notes that languages which recognize underlying consonant and vowel length distinctions must differentiate between the lexical representations of words like (hypothetical) kapa and kappa. She agrees that the distinction is not segmental but structural and proposes to represent it as an underlying distinction in syllable structure between

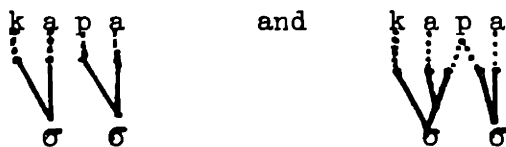

This is the only option for the representation of geminates - or of any underlying length distinction - in the absence of a skeleton tier.

By noting this consequence of eliminating the skeleton, Selkirk has in fact uncovered the major argument in favor of maintaining it : it has been demonstrated by Harris (1982) that syllable structure is not a lexical property but a property assigned by cyclic rules .

Harris shows that segmental feature-changing rules apply in Spanish on

the first cycle when they are syllable dependent. Had syllabification been lexical, such rule application would violate the strict cycle. However, if syllable structure is assigned as part of the phonological derivation then the non-structure changing applications of the syllabification rules may take place on the first cycle and, because they define derived environments, their outputs may feed - still on the first cycle - other cyclic rules.

The highly significant situation uncovered by Harris in Spanish - syllable dependent cyclic rules changing features on the first cycle - turns out to be widespread : similar results were obtained by Simpson (1979) for Australian English, Kiparsky (1982) for American English and will be presented here in chapter 3, section 5.5. What this shows is that syllabification must be assigned as part of the phonological derivation rather than be an aspect of the underlying lexical entry. Moreover, an examination of the behavior of geminates in underlying and intermediate structures reveals that geminates are not necessarily mapped onto actual positions in the syllable. The analysis of Attic r-Geminata given in chapter 4, section 7 shows that the correct analysis of Attic initial geminate r's is

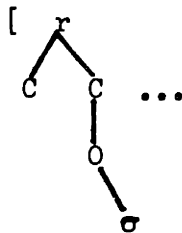

where the first half of the geminate r is syllabically unaffiliated. To deal with such facts, a skeleton-less approach will have to retreat

to the position that geminates are represented as in (60) :

(60)  x an arbitrary segment

The structure in (60) is that of a geminate in advance of syllabification in a skeleton-less format: it is a segment which must eventually be mapped onto distinct positions in the syllable.

We will follow up on this examination of the disadvantages stemming from the lack of a skeleton tier in chapter 2, section 3.2.2.3.

3. Syllable structure and syllabification

3.1. Onsets and rimes

I will assume here a hierarchical, binary branching view of the internal organization of the syllable. In this I follow McCarthy (1979), as well as Kiparsky (1979, 1971) and Prince (1980). This view has been recently challenged by Clements and Keyser, who suggest that no intervening level of structure is necessary between the skeleton and the syllable node. Very little in the Greek material to be discussed here hinges upon the difference between a hierarchical syllable internal structure and the flat one advocated by Clements and Keyser. However, the view of syllabic parsing that I will put forth in section (3.2) has a certain interesting consequence for all theories of syllabic organization which recognize the basic onset/rime distinction. For this reason, I will briefly review here the existing arguments for these syllabic constituents. They are , to my knowledge, two.

The first goes as follows : there are rules which refer to the rime (accent rules, quantitative rules of versification, rules determining what segments may be tone bearers) and there are rules which refer to the onset (Pig Latin and , we may add, the rule which deletes w in certain Greek dialects, to be discussed in chapter 2, section 3). While it is possible to define ad hoc the domains necessary for such rules - for example by stipulating that quantity sensitive rules operate on the projection consisting of the part of the syllable beginning with the nuclear vowel - this is not an answer we want to make large-scale use of. The reason is that the syllable internal domains to be defined ad hoc turn out to be always the same : the pre-nuclear part of the syllable (i.e. the onset) and the nucleus plus the post-nuclear part (i.e. the rime). Unless the domains referred to by Pig Latin or accent rules genuinely reflected syllable internal constituents there would be no reason why in one and the same language some rules could not refer to all of the domains indicated in (61) below :

(61)



- [] domain (a)
- [] domain (b)
- [] domain (c)
- [] domain (d)
- [] domain (e)

In fact, as far as I know, we never need to refer to domains other than (d) and (e) above or the domains contained within them.

The second argument has been given by Kiparsky (1981), who observes that subsyllabic and suprasyllabic constituents are referred to as isomorphic by phonological rules. Elaborating on a point made earlier by Carlson (1978) and Prince (1978), Kiparsky shows that a rule of Finnish lengthening applies to what could be generally characterized as the constituent that follows the accented V (in Kiparsky's terms, "the w that follows the beat"). This simple statement is contingent upon syllable and rime internal hierarchical structure of a binary branching sort.

I adopt without further comment Kiparsky's view that the structure of the syllabic constituents is left dominant within the onset and right dominant within the rime. We will extensively discuss in chapter 4 the question of whether subsyllabic constituents other than the left branch and the right branch are necessary, in the sense of having specific properties associated with them. Let me add that my use of the terms nucleus and coda implies no ontological commitments: these are convenient labels for certain parts of the syllable, not necessarily for constituents.

3.2. Syllabic parsing

3.2.1.

Some of the works known to me in which an explicit syllabification algorithm is proposed are Kahn (1976), Lowenstamm (1981), Cairns and Feinstein (1982). They share one property: the assumption that the entire string is organized into syllables in one scan (or one scan per cycle).

The specifics, on which they differ, are worth examining. Kahn's algorithm, cited below, is partly a specification of certain aspects of the English syllable and partly a parsing device :

(62) Rule I

$$[\downarrow \text{syll}] \implies [\downarrow \text{syll}]$$

|
s

Rule II

$$a. C_1 \dots C_n \begin{array}{l} V \\ | \\ s \end{array} \implies C_1 \dots C_i C_{i+1} \dots C_n \begin{array}{l} V \\ | \\ s \end{array}$$

where $C_{i+1} \dots C_n$ is a member of the set of permissible word initial clusters but $C_i C_{i+1} \dots C_n$ is not.

$$b. \begin{array}{l} V \\ | \\ s \end{array} C_1 \dots C_n \implies \begin{array}{l} V \\ | \\ s \end{array} C_1 \dots C_i C_{i+1} \dots C_n$$

where $C_1 \dots C_i$ is a member of the set of permissible word final clusters but $C_1 \dots C_i C_{i+1}$ is not <23>

(from Kahn 1976: 55)

The procedure can be narrated in English as follows : find a vowel, assign to it the node s (syllable), then attach to s all preceding consonants which do not exceed a possible word initial cluster, then attach to s all following consonants which do not exceed a possible word final cluster. If we abstract away from the restrictions concerning permissible clusters, the procedure is essentially that of constructing a core syllable, V, to which onset and coda are added in ordered sequence: because the onset rule comes first a VCV sequence will always be parsed



Thus Kahn's solution to the formal problem of how to 'maximize the onset' is an ordering solution : onsets are constructed before codas are <24>.

Lowenstamm's algorithm takes the form of a definition of the Universal Syllable template:

(63) In a string of segments a syllable is a maximal substring such that :

- a. (i) no segment is of lower sonority than both its immediate members.
- (ii) no two segments of equal ranking on the hierarchy are adjacent.
- b. the onset is maximal within the limits of (a).

The sonority hierarchy aside, the content of (63) is that onset maximization is a well-formedness condition on syllabification in a string.

Cairns and Feinstein propose a more explicit variant on this. The string is parsed by a syllable template - which, they argue, is language-specific rather than universal, like Lowenstamm's . Such an initial parsing may result in several analyses of the same string. These alternative parsings are called the candidate set. From the candidate set a most highly valued parsing of the string is selected by the following mechanisms. One, a universal evaluation of the relative

markedness of syllabic structures, assigns a markedness index to each syllable and then computes the composite markedness index of each member in the candidate set. The candidate with the lowest composite markedness index is then selected. The second mechanism is language-specific: it states that for certain structures, like the Sinhala nasal-stop onsets, candidate parsings which select them must be, ceteris paribus, preferred.

Again, as the formalization may obscure the main point, I take the liberty to restate what this procedure accomplishes. There are three building blocks in Cairns and Feinstein's theory: the language-specific syllable template, the markedness evaluation of alternative parsings and the language-specific disambiguation clauses. The effective role of the markedness evaluation is again that of achieving the result that VCV sequences are universally analyzed as V.CV. I see no other role that it plays in the parsing. Specific disambiguation statements have also been used by Clements and Keyser (1980) in their analysis of Klamath: the relevant fact there is that, unlike in English, intervocalic biconsonantal clusters are always heterosyllabic, even though complex onsets are attested both word initially and word medially, in longer clusters.

In view of the difference between the assignment of equivalent clusters in English vs. Sinhala vs. Klamath the universal phenomenon of onset maximization boils down to one fact: the universal assignment of V.CV structure to VCV sequences. This, it seems to me, does not warrant setting up the complex mechanism of markedness evaluation.

3.2.2. A proposal

I believe that the formally simpler solution given by Kahn to the disambiguation of VCV sequences is preferable. I propose to develop it as follows: maximally unmarked CV syllables are created by a universal first rule in the sequence of syllabification operations. Since the string is initially parsed by this rule, all intervocalic C's will become onsets before language-specific rules creating codas may become applicable. VCV sequences will therefore be syllabified V.CV by virtue of the ordering between the universal rule creating CV syllables and the language specific rule providing for the formation of codas. This accords with the fact that coda rules, being language-specific, may also be lacking. Thus the first step in the parsing of a string is the application of rule (64):

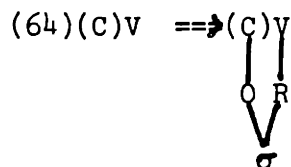

Taking this proposal one step further, we may suggest that the following language-specific aspects of syllable structure result from the existence of ordered language-specific syllable building rules, rather than from template differences : (a) complex onsets and branching codas are created by adjunction rules taking the general form of (65) :

(65) a. Onset Rule

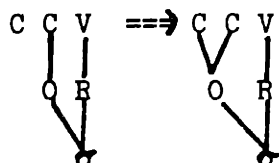

(65) continued

b. Coda Rule

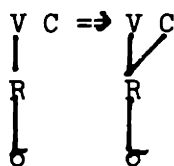

A language may lack either (65.a) or (65.b) or both. Languages may also set different constraints on the applicability of the rules, involving the segmental contents of the C's to be incorporated of the relative sonority of tautosyllabic clusters created by these rules.

(b) Differences in the syllabic assignment of intervocalic consonant clusters - like those between Klamath and English - follow from the different relative order between the Onset and the Coda rule. In English the Onset rule is ordered first, and therefore may bleed the Coda rule in clusters where both are applicable. Klamath has the opposite order between the two operations, which gives priority to the coda rule.

I will refer to the three types of rules mentioned so far, (64)-(65), as the core syllable rules, borrowing the term core syllables from Clements and Keyser (1982). I assume that all three are iterative, in the same two senses in which unbounded foot construction rules are :
(a) each iterates across the string until it covers all sequences to which it is applicable; (b) when possible the rules iterate on their own output in creating larger constituents. Thus English limp is created by two successive operations of a restricted version of (65.b) :

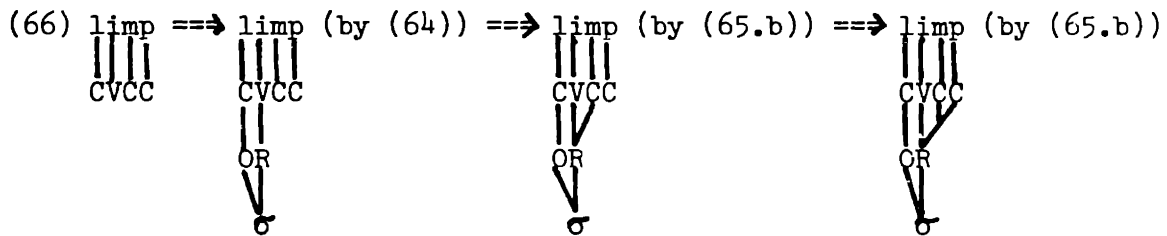

Each C slot is adjoined as the immediate sister of the adjacent syllabified skeleton unit: this creates the right branching structures in the example above.

Syllable templates, which are generally believed to be independent units in the grammar, are used to state the following types of information: how many consonants or vowels are permitted in the onset or rime and what cooccurrence restrictions obtain between adjacent tautosyllabic segments. It is worth considering how much of this information must be stated as part of the syllabic template. Chapters 3 and 4 will demonstrate that for at least three languages, Attic, Mycenaean Greek and Sanskrit, the number of consonants permitted in the onset can be predicted from a correct statement of the cooccurrence restrictions. We will see that the onset rule of these languages can be allowed to freely iterate on its own output: the number of permissible iterations per syllable - and therefore the resultant number of consonants in any given onset - will be restricted by a language-specific constraint on the relative sonority of adjacent consonants. The same result obtains for the Attic coda rule, whose maximum of two iterations per syllable will be predicted from the required distance in sonority between adjacent tautosyllabic consonants.

It is obviously tempting to speculate that when the syllable structure of other languages is submitted to similar analysis, the length restrictions on tautosyllabic clusters will be seen to follow from independent constraints. Clements and Keyser (1982) report - in quite a different framework - the result that the total number of consonants in an English word initial cluster follows from a set of cooccurrence restrictions that mention only two adjacent tautosyllabic consonants. The restriction to a maximum of two members in any word-medial onset - frequent in modern Indo-European languages - can be predicted essentially along the same lines as in Attic. We may have to stipulate that the coda and maybe the onset rule of certain languages is restricted to one application per syllable : this seems necessary in dialects of Arabic like Cairene, where only one non-nuclear member of the rime is admitted. (I assume, following a suggestion of Morris Halle's , that Arabic long vowels are VC sequences, therefore deriveable by the Coda rule as stated in (65.b) Such a restriction is similar to the restriction on binary foot construction and may be stated in identical form as Dominant nodes must be terminal (Hayes 1980 : 78).

There is then reason to believe that length restrictions may be eliminated in the general case from the statement of syllable structure properties. Cooccurrence restrictions, on the other hand, need not be stated in template form. Thus the syllable structure of Attic, need not be represented - in oversimplified form - as (67) :

(67)

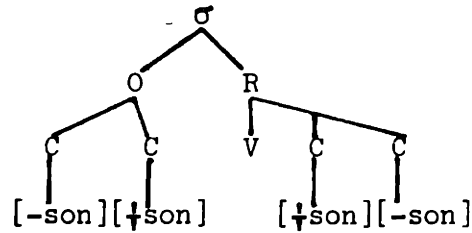

We will see that in Attic a solution like (67) obscures the fact that the same cooccurrence restrictions govern onset and coda clusters. We will also see that the more complex clusters of Mycenaean and Sanskrit cannot be compactly described if the template is given its maximal expansion, i.e. if we list every possible onset and coda cluster. The simplest statement of the syllabic possibilities of these languages turns out to be a condition on the relative sonority of pairs of adjacent consonants, a purely local constraint to which any CC sequence in both the onset and the coda is subject.

My proposal can be summarized as follows : I claim that there are two universal aspects of syllabic parsing: the rule in (64) and the requirement that other core syllable rules must adjoin stray C's as the immediate sisters of the neighboring syllabified skeleton slots. The language-specific properties of syllabification systems have four sources: (a) the presence of any one or both of the adjunction rules in (65); (b) the relative order of these rules; (c) their unbounded or binary character; (d) the existence of specific segmental well-formedness constraints on their application.

Some of the empirical merits of this procedure have been sketched above and will be investigated in chapter 4. I would like to point

out here some of its conceptual advantages: by eliminating templates like (67) and relying on ordering and filters alone as our major tools for differentiating the syllable structures of different languages, we can factor out the universal aspects of the template (namely the fact that syllables consist minimally of a rime and a preceding onset, if a C is found in the relevant position) as well as the language particular information predictable from other aspects of the system (in the case of Attic, that onsets and coda clusters cannot exceed two members). We need not state twice, once in the template and once in the language-specific disambiguation statement, that the syllable structure of a given language includes certain clusters, like the nasal-stop onsets of Sinhala : that fact is contained once, in the Sinhala Onset rule (68). The fact that such onsets are given precedence over the alternative parsing VN.CV follows from the ordering between the Onset and the Coda rule in this language:

(68) Sinhala Onset rule : ordered before the Coda rule

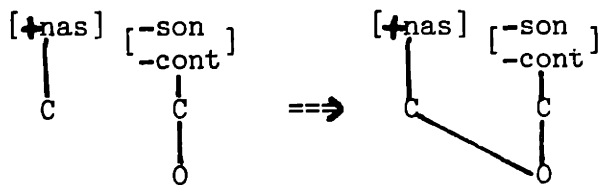

Another result of the procedure suggested is that it, unlike known alternatives, predicts rather than stipulates that the nuclear vowel will always be a member of the right branch. This follows from the fact that stray skeleton slots are adjoined as immediate sisters of the neighboring skeleton slots, rather than as sisters to

the syllable or to any of its constituents. Thus any stray C adjoined to a CV syllable to its left becomes an immediate sister of the V, thereby creating a branching rime rather than a *CVC constituent. Similarly, any stray C adjoined to a CV syllable to its right creates a branching onset rather than a *CCV constituent. The immediate-sister condition on adjunction thus builds left-branching trees in the left branch and right-branching trees in the right branch of the structure created by rule (64). The interaction between this condition and rule (64) predicts that the nuclear vowel will always remain a terminal node of the right branch <25> .

3.2.3. Core syllable rules and stray segments

A proposal which complements the one made in the preceding section is the following :

(69) Core syllable rules apply only to stray segments.

The internal coherence of the system of ordered rules proposed above requires (71): otherwise the fact that the Coda rule follows the Onset rule in English will not be sufficient to explain why an underlying sequence like algebra cannot undergo the following derivation :

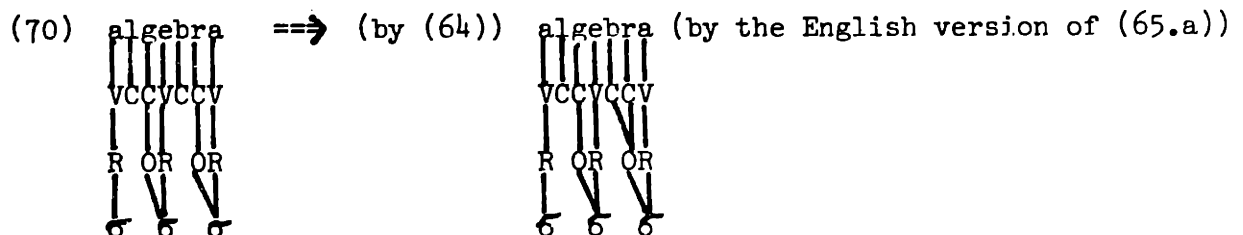
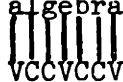

(70) continued

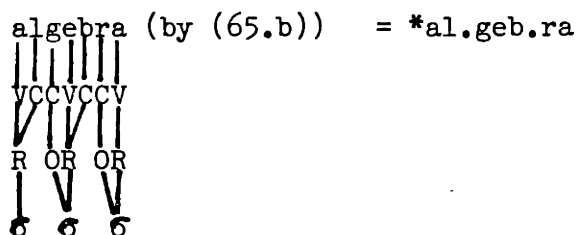

Derivations like (70) should not be permitted in any language that I know of, regardless of whether the cluster incorrectly syllabified by the Coda rule occurs in a derived environment or not. Thus an initial onset cluster of Latin and Greek when separated by a boundary from a preceding vowel does not become subject to the Coda rule any more than the br cluster in English algebra is. More on this in chapter 4.

Since this is a theory internal justification of (69) I will introduce here some independent evidence. The argument for (69) should be centered on the syllabification of derived environments : in non-derived environments a structure changing application of any cyclic rule like (65.a-b) will violate the Strict Cycle.

Part of the evidence is contained in Harris's observation (1982) about the scope of resyllabification in Spanish : Harris notes that the only type of resyllabification attested in Spanish across word boundaries involves the transfer of a word final C to the onsetless initial syllable of the following word, as in en el avion 'on the plane' syllabified e.ne.la.vyon. Branching onsets, even of the type that is well formed word-medially, cannot be created by this process : club lindo 'nice club' does not become clu.blin.do. In our terms, the Onset rule

does not apply to change the coda status of the first word.

Identical facts are attested in Latin : across a prefix or a word boundary stop] [liquid clusters remain heterosyllabic as in ob-ligō 'I fasten', consistently scanned ob.li.gō by the meter. Cairns and Feinstein (1982) also note that the Sinhala Onset rule which derives nasal-stop onsets should be blocked from reapplying to change structure : the derived form /and-wa-/ 'put on-CAUS' is initially syllabified an.d.wa with an unaffiliated middle d; it becomes an.d.da by the gemination of the Cw sequence, after which the unsyllabified middle d is lost. The result is an.da, rather than a.nda , indicating that the Sinhala Onset rule has not reapplied in the output of the stray d deletion to the syllabically attached nasal.

3.2.4. Ordering Constraints

The sequence of ordered core syllable rules proposed can be conceived of , much like Kahn's, as a single syllabification process applying in block. But if the rules proposed are similar in character to metrical foot construction rules, as suggested by their iterative mode of operation and by their possible division into binary and unbounded, it is also possible that they are operations independent of each other and that, consequently, there is no unitary syllabification process but simply a set of structure-building rules ordered within the phonological component. Whatever evidence bears on this point will be presented in chapter 3.

In this section I would like to take up a possible objection to such a view of syllabification: namely that what we call syllabic parsing cannot be a set of ordinary phonological rules because, unlike phonological rules, they apply at any point in the derivation when their description is met <26>. To my knowledge, the demonstration that this is so has not been made : what is required is a case in which the same syllabic structure is created twice on the same cycle. I know of no such case.

Moreover, Prince (1980) mentions a fact which conflicts with the assumption of continuous syllabification. In the interest of brevity I will assume here some acquaintance with Prince's analysis of Estonian quantity rules. The relevant background is that underlying rimes created by the first scan of syllabification undergo the Estonian quantity rules as follows: (a) the entire non-nuclear part of the rime is lengthened except that (b) a sonorant lengthens iff it exhausts the right branch of the rime (i.e. in

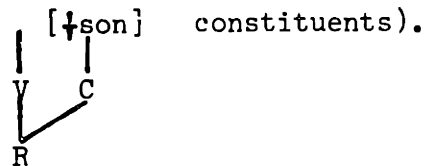

Examples of lengthening are : pat:tu 'sin' (based on the syllabification pat.tu), lap:si 'child' (lap.si), söö:ma 'eat' (söö.ma), vaa:k:suma 'to croak' (vaak.su.ma), tark:ka 'wise' (tark.ka), lin:tu 'bird-Part.sg.' (lin.tu), tönt:si 'dull-Part.sg.' (tönt.si), suu:nta 'direction' (suun.ta). The significant fact is that forms like õn:tsa 'happy' , vem:pla 'cudgel', which are derived by syncope from /õntisa/, /vempela/ behave as if they differ in syllable structure from tark:ka, tönt:si.

Their sonorants undergo the Quantity rule as if the syllable cut is still ən.t..., vem.p..., as before syncope. An ordering solution to this problem - placing the Quantity rule before syncope - will not do, as Prince argues that the former is a 'late rule of phonetic interpretation'. There are in fact several solutions to this problem: Prince chooses to allow stray segments in the output of syncope (hence vem.p.la). We may suggest the alternative of a rule of Stray Segment Adjunction (as proposed by Kiparsky 1981), which would adjoin the stray p to the syllable rather than to the adjacent m. The output, (71), will still fail to meet the Lengthening rule :

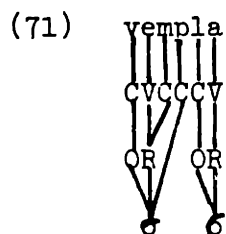

The essential point however is that, on any account, the core syllabification rules have not reapplied to the output of syncope. We might add that, according to Prince 's account, syncope is morphologically conditioned and therefore most likely a cyclic rule.

This is obviously not an argument for conceiving of the core syllable rules as independent phonological processes with distinct ordering privileges: it is however an indication that the prevalent view on continuous syllabification, which is inconsistent with our proposal, may be unwarranted.

3.3. Exhaustive syllabification and Stray Erasure

Harris (1982) and Cairns and Feinstein (1982) illustrate the use of a convention, which I believe harks back to McCarthy (1979), whereby unattached segments are deleted. I will assume and make heavy use of it under the name of Stray Erasure Convention and under the following formulation :

(72) Stray Erasure Convention

Erase segments and skeleton slots unless attached to higher levels of structure.

By higher levels of structure I mean either a position in the syllable or one in a morphological template. The latter possibility is illustrated in chapter 4, where the place of the Stray Erasure Convention in the derivation is discussed.

The adoption of Stray Erasure implies that in the immediate output of its application all segments and skeleton slots are attached. In particular, since I assume that Stray Erasure applies at the end of the cyclical component and then again at the end of phrasal phonology, this means that in surface structure all strings are exhaustively syllabified. This may have been a self-evident truth until recently but can no longer be taken for granted. Chapter 4 is, among other things, a demonstration that there exist stray segments at intermediate levels of representation, after the core syllable rules have applied.

Let me then briefly justify the idea of surface exhaustive syllabification. The examples, in this case, come from languages which allow at the beginning and at the end of words consonants that cannot be syllabically incorporated by the core syllable rules.

In English, for example, s-stop clusters are in general heterosyllabic word medially, indicating that they cannot qualify for the Onset rule. Word-initially, such clusters are frequent and behave with respect to language games like Pig Latin exactly like regular onsets do: the Pig Latin version of spin is inspay not *sinpay, in parallel to that of trim, imtray, a word which begins with a possible word medial onset. Thus s is not stray but adjoined to the onset in the input to a late process like Pig Latin.

A different test indicates similar results in a dialect of Arabic, Baskinta, in which all biconsonantal clusters are heterosyllabic word-medially. Baskinta, like most Arabic dialects, lacks an Onset rule. Biconsonantal clusters are possible word initially : ktaab 'book', ntafa 'he benefitted', m̃siina 'we walked'. We can tell that the initial members of such clusters are not extrasyllabic at late stages in the derivation by considering the effect of a rule of pharyngealization which spreads within the confines of a syllable the underlying pharyngeal quality of a segment. This rule is extensively illustrated by Abu Haidar (1979), my source for Baskinta. When a monconsonantal prefix appears on a word whose initial syllable is pharyngealized, it too will surface as pharyngeal, as if it belongs to the initial syllable : /t-kassar/ 'passive-to smash' surfaces as tkassar (the pharyngealized portions are underlined). However if epenthesis applies

in a VC][CCV phrase and yields VCiCCV the word initial cluster is heterosyllabic, as in word internal position: as a result initial preconsonantal prefixes do not undergo pharyngealization in such structures, as illustrated by 'aliil il-xasiyyi ('a.lii.lil.xa.siy.yi) 'lazy'.

Similar examples from Berber can be found in Saib 1978.

The tautosyllabic behavior of initial clusters not derived by an Onset rule with respect to late rules indicates that rules analogous to Hayes's (1980) Stray Syllable Adjunction incorporate their stray members. A proposal along these lines has been made by Kiparsky (1981) .

The assumption of exhaustive surface syllabification is also motivated by the pattern of consonant loss that I attribute to Stray Erasure : the consonant suspected of being lost by failure of syllabification is always either word initial and followed by another consonant, or word medial flanked by two consonants.

Under rare circumstances I will have to attribute to Stray Erasure the loss of a consonant in postnuclear position.

The key fact is that the clusters simplified can be shown independently to contain one or more segments to which neither the core syllable rules nor the Stray Adjunction rules may apply : these are invariably the segments that are lost.

3.4. The Sonority Hierarchy

(The languages whose syllabification systems will be discussed in the following chapters - Greek, Latin, Sanskrit - obey what Selkirk has termed

the Sonority Sequencing Generalization (SSG) :

(73) The Sonority Sequencing Generalization

In any syllable there is a segment constituting a sonority peak which is preceded and/or followed by a sequence of segments with progressively decreasing sonority values.

(Selkirk 1982:16)

Versions of this principle have been known at least since Saussure's Cours d'Introduction and its relation to the process of syllabification has not escaped attention <27> . However, while the need for the syllable as a unit of segment organization is now widely recognized, the status of the SSG as a part of universal grammar remains unclear. The reason is primarily because its validity as a universal has frequently been questioned: for example, Indo-European languages like English allow s-stop clusters at the beginning of words and stop-s clusters at the end of words even though all proposed sonority scales place continuants higher than non-continuants. In Russian such apparent counterexamples to the SSG, while restricted to the word edges, take most extreme forms: mgl, mzd, rž, l'st are possible word initial clusters (as in mgla 'mist', mzda 'recompense', ržavyj 'rusty', l'stit 'to flatter'); br, bl, pl are possible word finals (as in zubr, 'bison', rubl' 'ruble', vopl' 'wail' <28>).

I would like to suggest that most difficulties encountered by the SSG have their sources in two types of misunderstandings about its content. First, I will argue that the scale on which sonority values are measured has one parameter on which languages may vary. Thus , in the absence of a theory of possible sonority scales one cannot tell

whether a given tautosyllabic cluster violates the SSG or is consistent with it, modulo a sonority scale different from the one investigators tacitly assume.

Second, I will give some evidence that the syllabic structures which violate the SSG under all assumptions are created by late adjunction rules: in this they contrast with clusters that have become tautosyllabic early in the derivation, by the operation of the core syllable rules. Let me mention here one clear example, deferring the remainder of the evidence until chapter 4 : the word initial and word final violations of the SSG in Russian arise from the operation of a postcyclic rule which deletes high lax vowels. The post-cyclic character of this vowel deletion rule has been demonstrated, for example by Pesetsky 1979, where the observation is also made that , until this late rule applies, the syllable structure of Russian does not violate the SSG. Chapter 4 will give slightly different reasons to believe that postcyclic syllabification rules are not constrained by relative sonority: in Greek, Sanskrit and Latin the onsets created cyclically are all subject to the SSG , although the sonority scales of the three languages differ. But they represent only a subset of the underlying word initial clusters: some of the consonants left stray after the operation of the cyclic core syllabification rules are adjoined to syllables by postcyclic Stray Adjunction rules. It is these rules which are responsible for the s-stop initials of Indo-European languages. While the reason for this correlation between cyclic rules and rules subject to the SSG remains unclear, the very fact that the counterexamples to this principle are concentrated in one component of the phonology allows us to maintain it.

In the remainder of this section I will outline a proposal for relativizing the sonority scales against which principles like the SSG are evaluated, so that different languages are allowed a limited freedom in computing the relative sonority of tautosyllabic clusters. My starting point are Harris's observations on tautosyllabic clusters in Spanish (1982) and Selkirk's comments on them.

Harris notes that five filters by means of which he proposes to handle most facts of Spanish syllable phonotactics have in common the fact that they rule out sequences of sounds that are too similar to each other, like iy ,uw in the rime , [↓alveolar][↓alveolar] in the onset. Selkirk suggests that the formal means required to characterize dissimilarity constraints are sonority indices. She proposes a sonority scale, given in (74), to whose entries she assigns integer values. The proposal is to give dissimilarity requirements the form : Position X in the onset/rime must be at least n points apart from adjacent position Y in the onset/rime on the sonority scale.

(74) sound	sonority index
a	10
e,o	9
i,u	8
r	7
l	6
m,n	5
s	4
v,z,ð	3

(74) continued

f,θ	2
b,d,g	1
p,t,k	.5

The table in (74) is proposed as part of a larger program to eliminate major class features in favor of syllabic representations in which non-terminal nodes in the syllable have sonority annotations: for example the first position in a Spanish rime has the associated index 8, which means that it must dominate a vowel. My discussion here will focus on the statement of dissimilarity conditions, which is a logically independent issue from the existence of major class features. One such feature, [syllabic], has been defended above and will do important work for us in chapter 2.

The statement of dissimilarity requirements in terms of positions on a sonority scale will receive considerable support in this study. However, when we compare the differences between the statements required for Greek, Latin and Sanskrit we see that one sonority scale with fixed universal values is not the answer. The main empirical problem which Selkirk's proposal faces is that different languages seem to assign contradictory values to the same entries on the scale.

We consider first the difference between Greek and Latin : Latin requires that all and only stop - liquid clusters be onsets. Greek, whose facts will be discussed in detail in chapter 3, requires

that all voiced stop - r, voiceless stop - nasal clusters be onsets and allows voiced stop - l onsets. On the table in (74) only the Greek facts can be expressed : a Minimum Sonority Difference (MSD) of 4.5 points computed on that table will allow voiceless stop -nasals and voiced stop - l onsets as well as onsets whose members are more distant on the sonority scale (like stop - r). The Latin MSD is however unstateable on that same table. To allow both bl and pl clusters and to disallow pn from being tautosyllabic we may settle on a MSD of 5 points. But fr clusters, separated by the allowed 5 points difference, are also predicted to be tautosyllabic. The metrical evidence shows otherwise: words like Africa are scanned Af.ri.ca throughout the history of Latin poetry, compounds like re-frenō 'I restrain' are scanned ref.re.nō in the preclassical poetry, our best testimony for Latin syllabification <29>

We will consider in chapter 4 the onset inventory of Mycenaean and Sanskrit and discover [-coronal][+coronal] clusters of either obstruents or nasals, even though other aspects of the onset inventory indicate that a MSD requirement of at least 1 point governs the syllabification rules. Selkirk's scale does not contain separate entries for the coronal and non-coronal members of each major class but, if we introduce such entries, we make it impossible to state the MSD requirement of Greek . The reader can check this against the scale in (75) :

(75)	p,k	.5
	t	1
	b,g	2
	d	3

(75) continued

f	4
θ	5
v	6
z, ð	7
s	8
m	9
n	10
l	11

Some experimentation with the candidates for universal sonority scales in (75) and (74) should convince one that the answer lies not in manipulating the sonority values associated with each entry : no matter what fixed values and what scale we settle on the facts of Mycenaean seem incompatible with those of Greek , which are irreconcilable with those of Latin.

A solution can be found if we give up on the idea that matters of relative sonority should be dealt with by a single scale with absolute values. Some of the difficulties outlined above come from the fact that distinctions which translate into sonority differences - like voicing, continuancy , nasality , coronality - do not always seem to play a role in the relative sonority computations required for different languages, Thus, if the sonority scale of Latin could be allowed to differ from that of Greek in the inclusion of the feature [voice] we could solve the first problem raised. I give below the

sonority scales of Greek and Latin : they differ only in the presence of the feature [voice] in the Greek scale and in the presence of [coronal] on the Latin scale :

(76) Latin sonority scale

[-son,-cont,-cor] : p,k,b,g
 [-son,-cont,+cor] : t,d
 [-son,+cont,-cor] : f
 [-son,+cont,+cor] : s
 [+son,-cont,+nas,-cor] : m
 [+son,-cont,+nas,+cor] : n
 [+son,+cont,-nas,+lat] : l
 [+son,+cont,-nas,-lat] : r

(77) Greek sonority scale

[-son,-cont,-voice] : p,t,k
 [-son,-cont,+voice] : b,d,g
 [-son,+cont,-voice] : s
 [-son,+cont,+voice] : z
 [+son,-cont,+nas] : m,n
 [+son,+cont,-nas,+lat] : l
 [+son,+cont,-nas,-lat] : r

The MSD requirement can now be stated as 6 intervals for Latin and as 4 intervals for Greek : this will allow all the stop - liquid clusters of Latin to be onsets except tl,dl (a correct result, as we shall see in chapter 3) and none of the stop -nasal or continuant - r clusters.

In Greek, the scale in (77) will put a 4 interval distance between voiceless stops and nasals, voiced stops and l, s and r. The first two classes of clusters are tautosyllabic, the third unattested. Clusters separated by more intervals than the minimum 4 (in Greek) and 6 (in Latin) are also tautosyllabic.

We will see in chapter 4 that scales of this type solve a number of seemingly intractable problems in Mycenaean and Sanskrit. In closing this section let me point out that this approach to relative sonority is quite easy to falsify: implicit in the two scales presented is the claim that the hierarchy of features present on a scale is fixed universally. We could not set up a scale in which continuancy distinctions take precedence over obstruency distinctions, as in (78) :

(78) An impossible sonority scale

[-cont,-son,-cor] : p,k,b,g

[-cont,-son,+cor] : t,d

[-cont,+son,-cor] : m

[-cont,+son,+cor] : n

[+cont,-son,+cor] : s

[+cont,+son,+cor] : r,l

Also we could not introduce one feature in only half of the scale, thus establishing, for example a one interval distance between p,k and t but not between n and m, w and y.

Thus the only allowable parameter of difference between sonority

scales as viewed here is the inclusion of an individual feature - including, pace Selkirk, that of major category features like [sonorant] - as a dimension of sonority.

4. Lexical Phonology

I adopt here in its principal aspects the model of lexical phonology elaborated by Pesetsky 1979, Kiparsky 1982, Mohanan 1982. This is a view of phonology which places cyclic rules within the lexicon, where their application accompanies the each morphological operation. Morphological processes are organized in sets called levels or strata, and ordered as blocks with respect to each other.

For present purposes I define level 1 in Greek phonology as that of the least productive derivational processes; level 2 as that of inflectional morphology and of some highly productive deverbal abstracts; level 3 as that of compounding and prefixation.

I follow Mohanan in assuming that levels define the domains of application of phonological rules: a certain rule may enter the derivation (i.e. become applicable) at level n and it may exit at level $n+1$. Between these two points it is expected to be applicable whenever its environment is met, subject to the Strict Cycle.

I also follow Mohanan in his elaboration of Pesetsky's idea that at the end of each level internal brackets of morphological constituents are erased so that later levels cannot access anything but the information contained in the phonological string itself.

I will refer to this principle as the Bracketing Erasure Convention.

Chapter 1 - Footnotes

1. Withgott (1982) proposes the term branching segments to designate the structures in (4). I have decided to replace it with contour segments since branching segment suggests misleadingly a unit at the segmental level which branches, therefore a geminate, as in (5).

2. See below, page 92 .

3. <c> spells k in the Latin orthography. Surface forms are cited here in traditional Latin spelling, for easier identification.

4. Forms like lingula, in which the vocalized glide w surfaces as short u, show that the long ū in secūtus results from a morphologically restricted lengthening rule.

5. I show in the work cited that rule (7) is in fact more general, since it applies to any unsyllabifiable u, and not just to the second element of a labiovelar.

6. Like the Obligatory Contour Principle, a principle devised by Leben (1973) for tonal phenomena, and held by Leben (1980) to apply to the melodic core as well. The Obligatory Contour Principle prohibits adjacent identical tonal or segmental units and would automatically turn (15) into (14). Its invalidity was shown by Schein (1981) and Hyman (1982). See below page 32 .

7. See the comments of Clements and Keyser (1982:1) on the SPE distinction between strong and weak clusters as a paradigm case of

the insufficiency of linear representations.

8. I have not discussed in the text the alternative of analyzing the geminates to which the AIC applies as phonologically long segments: the theory espoused here simply does not have a feature [±long] available. The reader is referred to Saib 1977, an extensive demonstration that even if such a feature was available it could not adequately characterize the behavior of geminate consonants.

9. Cf. Chomsky and Halle (1968:344): "(39) To apply a rule, the entire string is first scanned for segments that satisfy the environmental constraints of the rule. After all such segments have been identified in the string, the changes required by the rule are applied simultaneously."

10. Morris Halle (p.c.) points out the following facts from Hebrew which might represent a problem for my account of the blockage of Spirantization. Hebrew has a rule of postvocalic Spirantization which, unlike that of Tigrinya, applies to all postvocalic non-emphatic stops (see McCarthy 1981 and Leben 1980). This rule shares with Tigrinya Spirantization the property that it fails to affect a geminate cluster (cf. dibber 'he said' represented as



in McCarthy 1981) when only the first member of the cluster satisfies its environment; like in Tigrinya, the rule does affect geminates when both Cs of the geminate sequence are postvocalic (cf.

libeb 'hearts' [liβeβ], analyzed by McCarthy (op.cit.) as

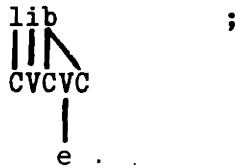

on the split geminate in forms like libeb see below.). The potential difficulty comes from the fact that Spirantization also applies to the third C in a trigeminate sequence like the one in sibbeb 'to turn', surface [sibbeβ]. sibbeb is the linearization of the pi9el form (prosodic template corresponding in Hebrew to the Arabic 2nd binyan) of the biconsonantal root /sb/. If the autosegmental representation of sibbeb is, as McCarthy (1979 : 269) argues,



(22.a) will prevent Spirantization from applying not only to the first instance of b but also, incorrectly, to the third.

The solution to this problem lies in the following observation: when a Semitic root with n consonants must be mapped onto a prosodic template with n + 2 C slots there is a morphologically determined choice between 'trigeminate' forms like sibbeb and root reduplication, as in the binyan known in traditional Hebrew grammar as the pilpel. Thus the biconsonantal root /gl/ 'to roll' becomes in the pilpel form gilgēl 'to roll (trans.)'. Another case of root reduplication meant to fill a template whose slots exceed by 2 the root consonants is discussed by McCarthy (1979 : 275) under the tradi-

tional name of pəʔalʔal: the pəʔalʔal form of the first binyan form sāḥar 'to go about' is səḥarḥar 'to palpitate'. Departing slightly from McCarthy's analysis of such forms we can analyze gilgēl and sə-ḥarḥar as resulting from the reduplication of the root consonantism:

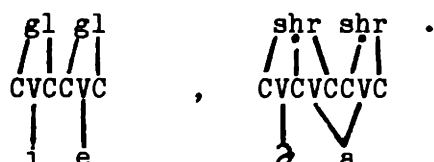

We note that in səḥarḥar the association between the reduplicated root melody and the last two C slots takes place from right to left:

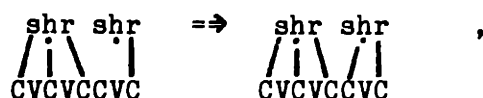

in accordance with Marantz's (1982) general observations on the directionality of the mapping between skeleton and reduplicated melodies. Suppose now that we extend this analysis to cover the apparent trigeminate forms like sibbeb:

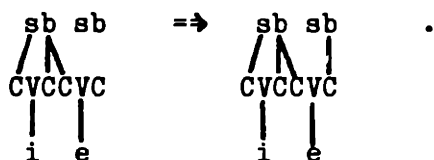

As in the case of səḥarḥar the regular right to left mapping of the reduplicated melody to the skeleton will give priority to the rightmost segment, b, over s. Since only one C slot needs segmental filling, the reduplicated s will remain unassociated and will be erased. The difference between the more frequent forms like sibbeb and the less frequent type gilgēl lies in the order between the association of the third C slot in the template and reduplication: in sibbeb the third C is already associated to the (unreduplicated)

root melody when reduplication applies; in gilgēl reduplication encounters both the third and the fourth C slots empty. This difference can be attributed to a difference in the order between reduplication and linking: in gilgēl the reduplication of the root melody takes place before linking thus

$$\begin{array}{c} \text{gl gl} \\ / \quad \backslash \\ \text{CVCCVC} \end{array} \text{ becomes } \begin{array}{c} \text{gl gl} \\ / \quad | \\ \text{CVCCVC} \end{array}, \text{ then } \begin{array}{c} \text{gl gl} \\ / \quad | \quad | \\ \text{CVCCVC} \end{array} \text{ and finally } \begin{array}{c} \text{gl gl} \\ / \quad | \quad | \\ \text{CVCCVC} \end{array}.$$

In contrast the reduplication of sibbeb takes place only once the root final b has been twice attached:

$$\begin{array}{c} \text{sb sb} \\ / \quad \backslash \\ \text{CVCCVC} \end{array} \Rightarrow \begin{array}{c} \text{sb sb} \\ / \quad | \quad | \\ \text{CVCCVC} \end{array}.$$

We can explain this by proposing that no segment can be linked to more than two skeleton positions. Thus root reduplication is resorted to, in the general case, only when the root has run out of eligible consonants, where eligible means consonants that are not already associated with two skeleton positions. Note that a restriction like the one I postulate seems necessary quite independently of the analysis of Hebrew Spirantization and the validity of principle (22.b). We need to explain why biconsonantal roots do not have quadrigeminate forms even though the requisite templates exist: the 11th binyan of a quadrilateral root like /dhrj/: dharjaj should, in the absence of any constraint on multiple association, correspond to a form like *smammam of the biliteral root /sm/. If we restrict multiple linking to the maximum of two-to-one linking stipulated above we explain the absence of forms like *smammam and we obtain the representations like



to which Spirantization can apply in accordance with (22.b) to yield [sibbeβ].

11. Saib writes /bddl/, /fzz/ rather than

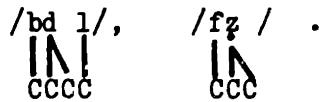

12. I adopt here the basic idea of Halle and Vergnaud's (1982) treatment of Berber epenthesis.

13. I am interested here only in the process of voicing assimilation. The geminate interdental resulting from underlying d θ,

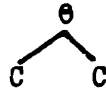

is turned into a non-continuant by a separate rule.

14. A case quite similar to that of the Berber infixation is discussed by McCarthy (1981). It involves the plurals of nouns of CVC C form in Classical Arabic: some of these nouns form their plurals by a general pattern which consists of inserting a long vowel (whose vocalism is unclear from McCarthy's discussion) before

the root final C. The results are, in the case of geminate final roots, split geminates like: pl. xuṭuut from sg. xatṭ 'line', pl. ruquuq from sg. riq 'parchment', pl. zilaal from sg. zill 'shadow'.

15. The process of schwa insertion takes place in Berber from right to left: this is why, of the two unsyllabified consonants in post-syncope



the rightmost, θ, is encountered first and triggers first epenthesis:



16. Two other forms lend additional force to this point: one is ettbeddal, mentioned above page 37, derived from underlying



by Epenthesis (I ignore here the difference in tiers between affixal and root consonantism). ettbeddal, which contains an underlying true geminate, shows the same exceptional pattern of Epenthesis as amazigetmazigθ: schwa is inserted before the triconsonantal cluster rather than in the middle of it. The other form is surface eθx-edmem 'you pl. masc. worked' derived by epenthesis from underlying

/θ-xdm-m/. Right to left application of Epenthesis yields progressively

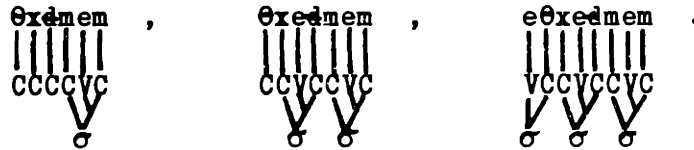

The point supported by eθx̄eθdmem is that the adjacent identical segments

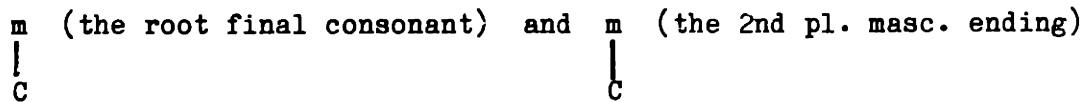

do not behave like true geminates with respect to epenthesis: they have not undergone an assimilation rule which could have linked them segmentally.

17. The lack of epenthesis in word final geminate clusters (tafutt, eqqett, esfeṭṭ) cannot be used as a diagnostic for their structures: even if such sequences contained unlinked matrices, epenthesis would not apply, as it does not in amazigθ, θaxaθarθ 'tent', takurt 'ball'. Berber phrases, like English words, appear to permit a final extrametrical coronal.

18. The germs of this argument are found in Schein's analysis of gemination and spirantization in Tigrinya (1981): some of the true geminates of Tigrinya, recognizable as such by their failure to undergo spirantization, result from what seems to be a general point of articulation assimilation rule. From the fragmentary data available on the phonetics of Tigrinya it was unfortunately impossible to establish that the process of assimilation which derives the gem-

inate of yəqqayädu, for example, from /y-t-qayädu/ 'attach-imperfect' is in fact a partial assimilation rule.

19. iṭtan, aṭtan, mintan and mintna result from Voicing Assimilation and Degemination: thus /iḍḍ-tan/ becomes iṭṭ-tan and is then degeminated to iṭtan.

20. I follow here the linear notation used by Kenstowicz and Pyle (1973) and by our major source for Kolami, Emeneau (1955).

21. This observation is made by Emeneau (1955).

22. I follow here the statement found in Whitney (1889 : 170): "Before the guttural and labial surd mutes (...) it (viz. g) is also theoretically assimilated becoming respectively the jihvāmūliya and upadhmanīya spirants (that is χ and φ D.S.)."

23. I omit Kahn's resyllabification rules as irrelevant here.

24. My reference to onsets and codas is not an accurate representation of Kahn's view on the matter: Kahn's syllables have no internal structure. However, since the issue discussed here, parsing, is independent of the question of syllabic constituents I take the liberty to adopt a uniform terminology where no crucial distortions ensue.

25. Note that Kiparsky's algorithm (1981, 1979) for the construction of syllable templates, whose resulting structures are identical to those produced by the procedure discussed in the text, cannot

predict that the most sonorous terminal node will occur on the right branch. Kiparsky's algorithm relies exclusively on the representation of the relative sonority of adjacent segments. For a syllable like bag metrical representations of the pattern of relative sonority can be either

	o			o	
	s			s	
w s w		or		w s w	.
b a g				b a g	

Only the latter is correct.

26. The continuous syllabification principle is assumed in McCarthy (1979) and Hayes (1980).

27. It has been discussed under the name Strength Hierarchy by Hooper (1972). Kiparsky (1979, 1981) advances the hypothesis that the SSG is in fact a formal consequence of the existence of sub-syllabic metrical structure.

28. D. Pesetsky, to whom I am indebted for this data, informs me that the standard poetic conventions of Russian do not count as syllabic the consonantal sonorants of mzda, zubr.

29. I follow here Allen (1973) who points out that traditional statements of the muta cum liquida clusters of Latin lump together stop-liquid and f-liquid sequences on the basis of classical and

postclassical scanning of compounds like bi-frons 'with two foreheads'.
As Allen notes, the only uncontrovertible evidence comes from tauto-
morphic f-liquid clusters, which are heterosyllabic.

Chapter 2

Compensatory Lengthening and Resyllabification Types in Greek

1. Introduction

This chapter will support the following proposition:

- (1) An empty C slot in the rime is associated with the segment in nuclear position. Formally,

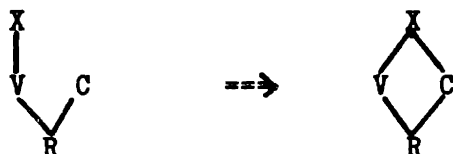

I will argue here for the validity of (1) in Greek, although I believe there is some reason to consider it a universal convention^{<1>}. I will focus on the two instances of Compensatory Lengthening (CL), the phenomenon (1) formalizes, which are the best arguments in favor of the general statement given above: any empty C slot preceded by any tautosyllabic vowel gives rise to CL. In the two cases to be discussed CL results from the resyllabification of a segment from syllable final position to the syllable initial position of an onsetless syllable:

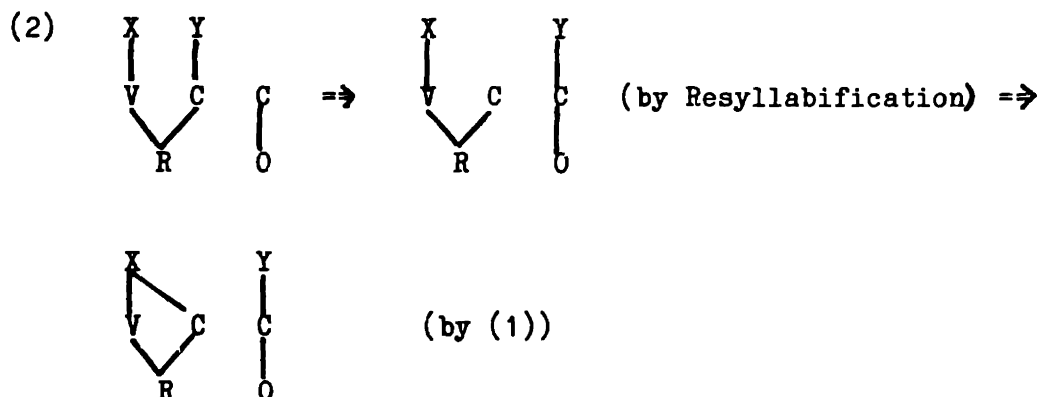

We will see that by considering the cases of CL brought about by Resyllabification we can broaden our data base concerning possible types of CL and we can support both the general idea that mechanisms like (1) are necessary and the specifics of our statement of (1).

The place of CL in our analysis of Greek syllabification processes was indicated in the Introduction (p. 9): if (1) is adopted then any consonantal segment lost in postnuclear position without CL effects must have vacated a C slot that did not belong to the Rime. This type of reasoning will be frequently invoked in the next chapter, as we analyze the processes which give rise to Greek codas.

A number of incidental results, concerning both the analysis of Greek syllabic structure and the theory of syllabification, will also be reached: I will introduce them as we proceed.

2. Compensatory Lengthening and the Empty Node Convention.

The immediate antecedent of the condition in (1) is the Empty Node Convention proposed by Ingria (1980) in his analysis of

Compensatory Lengthening:

(3) The Empty Node Convention

"Empty w nodes which are part of a syllabic coda are to be associated with the terminal element dominated by the immediately preceding syllabic nucleus. All other empty nodes are to be pruned."

(Ingria 1980 : 471)

Notational differences apart, like the fact that I replace the reference to syllable internal metrical structure ("empty w nodes") by reference to skeleton positions ("an empty C slot"), the ideas behind (1) are very similar to Ingria's conception of CL, as encoded in his Empty Node Convention (ENC). What makes it necessary to bring new evidence to bear on these issues is that Ingria's original evidence for CL from Greek was open to a variety of interpretations, not all of which were compatible with either the ENC or with (1).

The cases of CL in Greek discussed until now (in works like Kiparsky 1967, DeChêne and Anderson 1979, and Ingria 1980) are limited to the consequences of a consonant loss in coda position. They include: (a) the CL effects following the loss of n before g as in h_{ens} => h_{es} 'one'; (b) the CL effects following the loss of h as in esmi => e^hmi => ēmi 'I am'; (c) the loss of a metathesized glide, h (according to Kiparsky 1967) and w (according to Ingria (1980)), as in āngelsa => āngelha => āngehla => āngēla 'I announce'; or as in korwos => kowros => kōros 'boy'. Most of the rules mentioned will be discussed more fully below. For the moment let us note that the evidence that these facts provide for either the ENC or for (1) is

not overwhelming. Thus DeChêne and Anderson (1979) suggest that universally CL can be attributed to rules of monophthongization between a nuclear vowel and a glide or a glide-like segment in post-nuclear position. On the assumption that the pre-g nasal of words like hens went through a glide-stage<2>, the facts listed above seem perfectly compatible with this hypothesis, which makes mechanisms like (1) unnecessary. Even if conventions providing for the association of empty nodes in rime position are needed elsewhere<3>, it may seem striking that all the well-motivated cases of Greek CL result from the loss of a sonorant. In fact there are clear cases of obstruent loss in what appears to be coda position which do not lead to CL: thus stops are lost in absolute word final position (sōmat => sōma 'body'; galakt => gala 'milk') and coronal stops are lost before non-coronal stops (kekomid-ka => kekomika 'I have provided') and in neither case do we observe CL effects. This raises the possibility that CL is limited to the loss of a sonorant coda. If CL were so restricted, the conventions proposed to explain it would have to be revised in ways that are not immediately obvious.

I have given above an outline of the difficulties we have to overcome in supporting (1) as the correct statement of the phenomena of compensatory lengthening in Greek. What I propose to show in this chapter is that CL is attested in the output of resyllabification, a fact that directly contradicts DeChêne and Anderson's monophthongization theory. We will also see that the resyllabification of any consonant, including that of obstruents, will lead to CL. Thus the facts of resyllabification will require a general statement

of CL as in (1). The difficulty raised by the loss of stops in cases like sōma and kekomika will be eliminated in Chapter 3.

3.1 Loss of w in Ancient Greek

An onset w was lost in several Greek dialects before our earliest records: Ionian, Aeolic and Attic have preserved w only in the weak position of the nucleus. Elsewhere, a Common Greek w, as reconstructed from Mycenaean and other dialectal evidence had been deleted or assimilated to a neighboring consonant<4>. The effects of the Onset w Deletion are illustrated in (4):

- (4) a. wanaks 'lord' (Myc. wa-na-ka) => anaks all dialects
wastu 'city' (Myc. wa-tu) => astu all dialects
werg- 'work' (Myc. we-ka-ta 'worker') => erg- all dialects
woikos 'house' (Myc. wo-i-ko) => oikos all dialects
- b. elaiwon 'oil' (Myc. e-ra₂-wo) => elaion all dialects
newos 'new' (Myc. ne-wo) => neos all dialects
klewos 'renown' (Myc. -ke-re-we) => kleos all dialects

- c. dweyos 'fear' => deos all dialects
swekuros 'father-in-law' => ^hekuros all dialects
- d. dedwoika 'I feared' => dedoika Attic
dedwimen 'we feared' => dedimen Attic
odwos 'threshold' => odos Attic, ōdos Ionic
wiswos 'equal' (Myc. wi-so-wo) => isos Attic, ἴsos Ionic.
- e. ksenwo- 'stranger' (Myc. ke-se-nu-wi-ja) =>
ksenos Att., ksēnos and ksenos in Ionic.
stenwos 'narrow' => stenos Att., stēnos and stenos Ion.
perwat- 'limit' => peratos Att, pērata Ion.
derwā 'neck' => derā Att., dērā and derā Ion.
orwos 'boundary' => oros Att., ōros and oros Ion.
kalwos 'beautiful' (Beot. kalwos) => kalos Att.,
kālos and kalos Ion.
- f. wrīnos 'hide, skin' (Myc. wi-ri-ne-jo) => rīnos Attic
wrīzda 'root' (Myc. wi-ri-za) => rīzda Attic

W was lost in both Attic and Ionic with no effect on the neighboring sounds when it was preceded by an open syllable or by no syllable. CL accompanied the loss of w in Ionic whenever w was preceded by a consonant (ōdos, ksēnos). In Attic and Aeolic the loss of w did not lead to CL.

I state the rule of Onset w Deletion in (5):

(5) Onset w Deletion

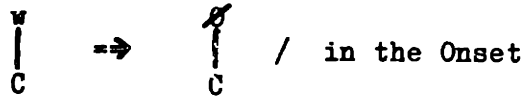

Note that the statement of (5) must be significantly complicated in any theory of syllable structure that does not recognize the two major constituents onset and rime: a 'flat' theory of syllable structure like Kahn's (1976) or Clements' and Keyser's (1982) will have to collapse the three types of onset positions in which w can appear

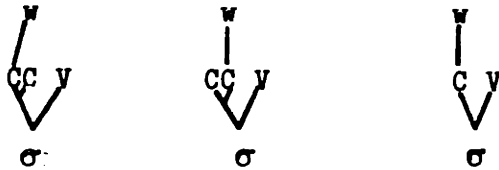

by writing the environment of the rule as in (5'):

(5') Onset w Deletion (in a theory without syllable internal structure)

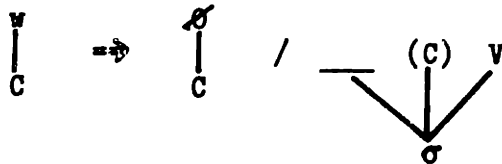

Let us first examine the CL effects in Ionic. Ingria's ENC or (1) appear irrelevant here since w vacates in ksenwos etc. an onset, not a rime position. Following this reasoning, Ingria (1980) suggests that w is lost in Ionic not postconsonantly but preconsonantly so that the immediate predecessor of ksēnos is ksēnos not

ksenwos. The rule responsible for the reconstructed forms like ksewnos is, according to Ingria, an Ionian extension of the panhellenic metathesis rule which produces moira 'fate' from IE*smorya, p^hainō 'seem' from *p^hanyō etc. We shall discuss the facts of metathesis below in section (4.2). What we need to note here is that if Ionian loses a preconsonantal w then all VwC sequences, not only the ones derived by metathesis, should become V̄C. This is clearly not the case in any Greek dialect. Ionian examples of VwC sequences are provided below. Note that (6.b) contains examples of heteromorphic Vw-C sequences, indicating that preconsonantal w fails to delete in derived and underived environments alike.

- (6) a. augē 'light of the sun', aulaks 'furrow', aulē 'court', eunē 'bed', keleuthos 'road', pleuron 'rib' etc.
- b. e-basileu-s-a 'I ruled', e-kau-s-a 'I burned', grāu-s 'old woman', thau-ma and thō-ma 'wonder', trau-ma and trō-ma 'wound', kheu-ma 'stream'.

A better solution to the problem of Ionian lengthening in ksēnos is one which relates the CL effects to the change in syllabification brought about by rule (5): if the input to (5) were, in Ionian, structures like ksen.wos then the loss of w must have been followed by resyllabification. CL would then be predicted.

The lack of CL in Attic could indicate, as Allen (1968) had pointed out, that the Cw clusters were tautosyllabic in this dialect at the time of the loss of w. The rime structure of kse.nwos could not have been affected by the change to kse.nos. This is why no lengthening took place.

Several considerations support this account of the difference between ksenos and ksēnos. We shall see in Chapter 4 that the tautosyllabic assignment of Cw clusters is a feature of Common Greek, probably inherited from IE. The possibility of such syllabifications is directly attested in the orthographic conventions of the Linear B syllabary script, in which any onset cluster $C_1 C_2 (C_3) V$ is rendered by inserting after each one of C_1 and C_2 a copy of the first vocalic sound belonging to the same syllable. Codas are, in general, not spelled out.

Thus, a word like Aleksandra, syllabified A.le.ksan.dra, is spelled A-re-ka-sa-da-ra with the ks and dr onset clusters spelled out and the coda n of ksan simply omitted. The Linear B spells most Cw clusters in full, sometimes using special signs for CwV sequences: this indicates the syllabification of the 2nd millennium ksenwos (ke-se-nu-wi-ja), odatwenta (o-da-tu-we-ta), wiswos (wi-so-wo) was kse.nwos, o.da.twen.ta, wi.swos. However, rw clusters are already spelled out in the manner in which coda-onset sequences are: thus, ko-wa, ko-wo stand for korwos, korwa ('boy', 'girl'; Att. koros, korē, Ion. kōros, kōrē and koros, korē), pa-we-a₂ stands for p^harwe^ha (pl. of 'cloak', Att. p^haros, Ion. p^hāros and p^haros) showing that the cluster was heterosyllabic. Thus Mycenaean, which belongs together with Attic-Ionic and Arcado-Cypriot, to the dialectal -ti- => -si- group (cf. Nagy 1970: 140), attests both the tautosyllabic assignment of Cw clusters necessary to explain the Attic facts and the beginnings of heterosyllabicity (Vr.wV) which was generalized in Ionian to all Cw sequences.

A look at the prosodic behavior of Cw clusters in the homeric

language provides a different argument for this analysis. The meter counts all consonant clusters, in the vast majority of cases, as heterosyllabic, in sharp contrast with the widely used possibility of tautosyllabic assignment attested in Attic for some stop-sonorant clusters (correptio Attica). That is a sequence $\check{V}CCV$ will have a metrically heavy, i.e., closed, first syllable regardless of the placement of morpheme and word boundaries. Although the homeric text transmitted by the tradition does not spell out the w's, their presence is metrically guaranteed:

- (7) esthlon d'ōte ti pō wēpes wepos, ōte telessas
you never announce or bring about good luck

(A 108)

The initial w of wēpes (spelled ēpes) prevents the shortening of the preceding ō by correptio epica (the shortening of a long vowel before another vowel). The initial w of wepos (spelled epos) creates a cluster together with the preceding s, which turns the short final e of wēpes into a heavy syllable.

- (8) ^hēmeterōi eni woikōi en Argeī tēlot^h i patrēs
in my house, in Argos, far away from (her) homeland

This is one out of about 2000 instances (Mazon 1942) where a restored etymological w explains the lack of elision between two apparently adjacent vowels (eni oikōi). More interestingly, word initial Cw clusters behave like other word initial CC clusters in turning a preceding short vowel into a heavy syllable:

(9) Aidoios te moi essi, p^hile h^hwekure, dwēnos te.

I am ashamed in front of you, father-in-law, and fearful

Here the initial dw cluster of dwēnos (spelled dēnos) turns the apparently unmetrical sequence re dē into the required spondee. The case of p^hile h^hwekure, which must be scanned ~~~~~, is slightly more complicated: h^hwekure, from underlying swekure becomes

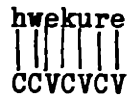

by a rule that we will analyze in Chapter 4. H then becomes an autosegmentalized feature of aspiration, thus

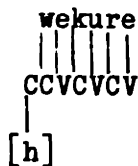

leaving behind the word initial C slot. The resulting structure behaves exactly like a word with an initial consonant cluster yielding in p^hile h^hwekure the syllabification

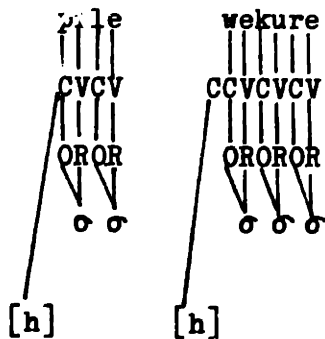

Consider now homeric forms spelled as gōnos ('knee-GENsg'), dōros ('oak-GENsg'), ōlos ('hale'), ksēnos, isos, dedimen, which are

all reconstructed as containing Cw internal clusters. We can tell that the Ionic long vowels are simply indicating here the heavy quantity of the initial syllable. In most instances<5> they do not reflect the original pronunciation of the language in which the poems were composed: since word initial Cw clusters must be posited there is no reason to believe that word internal Cw clusters had not been preserved. Thus we have in the syllabification implied by the homeric prosody the representations VC.wV required to explain the CL effects of OwD in early Ionian. In fact, the coexisting Ionic forms without CL (ksenos, stenos, derā, oros etc.) are matched by homeric forms like ǎnoito 'it may be finished' (S 473: cf. anetai ← anwetai elsewhere; the w appears in syllabic form in the related verb anuō 'to accomplish'); hēneka 'because' (A 110, etc.: cf. ēneka A 214, etc.); ēnate 'the ninth' (B 313 etc.: ēnatos B 295 etc.); kēna 'empty' (k 249: kēnos G 376 etc.); h^hupo-dēsate 'shrink in fear' (b 66 : cf. eddese A33, periddesantes Ps 822, whose geminate spellings represent the word-internal, morpheme initial dw clusters). Word initial Cw clusters are also found sometimes to fail to lengthen a preceding open, short syllable (Th 133, N 163, N 278 etc.). There is no need to assume that the variation between ksenos and ksēnos (= ksen.wos) in the homeric dialect represents an instance of dialect mixture, with the forms like ksenos being Atticisms. The homeric ksenos may stand for the alternative syllabification kse.nwos, which has yielded the Ionic forms without CL ksenos, stenos, oros, etc. On this point, one can agree entirely with Chantraine's judgment:

Ce flottement dépend de la coupe des syllabes et doit être rapproché de la double scansion pa-tros, pat-ros. Il n'y a lieu de voir dans les formes sans allongement ni des éolismes comme on l'a pensé, ni des atticismes (...), ni le traitement normal en ionien, mais une possibilité phonétique qui existait en ionien et dont les aèdes ont tiré parti suivant les besoins de la métrique.

(1942: 161, emphasis mine)

The key to this explanation of the difference between Attic ksēnos and Ionic ksēnos lies in the assumption that Attic had preserved a version of the Common Greek syllabification system (as represented by the Mycenaean spelling convention) for a longer time than Ionic did, and in particular that Cw clusters were obligatorily tautosyllabic when rule (5) entered Attic, but only optionally so in Ionic. That Attic was more conservative in its syllabification than Ionic is shown by the fact that the typically Attic tautosyllabic assignment of stop-sonorant clusters is closer to the Mycenaean principles of syllabification, according to which any sequence of consonants can be an onset if it is increasing in sonority<6>, than to the Ionian generally heterosyllabic assignment of all clusters.

3.2 The formal statement of CL effects and of Resyllabification

The preceding section has presented some of the evidence that compensatory lengthening is caused by the resyllabification of any consonantal segment in postnuclear position. As mentioned in section (1), this is the type of evidence that supports the view of the CL phenomenon behind (1) and its predecessor, the ENC. Before introducing the remaining Greek evidence for (1), I will turn to the

formal aspects of our results. I will begin by sketching an account of the interaction between Resyllabification and CL as stated in (1). I will then justify the formal details that set off (1) from conceivable alternatives, the ENC among them, and will explore the consequences of adopting (1) for the statement of resyllabification rules and for the analysis of onsetless syllables.

3.2.1 The interaction of Resyllabification and CL.

The statement of (1), repeated below, requires that an empty C slot in a rime be filled by association to the nuclear segment:

- (1) An empty C slot in the rime is associated with the segment in nuclear position. Formally,

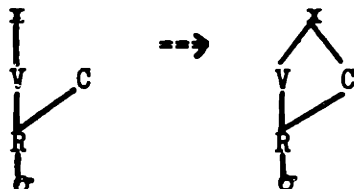

Consider now the output of the Onset w Deletion, rule (5), in a form like Ion. Isos:

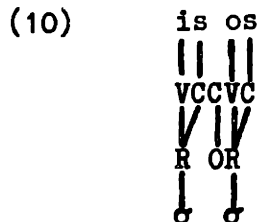

The empty onset C of the second syllable has been vacated by the deleted w. To the representation in (10) the resyllabification rule in (11) applies:

(11) Resyllabification 1

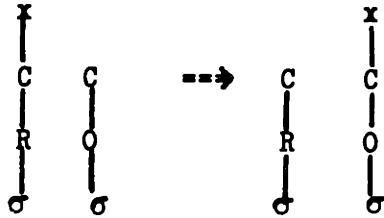

(11) associates the syllable final segment to the empty onset C, and disassociates it from its former skeleton position leaving behind a syllable final empty C. In a case like Ion. Isos, the output of Resyllabification 1 meets the specifications of condition (1), as can be observed below:

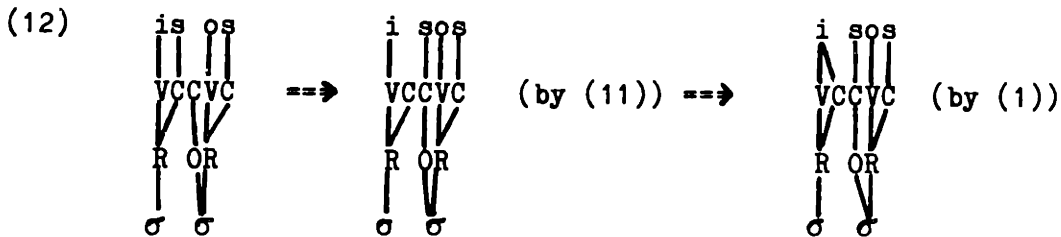

Two questions can be raised concerning a derivation like (12). First, the rule of resyllabification stated in (11) is a composite operation which includes an association and a disassociation step. It is fair to ask if simpler rules are also attested, which solve the problem of the onsetless syllable in one step, by reassociation only. We will see in section (4.2) that this is in fact the case.

Second, we know that resyllabification rules do not in general lead to CL. This is the case both across word boundaries and within words. An example of each type will have to suffice: in both the

Latin and the Greek prosody the syllabification indicated by the meter of phrase internal ...VC] [V... sequences, where the brackets indicate word boundaries, is

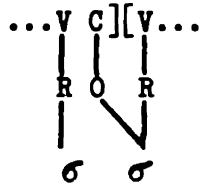

as in, for example, the first dactyl of the Iliad mēnin aēde 'sing the wrath', syllabified mē.ni.na (...). The resyllabification of word final codas indicated by the meter is obviously not accompanied by CL: had it been so, the resyllabified structures would be metrically equivalent to the non-resyllabified ones and in mēnin aēde we would be faced with the unmetrical sequence *mē.nī.na.ē.de.

A word internal example of resyllabification where no CL effects are observable is the case of cycle final V [liquid] w] sequences discussed in Steriade (1982). Briefly, alternations like those between Latin soluō and solūtus,

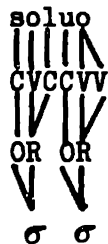

both on the root /solu/ 'to release', require that the first cycle syllabification





where the final glide is extrametrical, be changed to



before a consonant initial suffix like the participial -to- in solūtus. The change involves turning

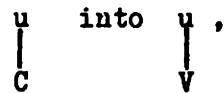

followed by the resyllabification of the rime final l:

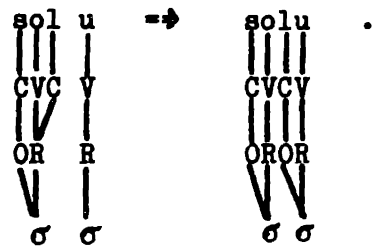

This instance of resyllabification is never accompanied by CL effects, a significant fact insofar as Latin attests CL in other cases<7>.

Before adopting (11), we need to explain why the predominant type of resyllabification is not accompanied by CL. Note first that

there is no difficulty in stating in autosegmental notation a resyllabification rule that will not feed condition (1):

(13) Resyllabification 2

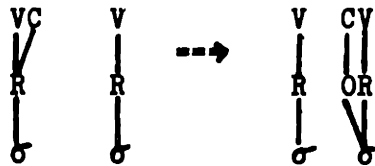

(13) is the formal equivalent of (11) on the skeleton tier: the rime final C is associated with the initial onsetless syllable and disassociated from the preceding syllable. Because, unlike in (11), the transfer affects a skeleton position rather than a segment, no empty C is left behind: this is why CL, as stated in (1) is not applicable in the output of such a rule.

Thus the question is not how to avoid predicting CL in the output of every resyllabification rule but rather how to explain the complementary distribution between a rule like (13), which applies in the across-word-boundary case and in cases like solūtus, and a rule like (11), which applies after Onset w Deletion.

The answer is rather simple: a rule like (11) is not applicable unless the 'onsetless' syllable begins with an empty C slot. This -- we must assume -- is not generally the case with onsetless syllables: structures like



(as in is.os after rule (5)) can only be the products of rules which, like rule (5), delete a segment at the beginning of a syllable. No such rules have applied in the two instances of resyllabification that are not followed by CL. Thus the simple juxtaposition of a closed syllable



and an onsetless syllable



will never feed a resyllabification rule like (11) and, for this reason, will never lead to CL. On the other hand, rule (13) is not applicable to the output of a segmental deletion like rule (5), since it requires a syllable beginning with a V slot rather than one beginning with an empty C slot.

It is also easy to see that the complementary applicability of the resyllabification rule which yields CL effects, (11), and of the one that does not, (13), is not stipulated by an arbitrary choice of formalization but rather explained by the autosegmental notation: a hypothetical rule of resyllabification which is applicable to the ...VC][V... case and which will lead to CL will have to be considerably more complex than (13):

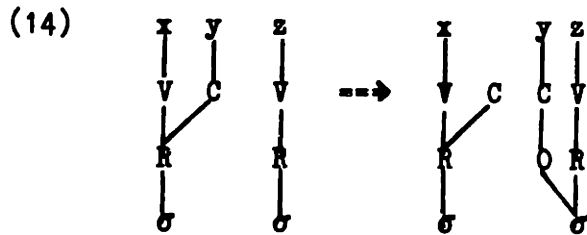

Note that (14) must include the insertion of a C-slot and the unrelated transfer of the syllable final segment y to the C inserted in syllable initial position. Similarly, a hypothetical rule of resyllabification applying to the output of a rule like Onset w Deletion and which will not lead to CL will have to be considerably more complex than (11):

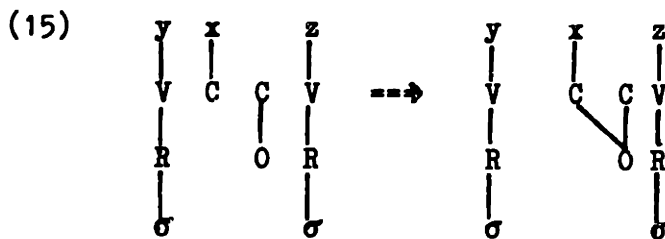

(15) must make the odd stipulation that the rime final C slot and its associated segment are transferred to the next syllable just in case that syllable begins with an empty C position.

It seems obvious now that in the absence of any data about CL one would choose (13) over (14) and (11) over (15). The simpler rules also turn out to predict the right interactions between resyllabification and (1), a clear indication that we are on the right track.

Note an interesting consequence of this explanation for why

only certain rules feed a resyllabification type that leads to CL: we must assume that there are two types of intermediate 'onsetless' syllables. The most frequent type, which is literally onsetless, lacks a syllable initial C. This type includes all morphemes or words that begin with a vowel. The less frequent type consists of a syllable beginning with an empty C slot and occurs only in the immediate output of segmental deletion rules like Onset w Deletion. If our analysis of the interaction between resyllabification and CL is correct, then we will have also shown that the representation of run-of-the-mill onsetless syllables may not include an empty syllable-initial C slot, and therefore, not an empty onset node at all<8>. This is a significant result since there is considerable temptation to explain the fact that resyllabification is obligatory when applicable by representing onsetless syllables as beginning with an empty node. Kaye and Lowenstamm (1981), for example, attribute the seemingly automatic character of resyllabification as applied to onsetless syllables to the requirement that empty nodes be eliminated whenever possible by resyllabification: their representation of all syllables lacking a segment in onset position includes an empty onset node, which resyllabification is supposed to eliminate. The syllabic representations they assume are not directly comparable to the ones adopted here because they lack a skeleton tier: but the argument made here extends to their skeleton-less format. If all syllables have an onset node, empty or not, how can we distinguish the output of Onset w Deletion in Ion. is.os, represented as

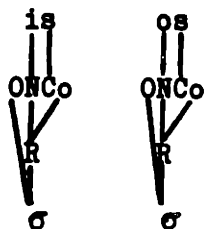

and a regular onsetless syllable?

3.2.2 CL, Degemination and Resyllabification

In this section I show that the statement of the CL mechanism must involve reference to an empty skeleton position, as the statement of (1) does. I contrast this analysis of CL with one in which the empty position to be filled by association to the nuclear segment is not a skeleton position but a non-terminal position in the rime template such as an empty Coda node. For the purposes of this argument I will discuss a particular class of theories of syllabic representation, those presented by Kaye and Lowenstamm (1981) and Selkirk (1982): these theories lack a skeleton, a tier mediating between segmental content and syllabic organization and must use non-terminal nodes in the syllable template, such as coda and nucleus, to do some of the work done by C's and V's in the format adopted here. Even though I will restrict myself to the discussion of such skeleton-less representations, my argument carries over to any statement of the CL mechanism that does not identify the empty position to be filled by CL as an empty C slot.

Consider the syllabic representation of an intermediate form like Attic ek^honsi (eventually ek^hōsi) 'they have' dictated by a skeleton-less theory of syllable structure:

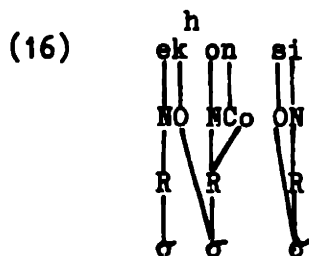

The nasal preceding s is deleted by a general rule of Greek, which I state below:

(17) n --> ∅ / ___ s

When applied to a form like ek^honsi, rule (17) yields an immediate output in which an empty Coda node figures:

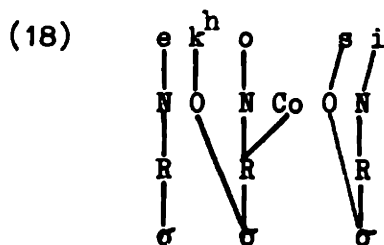

which suggests that a workable alternative to (1) in a skeleton-less format might be (19):

- (19) An empty Coda is associated with the segment in nuclear position.

What (1) achieves by mentioning an empty C slot (19) is meant to accomplish by mentioning a non-terminal node in the syllable template, the Coda. Otherwise (19) is remarkably similar to (1), which is what makes it interesting to discover that the two are empirically distinguishable. The facts that distinguish them are presented next.

3.2.2.1 Degemination

Attic is one of the Greek dialects in which geminate g's degeminate. I consider here three classes of derived geminate



clusters. The first type results from a series of processes discussed in Chapter 3, whereby a sequence of two coronal obstruents become a cluster that agrees in voice and aspiration<9> and whose first member is [+continuant]:

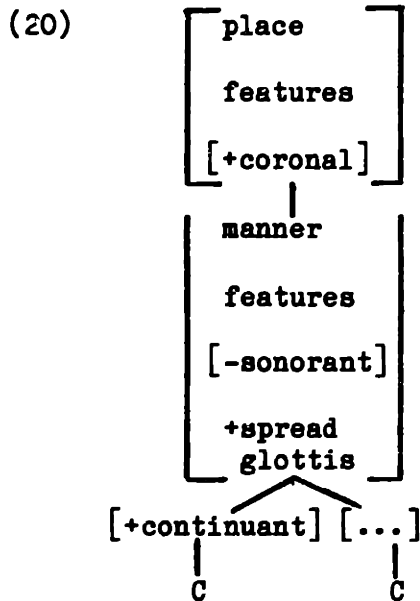

When the continuancy specifications of the linked matrices in (20) happen to be identical, the Shared Features Convention takes effect and creates a geminate g. This happens, for example, in the derivation of aorist forms on coronal final stems like dikad- 'to judge', komid- 'to provide', anut- 'to accomplish': the aorist suffix -g- preceded by the coronal stop undergo voicing and aspiration assimila-

tion and the stop becomes a continuant. The resulting structure,

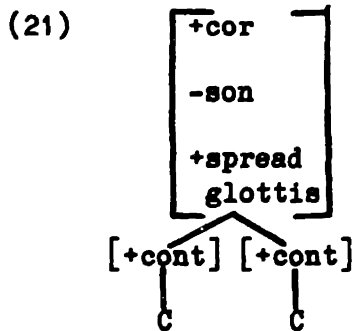

becomes a true geminate s by the Shared Features Convention:

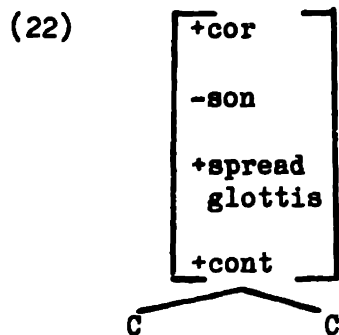

The geminate s of the coronal stem aorists are attested in the homeric dialect, where degemination is either non-existent as a rule or sporadic: edikassa, ekomissa, ānussa. In Attic the corresponding forms are edikasa, ekomisa, ānusa.

The second class of geminate s's results from a morphologically restricted rule, one of whose environments is represented by the Dative plural suffix -si: before -si a nasal stop assimilates entirely to s.

(23) Dative Plural Gemination

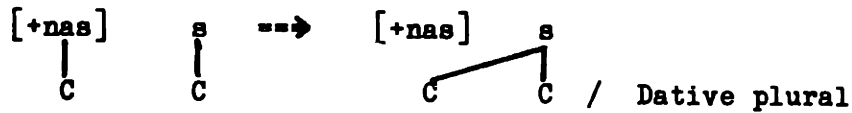

Thus the plural suffix of an n stem like poimen- 'shepherd' or daimon- 'deity' is poimesi from /poimen-si/ and daimosi from /daimon-si/: the steps here are (a) rule (23) and (b) the Attic degemination of s.

Note that we need to posit rule (23) in order to account for the contrast between daimosi and ek^hōsi from intermediate ek^honsi. In ek^honsi, because no geminate s has been created, n was deleted before s by rule (17). The result of this rule is, as usual, lengthening of the preceding vowel. The same derivation, if applied to /daimon-si/ would have produced *daimōsi<10>.

The third class of geminate s's arises at the boundary between the prefix sun 'with' and a verbal stem beginning with a consonantal sonorant or a continuant<11>: underlying /sun-rapt̄/ 'stitch together', /sun-rē/ 'flow together', /sun-lamban̄/ 'collect', /sun-leḡ/ 'gather', /sun-mak^hē/ 'be in alliance', /sun-mnem̄neū/ 'remember at the same time', /sun-sēm̄main̄/ 'signify one thing along with another', /sun-sītē/ 'have one's meals together with' and similar forms become surrapt̄, surrē, sullamban̄, sulleḡ, sunmak^hē, sumnem̄neū, sussēm̄main̄, sussītē.

(24) sun-Gemination<12>

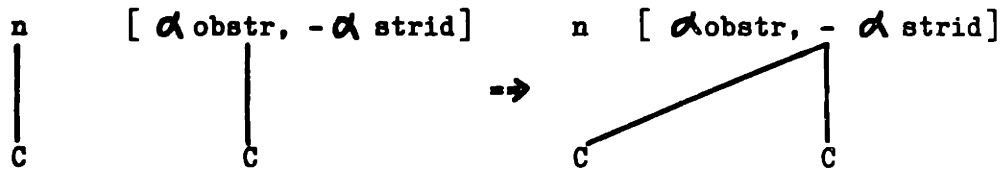

The geminate s resulting from (24) is simplified only in preconsonantal position: from underlying /sun-skeuazd̄/ 'pack up', /sun-spā/ 'contract', /sun-stoikheū/ 'stand in the same line' one obtains surface suskeuazd̄, suspā, sustoikheū. As in the preceding cases of degemination considered, the change of susskeuazd̄ etc. to suskeuazd̄ is not accompanied by CL<13>.

3.2.2.2 Why Degemination does not trigger CL in Greek

The significant fact introduced so far is that the rule of s-Degemination does not lead to CL. Nor do, according to the survey presented by DeChêne and Anderson (1979), most other rules of degemination: the failure of the Attic degemination rule to cause lengthening of the preceding vowel is thus not an isolated phenomenon. The autosegmental notation of true geminate clusters developed in Chapter 1 in conjunction with (1) as the formal statement of the CL mechanism can explain this fact. Note first that the autosegmental theory should allow two possible statements of a degemination process: the deletion of one of the skeleton positions associated with the branching segment, as in (25) and the disassociation of the branching segment from one of the skeleton positions it occupies, as in (26):

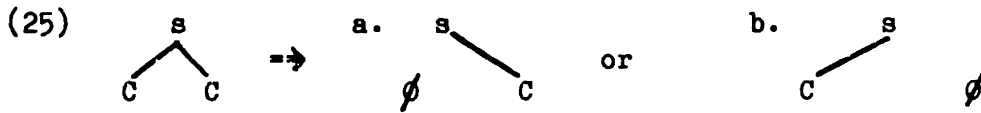

Let us consider first (25), as a possible degemination rule. Observe the interaction of (25) with (1) in the derivation of Attic posi 'feet-DAT' from underlying /pod-si/ through the geminate stage possi (attested as such in the homeric dialect):

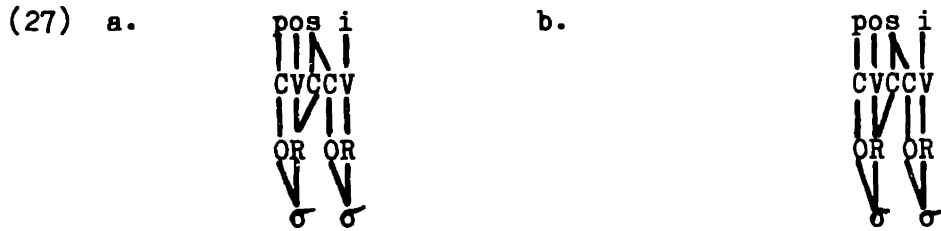

Degemination

(as in (25.a))

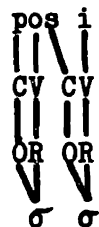

Degemination

(as in (25.b))



Resyllabification n/a

Resyllabification 2
 (as in (13))

CL (as in (1)) n/a

CL (as in (1)) n/a

Either version of (25) yields eventually a representation to which (1) is not applicable. Note in particular that (25) creates a sequence



which must be resyllabified by the removal of the rime-final C, (rule (13)), rather than by the removal of the rime final segment alone (rule (11)). Thus, whether or not this version of Degemination will feed resyllabification, it will not lead to CL.

3.2.2.3 Formulating CL without a skeleton

What we have seen so far is that two statements made available by the three-dimensional representations of the autosegmental theory, (25) and (1), permit an explanation for the lack of CL effects in the output of Degemination. We have also seen that the same theory of phonological representations predicts that Degemination may also sometimes be a rule to the output of which (1) is applicable: this is not a bad result, since at least one such case is in fact attested in Hindi, according to DeChêne and Anderson (1970 : 528). But the

essential point is that processes of Degemination that do not lead to CL can be explained. We can consider now what range of analyses is available within a skeleton-less format like Selkirk's or Kaye and Lowenstamm's for the interaction between Degemination and CL. Following the remarks made in Chapter 1 (page 71) on the representation of geminates in theories without a skeleton tier, I assume that the rule of Attic s- Degemination will have to take the form of (28):

(28) $\begin{array}{c} \text{s} \\ \wedge \\ \text{ } \end{array} \implies \begin{array}{c} \text{s} \\ | \\ \text{ } \end{array}$

The notation $\begin{array}{c} \text{s} \\ \wedge \\ \text{ } \end{array}$ indicates that s must be associated with two syllabic positions. The Degemination rule disassociates s from one of these positions. Consider now the interaction of one version of (28) with (19), the mechanism whereby a skeleton-less format will have to derive CL effects.

(29) $\begin{array}{c} \text{p} \quad \text{o} \quad \text{s} \quad \text{i} \\ | \quad | \quad | \quad | \\ \text{O} \quad \text{N} \quad \text{CoO} \quad \text{N} \\ | \quad | \quad | \quad | \\ \text{R} \quad \text{R} \quad \text{R} \quad \text{R} \\ | \quad | \\ \sigma \quad \sigma \end{array} \implies \begin{array}{c} \text{p} \quad \text{o} \quad \text{s} \quad \text{i} \\ | \quad | \quad | \quad | \\ \text{O} \quad \text{N} \quad \text{Co} \quad \text{ON} \\ | \quad | \quad | \quad | \\ \text{R} \quad \text{R} \quad \text{R} \quad \text{R} \\ | \quad | \\ \sigma \quad \sigma \end{array} \text{ (by (28)) } \implies * \begin{array}{c} \text{p} \quad \text{o} \quad \text{s} \quad \text{i} \\ | \quad | \quad | \quad | \\ \text{O} \quad \text{N} \quad \text{CoO} \quad \text{N} \\ | \quad | \quad | \quad | \\ \text{R} \quad \text{R} \quad \text{R} \quad \text{R} \\ | \quad | \\ \sigma \quad \sigma \end{array} \text{ (by (19))}$

What (29) shows is that if rule (28) erases the left association line between s and the syllabic tier, (19) becomes applicable and yields *p̄osi, an unwelcome result. If, on the other hand, (28) disassociates s from the Onset node by erasing the right association line, we obtain

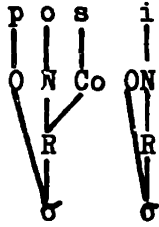

a representation which must be resyllabified. This is the point where our previous discussion of resyllabification types becomes relevant:

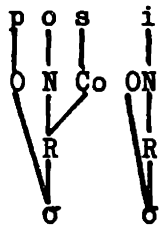

could be resyllabified in such a way that the conditions for CL will not arise, for example by stating resyllabification as the deletion of the coda node:

(30) Resyllabification 3

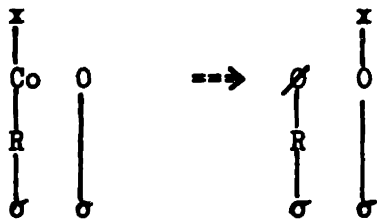

We know however that, as all other accounts, an analysis of CL based on (19) will also need a resyllabification rule which does lead to CL. That rule could be stated as in (31), where the empty Coda node resulting from the application of the rule qualifies its output for CL.

(31) Resyllabification 4

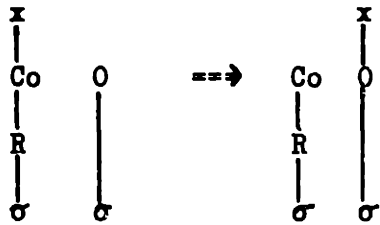

The problem lies not in the fact that necessary rules cannot be formulated. Rather, the difficulty is that the two necessary resyllabification rules apply to identical inputs:

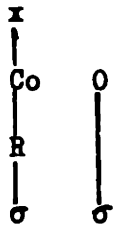

It is not possible to predict that the rule which will apply after Degemination is (30) rather than (31). It is also impossible to predict that (31), rather than (30), will apply to the output of Onset μ Deletion. The problem, I should stress, is not technical: rule ordering can solve the technical problems involved in deriving the correct Greek forms. The difference between the analysis of CL based on (1) and the one based on (19) is that the former predicts that deletions that affect a segment in syllable initial position will be accompanied by a resyllabification rule which leads to CL, whereas the latter predicts nothing<14>.

As we continue now our reanalysis of the CL phenomena in Greek, we will encounter another case in which this prediction made by (1)

turns out to be correct.

4. CL after g-Deletion

The main topic of this section is the analysis of CL effects in the Ionic-Attic forms where h is lost in postconsonantal position: underlying /V-angel-s-a/, for example, becomes historically āngel_ha and surfaces in Ionic-Attic as āngēla. I will begin by showing that the long vowels which surface in forms like āngēla after the loss of g can be analyzed as due to the application of Resyllabification 1, rule (11), which entails CL. I will then show that such an account is not only possible but necessary. A secondary theme of the section will be the characterization of the dialectal difference between the outcomes of h-loss in Lesbian and Thessalian, where it leads to the gemination of a neighboring consonant, and Attic, where it leads to CL.

4.1 The analysis

Syllable initial g became h in Common Greek, a rule we shall extensively justify in Chapter 4. The Common Greek syllable structure was such that any consonant sequence of increasing sonority qualified as an onset. S-sonorant sequences were thus among the onset clusters: accordingly, g underwent the change to h in words like esmi 'I am' (e.smi), selasnā 'moor:' (se.la.snā), sislawos 'propitious' (si.sla.wos) yielding later Attic ēmi, selānā, ^hīlaos, Lesbian-Thessalian emmi, selannā, illaos. The syllable structure of Greek changed drastically at the beginning of the first millenium BC: the class of onset clusters was reduced in Attic to a subset of stop-sonorant sequences, in other dialects probably to fewer clusters,

though the evidence is scant. No pre-consonantal s could occupy the onset initial position any more. This change in the syllabic structure of Greek must be in large part responsible for the fate of the s => h rule in historical times and in particular in Attic. First and foremost, the rule became cyclic and stopped applying in syllabically defined environments: intervocalic s and post-sonorant s occur in Attic morpheme internally, as in basileus 'king' or arsēn 'male' (later Attic arrēn). Second, it became, at least in Attic, a rule of s-deletion, as we shall see later in section (4.3). Third, it acquired morphological conditioning: for example the intervocalic s of the future and aorist morphemes are not deleted whereas most other s's that occur in pre-sonorant position as a result of suffixation will be subject to the rule<15>. The data illustrating the operation of s-Deletion in Attic is given in (32):

(32) a. neuter -es- stems

Nominative	Genitive	Dative	
/genos/	/genes-os/	genes-i/	'kind'
n/a	geneos	genei	by <u>s</u> -Deletion
	genōs		by contraction

b. comparative suffix -ios-

Accusative sg.	Nominative pl.	
/ple-ios-a/	/plei-os-es/	'more'
pleioa	pleioes	by s-Deletion
pleiō	pleiōs	by contraction

c. root final -s

present 1st sg.	aorist 1st.sg.	
/bus- \bar{q} /	/V-bus-t ^h \bar{q} -n/	'to stuff full of'
bu \bar{q}	n/a	by <u>s</u> -Deletion
bu \bar{q}	ebust ^h \bar{q} n	eventually
present 1st sg.	present 3rd sg.	
/es-mi/	/es-ti/	'to be'
\bar{e} mi	n/a	by <u>s</u> -Deletion and CL
\bar{e} mi	esti	eventually

d. s-aorist of sonorant final roots

/V- men-s-a/	'I remained'
em \bar{e} na	by <u>s</u> -Deletion and CL

e. s-initial suffixes

/V-lip-e-so/	'I left for myself'
elipeo	by <u>s</u> -Deletion
elip \bar{o}	by contraction

The facts of (32) can be covered by rule (33). I omit mention of the morphological environments to which (33) does not apply.

(33) s-Deletion

$s \rightarrow \emptyset / [+sonorant] ___ [+sonorant]$

The class of forms we are interested in is (32.d): here s is lost in

postconsonantal position yet, as in the case of preconsonantal s-loss, esmi => ēmi, we observe the effects of CL.

The analysis I propose for these forms is identical to the one defended in section (3.1) for the CL effects in Ion. kōros from kor.wos. S is deleted in emensa in syllable initial position, it leaves an empty C slot behind and the resulting configuration triggers the resyllabification rule (11) which leads to CL.

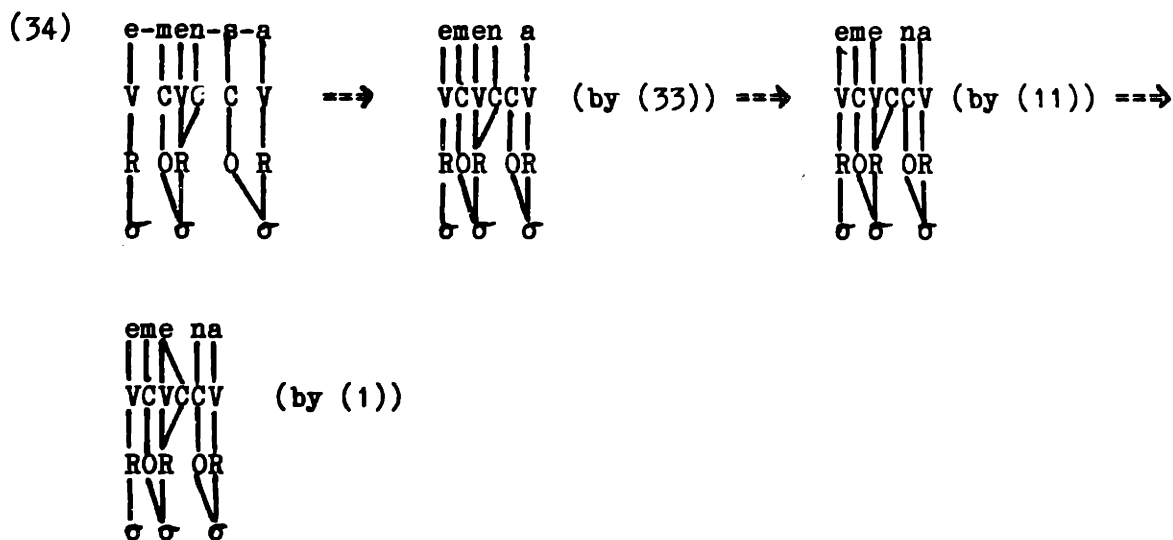

Recall that this is intended as a synchronic Attic account of the g/∅ alternations attested in that dialect. It departs in two related respects from what has become, since Kiparsky's study of sonorant clusters in Greek (1967), the standard analysis of the CL in emēna and related forms: the account sketched in (33) assumes a direct g => ∅ rule, rather than an intermediate h stage for g; and it omits the metathesis between g (or h) and the preceding sonorant postulated by Kiparsky.

4.2 Sonorant -h metathesis

According to Kiparsky, all sonorant -h sequences of Common Greek were metathesized to h- sonorant as part of a more general metathesis process which included the change of sonorant -y to y-sonorant in forms like morya \rightarrow moira. Since the postconsonantal -prevocalic change of s to h is attested only after sonorants, it is possible to consider all such h's as eligible for Kiparsky's generalized metathesis rule. Thus emenha would have become emehna by metathesis, after which the coda h lost segmental status leading to CL in Ionic-Attic and gemination in Aeolic. The idea of sonorant -h metathesis is attractive because it promises to allow a maximally simple statement of the difference between Attic-Ionic CL and Lesbian-Thessalian gemination. The Aeolic geminates correspond to the Ionic-Attic vowel length both in items that lost h in preconsonantal position (cf. Lesbian emmi, corresponding to Ion.-Att. ēmi from /es-mi/) and in items that lost h in post consonantal position (Lesb.-Thess. emenna corresponds to Ion.-Att. emēna). Kiparsky's metathesis hypothesis will account for this fact: a metathesized vowel-h-sonorant sequence, like an underlying one, will undergo loss or autosegmentalization of h followed by CL or gemination depending on the dialect. One may assume that the Aeolic gemination was a language specific rule stateable as in (35). If so, Ionic-Attic differs from Lesbian-Thessalian in only one respect: the former lacks the gemination rule.

(35)

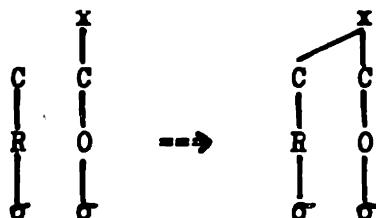

It seems that the analysis proposed in the preceding section for the loss of postconsonantal s in Attic cannot provide an equally satisfying account of the difference between Attic-Ionic CL and Aeolic gemination. We will have to assume that Aeolic differs from Attic in two respects: it has rule (35), which Attic lacks, and it treats the sequence



the input in Attic to rule (11), by linking empty onset C to the preceding consonantal segment:

(36) Aeolic resyllabification

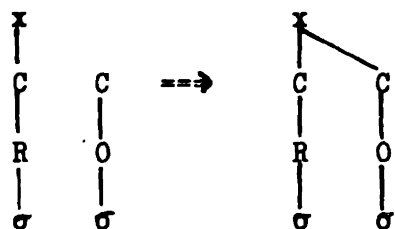

Rule (36), the mirror image of the other Aeolic source of geminates, (35), will derive emenna, whether or not we assume an intermediate stage h for the disappearing s:

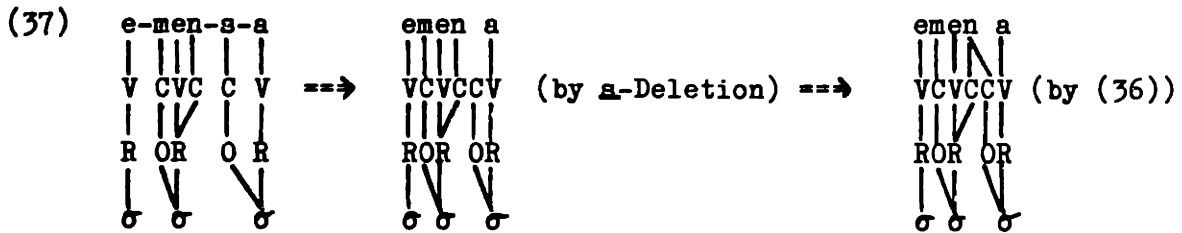

The only defense for adopting the more complex analysis based on CL-from-resyllabification over CL-from-metathesis would be to show that the additional rule required by the former, rule (36), is independently needed. This is in fact the case: (36) applies in the case of the loss of postconsonantal w in Aeolic, yielding the expected geminates. Aeolisms like gonna 'knees' (/gonw-a/ syllabified gon.wa), ksennoi 'foreigners' (ksen.woi before the loss of w), enneka 'because' (en.wa.ka), perras 'limit' (per.was), stennos 'narrow' (sten.wos), derrā 'neck' (der.wā) are cited by grammarians (in Thumb 1909:240, Meister 1882:145). Thessalian inscriptions give proksenniān, proksenniōn (Thumb 1909:240) and a Lesbian inscription attests isso-theoisi (is.wo-) 'equal to the gods-DATpl' (Meister 1882:134). Kallistos (kal.wis.tos) appears in Alkaios 108, perratōn in Alkaios 84<16> ennosi-gaios 'Earth shaker' (en-wosi... on the root woth of ōtheō 'to thrust') is cited by a commentator to Hesiod (Meister 1882:143) as an Aeolic version of the epic first member of compound spelled variously as ēnosi- (ēnosi-phullos 'with quivering foliage'), enosi- (enosi-kthōn 'Earth-shaker') and ennosi- (ennosi-gaios). (We recognize in the first two spellings the alternative syllabifications en.wo.si, e.nwo.si discussed above, page 124).

Such forms were dismissed by Buck (1973) and others as

"hyperaeolisms", presumably because the lack of gemination is also attested: kora (Sappho 52,4; Alkaios 14), eneka, enatos (Lesbian inscriptions cited in Thumb 1909:258), kalos (Sappho 27,79,101), gona (Alkaios 39). However, sporadic degemination is attested throughout the Aeolic territory for clusters of all origins, including h-sonorant, sonorant-h sequences, whose geminate treatment in Aeolic had never been in doubt. Meister summarizes the facts aptly: "Die einer Liquida benachbarten Spiranten werden in Aeol. der Liquida assimiliert. Die dadurch entstandene Geminatbildung des Liquida findet sich in der Schreibung nicht selten vereinfacht." (Meister 1882:137)<17>.

Thus, gonna, proksenniōn etc., are genuine representatives of the geminate outcome of postconsonantal w in Thessalian and Lesbian. The unmarked option of providing an empty onset C with segmental content by association to a preceding segment is instantiated in these Aeolic forms.

We have shown in this section that a rule of resyllabification like (36) is needed in Aeolic, independently of the analysis of g-loss. Given the need for (36), simplicity considerations no longer rule in favor of the metathesis theory: on either account one out of the three classes of Aeolic geminates (ksennos, emmi, emenna from Cw, h-sonorant, sonorant-h original clusters) must be derived by a separate rule.

In the next section we examine the direct evidence available in Greek for the displacement of h and conclude that the metathesis analysis should be abandoned for synchronic Attic as well as for Common Greek.

4.3 The autosegment h

The word and phrase internal sandhi facts from Attic which I list below show that h must be associated to a segment in syllable initial position:

- (38) a. kai ^hateros 'and the other' ==> k ^hateros
- ^hep̄ta-^hēmeros 'of seven days' ==> ^hep̄t̄ ^hēmeros
- nukta ^holēn 'night-ACCsg. whole-ACCsg.' ==> nuk̄t̄ ^holēn
- to ^himation 'the garment' ==> t̄ ^hoimation
- tetra ^hippos 'driving four horses' ==> tet̄ ^hrippos
- pro- ^hodos 'entrance' ==> p̄ ^hrōdos

The structure of an h-initial form like ^hippos is indicated below:

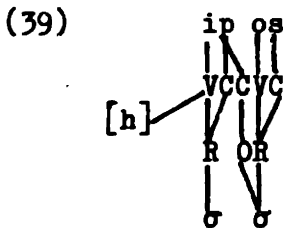

h is not a segment in the sense that it does not take up a skeleton position by itself. Had ^hippos begun with a C slot it would not behave as a vowel initial word with respect to resyllabification, contraction and elision: it would not allow contraction or elision, the two rules eliminating one of two adjacent nuclei that have applied in (38), and it would block the resyllabification rule (13) from applying

in phrases like dōmasin hēmeterois, scanned $\sim\sim/\sim\sim/ \sim$ (in Aristophanes Peace 115) because syllabified

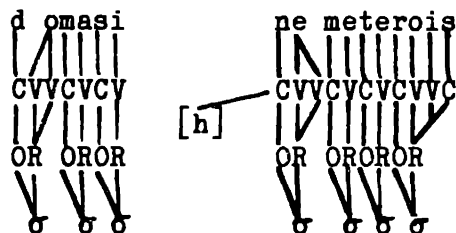

after the application of (13). Given the need for representations like (39) we must assume that h is an incompletely specified matrix, having values for manner features alone or for just [spread glottis]. We can attribute the fact that it does not have an associated position on the skeleton to the fact that it is not a complete segment: the hypothesis would be that melodic units lacking one of the major components of a segmental matrix, the place or the manner features component, may not take up a skeleton position, though they may be associated to one, if a "real" segment also is.

We may turn now to the facts in (38): let us consider first forms like p^hrōdos, t^hoimation and tet^hrippos, in which h seems to have been metathesized with the preceding sonorant. These forms, like all in (38), result from either one of two rules that eliminate one of two adjacent nuclei. Contraction, the rule deriving the long nucleus of p^hrōdos, t^hoimation can be stated in simplified form as in (40):

(40) Contraction

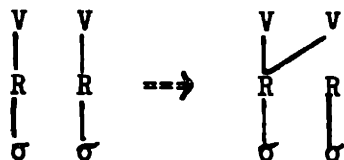

The segments associated with the two V's that become tautosyllabic in the output of (40) undergo a complex set of assimilation rules that will be ignored here. The result of Contraction is transparently reflected in t^hoimation, whose syllabic structure is

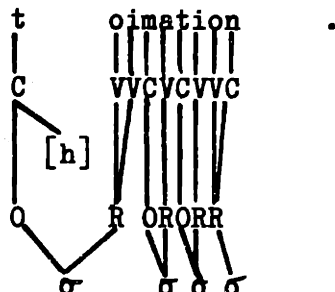

Elision, the other rime reduction rule that applies in (38), eliminates not only the first of two adjacent rimes but also the V's associated with it: the result of Elision are forms like tet^hrippos, k^ha-teros, nuk^ht^holen. Elision is stated below:

(41) Elision

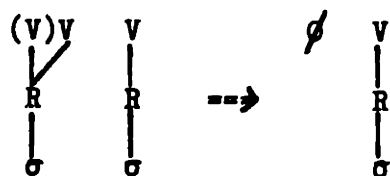

I assume that the rime and syllable node associated with the deleted nucleus are pruned automatically.

Elision will be followed by the reassociation of the onsets left stray after the elimination of the first syllable. This step is shown below:

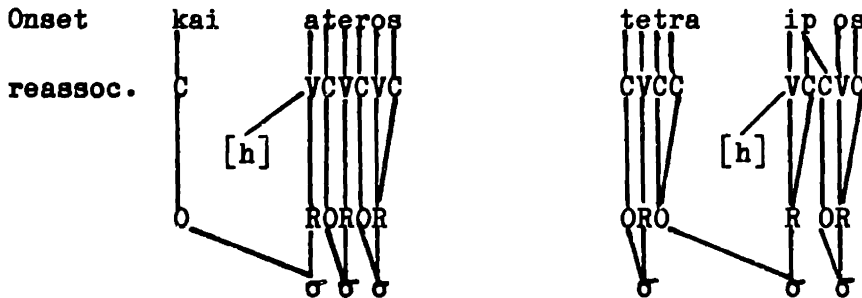
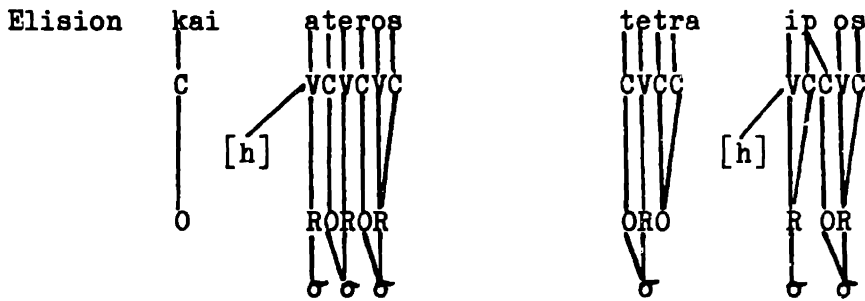
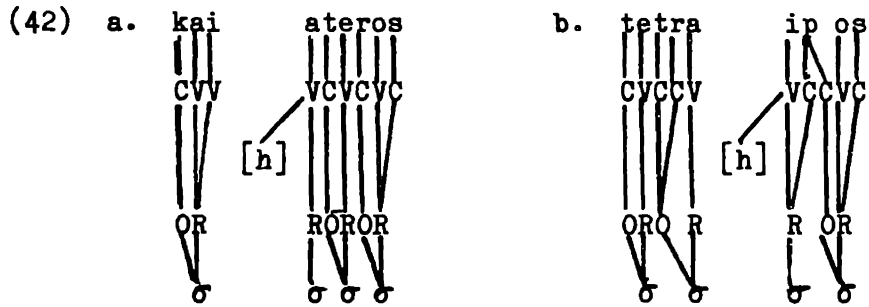

Note that the constituent structure of the syllable part left intact by Elision is not affected: in tet^hrippos the syllable whose rime was deleted by Elision had a branching onset (tr). That piece of structure is carried intact into the new syllable created by Onset Reassociation, a rule stated below:

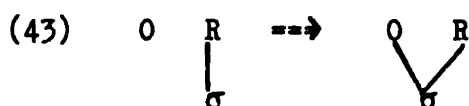

To turn the output of Onset Reassociation or of Contraction into the surface forms k^hateros, tet^hrippos, p^hrōdos, we need to reassociate [h], which finds itself in syllable medial position, with the syllable initial skeleton slot. The necessary rule is not a metathesis process: in forms like p^hrōdos, that is

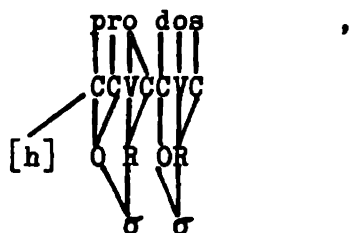

h has skipped over two skeleton positions before reaching the syllable initial p. Accordingly, I state it as the reassociation of h to the syllable initial skeleton slot. Note that the formulation of the rule makes crucial use of the assumption, unjustified until now, that h occupies a distinct tier of the phonological representation:

(44) h-Reassociation

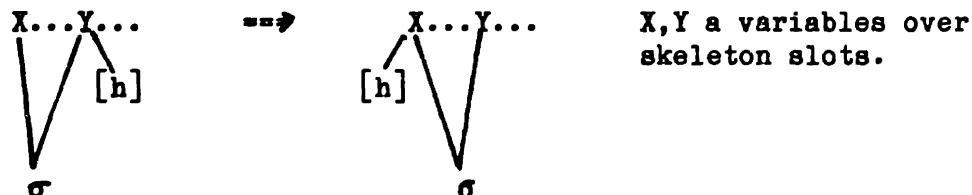

The reassociated h will now be in a position to trigger aspiration assimilation in forms like nuk^h t^holēn, ep^h t^hēmeros from intermediate (post rule (44)) forms

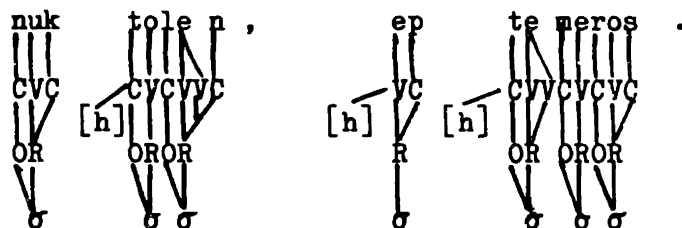

We will see the relevance of rule (44) to the statement of aspiration assimilation in the next chapter.

We have motivated so far one rule of h-displacement, rule (44), which must apply in the synchronic phonology of Attic. This is not the metathesis rule hypothesized by Kiparsky: it specifies that the landing site of h is syllable initial position no matter where in the syllable h originates; it applies within one syllable only rather than across syllables (otherwise we would get not only k^hateros but also *k^haiateros); it displaces a melodic unit that has no independent skeleton position and does not acquire one.

Suppose now that the rule affecting inter-sonorant s's in Attic was a rule changing s to h and suppose that the metathesis rule required by Kiparsky's hypothesis also operates in Attic. The latter will have to operate before h loses segmental status since its output will have to be forms like

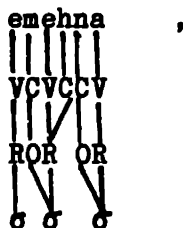

in which the loss or displacement of h must leave behind an empty

position in the rime. The necessary order of operations would therefore be: (a) sonorant-h sequences are metathesized to h-sonorant; (b) h loses segment status and becomes an autosegmentalized features of aspiration; (c) h-Reassociation applies. Consider now a derivation of espēra 'sow-aor.-1st sg.' from /V-sper-s-a/:

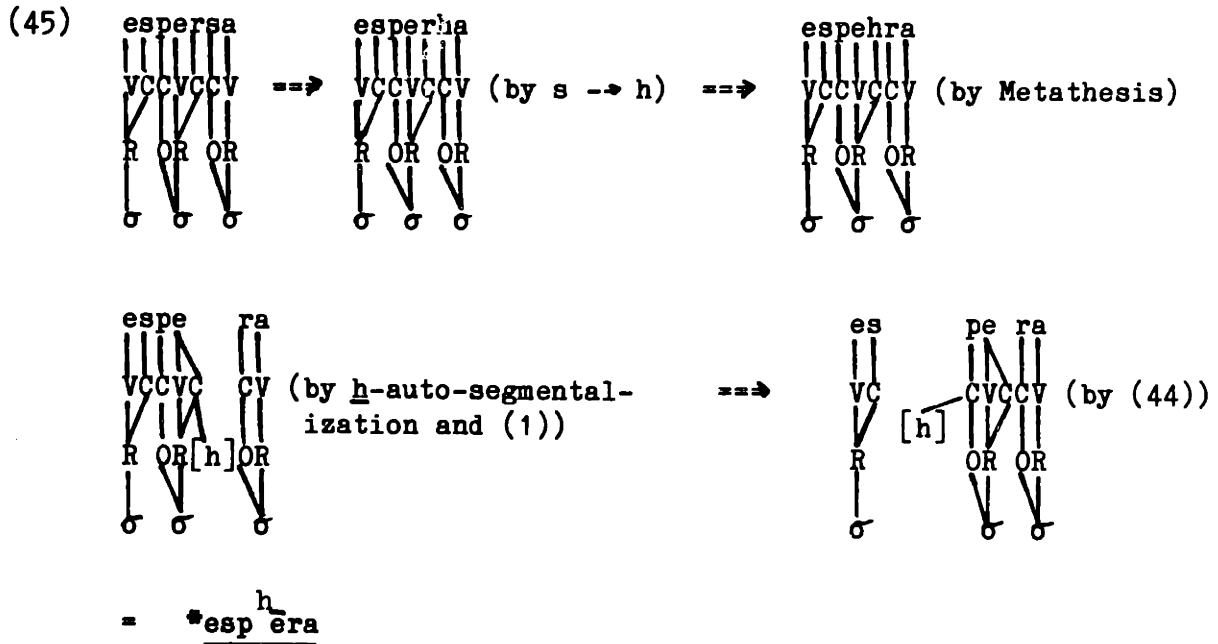

with the initial stop of the second syllable. By the rules motivated above a tautosyllabic h should turn a syllable initial stop into an aspirated stop (as in t^hoimaton, p^hrōdos). No difficulty arises if we omit Metathesis from the derivation and attribute CL to the effects of the Resyllabification rule (11). One must conclude then that there is no rule of Metathesis in the synchronic grammar of Attic (and, to the extent that the facts of (38) are panhellenic, in the grammar of any historical Greek dialect). Consequently, the facts concerning CL in the sigmatic aorists of sonorant-final stems are to be derived by resyllabification.

The analysis of h-Reassociation motivated here also gives the reason why in the synchronic grammar of Attic the rule eliminating s between sonorants must not derive an intermediate h-stage. To see this consider the derivation of the genitive of an s stem like etos 'year', /etes-os/:

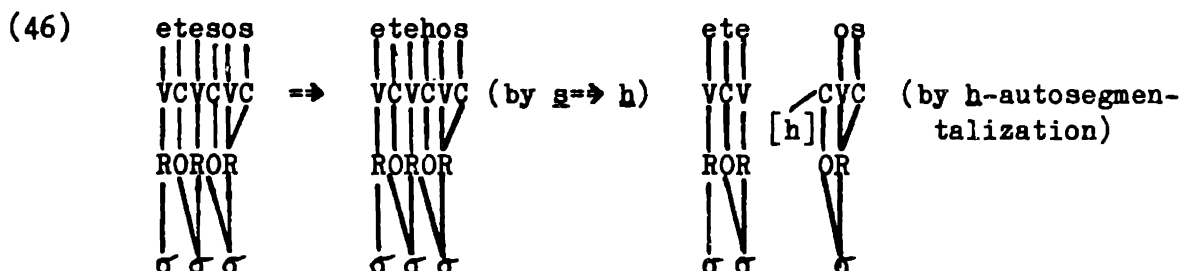

The C left empty by the autosegmentalization of h will have to delete in order to allow Contraction to apply in such forms. Contraction will however create the conditions for h-Reassociation, whose result will be *et^hos, an incorrect form: the correct output is et^hos:

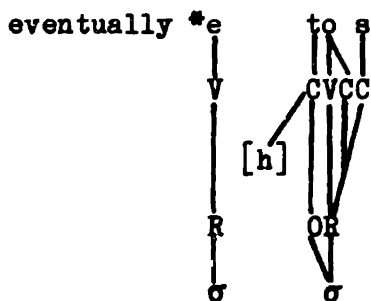
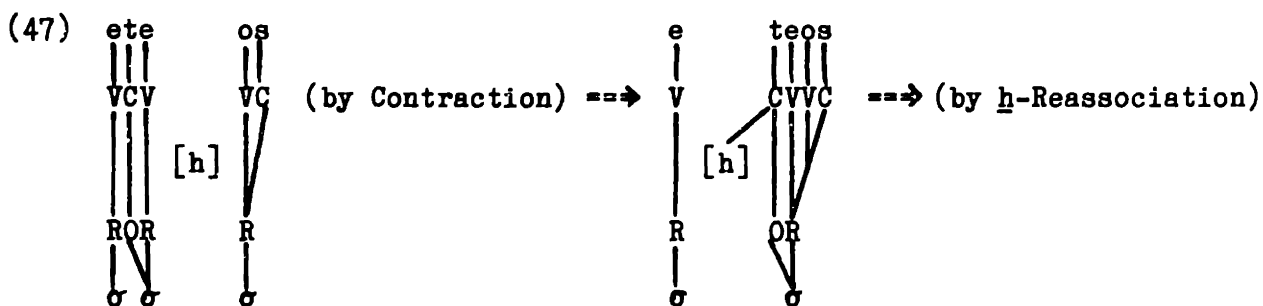

Before concluding let us try to determine whether the h-sonorant metathesis could be a fact of Common Greek, even though Attic lost the corresponding rule.

We know that the aspiration resulting from s landed outside of its own syllable in prehistoric Greek. Lejeune (1972: 95) gives the following rule: "la spirante h issue de *-s- entre voyelles s'est souvent reportée devant la première des deux voyelles si celle-ci était initiale de mot." The clearest examples are:

- (48) $ews\bar{\sigma}$ 'burn' $\implies eu^h\bar{\sigma}$ $\implies h\bar{eu}\bar{\sigma}$
 $iseros$ 'holy' $\implies i^h\bar{e}ros$ $\implies h\bar{i}eros$

In preconsonantal position the aspiration resulting from s appears, again, frequently on the initial vowel:

- (49) $\bar{e}sm\bar{a}i$ 'I sit' $\implies \bar{e}^h\bar{m}ai$ $\implies h\bar{e}m\bar{a}i$
 $wesnumi$ 'I wear' $\implies we^h\bar{n}umi$ $\implies w^h\bar{e}nnumi$ $\implies h\bar{e}nnumi$

The examples below are cited as illustrating an h migrating from postconsonantal position to the initial vowel:

- (50) $ansi\bar{a}$ 'rein' $\implies h\bar{e}ni\bar{a}$ (epic)
 $\bar{a}ws\bar{\sigma}s$ 'dawn' $\implies \bar{a}w^h\bar{\sigma}s$ $\implies h\bar{a}\bar{\sigma}s$ $\implies h\bar{e}\bar{\sigma}s$ (Ion., epic)
 $arsma$ 'fitting' $\implies ar^h\bar{m}a$ $\implies h\bar{a}rma$

It seems clear that h, when separated from the word initial by only one nucleus was occasionally "metathesized" (in a loose, non-

technical sense) with that nucleus as in $\overset{h}{i} \text{eros} \Rightarrow \overset{h}{i} \text{eros}$ and $\overset{h}{\xi} \text{mai} \Rightarrow \overset{h}{\xi} \text{mai}$. The rule should be formulated to metathesize an entire rime of the form

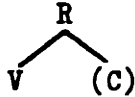

with a following \underline{h} . We may choose to state it as a variant on \underline{h} -Reassociation, assuming that, as in historical Greek, the prehistoric displacement of \underline{h} affected a floating segment:

- (51) Attach \underline{h} to the vowel of an immediately preceding constituent.

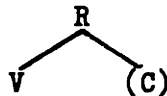

But whichever formalization we select, one consequence must be shared by any statement: \underline{h} lands in pre-nuclear position. Its displacement and later loss of segmental status cannot lead directly to CL. For pre-historic Greek too, CL effects in $\overset{h}{\xi} \text{niā}$, emēna etc. must be attributed to resyllabification, not to metathesis<18>.

5. Conclusion

We have seen that the conditions for compensatory lengthening are created in Greek not only by a rule which deletes a segment in coda position but also by rules which remove a coda segment from the syllable final C and resyllabify it. The resyllabified segment may be a sonorant, as in

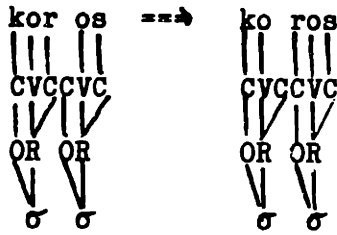

or an obstruent as in

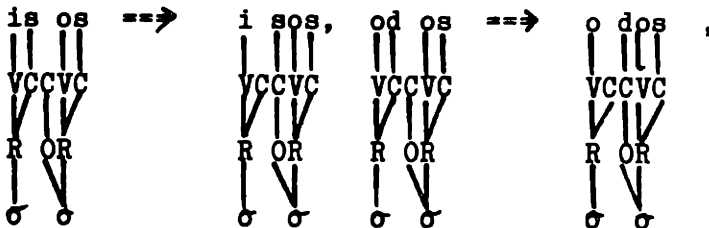

the Ionic outputs of Onset w Deletion. Compensatory lengthening is observed in both cases. The same type of derivation has been shown to be necessary for an account of postconsonantal s- loss in the Attic and Ionic paradigms of the sigmatic aorist of sonorant stems. The statement of (1) as the mechanism of CL in Greek was thus defended<19>.

By investigating interaction of (1) and resyllabification we have also reached the conclusion that there exist two types of onsetless syllables, and that each will acquire an onset segment by a different type of resyllabification rule. We have seen that a three-dimensional framework which includes a skeleton tier, can represent the difference between the two types of onsetless syllables and predict which rules derive what type.

I have left implicit so far a consequence of this analysis which concerns the representation of the surface tense: lax distinction

exhibited by Attic mid long vowels. Attic distinguishes between lax mid long vowels (as in $\overset{h}{\underline{on}}$ 'whose -pl. masc.', $\overset{h}{\underline{on}}$ 'whom-sg.fem') and tense mid long vowels (as in \underline{on} 'therefore', \underline{e} 'if'). In such forms the distinction must be considered underlying. Derived tense vowels are created by the operation of (1), as in $\overset{h}{\underline{es}}$ (from $\overset{h}{\underline{ens}}$) 'one', $\overset{h}{\underline{os}}$ 'whom-pl.masc.' (from $\overset{h}{\underline{ons}}$) as well as by certain contraction types. Since we have established that the long vowels resulting from (1) have the structure

(52)



we may suggest that their tenseness is simply the phonetic interpretation of the fact that they are linked to a VC sequence. This implies that all tense vowels of Attic have the structure of (52) and, by elimination, requires lax vowels to have the structure:

(53)



There is in fact independent support for (53) as the representation of lax vowels in Attic, and thus indirectly for (52) as the structure of tense vowels. This comes from the analysis of the augment (part of the morphology of imperfect and aorist) and of the perfect reduplication. We will see in the next chapter that the reduplicating syllable in the perfect consists of a CV prefix with no associated segmental melody. The V slot will be associated to a root segment when the verb root begins with a vowel, as in the case of $\overset{h}{\underline{op}} \overset{h}{\underline{elēka}}$,

the perfect of $\bar{q}p \bar{e}l\bar{q}^h$ 'I owe':

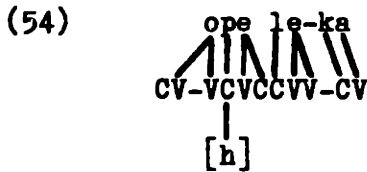

The result is a lax long mid vowel. We obtain the same result in the augmented forms of the imperfect and aorist of vowel initial roots. I assume that the augment is a segmentally empty V prefix:

(55) a. $\bar{e}st^h ion$ 'eat-imperfect-1st.sg.' (present $\bar{e}st^h i\bar{o}$)

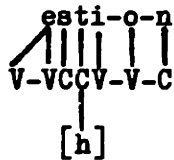

b. $\bar{a}t^h el\bar{a}sa$ 'want-aorist-1st.sg.' (present $\bar{a}t^h el\bar{a}$)

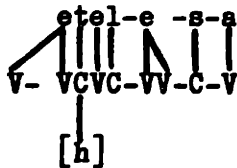

The long lax vowels of the perfect, imperfect and aorist must be attributed to the prefixation of a V slot to the already existing initial V of the root skeleton: there is simply no other way to characterize the length/laxness distinction between augmented and unaugmented forms. Thus the need to represent lax vowels as VV sequences is established independently.

By eliminating the tense: lax distinction from the underlying phonological inventory of Attic we can explain why it is manifested on

the surface only by long vowels: short vowels are, by definition linked to a single skeleton position<20>.

Finally, if we take seriously the idea that all long vowels resulting from CL must be VC units, we may be able to explain why certain languages like Finnish, while displaying vowel length contrasts, do not exhibit any CL effects.<21> The reason might be that some languages do not permit vocalic segments to be linked to C slots: Finnish might be such a language. This hypothesis opens up the possibility that CL is indeed a universal phenomenon, pace apparent counterexamples like Finnish.

Chapter 2 - Footnotes

1. I will not discuss here, for lack of relevant evidence, the status of (1) as a convention rather than as a rule. The fact that CL effects are encountered with remarkable regularity in many languages might suggest that the mechanism that gives rise to them is a universal convention. On the other hand, there are testable differences between the ways a rule and a convention operate: one would expect a convention to take effect whenever its environment is met, in contrast with a rule, whose applications are limited to once-every-cycle. Before such evidence becomes available the issue must be left open.

2. DeChêne and Anderson note that the intermediate development of the nasal before a into a glide is attested in Aeolic, where the glide, y, corresponds to the Ionic-Attic vowel length in forms like ek^h oisi (Ion.-Att. ek^h ōsi) from underlying /ek^h-o-nti/ 'they have'; pais (Ion.-Att. pās) from underlying /pant-s/ 'all'; tois nomois (Ion.-Att. tōs nomōs) from underlying /t-o-ns nom-o-ns/ 'the laws-ACC'. (The change from /ek^honti/ and /pant-s/ to intermediate ek^h onsi, pans is due to separate processes). We should, however, note that if the monophthongization theory were to be seriously pursued, the Aeolic glides in ek^h oisi, tois nomois etc., could not serve as models for the glides that must be hypothesized for Ionic-Attic. N could not have become a glide like y or w in Ionic-Attic since in cases like /pant-s/ the change of n to either y or w will yield *pais or *paus, forms which cannot be corrected into the attested pās by any stateable rule. Thus, in order to account for the CL effects in Ion.-Att. ek^h ōsi, pās, tōs nomōs the monophthongization theory will have to posit either

unattested types of glides that can be later contracted with the preceding vowel or a direct contraction of the vowel-nasal sequence into a long vowel.

3. Clements (1978 and 1982) and Sezer (1982) argue for such conventions on the basis of data from Luganda and Turkish.

4. On the assimilation of w to a neighboring nonsyllabic sonorant see Kiparsky 1967. On the evolution of the kw,tw clusters see Lejeune 1972: 80, 182).

5. There do exist cases in which the restoration of an etymological w will be disallowed by the meter (cf. Chantraine 1942: 116; Parry 1934) and the existence of such cases opens up the possibility that genuine forms of a w-less dialect were also part of the original text.

6. More on this in Chapter 4.

7. A clear example of CL effects in Latin is the following: before a continuant, s or f, the sequence vowel-nasal becomes a long vowel, nasalized or not depending on the dialect or historical stage of Latin. The rule is almost identical to that of Greek $n \Rightarrow \emptyset / \underline{\quad} s$, the only difference being that the intermediate stage of the nasalized vowels is recorded by the classical Latin orthography. Thus classical spellings like cōnsul must have stood for [kō̃sul] or denasalized [kosul], as the archaic, but more sincere spelling cōsul indicates. The Romance languages inherited long denasalized vowels from the word internal sequences vowel-nasal-continuant.

8. Recall that we assume the labels Onset and Rime to have no reality independently of the existence in the syllable of a left or right branch. Thus, if there is no syllable initial C-slot, there is no left branch and, by definition, no onset node.

9. Voice, irrelevant here, will be ignored (see Chapter 3, section 5.5.3).

10. Note that stems ending in -nt like geront- 'old man', elep^hant- 'elephant', luont- 'loosen-pres.part.' have regular dative plurals like gerōsi, elep^hāsi, luōsi, since rule (23) yields geronssi, elep^hanssi, luonssi, degemination reduces the nss sequence to ns, and n is dropped before s, with CL as in ens ⇒ ēs, etc. The long stem-final vowels of gerōsi, elephāsi, luōsi tell us that the dative plurals of nasal stem endings are not exceptions to CL: rather, they are subject to rule (23), which is followed by Degemination, which never gives rise to CL.

11. The class of segments to which (24) applies is more simply stateable as: segments equal to or higher than s on the sonority scale. I note that vowels, in particular high vowels, cannot occupy non-nuclear positions in Greek, which excludes them independently from the structural description of (24).

12. A more restricted version of (24), to which only stems beginning in l, n, m and sometimes r are subject, applies after the prefix en 'in': /en-lemma/ 'defect', /en-menō̄/ 'abide in', /en-raptō̄/ 'sew up in' become ellemma, emmenō̄, erraptō̄ though forms like enraptō̄ are also found.

13. An alternative interpretation of these facts is that g cannot be syllabified in inter-obstruent position -- a fact we will establish in the next chapter -- and, as a result, is eliminated not through Degemination but through the convention providing for the erasure of stray segments and skeleton slots. If so, the lack of CL effects in the output of the simplification of susskeuazdō to suskeuazdō will not be significant. The reason why I attribute the cluster simplification in suskeuazdō to a restricted version of Degemination is that a cycle initial unsyllabified consonant, like the initial s in the second member of sus-skeuazdō, is not eliminated, as shown by compounds like ek-spaō 'to draw out', ek-skeuos 'without equipment', ek-strateuma 'expeditionary force', ek-stasis 'displacement'. Note also that the sequence mn (sum-mnemoneuō), which includes mn, a cluster whose prosodic properties are identical to those of s-stop clusters, surfaces unaffected by Stray Erasure. Since Stray Erasure fails to apply in ek-spaō and sum-mnemoneuō we cannot invoke it sus-skeuazdō.

14. Note that this argument does not rely on the assumption that any skeleton-less format will share with Kaye and Lowenstamm's representations the property of positing empty onset nodes for all vowel initial syllables. The argument is thus logically distinct from the one made at the end of section (3.2.1).

15. For a list of the morphological environments in which g does not delete see Smyth 1976 : 154-155.

16. Spelled peratōn but containing a metrically guaranteed initial heavy syllable.

17. Some examples of Aeolic degemination: emi 'I am' for emmi ←== e^hmi, in a Thessalian metrical inscription where the meter indicates that the spelling emi is not a scribal error (Thumb 1909 240); epi-mēnios, mēna, both on mēn^h- 'month' which usually yields -mēnnios, mēna (Meister 1882 :68); en-k^hee also spelled en-k^heue (Alkaios 41, cited by Meister 1882 :95) from k^hew^he, underlying /k^heu-s-e/ 'pour-aorist-3rd.sg', where the light quantity of the second syllable indicates the degemination of the geminate w cluster of regular k^hewwe; bola (cited by Meister 1882: 143) for bolla ←== bol^ha, Att.-Ion. bōlē 'counsel'; imero-p^hgnos (Sappho 39) 'with lovely voice', whose first member, Att.-Ion. i^hmeros 'desire' (←== i^hmero-; cf. Skr. iṣmās- 'God of love', iṣ- 'to desire') should be immero- in Aeolic. One can also easily explain why 'degemination' is more frequent for underlying Cw clusters than for underlying Rh, hR sequences: recall that the assignment of Cw sequences seems to have been variably heterosyllabic and tautosyllabic both in the homeric dialect and in Ionic. Some amount of variation in this matter can also be attributed to Aeolic, in which case forms like ksenos, gona will have two sources: the degemination of attested ksennos, gonna (from earlier ksen.wos, gon.wa) and non-degeminated ksenos, gona (from earlier kse.nwos, go.nwa). If the incidence of correptio Attica is an indication in this matter, one may note that there are a few cases of tautosyllabic assignment of Tr clusters in Sappho and Erinna (gathered in Goebel 1876): it is then possible to claim that Cw clusters also allowed, if marginally, the same tautosyllabic assignment.

18. Lejeune (1972:129) suggests a different metathesis theory, according to which sonorant g sequences become g-sonorant and proposes

an additional argument for it: Osthoff's Law, which shortens a long vowel before a sonorant-C sequence, had not applied in mēnos ←-/mēns-os/ 'month-GENsg.' , Lesb. mēnnos, or in Att.-Ion. ōmos ←=ōmsos 'shoulder' . Had it applied, the Att.-Ion. forms would be mēnos, ōmos, with the long tense vowels resulting from CL and replacing intermediate shortened mē^hos or mēs^hos, ō^hos or ōms^hos; and Lesbian would show mēs^hnos. If we assume metathesis, whether of sonorant-s or sonorant-h sequences, and if this rule precedes Osthoff's Law, then we can explain the Att.-Ion. forms. If, moreover, Osthoff's Law precedes the gemination rule which turns Aeol. mē^hnos into mēnnos, that form too is accounted for. Note that the entire argument turns in fact on the existence of mēnnos, since all Att.-Ion. forms are explained if h-autosegmentalization and resyllabification precede Osthoff's Law. One should also note that the metathesis theory, insofar as its goal is that of explaining exceptions to Osthoff's Law, must restrict metathesis to the intervocalic position: āwsri- 'tomorrow' (on the root of h₂eōs) becomes aurion not *gūurion; ptērsnā 'heel' (cf. Skr. pārsniḥ, cited in Lejeune 1972:219) becomes Att. pternē. In both cases the original long vowel was shortened, as if no metathesis was involved. This limitation on the proposed rule seems arbitrary and reduces the merits of the argument for metathesis.

19. I have not addressed directly the question of whether the lost consonant and the vowel lengthened in compensation for its loss must be tautosyllabic. We know that loss of an onset w, when not accompanied by the resyllabification of a preceding segment does not activate CL: ne.wos 'young' becomes nē.os in all dialects that lose w. But we do not know in advance of analysis whether a postnuclear

consonant which is not in the onset and not in the rime (as in (i)) will delete with or without CL:

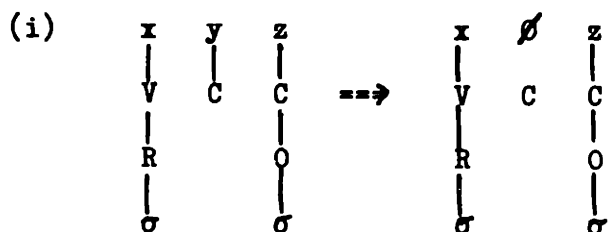

The statement of (1) assumes that the consequence of an operation like (i) will be no CL. The reason is formal: in order to rule out CL as a direct consequence of the deletion of an onset segment (like the loss of w in news) it is easier to restrict the environment of CL to tautosyllabic segments, as we have done in (1), than to stipulate that lost segments in the onset are disregarded.

20. We will continue to have to stipulate, as all other accounts, that only mid vowels give a phonetic interpretation in terms of tenseness to the $\begin{matrix} \text{V} \\ \text{V} \\ \text{x} \end{matrix} : \begin{matrix} \text{V} \\ \text{C} \\ \text{x} \end{matrix}$ contrast.

21. Paul Kiparsky (p.c.)

Chapter 3 : Attic Syllable Structure

1. Introduction

This chapter contains the main elements of an analysis of Attic syllable structure: it discusses the available evidence on the surface syllabic assignment of consonant clusters; it builds from it an analysis of Attic onset and coda structure; it puts forth a hypothesis about the relation between phonotactics and syllabification in this dialect; it argues for a number of ordering statements about syllabification operations.

The chapter is built around one of the proposed syllable building rules of Attic. This rule, given in (1), says that a stop may be incorporated into a rime just in case it is segmentally linked (in the sense discussed in Chapter 1 section 1.3.1) to a following position in the word template: a skeleton slot already incorporated into syllabic structure or an extrametrical word final slot.

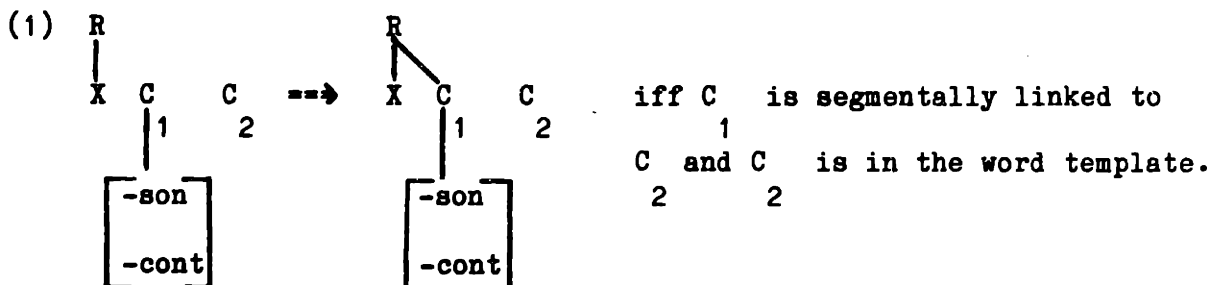

The interest of rule (1) is that it provides us with important information on the process of syllabification. Thus the environment of (1) mentions a skeleton slot, C₂, whose syllabic status must

already be determined by the time (1) applies: C_2 is in the word template by virtue of holding a position in a following syllable or by virtue of being the extrametrical consonant allowed at the end of Greek words. This implies that the rules determining whether C_2 is or is not part of the next onset apply before rule (1): I will take here the position that the rules providing for the creation of Attic onsets are ordered before (1).

Rule (1) will also figure prominently in clarifying another aspect of the derivational history of Attic surface syllabification: in discussing the assimilation rules that bring about the segmental link mentioned in rule (1), we will discover that many of them require that the segments undergoing them be heterosyllabic. We will see for example that minimally different clusters like pn and bn differ in their ability to undergo a rule of nasal assimilation: bn becomes mn but pn does not. This fact will be seen to correlate with a difference in syllabic assignment: pn is an onset cluster in Greek whereas bn, and any other voiced stop -nasal sequence, is not. We will observe however that underlying clusters satisfying the description of Attic onsets also act heterosyllabic in that they do undergo certain assimilation rules when they are separated by a major (level 2) suffixal boundary. This, we will attribute to the fact that the syllabification rule creating complex onsets like pn is a level 1 rule which stops applying after level 2 affixation. The segmental linking condition on rule (1) will provide one of the steps in this argument: a cycle final sequence like



cannot be fully syllabified on the relevant cycle because the stop does not satisfy the conditions of rule (1). The cycle final p is stray and thus is in principle available for syllabic incorporation on the next cycle: it should undergo the onset formation rule responsible for onset clusters like pn, if a sonorant follows. If it does, it should become inaccessible to assimilation rules requiring heterosyllabic clusters. Thus the observation that such assimilation rules do apply when an underlying cluster like pn is separated by a level 2 suffixal boundary is an indication that the relevant onset formation rule ceases to apply at level 2.

This partial difference between the syllabification of different levels is quite revealing. If syllabification processes are structure-building rules with the same ordering privileges as cyclical phonological rules then we would expect exactly this sort of situation: some syllabification rules could be restricted to certain lexical levels, others will apply throughout the lexical component, still others could be post-lexical.

The structure of the chapter is as follows: after selecting what I think are the only reliable indicators of the syllabic assignment of consonant clusters, I give an analysis of the Attic onset structure. The analysis of coda structure which follows requires a long excursus into the segmental assimilation rules that create the conditions of applicability for rule (1). I establish what clusters of stop - consonant are segmentally linked matrices and, in some cases, I give

arguments based on the Greek evidence that the relevant assimilation rules must be autosegmental operations. Finally, I show how onset and coda structure interact in predicting which underlying clusters will be exhaustively syllabifiable and which ones will be only partially so: we will see that only the syllabified portions of the latter surface word internally.

2. Evidence for syllabification in Attic

Eduard Herrmann mentions in the introduction to his 1923 study of syllabification in Greek and Indo-European six sources of information used by him in determining syllabic divisions in Greek:

(a) The so-called Rhythmic Law governs the alternation between -otero-/-ōtero- and -otato-/-ōtato-, the comparative and superlative allomorphs. The versions with a lengthened theme vowel follow in general a light stem final syllable. So from clear contrasts like kōp^h oteros 'lighter': neōteros 'younger' one can hope to determine the syllabification of less clear cases like makroteros 'longer'.

(b) Wheeler's Law is an accent retraction phenomenon: final accented words of dactylic rhythm (-σ̄σσ̄//) retract their accent onto the penult. Again, the behavior of some clear cases like *poikilós ⇒ poikílos 'variously colored' is used to determine the syllabification of clusters whose assignment is debatable like *patrasi ⇒ patrási.

- (c) Partial and total assimilation rules: Herrmann assumes that such assimilations take place only among members of a heterosyllabic cluster. He provides a list of systematic and sporadic cases of assimilation documented throughout the Greek territory.
- (d) Compensatory Lengthening (CL) following loss of a segment: Herrmann is aware of the fact that the prosodic weight of a syllable, which he assumes CL is meant to preserve, concerns only rimes, not onsets. Thus the loss of a ~~segment~~ with ensuing CL is used as an indication that it had occupied a rime position,
- (e) Prosody: here Herrmann takes the position that a syllable scanned as heavy by the meter is closed or contains a long nucleus<1>. Accordingly, the prosodic behavior of consonant clusters, their ability to 'make position', is taken as evidence of syllabic assignment.

(f) Spelling: one dialect of Ancient Greek, Cypriot, has a syllabic script whose limited inventory of signs (only CV, V syllables correspond directly to a sign in the Cypriot syllabary) requires special conventions for representing complex onsets and codas. These conventions appear to depend on the syllabification of consonant sequences: clusters are broken up into CV units by copying after each consonant the nuclear vowel of the syllable to which that consonant belongs. Less useful indications about syllabic boundaries come from frequent geminate spellings of the type essti (for esti), which Herrmann takes to show that the geminate consonant is ambisyllabic.

I would like to add the following remarks on Herrmann's tests:

(a) The Rhythmic Law is clearly not an alternation reflecting Attic 5th and 4th century syllabification: some of the relevant facts are listed below:

- (2) a. clear $\check{\sigma}$ cases: ne.ḡteros, k^hale.pḡteros 'more difficult',
at^hro.ḡteros 'more crowded'
- b. clear $\bar{\sigma}$ cases: h^hetai.rotatos 'closest companion', au.totatos
'the very same', kḡ.p^hoteros 'lighter', lep.toteros 'more delicate'.
- c. unclear cases with $\check{\sigma}$: pikroteros 'sharper', makroteros 'longer',
kednotatos 'the most careful', ekpaglotatos 'the most violent'.

- d. unclear cases with ō: emmetrōtatos 'most proportioned', erut^hrōtatos 'the reddest', euteknōtatos 'most blest with children', barupotmōtatos 'most grievous', duspotmōteros 'unluckier'.
- e. *Cw clusters with o: kenoteros (*kenwo-) 'emptier', stenoteros (*stenwo-) 'narrower'.
- f. *Cw clusters with ō: kenōteros, stenōteros.

The fact that Plato uses (2.e) along with (2.f) forms (kenoteros as if ken.wo.te.ros, alongside expected kenōteros) even though he speaks a dialect which not only has lost w long before the 5th century but also has lost it in onset position (see Chapter 2, section 3.1), is revealing and sufficient to eliminate this test. The variation in syllabic assignment implied by pikroteros vs. erut^hrōtatos could be dialect internal but could also reflect the same phenomenon of dialect borrowing that must be responsible for kenoteros, sténoteros. Since the source of the borrowing is unknown, the test becomes useless.

(b) The evidence for Wheeler's Law comes primarily from compound formations like boē-drómos 'who runs to a cry for aid', patro-któnos 'who kills one's father' (the latter syllabified pa.trok.to.nos according to all other available indications). But analogical extensions of the law also clearly exist. The following are cited by Vendryes (1945): dikaio-lógos 'judge', lit^h o-bólos 'thrower of stone', lōto-p^h ágos 'lotus eater', nausi-póros 'traveler by ship', oiko-nómos 'who manages a household', polu-lógos 'who speaks a lot', udro-k^h óos 'who pours water', ulo-tómos 'felling wood'. Within the synchronic grammar of Attic the accent pattern of active compounds like the ones

cited need not and cannot be derived via Wheeler's Law from underlying oxytone-accented forms. In fact a look at the accentuation of the forms ending in a dactyl listed in Kretschmer-Locker (1963) not only fails to reveal words containing the relevant clusters but also shows that the law itself is of dubious validity. Clear counterexamples like adelp^heós (a.del.p^he.os) 'brotherly', nau-agós (nau.a.gos) 'causing shipwreck', aigōliós 'a small kind of owl', the adjectives or nouns derived by the suffix -kó- (malt^hakós 'soft', p^harmakós 'scapegoat' etc.) turn out to be at least as numerous as the alleged cases of Wheeler Law retraction<2>. This test also must then be eliminated.

(c) My conclusion in section 5.3 below will be that Herrmann was right in thinking that most if not all segmental assimilation rules occur between the members of a heterosyllabic cluster. One may stress however that there is no a priori reason why this should be so. The heterosyllabic assignment of the cluster undergoing partial or total assimilation is a point to be established for each cluster and each assimilation rule rather than something that can be taken for granted. Nevertheless it is interesting to note that in Herrmann's survey of gemination phenomena attested in various Greek dialects one type of consonant clusters systematically fails to assimilate in any respect: the stop-r, voiceless stop-l clusters, that is, the sequences for which tautosyllabic assignment is most frequently indicated by other types of evidence.

(d) Herrmann's use of CL evidence in determining the syllabification of clusters that were later simplified presupposes a position close to that defended, after Ingria (1980), in the preceding chapter.

(e) Prosody is our richest source of information about the syllabification of Greek but clearly not a very reliable one. I will mention here only two reasons to doubt that the metrical behavior of a given consonant cluster reflects directly and exclusively its syllabic assignment.

In Latin the distribution of consonant clusters between adjacent syllables can be deduced from the stress pattern of trisyllabic or longer words. When the penult syllable is light, stress falls on the antepenult (gé.ne.ra, áu.di.ō, pál.pe.bra). Otherwise the penult is stressed (po.tés.tas, si.nís.ter, a.dúl.ter, a.má.re, a.mí.cus). There is no variation in the stress of words which, like palpebra, end in a sequence \check{V} Stop Liquid \check{V} C₆ and this indicates that the Stop-Liquid cluster is obligatorily assigned to the onset of the next syllable. However the metrical behavior of classical Latin (post-Terentian) poetry is different from what the stress facts indicate: the meter need not but may count such clusters as tautosyllabic, as if an optional rule had given structure to the complex Stop-Liquid onsets. It is the common opinion that classical Latin poetry deviates in the prosodic conventions relating to the syllabification of such clusters from the phonology of spoken Latin (cf. Allen 1972, Devine and Stephens 1977). In the post-homeric Greek poetry the same optional tautosyllabic assignment of certain Stop-Sonorant clusters is observed: they may but need not turn a preceding short vowel into a heavy syllable. Unlike in Latin, no single rule of Greek phonology has been used so far to confirm or disconfirm the optional status of the onsets in question. The testimony of Greek prosody remains, to that extent, suspect.

The second reason not to accept at face value the indications of the metrical syllabification is given by results like Magnien's (1920): in a study of prosodically related alternations in Homer, Magnien shows that the consonants s, r, l, m, n frequently act as geminates in closing a preceding syllable 'au temps fort' (in thesis) and frequently act as single consonants in leaving a preceding syllable light 'au temps faible' (in arsis). This happens regardless of the phonological make-up of the sequence, regardless of whether the underlying representations and the existing rules justify or not a geminate. Some examples: a feature of the homeric dialect is the geminate ss sequences in the future and aorist of the coronal stems. These geminate clusters result regularly from the underlying clusters d-s, t^h-s, t-s, s-s, where the final s is the future or aorist suffix, by a rule discussed in section 5.5.3. Magnien's facts indicate that these geminate ss clusters are treated by the homeric meter as if they result not from the obligatory rule of coronal cluster assimilation but from an optional rule of s gemination. In arsis they frequently fail to show up in forms where they are phonologically required (esetai 'will be' A 211, ēlase 'drove' Y 270, ^homēgurisast^h ai 'to have assembled' p 376, ekterisa 'buried' O 38, instead of essetai, ēlasse, ^homēgurissast ai, ekterissa). In thesis they appear in forms where they have no phonological justification (anussest^h ai 'to effect' p 373, ēp^h usseto 'drew (a liquid)' ps 305). Similar is the behavior of root- or word-initial s, m, n, l, r: some roots have underlying or intermediate ss, sm, sn, sl, sr initials whose regular phonological behavior in this dialect and stage of Greek should be to turn a preceding short vowel into a heavy syllable. What

Magnien found is that the cluster behavior of surface s,m,n,l,r initials extends, 'au temps fort', to roots that have underlying simple s,m,n,l,r; and, conversely, that some underlying ss,sm,sn,sl,sr clusters behave like simple consonants 'au temps faible'. Again, the phonologically expected distribution of clusters is distorted by what appears to be an optional rule: Geminate word or root initial sonorant or s. The variants afforded by the optional application of this rule are then selected for metrical convenience. The point relevant here is that this rule does not reflect the phonology of the spoken language. There is then little reason to believe that the poetic dialects of Greek should reflect more accurately cluster assignment than the homeric dialect does the segmental phonology of coronal clusters of s-sonorant clusters.

But this is not to say that the meter facts provide no useful evidence at all for syllabic structure. There are, for example, systematic deviations from Magnien's 'loi d'alternance' in the case of a few lexical items like sseuq̄ 'rush', whose initials count as geminates in arsis as well as in thesis. The rules of poetic license are not systematic enough to obscure all distinctions between underlying geminate and non-geminate initials. I will accordingly use the metrical evidence for syllabic assignment whenever its testimony can be supported by independent considerations or whenever it attests phenomena that appear unrelated to the needs of versification.

Looking back at Herrmann's list of tests for syllabic assignment we see that only two of those applicable to Attic survive a critical examination: CL effects and prosody. Of these the first one cannot

tell us much about the assignment of surface clusters: we can only use CL to determine whether a deleted consonant was part of the rime. The remaining test, prosody, must be used with caution as poetic conventions may be superimposed on the syllabification of the spoken language. As we begin now the analysis of Attic syllable structure we will learn how to validate the testimony of the meter by supplementing it with reliable indicators of syllabic divisions.

3. Syllabic divisions in the Attic prosody.

The 5th century Attic dialect reflected in the comedies of Aristophanes is characterized by a prosodic peculiarity known as correptio Attica, the Attic shortening. This is the traditional name for the tautosyllabic assignment of intervocalic clusters consisting of a voiceless stop followed by a sonorant or a voiced stop followed by r. While all other consonant clusters turn a preceding short vowel into a metrically heavy syllable, the clusters subject to correptio Attica leave a preceding vowel in an open rime.

(3) a. V.krV h[˘]ina taut' akroḡo[˘] anapestic meter

in order to hear these (Wasps 391)

b. V.grV k̄an Oīagros ēselt^{h̄g} p^{h̄eugōn} "

and if Oīagros comes before the court as accused
(Wasps 579)

c. V.k^h rV ∪ ∪ / - h' / - / ∪ ∪ / - / ∪ ∪ - /
poleōn ark ōn plēstōn apo tō Pontō mek^hri Sardōs "

ruling many cities from the Pont to the Sardis
(Wasps 700)

d. V.klV ∪ ∪ / - / ∪ ∪ / - /
anelontes kai kataklousantes anapestic meter

lifting up and crying (Wasps 386)

e. V.k^h lV - / ∪ h' ∪ / ∪ / ∪ /
dōloisi k^hlaniskidiōn mikrōn "

for the slaves small cloaks (Feace 1002)

f. V.knV - / - / - ∪ ∪ h' - / ∪ ∪ /
tēn dōleiān ōk apop ainōn apoknaiēs "

by not demonstrating the servitude you're annoying
(Wasps 681)

g. V.k^hnV $\cup \cup \frac{1}{/} \cup \cup \frac{1}{/} \cup \cup \frac{1}{/} \cup \frac{1}{-} \frac{1}{/}$
epoēse tek^hnēn megalēn umīn anapestic meter
he created a great art for us (Peace 749)

h. V.k^hmV $\cup \cup \frac{1}{/} \cup \cup \frac{1}{/} \cup \cup \frac{1}{/} \cup \cup \frac{1}{/} \cup \frac{1}{-} \frac{1}{/} \cup \cup \frac{1}{/}$
 $\cup \cup \frac{1}{/}$
hekaton de kuklōy kep^halai kolakōn oimōksomenōn
elik^hmōnto "
a hundred heads of accursed flatterers were licking
(Peace 756)

i. V.prV $\cup \cup \frac{1}{/} \cup \cup \frac{1}{/} \cup \cup \frac{1}{/}$
epi toisin apragmosin umōn anapestic meter
on those of you who are idle (Wasps 1040)

j. V.p^hr $- \cup \cup \frac{1}{-} \frac{1}{/} \frac{1}{-} \frac{1}{/} \cup \cup \frac{1}{/} \frac{1}{-} \frac{1}{/} \frac{1}{-} \cup \cup \frac{1}{/} \cup \cup \frac{1}{/}$
panta pep^hraktai kōk estin opēs ōd'ē serp^hōy diadūnai
all routes are blocked; there is no hole not even for a
gnat to slip through (Wasps 352)

o. V.tlV $\text{— } \underline{\text{—}} / \text{— } \underline{\text{—}} / \text{— } \underline{\text{—}} \text{—} / \text{— } \underline{\text{—}} / \text{— } \underline{\text{—}} \text{—} /$
 kai ti blaptōs' ō sk^hetli' andrōn, tēn polin "

and why are they damaging, o most wretched among men,
 the city? (Frogs 1049)

p. V.tnV $\text{— } \underline{\text{—}} / \text{— } \underline{\text{—}} / \text{— } \underline{\text{—}} / \text{— } \underline{\text{—}} / \text{— } \underline{\text{—}} / \text{— } \underline{\text{—}} /$
 kalōs. Kalōs dēt', ō potni' Ērēnē philē iambic hexameter

Well. Well, certainly, o dear Lady Peace (Peace 1055)

r. V.t^hnV $\text{— } \underline{\text{—}} \text{—} / \text{— } \underline{\text{—}} \text{—} / \text{— } \underline{\text{—}} \text{—} / \text{— } \underline{\text{—}} \text{—} / \text{— } \underline{\text{—}} \text{—} /$
 kân apot^hnēskōn, o patēr tōy dōy katalēpōn
 paid' epiklēron iambic hexameter

and if a dying father gives to someone by bequest his
 daughter, his unique heir (Wasps 583).

I am following here the opinions of White (1912: 364) and Schade (1909) that correptio is obligatory everywhere in the Attic comedy where a conscious parody of the tragic style is not attempted. Thus the clusters that can be tautosyllabic must be so in the verse of the Attic comedy.

What is an exceptionless law in the prosodic practice of Aristophanes is documented as a possibility in the writings of the tragic poets.

- (4) a. Vlkr V $\bar{—} \frac{1}{\vee} \frac{1}{\vee} \frac{1}{\vee} \frac{1}{\vee} \frac{1}{\vee} \frac{1}{\vee}$ kētai de nekros peri nekrōy, ta nump^hika iambic hexameter
he lies there, a corpse next to a corpse
(Sophocles Antigone 1240)

- b. VknV $\frac{1}{\vee} \frac{1}{\vee} \frac{1}{\vee} \frac{1}{\vee} \frac{1}{\vee} \frac{1}{\vee} \frac{1}{\vee} \frac{1}{\vee} \frac{1}{\vee} \frac{1}{\vee}$ ōk ar'oknēsēs ? oknos gar tois p^hilois kakon mega "
and will you not hesitate? for this might bring
misfortune to your friends. (Euripides Orestes 794)

- $\frac{1}{\vee} \frac{1}{\vee} \frac{1}{\vee} \frac{1}{\vee} \frac{1}{\vee} \frac{1}{\vee} \frac{1}{\vee} \frac{1}{\vee} \frac{1}{\vee} \frac{1}{\vee}$
oikonomos doliā mnāmōn Mēnis teknopoinos dactylic hexameter
a treacherous guardian of the house, Menis who
remembers and avenges a child (Aeschylus Agamemnon 155)

- c. Vp^hIV $\bar{—} \frac{1}{\vee} \frac{1}{\vee} \frac{1}{\vee} \frac{1}{\vee} \frac{1}{\vee} \frac{1}{\vee} \frac{1}{\vee} \frac{1}{\vee}$ Ōtis me tup^h loi blep^h aron. Ōk ar' ē tup^hlos iambic hexameter
Nobody is blinding my eye. Are you not blind?
(Euripides Cyclops 673)

- d. VbrV $\bar{—} \frac{1}{\vee} \frac{1}{\vee} \frac{1}{\vee} \frac{1}{\vee} \frac{1}{\vee} \frac{1}{\vee} \frac{1}{\vee} \frac{1}{\vee}$ All'ōk^h h^hubris tad' ? h^hubris all'anektea iambic hexameter
Is this not insolence? It is, but you must suffer it.
(Sophocles Oedipus in Colonus 883)

- e. VtrV $\bar{—} \frac{1}{\vee} \frac{1}{\vee} \frac{1}{\vee} \frac{1}{\vee} \frac{1}{\vee} \frac{1}{\vee} \frac{1}{\vee} \frac{1}{\vee}$ All'en petroisi petron ektribōn, molis iambic hexameter
But by rubbing a stone against stones, barely
(Sophocles Philoctetus 296)

- $\frac{1}{\cup}$ $\frac{1}{\cup}$ $\frac{1}{\cup}$ $\frac{1}{\cup}$ $\frac{1}{\cup}$ $\frac{1}{\cup}$
Eks^hēys Atreus eblasten; Atreōs de pais

iambic hexameter

From whom Atreus sprang; but his child
(Euripides Iphigenia in Tauris 3)

Occasionally both Aristophanes and the tragic poets will count bl
and, more seldom, gl as tautosyllabic:

- $\frac{1}{\cup}$ $\frac{1}{\cup}$ $\frac{1}{\cup}$ $\frac{1}{\cup}$ $\frac{1}{\cup}$ $\frac{1}{\cup}$

(5) a. ēnai; bublō de karpos ō kratē stak^hun iambic meter

the fruit of the papyrus does not command
over the ear of corn (Aeschylus Suppliants 761)

- $\frac{1}{\cup}$ $\frac{1}{\cup}$ $\frac{1}{\cup}$ $\frac{1}{\cup}$ $\frac{1}{\cup}$ $\frac{1}{\cup}$

b. eks^hēs eblastēs, ōk^hi Sīsūp^hō patros "

who you were born of; Sisyphos is not your father.
(Sophocles Philoctetus 1311)

- $\frac{1}{\cup}$ $\frac{1}{\cup}$ $\frac{1}{\cup}$ $\frac{1}{\cup}$ $\frac{1}{\cup}$ $\frac{1}{\cup}$

c. Orp^hēs de glōssān tēn enantiān ek^hēs "

your voice is the opposite of Orpheus'
(Aeschylus Agamemnon 1629)

- $\frac{1}{\cup}$ $\frac{1}{\cup}$ $\frac{1}{\cup}$ $\frac{1}{\cup}$

d. ardō^hopōs anablastanēys "

I will water you so that you may spring again
(Aristophanes Lysistrata 384)

Even more exceptional are the cases where a sm or mn cluster fails to
lengthen a preceding syllable. Koster (1952: 35) cites four such
instances, all involving mn.

We should note at this point one aspect of the syllabification
required by the meter: within a verse word and root initial clusters

have the same syllabic assignment that they receive word medially. In particular, word initial clusters that are neither a voiceless stop followed by a sonorant nor a voiced stop followed by r will turn the final vowel of a preceding word into a heavy syllable, exactly as they do in word medial position.

(6) a. V][glV $\text{Priam}\bar{o}; \text{dikas gar } \bar{o}k \text{ apo gl}\bar{o}ss\bar{e}s \text{ t}^h \text{ eoi}$ iamb hexameter
 for the gods (did not hear) the defense
 (Aeschylus Agamemnon 813)

b. V][gnV $\text{Kai m}\bar{e}n \text{ tod}'\bar{e}pe \text{ m}\bar{e} \text{ para gn}\bar{o}m\bar{e}n \text{ emoi}$ "
 Answer me now not contrary to my expectation
 (Aeschylus Agamemnon 931)

c. V][ptV $\bar{o}d' \text{ apo-ptusas, dik}\bar{a}n$ catalectic trochees
 $\text{duskrit}\bar{o}n \text{ on}\bar{e}rat\bar{o}n$
 and not spitting, as for obscure dreams
 (Aeschylus Agamemnon 980-981)

d. V][p^ht^h $\bar{o}den \text{ dia-p}^h \text{ t}^h \bar{e}r\bar{a}san \text{ en m}\bar{e}k\bar{e}^h \text{ k}^h \text{ ron}\bar{o}$ iambic hexameter
 destroying nothing during that length of time
 (Aeschylus Agamemnon 610)

- e. V][ksV $\text{— } \underline{\text{1}}/\text{v} \text{ v } \underline{\text{1}}/\text{vv} \underline{\text{1}}/\text{vv} \underline{\text{1}}/\text{v}$
 kai to ksip^hos ō dunamai katek^hēn anapestic meter
 and I can't hold on to my sword anymore
 (Aristophanes Wasps 714)
- f. V][skV $\text{— } \underline{\text{1}}/\text{v} \underline{\text{1}}/\text{—} \underline{\text{1}}/\text{v} \underline{\text{1}}/\text{v} \underline{\text{1}}/\text{vv}$
 kai tālla ta skeuē ta proskeklēmēna iambic hexameter
 and all the other assigned utensils
 (Aristophanes Wasps 939)
- g. V][splV $\text{v } \underline{\text{1}}/\text{v} \underline{\text{1}}/\text{—} \text{ }^{\text{h}} \underline{\text{1}}/\text{v} \underline{\text{1}}/\text{ }^{\text{h}} \underline{\text{1}}/\text{vv}$
 egō d'epi splank n'ēmi kai t ulēmata "
 I'm going to get the innards and the cakes
 (Aristophanes Peace 1040)

(6) illustrates a generalization which holds for all periods and styles of Greek prosody:

- (7) A metrical line is syllabified without regard to word and phrasal boundaries, as if it consisted of a single word.

Principle (7) is a preliminary statement of the parallelism between word medial syllabification (as in as.kē.sis, ^hag.nos) and the syllabification across major boundaries (as in ta skeuē = tas.keu.ē, para gnōmēn = pa.rag.nō.mēn). A full discussion of (7) is given in Chapter 4.

The difference between the optional tautosyllabicity of voiceless stop - sonorant, voiced stop - r clusters in the tragic and lyric poetry and their obligatory assignment to the onset in the language of

the Attic comedy reminds one of the difference between the prosody of comic Latin and that of the lyric, tragic and epic Latin. The stress facts indicate that only the Plautinian prosody reflects directly the syllabification of spoken Latin. One can also show that a parallel situation obtains in Attic: the prosody of Aristophanes is a simple projection of the syllabification rules of Attic while the variants like ne.kros, nek.ros found in the tragic and lyric poetry reflect the poetical convention given in (8):

(8) Assume that the Complex Onset Formation rule is optional.

Our argument begins with showing that there exists in Greek a rule which confirms, as stress does in Latin, that the clusters that may be tautosyllabic must be so.

4. Reduplication

There are two rules of reduplication in Greek. The present reduplication, which forms a few archaic present stems, consists, informally speaking, of copying the first consonant of the verbal root and inserting i between the copied consonant and the stem proper.

(9)	root	present stem	
	dō̄	didō̄mi	'to give'
	gnō̄	gignō̄skō̄	'to know'
	k ^h rē̄	kik ^h rē̄mi	'to borrow'

The perfect reduplication pattern breaks up into four sub-

classes: class (a) covers verbs that begin with one consonant or with a voicless stop - sonorant, voiced stop - r cluster: this class reduplicates in the perfect by copying the first stem consonant and inserting e between the reduplicates consonant and the stem. Class (b) includes verbs that begin with a consonant cluster other than voicless stop-sonorant, voiced stop - r: no overt reduplication takes place here, only the prefixation of the vowel e. Class (c) is the productive reduplication pattern for vowel-initial stems: in the perfect they simply lengthen their stem-initial vowels. The so-called Attic reduplication perfects of the type olōla (root ol 'to perish') are grouped under class (d).

(10)		stem	perfect stem	
a.	C	lū	le-lūka	'to untie'
		sēm̄an	se-sēm̄ēna	'to signify'
		klep	ke-klop ^h a	'to steal'
		tlā	te-tlamen	'to endure'
		plēg	pe-plēgmai	'to hit'
		knai	ke-knēsmai	'to scrape'
		pneu	pe-pneuka	'to breathe'
		t ^h nē	te-t ^h nēka	'to die'
		grap ^h	ge-grap ^h a	'to write'
		brīt ^h	be-brīt ^h a	'to be heavy'
		drā	de-drāka	'to pull'
		krag	ke-kraga	'to cry'
		t ^h rep ^h	te-trop ^h a	'to feed'

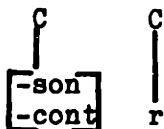
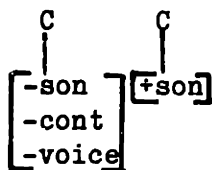

b.	C	C	sper	e-sparmai	'to sow'
	s	[-son] [-cont]	sbes	e-sbēka	'to extinguish'
			strep ^h	e-strop ^h a	'to turn'
	C	C	zdeug	e-zdeugmai	'to yoke'
	Z	[-son] [-cont]			
	C	C	smēk ^h	e-smēgmenos	'to wipe off with soap'
	s	[+son]	smuk ^h	e-smugmai	'to smoulder away'
	C	C	psau	e-psauka	'to touch'
	[-son] [-cont]	s	kse	e-ksēka	'to carve'
	C	C	ptai	e-ptaika	'to stumble'
	[-son] [-cont]	[-son] [-cont]	kten	e-ktona	'to kill'
	C	C	gnōrid	e-gnōrika	'to recognize'
	[-son] [-cont] +voice	[+son] [+ant]	gnō	e-gnōka	'to know'
			glup ^h	e-glup ^h a	'to sculpt'
			blasta	e-blastēka	'to sprout'
			gnupo	e-gnupōmenon	'to be depressed'

c.	angel	ā ngelka	'to announce'
	et ^h el	ēt ^h elēka	'to want'
	op ^h el	ōp ^h elēka	'to owe'
	h _{up} ^h an	h _{up} ^h asmai	'to weave'
d.	od	odōda	'to smell'
	ol	olōla	'to perish'
	ager	agāgerka	'to collect'
	eger	egēgermai	'to awaken'
	elek	elēlegmai	'to confute'

I will be concerned here with developing an analysis of the perfect reduplication that will explain the difference between classes (a), (b) and (c), while at the same time allowing for the lexical variation attested among vowel initial verbal stems between class (c) and (d). My analysis will require certain assumptions about syllabification: the one relevant for our immediate concerns is that voiceless stop - sonorant clusters and voiced stop - r clusters are obligatorily rather than optionally tautosyllabic.

The analysis is based on the autosegmental model developed by Marantz (1982) for reduplication rules. Marantz suggests that reduplication is not a formally distinct process from affixation. Rather, reduplication represents the affixation of an incompletely specified phonological unit, most frequently the affixation of a sequence of CV slots which lack, totally or partially, an associated segmental melody. The process of 'filling in' the empty CV slots can consist of associating them to neighboring segmental melodies, as in (11):

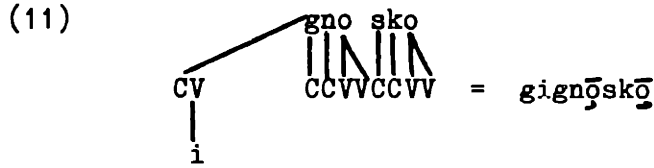

or it can consist of copying a neighboring segmental melody, which is then associated to the existing empty slots:

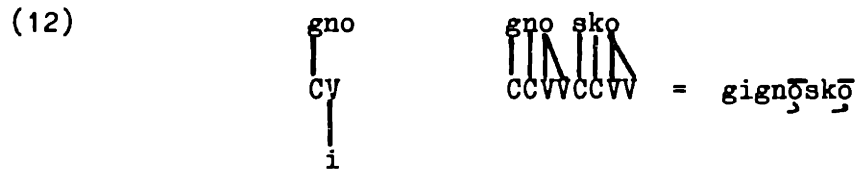

I have exemplified both options, association and copying, with the same example, the present reduplication of gignōskō. In both cases I have been assuming that the reduplication affix consists of a partially specified CV slot in which C lacks a segmental matrix but V is preattached to one, i. I am using here the convention initially introduced by McCarthy (1979), and mentioned in Chapter 1, according to which segmental melodies belonging to distinct morphemes are represented on distinct tiers. This is graphically realized here by writing the melody of the root above the CVC tier and the melody of the reduplicating affix CV, below. The distinct morpheme-distinct tier convention ensures that ⁱassociation lines do not cross in the analysis of gignōskō given in (11). Finally, the output gignōskō of the representation in (12) relies on the assumption of Stray Erasure (see Chapter 1, section 3.3). A different solution to the problem posed by stray segments would be to insert corresponding C or V slots which would allow them to surface.

Let us choose, arbitrarily for the moment, the analysis of present reduplication given in (11), as formulated below:

(13) Present Reduplication

a. Prefix CV to the root.



b. Associate C to the root melody.

The ban on crossing association lines will not prevent the reduplication C from linking to the first root segment but it will make any segments to the right of the first inaccessible to linking. Thus a vowel initial verb root will, under this analysis, be unable to link the initial C of the reduplication prefix to any segment of the root melody. The predicted result is attested in ia^hkk̄ (also spelled ia^hō

present stem meaning 'to cry', whose unreduplicated root ak^h appears in the participles amp^hia^huia 'shrieking around - FEM' and ak^hōn.

(14)

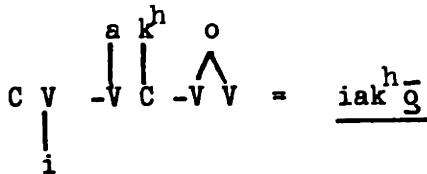

The ban on crossing association lines blocks *kia^hō:

(15)

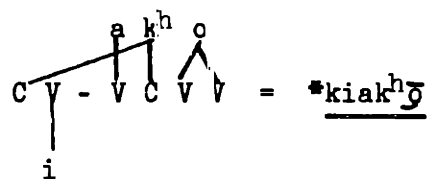

iak^ho also demonstrates that linking rather than copying is the correct analysis of gign^hask^ho: had we chosen to fill the empty C slot of the reduplication affix by copying the root melody we could not have blocked *kiak^ho:

(16)

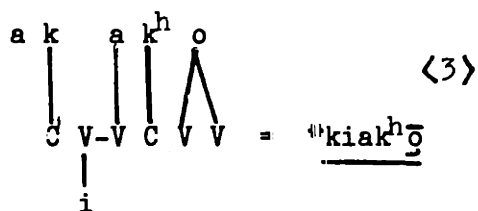

Turning now to the perfect reduplication we notice that the distribution between class (a) and class (b) can be described as: a root will reduplicate according to the class (a) pattern if it begins with an onset cluster; other consonant initial roots belong to class (b). On this basis we can state the perfect reduplication rule as in (17) below:

(17) Perfect Reduplication

- a. Prefix CV to the stem
- b. Associate the CV slots left to right to the segmental melody of the first root syllable.
- c. Attach an empty V slot to an inserted e.

The derivations of lelūka, gegrap^h a, egnōka, ōp^h ēlēka follow:

(18) lelūka gegrap^h a egnōka ōp^h ēlēka

1st cycle
output

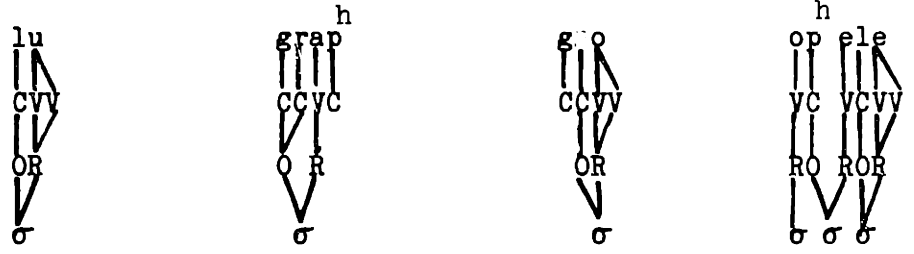

17.a

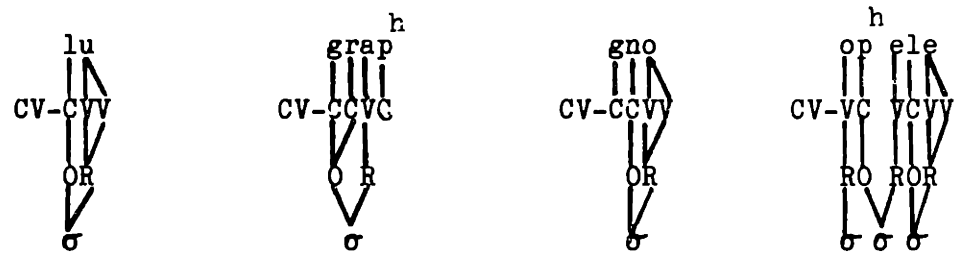

17.b

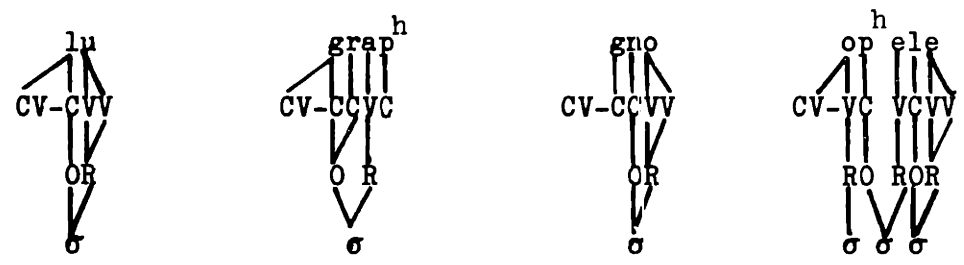

17.c

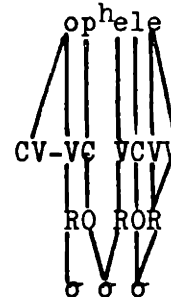
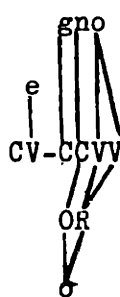
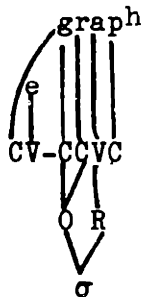

Syllab.

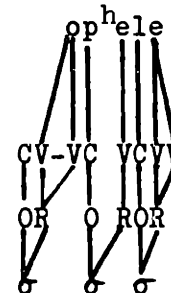
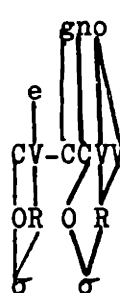
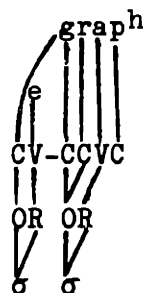

In Chapter 4 we shall see that roots like gnō enter the cycle of reduplication with an initial stray consonant, a fact which is simply assumed in what I have indicated as the output of cycle 1. The correlation between the metrical behavior of the class (a) and (b) initials and their respective patterns of reduplication should be sufficient at this point to justify some difference in syllabic structure. The C slots left empty by the failure of (17.b) in egnōka and ōp^hēlēka are erased at the end of the cycle along with other unattached material. Finally, note that there is no need to specify that the CV slots in the reduplication unit link up to segmental material in the first root syllable: other syllables are simply inaccessible to linking, by virtue of the crossing lines constraint.

The Attic reduplication pattern, class (d), appears to involve

two parameters of difference: (a) root copying rather than linking to the root is clearly the means whereby the reduplication unit receives its segmental specifications; (b) the prefixed unit is VCV. We obtain intermediate representations like (19):

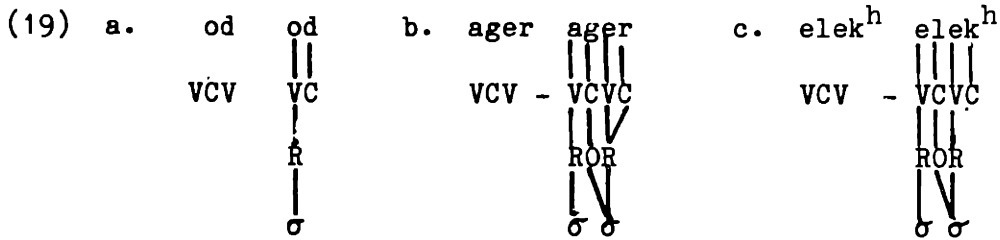

Left to right linking of the CV slots to the copied root melody should result in :

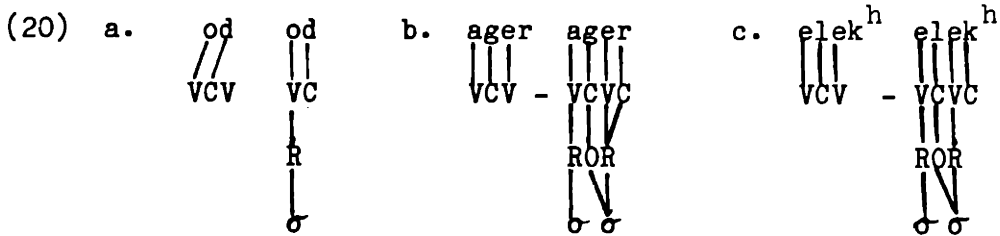

The second reduplication V must now be linked directly to root material rather than to copied root material. We obtain (21):

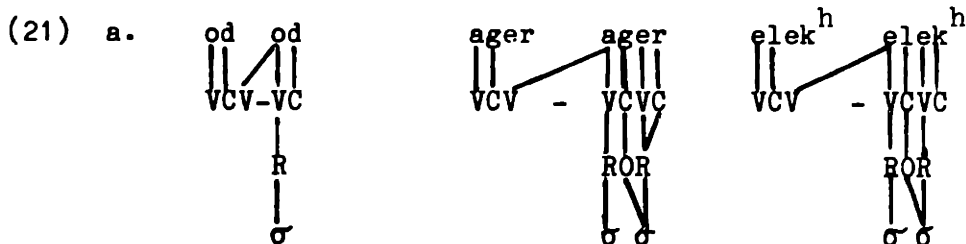

The derivations sketched above correspond to the following formulation of Attic Reduplication:

(22) Attic Reduplication

- a. Prefix VCV
- b. Copy root melody
- c. Link V to root segment.

Again, we need not specify which one of the prefixed V's will link up to a root segment: the ban on crossing lines will allow only the rightmost prefixed V to undergo (22.b).

We return now to the question that made an analysis of the perfect reduplication relevant: are the possibly tautosyllabic clusters of Attic also obligatorily tautosyllabic?

Suppose they are not, as the poetic tradition in which correptio is not obligatory seems to indicate. We would then predict alongside gegrap^ha, tetlamen, pepneuka variants like *egrap^ha, *etlamen, *epneuka, as one can see from the derivation below:

(23)

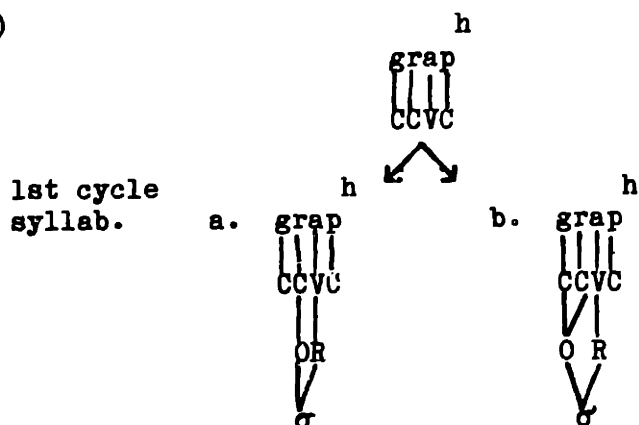

2nd cycle
(17.a)

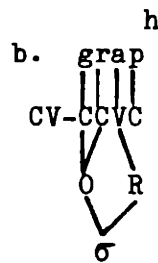
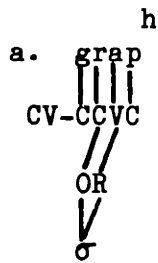

(17.b)

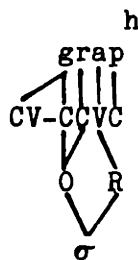
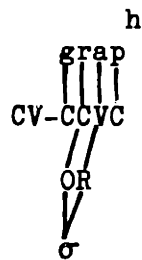

(17.c)

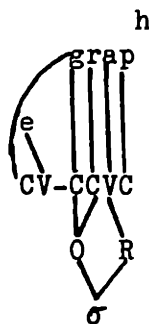
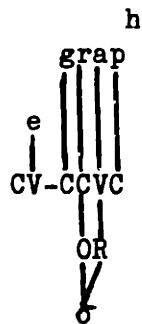

eventually

*eg.ra.p a

ge.gra.p a

This argument would not amount to much had there been no attested variation in the formation of certain reduplicated perfects. But such variation exists and, significantly, it correlates with the variable syllabification of the relevant clusters in the Aristophanic prosody. Roots with bl, gl initials appear to have admitted both class (a) and class (b) perfect reduplications: as the examples in (5) show, such clusters showed a variable, heterosyllabic as well as tautosyllabic

assignment in all poetic styles of Attic, including in Aristophanes. Thus, out of 5 verbal roots that begin with bl and whose perfects are attested, 3 have both class (a) and class (b) reduplicated variants:

- (24) a. blaisoomai 'to be crooked'
class (a): beblaisōtai
class (b): eblaisōtai
- b. blaptō 'to hinder'
class (a): beblap^ha
class (b): eblap^ha
- c. blastanō 'to sprout'
class (a): beblastōka
class (b): eblastōka

The remaining two verbal roots with a bl-initial, blasphēmō 'to speak irreverently' and blepō 'to look' have only their class (a) variants attested: beblasphēmōka and beblepō^ha or beblōp^ha. Only two gl-initial roots have attested perfects. Of these glupō 'to carve' has both class (a) and class (b) variants: geglummai as well as eglummai. Glōttizdō 'to kiss lasciviously' has a once attested class (b) reduplication: kateglōttismenon (Aristophanes, *Thesmophoriazousai*, 131).

Thus, the variation between class (a) and class (b) reduplications corresponds to the variable assignment of clusters indicated in the comic prosody: it is limited to bl, gl clusters<4>. The ne.kros, nek.ros variants of the tragic and lyric poetry are not paralleled by

variations in the output of any syllable sensitive rule. (Recall that we must attribute the makroteros/makrōteros variants to the same process of interdialectal borrowing that is responsible for stenoteros.)

This constitutes our first argument that the tautosyllabic stop-sonorant clusters of Attic are obligatorily so. A second argument will come from the analysis of Attic coda clusters developed in the next sections. It can be summarized as follows: a number of apparent exceptions to compensatory lengthening (as stated in (1) Chapter 2) and the restrictions on word final consonants and consonant sequences that hold in Attic can be explained as due to the fact that stops can be assigned a position in the rime only subject to the segmental linking condition in (1):

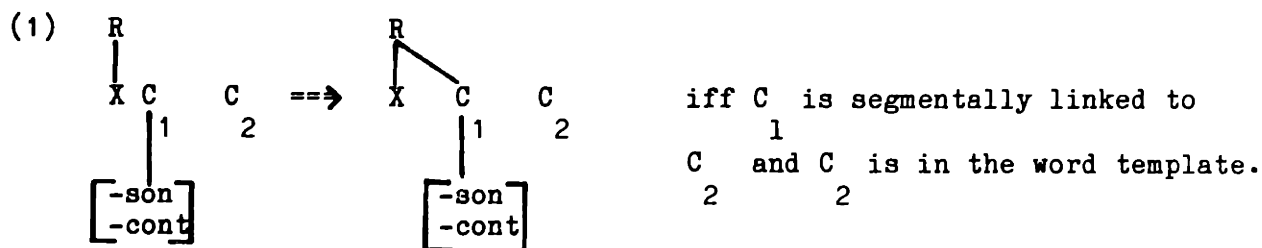

Consider now the following stop-sonorant clusters of Attic, all of which are possible onsets: kn, k^h_n, pn, p^h_n, tn, t^h_n, km, k^h_m, tm, t^h_m, kl, k^h_l, pl, p^h_l, tl, t^h_l, kr, k^h_r, pr, p^h_r, tr, t^h_r. No segmental link obtains between the members of these clusters: none of the assimilation rules of Attic applies to them. The segmental linking condition in rule (1), whose advantages will be demonstrated shortly, predicts that they cannot surface as heterosyllabic.

5. Syllable structure and cluster simplifications

5.1 Introduction

We have found so far two reliable tests for the division of biconsonantal clusters in Attic: perfect reduplication and the aris-tophanic prosody. Our goal however is not only to reconstruct the surface facts of Attic syllabification but, primarily, the system of rules which derives these facts. So far we have simply discovered some of the data to be accounted for: we know that the Attic complex onsets are clusters of stop - sonorant, where the sonorant is r if the stop is voiced. We also know that most such clusters are obligatorily assigned to the onset position, the exceptions being bl and gl, which may, but need not, be tautosyllabic.

Knowing the syllabic assignment of biconsonantal clusters in Attic tells us remarkably little about possible coda sequences: we might think that once we will have drawn the inventory of all attested consonant clusters we will be able to obtain the list of attested Attic codas by removing the onsets. But this method cannot tell us by itself whether a triconsonantal cluster like the one in pemptos 'sent' is divided as pem.ptos or pemp.tos or even pem.p.tos, with a stray medial p: pt is, we know, not a possible onset but it is a possible word initial sequence. The grammatical statement that allows it in word initial position might also allow it word medially after a coda. Thus a factual question like that of the syllabic division in pemptos could be answered only by settling the grammatical point: finding the correct form of the statement which allows some non-onset clusters in word initial position.

I propose to settle this question by relying on the hypothesis that all consonant cluster simplifications of Attic, aside from those that lead to CL<5>, represent the effect of Stray Erasure: the elimination of segmental material and skeleton slots that have not been assigned a syllabic position. Thus the comparison between underlying and surface clusters will provide us with a list of unsyllabifiable sequences: the clusters which underwent simplification. We will find among them sequences which contain the non-onsets allowed word initially: for example underlying sequences like C-s-stop lose the medial s even though the s-stop cluster is well attested in word initial position. This will indicate that the rule allowing word initial non-onset clusters to surface is restricted to word initial position: medially all clusters must be parsable as coda-onset sequences. For pemptos and similar cases this conclusion will decide in favor of the pemp.tos division. We will have obtained in this way the facts on which to base a partial theory of Attic onset and coda structure.

5.2 Possible clusters and their distribution

I will follow here primarily the survey done by Lupag (1972: 136) of possible consonant clusters in Attic. I have sometimes supplemented her examples with my own and departed from her conclusions on what clusters belong to the Attic dialect in only one respect (cf. footnote 6). For the moment I will be concerned only with the clusters that are either tautomorphic or else belong to the same compound member. Clusters that arise only at compound boundaries will be discussed in Chapter 4. Relying on the conclusion of section 4, I indicate for each medial cluster where the onset of the second

syllable begins.

(25) Word Internal Clusters

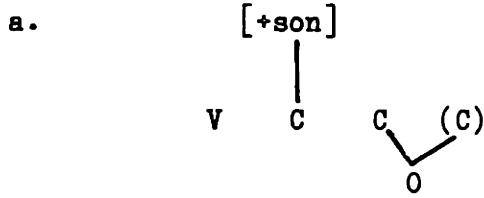

ar.nos 'lamb', or.n^h 'onset', or.p^hn^h 'darkness', ar.t^hron 'joint',
ar.t^hmos 'bond', tol.ma^h 'to dare', el.pis 'hope', Al.km^h.n^h,
an.t^hr^h.pos 'man', gi^h.glu.mos 'hinge', am.blus 'dull'.

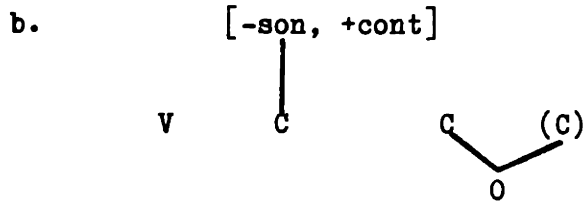

di.das.k^h 'to teach', les.k^h 'lounge', p^has.ga.non 'sword',
As.kl^h.pi.os, is.k^hnos 'lean', es.pe.ra 'evening', os.p^hrai.no.mai
' smell', pres.bus 'old', as.tron 'star', es.t^hi.^h 'to eat',
as.t^hma 'panting', es.t^hlos 'good', des.mos 'fitting', ktiz.d^h
'to found'.

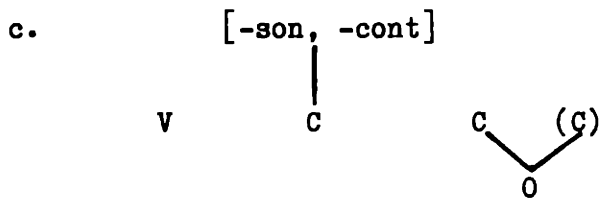

ok.t̄g 'eight', oik.tros 'pitiable', ek^h.t^hros 'hateful',
prag.ma 'deed', ag.nos^h 'holy', ek-pag.los 'frightful', skep.sis
 'consideration', skēp.tron 'sceptre', ep.t^hos^h 'boiled', eb.do.mas^h
 'week', ked.nos 'careful', pap.pos 'grandfather', prat.t̄g 'to do',
Bak.k^hos, ap.p^hus 'daddy', tit.t^hos 'breast'. <6>

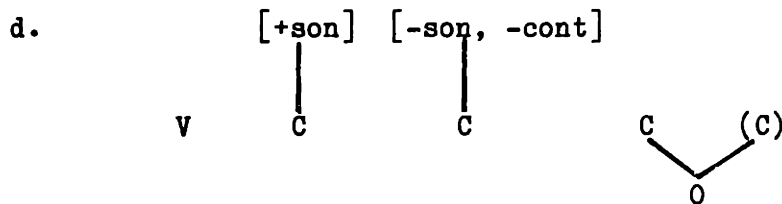

ark.tos 'bear', ark.sai 'to have begun', e.derk^h.t^hēn 'I was seen'
a.elp.tos 'unhoped for', e.melp.sa 'I sang', t^helk.t̄g.ri.os
 'soothing', t^helk.tron 'charm', e.t^helk.t^hēn 'I am enchanted'
ek.s̄g.melg.me.non 'pressed out (of milk)', p^ht^henk.tos 'uttered'
e.lenk^h.t^hēn 'I was proven guilty', pemp.tos 'sent', smerd.nos
 'power, force'

(26) Word Final Clusters

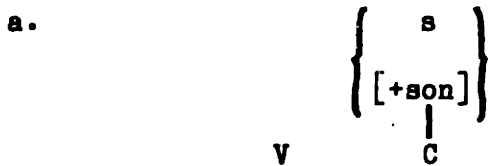

ant r̄gpos^h 'man-NOM', ant r̄gpon^h 'man-ACC', pūr 'fire'.

b.

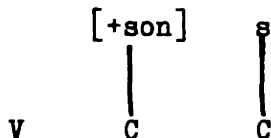

h_{als} 'sea', h_{ens}. 1.<7>

c.

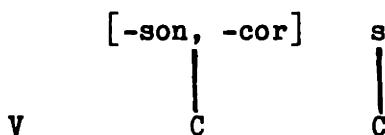

p^hleps 'vein', t^hgraks 'chest' .

d.

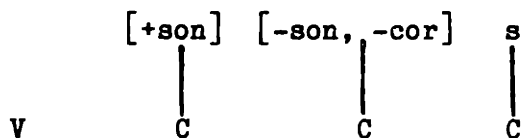

lunks 'lynx', k^hremps 'a kind of fish'.

(27) Word Initial Clusters

a. Onsets

krāsīs 'mixture', kleptō 'to steal', knepas^h 'darkness'

k^hreos 'debt', k^hlidē 'delicacy', k^hnoē 'nave', grap^hō

'to write', glup^hō 'to carve', prōtos 'first', plēn 'except'

pneō 'to breather', p^hrazdō 'show', p^hlauros 'petty', brotos

'mortal', blabō 'damage', trep^hō 'to feed', tlaō 'to endure',

taōtos 'cut', t^hriks 'hair', t^hlibō 'squeeze', t^hneyskō 'to

die', drūs 'oak'.

b. Other clusters

I [-son, +cont]

|
C

C (C)
|
O

smēk^hg 'to wipe clean', skaptō 'to dig', sklēros 'hard',
sknip^hos 'stingy', sk^holō 'leisure', spaō 'to draw',
splan^hna 'innards', sp^hrāgis 'seal', stratos 'army',
stlēngis 'scraper', zdugon 'yoke'.

II [-son, -cont, -cor] [-son, † cor]

|
C

|
C
|
O

ktēnō 'to kill', k^ht^hes 'yesterday', ksenos 'stranger',
ptuttō 'to spit', p^ht^hērō 'destroy', bdeluros
'disgusting', psauō 'to touch'.

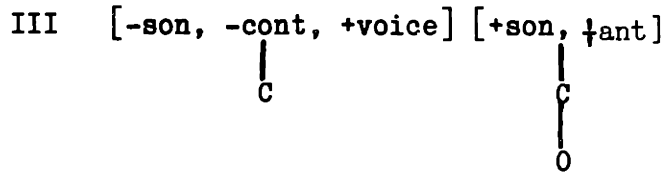

gnōmē 'judgment', dnop^hos 'darkness'.

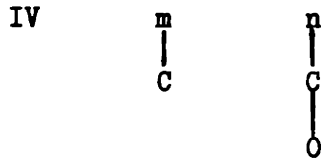

mnēmōn 'mindful'.

(25), (26) and (27) give us a general picture of the clusters of Attic. Let us list now what systematic gaps can be found: first, if we remove the onset from a medial cluster, we observe that the remaining sequence never contains more than two consonants, the second of which is less sonorous than the first. Of these, the first is always a sonorant, the second always a stop. Neither the continuant obstruents, s and z, nor the voiced stops occur in a sequence VC__Onset V: no word like *p^ht^hengdos corresponds to the attested p^ht^hengktos, no form *alstos or *alzdos can be found medially to parallel the final -ls cluster attested in als^h. In general, word final sequences show the ability to add a final s to what is otherwise a cluster that can occur internally before an onset. The other significant gap is that there are no obstruent clusters the second member of which is not a coronal: pt, ps, tt, st sequences are attested, but *tp, *tk, *pk, *kp clusters are not. We except from this generalization the geminates pp (as in pappos), kk^(h) (as in iakk^hg): they

contain a single segment linked to two C slots. Finally, a large number of the restrictions on clustering that can be deduced from (25) and (26) follow from the operation of assimilation rules: for example, obstruent clusters agree in voice and aspiration, nasal-stop sequences agree in place of articulation.<8>

In the next section we compare attested and underlying sequences, seeking to determine what clusters have exceeded the possibilities of the rime and onset structure of Attic.

5.3.1 Cluster simplification

A number of underlying and intermediate consonant clusters are simplified in Greek, word medially as well as word finally. Their list is given in (28)-(29):

(28) Triconsonantal cluster simplification

- a. C C C : /e-stal-st^hai/ 'to have sent' => estalt^hai

+cont
-son

/ CV-p^han-st^he/ 'you have been revealed' => pep^hant^he
/ CV-grap^h-st^hai/ 'to have been written' => gegrap^h t ai
/ ^heps-to-s/ 'boiled' => ^hep^h t os <9>
/ plok-smos/ 'locks' => plok^h mos
/ erg-y-ḡ/ 'to work' => erzzḡ => erzḡ
/ pant-ya/ 'all-FEM' => panssa => pansa => pāsa
/ CV-teles-st^hai/ 'to have been accomplished' => tetelest^hai

- b. C C C
 [-son] [-son]
- /pat^h-sk-ō̄/ 'to suffer' => past^hkō̄ =>
past^hk^hō̄ => pask^hō̄
- /lak-sk-ō̄/ 'to shout' => laskkō̄ => laskō̄
- c. C C C
 [+nas] [-son
 +high
 +voice]
- /p^ht^heng-mat/ 'voice' => p^ht^henma <10>
- /CV-elerk^h-mai/ 'I have been confuted' =>
elēlēngmai => elēlēnmai
- d. C C C
 [+son]
- /CV-pemp-mai/ 'I have been sent' =>
pepemmai => pepemmai

(29) Biconsonantal cluster simplification

- a. C C
 [-son] [-son
 -cont]
- /anakt/ 'lord' => ana
- /galakt/ 'milk' => gala
- b. (C) C
 [+son] [-son
 -cont]
- /damart/ 'spouse' => damar
- /sō̄mat/ 'body' => sō̄ma
- /melit/ 'honey' => meli
- /gunaik/ 'woman-VOC' => gunai
- c. C C
 [-son] [-cor]
 +cor]
- /CV-komid-k-a/ 'I have provided' => kekomika
- /CV-pēt^h-k-a/ 'I have persuaded' => pepēka
- /CV-anut-k-a/ 'I have accomplished' => ēnuka
- /CV-erēd-k-a/ 'I have propped' => ērēka

(28) and (29) illustrate all of the attested cases of consonant loss without CL in Attic. For each cluster listed in (28) we note that its last two members do not form a complex onset: sC, t^hk, kk,

gn, mm, Ck sequences can either be shown to behave as heterosyllabic clusters (by the meter and reduplication tests) or fail to fit the general description of known onsets, which include only voiced stop - liquid, voiceless stop - sonorant. I will argue now that the deleted portions of the clusters in (28) cannot occupy a coda position either and that their loss is an instance of Stray Erasure.

5.3.2 The Minimal Sonority Difference in Attic

The cluster simplifications in (28) confirm one of the observations we made after considering the list of attested medial consonant sequences: only sonorant-stop clusters may precede an onset in word internal position. Moreover, the stop must be voiceless if preceded by a nasal. We see in (28) that consonant sequences which do not fit this description lose their second member: (28) attests not only the simplification of stop-s clusters, when followed by an onset but also that of sonorant-s, sonorant-z, s-stop, ng, geminate m and geminate s. Let us assume that all these are instances of Stray Erasure and that the lost C could not be syllabically incorporated. This means that what we have termed the non-onset clusters -- word initial sequences like s-stop -- cannot occur word medially unless each of their members belongs to a coda or an onset: s in /CV-grap^h -st^h ai/ is lost because it does not belong to an onset and, we must assume, because it cannot belong to the rime. Thus the assumption that Stray Erasure is responsible for all the consonant losses in (28) leads directly to the conclusion that medial clusters in Attic are sequences of codas and onsets.<11> Let us see then what (28) can tell us about the constraints on Attic codas.

First, the codas seem to be subject, like the onsets, to the Sonority Sequencing Generalization: we may attribute the loss of post-stop s to the fact that a stop - s coda will violate the SSG. Second, the simplification of geminates in what would have to be coda position indicates that there is a Minimum Sonority Distance requirement on tautosyllabic clusters. But there is still a residue of cases in which the lost consonant is not identical to the first and in which it is also of lower sonority.

What will explain its loss is the idea that the same version of the MDS which governs onset clusters also restricts membership in the coda: the ns, sk, ps, ng clusters which simplify are mirror images of the sm, ks, sp, gn non-onsets. The most significant fact we have uncovered in (28) is the contrast between p^h t^h enktos, syllabified

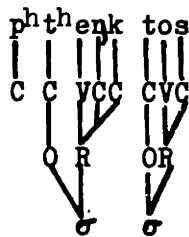

and /p^h t^h eng-mat/, syllabified



the difference between the members of this minimal pair parallels the difference between the tautosyllabic cluster in knep^has and the heterosyllabic initial in gnōmē. We can verify that all the mirror image clusters of the permitted onsets are attested as complex codas

by looking at the examples of r-stop and sonorant - voiceless stop in (30):

- (30) a. $\begin{array}{c} C \\ | \\ r \end{array}$ $\begin{array}{c} C \\ | \\ \boxed{\begin{array}{l} -son \\ -cont \end{array}} \end{array}$: e.derk^h.t^hen 'I was seen', smerd.nos 'power'
- b. $\begin{array}{c} C \\ | \\ [+son] \end{array}$ $\begin{array}{c} C \\ | \\ \boxed{\begin{array}{l} -son \\ -cont \\ -voice \end{array}} \end{array}$: e.melp.sa 'I sang', a.elp.tos 'unhoped for'
t^helk.tron 'charmed', p^ht^henk.tos 'uttered'
pemp.tos 'sent'

It is also possible to find the mirror image equivalent of the optional onset gl in the lg coda of eksemelgmenos 'pressed out (of milk)', syllabified ek.se.melg.me.nos.

We must now give a unified statement of the conditions under which pre- and post-nuclear clusters may be tautosyllabic: if we had considered before the possibility of listing the possible Attic onsets rather than deriving the list from a unique constraint, the prospect of having to repeat that list in mirror image disguise for the coda clusters should make it clear that an alternative solution is necessary.

The alternative has been discussed in Chapter 1 section 3.4; it consists of finding the right statement of the Minimal Sonority Distance requirement for Attic. Following in the spirit of the proposals made there, I give below the sonority scale of Attic which will make it possible to capture what the voiced stop - liquid, voiceless stop - nasal clusters and their mirror images have in common.

- (31) [-son,-cont,-voice] : p,k,t
[-son,-cont,+voice] : b,d,g
[-son,+cont,-voice] : s
[-son,+cont,+voice] : z
[+son,-cont,+nas] : m,n
[+son,-cont,-nas] : l,r

(31) shows that the sonority distance separating the tautosyllabic clusters bl and pn is a constant 4 intervals. Other permissible onsets are separated by at least 4 intervals. The heterosyllabic gn clusters are only 3 intervals apart. The same figures hold for the coda clusters. The MSD requirement in Greek is therefore 4 intervals and governs all tautosyllabic clusters.

- (32) Adjacent tautosyllabic consonants must be at least 4 intervals apart on the sonority scale.

We may leave it to the SSG to insure that the proper sonority profile is achieved within the syllable.

The rules which give rise to complex onsets and to codas in Attic may now be stated as in (34) :

(34) a. Onset Rule



b. Coda Rule



Both rules are iterative, both in the sense that they apply to as many skeleton sequences as meet their conditions on a given cycle, and in the sense that they may apply on the same cycle to their own output. Thus, we have no reason to believe that the complex coda in arktos 'bear' (ark.tos), an unanalyzable stem, has not been created in its entirety on the first cycle, by two successive applications of (34.b):

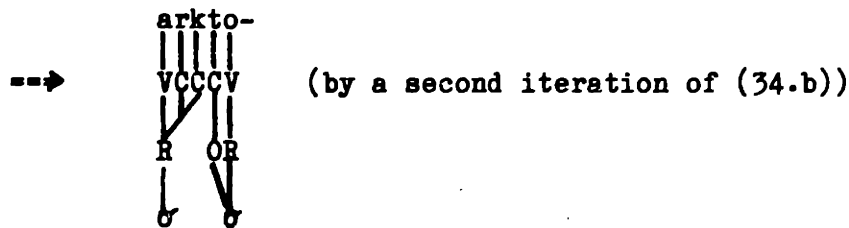
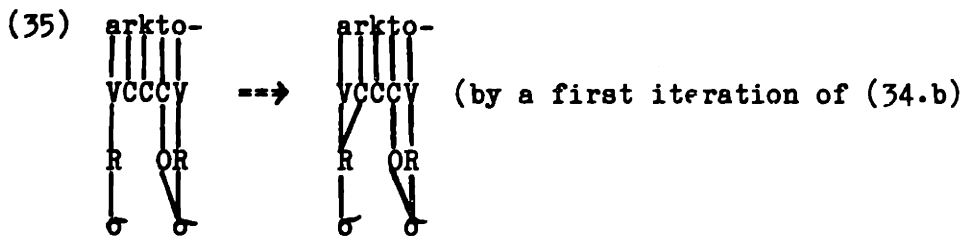

Notice now that we need not restrict the number of iterations of either (34.a) or (34.b): in other words, we need not stipulate how

many C's may be adjoined in the onset and in the rime. Condition (32) and the SSG will ensure that onsets and codas will consist of at most two C's: on the scale in (31) we cannot find a sequence of three entries each of which is separated by at least 4 intervals from the next.

The fact that the number of consonants in an Attic syllable is predictable from the MSD requirement is not accidental: a system of syllabification which includes a richer sonority table and a smaller MSD, that of Mycenaean and Sanskrit, will be seen to allow onsets like ksm and ktr derived by two iterations of (34.a).

Let us summarize what has been explained so far: the system of syllabification rules proposed here for Attic explains the pattern of cluster simplifications in (28) by invoking condition (32) whose formulation was made independently necessary by the investigation of Attic onset structure. It explains why some consonants are lost and, simultaneously, why they are lost in interconsonantal position. It also explains why there are at most two positions in an Attic onset or in an Attic coda. I take this to represent strong support for the program pursued in this section: that of attributing all CL-less consonant losses in Attic to the operation of Stray Erasure. We consider in the next section what assumptions are necessary in order to attribute the deletions in (29) to the same mechanism.

5.4 The Segmental Linking Condition

One of the trademarks of Ancient Greek is that no word ends in any consonant other than s, n, or r. The means by which this con-

straint on word final sequences is satisfied have been illustrated in (29.a-b): stem final k or t, if they end up in word final position, delete. There is no evidence on the behavior of other stem final stops, and of m or l. This section will offer an explanation for the attested loss of the word final stops, and this explanation will turn out to shed light on the apparently unrelated case of coronal stop deletion (/CV-komid-k-a/ => kekomika exemplified by (29.c). My suggestion will be that stops can be attached to a coda position only if they are segmentally linked to a following segment. I give below the schematic representation of segmentally linked matrices -- first introduced in Chapter 1, example (33).

(36) Linked matrices

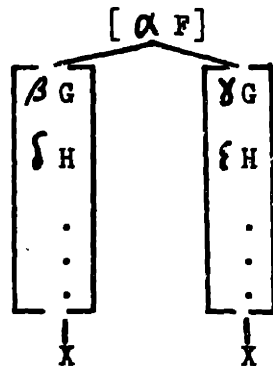

Representations like (37), in which the shared feature is autosegmentalized, also qualify as linked matrices:

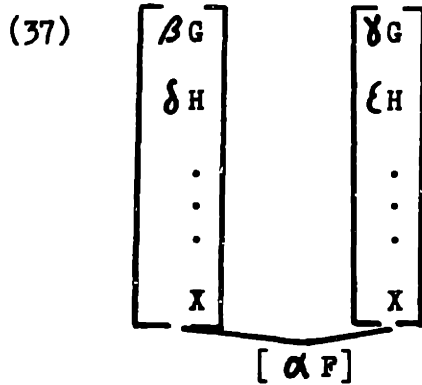

Relying on the existence of structures like (36) and (37) in Greek, I propose that the Coda rule (34.b) be supplemented by the following condition:

(38) Coda rule (revised)

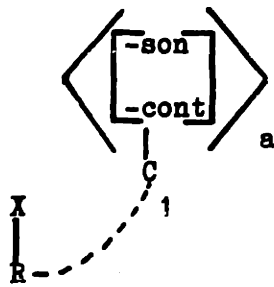

<C is segmentally linked to a following
₁
 position C and C is in the word tem-
₂ ₂
 plate.>
 b

a only if b.

We will see shortly what the word template is assumed to be.

Before we begin the case for (38), let me explain why it is not only desirable but also necessary to attribute the consonant losses in (29) to Stray Erasure. None of the cluster simplifications in (28)-(29) leads to CL. This is particularly significant in the case of consonants deleted in post-vocalic position, like /anakt/ → ana or

/CV-komid-k-a/ => kekomika. Suppose now (a) that the deleted kt or d in these examples could be syllabified; and (b) that they had been syllabified before being deleted. The input and output structures of deletion will then have to be as in (39):

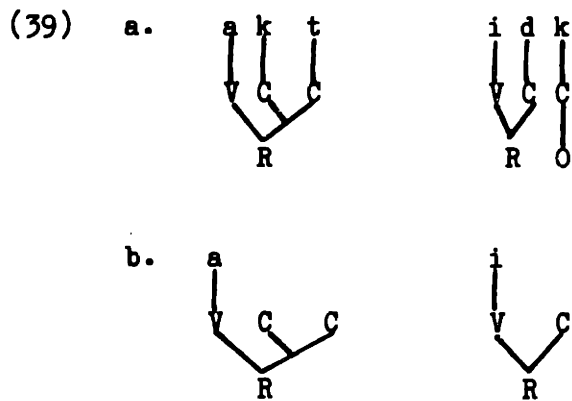

There is now way to block CL as formulated in (1), Chapter 2, from applying to such structures and from generating *anā, *kekomika. This means that at least one of the assumptions which led to (39) is wrong. Suppose that we abandon (b) and claim that the deleted consonants were, in principle, syllabifiable but had been eliminated before syllabification. Since the absence of dk or tk medial clusters and of final kt characterizes both tautomorphic and heteromorphic sequences in Attic the rule which deletes the relevant consonants must be postcyclic. By the previous argument, this postcyclic rule must precede syllabification. But this cannot be true, since we know that at least one cyclic consonant deletion rule does lead to CL and therefore follows syllabification. This is the post-sonorant s deletion which affects the aorist forms of sonorant -final verbal roots like p^ht^her 'to destroy', angel 'to announce': /V-p^ht^her-s-a/ 'I destroyed', /V-angel-s-a/ 'I announced' become ep^ht^hera, angēla after the

loss of s and the resyllabification, accompanied by CL, of the root-final consonant (cf. Chapter 2 section 4.2). The rule which deletes s in these aorist forms is cyclic: it does not apply morpheme internally in forms like arsēn 'male' (later Attic arrēn). Thus syllabification is cyclic and should feed any postcyclic rule or any convention activated by a postcyclic rule. Of the two assumptions we started with, it is now clear that (a) is wrong: the loss of kt and d did not lead to CL because these consonants could not be incorporated into syllabic structure. The same principle turns out to explain both the lack of CL and the consonant loss itself.

The initial indication that a segmental linking condition governs the syllabification of stops as codas comes from a comparison between the word final clusters which delete and those which do not. Consider the sequences -ks, -ps, -ns, -ls attested word finally (cf. 26.b-d). Some of these sequences violate the minimal distance requirement on tautosyllabic clusters; the first two are also violations of the Sonority Sequencing Generalization. They indicate that word finally s can occupy an extrametrical position in Greek. The corresponding word initial cases have already been observed in words beginning with heterosyllabic clusters like pt-, ps-, gn-, sk-, etc. Anticipating some of the conclusions of the next chapter, we state in (39) the dispensation which allows one word final s and one word initial consonant to surface without a position within the syllable:

(39) The word template of Greek

$$\begin{array}{c} [(C) \text{ o}^* (C)] \\ | \\ \underline{s} \end{array}$$

(39) says that a well-formed Greek word consists of a sequence of syllables and, optionally, of one word initial consonant and/or one word final s.

Returning now to the word final clusters we note that the stop undergoes, as in word medial position a rule of assimilation in voicing and aspiration. The stem final b of p^hleb- becomes voiceless, and, as we shall see, aspirated, by assimilation to the suffixal s in p^hleps (i.e. [p^hlep^hs]). A coronal stop like the stem final segment of k^harit- becomes a continuant when followed by another coronal, including the s of the NOM sg. The result, after voicing and aspiration assimilation, is k^hariss, later degeminated by the s-degemination rule ((25), Chapter 2) to k^haris<13>.

Thus, the word final clusters of (26.b-d) either contain a sonorant before s or contain a stop that shares voicing and aspiration with s or contain a geminate g. In all three cases (38) can apply to attach the first member of the cluster to the rime: the sonorants and s can be incorporated under any circumstances, whereas the stops meet the segmental linking condition of (38):

faces.

Turning now to the word medial deletion of a coronal stop illustrated in (29.c), we see that only an investigation of the segmental assimilation rules of Attic will determine whether the coronals in kekomidka, pepēt^hka, ēnutka were lost because they did not meet the segmental linking requirement of (38).

Such an investigation is also necessary to verify that other coda stops, like those of prag.ma, ep^h.t^hos, smerd.nos are in fact segmentally linked to a following slot in the word template.

This investigation follows in section 5.5. In the unmarked case I assume that any assimilation rule is an autosegmental operation and thus creates a cluster of linked matrices: the arguments for this have been given in Chapter 1, section 2.3. There will however be cases in which the evidence for autosegmental assimilation rules can be found in Greek.

5.5 Underlying clusters and segmental linking rules

5.5.1 Laryngeal Features Assimilation

The rule of Laryngeal Features Assimilation exemplified below in (42) is responsible for the surface generalization that obstruent clusters whose second member is a coronal have identical specifications for voice and aspiration.

- (42) a. kleb-dēn 'stealthily' : e-klap-ēn 'I was cheated'
 pleg-dēn 'entwined' : plekḡ 'to plait'
 tet^h lip-tai 'has been : t^h libḡ 'to squeeze'
 squeezed'
 lek-teos 'to be counted' : legḡ 'to count'
 strep-tos 'turned' : strep^h ḡ 'to turn'
 e-lek-to 'went to rest' : lek^h ḡ 'lay to rest'
 e-t^h lip^h -t^h ḡn 'I was : t^h libḡ 'to squeeze
 squeezed'
 lek^h -t^h ḡ-s-omai 'I will : legḡ 'to count'
 be counted'
 e-dok^h -t^h ḡ 'it seemed' : dok-e-ḡ 'to seem'
- b. pteruk-s 'wing-NOM' : pterug-os 'wing-GEN'
 t^h rik-s 'hair-NOM' : trik^h -os 'hair-GEN' <8>
 p^h lep-s 'vein-NOM' : p^h leb-os 'vein-GEN'
 strep-s-omai 'I will : strep^h ḡ 'I turn'
 turn'
 pos.si (eventually posi) : pod-os 'foot-GEN sg'
 'foot-DAT pl'
- c. komis-tēs 'one who takes : komid-ḡ 'care'
 care'
 At^h enās-de 'towards Athens' : At^h enās 'Athens-ACC pl.'
 buz-dēn 'closely' : be-bus-mai 'I have stuffed'

We observe that clear instances of voice and aspiration assimilation always involve [-sonorant] [-sonorant,+coronal] sequences. (On aspiration assimilation in stop-s clusters see below section 5.5.2.2). Other obstruent sequences (geminate like titt^hos, Bakk^hos; s-[-coronal])

sequences do not necessarily agree in aspiration or voice. The clearest case is that of the clusters spelled sb, sg (pelasgos, presbus). Sturtevant (1940:75) notes that in late Attic and hellenistic inscriptions the letter ζ which notes ordinarily the cluster zd, begins to replace σ before a voiced sound, as in πελαζγικόν (pelazgikon), ζμυρναῖος (Zmurnaios). Using ζ was a natural solution to the need for spelling [z] in contexts other than before d, once the need began to be felt. What is significant is that the ζγ - ζμ spellings are not attested earlier in Attic: either (a) the clusters spelled earlier σμ, σβ, σγ contained a voiceless s or (b) σ must have been doing double duty in spelling out both s and z and was replaced in the latter function by ζ in hellenistic times. I will argue in section (5.5.5) that in the few cases where a z needed to be spelled out in contexts other than before d the letter δ was used. Thus, I assign to spellings like ἐρδω, δάφουρος the value erzō, zaphouros. If so, of the alternatives listed above, (b) is false, which leaves us with (a): no voicing assimilation took place between [-sonorant] [-sonorant,-coronal] obstruent clusters. I give below the corresponding statement of LFA:

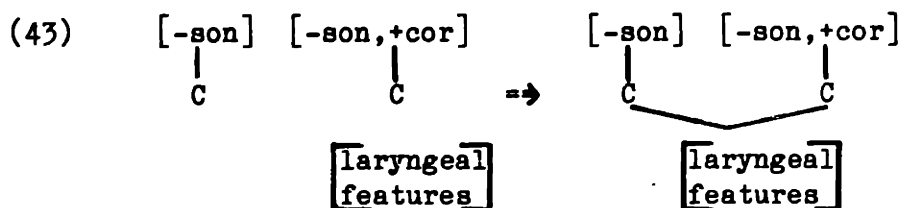

In (43) the laryngeal features component is shown to occupy a distinct tier of the representation: this property will be seen to characterize the matrix of all Greek stops, whose aspiration feature

is demonstrably autosegmentalized. Because LFA affects simultaneously voice and aspiration, I assume, without direct evidence to this effect, that the voicing of obstruents is also autosegmentalized, so that all laryngeal features are represented on a separate tier linked directly to the core.

The voicing and aspiration specifications of the obstruent continuants require comment: s will be shown to be aspirated but not linked to an aspiration autosegment. Rather, I will argue that the non-distinctive laryngeal specifications (like voicing and lack of aspiration for the sonorants, aspiration for s) are part of the melodic core. This being so, one may wonder how a rule formulated as LFA is in (43) can be applicable to the non-autosegmentalized aspiration of s. I assume that non-autosegmentalized features are simply a special case of features occupying a distinct tier: thus even though (43) mentions specifically a laryngeal feature component of the matrix which does not belong to the melodic core, it is in the limit applicable to the laryngeal features of obstruents like s, whose aspiration is in the core.

The evidence for an autosegmental representation of distinctive aspiration appears below.

5.5.2 The grammar of aspiration in Attic

Attic, like other Ancient Greek dialects, had in its surface inventory several aspirated consonants and aspirated vowels. For obstruent stops and for vowels the feature of aspiration was distinctive. S was, as elsewhere, redundantly specified as [+spread

glottis].

What this section seeks to establish is that consonant clusters agreeing in aspiration should be represented autosegmentally as

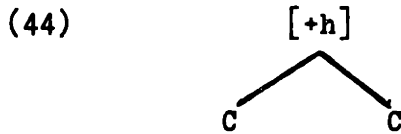

rather than segmentally, as

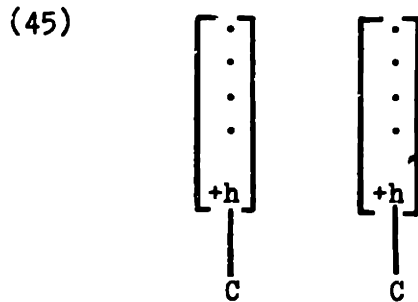

While the autosegmental format for partial assimilation rules is assumed in this chapter rather than shown to be necessary for each individual rule, specific arguments in its favor based on Greek evidence can be made. What follows is primarily an argument for the autosegmental representation of the feature of aspiration in stops. Having established this and relying on the assumption that agreement in an autosegmentalized feature is autosegmentally represented, we will be able to support (44) as the representation of obstruent clusters sharing aspiration.

5.5.2.1 Grassmann's Law

The Indo-European rule which deaspirates the first of a sequence

of two (not necessarily adjacent) aspirated stops was inherited into Attic in the following form: in a root containing two distinctively aspirated segments (two aspirated stops or an aspirated vowel and an aspirated stop) the first one loses its aspiration<14>.

Although aspirated, s does not participate in Grassmann Law (GL) alternations: thesaurus 'treasure', thrasus 'bold', thursos 'thyrsus', phusa 'pair of bellows', krusos 'gold' and many other similar forms show that s's aspiration does not act as a trigger for GL. I suggest that distinctive aspiration be represented on a separate autosegmental tier whereas the redundant aspiration of s be part of its main segmental matrix. GL will then delete the first in a sequence of two autosegments of aspiration.

GL did not apply when the second consonant did not belong to the root. Thus, preceding the suffixes -t^h_ē- (passive), -t^h- (present formant), -t^h_i (imperative 2nd. sg.) -t^h_{en} (ablative postposition), we observe the intact aspirated root consonants in e-k^hu-t^h_ē 'was poured', ōrt^h_ō-t^h_ē 'was set upright', e-p^han-t^h_ē 'was revealed', e-kat^har-t^h_ē 'was purified', p^hae-t^h_ō 'to shine', t^hale-t^h_ō 'to bloom', p^ha-t^h_i 'say', grap^he-t^h_i 'be written', strap^he-t^h_i 'turn about', t^heo-t^h_{en} 'from the gods', panta-k^ho-t^h_{en} 'from everywhere'.

GL is bled by a number of rules which deaspirate its potential trigger. Thus LFA and two assimilation rules that will be analyzed below -- Labial Assimilation (LA) and y-Assimilation (YA) -- turn sequences of aspirated stop-unaspirated consonant into an unaspirated cluster, making GL inapplicable in the forms below:

- (46)
- /^hek^h-ta/ => hekta (by LFA) 'properties'; cf. ek^h-q̄ 'to have'
 - /te-t^hrap^h-mai/ => tet^hrammai (by LA) 'I have fed'; cf. trep^hq̄ 'to feed'
 - /^hap^h-y-o/ => ^haptq̄ (by YA) 'to fasten'
 - /t^hak^h-yq̄n/ => t^hattq̄n (by YA) 'faster' (cf. tak^h-us 'fast').

GL is also inapplicable in the forms given in (47), where the second root aspirate is the first member of an aspirated [-son,-cor], [son,+cor] cluster,

- (47) a. t^hrik-s 'hair-NOMsg' (cf. trik^h-os 'hair-GENsg.)
 t^hrep-s-omai 'I will feed' (cf. trep^h-q̄ 'to feed')
- b. e-t^hrep -t^hq̄n 'I was fed'
 t^hrep -t^hq̄-s-omai 'I will be fed'

What I transliterated, following the traditional practice, as ks, ps, are clusters spelled out in early Greek as χσ, φσ (= k^hs, p^hs) and later, using a single complex sign, as ξ, ψ.

The interpretation of the p^ht^h, k^ht^h spellings like those in (78.b) was the subject of some debate. On grounds of articulatory plausibility, it was first suggested by Curtius (1879), most recently by Lejeune (1972), that φ^σ, χ^σ disguise deaspirated [pt'], [kt'] pronunciations. Curtius sought to explain in this way the failure of GL in et^hrep^ht^hq̄n and similar forms: et^hrep^ht^hq̄n would have been deaspirated to et^hrept^hq̄n before GL had had a chance to apply. The deaspirating effect of s on a preceding stop was never in doubt and, thus, the lack of GL effects in t^hriks, t^hrepsomai, was attributed to

a similar scenario: deaspiration of an aspirated stop by a following obstruent bleeds GL. This promising hypothesis makes it necessary to establish more clearly that the rule (43) (LFA) did have an aspiration assimilation component: the ϕ^h, χ^h spellings alone can no longer support that view.

5.5.2.2 Aspiration assimilation and Bartholomae's Law in Greek

The underlying sequence unaspirated stop - s - unaspirated consonant is not easy to come across in Greek. Instances of it are found in three morphological classes: (a) the past participle of the root h_{ep}s 'to boil', /h_{ep}s-to-s/, surface h_{ep}t^hos; (b) roots ending in a stop followed by the suffix -smo- or -smē-: /plok-smo-s/ 'locks' on plek 'to braid' surface plok^hmos; /rōg-smo-s/ 'cleft' on rōg 'to break' surface rok^hmos; and (c) the -skō presents of some stop-final roots: /pat^h-sk-ō/ 'to suffer' surface pask^hō; /lak-sk-ō/ 'to shout' surface laskō.

The last category involves a minor rule of metathesis which derives intermediate past^hkō, laskkō. On these representations a rule of aspiration transfer, similar to the one posed by Bartholomae for Indo-Iranian, applies, yielding past^hkō. After syllabification past^hkō, laskkō simplify to pask^hō, laskō<15>.

(48) Bartholomae's Law in Greek

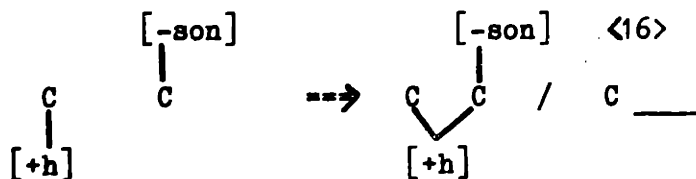

The restriction to clusters whose second member is an obstruent is probably predictable if Bartholomae's Law (BL) is a lexical rule, from the fact that there are no underlying aspirated sonorants in Greek. A structure preserving BL will be blocked from applying to create aspirated sonorants. The left environment of the rule is necessary in order to prevent it from applying to items like /pe-pē^h-ka/ 'I have persuaded' surface pepēka rather than *pepē(t^h)k^ha.

The rule of LFA, as originally formulated to apply to all clusters of the form [-son] [-son,+cor], is now sufficient, together with BL, to derive h_{ep}h_th_{os}:

(49) h_{ep}h_th_{os} 'boiled'

/h_{eps}-to-s/

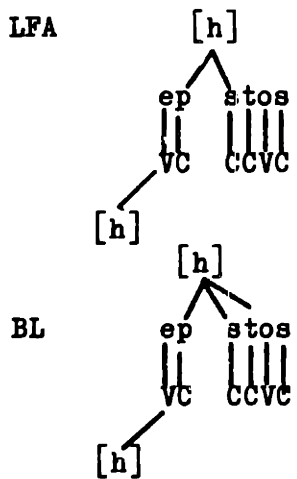

Note that the output of aspiration assimilation as applied to a stop-s cluster is a

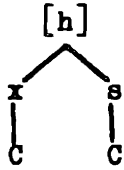

structure, with [h], the aspiration feature, represented as belonging to the melodic core, in accordance with our assumption that the aspiration feature of s is not autosegmentalized.

As in the case of the passive aorist and future forms et^hrep^ht^hēn, t^hrep^ht^hēsomai the cluster derived by BL does not trigger deaspiration in h^hep^ht^hos. The derivation of plok^hmos is identical, save for the inapplicability of BL.

5.5.2.3

Having shown that there are underlying clusters both of whose members are aspirated in the output of LFA, we can return to the main question of this section: how did GL fail to apply in et^hrep^ht^hēn, t^hrepsomai? There is a simple point that we should settle before we look into the phonetic value of the digraphs φθ, χθ, ψ, ζ : if it turns out that these stand for obstruent clusters whose first member was aspirated then our statement of GL will have to take this fact into account. But if it turns out that the pronunciation was [pt'], [kt'], [ps], [ks] then nothing really follows unless we also find out when the deaspiration has taken place. Only if the deaspirated pronunciations are shown to be correct and the deaspiration rule is shown to precede GL is the problem solved. Thus the question of whether it is possible to articulate two aspirated consonants in succession or whether the aspiration can be realized

without plosion is simply irrelevant here. If it is not possible to realize the aspiration in coda position it is still conceivable that deaspiration is a late process which does not affect GL.

The evidence concerning the phonetic value of $\phi\sigma, \chi\sigma, \psi, \xi$, is scanty but favors the view that both consonants were aspirated. First, the phonetic accuracy of the $\chi\sigma, \phi\sigma$ digraphs is vindicated by the observation made in Lejeune 1972 :73: when the sporadic metathesis of the $*\text{titk}\bar{\omega} \Rightarrow \text{tik}\bar{\omega}$ type occurred in a $[-\text{cor}, -\text{son}] \underline{s}$ cluster the output was invariably spelled out in the inscriptions as $\sigma\phi, \sigma\chi$ (= sp^h, sk^h). Lejeune cites ekalusp^hen (instead of ekalupsen) 'he covered' in an Eretrian 6th century inscription; sp^huk^hē (for psuk^he) 'soul' and eusk^hamenos (for euksamenos) 'praying' both from Attic inscriptions. This is significant because in prevocalic position the $\underline{p}^h, \underline{k}^h$ opposition was not otherwise neutralized in the spelling: sk^hetlios 'wretched' : skeuē 'preparation'; spērō 'to sow' : sp^heteros 'their own'. The aspirates of ekalusp^hen, eusk^hamenos cannot be explained unless the input to sporadic Metathesis were forms pronounced [ekalup^hsen], [euk^hsamenos] and thus corresponded to the archaic spellings $\phi\sigma, \chi\sigma$ of these clusters. From now on I will transliterate these clusters as p^hs, k^hs.

An indication that $\phi\sigma, \chi\sigma$ stood for diaspirate clusters is the notation of aspirated geminates in Greek: we find as a rule spellings like iakk^hē ἰάκκῃ, Bakk^hos, Βακκῶς Sapp^hē, Σαππῆ titt^hē τίττῃ, and we shall see that there is some independent support for a rule which deaspirates geminates. If $\phi\sigma, \chi\sigma$ are 'morpho-phonemic' spellings it is hard to see why the same spelling principle

was not applied to the geminates. A more general point is that, while one frequently finds spellings which reflect a relatively abstract level of representation, it is unprecedented, as far as I know, that a spelling system would selectively ignore the operation of an early rule (deaspiration in this case) while recording the effects of later rules like GL or like the rule which supplies all word initial u's with aspiration. This rule is even later than GL itself, as forms like

h h up ainā 'to weave', h h ut los 'nonsense' indicate, yet its effect is faithfully recorded.

Thus, to the extent that there is any data on the phonetic values of the *ph*, *χp*, *ψ*, *ξ*, digraphs, it supports the view that both obstruents were aspirated. This fact is of considerable interest, since it eliminates an easy answer to our question: why GL failed to apply in et^hrep^ht^hān and t^hrepsomai, or rather, t^hrep^hsomai.

I suggest that the correct answer is to be found in the analysis of forms where GL is apparently blocked by an intervening boundary<17>. These forms require a statement of the rule which specifies that both aspiration autosegments which enter the rule must belong to the root morpheme. On the other hand, GL appears to be blocked by phonological processes that are triggered by some level 2 suffixes (t^hram-mai from underlying /te-t^hrap^h-mai/ and similar forms cited below in the discussion of Labial Assimilation). This last fact, a potential problem for any version of the strict cycle, can be explained by requiring that the trigger of GL be an aspiration feature linked to an onset C :

(50) Grassmann's Law

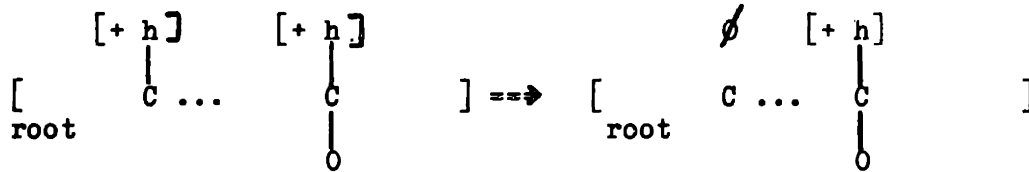

Before suffixes are added, the syllabic status of the second aspirated segment in a diaspirate root (t^hrep^h, t^hrik^h, t^hrup^h, h^hap^h, h^hek^h) is certainly not that of an onset. If a vowel initial suffix is added to the root then the final aspirated stop becomes an onset and the rule can apply: t^hrik^hos, after the addition of the level 2 GENsg. suffix -os, is syllabified

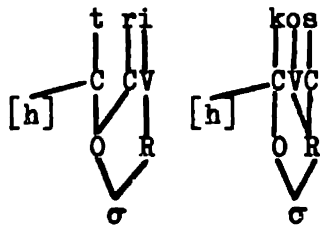

and turned into

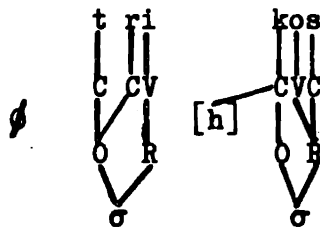

by GL. At level 1 too, addition of a sonorant initial suffix will produce the same syllabification: the derivational suffix -ro- added to the root t^hap^h 'to dig' produces

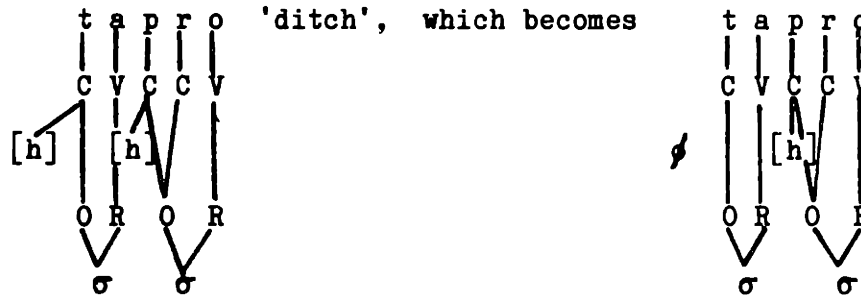

by GL, eventually tap^hros. /t^hrup^h-ero-s/ 'delicate' yields trup^heros in the same way. In these two cases, GL is met at level 1, after the derivational suffixes -ro-, -ero- are added, and it applies then. In the case of trik^hos, GL is met, and applies, at level 2. In tet^hram-mai and h^hekta, no suffixes are added at level 1; as a result GL cannot be met and fails to apply; at level 2 the inflectional suffixes -mai, -to- are added; they trigger LA and LFA, which eliminate the aspiration of the root final stop and bleed GL.

We had to assume that the trigger of GL is an onset aspirated stop in the root in order to avoid applying GL in violation of the strict cycle principle. The formulation of GL dictated by these considerations will also fail to apply to et^hrep^ht^hen and t^hrep^hsomai even if the input to GL contains aspirated clusters. Deaspiration will fail to be triggered by the root final aspirate because it is not attached to an onset at any level; the suffix initial t^h in et^hrep^h-t^hen will not condition GL because it does not belong to the root.

The lack of aspiration in the reduplicating syllable of aspirate initial verbal roots is unanimously attributed to GL (for example Lejeune 1972 : 56, Smyth 1976 : 31). Pe-p^heug-a 'I have fled', te-

t^hn̄gy-ka 'I have died', kə-k^hu-mai 'I am absorbed' are said to have been derived from p^he-p^heug-a, t^he-t^hney-ka, k^he-k^hu-mai through the deaspiration of the initial stop. The analysis of Greek reduplication proposed here is incompatible with such a view. The representation of pe-p^heug-a, for example, should be, if we ignore the root initial aspiration,

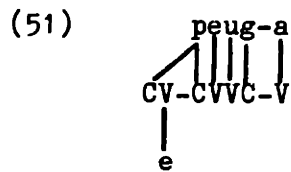

The initial stop in the reduplication syllable is the same as the root initial stop. There can be no question of one deaspirating the other. And even if the CV slot in the reduplicating unit had been given its segmental content through copying rather than direct linking to the root melody, GL could still not deaspirate the reduplication prefix: as we have seen, GL applies only within the confines of the root. Thus, not only the particular analysis of perfect reduplication adopted here, but any analysis which maintains Marantz's basic insight that reduplication is a special case of affixation, will attribute the deaspirated initial of pe-p^heug-a to a different cause from Gl.

It turns out that an autosegmental analysis of aspiration has a choice of answers to this question. The most elementary solution is to assume that the deaspiration rule required for 'adjacent' geminates in Bakk^hos, Sapp^hō applies to all geminate clusters:

(52) Geminate Deaspiration

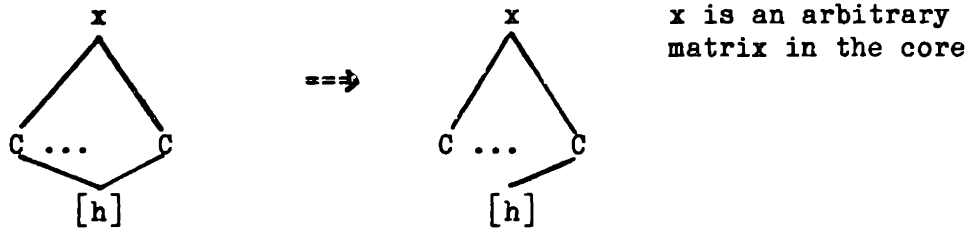

(52) will apply to pe-p^heug-a as it will apply to Bakk^hoe:

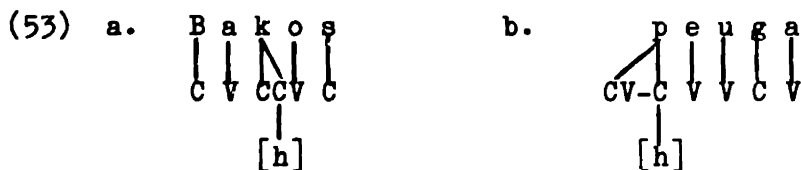

Note that the autosegmental statement of the rule is possible only if the aspiration feature is represented as linked directly to the C slots rather than associated with the rest of the segmental matrix and, indirectly, to the skeleton, as in (54):

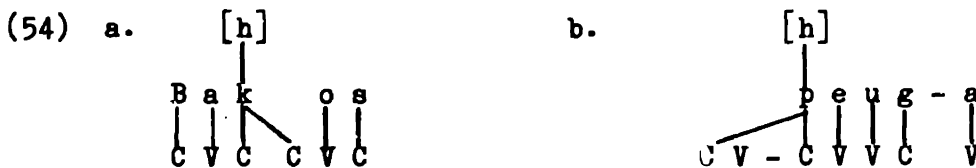

It is difficult to see how a Geminate Deaspiration rule could affect representations like those in (54).

This example suggests that the content of the informal notion of autosegmentalization used so far is the property of direct association to the core. A non-autosegmentalized feature is one which is linked to the core indirectly as part of the main segmental matrix. Direct

association of a feature to the skeleton entails that the feature in question occupies a different tier of the phonological representation, although the converse does not hold, as (54) shows.

Having made precise what Geminate Deaspiration entails for the autosegmental analysis of aspiration in Greek, one becomes aware that the linking of the reduplication C to the segmental matrix of the first root onset need not be accompanied by linking to the aspiration autosegment. The only point of contact between segmental matrix and aspiration is the core C: the fact that the reduplication rule requires linking to the former does not mean that an association to the latter must also be established. If in fact only the melodic core is linked to the reduplication C, we obtain from the beginning a deaspirated stop in pe-p^heug-a:

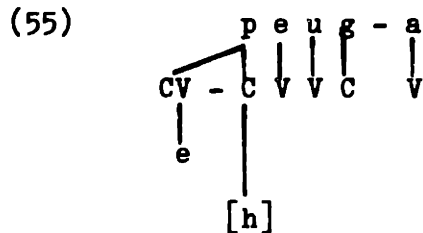

The analysis of reduplication based on Geminate Deaspiration differs in some testable respects from the one sketched in (55) but the relevant forms are few and open to a number of interpretations.

My immediate concern was to support an autosegmental analysis of aspiration in Greek, which would in turn entail that rules of aspiration assimilation like LFA are autosegmental operations. Let me sum up what conclusions can be drawn in this respect from the previous discussion. We have established in (5.5.2.3) that g acts as an

aspirated segment with respect to LFA in providing the source for the surface aspirates in ep^ht^hos, plok^hmos. Nonetheless s does not participate in GL, a fact which we have attributed to its lack of autosegmentalized aspiration. The proper statement of GL, as given in (50), involves reference to adjacency on the [+spread glottis] tier: I submit that only an autosegmental analysis of distinctive aspiration can dispense with the use of variables in the statement of the rule. Second, the analysis of reduplication defended on other grounds in section (4) requires separating the aspiration feature of stops from their main segmental matrix. Two autosegmental explanations have been offered for the deaspirated initials of reduplicated perfects like pe-p^heng-a. While the choice between them may be made difficult by the lack of clear data, they share the important feature of requiring a separate linking between that feature and the skeleton. It is worth stressing that only an autosegmental view of aspiration is compatible with the correct analysis of reduplication.

We may add to the list of arguments supporting an autosegmental rule for aspiration assimilation the need for a rule like h-Reassociation ((44) in Chapter 2). Recall that this rule, repeated below in (56), provides the input to LFA in phrases like nuk^ht^holēn from nukta^holēn 'whole night-ACC':

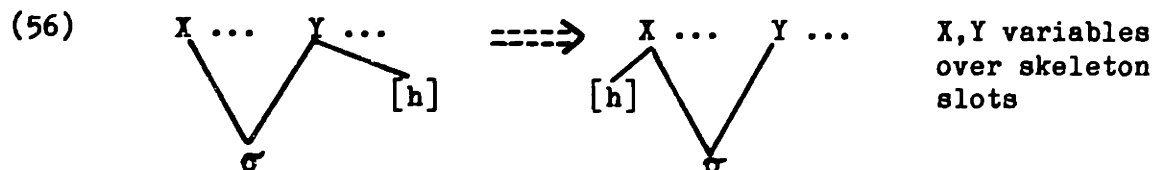

As we mentioned in Chapter 2, the rule will be unstateable without the

assumption that aspiration is autosegmentalized. The aspiration element displaced by (56) is the trigger of LFA in nuk^ht^holēn: since the trigger is an autosegment it is natural to assume that LFA consists of association to the autosegment (as in (43)) rather than of copying it (as in (43')):

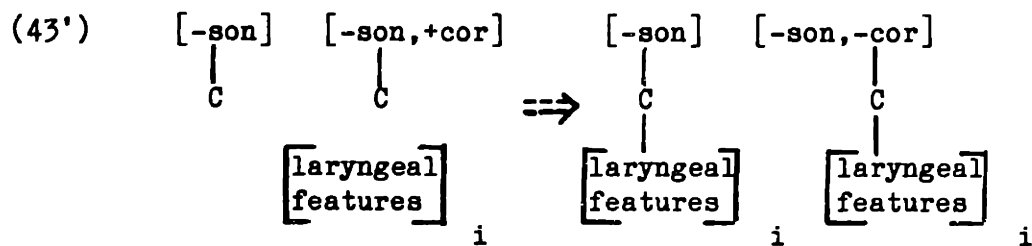
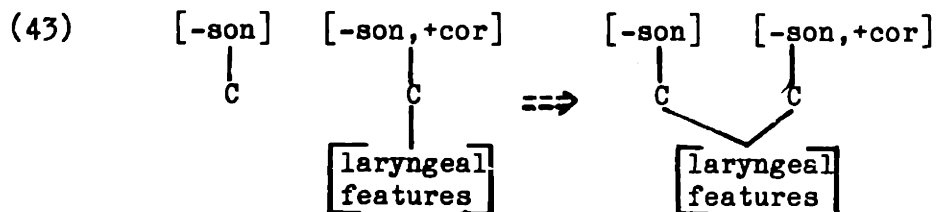

5.5.3 Coronal Clusters

Certain surface st, sth clusters, like those in komis-tes 'one who takes care of', skeuas-t^hē-s-omai 'I will be made ready', korus-tēs 'man with a helmet' result from underlying sequences of two coronal stops: /komid-tes/, /skeuad-t^hē-/ , /korut^h-tēs/ (cf. related forms komidēs, korut^h-os, e-skeuad-atai). The relevant rule can be stated

$$(57) \quad [-son,+cor] \implies [+cont] / \implies [-son,+cor]$$

In conjunction with LFA, (57) will derive komistēs and korustēs as shown below:

- | | | | |
|---------|---------------|----|-----------------------------|
| (58) a. | komistēs | b. | korustēs |
| | /komid-tēs-s/ | | /korut ^h -tēs-s/ |
| (57) | komiz tēs | | korus tēs s |
| (LFA) | komis tēs | | korus tēs s |

One class of coronal clusters, underlying t, t^h, d followed by s yield in Attic a surface single s: underlying /pod-si/, /ornit^h-si/ become surface posi, ornisi. Their derivations, involving rules by now familiar, are given in (59):

- (59) a. posi 'feet-DATpl.' b. ornisi 'bind-DATpl.'
- /pod-si/ /ornith^h-si/
- (57) poz si ornisi si
- (LFA) pos si ornisi si
- (Degemination) posi ornisi

Recall that we explained why the rule of Degemination, first introduced in (24) Chapter 2, does not lead to CL by assuming that the geminates subject to it are merged matrices, as in (60), rather than unlinked matrices, as in (61):

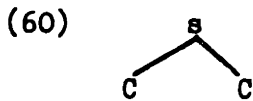

Since Degemination applies to the derived geminates of intermediate possi, ornissi without CL effects, it must be that those derived geminates are structures like (60). Our autosegmental statement of LFA actually predicts this: the output of LFA as applied to /pod-si/ and /ornith^h-si/is, in autosegmental notation,

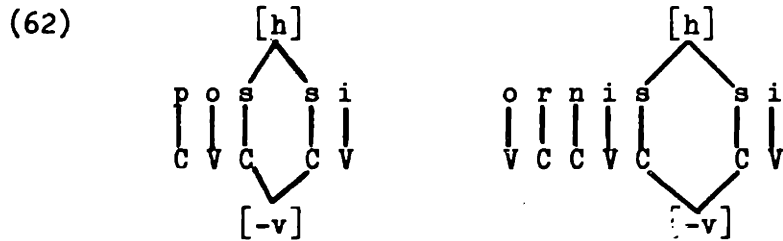

where s stands for the complex of supralaryngeal features
 [son,+cont,+cor,...]. The representation in (62) qualify for the
 Shared Feature Convention (cf. (39), Chapter 1) and consequently
 become

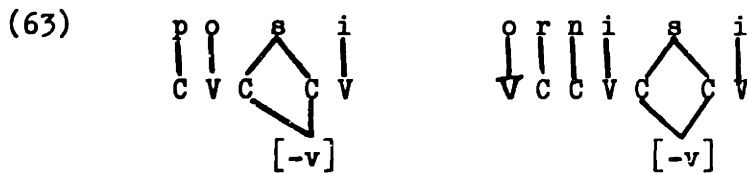

Degemination applies by deleting one of the C slots associated with s
 and we obtain

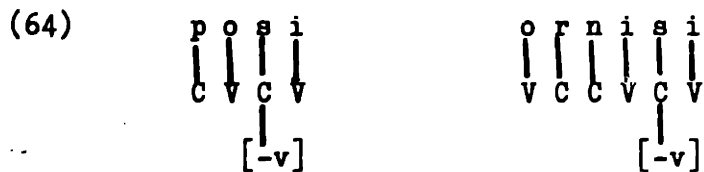

Note that what made the Shared Features Convention applicable in (62)
 was the segmental link created in the melodic core by the application
 of LFA to the aspiration feature of s: had s's aspiration been
 represented as autosegmentalized

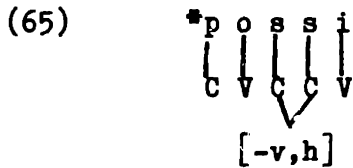

the Shared Features Convention would have been inapplicable and we would not have been able to account for the fact that the output of (57) and LFA in /pod-si/ is a true geminate s.

We may add the interaction between (57), LFA and Degemination to the list of arguments that partial assimilation rules are autosegmental operations.

5.5.4 Labial Clusters

Many of the verbal endings begin with m: 1st. sg. middle primary -mai, 1st. pl. active -men, 1st. pl. middle -met^ha, middle participle -meno-. Before these endings a stem final labial consonant becomes the first half of a geminate m. The rule extends beyond the verbal system (cf. /op-mat/ => omma 'eye', /pro-grap^h-mat/ => programma 'edict', /apo-t^h lib-mos/ => apot^hlimmos 'oppression') and eliminates in fact all underlying [+labial] m clusters. The statement of labial gemination can take the form in (66):

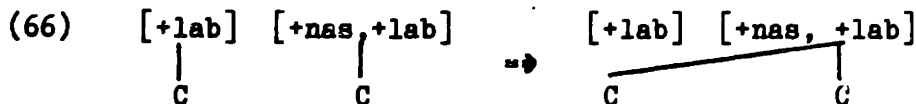

But our previous discussion has opened up the possibility of writing rules whose eventual output are true geminates as partial assimilation rules. This is possible again in the case of labial gemination as

(67) demonstrates:

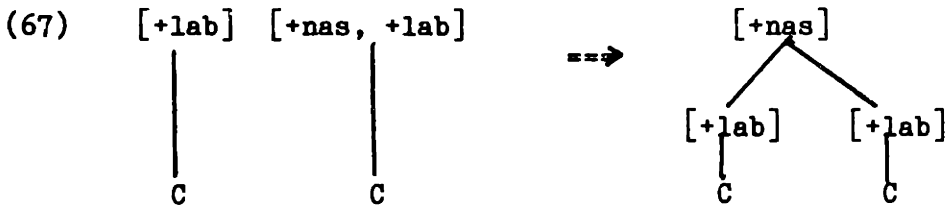

(We can assume that the specification [+nasal] implies [-spread glottis, +voice, +son] at least within the Attic phonemic inventory: these specifications will consequently not be added in (51)). The immediate output of (67) is subjected to the Shared Features Convention to yield the true geminate structure in (68):

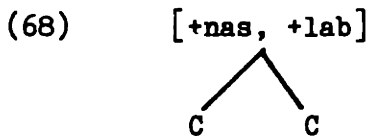

Before making a choice between (66) and (67) as statements of Labial Gemination let us consider another type of assimilation involving labial consonants: b becomes m before a following n:

- (69) a. /seb-nos/ => semnos 'venerable' ; sebomai 'to worship'
 /ereb-nos/ => er-mnos 'murky' ; Erebos
- b. *ag^wnos => *abnos => annos 'lamb'
 *g^wnā- => *bnā- => mna-omai 'to get married'

One can add to these traditional examples limnē 'lake, a pool of standing water' on the root lib of lēbō 'to pour'. The primary justification of a rule turning bn into mn as a synchronic rule lies how-

ever in the absence of surface bn sequences. The rule could be stated as in (70):

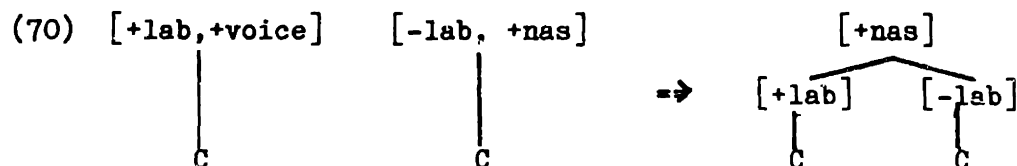

There is a striking similarity between (70) and the version of Labial Gemination given in (67). Both rules assimilate in nasality a sequence of labial stop - nasal. A unified statement of the two phenomena should take the form of (71) below, a simpler rule than either (66), (67) or (70) taken separately:

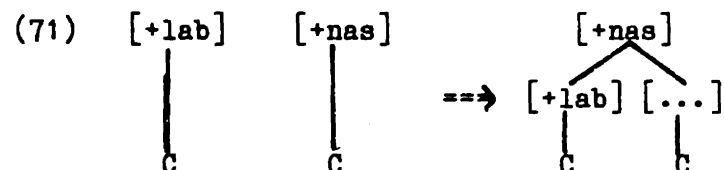

The difficulty faced by (71) is that it will also apply, incorrectly, to pn, p^hn clusters, yielding, say, *mneḡ for pneḡ, *Damnḡ for Dap^hnḡ etc. Let us then assume for the sake of maintaining (71) that it applies after syllabification, or at least after the rule determining onset structure, and that it requires heterosyllabic segments:

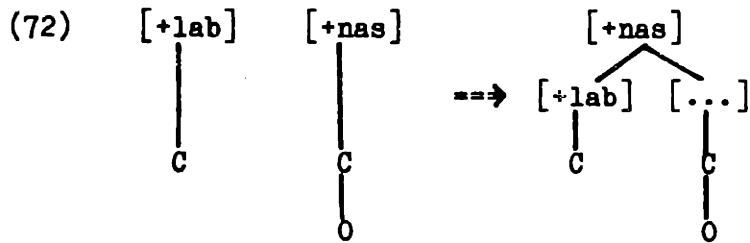

Since pn and p^hn are the only known tautosyllabic clusters among [+lab] [+nas] sequences (72) will not apply to them.

Before an m, d becomes s in Attic. While other segmental rules discussed here are shared by Attic with other dialects the sm clusters resulting from underlying dm do not appear in either Ionian or Aeolic.

(73)

id-men 'we know' (epic, Ionian)	:	is-men Attic (id-ēn 'to know')
od-mē 'scent' (epic, Ionian)	:	os-mē Attic (od-ōd-a 'I have smelled')
		erēs-mai Attic (erēd-ō 'to prop up')
a-dmē-tos 'untamed' (epic)	:	Asmetos Attic<18> (damazdō 'to tame')
Admetos		
pe-p ^h rad-menos 'shown' (epic)	:	pe-p ^h ras-mai Attic (p ^h razdō 'to show')
p ^h rad-mo-sunē 'understanding'	:	p ^h ras-mo-sunē Attic
		klus-ma 'drench' (kluzdō 'wash over')
		klud-ōn 'wave')

Alternations like kluzdō : klusma, kekklusmai are widespread in Attic, where the present stems in d-yo ==> zdō are highly productive.

A first approximation of the rule responsible for ismen, klusma is (74):

(74) [-son, +cor, +voice] ==> [+cont, -voice] / ___ [+lab, +nas]

The absence of dm clusters in Attic, be they hetero- or tauto-morphemic, seems to indicate that the rule is postlexical since it is feature changing and it must be allowed to apply in derived as well as non-derived environments.

A rule very similar to it, which affects all coronal stops rather than just d appears to apply before the m of the inflectional morphemes only and before the derivational suffix -mat-, a level 2 suffix. This process is illustrated in (75) below:

(75) pe-pus-menos 'having found out' (pu-n-t^h-an-omai, peut^h-omai)
 pe-pēs-mai 'I have persuaded' (pēt^h-ō)
 ānus-mai 'I have accomplished' (anut-ō)

In contrast with the inflectional endings, the level 1 derivational endings have no effect on a preceding voiceless coronal:

(76) keut^h-mōn 'hiding place' : keuth^h-ō 'to hide'
 eret-mon 'oar' : erett-ō 'to row', eret-ēs 'rower'
 pot-mos 'fate, that which : pi-pt-ō 'to fall'
 befalls one'

Morpheme internally the tm, t^hm clusters are also preserved intact: arit^hmos 'number', put^hmōn 'bottom', ar-t^hmos 'bond' (on the root ar of arariskō 'to fit together').

The rule responsible for the alternations in (75) could be stated as in (77):

(77) [+cor, -son] ==> [+cont] / ___ [+lab, +nas]

To constrain the application of (77), we can consider it a cyclic rule. But its similarities to the more restricted, postcyclic rule in (74) turn out to be more extensive than first thought: Homer's dialect lacked not only (74) but, in all likelihood, (77) as well: one finds forms like ēl-ēlot^h-men 'we had gone' (A 151, g 81), e-pe-pit^h-men 'we had persuaded' (B 341), ke-korut^h-menos 'furnished with a helmet' (G 18, Ps 111). The frequently encountered forms in sm (pe-pus-mai 1505, le-las-met^ha 'we have escaped' L 313, le-las-menos 'forgotten' P 538 etc.) can be ascribed to the tendency to Atticize the text wherever this did not interfere with the scansion: in this case, replacing tm, t^hm with sm did not, since all three clusters were, like all consonant clusters, counted as heterosyllabic in the Homeric prosody. The coexistence of pep^hradmenos, idmen, Admetos with ēlelōt^h-men, epepit^hmen, kekorut^hmenos in the Homeric dialect suggests that the formal similarities between (74) and (77) are not coincidental. It is possible to eliminate (74) altogether and let (77) alone derive in Attic pepēsmai as well as pep^hrasmenos, p^hrasmosunē and osmē, if the tm, t^hm clusters of eretmon, keut^hmōn can be exempted from the operation of the rule. We note that, once again, the clusters which fail to undergo the rule in non-derived environments are onset clusters (tm, t^hm). The cluster which undergoes the rule in derived as well as underived environments is the non-onset clusters dm. The obvious hypothesis is that (77) is syllable-dependent in the same way

as Labial Assimilation (72):<19>

(78) [+cor, -son] ==> [+cont, -voice] / $\begin{array}{c} \text{---} \\ | \\ \text{c} \end{array}$ [+lab, +nas] $\begin{array}{c} | \\ \text{c} \\ | \\ \text{O} \end{array}$

It remains to be explained why, across an inflectional boundary, all [coronal] m clusters count as heterosyllabic from the point of view of (78). The details of the explanation will not become clear before section (6) but the general idea is that the level 2 inflectional boundary prevents the syllabification of the root final coronal as the first element in a branching onset tm, t^hm. Assuming for the moment that the root final coronals are syllabified as codas at the end of the first cycle in p^hrad and p^het but that the derivational suffixes -mē- and -mo- do not define cyclic domains, we can see syllabification and cyclic applications of (78) interact as below:

(79)	osm̄ē	eretmos	pep ^h rasmai	pep̄smai
Level 1	odme	eretmo	p ^h rad	pet ^h
Syllab.	VCCVY	VCVCCV	C CVC	CVCC
	R OR	RORO R	O R	O R
	σ σ	σ σ σ	σ	σ
(78)	osme	_____	_____	_____
Level 2				
Syllab.	_____	_____	p ^h rad-mai<20>	pet ^h -mai<20>
			C CVC CVV	CVCC CVV
			O R O R	O R OR
			σ σ	σ σ
(78)	_____	_____	p ^h ras-mai	pes -mai
			C CVC CVV	CVCC CVV
			O R O R	O R OR
			σ σ	σ σ

The m-initial endings of the verbal morphology also provide the environment for a rule affecting velar stops: velars become voiced and unaspirated before an m-initial inflectional suffix and before the derivational suffix -mat- :

(80)	te-teug-mai 'I have happened to'	:	te-tuk ^h -a 'id'.
	de-dē g-mai 'I have been shown'	:	dēk-nū-mi 'to show'
	de-deg-mai 'I have received'	:	dek ^h -omai 'to receive'
	pe-pleg-mai 'I have woven'	:	plek-o 'to weave'
	ēug-mai 'I have prayed'	:	euk ^h -omai 'to pray'
	prāg-ma 'deed'	:	pratt-ḡ 'to do' (root prak ^h)
	para-dēg-ma 'model'	:	dēk-nū-mi 'to show'

The rule can be stated as:

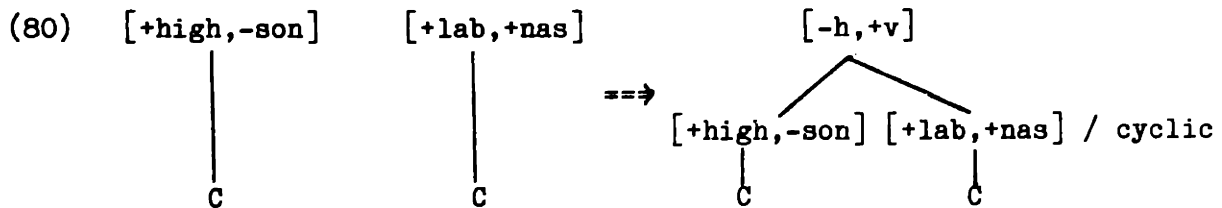

but, if advantage is taken of the heterosyllabicity condition which governs (78) and (72), one can also write:

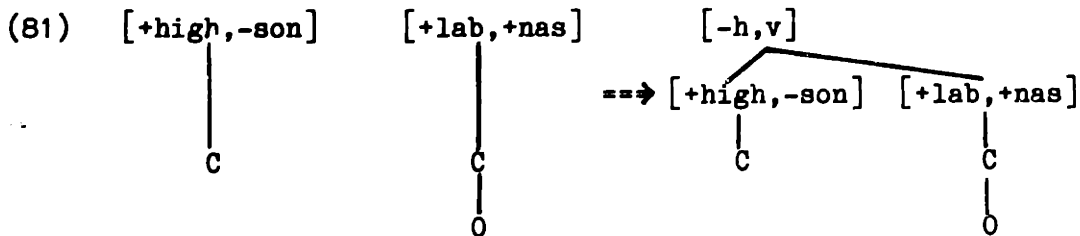

which will allow the rule to apply to tautomorphic or tautocyclic velar-m clusters that are heterosyllabic: agmos 'broken cliff', stigmē 'brandmark', pugnē 'fist'. These are all underlying gm clusters whose related roots appear in agnūmi 'to break', stizdō (root stig) 'to tattoo', pugē 'rump'.

Once the heterosyllabicity condition is imposed on (81) we can simplify the rule considerably: any heterosyllabic stop-sonorant cluster may undergo voicing and deaspiration as stipulated in (81) because the only surface voiceless or voiceless and aspirated stops which precede a sonorant are the obligatory tautosyllabic sequences stop-r, voiceless stop - nasal. Thus nothing prevents us from replacing (81) with (82), a rule of far greater generality:

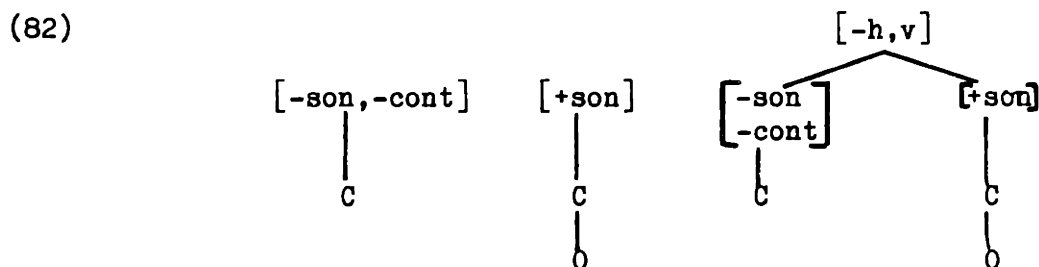

The effect of (82) will be segmentally vacuous for all but the velar - nasal clusters in (80) because all but those heterosyllabic clusters already contain a voiced deaspirated stop. But (82) will leave its mark - segmental linking - on all sequences to which it applies: in its output, forms like stigmē will look as below:

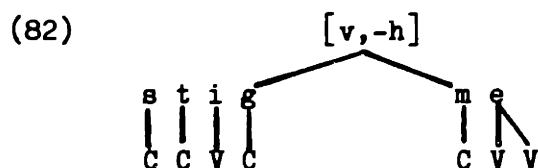

There are advantages to generalizing this voicing and deaspiration rule as in (82) that go beyond the elimination of some feature specifications. We shall explore them in section (5.7).

5.5.5 Y-Clusters in Attic

In the general case high vowels remain syllabic in all environments in Greek. Thus, unlike in Latin, prevocalic i, u even in word initial position maintain their syllabicity:

- (84) iain̄ 'to cheer' syllabified i.ai.n̄
 iapt̄ 'to shoot' syllabified i.ap.t̄
 iaomai 'to heal' syllabified i.a.o.mai
^huaina 'hyena' syllabified ^hu.ai.na
^huetos 'rain' syllabified ^hu.e.tos

Postvocalic high vowels are syllabified as part of the first nucleus, as the facts of meter and accentuation show

- (85) oiomai 'I think' syllabified oi.o.mai
 auos 'dry' syllabified au.os
 euk^homai 'I pray' syllabified eu.k^ho.mai

Earlier in the history of Greek, high vowels could occupy C positions. A complex of sound changes, some of which left no imprint on the synchronic phonology of Attic, altered this state: an onset y became h in syllable initial position and h was frequently lost without trace. Postconsonantal y, syllabified earlier as the second member of a branching onset, entered a series of complex assimilation rules with a preceding stop. When preceded by a postvocalic sonorant y metathesized with it, as in p^hanȳ → p^hain̄, morya → moira, examples discussed briefly in Chapter 2 above. The metathesized y is treated in Ionic-Attic as the second member of the nucleus, i.e., like

the postvocalic i of oida 'I know', etc. I shall discuss here the assimilation rules which affect stop-y clusters. They involve a segment which, from the point of view of 1st millenium Greek, is exceptional:

$$\begin{array}{c} i \text{ (= y)} \\ | \\ C \end{array}$$

This segment must be posited in the underlying representations of the feminine suffix -ya- of morya => moira, and the comparative suffix -yon-/-yos- of k^heryōn 'worse' => k^heirōn => k^hērōn, amenyōn 'better' => ameinōn => amēnōn.

Certain elements of the evolution of stop-y clusters are shared by all such sequences: y becomes a coronal obstruent; the entire cluster takes on the voicing feature of its first member and the lack of aspiration of y:

- (86) a. k-y : /k^heruk-y-ō/ => k^herussō, k^heruttō in Attic 'to herald'
'(cf. k^heruk-os 'herald-GEN')
- b. k^h-y : /tarak^h-y-ō/ => tarassō, tarattō in Attic 'disturb'
- c. g-y : /^hag-y-onai/ => ^hazdomai 'stand in awe' (cf. ^hagnos 'holy')
- d. p-y : /astrap-y-ō/ => astraptō 'to hurl lightnings' (cf. astrapē 'lightning')
- e. p^h-y : /bap^h-y-ō/ => baptō 'to submerge' (cf. bap^hē 'dye')
- f. t-y : /eret-y-ō/ => eressō, erettō in Attic
'to row' (cf. eretes 'rower')
- g. t^h-y : /korut^h-y-ō/ => korussō, koruttō in Attic 'to equip'
(cf. korut^h-os 'helmet-GEN')
- h. d-y : /komid-y-ō/ => komizdō 'to provide'
(cf. komidē 'supplies')

But, as the examples above show, beyond the voicing, aspiration and obstruency assimilation, the treatment of various stop-y groups diverge. In labial - y clusters the coronal obstruent replacing y becomes a non-continuant, therefore a coronal stop, while elsewhere it inherits the [+continuant] specification of y. Velars followed by y become coronals and afterwards share the fate of underlying dentals: in a voiced cluster the dz sequence (derived by the voicing and aspiration assimilation of dy and by the obstruentization of y) undergoes continuancy metathesis and yields zd. Elsewhere the first member of the cluster becomes a continuant. The required sequence of rules is given in (87), with their application illustrated in (88):

(87) Y-Assimilation

a. $[-\text{son}, +\text{high}] \Rightarrow [-\text{high}, +\text{cor}] / __ [-\text{back}, +\text{son}, +\text{high}]$

$\begin{array}{c} | \\ \text{C} \end{array} \quad \begin{array}{c} | \\ \text{C} \end{array} \quad \begin{array}{c} | \\ \text{C} \end{array}$

b.

$\begin{array}{c} [-\text{son}] \\ | \\ \text{C} \\ | \\ [\alpha \text{ voice}] \end{array} \quad \begin{array}{c} [-\text{h} \\ -\text{back} \\ +\text{son} \\ +\text{high}] \\ | \\ \text{C} \end{array} \quad \Rightarrow \quad \begin{array}{c} [-\text{h} \\ -\text{son}] \\ / \quad \backslash \\ [\dots] \quad [-\text{back} \\ +\text{hi}] \\ | \quad \quad | \\ \text{C} \quad \quad \text{C} \\ \backslash \quad / \\ [\alpha \text{ voice}] \end{array}$

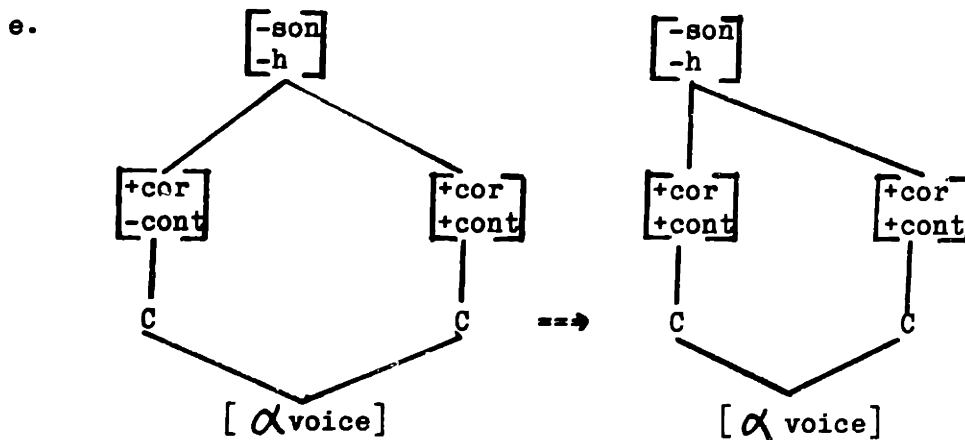
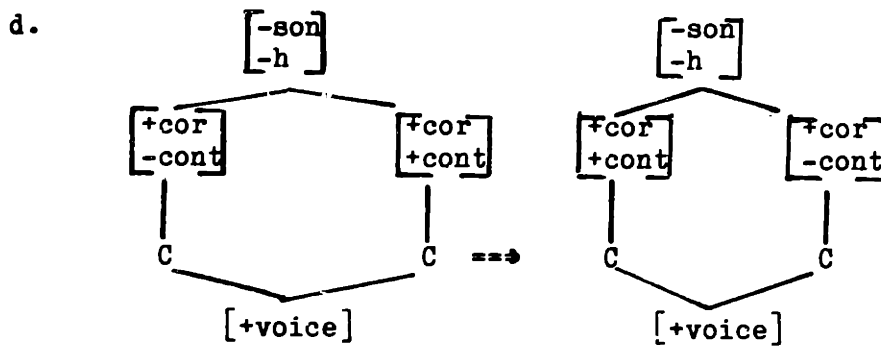
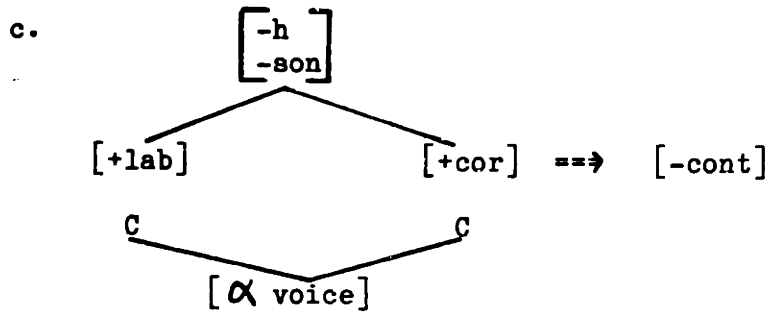

Insert table I

A less conservative interpretation of the phonetic value of Greek ζ could make rule (87d), the continuancy metathesis, unnecessary: we could assume that ζ stands for a cluster like the one in (89), where the continuancy of the second member is unspecified, thus either minus (in zd) or plus (therefore zz).

Table I

/tarak^h-y-ō/
tarat^hyō

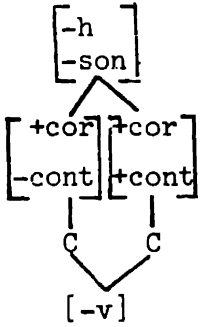

n/a

n/a

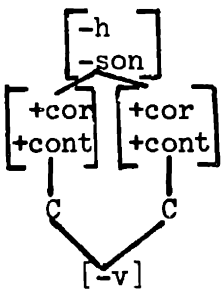

· /^hag-y-o-mai/
^hadyomai

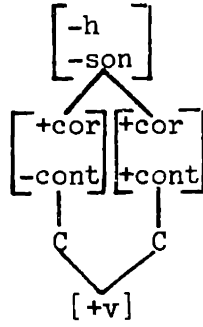

n/a

n/a

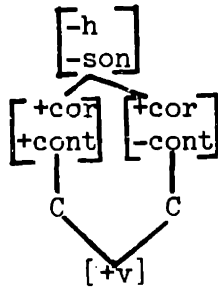

· /bap^h-y-ō/
n/a

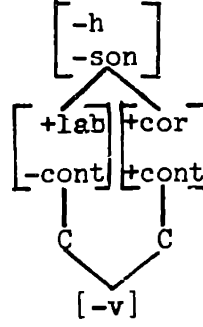

n/a

n/a

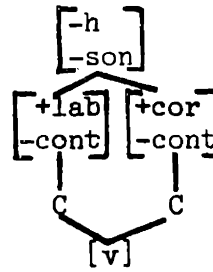

· /eret-y-ō/
n/a

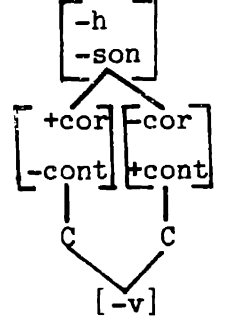

n/a

n/a

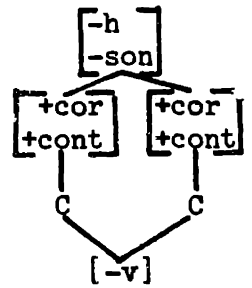

(89)

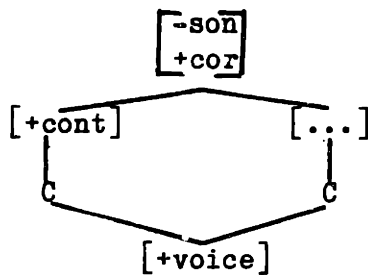

If Σ can also spell out a geminate zz then what stands behind $\kappa\omicron\mu\iota\zeta\omega$, $\alpha\zeta\omicron\mu\alpha\iota$ could be komizzō, azzomai, forms which rule (87.e) can derive along with kerussō, tarassō.

Two arguments support this view: it has been noted that in Mycenaean geminate clusters are not spelled out as such. This is easily explained by the fact that they are heterosyllabic and, therefore, the first member of the cluster, a coda, will fail to be spelled out as a general rule (see Chapter 4, section 4.1). Consider now forms transliterated as me-zo, to-pe-za, wo-ze, which are interpreted (cf. Lejeune 1972 : 113) as corresponding to alphabetic Greek mezdon 'bigger', torpezda (Attic trapezda) 'table', worzde 'works'. The underlying forms of these words are /meg-yōn/, /torped-ya/, /worg-y-e/. Assuming that all the rules in (87), in particular (87.a), (87.b), (87.d) apply in Mycenaean, it is still unexplained why the signs for zo, za, ze spell out the final syllable of what should be mez.don, tor.pez.da, worz.de or wor.de (judging from alphabetic Greek erdō 'to work'). We know from examples like ze-u-ke-si (= $\Sigma\epsilon\upsilon\kappa\epsilon\sigma\iota$ = zdeugesi, 'yoke-DATpl') za-ku-si-yo (= $\Sigma\alpha\kappa\upsilon\sigma\iota\omicron\varsigma$ = Zdakunsios 'from Zakunthos') that the value of the signs used in wo-ze, to-pe-za should be similar to that of alphabetic Greek $\Sigma\epsilon$, $\Sigma\alpha$. And we know that sibilant-stop clusters are heterosyllabic in Mycenaean, the

sibilant coda being always left out in the spelling. How come then that the spelling of what we think is mēzdōn, torpezda is not *me-do, *to-pe-da? The answer to this could be simply that the continuancy metathesis, rule (87.d), does not exist and that rule (87.e) derives, at least in 2nd millenium Greek, mēzzōn, torpezza, spelled regularly me-zo, to-pe-za in the Linear B and, if inherited into 1st millenium Greek, spelled there with a sign of slightly ambiguous value, ΜΕΙΖΩΝ, ΤΡΑΪΤΕΖΑ.

One may think that the present erdō 'to work' on underlying /(w)erg-y-ō/ (cf. ergon 'work' and perfect eorga) represents a problem for this theory. Erdō is generally derived through an intermediate stage erzdō by the regular loss of the interconsonantal sibilant. On our account a stage like erzdō does not exist: rule (a) derives erdyō, rule (b) derives erdzō and rule (e) produces erzzō. The simplification of the geminate sibilant postconsonantly should lead to erzō. Such a form is in fact attested in Mycenaean wo-ze, a present formation which differs from erdō only in ablaut grade. wo-ze is explained by the hypothesis that (87.d) does not in fact exist, exactly as me-zo and to-pe-za are. Only erdō needs comment. I suggest that the problem posed by this form concerns not the phonologist but the historian of the Greek writing system: as there was no sign in Greek for simple non-geminate z, the sign for the other voiced coronal obstruent in the inventory was used to represent phonetic [z].

Erdō is not the only case where one can argue that spells a non-geminate z. The poetic prefix ζα interpreted as zda- of zda-t^heos 'sacred', zda-menēs 'raging', zda-trep^hēs 'well-fed', zda-

p^hlegēs 'full of fire' is generally analyzed (for example in Chantraine 1942, Smyth 1956) as a lautgesetzlich outcome of an allegro pronunciation of dia 'through', dya. According to our proposal to do away with rule (87.d), dya should become dza by (87.b), zza by (87.e) and should be spelled with ζα if the geminate is maintained, with δα if the geminate is simplified. We know that geminate sibilants are maintained word initially (at least in postvocalic position) in Homer, where seuḡ 'rush' lengthens a preceding light syllable and therefore stands for [sseuo]. Thus the ζα -spellings of the poetic tradition, most of which are attested only in the epic language and none of which shows up in the prose or in the Attic comedy, are consistent with our view. But what confirms it is the existence of the δα-variants: da-p^hoinos 'blood reeking' (cf. p^hoinos 'blood-red'), da-skios 'thick-shaded' (cf. skia 'shade'), da-spetalon glossed by Hesychius as polu-p^hullon 'rich in foliage' (on petalon 'leaf' with an unexplained prothetic s). Chantraine (1942 : 169) notes that dap^hoinos, which is Homeric, can be incorporated into a hexameter whereas zdap^hoinos could not since it would make any preceding syllable heavy, yielding unmetrical sequences — ∪ —. Could this mean that the variant spelling δα φοινός of ζα φοινός reflected the option of dropping the initial z in an initial zd cluster, an option used for metrical purposes by Homer? This seems to me much less likely than the hypothesis that ζα spelled zza and δα spelled the degeminated variant za. Preconsonantal sibilants do not drop sporadically in Greek and unmetrical words comparable to would-be zdap^hoinos, like Skamandros, skeparnon 'adze', are not relieved of their initial s in Homer in order to fit

the meter: instead, the initial cluster is counted, exceptionally, as tautosyllabic (Chantraine 1942:110). Thus no precedent is to be found for the treatment da of initial zda. In contrast, the hypothesis that δάφουνος spells zap^hoinos and ζάνθεος corresponds to zzat^heos uses the independently necessary mechanism of degemination to generate the variants, which must have arisen in sandhi: zzat^h eos, zzap^hoinos after a vowel, zat^h eos, zap^hoinos after a consonant and phrase initially.

The \int spellings of single z in erzō (έρζω), zap^hoinos represent an argument against interpreting σ in πρέσβυς, πέλασγος as a faute-de-mieux representative of phonetic [z]. $\sigma\gamma, \sigma\beta$ stand for [sg], [sb]: had the pronunciation been [zg], [zb] the words would have been spelled *πελασγος, *πρεσβυς.

We have so far accounted for the outcome of underlying stop-y clusters in dialects other than Attic, where erettō, tarattō, koruttō, kērutttō correspond to eressō, tarassō, korussō, kērussō of the other dialects. I postulate for Attic rule (90):

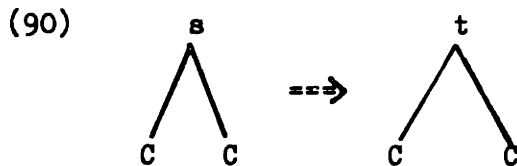

Several details concerning the relative order of the rules discussed so far need to be clarified now. First, the geminate ss of Ionian orressō etc., do not degeminate like those of intermediate possi, genessi (surface posi, genesi). Rule (87.e) must therefore follow degemination. Second, the postconsonantal geminates created by (87.e)

are simplified: thus, intermediate erzzō, panssa 'all-FEM', didonssa 'giving-FEM' from /erg-y-o/, /pant-ya/, /di-dont-ya/ become surface erzō, pāsa, didōsa (the long vowels in the latter two result from CL which accompanies the later loss of n before s). The discussion in section (5.3.2) makes it clear that this instance of Degemination is in fact the effect of Stray Erasure: the rz, ns clusters cannot be codas and the zz, ss clusters cannot be onsets, in both cases because they do not meet the Minimum Sonority Distance requirement on tautosyllabic clusters. What needs to be explained is why rule (90) has not applied in

pans a
 |||N|
 CVCCCV

before Stray Erasure, yielding

pant a
 |||N|
 CVCCCV

eventually *pantta To explain the coexistence in Attic or erettō and intermediate pansa from panssa we must order (90) after Stray Erasure, so that it will not be applicable to the latter form. This is possible and may be kept consistent with our general assumption that Stray Erasure is a convention applying to the output of an entire level in a phonological derivation if we assume that all word internal stray nodes are erased at the end of the lexical component and that rule (90) is a post-lexical rule. The post-lexical aspects of the derivations of erettō and pāsa are shown in (91):

(91) a.

eretto

/eret-y-o/

end of
lexical
component



b.

pasa

/pant-y-a/

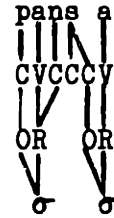

Stray

Erasure

n/a



postlexical
component

(90)



n/a

(n → ∅ / __s)

n/a



(CL)

n/a



5.6 Excursus: the heterosyllabicity condition

Some of the assimilation rules discussed here require that the cluster undergoing them be heterosyllabic: more precisely, that the two consonants not belong to the same onset. This section presents more evidence for (a) heterosyllabicity as a possible condition on assimilation rules and (b) heterosyllabicity as a condition on the particular assimilation rules of Greek discussed.

I begin by citing a case where the heterosyllabicity condition has been invoked before. Hooper (1972) cites the following facts of Spanish: a nasal assimilates in place of articulation to a following

segment if (a) it is separated from it by a word boundary or (b) the segment is not a glide.

(92) a. Assimilation

un beso 'a kiss' [unβeso]

un gato 'a cat' [ungato]

un hielo 'an ice' [uñyelo]

un huevo 'an egg' [unweβo]

b. No assimilation

nieto 'grandson' [nyeto]

nuevo 'new' [nweβo]

Similarly, l becomes palatal before y across word boundaries (al hielo 'to the ice' [aλyelo]) but not inside words (aliento 'breath' [alyento]). Hooper notes that in both cases place assimilation occurs only when the cluster is heterosyllabic: across word boundaries the final C of al or un remains a coda in the word final syllable, thus un.ye.lo, al.ye.lo, and for this reason the sonorant-y cluster qualifies for place assimilation. Inside words the sequence sonorant-y is tautosyllabic and place assimilation is blocked. When the sequence nasal-C involves as its second member any other segment than a glide the syllabification rules of Spanish dictate that it will be heterosyllabic regardless of intervening word boundaries: and accordingly, any nasal-C sequence of this type will undergo place assimilation.

Hooper mentions another case where the heterosyllabicity condition is necessary. Obstruents in Spanish voice partially before a

voiced consonantal segment under the following circumstances: s
voices before any voiced consonant, stops voice only before nasals:

(93) a. Voicing

desde 'since' [des^z de]

asno 'donkey' [as^zno]

Israel [is^zrael]

atmosfera 'atmosphere' [at^dmosfera]

technico 'technical' [tek^ɸniko]

b. No voicing

aplicar 'to apply' [aplikar]

acreditar 'to credit' [akreditar]

The Voicing rule, as Hooper notes, can be pared down to a simple rule: Voice a consonant before a heterosyllabic segment. To accomplish this simplification, we must note that the clusters which fail to undergo the rule in (93.b) are the tautosyllabic stop-liquid clusters of Spanish, in contrast to the heterosyllabic clusters stop-nasal, continuant-C of (93.a) <21> .

The Voicing rule of Spanish is almost identical to that posited for Greek in (82): most surface differences result from the differences in syllabification between the two languages. While in Spanish only stop-liquid clusters can form onsets, in Greek voiceless stop-nasal sequences are also in the class of tautosyllabic sequences. As a result, kn, k^hn, km, k^hm, pn, p^hn, tm, t^hm all surface unvoiced in Greek, a fact which follows not from formal differences between the Greek and the Spanish Voicing rules but from the different onset structures of the two languages.

Latin shares with Greek a significant portion of its set of segmental assimilation rules: but voicing and nasality assimilation, the two processes I will discuss, apply in Latin to a larger class of clusters than in Greek. The reason is that the two processes apply in both languages to heterosyllabic clusters only and the heterosyllabic clusters of Latin are more numerous than those of Greek.

As in Greek, labial stops assimilate in Latin to a following nasal: the root /sop/ 'to sleep' (as in sōp-i-ō 'to put to sleep', sop-or 'sleep') undergoes the equivalent of Greek Labial Assimilation before the suffix -no- in scmnus /sop-no-s/ 'slumber'; the place name of the region inhabited by Sabīnī is Samnium /Sab-nio-m/. In general there are no labial stop-nasal sequences that surface in Latin, an effect attributable to the existence of Labial Assimilation. Note now that pn clusters, like that of /sop-no-s/, undergo the Latin Labial Assimilation: in Greek we saw that no voiceless labials participate in the rule when followed by n. If Labial Assimilation is governed by a heterosyllabicity condition, as we argued on Greek internal grounds, its different effect on Latin clusters can be explained by the difference in syllabification: Latin does not syllabify any stop-nasal sequence as part of the same onset.

As in Greek, velar stops are voiced in Latin before a nasal: there are no kn, km sequences in the language because they all become gn, gm. Alternations resulting from this process are, for example, sec-ō 'to cut' vs. seg-mentum 'a piece cut off'; dec-et 'is appropriate'; dig-nus 'suitable'; salic-is 'willow-GENsg': salig-nus 'made of willow wood'. Morpheme internally the rule can be shown to have

applied in nīdōr 'smell arising from something burning' which is etymologically related to Greek knisa 'the steam and odour which exhales from roasting meat' : the initial k was voiced to g and then was lost, as g is always before n in word initial position (cf. nātus from gnātus, nāscor from gnāscor). Note again that voicing applies in Latin to clusters which are inaccessible to it in Greek : kn, km assimilate to gn, gm because they are, in Latin, heterosyllabic clusters in all positions in the string<22>. In Greek they are heterosyllabic only when separated by a level 2 suffixal boundary.

The heterosyllabicity condition is also useful in simplifying the system of Latin gemination rules: at prefix boundaries we can observe the application of a very extensive process of gemination, illustrated in (94), some of whose subcases must also be allowed in morpheme internal position:

(94) a. Across prefix boundary	b. Morpheme internal<23>
ob : of-ferō 'to offer'	- no <u>bf</u> , <u>pf</u>
oc-currō 'to run to meet'	- no <u>bc</u> , <u>pc</u>
sub : sur-ripiō 'to steal'	- n/a (<u>tenebrae</u> , etc.)
sum-moveō 'to remove'	- no <u>bm</u> , <u>pm</u>
ec : ef-fugiō 'to flee'	- no <u>cf</u>
ad : ag-grediōr 'to step to'	- no <u>dg</u> , <u>tc</u> (cf. <u>siccus</u> 'dry' from underlying /sit-ko-s/)
al-loquōr 'to address'	- no <u>dl</u> (cf. <u>sella</u> 'chair' from underlying /sed-la/)
ar-rideō 'to laugh at'	- n/a (cf. <u>ladrō</u> 'robber')
an-nuō 'to approve'	- no <u>dn</u> , <u>tn</u>
af-fluō 'to flow to'	- no <u>df</u> , <u>tf</u>

I have indicated on the right-hand column the cases in which gemination should be permitted to apply in morpheme internal position so as to explain the systematic absence from Latin of certain clusters, like [-son][-son,-cor] or [-son,+cor]¹. The notation no bf, no pf etc. means that the absence of such clusters from morpheme internal position requires the gemination rule to be applicable to them not only across a prefix boundary but generally. The notation n/a indicates that the gemination attested across the prefix boundary must be blocked morpheme internally for the relevant cluster. In some cases, like the alternation sitis 'thirst' : siccus 'dry', the morpheme internal application of gemination is directly observable. Note now that the morpheme internal column differs in only two cases from the across- prefix column: the clusters br, dr fail to undergo the rule

morpheme internally but undergo it across the prefix boundary in minimal contrast to dl clusters, which undergo gemination in all positions. This seems to be the trademark of a heterosyllabicity condition on the gemination rule: clusters that are heterosyllabic, whether because they are separated by a prefix boundary like /sub-rapiō/ or /ad-rideō/ or because they do not conform to the onset structure of Latin (like /sedla/, /sitko-s/) undergo gemination, onset clusters do not: this is why the morpheme internal occurrences of br, dr seem immune to gemination.

5.7 Back to the segmental linking condition

We embarked upon the discussion of Attic assimilation rules in the preceding sections in order to verify the hypothesis that segmental linking is a necessary condition for a stop to be incorporated in the Attic rime. Recall that the segmental linking hypothesis had succeeded in explaining the peculiar Attic pattern of word final stop deletion as well as the fact that no CL effects accompany that type of deletion. The natural extension of the hypothesis was to cover the other cases of CL-less deletions: in particular the deletion of a coronal stop before the suffix k of the perfect stem in /CV-komid-k-a/ ==> kekomyka, /CV-anut-k-a/ ==> ānūka<24>. But in order to attribute these deletions to the fact that the stop was not segmentally linked and could not be syllabified as a coda, we had to find out if any assimilations could have applied to the simplified clusters.

Our conclusion in this respect can be summarized as follows: the rule of aspiration and voicing assimilation (LFA) which applies to certain sequences of obstruents is not met by the [+coronal][-coronal]

clusters tk, t k, dk which simplify, as it is not met by any clusters of obstruents whose second member is not a coronal. We reached this conclusion by considering the case of sb, sg clusters in pelasgos, presbus, whose second members are also [-coronal] obstruents: we noted that if voicing and aspiration assimilation had applied to such clusters the sequences spelled $\sigma\gamma$, $\sigma\beta$ would have contained a phonetic [z]. There is, however, evidence, discussed in section (5.5.5), that single -- as opposed to geminate -- [z] is spelled ζ in pre-hellenistic Greek. That evidence is incompatible with the idea that there was any voicing assimilation in the underlying clusters sb, sg. We must therefore maintain the restriction on LFA stipulating that the second member of the cluster undergoing the rule is [+coronal]. What this means for kekomika and similar cases is now clear: the stop preceding the non-coronal stop in such forms could not undergo any rule establishing a segmental link to a following C slot. For this reason it could not meet the Coda rule (38) and had to be left stray, later to be erased by Stray Erasure along with other unsyllabified material. The deletion and the lack of CL can thus be explained.

What can also be explained is why there are no clusters in Attic whose first member is a stop and whose second member is a non-coronal obstruent: we have ruled out by our statement of the LFA and the coda rule (38) not only tk, dk, t k clusters but also pk, kp, p k, k p, all of which systematically fail to occur. In all of these cases the first stop has not undergone LFA and is therefore not syllabifiable as a coda.

We also investigated assimilation rules that feed the Coda rule (38) in different ways: either by turning an underlying stop into the continuant s (as rule (78) does in changing /od-m̄/ into osm̄) or by turning a stop - y sequence into a linked cluster, pt, geminate z or geminate t as Y-Assimilation does in apt̄ from /ap -y-ṽ/, komizz̄ from /komid-y-ṽ/, erett̄ from/eret-y-o/. Finally, we discovered that the simplest formulation of the voicing rule necessary in order to derive forms like prāg-ma from underlying /prak-mat/ was (82):

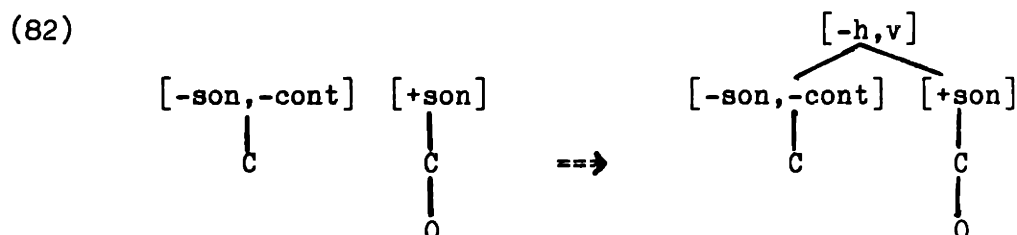

Rule (82) will apply to create a segmental link not only to the km, k.m cases that motivated it in the first place but also to any stop-sonorant sequence which is not part of the same onset: for example to dn in smerdnos (syllabified smerd.nos), to gn in agnos (syllabified ag.nos), to bl in bublos (when syllabified bub.los, but not when the tautosyllabic option is taken bu.blos). In all these cases the application of (82) will have no segmental effect: but the structure of the cluster will be changed and the stop will share a subpart of its matrix with the following onset C:

attested in the grammars of three other languages: Diola Fogny, Japanese, and Luganda.

In Diola Fogny, word internal onsets and codas are limited to one consonant. But while any one consonant may appear in onset position a coda must dominate a liquid, the first member of a homorganic nasal-obstruent cluster or of a geminate nasal cluster:

- (96) a. -saltɔ 'be dirty'; -ɔrtɔ 'negative suffix'
b. takumbi 'must not'; nigangam 'I judge'; papjimanj 'you(pl)
will know'
c. nammimɪn 'he cut (with a knife)'; ningnngɛn 'I placed,
nipappa 'I rub arms'; nipappan 'I cried' (data from Sapir 1965)

At word margins one extra consonant is allowed. For the word final position this means that any one single consonant following the final vowel will be permitted; this also means that the extra final consonant can be the second member of a homorganic nasal-stop cluster.

- (97) a. ijaut 'I did not come'; kupilak 'the children'; ɔnɪnɔw 'the man;
nikɔkɔb 'I waited'
b. papjimanj 'you (pl) will know'; aŋkaŋk 'hard'; kagūmp 'ashes'.

The noteworthy aspect of this syllabification system is the limitation to which word internal codas are subject. One must stipulate that codas in Diola Fogny cannot be of lower sonority than the nasals. But in addition one must account for the fact that the nasals, the lowest in sonority among permissible codas, must be segmentally linked, either as geminates or as homorganic with a following

- (99) a. /lɛt-ku-jaw/ => lɛkujaw 'they won't go'
b. /jaw-buŋar/ => jabuŋar 'voyager'
c. /kɔ b-kɔ b-ɛn/ => kɔkɔbɛn 'long for'
d. /tɛy-tɛy-ɛn/ => tɛtɛyɛn 'cause to run'
e. /ujuk-ja/ => ujuja 'if you see'
f. /na-lan - lan/ => nalalan 'he returned'
g. /na-yɔkɛn-yɔkɛn/ => nayɔkɛyɔkɛn 'he tries'
h. /lan-m/ => lam 'return'

There is some reason to believe that the deletions in (99) result from the failure of syllabification to assign structure to the consonants which do not meet the phonotactic specifications of a coda. On this view, all we need to state is: (a) that the rime structure of Diola is $V(V)(C)$, where the C is either a liquid or a nasal that is segmentally linked to a following position in the word template; (b) that there exist nasal geminates and a rule which assimilates a nasal in place of articulation to a following obstruent; (c) that the Diola word template is specified to contain an initial and a final optional extrametrical C position. Clearly statements like (a), (b) and (c) are independently necessary in order to characterize the Diola syllable structure, its consonant assimilation rules and the asymmetry between word medial and word peripheral clusters. If we choose to express (a) by formulating the Diola Fogy coda rule as in (100) below, then we will make unnecessary any further rules of consonant deletion:

(100) Diola Fogy Coda rule.

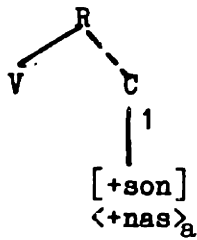

<C₁ is segmentally linked to a following C₂ and C₂ is in the word template>_b

a only if b

The essential features of the Diola Fogy system are encountered elsewhere, with only slight variations. In Japanese and Luganda geminate clusters and homorganic nasal stop sequences are the only providers of word internal codas (Fujimura and Lovins 1978; Clements 1978). Thus apparently all consonants must satisfy the condition of segmental linking in order to be a Japanese or a Luganda coda. Luganda, moreover, lacks the option of a final extrametrical position and, as a result, no consonant can appear word finally because there is no independent position in the word template to which a word final coda can be segmentally linked.

Seen in this context, the segmental linking condition on the Greek coda rule is less surprising. As in Diola Fogy, it is the lower sonority coda segments that must meet the condition in Greek. And, as in Diola Fogy, the segments that must meet the condition and do not are lost without CL.

6. The order of syllabification operations

The interest of the segmental linking condition for this study of

syllabification processes becomes apparent when we relate two of the central ideas in this chapter:

- (101) a. A stop may become a coda only if it is segmentally linked to a following position in the word template.
- b. Some of the rules which create segmental linking may apply to a cluster only if it is heterosyllabic.

(101.b) refers to the fact that rules (72), (78), and (82) must be prevented from applying to onset clusters. The conjunction of (101.a) and (101.b) means that onset clusters are determined before rules (72), (78) and (82) apply and that stops can assume a coda position only after (72), (78), (82) have applied:

- (102) Onset Rule : creates some tautosyllabic clusters.
- Rules (72),(78),(82): fail to apply to these clusters; create segmental linking.
- Coda Rule : is conditioned by the existence of a segmental link between a stop and a following C.

(102) contains the basic ingredients of an argument that the syllabification of a string proceeds in several distinct steps, each of which may be followed by other phonological rules, in this instance by the assimilation rules discussed. But the ordering relation (Onset Rule - Assimilations - Coda Rule) it establishes is compatible with two views of syllabification: on one interpretation Onset Rule and Coda Rule are distinct rules of syllabic adjunction, which is what allows one to apply before assimilations and the other one after assimilations. The other view is that syllabification is the scanning of the phonological string by a syllabic template which organizes stray segments into

permissible syllables. On this view all stray segments which can be incorporated during any given scan into a well-formed syllable are incorporated. Syllabification, on this hypothesis, is allowed to apply after any phonological operation, bringing its output in line with the requirement that all segments must be attached to the nodes of a well-formed syllable. Our conclusion that some assimilation rules apply between the point in the derivation when complex onsets are created and the point when stops can become codas is entirely compatible with this model of syllabification: assuming that a first syllabification scan initiates each phonological cycle and that rules (72), (78), (82) follow it as the first regular phonological rules we obtain derivations as in (103):

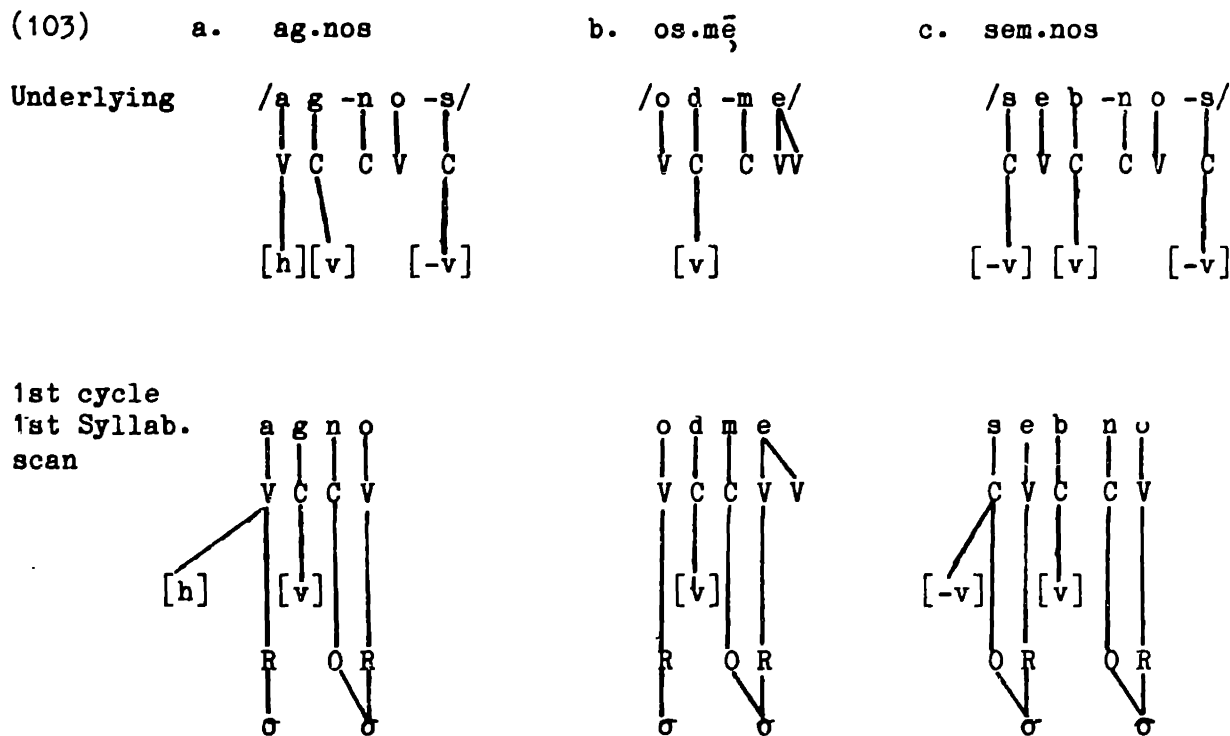

(78)

n/a

n/a

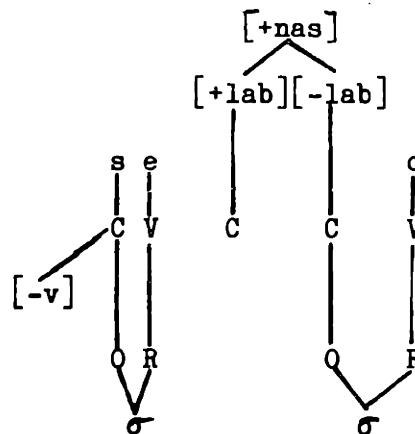

2nd Syllab.
scan

n/a

n/a

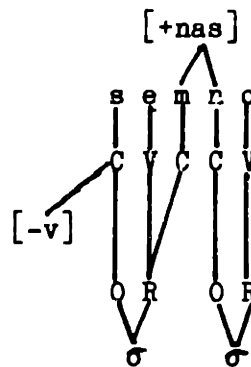

(72)

n/a

n/a

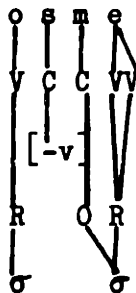

3rd Syllab.
scan

n/a

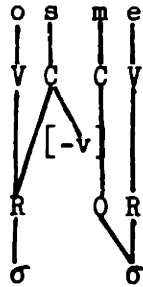

n/a

(82)

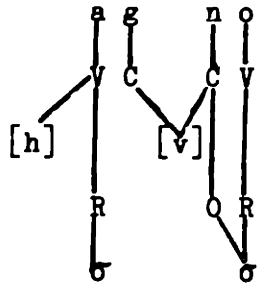

n/a

n/a

4th Syllab.
scan

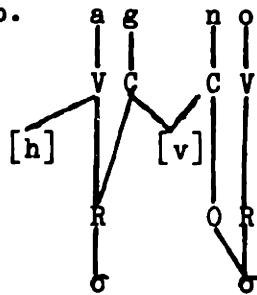

n/a

n/a

The operation of each of (78), (72) and (82) makes new segments available for attachment as codas. As the rules apply, syllabification checks their output incorporating the newly eligible codas.

I cannot directly evaluate the consequences of the view of syllabification inherent in a derivation like (103): as mentioned in chapter 1, section 3.2.4. there is some evidence that the structures created in the output of syllable changing rules like syncope is not identical to the output of the first syllabification scan. Such evidence, if clearer and more abundant, would invalidate the multiple scan approach illustrated in (103).

But there is also good evidence to the effect that the same or similar syllabification rules can be subject to different ordering conventions in different languages : we consider in the remainder of this section the ordering statements that must govern the Attic Onset rule and compare it with the Onset rule of Mycenaean. We will conclude that Attic, unlike Mycenaean, had an Onset rule limited to level 1. This type of evidence tends to support the idea that core syllabification rules have distinct ordering privileges, like all other phonological rules, and do not apply as part of a single syllabification block.

We observed in discussing rule (78) that inside a level 1 constituent (stem without inflectional endings) clusters of voiceless coronal stops followed by m count as tautosyllabic, in accordance with the results of the Onset rule (34.a). Across a level 2 boundary , however, the same clusters are heterosyllabic, as evidenced by the applicability of (78) to t^h-m, t-m clusters created at level 2. The same observation was made in connection with the rule of Sonorant

Voicing stated in (82). Inside a level 1 constituent, $\underline{k^h m}$, \underline{km} clusters fail to meet the heterosyllabicity condition of (82) : they do however satisfy it when separated by a level 2 boundary. When I first introduced the rules (78) and (82) I assumed, for ease of exposition, that the root final stops in intermediate forms like $\underline{pe-p\bar{e}t^h-mai}$, $\underline{te-teuk^h-mai}$ are syllabified as below :

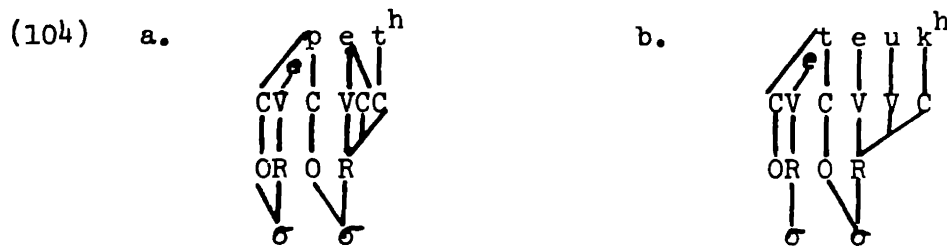

(104) gives the representations of the inputs to the level 2 affixation of -mai. If so, the fact that the root final stops are not affected by the level 2 application of the Onset rule would follow from the fact that they are no longer stray at level 2. That simple explanation is however incompatible with our conclusion that all stops must be segmentally linked in order to be syllabified as codas. Thus, since (38) rather than (34.b) is the Coda rule of Greek, the root final stops of (104) cannot undergo the Coda rule until they either meet the segmental linking condition or they change to s or sonorants. These changes are brought about by the operations of rules like (78), (82), both of which have been shown to be ordered in the cycle after the Onset rule. Therefore, if the Onset rule is applicable at level 2, the sequence of operations Onset rule < (78) or (82) should produce $\underline{pe.p\bar{e}.t^h-mai}$, $\underline{te.teuk^h-mai}$ to which neither (78) nor (82) are applicable. This we know to be incorrect, as surface

- pepēsmai, teteugmai show the effects of (78) and (82). Thus, the only explanation for the fact that the heterosyllabicity condition on (72), (82) is met at level 2 by underlying t^h_{-m} , k^h_{-m} clusters is that the onset rule is no longer applicable at level 2. Note that this conclusion does not rely on the assumption that the Coda and Onset rule are distinct operations : it can be more generally stated as Complex Onsets are not created beyond level 1.

The difference between the syllable structures created at level 1 and level 2 concerns exclusively complex onsets : the coda clusters created by the adjunction of level 2 affixes are identical to the coda clusters created at level 1 , as shown by pairs like t^helk.tro-n 'charm' from /t^helg-tro-n/ and p^ht^henk.tos from /p^ht^heng-to-s/, the latter containing a level 2 (inflectional) affix -to-. The partial similarity between level 1 and level 2 syllabic structures is naturally captured by the ordered rule approach advocated here: as any phonological rule, a core syllable rule may exit at a level prior to the end of the cyclic derivation, while all other syllabification rules remain in the cycle. A related point is that the ordering restriction on the Onset rule of Attic as analyzed here must be language-specific. This aspect of the analysis is supported by the observation that the stop-sonorant clusters created at level 2 are tautosyllabic in Mycenaean (cf. footnote 19 and chapter 4, section 4.2.)

Chapter 3 - Footnotes

1. This was not in 1923, as it is not now, the unanimous view on the matter: a review of the literature on this debate about the nature of the syllabic weight distinctions is found in Zirin 1970. A study as recent as Pulgram 1974 reinvents the poetic convention theory of syllabic weight in apparent ignorance of past history.

2. For a critique of Wheeler's hypothesis see Postgate 1925, who demolishes most of the evidence for retraction as an internal Greek phenomenon.

3. On the lack of aspiration in the reduplicating syllable see below. The root ak' began in earlier times with w so that iak^ho could stand in Homer for wiwak^ho. In Attic however, there is no evidence for underlying initial w and the root was restructured as vowel initial.

4. On isolated and archaic formations like memnēmai, kektēka see Chapter 4, section (4.3.). Unlike the variants attested for bl- and gl- initial roots, the exceptional reduplicated perfects of the kektēka type are attested for only central vocabulary items and form a clear minority within each class of heterosyllabic root initials.

5. Cluster simplifications which do lead to CL must have affected consonants to which a syllabic position had already been assigned. See Chapter 2, in particular footnote 19.

6. Lupas, (1972 : 136) cites dmoīs 'female slave' and oidma

'swelling sea', as attesting the cluster dm in Attic. But neither appears in the Attic prose or comedy, our best sources for pure colloquial Attic. They are both epic borrowings into the language of the tragedy. On the fate of dm sequences in this dialect see below section (5.5.3).

7. Underlying and intermediate Vns become Vs: ^hens will therefore surface as ^hes. The CL effect on the preceding vowel indicates that n was lost in ^hens, as elsewhere, after it had been syllabified as a coda. This is why it is included in (26).

8. Some of the gaps are clearly accidental: l is followed by only one type of branching onsets: km; the only branching onsets following a coda s are kl, ^hkn, ^htl, ^htm; the only branching onsets following a stop are tr, ^htr; a cluster consisting of a liquid and a voiced consonant is followed by a nasal onset only (lg.m, rg.m, rd.n); the only branching coda followed by a branching onset is lk in ^halk.tron; the complex onsets km, ^hkm, ^htm, tn, ^hpn, do not occur word initially. My decision to call such gaps accidental is based on two considerations. First they don't seem to form any kind of pattern. Second, these gaps have no known underlying sources: there are no underlying l.tm or s.km or rp^h.t^hl sequences and no underlying initials in km, ^hkm, tn etc. Since we are interested in the rules which map underlying representations onto syllabified structures we will not be concerned with explaining the absence of surface clusters that lack a known source.

9. On the rules mapping the underlying form onto the input representations to cluster simplification see section (5.5).

10. The sound [ɲ] is spelled out by η in Greek, which leads authors like Lejeune (1972 : 146) to misleading statements on the phonetic reality behind η : "devant consonne, il y a eu simplification graphique de $\eta\mu$ en η ". Lejeune himself notes that the Greek name of the sound [ɲ] cannot be interpreted unless one assumes that the digraph $\eta\mu$ was also spelling out [ɲ m]: this name was an-ma, spelled $\alpha\eta\mu\alpha$.

11. We would expect this to be invariably the case, given our comments on exhaustive surface syllabification (Chapter 1, section (3.3)). See however Clements' and Keyser's arguments (1981) for word medial consonants in Klamath which are either stray or adjoined to the syllable by rules other than onset or coda formation.

12. One may think that the problem can be avoided by stating the coronal stop deletion rule as a C-slot deletion. The present framework of autosegmental phonology cannot rule out such an operation. I would suggest, however, as a first step in the direction of restricting the power of the autosegmental notation, that rules whose structural description make exclusive reference to the segmental tier -- and the coronal stop deletion will have to be such a rule -- have their structural change stated at the segmental level. Conditions of this nature are indispensable in this stage of the development of a multi-tiered theory of phonological representations, when a simple consonant loss phenomenon can be formulated in no less than five different ways (deletion of the segment, deletion of the C slot associated with it, deletion of the association line between the segment and the C slot, deletion of the syllabic node to which the C slot is

attached, deletion of the association line between the syllabic position and the C slot). If the proposed restriction on segmental tier rules is adopted then no alternative statement of the coronal stop deletion will avoid the problem posed by the lack of CL.

13. A dialect of Greek that lacks the degemination rule should, if everything else was equal, have k^h ariss, orniss etc. Such clusters should behave prosodically like the final ss clusters of Latin in the Plautinian prosody: the final C should resyllabify before a following word initial vowel (like miless est = mi.les.ses: 'the soldier is') leaving behind a closed syllable. I lack the relevant information on the prosodic behavior of word final -ss in Homer.

14. The extent to which the Attic version of Grassmann's law is shared by other dialects is unclear. Lejeune (1972) provides interesting, if fragmentary, evidence that other dialects deaspirated the second rather than the first stop.

15. In laskō, underlying /lak-sk-ō̄/, the metathesis between the root final stop and the suffixal z takes place before LFA: after metathesis, the structural description of LFA is no longer met and, for this reason, BL cannot propagate aspiration onto the final member of the cluster.

16. The present form misgō of the root mig 'to mix' (more frequent present form mēgnumi) could be interpreted as a -skō present as well, thus /mig-sk-ō̄/. If this etymology is correct, then BL should be extended to cover all laryngeal features:

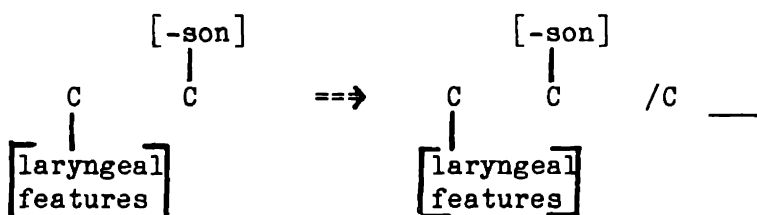

The derivation of misgō will then be /mig-sk-ō/ => misgkō by

Metathesis =>

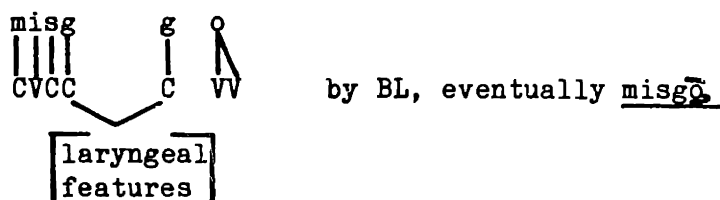

17. Two verbal roots t^hu-ō 'to sacrifice' and ti-t^he-mi 'to place' undergo GL as triggered by an aspirated suffix: e-tu-t^he 'was sacrificed', tu-t^he-s-omai 'I will be sacrificed', e-te-t^he 'was placed', te-t^he-s-omai 'I will be placed'. Sommerstein (1973) bases his analysis of GL on these forms. I have chosen to disregard them both because ōrt^hō-t^he represents a minimally different form where GL fails to apply and because an analysis like Sommerstein's, which is centered on them, is inevitably forced into a mass of strange stipulations.

18. Attested in vase inscriptions (Lejeune 1972: 77). The epic Admetos and forms like dmet^hes 'tamed' from the paradigm of damazdō continue to be used in the language of the tragedy, along with other epic borrowings. The vase inscriptions attest also Kasmōn for Kadmōn and Agamesmōn for what Lejeune (1972:77) believes to have been

*Agamedmōn.

19. Lejeune (1972 : 76) notes that Mycenaean, like the epic dialect, preserves tm, t^hm even when the latter belongs to an inflectional suffix: thus t^hm is indicated not only in stat^hmos 'farmstead' spelled ta-to-mo, where the to-mo spelling of the cluster indicates that it is tautosyllabic) but also in pepit^hmenoio 'persuaded-GEN', ararmotmenos 'fitted' spelled pe-pi-te-me-no-jo, a-ra-ro-mo-te-me-no. In the last two cases the coronal stop is preserved before the participial suffix -meno-. One cannot tell however whether Mycenaean lacked rule (62) or not: as the te-me spellings indicate, the tm, t^hm clusters were tautosyllabic even across an inflectional boundary. It is then possible that the difference in syllabification alone is responsible for the difference between Mycenaean pepit^hmenoio and Attic pepēsmenos.

20. I omit the derivation of the reduplicating syllable, irrelevant here.

21. Hooper (1972) implies that nasal - glide sequences are also onsets in word medial position. This is, however, not necessary for her argument, since nuevo could be syllabified

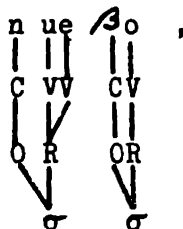

with u in nuclear position, and the heterosyllabicity condition will still block voicing. Harris (1982) has shown in fact that the correct syllabic structure of Spanish postconsonantal glides is as shown

above, with the glide as a first element of the nucleus.

22. One may wonder how it is possible to tell that Latin does not allow stop-nasal onsets: the only stop-nasal clusters that surface in Latin are the gn, gm sequences. Is it possible to claim, then, that were it not for the application of some assimilation rules, the Latin and Greek onset structures would be identical? I think not, for the following reason: Latin borrowed a few lexical items from Greek which contained the voiceless stop -nasal sequences. Such borrowings are attested already in the pre-classical poetry of Plautus and Terentius, where drachma (also spelled dracma) 'coin', techna 'scheme, ruse' are consistently syllabified drac.ma, tec.na (for example in *Andria* 2,6,20; *Heautontimoroumenos* 4,3,40; *Mostellaria* 2,1,23; *Bacchis* 3,2,8): this is significant because Plautus and Terentius always syllabify a stop-liquid cluster (other than tl: see below) as an onset. Thus the attested instances of heterosyllabic cm, cn in the comic poetry cannot be written off as merely testifying to the possibility of heterosyllabic assignment: we must admit them as proof that stop-nasal clusters were obligatorily heterosyllabic. Latin grammars like Kühner-Holzweissig (1966) take the few classical instances of tautosyllabic cn, cm as indicating a general possibility for onset assignment of all stop-sonorant clusters: but a check in Quicherat-Chatelain's Thesaurus Poeticus Linguae Latinae (1899) shows that the vast majority of Greek loans containing voiceless stop-nasal sequences were always heterosyllabic in Latin. It also shows that tl clusters, absent from native Latin words, were heterosyllabic when introduced by loans: atletice 'athletically' is scanned at.le.ti.ce in Plautus' *Bacchis* 2,3,14. This last observation further confirms our hypothesis

about the membership of the Latin onset class: what rules out tl as a possible onset is the Minimal Sonority Difference requirement of 6 intervals in conjunction with the sonority scale (76) given for Latin in Chapter 1. That scale and any scale that predicts heterosyllabicity for tl clusters will also rule out stop-nasal onsets, regardless of whether the stop is voiced or voiceless.

23. For lack of a better term I use morpheme-internal here to mean part of the same prefix or compound member: thus in /sit-ko-s/, /sed-la/ the underlined clusters count as morpheme internal because they belong to a single compounding unit.

24. There are no perfects on stems other than the sonorant and coronal obstruent stems: velar and labial final stems form their perfects either by aspirating the stem final stop or by adding the perfect endings directly to the bare stem. This is why no underlying clusters pk, kk arise in the perfect.

Chapter 4 : The Structure of Heterosyllabic Initials

1. Introduction

This chapter seeks to determine the structure of heterosyllabic initials : the consonant clusters that can occur in Greek at the beginning of a word or compound member and which, in postvocalic position, must be heterosyllabic. By definition, all initial consonant clusters which do not correspond to the description of onsets are heterosyllabic initials. Their list was given in (27.b), chapter 3, and is repeated in abbreviated form below :

- (1) a. [-son, +cont] C (C) : sm, sp, sk, st, spr, skn, stl, zd, etc.
- b. [-son, -cont, -cor][-son,+cor] : kt, pt, k^hs, p^hs, etc.
- c. [-son, -cont, + voice][+ son, + ant] : gn, gl, bl, dn.
- d. mn .

I will argue that the initial member of a heterosyllabic initial is a stray consonant, as shown in (2), throughout the lexical component of the phonology :

- (2) Heterosyllabic initial : gn in gnōskō

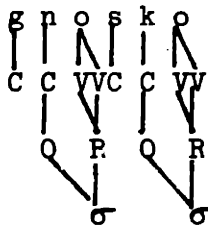

The stray initial member of a heterosyllabic initial will be shown to have three options : (a) that of being syllabified by a language specific

rule as the coda of a preceding syllable; (b) that of being adjoined to the next syllable or onset by a rule applying in Greek to only a subset of the underlying heterosyllabic initials; (c) in the default case, that of being deleted along with other unattached material by the Stray Erasure Convention ((72), chapter 1).

There are four conceivable representations of the difference between regular onsets, as described for Attic by rule (34.a) in chapter 3, and heterosyllabic initials : one possibility is that the heterosyllabic initials are onsets of a different sort from the ones already studied, onsets involving different internal constituents ; another option is that they are not onsets, but different constituents of the syllable - I will call them appendices, using the terminology introduced by Halle and Vergnaud 1981 - on a par with the onset and the rime; finally, they could be degenerate syllables, syllabic units lacking a nucleus <1> . All four alternatives are illustrated in (3) :

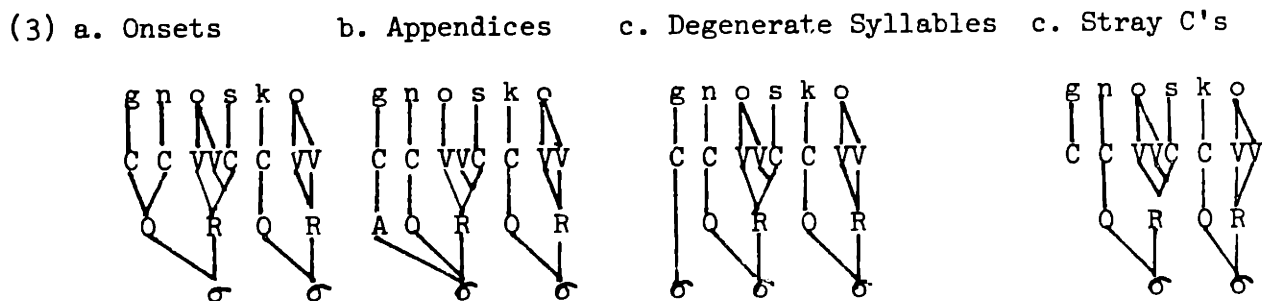

The hypothesis illustrated by (2.a) will obviously have to be supplemented by a theory of onset structure that will differentiate the regular Attic onsets, those subject to correptio Attica and those which reduplicate like gr in gegrap^ha , from heterosyllabic initials. Such a theory has in fact been proposed by Cairns and Feinstein (1982) : details aside, its main claim is that the first member of a heterosyllabic initial

is a constituent of the syllabic node Onset.

The empirical content of the notation in (3.c) will depend on the theory of degenerate syllables that we adopt : I will start by making the optimal assumption that degenerate syllables have no properties differentiating them from regular syllables, aside from the lack of nucleus.

Finally, according to the stray C theory, the g of gnōmē is neither an onset nor an appendix nor a separate syllable : it is an unaffiliated consonant.

There are a number of empirical considerations that favor representations like (3.d) over the alternatives, as intermediate structures of the heterosyllabic initials. But even if such evidence had not been available, the stray C analysis should be preferred because it relies on the existing distinction between a segment's state of being or not being linked to a syllabic position. In contrast, the analyses illustrated in (3.a-b) must derive the properties of heterosyllabic initials from the stipulated characteristics of otherwise unnecessary syllabic constituents. We have seen in chapter 1 that the evidence for relatively uncontroversial nodes like Onset and Rime is the subject of debate. The evidence for onset internal structure and that for the node appendix is, heterosyllabic initials apart, nonexistent <2>. The degenerate syllable analysis, on the other hand, which can claim some independent support, will have to relate the properties of heterosyllabic initials to the absence of a nucleus, thus effectively abandoning the claim that degenerate syllables are full-fledged syllables. It is nonetheless instructive to observe how a richer descriptive apparatus, like the one implied by the representations in (3.a-c)

leads to more cumbersome analyses of the properties of heterosyllabic initials than the relatively elementary mechanism of the stray C hypothesis. For this reason, the options illustrated in (3) will continue to be compared throughout the chapter, as we inventory the properties of these clusters.

I will begin by showing that a number of phenomena whose locus is the syllable initial position fail to apply to the first member of a heterosyllabic initial.

2. Heterosyllabic initials in 1st millenium Greek

2.1. Reduplication

We introduced the facts of Attic reduplication in the last chapter (section 4) to validate the testimony of the Attic prosody and to establish that most clusters indicated as tautosyllabic by correptio Attica are obligatorily assigned to the onset position. Our argument was based on the existence of two patterns of reduplication in consonant initial roots : the class (a) pattern, which consists of the reduplication of the first root consonant, is restricted to verbal roots that begin with a single consonant or with a cluster subject to correptio. Class (b) reduplications, manifested on the surface as the prefixation of e to the root, are restricted to root initial clusters that may not be subject to correptio. We have shown that the distribution is predictable from the autosegmental statement of perfect reduplication and the assumption that most clusters subject to correptio are obligatorily syllabified as onsets :

(4) Perfect Reduplication in Attic (assuming the stray C analysis)

a. Prefixation

Prefix CV to the root.

b. Linking

Associate the CV slots left to right to the melodic core of the first syllable.

c. e-Insertion

Attach an empty V slot to an inserted e.

Thus a correptio cluster like the gr initial of the root grap^h 'to write' is obligatorily syllabified as onset on the first cycle : as a result, the initial g is part of the first syllable and can be linked to the prefixed CV slot of the reduplication unit. We obtain, before the insertion of e,

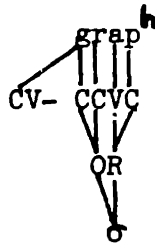

and , eventually, after e-Insertion and syllabification, ge.gra.p^ha.

A cluster not subject to correptio, like the initial gn of the root gnō 'to know', will consist, in the input to Linking , of an initial stray consonant followed by the syllable nō :

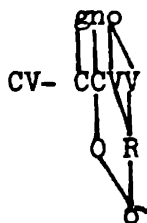

The Linking clause of the reduplication rule does not permit the association of the prefixed CV unit to stray segments like the initial g of gn̄ō. Since Linking fails, after g-Insertion and syllabification, we obtain eg.n̄ō.ka.

The absence of *e-grap^ha variants to ge-grap^ha shows that correptio clusters like gr are obligatorily tautosyllabic.

In the last chapter we assumed that the root initial clusters that cannot be syllabified as onsets are stray on the first cycle. The analysis of perfect reduplication requires some structural difference between the correptio clusters and the other root initial consonant sequences. But it is not immediately clear that it dictates the particular difference in structure we have assumed. Having introduced in the preceding section the three alternatives to the account previously assumed, we may examine now their contribution to the analysis of perfect reduplication.

In making precise the onset hypothesis represented in (3.a) I adopt a slightly modified version of the onset structures introduced by Cairns and Feinstein (1982) :

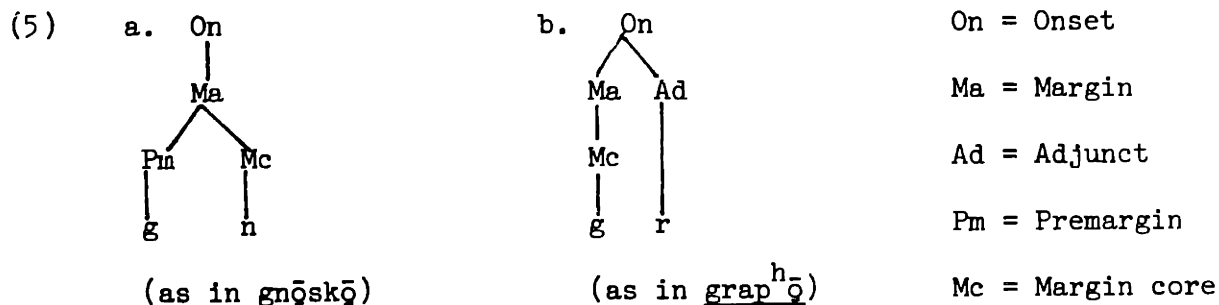

The theory of onset structures that goes along with these labels will have to be modified somewhat, since it stipulates that the adjunct, the margin core and the premargin dominate closed and disjoint sets

of segments (liquids for the adjunct, stops for the margin core and s or nasals for the premargin) : this aspect of the Cairns-Feinstein theory of onset structure is clearly contradicted by the fact that stops like g occupy a different structural position in Greek depending on whether they are followed by a high sonority consonant, like r, or by any other consonant. But the central idea that the syllable onset branches into distinct constituents, like the margin with its premargin and margin core, seems to be compatible with the essentials of our analysis of perfect reduplication. There is however a cost attached to translating rule (4) into a format where heterosyllabic initials are represented as in (5.a) : the Linking clause of the reduplication rule will have to be changed as below :

(6) Linking - onset premargin format

Associate the CV slots left to right to the melodic core of the first syllable beginning with the margin core.

In analogous fashion, the appendix and degenerate syllable hypotheses will have to replace the Linking clause of the reduplication rule with the statements in (7) and (8) respectively :

(7) Linking - appendix format

Associate the CV slots left to right to the melodic core of the first syllable beginning with the onset.

(8) Linking - degenerate syllable format

Associate the CV slots left to right to the melodic core of the first syllable that has a nucleus.

2.2. Loss of interconsonantal s, resyllabification and reduplication

In chapter 3, section 5.3.2. we attributed to the failure of syllabification the simplification of underlying /^heps-to-s/, /CV-grap^h-st^hai/ to h_{ep}t^hos and gegrap^ht^hai. This indicates not only that p^hs is not a possible coda in Greek but also that st^h, a heterosyllabic initial, is not a structure available word medially. The asymmetry between word medial and word peripheral position was attributed in chapter 3 to the existence of two extrametrical positions in the Greek word template : an initial extrametrical C and a final extrametrical s.

A fact which seems related to the exclusion of extrametrical consonants from non-peripheral positions in a syllabification domain is the obligatory heterosyllabic assignment of a heterosyllabic initial when postvocalic : one might suppose that word and phrase medially such clusters must be assigned to regular syllabic nodes. The loss of s and the resyllabification of the initial clusters in (9) (repeated from (6) in chapter 3) will then follow :

- (9) a. para gnōmēn 'contrary to expectation' : pa.rag.nō.mēn
 b. apo-ptusās 'spitting' : a.pop.tu.sās
 c. to k^hsi^hp^hos 'the sword' : tok^h.si.p^hos
 d. ta skeuē 'the utensils' : tas.keu.ē

The syllabic assignments recorded above would seem to allow a simplification of the Linking clauses in (6)-(8). If the heterosyllabic initials are resyllabified in forms like e-gnō-k-a (= eg.nō.ka),

e-spar-mai (= es.par.mai), e-kton-a (= ek.to.na) before the Linking clause of the reduplication rule, that clause could be simplified to :

(10) Linking clause : all formats if syllabification precedes it.

Associate CV slots left to right to the melodic core of the next syllable.

A comparative derivation of gegrap^ha and egnōka which follows this scenario is provided below . Notice that the four theories of heterosyllabic initials outlined above will be equivalent for reduplication if it turned out that (10) is the correct linking condition

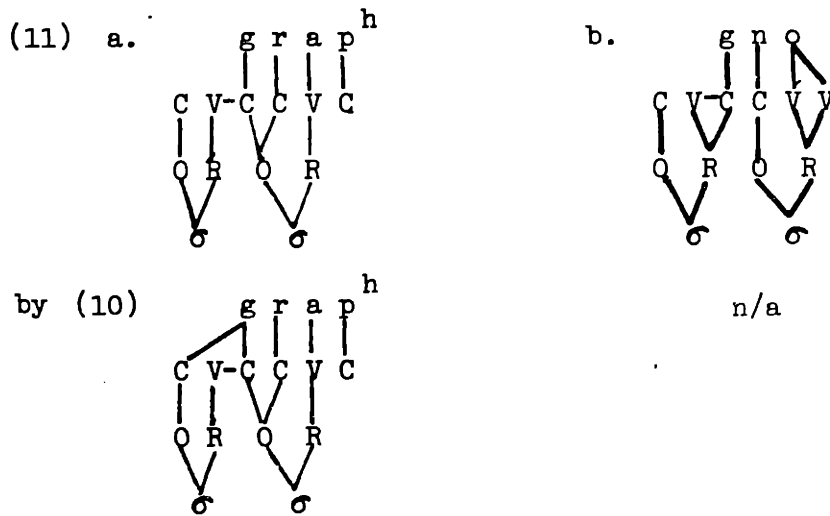

I show in the top half of (11) the output of CV prefixation and resyllabification: the heterosyllabic initial gn has resyllabified with its first member as the coda of the preceding syllable, while the 'regular' onset gr has not. When linking now applies, the g of gn is part of the initial syllable and, for this reason, inaccessible to linking by (10). The g of gr, on the other hand, is still in the onset position of the next syllable: it can therefore be

associated to the prefixed C in the reduplication syllable.

In fact, however, it is necessary to maintain the Linking clause of the reduplication rule in its original form (4.b) (or (6)-(8), for the alternative representations of heterosyllabic initials). The argument is based on the reduplication of vowel initial roots like op^hēl, perfect ōp^hēlēka. The initial long lax vowel of ōp^hēlēka results from the linking of the V slot in the reduplication prefix CV to the first root segment. If syllabification follows linking, as the initial version of the rule assumed, then the structure created by linking,

(12)

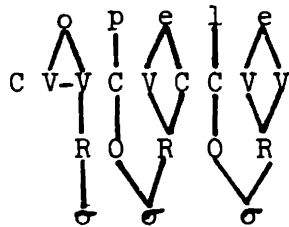

an o attached to two V slots, will be incorporated into the initial syllable, in accordance with the fact that the two V units of a doubly attached vowel are tautosyllabic in Greek. A tautosyllabic sequence of two V slots attached to a single vowel is, as we have shown in chapter 2 (section 6), the representation of long lax vowels:

(13)

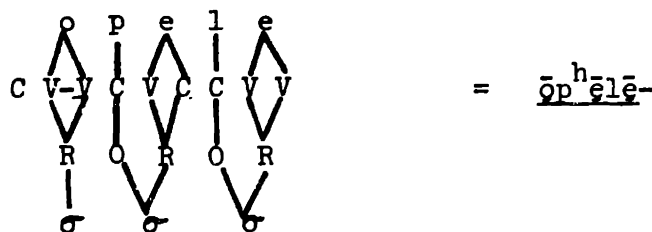

The order linking < syllabification can therefore derive the correct representation of the long lax vowels in perfect stems like $\bar{o}p^h\bar{e}l\bar{e}$ -. But the opposite order, syllabification < linking, on which (10) relies, cannot: the output of syllabification on the reduplication cycle will be, in a derivation where linking followed syllabification,:

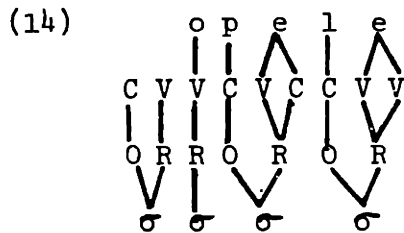

Linking will create structures like (15):

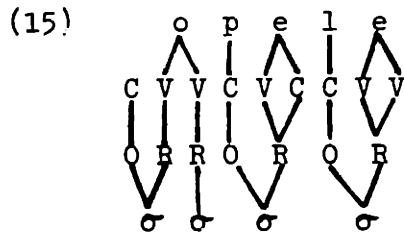

Any outcome of (15) will now fail: Contraction may apply to the sequence of adjacent rimes, but the output of contraction is a tense vowel if the input contained mid vowels (cf. $\bar{e}d\bar{o}$ 'you gave-MIDDLE' from underlying /e-do-so/ through loss of intervocalic \bar{e} and contraction of the adjacent $\bar{o}\bar{o}$ sequence). Or else Contraction may fail to apply, as in the epic dialect, in which case (15) is, for all relevant purposes, the end of the derivation. But reduplications like $*\bar{o}op^h\bar{e}l\bar{e}ka$ are never encountered in any Greek dialect, whether its contraction rule is obligatory or not.

In view of this problem, we need not dwell too long on the fact that the order prefixation < syllabification < linking inserts syllabification, a distinct rule or sequence of rules, in the middle of the reduplicating process. Nor is it necessary to insist that, as a general rule, syllabification processes are not blind to the segmental contents of the CV slots they give structure to, as the adoption of (10) would require them to: the discussion of coda structure in the last chapter has provided clear evidence that the assignment of a C slot to either the onset or the rime node depends on its segmental properties. This fact is also incompatible with the order assumed by (10).

The conclusion of this section will then be that the original versions of the Linking clause must be maintained: (4.b) in the stray-consonant format, (6) for the onset hypothesis, (7) for the appendix hypothesis and (8) for the degenerate syllable hypothesis. So far, the onset, appendix and degenerate syllable hypotheses seem, at best, clumsier notational variants of the stray consonant theory.

3. Heterosyllabic initials in Sanskrit

3.1. Reduplication

Like Greek Sanskrit has two patterns of perfect reduplication: one for verbal roots that begin with either a single consonant or with a certain type of consonantal cluster, which includes, but is not limited to, the onset clusters of Greek. The other pattern of perfect reduplication is restricted in Sanskrit to verbs whose initials consist of a continuant obstruent followed by a stop.

Let us experiment with the idea that the latter class of perfect reduplications reflects the behavior of the heterosyllabic initials of Sanskrit. If so, all consonant sequences that reduplicate according to the single C pattern will have to be assigned the structure of regular onsets. We see in (16) that they include many clusters that could not be tautosyllabic in Greek:

(16) Tautosyllabic initials

	Stem	Perfect Stem	
a.	C	tud	tu-tud 'to push'
		rud ^h	ru-rud ^h 'to obstruct'
b.	C C	prac ^h	pa-prac ^h 'to ask'
	$\begin{array}{c} \\ [-\text{son}] \\ \\ [-\text{cont}] \end{array}$ $\begin{array}{c} \\ [+ \text{son}] \end{array}$	āru	du-drav 'to run'
		jñā	ja-jñā 'to know'
		glā	ja-glā <3> 'to be weary'
		d ^h mā	da-d ^h mā 'to blow'
c.	C C	sniḥ	si-ṣniḥ 'to be sticky'
	$\begin{array}{c} \\ [-\text{son}] \\ \\ +\text{cont} \end{array}$ $\begin{array}{c} \\ [+ \text{son}] \end{array}$	smi	si-ṣmi 'to smile'
		sru	su-ṣru 'to flow'
		syand	si-ṣyand 'to move on'
		śrat ^h	śa-śrat ^h 'to slacken'
d.	C C	ksam	ca-ksam 'to endure'
	$\begin{array}{c} \\ [-\text{son}] \\ \\ [-\text{cont}] \end{array}$ $\begin{array}{c} \\ [-\text{son}] \\ \\ +\text{cont} \end{array}$	ksip	ci-ksip 'to throw'
		tsar	ta-tsar 'to approach stealthily'
		psā	pa-psā <3> 'to devour'

e.	$\begin{array}{c} \text{C} \\ \\ \text{m} \end{array}$	$\begin{array}{c} \text{C} \\ \\ [+son] \end{array}$	mluc	mu-mluc	'to set'	
			mnā	ma-mnā <3>	'to note'	
			myaks	mi-miks	'to be situated'	
f.	$\begin{array}{c} \text{C} \\ \\ \text{v} \end{array}$	$\begin{array}{c} \text{C} \\ \\ [+son] \\ [+cont] \\ [+cor] \end{array}$	vyac	vi-vyac	'to extend'	
			vyad ^h	vi-vyad ^h	'to pierce'	
			vraj	va-vraj	'to proceed'	
g.	$\begin{array}{c} \text{C} \\ \\ [-son] \\ [-cont] \end{array}$	$\begin{array}{c} \text{C} \\ \\ [-son] \\ [+cont] \end{array}$	$\begin{array}{c} \text{C} \\ \\ [+son] \end{array}$	ksnu	cu-ksnu	'to whet'

(17) Heterosyllabic initials

$\begin{array}{c} \text{C} \\ \\ [-son] \\ [+cont] \end{array}$	$\begin{array}{c} \text{C} \\ \\ [-son] \\ [-cont] \end{array}$	skand	ca-skand	'to leap'
		stu	tu-stu	'to praise'
		st ^h ā	ta-st ^h ā	'to stand'
		spr ^h d	pa-spr ^h d	'to contend'
		sp ^h ut	pu-sp ^h u	'to burst'
		ścut	cu-ścut	'to drip'

A comparison of (16)-(17) with the Greek facts tells us that Sanskrit differs in at least two respects from Greek: the inventory of 'regular' onsets is much richer, and the rule of reduplication involves copying of the root melodic core rather than linking to it.

The fact that the prefix CV of the reduplication unit is segmentally filled by copying the root melody can be observed by comparing the perfect forms of the roots tud, smi and mnā: tu-tud, si-smi, ma-mnā. The V slot of the reduplication prefix reflects a vocalic segment that belongs to the root. Linking the CV prefix to melody elements of the root will not achieve this result without

crossing association lines:

- (18) a. * tud
CV-CVC
- b. * smi
CV-CCV
- c. * mna
CV-CCVV

The solution is to copy the root melody:

- (19) a. tud tud
CV - CVC
- b. smi smi
CV - CCV
- c. mna mna
CV - CCVV
- tud tud
CV - CVC
- smi smi
CV - CCV
- mna mna
CV - CCVV

The perfect reduplication rule of Sanskrit can now be stated as in (20), a formulation which differs minimally from the one required for Greek:

(20) Sanskrit perfect reduplication

a. Prefixation.

Prefix CV.

b. Copying.

Copy the root melodic core associated with the root syllables.

c. Association

Associate left to right CV slots to the melody.

The derivations in (21) show that the rule (20) accounts not only for the difference in vocalism between reduplication of, say, Greek le-lūka and Sanskrit tu-tude but also for the different treatment of heterosyllabic initials: Greek e-sparmai vs. Sanskrit pu-sp^hota.

The derivations below assume that the root is syllabified in the input to the reduplication cycle and make use of the syllabic structures dictated by the stray consonant hypothesis.

(21) a. tu-tud b. si-smi c. tu-stu

input to
reduplication

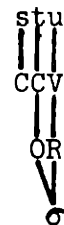

(20.a)

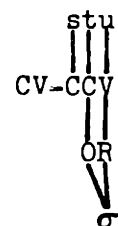
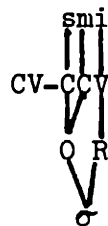
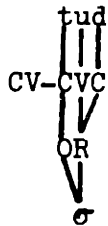

(20.b)

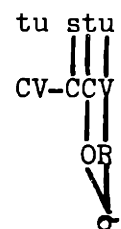
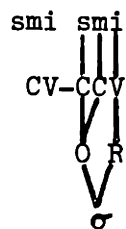
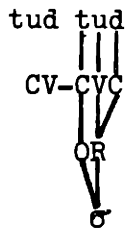

(20.c)

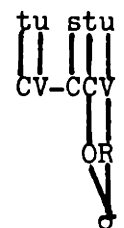

syllab.

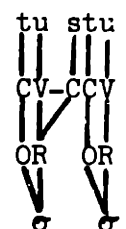

The essential detail in the derivations in (21) is the

application of the copying clause (20.b) to the root stu, syllabified



Because the initial s is stray, it cannot be copied as part of the first syllable. This is why the reduplication of heterosyllabic initials in Sanskrit skips over the first member of the cluster. The difference between Greek e-sparmai and Sanskrit tu-stu follows from the fact that in Greek the CV prefix receives its segmental specifications by linking to the next syllable's melodic core, whereas in Sanskrit the CV prefix is segmentally 'filled' by copying. In Greek, the linking provision does not allow associating the prefixed C to the stray initial s, and the crossing lines prohibition prevents linking the C to any segment found to the right of s. In Sanskrit, the copying clause cannot copy the initial stray s, but nothing prevents copying the rest of the root's melodic core.

Thus the difference between the vocalism of the reduplicating syllable in Greek and in Sanskrit dictates a statement of the reduplication rule which also turns out to explain why heterosyllabic initials are treated differently in the two languages.

Rule (20) assumes, as mentioned, the structures imposed on heterosyllabic initials by the stray consonant hypothesis. If stu is given an onset-premargin analysis, an appendix or a degenerate syllable analysis, the copying clause of rule (20) will apply

incorrectly to copy the entire initial cluster:

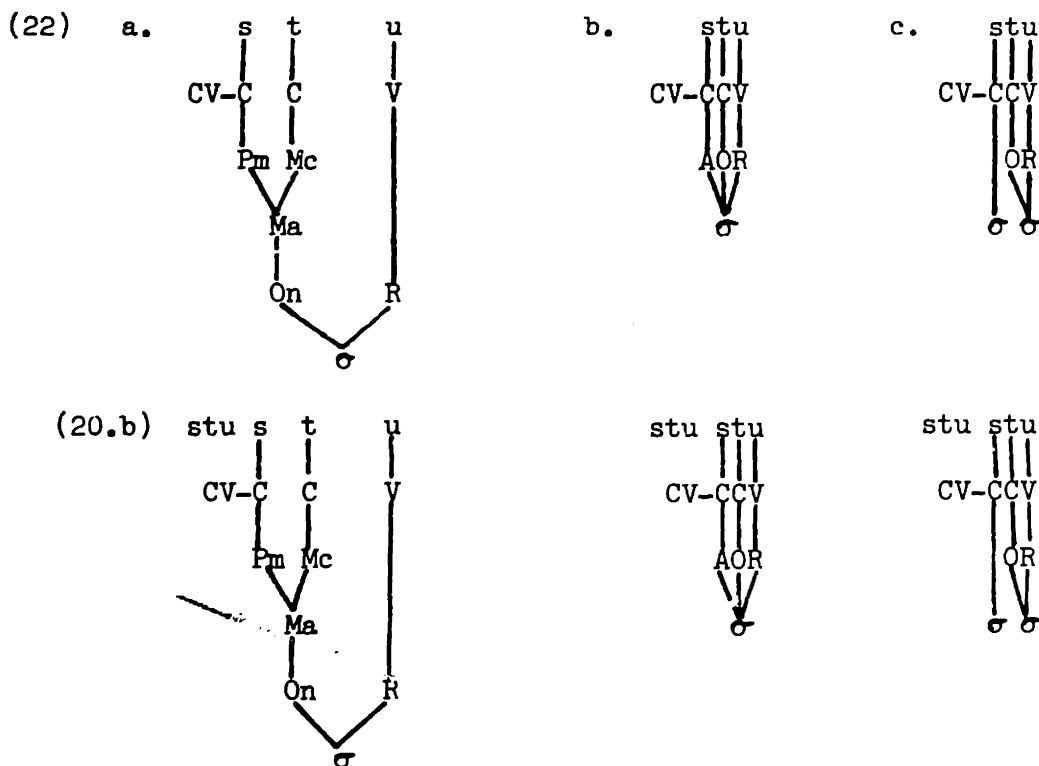

Left-to-right linking of the prefixed CV slots to the melody will produce *su-stu, as in the case of si-smi. We must therefore change the copying clause of the rule for each of these alternatives to the stray C analysis:

(23) Copying - onset premargin format

Copy the root melodic core associated with the root margin core and rime.

(24) Copying - appendix format

Copy the root melodic core associated with the root onset and rime.

(25) Copying - degenerate syllable format

Copy the root melodic core beginning with the first syllable that has a nucleus.

All these statements have to exclude, explicitly or not, copying the first member of a heterosyllabic initial, whether it is called pre-margin, appendix or degenerate syllable.

It appears then that a situation parallel to that uncovered in Greek obtains in Sanskrit : while the stray consonant analysis allows a formulation of the reduplication rule which does not have to mention specific constituents of the syllable in order to correctly differentiate the two classes of initial clusters, the alternative hypotheses have either to mention explicitly the syllabic nodes stipulated ad hoc or they have to list the complement set of syllabic constituents.

Is it possible to obviate this problem by assuming, for Sanskrit at least, that syllabification of the prefixed CV unit precedes copying of the root melody ? As in Greek, if this assumption could be sustained , the input to Copying would be structures like

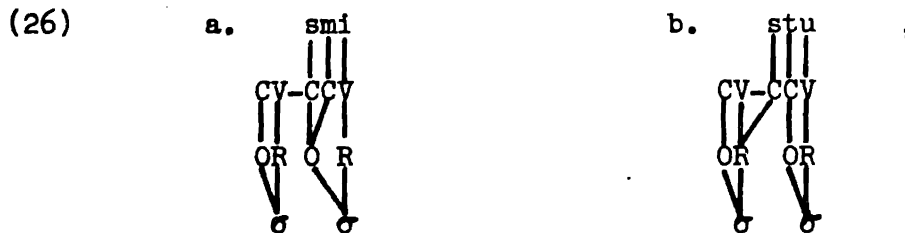

in which the resyllabification of the heterosyllabic initial as coda of the preceding syllable will permit any theory of syllable structure to take advantage of the Copying clause in its original formul-

ation (20.b). Copying applied to such structures will yield the correct difference between (27.a) and (27.b) :

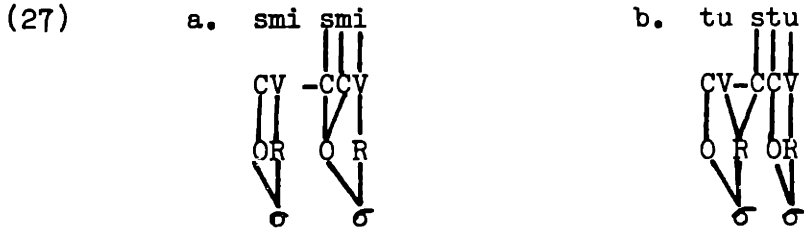

I am not aware of a Sanskrit problem similar to that raised in Greek by the order syllabification < Linking. A different objection can however be invoked against the possibility of a segmentally blind syllabification required by such an ordering. Thus, suppose that the unit prefixed by the reduplication rule was CVC rather than CV : the assumption that syllabification precedes the segmental filling of the skeleton slots will require setting up structures like (28) :

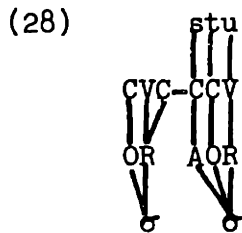

The empty V slot and the C slot which immediately precedes it could be assigned rime and onset status before their associated segments were known. But without knowing the segments that fill the last C slot, syllabification could not proceed in languages like Greek and Sanskrit , where both complex onsets and codas must satisfy condi-

tions of relative sonority and segmental linking (on the relative sonority conditions that must be met by Sanskrit codas, see below). In particular, the initial segment of a root like stu could not be resyllabified as the coda of the preceding syllable in (28) without regard to the segmental contents of the preceding C. For any theory other than the stray C theory an unresyllabified first member of a heterosyllabic initial is still part of the first root syllable, and thus available for Linking or Copying, exactly like the first member of a regular branching onset. This means that a clause like (20.b) will be able to copy the entire root melody stu in the structure shown in (28). The predicted reduplicated stem will be sū-stu-, that is,

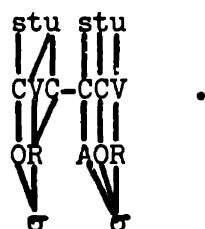

Thus, for the hypothesis that syllabification precedes Linking or Copying, the difference manifested between heterosyllabic initials and branching onsets with respect to reduplication in Greek and Sanskrit is an accident due to the fact that the reduplicating unit is CV , not CVC. Had it been CVC, both roots like stu and roots like smi would reduplicate in identical fashion. This seems an absurd result, and, for the reader who does not share this intuition, it is also a provably wrong one , as the Sanskrit pattern of intensive reduplication shows .

Whitney (1889 : paragraph 1000-1003) gives the following rules for intensive reduplication : the reduplicating unit consists of either (a) a CVV sequence ; (b) a CVC sequence ; (c) a CVCi or CVCī sequence . In all three cases, the segmental contents of the first three slots are determined by the root melodic core. Examples follow :

(29)	root	intensive	
a.	vad	vā-vad	'to speak'
	śvas	śā-śvas	'to blow'
	tij	te-tij	'to be sharp'
		(intermediate tai-tij)	
	sku	co-sku	'to tear'
		(intermediate cau-sku)	
	stāb ^h	tā-stāb ^h	'to prop'
b.	car	car-car	'to move'
	kram	can-kram	'to stride'
	stan	tan-stan	'to thunder'
	bād ^h	bad-bād ^h	'to oppress'
c.	gam	ganī-gam	'to go'
	grah	gari-grah	'to seize'
	dyut	davi-dyut	'to shine'
	skand	cani-skand	'to leap'

Whitney also notes that the (b) pattern, type car-car, is generally restricted to roots ending in consonantal sonorants. Bad-bād^h is then

an exception to this rule.

What all three patterns have in common is that the reduplicating unit is heavier than a CV syllable : it is either a heavy syllable or a disyllabic sequence CVCī or CVCi. The other common feature is that the first vowel of the reduplicating unit is underlyingly a : this is most clearly seen when we compare the perfect reduplication of the root dyut , di-dyut- , with the intensive reduplication davi-dyut-. Accordingly, I propose the following representation for the intensive prefix :

(30) CVC(V(V))
 $\begin{array}{c} | \quad / \\ a \quad i \end{array}$

The differences between vā-vad-, te-tij-, car-car- and davi-dyut- will then be derived as below :

(31) a. $\begin{array}{c} \text{vad} \quad \text{vad} \\ | \quad | \quad | \quad | \\ \text{CVC-CVC} \\ | \\ a \end{array} = \text{vā-vad}$

b. $\begin{array}{c} \text{tij} \quad \text{tij} \\ | \quad | \quad | \quad | \\ \text{CVC-CVC} \\ | \\ a \end{array} = \text{tai-tij} \Rightarrow \text{te-tij}$

c. $\begin{array}{c} \text{car} \quad \text{car} \\ | \quad | \quad | \quad | \\ \text{CVC-CVC} \\ | \\ a \end{array} = \text{car-car}$

d. $\begin{array}{c} \text{diut} \quad \text{diut} \\ | \quad | \quad | \quad | \quad | \\ \text{CVCVY-CCVC} \\ | \quad / \\ a \quad i \end{array} = \text{davi-dyut}$

As we see in (31) there are two sources of difference between intensive forms : the selection of the short or long expansion of the intensive prefix , exemplified by the contrast between (31.a-c) and (31.d); and the choice between associating the second C slot of the intensive prefix with the second or the third root segment. Thus, in car-car and davī-dyut- the second C is associated with the third root segment, in vā-vad- and te-tij-, it is associated with the second root segment.

We may account for the relative rarity of intensives like bad-bād^h- by adding a clause requiring that obstruents may not be linked to a preconsonantal C slot. The intensive reduplication rule will then be, in its complete form :

(32) Intensive Reduplication

a. Prefixation

Prefix CVC(V(y))
 | |
 a i

b. Copying

Copy root melody associated with the first root syllable.

c. Association

Associate the copied melody left to right to the empty C slots subject to the following conditions : (1) an obstruent may not be linked to a preconsonantal C; (2) the second root segment may be disregarded in association.

Note now that the short expansion of the intensive prefix , CVC ,
 |
 a

is the test case for the hypothesis that the prefixed unit is syllabified before it acquires segmental content. Recall that the prediction of that hypothesis is that the melody copied to fill a CVC prefix, a closed syllable, will be the entire root melody, with no distinction maintained between branching onsets and heterosyllabic initials. We observe however no difference between the three patterns of intensive reduplication in the treatment of heterosyllabic initials: the first member of a s-stop cluster fails to be copied regardless of whether the prefix ends in a closed syllable (tan-stan-) or not (co-sku-, cani-skand-).

A similar argument can be constructed for Greek, although the relevant word formation process is far less productive than the Sanskrit intensive. Certain Greek nominal roots are subject to a process of CVC reduplication from which words like barbaros 'one who speaks a language other than Greek', mermeros 'baneful deed, mischief', porp^hurā 'purple dye' result <4>. The one clearly attested case of nominal CVC reduplication applying to a heterosyllabic initial root is kaskandik^hs, glossed by Hesychius as gēt^hullis 'spring onion'. Kaskandik^hs is the CVC reduplication of the nominal root in skandik^hs 'wild chervil'. Intermediate kan-skandik-s becomes kas-skandik-s by the gemination rule which derives sus-skeuazzō (eventually suskeuazzō) from /sun-skeuad-y-ō/: this is an extension of rule (24) of chapter 2. Kasskandik-s is then regularly simplified to kaskandik-s, eventually kaskandik^hs. The derivation of this form is considered below:

(33) input to
reduplication



Prefix CVC

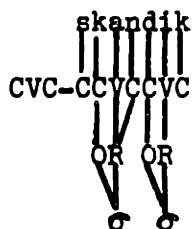

Copying
(as in (32.b))

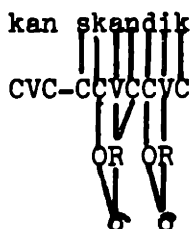

Association
(as in (20.c))

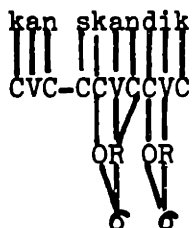

Syllabification

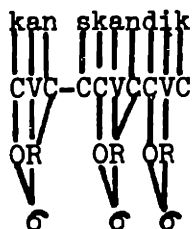

Gemination

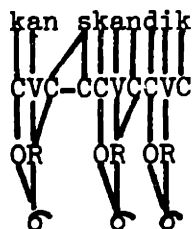

(33) continued

Stray Erasure

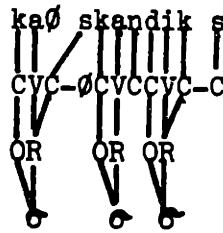

The derivation in (33) assumes the structures assigned by the stray C analysis of heterosyllabic initials and the order syllabification < Copying. If the order of operations is reversed and if sk contains a syllabically attached initial s, as in (34) for example,

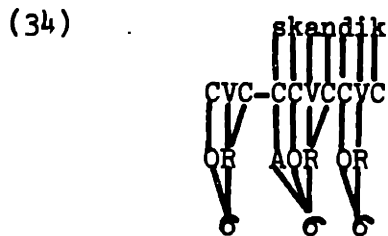

then resyllabification of the initial s will not apply, since the MSD condition on coda attachment cannot be met without information on the segmental specifications of the C slot that precedes it. Since the entire initial cluster sk remains tautosyllabic, Copying will apply to it, yielding

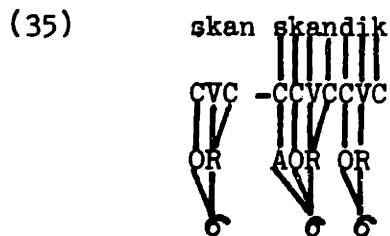

Association will now result in san-skandik- and the final predicted form will

be *saskandik^hs <5> .

I have illustrated above only the derivation of /CVC-skandik-s/ within the appendix format. Similarly wrong results follow under the onset premargin and degenerate syllable theories.

Thus we must conclude that heterosyllabic initials reduplicate according to the same principles : in Greek as well as in Sanskrit, whether the reduplicating unit is CV or CVC, only the second member of the cluster is available for Linking and Copying. Since the order syllabification < Linking or Copying predicts results that are contradicted by the available evidence , we must abandon it once again. This , in turn, means that the original statement of the reduplication rules of Greek and Sanskrit is upheld : we can use the Linking clause in (4.b) for the Greek perfect reduplication and the Copying clause (20.b) for the Sanskrit reduplications if we assume that the structures of heterosyllabic initials begin with a stray C. Otherwise, we must replace these statements with less elegant alternatives, as shown above.

3.2. Loss of interconsonantal s

Our only reason to believe that there are heterosyllabic initials in Sanskrit and that they include all and only s-stop clusters are the facts of reduplication. Our only basis for assuming that the onset structure of Sanskrit allows all the clusters listed in (16) is, again, the perfect and intensive reduplication.

This section will provide an additional argument that Sanskrit clusters like sk and sm differ in their possibilities for syllabic assignment.

The argument is based on the pattern of interconsonantal s loss, as it can be observed in the paradigm of the sigmatic (-s-) aorist.

Consonant final roots followed by the aorist suffix -s- take in Sanskrit some consonant initial endings. Underlying consonant sequences CsC are thus created. In Greek, where a preconsonantal s can never be part of an onset and where a postconsonantal s cannot be part of a coda, such sequences always result in the loss of the unsyllabifiable s. In Sanskrit, our analysis of perfect reduplication indicates that sm can be an onset, because a root like smi reduplicates according to the same pattern as tud or prac^h. The same analysis indicates that st cannot be an onset, because a root like stu follows a different reduplication pattern. All the reduplication facts in (16) - (17) can be interpreted as pointing to an onset structure that is governed by the Minimal Sonority Distance requirement in (36)

(36) Adjacent tautosyllabic consonants must be at least one interval apart on the sonority scale.

(36) requires the sonority scale in (37) :

(37)	[-son,-cont,-cor]	: p, k, b, g.
	[-son,-cont,↓cor]	: t, d.
	[-son,↑cont,↑cor]	: s.
	[↓son,-cont,↑nas, -cor]	: m.
	[↓son,-cont,↑nas, ↑cor]	: n.
	[↓son,↑cont,-nas, ↓lat]	: l
	[↓son,↑cont,-nas,-lat,-cor]	: w
	[↓son,↑cont,-nas,-lat,↑cor]	: r,y.

The reader can check against the list in (16) that even difficult clusters like sm, ml, wr, wy are correctly allowed as onsets by the conjunction of (36) and the sonority scale in (37). It is also worth pointing out that no special provisions are made for cases like wr or wy : they follow from the introduction in the sonority scale of Sanskrit of the coronality feature , a move required in any case by the existence of onset clusters like mn <6>.

Returning now to the underlying CsC clusters of Sanskrit, the unmarked expectation is that they will be syllabifiable if at least one of the two consonants flanking s are one or more intervals higher on the scale in (37) than s : if Cs is a sequence of decreasing sonority then it is a possible coda; if sC is a sequence of increasing sonority then it is a possible onset. The only case in which the interconsonantal s will be unsyllabifiable is if both the preceding and the following consonants are of lower or equal sonority : for such a case we predict loss of s , as in the by now familiar examples of Greek.

The prediction can be verified by looking at the sigmatic aorists of sonorant and obstruent final roots, when followed by sonorant and obstruent initial endings. I cite below the rule given in Whitney (1889 : paragraph 881). The reader should bear in mind that the only relevant obstruent initial endings begin with t or t^h :

"Before endings beginning with t or t^h the tense sign s is omitted after the final consonant of a root - unless this be r or n or m (...)"

(38) continued

śap-ta ←= /śap-s-ta/

'you cursed'

Beside confirming our hypothesis about the onset structure of Sanskrit the facts of interconsonantal s-loss also show that, as in Greek, the permissible coda clusters are mirror images of the permissible onset clusters : we had assumed that this is so, in formulating the Sanskrit MSD as in (36) and this assumption is now verified.

The onset and coda rule of Sanskrit can now be stated as below :

(39) a. Onset rule

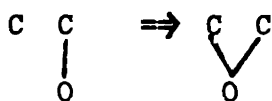

subject to (36)

b. Coda rule

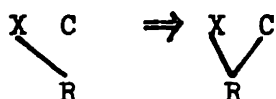

subject to (36)

The rules are identical to those of Attic Greek, stated in (34), Chapter 3 : all surface differences between the onset and coda inventories of Attic and Sanskrit follow from the different MSD requirements which govern their syllabic adjunction rules. This includes the difference in the number of times the onset or coda rules may iterate in the two languages : there are no more than two positions on the sonority scale of Attic that are separated by 4 intervals and thus only 2 iterations of the onset and coda rules will have results conforming to the Attic MSD requirement. In Sanskrit the required MSD is of only one interval

on the sonority scale in (37), which in principle allows onsets and codas of up to 8 consonants. That such clusters are not attested we may safely attribute to extragrammatical factors : what is significant is that triconsonantal onsets like k_̣sm, k_̣sn, k_̣sv are attested in Sanskrit, whereas in Greek of the first millenium such onsets are impossible. We will see in the next section that Common Greek, whose MSD requirement and sonority scale are almost identical to those of Sanskrit, allowed onsets like k_̣tr, n_̣wy, p_̣try, involving up to four iterations of the onset rule.

4. Heterosyllabic initials in second millenium Greek

4.1. Mycenaean spelling conventions

What follows is an analysis of the onset structure of the earliest attested dialect of Greek, the language of the Linear B documents. Its task is to provide further confirmation for the reconstruction of Sanskrit onset structure presented above; to develop a distinct argument that the first member of a heterosyllabic initial is not part of the initial syllable ; and to give the background for the discussion of another syllable initial process relevant here : the Common Greek g \Rightarrow h rule.

What will be shown in this section is that if we assume (36) and the sonority scale in (37) as holding for Mycenaean we can explain essentially all the facts of the Linear B spelling conventions.

The writing system of the Linear B documents is syllabic rather than alphabetic : each sign stands for a syllable rather than for a

sound. But there were not as many signs in the Linear B as there were syllables in the dialect of Greek recorded by that script. Only CV and V syllables have corresponding signs <8>. In order to spell out the consonant clusters, the following convention was adopted:

- (40) a. Onset clusters are broken up by inserting after each member of the cluster not immediately followed by the nucleus, a copy of the first vocalic sign to its right. The CV units thus obtained are spelled out by the available CV signs.
- b. All other consonants are omitted.

The spelling convention in (40) is based on the interpretation of examples like those given below :

- (41) a-to-ro-qa (= an.t^hro.k^wos) : alphabetic Greek ant^hrōpos 'man'
ti-ri-po-de (= tri.po.des) : alph. Gk. tripodes 'tripeds'
ka-ko (= k^hal.kos) : alph. Gk. k^halkos 'bronze'
a-ku-ro (= ar.gu.ros) : alph. Gk. argūros 'silver'
ku-ru-so (= k^hru.sos) : alph. Gk. k^hrūsos 'gold'

The tautosyllabic assignment of stop-liquid clusters can be taken for granted ; similarly, intervocalic sonorant-stop sequences can be assumed to have been heterosyllabic in Mycenaean, as elsewhere in Indo-European languages. These assumptions and the conventions postulated in (40) explain the spellings ti-ri, to-ro, ku-ru of the onset clusters tr/i, tr/o, k^hr/u .

When extended to other clusters, the spelling convention (40) reveals that Mycenaean had an onset structure almost identical to that of Sanskrit : we find not only that the stop-nasal clusters are spelled according to (40.a) but also that the mn, sm, ks, ksm, wr , wy sequences which are tautosyllabic in Sanskrit are subject to the same clause. We also find some clusters predicted to be tautosyllabic by the conjunction of (36) and (37) but not actually attested in Sanskrit: pt, kt, nw, nwy, ktr . A rather striking confirmation of the sonority scale set up for Sanskrit is the fact that . in minimal contrast to nw sequences, which are tautosyllabic, rw clusters are provably heterosyllabic in Mycenaean, as some of the examples below will indicate :

(42) Biconsonantal onsets

<p>a. [-son, -cont] [↓son]</p> <p style="margin-left: 40px;"> </p> <p style="margin-left: 40px;">C C</p>	<p>: A.le.ksan.dra <a-re-ka-sa-da-ra></p> <p>me.le.tri.yai <me-re-ti-ri-ja></p> <p>'miller-fem-pl'</p> <p>kla.wi.p^ho.ros <ka-ra-wi-po-ro></p> <p>'key-bearer'</p> <p>A.kmo.ni.yos <a-ko-mo-ni-jo></p> <p>po.tni.ya <po-ti-ni-ja></p> <p>'lady'</p> <p>kna.p^heus <ka-na-pe-u></p> <p>'cloth dresser'</p> <p>s.t^ha.tmos <ta-to-mo></p> <p>'farmstead'</p>
--	--

(42) continued

		te.tu.k ^h wo.h ^h a	<te-tu-ko-wo-a ₂ >
		'garments'	
b.	[-son, †cont][†son] :	de.smos	<de-so-mo>
		'fitting'	
	C C	do.smi.ya	<do-si-mi-ja>
		'gifts'	
c.	[-son, -cont] [-son, †cont] :	to.kso.wor.goi	<to-ko-so-wo-ko>
		'bow workers'	
	C C	de.ksi.wos	<de-ki-si-wo>
		'right'	
		de.ksa.to	<de-ka-sa-to>
		'received'	
		k ^w si.p ^h os	<qi-si-po>
		'sword'	
d.	[-son] [-son] :	te.kton	<te-ko-to>
	[-cont] [-cont]	'builder'	
	[-cor] [†cor]	pte.ie.wa	<pte-re-wa> <10>
		'elm'	
	C C	di.p ^h t ^h e.ra	<di-pte-ra>
		'skin'	
		pto.le.ma.tas	<po-to-re-ma-ta>
		'warrior'	
e.	[-son] [-son] :	A.mni.sos	<a-mi-ni-so>
	[-cont] [-cont]	de.mni.ya	<de-mi-ni-ja>
	[-cor] [†cor]	'bedsteads'	
	C C		

(42) continued

f.	$\begin{bmatrix} \uparrow\text{son} \\ -\text{cont} \\ \uparrow\text{cor} \\ \\ \text{C} \end{bmatrix}$	$\begin{bmatrix} \uparrow\text{son} \\ \uparrow\text{cont} \\ -\text{cor} \\ \\ \text{C} \end{bmatrix}$:	<p>pe.ru.si.nwos <pe-ru-si-nu-wo> 'of last year' kse.nwos <ke-se-nu-wo> 'foreigner' <ke-se-nwo></p>
g.	$\begin{bmatrix} \uparrow\text{son} \\ \uparrow\text{cont} \\ -\text{cor} \\ \\ \text{C} \end{bmatrix}$	$\begin{bmatrix} \uparrow\text{son} \\ \uparrow\text{cont} \\ \uparrow\text{cor} \\ \\ \text{C} \end{bmatrix}$:	<p>wri.ne.yos <wi-ri-ne-jo> 'of leather' wriz.za <wi-ri-za> <11> 'root'</p>

(43) Some heterosyllabic clusters

a.	$\begin{bmatrix} -\text{son} \\ \uparrow\text{cont} \\ \\ \text{C} \end{bmatrix}$	$\begin{bmatrix} -\text{son} \\ -\text{cont} \\ \\ \text{C} \end{bmatrix}$:	<p>P^hais.tos <pa-i-to> p^has.ga.na <pa-ka-na> 'swords' as.ke.tryai <a-ke-ti-ri-ja></p>
b.	$\begin{bmatrix} \uparrow\text{son} \\ \uparrow\text{cont} \\ \uparrow\text{cor} \\ \\ \text{C} \end{bmatrix}$	$\begin{bmatrix} \uparrow\text{son} \\ \uparrow\text{cont} \\ -\text{cor} \\ \\ \text{C} \end{bmatrix}$:	<p>kor.wos <ko-wo> 'boy' dor.we.yos <do-we-jo> 'of wood' p^har.we.^ha <pa-we-a₂> pieces of cloth'</p>
c.	$\begin{bmatrix} -\text{son} \\ -\text{cont} \\ \\ \text{C} \end{bmatrix}$	$\begin{bmatrix} -\text{son} \\ -\text{cont} \\ -\text{cor} \\ \\ \text{C} \end{bmatrix}$:	<p>p^hu.lak.p^hi <pu-ra-pi> <12> 'to the guardians'</p>

One other respect in which Mycenaean agrees with Sanskrit is the existence of triconsonantal onsets like ksm, ktr, nwy (the last two accidentally not attested in Sanskrit) : thus a₂-ka-sa-ma is interpreted as aiksma (alphabetic Greek aik^hmā 'sword') and the fact that k is spelled out indicates that it is part of the onset, therefore ai.ksmā ; re-u-ko-to-ro is interpreted as Leuktron, a place name, and must have been syllabified Leu.ktron, judging from the spelling; ke.se.nu.wi.ja may be interpreted kse.nwya 'gifts for guests'.

All the available evidence indicates therefore that Mycenaean had in common with Sanskrit the onset rule (39.a), the MSD requirement of one interval and the sonority scale in (37).

The Mycenaean spelling conventions provide us with one fact that is directly relevant to the analysis of heterosyllabic initials : word initial s-stop clusters are not spelled out in full. Rather, the initial s is omitted, as coda consonants are. This spelling is used regardless of whether the initial s in the cluster is preceded by a word that might make it eligible for resyllabification as a coda. Thus a phrase like toson sperma 'this much seed' as well as a phrase initial sperma will be spelled (to-so) pe-ma, never *se-pe-ma . Other examples of heterosyllabic initials are found in ta-to-mo, interpreted as stat^hmos 'farmstead', ke-re-a₂ interpreted as skele^ha 'legs of a tripod', pe-i interpreted as sp^heis 'they-DAT', pa-ko-we interpreted as sp^hakowens 'scented with sage'.

While the appendix and the degenerate syllable analysis can explain this fact, as the stray C analysis does, as following directly

from convention (40), the onset premargin analysis will have to revise (40) as below :

- (43) a. Onset clusters are broken up by inserting after each one of the members of the margin core a copy of the vocalic segment to its right. The resulting CV units are spelled out by the available CV signs.
- b. All other consonants are omitted.

I assume that the structure given to triconsonantal onsets like ksm by the premargin analysis will be as in (45) :

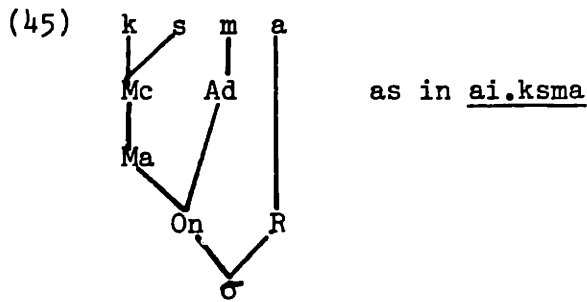

Since both k and s are members of the margin core, each receives its own copy of the nuclear vowel a and a₃-ka-sa-ma is thus obtained. The facts can once again be described but no explanation is given as to why the cluster ksm must be analyzed as a branching margin core followed by an adjunct rather than in any of the other conceivable ways.

4.2. The s \Rightarrow h rule in Common Greek

Mycenaean texts document the effects of a pair of related Common Greek sound changes : s became h before any sonorant, y became h before a vowel . The complete statement of the environment in which these sound changes occurred will occupy us in this section : when the proper syllable structure is assumed the two rules turn out to be one, stateable simply as :

(46) S and y became h syllable initially.

The syllable structure we need to assume in order to reduce the complex set of environments of the s \Rightarrow h, y \Rightarrow h rules to the syllable initial position has in fact been motivated for Sanskrit and Mycenaean.

To extend this analysis of syllable structure to Common Greek we need only make the minimal assumption that the onset structure of Mycenaean is identical to that of Sanskrit because the two are genetically related. If so, the syllable structure of any earlier stage of Greek - i.e. that of Common Greek - will have to be identical to that of Mycenaean and Sanskrit.

The environments in which s became h are listed below :

- (47) s \Rightarrow h / (a) # ___V sek^womai \Rightarrow h^{ep}omai 'I follow'
- (b) # ___ [+son] smia \Rightarrow h^mia \Rightarrow mia 'one-fem'
- |
C
- swekuros \Rightarrow h^wekuros \Rightarrow h^eekuros
- 'father in law'
- (c) V ___V nesomai \Rightarrow ne^homai \Rightarrow neomai
- 'I return'

(47) continued

iseros \Rightarrow i^heros \Rightarrow h^hieros 'holy'

(d) [+son]

C _____ V ekrinsa \Rightarrow ekrin^ha \Rightarrow ekrīna 'I judge' <13>

ansiā \Rightarrow an^hiā \Rightarrow h^hāniā 'rein'

(e) [+son] [+son]

C _____ C arsama \Rightarrow ar^hma \Rightarrow h^harma 'wheel, chariot'

(f) [+son]

V _____ C naswos \Rightarrow na^hwos \Rightarrow nāwos \Rightarrow nāos 'temple'

esmi \Rightarrow e^hmi \Rightarrow ēmi 'I am'

k^heslioi \Rightarrow k^he^hlioi \Rightarrow k^hēlioi (Dor.) 'thousands'

(48) s maintained intact :

(a) [-son]

_____ C spērō 'I sow', skeuā 'care'

(b) [-son]

C _____ V p^hsūk^hō 'I breathe', ak^hsios 'worth'

(c) [-son]

V _____ C astēr 'star'

(d) _____ # h^hek^hs 'six', nomos 'law'

Kiparsky (1967 : 633) notes that across certain suffixal boundaries the Common Greek sequence sn, sy (as in sbes-nū-mi 'I extinguish', aidos-yo-s 'shameful') become geminate nn, yy in all dialects. Forms which look like Aeolisms sbennūmi, aidoios (from intermediate aidoyyos) are attested in Ionic-Attic, while the expected sbēnūmi, aidōs are not to be found. We may develop as follows Kiparsky's suggestion that the regular s \Rightarrow h change was blocked in certain morphological classes :

Attic and maybe other dialects had the cyclic gemination rule in (49) :

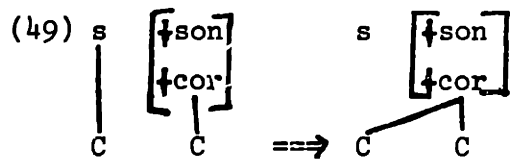

Rule (49) applied cyclically at level 1 only : that is before derivational affixes only and before present stem formants like -nū- . Recall from Chapter 3, section 5.5.4. that this present stem formant does not act as a level 2 suffix with respect to Sonorant Voicing : hence dēk-nū-mi (dē.knū.mi) rather than *dēg-nū-mi . The same level 1 /level 2 distinction between a suffix like -nū- and one like, say, -nai (the infinitive ending) is now of use in determining the coverage of the gemination rule in (49) : before -nū- , a level 1 morpheme, s undergoes (49), before -nai , a level 2 morpheme, it does not and yields, after the regular change to h , e^hnai \Rightarrow ēnai 'to be'. As a cyclic rule which applies in feature changing fashion, (49) fails to operate in morpheme internal position : hence selasnā \Rightarrow sela^hnā \Rightarrow selānā 'moon'. The apparent exceptions to the s \Rightarrow h rule (sbennūmi , aidoios) can be eliminated in this way.

If stated linearly, the set of environments listed in (47) requires the disjunction $\left\{ \begin{array}{c} \# \\ [+son] \end{array} \right\}$:

(50) $s \Rightarrow h / \left\{ \begin{array}{c} \# \\ [+son] \end{array} \right\} \text{---} [+son]$

But by now disjunctions of major class features and word boundaries have become clear indicators that the rule in question should be stated

in terms of syllable structure (cf. Lowenstamm 1982). In the particular case of the change of s to h the asymmetry in the placement of word boundaries - as left environment only - indicates that the proper locus of the rule is in syllable initial position.

An s- sonorant cluster is however not a tautosyllabic sequence in Attic or in any other first millenium Greek dialect : thus smia, esmi, esnai, k^heslioi, arsma , to the extent that their consonant clusters would be allowed to surface in alphabetic Greek, would be syllabified there s.mi.a (heterosyllabic initial), es.mi, se.las.nā, es.nai, k^hes.li.oi, ar.s.ma (unsyllabified middle s). Clearly, we cannot write a simple rule like (51) :

$$(51) \quad s \implies h / \text{[}$$

if we assume alphabetic Greek syllable structure.

The Sanskrit - Mycenaean syllabification rules in (39) will generate the correct syllabic divisions e.smi, e.snai, k^he.sli.oi, ar.sma. They will also predict that the s of stop - s clusters , as in p^hsūk^hō or ak^hsios will not be in syllable initial position and will therefore not meet the rule : the syllabic division enforced by the ordered sequence of rules in (39) is p^hsū.k^hō, a.k^hsi.os. Finally, the assumption that the s \implies h rule operated on syllabic structures generated by (39.a-b) explains why in Mycenaean the intervocalic sequence ksm is preserved intact in aiksmā (spelled a₃-ka-sa-ma): ksm was a complex onset in Common Greek , as it was in Mycenaean and

Sanskrit. Because s did not stand there in syllable initial position, it could not undergo the change to h during the second millenium : this is why it surfaces in Mycenaean. The fate of underlying ksm clusters in Attic was outlined in chapter 3, section 5.5.2.2.

If we adopt (51) we must assume that a root final s is tautosyllabic with the initial sonorant of the level 2 suffixes -mi (1st sg. active athematic ending), -mai (1st sg. middle), -nai (infinitive ending), in forms like es-mi , es-nai, ēs-mai . The required syllabifications e.smi, e.snai, ē.smai , necessary for these forms to meet the environment of rule (51), are in apparent contradiction with our conclusion that the onset rule ceases to apply at level 2 (chapter 3, section 6). Recall that Attic intermediate structures te-tuk^h-mai, pe-pēt^h-mai meet the heterosyllabicity conditions of the rule of Sonorant Voicing (which derives tetugmai) and of the [+cor] => s / m rule (rule (78), which derives pepēsmai), because the onset rule ceases to apply in Attic at level 2.

This is apparently not the case in Common Greek, as the required assignments e.smi, e.snai, ē.smai indicate. There is in fact good evidence for allowing the onset rule to apply beyond level 1, quite independently of the statement of the s => h rule.

The evidence comes from the Linear B spellings of perfect participles in -meno- and -wos- , both containing level 2 suffixes. Forms like pe-pi-te-me-no-jo, a-ra-ro-mo-te-me-no, e-ra-pe-me-na , te-tu-ko-wo-a₂ are interpreted as pepit^hmenoyo 'persuaded-GEN', ararmotmeno 'fitted' (on the spelling ro-mo see Lejeune 1972 : 285), errapmena 'sewn', tetuk^hwo^ha 'garments'. The syllabifications indicated

by the spelling could only have resulted from a level 2 application of the onset rule , as shown below :

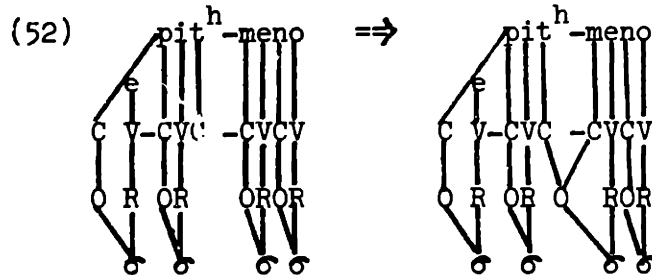

The application of rule (51) in es-mi, es-nai can be explained along the same lines : s occupied the syllable initial position in such forms, despite the intervening level 2 boundary, because the onset rule had applied to it at level 2.

Finally, the fact that the second half of a geminate s is never subject to (51) despite its syllable initial position , as in essetai 'will be' , the epic future of ēmi, can be attributed to the true geminate nature of the ss cluster . The autosegmental representation of essetai is

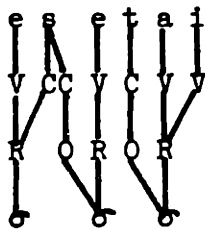

where the environment of the g => h rule is met by only the first of the two C's associated with s. Convention (22.b) of Chapter 1 will not allow rule (51) to apply unless both C's associated with s meet its description. This explains why dialects like Homer's, which lack

A simpler solution goes as follows : y became h only in inter-vocalic and initial prevocalic position. In postsonorant position it always underwent Metathesis : not only p^han-y-ō , mor-y-a and ewrew-y-a became p^hainō, moira, eureia but also krin-y-ō, p^ht^her-y-ō, olop^hur-y-ō became kriinō, p^ht^hēirō, olop^huirō. Contraction followed metathesis and ii became ī, ei became ē, as they always do in Attic. The ui sequence of forms like olophuirō became ū : this type of contraction is no less regular, even though less frequently attested, as forms like ik^ht^hūdion from /ik^ht^hu-idi-o-n/ 'little fish' indicate. In Lesbian and Thessalian , where p^hainō and moira coexist with olop^hurrō, krinnō, p^ht^herrō, the metathesis of the sonorant - y cluster applied only after a [-high, †back] vowel : elsewhere y was lost with resyllabification (the Aeolic rule (36) of Chapter 2) of the preceding syllable final consonant.

One can maintain in this way the relatively simple statement (53) of the conditions under which y became h in Common Greek.

We may now consider the central issues : what is the statement of the y ⇒ h rule and is it a single process with the s ⇒ h rule ?

The effects of both changes are Common Greek and both are attested in the Linear B documents : the relative pronoun yo- is spelled there half of the time as o- (i.e. h^{o-}) and half of the time jo- (i.e. yo-); the s of historical *t^heso- 'god' is already missing in te-o (i.e. t^he^hos), as is that of *isereus in i-je-re-u (i.e. i^hyereus) . Numerous other examples of s-less Mycenaean forms are to found in Lejeune 1972 : 96.

The formal similarities between the two rules are also considerable, although incomplete, when stated linearly. Once again, putting the proper syllable structure into the picture will allow us both to formulate a maximally simple statement of the change of y to h and to collapse it with rule (51). An onset rule like (39.a) will turn any sequence consisting of a consonant (other than r) followed by y into an onset : all consonants except r are less sonorous by at least one interval than y on the scale in (37). If we slightly modify the scale by introducing palatality distinctions we obtain the scale in (54) , on which all consonants, including r , are by at least one interval less sonorous than y and thus may precede y within the same onset :

- (54) [-son,-cont,-cor] : p, k, b, g.
[-son,-cont,+cor] : t, d.
[-son,+cont] : s, z.
[+son,-cont, +nas,-cor] : m.
[+son,-cont, +nas,+cor] : n.
[+son,+cont,-nas,+lat,+cor] : l.
[+son,+cont,-nas,-lat,-cor] : w.
[+son,+cont,-nas,-lat,+cor] : r.
[+son,+cont,-nas,-lat,+cor,+pal] : y.

In a language using the scale in (54) and the onset rule (39.a) y will never be syllable initial when preceded by a consonant. It will however occupy the syllable initial position at the beginning of a word when followed by a vowel and in intervocalic position - that is

in exactly the two positions where it became h in Common Greek.

The process of y \Rightarrow h is thus formally identical to the s \Rightarrow h rule :

both occurred in syllable initial position :

(55) Generalized y,s \Rightarrow h

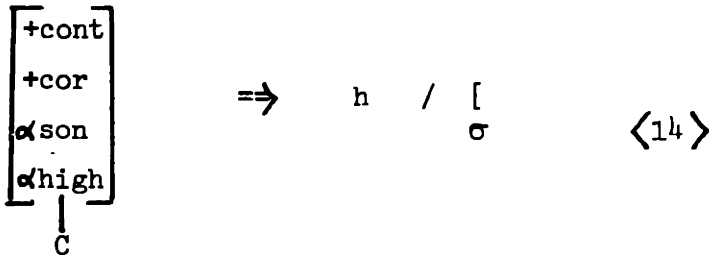

The modification introduced in the sonority scale in (37) in order to explain why any postconsonantal y, including y after r, fails to undergo (55) (as in mor-y-a \Rightarrow moira) turns out to be of use in explaining Linear B spellings like a-ke-ti-ra₂ alternating with a-ke-ti-ri-ja both interpreted as asketryai (as.ke.tryai) with a triconsonantal onset in the third syllable : the variation between the ti-ra₂ spelling and the ti-ri-ja spelling is attributed (for example by Lejeune 1972 : 156) to the fact that ra₂ spells out rya. If so, the ti-ri-ja : ti-ra₂ variation is entirely parallel to that between nu-wo and nwo (ke-se-nu-wo and ke-se-nwo for kse.nwos) or between du-wo and dwo (te-mi-du-we-ta and te-mi-dwe-ta for ter.mi.dwen.ta). Other instances of tautosyllabic ry are ra-pi-ti-ra₂ interpreted as ra.ptryai 'seamstresses' (note the quadriconsonantal onset !), a-ro₂-e interpreted as a.ryo.^hes 'better-NOMpl', po-pu-ro₂ interpreted as por.p^hu.ryos 'purple-colored'.

The spelling evidence and the phonological facts are once again found to support each other.

This concludes our reconstruction of the conditions under which s and y became h in Common Greek. We have seen that both changes occurred in syllable initial position, as defined by the syllabic assignments indicated by the Mycenaean spelling conventions. The heterosyllabic initials s-stop were not affected by the rule : stat^hmos, spērō, skelos did not lose their initial s. Although in word initial position, s did not occupy the syllable initial position in such clusters : according to the stray C analysis of heterosyllabic initials, the s of such sequences did not belong to any syllable.

4.3. Archaic reduplications

Mycenaean spelling conventions and rule (55) converge on a reconstruction of the Common Greek onset structure that is almost the same as that reconstructed in section 3 for Sanskrit. The one point of difference concerns the ry clusters, unattested as onsets in Indic but shown to have been tautosyllabic in Common Greek and Mycenaean. The two syllabification systems are otherwise identical.

I will mention here two consequences of this analysis. The first is that the Sanskrit-Greek correspondence uncovered provides the basis for a reconstruction of the Indo-European onset structure. This is obviously an enterprise that lies beyond the scope of this study but one may point out here an additional indication that the reconstruction begun here is on the right track : Germanic attests the same contrast in perfect reduplication patterns between true onsets and heterosyllabic initials as Sanskrit and Common Greek. The data, limited to the reduplication facts of Gothic, is scanty but contains

the necessary minimal pairs. Sl , as in slepan 'to sleep', reduplicates like an onset cluster, yielding in the perfect sai-slepun 'they slept' (also spelled saizlepun), exactly as fraisan 'to look for', gretan 'to cry' yield reduplicated perfects fai-frais 'I looked for', gai-grot 'I cried'. S-stop clusters, on the other hand, seem to follow a distinct rule : they reduplicate the entire initial cluster, as if the members of the heterosyllabic initial are monoconsonantal clusters at the time of reduplication : stautan'to hit' , skaidan 'to shear' yield stai-staut, skai-skaiθ. This monoconsonantal behavior of the heterosyllabic initials is in agreement with the fact that Old English prosody allows s-stop initials to alliterate only with each other and not with any other initial s (Bright 1891). The significant fact here is the contrast between sl- and s-stop- initials, pointing to a Germanic inventory of onsets very similar to that of Greek and Sanskrit.

The second consequence concerns the internal history of Greek : if clusters like kt, pt, mn, ml have once been possible onsets in Greek they must have reduplicated in the perfect according to the tautosyllabic pattern (class (a)) . The perfect stems of verbs beginning with kt, pt, mn, ml must have been kekt-, pept-, memn-, meml- , rather than ekt-, ept-, emn-, eml-, the expected Attic pattern. Such reduplicating archaisms are in fact attested. As all morphological archaisms they are found in the core vocabulary and the poetic style. A central item like ktaomai 'to acquire' has both the archaic reduplicated stem attested in ke-ktā-mai (based on the early syllabification cta) and the newer reduplicated



stem e-ktā-mai (based on the heterosyllabic analysis of the initial cluster kt). Two pt- initial roots have once attested pe-pt- reduplications : pe-ptērug-ō-mai (Sappho 32) 'I have flown' and pe-ptuk-tai (Aristotle Hist. Anim. 536^a II) 'has been folded'. In addition, the root ptē(k) 'to frighten' regularly forms in the epic language its perfect active participle as pe-ptē-ōs 'cowering, crouching' : the corresponding Attic perfect stem is e-ptē^h-a or e-ptēk^h-a. All other kt-,pt-,p^ht^h- initial verbs that have attested perfects show only the reduplication pattern based on the heterosyllabic assignment of the initial cluster : e-kton-a 'I killed', e-ktenis-menos 'combed', e-kti-k-a 'I have founded', e-ptai-k-a 'I stumbled', e-pternik-a 'I struck with the heel', e-ptērō-menon 'winged', e-ptis-mai 'I winnowed grain', e-ptu-k-a 'I spat', e-p^ht^ha-k-a 'I overtook', e-p^ht^heg-mai 'I uttered', e-p^ht^har-k-a 'I destroyed', e-p^ht^hi-k-a 'I decayed'.

Similarly, the root mnā 'to remember' has only the archaic perfect me-mnā-mai attested. So also does the root mlō 'to walk (surface blō- as in blō-sk-ō, after the epenthesis of b in the ml cluster and the simplification of the mbl- initial) : its perfect is constantly me-mblō-k-a rather than e-mblō-k-a.

Such forms are clearly exceptional when compared to the productive reduplication patterns of all other verbs that begin with an Attic heterosyllabic initial . But their existence as archaisms is expected given the earlier onset status of the clusters mn, ml, kt, pt <15> . In contrast, the heterosyllabic initials of Attic that must have been heterosyllabic also in earlier times should give rise to no such exceptions to the synchronic Attic reduplication rule : such heterosyllabic initials are the s-stop- , z-stop- sequences , as well as the geminate initials

of roots like sseu 'to rush', perfect e-ssu-mai. <16> .

The continuant -stop clusters are extremely frequent as root initials in Greek : I have counted in Liddell-Scott (1968) 41 verb roots beginning with s-stop sequences and 5 beginning with zd which have attested reduplicated perfects. Among these, the only root which appears to reduplicate according to the class (a) (tautosyllabic) pattern is stā 'to stand', perfect ^he-stā-k-a from se-stā-k-a. This one exception can be attributed to the analogy of the reduplicated present ^hi-stā-mi, the only reduplicated perfect of a continuant-stop initial root. All other 45 roots of this class follow the (b) pattern of perfect reduplication : no archaisms are attested here and none is expected. In all periods of Greek history the continuant-stop initials of these roots failed to qualify as possible onsets.

5.

We have begun this investigation into the structure of heterosyllabic initials by considering three phenomena which take place in syllable initial position : the reduplication of a first consonant in the initial syllable of a verbal root; the spelling of a syllable initial cluster in the Linear B script; the syllable initial change of s and y to h in Common Greek. The first member of a heterosyllabic initial is systematically off-limits for these processes, a fact predicted by the stray C analysis of such clusters. None of the facts encountered so far required the introduction of more complex structural differences between onset clusters and heterosyllabic initials than the difference between

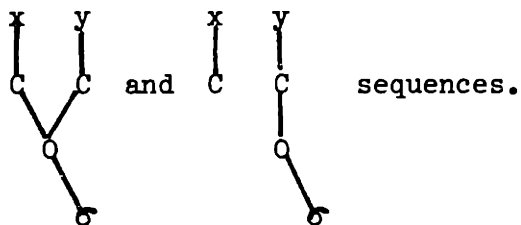

In fact, we have seen that assigning more complex structures to the heterosyllabic initials will require complicating the analysis of Greek and Sanskrit reduplication and that of the Linear B spelling system.

We consider now a different set of facts that support the stray C hypothesis. These center around a principle of Greek prosody we have already had occasion to invoke, in (7), chapter 3 :

(56) A metrical line is syllabified without regard to word and phrase boundaries, as if it consisted of a single word.

(56) is a pretheoretical account of the fact that postvocalic heterosyllabic initials, as in para gnōmēn 'contrary to expectation', ta skeuē 'the utensils', always close a preceding syllable (pa.rag.nō.mēn, tas.keu.ē) thus creating across compound or phrasal boundaries the same type of syllable structures that are encountered within a single word or compound member. As principle (56) is, in slightly modified form, valid in Latin also, my discussion will refer to the prosodies of both classical languages. The argument, in its barest form, is as follows : the rule which produces pa.rag.nō.mēn is no re-assignment of syllable structure but rather a regular application of the coda rule. The stray member of a heterosyllabic initial will be available for assignment to the coda position of a preceding syllable and will undergo the coda rule whenever that rule will be met. In contrast, the first member of a

branching onset like gr, in phrases like anti grap^hēn 'against the indictment' compounds like anti-grap^hē 'plea', is not resyllabified as a coda.

This follows from the fact that it already holds a syllabic position : syllabification rules, we saw in Chapter 1, section (3.2.3), do not change already assigned syllable structures. The following sections will develop this explanation for principle (56) and will show that it is available only within the stray C format.

6. Syllabification across major boundaries

The following correlation is observed between the morpheme internal syllabification of VCCV sequences and that of V][CCV sequences, where the brackets indicate a major, compound or phrasal, boundary:

(57) The consonant clusters which must be heterosyllabic within a single morpheme in a VCCV sequence are also the clusters which are heterosyllabic when separated by any boundary, including a compound or phrasal boundary, from a preceding vowel.

(57) holds for all V][CCV sequences of Greek and for all word internal heteromorphemic sequences of Latin. Thus, according to Devine and Stephens (1977 : 132) , Kühner-Holzweissig (1966 : 228) and Hoenigswald (1949) the heterosyllabic assignment of an initial CC cluster is permitted in the native Latin prosody only across a compound or prefix boundary, not across a word boundary. The infrequent exceptions to this rule that one finds in the post-Plautinian prosody

(type nulla spēs 'no hope' scanned nul.las.pēs in Catullus 64, 186) are attributed by Hoenigswald to the influence of the Greek prosody.

Thus Latin syllabifies [re[spersi]] 'I sprinkled' and [[haru][spēx]] 'soothsayer' as res.per.sī, ha.rus.pēx but allows the final syllable of pōnite in pōnite spēs 'abandon hopes' (Vergil Aeneis 11.309) to stay open and therefore light. In contrast, the heterosyllabic initials of each period or poetic style of Greek close a preceding syllable across any boundary, including a word boundary : ta skeuē is scanned tas.keu.ē (Aristophanes, Wasps 939), epi splank^hna 'after the innards' is scanned e.pis.plan.k^hna (Aristophanes, Peace 1040), katep^ht^here straton 'destroyed the army' is scanned ka.tep^h.t^hē.res.tra.ton (Aeschylus , Persians 345).

The correlation in (57) is not a trivial consequence of the late, postcyclic or phrasal, character of syllabification. For Greek, the cyclic nature of syllabification has already been established in Chapter 3. That syllabification is cyclic in Latin too is indicated by several disparities between the morpheme internal and the across-morpheme assignment of consonant clusters. One such fact is the heterosyllabic assignment of V stop][liquid V sequences : verbs like ab-rogō 'I annul', ob-ligō 'I fasten' are always scanned ab.ro.gō, ob.li.gō, never *a.bro.gō, *o.bli.gō , a fact we already made use of in Chapter 3, section 5.6. Had syllabification been postcyclic in Latin, no distinction could be maintained between the stop-liquid sequence in these forms and a tautomorphic stop-liquid sequence like that of te.ne.brae. Another indication of the cyclic nature of Latin syllabification is the distribution of i and y in postconsonantal position : morpheme inter-

nally after a consonant, i must be syllabic, whether a vowel follows or not, as in mulier (*mulyer). However, at the beginning of a compound member or word any prevocalic i must be non-syllabic, whether or not a consonant precedes : iungo and con-iungo are treated identically in this respect since both contain

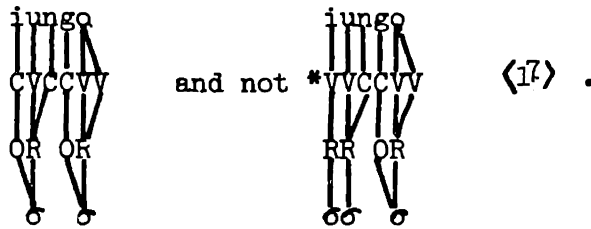

Again, if syllabification is not cyclic, the distribution between post-consonantal non-syllabic i in con-iungō (con.yun.gō) and postconsonantal syllabic i in mulier (mu.li.er) cannot be accounted for. On the hypothesis that syllabification is cyclic all the facts follow : i in iungō is assigned onset-status before the prefix final consonant is encountered, on the cycle preceding prefixation of con.

Thus principle (56) as stated is partly incorrect : it is not the case that all boundaries are disregarded in syllabifying a metrical line or a phrase in the spoken language. Syllabification proceeds cyclically in both cases, yet the across-boundary syllabification of V][CCV sequences closely parallels that of tautomorphic VCCV sequences, as if the boundaries were ignored only in the V][CCV case.

The solution to this apparent paradox follows from the stray C analysis of heterosyllabic initials : the coda rule is applicable to any VCCV sequence that contains a first stray C, including to a V][CCV sequence containing a heterosyllabic initial.

The coda rule is not applicable to any VCCV sequence in which both C's have already been assigned to the onset of the next syllable : this also includes the case of V][CCV sequences containing branching onsets. Thus the partial correlation between morpheme internal and across-boundary assignment of consonant sequences, as stated in (57), follows from two already necessary principles : (a) core syllabification rules apply only to stray consonants; (b) the onset rule precedes the coda rule.

The alternatives to the stray C analysis considered above share the property of assigning to each member of a heterosyllabic initial a syllabic position : that of a premargin node in the onset, that of an appendix or of a degenerate syllable. On the face of it they seem incapable of deriving the facts abbreviated by (57) without additional stipulation.

But all analyses will have to state the fact that heterosyllabic initials are permitted only at the edges of syllabification domains. The facts recorded in (57) may seem to follow from this limited distribution of heterosyllabic initials : if so, any analysis that acknowledges the restriction on where heterosyllabic initials may surface will be able to account for their assignment across major boundaries.

A concrete proposal along these lines will go as follows : constituents like the premargin, the appendix, the degenerate syllable are allowed only at the beginning of a cycle. When on a later cycle such a node turns out to be no longer in a peripheral position , the node is erased by the following convention :

(58) Erase a premargin/appendix/degenerate syllable unless it is leftmost in its domain.

Convention (58) will create the required stray segments at the beginning of a heterosyllabic initial in (59) below . I illustrate only the effect of convention (58) on heterosyllabic initials analyzed as appendix - onset sequences. The label W under a left bracket indicates a word boundary .

(59) a. [dia_W[p^ht^herē]] [straton] 'destroys the army'

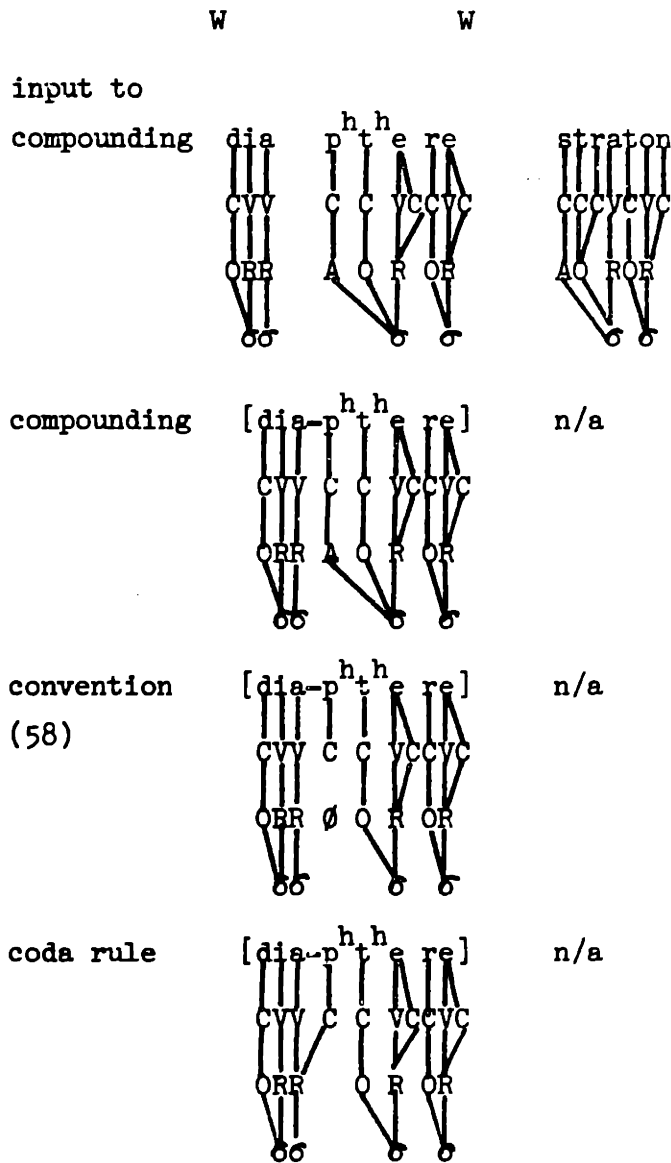

(59) continued

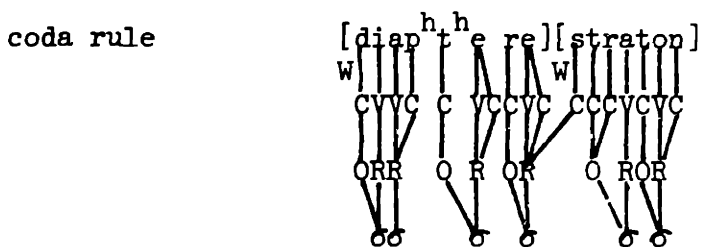
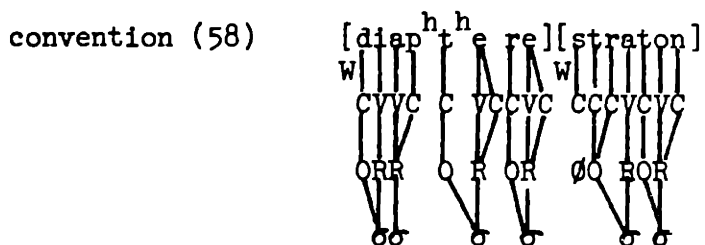
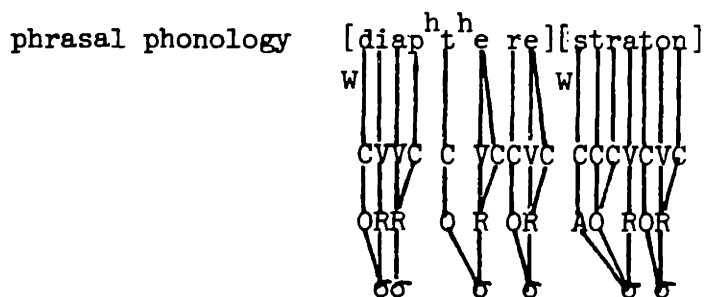

Thus it seems that the resyllabification facts do not choose between alternative analyses of heterosyllabic initials. This would be the case if the central assumption on which convention (58) is based could be upheld - namely that heterosyllabic initials surface either at the beginning of a syllabification domain or as coda-onset sequences, as in res.per.sī or di.ap^h.t^he.rēs.tra.ton, but nowhere else.

This assumption however is false. Some heterosyllabic initials surface in both Latin and Greek both phrase and word medially after consonants as well as after vowels. We will review such clusters in the next section. One cannot therefore attribute the obligatory heterosyllabic assignment of postvocalic heterosyllabic initials to a convention like (58). If so, we must return to our original conclusion that the facts concerning syllabification across major boundaries

of V][CCV sequences are accounted for only under the stray C hypothesis.

7. Clusters across major boundaries, adjunction rules and
the Stray Erasure Convention

Heterosyllabic initials occur in both Greek and Latin at the beginning of major constituents - compound members or words - regardless of whether a segment, vowel or consonant, precedes them. (60) and (61) below illustrate only postconsonantal heterosyllabic initials attested word internally in Greek and Latin :

(60) Greek postconsonantal heterosyllabic initials

- a./sun/ sun-gnōmē 'forgiveness'
sum-mnēmoneuō 'to remember at the same time'
- b./pant/ pan-ktēsiā 'full ownership'
pam-bdeluros 'utterly abominable'
- c./eks/ ek-strateuō 'to march out'
ek-stasis 'displacement'
ek-ptōsis 'falling off'
ek-ktupeō 'to burst forth with noise'

(61) Latin postconsonantal heterosyllabic initials

- a./ab(s)/ ab-stō 'to stand at a distance'
- b./ek(s)/ ex-spectō 'to look out for'
ex-stinguō 'to put out'
ex-struō 'to pile up'
- c./ob(s)/ ob-stō 'to stand against'
ob-stringō 'to bind up'

I have selected for both languages examples of consonant clusters arising across a compound boundary which could not surface inside the same compound member. Contrast for example /sun-gn̄m̄ē/ and /p^ht^heng-mat/ both of which include the sequence nasal-voiced stop-nasal : the latter surfaces , after place assimilation and Stray Erasure, as p^ht^henma, with its medial stray stop eliminated. The former undergoes place assimilation but maintains intact its heterosyllabic initial. Examples like this establish that heterosyllabic initials are allowed to surface even when they cannot undergo the coda rule.

The final consonant deletion illustrated by (60.b-c) (/pant-bdeluros/ => pam-bdeluros) is specific to Greek and covers all extrametrical consonants followed across a boundary by another consonant. The following consonant doesn't have to belong itself to a heterosyllabic initial, as examples like h^hek-kai-deka 'sixteen' (from h^heks 'six', kai 'and', deka 'ten') indicate.

What allows heterosyllabic initials to surface when their first member has not been assigned a coda position ?

This question must be answered differently for Greek and Latin. In Latin two processes of word-level syllabic adjunction, stated in (62) below, provide for the syllabic incorporation of preconsonantal continuant obstruents.

(62) Latin Stray Adjunction

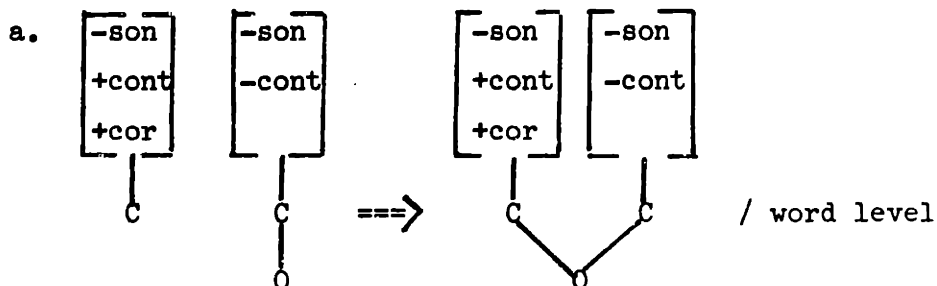

(62) continued

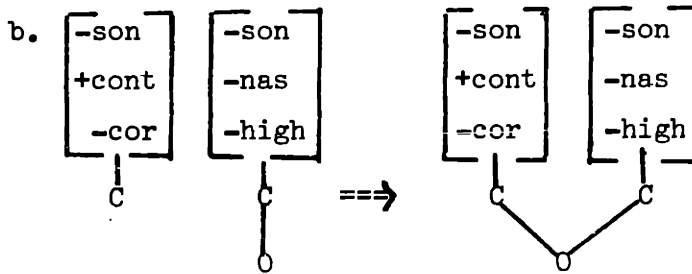

(62) states that a stray continuant obstruent is attached to a following onset; moreover, the attached consonant must be coronal (s) if the following syllable begins with a stop, noncoronal (f) if it begins with a liquid. The rules in (62) effectively define the set of surface heterosyllabic initials of Latin : s -stop-(liquid) clusters and f-liquid clusters. Since the attachment of no other stray consonants is provided for no other heterosyllabic initials will surface either phrase initially or after a consonant.

This aspect of the analysis is relatively difficult to verify as there are few underlying Latin clusters in initial position which do not fit either the description of the onset rule (as defined in Chapter 1, section (3.4.)) or that of the Stray Adjunction rules in (62). One may mention two native Latin clusters: tl- in /tlā-to-m/, suppletive perfect participle of ferō 'to bear', which assimilates to llatum and is then simplified to lātum, since neither the onset rule nor (62) can incorporate a geminate sequence; and gn- in the roots gnā of /gnā-sk-ō-r/ 'I am born' and gnō of /gnō-sk-ō/ 'I learn'. The initial g of the last two forms is lost everywhere except after a prefixal vowel, that is in the environment where the stray member of a heterosyllabic initial can become a coda : we obtain in this way the alternations between nascōr and co-gnātus (cog.nā.tus) 'blood relative', nōscō and co-gnōscō (cog.nos.cō) 'to learn' (18).

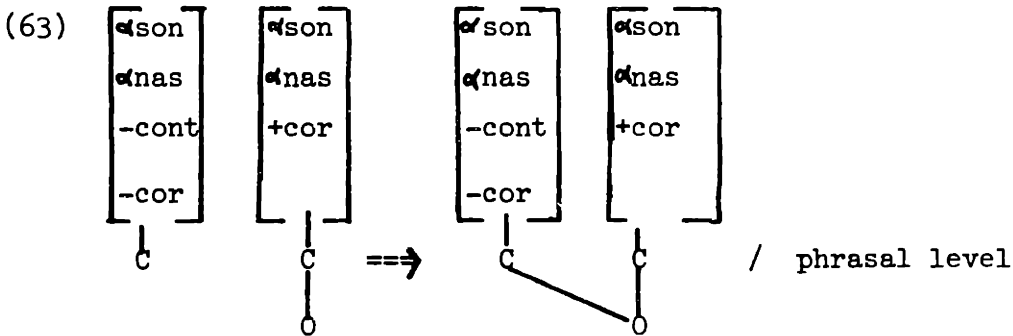

(63) will incorporate the stray member of the initial clusters pt, p^ht^h, kt, k^ht^h, p^hs, k^hs, and mn. The remaining heterosyllabic initials will be accounted for by rules (64) and (65) :

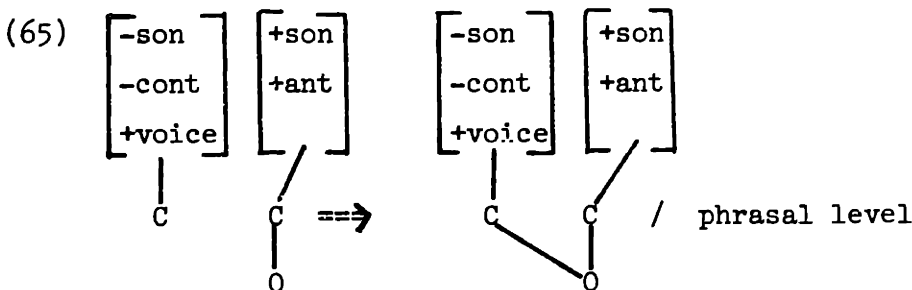
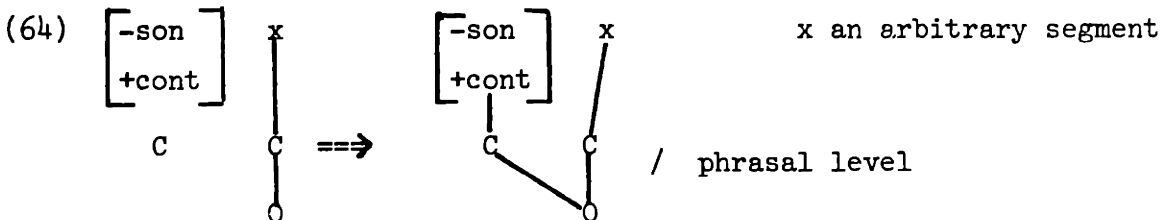

Are there underlying initial clusters in Grek which fail to undergo both the onset rule and one of the Stray Adjunction rules above ? I know of one such case in Attic and of several in the epic language.

Beginning with the latter class, the root mro 'to die' undergoes the epenthesis of a stop homorganic to the nasal and thus becomes intermediate mbro-, as in -mbrotos 'mortal'. Word initially the cluster is simplified to br-, hence brotos. We cannot tell whether the full mbr- heterosyllabic initial is maintained when the word is preceded

by a vowel , because the atticized version of the homeric text transmitted to us could have substituted the restructured form brotos inherited by Attic to an original epic mbrotos without altering the meter : both clusters, mbr as well as br are heterosyllabic in the homeric prosody. M in mbrotos is clearly maintained when occurring as a second member of a compound : a-mbrotos 'immortal', p^hilo-mbrotos 'loving mortals', terp^hsi-mbrotos 'enchanting mortals', olesi-mbrotos 'destroying mortals', damasi-mbrotos 'taming mortals', t^helk^hsi-mbrotos 'charming mortals', akesi-mbrotos 'healing mortals' are only a small selection of the -mbrotos compounds. Not all are attested in Homer but all belong to the poetic language whose roots are in the epic dialect <20> .

The heterosyllabic initial of mlō 'to walk', mblō after epenthesis is maintained only in the reduplicated perfect me-mblō-k-a. An isolated case in which a mbl- root initial surfaces after a prefixal vowel is that of kata-mblakeuō 'to treat carelessly, to mismanage', on the root of blāk^hs 'stupid'. The Attic equivalent is kata-blakeuō.

The initial cluster of sseu 'to rush' , on the other hand, is fully attested in the entire class of environments where the initial s could be syllabified as a coda : after the augment and the reduplicating syllable (e-sseu-a, e-ssu-mai), after a vowel final prefix (epi-sseuō in e 421 and O 347) and after a vowel final word, where, according to Magnien (1920), sseuō regularly closes a preceding syllable.

The language of the Attic tragedy and later Nonnos have preserved compound adjectives like h^omo-ssutos 'rushing together', apo-ssutos 'rushing away', h^etero-ssutos 'darting from the other side', auto-ssutos 'self-spied'.

One might also suggest that the alternation between word initial dōpos 'thud' , dōpeō 'to make a heavy sound' and postvocalic e-gdōpēsa (L 45), eri-gdōpos 'thundering', meli-gdōpos 'sweet sounding', baru-gdōpos 'loud sounding' reveals another underlying heterosyllabic initial which fails, in Homer's language at least, to undergo one of the rules of Stray Adjunction. There are no surface heterosyllabic initials like gd, bd in the epic language other than postvocalic -gdōpos (words like Attic bdeluros do not occur) so we might hypothesize that the epic language restricts rule (66) to voiceless stops:

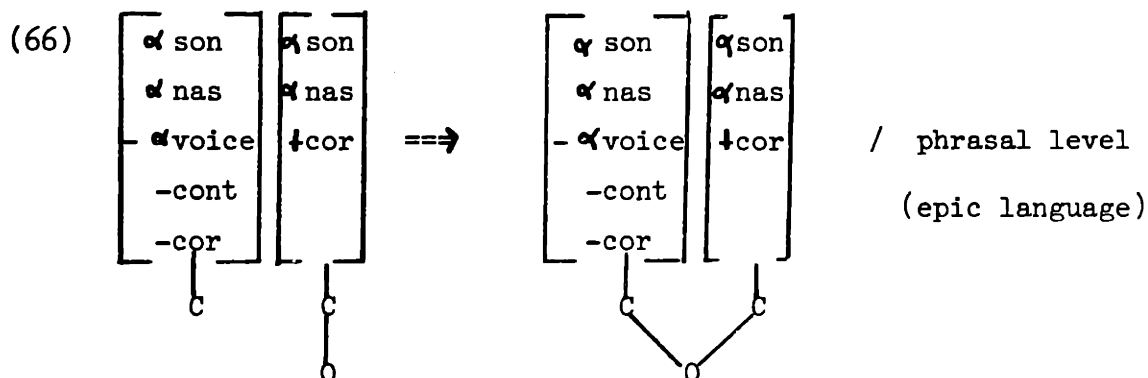

The adjunction rule above will not apply to either bd or gd thus accounting for the absence of initial gd in environments where its first member cannot become a coda. The gd- initial of the epic language will then be in exactly the same class as the mbr-, ss- initials.

Attic has, on one hand, restructured the mbr, mbl, ss and gd heterosyllabic initials of the epic language to br, bl, s, d onsets. It has however innovated also in the opposite sense by generalizing the biconsonantal behavior of certain initial r's (historically sr, wr initials) to all initial r's : from the synchronic point of view all Attic words , compound members or roots beginning with r have in fact

a geminate initial. This generalization points to the following rule :

(67) Attic r-Gemination

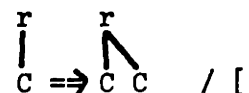

Attic r-Gemination will insert a second C at the initial of any cyclic constituent beginning with r, thus creating clusters that will meet neither the Attic onset rule nor any of the Stray Adjunction rules in (63)-(65). The heterosyllabic initials generated by (67) surface, as predicted, only in the following environments : (a) after the augment or the reduplicating syllable : aorist e-rreu-s-a and perfect e-rru-ē-k-a of the root reu 'to flow'; (b) after a vowel final prefix or first compound member : epi-rrutos 'running, flowing', epi-rrōnnūmi 'to strengthen', mono-rrut^hmos 'of a solitary kind' ; (c) after a vowel final word in the phrase, as evidenced by the scansion of lines such as :

$$\begin{array}{ccccccc} \text{h} & \text{v} & \text{v} & \text{v} & \text{h} & \text{v} & \text{h} \\ \text{ōs} & \text{ōk} & \text{agat} & \text{on} & \text{esti} & \text{to} & \text{rop} & \text{ēn} \\ \text{h} & \text{v} & \text{h} & \text{v} & \text{h} & \text{v} & \text{h} & \text{v} \\ \text{ō} & \text{sō} & \text{ka} & \text{ga} & \text{t} & \text{o} & \text{nes} & \text{ti} & \text{tor} & \text{ro} & \text{p} & \text{ēn} \end{array}$$

'Oh how bad it is to gulp down !'

(Aristophanes Wasps 982)

The Stray Adjunction rules posited so far answer only in part the original question : what allows the stray member of a heterosyllabic initial to surface ? We have explained why Stray Erasure does not affect certain heterosyllabic initials at the phrasal level. We know

however that Stray Erasure must also apply within the lexical component in order to eliminate the medial stray consonants of /CV-grap^h-st^hai/, /p^ht^heng-mat/ and similar examples. If we allow the stray C's in such forms to reach the postcyclic stage of the derivation then one of the Stray Adjunction rules will apply to them, yielding

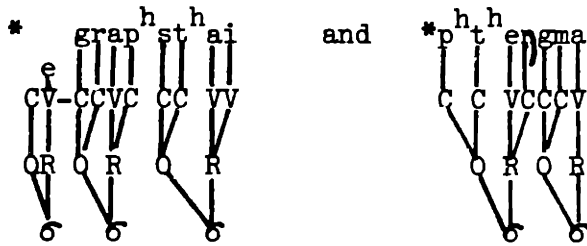

rather than the expected gegrap^ht^hai, p^ht^hengma. No explanation will then be available to the fact that the medial consonant in such clusters is lost. For this reason we need an application of Stray Erasure before the phrasal Stray Adjunction rules become applicable. If so, the stray consonants at the beginning and end of a word or compound member must be explicitly exempted from the application of Stray Erasure.

We can accomplish this by introducing an extrametrical position at the beginning and end of each compound member. Using Liberman and Prince's terminology (1977), I will identify a compound member as Mot, abbreviated as M, keeping Word, abbreviated W, for the superordinate lexical unit. The required extrametrical positions are stated below as first and last unit in the compound member (M) template :

(68) M template

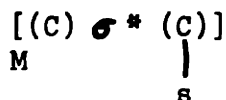

A compound member consists of a sequence of syllables optionally preceded by a consonant and optionally followed by s . Since the initial C and the final s are positions sanctioned by a morphological template like (68) they cannot be affected by Stray Erasure, at least not as long as the constituent M is intact. Only after the Bracket Erasure Convention applies to the compounding level are the syllabically unattached consonants at the beginning and end of the M constituent subject to Stray Erasure. Consider for example a complex compound like sun-dia-batos 'which can be crossed together', whose full underlying structure is

[[[sun] [[dia] [ba-to-s]]]]
 W M M M M M

There are two compounding rules : the prefixation of dia , yielding

[[dia] [batos]]
 M M M

and that of sun, whose result is

[[sun] [[dia] [batos]]] .
 W M M M M

At the end of the compounding level , the last level in the lexical component of Greek, and after the application of Stray Erasure, internal brackets are erased and we obtain

[sundiabatos] .
 W

No M constituent is thus identifiable inside sundiabatos in the input to the phrasal component.

A compound like sun-gnōmē, which includes a postconsonantal heterosyllabic initial, will go through the following stages :

(69)	[sun]	[gnōmē]
	M	M
compounding	[[sun][gnōmē]]	
	WM	M
Stray Erasure	n/a	
Bracket Erasure	[sungnōmē]	
	W	
phrasal phonology		
rule (65)	[sunɡno me] ==> [sunɡno me]	
Stray Erasure	n/a	

The Stray Erasure convention is never applicable to such a case : at the word level g is still part of the M-template when Stray Erasure applies; at the phrasal level, the Stray Adjunction rule (65) preempts the last application of Stray Erasure. In a case like /p^ht^heng-mat/ Stray Erasure is applicable at the word level : neither the stray g nor the stray final t are in the M-template. Finally, in a case like mbrotos, Stray Erasure is not met at the word level, when m is still part of the M-template, but it does apply at the phrasal level, after the Stray ADjunction rules have failed to attach m to any syllable.

I have already explained in chapter 3, section 5.4. , why we need to specify that the final extrametrical consonant in the M template

must be s in Greek. We need to add now that , if still stray, s is adjoined to a preceding syllable at the phrase level. Rule (64) above can in fact be extended to apply in mirror image fashion to both final and initial stray s's : neither adjunction poses any condition on what the adjacent segment of the syllable incorporating it should be. I therefore replace (64) with (70) :

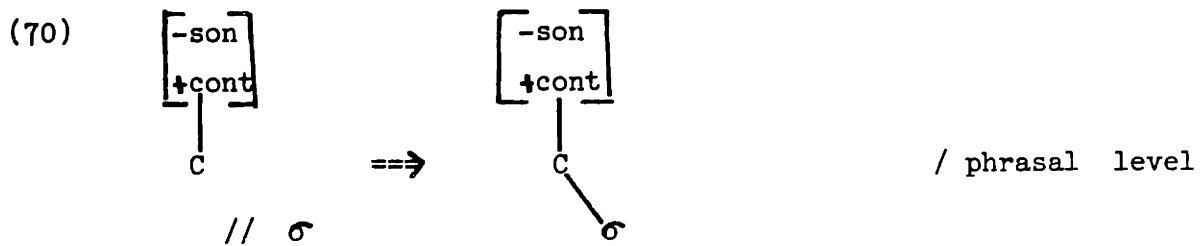

(70) states that a stray C dominating a continuant obstruent is incorporated into a neighboring - preceding or following- syllable.

Given our discussion of heterosyllabic initials in Common Greek and Indo-European , we may mention the possibility that a rule as general as (70) was the only Stray Adjunction rule necessary in earlier times, when clusters like pt, gn, sm, mn were possible onsets rather than heterosyllabic initials. Thus the real complexity in the Attic system of Stray Adjunction rules comes from the need to incorporate the inventory of clusters inherited from Common Greek, after the core syllabification rules had changed.

Chapter 4 : Footnotes

1. On this notion see Fudge 1976, Steriade 1979, Selkirk 1981, Lowenstamm 1982.

2. The notion of appendix was introduced independently by Halle and Vergnaud (1981) and Fujimura and Lovins (1978) : in the latter work it bears the name syllable affix in contrast to syllable core and is explicitly allowed both after and before the syllable core. Halle and Vergnaud consider only word final appendices. In both works, the appendix is introduced to characterize word final and word initial sequences that exceed the possibilities of syllabic nodes like rime and onset. The German appendix, as discussed by Halle and Vergnaud, is allowed not only at the beginning and end of words but also at the edges of cyclic constituents. Neither Fujimura and Lovins nor Halle and Vergnaud address the possibility that the sequences in question might in fact be stray consonants during at least the cyclic stages of the phonological derivation. The facts they present seem compatible with a stray C approach. The analysis of Malayalam syllable structure offered in Mohanan 1982 relies heavily on the notational possibilities made available by the introduction of the appendix. For example, Mohanan characterizes a postlexical process of r-depalatalization as occurring in the appendix (cf. section 4.1.5. of the work cited). I hope however to show in forthcoming work that an alternative analysis of Malayalam syllable structure can be motivated on the basis of the evidence presented by Mohanan : such a reanalysis will make recourse to the label Appendix

unnecessary and will eliminate a number of descriptive and conceptual difficulties inherent in Mohanan's approach.

3. This form is not encountered in the texts but is prescribed by the grammarians. The data is from Whitney 1885. The transliteration is that used by Whitney except in the case of the palatal continuant ṣ transliterated by Whitney as ç. The palatal : velar alternation attested in forms like ca-kṣame and the aspirated : nonaspirated alternation in ta-st^hau will be ignored here as irrelevant. The s : ṣ alternation of smi- : si-smi- is due to the operation of the ruki rule : see Whitney 1889 : paragraph 180, 188, Kiparsky 1982 for the analysis.

4. Examples like porp^hura suggest that in Greek the V of the reduplication unit is specified as [-high]. For the lack of aspiration in the reduplication syllable , see chapter 3, 5.5.2.3.

5. Curtius (1883 : 357) also cites koskulmatia 'cuttings of leather', a reduplicated diminutive on skulma 'hair plucked out'. The semantic connection is not entirely clear , however, and the loss of l - one would expect kol-skulmatia -unexplained . For the difference in vowel height between the root vowel u and the reduplication o see footnote 4.

6. Some clusters allowed by the conjunction of (36) and (37) do not actually occur as onsets in Sanskrit : pt, kt, gd, bd, nw, lw. I do not know that they have underlying sources as root or word initials in this language. Almost each of the complex onset clusters predicted

but unattested in Sanskrit will show up as tautosyllabic in Mycenaean, a language that, we will see, has inherited from Indo-European the same sonority scale and the same MSD requirement as Sanskrit.

7. A-rud-d^ha results from the application of Bartholomae's Law on the intermediate cluster d^ht, left after the loss of the unsyllabified s.

8. The Linear B inventory of signs also lacks the means to distinguish voiced from voiceless non-coronal stops, aspirated from non-aspirated consonants, r from l.

9. Lejeune (1972 : 285) considers an account of the Mycenaean spelling conventions essentially identical to (40). However, on noting what this account tells one about the syllabic assignment of Mycenaean clusters like sm, sw, mn, nw ("la structure des syllabes (avec une nette prépondérance du type ouvert) serait profondément différente de ce qu'elle est au premier millénaire") Lejeune decides to remain sceptical about a phonological interpretation of the spelling facts : "Aussi doit-on faire des réserves sur l'interprétation phonétique d'une orthographe peut-être héritée (...) d'une tradition graphique préhellénique."

10. Pte is one of the few signs that represent a CCV syllable. Others are nwo, dwe, rjo, rja.

11. See Chapter 3, section 5.5.5. for the justification of transliterating wi-ri-za as wrizza rather than wrizda.

12. The spelling po-ni-ki-pi interpreted as p^hoinik-p^hi 'with phoenixes' does not indicate an assignment p^hoi.ni.kp^hi (which would be contradicted by pu-ra-pi, p^hu.lak.p^hi) but rather the option, rarely exploited, of spelling out the coda of a syllable by copying after it the nuclear vowel. This infrequent practice is attested in spellings like wa-na-ka, wa.naks 'lord'; wo-ro-ki-jo-ne-jo, wor.gi.yo.ne.yos 'belonging to a college of priests'.

13. Lejeune (1972 : 124 ff.) notes a number of lexical exceptions to the rule, when s is preceded by a liquid. Among them are Dative plurals like t^hēr-si 'beasts', futures like or-s-ōs-a 'who will arise-FEM', first member of compounds like a-kerse-komēs 'with unshorn hair' (root ker 'to shear').

14. It was suggested to me by John Ohala that the change would be more natural if broken up in to steps : y becomes a coronal obstruent in syllable initial position (as it plainly must in cases like zdugon, from Indo-European *yugom 'yoke') voiced or voiceless (s) depending on the lexical item. Then s, whether underlying or derived, becomes h by rule (51) which will therefore affect also some underlying y's, turned into s's. Unfortunately, the chronology of the y => h, s => h changes appears to be the reverse of what this hypothesis would predict. In Mycenaean s is already h, either not spelled or spelled a₂ for h_a, but y is still preserved in some cases such as jo-, the relative pronoun. Most significantly, we never find an expected

jo- spelled so-, although we find the jo- : o- variation predicted by a direct, but still optional, $y \Rightarrow h$ rule.

15. One may add to this list the epic perfect h_{-} emartai (root smar 'to allot') with its formulaic meaning 'it was decreed by fate' : h_{-} emartai results regularly from /CV-smar-tai/ reduplicated se-smart-tai , through the intermediate stages h_{-} mar-tai, h_{-} emartai after the loss with CL of the middle h. The initial aspiration is maintained as in h_{i} -stā-mi from si-stā-mi. h_{-} emartai is not to be derived from a class (b) reduplicated form e-smar-tai \Rightarrow $ē$ - h_{-} mar-tai \Rightarrow h_{-} emartai, through the reassociation of the autosegmentalized h , because no other reduplicated perfect of s-sonorant- roots yields surface aspirated initials : lambanō (slab 'to grasp'), legō (sleg 'to pick up'), lank^hanō (slak^h 'to obtain by lot') have perfects with unaspirated initial vowels such as ēlāmmai (from e-slāb-mai), ēlēgmai (from e-slēg-mai), ēlāk^ha (from e-slāk^h-a). Had h_{-} emartai been the result of underlying e-smar-tai we would also expect * h_{-} elammai, * h_{-} elēgmai, * h_{-} elāk^ha. Thus the best account of the reduplication types among roots which begin with an s-sonorant cluster is to assume that the majority reduplicated as heterosyllabic initial roots, in accordance with the 1st millenium syllabification of s-sonorant clusters (syllabification indirectly attested by the CL effects in ēlāmmai, etc. : es.lām.mai \Rightarrow ē.lam.mai). The root initial s was then deleted rather than turned to h , by the s-deletion rule motivated in chapter 2 (rule (32)). The results were unaspirated initials and CL . h_{-} emartai remains apart as an archaism, comparable to ke-ktāmai, me-mblōka, pe-ptēōs : the initial s-sonorant cluster was syllabified as a heterosyllabic initial, hence the CL accompanying the loss of s, but the reduplication

continued to be that of a tautosyllabic initial : se-smar-tai.

16. Most geminate initials are of very recent origin within Attic and would therefore not be expected to provide archaisms. They include for example the r initial clusters created in Attic by a rule



discussed in section 7. These geminate initials invariably reduplicate as heterosyllabic initials, as predicted : reu 'to flow' yields e-rruē-ka, rēg 'to break' yields e-rrēg-mai, rōs 'to strengthen' yields e-rrō-mai.

17. A Vergilian line (Aeneis 8,555) exemplifies both treatments of postconsonantal i :

$\text{— } \cup \cup / \text{— } \cup \cup / \text{— } \text{—} / \text{— } \cup \cup / \text{— } \cup \cup / \text{— } \text{—}$
 Tālia coniugia et tālis celebrent hymenaeos

(tā.li.a con.yu.gi.et.tā.lis. ce.le.bren.ty.me.nae.os)

'that they celebrate such links and such nuptials'

18. Gn is sometimes spelled out, as in gnātus, in what appear to be morphophonemic or archaic spellings. Zirin (1970) notes however that the orthographic g of such clusters always fails to make position in the verse, in contrast to the s-stop clusters which are sometimes permitted to close the final syllable of a preceding word, in imitation of the Greek prosodic practice.

19. We must provide for the case when sequences like gl, bl are heterosyllabic, in case they fail to undergo the onset rule.

20. On the homeric epithet am^hi-brotē (aspis) 'covering the whole man' (of a shield) see Lejeune (1972 : 307) : not only is the m missing but br is exceptionally scanned as if tautosyllabic - an exceptional assignment in Homer - obviously in order to avoid the unmetrical sequence "~~" .

Bibliography

- Abu-Haidar, F. (1979) A Study of the Spoken Arabic of Baskinta, E. Brill, Leiden and London.
- Allen, W.S. (1968) Vox Graeca, Cambridge University Press, Cambridge, England.
- _____, (1973) Accent and Rhythm, Cambridge University Press, Cambridge, England.
- Bell, A. and Hooper, J.B., ed. (1978) Syllables and Segments, North Holland, Amsterdam.
- Borer, H. and Aoun, Y., ed. (1981) Theoretical Issues in the Grammars of Semitic Languages, MIT Working Papers in Linguistics, Vol. 3, MIT, Cambridge, MA.
- Buck, C.D. (1973) The Greek Dialects, University of Chicago Press, Chicago, IL.
- Cairns, C.E. and Feinstein, M.H. (1982) "Markedness and the Theory of Syllable Structure," Linguistic Inquiry 13.2, pp. 193-226.
- * Chantraine, P. (1942) Grammaire Homérique: Phonétique et Morphologie, Klincksieck, Paris.
- Chierchia, G. (1981) "An Autosegmental Approach to Raddoppiamento," NELS 12, University of Massachusetts/ Amherst, Amherst, MA.
- Chomsky, N. and Halle, M. (1968) The Sound Pattern of English, Harper and Row, New York, NY.
- Clements, G.N. (1977) "The Autosegmental Treatment of Vowel Harmony" in W.V. Dressler and O.E. Pfeiffer, ed., Phonologica 1976, Innsbruck.
- _____, (1978) "Syllable and Mora in Luganda," unpublished ms., Harvard University, Cambridge, MA.
- _____, (1980) "Vowel Harmony in Non-Linear Generative Phonology: an Autosegmental Model," Indiana University Linguistic Club, Bloomington, IN.
- _____, (1982) "Compensatory Lengthening and Consonant Gemination in Luganda," paper read at the Compensatory Lengthening Minifestival, Harvard University, May 1982, Cambridge, MA.
- _____, and Keyser, S.J. (1980) "The Hierarchical Nature of the Klamath Syllable," unpublished ms., MIT and Harvard University, Cambridge, MA.

- Clements, G.N. and Keyser, S.J. (1981) "A Three-Tiered Theory of the Syllable," Occasional Paper no. 19, Center for Cognitive Science, MIT, Cambridge, MA.
- de Chene, B. and Anderson, S. (1979) "Compensatory Lengthening," Language 55.3, pp. 505-535.
- Curtius, G. (1883) The Greek Verb, John Murray, London.
- Devine, A.M. and Stephens, L.D. (1977) Two Studies in Latin Phonology, Anna Libri, Ann Arbor, MI.
- Feinstein, M.H. (1979) "Prenasalization and Syllable Structure," Linguistic Inquiry 10.2, pp. 245-278.
- Emeneau, M. (1955) A Grammar of Kolami, University of California Publications in Linguistics, University of California Press, Berkeley and Los Angeles, CA.
- Fudge, E. (1976) "Phonotactics and the Syllable" in A. Juillard, ed., Linguistic Studies Offered to Joseph Greenberg II, Phonology, Anna Libri, Ann Arbor, MI.
- Fujimura, O. and Lovins, J. (1978) "Syllables as Concatenative Phonetic Units" in Bell and Hooper (1978).
- Goebel, K. (1876) De Correptione Attica, Typis H. L. Keyser, Argentorati.
- Goldsmith, J.A. (1976) Autosegmental Phonology, Doctoral dissertation, MIT, Cambridge, MA; also New York: Garland Press, 1979.
- Guerssel, M. (1978) "A Condition on Assimilation Rules," Linguistic Analysis 4.3, pp. 225-254.
- Halle, M. and Vergnaud, J.-R. (1980) "Three-Dimensional Phonology," Journal of Linguistic Research, 4.1, pp. 83-105.
- _____, (1982 in preparation) "Metrical Structures in Phonology," unpublished ms., MIT, Cambridge, MA.
- Harris, J. (1982 to appear) Syllable Structure and Stress in Spanish: A Nonlinear Analysis, MIT Press, Cambridge, MA.
- Hayes, B. (1982) "Extrametricity and English Stress," Linguistic Inquiry 13.2, pp. 227-276.
- Hermann, E. (1923) Silbenbildung im Griechischen und in andern indogermanischen Sprachen, Vandenhoeck and Ruprecht, Göttingen.
- Hoenigswald, H. (1949) "A Note on Latin Prosody: s-impure after Short Vowel," Transactions of the American Philological Association, vol. 80, pp. 271-280.

- Hooper, J.B. (1972) "The Syllable in Phonological Theory," Language 48, pp. 525-540.
- Hyman, L.M. (1982) "The Representation of Length in Gokana," Proceedings of the First West Coast Conference in Formal Linguistics, Stanford University, Palo Alto, CA.
- Ingria, B. (1980) "Compensatory Lengthening as a Metrical Phenomenon," Linguistic Inquiry 11.3, pp. 465-496.
- Kahn, D. (1976) Syllable-based Generalizations in English Phonology, Doctoral dissertation, MIT, Cambridge, MA; available from Indiana University Linguistic Club, Bloomington, IN.
- Kaye, J. and Lowenstamm, J. (1981) "De la Syllabicit ," unpublished ms., Universit  du Qu bec   Montr al and University of Texas/Austin.
- Kenstowicz, M. (1982) "Gemination and Spirantization in Tigrinya," Studies in the Linguistic Sciences, vol. 12, no. 1.
- _____, and Pyle, C. (1973) "On the Phonological Integrity of Geminate Clusters" in M. Kenstowicz and C. Kisseberth, Issues in Phonological Theory, Mouton, The Hague.
- Keyser, S.J. and Kiparsky, P. (1982) "Finnish Syllable Structure," unpublished ms., MIT, Cambridge, MA.
- Kiparsky, P. (1967) "Sonorant Clusters in Greek," Language 43, pp. 619-635.
- _____, (1973) "'Elsewhere' in Phonology" in S.R. Anderson and P. Kiparsky, ed., A Festschrift for Morris Halle, Holt, Rinehart and Winston, New York, NY.
- _____, (1979) "Metrical Structure Assignment is Cyclic," Linguistic Inquiry 10, pp. 421-441.
- _____, (1981) "Remarks on the Metrical Structure of the Syllable" in W. Dressler et al., ed., Phonologica 1980, Innsbruck.
- _____, (1982 to appear) "Lexical Phonology and Morphology" in I.-S. Yange, ed., Linguistics in the Morning Calm, Seoul, Korea.
- Koster, W.J.W. (1952) Traitt  de Metrique Grecque, 2nd ed., Leyden.
- Kretschmer, P. and Locker, E. (1963) R ckl ufiges W rterbuch der griechischen Sprache, Vandenhoeck and Ruprecht, G ttingen.
- K hner, R. and Holzweissig, F. (1966) Ausf hrliche Grammatik der Lateinischen Sprache, Verlag Hahnsche Buchhandlung, Hannover.
- Leben, W. (1973) Suprasegmental Phonology, Doctoral dissertation, MIT, Cambridge, MA.

- Leben, W. (1980) "A Metrical Analysis of Length," Linguistic Inquiry 11.3, pp. 497-509.
- Lejeune, M. (1972) Phonétique du Grec Ancien et du Mycénien, Klincksieck, Paris.
- Liberman, M. and Prince, A. (1977) "On Stress and Linguistic Rhythm," Linguistic Inquiry 8.2, pp. 249-336.
- Liddell, H.G. and Scott, R. (1966) A Greek-English Lexicon, Clarendon Press, Oxford.
- Lowenstamm, J. (1981) "On the Maximal Cluster Approach to Syllable Structure," Linguistic Inquiry 12.4, pp. 575-604.
- Lupas, I. (1972) Phonologie du Grec Attique, Mouton, The Hague.
- McCarthy, J.J. (1979) Formal Problems in Semitic Phonology and Morphology, Doctoral dissertation, MIT, Cambridge, MA.
- _____, (1981) "The Representation of Consonant Length in Hebrew," Linguistic Inquiry 12.2, pp. 322-327.
- _____, (1982) "Prosodic Organization in Morphology," unpublished ms., University of Texas/ Austin, Austin, TX.
- Magnien, V. (1920) "L'alternance rythmique chez Homère," Mémoires de la Société de Linguistique de Paris 22.2, pp. 70-94; 22.3, pp. 113-139.
- Marantz, A. (1982) "Re Reduplication," Linguistic Inquiry 13.3.
- Mazon, P. (1942) Introduction à l'Iliade, Société d'Édition "Les Belles Lettres", Paris.
- Meister, R. (1882) Die griechischen Dialekte auf Grundlage von Ahrens' Werk dargestellt I: Asiatisch-aeolisch, Boeotisch, Thessalisch, Göttingen.
- Mohanan, K.P. (1982) Lexical Phonology, Doctoral dissertation, MIT, Cambridge, MA.
- Nagy, G. (1970) Greek Dialects and the Transformation of an Indo-European Process, Harvard University Press, Cambridge, MA.
- Parry, M. (1934) "The Traces of the Digamma in Ionic and Lesbian Greek," Language 10, pp. 130-144.
- Postgate, J.P. (1925) On Ancient Greek Accentuation, London.
- Prince, A.S. (1980) "A Metrical Theory of Estonian Quantity," Linguistic Inquiry 11.3, pp. 511-562.

- Pulgram, E. (1975) Latin-Romance Phonology: Prosodics and Metrics, Wilhelm Fink Verlag, München.
- Quicherat, L. (1899) Thesaurus Poeticus Linguae Latinae, 28th ed., augmented by E. Chatelain, Hachette, Paris.
- Rotenberg, J. (1978) The Syntax of Phonology, Doctoral dissertation, MIT, Cambridge, MA.
- Saib, J. (1976) A Phonological Study of the Tamazight Berber Dialect of Ayt Ndhir, Doctoral dissertation, UCLA, Los Angeles, CA.
- _____, (1978) "Segment Organization and the Syllable in Tamazight Berber" in Bell and Hooper (1978).
- Sapir, J.D. (1965) A Grammar of Diola Fogny, West African Language Monographs 3, Cambridge University Press, Cambridge, England.
- Schade, J. (1908) De Correptione Attica, dissertatio inauguralis Greifswald.
- Schein, B. (1981) "Spirantization in Tigrinya" in Borer and Aoun (1981).
- Selkirk, E. (1981) "Epenthesis and Degenerate Syllables in Cairene Arabic" in Borer and Aoun (1981).
- _____, (1982) "On the Major Class Features and Syllable Theory," unpublished ms., MIT and University of Massachusetts/Amherst.
- Sezer, E. (1982) "An Autosegmental Analysis of Compensatory Lengthening in Turkish," paper read at the Compensatory Lengthening Mini-festival, Harvard University, May 1982, Cambridge, MA.
- †
Simpson, J. and Heath, J. (1982) "Warumungu Sketch Grammar," unpublished ms., MIT and Harvard University, Cambridge, MA.
- Smyth, H.W. (1974) The Sounds and Inflections of Greek Dialects, vol. I: Ionic, Georg Olms Verlag, Hildesheim.
- _____, (1956; repr. 1976) Greek Grammar, Harvard University Press, Cambridge, MA.
- Sommerstein, A.H. (1973) The Sound Pattern of Ancient Greek, Basil Blackwell, Oxford.
- Steriade, D. (1979) "Degenerate Syllables and the Accentual System of Ancient Greek," unpublished ms. MIT, Cambridge, MA.
- _____, (1982) "Cycle-final Glides in Latin," unpublished ms. MIT, Cambridge, MA.
- Sturtevant, E.H. (1940) The Pronunciation of Greek and Latin, Ares Publishers, Chicago, IL.
- Thumb, A. (1959) Handbuch der Griechischen Dialekte, zweite erweiterte Auflage von A. Scherer, Carl Winter, Heidelberg.

- Vendryes, J. (1945) Traité d'Accentuation Grecque, Klincksieck, Paris.
- White, J.W. (1912) The Verse of Greek Comedy, MacMillan, London.
- Whitney, W.D. (1885) The Roots, Verb-forms and Primary Derivatives of the Sanskrit Language, Breitkopf und Härtel, Leipzig.
- _____, (1889) Sanskrit Grammar, Harvard University Press, Cambridge, MA.
- Williams, E. (1976) "Underlying Tone in Margi and Igbo," Linguistic Inquiry 7.3, pp. 463-484.
- Withgott, M.M. (1982) Segmental Evidence for Phonological Constituents, Doctoral dissertation, University of Texas/ Austin, Austin TX.
- Yip, M. (1982) "Reduplication and CV Skeleta in Chinese Secret Languages," paper read at NELS XII, November 1981, MIT, Cambridge, MA.
- Zirin, R. (1970) The Phonological Basis of Latin Prosody, Mouton, The Hague.
- * Carlson, L. (1978) "Word Stress in Finnish", unpublished ms. MIT.
- l Hayes, B. (1980) A Metrical Theory of Stress Rules, Doctoral dissertation, MIT. (available from Indiana University Linguistic Club, Bloomington, Indiana)
- l Pesetsky, D. (1979) "Russian Morphology and Lexical Theory" , unpublished ms. MIT.
- † Simpson, J. (1979) "Australian English Dark l's" , unpublished ms. MIT.