

ASPECTS OF HOPI GRAMMAR

by

LAVERNE MASAYESVA JEANNE

B.S., Northern Arizona University  
(1968)

M.A., University of Arizona  
(1971)

SUBMITTED IN PARTIAL FULFILLMENT  
OF THE REQUIREMENTS FOR THE  
DEGREE OF

DOCTOR OF PHILOSOPHY

at the

MASSACHUSETTS INSTITUTE OF TECHNOLOGY

JUNE, 1978

© LAVERNE MASAYESVA JEANNE 1978

Signature of Author *Laverne Masayesva Jeanne*.....  
Department of Linguistics & Philosophy,  
May 16, 1978

Certified by: *[Signature]*.....  
, Thesis Supervisor

Accepted by: *[Signature]*.....  
HUM. Chairman, Department Committee



I dedicate this thesis to all Native Americans  
who are active in the struggle  
to retain their native languages.

## ASPECTS OF HOPI GRAMMAR

by

LAVERNE MASAYESVA JEANNE

Submitted to the Department of Linguistics & Philosophy  
on May 16, 1978 in partial fulfillment of the requirements  
for the Degree of Doctor of Philosophy.

## ABSTRACT

This thesis concerns various aspects of Hopi Grammar. In Chapter 1, a brief sketch of some major phonological processes of Hopi is given. In Chapter 2, an elementary sketch of Hopi morphology and surface syntax is presented. The purpose, then, of the first two chapters is primarily to provide the reader with a basic orientation to Hopi.

In Chapter 3, an apparent constraint on relative clause formation is discussed. When the relative clause modifies the subject in the matrix sentence, the relativized NP must itself be a subject--hence, the Subject Constraint. Two competing analyses are considered, briefly, in an attempt to explain the constraint. However, a further consideration of data reveals that the constraint on relative clauses appearing in subject position does not, in fact, exist. Specifically, topic-comment structures violate the constraint, nevertheless, well-formed sentences result. The conclusion is that a more accurate accounting of the Subject Constraint hinges upon an analysis of case marking which recognizes an intimate interaction between the category case and the pervasive system of obviation which operates in the formation of relative clauses. As a by-product of the total analysis, a conception of base structures emerges which suggest an answer to a rather long-standing question in regard to Hopi morphology--namely, the identity of the element /-qa/ which is attached to the verb in relative clauses and factive complements.

Chapter 4 is concerned primarily with the phenomenon of obviation in Hopi. An attempt is made to arrive at a maximally general expression of this pervasive principle. In order to accomplish this purpose, it has been necessary to develop an

elementary theory of Hopi phrase structure within the X-bar framework. In addition to the discussion of obviation, it is suggested that the phenomenon of number agreement can also be expressed in an extremely general way.

Thesis Supervisor: Kenneth Hale

Title: Professor of Linguistics

## ACKNOWLEDGEMENTS

It is one man's dream to see the day when Native Americans will come to dominate the field of Native American Linguistics, a day when linguist and informant are one and the same individual. The man of whom I speak is my friend, mentor, and colleague, Ken Hale. It is to this end that Ken has given of himself unselfishly. This thesis surely would not have been possible had it not been for Ken's patience in times of confusion, encouragement in times of despair. I too share Ken's dream and it is my sincere hope that this work is but a mere first step in a larger movement which must come to exist.

I would also like to take this opportunity to thank Sally Hale, who not only provided moral support, but who also gave of her time, ungrudgingly, so that Ken could work with his Indian students full time. To Ken and Sally: ?askwali. paypi niŋ<sup>w</sup>ipi ?itam so?soyam ?aŋ nōŋa.

I am also indebted to my teachers at M.I.T.: Paul Kiparsky, Noam Chomsky, Morris Halle, Haj Ross, and Dave Perlmutter. From them I learned generative theory.

Finally, I am grateful to my friends and colleagues in Arizona, Dick and Kerry Demers, Ellavina Tsosie-Perkins, Adrian Akmajian, Gary Foulke, Susan Steele, and Adrienne Lehrer, for their encouragement and support. To my partners,

Richard and Po<sup>?</sup>k<sup>y</sup>aya, thank you for standing by me when the going got rough. Thanks also to my typist, Dorothy Shank, for a splendid job on the typing.

## TABLE OF CONTENTS

	Page
PREFATORY REMARKS .....	10
CHAPTER 1: REMARKS ON HOPI PHONOLOGY .....	11
1.0. Introduction .....	11
1.1. The Phonological Segments of Hopi .....	11
1.2. Major Phonological Rules--Vowel Deletion and Shortening .....	16
1.3. Reduplication .....	23
1.4. The Hopi Stress Rule .....	32
1.5. The Treatment of Pre-Consonantal Laryngeals; the Genesis of Falling Tone .....	44
1.6. The /p/ to /v/ Rule .....	53
1.7. Final-Vowel Deletion and Pausal Forms .....	62
CHAPTER 2: INTRODUCTORY REMARKS ON HOPI MORPHOLOGY AND SYNTAX .....	72
2.0. Introduction .....	72
2.1. The Number Category in Hopi .....	72
2.1.1. The Morphology of Number-Marking in the Nominal System .....	77
2.1.2. The Morphology of Number-Marking in the Verbal System .....	85
2.1.3. Subject Agreement .....	93
2.1.4. Rules of Agreement .....	99
2.2. Case Marking .....	101
2.2.1. Nouns .....	101
2.2.2. Pronouns and Determiners .....	109
2.3. The Possessive Construction .....	112
2.4. The Postpositional Phrase .....	125

	Page
2.5. The Verb .....	141
2.5.1. Verbal Subcategories .....	142
2.5.2. Remarks on Tense and Aspect .....	163
2.6. Remarks on Sentence Types in Hopi .....	174
2.6.1. Negation .....	174
2.6.2. Questions .....	176
2.6.3. Imperatives .....	179
2.6.4. Particles .....	181
2.7. An Introduction to Subordination in Hopi .....	182
2.7.1. Adjoined Clauses .....	182
2.7.2. Nominalizations .....	184
FOOTNOTES TO CHAPTER 2 .....	186
CHAPTER 3: THE RELATIVE CLAUSE .....	187
3.0. Introduction .....	187
3.1. The Formation of Relative Clauses .....	189
3.2. Data Revealing the Subject Constraint .....	195
3.2.1. The Subject Constraint .....	199
3.3. Elementary Theory of Relative Clauses: the Headed Relative Clause .....	202
3.3.1. The Headless Theory .....	205
3.3.2. Condition on the Raising Rule .....	232
3.4. Some New Facts .....	234
3.4.1. Qa-Case Assignment .....	243
3.4.2. The Surface Structure Constraint .....	245
3.5. The Nature of the "Head" in Relative Clauses ..	251
3.6. The Nature of Nominalized Sentences and the So-Called Complementizer /-qa/ .....	265
3.7. Conclusions and Summary .....	282
CHAPTER 4: THE HOPI RULE .....	288
4.0. Introduction .....	288



	Page
4.1. The non-Coreference Rule .....	289
4.2. Disjoint Reference .....	293
4.2.1. A First Hopi Rule .....	297
4.2.2. A Second Hopi Rule .....	299
4.2.3. A Third Hopi Rule .....	304
4.2.4. A Fourth Hopi Rule .....	307
4.3. Discussion .....	310
4.3.1. An Elementary X-bar Theory for Hopi ...	312
4.3.2. A General Statement of the Hopi Rules .	329
4.3.3. Missing NP's .....	339
4.3.4. Hopi Number Agreement .....	345
4.3.5. A Reconsideration of Nominalizations ..	348
REFERENCES .....	355

....hal, paypi....

paypi niṅ<sup>w</sup>ipi ni? qa hi?ta ?okiw tiwi?yta....

## CHAPTER 1

## REMARKS ON HOPI PHONOLOGY

1.0. Introduction

In the following sections, we present the elements of Hopi phonology. This is not a complete, or finished, analysis but is rather intended as an aid to the reader in coming to grips with regular and semiregular alternation which will be frequently observed in Hopi forms cited in the body of the work.

1.1. The Phonological Segments of Hopi

The purpose of this section is merely to acquaint the reader with the principle articulatory properties of Hopi phonological segments and to introduce the orthography which will be employed in this work.

The inventory of Hopi consonants includes voiceless, unaspirated stops at bilabial and apico-dental positions of articulation, /p, t/, together with a voiceless affricate at apico-alveolar position, /c/, and a variety of voiceless unaspirated stops in the dorso-velar region. These latter include fronted /k<sup>y</sup>/ and backed /q/ dorso-velar stops, as well as stops produced in what might be termed the "neutral" or "normal" dorso-velar position, but with distinctive presence

or absence of lip rounding, /k, k<sup>w</sup>/. The stops /p, t, k<sup>y</sup>, k, k<sup>w</sup>/ are precisely matched in position of articulation by the nasal consonants of Hopi: /m, n, ŋ<sup>y</sup>, ŋ, ŋ<sup>w</sup>/. Hopi possesses a single lateral consonant, /l/, produced with median contact at the apico-alveolar position. The sole remaining "liquid", the rhotic written /r/, is produced in a variety of ways, ranging from an extremely light tap [r] to a retroflexed, i.e. apico-domal, fricative [ʒ], with the latter allophone predominating. This consonant is voiced except in syllable-final position where it is regularly a voiceless apico-domal fricative [ʃ]. The Hopi consonants /v/ and /s/ are consistently fricative. The bilabial fricative--or labio-dental fricative, depending upon the speaker--is voiced, except when it appears syllable-finally, as it may in the Second Mesa dialects (cf. Whorf, 1946). Third Mesa does not have this voiceless variant, since the syllable-final /v/ is not used there--/p/ is used instead in that position (see 1.6. below). The apico-alveolar fricative /s/ is consistently voiceless. In the speech of some, this fricative, and the corresponding affricate /c/ as well, are accompanied by a certain amount of raising in the body of the tongue, producing an affect similar to that of the lamino-alveolars [š] and [č]--this is, no doubt, what is responsible for the use of the digraphs sh and ch in many English renditions of Hopi words (e.g. Kachina, Shungopavi, for Hopi /kacina/, /soŋo<sup>?</sup>pavi/).

The oral glides /w, y/ have the values normally associated with the symbols used here to represent them. Hopi also has two laryngeals--the glottal stop written /ʔ/, and the glottal fricative /h/. These have their usual values in initial and intervocalic positions. Their treatment in pre-consonantal position will be discussed in a latter section (1.5. below).

For convenience of reference, the consonants, glides, and laryngeals of Hopi are assembled in the following chart.

Hopi Nonsyllabic Segments

	bilabial	apico- dental	apico- alveolar	fronted	dorso-velar		rounded	laryngeal
					neutral	backed		
stop	p	t		k <sup>y</sup>	k	q	k <sup>w</sup>	ʔ
affricate			c					
nasal	m	n		ŋ <sup>y</sup>	ŋ		ŋ <sup>w</sup>	
fricative	v		s					h
lateral			l					
rhotic			r					
glide	w			y				

It should perhaps be pointed out that the proliferation of consonants, particularly stops, in the dorso-velar region

is a relatively recent development. The Uto-Aztecan (UA) ancestral language evidently had only \*/k, k<sup>w</sup>/ among its stops and \*/ŋ, ŋ<sup>w</sup>/ among its nasals. The modern /q/ of Hopi appears in UA-derived stems in which the dorso-velar \*k was initial before a non-high back vowel, i.e. UA \*/o, a/ (Hopi /ö, a/), or medial and flanked by non-high back vowels (see e.g. the discussion in Voegelin, and Hale, 1962). Otherwise, either /k/ or /k<sup>y</sup>/ developed. Although the second of these two may well be the variant which properly appears before front vowels, we write the neutral variant /k/ in that environment, since the fronting is not distinctive there--nor is it particularly prominent. It is before the vowel /a/ that the fronting of /k<sup>y</sup>/ is acoustically prominent, and it is only before /a/ that we give it special attention in the orthography. This /k<sup>y</sup>/ appears in UA-derived stems in which an original \*k was preceded by a high vowel and followed by \*a--as in /took<sup>y</sup>a/ 'to sleep, plural' (from UA \*tuka), and in /hok<sup>y</sup>a/ 'leg' (from UA \*huka).

Due to a variety of factors, including phonological changes from Uto-Aztecan, the introduction of loan words, and factors which we do not yet understand, the stops /k<sup>y</sup>, k, q/ are now in "contrast" before the vowel /a/--consider, for example, the words /k<sup>y</sup>aaro/ 'parrot', /kawayo/ 'horse', and /qaa?ö/ 'corn'.

The fronted dorso-velar nasal /ŋ<sup>y</sup>/ also appears before

/a/ in UA-derived stems, under precisely the same conditions as does the stop /k<sup>y</sup>/--e.g. /kooŋ<sup>y</sup>a/ 'husband' (from UA \*kuŋa). It also appears before /a/ in forms whose etymology is not known to us and in which it can not be taken as an allophonic variant of /ŋ/--e.g. /maŋ<sup>y</sup>a/ 'lamb'.

We turn now to a consideration of the vowels of Hopi. The high and mid front vowels /i, e/, the mid back vowel /o/, and the low back vowel /a/ have approximately the cardinal values corresponding to the symbols with which they are written. In addition to these four, Hopi also possesses a high back unrounded vowel, /i/, and a mid front rounded vowel /ö/. These positions of articulation may be charted as follows:

#### Hopi Vowels

	front		back	
	unrounded	rounded	unrounded	rounded
back	i		i	
mid	e	ö		o
low			a	

Hopi distinguishes short and long vowels. The latter are written here as identical vowel clusters, and the overall

integrity of the phonological rules of Hopi indicates that long vowels are indeed sequences of two syllabic segments, at some level of representation, at least (see, for example, the discussions of stress and reduplication below, and see also the discussion in Halle, 1974). Minimal pairs for vowel length are abundant in Hopi: /sihi/ 'flower', /siihi/ 'intestine', /pehi/ 'kangaroo rat', /peehi/ 'some', /taqa/ 'little man', /taaqa/ 'man'.

The rather marked Hopi vowel system continues the ancestral Uto-Aztecan system straightforwardly, except that the provenience of Hopi /e/ (primarily from UA \*a) is not well understood. Hopi /ö/ consistently continues UA \*o; Hopi /o/ continues UA \*u; and the remaining Hopi vowels /i, i, a/ match their Uto-Aztecan sources \*/i, i, a/ precisely. (For an excellent discussion of the development of Uto-Aztecan vowel systems, see Langacker, 1970.)

### 1.2. Major Phonological Rules--Vowel Deletion and Shortening

Observe the following forms:

(1)	<u>Non-future</u>	<u>Future</u>	
	soma	som-ni	'tie'
	so?a	so?-ni	'die (pl)'
7	yin <sup>y</sup> a	yin-ni	'enter (pl)'



It is apparent from (1) that Hopi forms the future by means of a suffix /-ni/. Assuming that future forms are derived by taking a stem /soma/ and appending the suffix /-ni/ to the stem, what we have at an intermediate stage in the derivation is /somani/. Next, /somani/ is subject to a vowel deletion rule--a rule which, presumably, will delete the medial vowel /a/--since the surface form desired is [somni] and not \*[somani]. We might formulate this deletion rule as follows:

Interconsonantal Vowel Deletion

$V \rightarrow \emptyset / VC\_CV$

Now consider the following facts:

(2) <u>Non-future</u>	<u>Future</u>	
?iia	?iy-ni	'plant'
nöosa	nös-ni	'eat'
wiivi	wip-ni	'climb'
piiwi	piw-ni	'sleep'
qaaci	qac-ni	'be in position, inanimate'
siiwi	siw-ni	'dizzy'

caama	cam-ni	'take out'
mooki	mok-ni	'die'
heeva	hep-ni	'seek'
hiiko	hik -ni	'drink'
kiiya	kiiy-ni	'pour'
wiiki	wik-ni	'take along'
took <sup>y</sup> a	tok-ni	'sleep (pl)'
? <sup>2</sup> assi	?as-ni	'wash hair'
siin <sub>i</sub>	si <sub>n</sub> -ni	'peel--as sun- burned skin'
mööya	möy-ni	'dry, dessecate'
haaya	hay-ni	'hang'
?ööyi	?öy-ni	'be seated'
k <sup>w</sup> iiva	k <sup>w</sup> ip-ni	'boil'
piin <sub>i</sub>	pi <sub>n</sub> -ni	'break--as glass (intransitive)'

The data in (2) illustrate future and non-future forms; however, in (2) we encounter a long vowel in the first syllable of the non-future. Much the same observation holds regarding derived future forms, with one additional fact. First, a stem /?iiya/ takes a /-ni/ suffix, giving /?iiyani/. Notice, however, that /?iiyni/--that is, with a long vowel in first syllable--is not the desired surface form. Therefore we must now have a rule that shortens the vowel, or rather, reduces

the identical vowel cluster to a single segment. Presumably the environment for this shortening is created by the prior application of Interconsonantal Vowel Deletion which gives rise to a consonantal cluster. We might formulate the shortening rule as follows:

Pre-cluster Shortening

$V \rightarrow \emptyset / V\_CC$

*but  $V_1 = V_2$  ?*

Following are the derivation of two verbs representative of the two classes mentioned so far:

(3) /soma-ni/	(4) /nöösa-ni/	
∅	∅	Interconsonantal Vowel Deletion
-----	∅	Pre-Cluster Shortening
somni	nösni	Surface Form

Henceforth, we refer to these verbs as "truncating" verbs--alluding to the fact that final vowels in the stem delete

when a suffix is added.

It should be pointed out that it is not only the future suffix /-ni/ that gives rise to vowel deletion, but other suffixes do it as well. For example, the plural suffix /-ya/ will also trigger vowel deletion as seen in (5) below:

(5)	<u>Non-plural</u>	<u>Plural</u>	
	soma	som-ya	'tie'
	so?a	so?-ya	'die'
	caama	cam-ya	'take out'
	?assi	?as-ya	'wash hair'
	etc.	etc.	

Similarly, the nomic, or usitative suffix /-ŋ<sup>w</sup>i/ also creates the condition for deletion:

(5')	<u>Base</u>	<u>Nomic</u>	
	soma	som-ŋ <sup>w</sup> i	'tie'
	caama	cam-ŋ <sup>w</sup> i	'take out'
	?aasi	?as-ŋ <sup>w</sup> i	'wash hair'
	wiiki	wik-ŋ <sup>w</sup> i	'take along'
	etc.	etc.	

Now that we have established the existence of the two major phonological rules of Hopi, we must now address the question of whether the conditions under which they operate are purely phonological. Let us consider Interconsonantal Vowel Deletion first. This rule states that whenever a vowel appears in the environment VC\_\_CV, that vowel must delete. This implies that strings of the kind VCVCV could not exist, since the medial vowel must always delete, according to this rule. The Hopi facts are otherwise, however. Consider the following counterexamples to Interconsonantal Vowel Deletion:

(6)	<u>Non-future</u>	<u>Future</u>	
	maqa	maqa-ni	'give'
	tiwa	tiwa-ni	'find'
	pana	pana-ni	'put in'
	qati	qati-ni	'sit'
	tiki	tiki-ni	'cut'
	sowa	sowa-ni	'eat'
	ŋi?a	ŋi?a-ni	'catch'
	mi?a	mi?a-ni	'shoot'
	piti	piti-ni	'arrive'
	?öki	?öki-ni	'arrive (pl)'
	ti?i	ti?i-ni	'buy'
	paki	paki-ni	'enter'

cok <sup>y</sup> a	cok <sup>y</sup> a-ni	'place on top'
?inta	?inta-ni	'scoop up'
yiki	yiki-ni	'finish, make'
?oya	?oya-ni	'put things'

If Interconsonantal Vowel Deletion were strictly phonological, presumably [maqa-ni] should be \*[maq-ni]; [tiwa-ni], \*[tiw-ni], and so forth. But in fact they are not.

While numerous exceptions exist for verbs that have short vowels in the first syllable, as seen in (6) above, counter-examples are less common for verbs that have long vowels. Observe the following:

(7) <u>Non-future</u>	<u>Future</u>	
tiiva	tiiva-ni	'throw away'
miima	miima-ni	'roll away'
niina	niina-ni	'kill'
piin <sup>y</sup> a	piin <sup>y</sup> a-ni	'break--as glass (transitive)'
peena	peena-ni	'write'
kiiki	kiiki-ni	'bite'
siin <sup>y</sup> a	siin <sup>y</sup> a-ni	'peel'
hööna	hööna-ni	'wipe'
hoona	hoona-ni	'send away'

If the rules applied without exception, the future form [kiiki] would be \*[kik-ni]; [miima-ni] would be \*[mim-ni], and so forth. But they are not. Thus, the forms in (7) present counter-examples to Interconsonantal Vowel Deletion (and, therefore but irrelevantly to Pre-Cluster Shortening). Let us refer to these classes of exceptions--namely (6) and (7)--as "non-truncating" verbs.

So far as we can tell, it is not possible to predict whether a verb will belong to the truncating or non-truncating class. We conclude, therefore, that the rule is morphologically conditioned--that is to say, linguistic forms which satisfy the strictly phonological conditions of the rule, must be marked, perhaps by means of a lexical feature of some sort, to indicate whether or not they actually undergo it.

### 1.3. Reduplication

We present now an analysis of a process very common in Hopi, namely reduplication. Reduplication is one of the ways in which Hopi plurals are formed, and it is the reduplication of nouns only that we will describe in this discussion.

Throughout the section we assume that reduplication precedes the phonological rules--in particular, it precedes the two phonological rules discussed in section 1.2.. Finally, we assume that reduplication involves a copying of material contained in the initial syllable and that the copied material

appears to the left of the initial syllable of the base.

We begin by looking at some classes of data. We examine first, disyllabic nouns. Both (8) and (9) illustrate singular and plural forms; however, in (9), we encounter a long vowel (i.e. VV) in the first syllable.

(8)	<u>Singular</u>	<u>Plural</u>	
	koho	kokho	'wood'
	como	cocmo	'hill'
	sihi	sishi	'flower'
	leŋi	lelŋi	'tongue'
	laho	lalho	'bucket'
	poyo	popyo	'knife'
	k <sup>w</sup> asa	k <sup>w</sup> ak <sup>w</sup> sa	'dress'
	tamö	tatmö	'knee'
	siri	sisri	'tail'
	tama	tatma	'teeth'

(9)	<u>Singular</u>	<u>Plural</u>	
	saaqa	saasaqa	'ladder'
	tooci	tootoci	'shoe'
	siivi	siisivi	'pot'
	sooya	soosoya	'planting stick'



ʔaaya	ʔaaʔaya	'rattle'
soohi	soosohi	'star'
noova	noonova	'food'
siiva	siisiva	'metal'
moosa	moomosa	'cat'

In (8) we see that in the plural forms the repeated material consists of the consonant and the first vowel of the stem. The stem itself is shortened by loss of its first vowel. In (9), the repeated material consists of the consonant and the first two vowels of the stem. Again, the latter is shortened by the loss of a vowel. One obvious proposal is to say that when the stem vowel is short, repeat the initial consonant and the first vowel, and when the stem vowel is long, (i.e. VV), repeat the initial consonant and the first two vowels.

However, it seems to us that much greater generalization can be achieved by simply assuming that reduplication is accomplished by repeating the first syllable with a long (i.e. VV) vowel, regardless of whether the stem vowel is long or short. That is, we are suggesting that reduplication is formulated as follows:

(10) Reduplication

S.D.: # C-V-X  
           1 2 3 4  
 S.C.: 1 2 3 3 2 3 4

According to this formulation, /koho/ would reduplicate as /kookoho/. The rules needed to give the surface form [kokho] are first, Interconsonantal Vowel Deletion and second, Pre-Cluster Shortening, applying in that order. These rules are independently needed, as we have seen in section 1.2. above.

Now consider long-vowel stems. According to our reduplication rule, /sooya/ would reduplicate as /soosooya/. What is needed now is a deletion or shortening rule which will delete a vowel from the second long syllable. A slight modification of Interconsonantal Vowel Deletion will produce exactly this effect. The modified rule appears as follows:

$$V \rightarrow \emptyset / VC\_C_0V$$

Let us now refer to this rule as Intersyllabic Vowel Deletion, since it is no longer necessary that the second consonant be present. The rule applies to /soosooya/ giving [soosoya].

Notice that Intersyllabic Vowel Deletion as it is formulated now, will also delete, incorrectly, a medial vowel in yet another class of nouns having consonant clusters in medial position. Observe the following:

(11) <u>Singular</u>	<u>Plural</u>	
naqvi	naanaqvi	'eat'
tisna	tiitisna	'body dirt'
napna	naanapna	'shirt'
ɲimni	ɲiiɲimni	'flour'

Intersyllabic Vowel Deletion will apply to these forms, giving, at some intermediate stage in the derivation, \*/naanqvi/, \*/tiitsna/, and so forth. (These, of course, are subject to Pre-Cluster Shortening so that we end up with the surface forms \*[nanqvi], \*[titsna].) In order to prevent this rule from applying, we specify that the maximum number of consonants that can be present in the second syllable is one. Therefore, the final version of Intersyllabic Vowel Deletion appears as follows:

Intersyllabic Vowel Deletion

$$V \rightarrow \emptyset / VC\_C_0^1V$$

All the examples given so far are dissyllabic stems, either with a long or short vowel in the stem. Reduplication, as it is formulated, will also handle polysyllabic nouns:

(12) <u>Singular</u>	<u>Plural</u>	
caqapta	cacqapta	'dish'
kiyapi	kikyapi	'dipper'
panapca	papnapca	'window'
yin <sup>y</sup> api	yiny <sup>y</sup> api	'plaque'
möcikvi	mömcikvi	'trash'
mirikho	mimrikho	'hunting stick'
pitanakci	piptanakci	'hat'
melooni	memlooni	'melon'
qötösompi	qöqtösompi	'headband'
kawayvatna	kakwayvatna	'watermelon'

Reduplication and other related processes apply regularly to these nouns as well. Thus, for example, [cacqapta] is derived as follows:

(13) /caacaqapta/

∅	Intersyllabic Vowel Deletion
∅	Pre-Cluster Shortening
[cacqapta]	Surface

There are a number of forms that are exceptions either to reduplication or to the phonological processes that normally effect reduplicated stems, or both. Consider first, the following cases:

(14) <u>Singular</u>	<u>Plural</u>		
	(a)	(b)	
leŋi	leleŋi	leeleŋi	'tongue'
ŋahi	ŋaŋhi	ŋaanahi	'medicine'
?owa	?o?wa	?oo?owa	'stone'
k <sup>w</sup> ite	k <sup>w</sup> ik <sup>w</sup> te	k <sup>w</sup> iik <sup>w</sup> ite	'braid'

Notice that two plural forms are given; both forms are equally correct. It is not the case that either (a) or (b) are exceptions to reduplication; both reduplicate in normal fashion. Column (a) forms, however, have undergone the phonological processes in the expected fashion. That is,

(15) /leeleni/

∅	Intersyllabic Vowel Deletion
∅	Pre-Cluster Shortening
leeni	Surface

Column (b) forms, on the other hand, have undergone no other rules. Therefore, (b) forms are exceptional, not to reduplication, but rather to the phonological rule of Intersyllabic Vowel Deletion. The failure of this rule results also, of course, in the failure of Pre-Cluster Shortening.

As we have just seen, apparently Intersyllabic Vowel Deletion is optional for some nouns (e.g. [leeni]~[leeleni], etc.). There is at least one noun we know of, however, whose reduplicated form never undergoes Intersyllabic Vowel Deletion. Thus, the plural of [taci] 'ball' is never \*[tatci]; instead, it is consistently [taataci].

Another class of nouns which is exceptional include the following:

(16) <u>Singular</u>	<u>Plural</u>	
koyono	kokoyont	'turkey'
?aη <sup>w</sup> isi	?a?aη <sup>w</sup> ist	'crow'
laqana	lalaqant	'squirrel'

qapirra	qaqapirt	'goat'
tokoci	totokoct	'wild cat'

These are exceptional in two ways: first, they are exceptions to Intersyllabic Vowel Deletion since we do not get \*[kokyoŋt]. Second, they are exceptions to the reduplication rule itself--in that they have a short vowel in the first syllable of the reduplicated form. We will assume, therefore, that these are straightforward exceptions to the prevailing reduplication pattern. Interestingly, these nouns have an additional property in common--they are all poly-syllabic animate nouns. They constitute, therefore, a natural class of exceptions.

Finally, there are some exceptions which are simply irregular. For example, the plurals of [poʔko] 'dog' and [moʔci] are [popkot] and [momci] respectively. However, if we assume that the reduplicated forms are based on /poko/ and /moci/ then their plurals are regular--the irregularity consists rather in that these nouns employ special base forms different from the singular forms. The word [maana] 'girl' reduplicates as [mamant]; one would expect \*[maamant]. Similarly, one would expect the plural of [taaqa] 'man' to be \*[taataqt], but it isn't; instead, we have [taʔtaqt]. (For the phonetic value of /ʔ/ see section 1.5. below.)

#### 1.4. The Hopi Stress Rule

For the most part, stress is predictable in Hopi. Basically, the assignment of stress conforms to the following principles:

- (a) The second vowel, counting from the left, is stressed in polysyllabic words (i.e. words which are trisyllabic or longer) in which the first vowel is followed by a single consonant or directly by a vowel. (In calculating the length of a word, VV sequences count as disyllabic.)
- (b) The first vowel is stressed otherwise--i.e. in disyllabics, and in polysyllabics whose first vowel is followed by a consonant cluster.

These principles may be expressed in the form of a rule as follows:

#### Stress Assignment

$$V \rightarrow \hat{V} / \# C (VC_0^1) \_ C_0 V \dots \# ,$$



in which # indicates word boundary and in which the elipsis stands for any sequence, possibly null, of phonological segments.

In accordance with the standard conventions for interpreting phonological rules, this expression will be understood to combine the following two subrules:

- (a')  $V \rightarrow \hat{V} / \# CVC_0^1 \_ C_0 V \dots \#$   
 (b')  $V \rightarrow \hat{V} ; \# C \_ C_0 V \dots \# ,$

disjunctively ordered as given. The first of these subrules assigns stress to polysyllabics whose first vowel is followed by a single consonant (including glide or laryngeal under the term 'consonant' here), as in

- |             |                 |
|-------------|-----------------|
| (17) kiyápi | 'dipper'        |
| caqápta     | 'dish'          |
| panápca     | 'window'        |
| míríkho     | 'hunting stick' |
| qötósompi   | 'headband'      |
| koyóno      | 'turkey'        |
| laqána      | 'squirrel'      |

sakína	'grey squirrel'
yi?á?ata	'to speak'
tayáti	'to laugh'

and to polysyllabics whose first vowel is followed directly by another vowel--i.e. whose first vowel forms the initial segment in a so-called 'long vowel', as in

(18) taávo	'cottontail'
siíhi	'intestine'
soóya	'planting stick'
?ááya	'rattle'
toóci	'shoe'
tiík <sup>w</sup> avi	'necklace'
paáwik <sup>y</sup> a	'duck'
moóki	'to die'
hiíko	'to drink'
piíwi	'to sleep'
naáwisi	'to comb one's own hair'
naátihota	'to hurt oneself'

The second subrule--i.e. (b')--represents the 'otherwise case'.

It assigns initial stress to disyllabics, as in

(19) kóho	'wood'
cómo	'hill'
síhi	'flower'
láho	'bucket'
máŋ <sup>y</sup> a	'lamb'
wári	'to run'
tíwa	'to see, find'
máqa	'to give'
sóma	'to tie'
nápna	'shirt'
náqvi	'ear'

And it also assigns initial stress to polysyllabics not subsumed under (a')--i.e. those whose first vowel is followed by a consonant cluster:

(20) ?ácvewa	'chair'
léstavi	'viga, roof beam'
cáyhoya	'child (diminutive)'

Among polysyllabics of this type are those in which a medial cluster has arisen in the course of reduplication and subsequent vowel deletion (see 1.3. above). Stress, quite clearly, is assigned after the vowel deletion by means of which the cluster arises. This accounts for the apparent 'stress shift' observed in such singular-plural pairs as

(21) <u>Singular</u>	<u>Plural</u>	
caqápta	cácqapta	'dish'
panápca	pápnapca	'window'
miríkho	mímrikho	'hunting stick'
qötósompi	qóqtösompi	'headband'
kiyápi	kíkyapi	'dipper'

In addition to forms successfully accommodated by the stress rule, Hopi also possesses a number of monosyllabics which receive stress. For example

(22) pám	'he/she'
pít	'him/her'
?ép	'at, in (postposition)'
kír	'concessive (particle)'

As monosyllabics, these are not accommodated by our stress rule. There is some evidence (coming from the so-called 'pausal form', among other things; see 1.7. below, and see also Whorf, 1946) that such monosyllabics are underlyingly disyllabic

- (23) /pami/  
       /pita/  
       /?epe/  
       /kira/

and that their final vowel is lost through the action of a special final-vowel deletion process which affects a large number of what might, in this particular context at least, be termed 'minor categories' (e.g. postpositions, determiners, particles, and certain endings; see 1.7. below). If forms of the type represented by the above list are disyllabic at the time the stress rule applies, then the latter, as it stands, will accommodate them of course. Similarly, the stress rule would also correctly assign stress to the second of two identical vowels in such 'minor category' morphemes as

(24) ?iíc	'early'
paás	'carefully'
siís	'once'
löö́s	'twice'
naát	'still, yet'

assuming, of course, that these end in vowels at the time stress is assigned. If, on the other hand, stress is assigned directly to surface profiles of the form C(V)VC, then a special provision must be made for them. For the present purposes, we will assume the latter and provide a special 'minor' stress assignment rule of the following form:

(c) Minor Stress Assignment

$$V \rightarrow \acute{V} / \# C (V) \_ C \#.$$

We must now consider forms which are straightforward exceptions to the stress assignment rule. The vast majority of these are morphemically complex, consisting of a base followed by an ending. Consider, for example, verb forms consisting of a verbal base, or theme, followed by the future suffix /-ni/ or the nomic suffix /-ŋ<sup>w</sup>i/:

(25) <u>Future</u>	<u>Nomic</u>	
máqani	máqaŋ <sup>w</sup> i	'give'
wárikni	wárikŋ <sup>w</sup> i	'run'
mí?ani	mí?aŋ <sup>w</sup> i	'shoot'
távini	táviŋ <sup>w</sup> i	'put, send'

The surface segmental profiles of these words satisfy the condition specified in subrule (a') for the assignment of stress to the second vowel, rather than to the first vowel as is actually the case. It is conceivable that these are not truly exceptional, however, and the ending is separated from the verbal base by a word boundary (#). And there is indeed a sense in which the suffixes here are less firmly attached to the verbal theme than is, for example, the base-forming suffix /-ti/, as in /tayati/ (stressed [tayáti]) 'to laugh', which does not, from the point of view of stress assignment, behave like a separate word. The tense-aspect endings, and certain other endings as well, can be 'stranded' as a result of verb (or verb phrase) deletion, for example, as in

(26) ?i-tipko pit mi?a-q pi? ni? tiwat GAP-ni.

(my-YBro it shoot-fut-conj then I too GAP-fut)

'When my younger brother shoots it, I will too.'

from the fuller

- (27) ?i-tipko pit mi?a-q pi? ni? tiwat pit mi?a-ni.  
 (my-YBro it shoot-fut-conj then I too it shoot-fut)  
 'When my younger brother shoots it, I will shoot  
 it too.'

It is, therefore, not unreasonable to assume that the boundary which separates these endings from the verbal theme is a word boundary rather than, say, a formative boundary such as would presumably intervene between the root /taya-/ and the base-forming suffix /-ti/ in the verb /tayati/ 'to laugh'.

If there is, in fact, a word boundary in the forms at issue here--i.e. if they are

maqa#ni

maqa#ŋ<sup>w</sup>i,

and so on--then they are not, after all, exceptions to the stress assignment rule. The rule will apply correctly to assign initial stress in conformity with subrule (b'), since the verbal base is flanked by #-boundaries.



A solution of this nature seems justifiable to us in the case of morphemically complex forms for which there exists some independent, syntactic or morphological, evidence for a degree of separation between the base and the suffix--as there clearly is in the case of the tense-aspect endings, the suffixal conjunctions (see 1.7. below), and certain other suffixal elements, which may be stranded as a result of verb deletion. There are, however, forms for which the stranding test does not provide evidence for an internal #-boundary but which have exceptional stress placement in exactly the same sense as do the future and nomic forms considered above. These include, for example, words formed from disyllabics by means of the case endings [-t] (</-ta/) and [-y] (</-yi/), and the non-singular endings [-m] (</-mi/) and [-t] (</-ti/). Such words would not, of course, be exceptional if stress were assigned subsequent to the deletion of their final vowels (a deletion which is effected by the minor rule discussed in 1.7.). But there still remain a large number of exceptional forms in the realm of derivational morphology, involving theme-forming suffixes whose final vowels are not subject to deletion. Typically, these are morphemically complex verb themes which have the property that they are formed by means of a derivational ending added to a base which exists independently as a verb theme. Consider, for example, the causative and goal forms listed below:

mínikna	(cf. /míni/	'to fall')	'cause to fall'
lóhökna	(cf. /löhö/	'to fall from height (pl)')	'cause to fall from height'
wárikna	(cf. /wari/	'to run')	'cause to run'
yámakna	(cf. /yama/	'to exit')	'cause to exit'
tíkito	(cf. /tiki/	'to cut')	'go to cut'
tí?ito	(cf. /ti?i/	'to buy')	'go to buy'
wárikto	(cf. /wari/	'to run')	'go to run'
yámakto	(cf. /yama/	'to exit')	'go to exit'

These have initial stress, rather than the second-vowel stress which their segmental profiles would otherwise allow in accordance with subrule (a'). It is conceivable that derived forms of this type--unlike those of the /tayati/-type whose root (/taya-/ in this instance) does not exist as an autonomous verb theme--contain a #-boundary preceding the derivational suffix. If so, then they can be removed from the exception category.

There remain, however, a number of forms which we--at our present stage of knowledge--can only regard as fully exceptional. These include Hopi-based forms, such as /síkisve/ 'car', with exceptional initial stress, but they also include borrowed forms which, if we are correct in our assumption that the level (or 'rising') tone is to be analyzed as a VV

sequence (see 1.5. below), must have stress assigned to their third vowel, counting from the left. Forms of this latter category include such Spanish derived nouns as the following:

kapiíra	'goat'
kaneélo	'sheep'
meloóni	'melon'
pösaála	'blanket'
mansaála	'apple'

An extremely interesting class of Hopi-based exceptions consists of certain imperfective verb forms marked by reduplication. These are built upon stems of the canonical patterns CV(V)CV, and they are produced by simple repetition of the initial syllable, yielding trisyllabics of the form CVCVCV. These later forms are exceptional in that they exhibit final, rather than the expected penultimate, stress:

<u>Base</u>	<u>Imperfective</u>	
wári	wawarí	'run (nonpl)'
có?o	coco?ó	'jump'
haáwi	hahawí	'climb down'

k<sup>w</sup>iíva                      k<sup>w</sup>ik<sup>w</sup>ivá                      'boil'

Forms which are fully exceptional in this sense will be written with the acute diacritic in our transcription.

1.5. The Treatment of Pre-Consonantal Laryngeals; the Genesis of Falling Tone

In the previous section, it was mentioned that vowel sequences in which the second member is assigned stress (i.e. [V<sup>́</sup>V]) are executed with a level (sometimes perceived as rising) pitch contour. In our Third Mesa dialect there are also long vowels which exhibit a falling pitch contour, as in:

(28) Singular

[wíisi]	'broom'
[k <sup>w</sup> áapi]	'neck'
[náapi]	'leaf'
[kóok <sup>y</sup> an]	'spider'
[náaqa]	'earring'
[wíiti]	'woman'

For the moment we represent the falling-toned long vowels as

[V̆V].

The purpose of this section is to discuss the genesis of this falling tone. One clue to its genesis is provided by the plurals of the nouns in (28):

(29) Plural

wiiwiʔsi

kʷaakʷaʔpi

naanaʔpi

kookoʔkʷaŋ

naanaʔqa

wiiwiʔtim

Assuming that these plural forms are arrived at by our reduplication rule (described in section 1.3.), the singular base of a form like /wiiwiʔsi/ must be /wiʔsi/, that is with a non-vocalic segment--evidently a glottal stop /ʔ/--as the first member of a medial cluster. Recall that we have a class of nouns with precisely this CVCCV canonical pattern, to wit /naqvi/, /patŋa/, etc., whose reduplicated shapes match precisely those of the nouns with which we are now concerned:

C V V C V C C V

n a a n a q v i

w i i w i ? s i

Thus, if we assume that the stems with falling tone are of this CVCCV canonical shape--i.e. if they are

wi?si

k<sup>w</sup>a?pi

na?pi

ko?k<sup>y</sup>an

na?qa

wi?ti,

then their reduplicated forms will follow automatically.

But in order to account for the singulars of these nouns, we must postulate an additional rule. Specifically, we must have a rule which will convert the putative laryngeal segment /ʔ/ into a vocalic segment:

(30) Laryngeal Vocalization

S.D.:	V	- ? -	C
	[+ stress]		
	1	2	3
S.C.:	1	1	3
		[- stress]	

We assume that falling tone raises in the following fashion: laryngeal vocalization follows stress assignment, and since, in general, unstressed vowels are executed at a lower pitch level than stressed vowels, we hear falling tone. That is, the sequence [V̂V] is perceived as a long vowel with falling tone.

Now we must find independent evidence for the existence of the Laryngeal Vocalization Rule. Partial evidence for this is provided by reduplicated nouns involving an initial glottal stop /ʔ/. According to our analysis, /ʔowa/ 'rock (sg)' should reduplicate as /ʔooʔowa/. Intersyllabic vowel deletion, pre-cluster shortening, and stress assignment then apply, giving [ʔóʔwa]. This, however, is not the actual pronunciation. Notice, however, that we have precisely the right conditions for the application of laryngeal vocalization. It applies, giving [ʔóowa], the desired result. Consider another example of the same type: /ʔinan<sup>w</sup>a/ 'heart (sg)'. It reduplicates as /ʔiiʔinan<sup>w</sup>a/. The two deletion rules and stress apply, giving [ʔíʔnan<sup>w</sup>a]. Once again we have the environment

for Laryngeal Vocalization; it applies, giving [ʔáinan<sup>w</sup>a] 'hearts', the actual pronunciation. Thus it seems that whenever the form X<sup>V</sup>?CX is encountered, laryngeal vocalization applies to give our falling tone [V̂].

It happens, however, that the glottal stop is not the only laryngeal that gives rise to falling tone; /h/ does it as well. Consider the word for 'leg', that is, /hok<sup>y</sup>a/. It reduplicates as /hoohok<sup>y</sup>a/. Again, the major phonological rules apply, including stress assignment, giving at an intermediate stage in the derivation [hók<sup>y</sup>a]. Once again, we have just the environment for Laryngeal Vocalization to apply, assuming it generalizes to both laryngeals. It applies, giving the actual surface form [hók<sup>y</sup>a]. We generalize the rule now to include both laryngeals, /ʔ/ and /h/:

(30') Laryngeal Vocalization

S.D.:	V	C	C
	[+ stress]	[- syllabic - consonantal]	
	1	2	3
S.C.:	1	1 [- stress]	3

Another kind of evidence for laryngeal vocalization is provided by certain suffixed verb forms. Recall, for example,



that verbs form their future by means of the suffix /-ni/. Moreover, as we said, some verbs when they take a suffix, show deletion of their stem-final vowel. For example, the future of /soma/ 'tie' is [somni]. Now compare the future of /soʔa/ 'die (pl)'--this is [sóoni], i.e. with our falling tone. How do we account for this falling tone? The form must be [sóʔni] at an intermediate stage of derivation, since clearly the stem-medial nonsyllabic segment is /ʔ/, as evidenced by the uninflected form /soʔa/. Since this intermediate form has stress on the initial syllable, and since final vowel deletion brings the /ʔ/ into pre-consonantal position, we have precisely the conditions for application of our proposed Laryngeal Vocalization Rule--it applies, giving rise to the surface form [sóoni]. This provides another instance in which a known laryngeal gives rise to falling tone.

Finally, we consider evidence provided by the singular determiners /niʔ/ 'I', /ʔiʔ/ 'this', and /miʔ/ 'that'. Notice that all three of these have a /ʔ/ in final position. In isolation, these pronouns are articulated with a /ʔ/ in final position, or with the final vowel of the pausal form (see 1.7. below). However, in connected speech, the /ʔ/ disappears and instead, we get falling tone. By connected speech we mean the case where a determiner appears in a string with a consonant-initial word following--thus, we have [níi píti] 'I arrived', [ʔíi tíyo] 'this boy', and [míi tíyo] 'that

boy'. Clearly, these surface forms can be accounted for by permitting the Laryngeal Vocalization Rule to apply across word boundaries, as well as word-internally.

In concluding this section, we must introduce certain refinements in our Laryngeal Vocalization Rule in order to accommodate the phenomena observed, for example, in the following non-future/future verb pair

(31) <u>Non-future</u>	<u>Future</u>	
yoohi	yoyni	[yóini] 'shatter (intransitive)'

and in the reduced form of the diminutive suffix /-hoya/, as it appears in the following example:

(32) <u>Base</u>	<u>Diminutive</u>	
maana	manawya	[manáuya] 'girl'

Observe that, in these cases, the vowel which results from application of the vocalization rule is not a copy of the preceding stressed vowel but rather a vowel which retains certain essential qualities of the vowel which originally followed the

laryngeal. We propose to handle this in the following way. We will assume that a laryngeal assimilates to a following high front or rounded vowel--that is, it takes on the fronting and rounding features associated with an immediately following vowel. A rule of roughly the following form will accomplish this assimilation:

(33) Laryngeal Assimilation

$$\begin{array}{c} C \\ \left[ \begin{array}{l} - \text{syllabic} \\ - \text{consonantal} \end{array} \right] \rightarrow \left[ \begin{array}{l} \alpha \text{ back} \\ \beta \text{ round} \end{array} \right] / \text{---} \left[ \begin{array}{l} \alpha \text{ back} \\ \beta \text{ round} \end{array} \right] \end{array}$$

Actually, this sort of assimilation is not restricted to laryngeals. Ultimately, the rule should be generalized to embrace the assimilation observed in velars, and readily perceivable, for example, in the future form [hik<sup>w</sup>ni], from /hiiko + -ni/. For our present purposes, however, we will be content with the rule as formulated above.

Given this assimilation rule, we have the following partial derivations:

(34) /yoohi+ni/                      /mana+hoya/

yooh <sup>y</sup> ini	manah <sup>w</sup> oya	Laryngeal Assimilation
yooh <sup>y</sup> ni	manah <sup>w</sup> ya	Intersyllabic V-Deletion
yoh <sup>y</sup> ni	-----	Pre-Cluster Shortening
yóh <sup>y</sup> ni	manáh <sup>w</sup> ya	Stress Assignment

At this point, Laryngeal Vocalization applies. But it must be formulated so as to preserve the rounding and fronting features inherent in the laryngeal. The following is a rough approximation to a rule of the desired effect:

(30'') Laryngeal Vocalization (revised)

S.D.:	V	C	C
	[+ stress]	$\begin{bmatrix} - \text{syllabic} \\ - \text{consonantal} \\ \alpha \text{ back} \\ \beta \text{ round} \end{bmatrix}$	
	1	2	3
S.C.:	1	1	3
		$\begin{bmatrix} - \text{stress} \\ \alpha \text{ back} \\ \beta \text{ round} \end{bmatrix}$	

Applying this rule to the forms in the final lines of the partial derivations given above, we obtain the following surface

forms:

[yóini]

[manáuya]

(Although these actually contain vowel clusters [oi] and [au], we will continue to write them in the way which has become usual in the literature--i.e. with glide symbols, rather than vowel symbols, posttonically.)

#### 1.6. The /p/ to /v/ Rule

In morphemes which begin with /p/ and are capable of undergoing reduplication, the second instance of this consonant, if intervocalic in the reduplicated form, will appear as /v/ rather than /p/. For example:

(35) <u>Singular</u>	<u>Plural</u>	
patna	paavatṇa	'squash'
paasa	paavasa	'field'
piiki	piiviki	'piki'
poosi	poovosi	'eye'
poota	poovota	'coiled plaque'
paahi	paavahi	'water'

paako	paavako	'cottonwood root'
paʔk <sup>w</sup> a	paavak <sup>w</sup> t	'frog'
pöʔsa	pöövöst	'mouse'

This is a vestige of a once completely productive phonological rule of approximately the following form:

(36) p-Lenition

$p \rightarrow v / V\_V$

For many speakers of Hopi, particularly those belonging to older generations, this is still a productive rule. Thus, for example, for those speakers, when the first person singular possessive element /ʔi-/ is prefixed to a /p/-initial noun, that initial consonant, being intervocalic in the resulting form, will lenite to /v/:

(37)	<u>Bare</u>		<u>Prefixed</u>	
	poosi	'eye'	ʔi-vosi	'my eye'
	poyo	'knife'	ʔi-voyo	'my knife'
	paasa	'field'	ʔi-vasa	'my field'

pono	'stomach'	?i-vono	'my stomach'
paava	'elder brother'	?i-vava	'my elder brother'

For many younger generation speakers on the other hand, the conditions for the rule no longer appear to be strictly phonological; and for them the first person singular possessive forms are as follows:

(37')        ?i-posi  
                   ?i-poyo  
                   ?i-pasa  
                   ?i-pono  
                   ?i-pava  
                   ?i-piki

Obviously, p-Lenition has not applied to these forms.

Similarly, the reflexive-reciprocal is formed by prefixing the element /naa-/ to the verb. This also gives rise to intervocalic /p/'s. As in the case of the first person possessive forms of nouns, there is a generational difference according to whether the stem-initial consonant lenites or not. Thus:

(38) <u>Verb</u>	<u>Reflexive-Reciprocal</u>		
	<u>older generation</u>	<u>younger generation</u>	
peena	naa-vena	naa-pena	'to photograph'
paʔaŋ <sup>w</sup> a	naa-vaʔaŋ <sup>w</sup> a	naa-paʔaŋ <sup>w</sup> a	'to help'
porokna	naa-vorokna	naa-porokna	'to pierce self (e.g. ears)'

This array of facts suggests that the rule is being re-analyzed--i.e. as no longer strictly phonological--by younger speakers, a reanalysis, we feel, that is due in part to rule opacity (Kiparsky, 1973, pp. 57-86). In fact, p-Lenition is opaque in two ways--that is to say there are two types of surface exceptions: (1) instances of intervocalic /p/'s, as in the possessive forms cited above as well as in a few unanalyzable forms, such as [wiipa] 'tall', [taapalo] 'shawl', and [hopi] 'Hopi'; and (2) instances of /v/ that are not intervocalic, as in [naqvi] 'ear', [tapvoko] 'pet rabbit', [yokva] 'begin raining', etc..

Another motivation for the suggested reanalysis might well be the elimination of alternations within a paradigm. Notice that if the rule is eliminated, it will result in the circumstances that a /p/-initial noun will be consistently /p/-initial, even when it is combined with a vowel final prefix. Therefore, in the possessive paradigm, for example, the



alternation observed in the older generation between first person singular possessive forms and the other possessive forms will be eliminated:

(39) <u>Older Version</u>	<u>Newer Version</u>
?i-voyo	?i-poyo
?i?-poyo	?i?-poyo
?ita?-poyo	?ita?-poyo
?imi?-poyo	?imi?-poyo

We are tempted to conclude on the basis of these observations that p-Lenition is no longer a live rule for the younger generation. Assuming this to be the case we would find it very natural for there to be doublets involving relics of the earlier stage. There appear to be examples of precisely this kind, of which the most convincing is the following: [?i-poko] alternating with [?i-voko]. The point is this: younger generation speakers have both forms in their speech. Presumably, [?i-voko] represents a relic. Furthermore, --and this is not altogether surprising--a meaning difference has arisen. The form [?i-voko] now translates as 'my automobile', whereas [?i-poko] translates either 'my dog' or 'my pet'.

If we conclude that p-Lenition is no longer a live rule,

we must nonetheless recognize that a p~v alternation is still productive in reduplication. One way to account for this would be to say simply that there is a reduplication-specific p~v alternation--a relic of the historically productive rule. There is, however, another way to account for the p~v alternation in reduplicated stems, --i.e. to assume that all p-initial stems are underlyingly v-initial and that there is a modern rule that takes word-initial /v/ and changes it to [p]. According to this analysis, the derivation of the singular and plural forms of [poosi] 'eye' is as follows:

(40)	<u>Singular</u>	<u>Plural</u>	
	/voosi/	/voovoosi/	
	-----	∅	Intersyllabic Vowel Deletion
	p	p	Initial v→p
	[poosi]	[poovosi]	Surface Representation

The Initial v→p Rule can be formulated as follows:

Initial v→p Rule

v→p / # \_\_\_

However, under this analysis we must now account for the fact that the younger generation says [ʔi-poyo] instead of [ʔi-voyo]. This follows because we are claiming that stem-initial [p] comes from /v/. In other words, /ʔi-voyo/ is underlying in our new analysis. It is possible that Initial v→p applies here because the prefix is separated from the stem by means of a word boundary, that is, the underlying form is /ʔi#voyo/.

There is a natural place to look for independent evidence to corroborate this latter suggestion, namely stress assignment (see section 1.4. above). Consider any polysyllabic root, for example, [pitanakci]. In isolation, this is pronounced with stress on the second syllable from the left-- [pitánakci]--in accordance with the stress assignment rule. Now consider the first person singular possessed form based on this noun in younger generation speech. If we are correct in our assumption that the prefix is separated from the stem by #, the prefix should not count in stress assignment. In other words, the stem should have exactly the same stress that it has in isolation. In our speech, at least, this is in fact the case, thus the form is,

[ʔi#pitánakci].

We would predict, moreover, that in the older generation speech--in which the p→v rule is still alive--the prefix would be taken into consideration in stress assignment since, presumably, the prefix is not separated from the stem by a # in older speech. So far as we know, this is in fact the case. Thus, the older form is,

[?i-vítanakci].

We should mention, however, that we do not wish to commit ourselves to this analysis--i.e. in which surface p-initials are underlyingly v-initial. We suggest it as a possibility only.

Finally, if we conclude that the original p-Lenition is no longer a rule, then any intervocalic /v/'s must be underlyingly /v/. That is to say, we cannot now postulate a /p/-source for surface [v]'s appearing in such words as:

(41) k <sup>w</sup> iiva	'to boil'
taavo	'rabbit'
heeva	'to find'
wiivi	'to climb'

But now notice that if the foregoing is correct, we must posit a new rule which will explain a somewhat different alternation between /v/ and /p/. If an underlying /v/ comes to stand before a consonant through the application of Intersyllabic Vowel Deletion, it will be replaced by /p/. Consider the following future and non-future forms:

(42) <u>Non-future</u>	<u>Future</u>
k <sup>w</sup> iiva	k <sup>w</sup> ipni
heeva	hepni
wiivi	wipni

This v→p rule is completely productive and must be considered a true phonological rule of Hopi. It can be formulated as follows:

(43) Preconsonantal v→p Rule

v→p / \_\_C

Its operation can also be observed in plural forms like [taatapt] 'cottontail' and [cööcöpt] 'deer'. These are

underlyingly /taataavoti/ and /cööcööviti/--they are subject, among other things, to Intersyllabic Vowel Deletion, which results in the [vt] sequences feeding Preconsonantal v→p.

It should perhaps be mentioned here that a characteristic difference between Third and Second Mesa speech is the lack of Preconsonantal v→p in the latter. Thus, Third Mesa [hepni] is Second Mesa [hevni], and so on.

#### 1.7. Final-Vowel Deletion and Pausal Forms

It was mentioned in the context of the discussion of Hopi stress assignment (1.4. above) that certain morphemes which end in consonants in their surface phonological representations apparently do not end in consonants underlyingly. Consider, for example, the common alternant [-t] of the oblique case ending (glossed OBL), as in the following sentence:

(44) Ni? taaqa-t tiwa.

(I man-OBL saw)

'I saw the man.'

There is evidence that this ending is underlyingly /-ta/, rather than /-t/, and that its final vowel is deleted by a rule of roughly the following form:

Final-vowel Deletion Rule

$$V \rightarrow \emptyset / VC\_ \#.$$

The evidence for the posited vowel-final underlying form, and therefore for the deletion rule, comes from the so-called 'pausal' form (cf. Whorf, 1946), which is employed when an element which normally appears in sentence-medial position, as would an object noun phrase, is dislocated to the right so that it appears at the end of the sentence, as in:

(45) Ni? (pit) tiwa, taaqa-t?a.

(I (pit) saw, man-OBL)

'I saw him, the man.'

The pausal form, or one variant of it, to be precise, is formed by inserting a glottal stop immediately before the final vowel; and the latter is executed with considerable stress and on a pitch level somewhat higher than that of the preceding syllable. In this version of the pausal form, the final vowel is, itself, not deleted. (Another variant of the pausal form involves a special intonational effect, but with deletion of the final vowel. The intonational effect consists

in special stress, lengthening, and falling pitch contour--symbolized ^--on the final syllable, i.e. the final syllable of the form which results from Final-vowel Deletion: /ni? (pit) tiwa, taaqât/.)

Since the final vowel which appears in pausal forms is not predictable--and it can be any of the Hopi vowels--we assume tentatively that the vowel is actually present in underlying representation and that the deletion rule is truly a part of Hopi grammar. For some morphemes, there is independent evidence requiring us to postulate an underlying final vowel. The oblique ending, for example, offers independent evidence for the proposal that it ends in /a/ underlyingly--the evidence is the oblique form of the indefinite inanimate singular determiner /hi?ta/ which, for reasons which we do not fully understand, fails to undergo the deletion process. An ending which we might--with historical, but perhaps not synchronic, justification--label the 'augmentative', appearing in such singular nouns as /?iisa-wi/ 'coyote', /hoona-wi/ 'bear', /cööviwi/ 'antelope', etc., is normally pronounced without its final vowel when it appears word-finally; hence, [?iisaw], [hoonaw], [cööviw]. But the reality of this underlying vowel is apparent, for example, in the oblique case, since the oblique ending (whose alternant [-y] is used on these forms) protects the vowel from removal by Final-vowel Deletion. The oblique forms are [?iisawiy], [hoonawiy], and



[cööviiy]. The animate nonsingular number endings--[-m] and [-t] when word-final--as in

- (46) Pima momoya-m niy wiva?tota.  
 (those women-nonsingular me struck)  
 'Those women struck me.'

- (47) Pima ta?taq-t niy wiva?tota.  
 (those men-nonsingular me struck)  
 'Those men struck me.'

are, on the evidence of the pausal forms, underlyingly /-mi/ and /-ti/ respectively:

- (46') Pima niy wiva?tota, momoya-m?i.  
 (those me struck, women-nonsingular)  
 'They struck me, the women.'

- (47') Pima niy wiva?tota, ta?taq?t?i.  
 (those me struck, men-nonsingular)

'They struck me, the men.'

And, again, the oblique forms provide independent evidence in support of the proposed underlying representation:

(48) Ni? momoy-mi-y tiwa.

(I women-nonsingular-OBL saw)

'I saw the women.'

(49) Ni? ta?taq-ti-y tiwa.

(I men-nonsingular-OBL saw)

'I saw the men.'

But for the vast bulk of morphemes which we assume undergo Final-vowel Deletion, only the pausal form gives evidence of a final vowel. And the fact that many morphemes show variation in the quality of the vowel appearing in their pausal forms suggests that a reanalysis might be taking place according to which many elements--like the concessive particle [kir], for example, which has variant pausal forms [kir?a] and [kir?i]--are now underlyingly consonant-final, and according

to which the pausal form is effected by appending /-ʔa/ or /-ʔi/, rather than by merely inserting a glottal stop before an underlying final vowel.

We will not adopt here the alternative just mentioned, however. We will assume that Final-vowel Deletion is a genuine rule of Hopi phonology. But in doing this, we must also recognize that the rule has very special properties. Specifically, it is morphologically conditioned. It applies only to what might be termed minor morphemes. It does not apply, for example, to verbs and to nouns. We list below the classes of morphemes which undergo Final-vowel Deletion, together with representative morphemes in each class both in their normal, or truncated, forms and (parenthetically) in their putatively vowel-final underlying forms:

(50) (a) oblique endings

-t (/ -ta/)

-y (/ -yi/)

(b) nonsingular endings

-m (/ -mi/)

-t (/ -ti/)

(c) conjunctions

-q (/ -qö/) 'obviative'

-t (/ -ti/) 'proximate sequential'

- k<sup>y</sup>aŋ (/ -k<sup>y</sup>aŋ<sup>?</sup>a/) 'proximate simultaneous'
- e<sup>?</sup> (/ -e<sup>?</sup>e/) 'proximate hypothetical'
- qa (/ -qa<sup>?</sup>e/) 'proximate causal'
- (d) possessive endings (third person only, obviative)
- (<sup>?</sup>)at (/ -(<sup>?</sup>)ati/) 'singular possessor'
- (<sup>?</sup>)am (/ -(<sup>?</sup>)ami/) 'nonsingular possessor'
- (e) singular determiners and pronouns
- pam (/pami/) 'that (middistal, demonstrative)'
- mi<sup>?</sup> (/mi<sup>?</sup>i/) 'that (distal, evocative); he, she, it'
- ?i<sup>?</sup> (/?i<sup>?</sup>i/) 'this'
- ni<sup>?</sup> (/ni<sup>?</sup>i/) 'I'
- ?im (/?ima/) 'you (sg)'
- ?iŋ (/?iŋi/) 'you (oblique)'
- hak (/haki/) 'who'
- (f) postpositions
- ?aw (/?awi/) 'dative'
- ?amim (/?amima/) 'comitative'
- ?aŋ (/?aŋa/) 'perlative'
- ?ak<sup>w</sup> (/?ak<sup>w</sup>a/) 'instrumental'
- ?ep (/?epe/) 'locative'
- etc.
- (g) particles
- ?as (/?asa/) 'unachieved intention'
- yaw (/yaw/i/) 'quotative'

tir (/tira/) 'regretably'  
 pas (/pasa/) 'very'  
 sen (/sena/) 'possibly'  
 etc.

(h) "augmentative"

-w (/wi/)

Our putative Final-vowel Deletion Rule, in combination with the Intersyllabic Vowel Deletion Rule (of 1.2. above), accounts for the final consonant clusters in many animate plurals formed with /-ti/:

(51) <u>Singular</u>	<u>Plural</u>	
waakasi	waawakas-t	'cow'
taavo	taatap-t	'cottontail'
koona	kookon-t	'squirrel sp.'
?aani	?aa?an-t	'ant'
maana	maman-t	'girl'
koyonjo	kokoyon-t	'turkey'
pa?k <sup>w</sup> a	paavak <sup>w</sup> -t	'frog'
taaqa	ta?taq-t	'man'
paawik <sup>y</sup> a	paavawik-t	'duck'
?a <sup>w</sup> isi	?a?a <sup>w</sup> is-t	'crow'

We assume that the final clusters in the plurals here arise through the action of the two vowel deletion rules, ordered as in the following illustrative derivation:

(52) /kokoyon<sub>o</sub>-ti/

kokoyon<sub>t</sub>i                    Intersyllabic Vowel Deletion

kokoyon<sub>t</sub>                      Final-vowel Deletion

In closing this discussion, we reemphasize the fact that both vowel deletion processes are morphologically conditioned. That is to say, not all morphemes undergo Final-vowel Deletion--it is not even the case that all suffixes do (for example, the relative clause marker /-qa/ (see 3.1. below), the tense-aspect endings /-ni/ and /-ŋ<sup>w</sup>i/ (see 2.5.2. below), and the plural agreement suffix /-ya/, are prominent exceptions to the process). Nor do all Hopi forms which satisfy the strictly phonological conditions of Intersyllabic Vowel Deletion actually undergo the rule (oblique case forms, for example, regularly fail to undergo that rule--consequently, underlying /koyon<sub>o</sub>-ta/ (turkey-OBL) is surface [koyon<sub>o</sub>t], not \*[koyon<sub>t</sub>], as might otherwise be expected). In short, although a number of important generalizations can be made concerning the applicability of these rules, in the final

analysis, Hopi forms must be specifically marked to undergo them, or not to undergo them, as the case may be.

## CHAPTER 2

## INTRODUCTORY REMARKS ON HOPI MORPHOLOGY AND SYNTAX

2.0. Introduction

The purpose of this chapter is to provide background information which will aid the reader in the understanding of certain topics which will be discussed in detail in Chapters 3 and 4. This orientation will cover a variety of surface phenomena, including the various categories which are overtly marked in Hopi (number, case, and obviation), together with an elementary exposition of Hopi parts of speech and phrase structure.

2.1. The Number Category in Hopi

In this section we are concerned with the phenomenon of number agreement and with the characterization of various morphological mechanisms employed to mark the category of number in various parts of speech.

To introduce the topic, let us consider the following sentences:



- (1) mi? maana paki  
 (that girl enter)  
 'The girl entered.'
- (2) mima maanat paki  
 (those girls enter)  
 'Those girls(dual) entered.'
- (3) mima mamant yin<sup>y</sup>a  
 (those girls entered)  
 'Those girls(plural) entered.'

Obviously there is some kind of noun phrase-verb agreement here, as well as determiner-noun agreement. Furthermore, notice that the parts of speech, namely, verb, determiner, and noun each mark slightly different categories. Thus, the question at hand is this: precisely what are the number categories and how are the various parts of speech (nouns, determiners, and verbs) marked for them?

It is clear from Ss (1)-(3) that nouns (actually, only animate nouns) distinguish three numbers:

- |                     |        |
|---------------------|--------|
| (4) <u>Singular</u> | maana  |
| <u>Dual</u>         | maanat |
| <u>Plural</u>       | mamant |

Let us assume that the number features of Hopi are simply singular (i.e. [sg]) and plural (i.e. [pl]) and that each of the features can have the values plus or minus. This feature system will suffice to distinguish the three numbers found in the Hopi nominal system.

(5)	$\begin{bmatrix} +sg \\ -pl \end{bmatrix}$	maana
	$\begin{bmatrix} -sg \\ -pl \end{bmatrix}$	maanat
	$\begin{bmatrix} -sg \\ +pl \end{bmatrix}$	mamant

Determiners evidently distinguish only two numbers:

(6)	<u>Singular</u>	mi?
	<u>Nonsingular</u>	mima

Using our feature notation, determiners would then be assigned the values,

(7)	[+sg]	mi?
	[-sg]	mima

Notice that the plurality value for the first of these would be [-pl] predictably; the second, however, must be left unspecified for plurality, since /mima/ may be either dual (i.e. [-pl]) or plural (i.e. [+pl]). This feature representation applies as well to the human and general animate interrogative-indefinite determiners:

(8)	<u>Human</u> ('who')	<u>General Animate</u> ('who, what')
	[+sg] hak	himi
	[-sg] hakim	hi?ti(m)

These are given in the 'subject' or 'non-oblique' form--i.e. as they would appear when functioning as the subject of the sentence.

First and second person 'pronouns', like the third person determiners, make a two-way distinction. The full set of pronouns and non-interrogative determiners (in subject form) is presented in the following chart:

(9)	[+sg]			[-sg]	
	1	ni?	'I'	?itam	'we'
	2	?im	'you'	?ima	'you'
	3	pam	'he, she, it, that'	pima	'they, those'
		mi?	'that' (removed, evocative)	mima	'those'
		?i?	'this'	?ima	'these'

(The numerals 1, 2, 3 designate first, second, and third persons.)

Finally, verbs like determiners make a two-way distinction, however, the essential feature is plurality, not singularity:

(10)	<u>Non-plural</u>	paki
	<u>Plural</u>	yin <sup>y</sup> a

These will be assigned the following sentences:

(11)	[-pl]	paki
	[+pl]	yin <sup>y</sup> a

Note here that the singularity feature [+sg] cannot be assigned to /paki/ since that form can also be dual--it must be left unspecified. On the other hand, /yinj<sup>y</sup>a/ is predictably [-sg].

#### 2.1.1.1. The Morphology of Number-Marking in the Nominal System

Having specified in the introduction above what the number categories of Hopi are and having devised a feature representation for them, we are concerned, in this section, with the various morphological devices which Hopi employs in marking number on nouns.

First of all, notice that the singular form of the noun (e.g. /maana/) consists of the base alone, that is to say, it is not overtly marked for singular number. Dual number, for animate nouns only, is marked by means of a suffix [-t] (whose underlying form is /-ti/, see 1.7. above).<sup>1</sup> Thus, for example, we have

(12) maana-t	'girls'	(dual)
taavo-t	'rabbits'	(dual)
ciro-t	'birds'	(dual)
tiyo-t	'boys'	(dual)
taaqa-t	'men'	(dual)

In terms of its morphological manifestations, plurality is the most complex in that there are several devices for forming plurals for nouns. Furthermore, a distinction must be made between animate and inanimate nouns. We deal first with the inanimates.

It was mentioned in 1.3. above that one of the ways in which plurals are formed is by reduplication. Inanimate nouns are quite regular; they form their plurals by reduplication only; thus we have,

(13) <u>Non-plural</u>	<u>Plural</u>	
siri	sisri	'tail'
kiihi	kiikihi	'house'
poyo	popyo	'knife'
tana	tatna	'hoof'
soki	soski	'finger or toenail'
tama	tatma	'teeth'

The inanimate interrogative determiner forms its plural by reduplication alone--hence, non-plural /himi/ and plural /hiihi?mi/.

Animate nouns are more complex. There are four quite regular patterns animate nouns use in forming their plurals.

They are the following:

- (14) (a) the suffix /-mi/  
 (b) reduplication plus the suffix /-mi/  
 (c) reduplication plus the suffix /-ti/  
 (d) lengthening of the final vowel and addition  
 of the suffix /-ti/.

It is not possible to predict which of the four patterns a given noun will conform to, but once it is known to which category it belongs, its plural formation is quite regular. We give now examples of all four categories.

Nouns which form their plural by pattern (3a) take a suffix /-mi/, which in word-final position appears as [-m], due to the operation of the final vowel deletion described in 1.7. above. Thus, for example,

(15) <u>Singular</u>	<u>Plural</u>	
kawayo	kawayo-m	'horse'
kacina	kacina-m	'kachina'
kaneélo	kaneélo-m	'sheep'
mácaak <sup>w</sup> a	mácaak <sup>w</sup> a-m	'frog'

kowaáko	kowaáko-m	'chicken'
sino	sino-m	'people'
pahaána	pahaána-m	'white man'
tasavi	tasavi-m	'Navajo'

Kinship terms regularly take the /-mi/ suffix in forming their plurals. For example:

(16) <u>Singular</u>	<u>Plural</u>	
?i-ti	?i-ti-m	'my-child'
?i-so	?i-so-m	'my-grandmother'
?i-k <sup>y</sup> a	?i-k <sup>y</sup> a-m	'my-aunt'
?i-k <sup>w</sup> a	?i-k <sup>w</sup> a-m	'my-grandfather'

Nominals, both relative clauses and lexical nominals, formed with the suffix /-qa/ also take /-mi/. In this use, however, the suffix marks non-singular number rather than specifically plural. Thus, for example,

(17) (a)	mima	maanat	yi?a?ata-qa-m
	(those girls(dual))	speak-qa-mi)	
	'those girls(dual) who are speaking'		



- (b) mima mamant yi?a?atota-qa-m  
 (those girls(plural) speak(plural)-qa-m)  
 'those girls(plural) who are speaking'

The suffix /-mi/ with this more general [-sg] force is also used in the formation of non-singular pronouns and determiners--see introduction to this section for actual forms. Unaccountably, however, the final /i/ of this suffix is replaced by /a/ in the non-singular subject forms built on monosyllabic determiner bases--e.g. /pima, mima, ?ima/. The non-singular general animate interrogative is irregular in its non-singular form, which apparently involves the suffix /-ti/ optionally extended by /-mi/--i.e. [hi?ti(m)].

Examples of nouns which form their plurals in accordance with (3b) are the following:

(18) <u>Singular</u>	<u>Plural</u>	
mooro	moomoro-m	'burro'
moola	moomola-m	'mule'
caayo	caacayo-m	'child'

To this pattern should be added the diminutive element /-hoya/ which appears as a suffix to nouns. Diminutive plurals exhibit reduplication of the noun stem together with pluralization--according to pattern (3b)--of the suffix. Thus, the plural of /mana-hoya/ [manawya] 'little girl' is /mamana-hoohoya-mi/ [mamanho<sup>?</sup>yam].

Nouns of type (3b) are relatively rare, as are those of the next class to be considered--i.e. (3d), those forming their plurals by lengthening their final vowels and adding the /-ti/ suffix:

(19) <u>Singular</u>	<u>Plural</u>	
momo	momoo-t	'bee'
ciro	ciroo-t	'bird'
sowi	sowii-t	'jackrabbit'
tik <sup>y</sup> a	tik <sup>y</sup> aa-t	'prairie dog'
?a?a	?a?aa-t	'magpie'

The next pattern to be considered--i.e. (3c)--is by far the most productive. That is, nouns that form plurals by reduplication and addition of the suffix /-ti/ are numerous. Thus, for example,

(20) <u>Singular</u>	<u>Plural</u>	
moŋ <sup>w</sup> i	momŋ <sup>w</sup> i-t	'owl'
moŋ <sup>w</sup> i	momŋ <sup>w</sup> i-t	'chief'
k <sup>w</sup> aayo	k <sup>w</sup> aak <sup>w</sup> ay-t	'eagle'
?aani	?aa?an-t	'ant'
taavo	taatap-t	'rabbit'
koyoyŋ	kokoyŋ-t	'turkey'
?aŋ <sup>w</sup> isi	?a?aŋ <sup>w</sup> is-t	'crow'
laqana	lalaqan-t	'squirrel'
tokoci	totokoc-t	'bobcat'
po?ko	popko-t	'dog'
maana	maman-t	'girl'

The last two, that is [popko-t] and [maman-t], are slightly irregular in that the reduplication--itself irregular--is applied to a stem which differs, albeit minutely, from the singular: /poko/ and /mana/.

The following class of nouns also exemplify pattern

(3c):

(21) <u>Singular</u>	<u>Plural</u>	
cööviv	cööcöp-t	'deer'
?iisaw	?ii?is-t	'coyote'
hoonaw	hoohon-t	'bear'

As pointed out in 1.7. above, the singulars of these nouns end in the "augmentative" suffix; this regularly drops in the plural. Thus, the plural of [cööviw] is based on /cöövi/ and [ʔiisaw] on /ʔiisa/. This augmentative is not omitted in the dual--thus, /cöövi-wi-ti/ [cööviwt]; /ʔiisa-wi-ti/ [ʔiisawt].

This concludes our discussion of the major patterns of plural formation in nouns. There are, however, several nouns whose plurals must, synchronically at least, be considered irregular. These include the following:

(22) <u>Singular</u>	<u>Plural</u>	
tiyo	tooti-m	'boy'
wiʔti	momoya-m	'woman'

The first of these evidently involves reduplication together with the /-mi/ suffix; however, the reduplication does not conform to any known pattern. The second apparently involves a suppletive stem, perhaps /moya/, which is itself reduplicated and extended by the suffix /-mi/. There also exists a regular plural based on the noun /wiʔti/--to wit, /wiiwiʔti-mi/ [wiiwiʔtim].

### 2.1.2. The Morphology of Number Marking in the Verbal System

All verbs agree with their subjects in plurality. This is true of all verbs. However, the overt marking of the plural category varies considerably. There are five principle morphological devices involved in marking the plural/nonplural distinction in verbs:

- (23) (a) the suffix /-ya/  
 (b) suppletion  
 (c) reduplication  
 (d) the infix /-to-/  
 (e) suffixal suppletion

The first of these is reasonably common and morphologically completely transparent. It is exemplified by the following:

(24) <u>Non-plural</u>	<u>Plural</u>	
piin <sup>y</sup> a	piin <sup>y</sup> a-ya	'to break-as glass'
peena	peena-ya	'to write'

paʔaŋ <sup>w</sup> a	paʔaŋ <sup>w</sup> a-ya	'to assist'
tiʔi	tiʔi-ya	'to buy'
hoona	hoona-ya	'to send away'
maqa	maqa-ya	'to give'
tiiva	tiiva-ya	'to discard'
maspa	maspa-ya	'to throw away'
yooha	yooha-ya	'to break'
ʔaasi	ʔas-ya	'to play'
hohonaqa	hohonaq-ya	'to play'
momori	momor-ya	'to swim'
haawi	haw-ya	'to go down'
ʔaama	ʔam-ya	'to bury'
waʔö	waʔök-ya	'to lie, recline'
mini	minik-ya	'to fall'
tönö	tönök-ya	'to stumble or trip'
hoyo	hoyok-ya	'to move'

As can be seen from the examples cited, some verbs undergo truncation (cf. section 1.2. above) while others merely add the suffix without other phonological effect. Still other verbs--which we refer to as "k-verbs"--regularly exhibit an increment /-k-/ before suffixes, including the plural /-ya/.

All verbs formed with the causative suffix /-na/ form their plurals according to pattern (1a). For example:

(25) <u>Non-plural</u>	<u>Plural</u>	
nopna	nopna-ya	'to make eat'
?asna	?asna-ya	'to wash hair'
minikna	minikna-ya	'to cause to fall'
wa?ökna	wa?ökna-ya	'to make lie down'

A large number of Hopi verbs occur in suppletive pairs. That is to say, the plural and the non-plural are entirely distinct stems. Thus, for example,

(26) <u>Non-plural</u>	<u>Plural</u>	
paki	yin <sup>y</sup> a	'to enter'
mooki	so?a	'to die'
püiwi	took <sup>y</sup> a	'to sleep'
wari	yi?ti	'to run'
yama	nöna	'to exit'
wini	hoon <sup>y</sup> a	'to stand'
po?si	löhö	'to fall'
piti	?öki	'to arrive'
tiimoyta	noonova	'to eat'
qati	yeese	'to sit'
wiivi	yayva	'to climb'

A small number of verbs indicate plural number by means of reduplication:

(27) <u>Non-plural</u>	<u>Plural</u>	
tíwa	titwa	'to see'
qöya	qöqya	'to kill (plural object)'
ḡöyva	ḡööḡöyva	'to chase after'

There are two sets of verbs that take the /-to/ infix. Verb themes which consist of a root plus the derivational affix /-ti/ form their plurals by inserting /-to-/ between the root and the ending. Thus, for example,

(28) <u>Non-plural</u>	<u>Plural</u>	
co?omti	co?om-to-ti	'to jump'
tayati	taya-to-ti	'to laugh'
tiitiyti	tiitiy-to-ti	'to be sick'
papti	pap-to-ti	'to have one's turn'

Similarly, verb themes which consist of a root element plus



the derivational suffix /-ta/ also form their plurals by inserting /-to/; thus,

(29) <u>Non-plural</u>	<u>Plural</u>	
yi?a?ata	yi?a?a-to-ta	'to speak'
ta?pamta	ta?pam-to-ta	'to pound'
tiivahomta	tiivahom-to-ta	'to wash'
?ayata	?aya-to-ta	'to hire'
titapta	titap-to-ta	'to instruct, give an order'
kita	ki-to-ta	'to say'
pikta	pik-to-ta	'to make piki'
kiita	kii-to-ta	'to build a house'
tiwita	tiwi-to-ta	'to get ini- tiated'
peeta	pee-to-ta	'to save (as food)'

In addition to the /-ta/ suffix appearing in the verbs of (29), there is a distinct element of the same shape which enters into the more complex derivational endings /-?y-ta/ and /-iw-ta/. This second /-ta/ element is the non-plural member of a suppletive pair, the plural member of which is /-yiŋ<sup>w</sup>a/. Examples are given in (30) below:

(30)	<u>Non-plural</u>	<u>Plural</u>	
	tiwi?y-ta	tiwi?y-yiŋ <sup>w</sup> a	'to know'
	timala?y-ta	timala?y-yiŋ <sup>w</sup> a	'to work'
	tinatya?y-ta	tinatya?y-yiŋ <sup>w</sup> a	'to have a project'
	haqni?y-ta	haqni?y-yiŋ <sup>w</sup> a	'to long for'
	tiŋla?y-ta	tiŋla?y-yiŋ <sup>w</sup> a	'to beg (intr)'
	wa?ökiw-ta	wa?ökiw-yiŋ <sup>w</sup> a	'to lie down'
	maŋi?iw-ta	maŋi?iw-yiŋ <sup>w</sup> a	'to be tired'
	mikiw-ta	mikiw-yiŋ <sup>w</sup> a	'to be warm'
	ta?kikiw-ta	ta?kikiw-yiŋ <sup>w</sup> a	'to be leaning (on something)'

Suffixal suppletion is also illustrated by the following sets:

(31)	<u>Non-plural</u>	<u>Plural</u>	
(a)	maq-to	maq-wisa	'to go hunt'
	hep-to	hep-wisa	'to go seek'
	ti?i-to	ti?i-wisa	'to go buy'
	cam-to	cam-wisa	'to pick up a group of people'
	momor-to	momor-wisa	'to go swim'
	hohonaq-to	hohonaq-wisa	'to go play'
(b)	ŋiy?-ma	ŋiy?-wisa	'to lead'

taw-ma	taw-wisa	'to sing'
yi?a?ati-ma	yi?a?ati-wisa	'to walk along talking'

In this case the two distinct non-plural derivational suffixes --/-to/ 'to go and VERB' and /-ma/ 'to VERB while going along'--are paired suppletively with a single plural partner /-wisa/.

The non-plural derivational ending /-lawi/ is paired with plural /-lalwa/. This is only partially suppletive, however, since simple reduplication could relate the plural to the non-plural, were it not for the disparity observed in the final vowel. Thus, for example,

(32)	<u>Non-plural</u>	<u>Plural</u>	
	pas-lawi	tas-lalwa	'to hoe'
	taw-lawi	taw-lalwa	'to sing'
	pak-lawi	pak-lalwa	'to cry'
	?iy-lawi	?iy-lalwa	'to plant'

Some verbs consist of combinations involving a suppletive stem together with a suppletive suffix. The number dis-

inction in these verbs is represented by suppletion of both the stem and ending:

(33) <u>Non-plural</u>	<u>Plural</u>
warikiwta	yiʔtikiwiŋ <sup>w</sup> a
warikto	yiʔtikwisa
piwto	tokwisa
yamakto	nöŋakwisa

For some speakers, suppletive verbs whose plural member is a k-verb (see (24) above) permit optional use of the suffix /-ya/ in combination with the plural stem:

(34) <u>Non-Plural</u>	<u>Plural</u>
wari	yiʔtikya
poʔsi	löhökya
yama	nöŋakya

Thus, here, as in (33), plural number is doubly marked.

### 2.1.3. Object Agreement

The immediately preceding section deals exclusively with plural/non-plural number agreement between the verb and the subject of the sentence. There also exist transitive verbs which exhibit number agreement with their objects in addition to the subject agreement described above. These facts for one such verb are illustrated in the following Ss:

(35) ni? taavo-t niina

(I rabbit-OBL kill)

'I killed a rabbit.'

(36) ?itam taavo-t niina-ya

(We rabbit-OBL kill-NSG)

'We killed a rabbit.'

(37) ni? taatapti-y qöya

(I rabbit(NSG)-OBL kill)

'I killed rabbits.'

- (38) ?itam taatapti-y qöqya  
 (We rabbit(NSG)-OBL kill(NSG))  
 'We killed rabbits.'

(In the glosses, OBL represents the oblique ending regularly attached to object NP's in Hopi (see 2.2. below for a discussion of case).) Or, given in a paradigm, the facts concerning this verb appear as follows:

		<u>OBJECT</u>	
		<u>Singular</u> (e.g. taavot)	<u>Plural</u> (e.g. taataptiy)
<u>SUBJECT</u>	{ <u>Singular</u> (e.g. ni?)	niina	qöya
	<u>Plural</u> (e.g. ?itam)	niina-ya	qöqya

Object agreement is typically indicated by means of suppletion. Another suppletive pair, [tavi]/[?oyal], is illustrated in the following Ss:

(39) ni? caqapta-t kolci-t       ?ep tavi  
 (I dish-OBL cupboard-OBL on place)  
 'I put the dish on the cupboard.'

(40) ni? cacqapta-t kolci-t       ?ep ?oya  
 (I dish(NSG)-OBL cupboard-OBL on place)  
 'I put the dishes on the cupboard.'

Causative verbs built upon suppletive intransitives must be mentioned here, since the number category of the object of such a causative verb is reflected therein. Thus, for example,

(41) caqapta po?si  
 (dish fall)  
 'The dish fell.'

(42) ni? caqapta-t pos-na  
 (I dish-OBL drop-CAUS)  
 'I dropped (caused to fall) the dish.'

(43) cacqapta löhö  
 (dish(NSG) fall)  
 'The dishes fell.'

(44) ni? cacqapta-t löhök-na  
 (I dish(NSG)-OBL drop-CAUS)  
 'I dropped (caused to fall) the dishes.'

Transitive verbs which involve the complex derivational ending /-?y-ta/ and which can take animate objects, mark the number of the object with the nonsingular element /-mi-/, inserted before the ending. This is illustrated in the following Ss:

(45) ni? mi-t tiyo?ya-t tiwi?yta  
 (I that-OBL boy-OBL know)  
 'I know that boy.'

(46) ni? mimi-y totimhoymi-y tiwi-mi-?y-ta  
 (I those-OBL boy(NSG)-OBL know-NSG-?y-ta)  
 'I know those boys.'



Kin terms appear with the same verb-forming derivational ending. The verbs so formed also mark plural objects with the nonsingular /-mi-/ in the same way. Thus, for example:

(47) ni? ?it yi-?y-ta

(I her mother-?y-ta)

'I have her for a mother.'

(48) ni? ?imiy yi-mi-?y-ta

(I them mother-NSG-?y-ta)

'I have them for mothers (i.e. clan mothers).'

Certain causative verbs formed on intransitive "k-verbs" show plural object agreement by replacing the k-increment with an element /-m-/. Thus, compare the following two sentences:

(49) (a) ni? po?k<sup>y</sup>aya-t wa?ö-k-na

(I po?k<sup>y</sup>aya-OBL lie-k-CAUS)

'I made Po?k<sup>y</sup>aya lie down.'

- (b) ni? caacak-mi-y wa?ö-m-na  
 (I kids-NSG-OBL lie-m-na)  
 'I made the kids lie down.'

Postpositions like transitive verbs, take objects. Moreover, they mark nonsingular number for animate objects. This category is marked by means of the element /-mi-/, inserted between the prefix and the stem of the postposition. For example,

- (50) ni? ?i-t maana-t ?a-mim timala?yta  
 (I this-OBL girl-OBL 3 P -with work)  
 'I work with this girl.'

- (51) ni? ?imi-y maana-ti-y ?a-mim timala?yta  
 (I these-OBL girl-DUAL-OBL 3 P -with work)  
 'I work with these (dual) girls.'

- (52) ni? ?imi-y mamanti-y ?a-mi-mim timala?yta  
 (I these girl(NSG)-OBL 3 P -NSG-with work)  
 'I work with these girls.'

Notice that the element /-mi-/ does not appear with dual, only with plural, objects. (For further details on postpositions, see 2.4. below.)

#### 2.1.4. Rules of Agreement

Certain basic facts of number agreement have now been presented. We have not as yet suggested how the phenomenon of agreement should be handled in the grammar of Hopi, nor will we do so at this stage. Our conception of the proper way in which to account for Hopi number agreement requires as a prerequisite, a theory of phrase structure, which will be delayed until very near the end of this work. However, a few anticipatory remarks seem appropriate at this point.

We will assume that the category of number is assigned to the relevant parts of speech in the base. Thus, for example, animate nouns will be entered in the lexicon in their singular, dual, and plural forms. Each of the nominals will have associated with it the appropriate feature representation. For example,

(53) taaqa	$\begin{bmatrix} +sg \\ -pl \end{bmatrix}$
taaqaat	$\begin{bmatrix} -sg \\ -pl \end{bmatrix}$

taʔtaqt

$$\begin{bmatrix} -sg \\ +pl \end{bmatrix}$$

Similarly, for the other part of speech.

The rules of the base will generate structures in which elements marked for number are "in construction with" one another. Some of these will be well-formed, as in the verb phrase

taavo-t          niina  
(cottontail-OBL kill)

with singular object and non-plural verb, and some will be ill-formed, as in the verb phrase

\*taatapti-y      niina  
(cottontail-OBL kill)

with a plural object and a non-plural verb.

Rules of agreement, we will assume, are simply condi-

tions on well-formedness which filter out cases in which elements in construction with one another exhibit conflicting number marking--i.e. where such elements disagree in the value assigned to a particular number feature, as in the ill-formed object-verb combination above.

The problem will be to characterize precisely, and as generally as possible, the notion "in construction with" so that the agreement rule operates correctly in comparing elements marked for the number categories. This, in turn, will depend upon an adequate theory of phrase structure.

#### 2.2.0. Case Marking

In the following subsections, we will briefly discuss the oblique case marking appearing on nouns (2.2.1.) and determiners (2.2.2.).

##### 2.2.1. Nouns

The grammatical function of nominals in Hopi sentences is signaled in part by the presence or absence of an ending which we will refer to as the "oblique case" (glossed OBL in illustrative Ss). Speaking in very general terms, a nominal functioning as subject is uninflected for case, while a nominal not functioning as subject is marked for oblique case. In structural terms, we can say a NP immediately dominated by a S-node is uninflected while a NP dominated by any other node

is inflected. The latter circumstance includes the following:

- (54) (a) a NP functioning as the object of a verb,  
i.e. under VP,
- (b) a NP functioning as the object of a post-  
position, i.e. under the node PP,
- (c) a NP functioning as possessor, i.e. under the  
node NP.

These are exemplified in the sentences of (55) below, given in tree-form using conventional labels for categorial nodes:

(55) (a)

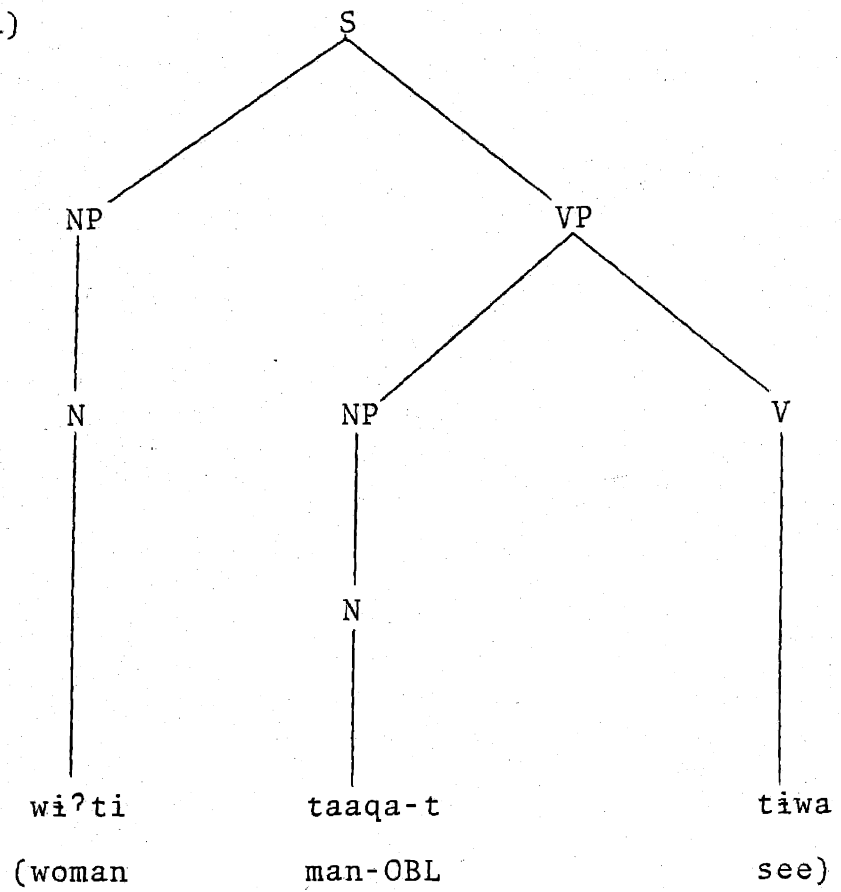

'The woman saw the man.'

(b)

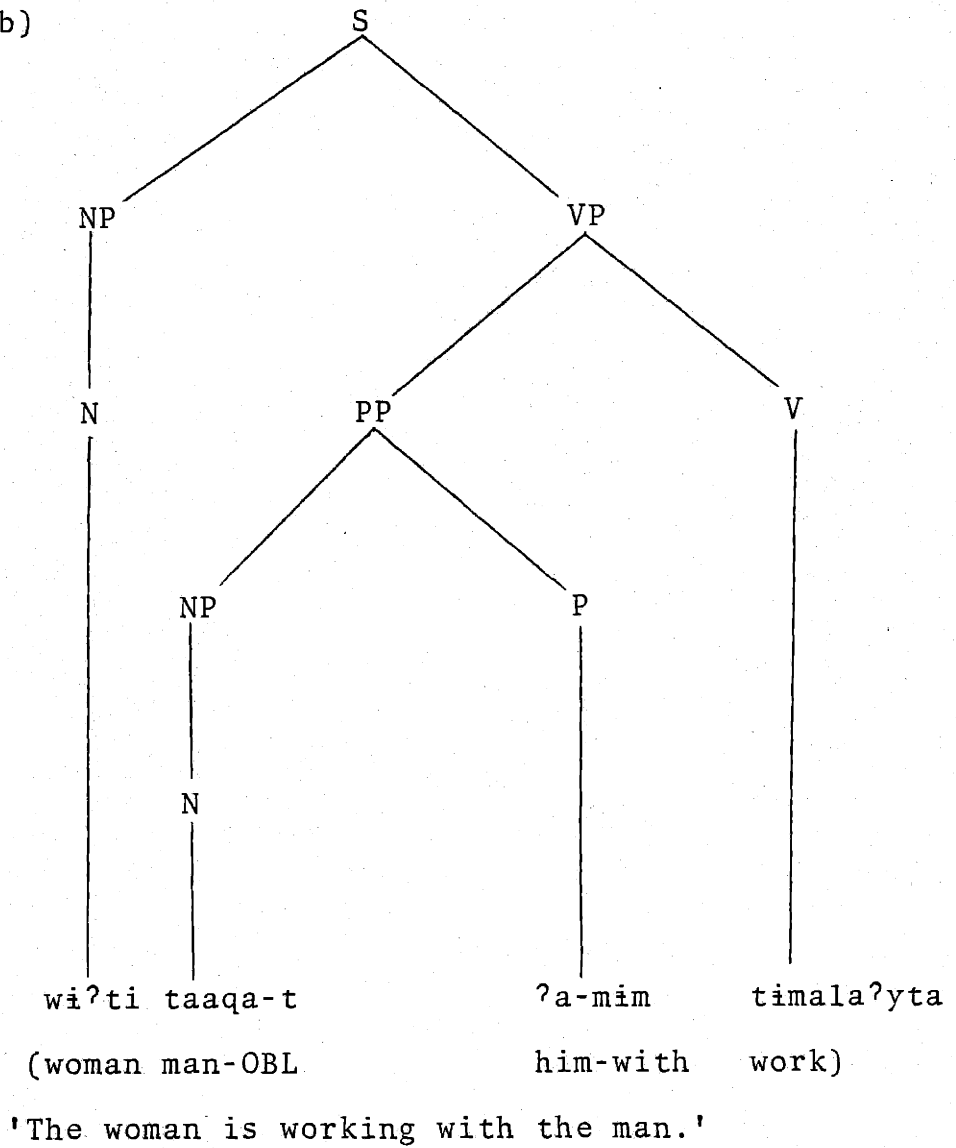



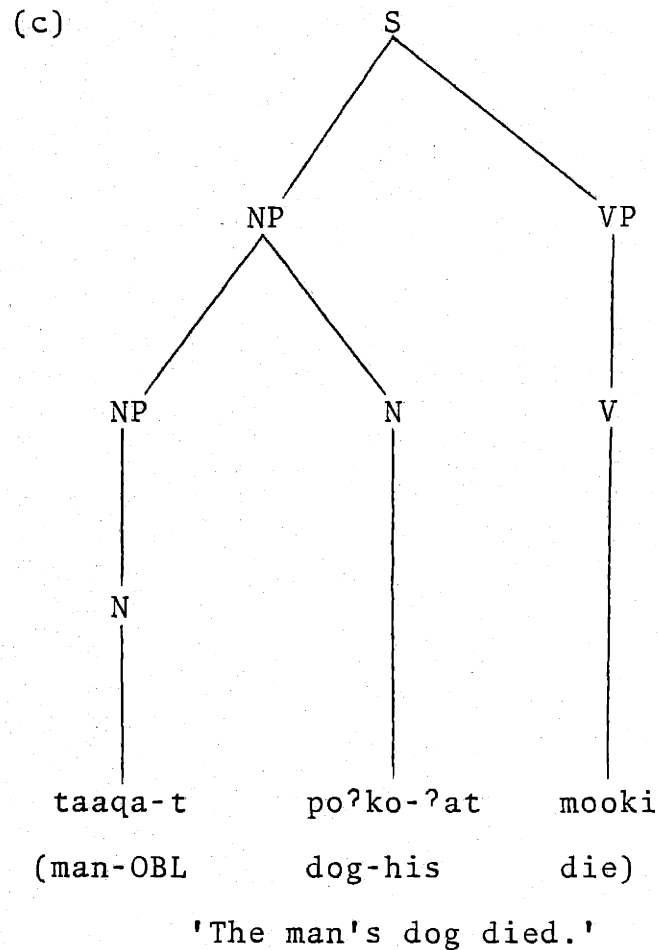

Notice that in each of these sentences the noun /taaqa/ 'man' is inflected for oblique case by means of the suffix /-ta/ (surface [-t], see 1.7. above). This follows from the fact that it is, in each of these sentences, the head (i.e. nucleus) of a NP immediately dominated by a node other than S. By contrast, the nouns /wi?ti/ and /po?ko/ lack the oblique suffix-- in other words, they are uninflected for case--following from the fact that they are the heads of noun phrases immediately

dominated by the S-node. (The element [-ʔat] appearing on the possessed noun here is explained in the section on the possessive construction below.)

Our concern in this section is primarily with the morphology of the oblique case in combination with nouns, pronouns, and determiners. We exclude from this section certain details of case marking which are better left to later portions of the work--see Chapter 3 below.

The oblique ending has two alternants, /-ta/ and /-yi/, which we will refer to in their more common form, that is surface [-t] and [-y] respectively (see 1.7. above).

The alternant [-y] appears on

- (56) (a) nonsingular animate nouns,
- (b) nouns ending in the augmentative suffix  
          /-wi/ [-w],
- (c) possessed nouns.

These are exemplified in the following paradigms:

(57)	<u>Non-Oblique</u>		<u>Oblique</u>		
(a)	<u>Dual</u>	<u>Plural</u>	<u>Dual</u>	<u>Plural</u>	
	poʔkot	popkot	poʔkoti-y	popkoti-y	'dog'
	maanat	mamant	maanati-y	mamanti-y	'girl'
	<u>Non-Oblique</u>		<u>Oblique</u>		
(b)	?iisaw		?iisawi-y		'coyote'
	hoonaw		hoonawi-y		'bear'
	cööviw		cööviwi-y		'deer'
	miiyaw		miiyaw-i-y		'moon'
	?oomaw		?oomawi-y		'cloud'
(c)	?i-tipko		?i-tipko-y		'my brother'
	?i-tipko-m		?i-tipko-mi-y		'my brothers'
	?iʔ-tipko		?iʔ-tipko-y		'your brother'
	?iʔ-tipko-m		?iʔ-tipko-mi-y		'your brothers'
	?itaʔ-tipko		?itaʔ-tipko-y		'our brother'
	?itaʔ-tipko-m		?itaʔ-tipko-mi-y		'our brothers'
	?imiʔ-tipko		?imiʔ-tipko-y		'your(NSG) brother'
	?imiʔ-tipko-m		?imiʔ-tipko-mi-y		'your(NSG) brothers'
	tipko-ʔat		tipko-y-at		'his brother'
	tipko-m-at		tipko-mi-y-ati-y		'his/their brothers'
	tipko-ʔam		tipko-y-ami-y		'their brother'

Notice that in the third person possessed nouns, [-y] appears before the possessive suffix, and in the last two forms, after it as well.

The alternant [-t] appears elsewhere. That is to say, it appears on

- (58) (a) singular, unpossessed nouns,  
 (b) inanimate plural nouns.

These cases are exemplified in the following paradigms:

(59)	<u>Non-Oblique</u>	<u>Oblique</u>	
(a)	poʔko	poʔko-t	'dog'
	maana	maana-t	'girl'
	taaqa	taaqa-t	'man'
	wiʔti	wiʔti-t	'woman'
	k <sup>w</sup> asa	k <sup>w</sup> asa-t	'dress'
	caqapta	caqapta-t	'dish'
(b)	cacqapta	cacqapta-t	'dishes'
	k <sup>w</sup> aksa	k <sup>w</sup> aksa-t	'dresses'
	paavasa	paavasa-t	'fields'

### 2.2.2. Pronouns and Determiners

There is a certain amount of irregularity in the morphology of the oblique case in pronouns. The entire set of pronouns and definite determiners in the oblique form appears as follows:

(60)	<u>Singular</u>	<u>Nonsingular</u>
1	ni-y	?ita-mi-y
2	?iŋ	?i-mi-y
3	pit	pi-mi-y
	?i-t	?i-mi-y
	mi-t	mi-mi-y

(The non-oblique forms are given in 2.1.0. above.) From the above it can be seen that nonsingular pronouns exhibit the [-y] alternant, as expected; however, the [-y] variant also appears on 1st person singular form--i.e. [niy]. Furthermore, the second person singular is unaccountably [?iŋ]. Third person singular pronoun/determiners, again, as expected, exhibit the [-t] alternant.

The oblique forms of the interrogative indefinite determiners are displayed in the following chart:

(61)	<u>Interrogative-Indefinite Determiners</u>	
	<u>Singular</u>	<u>Plural</u>
human	haki-y	haki-mi-y (~haahaki-mi-y)
general animate	hi <sup>?</sup> -ta	hi <sup>?</sup> ti-(mi)-y (~hiihi <sup>?</sup> ti-(mi)-y)
inanimate	hi <sup>?</sup> -ta	hiihi <sup>?</sup> -ta

One slight irregularity consists in the fact that the human singular is [haki-y] (one would expect \*[haki-t]). The final /a/ in /hi<sup>?</sup>-ta/ and /hiihi<sup>?</sup>-ta/ is the underlying final vowel of the oblique ending (see 1.7.).

The principle for the use of oblique and non-oblique forms of pronouns and determiners is identical to the principle articulated above in relation to nouns. Thus, a determiner or pronoun belonging to a NP immediately dominated by S will appear in non-oblique form, otherwise it will appear in the oblique form. A determiner may or may not be accompanied by a head noun. If it is, then the two constituents will exhibit Case Concord (to be discussed in a later chapter) in conformity with these principles. For example, the determiner and noun are in the non-oblique case in the subject NP of (62a) while both are in the oblique form in the object NP of (62b):

(62) (a)

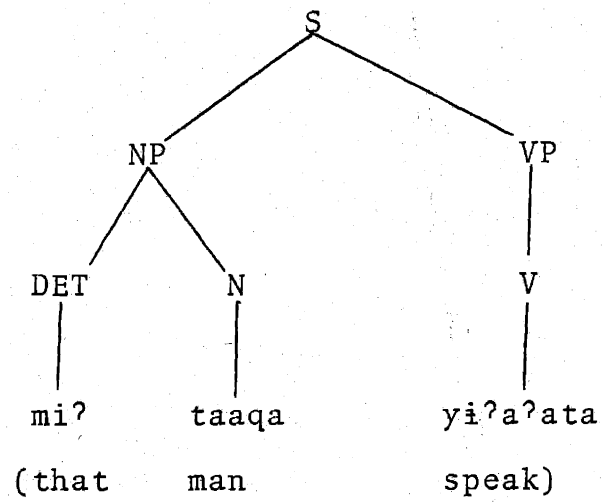

'That man is speaking.'

(b)

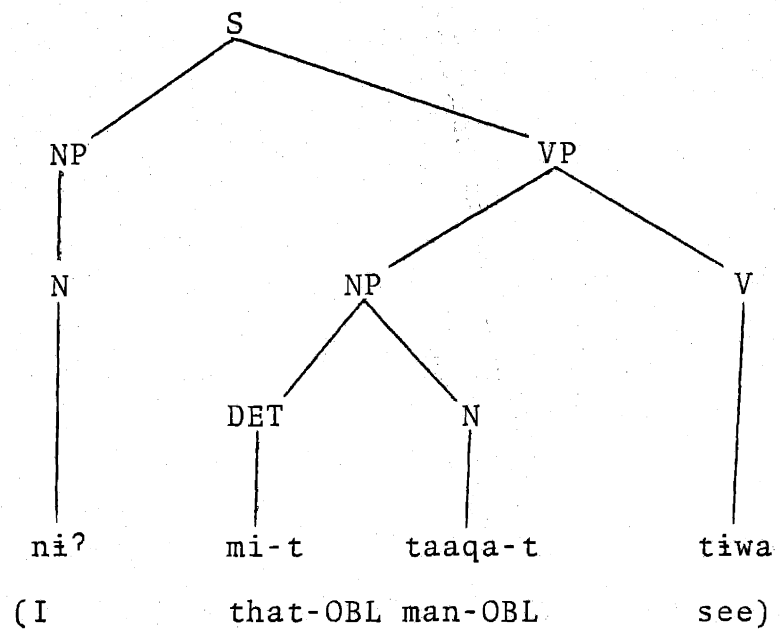

'I saw that man.'

In this discussion, we have expressed the principle of case assignment in terms of immediate domination. This is sufficient for the examples we have at hand here. However, this is only an approximation and will require refinement in a later chapter.

### 2.3.0. The Possessive Construction

As we implied in the tree configuration (55c) in section 2.2.0. above, we assume that the possessive constructions in which a full noun phrase functions as possessor is a complement-head structure identical in nature to other complement-head structures in Hopi--i.e. the transitive verb phrase and the postpositional phrase. That is to say, a noun phrase functioning as a possessor appears as a left sister of the head noun in a larger structure which is itself a NP:

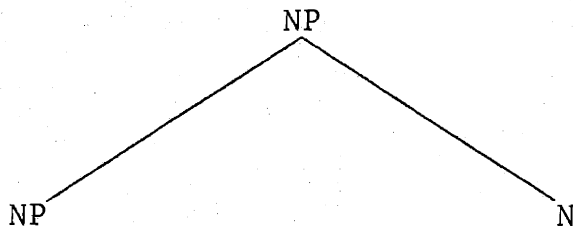

In accordance with the principle of case assignment, the possessor NP is marked for oblique case. This configuration we



will assume is appropriate for possessive constructions like,

- (63) mi-t        taaqa-t poʔko-ʔat  
       (that-OBL man-OBL dog-POSS)  
       'that man's dog'

as in the S,

- (64) mi-t        taaqa-t poʔko-ʔat mooki  
       (that-OBL man-OBL dog-POSS die)  
       'that man's dog died'

with the phrase marker,

(64')

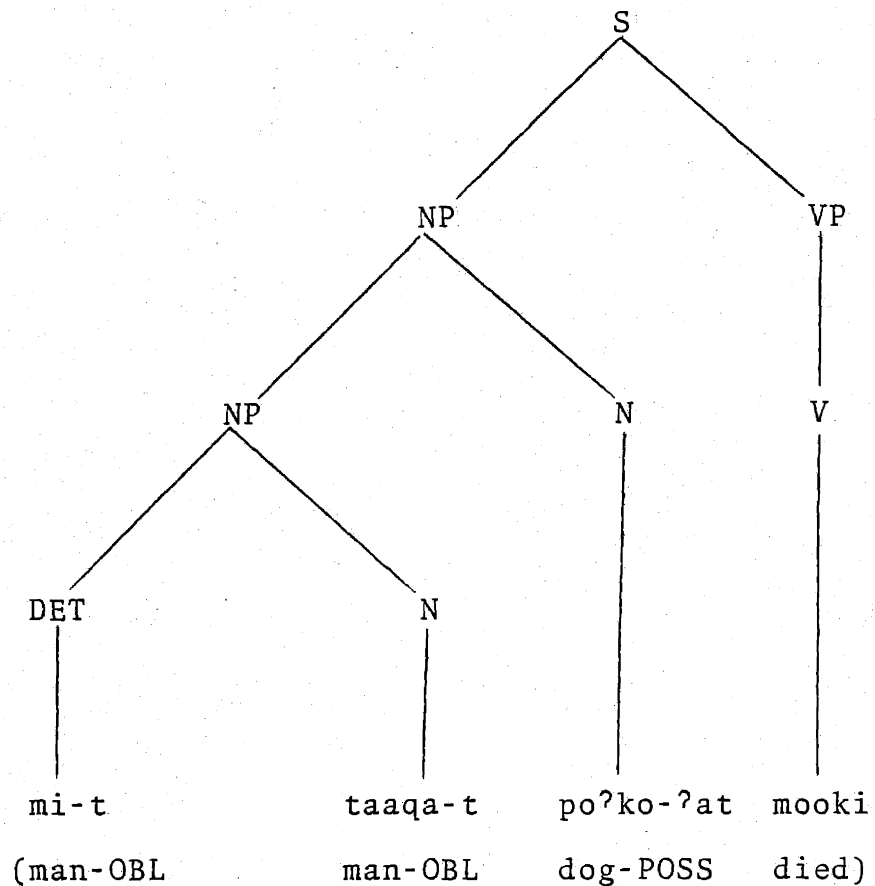

There are possessive construction for which this configuration is not appropriate--at least not at the surface representations of sentences. This second type consists of two subcases: (a) possessive constructions in which the possessor is 1st or 2nd person and (b) possessive constructions in which a third person possessor is understood to be coreferential with the subject of the sentence. In neither of these cases is the possessor represented by an overt NP. We will assume for the time being that the configurations embodied

in the following example sentences are appropriate for possessive constructions of this second type.

(65) (a)

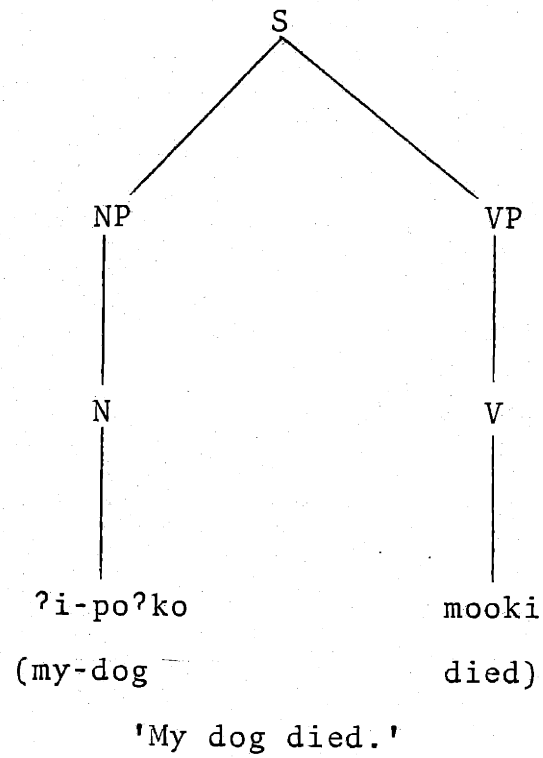

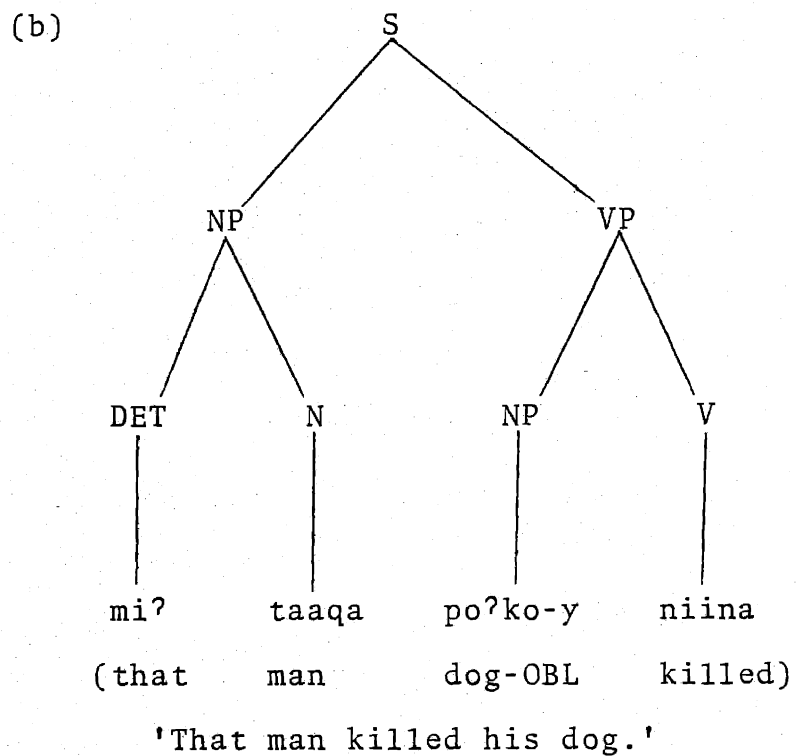

In (65b) above, there is no direct evidence in the structural configuration that the object NP is possessed. In fact, the structure given is exactly that assumed for a simple transitive sentence like,

(66)

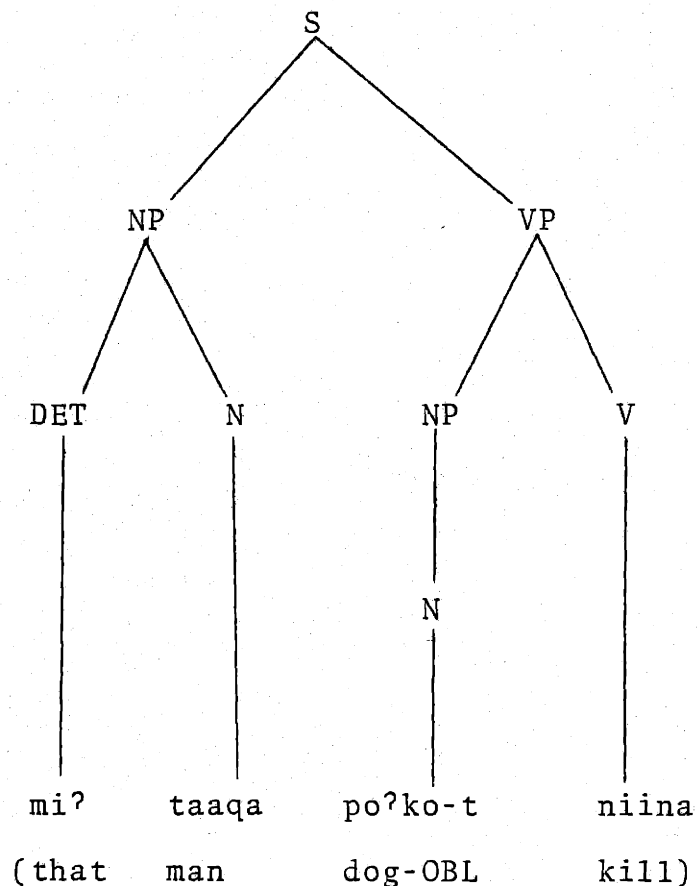

However, (66) translates simply 'The man killed the dog', whereas (65b) has the possessive reading 'The man killed his (own) dog'. The appearance of the y-alternant of the oblique ending in (65b) indicates clearly that the noun is possessed--see the section on case marking above. Sentence (65b), then, contrasts minimally with sentence (66) in which the t-alternant of the oblique ending appears.

Let us now contrast (65b) with a similar sentence in which the possessor is not coreferential with the subject of

the sentence:

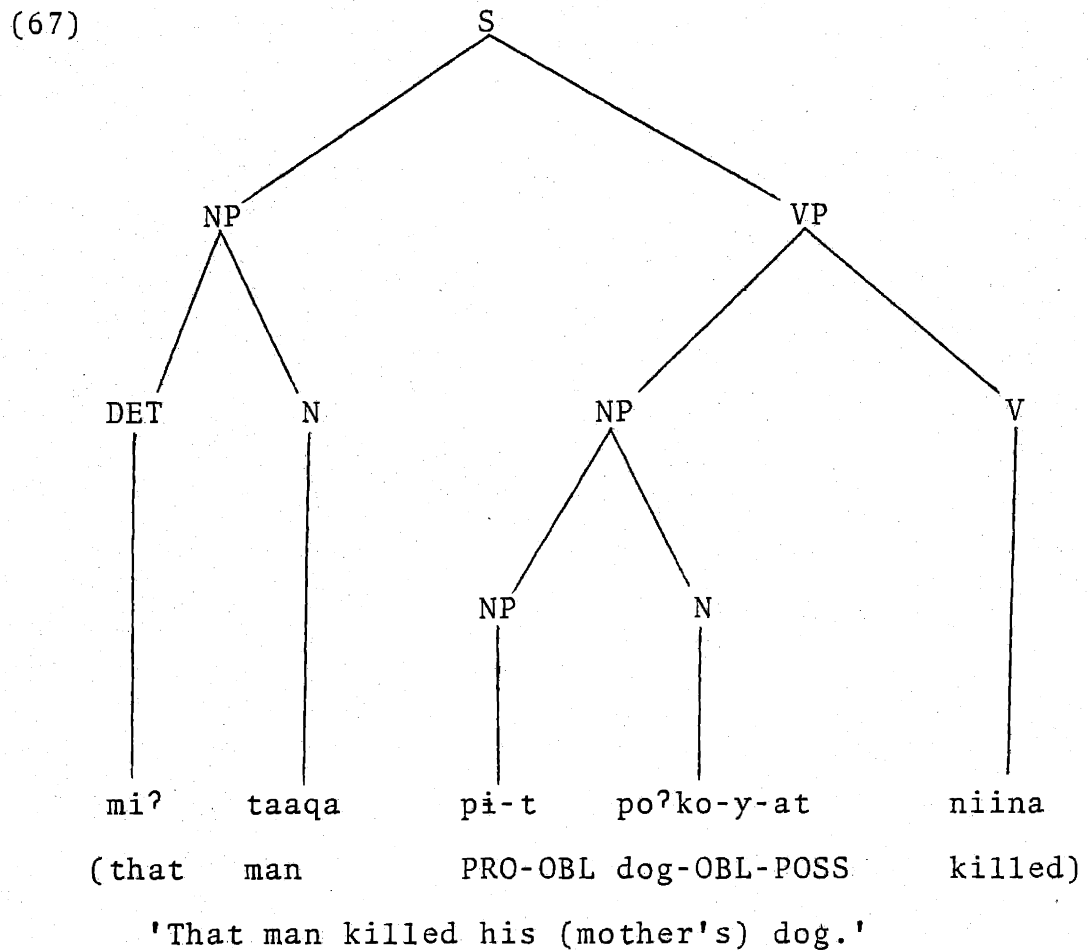

Notice that here, by contrast with (65b), an overt possessed noun phrase is allowed to appear as left sister to the head noun. We have chosen to exemplify this with a pronoun (which we assume belongs to the determiner part of speech but which will be glossed PRO), in order to illustrate the fact that if

this pronoun deletes, as it may freely do, the resulting sentence is still distinct from (65b); reproduced here as (68b):

(68) (a) mi? taaqa po?ko-y-at niina.

'That man<sub>i</sub> killed his<sub>j</sub> dog.'

(b) mi? taaqa po?ko-y niina.

'That man<sub>i</sub> killed his<sub>i</sub> dog.'

As the subscripts in the translations indicate, (68a) marks non-coreference between the subject and the possessor, while (68b) marks coreference between them. This is one of a number of instances in Hopi grammar in which the phenomenon of 'obviation' (cf. Voegelin and Voegelin, 1975) is marked. Briefly, obviation concerns coreference relations between the subject of a sentence and some noun phrase within the sentence. The term subsumes the opposed concepts obviative (the non-coreference case) and proximate (the coreference case). Thus, sentence (68a) illustrates obviative possession--overtly marked by means of the suffix /-(?)ati/ [-(?)at] on the head noun. Sentence (68b) illustrates proximate possession--reflected by absence of the suffix.

The obviative possessive suffix appears on a possessed

noun where the possessor is third person and, in conformity with the obviation principle, where the possessor is not co-referential with the subject. If the possessed noun is singular, and the possessor plural, the ending has a special shape /-(?)ami/ [-(?)am]. The ending follows the nonsingular and oblique endings--and when it follows either, its initial glottal stop is absent. If either the possessor or the possessed is nonsingular, the oblique ending is repeated--appearing both before and after the obviative possessive suffix. These facts are illustrated in the following table which gives the non-oblique and oblique forms corresponding to the English expressions 'the girl's dog', 'the girls' dog', 'the girl's dogs', and 'the girls' dogs':

(69) (a) Non-Oblique

		<u>Possessor NP</u> (i.e. /maana/)	
		[+sg]	[-sg]
<u>Possessed NP</u> (i.e. /po?ko/ )	[+sg]	maana-t po?ko-?at girl-OBL dog-POSS	maana-t pok-m-at girl-OBL dog-NSG-POSS
	[-sg]	mamanti-y po?ko-?am girls-OBL dog-POSS	mamanti-y pok-m-at girls-OBL dog-NSG-POSS



(69) (b)

Oblique

		<u>Possessor NP</u> (i.e. /maana/)	
		[+sg]	[-sg]
<u>Possessed NP</u> (i.e. /po?ko/)	[+sg]	maana-t po?ko-y-at girl-OBL dog-OBL-POSS	maana-t pok-mi-y-ati-y girl-OBL dog-NSG-OBL-POSS-OBL
	[-sg]	mamanti-y po?ko-y-ami-y girls-OBL dog-OBL-POSS-OBL	mamanti-y pok-mi-y-ati-y girls-OBL dog-NSG-OBL-POSS-OBL

(Notice that the /i/ of the nonsingular ending /mi/ is deleted before the /a/ of the obviative possessive ending.)

The proximate possessive occurs only in the oblique. This follows, since the meaning of the proximate is that the third person possessor is coreferential with the subject--the possessor and possessed being necessarily distinct, there is no way in which the proximate possessive construction can appear in subject position and therefore in non-oblique case. The proximate forms corresponding to (69b) are just two in number, differing only in terms of number of the possessed noun:

(70) Singular

poʔko-y

Nonsingular

pok-mi-y

The number of the possessor is, of course, not reflected at all, since the obviative possessive suffix is itself absent.

In addition to the absence of a possessive ending, the third person proximate possessive construction is characterized by the absence of an overt noun phrase in complement position. The identity of the possessor is recoverable, however, from the subject since it is necessarily coreferential with the latter.

First and second person possessive constructions are quite distinct from the third person cases just discussed. Obviation does not enter into first and second person possession. Thus, for example, the possessive constructions in (71) below are identical in both (a), where the subject and possessor are disjoint in reference, and (b), where the subject and possessor are coreferential:

- (71) (a) pam ʔi-poʔko-y miʔa  
 (he my-dog-OBL shot)  
 'He shot my dog.'

- (b) ni? ?i-po?ko-y mi?a  
 (I my-dog-OBL shot)  
 'I shot my dog.'

The person and number of the possessor are represented by prefixes conforming to the following paradigm:

(72)	<u>Singular</u>	<u>Nonsingular</u>
1	?i-	?ita?-
2	?i?-	?imi?-

These prefixes are attached directly to the head noun, which we assume to appear in the 'complementless' configuration portrayed in (65a) above. The possessor is represented solely by the prefix; it is not also represented by a pronoun appearing in complement position.

When a possessive prefix is combined with a stem whose first vowel is long, that vowel shortens, thus:

(73) <u>Stem</u>	<u>Prefixed Form</u>
qööqa	?i-qööqa ?i?-qööqa etc.
paasa	?i-pasa (~?i-vasa) ?i?-pasa etc.
maana	?i-mana ?i?-mana etc.

With a few stems--e.g. the kinship terms /-na/ 'father', /-ŋi/ 'mother', the glottal-final prefixes shorten by loss of the glottal:

(74) ?i-ŋi	'your mother'
?ita-ŋi	'our mother'
?i-na	'your father'
?ita-na	'our father'

Otherwise, the formation of first and second person possessive forms is quite regular.

Third person and non-third person possession are distinct in an additional respect. In first and second person possession of a plural animate noun, the construction is completely straight-forward--the possessive prefixes are simply combined with the plural form of the noun:

- |          |         |           |             |
|----------|---------|-----------|-------------|
| (75) ?i- | popko-t | 'my dogs' |             |
|          | ?i?-    | popko-t   | 'your dogs' |
|          |         | etc.      |             |

But in third person possession--as can be seen from table (69)--an unreduplicated form of the noun is used together with the /-mi/ nonsingular suffix, regardless of the pattern according to which the noun forms its plural when appearing outside the possessive construction.

#### 2.4.0. The Postpositional Phrase

The postpositional phrase, in its fullest form, is a complement-head structure which can be depicted in tree-form as,

(76)

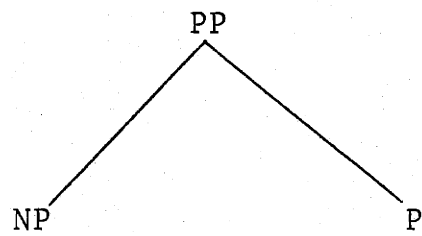

This structure is exemplified in,

(77)

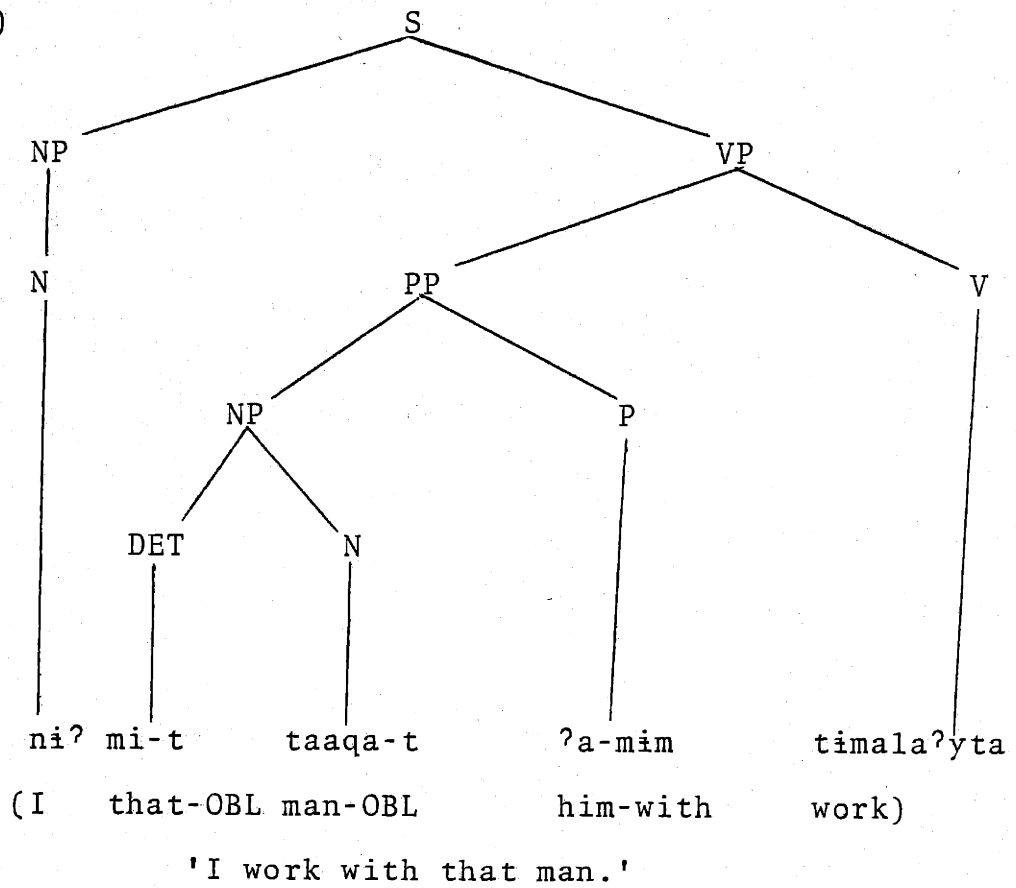

As expected, a noun phrase functioning as the object of the postposition is inflected for oblique case. The postposition itself consists of a stem--/mim/ in the case of the comitative postposition in the above example--and a prefix corresponding to the person of its object. In (77) above, /ʔa-/ is the prefix appropriate to the third person object. If the object were plural, this person-marking prefix would be followed immediately by the element /-mi/ (see section 2.1.3. above). Thus, for example,

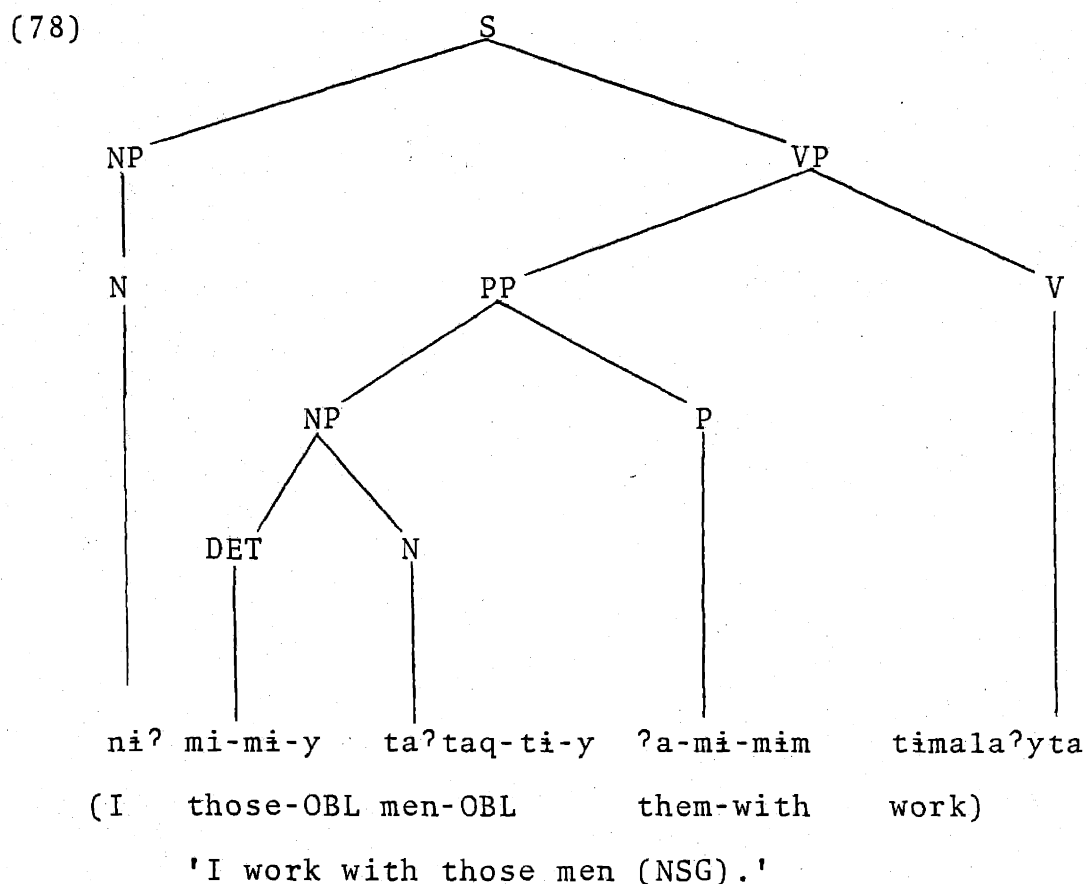

When the object of a postposition is first or second person, it is not represented by an overt phrase--rather, it is represented in the prefixal portion of the postpositional word. Consider, for example, the postposition in the following sentence:

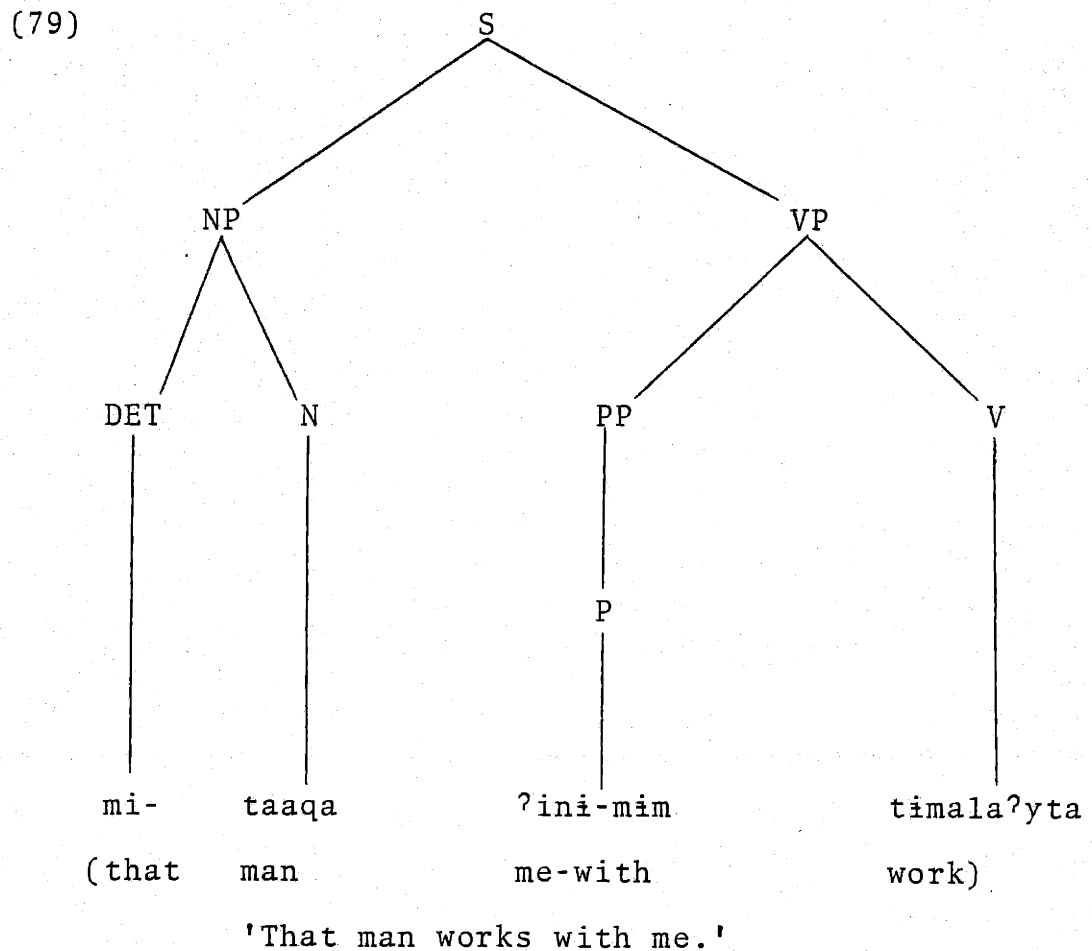

Here, the first person singular object of the postposition is



represented by the prefix /ʔini-/. The complete set of personal prefixes occurring with postpositions is displayed in the following paradigm:

(80)	<u>Singular</u>	<u>Nonsingular</u>
1	ʔini-	ʔita-(mi-)
2	ʔi-	ʔi-mi-
3	ʔa-	ʔa-mi-

The element /-mi-/ is parenthesized in the first person nonsingular to reflect the fact that it does not appear with certain postpositions. For example, /-mi-/ is regularly lacking in the first nonsingular form of the comitative. Hence, the full paradigm of the comitative appears as follows:

(81)	<u>Singular</u>	<u>Nonsingular</u>
1	ʔini-mim	ʔita-mim
2	ʔi-mim	ʔi-mi-mim
3	ʔa-mim	ʔa-mi-mim

By contrast, the dative postposition /-mi/ (irregularly /-w/

in the third singular) takes the /-mi-/ element throughout the nonsingular, as can be seen in the following paradigm:

(82)	<u>Singular</u>	<u>Nonsingular</u>
1	?ini-mi	?ita-mi-mi
2	?ii-mi	?i-mi-mi
3	?a-w	?a-mi-mi

Notice the slight irregularity in the second person singular where, unaccountably, the prefix is long /?ii-/ rather than the usual short /?i-/. The dative postposition is exemplified in the following sentence:

(83) (a) ni? tiyo?ya-t ?a-w say?ti  
 (I boy-OBL him-to smile)  
 'I smiled at the boy.'

(b) ?im ?ini-mi taci-t tiiva-ni  
 (you me-to ball-OBL throw-FUT)  
 'You throw the ball to me.'

If the object of the postposition (regardless of the person category to which it belongs) is coreferential with the subject of the sentence, again it is not represented overtly by a noun phrase. Instead, it is represented by the reflexive prefix /naa-/ in the postpositional word. Consider, for example, the dative postposition in the following:

(84)

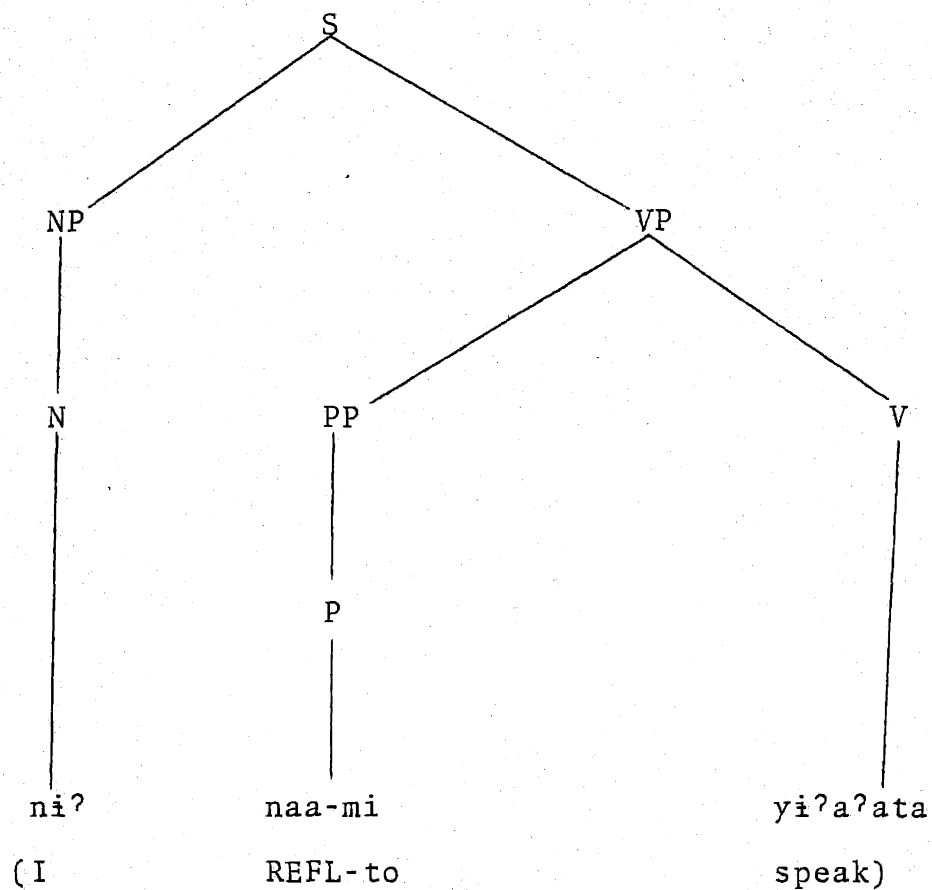

This prefix is appropriate wherever the object is understood as coextensive with the subject--thus, it subsumes the reciprocal as well as the reflexive. The reciprocal interpretation is available where the subject and understood object are non-singular, as in,

(85)

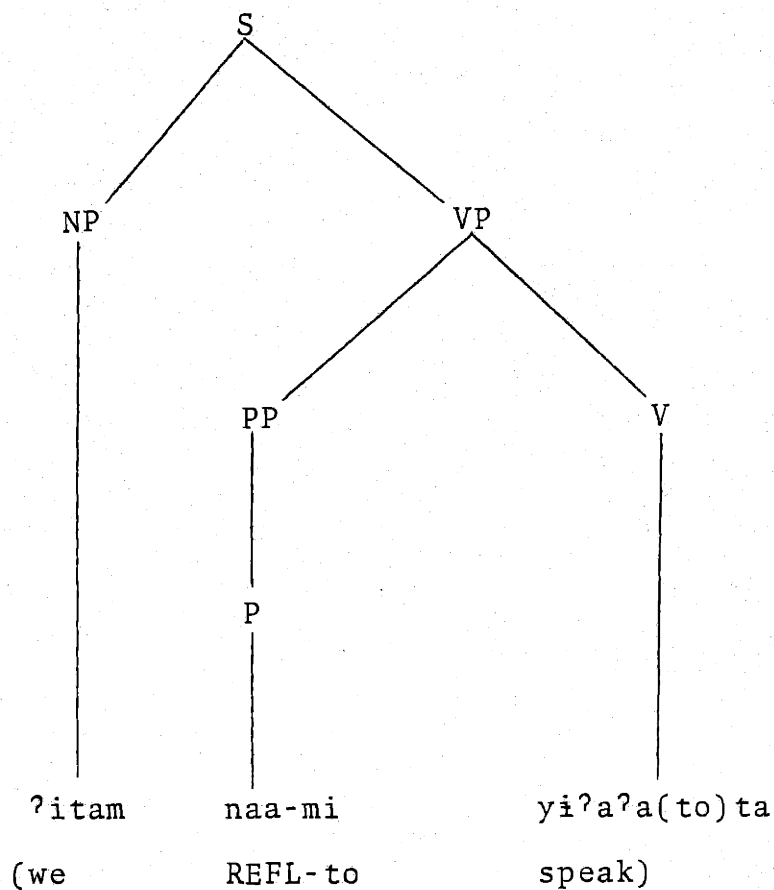

(a) 'We are speaking to each other.'

(b) 'We are speaking to ourselves.'

(These are plural with /-to-/ in the verb, dual otherwise-- see 2.1.2. above.)

The reflexive and reciprocal can be viewed as another instance of the obviation principle in Hopi. Thus, the reflexive form of a postposition represents the proximate--i.e. necessary coreference between the subject of the sentence and the understood object of the postposition. The non-reflexive form represents the obviative--i.e. necessary disjoint reference between the subject and object of the postposition. In post-positional phrases, obviation applies to all persons; it is not restricted to third person as it is in the case of the possessive construction.

The examples so-far cited show the postpositional phrase in its complement function--namely, in which it is a dependent of a verb. Certain postpositions can function as predicators as well. This usage is exemplified with the comitative in the following sentences with their phrase-markers:

(86) (a)

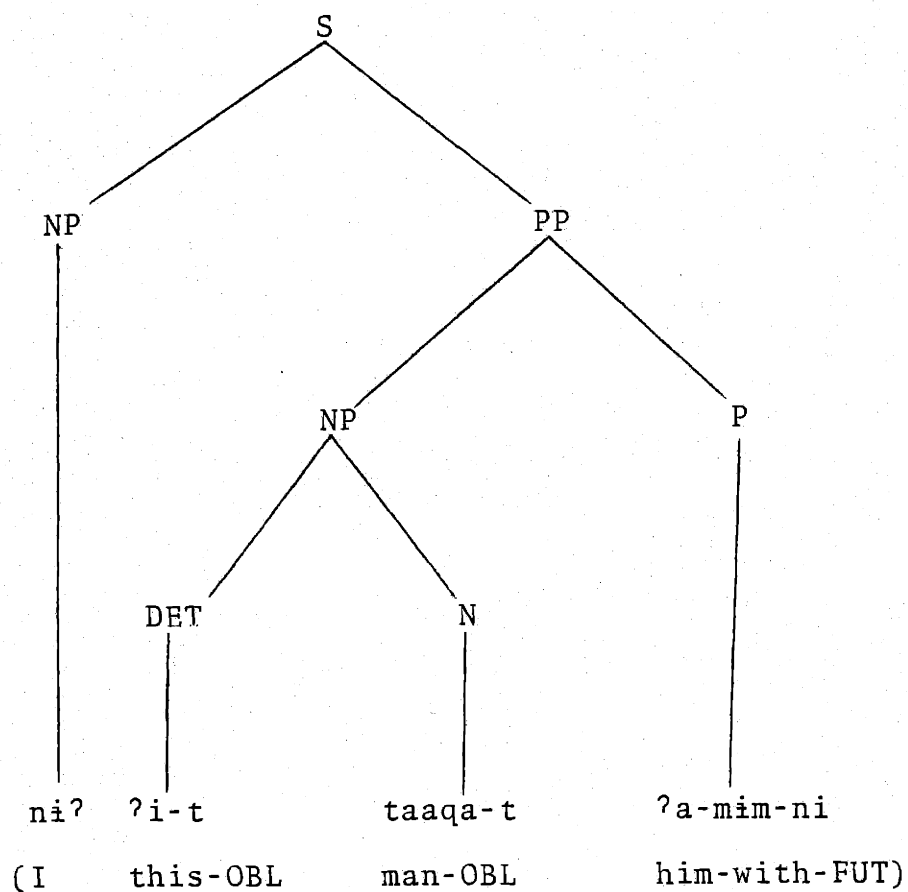

'I will accompany this man.'

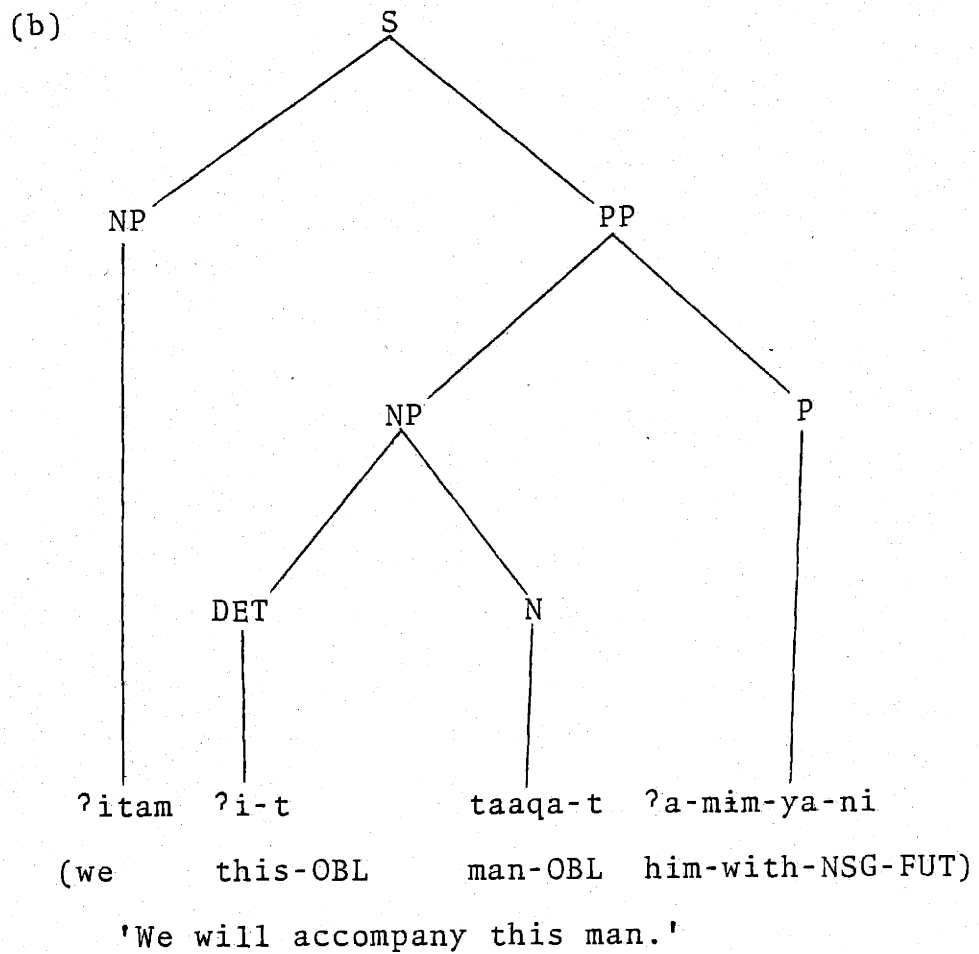

In predicate function, if the postposition is not accompanied by a suffix--like the future suffix /-ni/ or the nonsingular /-ya/ suffix, as in (86) above--it appears in its pausal form. Thus,

- (87) ni? ?i-t      taaqa-t ?a-mim?a  
 (I    this-OBL man-OBL him-with)  
 'I am with this man.'

For a discussion of pausal forms, see 1.7. above.

When in its predicate function, a postposition is immediately followed by a suffix other than /-ni/ or /-ya/, an incremental element of the shape /-ni-/ (which is not to be confused with the future /-ni/) intervenes between the postposition and suffix. For example, this element will appear if the usitative (USI) suffix /-ŋ<sup>w</sup>i/ is attached to the postposition as in:

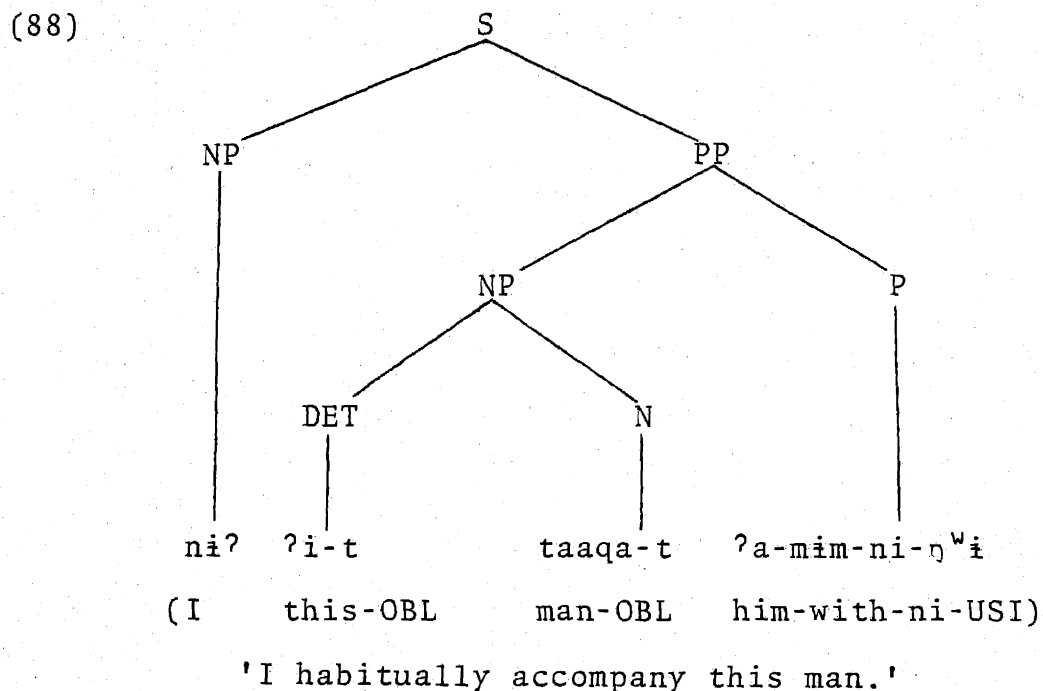



This incremental /-ni-/ can co-occur with the future /-ni/ if the latter is followed by a suffixal conjunction, as in:

- (89) ?im ?ini-mim-ni-ni-t      ?iic yïiyiwsî-ni  
 (you me-with-ni-FUT-CONJ early get dressed-FUT)  
 'If you wish to go with me, then be getting dressed early.'

In (89), the /-ni-/ element is followed by the future /-ni/, followed by the proximate conjunction /-ti/ [-t].

The postposition /-mi/, referred to by the term 'dative' above, also has the directional meaning, appropriately labelled 'allative'. In this meaning, /-mi/ may function as predicator, as in:

- (90) (a) ?im momoy-mi-y      ?a-mi-mi-ni  
 (you women-NSG-OBL third-NSG-to-FUT)  
 'You go to the women.'

- (b) ?im ?ita-mi-mi-ni  
 (you us-NSG-to-FUT)  
 'You come to us.'

In general, postpositions with directional or locative meaning may be used in this way, as can the comitative illustrated earlier. This usage is not considered elliptical. However, in the following sentence, the second clause is elliptical and a particular verb is understood to be missing--to wit, /tiiva/ 'to throw', appearing overtly in the first clause:

- (91) ?im tiyo?ya-t ?a-w taci-t tiiva-q pi? pam  
 (you boy-OBL him-to ball-OBL throw-CONJ then he  
 pi-t tiwat ?ini-mi-ni  
 it-OBL too me-to-FUT)  
 'You throw the ball to the boy and then he will  
 (throw) it to me.'

It is not our purpose here to present a complete account of Hopi postpositions. The system is quite rich, and there is a great deal about the system which we do not yet understand. For our purposes, in this study, it will be sufficient merely to exemplify the category and to present our basic understanding of the structure into which it enters, as we have done above.

In addition to their appearance in paradigms of the type illustrated for the comitative and dative-allative above,

certain postpositional stems combine with deictic elements to form adverbials. Thus, for example, the locative postposition /-pe/ [-p] 'in, at' appearing in its strictly postpositional function in,

- (92) Poʔk<sup>y</sup>aya kiihi-t ʔe-p qati<sup>2</sup>  
 (Poʔk<sup>y</sup>aya house-OBL it-in sit)  
 'Poʔk<sup>y</sup>aya is sitting in the house.'

also appears in the locative adverbials /yepe/ [yep] 'here' and /pepe/ [pep] 'there'. Evidently, the deictic categories involved here are the same as those involved in the determiners /ʔiʔi/ [ʔiʔ] 'this' and /pami/ [pam] 'that (near)'. And, in this instance at least, there is an inescapable resemblance between the initials of the adverbials (i.e. /y-/, /p-/) and the initial portions of the determiners (i.e. /ʔi-/, /p-/). The formation of locative adverbials, however, is not entirely regular.

A third adverbial, the distal, involves an initial portion /ʔaya-/, and in the case of the locative, evidently a distinct stem element /-mo/ [-m]--thus, /ʔayamo/ [ʔayam] 'there (distant)'. The stem appearing in this form does not occur productively as a locative, but does appear in the

interrogative form of the locative adverbial--to wit, /haqamo/ [haqam] 'where at'.

Another usage which should be mentioned before we leave the topic of postpositions is illustrated by the allative in the following sentence:

(93) Mano pas-mi-ni

(Mano field-to-FUT)

'Mano will go to the field.'

The allative, and several other postpositions as well, can take an incorporated noun object. In (93), the noun stem /paasa/ 'field' is directly attached to the allative stem--the shortened form of the noun is produced by regular phonological processes described in 1.2. above. Sentence (93) is a close paraphrase of (94) below, in which the full complement-head structure is used:

(94) Mano paasa-t ?a-w-ni

(Mano field-OBL it-to-FUT)

Parallel use of the locative postposition--which has the shape /-ve/ with an incorporated noun stem--is exemplified by the following:

- (95) Mano pas-ve timala?yta  
 (Mano field-in works)  
 'Mano is working in the field.'

This is closely paraphrased by:

- (96) Mano paasa-t ?e-p timala?yta  
 (Mano field-OBL it-in work)  
 'Mano is working in the field.'

#### 2.5.0. The Verb

In this section, we present certain elementary observations concerning the Hopi verb. We discuss first the primary subcategories of verbs, introducing in the course of the discussion the reflexive-reciprocal constructions as well. Following that, we make brief observations concerning the categories of tense and aspect.

2.5.1. Verbal Subcategories

We will assume that the rules of the Hopi base recognize a phrasal category which dominates the verb and its complements. For the present, we will symbolize this category in the traditional way as VP. Thus, for example, we will assign to a transitive sentence the following structure:

(97)

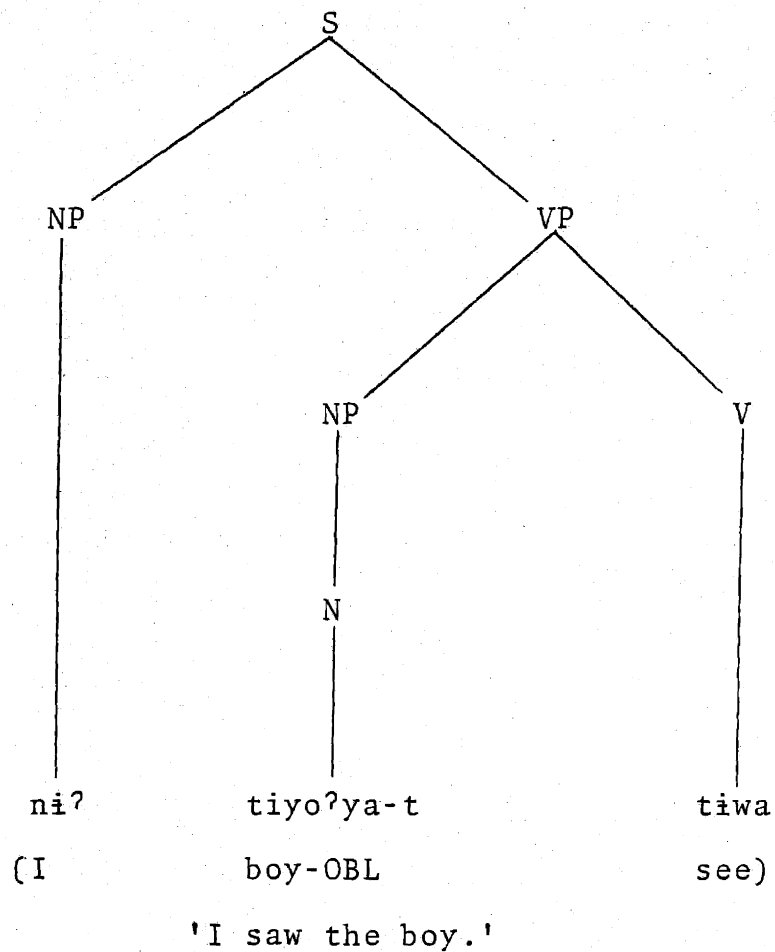

The verb /tiwa/ 'to see' is the head (or the nucleus) of the VP. Hopi, being predominantly an SOV language, the verb appears in final position.

By contrast with (97), an intransitive sentence will be assigned a structure in which VP dominates the verb alone, as in:

(98)

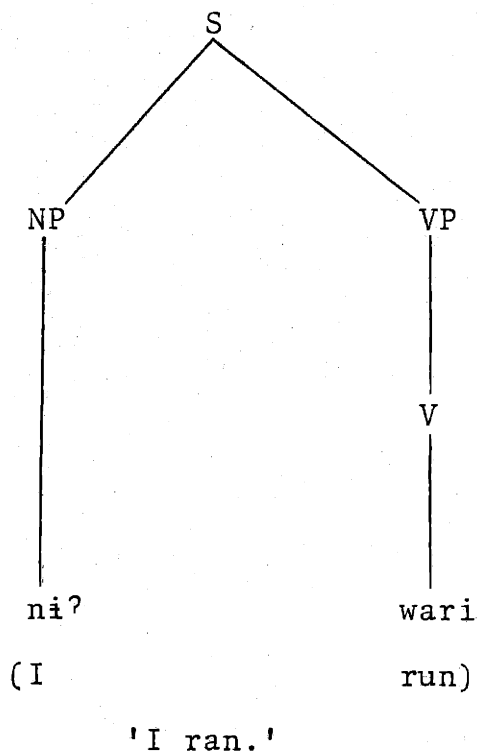

(99)

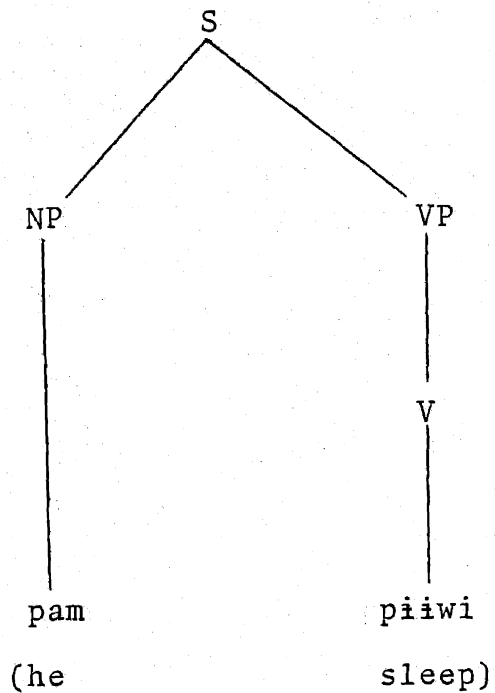

'He is sleeping.'

Or, with the corresponding plural verbs, /yi?ti/ and /took<sup>y</sup>a/, respectively, we have:

(100) ?itam yi?ti

(we run)

'We ran.'



- (101) pima took<sup>ya</sup>  
 (they sleep)  
 'They are sleeping.'

Verbs of the type represented in (98-101) are presumably associated with the strict subcategorization feature [\_\_\_\_\_]--i.e. they are members of a class which may appear alone in VP. In similar fashion, complement-taking verbs are associated positively with the following subcategorical features:

- (102) [NP \_\_\_\_\_]  
 [NP NP \_\_\_\_\_]  
 [NP PP \_\_\_\_\_]  
 [PP \_\_\_\_\_]

Thus, for example, verbs associated with the frame [NP \_\_\_\_\_] are the transitive type taking an obligatory NP object. Examples of such simple transitive verbs together with their phrase markers are:

(103)

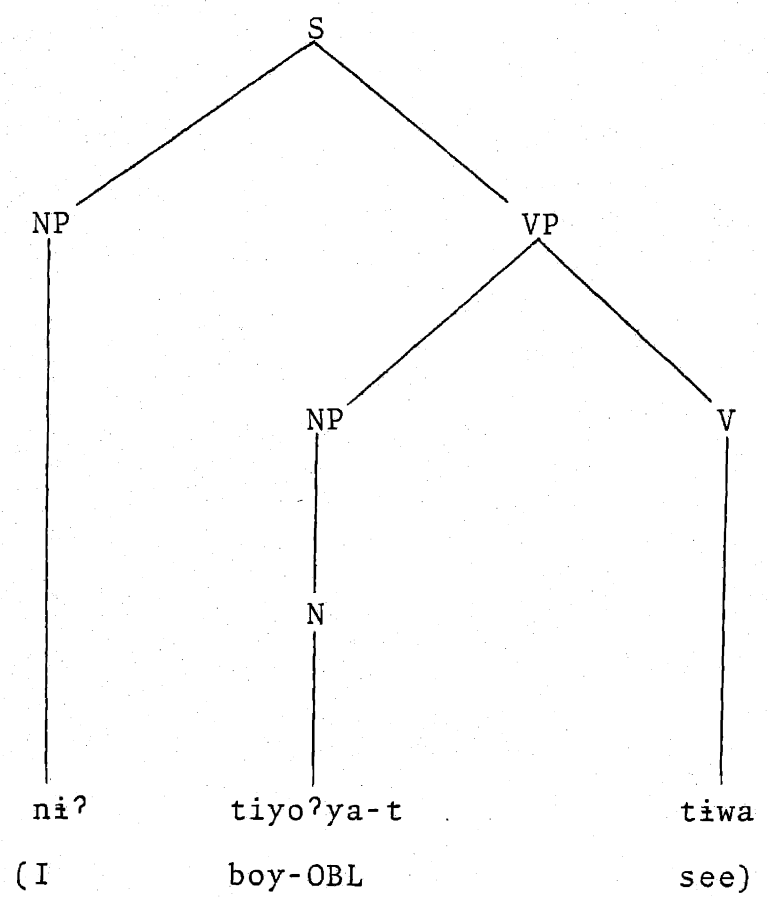

(I            boy-OBL            see)

'I saw the boy.'

(104)

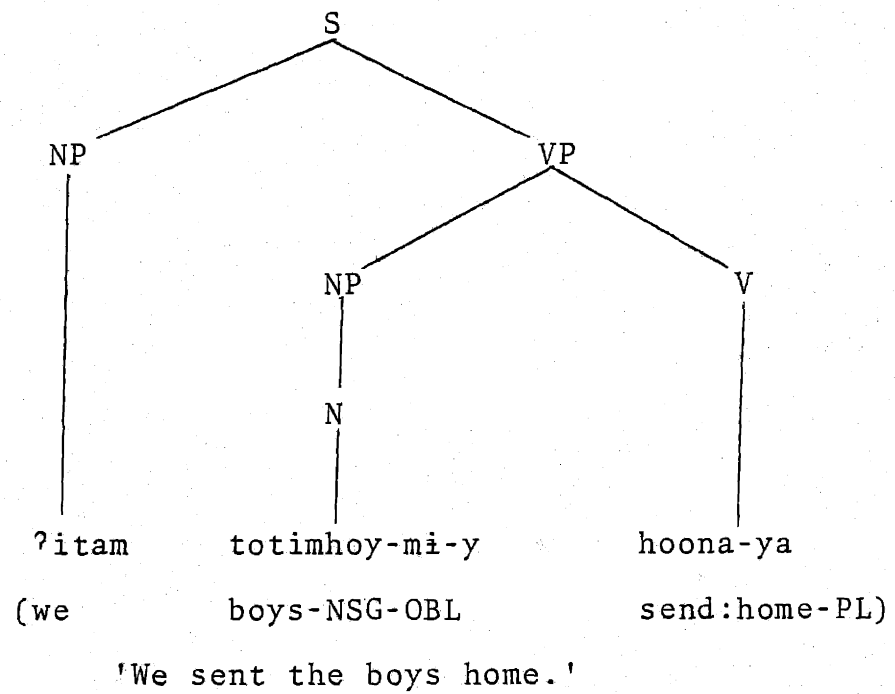

(105)

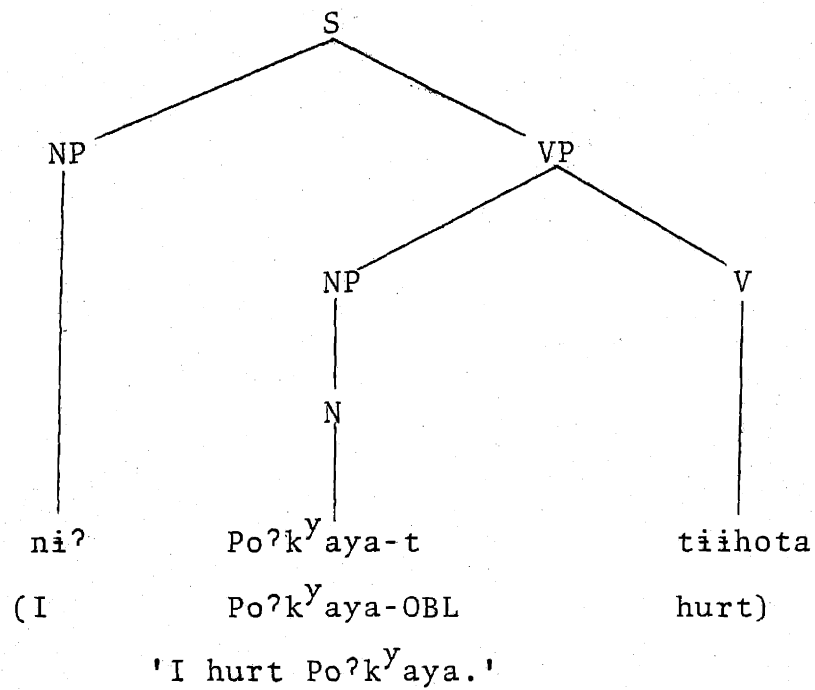

In (103-105), the subject and object are disjoint in reference. However, if the object NP in (105), for example, were coreferential with the subject NP, then the object would not be represented by a NP but rather by a prefix on the transitive verb:

(106) ni? naa-tihota  
 (I REFLEX-hurt)  
 'I hurt myself.'

which we assume has the phrase marker,

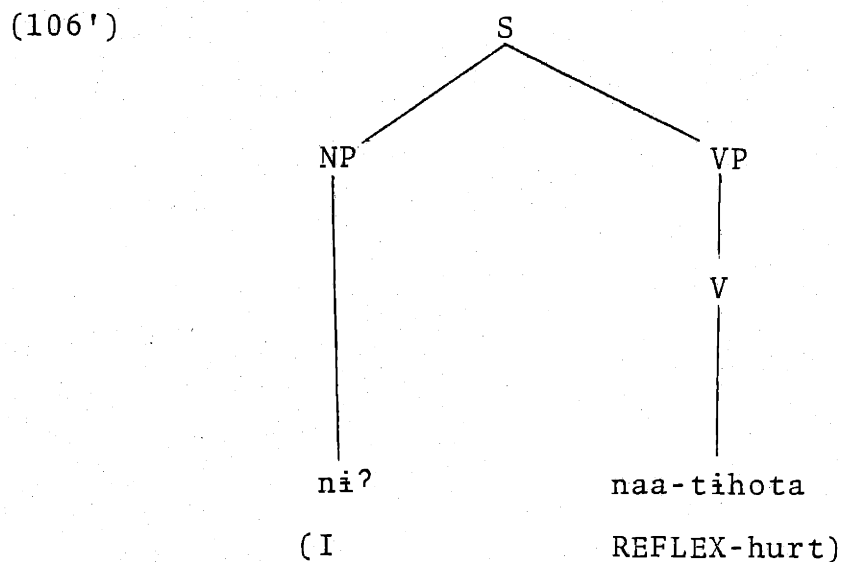

The /naa-/ prefix on the verb is the reflexive-reciprocal and is identical to that appearing on postpositions, as discussed in section 2.4. above.

As we suggested in the discussion of postpositions, the reflexive-reciprocal may be thought of as a special case of the obviation principle in Hopi. That is, the reflexive form of the verb, e.g. [naa-tihota], represents the proximate (or the coreference case) and the non-reflexive, the obviative (or the non-coreference case). Here as with postpositional phrases, the obviation principle applies regardless of person. Thus, for example, compare the following sentences involving a first person subject:

(107) ni? sik<sup>w</sup>i-t tiki

(I meat-OBL cut)

'I cut the meat.'

(108) ni? na-tki

(I REFL-cut)

'I cut myself.'

It is possible that the reflexive-reciprocal in Hopi should be

regarded as lexically governed. That is, although it is easily formed on a great many verbs, e.g.

(109)	tiki	na-tki	'to cut self'
	meewa	naa-mewa	'to restrain self'
	kiiki	naa-kiki	'to bite self'
	?aama	naa-?ama	'to bury self'

there are also, to be found, a great many verbs for which the reflexive is ill-formed. Consider here such verbs as,

(110)	hoona	*naa-hona	'to send:home self'
	tiwa	*naa-tiwa	'to see self'
	miima	*naa-miima	'to roll self'
	hoyok-na	*naa-hoyok-na	'to move self'

It is possible that the ill-formedness of these forms is due to semantic reasons and not due to idiosyncratic lexical government. However, at this point we cannot reach a definitive decision in this regard.

In addition to the simple transitive verbs of the type

illustrated so far, Hopi appears to have a small number of "double transitives", that is, verbs having two object NP's. Verbs of this type are extremely rare, one example being /maqa/ 'to give' as in,

- (111) ni? Po?k<sup>y</sup>aya-t siiva-t maqa  
 (I Po?k<sup>y</sup>aya-OBL money-OBL give)  
 'I gave Po?k<sup>y</sup>aya money.'

However, there is some question as to whether verbs like /maqa/ are to be considered underlyingly distinct from a much more common type--more specifically, verbs subcategorized as,

[NP PP \_\_\_\_\_] .

It is conceivable that a sentence like (111) is derived from an underlying source in which the indirect object--in this case, /Po?k<sup>y</sup>ayat/--appears in a postpositional phrase, that is,

(112)

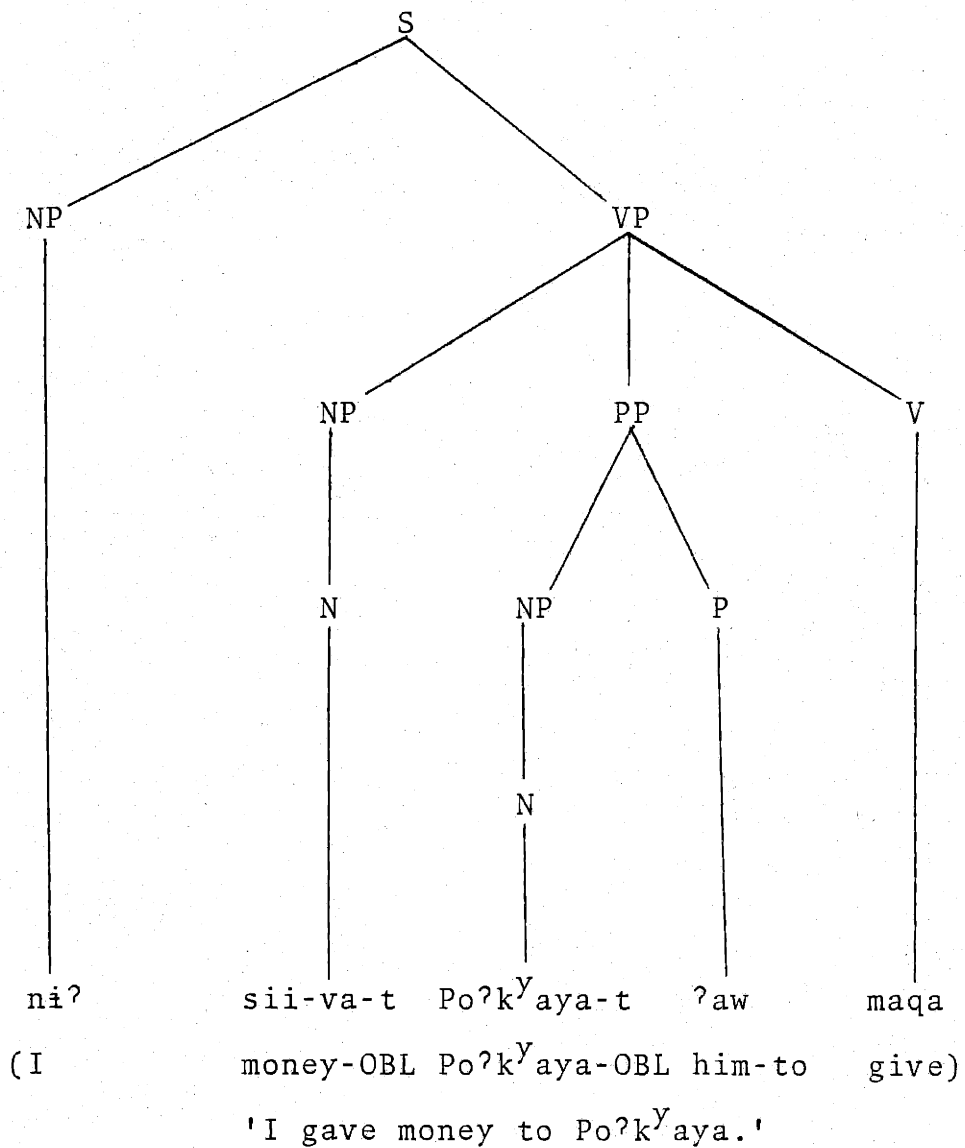

A rule optionally deletes /?aw/ from (112), and reorders the noun phrase giving (111). The optionality of such a rule of course implies that both (111) and (112) should be well-formed. And, in fact, (111) is a well-formed sentence synonymous with (112).



It is possible, therefore, that verbs like /maqa/ which appear on the surface to take double objects, will instead be subcategorized to appear in the frame, [NP PP \_\_\_\_]. If so, however, the rule deleting a postposition, to derive the "double transitive" surface form is lexically governed, since most [NP PP \_\_\_\_]-verbs cannot delete the postposition. Thus, for example, the verb /tiiva/ 'to throw', as in (113) below, may appear in the frame [NP PP \_\_\_\_]:

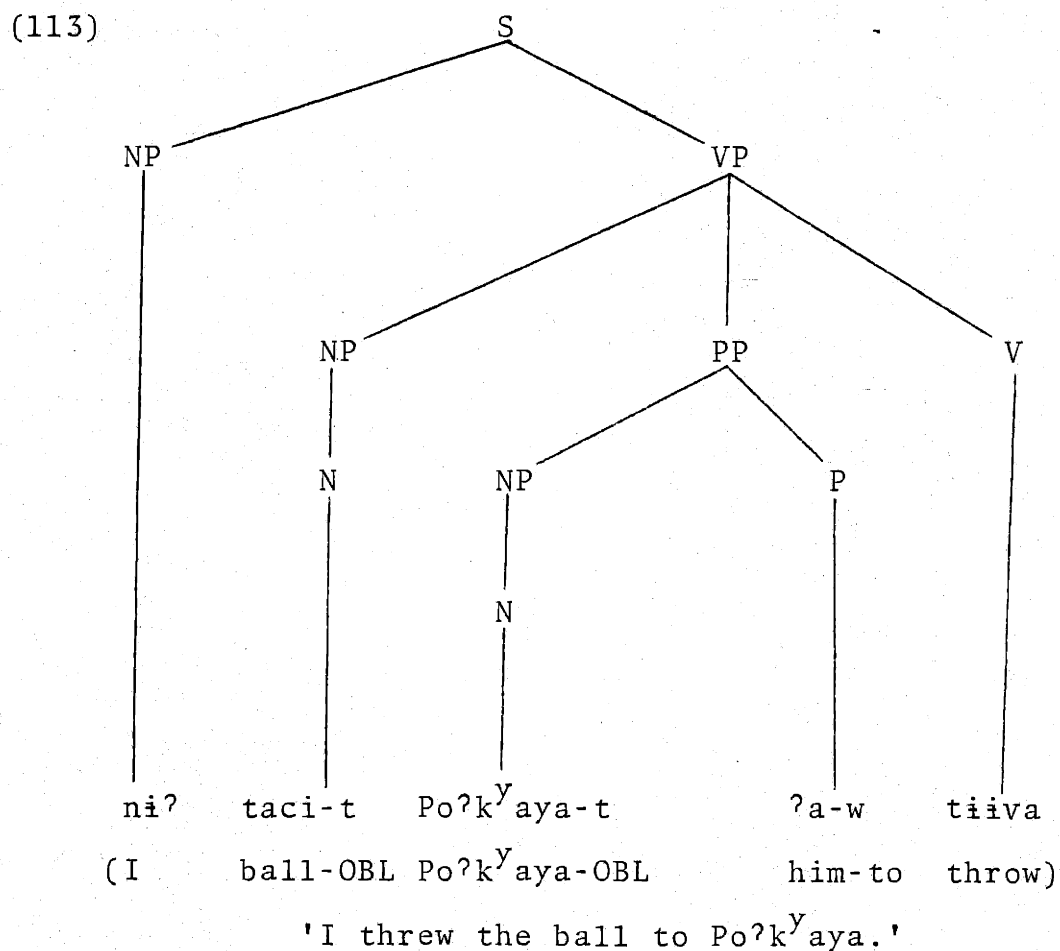

But the suggested 'dative movement' rule here yields ungrammatical,

(114) \*ni? Po?k<sup>y</sup>aya-t taci-t tiiva.

In connection with the "double transitive" category, it is appropriate to mention the Hopi causative construction. Under the appropriate conditions, the causative gives rise to verbs selecting the [NP NP \_\_\_\_\_] frame.

The Hopi causative suffix is /-na/ and can be affixed to both transitive and intransitive verbs--but only to certain ones. In other words, here as with reflexive-reciprocals, the causative is lexically governed. Causatives, as is well known, have the property of introducing an additional argument into the structure--and this is true also in Hopi. Thus, for example, it can take an intransitive verb, for example, [?ööyi] 'to be satiated', as in,

(115) ni? ?ööyi

(I satiated)

'I am satiated.'

and make it into a transitive in which the logical subject of the underlying intransitive appears as object:

- (116) pam ni-y ?öy-na  
 (he me-OBL satiate-CAUS)  
 'He filled me up (on food).'

There are numerous causatives formed on intransitive verbs; other examples being the following:

(117) <u>Intransitive</u>		<u>Causative</u>
piiwi	'to sleep'	piw-na
paklawni	'to cry'	paklaw-na
mini	'to fall'	mini-k-na
wari	'to run'	wari-k-na
?aasi	'to wash hair'	?as-na
siwi	'to spill (e.g. salt)'	siwi-k-na
wiwa	'to trip'	wiwak-na
ta?ki	'to push over'	ta?ki-k-na

The above are quite regular in their formation. However, some

are quite irregular--as for example,

(118)	<u>Intransitive</u>		<u>Causative</u>
	noosa	'to eat'	nop-na 'to feed'

The morphological formation of the causative is not as yet fully understood. We introduce them here only to illustrate the syntactic fact that the formation of a causative involves the addition of an argument to the sentence. Causatives formed on transitive verbs are less common. Those that exist have double objects as illustrated in the following:

(119)	ni?	kiiyi-t	hiiko
	(I	water-OBL	drink)
	'I drank water.'		

(119')

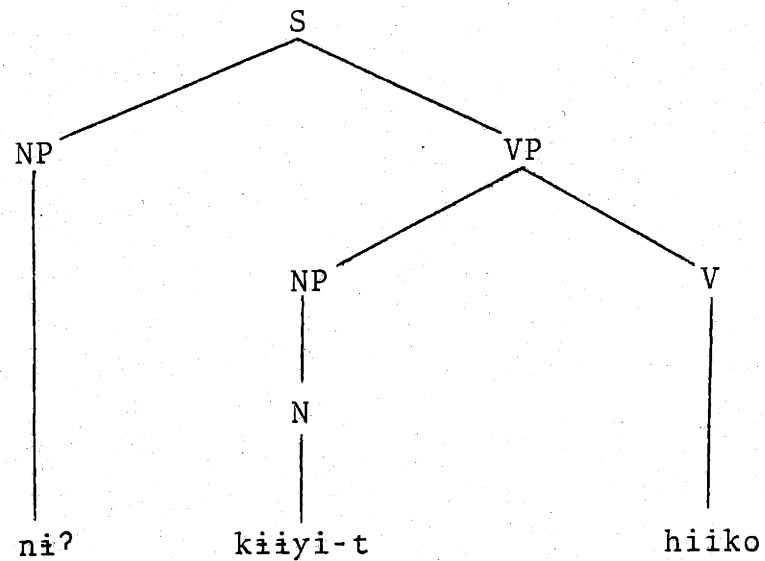

(120) ni? Po?k<sup>y</sup>aya-t kiiyi-t hik<sup>w</sup>-na  
 (I Po?k<sup>y</sup>aya-OBL water-OBL drink-CAUS)  
 'I made Po?k<sup>y</sup>aya drink water.'

(120')

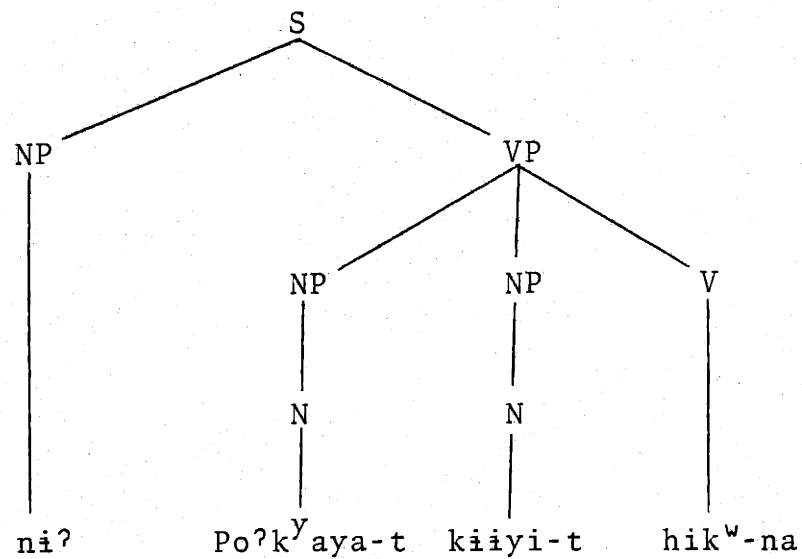

Other examples are:

(121) ni? hopilavayi-t titiqayi  
 (I Hopi language-OBL learn)  
 'I am learning Hopi (i.e. the Hopi language).'

(122) ni? pahan-mi-y hopilavayi-t titiqay-na  
 (I white people-OBL Hopi-OBL learn-CAUS)  
 'I am teaching white people Hopi.'

(123) pam taapalo-t ?isi?ta  
 (she shawl-OBL put-on)  
 'She put on a shawl.'

(124) pam mö?wi-y taapalo-t ?isi?-toy-na  
 (she mö?wi-OBL shawl-OBL put-on-toy-CAUS)  
 'She put a shawl on her mö?wi (daughter-in-law).'

Since the erstwhile subject of the simple transitive verb appears as an object of the derived causative, the latter

belongs to the class selecting the subcategorial frame  
[NP NP \_\_\_\_\_].

In addition to verbs selecting "direct objects", a great many verbs of Hopi select postpositional complements. One such verb has already been exemplified--i.e. the verb /tiiva/ 'to throw', which may appear with a NP object and, optionally, with a postpositional complement as well--as in (113) above.

There also exist verbs which may not accept NP objects but do select postpositional complements. Some of these, in fact, require a postposition, as for example, /yori/ 'to see', exemplified in

- (125) ni? ?ita-ŋi-y        ?a-w    yori  
      (I    our-mother-OBL her-to see)  
      'I saw our mother.'

with the phrase marker:

(125')

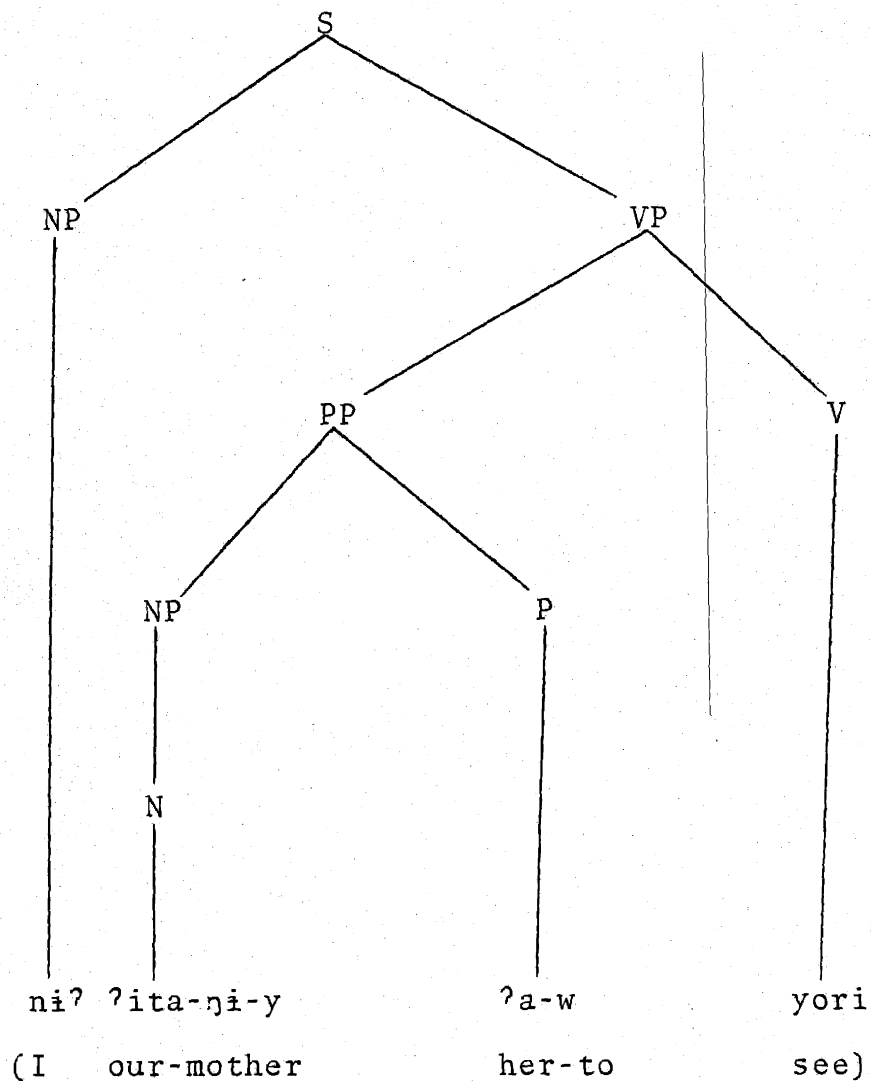

For a great many others, the postposition is optional--/paki/, for example, can appear with a postpositional complement, as in,



(126)

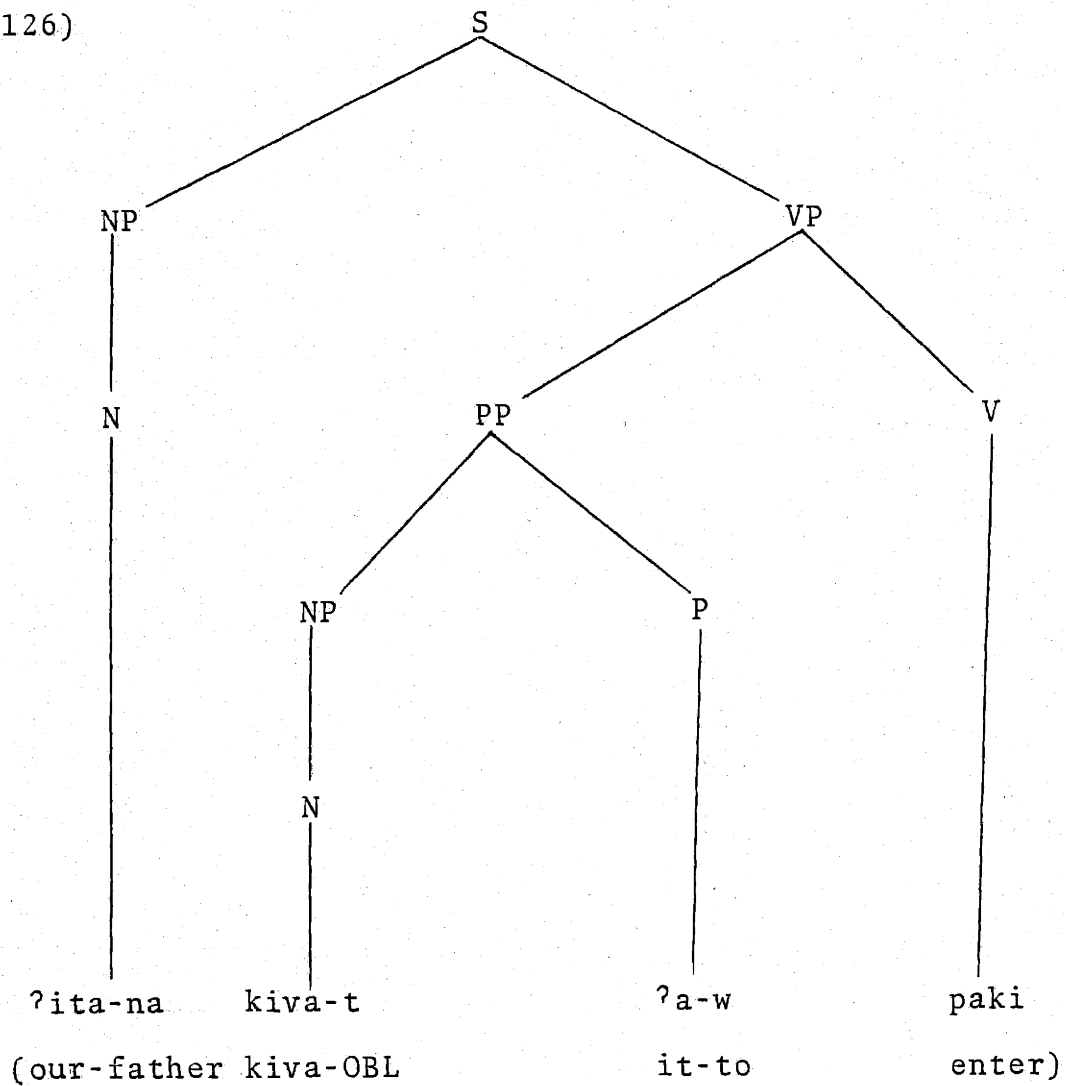

'Our father entered the kiva.'

or, it can appear without a complement, as in,

(127)

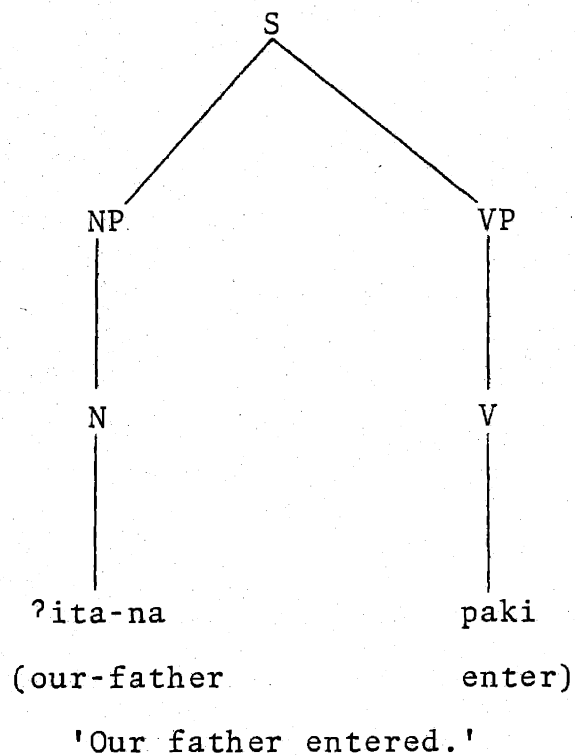

Finally, there exists verbs which require both an NP object and a postpositional complement--i.e. verbs which appear obligatorily in the frame [NP PP \_\_\_\_\_]. The verb /tavi/ 'to send, give, put (single obj.)' illustrates this type:

(128)

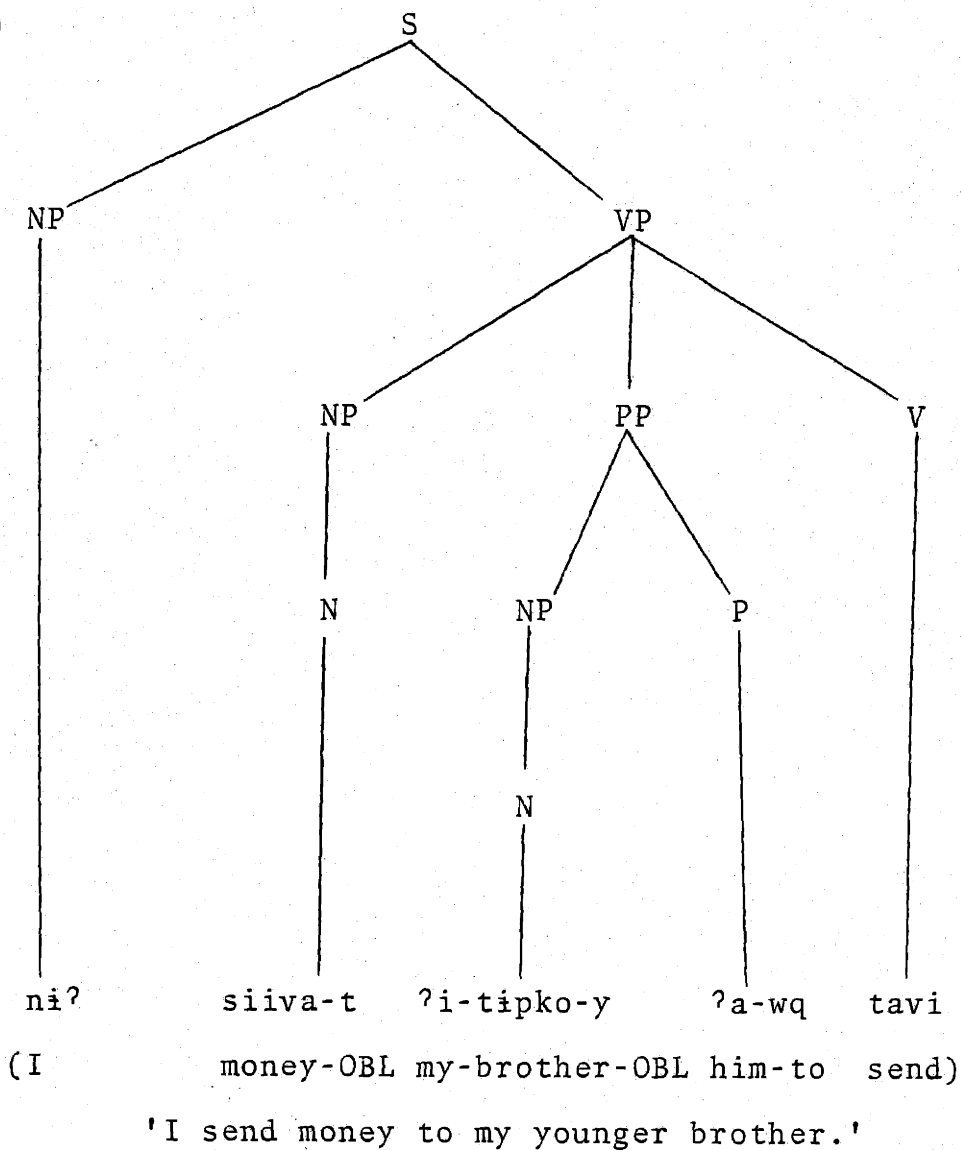

### 2.5.2. Remarks on Tense and Aspect

Most Hopi verbs occur in perfective-imperfective pairs. The perfective is, morphologically speaking, the simpler of the two forms--at least this is so in the majority of cases. It is not possible, so far as we can tell at this point, to

predict the forms with complete accuracy. A variety of patterns occur, of which we will illustrate only a few in this section.

A number of verbs can be viewed as forming their imperfective by means of suffixation to a base identical to the perfective. Verbs of this type are exemplified in (129) below:

(129)	<u>Perfective</u>	<u>Imperfective</u>	
	mööya	mööya-nta	'to put out to dry'
	siin <sup>y</sup> a	siin <sup>y</sup> a-nta	'to peel'
	pö?qa	pö?qa-nta	'to weave'
	niina	niina-nta	'to kill (non-plural object)'
	hoona	hoona-nta	'to send home'
	meewa	meewa-nta	'to ask someone to desist'
	peena	pen-ta	'to write'
	paki	paki-wta	'to enter'
	tiwa	tiwa-?yta	'to find, see'

A number of such verbs belong to the class which takes the k-increment when suffixed--this increment typically appears in its underlying, vowel-final shape when followed by an imperfective ending:

(130)	<u>Perfective</u>	<u>Imperfective</u>	
	k <sup>w</sup> ana	k <sup>w</sup> ana-ki-nta	'to crack'
	laŋa	laŋa-ki-nta	'to pull'
	wari	wari-ki-wta	'to run (non-plural subject)'
	waʔö	waʔö-ki-wta	'to lie down'

Another pattern involves the process of reduplication, discussed in earlier sections in connection with its function in the number marking system (cf. 2.1. above and Chapter 1). A number of Hopi verbs can be viewed as forming their imperfective by reduplication upon a base identical to the perfective--e.g.

(131)	<u>Perfective</u>	<u>Imperfective</u>	
	tiki	titki	'to cut'
	yiki	yiyki	'to finish'
	paki	papki	'to enter'
	yama	yayma	'to exit'
	tiʔi	tiʔtiʔi	'to buy'
	maqa	mamqa	'to give'
	coʔo	cocoʔó	'to jump'
	ʔaasi	ʔaaʔasi	'to wash hair'

haawi	haahawi (~hahawí)	'to climb down'
tiiva	titivá	'to throw'
k <sup>w</sup> iiva	k <sup>w</sup> ik <sup>w</sup> ivá	'to boil'

The pattern of reduplication seen here is similar to the initial reduplication seen in nouns (see 1.3. above). A number of verbs, however, have an imperfective form which involves reduplication of the final syllable of a disyllabic base. In addition to the reduplication, the imperfective form has a suffix /-ta/:

(132)	<u>Perfective</u>	<u>Imperfective</u>	
	k <sup>w</sup> ala	k <sup>w</sup> alala-ta	'to boil (inter.)'
	siwi	siwiwi-ta	'to dribble out'
	ri <sup>?</sup> pa	ripapa-ta	'to slip (as rope)'
	miima	mimama-ta	'to roll (as ball)'
	nõna	nõna <sup>?</sup> na-ta	'to exit (plural subject)'
	cölo	cölölö-ta	'to sprinkle (as rain)'
	cala	calala-ta	'to scatter (as corn being shelled)'
	cina	cinana-ta	'to drip (as leak in a roof)'
	pa <sup>?</sup> to	patoto-ta	'to pop (as popcorn)'

Certain derived verbs mark the perfective-imperfective distinction within the derivational suffix--as is the case, for example, with verbs built upon the 'factorial' suffix /-ta/ (PERF), /-lawi/ (IMPERF) 'to make, build':

(133)	<u>Perfective</u>	<u>Imperfective</u>	
	pik-ta	pik-lawi	'to make piiki'
	kitik-ta	kitik-lawi	'to make parched corn' (cf. /kitiki/)
	kii-ta	kii-lawi	'to build a house' (cf. /kiihi/)

In a limited number of cases, it is not appropriate to view the imperfective as formed from a base identical to the perfective. For one type, at least, the reverse appears to be the case. Consider, for example, the stance verbs exemplified in (134) below:

(134)	<u>Perfective</u>	
	qati-pti	'to sit down, to get up'
	wini-pti	'to stand up'

Imperfective

qati	'to be sitting (non-plural subject)'
wini	'to be standing (non-plural)'

The suffixal element appearing in the perfectives here is evidently related etymologically to the verb /piti/ 'to arrive (non-plural)'.

A number of verbs are, from a synchronic point of view, entirely idiosyncractic in terms of the perfective-imperfective distinction:

(135) Perfective Imperfective

paklawi	pakmimi-ya	'to cry'
nöosa	tiimoyta	'to eat (non-plural subject)'
nöönösa	noonova	'to eat (plural subject)'
yi?a?ayki	yi?a?ata	'to speak'

Finally, a number of verbs, and verb-forming derivational endings, are inherently either perfective or imperfective and apparently lack an aspectual partner--e.g.



(136) Perfective Imperfective

qööha	---	'to make a fire'
co?co?a	---	'to die down (of fire)'
kiva	---	'to bring'
tavi	---	'to bring'
?oya	---	'to put, send (plural object)'
yoohi	---	'to break, shatter'
-to	---	'to go and V'
-ti	---	'to become'
---	hohonaqa	'to play'
---	piiwi	'to sleep (non-plural)'
---	took <sup>y</sup> a	'to sleep (plural)'
---	tayta	'to look at'
---	sasqa	'to go back and forth'
---	tii?i?ta	'to sew'
---	-nima	'to go around V-ing'
---	-ma	'to go along V-ing'

The meaning of the perfective aspect is relatively straightforward. It denotes completion of the action or process depicted by the verb in relation to a point in time. Thus, in the simplest possible case, where the temporal reference-point is the present, the perfective aspect of a non-future verb form is appropriately used to describe an event in

the past:

(137) mi? taaqa paki

(that man enter(PERF))

'The man entered.' 'The man has entered.'

With verbs which are inherently durative--as opposed to momentaneous--the perfectivity can relate either to the end-point of the action or process or to its beginning. The verb of (137) is momentaneous in Hopi, but the verb of (138) below is durative, and therefore allows either the terminative (a) or the inceptive (b) interpretation of the perfective aspect:

(138) mi? taaqa wari

(that man run(PERF))

(a) 'The man ran/has run.'

(b) 'The man started running/has started running.'

The meaning of the imperfective is, by contrast, much less straightforward. We suspect that a proper understanding of the imperfective will reveal that it is semantically heter-

ogenous and that the different morphological patterns involved in its formation correspond to differences in meaning. In the clearest case, the imperfective denotes an action or process which is "on-going" as of the time of reference. Thus, the imperfective of (138)--given as (139) below--is appropriately used to describe an event in progress at the present or at some point in time prior to the present:

- (139) mi? taaqa wari-ki-wta  
 (that man run-ki-IMPERF)  
 'The man is running.'  
 'The man was running.'

The situation with (137) above, however, is somewhat more complex. It has two imperfective forms, at least. One of these is built upon the reduplicative pattern of (131), which is, properly speaking, a 'repetitive' rather than a simple imperfective,

- (140) mi? taaqa papki  
 (that man enter(IMPERF))  
 'The man keeps going in (and out).'

Another imperfective of this verb is built by suffixation of the element /-wta/ which, in this instance, and other uses as well, renders a stative sense:

(141) mi? taaqa pakiwta

(that man enter(IMPERF))

'The man is entered (i.e. the man is inside).'

In addition to the aspectual distinction just described, Hopi possesses a two-way tense distinction. The Hopi temporal opposition is future/non-future--the first being marked in an entirely straightforward manner by the suffix /-ni/, amply illustrated in earlier sections (e.g. (2) in section 1.2.). The non-future tense is simply unmarked. Both tenses combine with each of the two aspects. Perfective and imperfective non-future are exemplified by (138-139) above, for example, and the corresponding futures are illustrated in (142-143) below:

(142) mi? taaqa wari-k-ni

(that man run(PERF)-k-FUT)

'The man will run.'

- (143) mi? taaqa wari-ki-wta-ni  
 (that man run-ki-IMPERF-FUT)  
 'The man will be running.'

Certain minor morphological peculiarities associated with suffixation of the future ending--and other endings as well--have been mentioned in passing in earlier sections of this work. For convenience, we will briefly recapitulate here the essential facts. From the point of view of suffixation, verbal bases can be divided into three classes: (a) bases which retain their final vowel, (b) bases which delete their final vowel, and (c) bases which are extended by the incremental element /-ki-/ [-ki-~-k-]. We may refer to these as, respectively, unaltering, truncating, and k-verbs. As can be readily seen, the perfective verb in (142) is a k-verb. The perfective verb of (137), by contrast, is an unaltering verbal base--hence, its future form is simply /paki-ni/ 'will enter'. The class of truncating verbs is amply illustrated in Chapter 1--it includes, for example, /nöösa/ 'to eat (non-plural subject)', whose future form is [nös-ni].

In concluding this section, we will mention briefly the nomic or usitative aspect which, like the future, is formed by straightforward suffixation. The suffix is /-ŋ<sup>w</sup>i/, and it is used to denote habitual action or general truths. The

nomic or usitative forms corresponding to (138) and (139) are given as (144-145) below:

(144) mi? taaqa wari-k-ŋ<sup>w</sup>i  
 (that man run(IMPERF)-k-USI)  
 'The man usually runs.'

(145) mi? taaqa wari-ki-wta-ŋ<sup>w</sup>i  
 (that man run-ki-IMPERF-USI)  
 'The man is usually running.'

#### 2.6.0. Remarks on Sentence Types in Hopi

For the most part, sentences which we have used for the purposes of illustrating points of Hopi grammar have been in a neutral, or declarative, form. For the sake of completeness, we mention briefly certain other sentence types in the following subsections.

##### 2.6.1. Negation

Negation in Hopi is extremely simple, from a formal point of view, since it merely involves the use of the negative particle /qa/ in some pre-verbal position, as in,

(146) (a) pam qa hohonaqa

(he NEG play)

'He is not playing.'

(b) mi? wi?ti qa yi?a?ata

(that woman NEG speak)

'That woman is not speaking.'

(c) mima totimho?yam qa took<sup>y</sup>a

(those boy(NSG) NEG sleep)

'Those boys are not sleeping.'

While this particle is consistently pre-verbal, its relative position with respect to noun phrase arguments is variable. And there is a semantic difference correlated with this variability. Thus, when /qa/ precedes just the verb phrase--as above--its scope embraces just the verb phrase. When it precedes the subject, however, as in (147) below, it is possible for its scope to embrace just the subject. The effect in this case is similar to that of the negated cleft sentence in English:

(147) (a) qa pam hohonaqa

'It's not him who is playing.'

(b) qa mi? wi?ti yi?a?ata

'It's not that woman who is speaking.'

(c) qa mima totimho?yam took<sup>y</sup>a

'It's not those boys who are sleeping.'

#### 2.6.2. Questions

Both content questions (148a) and polar questions (148b) are normally introduced by the question particle /ya/ in the Third Mesa dialect under discussion in this work:

(148) (a) ya hak hohonaqa

(Q who play)

'Who is playing?'

(b) ya pam hohonaqa

(Q he play)

'Is he playing?'



The answer to a polar question of the type represented by (148b) above employs one or the other of the two autonomous particles /ʔowíh/ 'yes' or /qaʔe/ 'no', with or without a repetition of the corresponding positive or negative version of the sentence which underlies the question; hence the dialogue,

(149) (a) ya pam hohonaqa

'Is he playing?'

ʔowíh, (pam hohonaqa)

'Yes, (he's playing).'

(b) ya pam hohonaqa

'Is he playing?'

qaʔe (pam qa hohonaqa)

'No, (he's not playing).'

Polar negative questions also occur. If the response is also negative, the appropriate particle is /qaʔe/, but if it is positive, the particle is /ʔasʔa/:

(150) (a) ya ?im qa yi?a?ata

(Q you NEG speak)

'Aren't you speaking?'

qa?e, (ni? qa yi?a?ata)

'No, (I'm not speaking).'

(b) ya ?im qa yi?a?ata

'Aren't you speaking?'

?as?a, (ni? yi?a?ata)

'Yes, (I'm speaking).'

In forming content questions, the question word is optionally advanced to the front of the sentence--directly following the interrogative particle /ya/:

(151) (a) ya ?im haki-y wiva?ta

(Q you who-OBL hit)

(b) ya haki-y ?im wiva?ta

(Q who-OBL you hit)

'Whom did you hit?'

The indefinite reading is also available in (151a) above--  
i.e. 'Did you hit someone?'

### 2.6.3. Imperatives

For positive imperatives, there exists a special form of the verb. Unaltering and truncating verbs form their imperatives by repeating the final vowel, with an intervening glottal stop:

(152) <u>Unaltering</u>		<u>Truncating</u>	
niina?a	'kill'	soma?a	'die'
tiiva?a	'throw'	caama?a	'take out'
kiiki?i	'bite'	?aasi?i	'wash hair'

But k-verbs, on the other hand, add the sequence /-i?i/ to the /k/ element:

(153) k-Verbs

wari-kiʔi	'run'
waʔökiʔi	'lie down'
yamakiʔi	'exit'

The imperative ending (i.e. /vʔv/ sequence) appears in the same relative order position within the verb word as does the future tense ending /-ni/. Thus, for example, if the imperative is formed on a verb word containing the plural suffix /-ya/, the imperative ending is realized as a doubling of the vowel of that suffix:

(154)	niina-ya-ʔa
	tiiva-ya-ʔa
	kiiki-ya-ʔa

Thus, one could think of the imperative ending as being added to the /-ya/ suffix just as the future suffix /-ni/ is added to the right of /-ya/ in forming a verb word like,

niina-ya-ni

In a positive imperative sentence, the second person subject is obligatorily deleted:

- (155)(a) taavo-t mi?a?a!  
 (rabbit-OBL shoot:IMPER)  
 'Shoot the rabbit!'

- (b) \*?im taavo-t mi?a?a!

Negative imperatives do not exist as a separate sentence type--the negative future is used instead. The second person subject does not delete in this instance:

- (156) ?im qa pi-t wiva?ta-ni  
 (you NEG him-OBL hit-FUT)  
 'Don't hit him.'

#### 2.6.4. Particles

Hopi abounds in the category traditionally referred to by the term particles. Some particles evidently have sentential scope, for example, the interrogative /-ya/ exemplified

above. Other particles appear to have a narrower scope, ranging over the verb phrase--for example, the particle /ʔas/ discussed by Voegelin and Voegelin (1969) and exemplified in sentence (45) of Chapter 4 below.

#### 2.7.0. An Introduction to Subordination in Hopi

There exist at least two sorts of clause subordination in Hopi. One of these, nominalization, will be dealt with at considerable length in the next chapter. The other, which might be termed "adjunction" fulfills a variety of functions in Hopi--conditionals, desentential adverbial expressions, and the semantic "coordination" of propositions are all expressed by the adjoined clause. In phrase markers, we will use the temporary label ADV(erbial) for these adjoined subordinate clauses, deferring the question of their proper status in phrase structure to the final chapter.

These subordination types are briefly introduced here in order to illustrate the fact that the phenomenon of obviation, discussed in earlier sections of this chapter, is also reflected in them.

#### 2.7.1. Adjoined Clauses

Adjoined clauses are marked by means of endings which indicate whether or not the subordinate subject and main-clause subject are coreferential. It is to this phenomenon

that the term "obviation" has been traditionally applied within Uto-Aztecan linguistics (cf. Grimes 1967, Hale 1969, fn. 3, Voegelin and Voegelin 1975). Thus, consider the following sentences, of which (157a) represents the proximate (PROX) situation--i.e. necessary coreference between the subjects--while (157b) represents the obviative (OBV) situation--i.e. necessary disjoint reference between the subjects:

(157)(a) ?i-pava paki-t (pii?) pam qatipti  
 (my-brother enter-PROX (then) he sat:down)  
 'When my brother<sub>i</sub> came in, he<sub>i</sub> sat down.'

(b) ?i-pava paki-q (pii?) pam qatipti  
 (my-brother enter-OBV (then) he sat:down)  
 'When my brother<sub>i</sub> came in, he<sub>j</sub> sat down.'

The proximate ending in (157a) is /-ti/ [-t], and the obviative ending of (157b) /-qö/ [-q]. The latter is the sole obviative ending for adjoined clauses in Hopi. But the proximate system for adjoined dependent clauses is somewhat richer. The inventory of proximate endings includes not only the successive proximate suffix /-ti/ [-t], but also the concursive /-k<sup>y</sup>ana/ [-k<sup>y</sup>an] (pl. /k<sup>y</sup>aak<sup>y</sup>ana/ [-k<sup>y</sup>aak<sup>y</sup>an]) 'while', the

conditional /-eʔe/ [-eʔ] 'if', and the causal or resultative ending /-qaʔe/ [-qa~-qe] 'because'.

The status of these endings in Hopi grammar, and the manner in which they are introduced into Hopi phrase structure will be dealt with briefly in Chapter 4 below.

### 2.7.2. Nominalizations

Nominalized sentences are marked by means of the element /-qa/ suffixed to the subordinate verb, as in

- (158)      miʔ    tiyoʔya ʔacata-qa pakmimiya  
               (that boy      lie-qa      cry)  
               'The boy that lied is crying.'

Nominalizations serve as the relative clause and also desentential nominal complements. The relative clause will be discussed at length in the next chapter.

Under certain conditions, nominalized sentences are marked for case, Voegelin and Voegelin (1975) point out, correctly, that the alternation between the [-t] and [-y] alternants is governed by the principle of obviation in the case of nominalizations appearing in object position. This is illustrated in the following:



(159)(a) ni? taavo-t mi?a-ni-qa-y naawakna  
 (I rabbit-OBL kill-FUT-qa-OBL(PROX) want)  
 'I want to kill a rabbit.'

(b) ni? Po?k<sup>y</sup>aya taavo-t mi?a-ni-qa-t  
 (I Po?k<sup>y</sup>aya rabbit-OBL kill-FUT-qa-OBL(OBV)  
 naawakna  
 want)  
 'I want Po?k<sup>y</sup>aya to kill a rabbit.'

The [-y] alternate marks the proximate situation, while the [-t] alternate marks the obviative situation. In the following chapter, it will be shown that this observation of the Voegelins has a parallel in the case of nominalizations appearing in subject position as well.

## FOOTNOTES TO CHAPTER 2

1. (a) Some dialects do not make the distinction between animate-inanimate for duality feature.  
(b) /-viti/ is the form of the dual suffix on Second Mesa.
  
2. The prefixed form of the postpositional phrase here is actually the incorporated /kii-ve/. For other examples of incorporation see (93) and (95) below.

## CHAPTER 3

## THE RELATIVE CLAUSE

3.0. Introduction

In our initial investigation of relative clauses (Masayesva-Jeanne, 1974), we discovered that there is an apparent constraint on the use of the Hopi complex noun phrase structure which functions as the relative clause. The structure can be used freely in constructing sentences corresponding to the English sentences of (1):

- (1) (a) I saw the boy whom the dog bit.  
(b) I know the woman you were speaking to.  
(c) I know the woman John works with.

However, it cannot, without recourse to periphrasis, be used to construct sentences corresponding to the English sentences of (2):

- (2) (a) The boy whom the donkey threw died.  
(b) The woman you were speaking to went home.

(c) The woman John works with speaks good Hopi.

The point is this. When the complex noun phrase, as a whole, functions as the subject of the main clause, the "relative noun phrase" (i.e. that noun phrase in the subordinate clause which is coreferential with the complex noun phrase) must likewise function as the subject within its own clause. Hence, the Subject Constraint:

(3) The Subject Constraint

If the head of a relative clause functions as the subject in the main clause, then only the subject in the embedded clause may be relativized.

There is no constraint, however, when the complex noun phrase is a non-subject within the main clause. Thus, it would appear that Hopi imposes a curious limitation on the accessibility of noun phrases to relativization (cf. Keenan and Comrie, 1972)--when the complex noun phrase is itself a subject, relativization is limited to subjects, otherwise not. This is a rather curious picture and is not at all like NP

accessibility limitations observed in other languages of the world, since it is tied to the grammatical relation which the complex noun phrase bears to the main verb, rather than solely to that which the relative noun phrase bears to the verb of the subordinate clause.

Several questions arise: (1) Is the Subject Constraint necessary in Hopi?, (2) Why should something like the Subject Constraint exist in Hopi?, and, (3) What are the other Hopi facts that relate to the existence of the constraint?

In this chapter we will attempt to find answers to the questions posed above. We begin with a brief description of the Hopi relative clause structure.

### 3.1. The Formation of Relative Clauses

Before we look at the data revealing the Subject Constraint, as a necessary first step, we explain what a relative clause is and how it might be formed. Consider the following simplex sentences:

- (4) ni? tiyo?ya-t hoona  
 (I boy-OBL sent:home)  
 'I sent home the boy.'

with a phrase marker

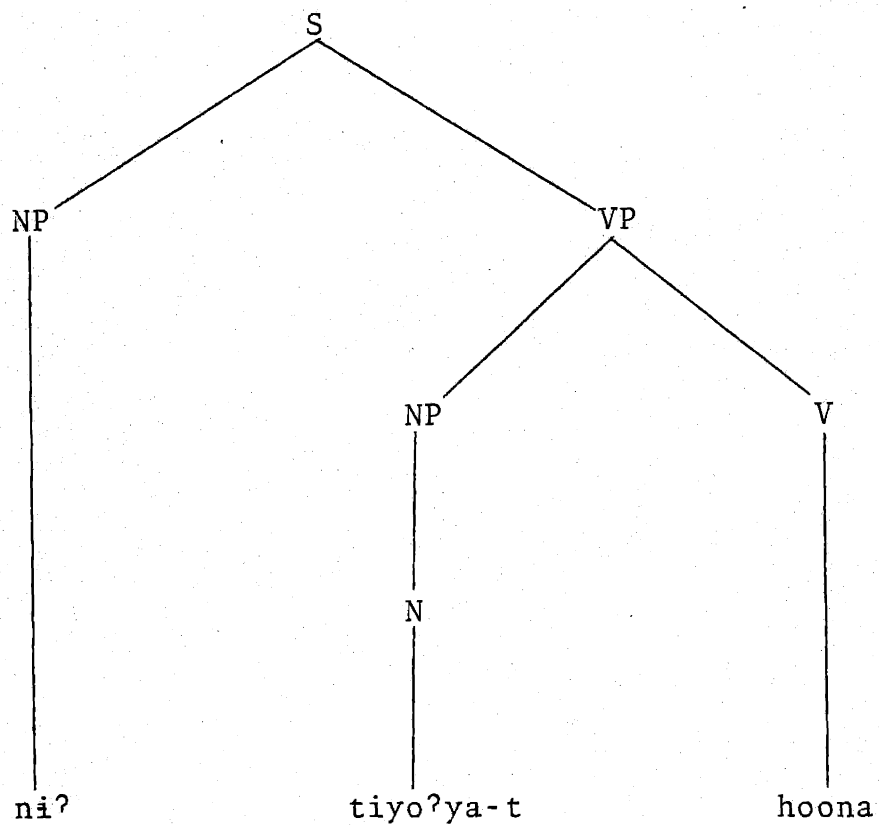

and,

- (5) tiyo?ya pakimiya  
 (boy cry)  
 'The boy is crying.'

with the phrase marker

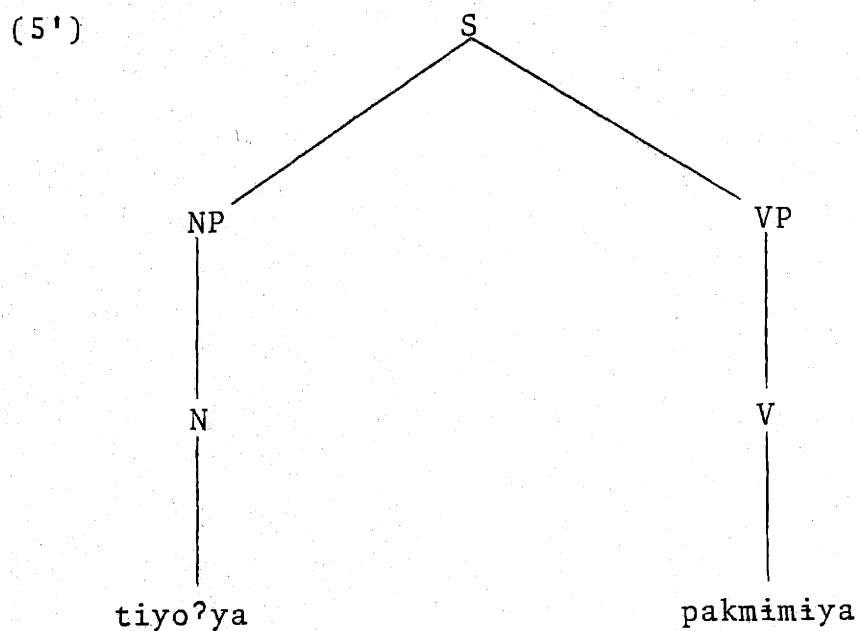

Embedding (5) in (4) gives a relative clause structure, that is,

- (6) ni? tiyo?ya-t pam pakmimiy-qa-t hoona  
 (I boy-OBL he cry-REL-OBL sent:home)  
 'I sent home the boy that is crying.'

which we assume, tentatively, has the following phrase marker:

(6')

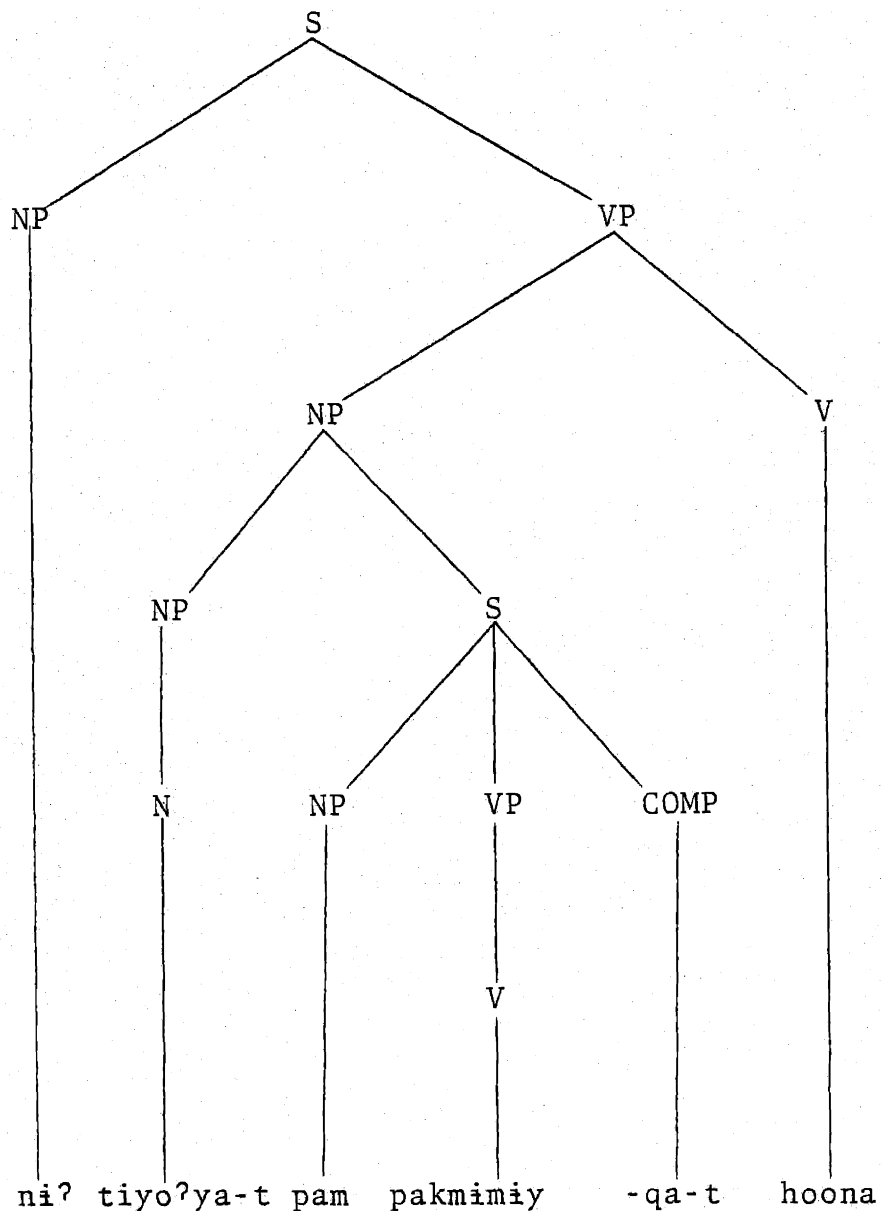

From (6) we make the following observations. First, the relativizing 'complementizer' is /-qa/, and it is affixed to the embedded verb (presumably the phonological shape of the sequence verb + /-qa/ is governed by the same phonological



principles involved in suffix attachment--e.g. 1.1. above). Second, apparently, the /-t/ that appears on /tiyo<sup>?</sup>ya/ [tiyo<sup>?</sup>ya-t] and on the relative clause as a whole is the oblique case ending (presumably it gets there by regular case marking (see section 2.2.) but see also below for special provision). Third, the shared NP--e.g. /tiyo<sup>?</sup>ya/ is realized as /pam/ in the relative clause. As to whether the pronoun is derived by some kind of pronominalization rule or whether it is in the base to begin with, this remains an open question. In any case, it is not relevant to our discussion here. For the purposes of our discussion, we assume the latter. Finally, the pronoun /pam/ in (6) can be deleted, giving, still a grammatical sentence,

- (7) ni<sup>?</sup> tiyo<sup>?</sup>ya-t [pakmimiy-qa-t] hoona  
 (I boy-OBL cry-REL-OBL sent:home)  
 'I sent home the boy that is crying.'

The deletion is optional--we make use of ( ) around a shared NP to indicate its optionality.

We employ the following structure to define certain terms which will occur in the course of our discussion:

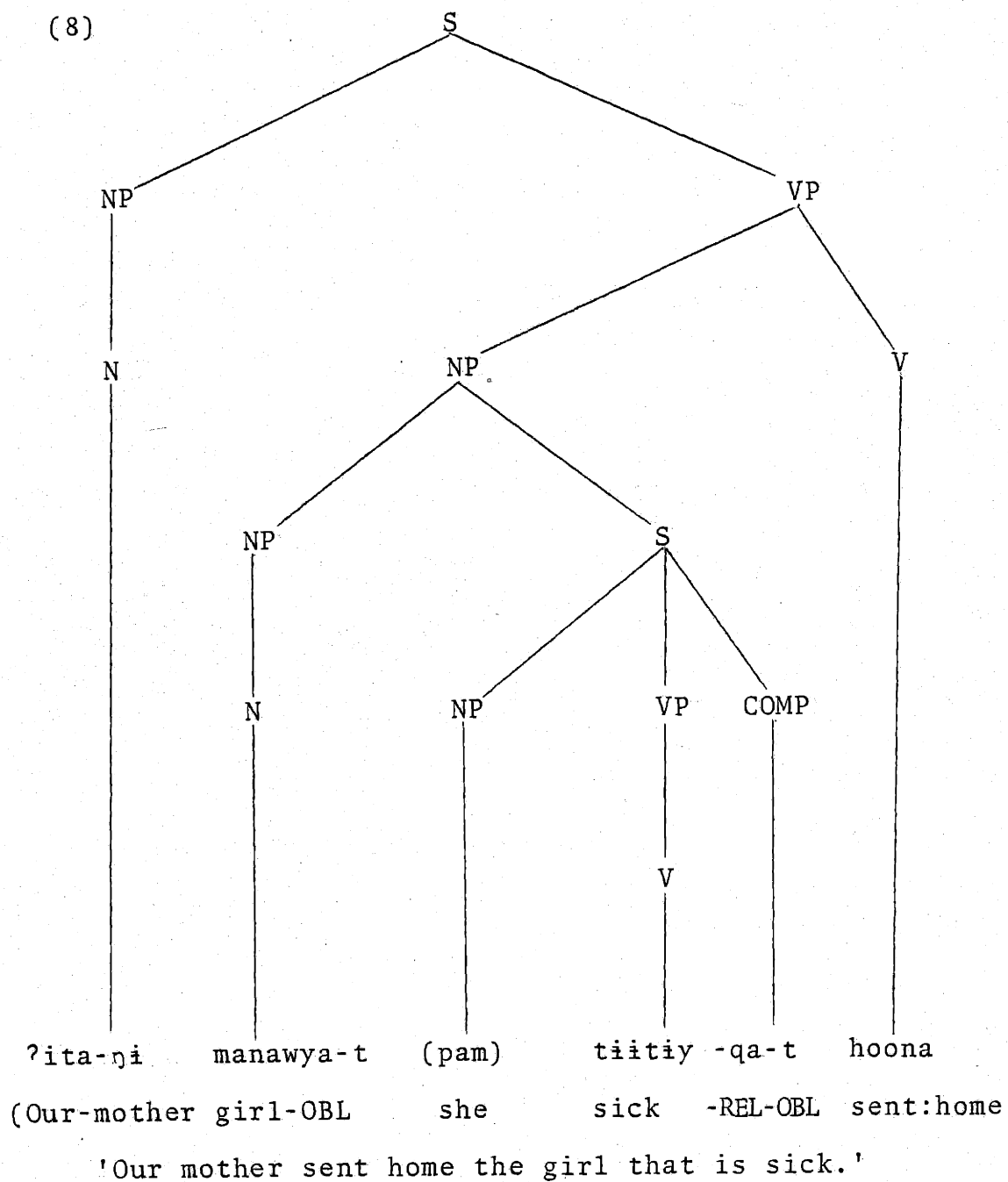

We will refer to /manawya-t/ as the "head NP" of the relative structure; the NP containing the pronoun /pam/ we will refer

to as the "relative NP".

The phrase markers given for the sentences (6) and (8) are approximations and will be refined in later sections. Also, we have no motivation for having a complementizer node (COMP) or for having it daughter-adjoined to the lower S. In a later chapter, we will in fact state specifically what the relativizing complementizer is and where it must be attached. We assume the above structures, for the time being, merely to facilitate the discussion.

### 3.2.0. Data Revealing the Subject Constraint

We now look at the data revealing the Subject Constraint. When a relative clause modifies a non-subject NP of the matrix clause, the relativized noun phrase within the relative clause can occupy a variety of syntactic positions. Thus, for example, relativization is possible when the relativized noun phrase is,

- (a) the subject in the embedded sentence
- (b) the object of a transitive verb in the embedded sentence
- (c) the object of a postposition in a postpositional phrase in the embedded sentence.

The Hopi sentences representative of (a-c) are the following:

- (9) (a) ni? tiyo?ya-t [(pam) pakmimiy-qa-t] hoona  
 (I boy-OBL (he) cry-REL-OBL sent:home  
 'I sent home the boy that is crying.'
- (b) ni? tiyo?ya-t [ʔita-ŋi (pi-t) naawakna-qa-t]  
 (I boy-OBL our-mother him-OBL like-REL-OBL  
 tiwi?yta  
 know)  
 'I know the boy that my mother likes.'
- (c) ni? tiyo?ya-t [ʔita-na (pi-t) ʔa-mim  
 (I boy-OBL our-father him-OBL him-with  
 timala?yta-qat] tiwi?yta  
 work-REL-OBL know)  
 'I know the boy who my father works with.'

There is, however, an apparent limitation on relativization when the complex noun phrase function as subject in the main clause, that is, where the structure is roughly,

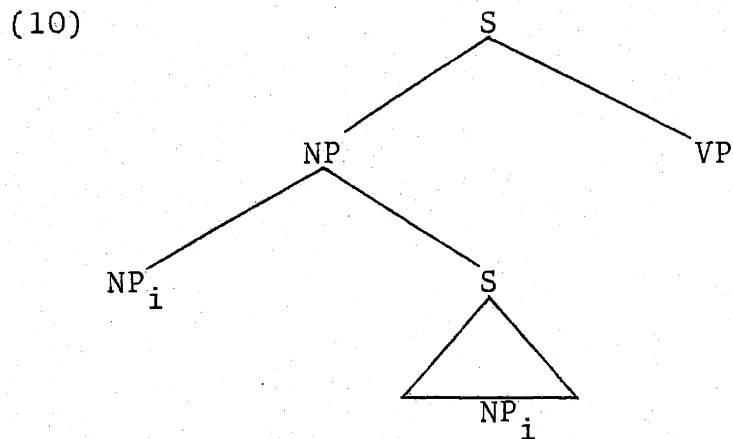

Given a structure of the form represented in (10), relativization is possible if the relative noun phrase of the relative clause is another subject, as in,

(11) mi? tiyo?ya [(pam) ?acata-qa] pakmimiya  
 (that boy (he) lie-REL cry)  
 'The boy that lied is crying.'

(12) mi? tiyo?ya [(pam) Po?k<sup>y</sup>aya-t wiva?ta-qa]  
 (that boy (he) Po?k<sup>y</sup>aya-OBL hit-REL  
 waaya  
 ran:away)  
 'The boy that hit Po?k<sup>y</sup>aya ran away.'

- (13) mi? tiyo?ya [(pam) ?ita?-so-y  
 (that boy (he) our-grandmother-OBL  
 moosa-y-at ta?tiva-qa pakmimiya  
 cat-OBL-her hit-REL cry)  
 'The boy that hit our grandmother's cat is crying.'

Attempts to relativize noun phrases in syntactic positions other than non-subject produces ungrammatical sentences as seen in the examples following:

- (14)\*mi? tiyo?ya [ni? (pi-t wiva?ta-qa] pakmimiya  
 (that boy I him-OBL hit-REL cry)  
 'The boy that I hit is crying.'
- (15)\*mi? tiyo?ya [ni? (pi-t ?a-mim timala?yta-qa]  
 (that boy I him-OBL him-with work-REL  
 nima  
 went:home)  
 'The boy that I work with went home.'

- (16) \*mi? tiyo?ya [ni? (pi-t) moosa-y-at ta?tiva-qa]  
 (that boy I him-OBL cat-OBL-his hit-REL  
 pakmimiya  
 cry)  
 'The boy whose cat I hit is crying.'

Notice in the examples (11-16) above that the oblique case marker /-t/ does not appear on the head noun or the relative clause, presumably since the whole complex noun phrase here functions as a subject. We will see, however, that this assumption, which was fundamental to our initial conception of Hopi relative-clause formation, is in error.

### 3.2.1. The Subject Constraint

The examples of (14-16) led us to postulate the Subject Constraint on relativization; repeated here as (17).

#### (17) The Subject Constraint

If the head of a relative clause functions as the subject in a matrix clause, then only a subject in the subordinate clause can be relativized.

That the constraint must make crucial reference to the notion 'subject' and not, say, to the notion 'first noun phrase in linear order' is shown by the following sentence with its phrase marker:

(18) mi-t            tiyo?ya-t [ni? (pi-t)    tiwi?yta-qa-t]

(that-OBL boy-OBL    I    him-OBL know-REL-OBL

po?ko-?at mooki

dog-his    die)

LIT: 'The boy that I know's dog died.'

e.g. 'The dog of the boy that I know died.'



(18')

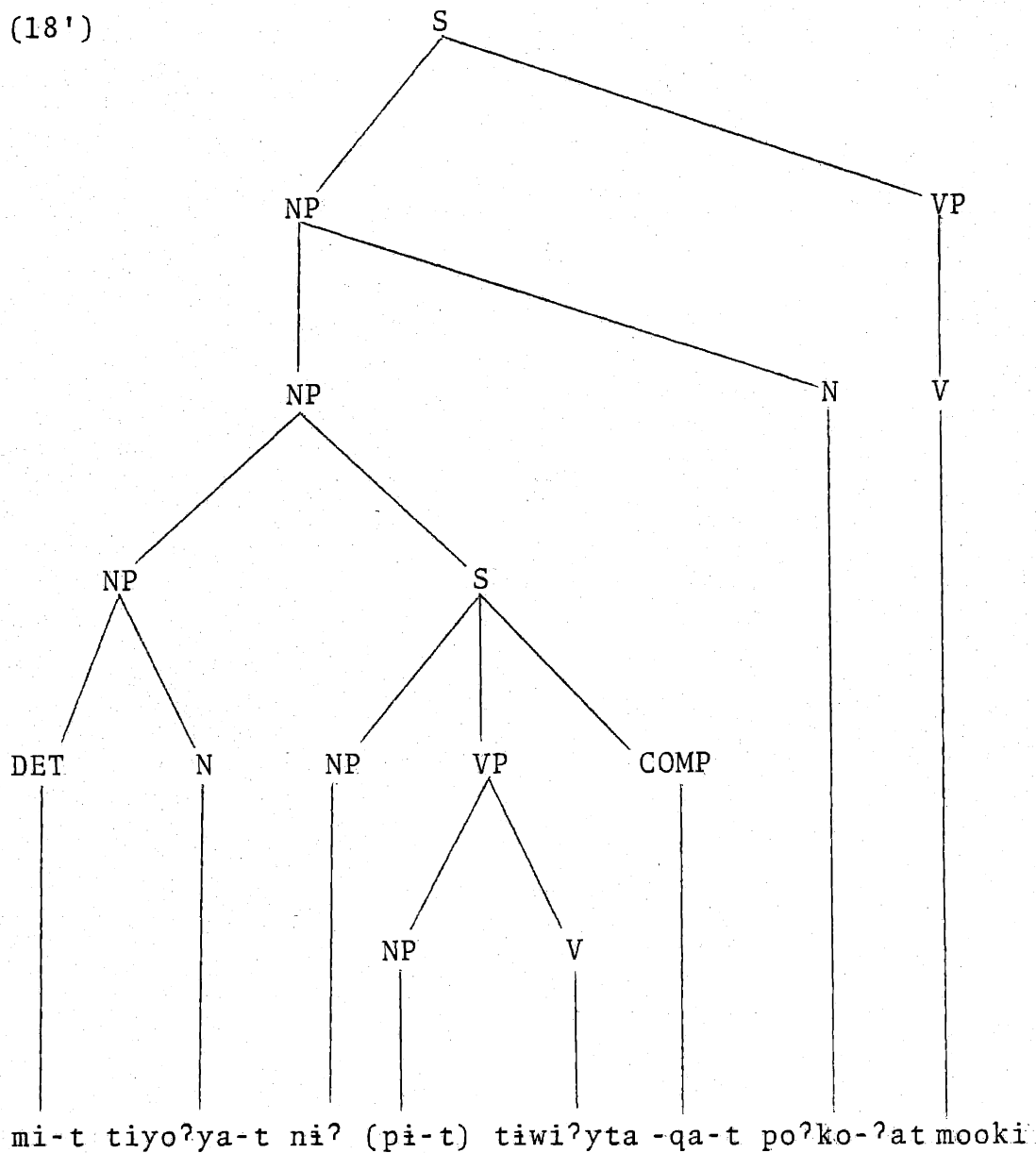

Although the head of the relative clause /mi? tiyo?yat/ is the first noun phrase in linear order, it is not the subject of the sentence (which, in this case, is /po?ko?at/ or, rather, the entire complex NP headed by /po?ko?at/), hence the Subject

Constraint is not applicable to (18).

Having introduced the reader to the Hopi relative clause construction and to the Hopi data revealing the Subject Constraint, we offer now several competing theories of relativization in Hopi. Each theory will attempt to explain this so-called Subject Constraint according to what is allowed in that particular theory. The reader should be cautioned, however, that the exact details of one theory vs. another have not been worked out entirely.

3.3.0. Elementary Theory of Relative Clauses: The Headed  
Relative Clause

Recall a sentence,

(19)

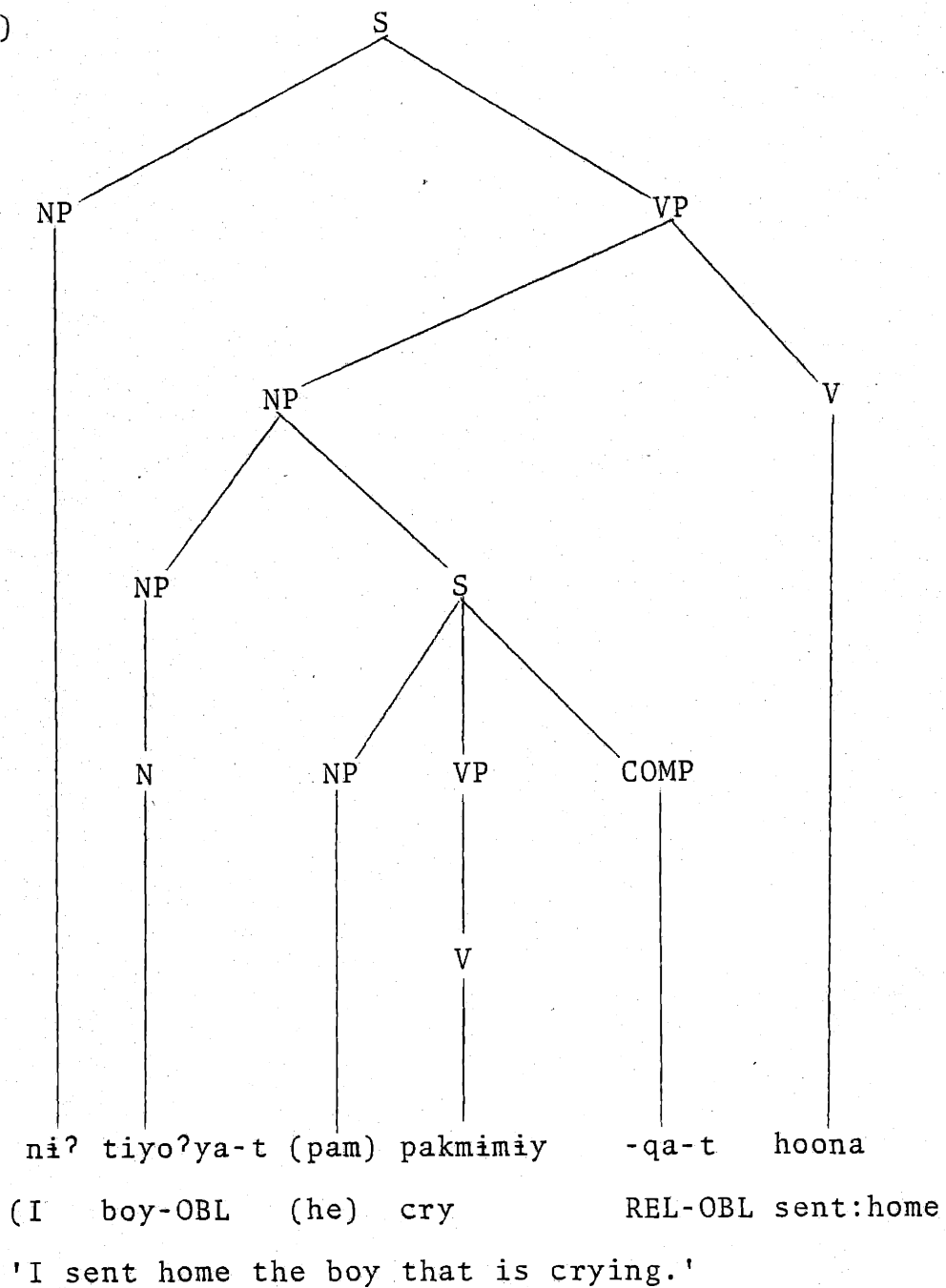

Our first theory assumes just such a structure for relative clauses. Specifically, this theory states that relative

clauses start out in the base with a head NP in underlying representation. That is, in (19) the head NP is /tiyo<sup>?</sup>yat/ and it appears outside of and to the left of the subordinate clause--in underlying representation. (Hence, we refer to this analysis as the 'headed analysis'.) It is this property of the base that will distinguish it from the next theory to be considered--the 'headless' theory.

Relativization would then proceed roughly along the lines suggested in section 3.1.. Importantly, it will, given a structure like (19), identify a head noun phrase and either through a pronominalization or construal process, associate it with a shared noun phrase.

How is the Subject Constraint handled under this theory? Given just the data thus far, this theory is forced simply to have the Subject Constraint in order to account for the ungrammatical sentences (14-16). The choices open to us, at this point, it seems, is (1) to accept the Subject Constraint as a language particular principle, and nothing more be said, or, (2) to pursue the Subject Constraint further and perhaps find out why it is a language particular thing, or, (3) pursue other alternatives which would not involve the Subject Constraint at all. Whichever we choose, it is clear that the Subject Constraint seems to be an unnatural constraint and that it should be preferable to explain it in some other terms.

3.3.1. The Headless Theory

Consider the following sentences with their phrase markers:

(20) mi-t            tiyo?ya-t [ni? (pi-t)    tiwi?yta-qa-t]

(that-OBL boy-OBL    I    him-OBL know-REL-OBL

po?ko-?at mooki

dog-his    die)

'The dog of the boy that I know died.'

(20')

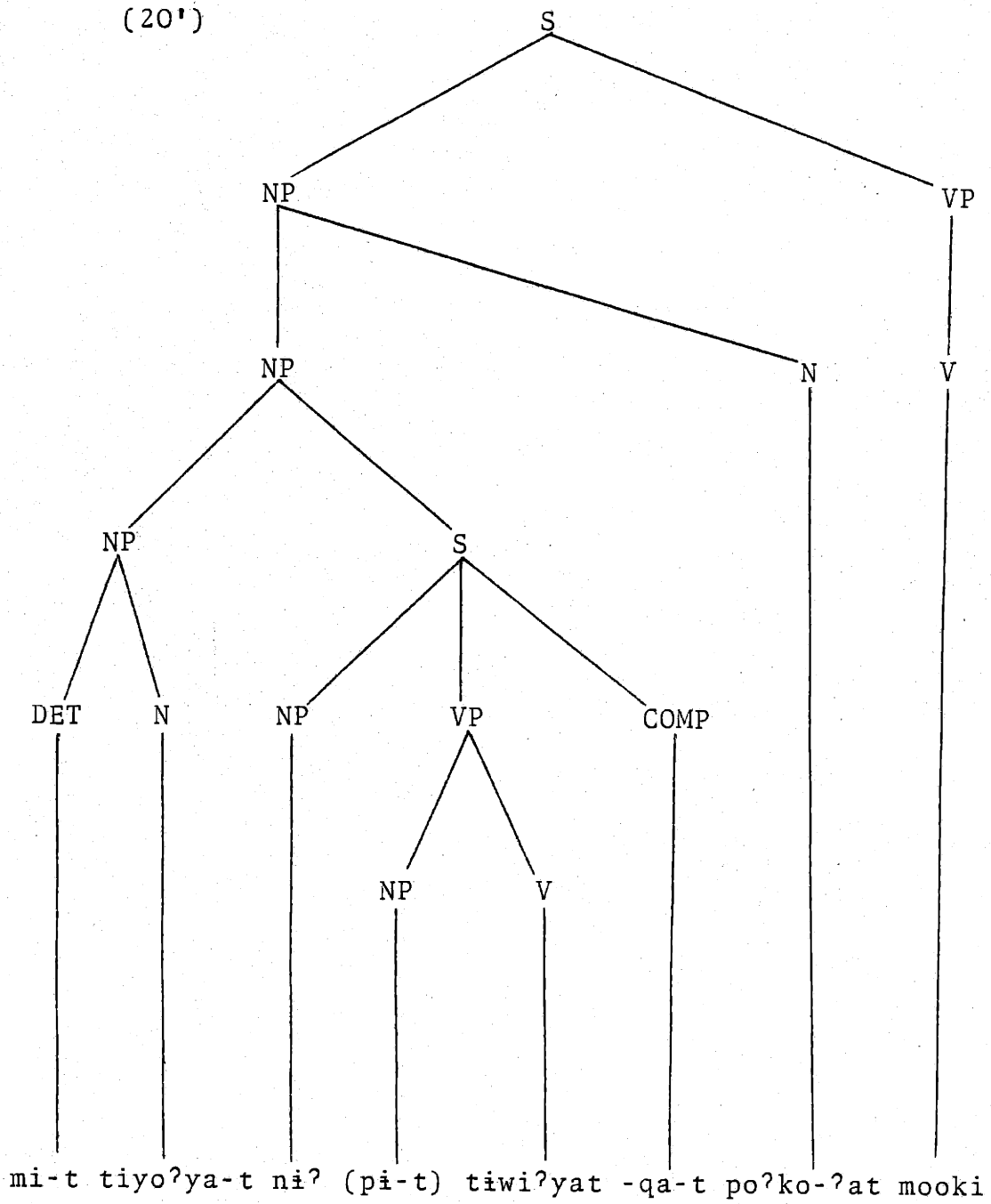

(21) [ni<sup>?</sup> mi-t tiyo<sup>?</sup>ya-t tiwi<sup>?</sup>yta-qa-t] po<sup>?</sup>ko-<sup>?</sup>at mooki

(21')

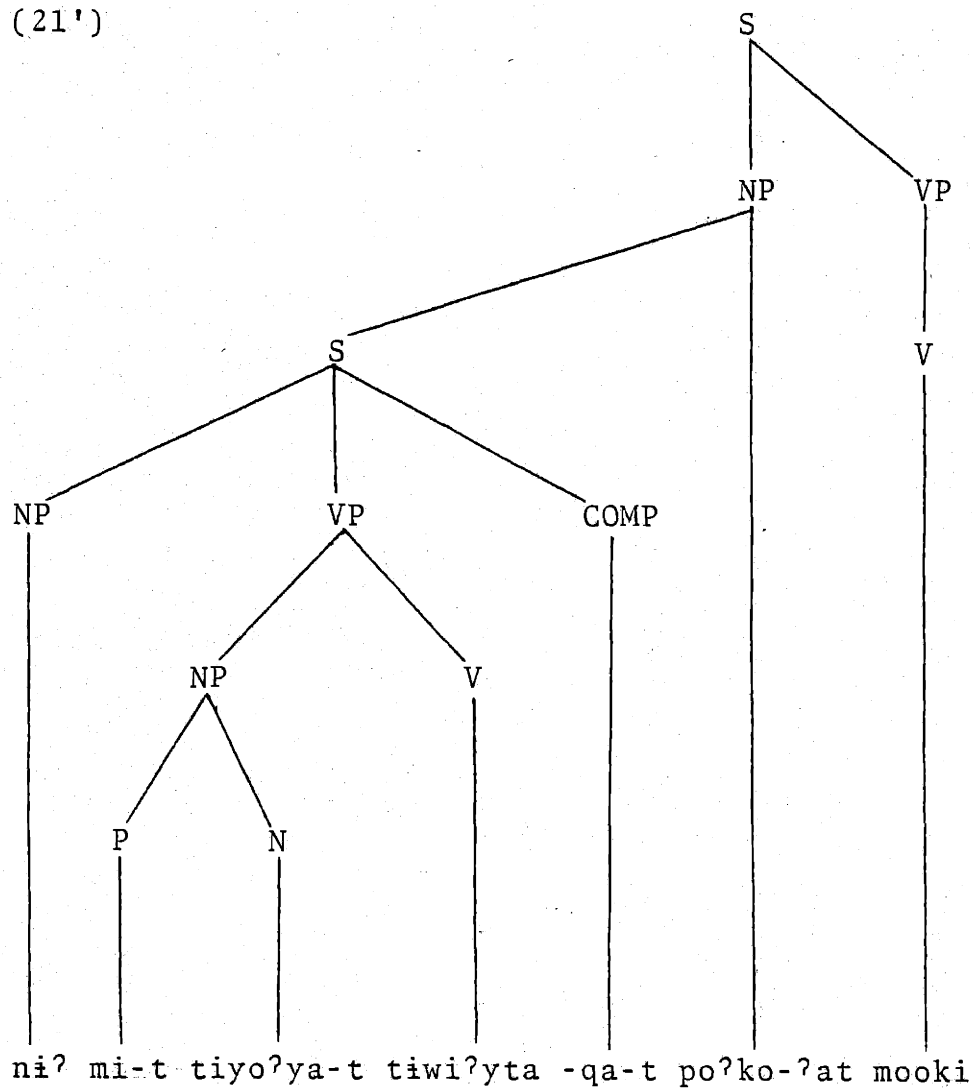

The point of interest in (20) and (21) is this. Both sentences are grammatical, and, furthermore, they are identical semantically. The difference lies in that the relative structure in (21) appears to be 'headless'--that is to say, it has

no head noun phrase.

Faced with the existence of the two types of relative clauses, one could say as an initial guess, that there are in fact two kinds of relative clauses differing only with respect to the base--one has a head noun phrase in underlying representation and the other lacks a head NP in underlying representation. This hypothesis, it seems to us, is not only uninteresting but it continues to force one to have a Subject Constraint--in which case we would have done nothing to explain the constraint.

Another interesting possibility that suggests itself is the following. Suppose the headless relative is more basic and that the headed variety is derived from the headless one by a raising rule. For example, (20) would be derived from (21) by raising the constituent /mit tiyo<sup>?</sup>yat/ into head position, leaving a pronominal copy behind. Similarly, a sentence,

(22) ni<sup>?</sup> mi-t            tiyo<sup>?</sup>ya-t [(pam) pakmimiy-qa-t]

(I    that-OBL boy-OBL        (he) cry-REL-OBL

hoona

sent:home

'I sent home the boy that is crying.'



is derived from underlying,

(23) ni? [mi? tiyo?ya pakmimiy-qa] hoona .

Also, a sentence,

(24) mi? tiyo?ya [(pam) ?acata-qa] pakmimiya

(that boy (he) lie-REL cry)

'The boy that lied is crying.'

starts out as,

(25) [mi? tiyo?ya ?acata-qa] pakmimiya .

How would the raising analysis of relative clauses account for the facts subsumed under the Subject Constraint? Suppose we assume first a rule assigning case marking to noun phrases:

(26) NP-Case Assignment

The oblique ending OBL is right daughter-adjoined to any NP node which is not dominated by an S.

We specify that this rule must be cyclical.

Given this rule of NP-Case Assignment and a raising theory of relative clauses, it would be impossible to generate ungrammatical sentences of the kind that motivated the Subject Constraint. Thus, let us consider one such ungrammatical sentence--i.e.

- (27)\*mi? tiyo?ya [pam maana (pi-t) wiva?ta-qa]  
 (that boy that girl him-OBL hit-REL  
 waaya  
 ran:away  
 'The boy whom the girl hit ran away.'

--and let us see how it could work. According to our analysis, the underlying form for (27) must be,

(28)

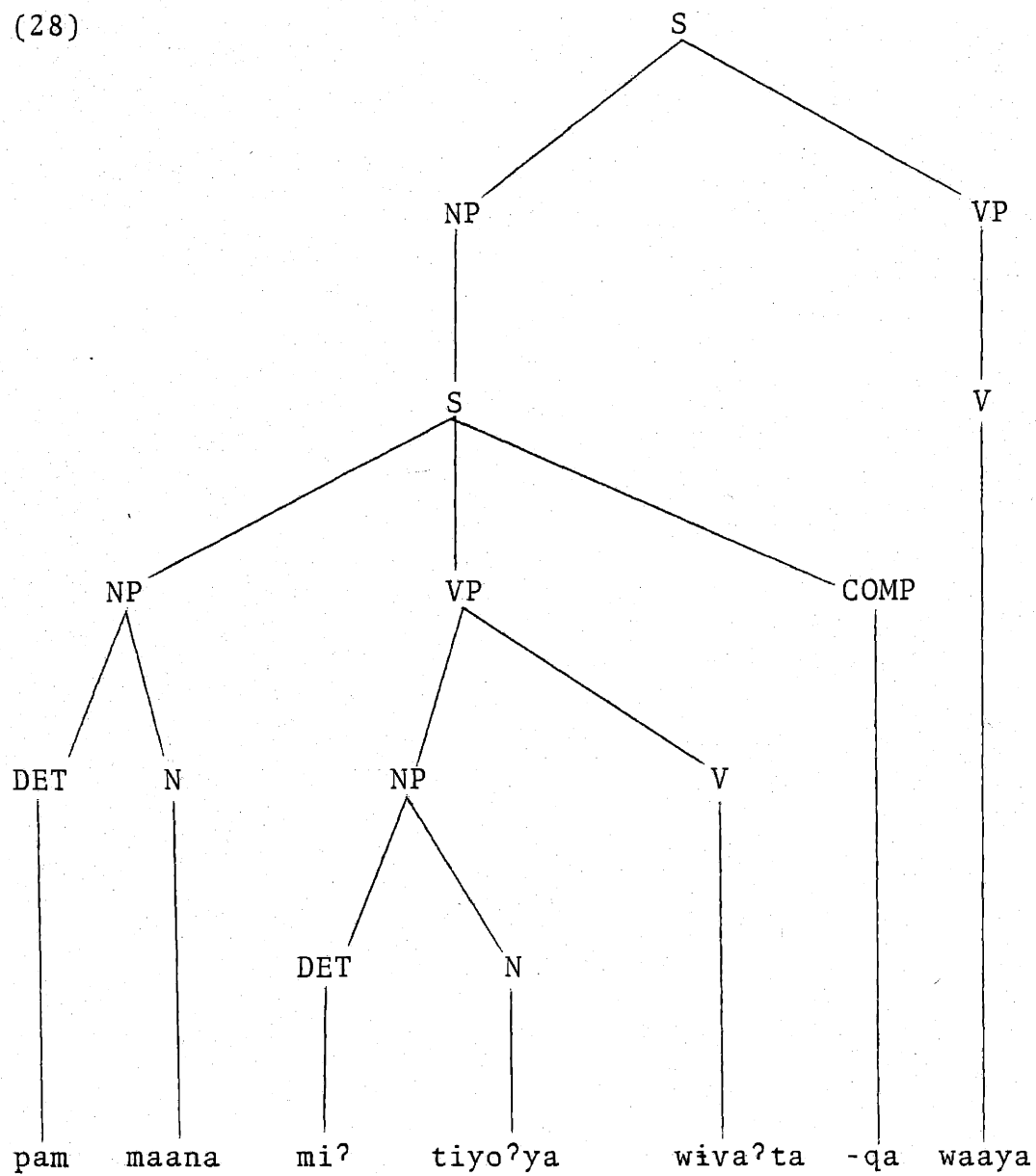

that is, where the headless structure is basic. Next, apply NP-Case Assignment marking in this structure giving,

(28')

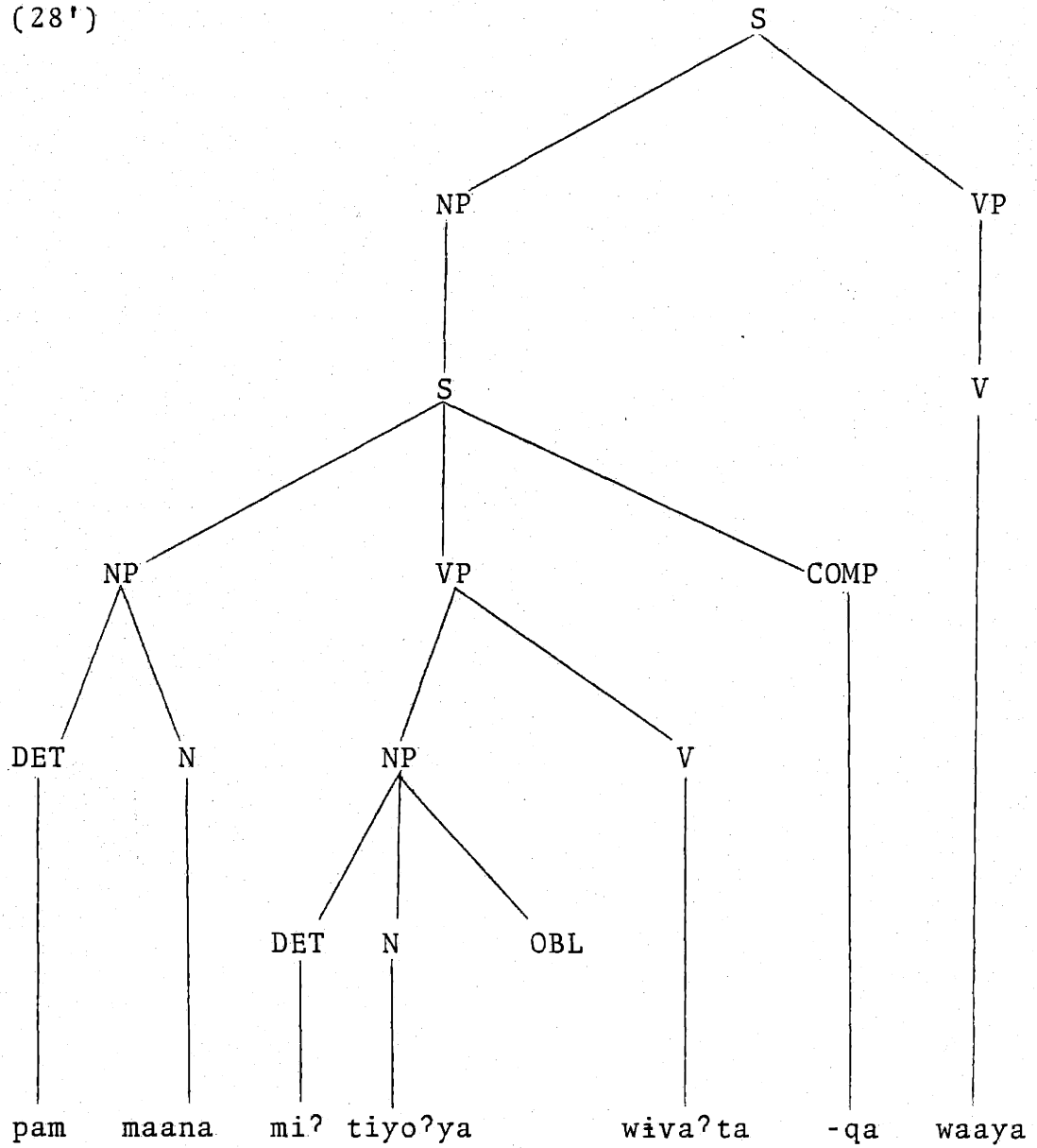

On the next cycle, raising applies, giving,

(28'')

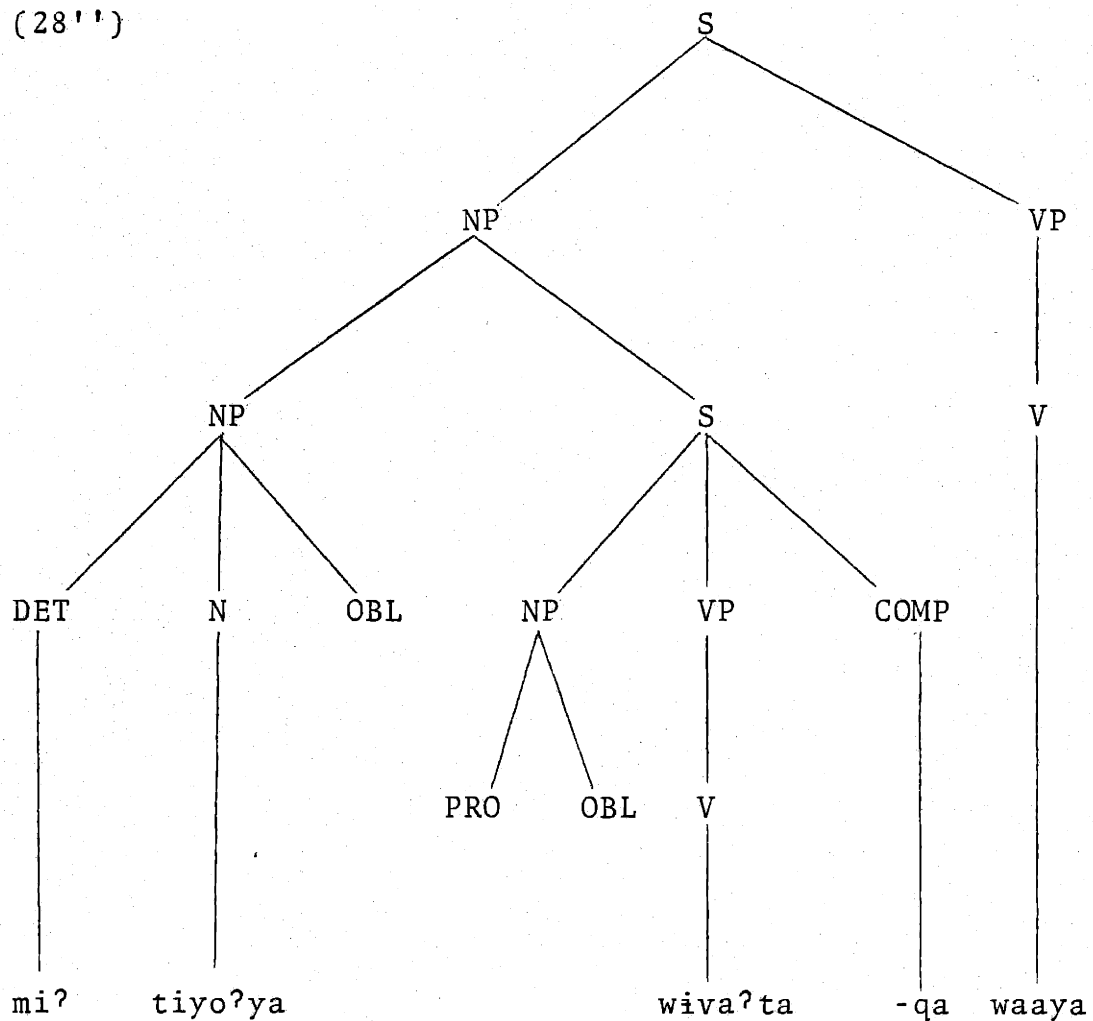

Notice that in (28'') above, the constituent /mi? tiyo?ya/ has been raised into head position, crucially with an OBL attached to it. This structure, ultimately underlies a sentence,

(29)\*mi-t tiyo?ya-t [pam maana (pi-t) wiva?ta-qa] waaya.

The point is that we can never derive the ungrammatical sentence

(27) \*mi? tiyo?ya [pam maana (pi-t) wiva?ta-qa] waaya

since the head noun phrase /mi? tiyo?ya/ would have been case-marked on an earlier cycle and could not be case marked as in (27). Instead, (29) is produced--which unfortunately is also ill-formed, but one which we deal with shortly. In this fashion, none of the ungrammatical sentences subsumed under the Subject Constraint are ever produced. In fact, under the raising analysis there is no Subject Constraint.

The raising analysis, however, poses another problem, namely, it is responsible for generating yet another set of ungrammatical sentences, such as the one given above, that is (29). How is the ill-formedness of a sentence like (29) to be accounted for in the raising analysis? The explanation rests on a rule of Case Concord which can be stated as follows:

(30) Case Concord

Given an NP of the form XAY, OBL, right daughter-adjoin the oblique ending to A,

where A is an immediate constituent of the NP, and A is not already supplied with the oblique ending.

This is a late rule and amounts essentially to a morphological readjustment; furthermore, we assume that it is motivated independently of relative clauses and that it is responsible for ensuring that both the determiner and noun are supplied with an OBL ending in a simple sentence, like,

(31) ni? mi-t      tiyo?ya-t tiwa  
 (I    that-OBL boy-OBL    see)  
 'I saw that boy.'

Now let us look again at (29), repeated here for convenience:

(29)\*mi-t tiyo?ya-t [pam maana (pi-t) wiva?taqa] waaya

Notice that the head noun phrase is marked for the oblique

case, while the relative clause, /pam maana pit wiva?taqa/ is unmarked. We propose that the ill-formedness of (29) is due to this disparity in case-marking. That is, (29) is in violation of a general principle of Hopi, according to which each immediate constituent of a noun phrase agrees in case--this principle being Case Concord.

To see how Case Concord works, consider, again, the derivation of the ungrammatical sentence (29). It will, as we indicated earlier, begin with the following structure:

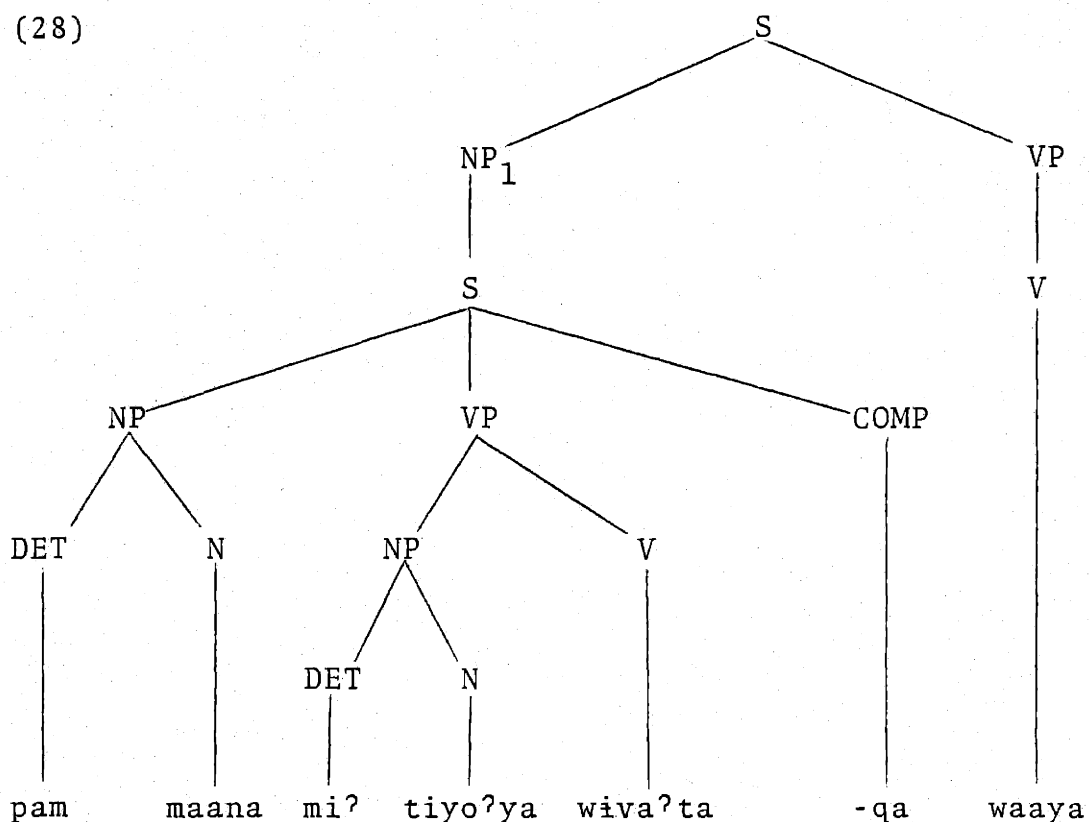



On the lower cycle, NP-Case Assignment assigns case to the object NP:

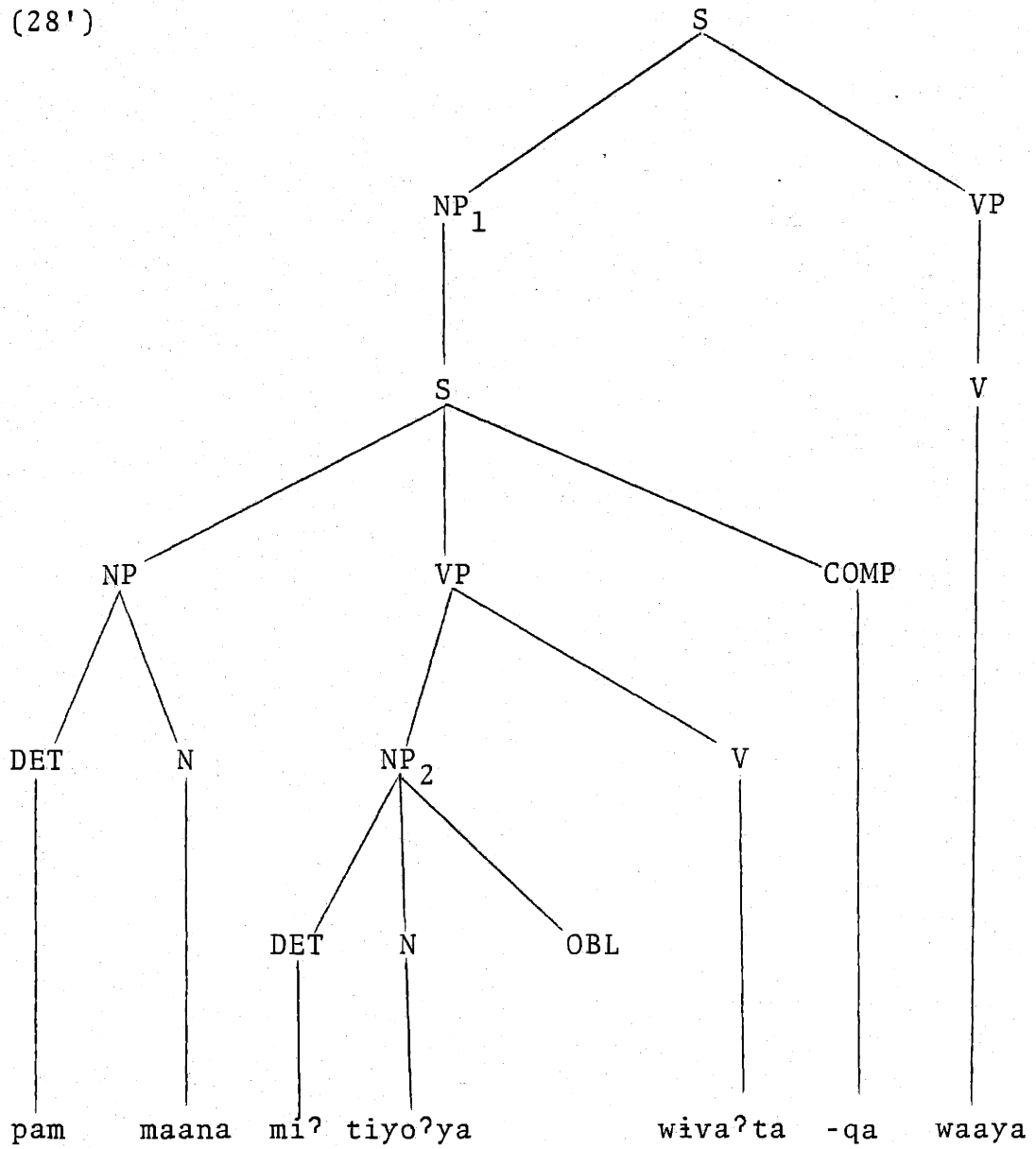

On the next cycle up, the NP/mi? tiyo?ya/ is raised to head position with an OBL attached:

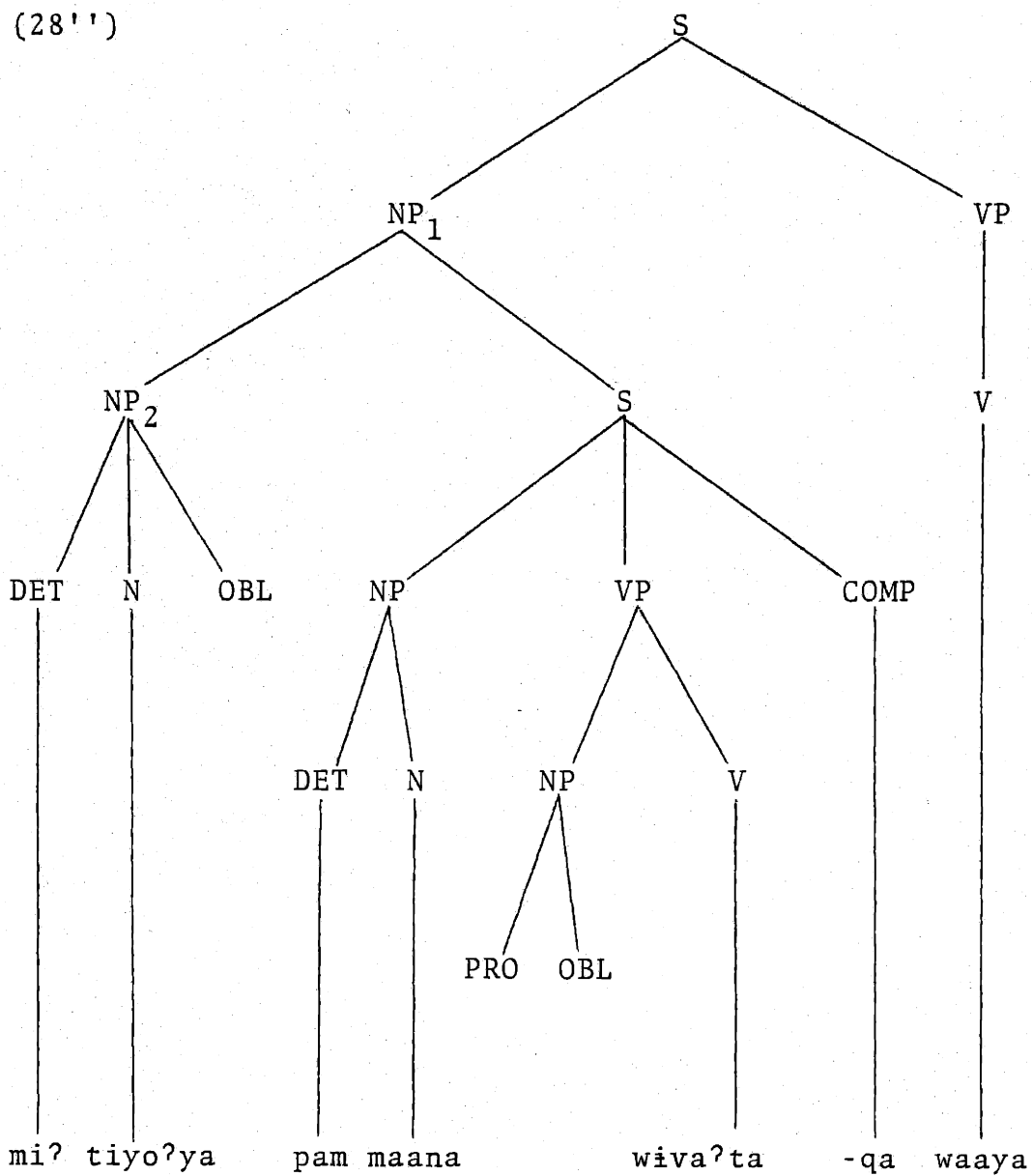

At this point, Case Concord applies to the head NP of the relative clause:

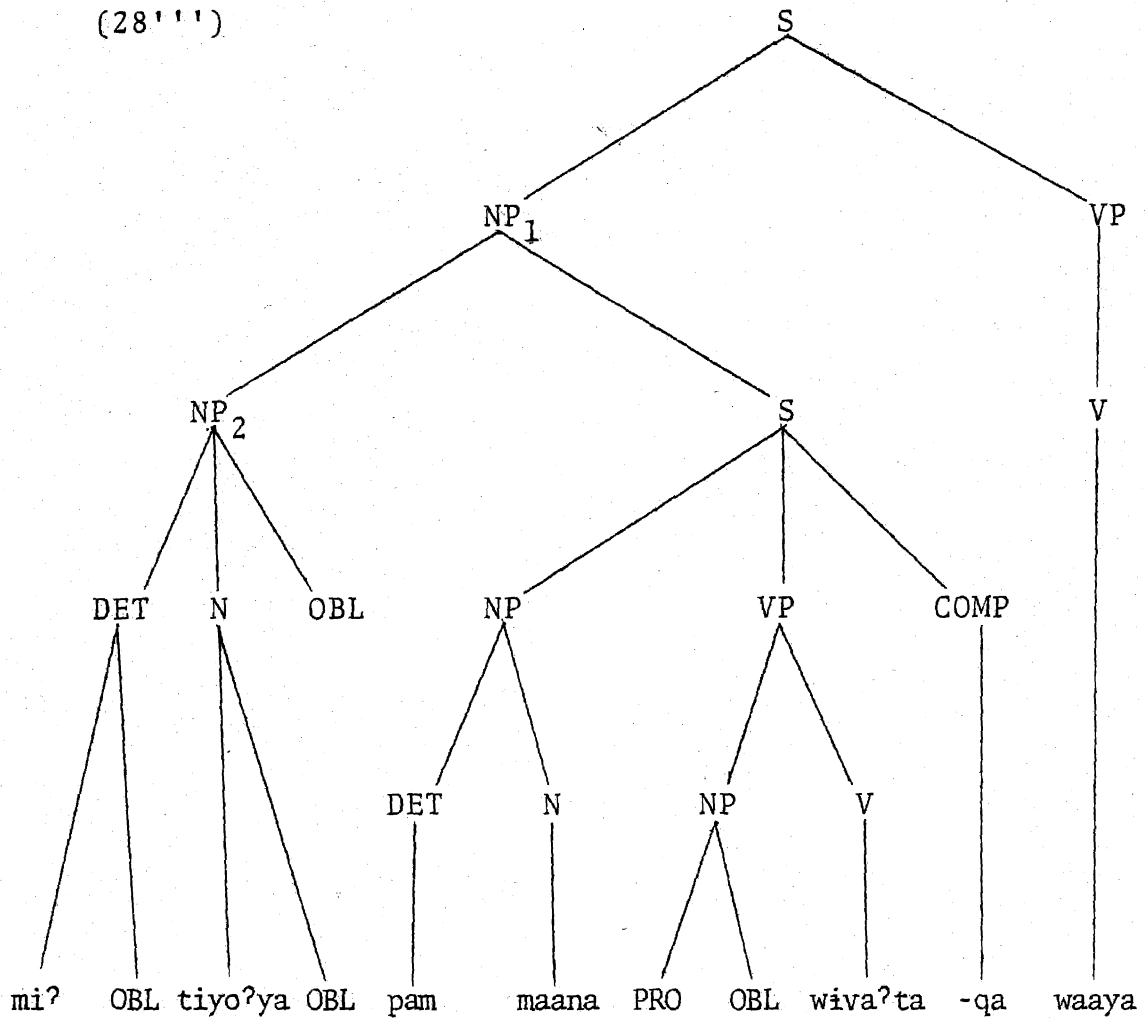

The important point is that Case Concord does not succeed in spreading the OBL ending to the relative clause itself (i.e. /-qa/ does not have OBL attached to it), since the relative

clause is not an immediate constituent of the head noun phrase (NP<sub>2</sub>), but rather is an immediate constituent of NP<sub>1</sub>. We use this as the basis to rule out the ungrammatical sentences (29) by adopting the following convention:

(32) Concord Convention

Assign \* to any NP in which some but not all of its immediate constituents are marked with the oblique ending.

Given this convention, (29) will be ruled out, since NP<sub>1</sub> has one constituent marked with OBL (namely, NP<sub>2</sub>), but its other immediate constituent (S) is not marked with OBL--hence, a violation of the Concord Convention. In this way, the raising analysis along with Case marking and Case Concord can account for the Subject Constraint facts.

Relative clauses in object position will be handled as follows on the raising analysis. Assume the sentence:

- (33) ?ita-ŋi mi-t tiyo?ya-t [ni? (pi-t)  
 (our-mother that-OBL boy-OBL I (him-OBL)  
 paklawna-qa-t] hoona  
 make cry-REL-OBL sent:home)

LIT: 'Our mother sent home the boy that I made cry.'

which is derived from a source,

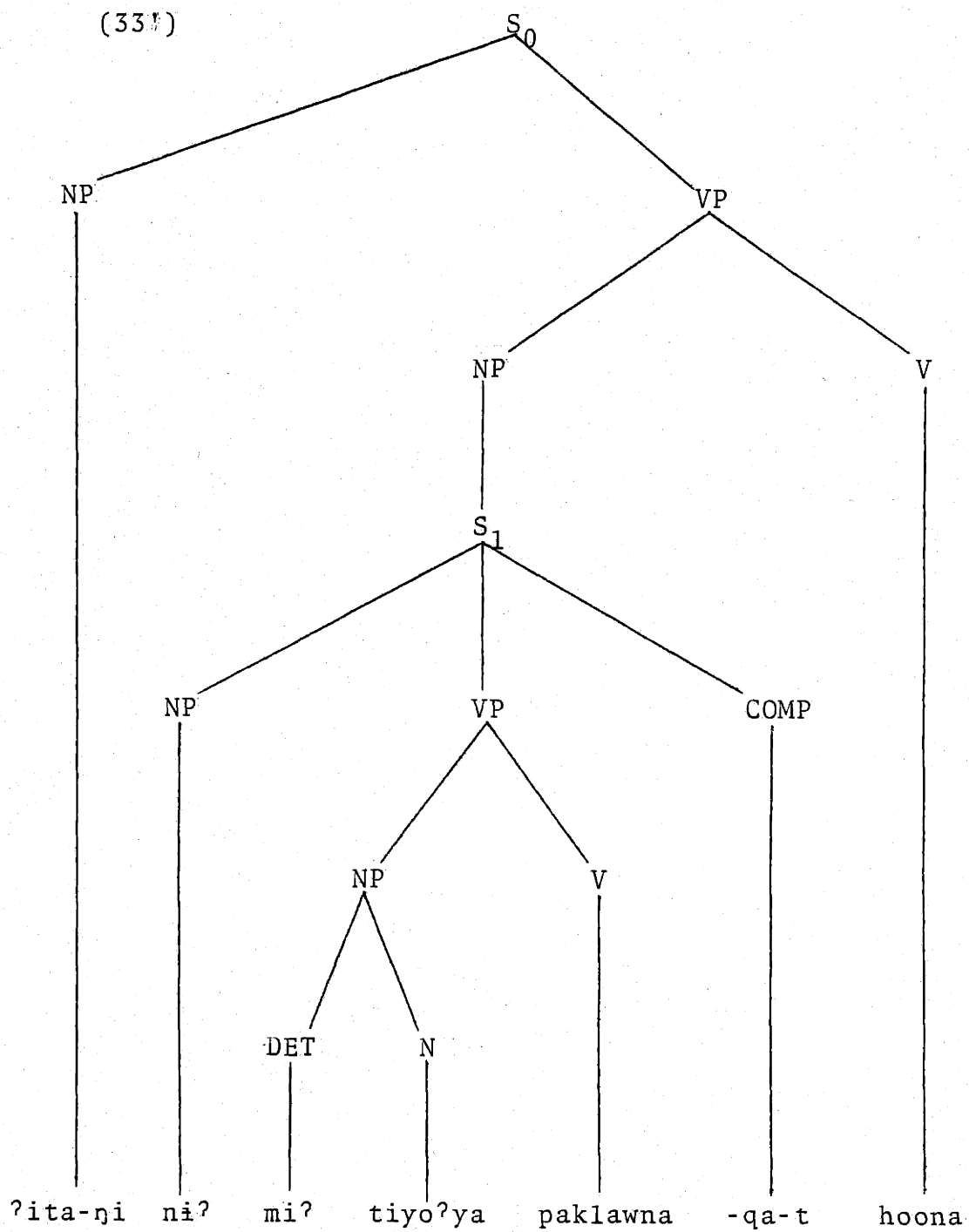

On the inner cycle, /mi? tiyo?ya/ gets case marked by NP-Case Assignment, giving,

(33'')

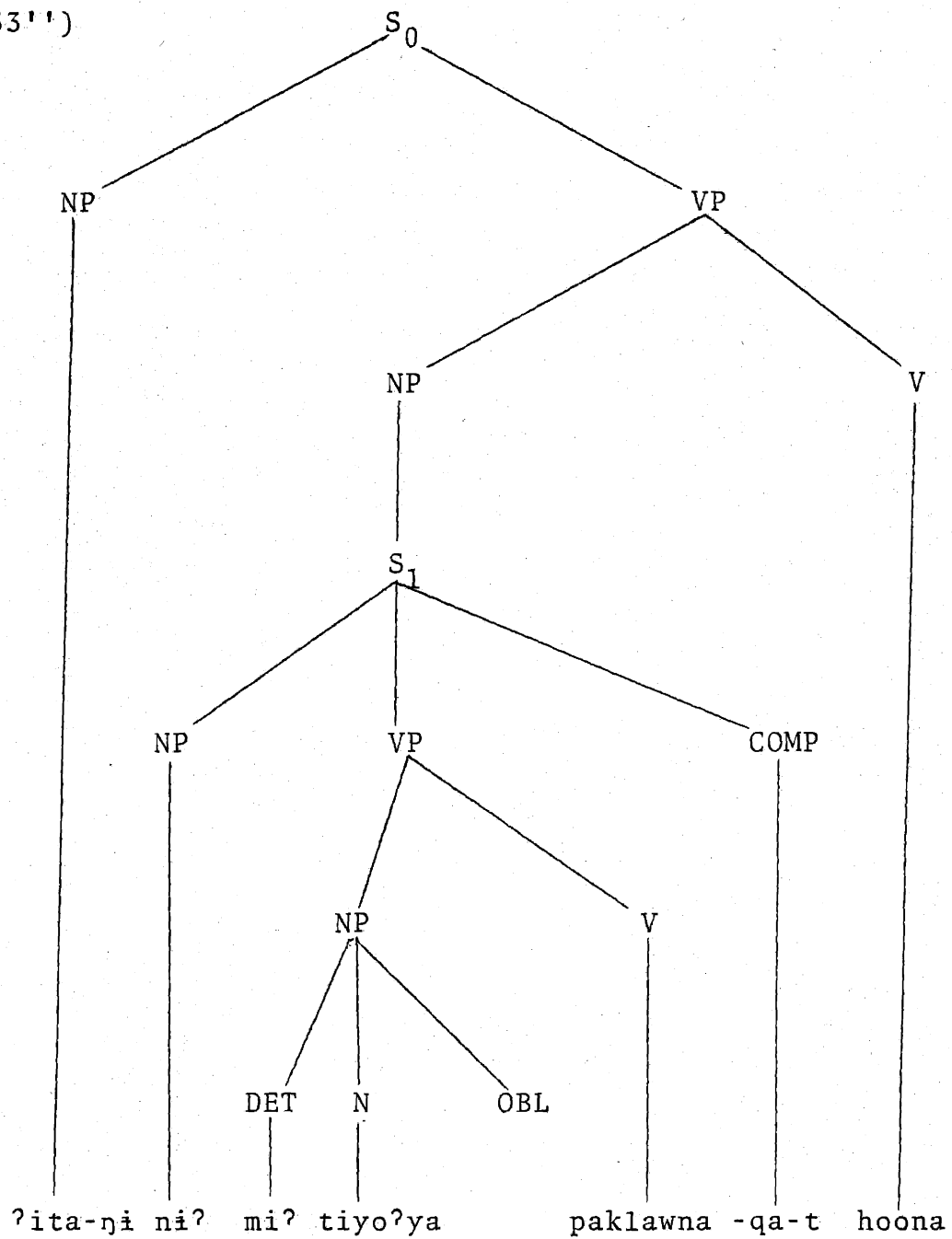

On the next cycle  $S_0$ , it is raised to head position giving,

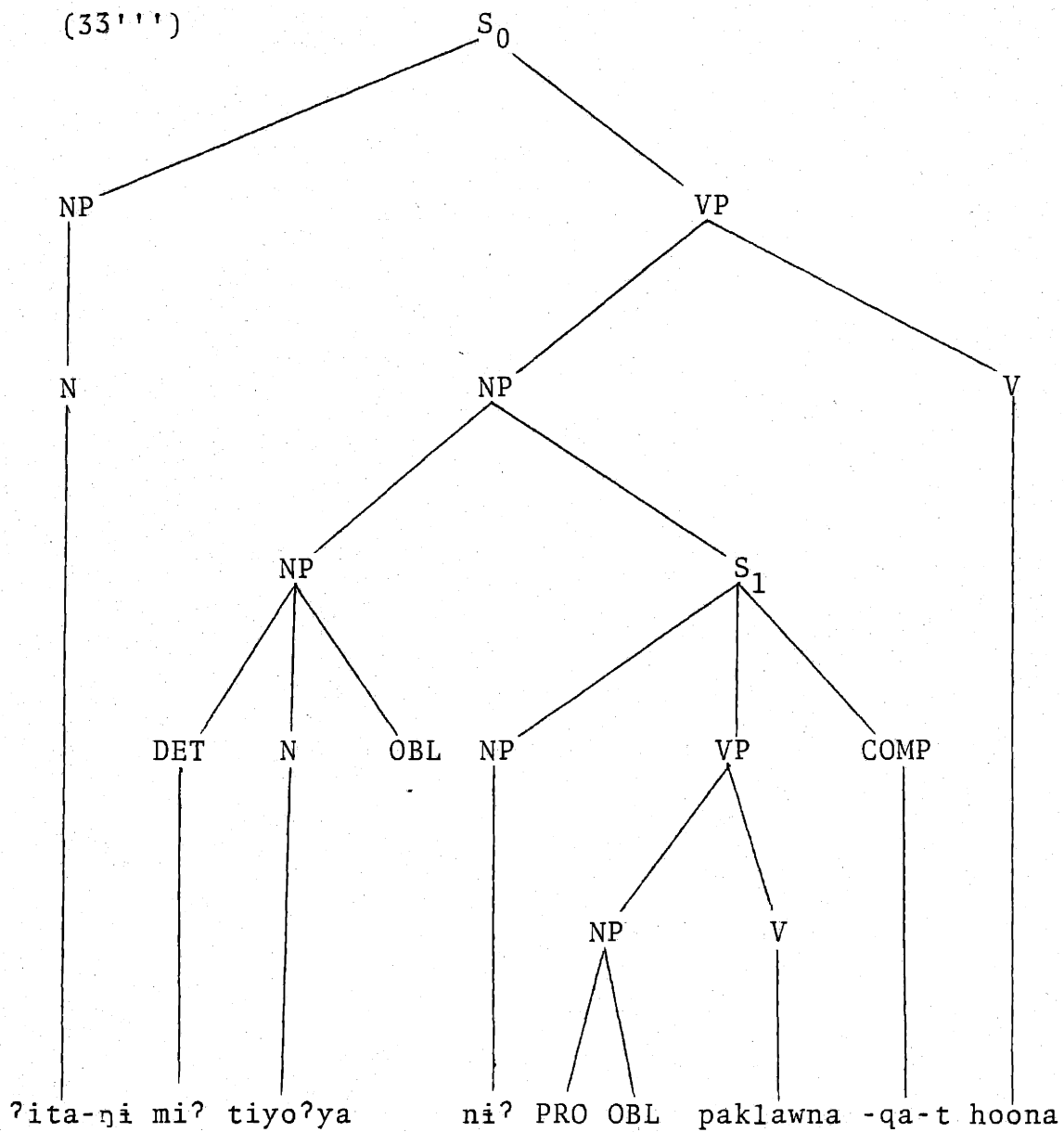

In addition, NP-Case Assignment has a chance to apply; it

applies, giving,

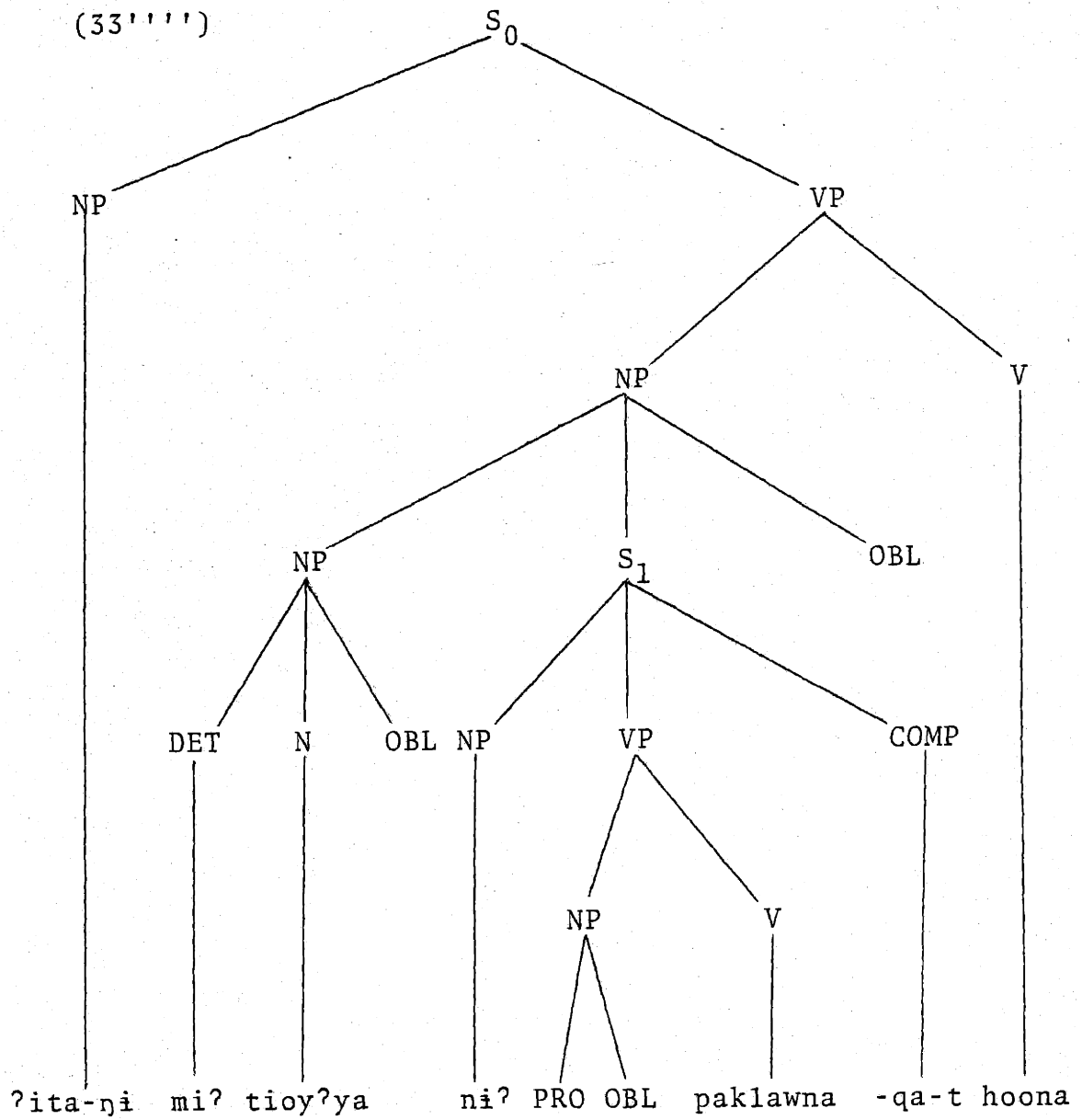

Case Concord applies next, supplying S<sub>1</sub> and the head noun



phrase with the OBL ending, giving,

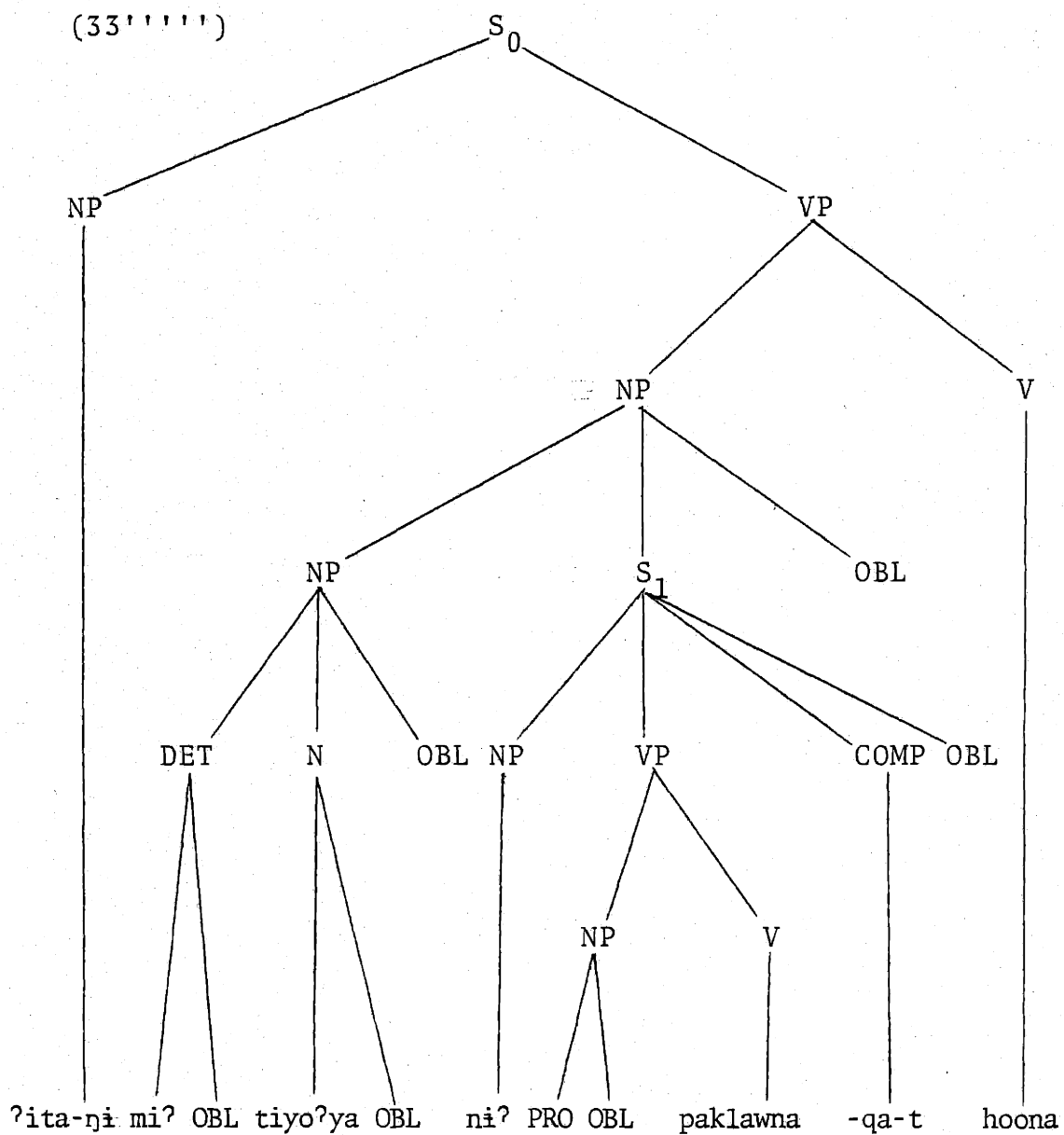

These steps ultimately derive a sentence,

(33) ?ita-ŋi mi-t tiyo?ya-t [ni? (pi-t) paklawna-qa-t  
 hoona

Finally, consider one other relative clause in object position that is,

(34) ni? mi-t tiyo?ya-t [(pam) nimaa-qa-t  
 (I that-OBL boy-OBL (he) went:home-REL-OBL  
 tiwa  
 see)  
 'I saw the boy that went home.'

which would derive from underlyingly,

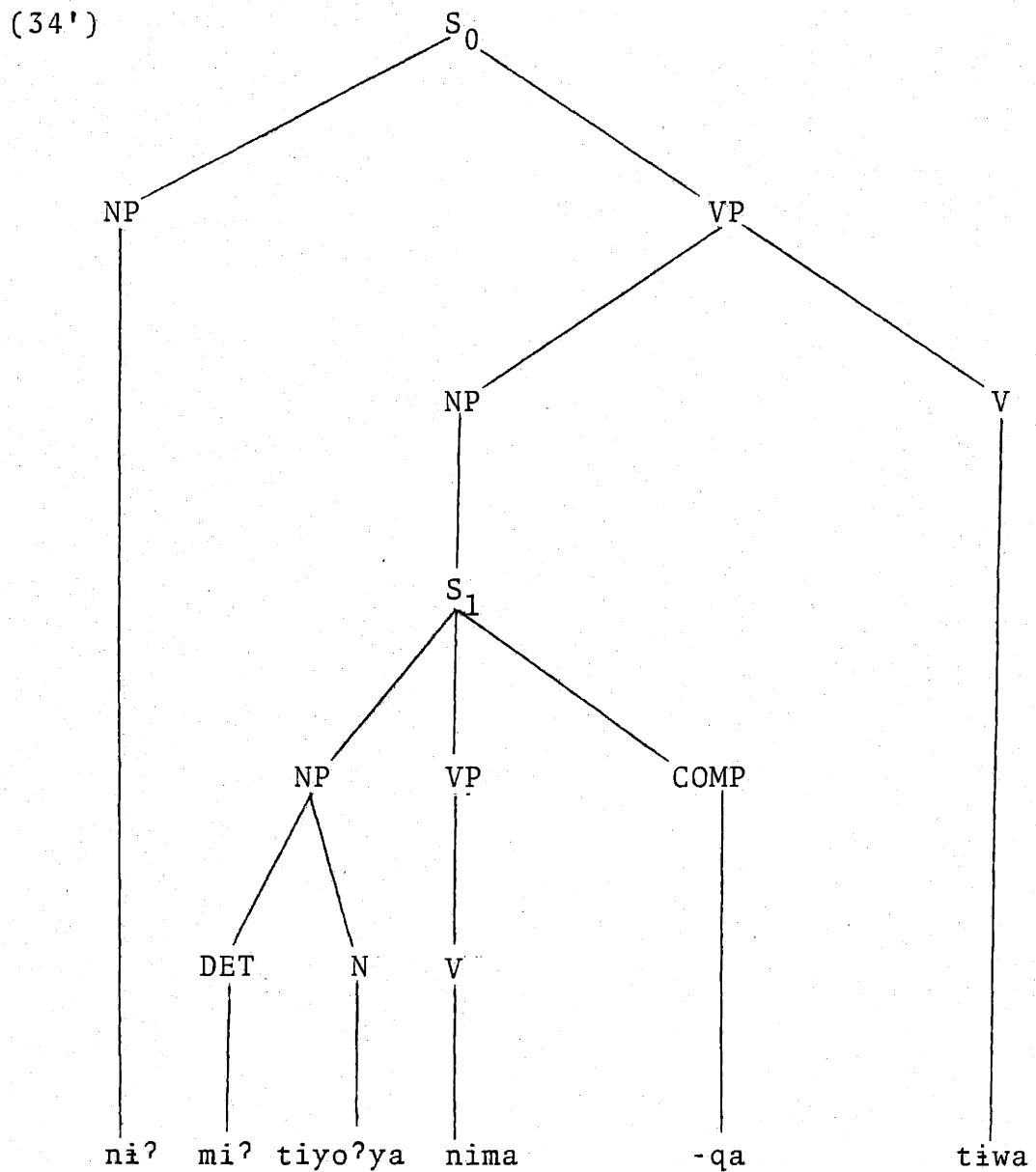

On the  $S_1$  cycle /mi? tiyo?ya/ does not get case marked, because it is a subject, i.e. it is dominated by S. On the  $S_0$  cycle, it is raised to head position, giving,

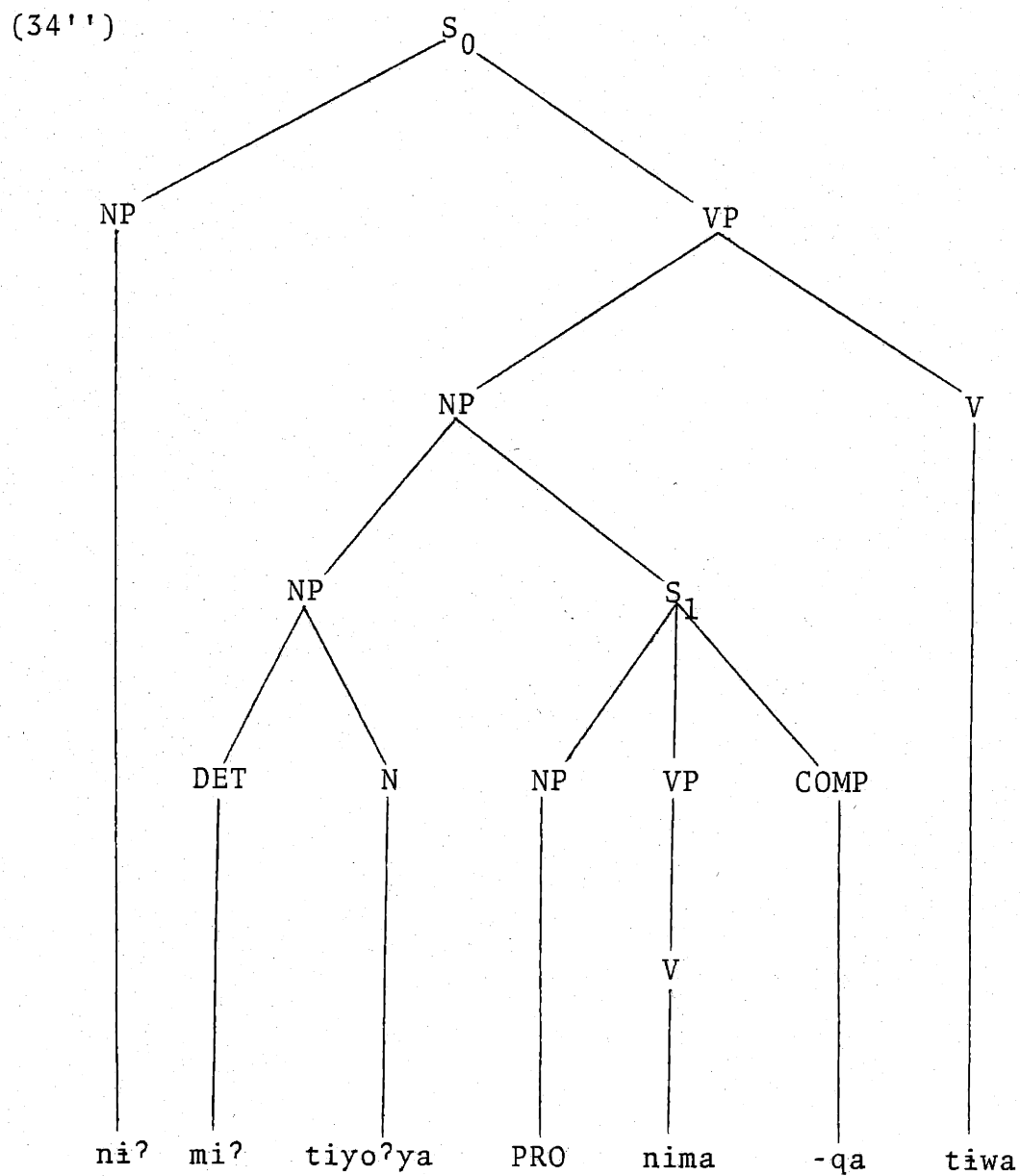

Also, on the  $S_0$  cycle, as the object NP of the main verb /tiwa/ the complex NP is now case marked by NP case assignment:

(34''')

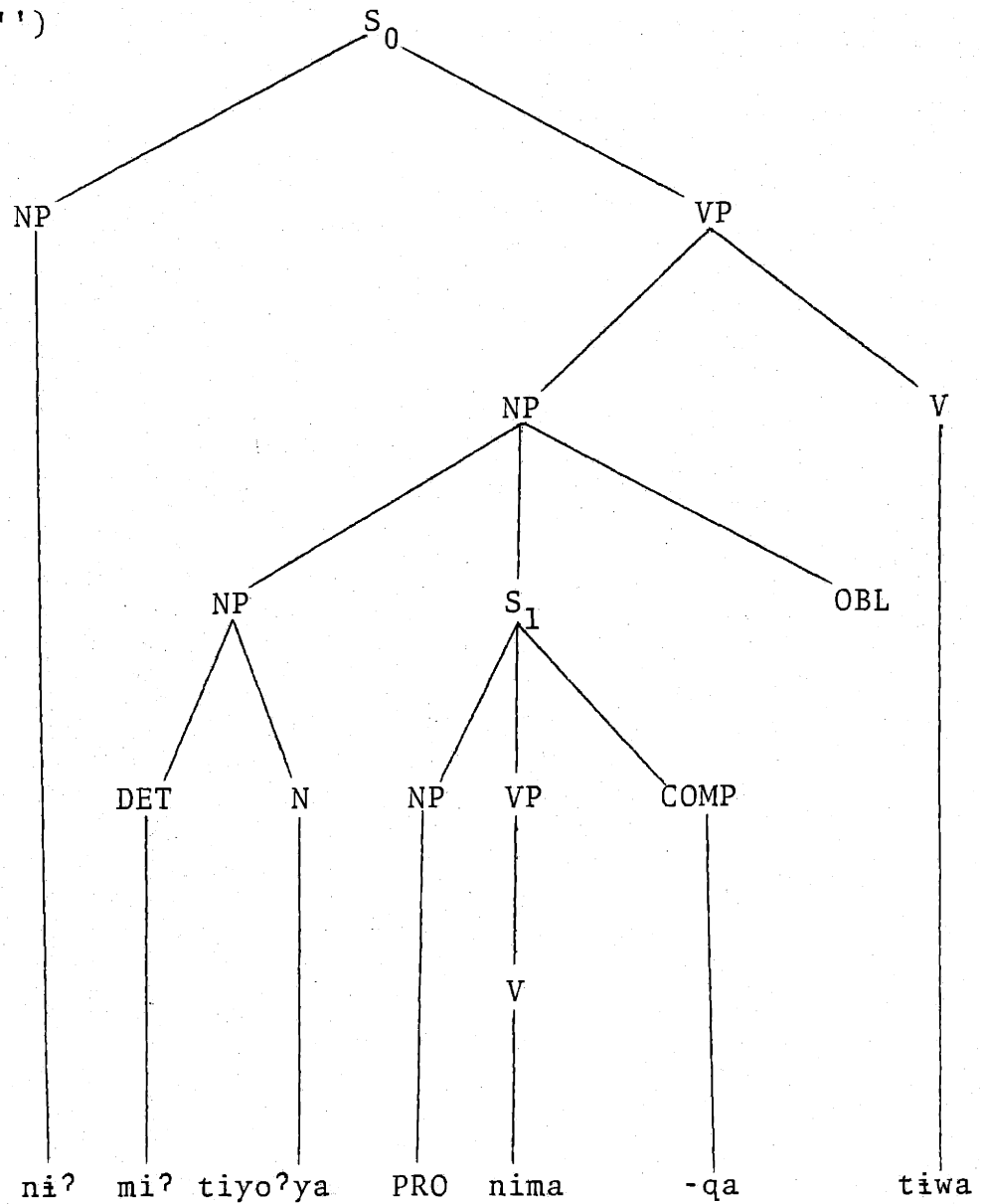

Next, Case Concord will "spread" the OBL ending onto both the head NP as well as the relative clause. This results in,

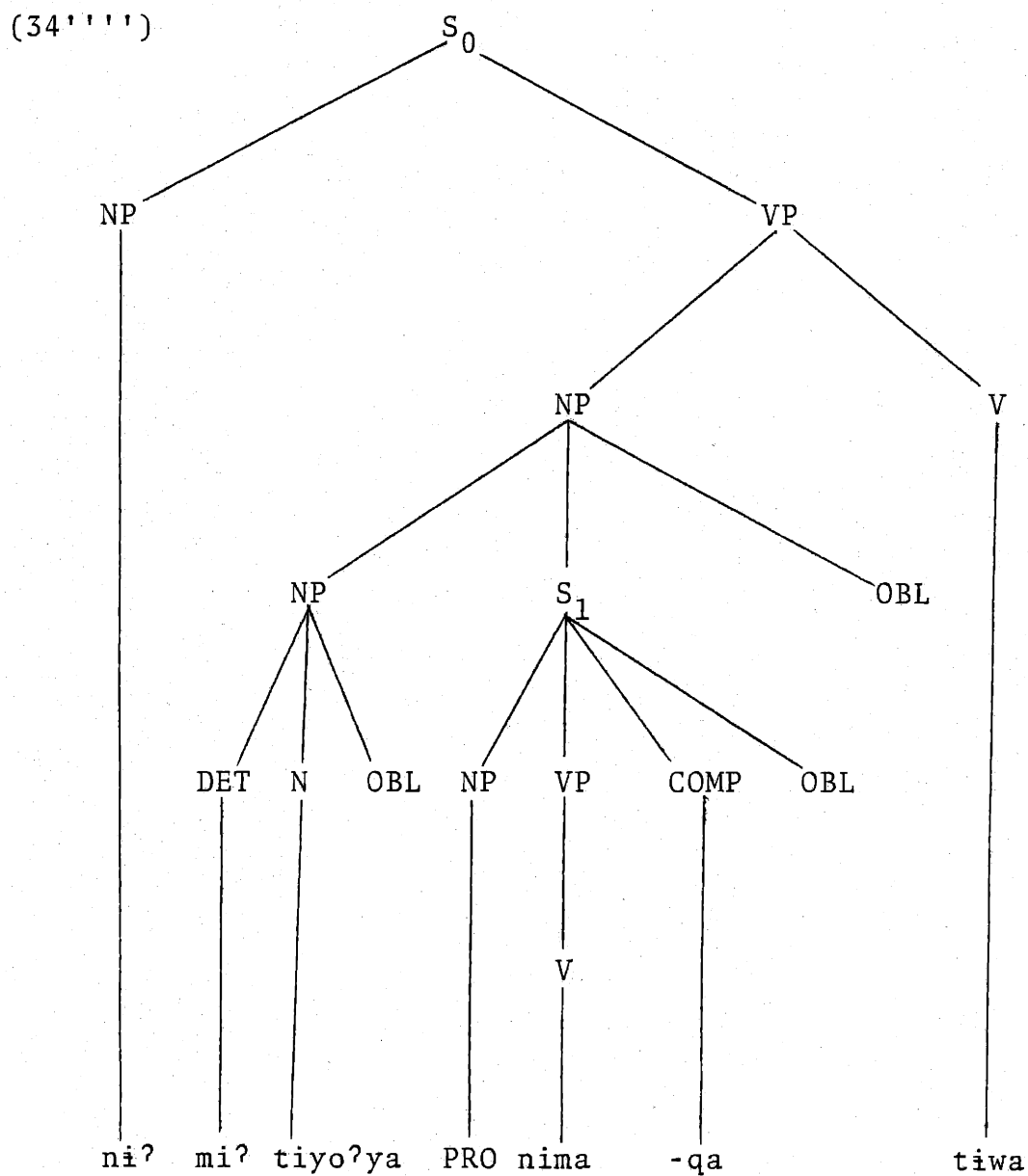

Notice that the head NP is subject to reapplication of the Case Concord rule, since it meets its structural description. Case Concord applies, giving,

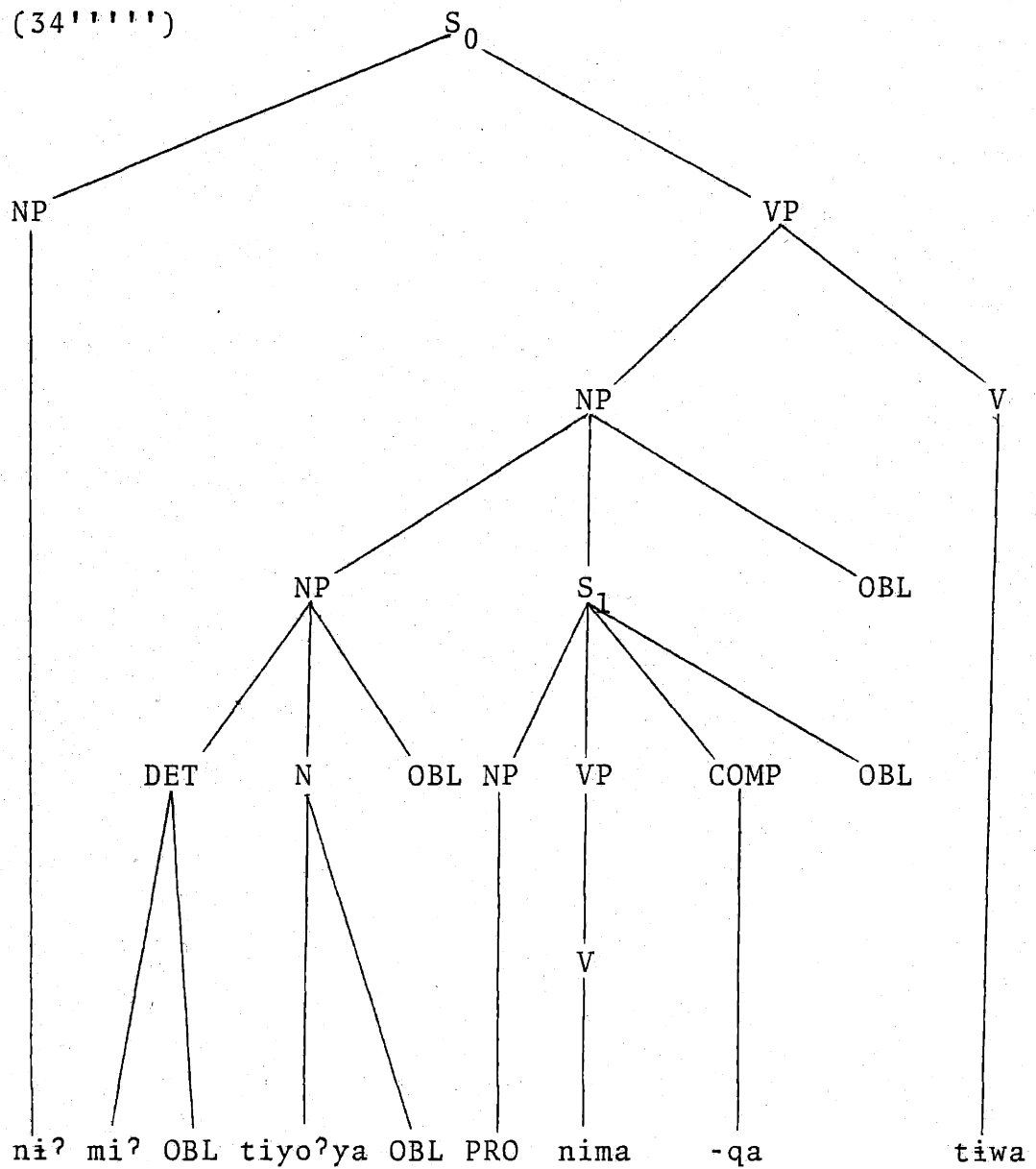

This gives rise to the sentence,

(34) ni? mi-t tiyo?ya-t [(pam) nimaa-qa-t] tiwa.

### 3.3.2. Condition on the Raising Rule

The raising hypothesis must address itself to certain problems, one of which we briefly mention at this point. The raising rule is evidently not an option in Hopi. Rather, there are at least three situations which must be recognized. In the first situation, raising is simply an option; this concerns structures of the kind discussed initially, that is,

(20) mit tiyo?yat ni? pit tiwi?ytaqat po?ko?at mooki

(21) ni? mit tiyo?yat tiwi?ytaqat po?ko?at mooki

Either way is acceptable.

In other structures, raising is highly preferred, for example,

(35) \*?ni? [?i-na mi-t tiyo?ya-t wiva?ta-qa-t] hoona  
 (I my-father hit-REL-OBL sent:home)



(36) ni? mi-t tiyo?ya-t [ʔi-na (pi-t) wiva?ta-qa-t]  
 hoona

'I sent home the boy that my father hit.'

Sentence (36) is preferred over (35). In still other cases, e.g. the type represented by (37),

(37) \*ni? [mi? tiyo?ya pakmimiya-qa-t] hoona  
 (I the boy cry-REL-OBL sent:home)  
 'I sent home the boy that is crying.'

the raising is absolutely obligatory. This may be due to the action of a surface filter to the effect that a noun phrase which appears to be in object position must be in the oblique case. However, we have not investigated thoroughly the conditions under which these apparent 'degrees' of acceptability arise.

3.4.0. Some New Facts

In Hopi, sentences can be in "topicalized" form, for example,

(38) mi? maana, pam pakmimiya

(that girl she cry)

'That girl, she is crying.'

(39) mi? maana, ni? pi-t tiwa

(that girl I her-OBL see)

'That girl, I saw her.'

This kind of structure is widely used in Hopi. Let us assume temporarily that the topic-comment structure is of the following form,

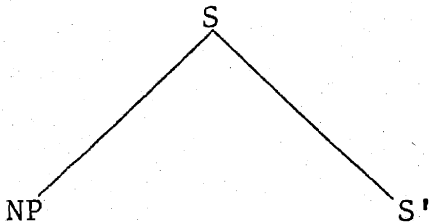

with a pronoun in S' referring pleonastically to the noun phrase topic.

Noun phrases with relative clauses are also topicalized, for example,

- (40) mi? tiyo?ya ni? pi-t tiwaa-qa-t, pam pay  
 (that boy I him-OBL see-REL-OBL he already  
 nima  
 went:home)  
 'That boy, whom I saw, he already went home.'

In (40), an entire complex noun phrase is serving as topic. Notice, however, that the topic noun phrase is a counter-example to our assumptions about the well-formedness of complex noun phrases with respect to case marking. Specifically, the problem is (1) how does the oblique ending /-t/ get on the relative clause--e.g. /ni? pi-t tiwaaqa-t/, and (2) why is the head noun phrase /mi? tiyo?ya/ unmarked?

Furthermore, notice that the raising analysis would derive, not (40), but (41),

- (41) mi-t tiyo?ya-t [ni? pi-t tiwaa-qa], pam pay nima

To see how, consider a possible derivation for (41), which presumably is underlyingly,

(41')

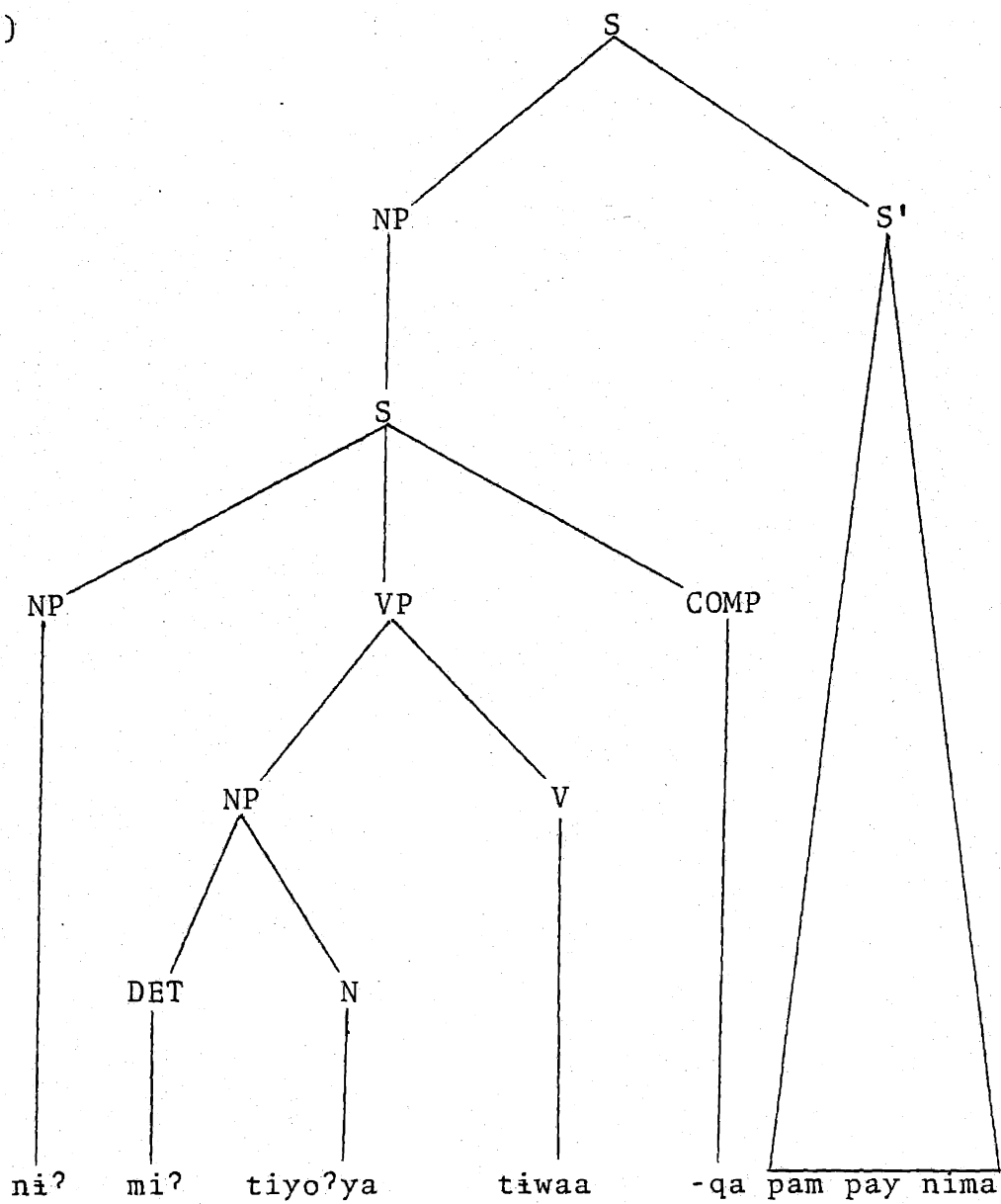

On the inner cycle, Case Assignment attaches an OBL ending to the object noun phrase giving,

(41'')

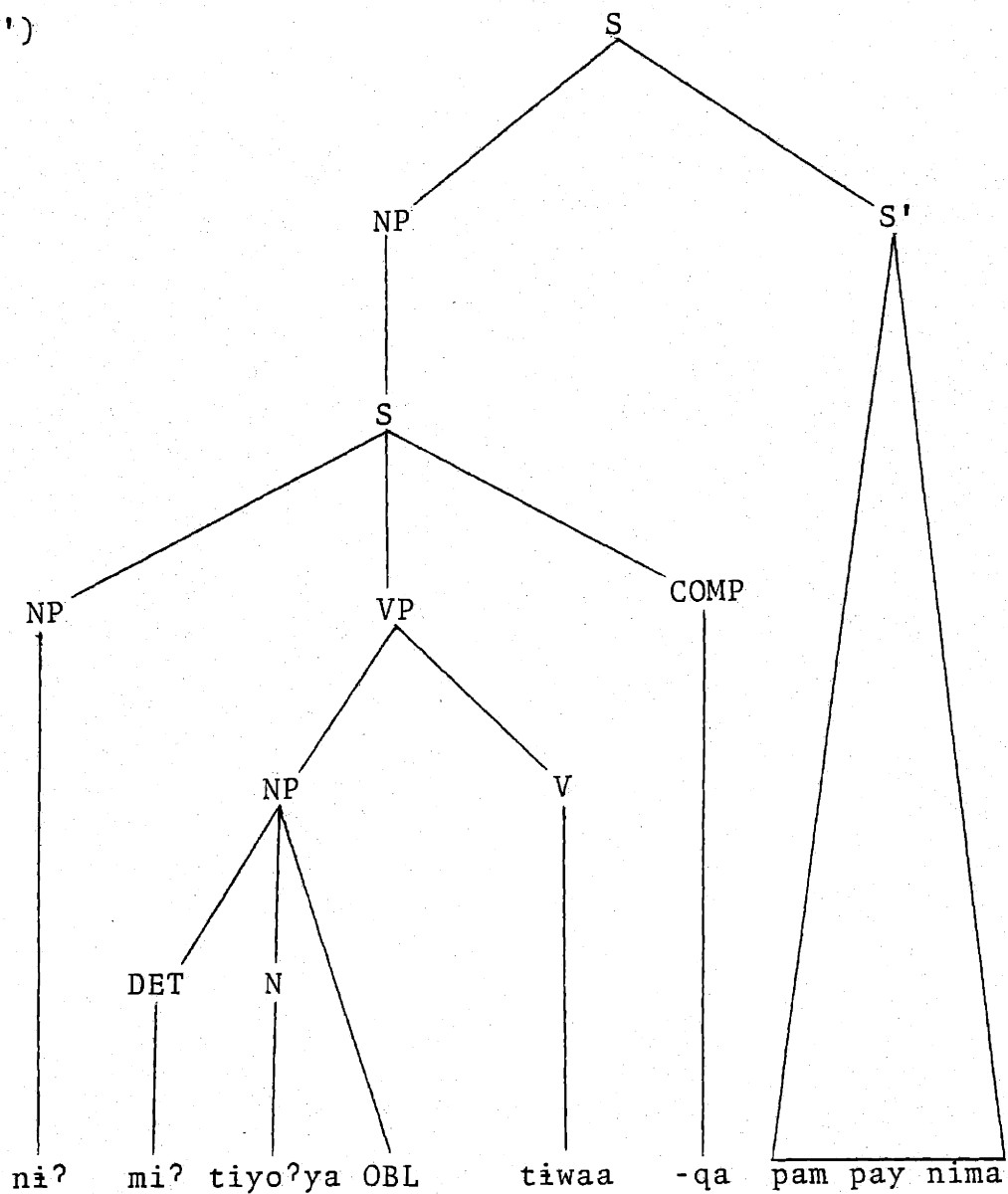

On the next cycle, raising and Case Concord apply, giving,

(41''')

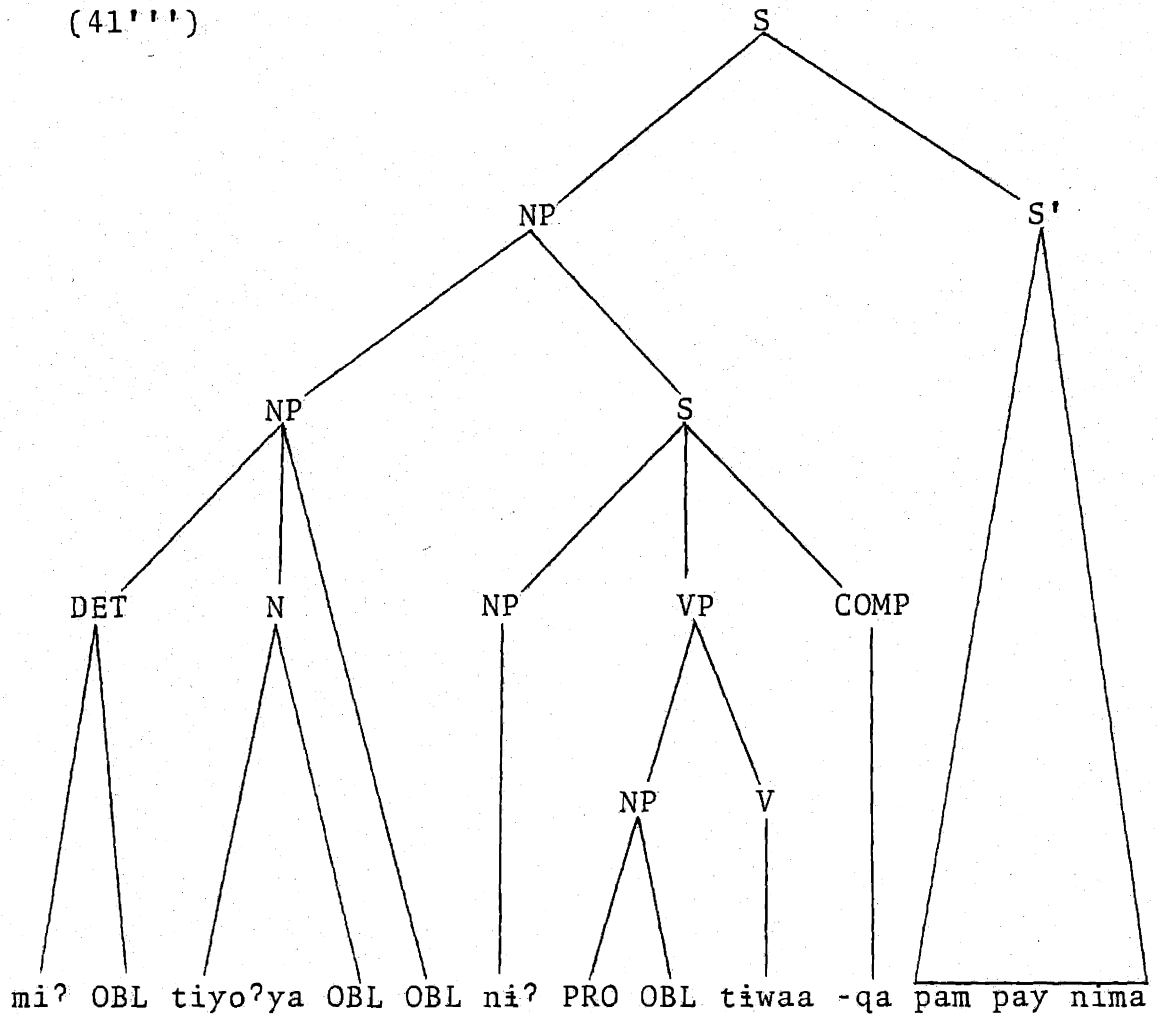

This structure ultimately derives the ungrammatical sentence,

(41) \*mi-t tiyo?ya-t [ni? (pi-t) tiwaa-qa], pam pay nima

and not,

(40) mi? tiyo?ya [ni? (pi-t) tiwaa-qa-t], pam pay nima.

In answer to the problems posed by (40) above, we suggest the following initial possibility. First, let us retreat momentarily from the raising hypothesis and assume that (40) starts out in the base as in (40'), that is, with an overt head noun phrase:

(41')

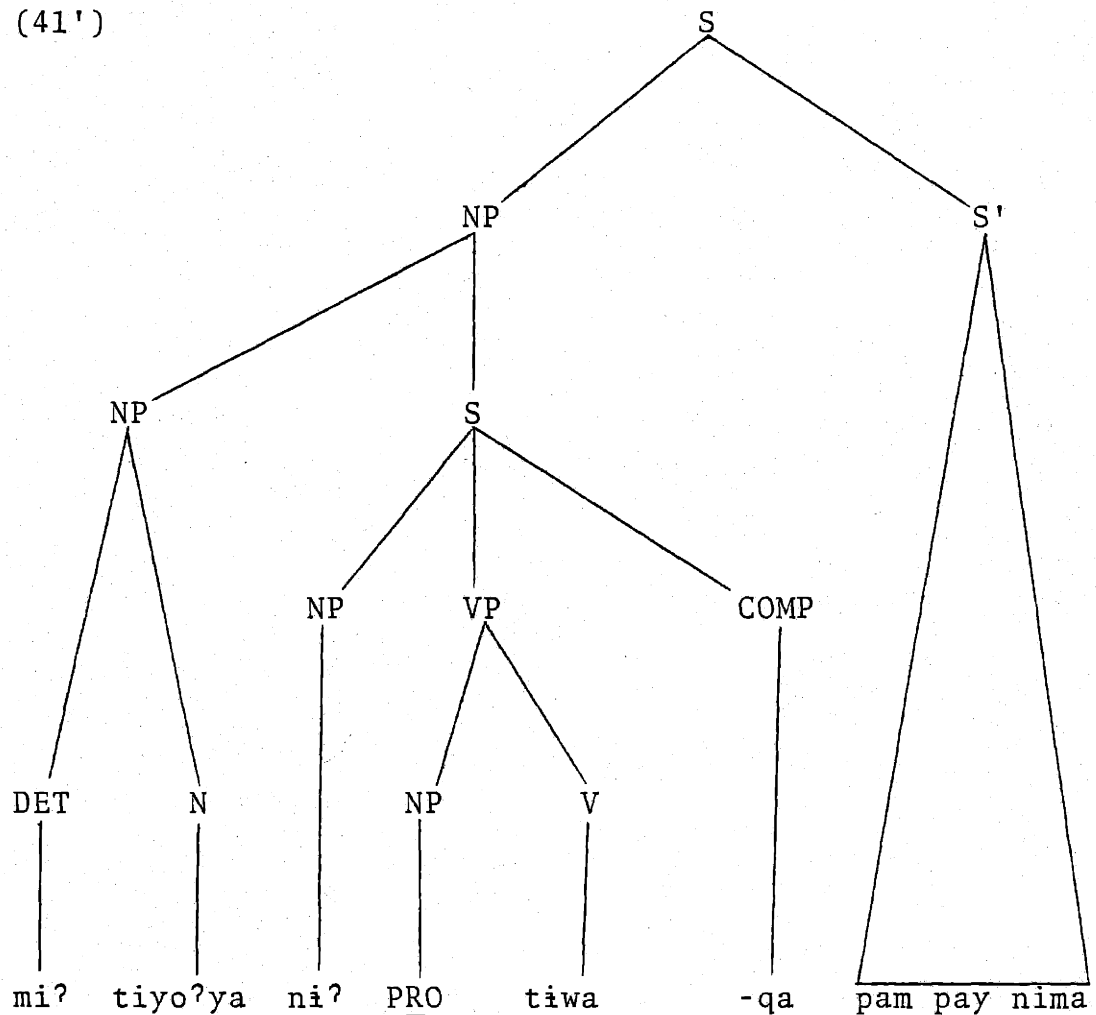

Second, let us assume that since the entire complex noun phrase is in topic position it is not marked with the oblique case. This has the effect of leaving the head noun phrase unmarked. We are now left with the problem of explaining the appearance of the oblique ending on the relative clause. Notice that the relative clause must be marked for oblique case as illustrated by the following sentence,



(42) \*mi? tiyo?ya, [ni? (pi-t) tiwaa-qa,] pam pay nima

Suppose we said that the /-t/ ending on the relative clause in (40) is due to the complex noun phrase being in topic position. However, this cannot be entirely right, for consider the following sentence,

(43) mi? tiyo?ya, pam ni-y tiwaa-qa, pam pay  
 (that boy he I-OBL see-REL he already  
 nima  
 went:home)

'The boy that saw me, he already went home.'

In this sentence, both the head and the complex noun phrase are unmarked. The gross syntactic structure is the same as that proposed for (40). So why the difference?

Comparing (40) and (43), that is,

(40) mi? tiyo?ya, ni? pi-t tiwaa-qa-t, pam pay nima

(43) mi? tiyo?ya, pam ni-y tiwaa-qa, pam pay nima

notice that the relative noun phrase functions as object in the relative clause in (40), while in (43), it functions as subject. This suggests that the oblique case-ending on the relative clause in cases like (40) and (43) depends on the grammatical relation born by the relative noun phrase. Prior to this, we assumed that the grammatical relation of the whole noun phrase was what determined case marking. Now it seems that the grammatical relation of the relative noun phrase plays a role in determining case assignment to /-qa/.

Now consider the following sentence:

- (44) mi? tiyo?ya, ni? pi-t tiwi?yta-qa-y ni? pi-t  
 (that boy I him-OBL know-REL-OBL I him-OBL  
 ?a-mim timala?yta  
 him-with work)  
 'The boy that I know, I work with him.'

In (44), the relative clause is again marked for oblique case, while the head is unmarked. But, more importantly, notice that the oblique ending on the relative clause is now [-y]. In other words, (44) and (40) are exactly alike structurally, with one crucial difference--and it has to do with coreference or non-coreference between the subjects of the main and

embedded clauses. In (40), the subject of the main clause and the subject of the embedded clause are disjoint in reference; in (44), they are coreferential.

This, as the reader will recall, is the obviation principle discussed at various points in chapter 2. In the section immediately following we deal with the obviation principle in more detail. We will attempt to formalize the principle according to which case is assigned to the relativizing complementizer /-qa/.

#### 3.4.1. Qa-Case Assignment

The principle of /-qa/-Case Assignment for singulars can be expressed as follows:

- (45)            /-qa/-Case Assignment
- (i)            unmarked (i.e. /-qa/): shared subjects, and relative noun phrase is subject in its own clause;
  - (ii)           'proximate' (/ -qa-y/): shared subjects, and relative noun phrase is non-subject in its own clause;
  - (iii)           'obviative' (/ -qa-t/): otherwise.

The following three sentences illustrate the three cases subsumed under (45i-iii):

- (45) (i) mi? tiyo?ya (pam) ?acata-qa pakmimiya  
 (that boy (he) lie-qa cry)  
 'The boy who lied is crying.'
- (ii) ni? taavo-t (ni?) (pi-t) niina-qa-y  
 (I rabbit-OBL (I) (it-OBL) kill-qa-PROX  
 sisk<sup>w</sup>a  
 skin)  
 'I skinned the rabbit that I killed.'
- (iii) ni? mi-t tiyo?ya-t (pam) ?acata-qa-t  
 (I that-OBL boy-OBL (he) lie-qa-OBV  
 hoona  
 sent:home)  
 'I sent home the boy that lied.'

/-qa/-Case Assignment for non-singulars is slightly different. It merges cases (ii) and (iii) using the [-y] alternant for both. Case (i) is the same as for singulars, that is, it is unmarked, i.e. /-qa-m/--/-qa/ + non-singular.

The case marking of the /-qa/ is clearly different from case marking of noun phrases. But it is also clear that both

mechanisms are needed to explain the Hopi facts, as we saw in section 3.4.0. earlier. Let us now consider, very briefly, how /-qa/-Case Assignment will explain the Subject Constraint.

### 3.4.2. The Surface Structure Constraint

Let us reconsider the following structural type,

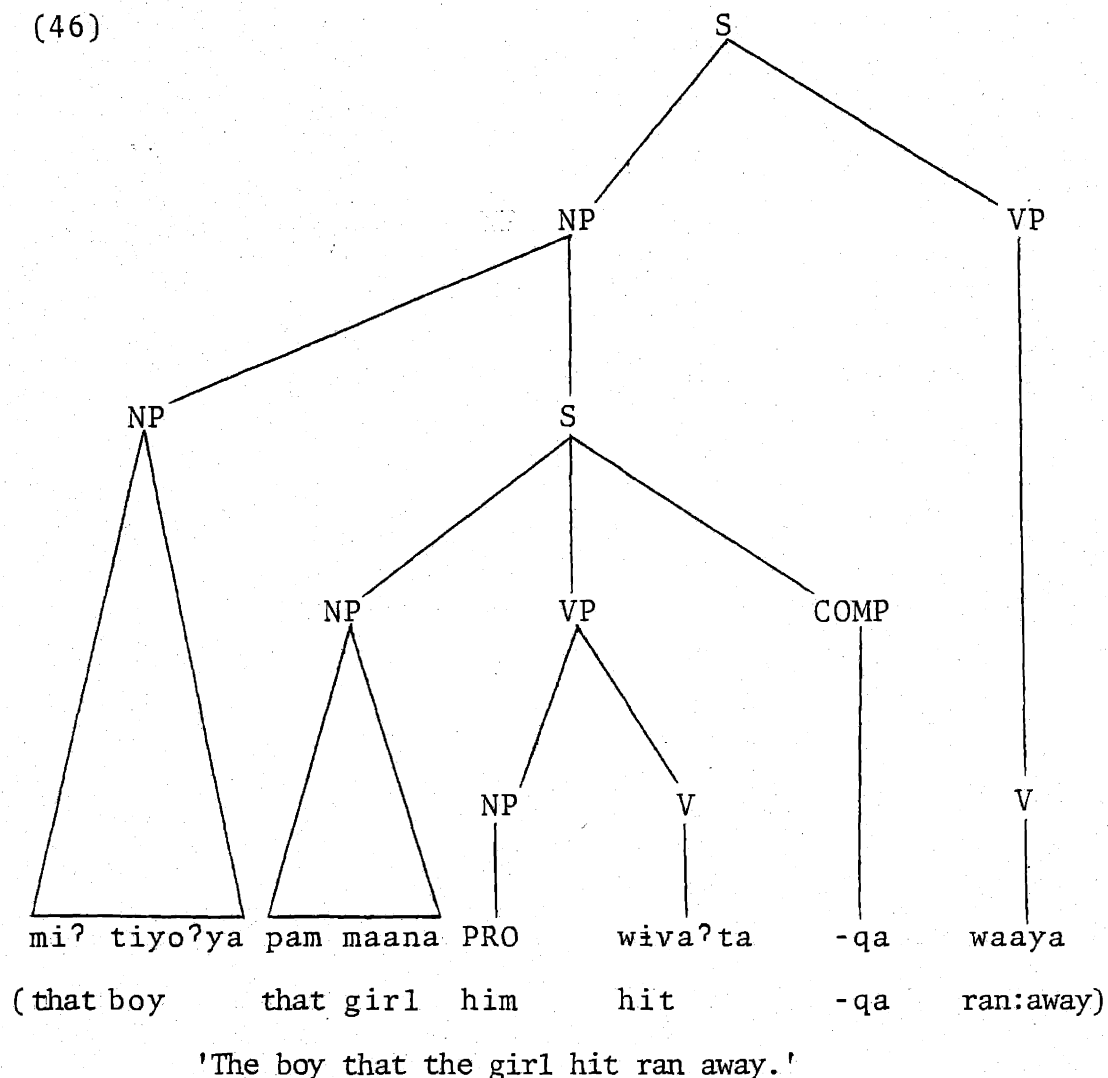

This is the structural type that led to our positing a Subject Constraint. Of the rules and conventions postulated thus far, two are applicable to (46)--namely, NP-Case Assignment and /-qa/-Case Assignment. We are primarily interested here in the latter. By case (iii) of (45), the complementizing relativizer /-qa/ acquires a /-t/ oblique ending, giving,

(47) \*mi? tiyo?ya, pam maana pi-t wiva?ta-qa-t waaya

which, unfortunately, is ill-formed. The ill-formedness of (47) as we discovered, cannot be due to the form of the complex noun phrase itself for that very noun phrase can appear as a well-formed topic, as in,

(48) mi? tiyo?ya, pam maana pi-t wiva?ta-qa-t, pam  
waaya.

Now consider the following fact. There is a well-formed sentence that can be derived from (47) by extraposing the relative clause to a position following the main verb:

(49) mi? tiyo?ya waaya, pam maana pi-t wiva?ta-qa-t.

This extraposition rule is apparently responsible for the following alternations as well:

(50) ?ita-na mi-t tiyo-ya-t ni? pi-t tiwaa-qa-t  
 (our-father that-OBL boy-OBL I see-qa-OBV  
 hoona  
 sent:home)

'Our father sent home the boy that I saw.'

(51) ?ita-an mi-t tiyo?ya-t hoona ni? pi-t tiwaa-qa-t

Presumably, (51) is a variant of (50), derived by an extraposition rule.

Let us assume that we are correct in our guess that (49) is derived by means of an extraposition rule, which we express roughly as follows:

(52) Extraposition

$$\begin{array}{ccc} X & - & S & - & X \\ 1 & & 2 & & 3 \end{array} \quad \Longrightarrow \quad 1 \ 3 \ 2$$

This suggests the possibility that there is another principle operating in Hopi to identify (47) as ill-formed. We would like to propose the following constraint:

(53) Surface Structure Constraint

No NP may be terminated by the oblique ending if it appears in subject position--

i.e. \*  $\begin{array}{ccc} [X & \text{OBL}] & \text{VP} \\ \text{NP} & & \text{NP} \end{array}$

A sentence violating this constraint is identified as ungrammatical. (As can be seen, this constraint makes redundant a part of the NP-Case Assignment rule (26) (or (55) below), suggesting that case assignment should, in fact, be free and that a filtering mechanism should be met to ensure grammatical outputs. This suggestion is similar in spirit to the conception of Hopi grammar at which we ultimately arrive in this work. For the time being, however, no harm is done if we



assume that case is actually assigned by some rule.)

How does the Surface Structure Constraint apply to (47)? Notice that in (47) and (49) the /-qa/ element is marked with the obviative oblique ending /-t/--and this is exactly as it should be by case (iii) of /-qa/-Case Assignment. However, in (47), this results in the circumstances that a complex noun phrase in subject position terminates in an oblique ending. This is in defiance of the prevailing surface fact of Hopi that noun phrases in subject position are unmarked for case. It is in violation of the Surface Structure Constraint.

This constraint will not come into play in cases where a complex noun phrase appears as a topic,

(54) mi-t maana-t ni? pi-t tiwaa-qa-t, pam pay  
 ( girl-OBL I her-OBL see-qa-OBV she  
 nima  
 went:home)

'The girl that I saw, she already went home.'

(In (54), the subject is /pam/ (underlined above).) or, where the relative clause is extraposed as we saw in (49)--since in those cases, the subject will not be terminated by the oblique

ending.

Notice that the Subject Constraint is now eliminated altogether. We still have the ungrammatical sentences (14-16) but they are explained now not in terms of the Subject Constraint but in terms of the interaction between /-qa/-Case Assignment and the Surface Structure Constraint.

The next section will be concerned with the question of the exact nature of the element which we have heretofore referred to by the term "head"--i.e. the noun phrase which appears to the left of the embedded sentence in a relative clause structure. However, before doing this, we will reformulate the rules of NP-Case Assignment and Case Concord.

We will depart from the analysis of oblique case assignment introduced in this chapter--i.e. that according to which the oblique ending is regarded as a separate constituent (OBL) of the noun phrase--and we will use instead a feature notation for the two cases of Hopi, leaving in abeyance the question of how the morphology of cases (i.e. the actual formation of case-marked nominal words) is to be effected. The unmarked case will be designated [-OBL(ique)] and the marked cases will be designated [+OBL(ique)]. These features will be assigned initially to NP-nodes in accordance with the following rule:

(55) NP-Case Assignment (Revised)

(i) NP is [-OBL] in the environments

\_\_\_\_\_ S'

and

\_\_\_\_\_ VP

(ii) NP is [+OBL] otherwise.

Case Concord will be effected by the following rule:

(56) Case Concord (Revised)

A constituent is [+OBL] if immediately dominated by a [+OBL] NP-node.

3.5.0. The Nature of the "Head" in Relative Clauses

There is a parallelism to be observed between the two possibilities for relative clauses, namely,

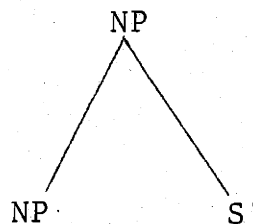

and corresponding possibilities for the other major phrasal categories. Consider, for example, that a S may appear in two general forms,

- (1) the topic comment structure

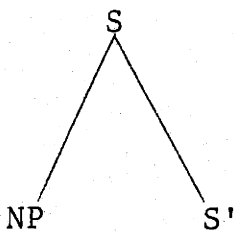

- (2) S alone, without a topic.

Similarly, possessive structures, like the relative clause and the S, have both simple and "pleonastic" forms:

- (1) The simple structure, let us assume, is,

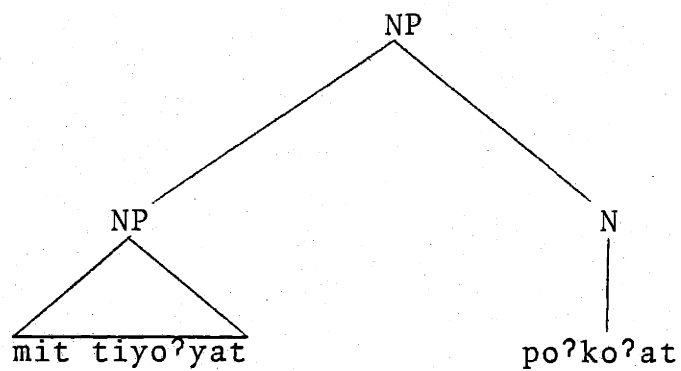

(2) and the pleonastic structure, by contrast, has the form,

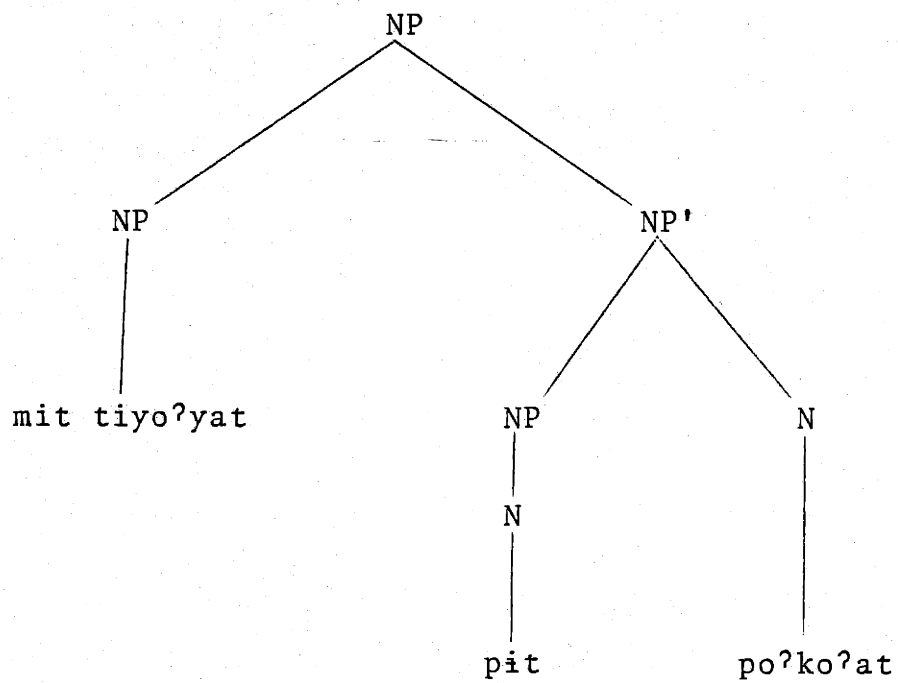

'The boy, his dog.'

The postpositional phrase also exhibits this dual possibility, simple,

(1)

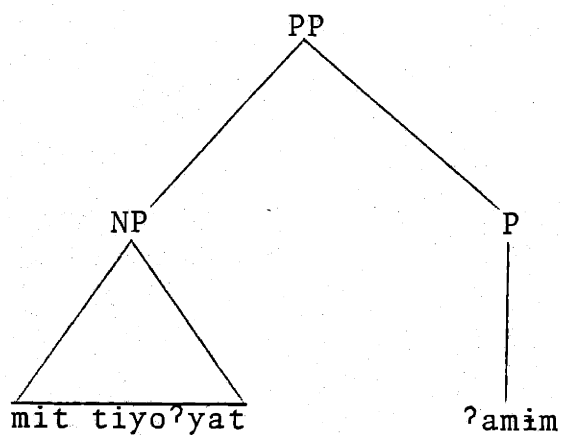

and pleonastic,

(2)

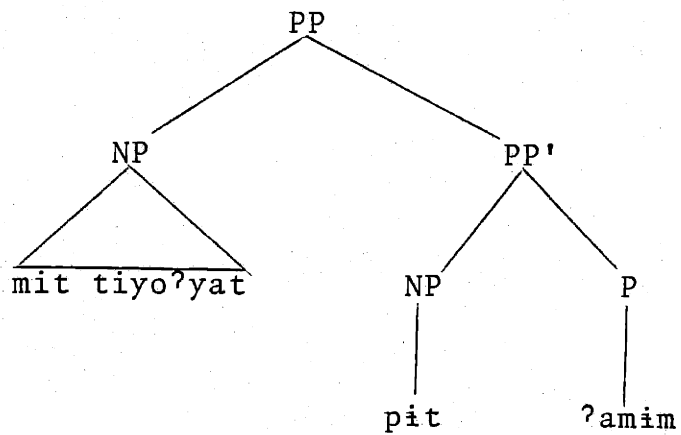

'The boy, with him.'

And finally, the verb phrase also has a "pleonastic" form. Thus, consider first, sentence (57) in which the VP is simple:

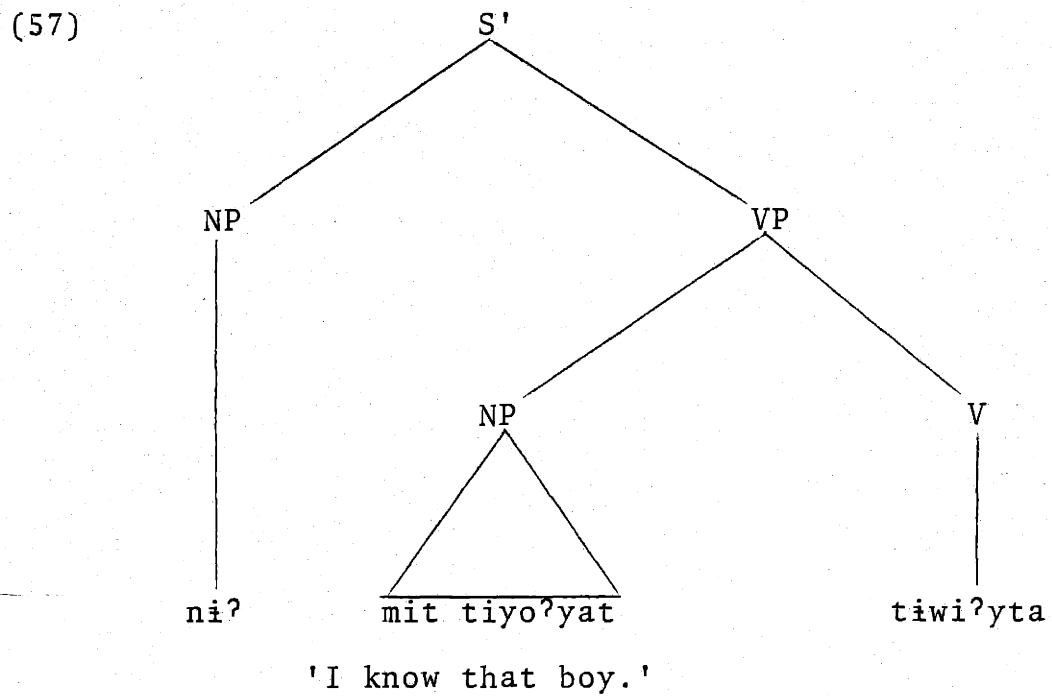

And compare the following, in which the VP is pleonastic:

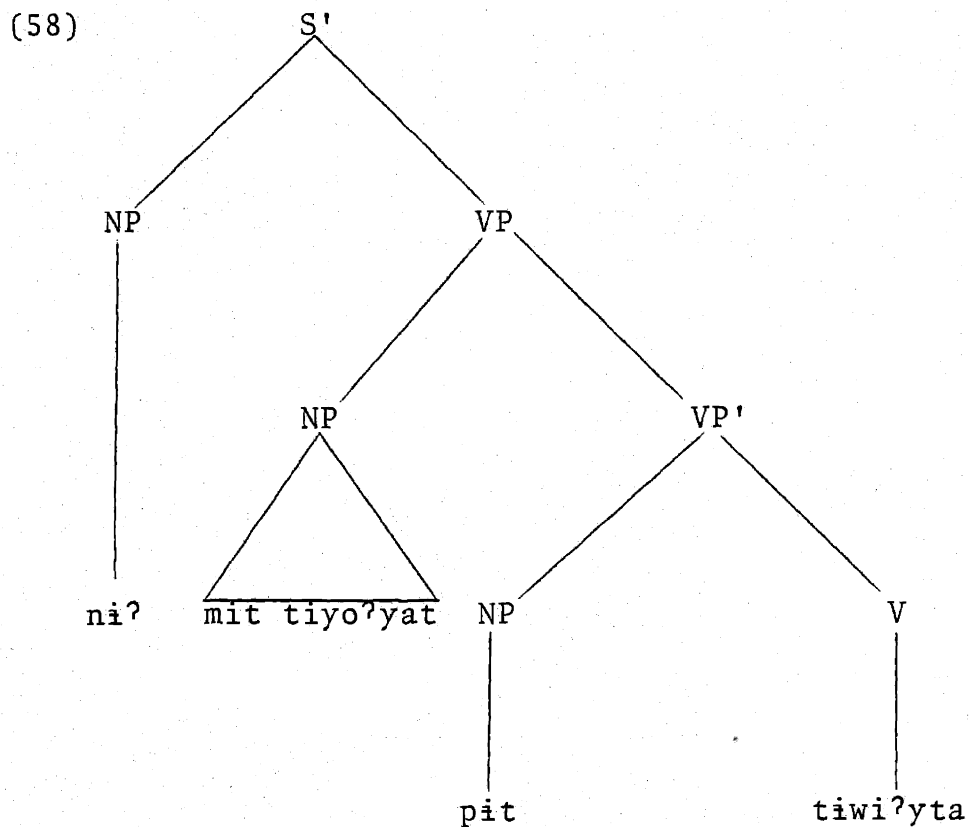

We would like to suggest that the so-called headed relative clause is merely a special case of the pleonastic expansion of the phrasal categories, according to which an optional NP may appear to the right of an obligatory constituent. (The details of the relevant expansion rules will be discussed in the next section.) If this proposal is correct, then it is a mistake to use the term "head" in reference to the NP so labeled heretofore. Henceforth, we will refer to this as the "pseudo-head", the true head must be sought elsewhere (See 3.6. below.).



In fact, Hopi provides evidence in favor of this conception of the so-called headed relative clause. Consider the following fact. The verb /navoti?yta/ cannot take concrete noun phrases as its direct object. That is, one cannot say,

(59) \*ni? mi-t maana-t navoti?yta  
 (I that-OBL girl-OBL know)

to mean,

(60) 'I know that girl.',

instead, one must say,

(61) ni? mi-t maana-t tiwi?yta.

It can, however, take abstract objects as in,

(62) ni? hi?ta        navoti?yta

(I    something know)

'I know something.'

The most productive source of abstract objects is the nominalized S, identical in morphological form to the relative clause. This is exemplified in,

(63) ni? Hotvel-pe        tiikive-ni-qa-t    navoti?yta

(I    Hotevilla-at dance-FUT-qa-OBV know)

'I know that there is going to be a dance at  
Hotevilla.'

But now consider the following two Ss:

(64) ni? mi?    maana noova?yama-ni-qa-t        navoti?yta

(I    that girl    take:food-FUT-qa-OBV know)

(65) ni? mi-t maana-t (pam) noova?yma-ni-qa-t  
 (I that-OBL girl-OBL (she) take:food-FUT-qa-OBV  
 navoti?yta  
 know)

These Ss are cognitively synonymous--i.e. they both mean

(66) 'I know that that girl is going to take food (to  
 the groom's house).'

Let us consider first the apparent deep structure of

(64):

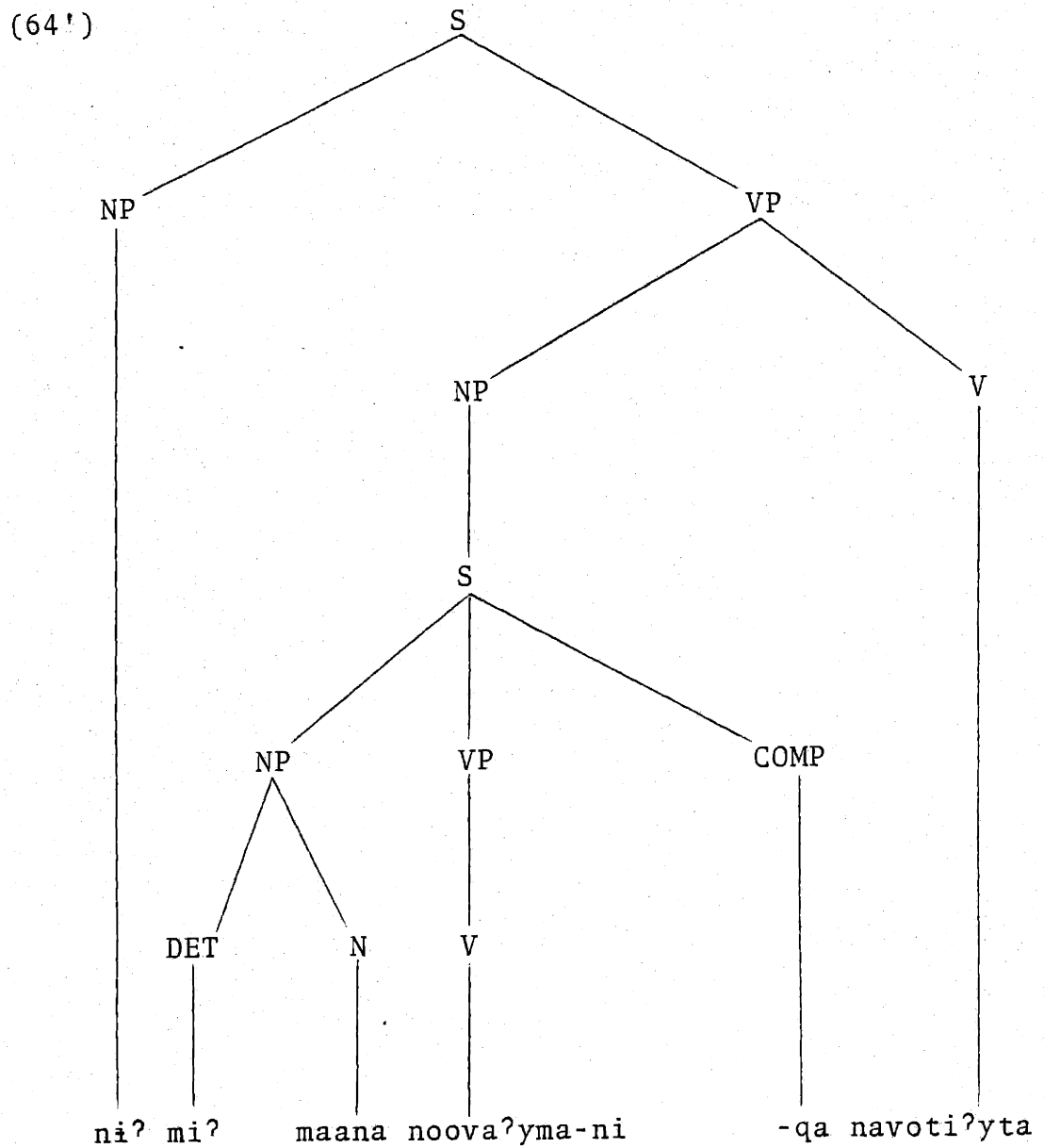

/-qa/-Case Assignment applies to give the surface string (64) above. Notice that NP-Case Assignment assigns [-OBL] to the subject of the subordinate clause. But we must explain how that very NP /mit maanat/ gets an oblique ending in (65).

This case marking would follow automatically if we assumed the following structure for (65):

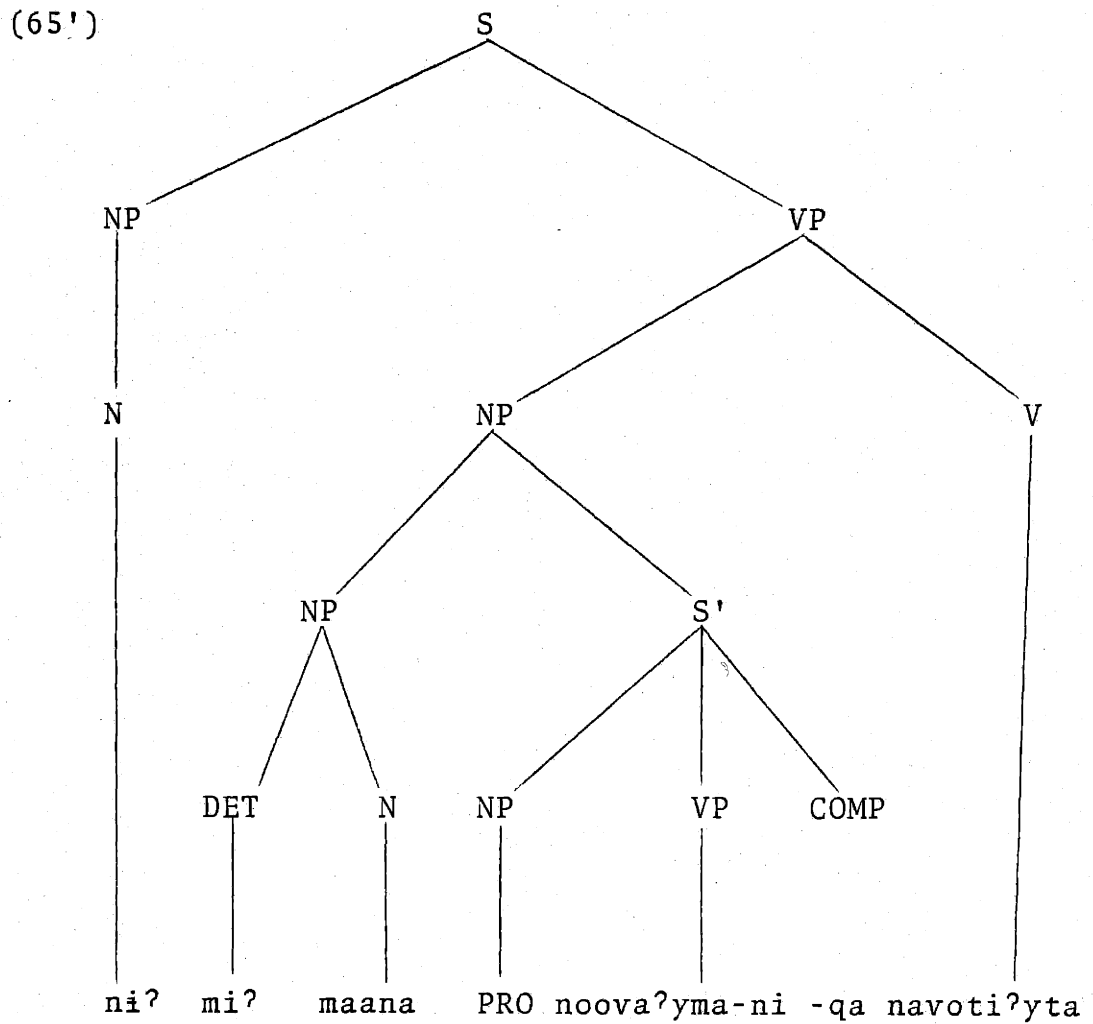

NP-Case Assignment (as revised above) applying to (65') gives,

(65'')

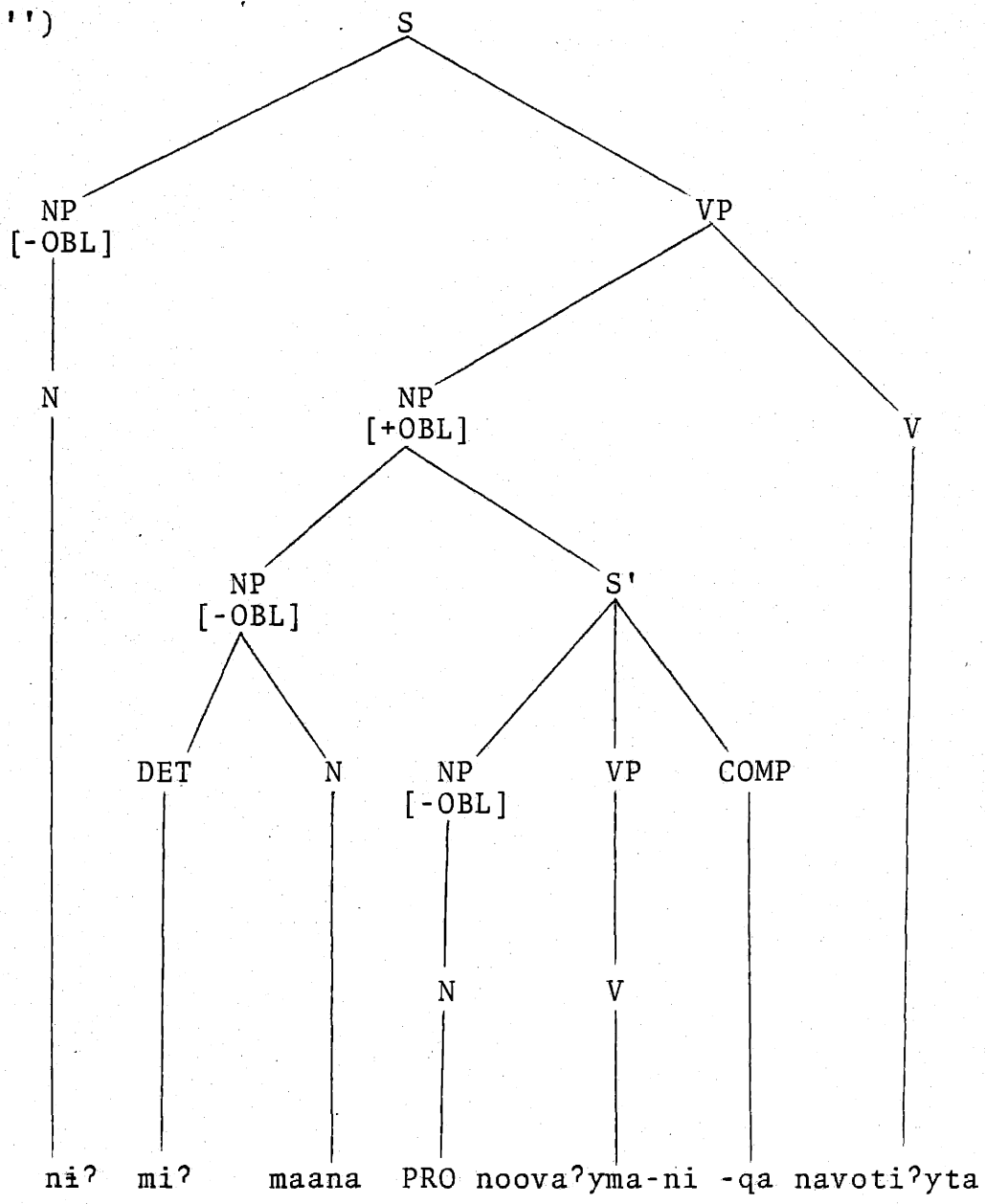

Now notice that Case Concord will apply twice: first, making the "head" NP-node [+OBL], secondly, spreading OBL to the DET and N, giving,

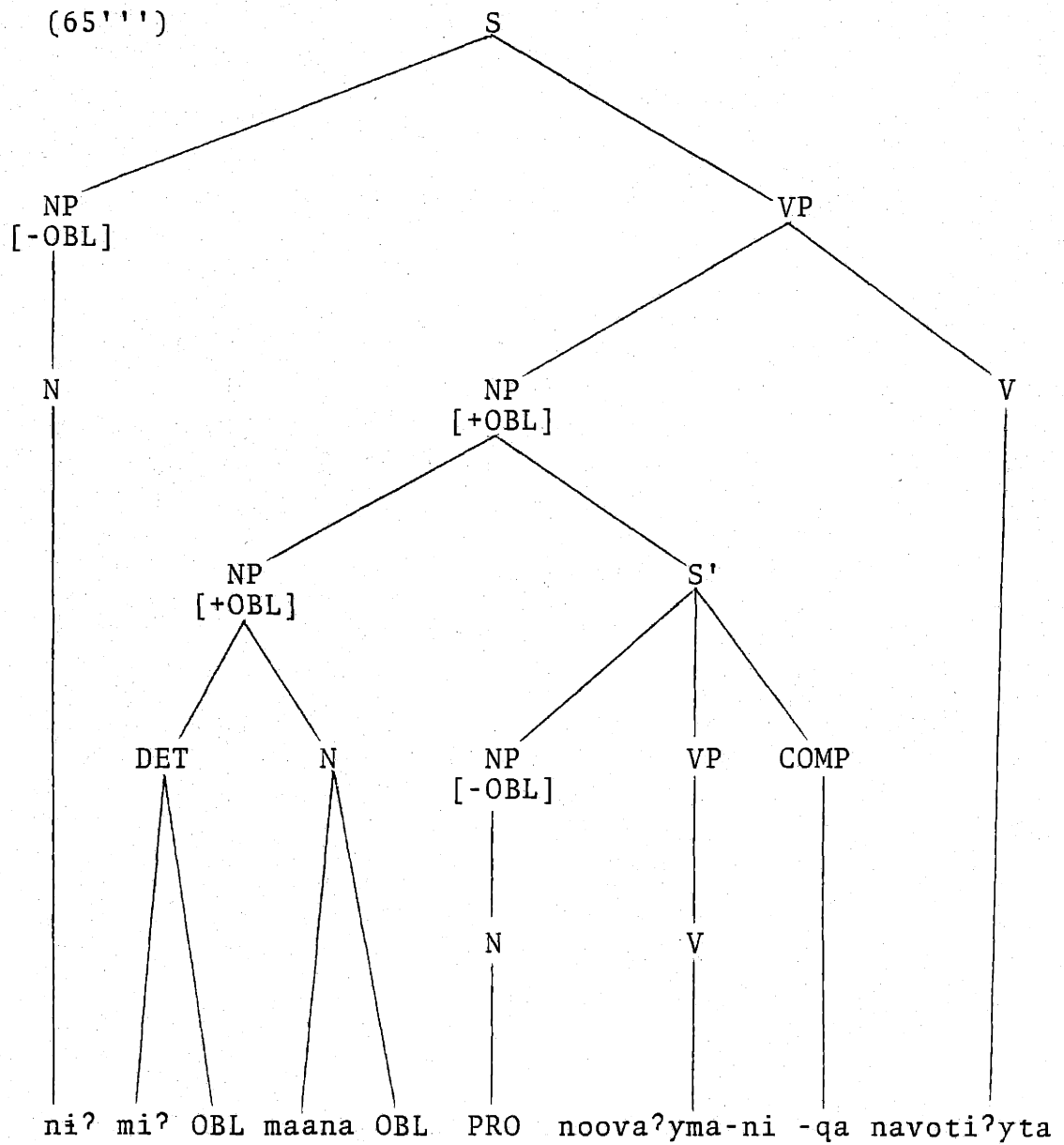

Finally, QA-Case Assignment (principle (3a)) and the morphological rules apply, giving the derived structure:

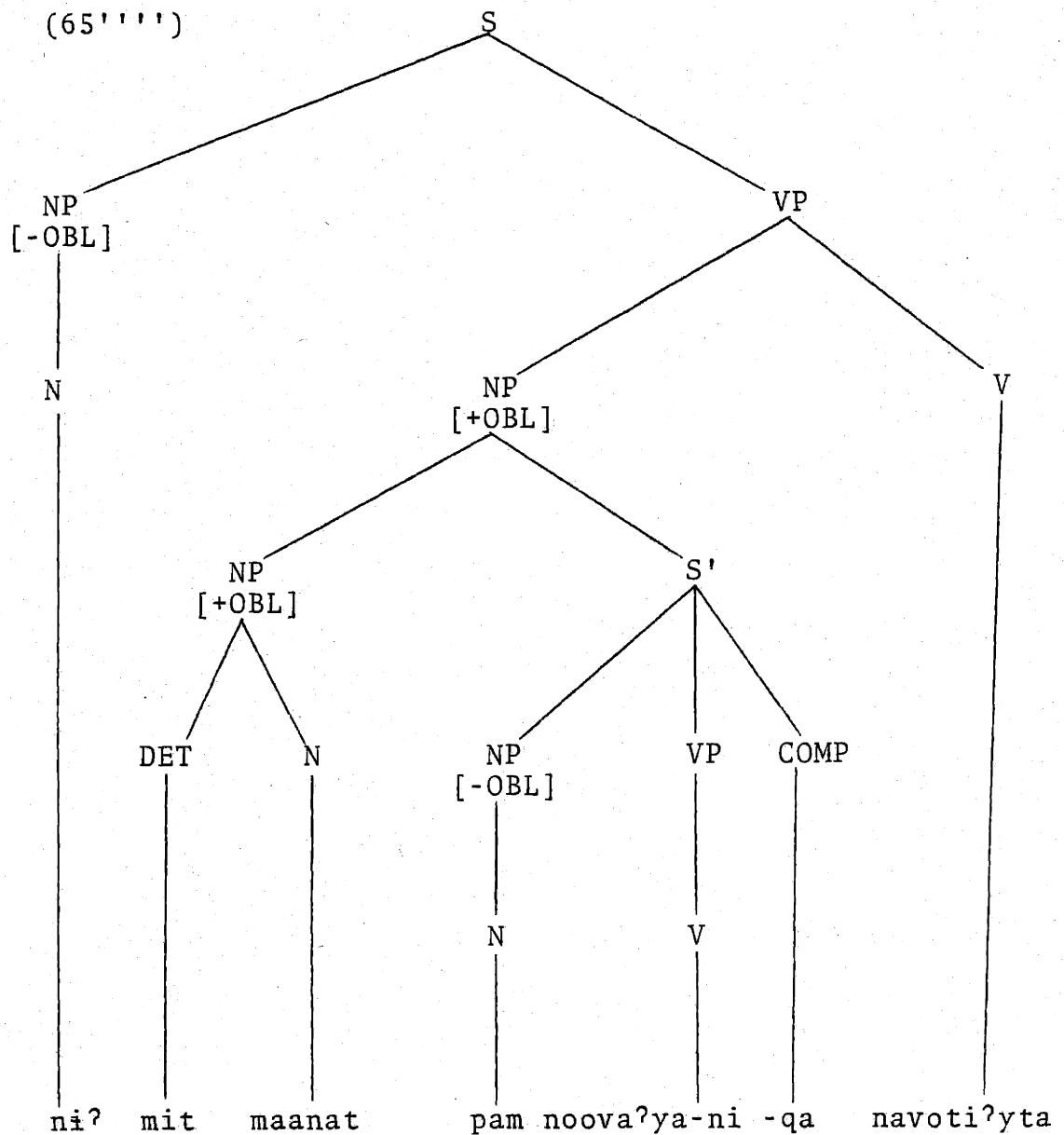

In order to get this result, we must assume that the NP /mi? maana/ in (65) is directly dominated by the superordinate NP-node. In other words, we must assume that it is a pseudo-head. It cannot be a true head because /navoti?yta/



cannot take a concrete NP as its direct object as illustrated by the ungrammatical sentence (59) above. We conclude therefore, that we are correct in assuming that the pseudo-head of a relative clause is in fact merely the NP that appears as the initial constituent in the pleonastic expansion of the NP category.

### 3.6.0. The Nature of Nominalized Sentences and the So-Called Complementizer /-qa/

Let us propose a set of phrase structure rules, expanding the categories S, PP, VP, and the possessive structure dominated by the node NP.

(67)                    S-expansions  
                           S → (NP) S'  
                           S' → NP VP

(68)                    PP-expansions  
                           PP → (NP) PP'  
                           PP' → NP P

(69)

NP-expansions

NP → (NP) NP'

NP' → NP N

(70)

VP-expansions

VP → (NP) VP'

VP' → (NP) ( {<sup>PP</sup><sub>NP</sub> } ) V

In each of these sets of expansions the initial one introduces a pleonastic structure. In (68-70), the final expansion introduces the nuclear constituent of the phrasal category. Thus in set (70), the final expansion introduces the verb, which is the nucleus of the verb phrase; in set (68) the final expansion introduces the postposition which is the nucleus of a postpositional phrase; and in set (69), the final expansion introduces the constituent N which is the nucleus of the NP. Moreover, this nuclear constituent consistently appears in final position in the expansion which introduces it.

The essential observation to be made about these expansions--except for the "root" category S--is that they are consistently endocentric. There is, therefore, a striking parallelism between the three sets of expansion rules for non-root

categories. In particular, the parallelism consists in the virtual identity among the initial expansions and the endocentricity expressed in the final expansion.

Now let us consider the expansions of NP which we have heretofore used to introduce the relative clause,

(71)                    NP-expansion  
                           NP → (NP) S'

This expansion introduces the pleonastic relative clause-- i.e. that which has the pseudo-head--as well as the so-called headless relative clauses. It therefore closely resembles the initial expansions in (67-70).

However, the parallelism with respect to the nuclear constituent is absent in this version of the relative clause expansion. That is to say, while the other phrasal categories are endocentric, the relative clause according to the treatment we have given it heretofore, is not endocentric, unless we regard the pseudo-head as the nuclear structure. This is unlikely for two reasons. First, the pseudo-head is optional and second, its position within the phrase is exactly wrong, from the point of view of the parallelisms among the other phrasal categories.

If we are correct in thinking that the relative clause is introduced by a rule which is parallel to the initial expansions of other non-root phrasal categories, then we should expect the parallelisms to continue in subsequent expansions. Suppose we incorporate the relative clause into the NP expansion by permitting the category S' to appear in the second expansion, as an alternative to NP:

(71')                    NP-expansion (Revised)  
                              NP' → S' N

This expansion replaces that of (71) above. This would achieve the parallelism we seek, however, it raises another question--namely, the question of the identify of the nuclear constituent N appearing to the left of S'. We feel that the answer to this question is in fact the answer to a question which was not explicitly asked, but was nonetheless real, in our earlier analysis. That is, we never seriously posed the following question: what is the proper identity of the element /-qa/? Since it is suffixed to the verb of the embedded clause we have assumed that it is also a constituent of the embedded clause in the underlying structure. Specifically, we have identified it with the universal COMP element, but

our reason for doing this, in the final analysis, must be attributed to our inability to conceive of any other identity for /-qa/.

We would like to suggest now that /-qa/ is a "defective" N which functions as the nucleus in the NP' structure which contains the category S' functioning either as a relative clause, as in the majority of the sentences cited in this paper, or as a sentential complement of the type represented in the sentences (64) and (65). We cannot at this point fully elaborate this hypothesis but we nonetheless feel that it is promising and that it will ultimately prove to be correct.

Although the /-qa/ element appears as a suffix to the subordinate verb in surface structure, it nonetheless shares morphological properties with full nouns--i.e. it inflects for case and also for number. And although it consistently appears as /-qa/--and is in that sense defective--there is some indication that we must distinguish between a /-qa/ which is [+CONCRETE] and one which is [-CONCRETE]. The latter functions as a head N in the abstract sentential complements of verbs like /navoti?yta/. The former functions as the head of what we have termed the relative clause, and is construed with a concrete NP appearing in the relative clause itself.

The distinction between the [+Concrete] and [-Concrete] /-qa/ can be observed in the following two sentences:

(72) ni? mi-mi-y            totimhoy-mi-y (pima)  
 (I    that-NSG-OBL boys-NSG-OBL    they  
       timala?yyiŋ-qa-mi-y tiwi-mi-?yta  
       work-qa-NSG-OBL        know-NSG-?yta)  
 'I know the boys that are working.'

(73) ni? mi-mi-y            totimhoy-mi-y (pima)  
 (I    that-NSG-OBL boys-PL-OBL        they  
       timala?yyiŋ-qa-t navoti?yta  
       work-qa-OBL            know)  
 'I know that the boys are working.'

In the first sentence, the /-qa/ is marked for non-singular number--and therefore appears as /-qa-mi/--in accordance with the fact that it is construed with the plural subject in the embedded clause. This is the [+Concrete] /-qa/. In the second sentence, the /-qa/ is [-Concrete] and therefore is not construed with an NP in the subordinate clause; it is treated as grammatically singular.

It seems reasonable to assume that it is not only the /-qa/ element which is designated [<sub>±</sub> Concrete] but that the entire complex NP is assigned this feature. So we will assume that the superordinate NP-node is provided with these features

as well. This will permit us to characterize the selection of verbs which are sensitive to this feature in the simplest possible way. Thus, for example, the verb /navoti?yta/ will be defined as appearing in the frame,

NP  
[-Concrete]\_\_\_\_\_

while the verb /tiwi?yta/ (non-singular /tiwimi?yta/) appears in the frame,

NP  
[+Concrete]\_\_\_\_\_

The underlying structures of Ss (72-73) and their derivations are given below. (We assume that the concrete NP's are supplied with the number features as well as the concreteness features.)

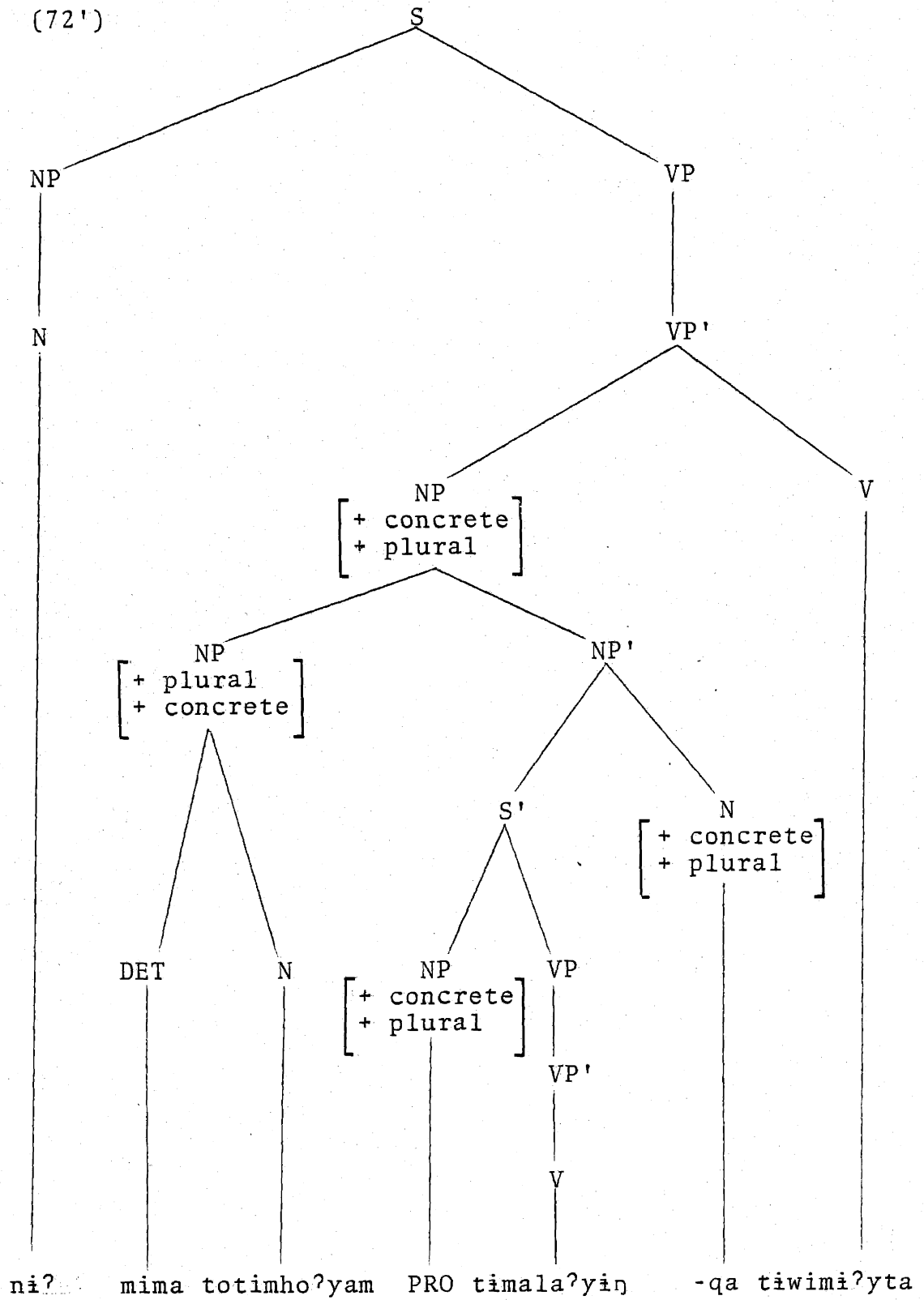



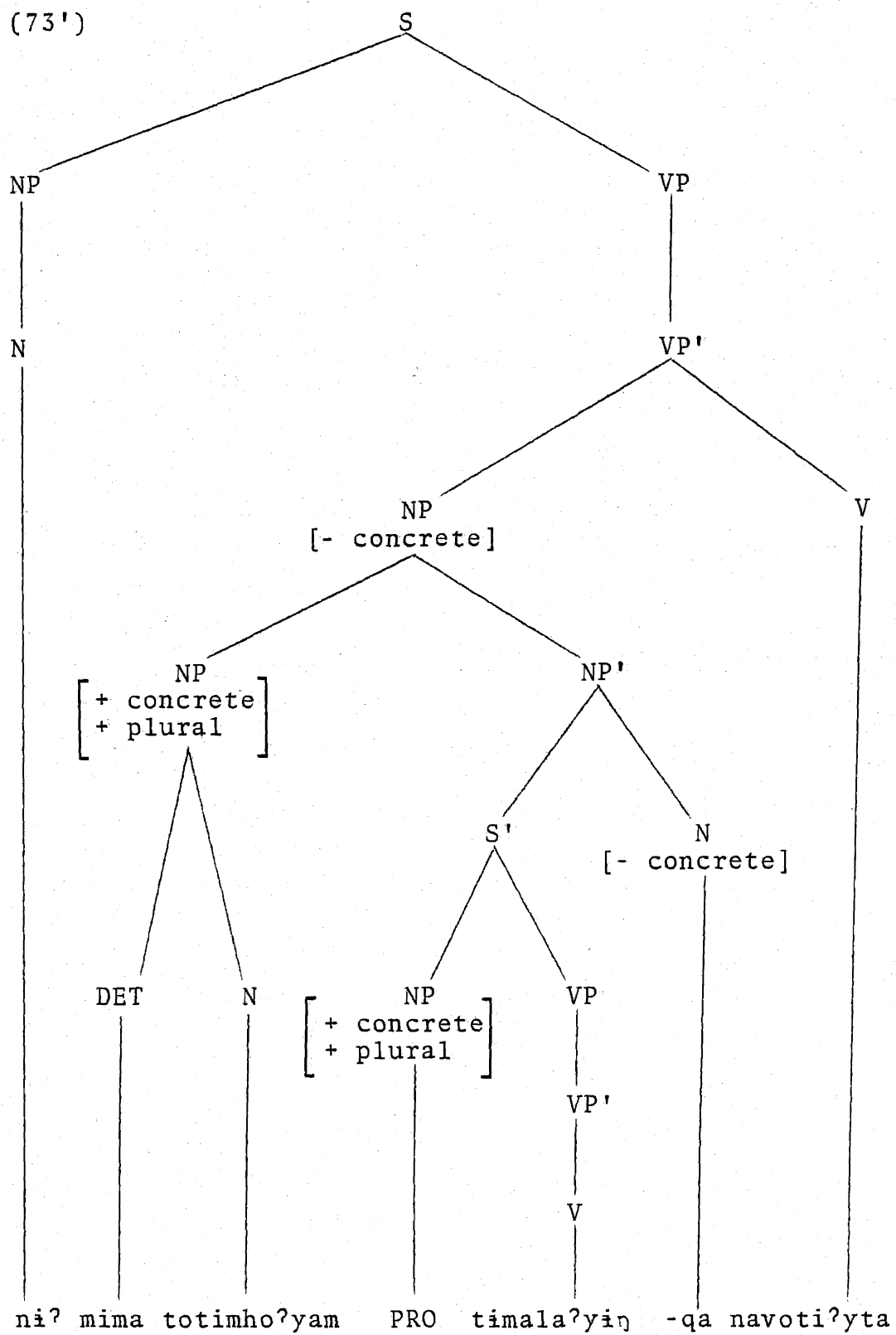

NP-Case Assignment applying to (72') and (73') respectively, gives,

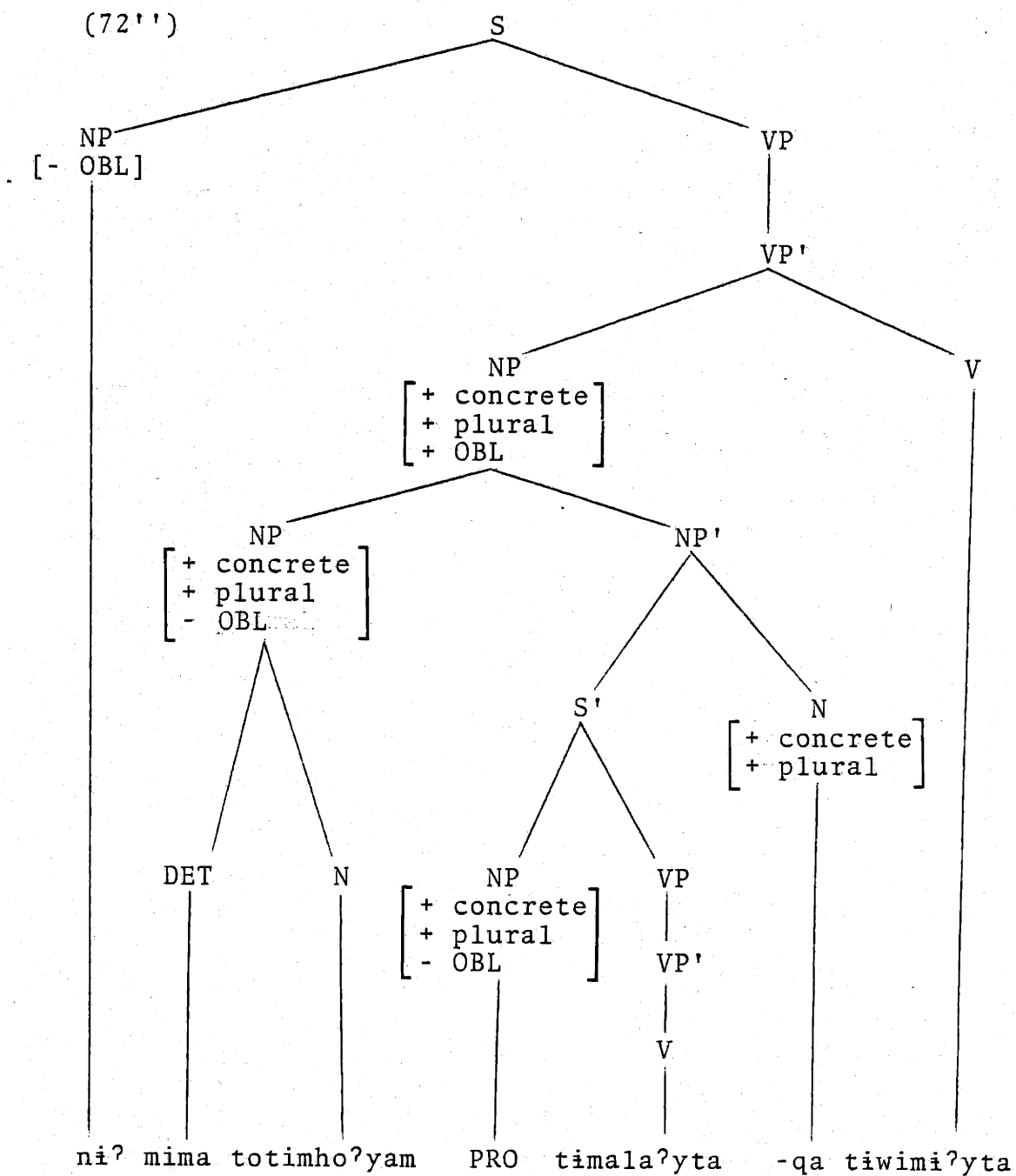

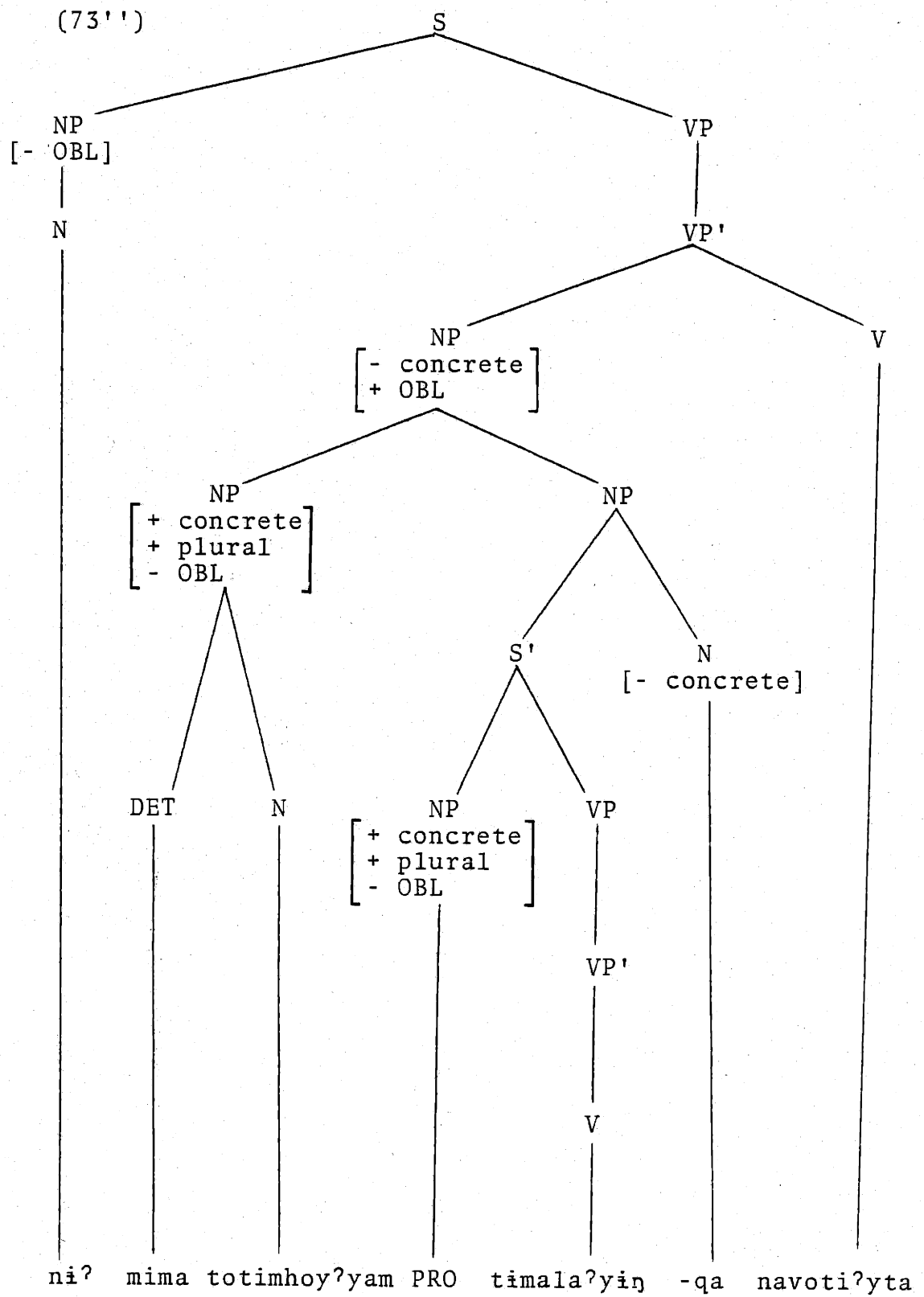

Case Concord applies next, making the pseudo-head NP-node [+ OBL] in (72'') and (73''), giving, respectively,

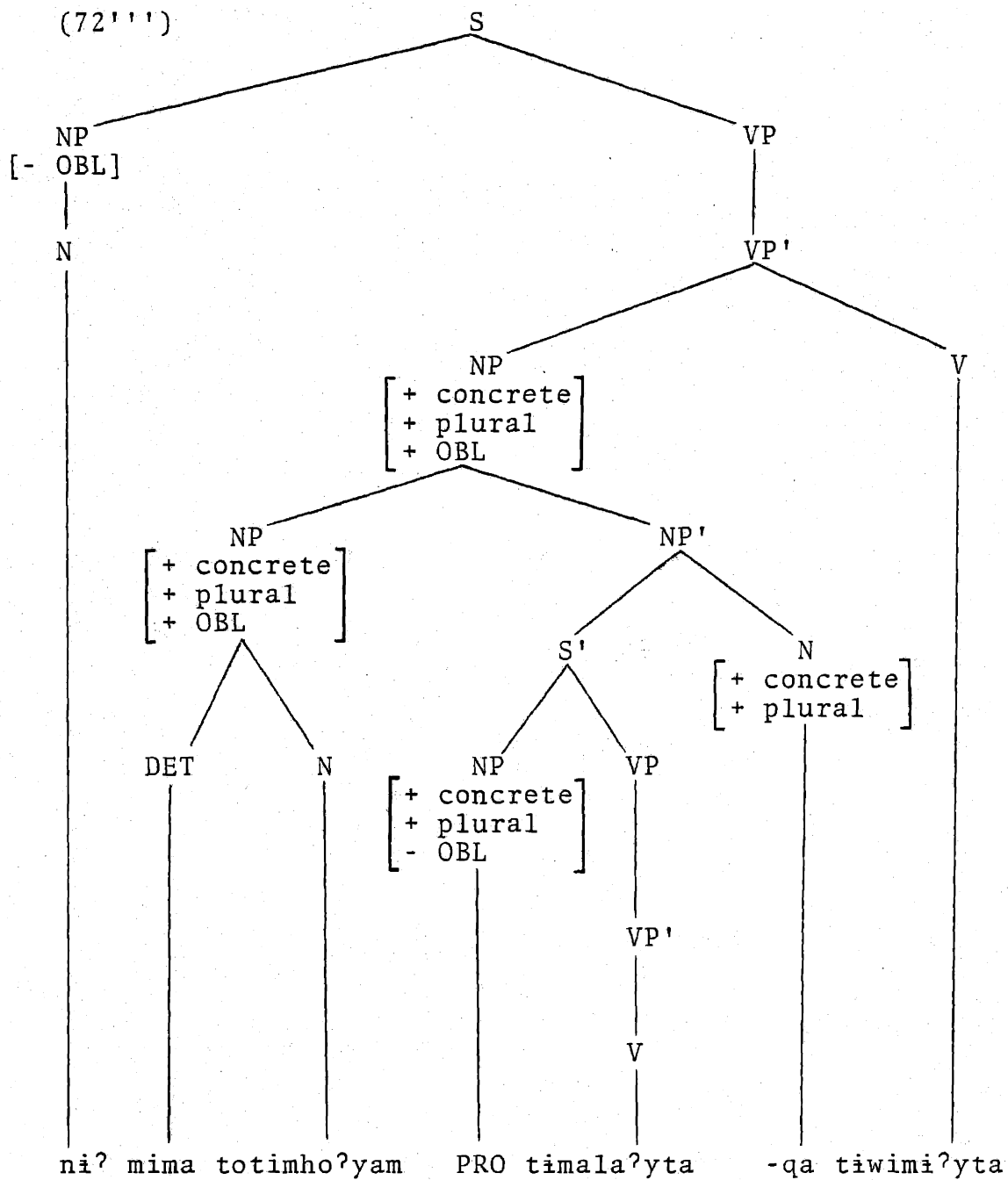

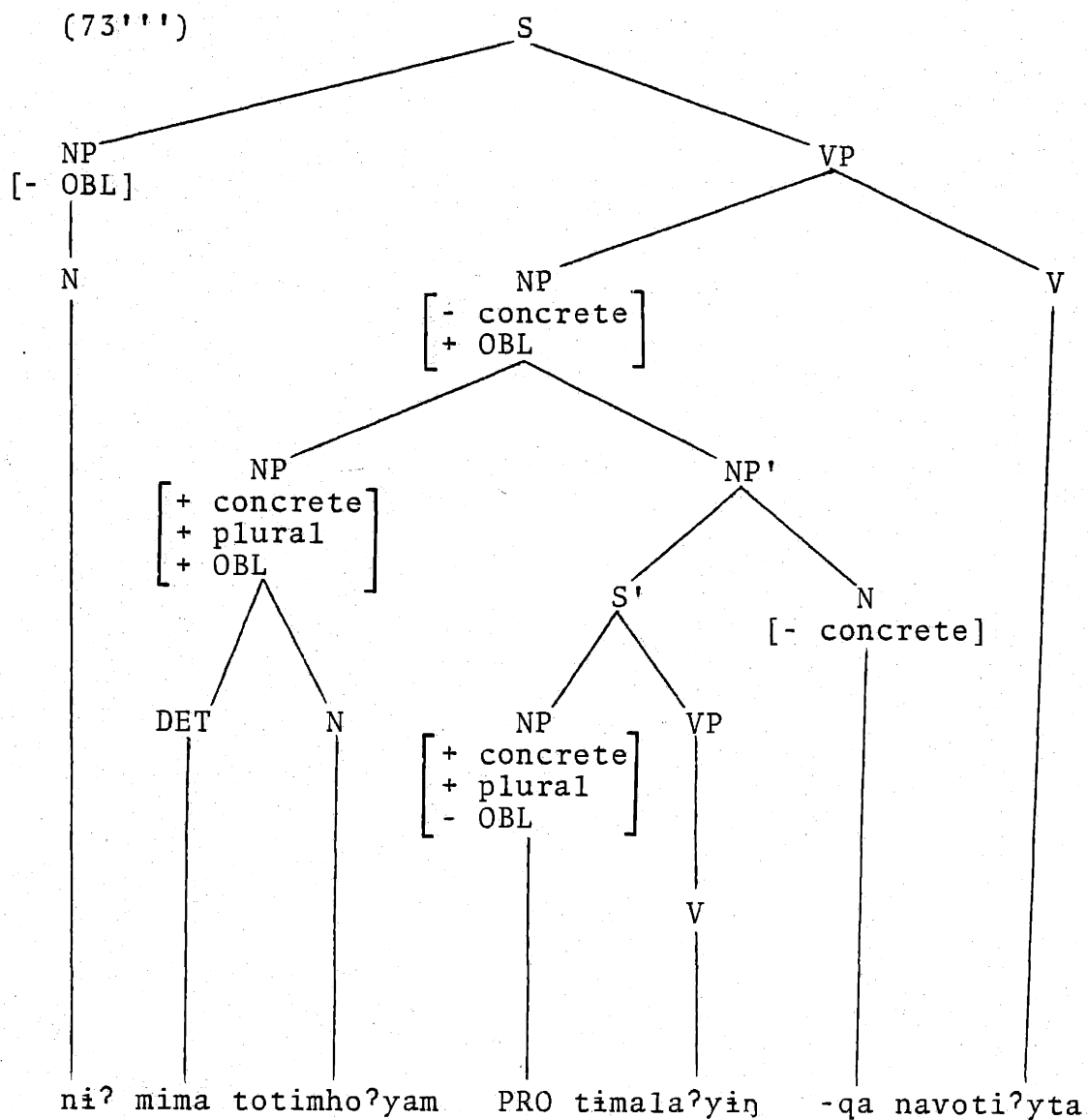

Finally, the head N /-qa/ appears as /-?qa-mi-y/ in (72) in accordance with the principle of QA-Case Assignment for non-singulars, giving, ultimately,

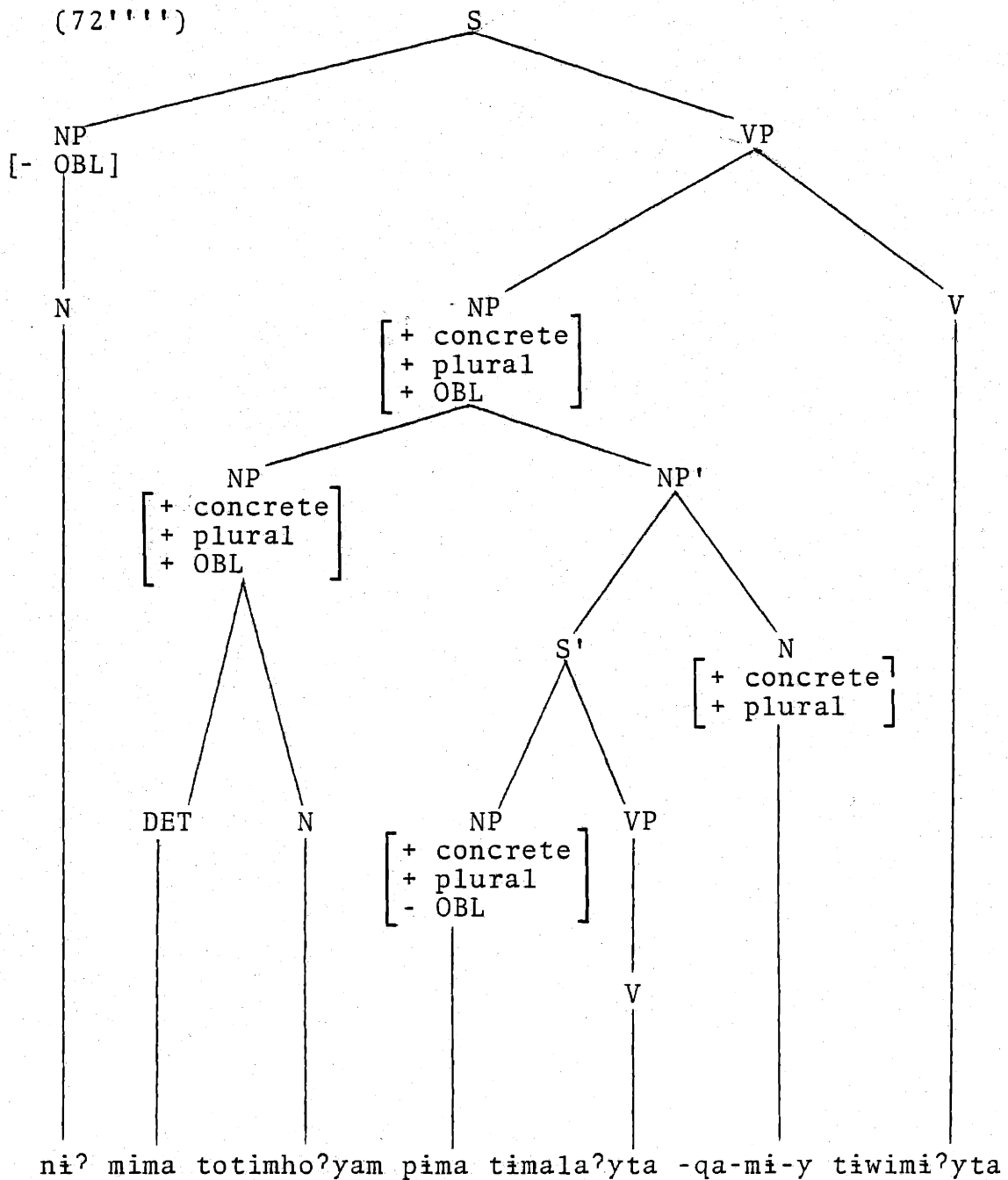

In (73) QA-Case Assignment applies, giving ultimately,

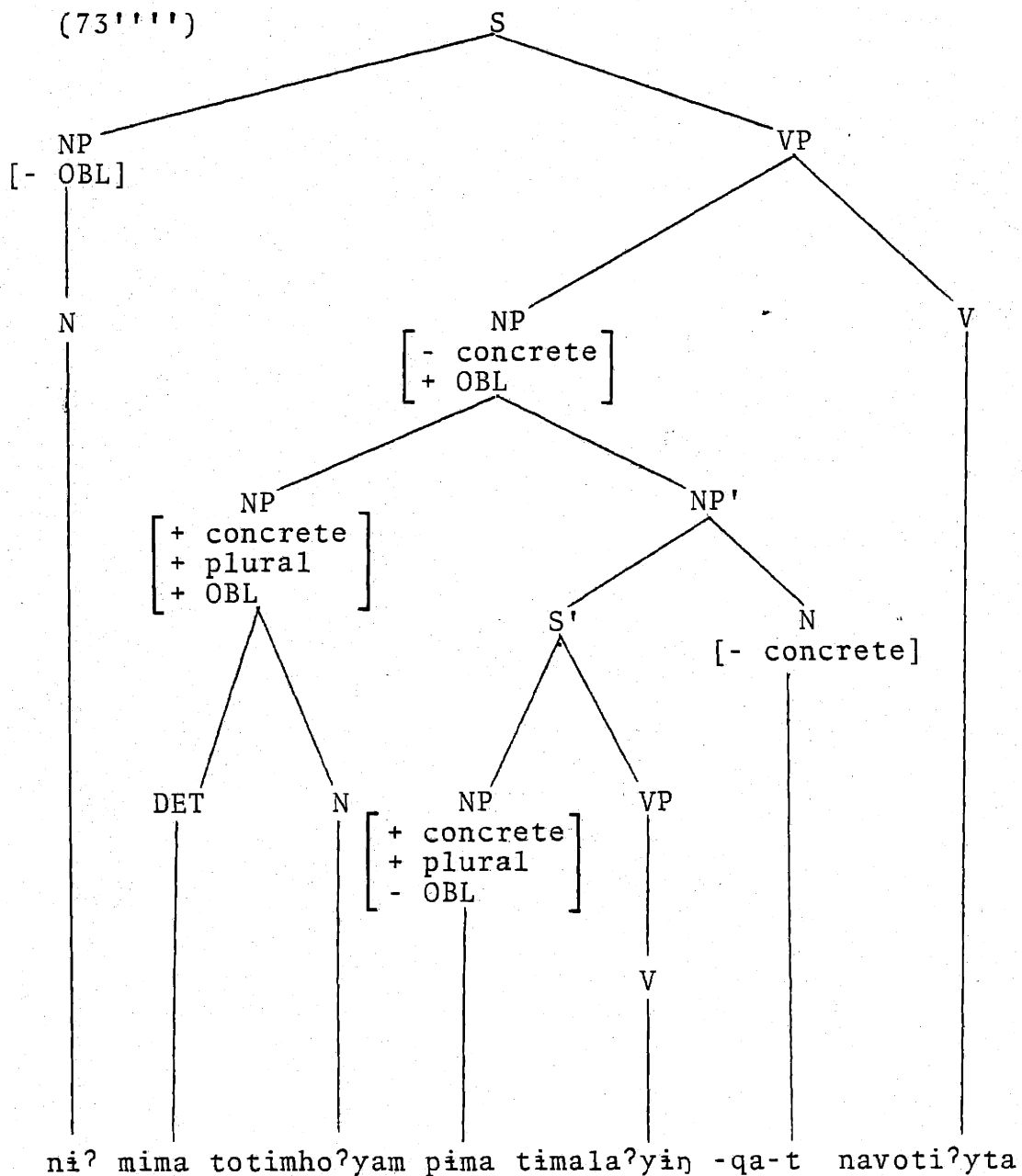

The distinction between [+ concrete] and [- concrete] complex NP's also manifests itself in pronominalization. It is possible to render the two Ss, (72-73), in another way--

i.e. there is a version in which the complex NP appears to the right of the verb and in which a pronoun construed with the complex NP appears in the pre-verbal position. Thus, we have Ss corresponding to (72-73),

(72a) ni? pi-mi-y tiwi-mi?yta, mi-mi-y totimhoy-mi-y  
(pi-ma) timala?yyiŋ-qa-mi-y

(73a) ni? pi-t navoti?yta, mi-mi-y totimhoy-mi-y  
(pi-ma) timala?yyiŋ-qa-t.

We might assume that these Ss are derived by means of a rule of extraposition which follows Case Concord, thereby accounting for the oblique case on the pseudo-head, and which leaves a pronominal copy behind in the original pre-verbal position. This pronominal copy is sensitive to the concreteness feature of the complex NP. In the first S, the complex NP is [+ concrete] and the head NP is plural, therefore, the pronoun left behind is non-singular. In the second S, on the other-hand, the complex NP is [- concrete] and is treated as grammatically singular; the pronoun copy is therefore singular. This behavior incidentally tends to confirm our suspicion that



the NP /mimiy totimhoymiy/ is not the true head of the complex NP since it does not determine the number category associated with the structure as a whole.

The same behavior can be observed in the following Ss in which the complex NP appears in 'topic' position by virtue of the rule

(74)  $S \rightarrow NP S'$

In this case, there will be a pronoun in S' corresponding to the complex NP as a whole and the number category observed in the pronoun will follow the same principle:

(75) mi-ma          totimho<sup>?</sup>ya-m, (pi-ma)  
 (those-NSG boy-NSG          they-NSG  
 timala<sup>?</sup>yyiŋ-qa-mi-y, ni<sup>?</sup> pi-mi-y          tiwimi-yta  
 work-qa-NSG-OBL,          I          they-NSG-OBL know)  
 'Those boys that are working, I know them.'

(76) mi-ma            totimho?yam, (pi-ma)    timala?yyin-qa-t,  
       (those-NSG boy-NSG            they-NSG work-qa-OBL,  
       ni? pi-t    navoti?yta  
       I    it-OBL know)  
       'Those boys, that they are working, I know it.'

The details of this analysis remain to be worked out but we hope we have presented enough of a skeleton to show at least one direction which seems promising.

### 3.7.0. Conclusions and Summary

We began this chapter with a consideration of certain facts which led to the postulation of the so-called "Subject Constraint" on the formation of relative clauses in Hopi. In order to explain these facts, rather than simply be satisfied with a rather unnatural constraint on a rule of grammar, we briefly considered an alternative to the initial analysis which involved a 'headed' relative clause structure. This alternative assumed an underlyingly 'headless' relative clause structure and a 'raising' rule, applying cyclically--and therefore after case assignment on the embedded cycle--which extracted a NP, leaving a pronominal copy behind, and positioned it in 'head' position to the left of the embedded clause. The ill-formedness of sentences of the type repre-

sented by (29) was to be accounted for in terms of a surface failure in concord. The initial plausibility of this analysis was bolstered by the observation that, indeed, headless relative clauses--i.e. relative clauses missing the NP on the left of the embedding--do exist as an alternative in Hopi.

However, upon the consideration of further data in Hopi, it became evident that the raising analysis would not, in fact, work. The pleonastic or 'topicalized' sentence (40) shows, for example, that apparent failures in concord are, in fact, grammatical, under appropriate circumstances. More importantly, however, sentences of the type represented by the pleonastic (40) and (43) revealed that the marking of relative clauses--that is to say, the assignment of endings to the /-qa/ element--is governed not by the ordinary case-marking principles applicable to NP's but rather by the principle of obviation, which virtually dominates Hopi grammar. We also adduced evidence showing that the NP appearing in left-head position is not, in fact, a head in the strict sense. Rather, it is a special case of the 'topic' in pleonastic structures, a type which, in Hopi, generalizes to all phrasal categories. The true head of a relative clause, we contend, is the 'defective' noun /-qa/ which appears as an enclitic to the embedded sentence, or rather to the verb of the embedded sentence.

Our hypothesis as a whole involves the following

mechanisms:

- (77) (i) NP-Case Assignment (cf. (55))  
 (ii) Case Concord (cf. (56))  
 (iii) QA-Case Assignment (cf. (45))  
 (iv) A surface structure constraint or filter ruling out obliquely marked NP in subject position (cf. (53)).

The ordering given in the above listing is not to be taken as an extrinsic ordering required in the grammar. There is, of course, an intrinsic ordering relationship between (i) and (ii), and, of course, the surface filter cannot apply relevantly unless structures are fully marked. An additional remark, in the same vein, should be made concerning these principles of grammar. The 'rules' (74 i-iii) have been formulated in a way which might be taken to imply that we are confident of their exact nature. This is not the case. Rather, our formulation should be regarded simply as a mechanical procedure for effecting surface forms in accordance with certain principles of grammar--it is the latter, namely the principles, that seem to us to be real, not the formulation. Thus, for example, we imply that cases are assigned by a rule;

i.e. we imply that they are not present in underlying syntactic representations at the base and that, at some point in derivation, they are inserted into structures. This may, of course, be wrong. It may be, for example, that cases are assigned as a part of the word-formation apparatus in the lexicon, irrespective of syntactic structure, and that the principles we seek to capture in (77 i-iii) above are properly a part of the interpretive component. In the next chapter, for example, we study a principle of Hopi grammar--i.e. obviation--which quite clearly assumes the latter.

All of the principles (77 i-iv) involve case marking, in one way or another. However, they are distinct principles. The first, as its name implies, is concerned with the gross matter of ensuring that noun phrases are appropriately associated with the oblique case category in accordance with their syntactic position within clauses. Case Concord, on the other hand, is concerned with the Hopi requirement that the immediate constituents of a noun phrase be marked to agree in case, in accordance with the case category assigned to the noun phrase as a whole--notice that this is a local morphological adjustment, familiar enough from other languages, but not one that is necessarily associated with a language which has case assignment; some languages have it (Hopi, Lardil of North Queensland, Russian, etc.), while others do not (Basque, Walbiri of Central Australia), but rather mark the whole NP

once and for all for the case category. Case Concord is, therefore, to be distinguished from Case Assignment.

The principles of QA-Case Assignment are to be kept rigidly distinct conceptually from the previous two rules. To be sure, QA-Case Assignment involves the oblique endings [-t] and [-y], but it does not involve their assignment in the sense of (74-i). Rather, it is a special case of obviation.

Finally, the principle embodied in (77-iv) is recognized as being a filter explicitly. It interacts with other principles of Hopi grammar in the following way. The rule of QA-Case Assignment, as we have seen, will in some applications result in the circumstances that a complex noun phrase in subject position (i.e. directly before VP) terminates in the oblique ending. This is in defiance of the prevailing surface fact of Hopi that noun phrases in subject position are unmarked for case. We suggest that the ill-formedness of sentences like (47) is due to the fact that they violate this otherwise general principle of surface structure case marking. In this conception of Hopi grammar, then, there is no need for the very unnatural Subject Constraint (3). The surface filter, by contrast with (3), is extremely natural--it can quite reasonably be viewed as a case of Kiparsky's 'opacity' (1973 pp. 57-86), in the sense that a sentence like (47), which violates the filter, can be thought of as making the general

principle of case assignment opaque--i.e. not 'surface-true'. It is, perhaps, an indication of the correctness of this approach that, like many conditions whose purpose is to avoid making a rule opaque, it is not universal for all dialects--opaque rules are, after all, tolerable; and it would not be surprising to find a Hopi dialect in which the filter (53 = 77 iv) is lacking and in which, therefore, a sentence of the type represented by (47) would be fully acceptable. Such a dialect does, in fact, exist. The Second Mesa dialect represented in the recent pedagogical grammar of Hopi by Milo Kallactaca (1978) evidently lacks the filter and admits as acceptable sentences of the general form of (47). In that dialect, therefore, the Subject Constraint would never have been entertained, since relativization of a subject would never have presented the problem which we faced in the Third Mesa dialect under investigation here.

## CHAPTER 4

## THE HOPI RULE

4.0. Introduction

We deal now with a topic generally subsumed under several terms; anaphora, pronominalization, and coreference. Specifically, we would like to characterize as precisely and as succinctly as possible, the conditions under which a pronoun must or must not be coreferential with a full noun phrase in Hopi. This will involve a more explicit account of Hopi obviation. Thus, for example, we will deal with sentences like the following:

- (1) mi? tiyo?ya paki-t      pii? pam qatiiti  
 (that boy      enter-PROX then he sat:down)  
 'The boy entered, then he sat down.'

Here, the noun phrase /mi? tiyo?ya/ is necessarily interpreted as coreferential with the pronoun /pam/. On the other hand, in the sentence,



- (2) mi? tiyo?ya paki-q pii? pam qatipti  
 (that boy enter-OBV then he sat down)  
 'The boy entered, then he sat down.'

the full noun phrase /mi? tiyo?ya/ must not be coreferential with the pronoun /pam/. There are also cases in which there can be coreference--i.e. in which coreference is 'free' (as in (4) below).

#### 4.1.0. The Non-Coreference Rule

We begin by asking the following question. When can a pronoun refer to some other noun phrase? It appears that free coreference in Hopi is governed by the now familiar Precede-and-Command principle. We adopt the Non-Coreference Rule of Lasnik (1976):

#### (3) The Non-Coreference Rule

If NP<sub>1</sub> precedes and commands NP<sub>2</sub>, and NP<sub>2</sub> is not a pronoun, NP<sub>1</sub> and NP<sub>2</sub> are non-coreferential.

Thus, for example, consider the following facts:

- (4) ?i-pava<sub>i</sub> mi-t tiyo?ya-t [(pam) pi-t<sub>i</sub>  
 (my-brother that-OBL boy-OBL (he) him-OBL  
 ?a-mim timala?yta-qa-t] hoona  
 him-with work-qa-OBL sent:home)  
 'My brother<sub>i</sub> sent home the boy that works with him<sub>i</sub>.'

- (5) \*pam<sub>i</sub> mi-t tiyo?ya-t [(pam) ?i-pava-y<sub>i</sub>  
 (he that-OBL boy-OBL (he) my-brother-OBL  
 ?a-mim timala?yta-qa-t] hoona  
 him-with work-qa-OBL sent:home)

(Subscript indexical letters indicate coreference.) In (4),  
 /?i-pava-y/ must be non-coreferential, as predicted by (3).

Consider how the same rule applies to simplex sentences.

The sentence,

- (6) \*pam<sub>i</sub> mi-t tiyo?ya-t<sub>i</sub> wiva?ta  
 (he that-OBL boy-OBL hit)  
 'He<sub>i</sub> hit that boy<sub>i</sub>.'

is presumably ungrammatical because it is a violation (3).

This is exactly right. But consider now a construction in which the pronoun follows the full noun phrase, as in,

- (7) mi? tiyo?ya<sub>i</sub> pi-t<sub>i</sub> wiva?ta  
 (that boy him-OBL hit)  
 'That boy<sub>i</sub> hit him<sub>i</sub>.'

Notice that the rule embodied in (3) above says nothing about sentence (7), implying that it is well-formed on the coreference reading. The Hopi facts, however, are otherwise. Sentence (7) is ill-formed on the reading where coreference is intended,

- (8) \*mi? tiyo?ya<sub>i</sub> pi-t<sub>i</sub> wiva?ta .

How do we block coreference in a sentence like (7)? As an initial guess, we might say that a pronoun cannot be coreferential with another noun phrase in the same clause. This presumably is the reason why sentence (9) is ill-formed:

- (9) \*mi<sup>?</sup> tiyo<sup>?</sup>ya<sub>i</sub> pi-t<sub>i</sub> tooci-y-at sak<sup>w</sup>ita  
 (that boy him-OBL shoe-OBL-OBV break)  
 'That boy<sub>i</sub> wrecked his<sub>i</sub> (own) shoes.'

In other words, /mi<sup>?</sup> tiyo<sup>?</sup>ya/ and /pi-t/ in sentence (9) cannot be coreferential.

Now, however, the following example has to be accounted for:

- (10) ni<sup>?</sup> taaqa-t<sub>i</sub> pi-t<sub>i</sub> sikisve-y-at <sup>?</sup>a-wq pana  
 (I man-OBL his-OBL car-OBL-OBV it-into put)  
 'I put the man<sub>i</sub> into his<sub>i</sub> (own) car.'

The structure of (10) is roughly as follows:

(10')

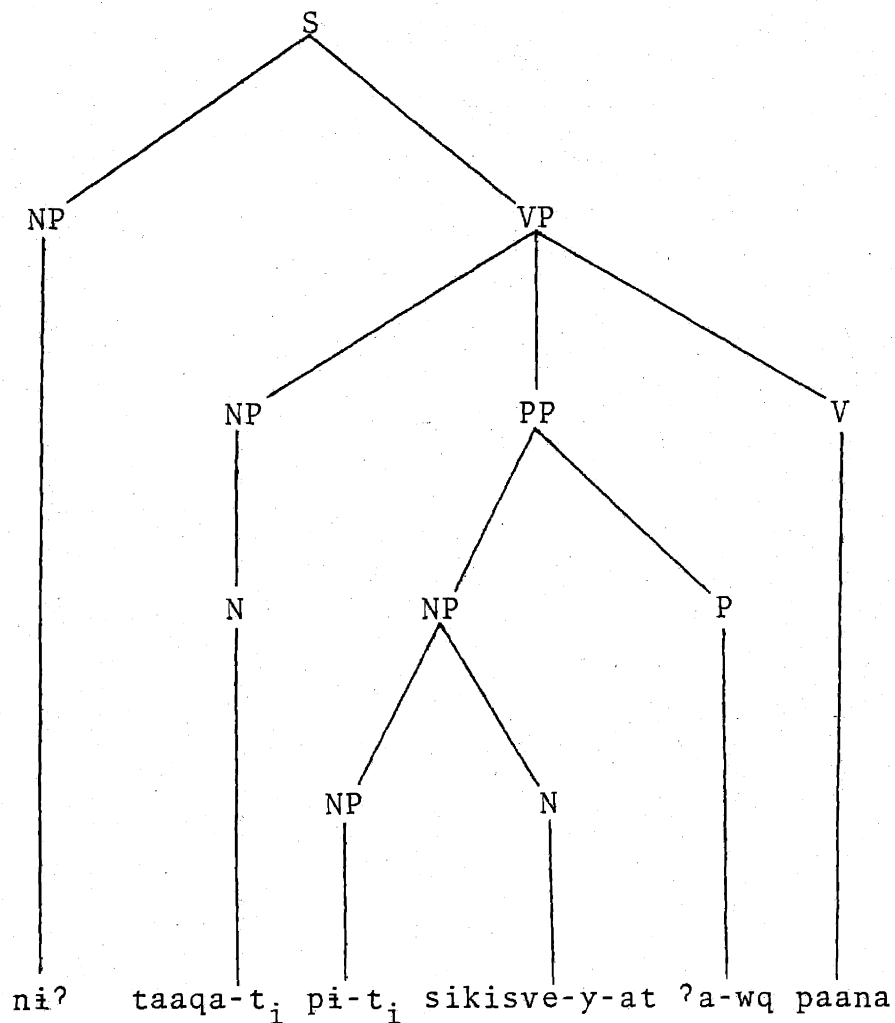

Here, /taaqa/ and /pit/ can be coreferential although they are in the same clause. Apparently other mechanisms are needed to explain the above facts.

#### 4.2.0. Disjoint Reference

Let us switch strategies here, and rather than talk about a noun phrase being coreferential with another noun

phrase, let us assume instead a rule of Disjoint Reference. It states roughly:

- (11) Disjoint Reference  
 An NP is [-COREF] with any other NP.

(This formulation is one of the sub-effects of a principle which Postal called the Inclusion Constraint (Postal, 1974, p. 77). It is later formulated by Chomsky in "Conditions on Transformations" where it is referred to simply as Rule of Interpretation (1973).) The effect of Disjoint Reference is that it makes every noun phrase non-coreferential with other noun phrases in a given structure. Notice that it will give us exactly the right results for what was a problem earlier, namely, (7)--repeated here as (12):

- (12) mi? tiyo?ya<sub>i</sub> pi-t<sub>j</sub> wiva?ta  
 (that boy him-OBL hit)  
 'That boy<sub>i</sub> hit him<sub>j</sub>.'

Disjoint Reference says that the noun phrase /mi? tiyo?ya/ is

[-coref] with any other noun phrase--including a noun phrase consisting of a pronoun, as in (12). This is exactly right.

If we assume a rule of Disjoint Reference, a problem would be a case where coreference is possible. For example, consider sentence (13)--given with its phrase marker:

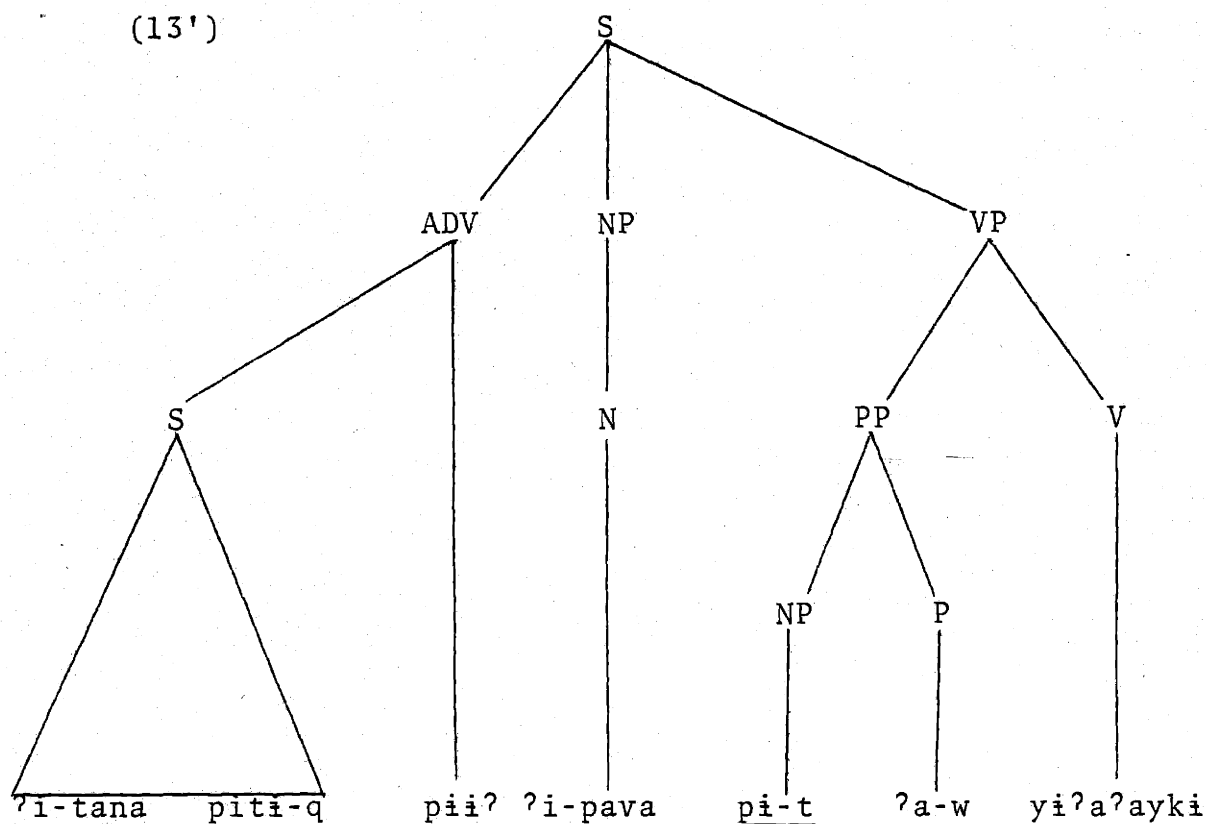

(my-father arrive-OBV then my-brother him-OBL him-to speak)

'When my father came, my brother talked to him.'

The noun phrases that concern us here are those that are under-

lines (henceforth, we use this mechanism to identify the noun phrases under discussion). Disjoint Reference disallows coreference between /pit/ and /ʔitana/--and, in fact, the disjoint reading is one that is possible and one which we would want to allow. However, in Hopi--as is also true in the corresponding English sentence--a second reading obtainable from (13) is the coreference one, i.e. that where /ʔitana/ and /pit/ are coreferential. How is coreference allowed in (13)?

We would like now to make use of the Tensed-S Condition (Chomsky, 1973 p. 238) to give us the desired results:

(14) Tensed-S Condition (our version)

No rule may relate X and Z or Y and Z, where  
 $\alpha$  is a tensed S: ...X... [ $\alpha$ ...Z...] $\alpha$ ...Y...

Returning to (13), notice that /ʔitana/ is within an embedded tensed sentence, /ʔitana pitiq/, and /pit/ is outside of it. Therefore, the Tensed-S Condition blocks the application of Disjoint Reference, hence /ʔitana/ and /pit/ can be coreferential.

Now, however, consider the following sentence:



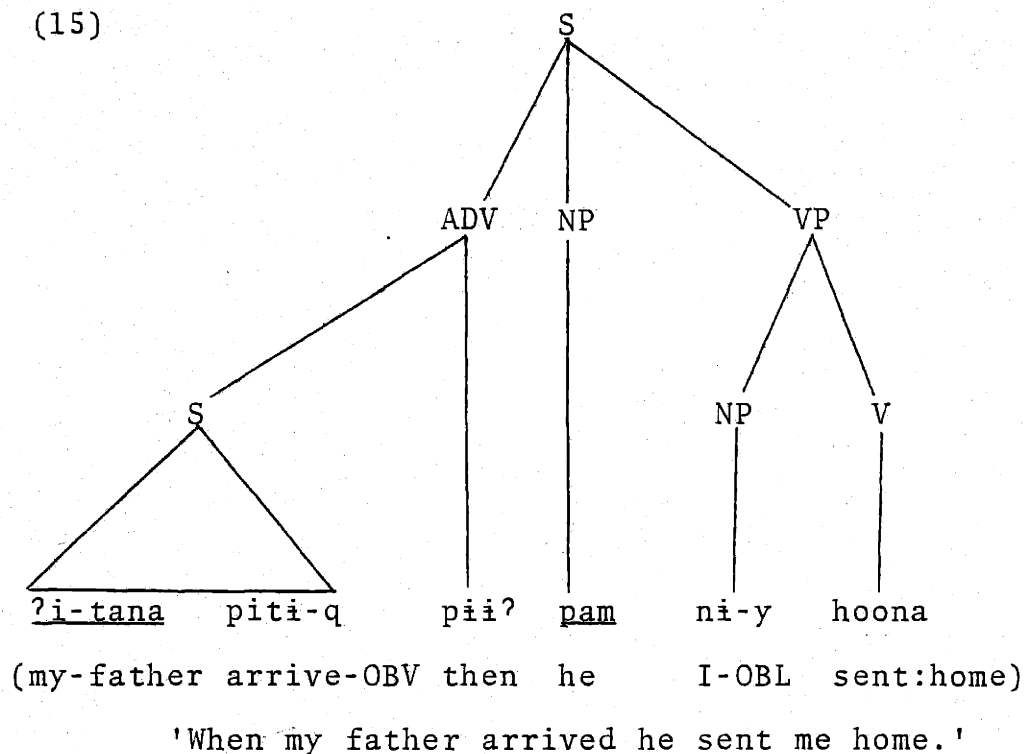

Sentence (15) is an example where coreference cannot be allowed between /?itana/ and /pam/--this is unlike (13) where ambiguity, i.e. free coreference, is observed. Notice that Disjoint Reference will give us exactly the right result. However, we now have the Tensed-S Condition. It will block application of Disjoint Reference, thereby allowing a coreference reading for (15).

#### 4.2.1. A First Hopi Rule

It seems Disjoint Reference and Tensed-S are not enough to explain all the facts. We maintain that there is an addi-

tional mechanism operative in Hopi--to wit, obviation. In (15), notice what happens when the /-q/ conjunction is changed to /-t/ giving,

(16) [ʔi-tana piti-t] piiʔ pam ni-y hoona

Here /ʔitana/ and /pam/ must be coreferential. Hence, obviation is determining the anaphoric relationship--/-q/ is the obviative conjunction and /-t/ the proximate. We would like to suggest the following Hopi rules which state necessary coreference and noncoreference:

(17) Hopi Rule (a)

The subject of a dependent clause marked as obviative must be [-coref] with the subject of the main clause.

Hopi Rule (b)

The subject of a dependent clause marked as proximate must be [+coref] with the subject of the main clause.

These rules are posited to account for the obviation phenomenon. Notice that with the Hopi rules, we have no problem explaining sentences (15-16). Notice also that the Hopi Rules (a) and (b) can be collapsed into a single rule using the 'alpha' notation (and using [prox] to represent the feature corresponding to the obviation opposition).

(18) Hopi Rule 1

The subject of an [αprox] dependent clause is [αcoref] with the subject of the main clause.

Note that, if we understand the expression 'dependent clause' to include relative clauses terminated by the defective noun /-qa/, variously marked for obviation, then Hopi Rule 1 will account for the coreference facts illustrated by (45i-iii) in Chapter 3 above.

4.2.2. A Second Hopi Rule

Consider now the following structure:

(19)

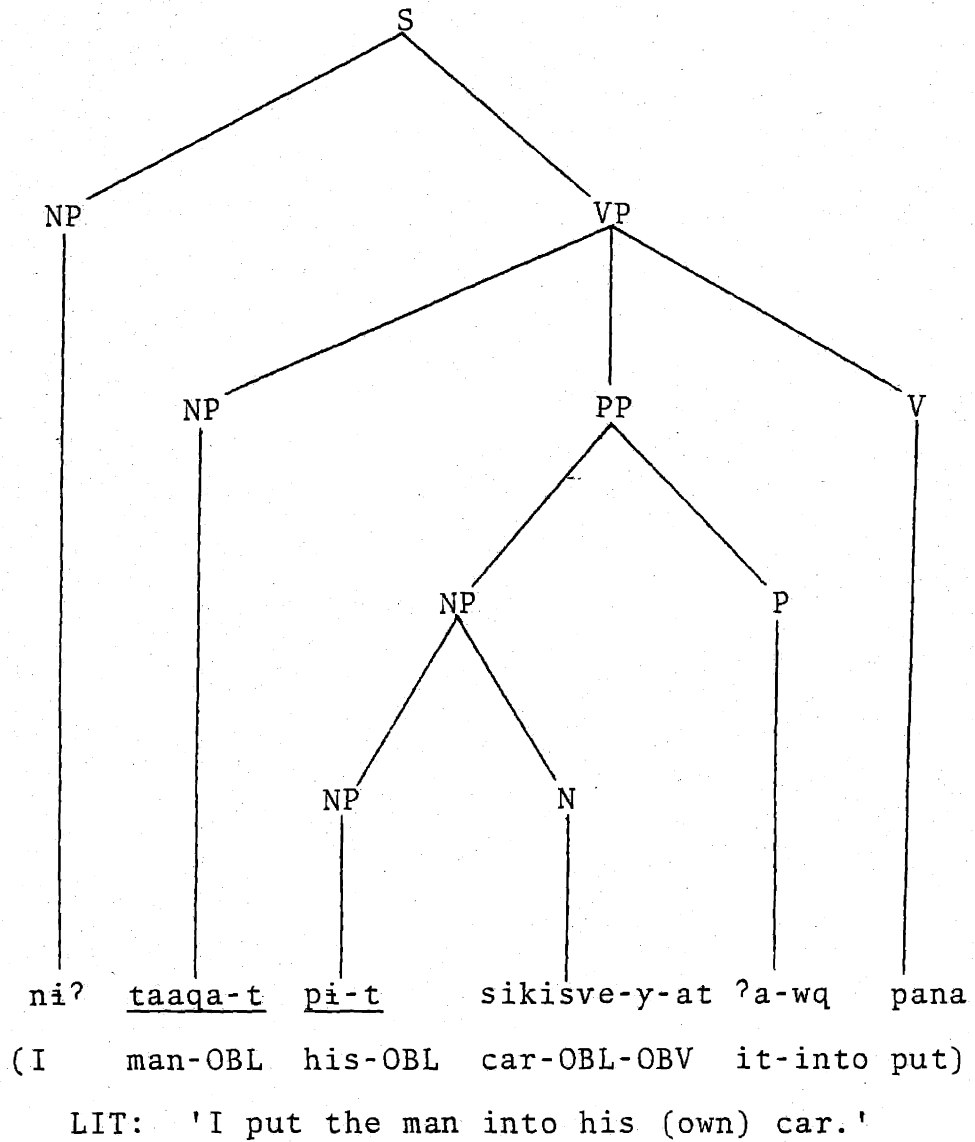

In (19) /taaqa/ and /pit/ can also be coreferential; however, Disjoint Reference will block coreference. How can one get coreference here?

We might make use of the A-over-A principle to block Disjoint Reference, thereby allowing coreference. The A-over-

A principle reads as follows:

(20) A-over-A (Chomsky, 1973, p. 235)

If a transformation applies to a structure of the form [ <sub>$\alpha$</sub> ...[<sub>A</sub>...]...] where  $\alpha$  is a cyclic node, then it must be so interpreted as to apply to the maximal phrase of the type A.

Since /pit/ is a noun phrase which is a constituent of a larger noun phrase, it is exempt from Disjoint Reference. This is probably an incorrect move, since it is very unlikely that the A-over-A principle is relevant here; rather, its relevance is probably limited to movement transformations. This issue is beside the point in Hopi as we will see shortly.

Consider now the following example:

(21)

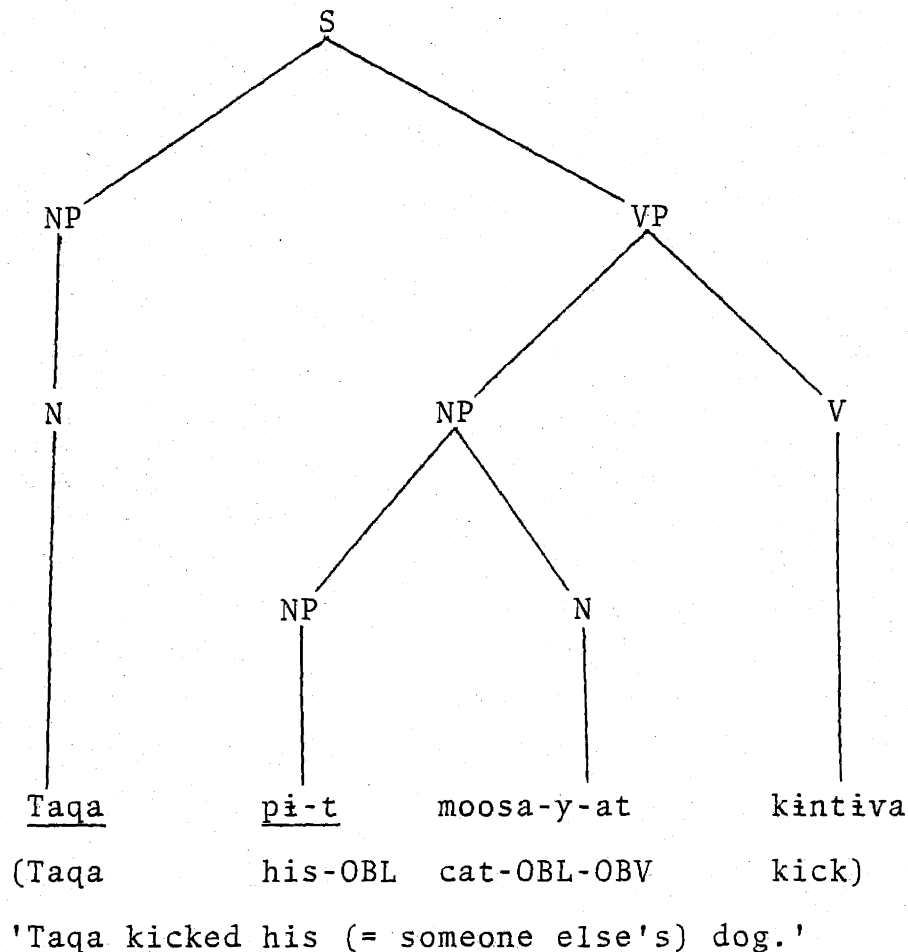

In (21) /taqa/ and /pit/ cannot be coreferential. Once again, Disjoint Reference would give the correct result. However, A-over-A will block its application. How do we allow non-coreference in (21)?

Recall the possessive constructions discussed in Chapter 2, section 2.3.. In particular, recall the sentences, (68 a & b), repeated here as (22) and (23) respectively,

- (22) mi? taaqa po?ko-y-at niina  
 (that man dob-OBL-OBV kill)  
 'That man killed his (= someone else's) dog.'

- (23) mi? taaqa po?ko-y niina  
 (that man dog-OBL kill)  
 'That man killed his (= own) dog.'

These sentences, as we indicated earlier, illustrate the obviation principle. Sentence (22) is an example of obviative possession--overtly marked by the suffix [-(? )at]--while (23) is an example of proximate possession, reflected by the absence of a possessive suffix. Returning to example (21), if [-at] is left off /moosa-y-at/, giving /moosa-y/, then /Taaqa/ must be understood as the possessor in the possessive construction (and, in addition, /pit/ must be deleted). This suggests the following rules:

(24) Hopi Rule (a)

The possessor in a possessive NP construction marked as proximate must be [+coref] with the subject of the main clause.

Hopi Rule (b)

The possessor in a possessive NP construction marked as obviative must be [-coref] with the subject of the main clause.

Again (a) and (b) can be collapsed:

(25)

Hopi Rule 2

The possessor in an [ $\alpha$ prox] possessive NP construction is [ $\alpha$ coref] with the subject of the S.

An extra mechanism was needed to explain the possessive facts. We propose Hopi Rule 2 to account for just those facts.

#### 4.2.3. A Third Hopi Rule

An intriguing possibility at this point is this. Is it possible that Hopi rules exist as well for verb phrases and postpositional phrases, given that we have a Hopi rule for clauses and noun phrases? Apparently so, for consider other cases of necessary coreference and non-coreference, involving first, verb phrases:



(26)

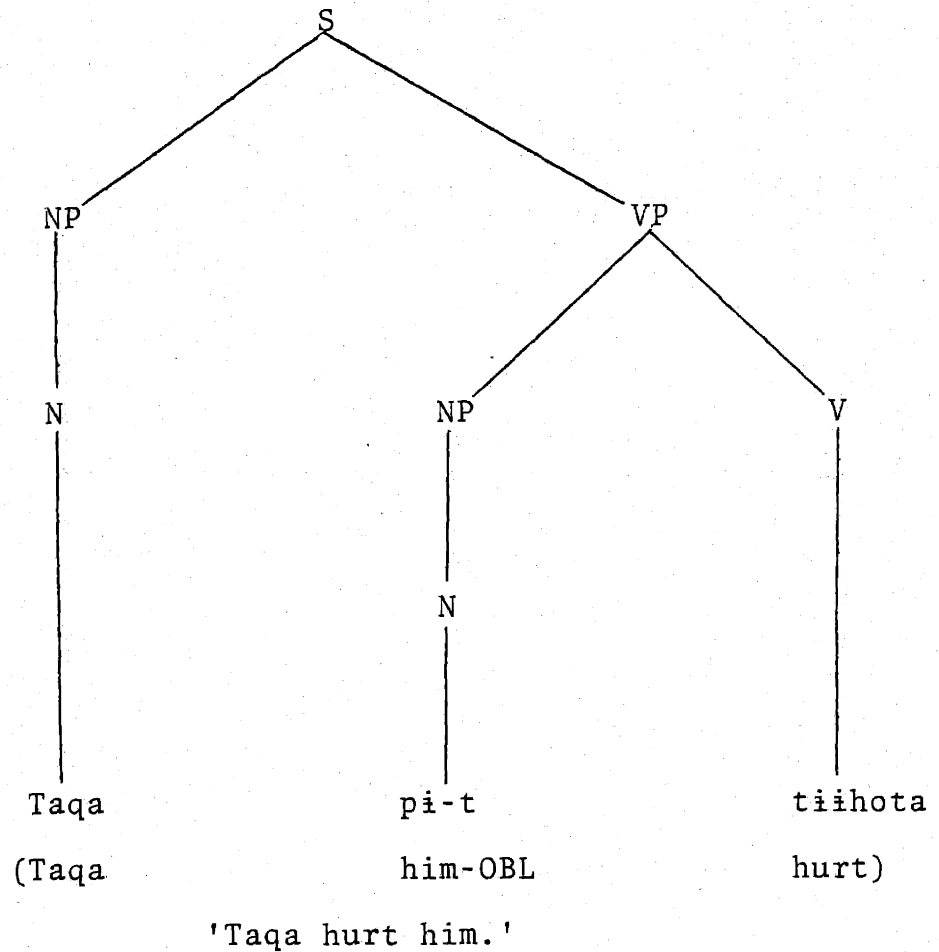

In (26), the subject /Taqa/ and the object /pit/ may not be coreferential. However, there exist cases where coreference must hold between subject and object--i.e. in a reflexive sentence,

- (27) Taqa naa-tihota  
 (Taqa REFL-hurt)  
 'Taqa hurt himself.'

which we will assume has a phrase marker,

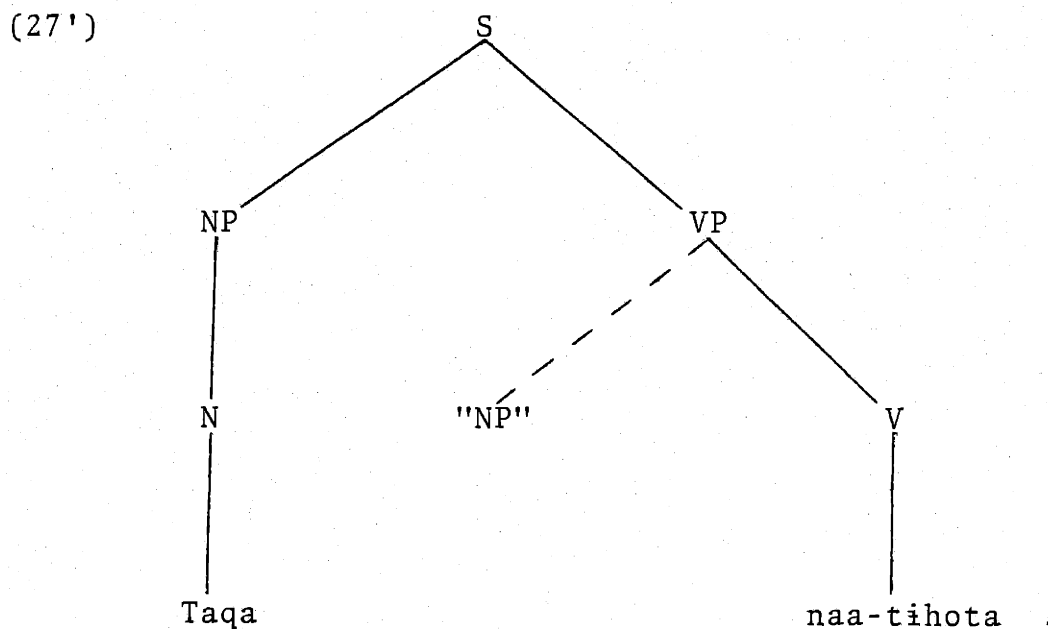

The status of the necessarily empty "NP" will be discussed in a later subsection, at which point we will also deal with the third person proximate possessive construction in which there is no overt noun phrase in complement (i.e. "possessor") position.

In a reflexive sentence, the subject and the "empty" object must be coreferential. If the reflexive verb is regarded as the [+prox] case, and if the non-reflexive is the [-prox] case, then we can postulate:

(28) Hopi Rule 3

The object of an [αprox] VP is [αcoref] with the subject of the sentence.

4.2.4. A Fourth Hopi Rule

We now consider sentences involving the postpositional phrase. Consider sentence (29), given with its phrase marker:

(29)

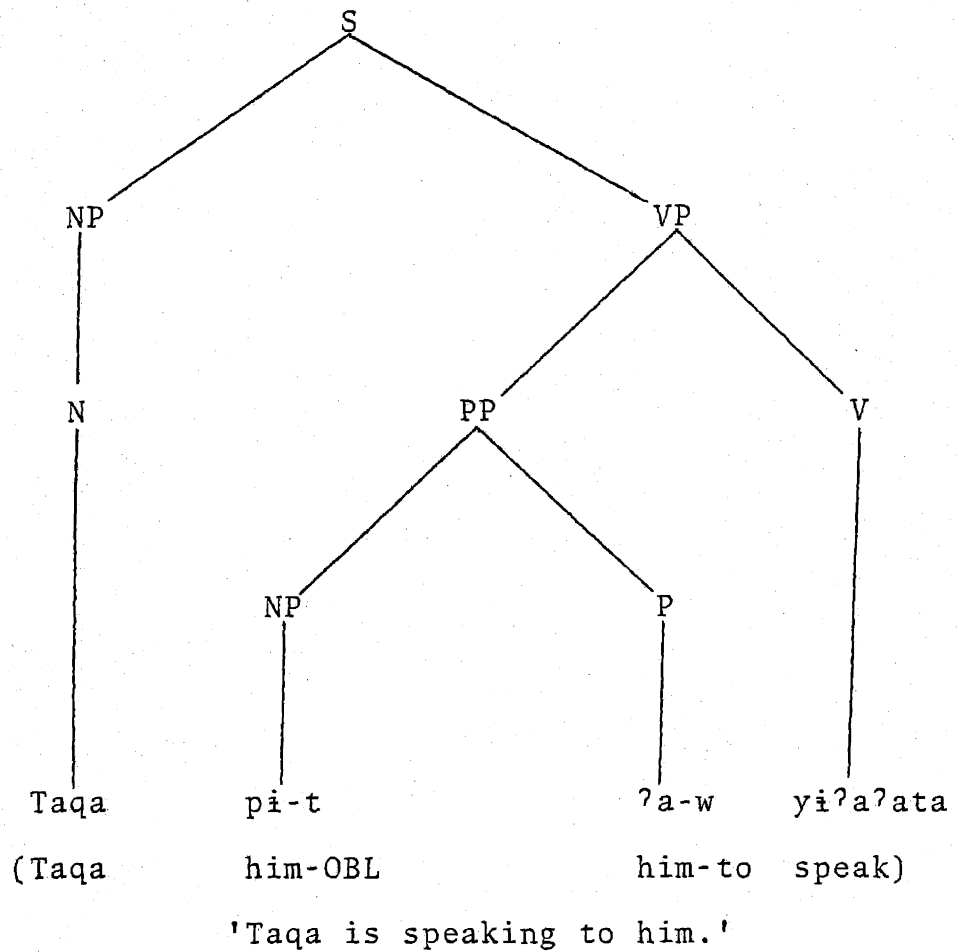

In (29), /Taqa/ and /pit/ must be disjoint in reference.

Now contrast this situation with that represented by

(30):

(30)

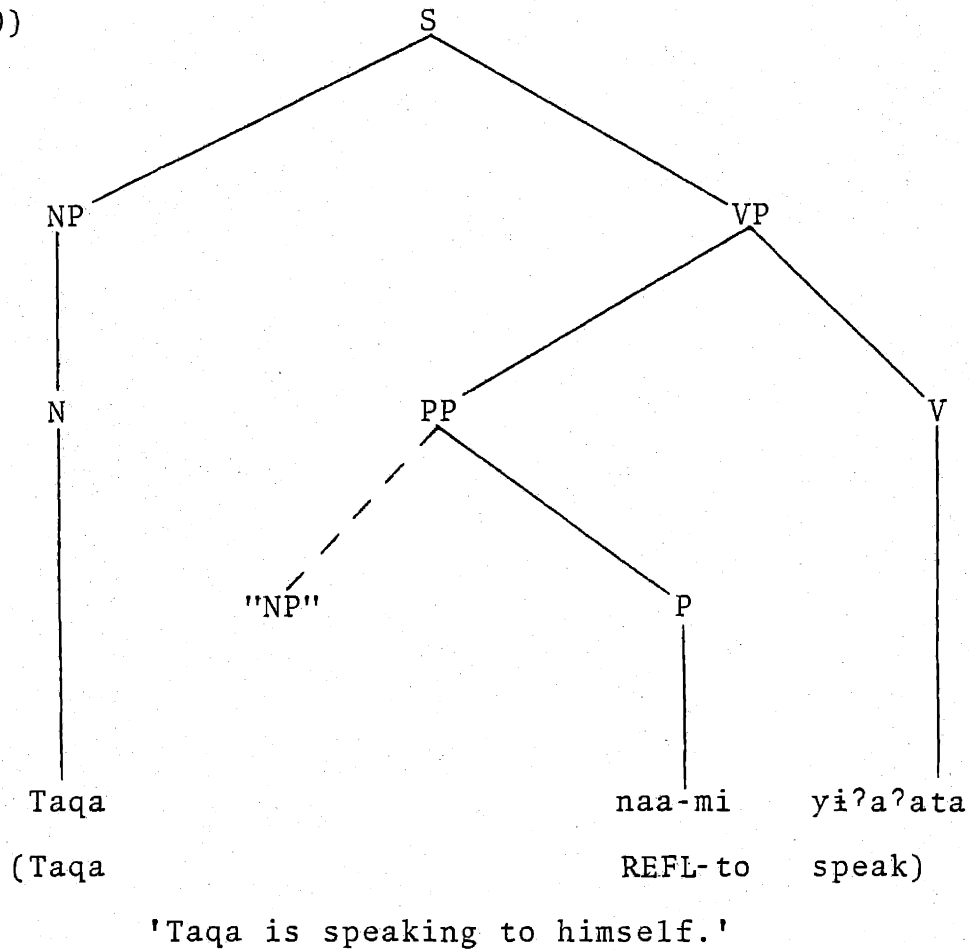

This is an example of a reflexive postposition (cf. section 2.4.0. above). Here, as in the case of the reflexive VP, the subject /Taqa/ and the "empty" object noun phrase must be co-referential. This suggests a final Hopi rule of the following form:

(31)

Hopi Rule 4

The object of an [ $\alpha$ prox] PP is [ $\alpha$ coref] with the subject of the sentence.

4.3.0. Discussion

From the above, it is evident that the principle of obviation does much of the work of the general rule of 'disjoint reference' which functions in so many of the languages of the world. But Hopi is not alone in this respect. There are many languages which mark phrasal categories to indicate that the 'principle argument' of the phrase is to be understood as necessarily either coreferential or else non-coreferential with the subject of the sentence within which the phrase is embedded. In such languages, the disjoint reference rule, which almost certainly also operates in them, reveals its presence only marginally.

Disjoint Reference does, for example, surface in Hopi in the double object construction of verbs like /titiqayna/ 'to teach' (see for example sentence (122) of Chapter 2 above). The indirect object is necessarily either coreferential or non-coreferential with the subject of the sentence, depending upon the obviation indicated in the verb. The direct object, however, is not assigned coreference or disjoint reference by the Hopi Rule. The Disjoint Reference Rule applies in this

case to relate the direct object and the subject as disjoint in reference. Hence, in

- (32) ?i-tana    ?i-pava-y       pi-t    titiqayna  
 (my-father my-brother-OBL it-OBL teach)  
 'My father is teaching it (e.g. Hopi) to my  
 brother.'

- (33) ?i-tana    pi-t    naa-titiqayna  
 (my-father it-OBL REFL-teach)  
 'My father is teaching it to himself.'

/pit/ cannot be coreferential with /?itana/.

Obviation is also known by the term 'switch reference' (cf. Jacobsen, 1967, in which its importance in Hokan languages is discussed), and the so-called 'sentence-medial forms' in many languages of New Guinea are an especially exuberant expression of the principles inherent in obviation.

It seems evident to us that the four 'Hopi Rules' exemplified above are, in fact, a single principle in Hopi grammar. The problem to which we would like to address ourselves now is that of developing a conception of Hopi grammar in

which the obviation principle can actually be expressed as a single phenomenon, rather than four, or possibly even five, separate ones.

It is perhaps quite evident to the reader that the key to generalizing the obviation principle lies in the phrase structure of Hopi. Clearly, what the data seem to indicate is that the principle generalizes to all phrasal categories in Hopi. We must, therefore, attempt to develop a theory of Hopi phrase structure which will be amenable to such a generalization. It is also probably quite evident to the reader that Hopi is a paradigm case for the so-called X-bar theory of phrase structure which is currently being developed (cf. Jackendoff, 1977, both for a historical review of the development of the X-bar theory and for a detailed elaboration of the theory in the context of English syntax). We would like here to advance an elementary theory of the X-bar system for Hopi. Our discussion from this point on is to be considered as highly programmatic--we cannot at this stage of our knowledge pretend to do more than suggest the direction which we feel is promising.

#### 4.3.1. An Elementary X-bar Theory for Hopi

The conception of Hopi phrase structure which we will present here derives, with certain modifications, from the scheme worked out by Hale and Jeanne in the context of a work-



shop on Hopi linguistics conducted at the University of Arizona during the Fall of 1976. It departs in some respects from the system briefly outlined in Hale, Jeanne, and Platero (1977), and it departs to some extent also from recent systems discussed in the literature (e.g. Jackendoff 1977, and Hornstein 1976). In the main, however, it is totally consistent, in so far as we understand it, with the X-bar theory conceived generally--the differences are in detail.

We agree with Hornstein (1976) that the S category is not a projection of the V category--it is separate. However, we do not maintain that it falls outside the X-bar system altogether--thus, we agree both with the tenor of Hornstein's footnote (23) (p. 160), and with the tenor of Jackendoff's integration of S into the X-bar system. Our position is this: S belongs to a special category to be distinguished from the 'parts-of-speech' or 'lexical' categories (N, V, etc.). In our feature system, we will assume that there is a feature [S] whose plus and minus values will distinguish the sentential category from the parts of speech, as follows:

(34)	<table style="border-collapse: collapse; margin: 0 auto;"> <tr> <td style="border-bottom: 1px solid black; padding: 2px 10px;">[+S]</td> <td style="border-bottom: 1px solid black; padding: 2px 10px;">[-S]</td> </tr> <tr> <td style="border-left: 1px solid black; border-right: 1px solid black; padding: 2px 10px;">S</td> <td style="border-left: 1px solid black; border-right: 1px solid black; padding: 2px 10px;">N, V, P</td> </tr> </table>	[+S]	[-S]	S	N, V, P
[+S]	[-S]				
S	N, V, P				

We assume that the sentential category is, like the others, endocentric. This, of course, raises the question of what the 'head' or 'nucleus' of the sentence is--it cannot be the verb, since clearly the verb is the nucleus of the verb phrase. We suggest that the head of the sentence is to be identified with the auxiliary category, which, in Hopi, we maintain is to be identified with the future tense suffix /-ni/, the usitative suffix /-ŋ<sup>w</sup>i/, and the various proximate and obviative conjunctions discussed in 2.7.1. above. In addition, the auxiliary may be phonologically null, as it is when the sentence functions as a main clause in the unmarked tense (non-future, non-usitative).

At some level of representation at least, the auxiliary elements are separate from the verb in Hopi. This is evidenced by such sentence pairs as (35 a-b) below, in the second member of which the final occurrence of the verb /wari/ 'to run (sg.)' has been "gapped", leaving the future tense behind:

- (35) (a) ?im wari-k-q pii? ni? tiwat wari-k-ni.  
 (you run-k-OBV then I also run-k-FUT)  
 'You run and I will also.'

- (b) ?im wari-k-q pii? ni? tiwat-ni.  
 (you run-k-OBV then I also-FUT)  
 'You run and I will also.'

Sentences must be divided into two types--dependent and main. The auxiliaries in dependent clauses not only indicate the tense and aspectual categories just mentioned; they also indicate obviation, by means of the obviative conjunctions. The auxiliary in main clauses, by contrast, indicates the rather limited system of tense and aspect and, in addition, the imperative mood is limited to main clause auxiliaries. We will distinguish main and subordinate clauses in the feature system, assigning [+Dep(endent)] to the dependent subcategory and [-Dep] to the main clause type.

For the parts of speech--nouns, verbs, and postpositions--we will employ the system of features originally suggested by Chomsky in his paper "Remarks on Nominalizations" (1970). There is some evidence that Hopi belongs to the type in which the parts of speech are organized as follows:

(36)

	+N	-N
+V	P	V
-V	N	---

(Chomsky assigned + values to these features in a different way; however, the features themselves--i.e. [N] and [V] are the ones he suggested for the "basic" parts of speech.) In Hopi, evidently, the class commonly called 'adjective' in other languages is not to be distinguished from the verbal part of speech--hence, no A appears in the above chart. We do not know what the feature complex [-V, -N] corresponds to in Hopi. There is, of course, the class of 'particles', which is certainly nonverbal and nonnominal, but we are not sure that they should be integrated into this major part of speech system. Particles may belong, rather, to a parallel 'minor' system of parts of speech. We will not attempt to settle this question here, in any event, since it is not relevant to the issues with which we are primarily concerned.

The evidence for the organization embodied in (36) above is perhaps not overwhelming, but it is based upon the observation that prepositions share certain properties with nouns and verbs, as indicated in (37) below:

- (37) [+N] (i.e. N and P): both categories take prefixal forms of first and second person pronouns (cf. 2.3 and 2.4 above).

- [+V] (i.e. V and P): (1) both categories prefix /naa-/ for the reflexive-reciprocal;  
 (2) both categories permit incorporation of nominal objects, to a limited extent.

It should be pointed out that nouns share with verbs the ability to appear in 'predicate position'--even to the extent of taking the auxiliary, e.g.

- (38) Pam yaw            taaqa-ni.  
       (he quotative man-FUT)  
       'He will, it is said, be a man.'

This cannot be used as an argument for classifying them together, since postpositions also have this property--see 2.4.0. above.

We have no evidence that the 'depth' of hierarchical organization in Hopi phrase structure exceeds the two-bar level--hence, we will assume that the initial expansion is of X' (using, as is now the common practice, 'primes' rather than 'macrons' to indicate the number of bars). In our initial expansion of all categories, we introduce an optional

specifier ( $\text{SPEC}_X$ ), which is filled by various elements (see below), depending upon the category of the head. Accordingly, we have the following initial expansion schema:

$$(39) \quad X'' \rightarrow (\text{SPEC}_X) X'$$

This subsumes the following rules:

$$(40) \text{ (a)} \quad S'' \rightarrow (\text{SPEC}_S) S'$$

$$\text{(b)} \quad V'' \rightarrow (\text{SPEC}_V) V'$$

$$\text{(c)} \quad N'' \rightarrow (\text{SPEC}_N) N'$$

$$\text{(d)} \quad P'' \rightarrow (\text{SPEC}_P) P'$$

One obvious generalization which any theory of Hopi phrase structure must make is that the 'pleonastic' structure is available for all categories (cf. 3.6.0. above). We assume that the initial expansion effects this generalization--i.e. we assume that one of the elements subsumed under the cover-

term  $SPEC_X$  is a noun phrase. Thus, for example, a pleonastic sentence--or topic-comment structure--like (41) below will have the structure (41'), assuming (as we will, but without strong arguments one way or another) that  $SPEC_S$  is an actual node dominating the topic noun phrase:

(41) Mi? tiyo?ya, ni? pi-t tiwi?yta.  
 (that boy, I him-OBL know)  
 'That boy, I know him.'

(41')

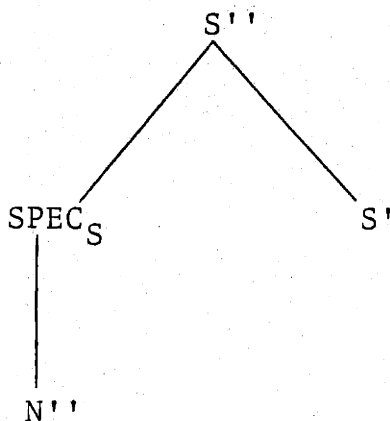

And similarly for all of the phrasal categories.

In addition to the noun phrase of pleonastic structures, various other entities are evidently to be identified with the

various  $SPEC_X$ . For sentences, dependent clauses terminating in the various subordinating conjunctions may be identified with the specifier. Thus, we will assume that a sentence like

- (42) Pam piti-q      ni? pi-t      nopna-ni.  
 (he arrive-OBV I    him-OBL feed-FUT)  
 'When he comes I'll feed him.'

is to be assigned the following structure:

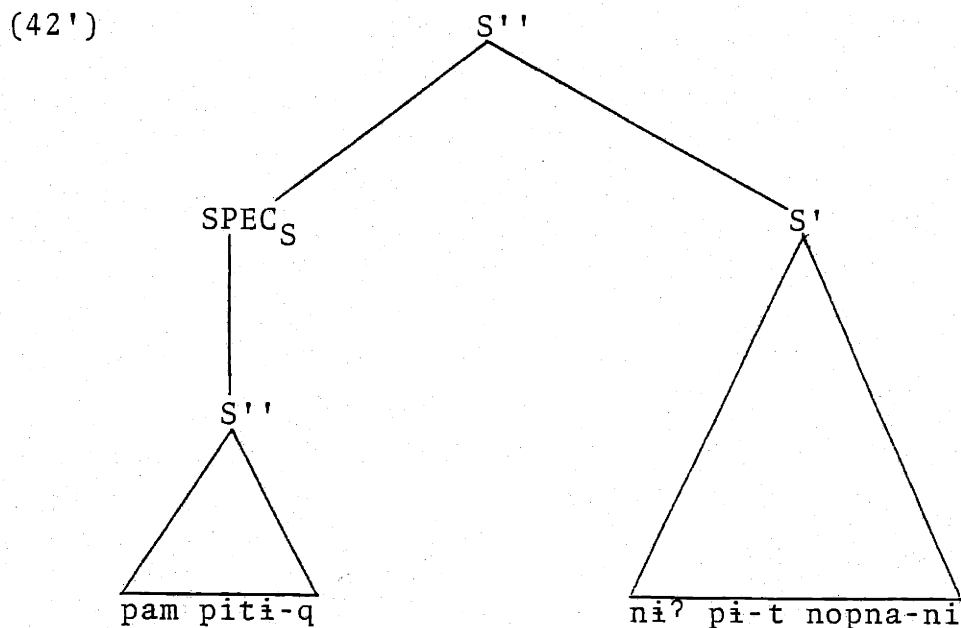



Another entity which might be identified with  $SPEC_S$  is the class of particles associated semantically with the sentence as a whole--for example, the particle which introduces questions, as in (43), given with its upper-level structure:

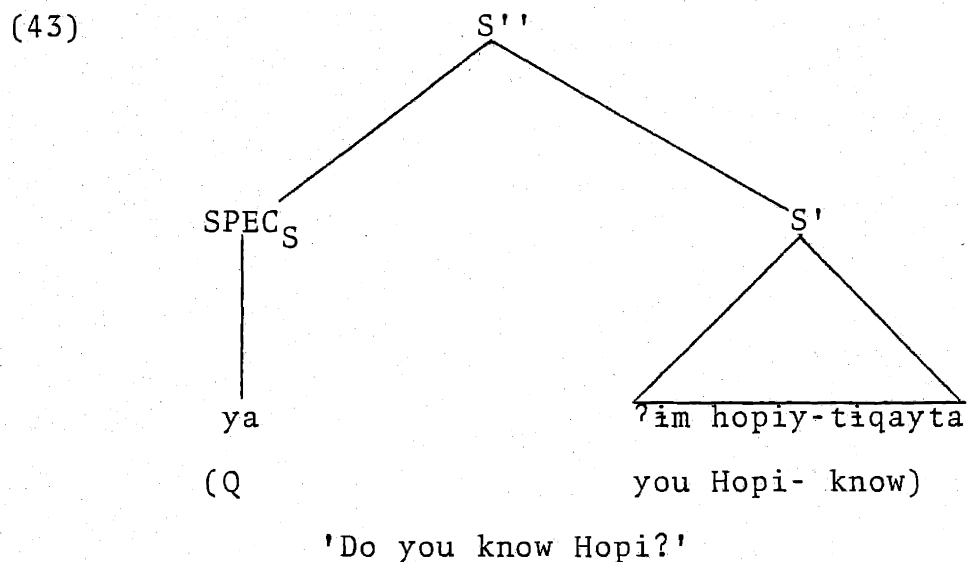

Introducers, like /pii?/ 'then' certainly appear in this position as well. They can cooccur with a dependent clause--as in the somewhat more natural rendition of (42) above, presented in (44) below:

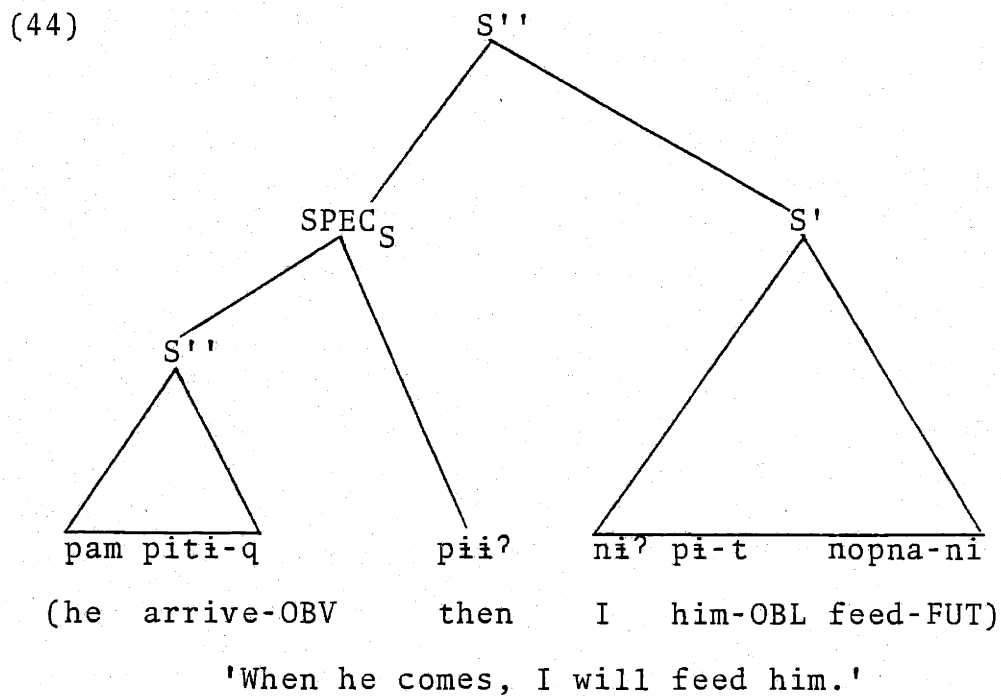

That /pii?/ is a co-constituent with the subordinate clause is indicated by the fact that it moves together with it under extraposition (a possibility for dependent clauses of this type):

(45) Ni? pi-t nopna-ni, pam piti-q pii?.

Verb phrase specifiers include not only the noun phrase in the pleonastic structure (e.g. (58) in 3.5.0. above) but also a number of particles whose semantic scope appears to

range over the verb phrase--as exemplified by /ʔas/ (cf. Voegelin and Voegelin, 1969) in the following:

(46)

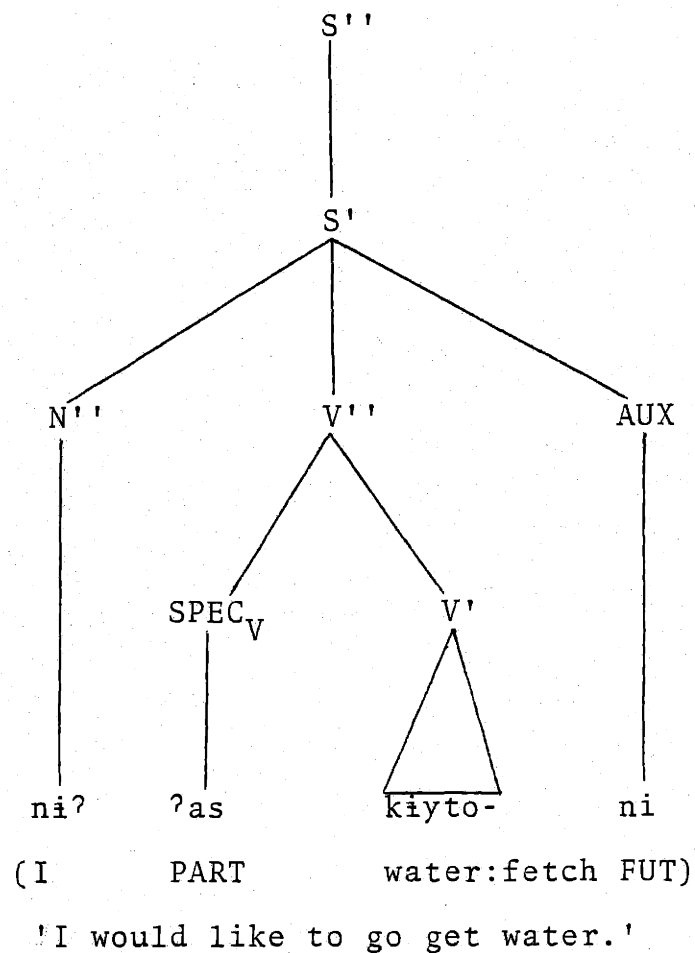

In addition to the noun phrase which can introduce the pleonastic possessive construction, the category  $SPEC_N$  includes the determiners, as in the noun phrase structure (47):

(47)

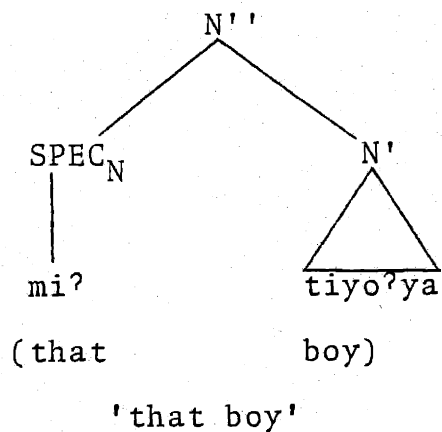

Finally, postpositional phrases, like noun phrases, not only exhibit the pleonastic structure but also have a class of determiner-like elements (referred to in 2.4. as 'adverbials') which probably belong to the SPEC<sub>P</sub> category:

(48)

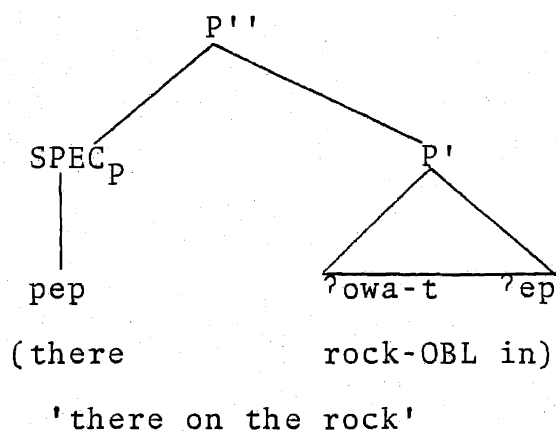

The one-bar level comprises what might reasonably be

called the 'core' of a phrasal category. The expansion of  $X'$  introduces the head of the phrase--that is to say, its nucleus--together with various 'complements' which it selects, if any. We represent this by means of the schema (49):

$$(49) \quad X' \rightarrow \text{COMP } X$$

Here, however, the designation COMP is definitely not to be taken as a node in phrase structure--it stands simply for the range of elements, including sequences of elements, which may precede the head of a phrase. Thus, for the sentence category, the one-bar expansion introduces the head (which we claim is the auxiliary and which we will, following tradition, abbreviate 'AUX', rather than the more consistent, but potentially confusing, 'S') preceded by its 'complements'--i.e. the subject  $N'$  and the predicate. The predicate can be any of the [-S] categories  $V'$ ,  $N'$ , or  $P'$ . This may be expressed as follows:

$$(50) \quad S' \rightarrow N' \begin{array}{c} X' \\ [-S] \end{array} \text{AUX.}$$

This subsumes the following rules:

(51) (a)  $S' \rightarrow N'' V'' AUX$

(b)  $S' \rightarrow N'' N'' AUX$

(c)  $S' \rightarrow N'' P'' AUX.$

The one-bar verb phrase expansion introduces the head-- i.e. V--together with a rich variety of optional complements (optional from the point of view of the phrase structure component, of course, not from the point of view of individual verbs, which may be strictly subcategorized to take obligatory objects, etc.; cf. 2.5.1. above). This is expressed in the following rule, which actually gives only a partial picture of the range of complements which a verb can take:

(52)  $V' \rightarrow (N'') \left( \begin{array}{c} X'' \\ [+N] \end{array} \right) V.$

This subsumes the following:

(53) (a)  $V' \rightarrow (N'') (N'') V$

(b)  $V' \rightarrow (N'') (P'') V.$

And these, in turn, subsume a variety of expansions, depending upon the options which are taken.

For noun phrases, the one-bar expansion introduces the head noun, N, and optionally a possessor noun phrase:

(54)  $N' \rightarrow (N'') N.$

That the possessor in Hopi is a 'complement' and not a 'specifier' is suggested by the fact that a possessor can cooccur with a determiner, and the relative order of the two is as our phrase structure would predict. Thus, consider the noun phrase

(55) mi? po?k<sup>y</sup>aya-t moosa-?at.

(that Po?k<sup>y</sup>aya-OBL cat-OBV)

'that cat of Po?k<sup>y</sup>aya's'

whose structure, we maintain, is as follows:

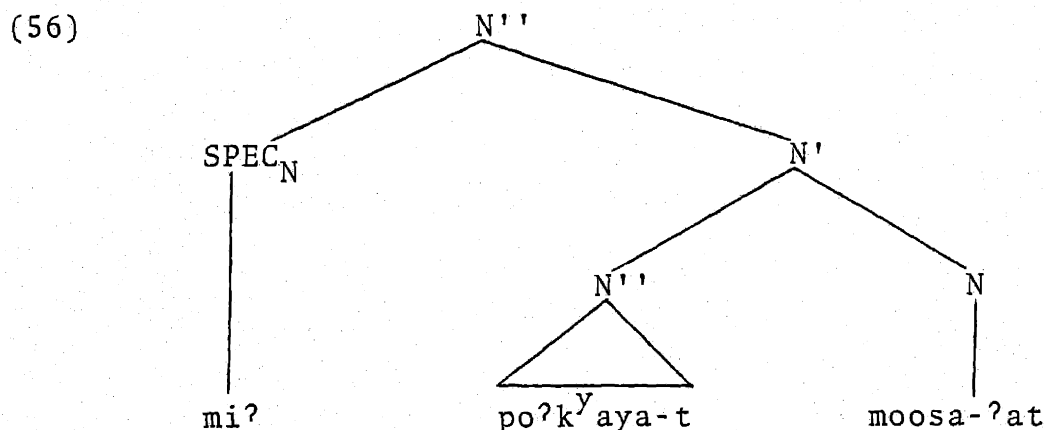

This structure also accounts for the observation that the possessor and the determiner may, as in (56), show disparate case marking--the possessor is necessarily oblique, but the case of the determiner depends, of course, upon the case of the noun phrase as a whole, since case is assigned to determiners by Case Concord, not by NP Case Assignment (see (55) and (56), Chapter 3 above).

In Chapter 3, we suggested that nominalizations in /-qa/--i.e. both relative clauses and 'factive' nominalizations--were also complement-head constructions, and that the element /-qa/ was the head noun, albeit a defective one. We will continue to assume this, and propose a phrase structure rule of the following form:



(57)  $N' \rightarrow S' N.$

So far as we know, /-qa/ is the only noun subcategorized to accept a sentential complement. Notice also that we assume that the sentential complement is a one-bar structure, rather than a two-bar structure, in order to account for the fact (if it is indeed true) that the nominalized sentence cannot have a specifier. Our analysis here may be quite erroneous. At the end of this chapter, we consider an alternative analysis of nominalizations.

The postpositional phrase, at this level, contains the head postposition, P, preceded by its object. We have, therefore, the following rule expanding the one-bar postpositional phrase:

(58)  $P' \rightarrow N'' P.$

#### 4.3.2. A General Statement of the Hopi Rules

Let us suppose that each nuclear element--i.e. each X in our system of Hopi phrase structure--is either marked or unmarked with respect to obviation. Thus, for example, a noun in a possessive construction in which the possessor is third

person is marked for obviation; and the head noun in a relative clause or factive nominalization is likewise marked for obviation; but nouns are otherwise unmarked for obviation. Considering now just the marked nuclear elements, let us suppose further that they are associated with one or the other value for the feature [PROX(imate)]. In the case of the head noun in a possessive construction, the version in which the obviative ending /-(?)ati/ [-(?)at] appears is [-PROX], while the version lacking that ending is [+PROX]. And in relative clauses, if the head is marked with the t-alternant of the oblique ending it is [-Prox], otherwise it is [+PROX]. The situation is similar for the other parts of speech. Thus, intransitive verbs are unmarked for obviation, while transitives are marked--the reflexive-reciprocal is the [+PROX] case, while the plain form of the verb is the [-PROX] case. Postpositions parallel transitive verbs closely, with the reflexive-reciprocal corresponding to the [+PROX] case. Finally, auxiliaries are marked for obviation only if they are [+DEP]--the ending /-qö/ [-q] is the [-PROX] case, while the other subordinating conjunctions are [+PROX].

The principle of obviation is operative, of course, only in cases where the nuclear element of a phrase or clause is marked for obviation. With this background, we can now suggest a single statement of the obviation principle for Hopi, covering the four 'Hopi Rules' formulated earlier:

(59)

The Hopi Rule

The 'principle argument' of an [ $\alpha$ PROX] X' structure is [ $\alpha$ COREF] with the subject of the immediately superordinate S'.

An X' structure is [ $\alpha$ PROX] if its head is [ $\alpha$ PROX]. The subject of a S' structure is the first (i.e. left-most) noun phrase immediately dominated by the S'-node immediately beneath the S''-node--i.e. the encircled N'' in the partial structure below:

(60)

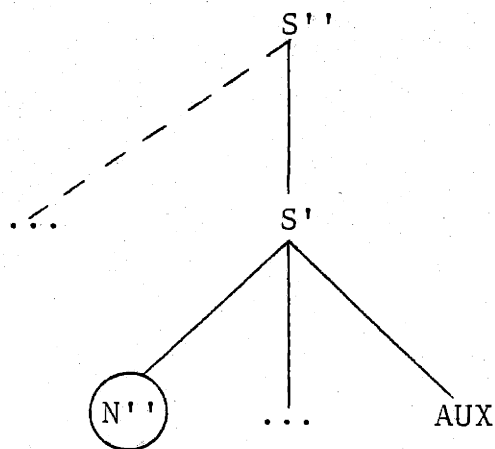

We must stipulate 'first noun phrase' (in linear order), since a predicate noun phrase is also immediately dominated by the S' node. The 'principle argument' of an X' structure is the

left-most noun phrase most immediately dominated by X'. This includes: (i) the subject of a sentence, (ii) the object of a verb phrase, (iii) the possessor in a possessive construction, (iv) the subject of the embedded sentence in a relative clause, and (v) the object of a postpositional phrase. Configurationally, the principle argument corresponds to the encircled N'' in the following particla structure,

(61)

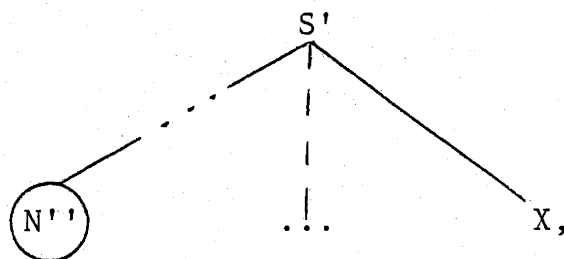

where no N'' node intervenes on the branch connecting the encircled N'' and the dominating X'--and S'-node may intervene, as would be the case in a relative clause.

To illustrate very briefly how the Hopi Rule operates, we will reconsider sentence (9) in the context of the phrase structure system just outlined:

(9)

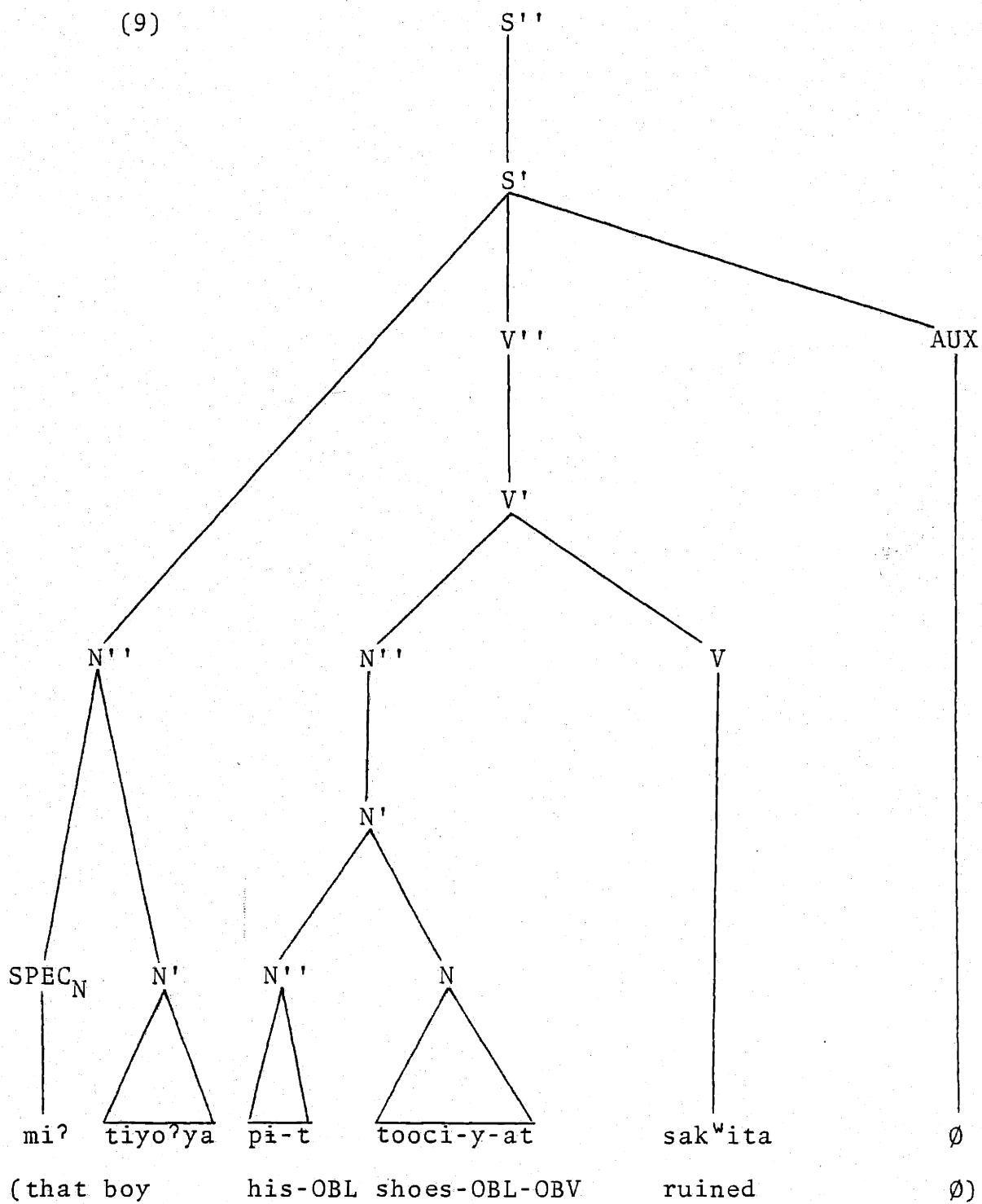

'That boy wrecked his shoes (someone else's).'

This structure is abbreviated in certain respects--i.e. we do not fully develop all of the X' and X' structures--but enough of the structure is developed to illustrate the operation of the Hopi Rule. We are interested, of course, in the possessive construction appearing as the object of the verb /sak<sup>w</sup>ita/ 'to ruin'. The head noun is marked for obviation, and it is marked for the [-PROX] case. Therefore, the pronoun /pi-t/, which constitutes the N' appearing as the principle argument of the possessive construction, is to be marked as [-COREF] with the subject of the sentence, represented by the noun phrase /mi<sup>?</sup> tiyo<sup>?</sup>ya/ 'that boy'. The Hopi Rule actually operates twice in (9), since the transitive verb belongs to the subclass which is marked for obviation. The verb /sak<sup>w</sup>ita/ is in the [-PROX] form, hence its object is necessarily [-COREF] with the subject.

To illustrate the proximate case--i.e. a case of necessary coreference--let us consider the following sentence in which a relative clause appears as an object of the main verb:

- (62) ?ita-na      mi-t      tiyo<sup>?</sup>ya-t pam pi-t  
 (our-father that-OBL boy-OBL he him-OBL  
 tiwi<sup>?</sup>yta-qa-y hoona-ni.  
 know-qa-PROX send:home-FUT)  
 'Our father will send home the boy that he (i.e.  
 our father) knows.'

The structure of this sentence is roughly as follows:

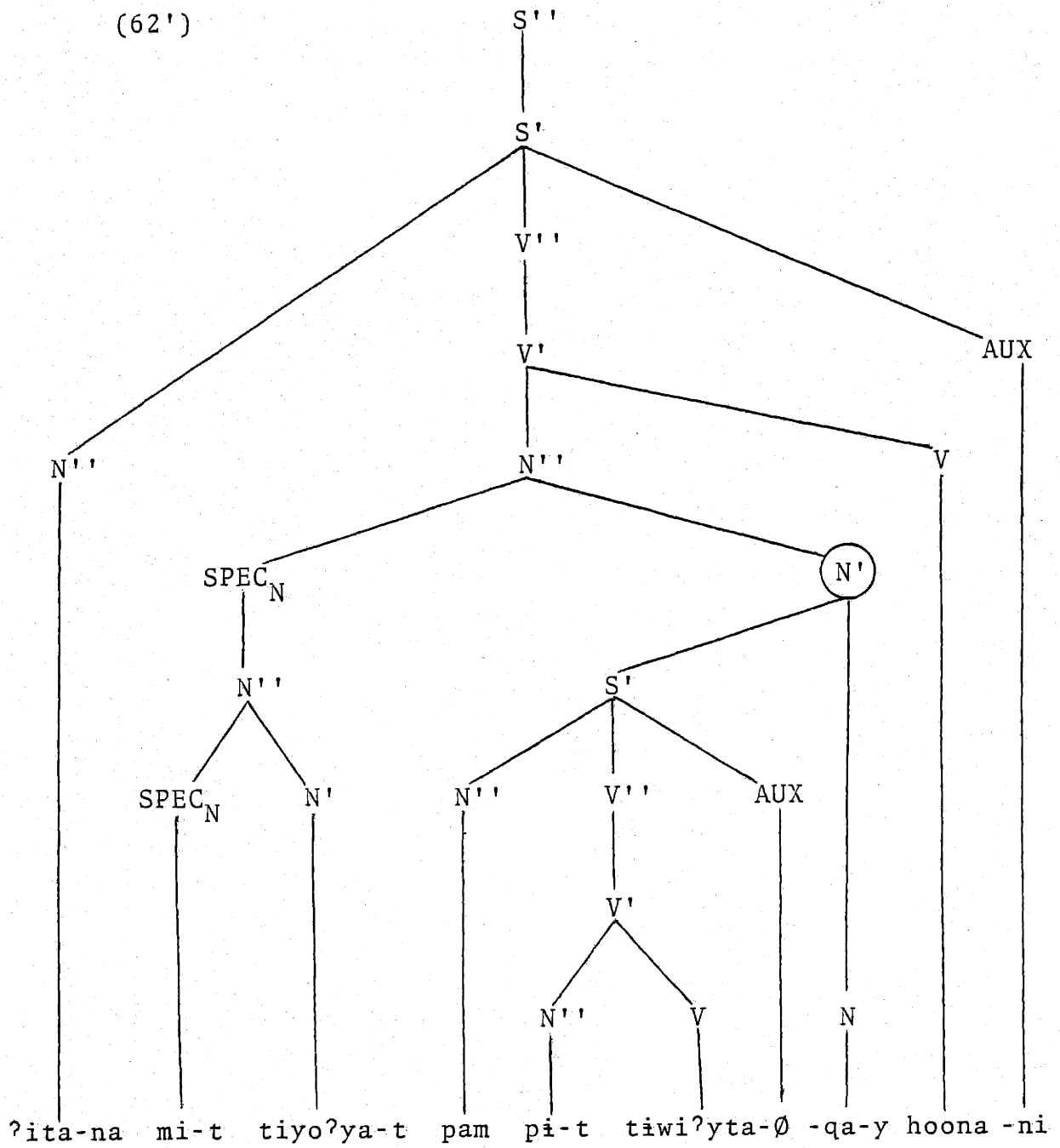

We are concerned here with the structure dominated by the encircled N' node. The head of that structure is marked [+PROX]. Therefore, the principle argument of the N' is necessarily co-referential with the subject of the main clause--i.e. with /ʔita-na/ 'our father'. To locate the principle argument of the relevant N' structure, we trace down the left-branch leading from the encircled N' node until we come to the nearest N'--this is the N' consisting of the pronoun /pam/ 'he'. This pronoun is necessarily coreferential with /ʔitana/ 'our father'. Notice that if the head of the relative clause had been marked with the t-alternant of the oblique ending, rather than with the y-alternant which actually appears in (62), the sentence would receive the obviative reading--that is to say, it would receive the reading according to which /pam/ is not coreferential with /ʔitana/.

It should perhaps be mentioned at this point that the Hopi Rule has a filtering function in the conception of Hopi grammar we are now considering. Notice that there is nothing to prevent us from having a nonsingular pronoun /pima/ 'they', or even a first person pronoun /niʔ/, in subject position in the embedded S' of (62) above. In isolation, such sentences would be perfectly well-formed, and our grammar must generate them:



(63) (a) pima pi-t tiwi?yta.

'They (dual) know him.'

(b) ni? pi-t tiwi?yta.

'I know him.'

However, if these pronouns replaced /pam/ in (62), the result would be ill-formed. The obviation principle would stipulate coreference between the subjects of the embedded and main clauses, but this would violate the very general principle according to which coreferential noun phrases must be mutually consistent in person and number.

Another filtering function of the Hopi Rule has to do with the interpretation of the N'' appearing under SPEC<sub>N</sub> in the pleonastic N'' of (62). There is a general well-formedness condition on pleonastic structures which can be formulated roughly as follows:

- (64) The N'' appearing in SPEC<sub>X</sub> position in a pleonastic X'' structure must be construed with a pronoun somewhere in the immediately following X'.

(We must assume, of course, that a principle or rule which stipulates positive coreference between two noun phrases in a sentence overrides the effect of the otherwise general rule of disjoint reference.) Thus, for example, the left-most N'' in the following pleonastic sentence must be construed either with the subject in S'--i.e. with /pam/--or else with the object in the verb phrase of S'--i.e. with /pit/:

(65) mi? tiyo?ya, pam pi-t tiwi?yta.

(that boy he him-OBL know)

'That boy, he knows him.'

It does not matter which of the two pronouns the topic N'' is construed with. Either interpretation is possible, although for some reason, the preferred construal is with /pam/. Now consider again the pleonastic relative clause structure in (62)--here, the N'' which introduces the structure must be construed with the object in the following S', not with the subject--i.e. it must be understood as coreferential with /pit/, not with /pam/. This is due to the Hopi Rule, in part at least, since that rule stipulates that /pam/, the subject of the embedded S', is necessarily coreferential with the main-clause subject /?itana/--it cannot also be coreferential

with /mit tiyo'yat/, since that would violate another general principle according to which a full noun phrase--as opposed to a pronoun--cannot be coreferential with a noun phrase which both precedes and commands it. This latter principle is, of course, the Non-Coreference Rule of Lasnik (1976). In this case, then, the Hopi Rule filters out an interpretation which would otherwise be available. Notice, incidentally, that /mit tiyo'yat/ 'that boy' could be construed with the subject pronoun /pam/ in (62) if the y-alternant of the oblique ending were replaced by the t-alternant. This follows, since the t-alternant marks the [-PROX] case, stipulating that the subject of the relative clause is disjoint in reference with the main clause subject--in the case of (62), this would free the subject /pam/ for possible, though not necessary, construal with /mit tiyo'yat/.

#### 4.3.3. Missing Noun Phrases

There are, no doubt, major problems with the system we are suggesting here. Since it is meant to be suggestive, rather than fully worked out, we will concern ourselves with just one of the problems that come readily to mind. That is the problem of 'necessarily missing' principle argument noun phrases--that is, the situation in which the principle argument position in a given X' structure is necessarily empty. Moreover, in considering this problem, we will limit our dis-

cussion to cases in which the principle argument is third person, in the hopes that solutions suggested there might be extendable to the non-third person cases.

Let us consider first the obviative and proximate opposition in the possessive construction, illustrated by (66 a-b):

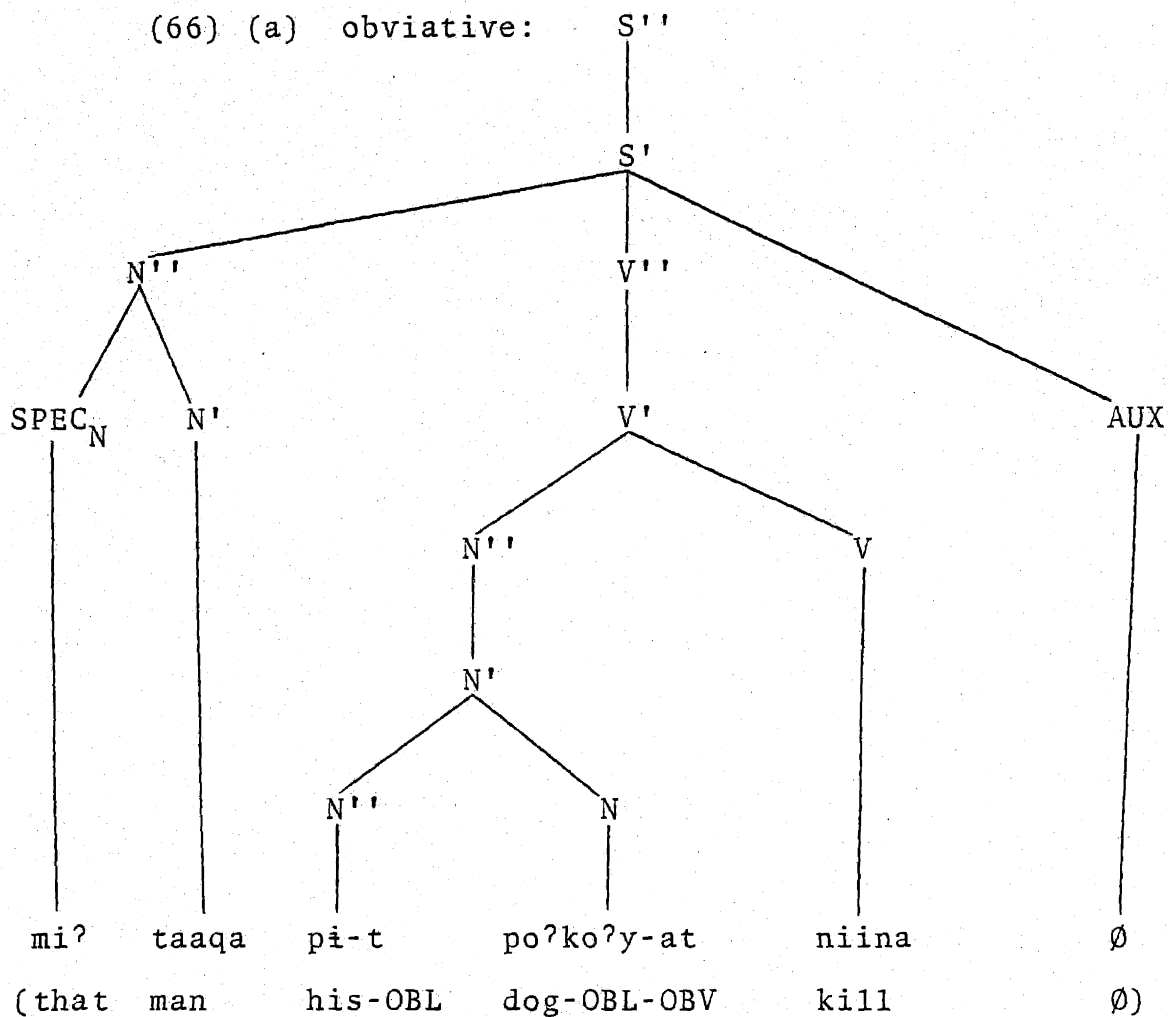

'That man killed his (someone else's) dog.'

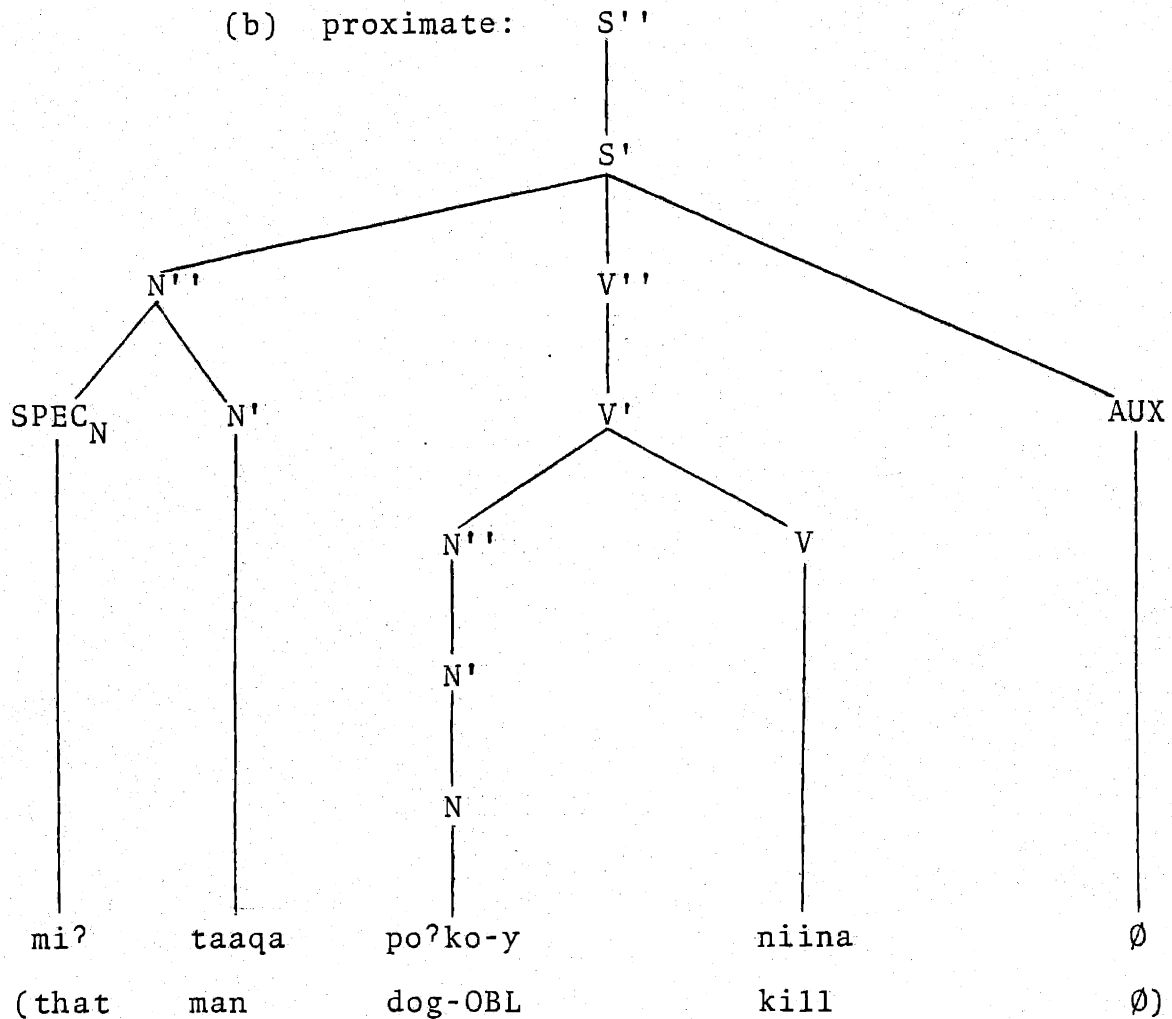

'That man killed his own dog.'

It was pointed out in 2.3. above that, in the proximate case, no overt possessor noun phrase may appear. In the obviative case, an overt possessor noun phrase does appear (though, if it is a pronoun, it may drop optionally). The essential problem is this:

How do we ensure that the possessor position is empty in the proximate case? This problem extends to all [-S] categories, in fact. Thus, in general, in an X' structure marked for obviation, the principle argument must be missing in surface structure in the proximate case. The principle argument of S', however, is exempted from this--thus, the subject of a proximate relative clause may be overtly represented, as it is, for example, in the embedded sentence of (62) above. But, just as in the case of the proximate possessive construction, so also in the proximate (i.e. reflexive-reciprocal) verb phrase and postpositional phrase, the principle argument (i.e. the object) must be missing at surface structure.

This creates a problem for the Hopi Rule as expressed in (59) above, since it will not be able to apply in all of the relevant cases--that is, it will not be able to apply at the surface structure, at least. One possible way out is to assume that there is an interpretive 'prerequisite' to the Hopi Rule. This would consist in a rule which supplies an unexpanded N'' for all X' structures which lack an overt principle argument. The Hopi Rule would then treat this empty N'' just as it would an overt N''--but the unexpanded N'' would not be phonologically realized, thus achieving the desired surface effect. A variety of solutions along this line suggest themselves, but they fail, so far as we can see, to account for the difference in behavior between the sentential category and

the non-sentential categories. We would like to suggest, very briefly, an alternative which has some hope, at least, of reflecting this difference.

Let us entertain the possibility that the necessarily empty principle argument positions are actually filled by an N'' (dominating, say, a pronoun) at deep structure and at the level of syntactic representation at which the Hopi Rule applies. And let us propose further that there is an obligatory deletion rule of the simplest possible sort:

(67)                    N''-Deletion

X	--	N''	--	X	
1		2		3	==>
1		0		3.	

This rule would, of course, be subject to the recoverability condition (Katz and Postal, 1964). But let us imagine that the recoverability condition, in the case of an obligatory rule like (67), is an actual grammatical process which relates a deletion site to an overt N'' in the sentence. Viewed in this way, the recoverability condition is a rule of sentence grammar and is, therefore, subject to the opacity conditions-- specifically the Tensed S Condition (Chomsky, 1973, p. 238).

This scheme would work as follows. In the case of (66b) above, the possessor position would be filled, just as it is in (66a). The Hopi Rule would mark the possessor [+COREF] with the subject--thus making it absolutely recoverable in the sense intended above, assuming as we do that the A-over-A principle does not block the recoverability condition. The deletion rule (67) would, therefore, delete /pit/ from (66b)--giving the correct surface form. The rule could not delete /pit/ from (66a), however, since it is not recoverable in the intended sense. The fact that /pit/ may optionally delete from (66a) is not relevant--that is due to a different process (optional pronoun-drop) which applies to a designated element, i.e. a third person pronoun. In the case of (62), on the other hand, rule (67) would not apply to delete the subject pronoun /pam/ from the embedded S', even though the relative clause is marked [+PROX]. The deletion is blocked because the pronoun is, in a sense, not recoverable--the recoverability condition is itself blocked by the Tensed S Condition. Again, the optional deletion of /pam/ in (62), which is in fact possible, is by a distinct process.

We realize, of course, that there is a degree of perverseness in this analysis. On the one hand, we allow the Hopi Rule to violate the Tensed S Condition--it is possible to understand it as being expressly designed to violate the opacity conditions generally--and, on the other hand, we invoke



the Tensed S Condition to block the application of the recoverability condition in the very same configuration. Still, it is possible that something of this nature is correct, since it does hold out the promise of reflecting the difference between sentential and nonsentential categories with respect to the problem of necessarily missing noun phrases.

#### 4.3.4. Hopi Number Agreement

In 2.1.4. above, we expressed the belief that a general formulation of number agreement in Hopi would be possible with a proper conception of Hopi phrase structure. The idea, roughly, was that elements "in construction with" one another would have to agree in number in order for the construction as a whole to be well-formed. To a very large extent, the notion "in construction with" corresponds to the relationship between the head of an X' category and the principle argument. To be sure, this is not the relationship which holds between a determiner and the head noun, where number agreement is observed (cf. 2.1.0. above), but all other cases of number agreement can, we feel, be viewed as agreement between a head and a principle argument. Thus, a postposition is marked nonsingular in agreement with a nonsingular object noun phrase; certain transitive verbs are marked plural in agreement with a plural object noun phrase; and an obviative possessed noun is, under certain circumstances, marked nonsingular in agreement with a

nonsingular possessor. The single exception to this is, we feel, only apparent.

In our discussion of number marking in verbs, we stated that all verbs are marked in one way or another to agree with their subject in number. This is a problem for the idea that agreement is between the head of an X' structure and the principle argument of the X'. The verb (V) is the head of V', while the subject of a sentence is the principle argument of S', not V'. At least this is so in our conception of Hopi phrase structure. It happens, however, that our conception makes a correct prediction. There is evidence that the subject-number agreement in the verb, although it is intimately bound up with the morphology of the verb word, and in some cases, even the stem of the verb, is fundamentally a property of the auxiliary, not the verb itself. If this were so, then we would expect the auxiliary to reflect the number of the subject when the verb itself is missing, through elipsis. And this is correct, as the following pair (with and without elipsis) shows:

- (68) (a) ?ima yi?ti-k-q      pii? ?itam tiwat  
 (you run(pl)-k-OBV then we      also  
       yi?ti-k-ni  
       run(pl)-k-FUT)  
 'You run and then we will also run.'

- (b) ?ima yi?ti-k-q      pii? ?itam tiwat-ya-ni.  
 (you run(pl)-k-OBV then we      also-pl-FUT)  
 'You run and then we will also.'

This suggests that the plural number, which appears in agreement with a plural subject, is associated with the AUX, since it still surfaces when the verb is elided. Notice incidentally that it is the 'regular' plural ending /-ya/ which shows up in such cases, even where the elided verb, if present, would have marked plural by suppletion (as is the case in (68a), in fact).

The idea that subject-number agreement is a property of the auxiliary is consistent with another otherwise mysterious fact of Hopi. The 'concurvive' dependent proximate auxiliary has two forms--i.e. [-k<sup>y</sup>aŋ], for singular subject, and reduplicated [-k<sup>y</sup>aak<sup>y</sup>aŋ], for plural subject:

- (69) (a) Pam timala?yta-k<sup>y</sup>aŋ, sööwi waynima.  
 (he work-nonpl-PROX just walk(sg))  
 'While he is (supposedly) working, he is just loafing (LIT: walking around).'

- (b) Pima timalaʔyyiŋ-kʷaakʷaŋ, sööwi yakta.  
 (they work-pl-PROX(pl) just walk(pl))  
 'While they are (supposedly) working, they  
 are just walking around.'

This observation is not surprising in a theory which proposes that subject-number agreement, in the abstract representation of sentences, is located in the head constituent of the sentence--i.e. the AUX.

#### 4.3.5. A Reconsideration of Nominalizations

We would like now to suggest a possible solution to a certain problem inherent in our theory of nominalizations. The solution falls out of the X-bar system in a natural way.

The problem is this. Except for the case of nominalizations as we have them now, the notion 'principle argument' can be characterized in extremely simple terms as follows:

(70) Principle Argument

The principle argument of an X' structure is the left-most NP immediately dominated by the X'-node.

This characterization does not suffice to locate the principle

argument in a nominalization (relative clause and other desentential nominal complements). To see this, reconsider the phrase marker (62') above. The NP which we wish to identify as the principle argument of the encircled N' structure is the N'' dominating the pronoun /pam/--i.e. the subject of the embedded sentence. This N'' does not satisfy the definition (70) above because there is a S'-node intervening between it and the N'-node which is the relevant N'-node.

The structure we have assigned to relative clauses--such as that given for sentence (62) above--has forced us to encumber the definition of principle argument by saying "most immediately dominated" rather than simply "immediately dominated". By this locution, we meant to allow the search for a principle argument to proceed from the relevant X' category downwards through as many intervening nodes as necessary until the left-most N'' is located. There is clearly something wrong with this.

The problem we feel is inherent in our analysis of the structure we assign to nominalizations. In particular, our decision to identify the element /-qa/ as a head noun accepting a sentential complement results in an excess of structure. We feel now that there is a natural remedy to this situation within the feature system which we have adopted here.

We must capture the following characteristics of nominalization: they function as noun phrases, yet they have

the internal structure and make-up of sentences--that is to say, they are simultaneously nominals and sentences. This suggests that they should be developed directly in the base as an 'overlap category' sharing the sentential and nominal features. According to this suggestion, nominalizations would be defined by the following feature matrix:

(71)

$$\begin{bmatrix} +S \\ +N \\ -V \end{bmatrix}$$

The element /-qa/ would then simply be the head of this overlap category and would appear as one of the elements in the position occupied by the AUX in a pure sentence. What in the earlier analysis was an embedded sentence would now simply be the one-bar level of this overlap category.

To clarify the above, we now convert structure (62) into the new structure (72) which incorporates our revised conception of nominalization. We use the symbol N/S to represent alphabetically our overlap category.

(72)

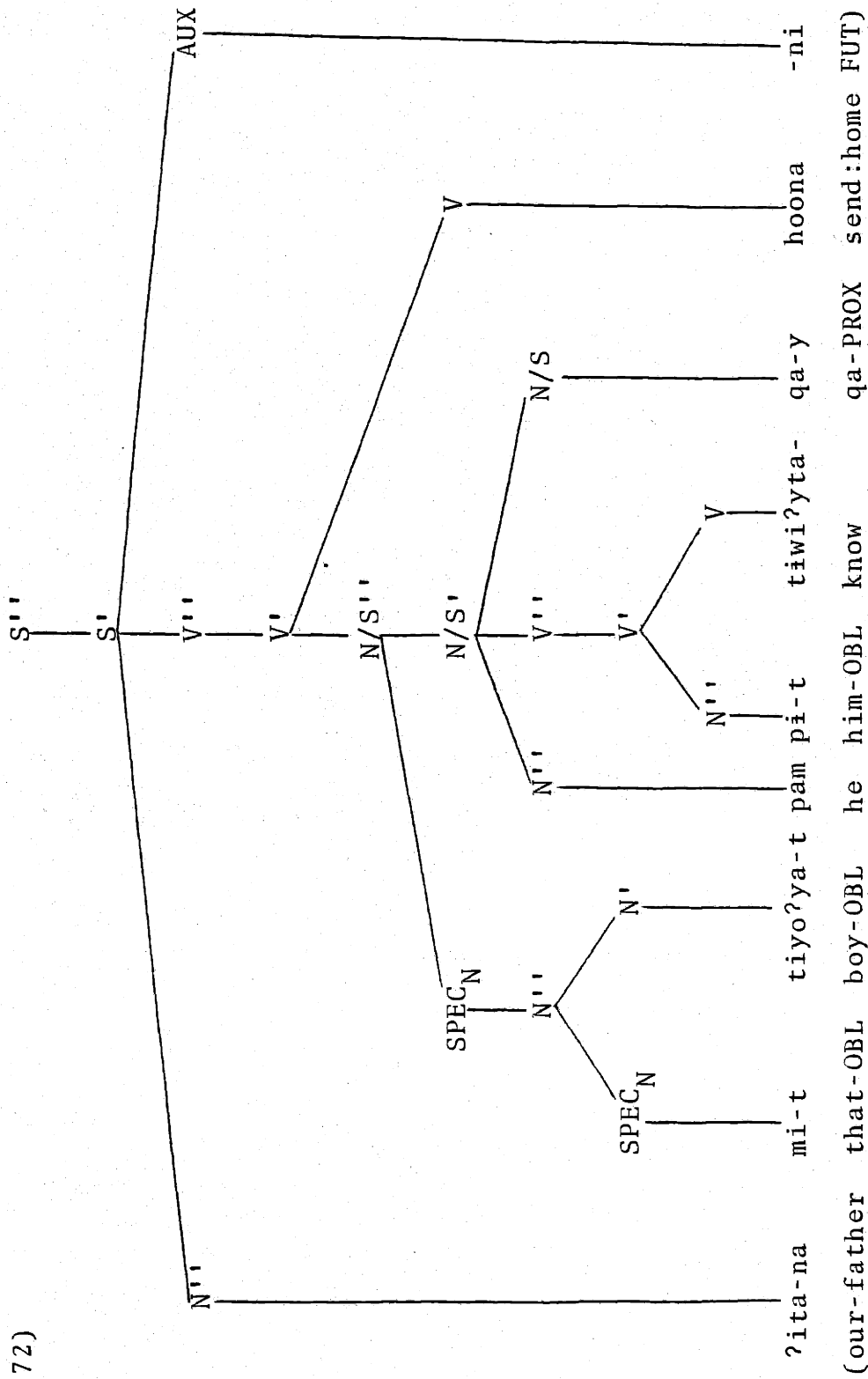

'Our father will send home the boy that he (i.e. our father) knows.'

Notice that the definition (70) will now suffice to identify the N'' dominating /pam/ as the principle argument of the nominalization structure since it is immediately dominated by N/S'-node.

Although we will not pursue this question here in detail, it is quite possible that the feature [ $\pm$ DEP(endent)] is not necessary in Hopi. Notice that there are two sorts of dependent clauses in Hopi, one of which is the nominalization just discussed. The other is the adjoined (adverbial, etc.) clause which, by our analysis, occupies the sentence-specifier position. It is possible that a dependent clause is in reality a sentence which is marked + for the [N]. Thus, a nominalization would be,

(73)

$$\begin{bmatrix} +S \\ +N \\ -V \end{bmatrix}$$

and our old adverbial clause (ADV) could be, so to speak, the "postpositional sentence" having the feature matrix,



(74)

$$\begin{bmatrix} +S \\ +N \\ +V \end{bmatrix}$$

It is no accident, incidentally, that a natural postposition, i.e. /ʔoovi/ 'therefore, because of', can actually appear as the head of a desentential adverbial expression.

This leaves two feature matrices unused, namely,

(75)

$$\begin{bmatrix} +S \\ -N \\ -V \end{bmatrix}$$

and,

(76)

$$\begin{bmatrix} +S \\ -N \\ +V \end{bmatrix}$$

One of these--although we cannot as yet say which--could serve to define the main clause. It is possible that both actually define main clauses, the one marked [+V] defining verbal sen-

tences and the one marked [-V] defining sentences with a noun phrase predicate. Another possibility is that the category (75) should be reserved for the particle expressions which function pragmatically like full statements, as in,

(77) (a) piiyi 'I don't know, search me.'

(b) tima 'Let's go.'

(c) yipa 'Go! Scram!'

...yanhaqam ni? tiwat ?it ?aw wiiwa.

## REFERENCES

- Chomsky, N. (1973) "Conditions on Transformations", in A Festschrift for Morris Halle, S. R. Anderson and P. Kiparsky, eds., Holt, Rinehart, and Winston, New York.
- Chomsky, N. (1970) "Remarks on Nominalizations", in Readings in Transformational Grammar, R. Jacobs and P. Rosenbaum, eds., Blaisdell, Waltham, Mass..
- Grimes, J. (1967) Huichal Syntax, Mouton and Co..
- Hale, K. (1969) "Papago /čim/", IJAL 35, 203-212.
- Hale, K., L. M. Jeanne, and P. Platero. (1977) "Three Cases of Overgeneration", in Formal Syntax, Culicover, et al, eds., Academic Press, New York.
- Halle, M. (1975) "Confessio Grammatici", Language 51, 525-535.
- Hornstein, N. (1977) "S and X' Convention", Linguistic Analysis III, 137-176.
- Jackendoff, R. (1977) "X̄ Syntax: A Study of Phrase Structure", Linguistic Inquiry, Monograph No. 2.
- Jacobsen, W. H. (1967) "Switch-reference in Hokan-Coahuiltecan", in Studies in Southwestern Ethnolinguistics, D. Hymes and W. E. Bittle, eds., Mouton and Co., Paris.
- Kalectaca, M. (1978) Lessons in Hopi, University of Arizona Press, Tucson, Arizona.

- Katz, J. and P. Postal. (1964) An Integrated Theory of Linguistic Description, MIT Press, Cambridge, Mass..
- Keenan, E. and B. Comrie. (1972) "NP Accessibility and Universal Grammar", Linguistic Inquiry VIII, 63-100.
- Kiparsky, P. (1973) "Phonological Representations", in Three Dimensions of Linguistic Theory, O. Fujimura, ed., TEC Company, Tokyo.
- Langacker, R. W. (1970) "The Vowels of Proto Uto-Aztecan", IJAL 36, 169-180.
- Lasnik, H. (1976) "Remarks on Coreference", Linguistic Analysis II, 1-22.
- Masayesva-Jeanne, L. (1974) "The Relative Clause in Hopi", unpublished manuscript, MIT.
- Postal, P. M. (1974) On Raising, MIT Press, Cambridge, Mass..
- Voegelin, C. F. and F. M. (1969) "Hopi /ʔas/", IJAL 35, 192-202.
- Voegelin, C. F. and F. M. (1975) "Hopi /-qa/", IJAL 41, 381-398.
- Voegelin, C. F. and F. M. and K. L. Hale. (1962) Typological and Comparative Grammar of Uto-Aztecan: I (Phonology), Indiana University Publications in Anthropology and Linguistics, Memoir 17, Supplement to IJAL 28.1.
- Whorf, B. L. (1946) "The Hopi Language, Toreva Dialect", in Linguistic Structures of Native America, H. Hoijer, et al, Viking Fund Publications in Anthropology 6, 158-183.