

Design of Debris Cleaner With Compound Auger and Vacuum Pick Up

by

Martin L. Culpepper

Bachelor of Science in, Mechanical Engineering (1995)
Iowa State University

SUBMITTED TO THE DEPARTMENT OF MECHANICAL ENGINEERING IN
PARTIAL FULFILLMENT OF THE REQUIREMENTS FOR THE DEGREE OF

MASTER OF SCIENCE
AT THE
MASSACHUSETTS INSTITUTE OF TECHNOLOGY

FEBRUARY 1997

© 1997 Massachusetts Institute of Technology
All rights reserved

Signature of Author
 Department of Mechanical Engineering
January 17, 1997

Certified by
 Professor Alexander H. Slocum
Thesis Supervisor

Accepted by
Professor Ain A. Sonin
Chairman, Graduate Committee

MASSACHUSETTS INSTITUTE
OF TECHNOLOGY

APR 16 1997

LIBRARIES

Eng

Design of Debris Cleaner With
Compound Auger and Vacuum Pick Up

by

Martin L. Culpepper

Submitted to the Department of Mechanical Engineering
on January 17, 1997 in Partial Fulfillment of the
Requirements for the Degree of Master of Science

ABSTRACT

This paper is a case study of a product market thesis. In a product market thesis, the student designs, models, tests, and markets a product. This type of thesis may be of more benefit than the typical "paper thesis" for students who are interested in starting their own business, learning entrepreneurial skills, design, or manufacturing. The thesis discusses benefits of the product/market thesis as opposed to a traditional thesis. Using the development of a debris cleaner, the thesis walks through the steps to design, model, build, test, patent, and market a product. Particular emphasis is placed on the thought process used in conceptual design. An abundance of figures, discussion of different concepts, and discussion of manufacturing issues are used to demonstrate the process of conceptual design. The construction of a prototype and characteristics of a production model are covered. Also included are chapters with advice on how to write a patent, make brochures, and give presentations. Benefits of the product market/thesis to the author are discussed, as well as recommendations for students interested in marketing an idea.

Thesis Supervisor: Alexander H. Slocum

Title: Professor of Mechanical Engineering

Acknowledgments

I would like to thank my wife for putting up with my long hours of work. She is most precious to me, and I thank her for all her support, love, and patience.

To my parents, Martin and Terry Culpepper, I give my thanks for their love, support, and guidance. Could they have guessed that their rowdy five-year-old "tinkerer" would one day grow up to be an engineer?

I would also like to thank Professor Alexander Slocum for giving me the opportunity to do this thesis. His guidance in this matter and others has had a great impact on my life. In addition, I thank him for his seemingly infinite patience during times of stagnation.

To the GEM foundation, the Timken Company, the Naval Research Labs, and Professor Slocum, I extend my thanks for providing the funding for this project.

Mostly, I would like to thank God, the ultimate designer in the universe, for allowing me to keep my sanity during the hectic and frustrating parts of the last year. As a fellow designer, I look at this world and wonder how frustrated He is with us. Thank God for His patience.

Table of Contents

Chapter 1 Motivation	6
Chapter 2 Author's Background	9
Chapter 3 Project Background	11
3.1 Problem Statement	11
3.2 Background	12
3.3 Objectives	16
Chapter 4 Beginning Stages of Design	17
4.1 Initial Concept.....	17
4.2 Patentability of Original Concept.....	19
4.3 Background Research.....	20
Chapter 5 Component Design	23
5.1 Auger.....	24
5.2 Vacuum System.....	49
5.3 Drive Train.....	63
5.4 Axle and Suspension.....	84
5.5 Hopper.....	101
5.6 Prototype Frame.....	116
5.7 Chipper/Shredder.....	120
Chapter 6 Prototype Build	122
6.1 Auger/Axle Build.....	122
6.2 Vacuum System.....	136
6.3 Power System.....	148
6.4 Hopper.....	161
6.5 Frame.....	175
6.6 Finished Prototype.....	179
6.7 Plant Layout (Rough Cut)	180
Chapter 7 Prototype Evaluation	183
7.1 Parameters of Interest.....	183
7.2 Set up.....	183
7.3 Proof of Concept.....	184

7.4 Finding the Correct Operation Parameters.....	187
7.5 Power Consumption.....	188
7.6 Suggestions For Improvement.....	189
Chapter 8 Patent Application	191
8.1 Patentability of Original Concept.....	191
8.2 Approach to Patent Application.....	191
8.3 Technicalities of Patent Application.....	192
8.4 Patent.....	197
8.5 Recommendations on Patenting of Ideas.....	198
Chapter 9 Marketing	200
9.1 Background.....	200
9.2 First Marketing Strategy.....	201
9.3 Second Marketing Strategy.....	202
9.4 Discussion of Marketing.....	203
9.5 Forms of Marketing For Selling Ideas.....	204
Chapter 10 Project Schedule	208
10.1 Schedule For Research, Concept Generation, and Modeling.....	208
10.2 Prototype Schedule.....	210
10.3 Patent Schedule.....	219
10.4 Marketing Schedule.....	220
10.5 What was learned.....	221
Chapter 11 General Discussion	225
11.1 Project Goals and Objectives.....	225
11.2 Experience Gained.....	227
11.3 Additions to Résumé and Portfolio.....	229
11.4 A Look at the Project/Market Thesis.....	233
Appendix A Marketing and Business	237
Appendix B Patent Material	259
Appendix C Auger	281
Appendix D Vacuum System	285
Appendix E Power and Drive Train	296
Appendix F Axle	302
Appendix G Hopper	314
Appendix H Frame	322

Chapter 1 Motivation

Upon entering MIT, the author's original intent was to graduate with a M.S. in Mechanical Engineering, then start a manufacturing company. Professor Alexander Slocum

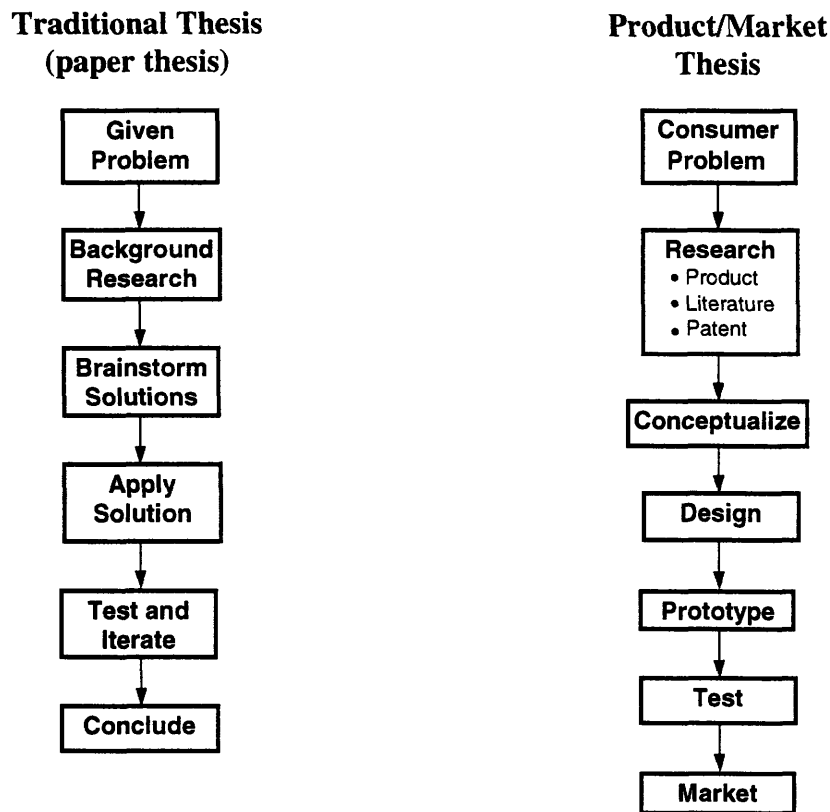

Figure 1-1. 1 Comparison of Traditional and Product/Market Thesis

recommended a product/market as a means to start this process before graduation. In this type of thesis, the student develops an idea or solution via the flow chart shown in Figure 1-1.1. The flow of a traditional thesis is shown for comparison. The main difference between the two is that a product/market addresses a consumer need and attempts to market a solution which fills that need, whereas the traditional thesis is usually research done to find a solution to a problem which is not directly consumer related.

This project was performed in parallel with Professor Slocum's Urban Design Core. Professor Slocum developed the UDC to assist urban youth in taking control of their own economic security by providing them with the tools and knowledge to design, build, and market a product. In essence, enabling people to use their creativity and ability to create wealth for themselves and their communities. This project was done in the same light, however, the author wishes to use this work as a bridge to a broader audience, some day using it as a teaching tool for product design.

Figures 1-1.2 and 1-1.3 show the benefits of the two types of thesis. In a traditional thesis, one learns about a specific area, how to document research, and establishes a reputation.

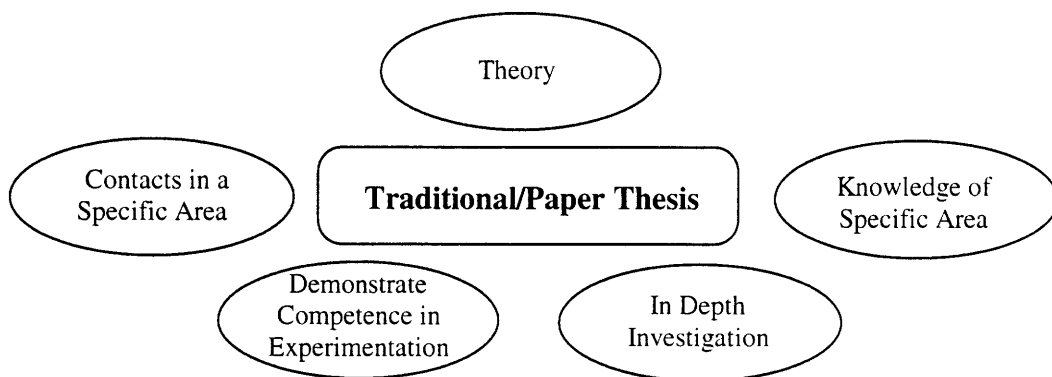

Figure 1-1. 2 Results of Traditional or "Paper Thesis"

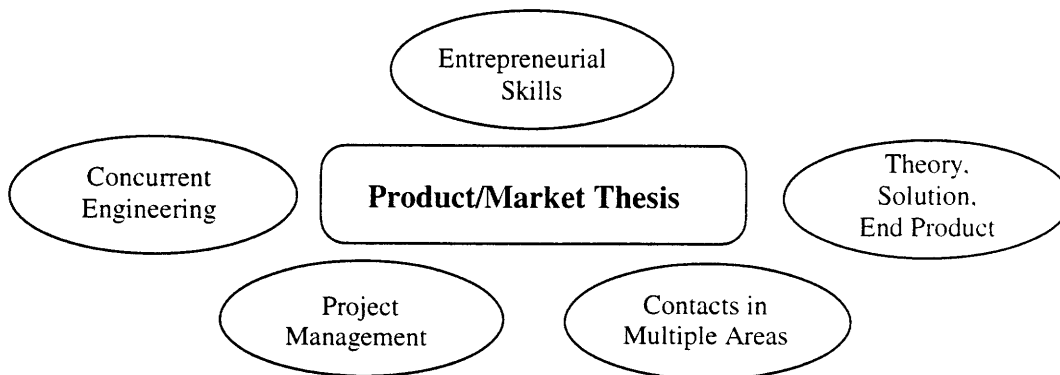

Figure 1-1. 3 Results of Product/Market Thesis

In a product/market thesis, the student learns the process of product design, from the initial concept to marketing of the idea. In addition, project management and entrepreneurial skills are also learned.

The purpose of this paper is not to prove one type of thesis better than the other, but to show that a product/market thesis may be better suited for students with interest in some of the areas below:

- starting a company
- the steps necessary to bring a product to market
- becoming a plant manager
- learning project management skills
- learning more about manufacturing and design

In addition, this paper uses itself as a case study to evaluate the different aspects of a product/market thesis. In doing so, topics are presented in an order which loosely follow the chronological flow of the project. Those covered are listed below:

- author's background
- problem statement and project background
- objectives
- product, literature, and patent research
- concepts and design of machine
- building of prototype and production model
- prototype testing
- patenting process
- marketing
- discussion of project schedule
- evaluation of a product/market thesis

Note to the reader: Chapters 5 (concepts for designs) and 6 (building of the prototype) make up a substantial portion of this thesis. It could be argued that much of the material in these chapters should have been put in the appendices, however, the author thought it better to include the "appendix quality material" to maintain the continuity of the discussion. The author apologizes in advance for the "lengthiness" of these sections.

Chapter 2 Author's Background

Knowledge of an individual's skills is important before judging their decisions or designs. A résumé is provided so that the reader may review the experience upon which the author drew to complete this project. In section 11.3, additions to the résumé and author's portfolio will be presented. While reviewing the following résumé, please note that prior to the project, most of the author's knowledge of machine design was based in course work.

Martin Culpepper

Areas of Interest

- Machine Design
- Product Design
- Internal Combustion Engines

Work experience:

Summer 1995 The Timken Company: Quality Engineering

- Worked in quality engineering troubleshooting tooling failure, designing tooling, testing tooling, and coordinating installation of press monitoring equipment.

Summer 1994 John Deere Waterloo Works: Process Engineering

- Investigated the feasibility of automating a grinding cell.

Summer 1993 John Deere Waterloo Works: Plant and Experimental Engineering

- Worked in plant engineering at the John Deere Waterloo Works.
- Helped set up a test stand for the hydraulic system of a prototype tractor at the John Deere Product Engineering Center.

Summer 1992 John Deere Waterloo Works: Quality Engineering

- Helped design gauges to measure gear profile quality.

Education

- B.S. Mechanical Engineering, Iowa State University, May 1995 (3.7/4.0)
- Candidate for M.S., Massachusetts Institute of Technology

Areas of Study

Iowa State

- Mechanical Systems Design: A project oriented class with two design projects. In the first, designed a helical gear speed reducer. In the second, designed a bicycle suspension system which used Firestone Air Springs™.
- Internal Combustion Engine Design: A project oriented class with emphasis on group design. Project team redesigned components of a four cylinder John Deere diesel engine. Final report included detailed analyses of rod bearing forces, main bearing forces, crank shaft, balancing mechanisms, valve train, cam, and wrist pin.
- Design of Machine Elements I: Fundamentals of Machine Design.
- Design of Machine Elements II: A project oriented class in which multiple projects were approached from a consultant's point of view.

Awards and Honors

- George Washington Carver Scholar, Iowa State
- M.S.A. Outstanding Sophomore Award, 1992, Iowa State
- GEM Fellow, Massachusetts Institute of Technology

Extra Curricular Activities

- Vice-President of Fairchild Floor, Fall Semester, 1993
- President of Fairchild Floor, Spring Semester, 1994
- Community Service, Roosevelt Elementary, Waterloo, IA
- Intramural Volleyball, Basketball, and Football at Iowa State

Personal Interests

Cycling, Weightlifting, Basketball, Fishing, Archery, Automotive Repair

Chapter 3 Project Background

3.1 Problem Statement

Each year, large amounts of money are spent removing leaves, paper, and other debris from residential and commercial property. For owners of these properties, it is desirable to use a debris cleaner which consumes a minimum of power, operates at a low noise level, and is effective in removing debris which is difficult to separate from the surface being cleaned. It is also desired to minimize the amount of down time due to clogging of the cleaner's ductwork and repeated emptying of the collection device.

Suppliers of lawn and garden equipment and individual inventors have designed machines which attempt to perform the task. The machines fit into the following four categories:

- lawn vacuums
- sweepers
- mower deck attachments
- modified snow blowers

These machines do not perform as well as customers would expect. Most are inefficient or cumbersome to operate. The following discussion of the four types of cleaners is provided to better acquaint the reader with prior art.

3.2 Background

3.2.1 Sweepers



Problems With Sweepers

- a. do not shred debris
- b. fill up quickly
- c. fast moving bristles damage lawns

Photograph Courtesy of Ingersoll

Figure 3-2. 1 Sweeper and Common Problems

Debris cleaners which use a brush mechanism are known as sweepers. These machines use one or more rotary brushes rotating at high speed to dislodge pieces of debris from the ground and propel them into a collection hopper. As debris is deposited into the hopper without volume reduction (without shredding), the collection devices on these units must be emptied often. Also, the sweeping members of the brushes must rotate quickly to impart sufficient momentum to propel dislodged debris into the hopper. The fast moving members of these brushes often damage delicate surfaces, such as formal lawns or golf course greens.

3.2.2 Lawn Vacuums

Lawn vacuums use a fan, a system of ductwork, and a nozzle to vacuum pieces of debris, shred, and exhaust them to a collection hopper. Some also use a rotary brush similar to that of a sweeper. A typical lawn vacuum is shown in Figure 3-2.2.



Problems With Lawn Vacuums

- a. high noise levels
- b. excessive fuel consumption
- c. require large, costly engines
- d. tendency to plug up

Photograph Courtesy of Gravelly

Figure 3-2. 2 Lawn Vacuum and Common Problems

The nozzle on lawn vacuums must stretch across the machine's cleaning swath, which is roughly the width of the machine. A high flow rate is needed to maintain a sufficient capture velocity of approximately 3000 fpm (see 5.2.1) at the nozzle entrance. One could decrease the flow rate and maintain the required inlet velocity by decreasing the depth (see Figure 3-2.2) of the nozzle. A nozzle such as this would have a large width to depth ratio, resulting in a larger loss coefficient. The higher losses from entrance effects and increased perimetral area would still

make a large engine necessary. This is undesirable as engines of the required size (approximately 18 hp) use significant amounts of fuel and produce excessive noise.

Also, with the exception of those with a brush, most lawn vacuums have difficulty dislodging wet or embedded debris from a surface such as a formal lawn. Last, the long runs of ductwork in these machines often become clogged. This causes down time as the machine must be shut off to clear the blockage.

3.2.3 Mower Deck Attachments

There are systems which connect to the mower decks of lawn tractors. The mower shreds the pieces of debris, then a fan blows them into a pull-behind hopper via a system of long flexible

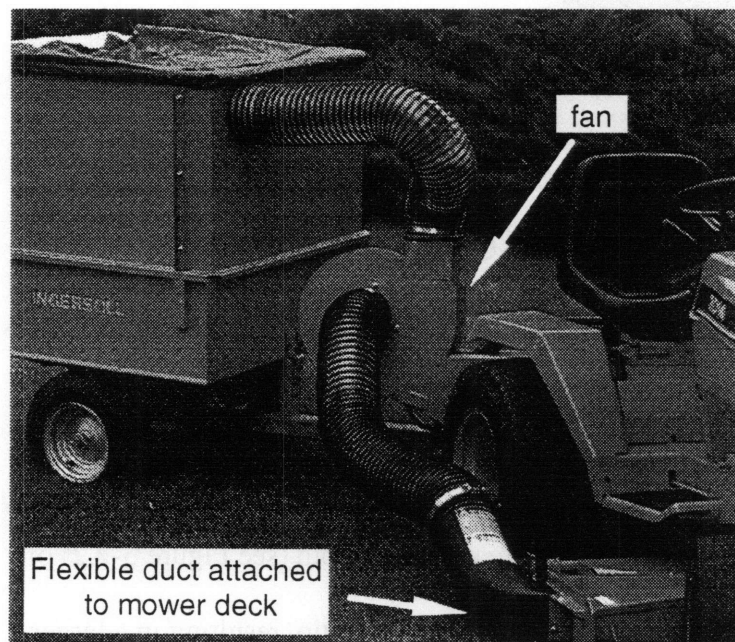

Problems With Mower Assisted Debris Cleaners

- a only for use with lawn tractor and mower deck
- b will not work for all terrain vehicles
- c prone to clogging

Photograph Courtesy of Ingersoll

Figure 3-2. 3 Mower Assisted Debris Cleaners and Common Problems

ductwork. The problem with this type of machine is that one has to own a lawn tractor and mower deck to use it. For many property owners who do not need the extra equipment, or who own vehicles which require pull behind mower decks (such as an ATV), this is not an option. In addition, the long flexible ductwork is prone to clogging.

3.2.4 Modified Snow Blowers

Inventors have tried to modify push snow blowers for use as debris cleaners. In these designs, either some type of rake or brush is attached in front of the blower, or brush like fingers are attached to the auger shaft of the snow blower. Debris is dislodged by the attachments, herded to a central location by the flighting of the auger, then removed by a fan. These machines have not been widely used as they are not capable of cleaning wide paths. Also, uneven terrain can cause the machines to pitch, such that the rigid auger would dig into the ground and damage the surface.

Now that the reader is familiar with available debris cleaners and their shortcomings, design objectives (functional criteria) will be set for the new cleaner.

3.3 Objectives

3.3.1 Design Objectives

To design, build and test a debris cleaner which:

1. will not plug up when cleaning areas with thick debris cover
2. will not plug up when removing wet debris
3. will use less power than conventional lawn vacuums
4. will cost less than similar products on the market
5. will reduce the volume of debris by shredding it as it passes through a fan
6. will not damage delicate surfaces
7. can be pulled behind any vehicle (with a proper hitch)
8. cleans better than similar products

3.3.2 Project Objectives

1. design, test, and make a product
2. patent the new design
3. gain intuitive feel for machine design
4. produce the debris cleaner with the help of an industrial sponsor (original goal was to start a company)
5. provide exposure to the following areas:
 - experimental engineering
 - manufacturing and process engineering
 - entrepreneurial skills
 - patent writing
 - project management

Chapter 4 Beginning Stages of Design

4.1 Initial Concept

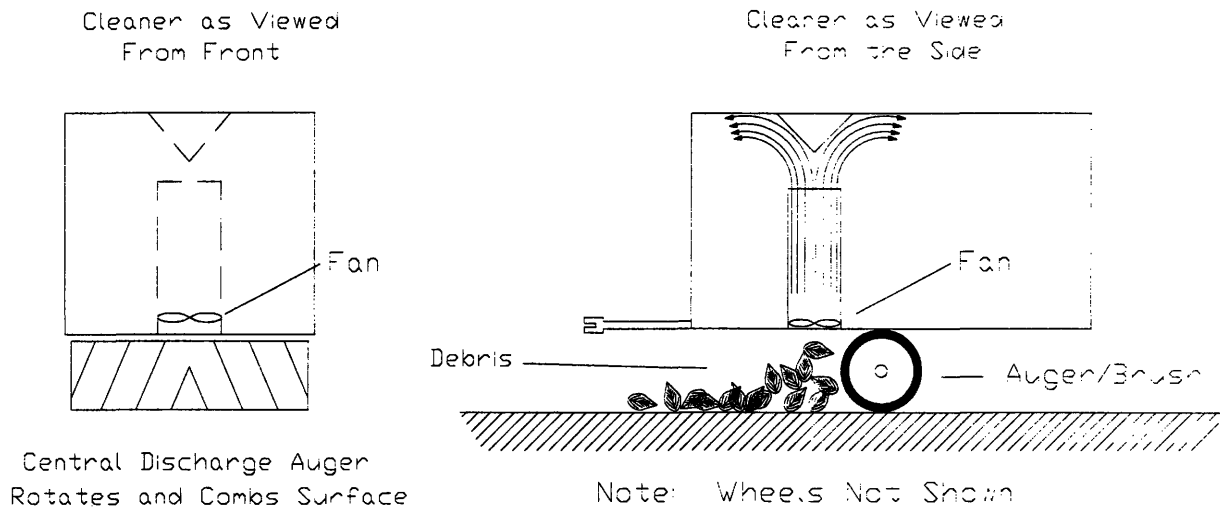

Figure 4-1. 1 Initial Concept Design

The initial concept, shown in Figure 4-1.1, illustrates how the design would work. A vacuum source and rotary element are used to remove debris from the surface. The rotary element is a central discharge auger with compliant finger-like attachments. These attachments comb the grass and deliver debris to the inner core auger. The core auger then conveys the debris to an area below the inlet of a fan..

Since debris is gathered by the compound auger (or spiral brush), the nozzle need not extend across the cleaning width of the machine. This makes possible the use of a smaller nozzle which requires a smaller flow rate (less power) to vacuum debris. The basis for this reasoning is demonstrated with the help of the following discussion.

Assumptions: The following analysis uses air as the conveyed fluid and does not take into account the effect of entrained debris. It also does not include friction or entrance losses and assumes the old and new systems are run at the same pressure. A more accurate analysis will be performed in section 5.2.3.

Assume that the typical lawn vacuum has a cleaning (nozzle) width of 60 inches and a depth of 4.0 inches. The entrance to the nozzle will pass an air flow rate of Q_{OLD} .

$$Q_{OLD} = 60 \times 4.0 \times V_c = 240V_c \quad \text{in}^3/\text{s} \quad \text{Equation 4-1. 1}$$

Where V_c is the average velocity of the incoming air measured in inches per second.

Now assume the nozzle of the new design only needs to be 20 inches long and 4.0 inches deep. For the same capture velocity, the new design would have a flow rate of Q_{NEW} .

$$Q_{NEW} = 20 \times 4 \times V_c = 80V_c \quad \text{in}^3/\text{s} \quad \text{Equation 4-1. 2}$$

With the assumptions above, power is proportional to flow rate. The power needed for the new nozzle as a percentage of the old power would be P_{new}/P_{old} .

$$\frac{P_{NEW}}{P_{OLD}} = \frac{Q_{NEW}}{Q_{OLD}} = \frac{80 \times V_c}{240 \times V_c} = 0.33 \quad \text{Equation 4-1. 3}$$

In this example a machine with the new nozzle would use 33% of the power needed to run the old design. Note that the preceding estimate does not include losses due to entrance effects, friction, and other losses in the components of the ductwork.

Another advantage of this design is that the parts of the auger used to dislodge debris from the ground would be chosen so they could remove wet and heavy debris from areas such as lawns, without causing damage to the surface. Prior machines used hard, thick, rubber fingers to overcome this problem, but still damaged lawns because either the brushes rotated too fast and

shredded the grass, or the fingers were not compliant enough due to their large cross-sectional area or material properties. As the new design uses vacuum pick up, the auger or spiral brush would not be required to rotate so fast as to propel debris into the collection device. Also, the material properties and dimensions of the ground engaging components would be picked so they offer sufficient resistance to dislodge embedded debris, yet remain compliant enough so delicate surfaces would not be damaged.

The last advantage of the new design is the absence of extra ductwork or elbows in the pneumatic system. This is desirable as a pneumatic system with less ductwork offers less friction resistance and fewer areas for clogging to occur.

4.2 Patentability of Original Concept

The new design was similar to that of an upright vacuum cleaner and a two stage snow blower, but was still patentable. The main argument for patentability was that a central discharge auger with compliant attachments was used to dislodge embedded debris and convey it to an area in front of, and midway along the auger. As explained before, this should reduce the amount of power required, thereby allowing for a smaller, less costly engine to be used.

With respect to a vacuum cleaner, the new design was substantially different because it uses a rigid core auger to convey debris, whereas a vacuum cleaner uses a non-conveying drum as the core. With regard to a snow blower, the new design was differentiated by the fact that the debris cleaner was specially made for cleaning delicate surfaces without causing damage.

4.3 Background Research

4.3.1 Product Research and Literature Search

The first step was to determine if the design already existed. This was done by visiting suppliers of lawn and garden equipment (product search), searching brochures from manufacturers of lawn and garden equipment (literature search), and conducting a patent search.

Conducting product and literature searches has the extra benefit of “Lego™ stashing”, or finding novel ideas from other products which could be modified to fit one's own design. It also provides opportunities to make friends with people who use and sell the product on a daily basis. One finds that they become a valuable resource for information and feedback on designs. During this time, the author was also able to examine and test drive some of the available products. This helped in understanding the physics of the product, needs of the customer, and problems with current products.

From this search, the following companies were found to make a debris cleaner of the same general type as the new design.

Table 4-3.1 The Competition and Their Products

	<u>Company</u>	<u>Product</u>	<u>Product Type</u>
1.	Gravely®	Pro Vac®	Lawn Vacuum
2.	Torro®	Rake-O-Vac®	Combination Vacuum / Sweeper
3.	Torro®	Model 44020	Self Propelled Sweeper
4.	Torro®	Model 44040	Self Propelled Sweeper
5.	Torro®	Model 44045	Self Propelled Sweeper
6.	Torro®	Model 44085	Pull Behind Sweeper
7.	Torro®	Model 44089	Pull Behind Sweeper
8.	Torro®	Model 44081	Pull Behind Sweeper
9.	Torro®	Model 44083	Pull Behind Sweeper
10.	Torro®	Model 44010	Pull Behind Sweeper
11.	Trac Vac®	Mower Attachments	Mower Assisted Debris Cleaner
12.	Ingersoll®	Hydra Bagger	Mower Assisted Debris Cleaner
13.	Ingersoll®	Hydra Vac	Mower Assisted Debris Cleaner
14.	Ingersoll®	Sweeper	Pull Behind Sweeper

None of the above machines uses an auger with compliant attachments.

4.3.2 Patent Search

A full patent search can be done in the public libraries of state capitals. One can now perform a limited search through the home page of the United States Patent Office. A patent search involves choosing different categories under which an invention could fall, then searching these topics in the patent database. In this case, categories searched related to snow blowers, vacuum cleaners, augers, brushes, leaf sweepers, street sweepers, debris cleaners, and lawn and garden equipment.

Searching the database on microfilm is a very long and arduous task. It is recommended that the product search be done before the patent search as the prior takes a few hours, whereas the later takes much longer. Following the product search, a limited search should be run using the internet. Only after these two searches have been done, should the full search be started. In the patent for the debris cleaner, 20 hours were spent finding, searching, and reading microfilm.

While doing the patent search, some augers with wiping or elastometric attachments were found. These attachments consisted of strips of rubber or a similar material attached to the end of the auger flighting. In all cases, the machines could not be used as a lawn cleaners because the attachments would not be effective in dislodging embedded debris without damaging the lawn.

As no similar design had been found, the project moved into the concept generation phase. The following chapter discusses the different concepts considered for each component and the selection process used to pick the final designs.

Chapter 5 Component Design

During conceptual design, many different concepts are evaluated. After the best is chosen, it is adapted using favorable components from the other designs. Designing in this way allows one to choose the most desirable components of each design and piece them together like Legos™. Bad components or bad ideas can be discarded before too much effort or money is expended.

Conceptual design usually results in better designs as the designer can mix or match components from the original concepts. Many times, components from different concepts can be put together to form a totally new concept that the designer may not have seen if just thinking about one design.

Conceptual design can also help relieve "designer's block." Many people find it difficult to design because they start with one concept and get stuck halfway through its development. With conceptual design, one skips to another concept when encountering a "block," then returns later, usually with a fresh or different view.

The following sections provide a description of the different concepts for each component and explains how they were sifted through to get the final design. Each section of this chapter generally covers the following steps in conceptual design, but not necessarily in this order:

- concept generation (brainstorming)
- modeling/calculations (when appropriate)
- discussion of manufacturing aspects
- selection of final component

Components and systems covered are:

1. auger
2. vacuum system
3. power systems
4. axle
5. hopper
6. frame
7. chipper/shredder

5.1 Auger

5.1.1 Auger Configuration Concepts

Shown in Figure 5-5.1 are six auger configurations. Arrowed lines show the direction of debris travel and the arrowed arcs show the rotational direction of the augers. Fans are either noted or drawn as propellers.

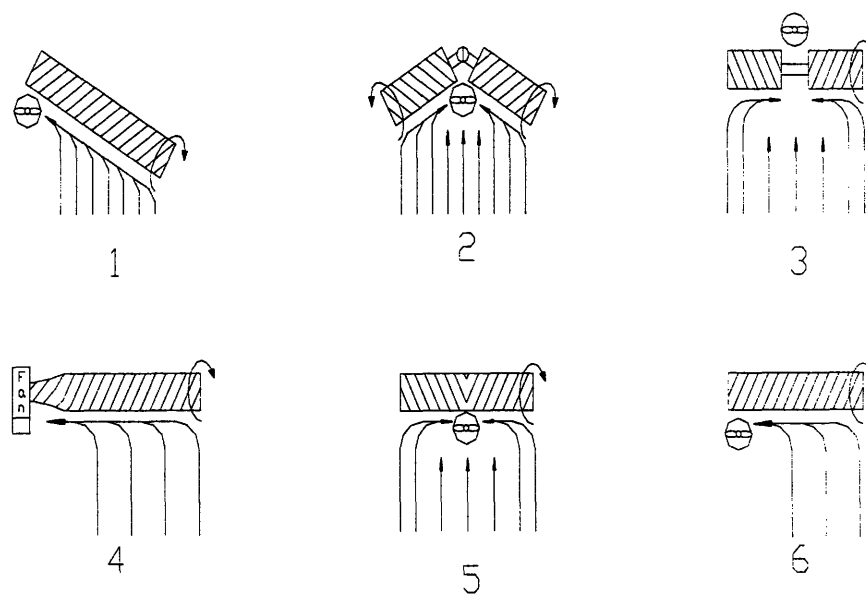

Figure 5-1. 1 Concepts for Possible Auger Configurations

Table 5-1. 1 Selection Matrix For Auger Configuration

1 = good, 3 = fair, 5 = poor

	<u>%</u>	<u>1</u>	<u>2</u>	<u>3</u>	<u>4</u>	<u>5</u>	<u>6</u>
	<u>Weight</u>						
Adjust For Rolling Terrain	20	5	4	2	2	2	2
Debris Work Behind	30	2	2	5	3	3	3
Complexity of Design	15	2	4	3	4	2	2
Cost/Custom Made	15	2	5	2	4	4	2
Confidence in Function	20	2	2	2	4	2	2
Weighted Grade:	-----	2.8	3.4	2.8	3.3	2.5	2.2

The fifth and sixth concepts were chosen for testing of the flighting arrangement.

Following are comments (+/-) which clarify some of the assigned grades.

Design 1

- Adjust for rolling terrain- may be difficult to make angled brush follow rolling terrain

+ Can debris work behind- angled design should make this harder

Design 2

- Adjust for rolling terrain- may be difficult to make angled brushes follow rolling terrain

+ Can debris work behind- angled design should make this harder

- Complexity of design- jointed middle and drive of auger may make complex

- Cost/custom made - would have to make joint design, may be costly

Design 3

- Can debris work behind- wet or embedded debris in middle of machine may not be removed by fan

Design 4

- Complexity of design- junction of tapering flight(s) to fan may pose problems

- Cost/custom made- tapering flights must be custom made

- Confidence in function- tapering flights may obstruct air flow into the fan

Design 5

- Cost/custom made- central discharge augers must be custom made

Design 6, did well for all criteria

5.1.2 Auger Modeling and Testing of Auger Concepts

5.1.2.1 Test Setup

Testing was done to obtain an initial estimate of the best auger configuration to be used in the Alpha prototype. Different pitch to diameter ratios were tried first. Then using the best ratio, different flighting configurations were tested. The test was intended to be qualitative and provide intuition as to the best pitch to diameter ratio for transporting debris. A more rigorous test could have been run, but a quick estimate was needed for the prototype.

The augers were made by wrapping paper strips around an empty pen body, then taping

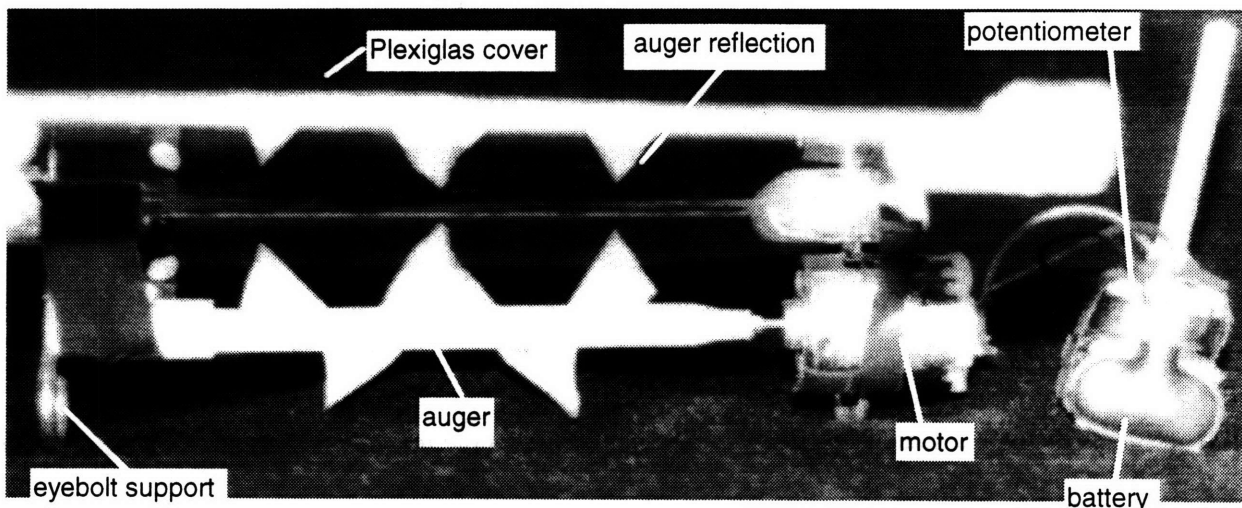

Figure 5-1. 2 Frontal View of Auger Test Stand

the paper into place. The equipment used to test the augers is shown in Figures 5-1.2 and 5-1.3. Two eyebolts at the rear of the frame support a Plexiglas cover. Plexiglas was used so the effect of the augers on the test pieces of debris could easily be seen. Two fixtures (tooth paste tube ends) attached to the underside of the Plexiglas support the auger. A mount (paper clip) for an

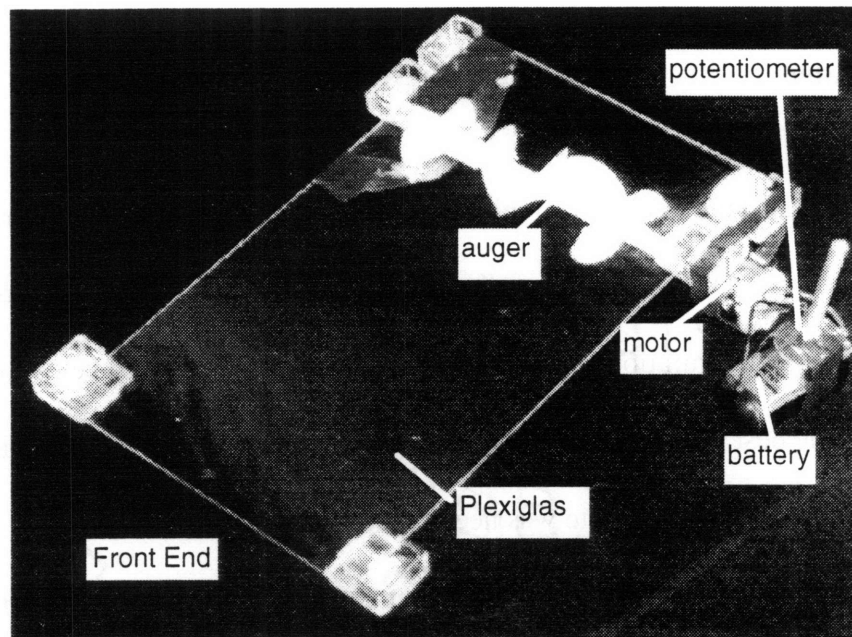

Figure 5-1. 3 Top View of Auger Test Stand

electric motor was attached to the underside of the Plexiglas such that the motor could slide in and out of the clip easily during auger change over. The auger shaft (empty pen body) was attached directly to the end of the motor shaft. The height of the auger axis was controlled by raising and lowering the front of the test stand. Power was supplied by a nine volt battery and was metered using a potentiometer.

As this was a scaled test, it was important to keep the test debris and test augers in similar proportion to their real world counterparts. In other words, running a test with one inch diameter test augers and five inch long strips of paper (test debris) would not provide useful results. The prototype was to have approximately a sixteen inch diameter auger (with attachments). A typical piece of debris, a leaf, was assumed to have a diameter of 2.75 inches. Test leaves were made from left over paper rounds (~ 0.25 inches diameter) from a three ring paper punch. The pieces of paper were bent slightly to imitate the three dimensional shape of a real piece of debris. To maintain roughly the 6 to 1 ratio of a real auger diameter to real leaf diameter, the test augers

were made 1.5 inches in diameter. Also, depending upon the test, the auger speed was approximately between 120 to 180 revolutions per minute.

5.1.2.2 First Auger Test

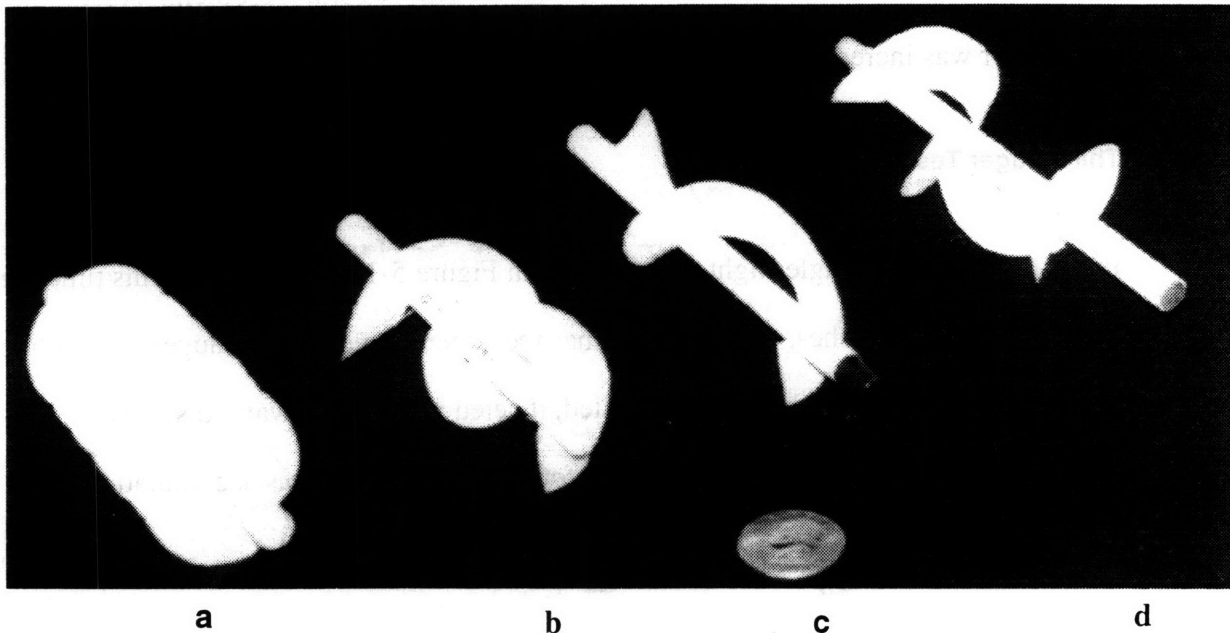

Figure 5-1.4 Model Augers

The first auger, shown in Figure 5-1.4a was a single flight auger with a pitch of 0.50 inches. When tested, the auger did not perform well. Debris accumulated near the end of the auger toward which the debris were being transported. When enough pieces of debris had built up, they worked behind the auger. This was undesirable as a piece of debris which has worked behind the auger must be passed over again to be picked up.

The speed of the auger was changed to increase the transfer rate. When this was done, the auger propelled or "flicked" the debris forward instead of conveying it sideways. This design was discarded and another auger was tested.

5.1.2.3 Second Auger Test

The second test auger was a single flight auger as shown in Figure 5-1.4b. This auger was a standard pitch auger, meaning that its pitch was equal to its diameter. The second auger transported debris better than the first, however, accumulation was still a problem. Again, the speed of the auger was increased, but as before, this attempt failed in the same way.

5.1.2.4 Third Auger Test

In the third test, the single flight auger shown in Figure 5-1.4c, was used. This time the pitch of the auger was 2.5 inches, or about 1.7 times the auger diameter. The auger looked like a paddle wheel from an old steam boat. When tested, it acted in the same way. Instead of conveying the debris to the side, it "flicked" them forward. The result was accumulation of debris across the entire auger.

5.1.2.5 Fourth Auger Test

The most promising results had come from the standard auger. The fourth auger, shown in Figure 5-1.4d, was a standard, central discharge auger (right hand thread on one half and left hand thread on the other). This auger performed much better than the previous augers. The benefit of the central discharge design was that material was moved from the outside of the auger to the center, as opposed to being moved from end to end. In this arrangement, the average distance pieces of debris had to travel before collection was shorter, so they could be dislodged and removed from in front of the auger before accumulation occurred. Since this design worked well, it was used in the prototype auger design.

5.1.3 Methods of Auger Manufacture

Three different methods for making the augers were considered. They were the brush and drum type, belt and drum type, and the compound auger.

5.1.3.1 Brush and Drum Auger Type

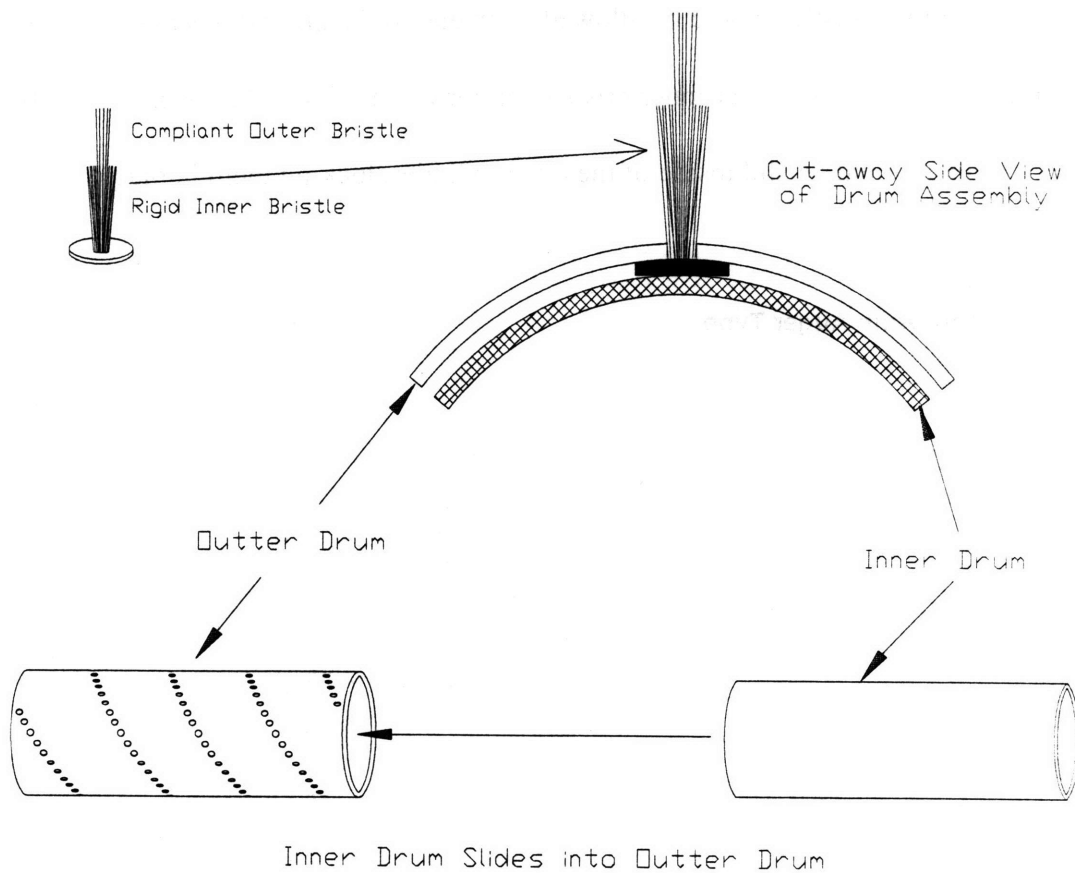

Figure 5-1. 5 Brush and Drum Auger

The outer cylinder would have holes drilled in a spiral fashion around its perimeter. Compliant bristles, brushes, or rubber fingers are slid into the holes as shown. To be effective, an inner region of dense, stiff bristles (or rubber fingers) would be supplemented by an outer

region of less populous, more compliant bristles (or rubber fingers). The reason for the two different types of bristles was that the short, stiff bristles by themselves would be able to convey material like an auger, but because of their stiffness, would cause damage to lawns. At the other extreme, long compliant bristles could dislodge pieces of debris without causing damage to a lawn, but would not be stiff enough to convey them. The benefits of both can be realized if the dense, rigid bristles are kept close to the brush axis where they will not contact the ground. The outer, less populous bristles would be allowed to extend to the ground where they could dislodge debris and deliver it to the stiffer inner bristles for conveying. To hold the bristles or fingers in place, a cylinder would be slid inside of the outer cylinder, locking them in place.

5.1.3.2 Belt and Drum Auger Type

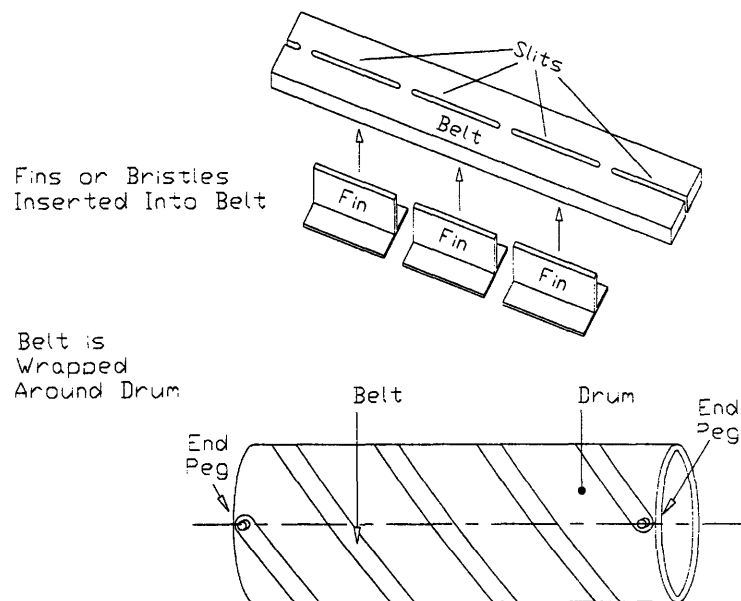

Figure 5-1. 6 Belt and Drum Auger

The belt and drum type, shown in Figure 5-1.6, would be made by inserting rubber fins or brushes (configured as in the last design) into slits in a belt, which would be wrapped around a

drum. The appeal of this design was that the pitch of the auger could be changed by disconnecting the belt from the end pegs, stretching (or adding additional belt), and rewinding to a different pitch. This would allow the user to vary the pitch of the auger for different situations. It would also be simple to make as it involves only welding of the end pegs to the drum and cutting or molding the slits in the belt.

5.1.3.3 Compound Auger

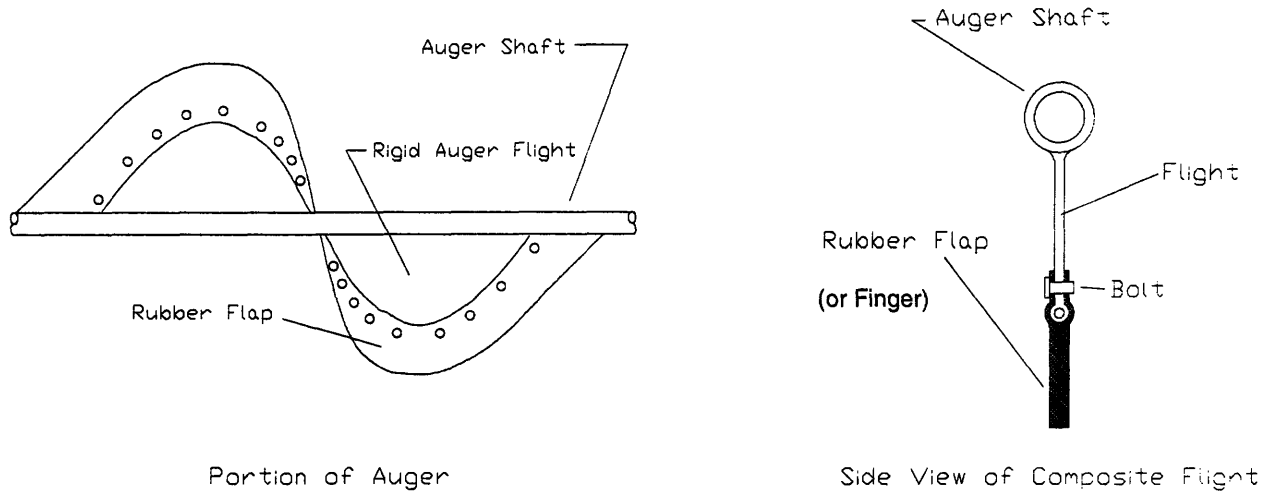

Figure 5-1.7 Compound Auger

The auger shown in Figure 5-1.7 consists of a rigid core auger with attachments connected to the edge of the flighting. Figure 5-1.7 shows a rubber strip, but the attached member(s) could consist of compliant bristles or rubber fingers. Eventually the compound auger design was chosen for use in the Alpha prototype. The reasoning for the choice follows.

5.1.4 Final Auger Design

A selection matrix was used in which each concept was given a grade for several criteria. Each criteria was weighted as to its importance to the overall design. Grades and assigned weights can be seen in Table 5-1.2. Explanations for some of the grades follows the table.

Table 5-1. 2 Selection Matrix For Auger Design				
1 = good, 3 = fair, 5 = poor				
	<u>% Weight</u>	<u>Brush and Drum</u>	<u>Belt and Drum</u>	<u>Compound</u>
Ease of Assembly	5	4	2.5	4
Machining/Labor Cost	10	4	1.5	4
Ease of Maintenance	5	5	1.5	4
Confidence in Functionality	35	2	4	1.5
Material Cost	15	2	1.5	4
*Conveying Ability	30	3.5	3.5	1.5
Weighted Grade:	-----	2.9	3.0	2.4

The compound auger received the best score and will be used in the prototype. Below are comments which clarify some of the assigned grades.

- Brush and Drum** -
- machining, all bristle holes must be drilled
 - ease of assembly, positioning bristles, then inner drum will be difficult
 - maintenance, requires disassembly to replace bristles/fingers

Belt and Drum - ease of assembly, rewinding the belt may be difficult as the belt must be stretched or have pieces added to the belt
+ machining, very little machining needed
+ ease of maintenance, easy to change worn out attachments
+ only one drum was needed
- confidence in functionality, it was not clear if the belt would "lift off" or slide around on the drum when the fins engaged debris

Compound Auger - machining, requires machining of holes through steel flight and welding
- material cost, flighting was costly

*Conveying ability was a main factor in choosing the final design of the auger. The draw back to the belt and drum, and brush and drum designs was that a portion of space within the area of influence of the auger (the drum) takes up "conveying space." The compound auger works differently. Like the others, it has a compliant component which engages the ground and dislodges debris, however, it uses the core (the rigid auger) to help convey the debris. With the core aiding in transport instead of taking up space, debris can be dislodged and removed from in front of the auger more efficiently.

5.1.5 Compliant Attachments

5.1.5.1 Attachment Concepts

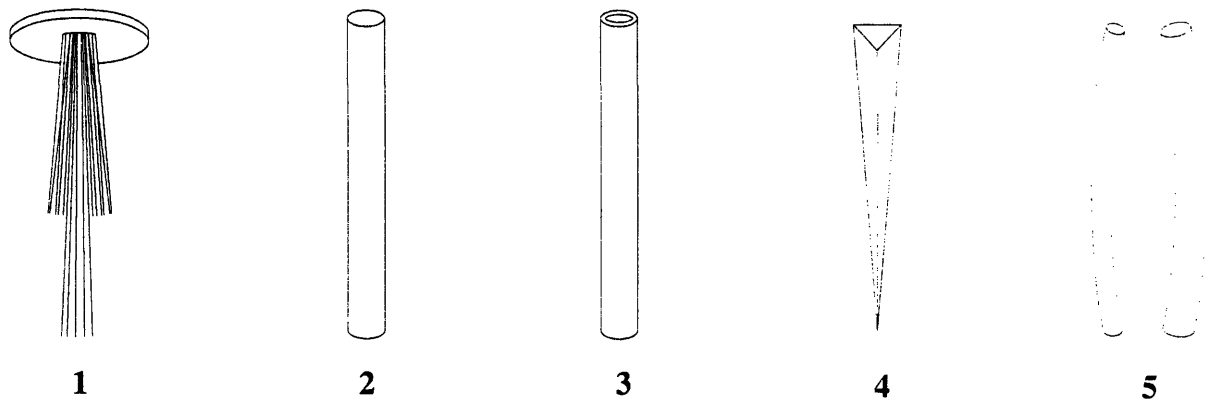

Figure 5-1. 8 Concepts for Auger Attachments

The first design was presented earlier in 5.1.3.1. In this design, the attachments are wound in a spiral fashion around a drum, or placed on the edge of an auger flight. In each attachment, an inner region of dense, stiff bristles (or rubber fingers) would be supplemented by an outer region of less populous, more compliant bristles (or rubber fingers). The outer, less populous portion (long bristles) would be able to clear debris from the surface, while the inner, more populous bristles would act as an auger flight or (if used with a rigid auger core) an extension of an auger flight.

The attachment in design two would be made from a piece of constant diameter elastomeric chord. Making a "finger" from the chord would be as simple as measuring it and cutting it with a blade.

Similar to design two, design three would be a piece of elastomeric tubing. The thought in proposing this design was that for the same size and material, a piece of tubing would be more compliant than a piece of solid chord. This would be an option if a piece of chord could not be

found with the needed material properties and dimensions. Concept three was a secondary option to the chord because it was slightly more expensive.

Design four shows a generalization of a piece of elastomer with variable cross section. Many times the cross sections of components are varied for constant or variable stress. A good example is the assembly tabs (used in snap together joints) which hold some computer keyboards together. The author thought that by using the non-linear properties of an elastomer and a variable cross section, an appropriate compliance (perhaps with variable deflection) could be designed.

Concept five came to the author while watching a Norelco™ shaving commercial. The design of Norelco™ razors uses a "lift and cut" system to give a closer shave. The author thought it possible that a "move and pluck" system might work well for thick grass or areas with embedded debris. In reference to design five, note the two pieces of elastomeric chord of different cross sectional area.

We will assume the attachments of design five are mounted on a rotary member such that the rightmost (thicker) piece of chord engages the surface first. When this happens, the thicker chord moves the grass out of the way. As the chord would be made "curved backwards" (under no load), it will be able to move the grass out of the way without picking up or substantially moving pieces of debris. Its function was only to comb the grass and move it aside.

Once the thicker chord has moved the grass aside, the more compliant aft chord reaches into the grass, engages the debris, and, after being bent back some, flicks the debris onto the surface. With the pieces of debris on top of the grass, they would more easily be captured by the auger.

Table 5-1. 3 Selection Matrix for Auger Attachments

Criteria	1 = good, 3 = fair, 5 = poor					Weight %
	<u>1</u>	<u>2</u>	<u>3</u>	<u>4</u>	<u>5</u>	
Will it work for sure?	2	2	2	2	3.5	40
Cost	4	1	2	5	4	10
Availability	5	1	1	5	2	30
Durability	2	3	3	3	3	10
Easy to make	3	1	1	4	3	10
Weighted Grade	3.2	1.6	1.7	3.5	3.0	-----

These concepts were discussed with Juli King, a sales associate of Green Rubber. After hearing Mrs. King's thoughts, the grades seen in Table 5-1.3 were assigned. The comments which follow explain some of the factors which influenced the grading.

Design 1 - - cost, these bristles will be expensive unless ordered in very large quantities
 - availability, special two part bristles or similar not readily available

Design 2 - + cost, chord was inexpensive
 + availability, one week lead time
 + easy to make, just cut to shape

Design 3- + availability, one week lead time
 + easy to make, just cut to shape

Design 4 - - cost, minimum order of 500 feet plus tooling charge

- availability, two months lead time minimum
- must make tooling and dies, need practice runs

Design 5 -

- will it work, not sure "move and pluck" system will work.
- cost, uses two pieces of chord

Design two was chosen, but will be used somewhat modified. The design of the chord will be made to resemble the frontal chord in design five so that it would be less aggressive on the surface.

5.1.5.2 Concepts For Fastening Attachments to the Auger

Design one was to be a strip of molded elastomer. Ideally, the strip would be made such that it may be attached to the edge of an auger (wrapped in a spiral) without causing "kinking." The strip would be held on the edge of the flighting by fastening bolts every four to five "fingers."

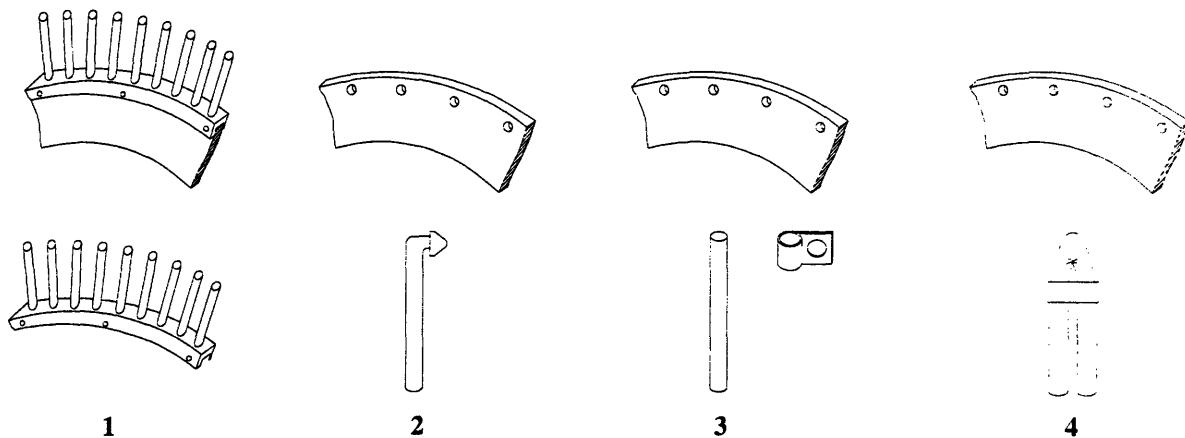

Figure 5-1. 9 Fastening Concepts

Design two was proposed by Professor Slocum. The attachments were to be molded in a shape such that once the knobs were popped through holes in the auger flighting, they could not slip back through, or rotate in the hole.

The third design connects the attachment to the auger flighting via a cable guide and fastener. The attachment would slide into the cable guide, leaving four to six inches free. This assembly would be placed on the side of the auger flighting such that the hole in the cable guide lines up with the hole in the flight, then the fastener would be run through and tightened.

In the fourth design, the attachment would run through a hole in the flighting of the auger and doubled over. A clamp would be placed on the doubled over component forming essentially two independent "fingers." A variation of this design was originally to be used with the "move and pluck" attachment design, but can be modified for use in this case.

Table 5-1. 4 Selection Matrix for Attachment Fastening Method					
1 = good, 3 = fair, 5 = poor					
<u>Criteria</u>	<u>1</u>	<u>2</u>	<u>3</u>	<u>4</u>	<u>Weight %</u>
Machining	1	3	3	4	30
Component Cost	4	5	4	3	15
Availability	5	4	2	2	40
Durability	3	2	2.5	4	15
Weighted Grade	3.4	3.4	2.7	3.1	----

The comments which follow explain some of the factors which influenced the grading.

Design 1

- + machining, holes are to be drilled every four to five "fingers"
- component cost, custom moldings are expensive
- availability, must have time to make molds

Design 2

- machining, need as many holes as "fingers"
- component cost, custom molds can be expensive
- availability, must make molds, but less complex than design 1

Design 3

- machining, need as many holes as "fingers"
- component cost, multiple pieces and fasteners needed
- + availability, available in most hardware shops
- durability, plastic cable guide may degrade in sunlight or crack in cold

Design 4

- machining, need as many holes as "fingers"
- component cost, multiple pieces
- + availability, available in most hardware shops
- durability, plastic cable guide may degrade in sunlight or crack in cold weather

Design three was chosen for the prototype. In mass production, obtaining the original molds and performing trial runs would not count as heavily against designs one and two in an analysis. Ideally, one of these designs would be used in a production model.

5.1.6 Auger Power Estimation

No guide lines could be found for estimating auger power of this application. Formulas for power consumption were derived using simplified models with assumptions which would overestimate the required power. Later, an auger catalog with power information was found. In the first part of this section, the original calculations and derivations will be discussed. Then the estimates from the original calculations will be compared with those from the auger catalog.

5.1.6.1 Auger Power from Simplified Derivation

The power needed to run the auger was split into two parts, the power needed to overcome the friction force at the ground/auger interface, and the power needed to convey the debris. Friction between the conveyed material and the auger flights, conveyed material and the trough, and the conveyed material and the ground was neglected. Assumptions and models used in the calculations follow.

Table 5-1. 5 Description of Variables and Assumed Values

D	outer auger diameter (with attachments)	16 inches
F_n	normal force per contact point at surface	2 lbf
γ_{l-a}	specific weight of air and leaf mixture	0.53 lbf/ft ³
l_a	auger length (original guess)	47.75 inches
ω	maximum auger speed (estimate)	210 rpm
P_r	auger pitch	16 inches
μ	rubber/ground coefficient of friction	1.0 (overestimate)
N	number of flights	2
L_t	trough loading (% of auger full of material)	25%
B	number of contact points per flight	3

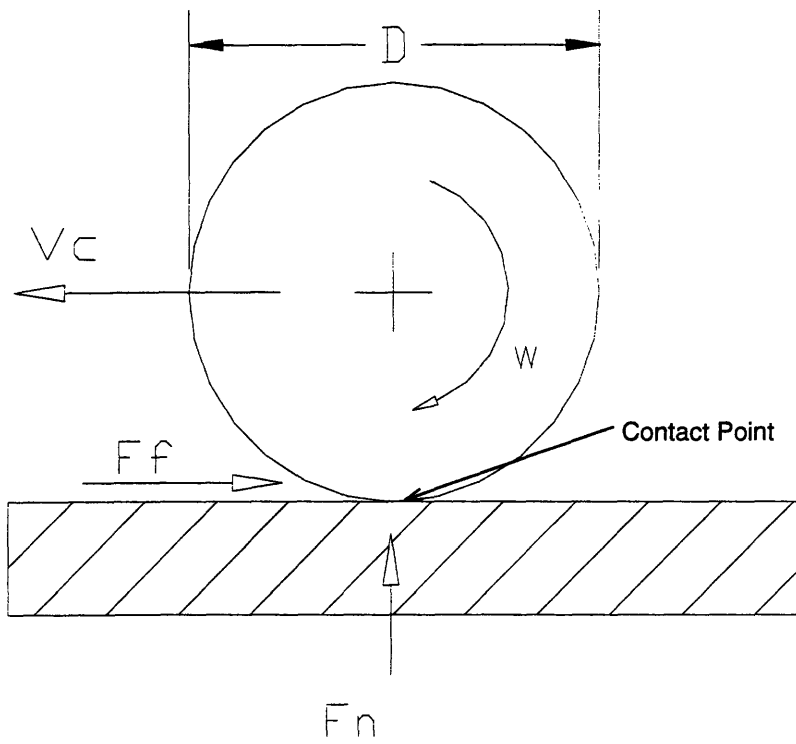

Figure 5-1. 10 Side Illustration Of Simplified Auger Model

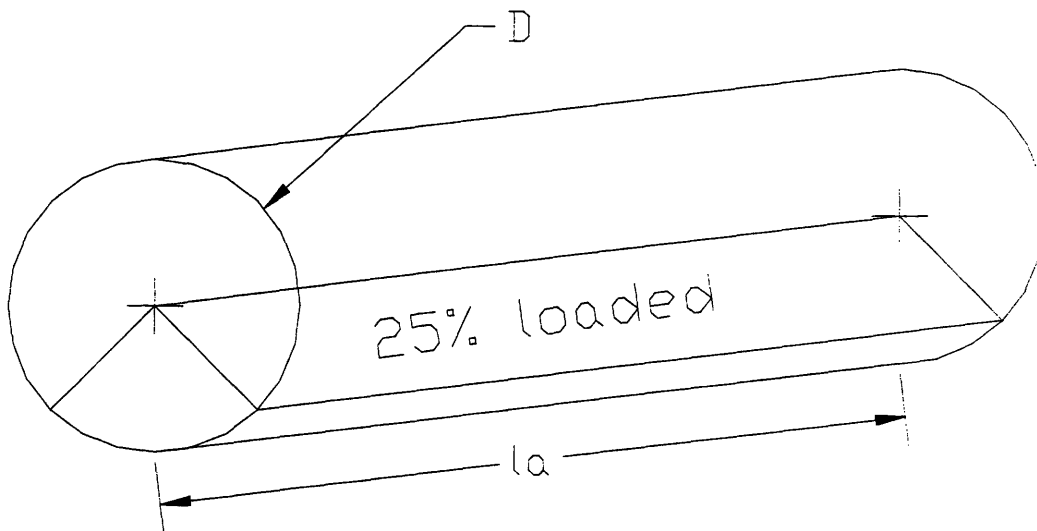

Figure 5-1. 11 Trough Loading of Simplified Auger Model

The spread sheet used to do the power calculations is inserted below.

Values were chosen such that they would overstate power requirements.

auger diameter	D	16.0	in	{reference Fig. 5-1.10 & 5-1.11}
normal force per contact pt.	F_n	2.0	lbf	
specific weight (leaves)	γ_l	9.2	lbf/ft ³	
auger length	l_a	47.8	in	
maximum auger speed	ω	210.0	rpm	
pitch	P_r	16.0	in	
μ rubber/ground	μ	1.0	---	
number of flights	N	2.0	---	
contact points per flight	B	3	---	
cleaner velocity	V_c	5	mi/hr	

Friction Power = Total friction force at the point of contact multiplied by the relative velocity of the point of contact with respect to the ground.

$$\begin{aligned}
 H_{af} &= B \mu F_n N (V_c + (D/2) \omega) \\
 &= 0.48 \text{ hp} \quad \text{Friction power} \\
 &= 0.36 \text{ kW}
 \end{aligned}$$

(continued on next page)

The conveying power was estimated by assuming the auger lifted (vertically) leaves stored within 25% of the auger. This was to simulate moving the leaves across the ground (at a coefficient of friction equal to 1.0).

Conveying Power = Weight of leaves stored in one quarter of the auger multiplied by the velocity at which it is traveling.

$$H_{ac} = (\text{volume of auger}) (\text{specific weight of leaves}) (\text{transport velocity})$$

$$= (\text{Force}) (\text{velocity})$$

$$= \left\{ \left[(L_t)(1/4) (\pi) D^2 l_a \right] [\gamma] \right\} \{P_r \omega\}$$

$$= 0.11 \quad \text{hp}$$

Conveying Power

$$= 0.08 \quad \text{kW}$$

Total power required by the auger = Friction power + Conveying Power

$$H_{af} + H_{ac} = 0.59 \quad \text{hp}$$

$$= 0.44 \quad \text{kW}$$

Total Power

5.1.6.2 Auger Power from Auger Catalog

A catalog containing formulas for power requirements was found after components for the prototype power train had been ordered. An analysis using these formulas was performed to determine if the power assessed using the previous derivation was correct.

Martin catalog analysis for auger power

D_{ma}	Auger Diameter	1.33	ft	
L_{ma}	Auger Length	3.98	ft	
ω	Auger Speed	210	rpm	
F_d	Conveyor Diameter Factor	106	----	Martin Catalog, Table 1-12
F_b	Hanger Bearing Factor	1.00	----	Martin Catalog, Table 1-13
F_f	Flight Factor (for trough loading = 25%)	1.00	----	Martin Catalog, Table 1-14
F_m	Material Factor *	1.50	----	Martin Catalog, Table 1-2
F_p	Standard Paddles Per Pitch (no paddles)	1.00	----	Martin Catalog, Table 1-15
F_o	Overload Factor (function of Hpm & Hpf)	3.00	----	Martin Catalog, Table 1-16
e	Drive Efficiency (for gear motor with chain)	0.87	----	Martin Catalog, Table 1-17
P_{ma}	Auger Pitch	1.33	ft	
γ_{la}	Specific Weight of Air-Leaf Mixture	0.53	lb/ft ³	
C	Required Capacity			
	$C = P_{ma} \times \omega \times 0.25 \times \frac{\pi}{4} \times D^2$	36847	ft ³ /hr	

*Note: Material Factor, F_m , assumed 1.5 (Martin recommendation for wood shavings, value for leaves not quoted)

Power to Overcome Friction

$$HP_f = [L_{ma} \times \omega \times F_d \times F_b] \times (1.0 \times 10^{-6}) = 0.09 \text{ hp}$$

$$= 0.07 \text{ kW}$$

Power to Convey Material

$$HP_m = [C \times L_{ma} \times \gamma_{la} \times F_f \times F_m \times F_p] \times (1.0 \times 10^{-6}) = 0.12 \text{ hp}$$

$$= 0.09 \text{ kW}$$

Total Power

$$HP_{ma} = [HP_f + HP_m] \times F_o \left(\frac{1}{e}\right) = 0.71 \text{ hp}$$

$$= 0.53 \text{ kW}$$

5.1.6.3 Comparison of Derived Power Estimate and Catalog Estimate

Table 5-1. 6 Results of Derived and Catalog Power Calculations	
	<u>Power</u>
Derived Power Estimate	0.59 hp (0.44 kW)
Auger Catalog Estimate	0.71 hp (0.53 kW)
Percent Difference (catalog as reference)	-17%

The difference between the two estimates was significant, so the manufacturer of the catalog was contacted and questioned about the nature of their equations. An engineer at Martin, Shawn Surbey, said that the overload factor, F_o , was put into the catalog estimate to assure that the auger would not stop when a lump of material jammed between the flighting and the trough. Mr. Surbey said that if lumps of material were not an issue, then the overload factor may not be necessary. As the auger in this machine was to have compliant flighting, there will be no danger of jamming. If the overload factor was dropped from the auger catalog calculation, the required power becomes 0.24 hp (0.18 kW).

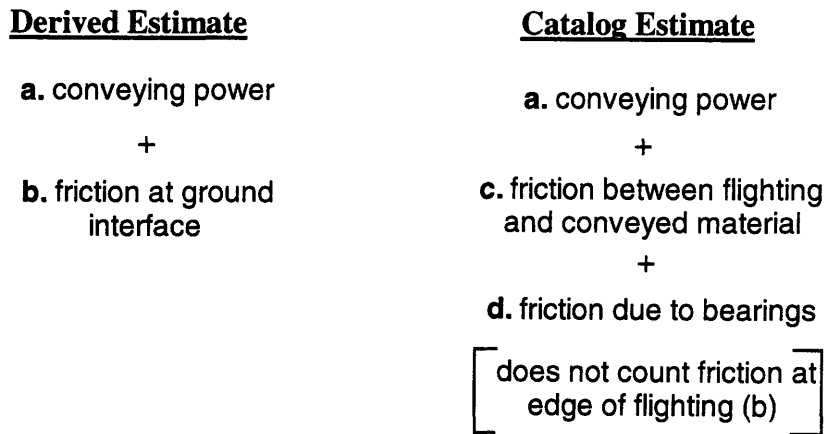

Figure 5-1. 12 Components of Auger Power Estimates

The revised catalog estimate (without F_o) was different than the derived estimate because the two are fundamentally different. The original estimate neglected friction in the bearings and

counted friction at the ground interface, while the friction power from the catalog estimate counted only friction in the bearings. Also, the derived estimate neglected friction between the flighting and material, whereas the catalog values did not. A better estimate can be obtained by combining ground friction from the derived estimate with the catalog conveying and friction estimates (without F_o).

Final Estimate

- a. conveying power
- +
- b. friction at ground interface
- +
- c. friction between flighting and conveyed material
- +
- d. friction due to bearings

Figure 5-1. 13 Components of Final Auger Power Estimate

Using this method, the estimated power consumption was 1.19 hp (0.89 kW). Luckily, the hydraulic system which was designed with reference to the derived estimate was purposely oversized and could provide the new estimated power.

5.2 Vacuum System

5.2.1 Air Flow Specifications

When material is captured by a nozzle, a sufficient velocity must be maintained at the nozzle entrance for the system to be effective. This was learned when advice was sought from John Corely, a plant engineer at the John Deere Waterloo Works (Mr. Corely is responsible for a host of the plant's ventilation systems). Mr. Corely said that the most important factor to design for, would be the velocity of the air at the nozzle entrance, or capture velocity. He could not recommend a suitable velocity for this application, but did refer to a book, *Design of Industrial Ventilation Systems*. In this book, there were no recommendations on a capture velocity for debris (leaf) cleaning, so the recommended velocity for a similar material, wood shavings, was used in the calculations. For wood shavings, it was recommended that the capture velocity be approximately 3000 ft/min (Alden-1, 81).

5.2.2 Fan Type

The initial concept used an axial flow fan because such fans are efficient. Later, it was found that material handling fans (fans which pass material and shred it) are usually centrifugal rather than axial. An axial fan could have been custom made for the debris cleaner, but this choice became less attractive after considering the characteristics of centrifugal and axial fans as shown in Tables 5-2.1 and 5-2.2.

Table 5-2. 1 Positive Characteristics of Centrifugal and Axial Fans

Centrifugal Fans

Axial Fans

- | | |
|-----------------------------------------------------------------------------------------------------------------------------------------------------------------------------------------------------------------------------------------------------------------------------------------------------------------------------------------------|-----------------------------------------------------------------------------------------|
| <ul style="list-style-type: none">• better able to cope with fluctuating operating conditions• better able to withstand the impact of debris• produce higher static pressure at lower speeds• harder to clog• may operate at any speed without stalling• easier to drive fan shaft | <ul style="list-style-type: none">• more efficient• more compact |
|-----------------------------------------------------------------------------------------------------------------------------------------------------------------------------------------------------------------------------------------------------------------------------------------------------------------------------------------------|-----------------------------------------------------------------------------------------|

Table 5-2. 2 Negative Characteristics of Centrifugal and Axial Fans

Centrifugal Fans

Axial Fans

- | | |
|-----------------------------------------------------------------------------------------|-----------------------------------------------------------------------------------------------------------------------------------------------------------------------------------------------------------------------------------------------------------------------------------------------------------------------|
| <ul style="list-style-type: none">• less efficient• less compact | <ul style="list-style-type: none">• must avoid certain speed ranges to prevent stall• require higher speeds to produce desired static pressures• create more noise at such fan speeds• harder to drive fan shaft• fan blades break off easier when impacting debris |
|-----------------------------------------------------------------------------------------|-----------------------------------------------------------------------------------------------------------------------------------------------------------------------------------------------------------------------------------------------------------------------------------------------------------------------|

It was obvious that a centrifugal fan should be used, but which type? All debris cleaners seen to this point had used paddle fans. The reason for this, as reported by Ric Johnson of Blower Application Company Incorporated, was that paddle fans are more effective at shredding

and conveying materials than other types of centrifugal fans. Instead of making a fan or purchasing an industrial grade material handling fan, the fan from a Trac-Vac™ model 2001 truck loader (truck loaders vacuum up leaves into a truck) was used. A picture of the fan is shown in Figure 5-2. 1.

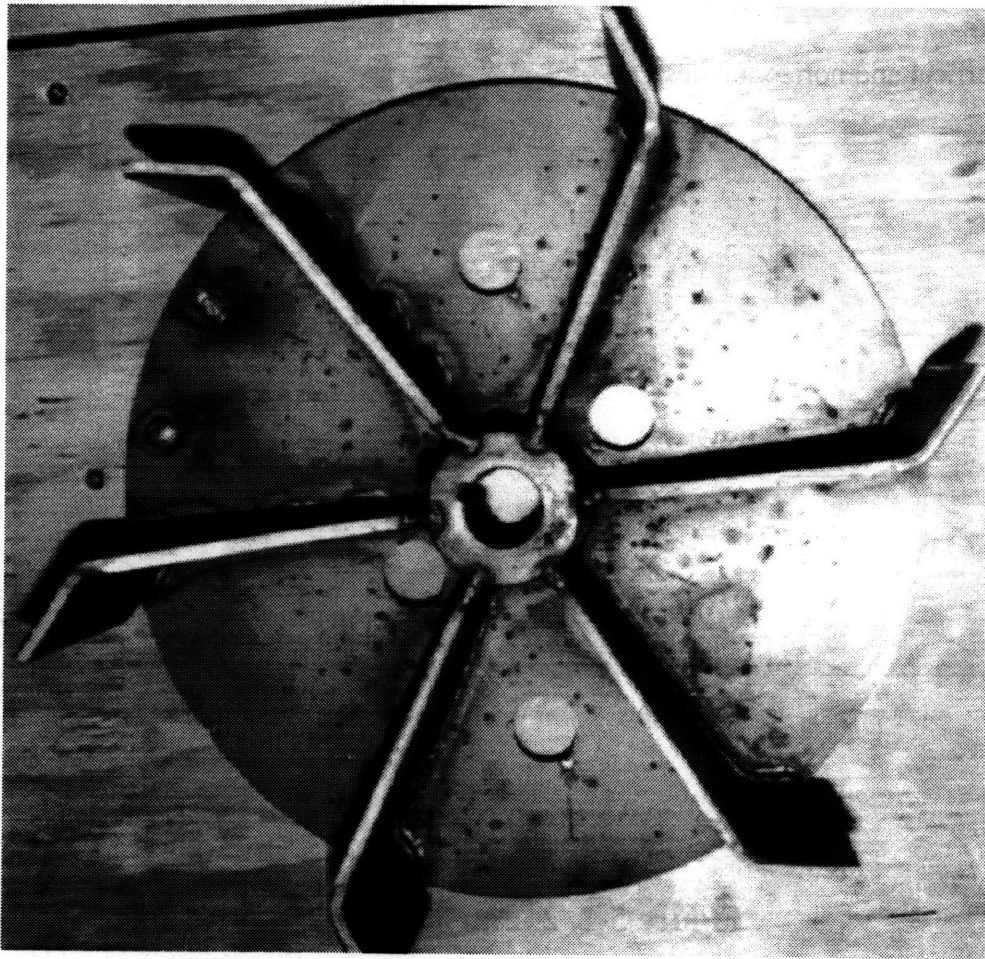

Figure 5-2. 1 Fan Blade Assembly

5.2.3 Prototype Pneumatic Power Estimation

Estimates for power to run the fan were needed before the drive train could be designed. The air flow was first modeled using the configurations shown in Figure 5-2.2. The first design used a fan with the shaft oriented vertically and the second, a fan with the shaft orientated horizontally. For the remainder of this section, the two designs shall be referred to respectively as the vertical and horizontal designs.

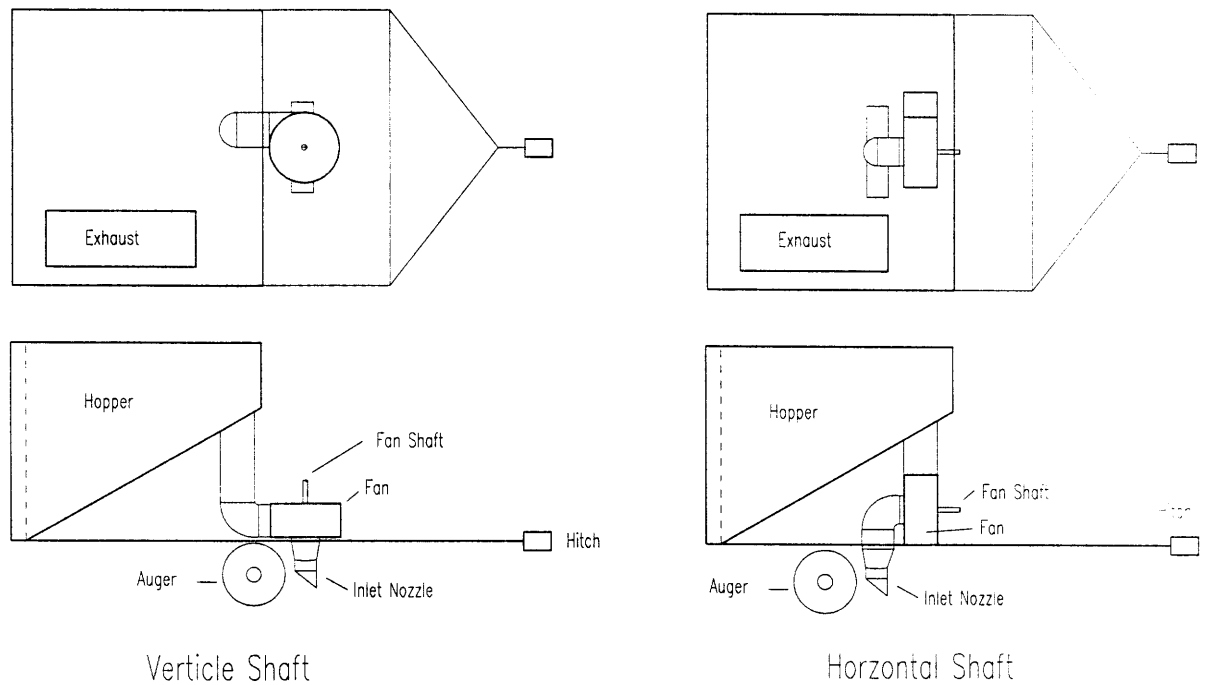

Figure 5-2. 2 Fan Shaft Configurations

The initial thought was to use the vertical design because the elbow in the horizontal design would clog easier as debris entering it would not have been shredded. The vertical design would not have this problem since the debris would be shredded in the fan before passing through the elbow. Also, the loss coefficient for the nozzle in the horizontal design (nozzle and elbow combined) was much larger than the loss coefficient in the vertical design (nozzle and

elbow separate)* (Alden-2, 84). The only factor against the vertical design was the fact that it would be more difficult to drive. After much time had been spent brainstorming cost effective concepts for the drive system of the vertical design, the two designs were modeled to determine if the power savings from the vertical design warranted the extra effort it would take to design and build a more complex drive train.

5.2.3.1 Vertical Fan Power Model

The model used for the vertical design is shown in Figure 5-2.3. The air/leaf mixture was treated as a fluid (rough approximation). Then, using the model, Bernoulli's equation, and loss factors for the various components, the power required to run the fan was estimated.

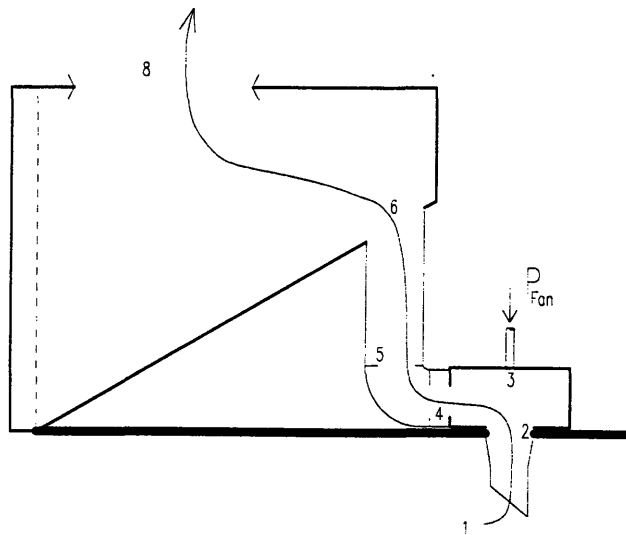

Figure 5-2. 3 Vertical Fan Shaft Model

The loss in the system is given by equation 5-2.1. Fan loss is later counted in the fan efficiency.

$$h_L = \left(\frac{1}{2g} \right) \times \left(K_{1-2}(V_1)^2 + K_{4-5}(V_4)^2 + K_{5-6}(V_6)^2 + K_6(V_6)^2 + K_8(V_8)^2 \right) \quad \text{Equation 5-2. 1}$$

* The reason behind the difference in loss factors was not clearly explained in the reference. Before production would start, the two systems should be built and tested to determine if a difference does exist.

Where:

- g = gravitational constant
- K_i = loss factor at point i
- K_{m-n} = loss factor between points m and n
- V_i = duct velocity at point i

The flow rate, Q , in the system at any point is described by equation 5-2.2.

$$Q = A_1 V_1 = A_i V_i \quad \text{Equation 5-2. 2}$$

Combining equations 5-2.1 and 5-2.2 gives another equation for the loss in the system.

$$h_L = \left(\frac{1}{2g} \right) \times \left\langle K_{1-2} \left(\frac{A_1 V_1}{A_1} \right)^2 + K_{4-5} \left(\frac{A_1 V_1}{A_4} \right)^2 + K_{5-6} \left(\frac{A_1 V_1}{A_6} \right)^2 + K_6 \left(\frac{A_1 V_1}{A_6} \right)^2 + K_8 \left(\frac{A_1 V_1}{A_8} \right)^2 \right\rangle \quad \text{Equation 5-2. 3}$$

Equation 5-2.3 simplifies to a more manageable equation 5-2.4.

$$h_L = \left(\frac{Q^2}{2g} \right) \times \left\langle \frac{K_{1-2}}{A_1^2} + \frac{K_{4-5}}{A_4^2} + \frac{K_{5-6}}{A_6^2} + \frac{K_6}{A_6^2} + \frac{K_8}{A_8^2} \right\rangle \quad \text{Equation 5-2. 4}$$

Power required to run the system is given by equation 5-2.5.

$$P_{Fan} = \frac{\gamma_{l-a} \times h_L \times Q}{\eta} \quad (\text{Jorgensen, 24-11}) \quad \text{Equation 5-2. 5}$$

Where:

- γ_{l-a} = specific weight of debris (see appendix)
- η = fan efficiency (value not known, assumed)

Equation 5-2.4 and 5-2.5 combined, give the final equation for required power, equation 5-2.6.

$$P_{Fan} = \left(\frac{\gamma_{l-a} \times Q^3}{2\eta g} \right) \left(\frac{K_{1-2}}{A_1^2} + \frac{K_{4-5}}{A_4^2} + \frac{K_{5-6}}{A_6^2} + \frac{K_6}{A_6^2} + \frac{K_8}{A_8^2} \right)$$

Equation 5-2. 6

Equation 5-2.6 shows that when losses are taken into account, the power required to run the system was not proportional to the flow rate as previously thought, but to the cube of the flow rate. This is important when considering that the new design may cut the required flow rate by up to 50%.

The preceding equations were put into a spread sheet which calculated the individual losses and expressed each of them as a percentage of the total loss. At later stages in the design, “what if” games can be played with the system parameters to minimize the losses which make up the largest percentage of the total loss. The spread sheet is shown on the following page. Note that the values for duct lengths and diameters used in the spread sheet are approximate as the final dimensions of the debris cleaner were not known at the time of calculation.

Reference Figure 5-2.3 for definition of subscripted numbers

Input

Capture velocity	V_1	3000	ft/min
Gravitational constant	g	32.2	ft/s ²
Nozzle width	N_w	24.0	inches
Nozzle depth	N_d	4.0	inches
Friction coefficient	$f(Re)$	0.21	---
Length 4-5	l_{4-5}	12.0	inches
Diameter @4	D_4	10.0	inches
Length 5-6	l_{5-6}	22.0	inches
Diameter @5	D_5	10.0	inches
Fluid specific weight	γ_a	0.53	lb/ft ³
Fan efficiency	η	0.60	---
Exhaust width	w_8	10.0	inches
Exhaust depth	d_8	24.0	inches
Exhaust obstruction	α	50	%

Spread Sheet for Vertical Fan Shaft Design Power Estimate

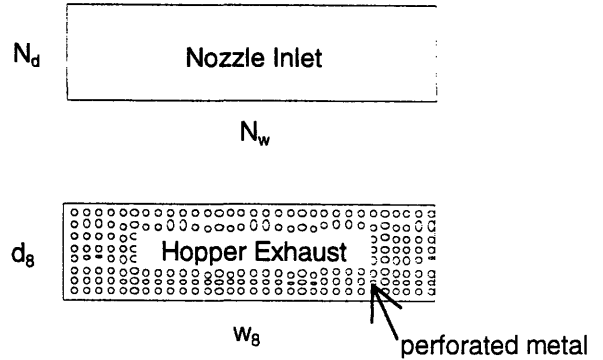

Note: Friction coefficient, $f(Re)$, for galvanized sheet metal is nearly constant at 0.21 for the duct velocities seen below.

Note: α accounts for obstruction of exhaust area due to perforated metal

Areas			Velocities			Loss Factors		
A_1	96.0	in ²	V_1	3000	ft/min	K_{1-2}	1.00	----
A_4	78.5	in ²	V_4	3667	ft/min	K_{4-5}	0.25	----
A_5	78.5	in ²	V_5	3667	ft/min	K_5	0.00	----
A_6	78.5	in ²	V_6	3667	ft/min	K_{5-6}	0.46	----
A_8	120.0	in ²	V_8	2400	ft/min	K_6	1.00	----
						K_8	1.00	----

Calculated Values		
System flow rate	Q	2000 ft ³ /min
Inlet area	A_1	96.0 in ²
Outlet area	A_8	120.0 in ²

Power Loss		
Location	Power Loss	% Loss
P_{1-2}	1.4 hp	26
P_{4-5}	0.4 hp	7
P_5	0 hp	0
P_{5-6}	0.8 hp	15
P_6	1.7 hp	31
P_8	1.1 hp	20
Fan Power = Σ	5.4 hp	
	4.1 kW	
Static Pressure =	3.5	in H ₂ O

5.2.3.2 Horizontal Fan Power Model

The model below was used to estimate the power requirements for the horizontal design.

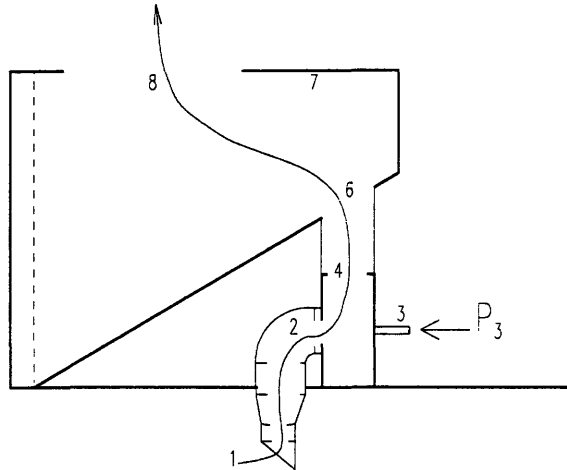

Figure 5-2. 4 Horizontal Fan Shaft Model

The equation for the system loss is,

$$h_L = \left(\frac{1}{2g} \right) \times \left(K_{1-2}(V_1)^2 + K_{4-6}(V_6)^2 + K_6(V_6)^2 + K_8(V_8)^2 \right) \quad \text{Equation 5-2. 7}$$

Following the same procedure as in section 5.2.3.1, equation 5-2.7 reduces to,

$$P_{Fan} = \left(\frac{\gamma_{l-a} \times Q^3}{2\eta g} \right) \left(\frac{K_{1-2}}{A_1^2} + \frac{K_{4-6}}{A_6^2} + \frac{K_6}{A_6^2} + \frac{K_8}{A_8^2} \right) \quad \text{Equation 5-2. 8}$$

Equation 5-2.8 was used in the following spread sheet to calculate the power needed to drive the horizontal system

Reference Figure 5-2.4 for definition of subscripted numbers

Input

Capture velocity	V_1	3000	ft/min
Gravitational constant	g	32.2	ft/s ²
Nozzle width	N_w	24.0	inches
Nozzle depth	N_d	4.0	inches
Friction coefficient	$f(Re)$	0.21	---
Length from 4 to 6	l_{4-6}	4.0	inches
Diameter at 4	D_4	10.0	inches
Fluid specific weight	γ_a	0.53	lb/ft ³
Fan efficiency	η	0.60	---
Exhaust port width	w_8	10.00	inches
Exhaust port depth	d_8	24.00	inches
Exhaust obstruction	α	50	%

**Spread Sheet for Horizontal Fan Shaft
Design Power Estimation**

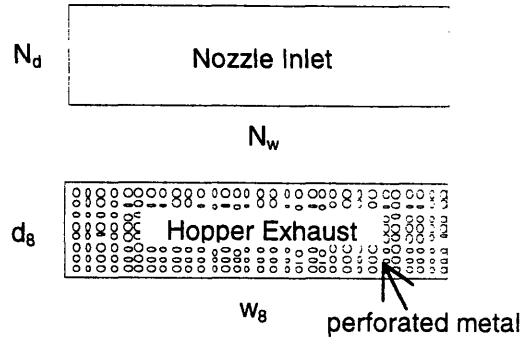

Note: α accounts for obstruction of exhaust area due to perforated metal

Note: Friction coefficient, $f(Re)$, for galvanized sheet metal is nearly constant at 0.21 for the duct velocities seen below.

Areas			Velocities			Loss Factors		
A_1	96.0	in ²	V_1	3000	ft/min	K_{1-2}	2.08	----
A_4	78.5	in ²	V_4	3667	ft/min	K_{4-6}	0.08	----
A_6	78.5	in ²	V_6	3667	ft/min	K_6	1.00	----
A_8	120.0	in ²	V_8	2400	ft/min	K_8	1.00	----

Calculated Values				Power Loss			
System flow rate	Q	2000	ft ³ /min	<u>Location</u>	<u>Power Loss</u>		<u>% Loss</u>
Inlet area	A_1	96.0	in ²	P_{1-2}	4.3	hp	47.9
Outlet area	A_8	120.0	in ²	P_{4-6}	0.3	hp	2.9
				P_6	3.1	hp	34.4
				P_8	1.3	hp	14.7
				Fan Power = Σ =	9.0	hp	
					= 6.7	kW	
				Static Pressure =	4.3	in H ₂ O	

The power requirements by the two designs are compared in Table 5-2.3.

Table 5-2. 3 Required Power For Horizontal and Vertical Designs

<u>Design</u>	<u>Required Power</u>
Vertical Shaft Design	5.4 hp (4.1 kW)
Horizontal Shaft Design	9.0 hp (6.7 kW)

The vertical shaft design used 3.6 hp less than the horizontal design. In the vertical shaft design, a smaller, less expensive engine could be used. However, the fifty dollars which could be saved by using a smaller engine would be less than the cost to build the more complex drive system needed to link the fan to a power source. For this reason, the horizontal design was used. The reader should note that this is the design which other debris cleaners use.

The above analysis was completed before hydraulics were chosen to drive the on-board components. With these components, mounting of the vertical shaft design would be much simpler. Use of the vertical shaft fan will be discussed later in section 6.2.

5.2.3.3 Prototype Power Estimation

The prior estimates for fan power were done in the early stages of design with assumed duct lengths and diameters. At the time, this was acceptable as the purpose of the estimates was to help decide which fan configuration to use. When final dimensions of the prototype ductwork were known, the calculations were done again to obtain power estimates to be used in designing the drive train. Figure 5-2.5 shows the model for the prototype. The equations for the horizontal design were used to calculate the required power in the spread sheet which follows.

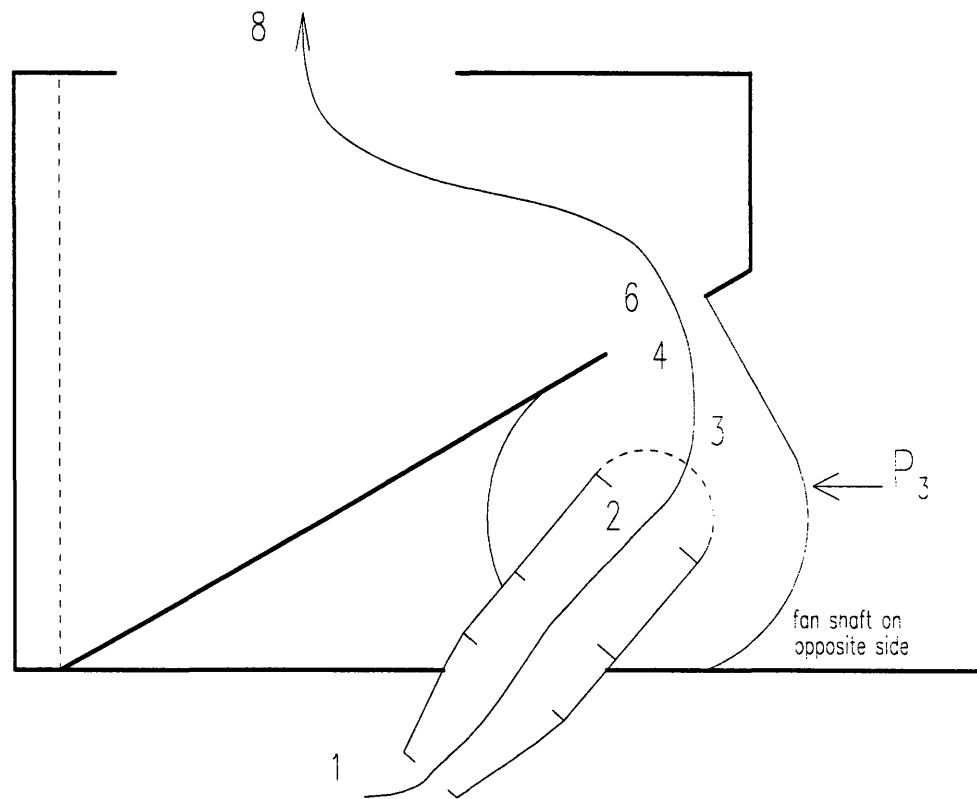

Figure 5-2. 5 Prototype Model for Fan Power Estimation

Reference Figure 5-2.5 for definition of subscripted numbers

Input

Capture velocity	V_1	3000	ft/min
Gravitational constant	g	32.2	ft/s ²
Nozzle width	N_w	24.0	inches
Nozzle depth	N_d	4.0	inches
Friction coefficient	$f(Re)$	0.21	---
Length from 4 to 6	l_{4-6}	0.0	inches
Diameter at 4	D_4	8.0	inches
Fluid specific weight	γ_{f-a}	0.53	lb/ft ³
Fan efficiency	η	0.60	---
Exhaust port width	w_8	10.00	inches
Exhaust port depth	d_8	24.00	inches
Exhaust obstruction	α	50	%

**Spread Sheet for Horizontal Fan Shaft
Design Power Estimation - Prototype**

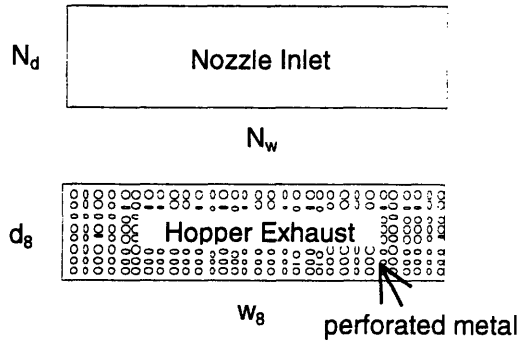

Note: Friction coefficient, $f(Re)$, for galvanized sheet metal is nearly constant at 0.21 for the velocities shown below.

Note: α accounts for obstruction of exhaust area due to perforated metal

Areas			Velocities		Loss Factors		
A_1	96.0	in ²	V_1	3000 ft/min	K_{1-2}	2.08	----
A_4	50.3	in ²	V_4	5730 ft/min	K_{4-6}	0.00	----
A_6	50.3	in ²	V_6	5730 ft/min	K_6	1.00	----
A_8	120.0	in ²	V_8	2400 ft/min	K_8	1.00	----

Calculated Values				Power Loss		
System flow rate	Q	2000	ft ³ /min	<u>Location</u>	<u>Power Loss</u>	<u>% Loss</u>
Inlet area	A_1	96.0	in ²	P_{1-2}	4.3 hp	47.9
Outlet area	A_8	120.0	in ²	P_{4-6}	0 hp	2.9
				P_6	7.6 hp	34.4
				P_8	1.3 hp	14.7
Fan Power = Σ =				13.2	hp	
				=	9.9	kW
Static Pressure =				6.3	in H ₂ O	

The initial horizontal design differs from the prototype design in the following two ways: the lengths between points 4 and 6, and the diameter of the ductwork. Both of these changes were made to accommodate the (larger than expected) Trac Vac™ fan. At first, blue prints obtained from Trac Vac™ showed that the fan would fit as shown in Figure 5-2.4. Later, it was realized that the wrong blueprints had been obtained from the manufacturer. The correct blue prints showed that the fan would not fit as first designed, but as shown in Figure 5-2.5. In this configuration, the fan was connected directly to the hopper, thus eliminating the ductwork between points 4 and 6. The change in duct diameter from 10 inches to 8 inches was made because the fan was equipped with adapters for 8 inch ductwork.

When the new values were put into the spread sheet, the estimated power increased from 9.0 hp (6.7 kW) to 13.2 hp (9.9 kW). This was due to the decreased duct diameter. Decreasing the duct diameter raised the velocities in the ductwork which in turn resulted in higher losses. In a production model, the diameter of the ductwork would be optimized to reduce the system losses.

5.3 Drive Train

5.3.1 System Requirements

From the analyses in previous sections and conversation with lawn and garden distributors, the following requirements were deemed most important for the drive train.

Table 5-3. 1 Drive Train System Requirements

Power:

Fan 13.2 hp (9.9 kW) from section 5.2.3.3

Auger 1.19 hp (0.89 kW) from section 5.1.6.3

Operation:

Safety - of prime importance, failure of system would be very dangerous

Environment - able to operate in dirty/dusty environment with little maintenance

Cost - lowest cost, system will constitute a major part of debris cleaner cost

Prototype: - variable speed on fan and auger, to handle a range of operating conditions

The four concepts developed for the drive train are shown in Figure 5-3.1. Although not shown, there were many (12) other concepts which came from combinations or slight modifications of designs 1, 2, and 3. Little work was put into developing each of the 16 concepts

as they had problems which the fourth did not. The first three shown encompass the basic ideas in the additional 12.

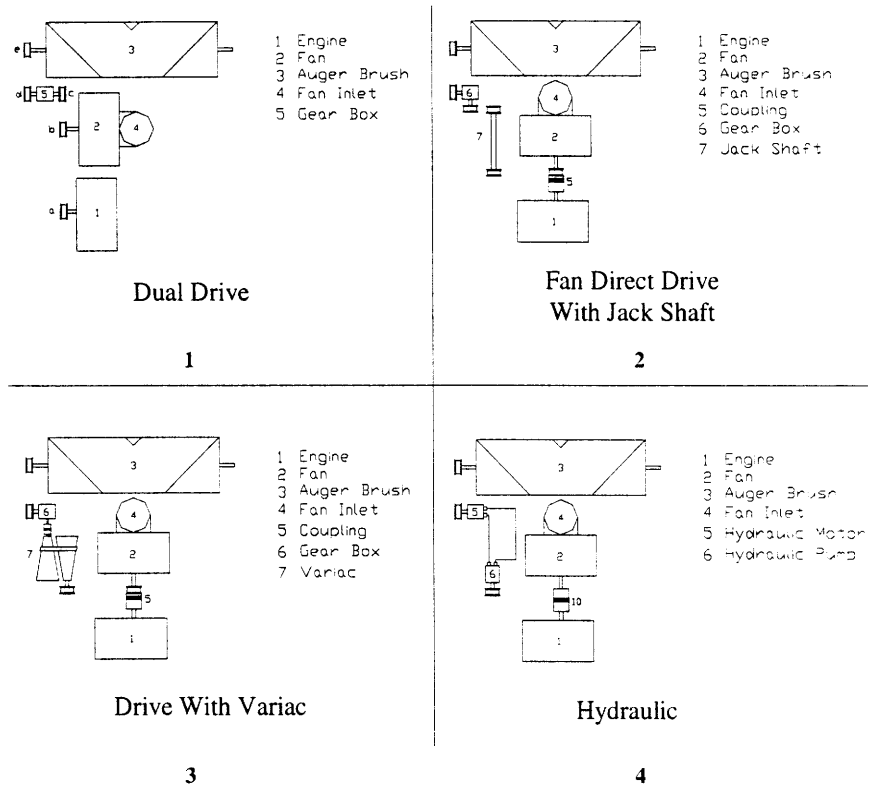

Figure 5-3. 1 Concepts for Drive Train

Designs 1, 2, and 3 were originally the only considered. However, they had problems. First, it would be difficult to measure the power consumed by the fan and auger. Second, to vary the transmission ratio (except in design 3) would be difficult as pulleys would require changing. Later, in an unrelated discussion, Professor Alexander Slocum was talking about powering a vehicle with hydraulics. Both the author and Professor Slocum looked at each other at the same time, realizing that this was a good choice to power the debris cleaner. Making the entire (note, the above shows just the auger hydraulically driven) system hydraulically powered would allow

variable speed control of the components, and make measurements of power consumption easier.

This is discussed in more detail in the following sections.

5.3.2 Engine

An 18 horse power Vanguard engine was donated by the Briggs and Stratton Corporation.

This engine was requested for its following features:

- power - offers more power than estimated in case estimates are low
- two cylinder - a two cylinder operates much smoother than a single cylinder engine
- air cooled - no heat exchange system required to cool engine
- four cycle - more efficient than two cycle engines

The reader should note that similar engines are used on other debris cleaners of comparable size.

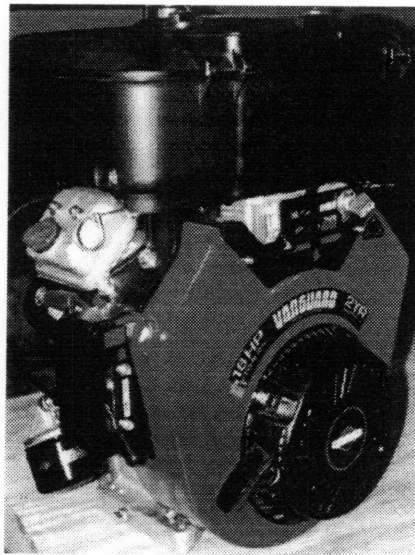

Figure 5-3. 2 Prototype Engine

5.3.3 Hydraulics Development and Modeling

A hydraulic drive system was chosen for three reasons. First, the speeds of the hydraulic motors could easily be varied by changing the flow rate to each motor. Second, the power used by each component of the system could be measured more easily than if the drive train consisted of shafts and gear boxes. The third reason was that two types of end users were targeted for the debris cleaner. The first type would require a cleaner which was self powered by an on board internal combustion engine. The second type would pull the debris cleaner behind a tractor (the hydraulic system of a tractor is usually used to power its pull behind implements). Since one model would have to be hydraulically driven, it would be simpler to produce both models using the same hydraulic system and provisions for easy adaptation to either power source.

5.3.3.1 Basic Hydraulic Theory

A brief explanation of the theory used to design the hydraulic system follows. Equations 5-3.1 and 5-3.2 express the motor torque and required flow rate as functions of system parameters.

$$T = \frac{P_m \times D_m}{2\pi} \quad \text{Equation 5-3. 1}$$

$$Q_m = D_m \times \omega_m \quad \text{Equation 5-3. 2}$$

where,

T	motor torque
Q_m	flow rate
p_m	pressure drop across motor
D_m	motor displacement
ω_m	motor speed

5.3.3.2 Component Selection

Hydraulic motors and pumps were chosen by calculating the displacement needed to deliver the specified power at a given speed for a certain pressure drop. Once a matching component was found, the maximum operating pressure and input torque were checked to see if the selected component could withstand the application. The spread sheet on the following page was made to do the calculations. The components represented in the spread sheet are those which were chosen for the drive system of the prototype. Note the power curve for the prototype engine is also provided.

*eaton h motor: 101-1700

*sauer-sundstrand motor: SNM2 / 14 CI 06

Auger Motor			
motor speed	ω_{AM}	210	rpm
motor power	P_{AM}	1.19	hp
motor efficiency	η_{AM}	0.85	---
motor torque	T_{AM}	357.1	in-lbf
motor displacement	D_{AM}	2.200	in ³
theoretical flow rate	Q_{TAM}	2.00	gal/min
actual flow rate	Q_{AAM}	2.35	gal/min
auger pressure	p_{HYD-a}	1020	psi

Fan Motor			
motor speed	ω_{FM}	3600	rpm
motor power	P_{FM}	13.2	hp
motor efficiency	η_{FM}	0.85	---
motor torque	T_{FM}	231.1	in-lbf
motor displacement	D_{FM}	0.879	in ³
motor flow rate	Q_{TFM}	13.67	gal/min
actual flow rate	Q_{AFM}	16.08	gal/min
fan pressure	p_{HYD-f}	1652	psi

*eaton gear pump: 26007-RZD

Pump			
pump speed	ω_P	3600	rpm
pump efficiency	η_P	0.85	---

Required by system			
required flow rate	Q_{PR}	18.43	gal/min
required displacement	D_{PR}	1.185	in ³
pressure	p_{HYD-P}	1652	psi

Delivered by pump			
flow delivered	Q_{FMA}	18.66	gal/min
displacement	D_{FMA}	1.200	in ³
required power	P_{HYD-P}	17.98	hp

Motor Horsepower Relationship

ω_M rpm	P_{ENGINE} hp
1800	10.5
1900	11
2000	11.8
2100	12.4
2200	12.9
2300	13.6
2400	14.1
2500	14.7
2600	15.4
2700	15.8
2800	16.3
2900	16.8
3000	17.1
3100	17.4
3200	17.5
3300	17.6
3400	17.8
3500	18

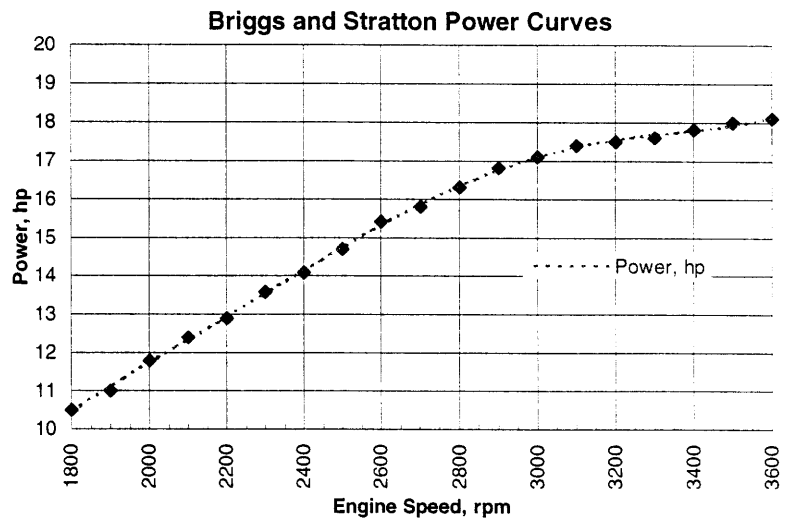

5.3.3.3 Hydraulic System Layout

5.3.3.3.1 First Iteration of Hydraulic System Layout

The first design of the hydraulic system is shown in Figure 5-3.3. The motors were placed in parallel so that each flow (speed) could be varied independently of the other. A ball valve was used to turn the hydraulic system on and off. When open, the ball valve would offer less resistance to the fluid than the other flow paths and the fluid would dump to tank. When closed, fluid would be forced through the system and drive the hydraulic motors. An adjustable relief valve was added to protect the system from pressure spikes.

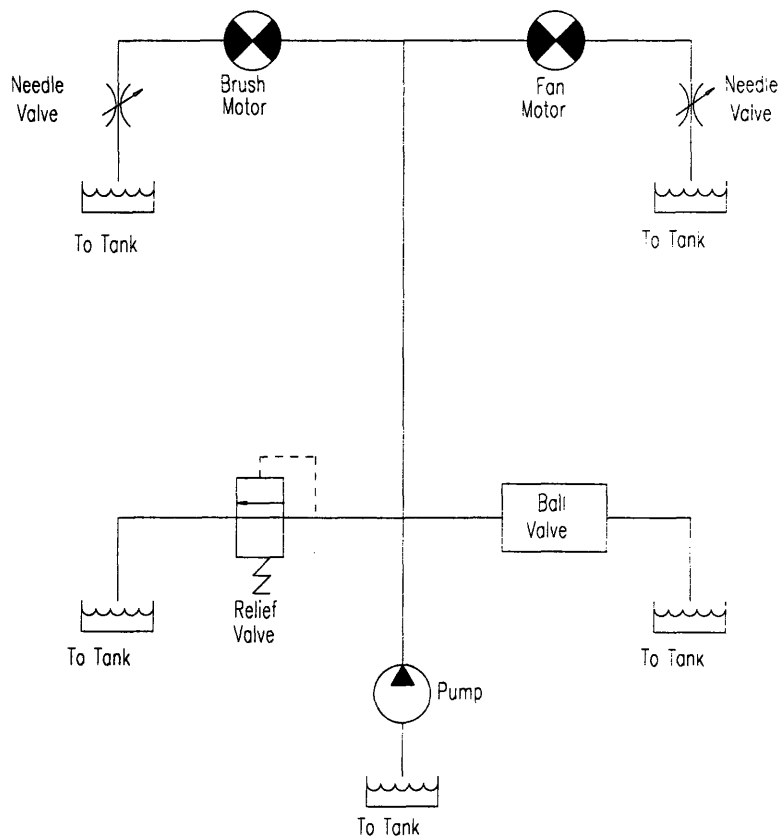

Figure 5-3. 3 First Layout for Prototype Hydraulic System

5.3.3.3.2 Second Iteration of Hydraulic System Layout

The hydraulic system shown in Figure 5-3.3 was taken to Boston Hydraulics where the owner, Mr. Philip Pessa, looked over the design. After some discussion, the layout was changed to the one seen in Figure 5-3.4.

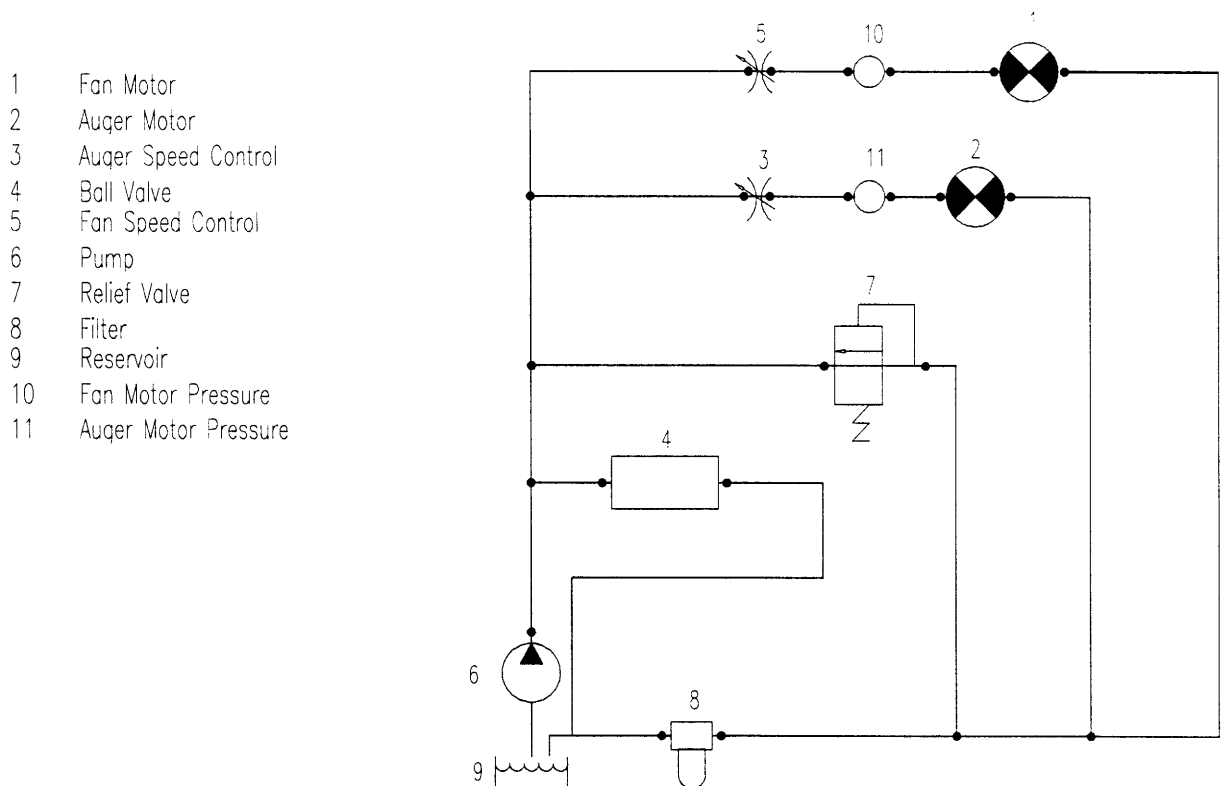

Figure 5-3. 4 Second Layout For Prototype Hydraulic System

This system differs from the last in three ways. First, a filter was added. At first this was not thought necessary because the prototype would not run for long periods of time. However, the filter was added at the request of Professor Slocum with the reasoning that it was better to be safe than sorry.

The second change was the addition of pressure gauges before the hydraulic motors to measure pressure drop. Aft gauges were not needed as Mr. Pessa noted that the pressure following of the motors should be "relatively" close to the tank pressure (assumed atmospheric). With this pressure drop and the speed of the components known, the power used by each component could be calculated.

The third change was the rerouting of the tank dump from the relief hose. This was done at the suggestion of Mr. Pessa. He believed that if the relief valve did not dump directly to tank, it may cause a pressure surge to work backward into the system under certain circumstances.

5.3.3.3 Third Iteration of Hydraulic System Layout

After the second layout had been completed, the author learned of a type of manifold which when used would reduce the number of hoses required from 22 to 10 (shown in bold). Figure 5-3.5 shows the third and final layout for the system. Note that items connected to the left manifold are directly mounted, therefore not needing hoses.

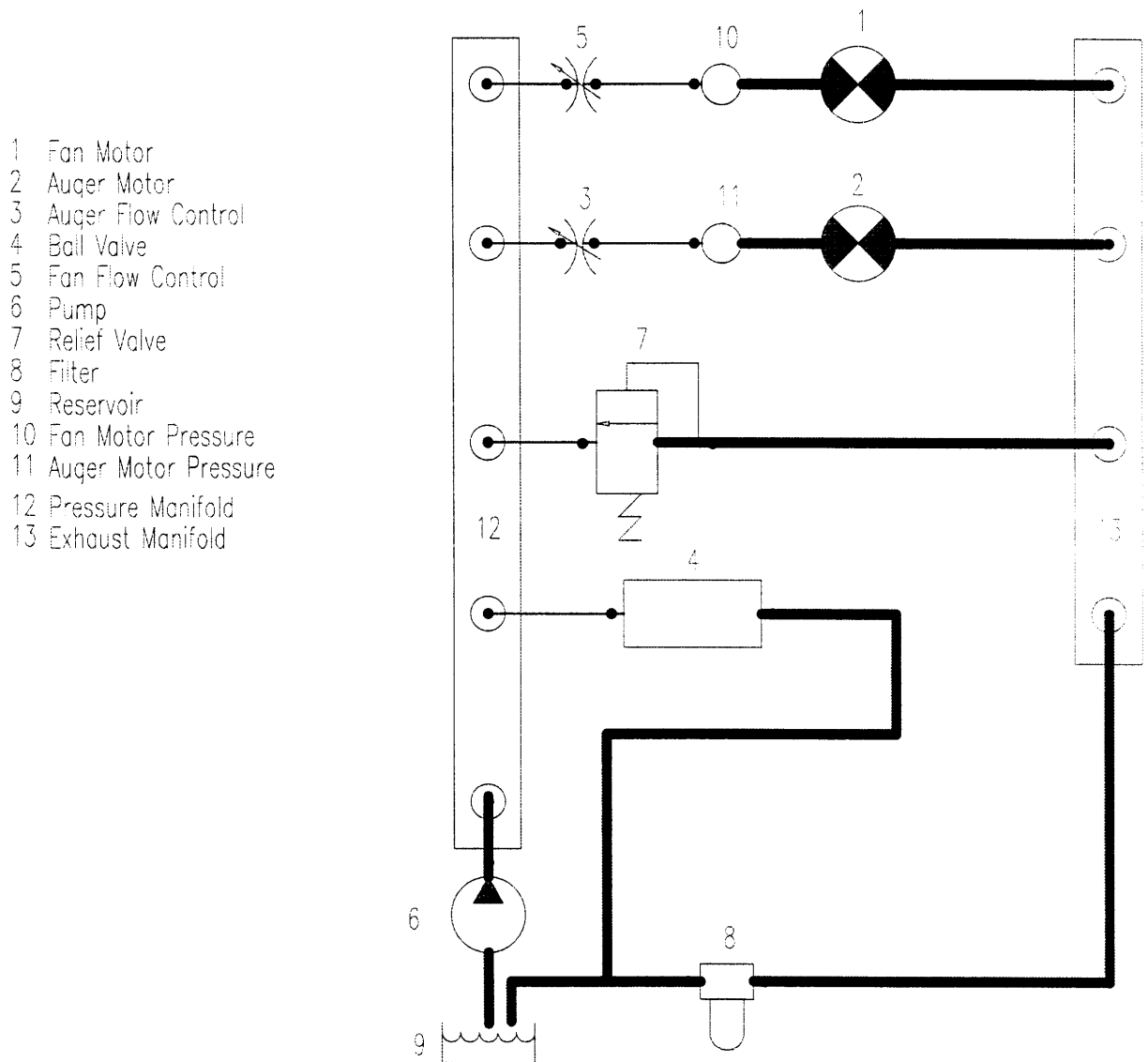

Figure 5-3. 5 Third Layout For Prototype Hydraulic System

5.3.3.3.4 Safety

There were three safety features built into the hydraulic system. The first was the on/off switch, the ball valve. If problems were to arise, the ball valve could be opened to shut the system down. This switch was made readily accessible on the prototype.

The second safety feature was the relief valve. If the fan or auger were to lock up (there was more danger from the fan locking as it had a higher flow rate) the system was protected by a relief valve. Should anything go wrong, the valve would dump directly to tank until the ball valve was opened.

The third feature was the bi-directional flow control valve for the auger. Consider the following, if the auger were to catch on some object such that the auger was forced to rotate opposite to the direction it was being driven, the hose between a uni-directional flow control valve (not allowing back flow) and the motor would experience a pressure surge. This could cause hose failure and possible injury. Placing a relief valve at this location was a possibility, but it was less expensive to use a valve which would allow back flow. Depending upon the severity of the back flow, fluid would either flow back into the manifold then through the fan motor, or cause the relief valve to blow.

5.3.4 Fan Drive

5.3.4.1 Fan Drive Concepts

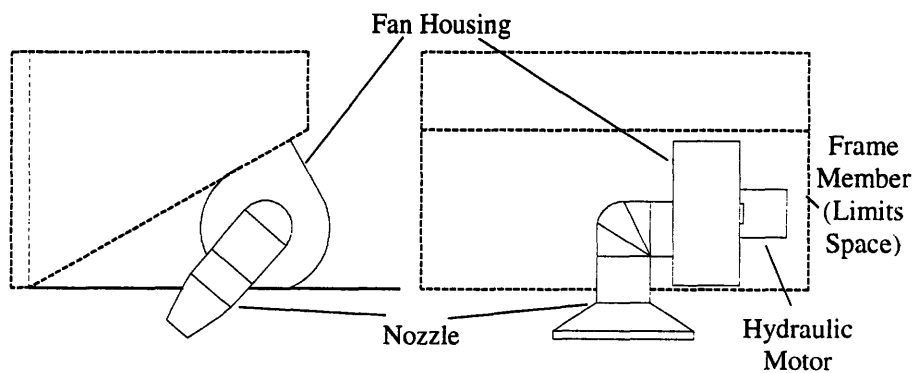

Figure 5-3. 6 Position of Prototype Fan Housing

Originally, the hydraulic motor was to attach to the fan housing and drive the fan directly as shown in Figure 5-3.6. Note the limited space in which to position the motor. This design was used because it had been seen on another cleaning machine with a hydraulically driven fan. Later, Professor Slocum noted that if a piece of debris were to become stuck in the rotating fan (at approximately 3600 rpm), large forces would be transferred to the shaft and bearings of the hydraulic motor. This presented a problem as the frame and hopper had not been designed to support a structure on which to mount a separate shaft support. In other words, the frame did not extend under the area below the fan shaft and part of the hopper was in the way. Several concepts were generated while trying to find a solution to the problem. The different concepts are shown in Figure 5-3.7.

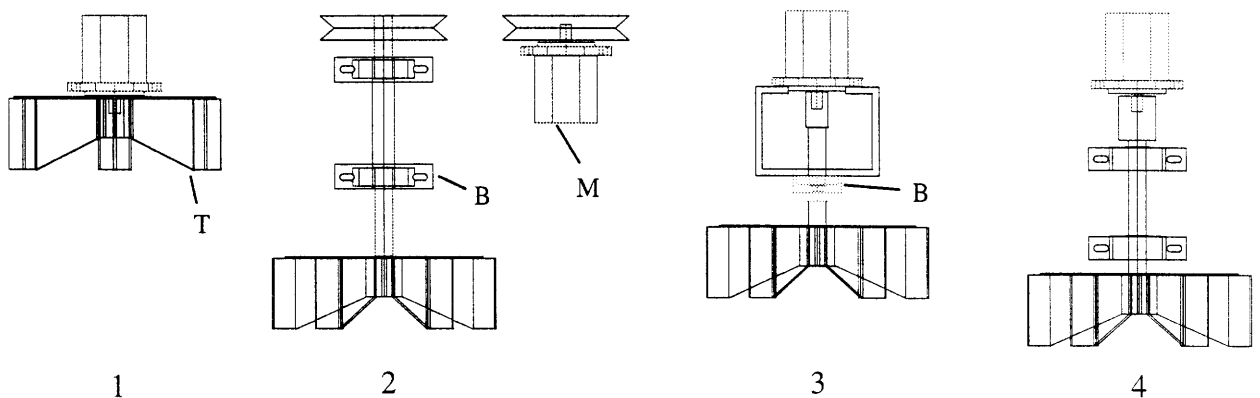

Figure 5-3. 7 Fan Drive Concepts

The letters in Figure 5-3.7 denote:

T - fan turbine

B - bearing or pillow block

M - hydraulic motor

Concept one was the original concept. In the second concept, the fan would be attached to a shaft and driven via a belt or chain at the opposite end. The third placed the fan on the end of a shaft which would run through a piece of steel tubing. A bearing would be attached to the steel tubing such that no load would be transferred to the motor bearings (because the pillow block located on the outside of the tubing was self aligning, it was later realized that this would allow the shaft to swivel and put a load on the hydraulic motor bearings). The fourth concept was similar, except it attached the shaft to a flat surface beneath itself.

Table 5-3. 2 Selection Matrix For Fan Motor Mounting				
1 = good, 3 = fair, 5 = poor				
	<u>% Weight</u>	<u>2</u>	<u>3</u>	<u>4</u>
Compactness of Design	25	3	1.5	2.5
Load Isolation	25	1	5	1
Machining Involved	20	3	2	3
Assembly	15	3	2	3
Number of Parts	15	4	3	2
Weighted Grade:	-----	2.7	2.8	2.3

Note that safety is not listed. This was because a guard could be mounted over moving parts in all of the designs, making each adequately safe. Although graded, concept three was automatically disqualified after it was realized that it would not protect the motor bearings. Of the two remaining concepts, the fourth looked best.

5.3.4.2 Fan Shaft Design

The material used to make the fan shaft was 4140 hardened (125 ksi) steel. This material was chosen because it is often used in axles and shafts. A similar material, 4340 steel, was considered, but was rejected because the author had seen problems machining this material in the past. The following variables appear in a fatigue analysis of the fan shaft.

DEFINITION OF VARIABLES

a	1.813	inches	, distance from front of blade assembly to point O
b	2.298	inches	, distance from point O to rear of blade assembly
c	0.500	inches	, minor shaft radius
d	1.000	inches	, minor shaft diameter
d _t	0.375	inches	, diameter of tapped hole in front of shaft
l _i	1.000	inches	, depth of threaded hole
e	5.125	inches	, distance between bearing centers
f	3.731	inches	, distance between front bearing and point O
g	4.375	inches	, length of front minor diameter section of shaft
h	3.750	inches	, length of major diameter section of shaft
i	2.425	inches	, length of rear minor diameter section of shaft
j	2.250	inches	, length of front keyway
k	1.000	inches	, length of rear keyway
D	1.125	inches	, major shaft diameter
r _{shoulder}	0.110	inches	, radius at shaft shoulders
r _{key}	0.050	inches	, radius at corners in shaft keyways
ω _{MAX}	3600	rpm	, maximum speed of fan blade assembly
m _{LUMP}	0.125	lbm	, mass of object caught in fan blade in front plane of blade assembly
r _{FAN}	6.200	inches	, radial distance from shaft center to position of mass
T _{MEAN}	228	in-lbf	, maximum constant torque
T _{ALT}	72	in-lbf	, maximum alternating torque, (with relief valve set at 3000 psi)

These variables are shown in the following three figures. A fatigue analysis is presented so that the reader may become familiar with the procedure. For components in later sections, this process will be left to the appendices.

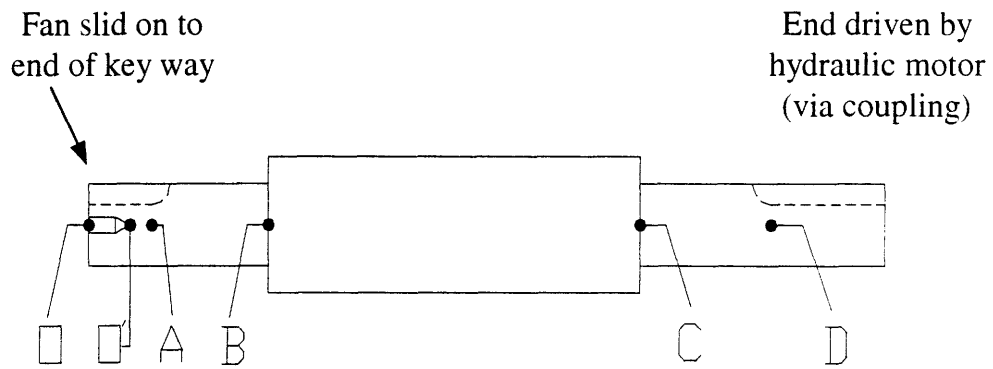

Figure 5-3. 8 Critical Fan Shaft Locations

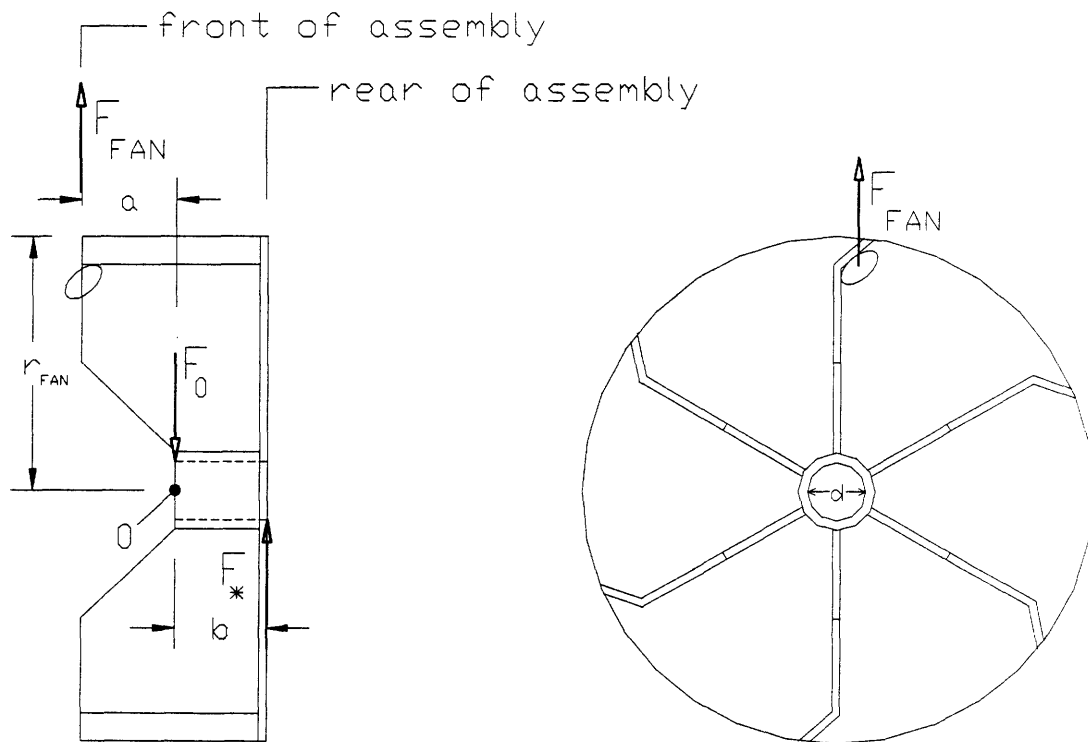

Figure 5-3. 9 Fan Blade Assembly

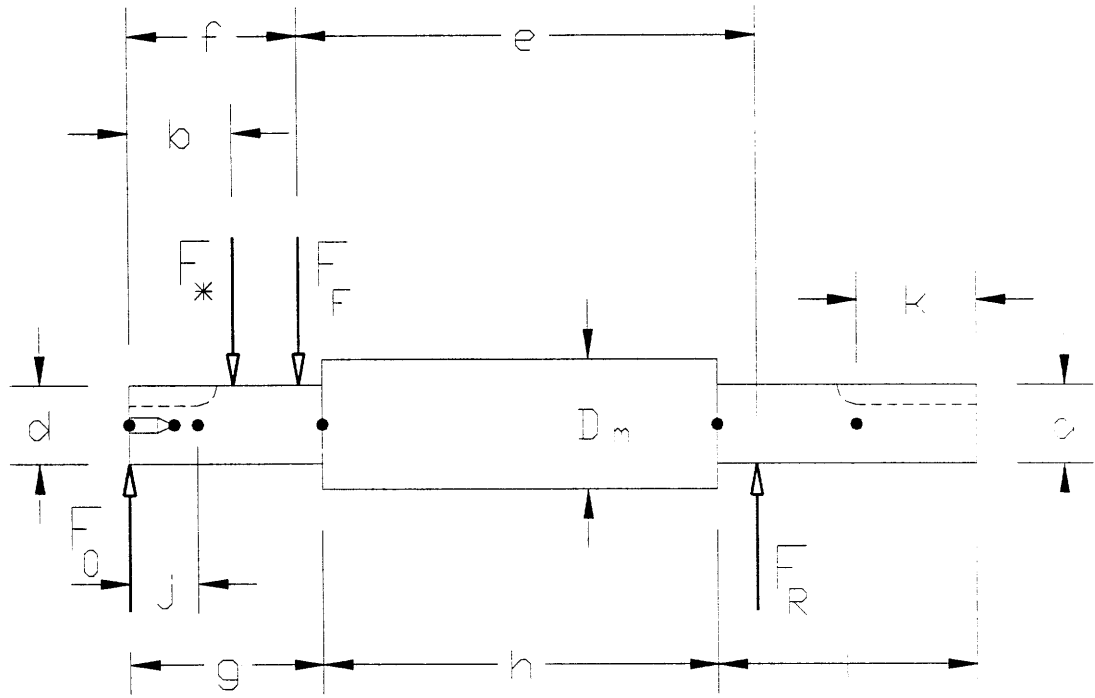

Figure 5-3. 10 Free Body Diagram of Fan Shaft and Dimensions

Force from lumped mass caught in front plane of fan blade assembly

$$F_{FAN} = m_{Lump} \text{lbm} \times \frac{r_{FAN}}{12} \text{ft} \times \frac{\text{lb} \cdot \text{s}^2}{32.2 \text{lbm} \cdot \text{ft}} \times \left[\left(\omega_{MAX} \frac{\text{rev}}{\text{min}} \right) \times \left(\frac{\text{min}}{60 \text{s}} \right) \times 2\pi \frac{\text{rad}}{\text{rev}} \right]^2$$

F_{FAN} 285.1 lbf ,force on fan blade assembly from lumped mass

Fan Blade Assembly Equilibrium Equations and Force Solutions

$$\sum F_Y = 0 = F_{FAN} + F_* - F_O$$

$$\sum M_O = F_{FAN} \times (a) - F_* \times b = 0$$

$$F_* = F_{FAN} \times \left(\frac{a}{b}\right)$$

$$F_O = F_{FAN} + F_* = F_{FAN} + F_{FAN} \times \left(\frac{a}{b}\right)$$

$F_* = 224.9 \text{ lbf}$,force on rear of blade assembly

$F_O = 509.9 \text{ lbf}$,force on front of blade assembly

Fan Shaft Equilibrium Equations and Force Solutions

$$\sum F_Y = F_O + F_R - F_* - F_F = 0$$

$$\sum M_O = -F_* \times (b) - F_F \times (f) + F_R \times (f + e) = 0$$

$$F_R = \frac{F_* \left(1 - \frac{b}{f}\right) - F_O}{\left(1 - \frac{f + e}{f}\right)}$$

$$F_F = \frac{(F_R \times (f + e) - F_* \times (b))}{f}$$

$F_R = 308.3 \text{ lbf}$,force on rear bearing

$F_F = 593.4 \text{ lbf}$,force on front bearing

summation check, $\sum F_y = 0 ?$	0.0
-----------------------------------	-----

Note, position described by variable x, is distance from point O along shaft.

Shear, Moment, and Stress Data

x inch	V lbf	M _a lbf-in	d inch	Alternating Bending Stress, σ_a psi	Constant Shear Stress, τ psi	Alternating Shear Stress, τ_a psi	Constant Von Mises Stress σ_{mVM} , psi	Alternating Von Mises Stress σ_{mVM} , psi
0.000	0	0	1.000	0	1185	374	2052	648
0.000	510	0	1.000	0	1185	374	2052	648
1.000	510	510	1.000	5194	1185	374	2052	5234
1.000	510	510	1.000	5194	1161	367	2011	5233
2.250	510	1147	1.000	11687	1161	367	2011	11704
2.298	510	1172	1.000	11934	1161	367	2011	11950
2.298	285	1172	1.000	11934	1161	367	2011	11950
3.731	285	1580	1.000	16096	1161	367	2011	16108
3.731	-308	1580	1.000	16096	1161	367	2011	16108
4.375	-308	1382	1.000	14073	1161	367	2011	14088
4.375	-308	1382	1.125	9884	816	258	1413	9894
8.125	-308	225	1.125	1612	816	258	1413	1673
8.125	-308	225	1	2296	1161	367	2011	2382
8.856	-308	0	1	0	1161	367	2011	635
8.856	0	0	1	0	1161	367	2011	635
9.550	0	0	1	0	1161	367	2011	635
10.550	0	0	1	0	1161	367	2011	635
10.550	0	0	1	0	1161	367	2011	635

Fatigue Factor of Safety Calculation

The following method of calculating fatigue factor of safety was taken from Mechanical Engineering Design, by Shigley and Mischke, 5th edition. All page numbers in the analysis refer to pages in the above mentioned text.

Ultimate Strength, S_{ut}

Given 4140 steel heat treated, $S_{ut} = 125$ kpsi minimum and $S_y = 105$ kpsi minimum.

Note: Values quoted from Matt McDonald Steel Company

$$S_{ut} = 125 \text{ kpsi}$$

Test specimen endurance limit, S_e'

$$S_e' = 0.504 S_{ut}$$

$$S_e' = 63 \text{ kpsi}$$

Marin factor for surface finish, K_a

$$K_a = a' S_{ut}^{b'}$$

see p. 282

for ground surfaces:

$$a' = 1.34$$

and

$$b' = -0.085$$

$$K_a = 0.89$$

Marin factor for size, K_b

$$K_b = 0.872 d^{-0.1133}$$

see p. 283

$$K_b = 0.87$$

Marin factor for load, K_c

$$K_c = 1.00$$

see p.284

Endurance limit, S_e

$$S_e = K_a K_b K_c S_e'$$

$$S_e = 48.8 \text{ kpsi}$$

see p. 282

Stress concentration factors, K_t

Note: r/d and d/D are required ratios to find K_t from table A-15

K_{tA}	,shear stress concentration at point A
$K_{t\sigma A}$,normal stress concentration at point A
K_{tB}	,shear stress concentration at point B
$K_{t\sigma B}$,normal stress concentration at point B
K_{tC}	,shear stress concentration at point C
$K_{t\sigma C}$,normal stress concentration at point C
K_{tD}	,shear stress concentration at point D
$K_{t\sigma D}$,normal stress concentration at point D
q_τ	,torsional notch sensitivity
q_σ	,tensile/bending notch sensitivity

$K_{t\sigma}$ from Figure A-15-9, p. 748

$K_{t\tau}$ from Figure A-15-8, p. 748

q_σ from Figure 5-16, p. 218

q_τ from Figure 5-17, p. 218

Fatigue Factor of Safety

Point	Stress Factors		Notch Sensitivities		Modified Stress Factors		Von Mises Stress Multiplied by Kf		Factor of Safety η_f
	$K_{t\sigma}$	$K_{t\tau}$	q_σ	q_τ	$K_{f\sigma}$	$K_{f\tau}$	$\sigma_{\mu VM}$ psi	$\sigma_{\alpha VM}$ psi	
O	2.50	2.26	0.813	0.962	2.22	2.21	2052	1411	22.1
O'	2.50	2.26	0.813	0.962	2.22	2.21	2052	11616	3.9
A	2.50	1.00	0.813	0.962	2.22	1.00	2011	25950	1.8
B	1.58	1.30	0.866	0.983	1.50	1.29	1413	21154	2.2
C	1.58	1.30	0.866	0.983	1.50	1.29	1413	3545	11.9
D	2.50	1.00	0.813	0.962	2.22	1.00	2011	635	34.4

The lowest factor of safety, with respect to fatigue, was at the root of the fan side key way (point A). This was satisfactory for the short life of the prototype. For the production model, a factor of safety above 5 would be desired.

5.3.5 Auger Drive

A hydraulic motor was to run the auger via a chain or belt. Figure 5-3.11 shows the basic layout. Specifics on how the auger was mounted and the shape of the hopper are covered in

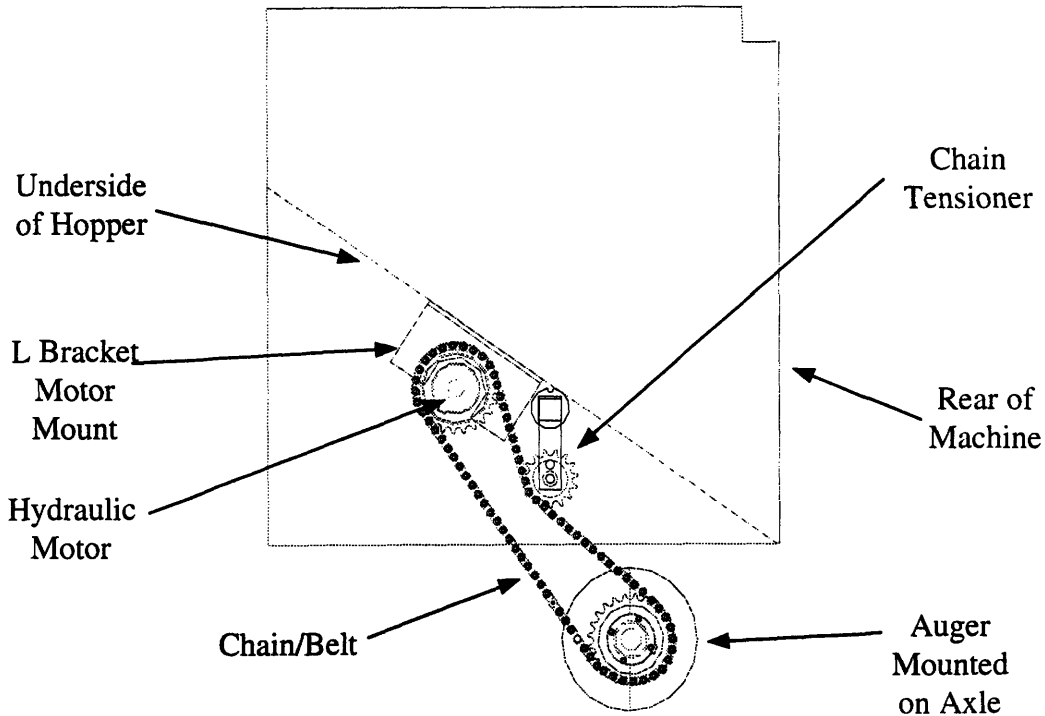

Figure 5-3. 11 Side View of Auger Drive

sections 5.4 and 5.5 respectively. Note that the hydraulic motor was mounted under the lower edge of the hopper to save space. Also, a chain tensioner was used to keep the chain tight. In a production model, the chain would be replaced by a belt to decrease maintenance.

5.4 Axle and Suspension

Figure 5-4.1 shows a simplified model of the assemblies of interest. Concepts for the axle, suspension system, and auger mounting will be considered independently. We start first with the axle and bearing design.

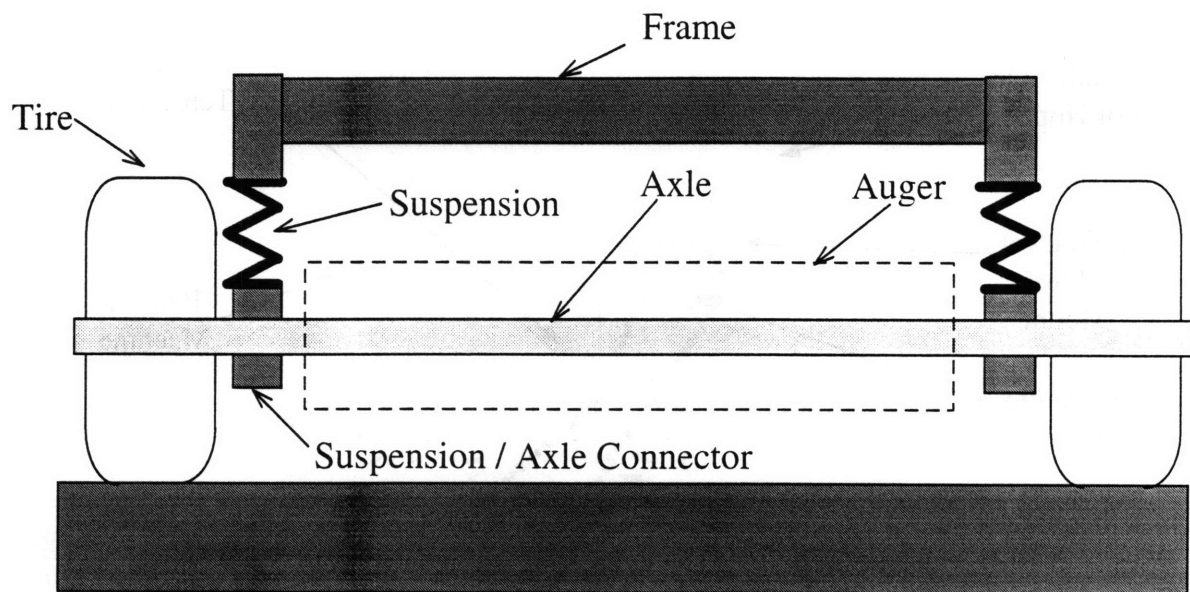

Figure 5-4. 1 Simple Suspension System

5.4.1 Axle and Bearing Concepts

5.4.1.1 First Axle and Bearing Concept

The axle was most complex where it connected to the wheels and frame. In between, the axle would have a constant diameter and is of little interest. The first axle concept is shown in

Figure 5-4.2. This concept was essentially the same design as found in many automobiles. This design used a tapered bearing set to permit rolling motion between the axle and wheel assembly. Although two tapered bearings are shown, a design using one tapered roller could be used. The

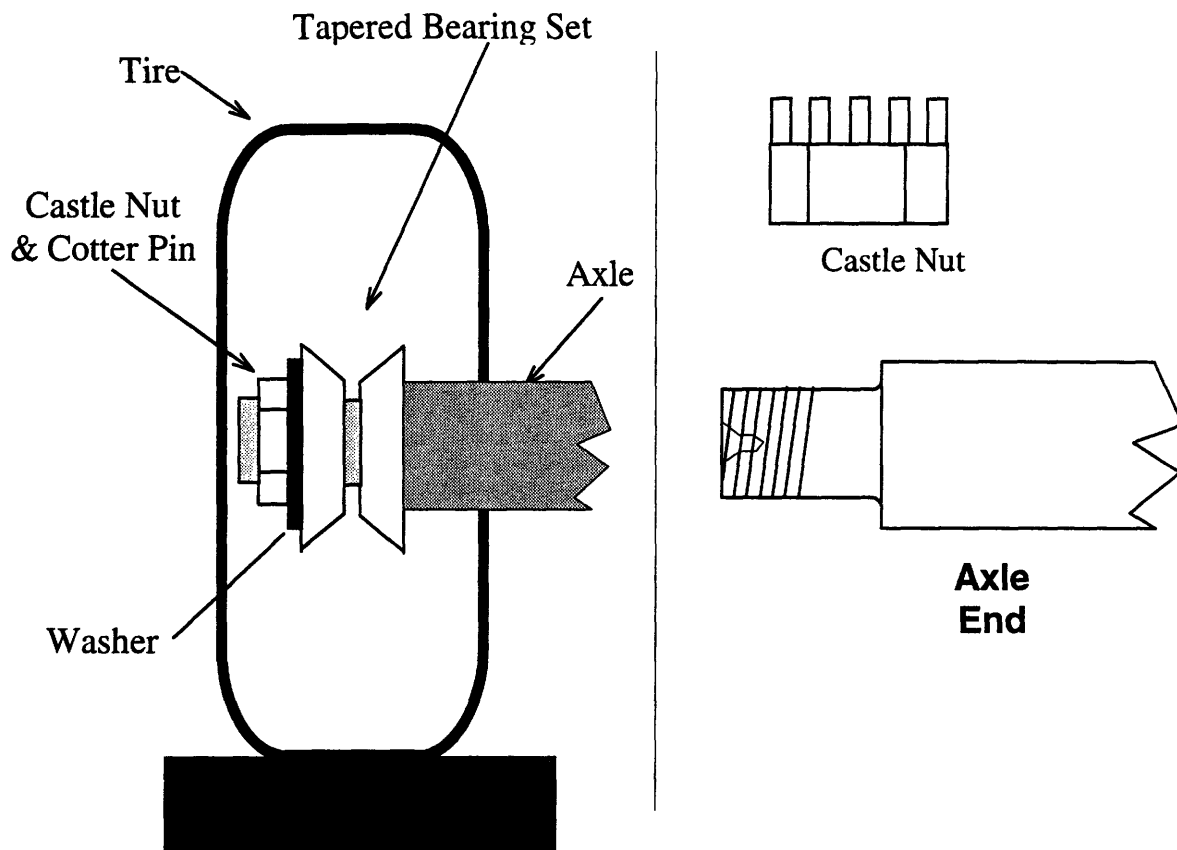

Figure 5-4. 2 First Axle End Concept

bearings and wheel assembly are held together by a castle nut (see Figure 5-4.2 for example of nut). One of the slots in the tightened castle nut would be aligned with a hole in the axle. A cotter pin would be run through the hole and axle, then bent over the opposite side of the nut to prevent the nut from loosening and changing the bearing settings. This design was robust, but very expensive. The prime contributors to the design's cost were the expensive tapered bearings and the process of threading and drilling the shaft end.

5.4.1.2 Second Axle and Bearing Concept

In the second concept, a straight axle (perhaps non-machined) would be slid into a wheel hub, then the ends of the axle deformed to the shape shown in Figure 5-4.3. The bulge at the end

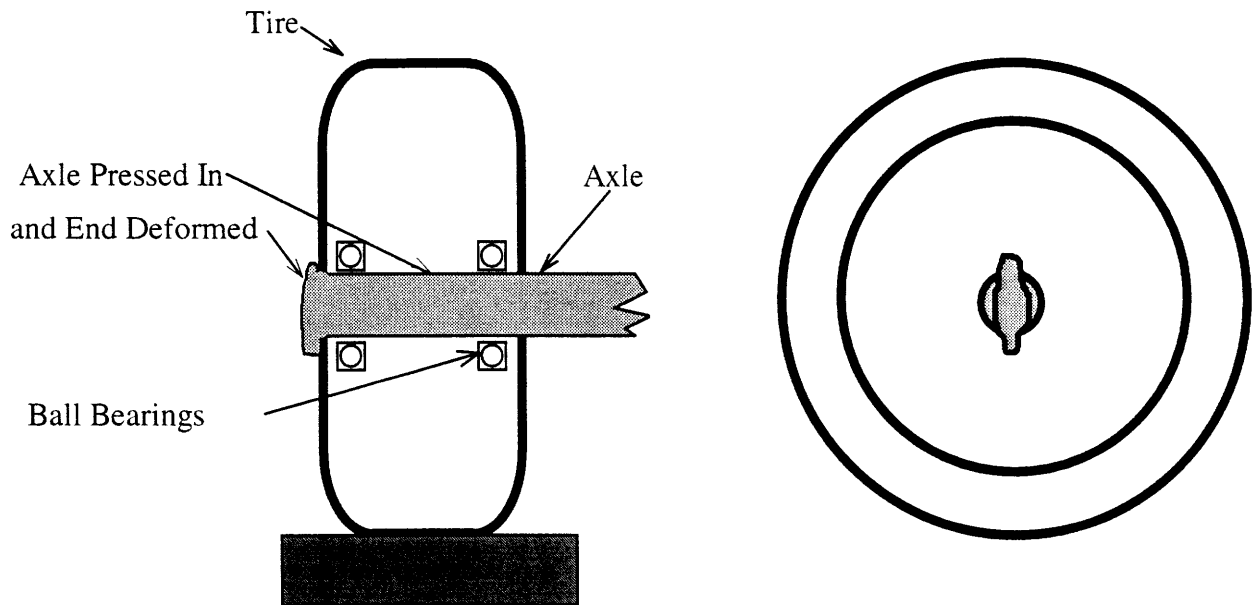

Figure 5-4. 3 Second Axle End Concept

of the axle would prevent the wheel assembly from sliding off. The reader should note that this is a design used on children's toy wagons and many low load carts.

This concept was attractive because it avoided using expensive fasteners to hold the wheel assembly. Also, this design was less costly than the first because it used low-cost, sealed ball bearings as opposed to more expensive tapered rollers. As the bearings were contained within the hub, assembly of the of the axle and wheels could be done faster (with respect to the first concept).

Typically, ball bearings are not designed for axial loading. Originally it was thought that this could be a problem when the machine was turning a corner. However, wheel assemblies

(with sealed ball bearings) were found which, by design, isolated the bearings from axial loading. The concept is illustrated in Figure 5-4.4. Some axial and radial motion between the inner bearing race and axle was permitted. When the wheel would be loaded parallel to the axle, force would be transmitted from tire to hub, axle, then to machine. Note that the ball bearings are not in the force loop.

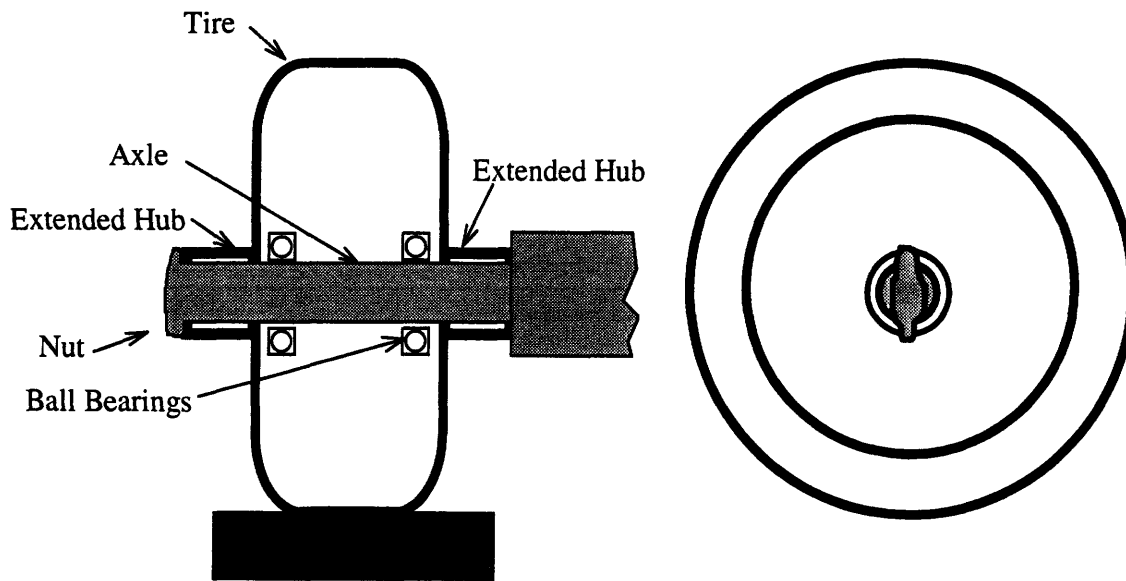

Figure 5-4. 4 Modification of Second Axle End Concept

This design would be less costly than the first, however, it had one major drawback. After repeated loading, the end of the axle would deform from its original shape. When this happened, the fit between the wheel hub and the clamping portions of the axle would degrade, making it possible for the wheel to rattle and make noise.

5.4.1.3 Third Axle and Bearing Concept

The third concept was a combination of the most desirable characteristics of the first two. The design, shown in Figure 5-4.5 used the castle nut/cotter pin from the first concept and a wheel with extended hub and sealed ball bearings from the second concept. The combination of these characteristics yielded a design which was between the first and second in terms of cost and durability.

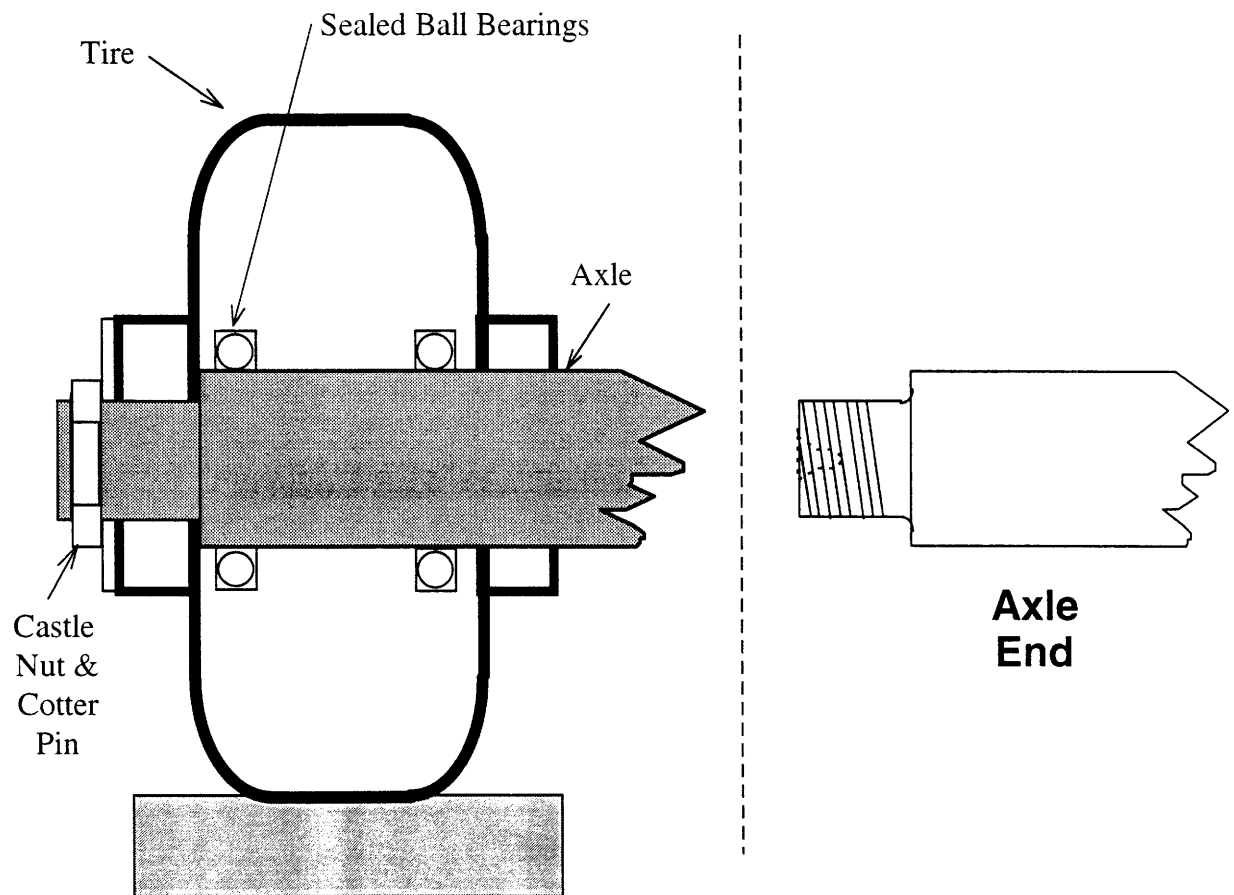

Figure 5-4. 5 Third Axle End Concept

5.4.1.4 Final Axle and Bearing Concept

During the design process, the author matched desirable components from the first two components to make a better design. A selection matrix was not used to pick a final design as the third design had all of the desired characteristics. Specifically, the first concept was too expensive, and the author was concerned about the durability of the second.

5.4.2 Suspension System Concepts

5.4.2.1 First Suspension System Concept

The first concept is shown in Figure 5-4.6. This type of assembly was considered because it was a proven design used widely on boat trailers and automobiles.

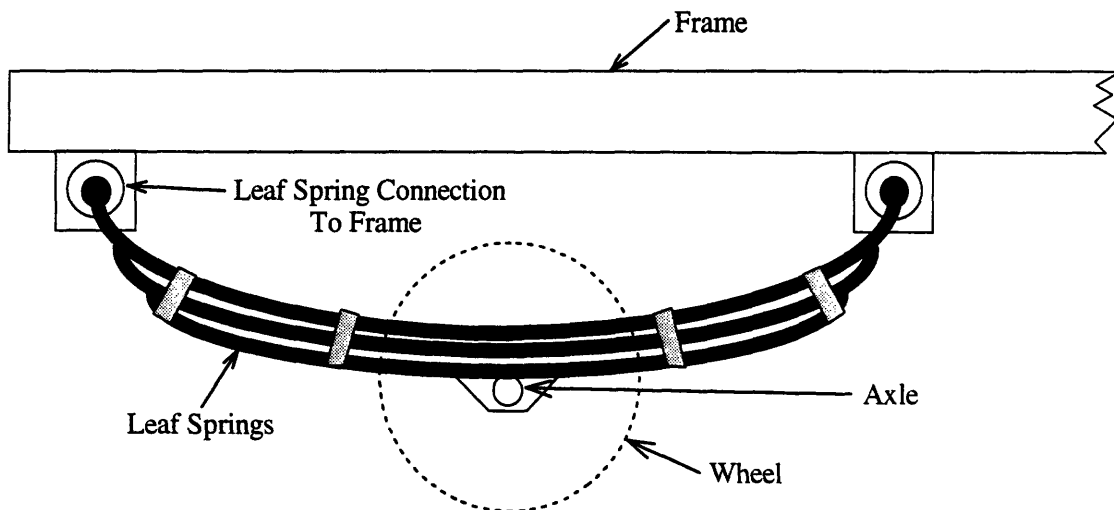

Figure 5-4. 6 First Suspension System Concept

5.4.2.2 Second Suspension System Concept

Instead of using leaf springs, this design used a thick compliant rubber pad of low durometer (hardness). The pad and axle connector dimensions into the paper were chosen such that the design would resist tilting of the axle connectors when loaded axially. This design was considered because rubber would be inexpensive and could be molded to the required shape.

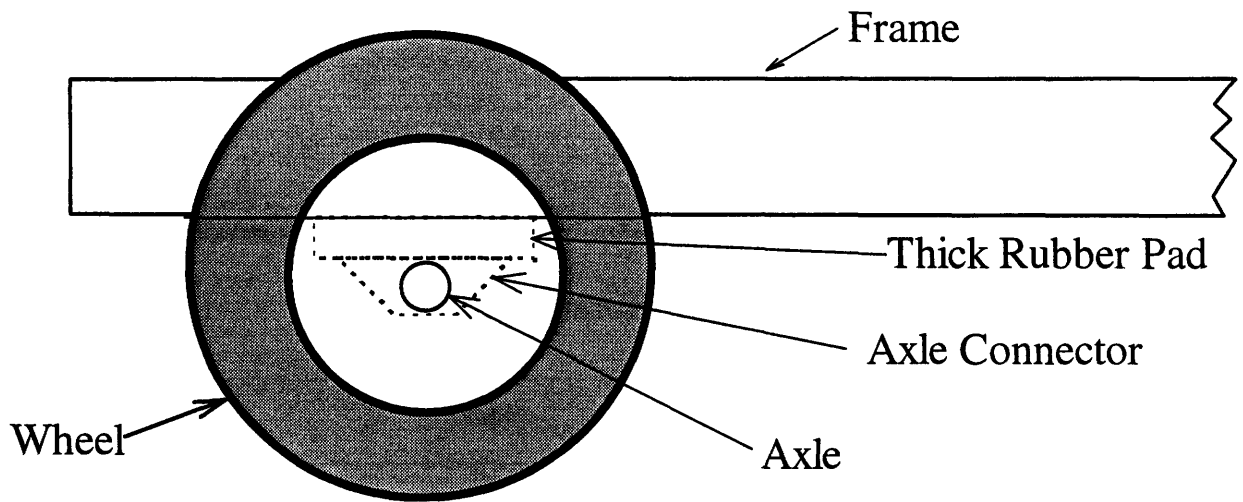

Figure 5-4. 7 Second Suspension System Concept

5.4.2.3 Third Suspension System Concept

The last concept, shown in Figure 5-4.8, differed from the previous in the absence of the thick rubber pad. In this case, the axle connector would be mounted directly to the frame. In the absence of shock absorbing components, cost of the design would be decreased.

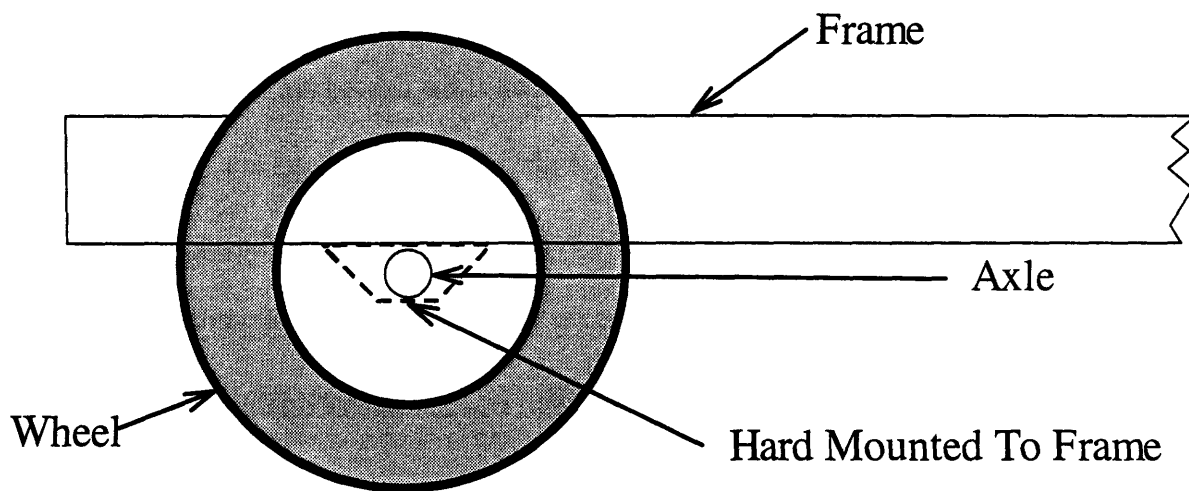

Figure 5-4. 8 Third Suspension System Concept

5.4.2.4 Final Suspension System Design

The compliance of a leaf spring suspension was not needed in this application. First there were no components on the machine to which a bumpy ride would be detrimental. Second, it will be recommended that the debris cleaner not be towed in excess of 10 mph. Although there may be some impact loads transmitted to the tires when towed at this speed, the use of the second or third concept in conjunction with pneumatic tires should provide a sufficient cushion.

The second (thick rubber pad) and third concept (hard mount) could be used as just described. However, in comparing the two, there would be little difference in performance. This was so because the rubber pads of the second option would be compressed by the weight of the

machine to a point where its compliance would become negligible compared to that of the hard mount option. As such, the hard mount option was used in the prototype.

5.4.3 Auger Mounting Concepts*

The auger was to be mounted on an axis substantially parallel to that of a supporting axle. Doing this would ensure that the distance from the center of the axis to the ground would be independent of machine orientation. For example, if the auger were placed at a substantial distance in front of the axle, a forward pitch in the machine could result in the auger digging into the ground. Placing the auger on the same axis as the axle ensures essentially constant distance from the ground. The only vulnerability of this design was that the auger could dig into high spots which fit in-between the tires.

* Originally, the auger was to be mounted as in the first concept. Later, bearing misalignment problems with the original design made it necessary to generate additional designs.

5.4.3.1 First Auger Mounting Concept

The first mounting concept came from a snow blower design. In this design, two ball bearings were pressed into a housing in the ends of the auger. The design for the prototype, shown in Figure 5-4.9, would be similar. However, under the actual weight of the machine, the deflection of the axle would be such that provision for axle deflection would be required. Also,

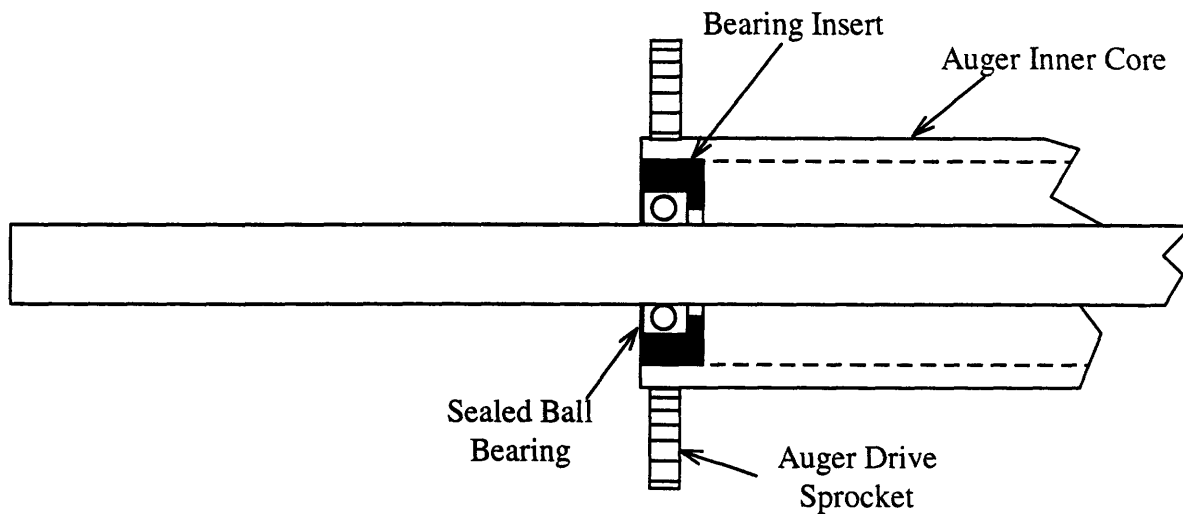

Figure 5-4. 9 First Auger Mounting Concept

the pipe used for the auger core would not be perfectly straight. This would add to the misalignment between the bearings in the two ends.

5.4.3.2 Second Auger Mounting Concept

The second concept, shown in Figure 5-4.10, was proposed by Professor Slocum. In this arrangement, the bearing insert would be made such that there was a small gap (0.001 - 0.002 inches) between the outer diameter of the ball bearing and the inner diameter of the bearing insert. Professor Slocum suggested this design because the gap would allow for some

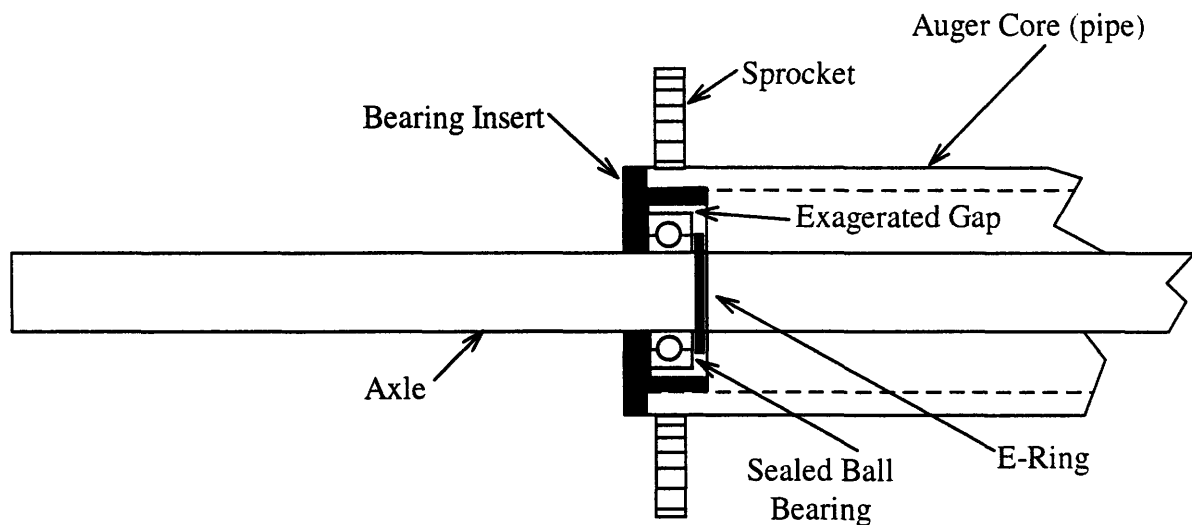

Figure 5-4. 10 Second Auger Mounting Concept

misalignment between the auger core and axle. He also noted that it could be made at little cost if the bearing inserts were cast. Later however, in conversations with Professor Slocum, the loose fit of the bearings became a concern because the rattling bearings would make noise and could have subjected the bearing to impact loads.

5.4.3.3 Third Auger Mounting Concept

The third concept was the same as the second, except for a thick strip of low durometer rubber which lined the inside of the bearing insert. The bearing would be placed in the lined insert with a loose fit, then the assembly bolted to the end of the auger insert. As the rubber would not permit free motion (rattling) of the bearing, noise and impact loading would be reduced. Later, after the grading of the concepts, it was realized that the snap rings in this design would load the ball bearings axially.

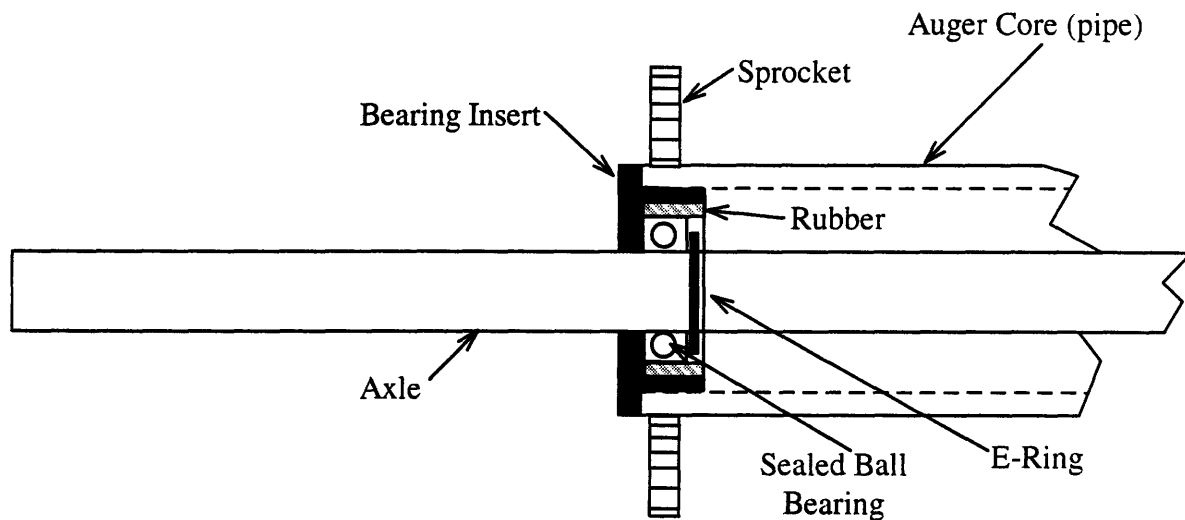

Figure 5-4. 11 Third Auger Mounting Concept

5.4.3.4 Fourth Auger Mounting Concept

The fourth concept, seen in Figure 5-4.12 would use either a spherical roller or internally aligning ball bearing. The bearing would fit snugly inside of the bearing insert with seals on each

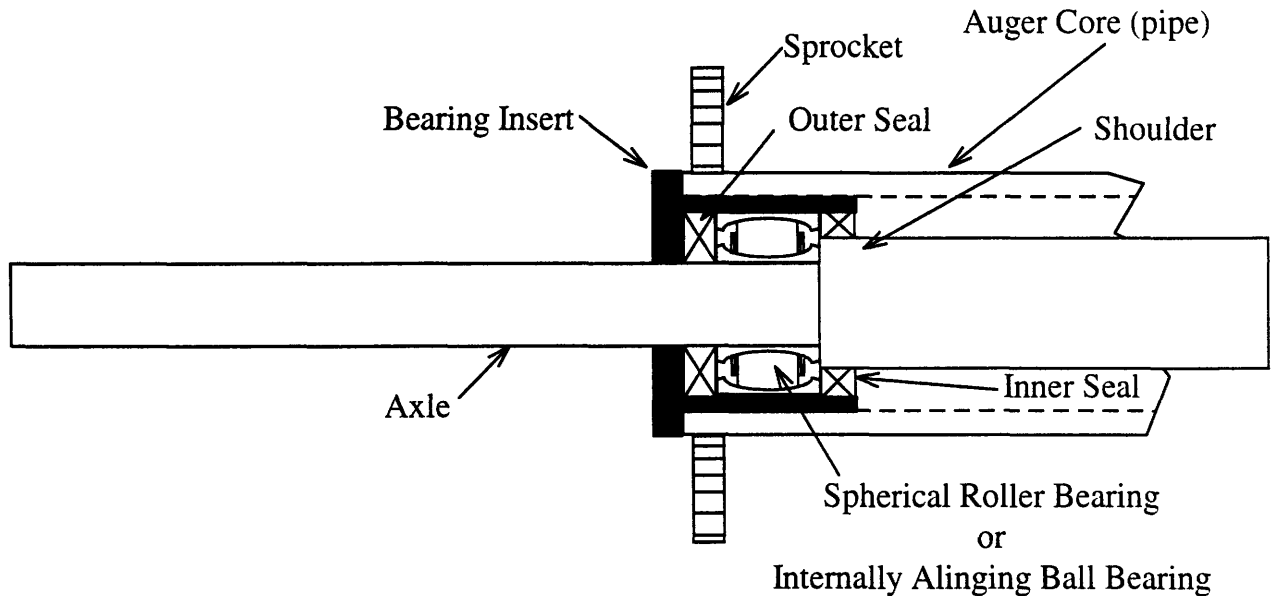

Figure 5-4. 12 Fourth Auger Mounting Concept

side and be held in place by means of a snap ring, shaft shoulder, or some other method. This design would be more able to handle axial loads and shaft misalignment. However, the cost of this design was much greater than any of the previous. A sealed ball bearing could be purchased for approximately \$15.00. In comparison, a spherical roller, grease, and two seals cost approximately \$50.00. Cost would also be added in drilling and tapping two holes (one for each bearing) for lubrication ports.

5.4.3.5 Final Auger Mounting Concept

The third design will be used in the prototype. The decision to use this design was based on three criteria: functionality, cost, and difficulty of assembly. Grades for each criteria were

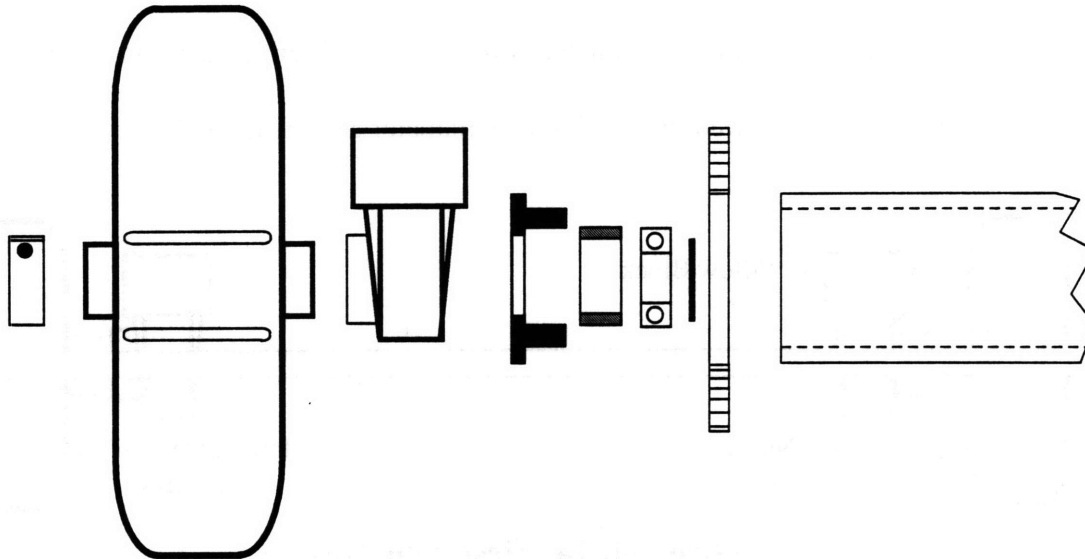

Figure 5-4. 13 Exploded View of Final Design

given, then adjusted by weights which signify their importance to the design. Individual grades can be seen in Table 5-4.1.

Table 5-4. 1 Selection Matrix for Auger Mounting Concept					
1 = good, 3 = fair, 5 = poor					
Criteria	Concept 1	Concept 2	Concept 3	Concept 4	Weight
Functionality	4.5	4	2.5	1	40%
Cost	2	2	2.5	4	35%
Assembly	3.5	2.5	3.0	4	25%
Weighted Grade	3.4	3.0	2.6	2.8	

5.4.4 Development of Axle/Suspension System/ Auger Mounting Assembly

5.4.4.1 First Stage of Axle/Suspension/Auger Mount Development

The first design used a straight axle made to fit the auger of a snow blower. The bearings provided with the auger had an inner diameter of 0.75 inches. Preliminary calculations done via the “back of an envelope” showed that a 0.75 inch diameter axle made of 4140 hardened steel

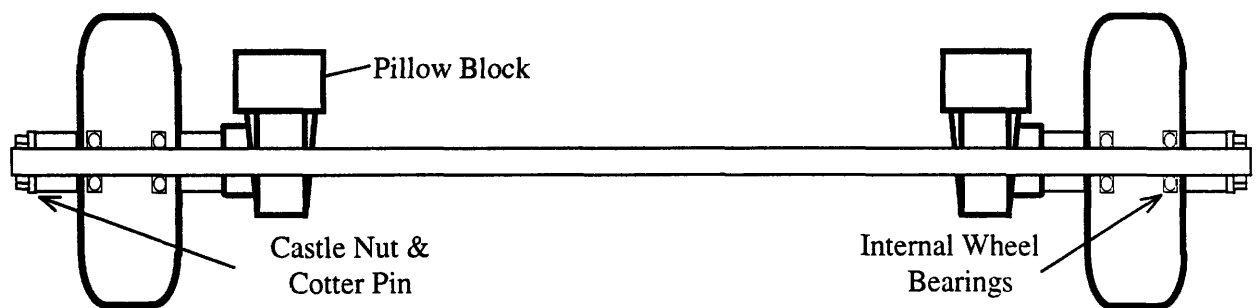

Figure 5-4. 14 First Axle Design

would be sufficient for the induced stress. This type of steel was chosen as it was recommended as an axle material by the Metals Handbook and personnel at Matt McDonald Steel Supply. The author had also seen it used to make shafts at the plant of a previous employer.

Referring to Figure 5-4.14, the axle would be connected to the frame via self aligning pillow blocks. One might argue, as in section 5.4.1.2, that the use of ball bearings in components used to mount the axle may be inappropriate because of axial loading. Ideally, some sort of self aligning mount, possibly a self aligning bushing, would be used to hold the axle. For the prototype however, a self aligning pillow block would suffice. Whether or not the pillow blocks could handle axial loading was of no consequence. The bearings in the wheels, not the bearings in the pillow blocks, would permit the rotary motion of the wheels.

5.4.4.2 Second Stage of Axle/Suspension/Auger Mount Development

The second axle used the same mounting concept, but with a "beefed up" middle portion as shown in Figure 5-4.15. The ends of the axle were kept at 0.75 inches so that the original

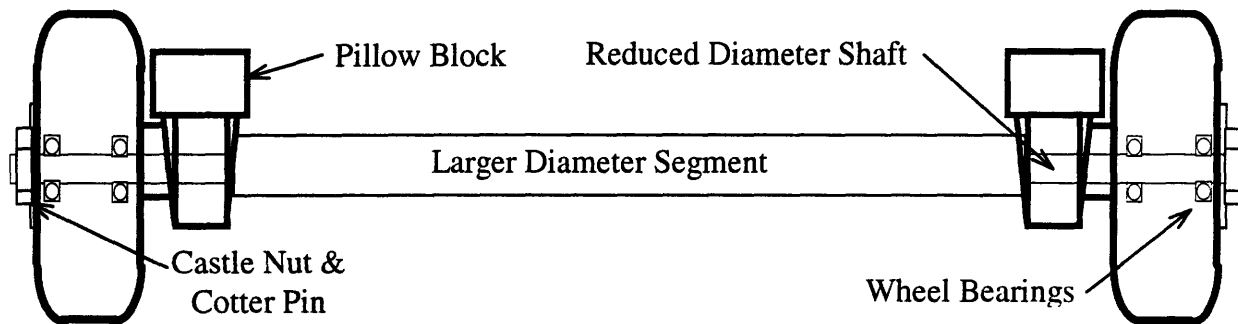

Figure 5-4. 15 Second Axle Design

pillow blocks could be used. However, the finished machine came to weigh approximately 50% more than anticipated. This was due to the underestimated weights of the engine, frame, hydraulic tank, hopper, and other components. The increased weight presented two problems. First, the fatigue factor of safety would be substantially less than one. Second, the weight supported by the wheels would be over the rating of the wheel bearings. The solution to the problem was to redesign once more.

5.4.4.3 Final Stage of Axle/Suspension/Auger Mount Development

The axle was designed straight (to eliminate the stress concentration of the shoulder) and larger in diameter (increased to 1.00 inches). Also, wheels selected for the larger diameter axle had roller bearings for more load capacity. The mounting and other general configurations of

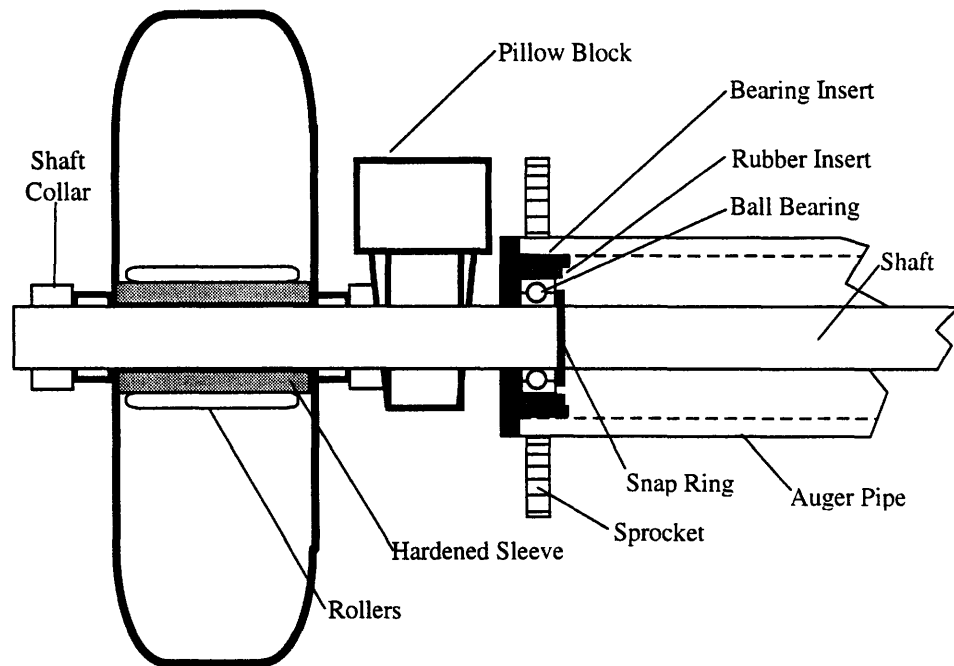

Figure 5-4. 16 Third Axle Design

this subsystem were the same as in the first two iterations. Stress and deflection calculations for this design are similar to those in section 5.3. Details can be found in Appendix F.

5.5 Hopper

5.5.1 Concepts For Hopper Shape

The different concepts for hopper shapes were evaluated using four criteria: compactness of design, cost, complexity, and customer needs. The first three criteria are self explanatory. The fourth included hopper volume and method of hopper purge. Conversations with dealers of lawn and garden equipment showed that a self emptying hopper was something that customers look for. Hopper volume was an issue because hoppers with low capacity must be emptied more often. Dealers said this would be a deciding factor for customers with large lawns.

5.5.1.1 First Hopper Shape Concept

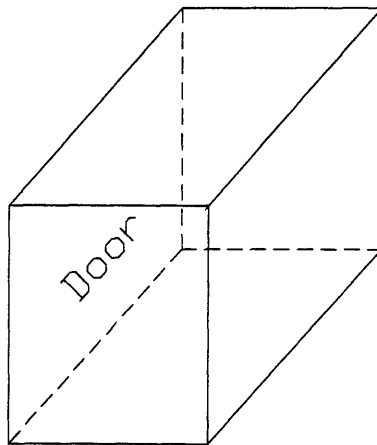

Figure 5-5. 1 First Hopper Concept

The first concept, shown in Figure 5-5.1, was a "box like" structure. This shape was considered because it was simple and had a large capacity (in comparison to the following concepts). However, using this design would make it difficult to have a compact design. More

clearly, if this design were used, components of the machine such as the engine and fan would have to be placed to either the front, back, or side of the hopper. A larger frame would be required to support this equipment. This was undesirable as pull-behind vehicles with larger frames cannot turn with as sharp a radius as those with smaller frames. This becomes an issue when one reaches the edge of a lawn and must turn 180 degrees to re-enter the debris field. Too large a turning radius will result in a gap between the new and cleaned paths.

Another drawback to this design was that this hopper was not self cleaning (self emptying). Dealers of lawn and garden equipment said this would have a negative impact upon a customer's decision to buy.

5.5.1.2 Second Hopper Shape Concept

The second concept was similar to the first, but varied in that a corner was "cut out of" the box. This would provide a place to mount components of the machine so that a more compact assembly was possible. Another benefit was that the hopper would be partially self

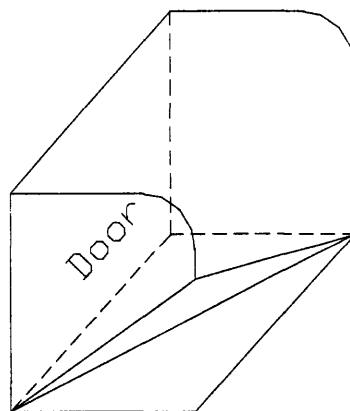

Figure 5-5. 2 Second Hopper Concept

emptying. However, dealers of lawn and garden equipment noted that this design would not sell well because it was not completely self emptying.

5.5.1.3 Third Hopper Shape Concept

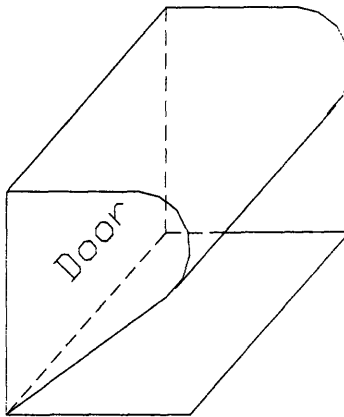

Figure 5-5. 3 Third Hopper Concept

The structure of the third concept was shaped like a half heart. This design was completely self emptying, provided the angle of the slanted edge was large enough. Upon opening of the door, the debris would slide onto either the ground or some collection device. In this design, there was space below the angled edge of the hopper for mounting of other components. One drawback was that the capacity of this hopper, as compared to those of concepts one and two, was smaller. This was undesirable because a hopper with low capacity must be emptied more frequently. However, since the volume of the debris was to be significantly reduced when shred by the fan, hopper volume was not critical in the choice of a design.

5.5.1.4 Final Hopper Design

The difference in complexity of designs was minor. In terms of cost, the biggest difference would come from material cost. As the third concept allowed for the most compact design, less material would be needed to support the various components of the machine. Also, for approximately the same machine size, the surface area of the third design was lower. This meant that less material would be needed to form the walls of the hopper.

The third concept was clearly the best and was chosen without using a selection matrix. The reader should note that the same design was used by other debris cleaners.

5.5.2 Concepts For Hopper Frame

Initially, the hopper was to be constructed using a traditional frame. However, Professor Slocum proposed another idea which was easier to manufacture.

5.5.2.1 First Hopper Frame Concept

A traditional frame is shown in Figure 5-5.4. In this design, sheet metal or fiberglass panels would be joined to the frame to form the enclosure. This design was used by most debris cleaners, but had two drawbacks. First, labor costs were very high. One would have to hire one

or two experienced welders* (roughly \$15 an hour per person) to build the frame. Also, one person and equipment would be needed to cut and debur the frame members prior to welding. Second, making the frame would take a considerable amount of time. In the frame shown in Figure 5-5.4, there are roughly 20 joints. Total welding time, assuming 1 minute per continuous weld, would be 20 minutes. In order to keep this stage of the process from becoming a "bottle

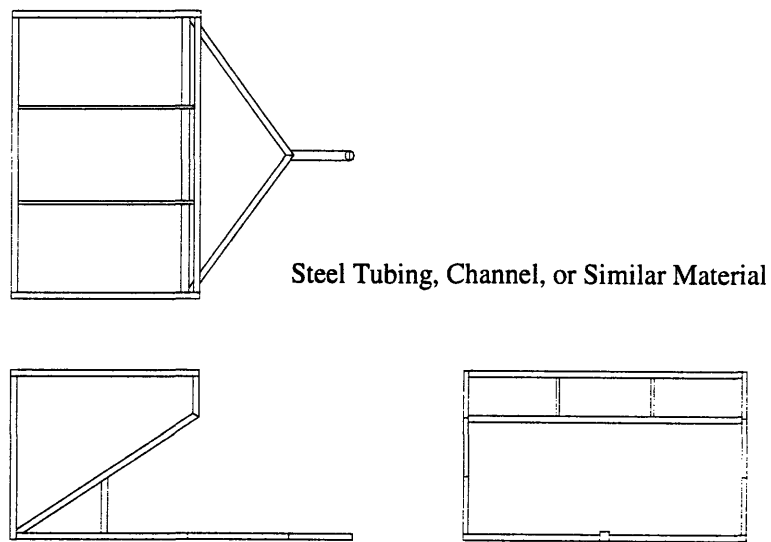

Figure 5-5. 4 First Hopper Frame Concept

neck", several stations with one or two welders, or complicated machinery and fixturing would be needed.

* Estimations done with help Metal Smiths Incorporated, a sheet metal fabricator.

5.5.2.2 Second Hopper Frame Concept

The second concept used a hopper made from folded pieces of sheet metal. As shown in Figure 5-.5, the edges of the body and side panels would be folded so that once slid over and

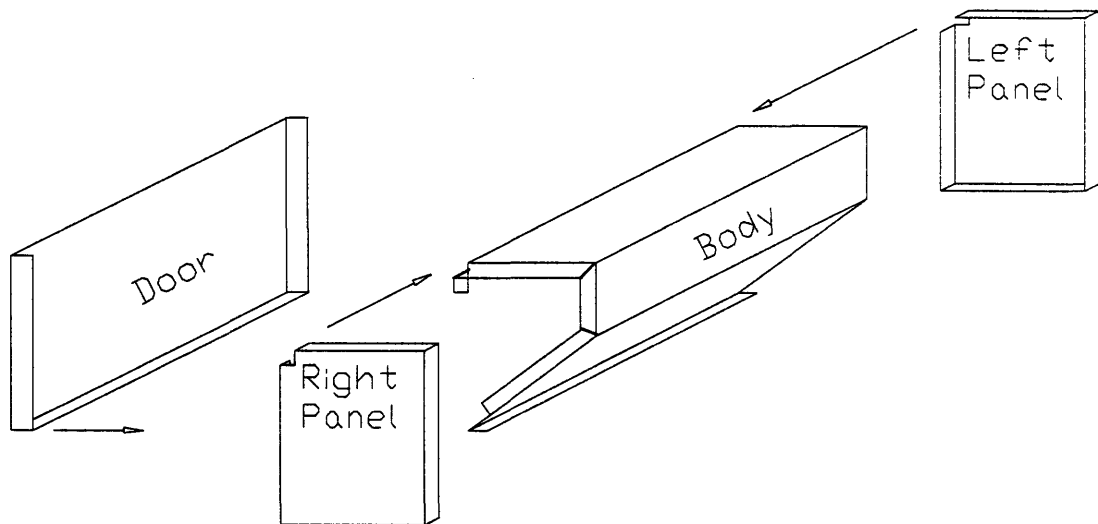

Figure 5-5. 5 Second Hopper Frame Concept

welded to the body, they would essentially form a rigid angle frame. To enclose the hopper's contents, a door would slide over the rear of the hopper and be held in place by a continuous hinge connected to the ridge at the rear of the hopper body.

This design would be easier to manufacture than the traditional frame. First, if all pieces of the hopper were available, they could be assembled and welded together in approximately 15 minutes. Welding would be easier as the folded edges of the components lie flush at their contacting surfaces. Lap joints such as these would be much easier to weld than the "T" joints one would have to weld in a traditional frame. Also, in a traditional frame, continuous welds

would be required to seal the enclosure. The hopper of concept two was self sealing, thereby allowing faster stitch welding to be used.

Also, if a traditional steel frame and sheet metal were used, there would be an additional painting or other corrosion preventing process the frame must go through before having the sides attached. For the hopper in concept two, this would not be required. All surfaces (interior and exterior) of the hopper could be painted in one process.

In addition, fabrication of the pieces would be easy and inexpensive. After consultation with Metals Smiths Incorporated, it was decided that the best way to manufacture the blanks for the hopper would be to have a laser shop cut the patterns from steel sheet. Laser shops, such as Creative Processing, charge between \$120 and \$150 dollars per hour for cutting (on the high end). A 3000 kW laser (common for shops to have) should be able to cut each pattern in less than 2 minutes. Figuring four patterns per hopper, at roughly \$150 per hour, this comes to \$20 dollars per hopper. Also, the tooling required to bend the patterns to shape was simple, inexpensive, and durable.

5.5.2.3 Final Hopper Design

Concept two, shown fully assembled in Figure 5-5.6, was chosen for the prototype design. At first, blow molded fiberglass was considered as an alternative to steel, but was rejected because it degrades in sunlight. Richard Slocum, brother of Professor Slocum noted that weakened side panels might blow under pressure from the fan, throwing sharp pieces of fiberglass outward.

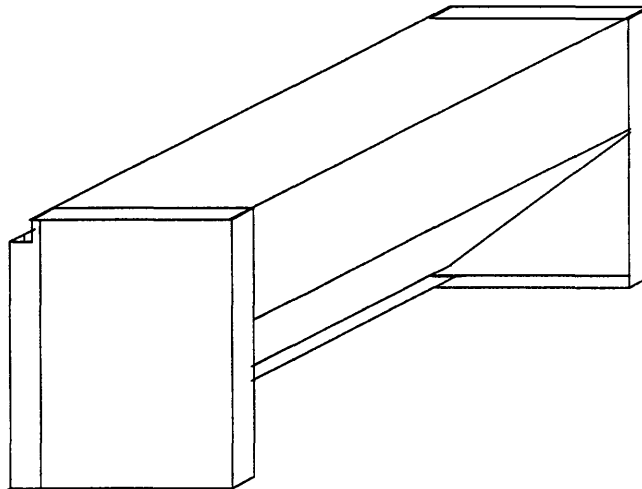

Figure 5-5. 6 Final Hopper Design

The choice between concepts was clear, so a selection matrix was not needed. Concept two was chosen because its material cost, labor cost, and assembly time were lower than those of the first concept. Both concepts use roughly the same amount of sheet metal, but concept one must have additional material for the frame. Also, it was estimated that one person could bend and assemble the hopper of concept two in less time than it would take two people to make a

conventional hopper. This is illustrated in Table 5-5.1 which shows a break down of estimated assembly times.

Concept 1 Traditional Frame 1 Person		Concept 2 Folded Sheet Metal 2 People	
<u>Operation</u>	<u>Time, min.</u>	<u>Operation</u>	<u>Time, min.</u>
Laser Cut Sheet Metal	8	Cut Sheet Metal	10
Bend Sheet Metal	25	Cut Frame Material	10
Assemble	5	Assemble, Weld Frame	20
Stitch Weld	10	Continuous Weld on Sides	15
$\Sigma =$	48	$\Sigma =$	55

5.5.3 Hopper Door Latch

Concepts for hopper door latches were judged using four criteria:

- ease of use
- manufacturability (amount of welding, machining, or other preparation)
- ease of assembly
- confidence in functionality

5.5.3.1 First Concept for Hopper Door Latch

In the first concept, the door would be held shut by a pair of spring loaded clamps attached to the bottom of the hopper. When shut, the clamps would grab the lower edge of the hopper door. Either a “pull wire” or a lever directly mounted to the latch shaft would be activated, causing the latch to rotate away from the door. The door would then be forced open under pressure from the contents.

Assembly would involve bolting or welding the two clamp assemblies to the lower edge of the hopper. Here, mechanical fastening could be done faster. The holes in the bottom of the hopper would be added during laser cutting. Then the latch assemblies could be bolted on in a few seconds. This would be preferred to welding where the pieces would have to be positioned by hand, clamped in place, and then welded.

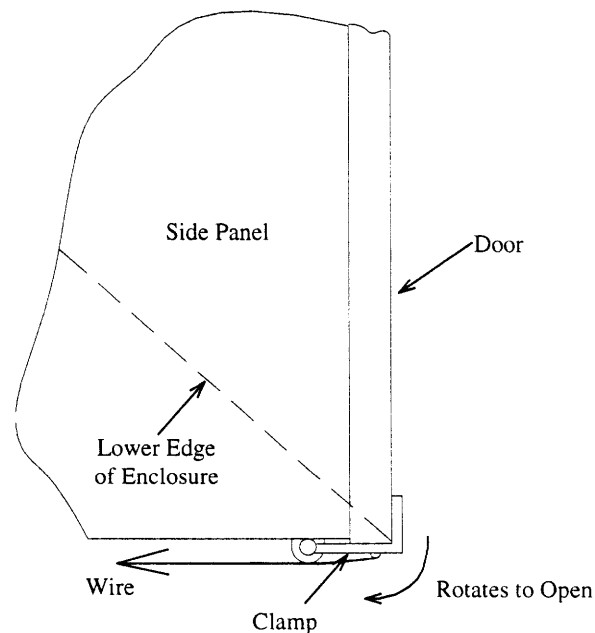

Figure 5-5. 7 First Concept for Hopper Door Latch

5.5.3.2 Second Concept for Hopper Door Latch

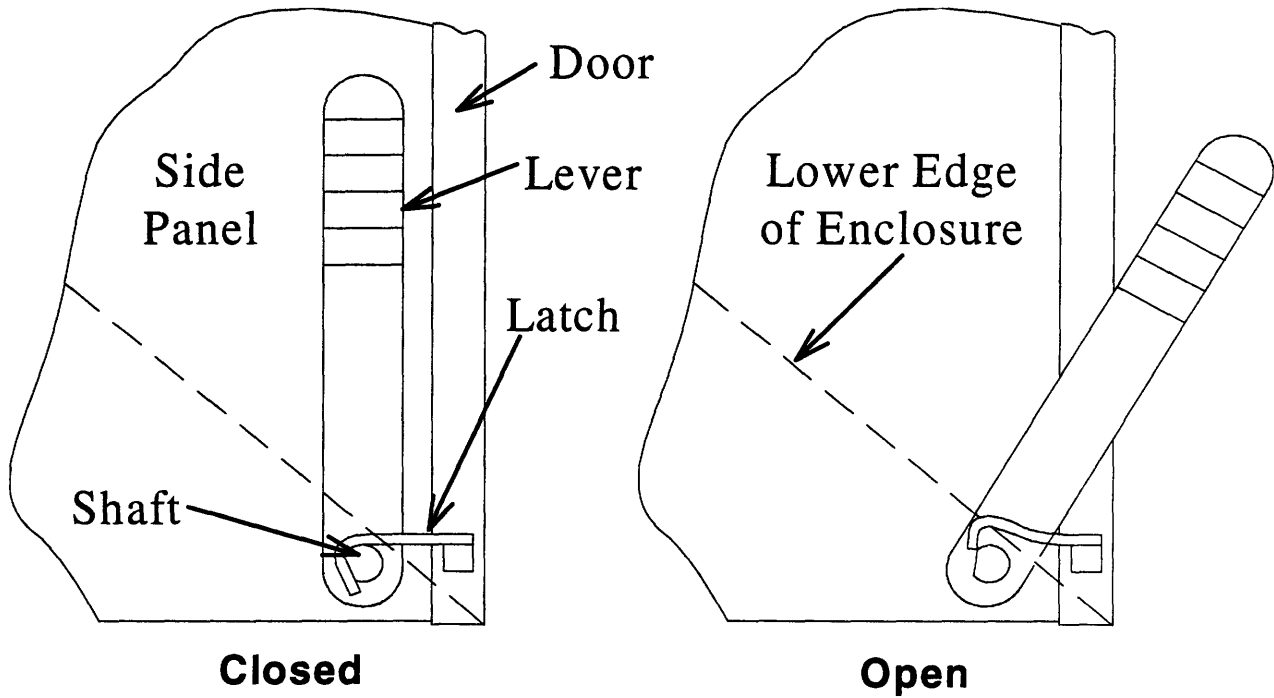

Figure 5-5. 8 Second Concept for Hopper Door Latch

The second concept, shown in Figure 5-5.8, used two latches attached to both sides of the door. The latches, made from bent pieces of sheet metal, would hold a shaft as seen in Figure 5-5.8. The ends of the shaft would be machined as shown in Figure 5-5.9. When the shaft was rotated clockwise, the latches would be forced over the top of the shaft until the end of

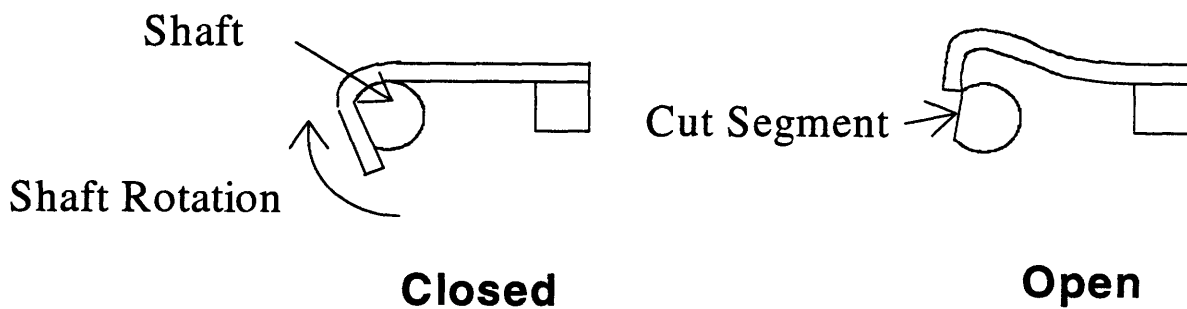

Figure 5-5. 9 Shaft for Second Door Latch Concept

the latches slipped over. To close, the door would be pressed shut until the latches snapped over the shaft. The unique feature of this design was that the latches themselves would spring load the assembly.

Assembly would also be simple. The latches could be bent to shape from the sheet metal blank shown in Figure 5-5.10. Welding (surface b to the hopper) would be preferred to mechanical fastening because a single bolt would not be able to withstand the repeated torque

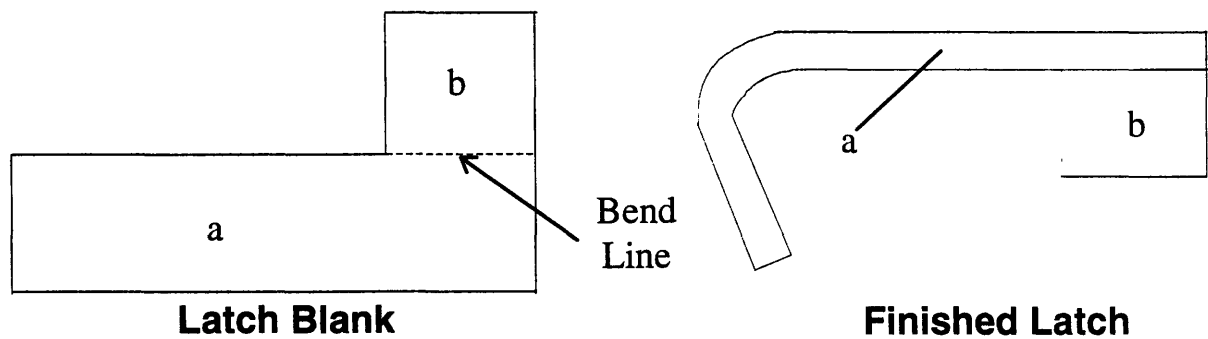

Figure 5-5. 10 Detail For Second Hopper Latch Concept

required to hold the latches in place during opening and closing. Holes for the hopper shaft could be added during laser cutting.

After the shaft was positioned, a plastic washer would be placed between the lever and hopper to act as a sliding bearing. Fasteners would then be placed on the ends of the shaft to hold the assembly together, and in place. Friction between the washer and contacting surfaces would keep the shaft from spinning.

5.5.3.3 Third Concept for Hopper Door Latch

The third concept was similar to the second, the main difference now being that the latch was attached to the actuated shaft rather than to the door. When the lever was in the closed position, as seen in Figure 5-5.11, the latches would each hold a peg which was attached to the

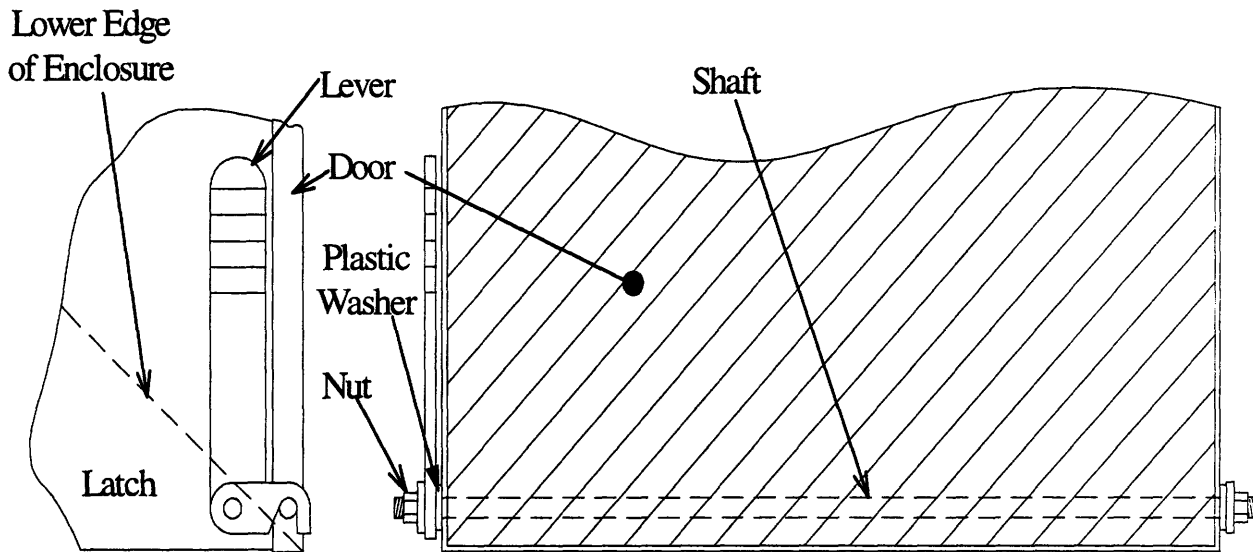

Figure 5-5. 11 Third Concept for Hopper Door Latch

door. When the lever was rotated counterclockwise, the latches would rotate also. At a set angle of rotation, the latches would release the pegs, and the lower edge of the lever would kick the pegs away from the hopper. This would prevent one edge of the hopper door from opening part way, while the opposite end wedged on the other edge of the hopper. When the lever was returned to the closed position, the latches would close over the pegs, locking the door in place. The latch would be held in place by friction as in the last concept.

Fabricating the pieces would be easy. The latches can be machined to a shape which would lock onto the end of a similarly shaped shaft. An example would be to machine the end of the shaft as illustrated in Figure 5-5.12. Holes in the latches would be made to fit the end of the shaft. The lever could be attached in a similar way, or have the machined hole made slightly

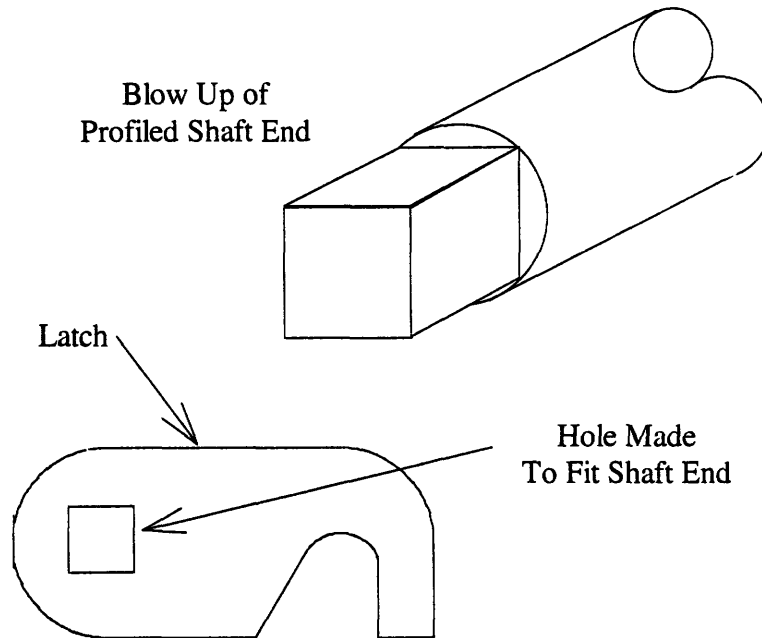

Figure 5-5. 12 Detail of Third Concept Shaft End

bigger than the profiled end of the shaft. The lever would then be welded onto one of the latches. The pegs would be made from bar stock and either welded or held onto the door by fasteners.

Assembly of this concept would be simple. After the shaft was positioned, a plastic washer (same as last design) would be put on, then the lever or lever/latch assembly. The same would be done for the opposite end (with no lever, just latch). Fasteners would be placed on the ends of the shaft to hold the assembly together and in place.

5.5.3.4 Final Hopper Latch Design

A selection matrix was used in which each concept was given a grade. Each criteria was weighted as to its importance to the overall design. Grades and assigned weights can be seen in Table 5.5-2.

<u>Criteria</u>	1 = good, 3 = fair, 5 = poor			<u>Weight</u>
	<u>Concept 1</u>	<u>Concept 2</u>	<u>Concept 3</u>	
Ease of Use	1	2	2	20%
Manufacturability	2	3	3	20%
Assembly	2	4	3	20%
Functionality	4	4	1	40%
Weighted Grade	2.6	3.4	2.4	

The third design was used in the prototype. However, the author noted that the wire activation feature of the first concept could be adapted for use with the third. In a production model, a wire would be run from the latch assembly to the front of the cleaner. The wire would either be attached to the lever or wound around a pulley in place of the lever. This modification would allow the user to operate the hopper door without traveling to the rear of the machine. When this concept was shown to dealers of lawn and garden equipment, the response was most favorable.

5.6 Prototype Frame

The prototype frame was made from wood because it would be easy to modify in case of a design change. The three designs presented in this section were not the result of a concept/weight process, but the result of a concept which progressed from design to design.

5.6.1 First Prototype Frame Design

The first design is shown in Figure 5-6.1. Dimensioned drawings of all frame components are contained in Appendix H.

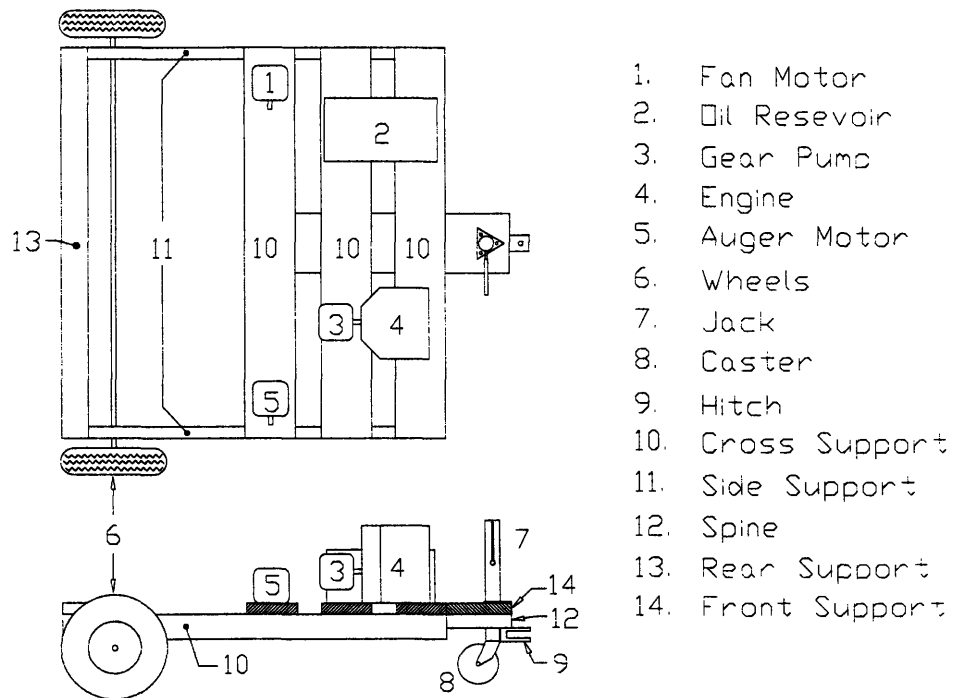

Figure 5-6. 1 First Prototype Frame Design

The frame was to be put together as follows. The side supports would be laid on top of the cross supports and held in place with wood screws. Next, the frame would be flipped over and the spine fastened in place, again with wood screws. Then an agricultural jack with a pin

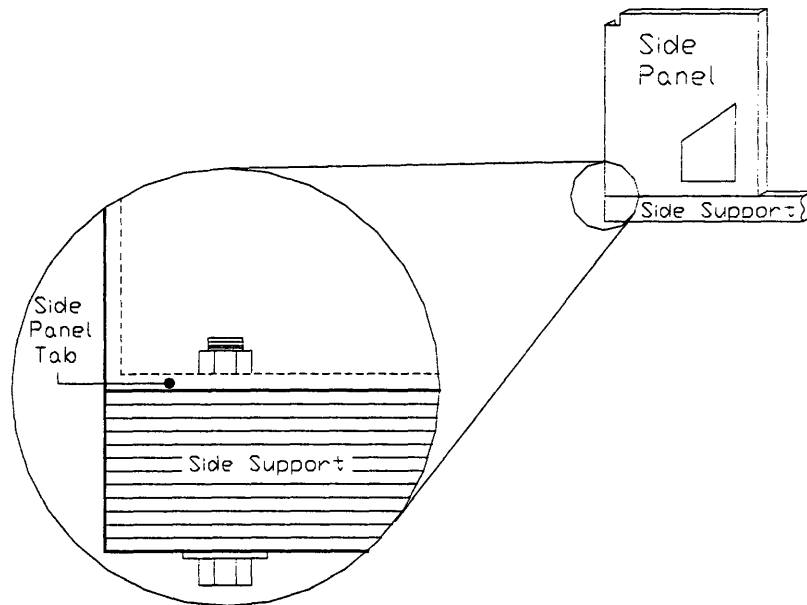

Figure 5-6. 2 Position of Rear Support

hitch and the front support would be added. Last, the hopper would be positioned on the rear of the frame and held in place with fasteners. One joint is shown in Figure 5-6.2.

5.6.2 Second Prototype Frame Design

The first design was changed because of concerns that the engine might shake it apart. While speaking with Fred Cote', the Building 35 shop supervisor, he mentioned that the frame could be made more rigid by adding a piece of three quarter inch plywood on top of the cross supports. This led to the second design seen in Figure 5-6.3. Note, that for clarity, items 1

through 8 are either not shown or labeled, and that these items do not change from their positions as shown in Figure 5-6.1.

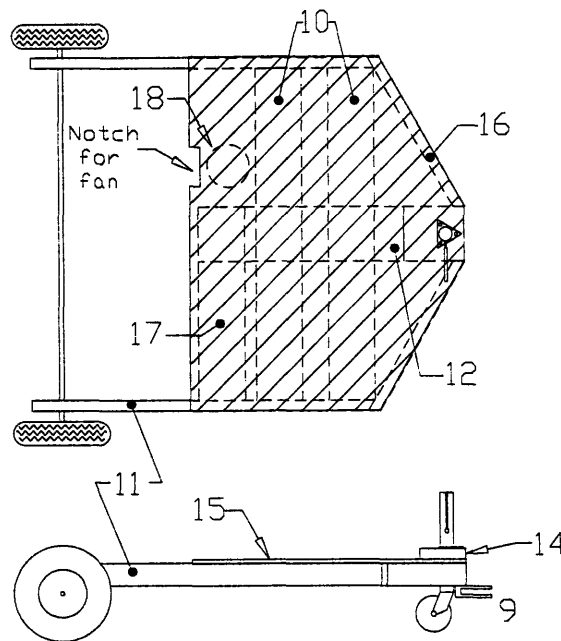

Note: Items 1 - 8 are same as in first frame design, these items are not included at left for clarity. The platform is shown hatched, support members shown as dashed lines.

- 9. Hitch
- 10. Cross Support
- 11. Side Support
- 12. Spine
- 13. Rear Support (deleted)
- 14. Front Support
- 15. Platform
- 16. Angle Support
- 17. Rear Cross Support
- 18. Auxiliary Hose Hole

Figure 5-6. 3 Second Prototype Frame Design

The second frame would be put together much as the first one, however, the cross supports would be placed between the side supports, instead of on top of them. Then the platform would be placed on top of the cross supports, tacked in place with wood screws, and bolted to the spine via the cross supports. One of the cross supports (now called the rear cross support) was cut short to allow room for an auxiliary hose which was to be run through the plywood. Later, this would not be possible as this space was used to mount the fan motor as explained in section 5.3.4.

5.6.3 Third Prototype Frame Design

In the next design, the hitch was changed to a ball hitch when it was learned that all terrain vehicles, (ATV's are one of the target markets for this design) used them instead of pin type hitches. Also, the agricultural jack was not used in this design. A dimension supplied by the distributor of the jack, was incorrect. When the jack and frame were modeled with the

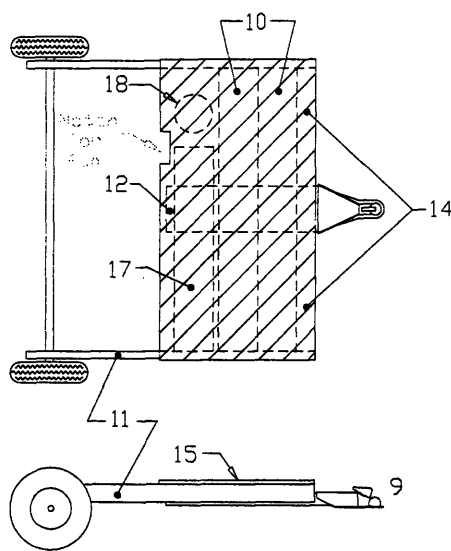

Note: Items 1-8 are same as in first frame design, these items are not included at left for clarity. The platform is shown hatched, support members shown as dashed lines.

- 9. Hitch
- 10. Cross Support
- 11. Side Support
- 12. Spine
- 13. Rear Support (deleted)
- 14. Front Support
- 15. Platform
- 16. Angle Support (deleted)
- 17. Rear Cross Support
- 18. Auxiliary Hose Hole

Figure 5-6. 4 Third Prototype Frame Design

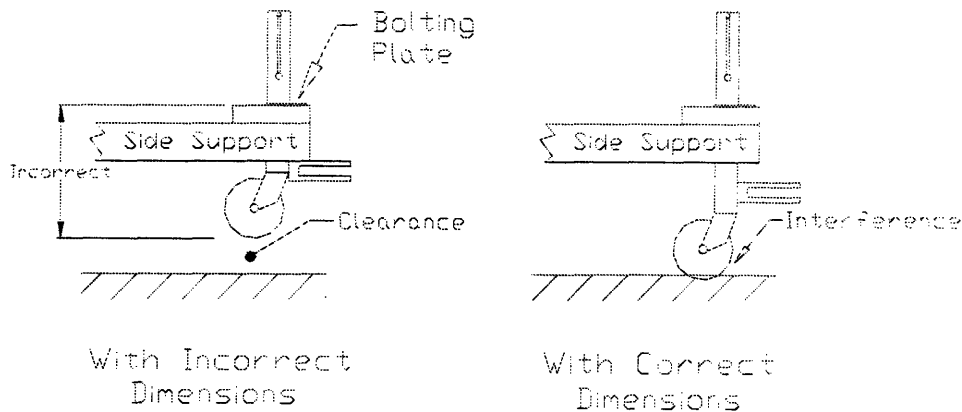

Figure 5-6. 5 Effect of Incorrect Jack Dimension

incorrect dimensions, it appeared that there would be sufficient clearance between the caster wheel and the ground. However, while attempting to build the frame, it was noticed that this would not be the case. After this incident, all future dimensions were obtained directly from the manufacturer and the dimensions of all parts received were verified with those which had been used in modeling.

5.7 Chipper/Shredder

5.7.1 First Chipper/Shredder concept

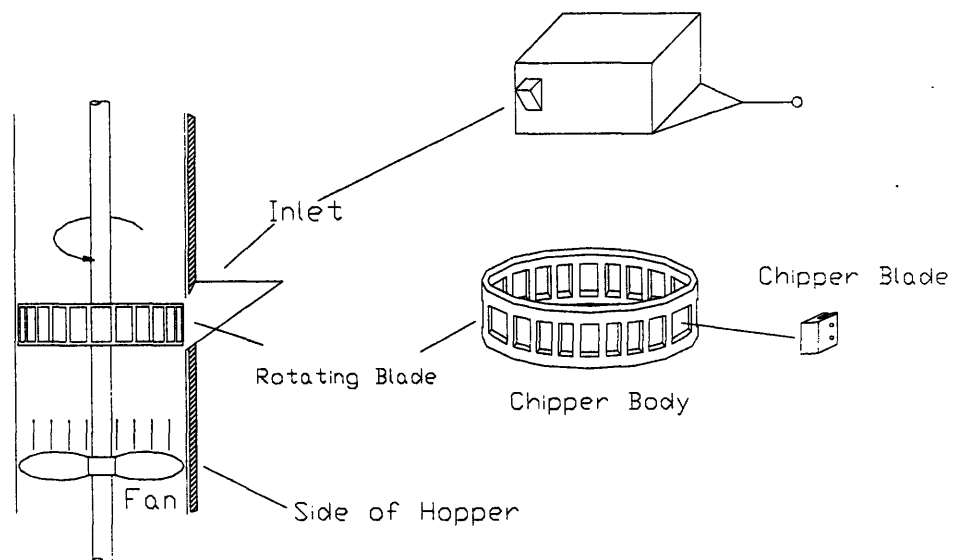

Figure 5-7.1 Initial Chipper/Shredder Design

Two designs were considered. The first design shown in Figure 5-7.1 was for the original axial fan. It used a perforated metal cylinder (chipper body) with blades bolted into the perforations. This assembly was to be mounted in the exhaust chute of the fan on the same shaft as the fan. Another metal chute would attach such that it could be slid over the inlet when the

chipper was not in use. The advantages of this design were that the chipper/shredder was compact and downstream of the fan (fan would blow mulch into hopper). A disadvantage of this design was that it would be difficult to change the chipper blades once they wore out.

5.7.2 Second Chipper/Shredder Concept

When the fan type changed from axial to centrifugal, a new design was needed for the chipper/shredder. The new design seen in Figure 5-7.2 would be made by cutting three rectangular holes in the backing plate of the impeller. The same type of chipper blade seen in Figure 5-7.1 would be used. As debris was fed in through the inlet, it would be cut by the chipper blades, fall in between the impeller blades and be propelled out with the exhaust air. Later the author noticed this design on push debris cleaners with chipper shredders.

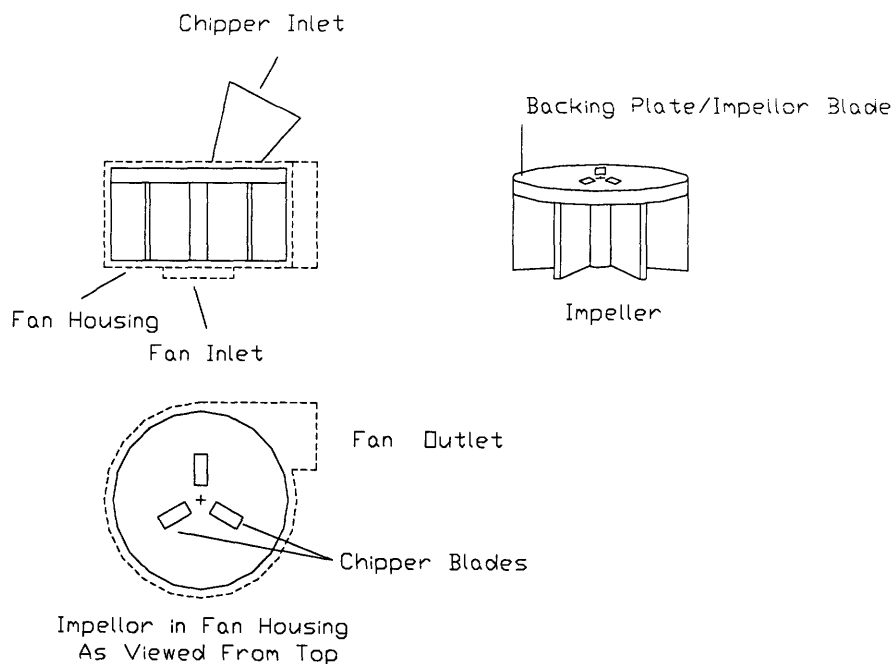

Figure 5-7. 2 Final Chipper/Shredder Design

Chapter 6 Prototype Build

In this chapter, the build of the prototype is to be discussed. Each section covers the design and machining of a major system or component of the machine. Rough analysis of a production and plant layout are also discussed. Note that specific details concerning dimensions and other specifications can be found in the appropriate appendix.

6.1 Auger /Axle Build

6.1.1 Design

A quarter inch thick strip of 90 durometer rubber was glued to the inside of the bearing insert with rubber cement. This design essentially forms a self aligning bearing. Dimensions of the bearing insert, rubber pad, and bearing were picked for a loose fit between the bearing and rubber pad.

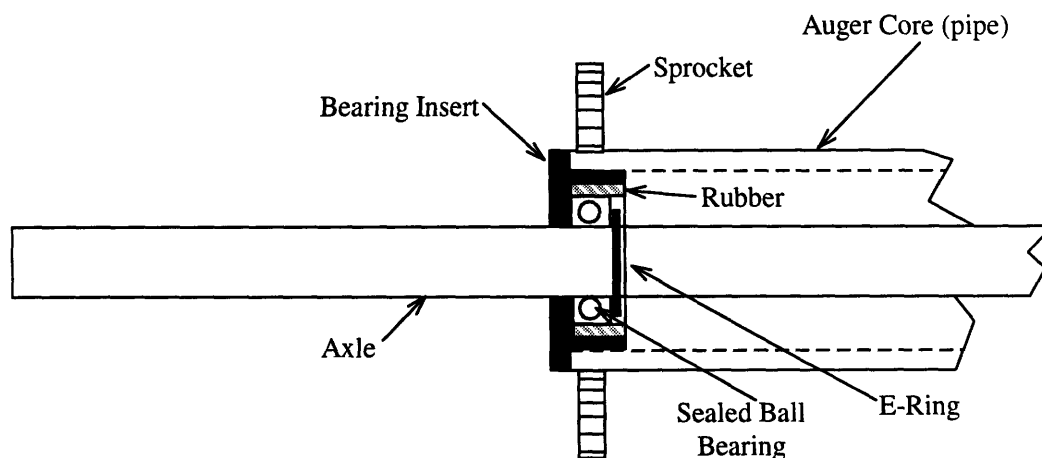

Figure 6-1. 1 Design of Auger/Axle Interface

The assembly was put together by first welding the sprocket to the auger pipe. Then, the axle was placed in the auger and a bearing assembly (insert, pad, and bearing) slid over each end of the axle. The bearing assemblies were fastened to the end of the auger via eight cap screws

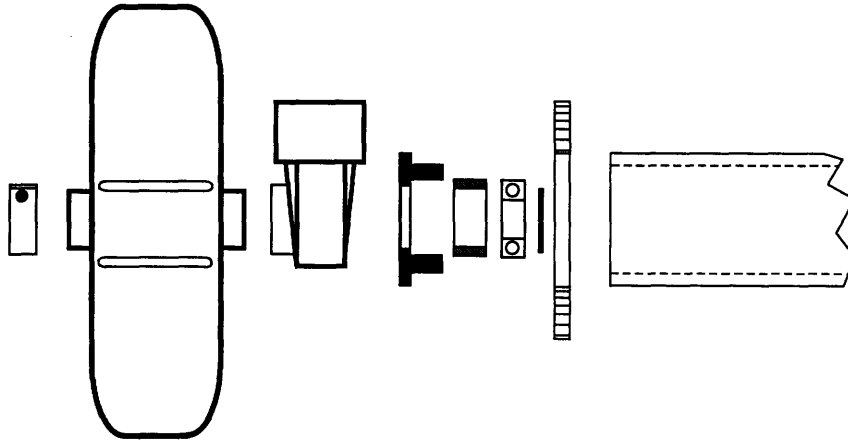

Figure 6-1. 2 Exploded View of Interface

which fit into counter bored holes in the insert. This assembly was then mounted to the frame via two self aligning pillow blocks. Last, the wheels were slid on the ends of the axle and held in place with shaft clamps as illustrated by Figure 6-1.2.

6.1.1.1 Physics

Stress

The diameter of the axle, design, and material were chosen such that the resulting stress was below the material's endurance limit. The maximum misalignment between the axle center line and bearing center line per recommendation of the bearing manufacturer was 0.10 degrees. Loaded shaft deflection relative to the auger ends was estimated to be 2.5 degrees (due to under design.) The bearing assembly (pad and insert) was tested to determine how much deflection the pad would permit before offering substantial resistance.

The rubber insert permitted 5.0 degrees of misalignment between the axle and bearing insert without offering noticeable torsional resistance. The author believed that this was more than adequate compliance to deem the bearing "self aligning." For this design, the thought was that if the bearing insert mounting faces on the auger were sufficiently parallel, the concept would work. As discussed in chapter 7, problems arose with this design. Calculations for axle loading, deflection, and schematics are located in Appendix F.

6.1.1.2 Material

Axle

A hardened steel with good strength and fatigue resistance was needed for the axle. While working at John Deere, the author had seen 4340 hardened steel used to make similar shafts. However, this material would act "gummy" when machined. A close cousin, 4140 hardened steel (125 ksi) was chosen as it machines much cleaner and offers essentially the same mechanical properties.

Attachments

The compliant attachments were to be made from neoprene chord. This material was decided upon after a discussion with Juli King, a sales representative at Green Rubber. The characteristics in favor of neoprene were that it could be easily obtained, wears well, and would not be highly sensitive to extremes of light or temperature.

After the initial discussion, Mrs. King presented neoprene samples of various diameter and durometer. The author tested different lengths of these samples by pulling them through the

lawn of Green Rubber. Of the samples tested, a five inch length of 3/8" diameter, 90 durometer neoprene was the most appropriate choice.

6.1.1.3 Special Requirements

Auger

Parallelness of the auger ends was set to within +/- 3.0 degrees. By maintaining this dimension, a safety cushion of approximately 1.9 degrees was allowed by the bearing assembly.

Axle

A turned surface was sufficient for the prototype axle. The wheel bearings were designed to run on a ground and hardened sleeve which would slide over the axle. These sleeves were provided by the manufacturer

6.1.2 Machining

6.1.2.1 Fixturing/Setup/Approach

Axle

While one end of the rod (69.75 inches long and 1.00 inches in diameter) was machined, the other was cantilevered out of the opposite end of the head stock. To prevent the lathe from driving the cantilevered portion of the shaft to resonance, a support was used to restrain the cantilevered end. The ends of the axle were machined to size, then grooves were added for the snap rings. Rough edges or burs were removed with a file or emery cloth.

Auger

The inner and outer diameter of each auger end were out of the tolerances set for pipe by industry standards. As such, the bearing inserts would not fit in the ends of the pipe, and the sprocket could not fit the outside. A Makita™ hand held grinder was used to open the inner

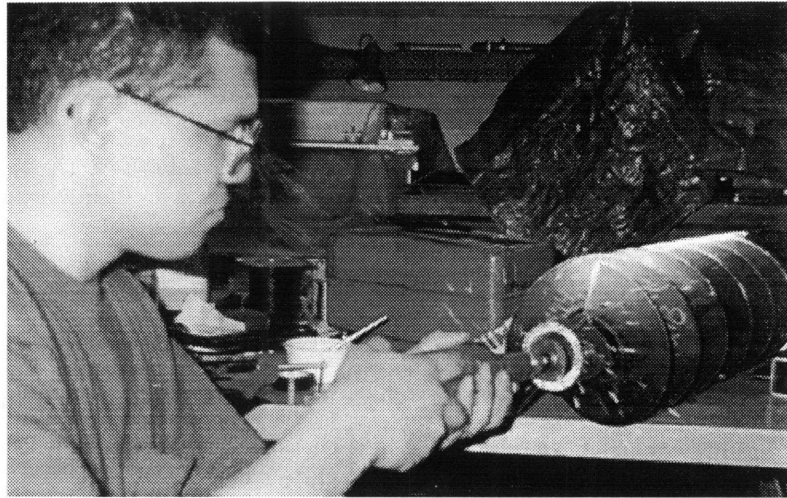

Figure 6-1. 3 Opening Auger Inner Diameter

diameter of the pipe to the desired dimension. Assembly was further complicated as the hardened bore of the sprocket had approximately ten degrees of taper, reducing the inner diameter of one end well below the outer diameter of the pipe. Two carbide tools, a boring bar, one hour, and a lot of lubricant were used to turn the sprocket bore to fit the auger pipe.

Originally, the holes in the flighting were to be drilled. However, Professor Slocum suggested that Bill Mischkoe, owner of Iron Dragon, use a cutting torch to place holes on approximately two inch centers at a distance of one inch from the outer edge of the flighting. These holes would later be used to mount the flexible attachments to the auger.

The ends of the auger were ground flat and to within roughly three degrees parallel (a long process) of each other using the hand held Makita™ grinder. Parallelness was checked by mounting the auger on a flat plate (mill bed), checking the "perpendicularness" of one end of the auger with respect to the plate, then comparing this measurement to the same for the opposite end of the auger. The holes for attaching the bearing inserts were then drilled and tapped in the ends

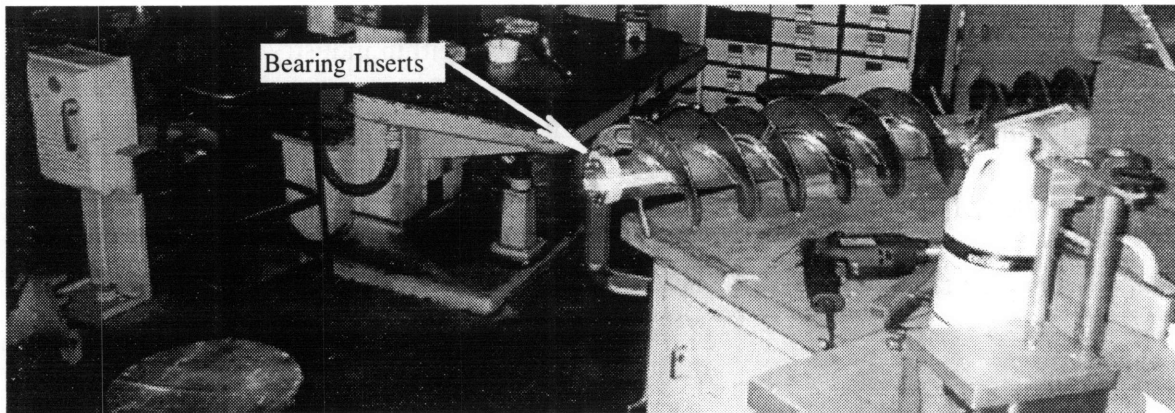

Figure 6-1. 4 Bearing Inserts Used As Drill Pilot

of the auger using the holes in the bearing inserts as guides. Figure 6-1.4 shows the pair of inserts mounted via tape and glue to one end of the auger. This assembly kept the drill bit reasonably perpendicular to the faces of the auger, and assured the threaded holes in the auger would align correctly with the holes in the inserts.

6.1.2.2 Problems

Auger

Drilling the holes in the end of the auger was difficult because the pipe had been welded, leaving hard spots in some places. This made drilling some of the holes difficult. Usually, the drill bit required sharpening after each hole.

As mentioned previously, the inner diameter was not within industry tolerance. Extra time was spent removing material from the inner diameter and weld slag from the outer diameter with a hand grinder. The hand grinder was used, as mounting the auger on a lathe was not possible. Turning the tapered bore of the hardened sprocket to fit the auger pipe was not a planned activity.

Axle

Machining the hardened 4140 steel was also more difficult than expected. Depending upon the speed of the lathe and the diameter of the rod, there was a small window (about 0.020 inches to 0.025 inches) in which removal of material was consistent with the value dialed in on the lathe. For example, if the lathe was set for a cut deeper than this, say 0.0280 inches on the diameter, it would remove up to 0.0070 inches extra and leave a very poor finish. If depth of cut (diameter wise) was set for 0.0180 inches, the same finish resulted, and variation from previous diameter could be as much as approximately 0.0220 inches.

There was little the author could do to fix this problem. The machines on which the material was fabricated were old and did not have the dynamic stiffness needed to cut the pre-hardened material. Fred Cote', a lab technician in the LMP machine shop, was asked if this

material could be machined on a lathe with satisfactory results. The answer was yes, but the more robust, numerically controlled machines in the adjacent shop would be required. Due to scheduling difficulties with the machines and the fact that only two pieces were needed, the author was not able to use the machines.

To minimize the problem, stiffness of the force loop through the machine was increased by reducing the amount of shaft between the head stock and tail stock, then reducing the distance over which the tool was cantilevered. The adjustments of these and other parameters had little effect, so the "window of good machining" was chased as a moving target.

Attachments

The compliant attachments were made by cutting the neoprene chord to length, then wrapping one end of each attachment with electrical tape. This was necessary as the diameter of many of the 120 cable guides varied in diameter by as much as 0.060 inches. As described in section 5.1.5.1, the wrapped ends were slid into the cable guides, then attached to the auger using fasteners.

6.1.2.3 Finished Pieces

The finished assembly is shown mounted to the machine in Figures 6-1.5 and 6-1.6. Note that the machine now has two axles. This was done as a safety precaution. When first designed, the load on the axle was underestimated by approximately 50%. To ease the stress on the axle, another axle was added to the frame immediately in front of the main axle.

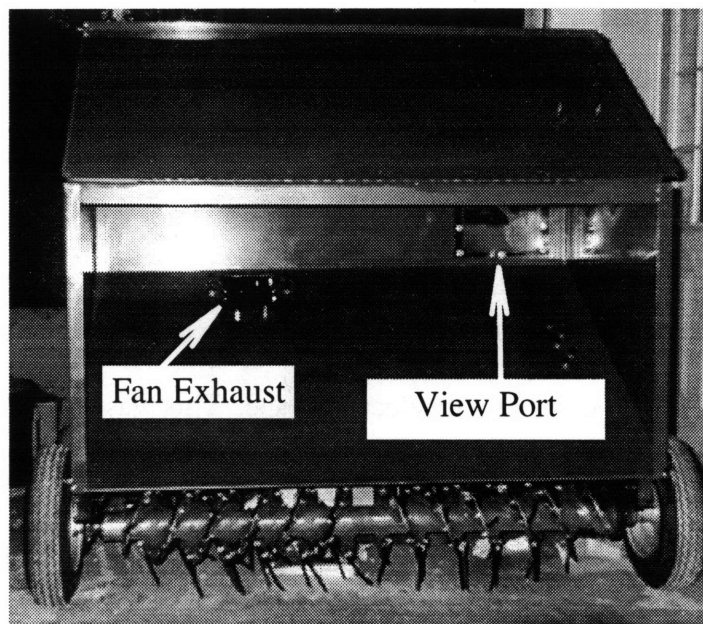

Figure 6-1.5 Auger As Seen From Rear of Hopper

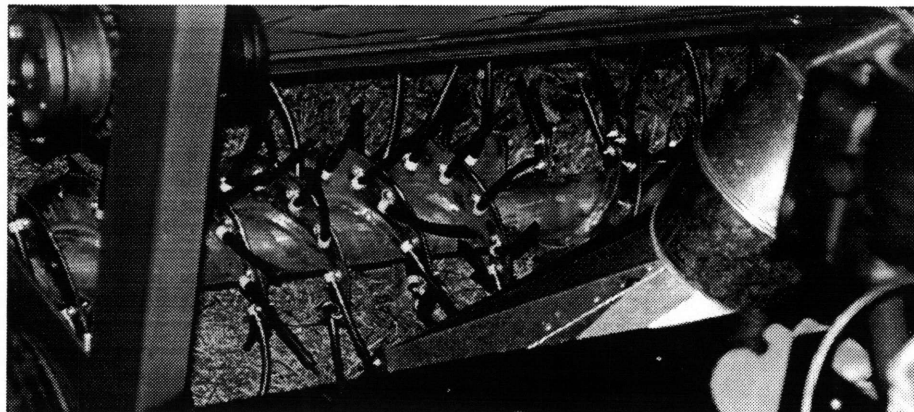

Figure 6-1.6 Auger With Attachments

6.1.2.4 Time

Table 6-1. 1 Time to Machine Auger/Axle Components (in hours)				
Task	Machining Time		Set Up	Misc.
	Planned	Actual		
Turn Axles (two were made)	2.00	4.50	0.25	0.25
Grind Pipe Ends Parallel	1.00	1.50	0.25	0.50
Grind Pipe ID	0.00	2.00	0.25	0.00
Turn Sprocket ID	0.00	1.00	0.50	1.00
Drill/Tap 16 Holes	2.00	7.00	0.25	2.00
Machine Bearing Inserts	2.50	2.00	0.30	0.00
Cut and Glue Rubber to Inserts	0.25	0.25	0.00	0.00
Σ=	7.75	18.25	1.8	3.5
Comparison:	12.75	37.5		

Some of the components for the axle and auger were made while the author was still learning to use machines. The time needed to complete many of the tasks was underestimated due to lack of experience in judging machining time. Most of the miscellaneous delays were either due to waiting for an open machine, sharpening tooling, or obtaining tooling. Other major discrepancies are explained below.

Turn Axles- turning the axles took longer than expected because of the stiffness difficulties discussed previously.

Drill/Tap 16 Holes- Drilling and tapping the holes (approximately 1.50 inches deep) in the ends of the auger was much more difficult than expected. Average time to drill and tap a hole was approximately 20 to 25 minutes.

6.1.3 Production Model

6.1.3.1 Design

Axle/Bearing Assembly

During testing of the prototype, the "bearing potted in rubber" design worked fairly well,

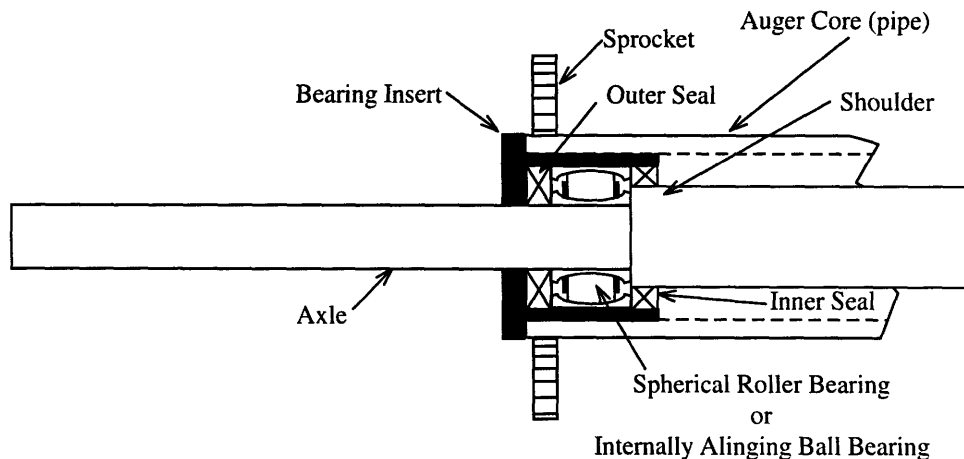

Figure 6-1. 7 Auger/Axle Design For Use in Production

but would momentarily "freeze up" while going over bumps. To find the cause of the problem, the machine was stopped while the auger and fan remained running. The author loaded the machine by bouncing on the frame near the axle. When this was done, the same symptoms were seen. Note that in the cases mentioned above, the rigid, inner auger core did not come into contact with the ground or any other hard objects. Another problem was the design was that the bearings were loaded axially via the snap ring.

As the self aligning concept had not worked, the "true" self aligning design shown in Figure 6-1.7 would replace the "rubber aligning" bearing. In a production, the slope of the axle would be reduced by using a larger diameter axle, and a smaller, lighter hopper (yet to be discussed.)

Auger Flighting

A change would also be made to the flighting of the auger. During testing, the author realized that the flighting need only extend from the ends of the auger to just behind the edges of the nozzle inlet. Flighting directly behind the auger was not needed as the debris in the vicinity was already within reach of the nozzle. Fingers, extending from the auger core in a configuration similar to a rotary brush would replace the flighting in this area. By using this design, the amount of costly flighting can be reduced.

Attachment Design

The design of the attachments would also change. Using single fingers and multiple fasteners as in the prototype would be labor and machining intensive. In the production model,

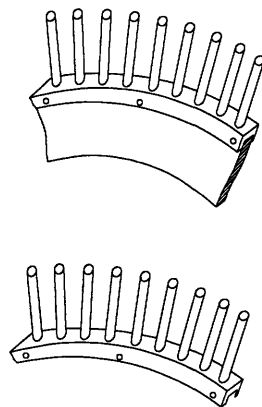

Figure 6-1. 8 Production Auger Attachment Design

the design shown in Figure 6-1.8 would be used. As explained in chapter 5, this design requires machining and labor to manufacture.

6.1.3.2 Necessary Material

To mass produce this assembly, the following materials would be used.

Table 6-1. 2 Components for Production Version of Axle/Auger Assembly

<u>Component</u>	<u>Material</u>	<u>Process</u>	<u>Additional</u>
Axle	4140 Steel	Turned and Ground	
Auger Pipe	HRS Pipe	Face, Drill, Tap Ends	Drill and Tap Eight Holes
Auger Flighting	16 Gauge Steel	Weld to Pipe	Sectional Flights Purchased
Bearings	Self Aligning	N/A	Must Also Purchase Seals
Drive	Belt Drive	Welded to Pipe	-----
Attachments	Neoprene	Molded	Final, 90 Durometer
Bearing Container	Cast Iron	Die Cast	Cast to Finish Shape
Container Fasteners	1/4-20 Cap Screws	N/A	Four Per Side

6.1.3.3 General Discussion

The bearing containers would probably be die cast. This would allow for large quantities to be made inexpensively and close to final dimension. Enough so, that perhaps only a light finish cut would be needed on their inner diameter. These parts would be purchased to avoid the tooling and environmental costs which come with a casting facility.

There are three options for the axle. The first, is to purchase pre-hardened steel rod for the axle so that buying a press for post heat-treat straightening of the axle can be avoided. Second, the axles could be purchased as finished from an outside source. Third, the axle could be machined, heat treated (locally by induction), ground, then straightened if necessary. Cost and justification analyses would be required to determine the most cost effective method.

6.2 Vacuum System

6.2.1 Design

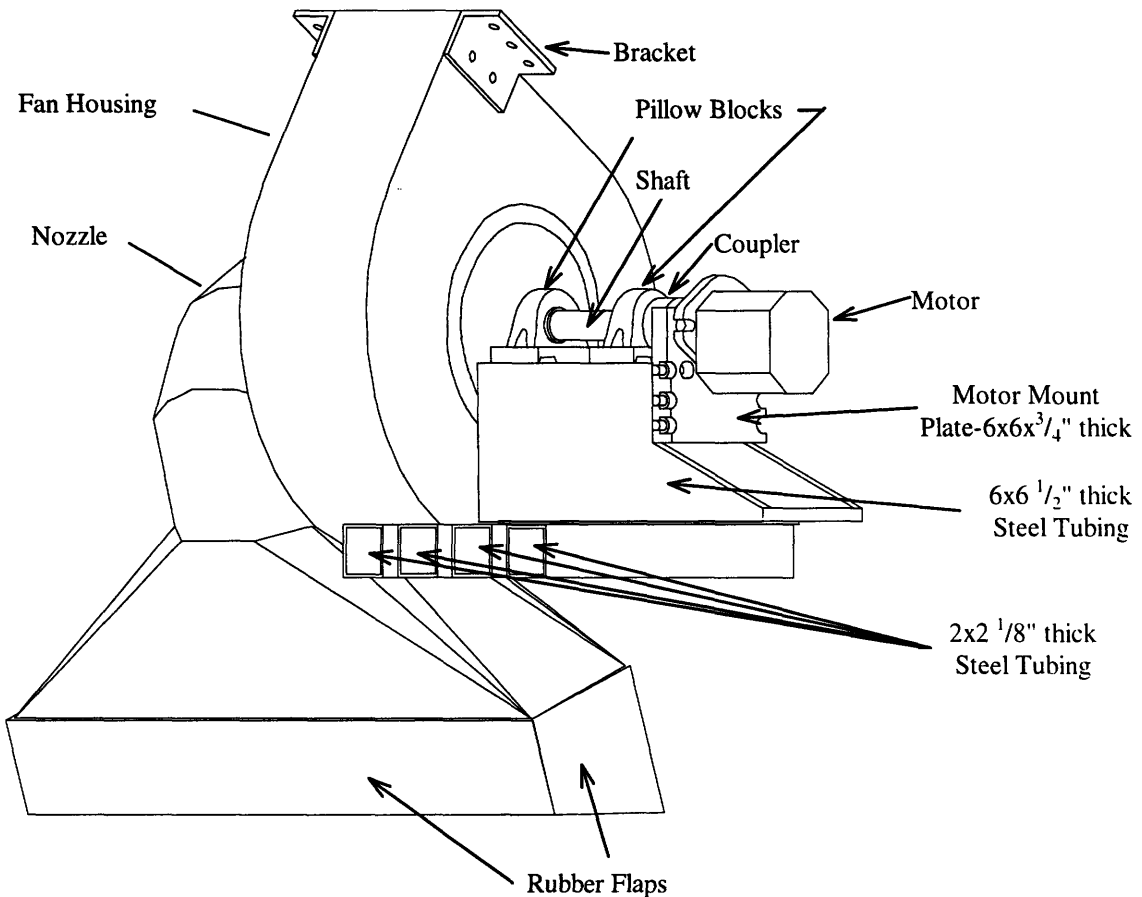

Figure 6-2. 1 Illustration of Vacuum System and Drive

As discussed in section 5.3.4, the hydraulic motor originally was to be attached to the fan housing and drive the fan directly. This design was chosen because it was simple and had been seen on another cleaning machine with a hydraulically driven fan. Professor Slocum pointed out a flaw in this design which required a total redesign. This was a problem as the frame (already built) did not extend under the area where the new fan mount would be positioned.

The new concept, seen in Figure 6-2.1, placed the fan on the end of a shaft which ran through two pillow blocks. The pillow block closest to the fan was clamped in place between the fan blade assembly and a shoulder on the shaft. The other bearing was not rigidly clamped to the shaft, to avoid over constraint. The coupler was placed on the shaft end opposite of the fan. Power was delivered from the hydraulic motor, through the couplers, shaft, and then to the fan. The motor was mounted on a plate of steel which was fastened via cap screws to the milled end of a large piece of steel tubing.

The fan housing was supported via brackets which attached to the angled lower edge of the hopper body. The rest of the system was cantilevered from the frame by four 2"x2" pieces of steel tubing which pass under the large piece of steel tubing. The tapering edge of the large tubing was attached to the hopper and frame (just below the access holes.) Figure 6-2.2 shows the finished assembly from the top/front of the machine. Figure 6-2.3 shows how the assembly was mounted to the underside of the frame.

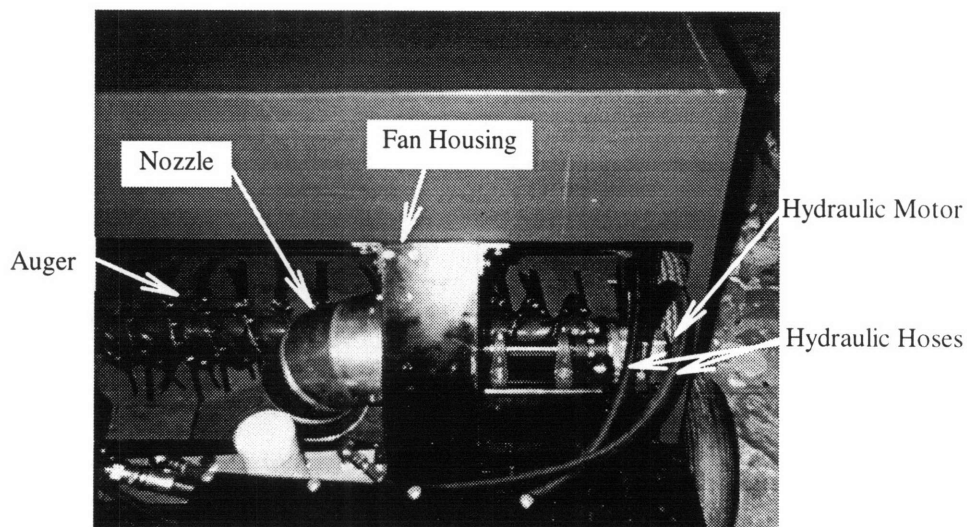

Figure 6-2. 2 Vacuum System of Prototype

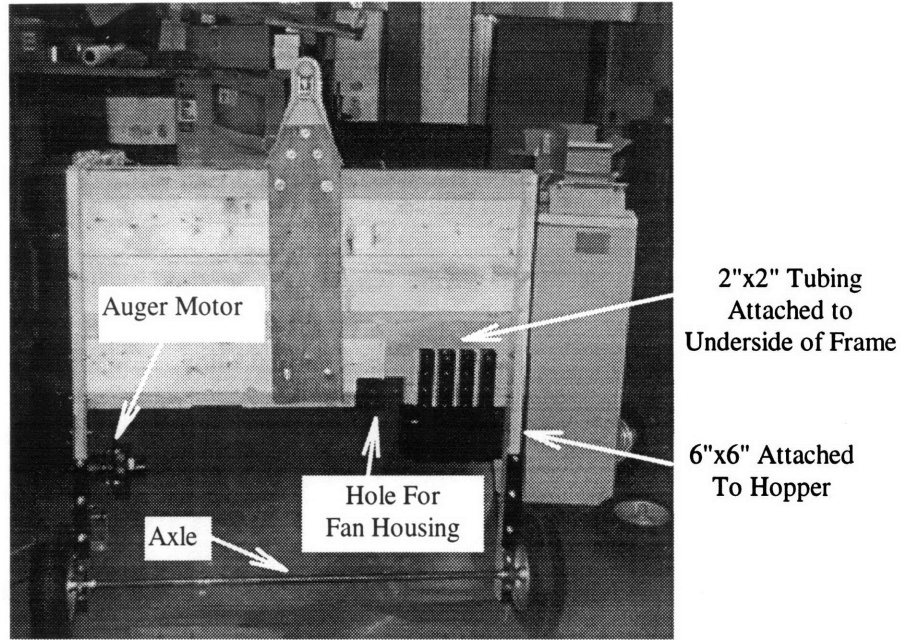

Figure 6-2. 3 View of Vacuum System Attached to Frame

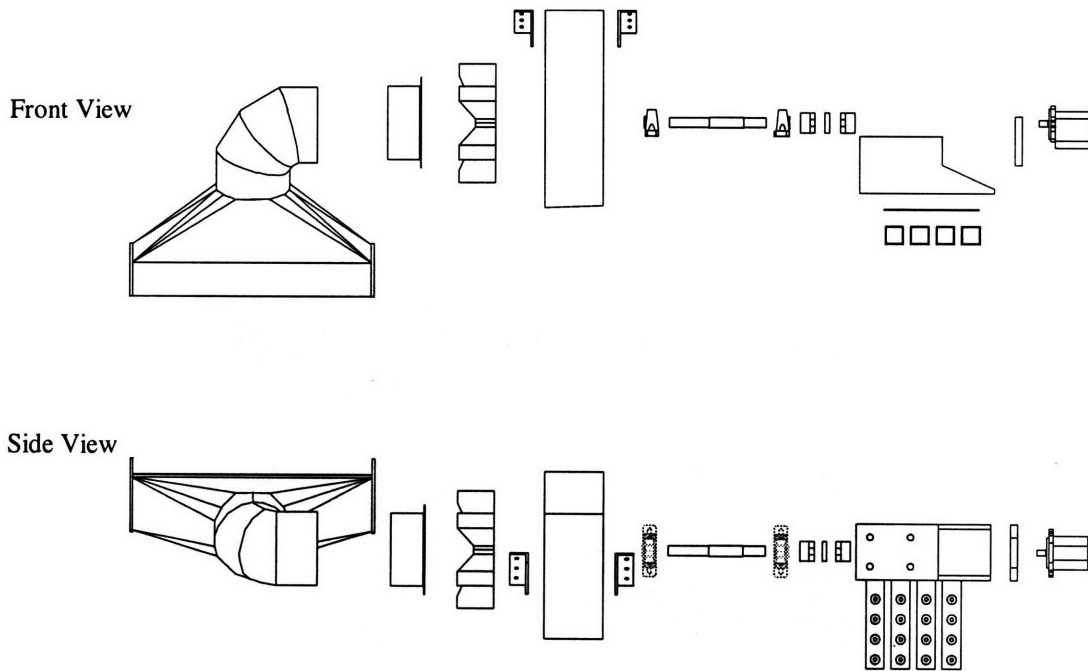

Figure 6-2. 4 Exploded View of Fan Drive

6.2.1.1 Physics

With the original design, Professor Slocum noted that if a piece of debris were to become stuck in the rotating fan, large forces would be transferred to the shaft and bearings of the hydraulic motor. Also, non-steady torques and moments from such objects or objects which impacted the fan blades could fatigue the shaft. Static and fatigue analyses were done to find the appropriate shaft diameter, and dimensions for key ways and shoulders.

6.2.1.2 Material

A hardened steel with good strength and resistance to fatigue was needed for the fan shaft. As discussed in section 6.1, a good material for this type of application was a 4140 hardened steel (125 ksi.) The four pieces of 2"x2" tubing and the 6"x6" piece of tubing were made of regular steel tubing. Strength of these pieces was more an issue of size than material.

6.2.1.3 Special Requirements

A surface finish of approximately 30μ was specified to prevent fatigue of the shaft. Also, the coupler spider between the coupler on the fan shaft and the coupler on the fan motor was rated for 1.0° of misalignment. To satisfy the specification, the perpendicularity of the bearing mounting surface, and pump mounting surface were to be kept to within 0.50° . Also, the upper surface of the 6"x6" steel tubing was ground flat and the sides of the pump mounting plate were ground parallel (to within 0.50° .)

6.2.2 Machining

6.2.2.1 Fixturing/Setup/Approach

Large Steel Tubing (6"x6")

The tube was cut to length, allowing extra stock of 1/8" in spots to be milled. Then the top and bottom surfaces were ground flat in a vertical face grinder. Next the angled edge and edges for mounting of the motor mounting plate were cut to shape. Fixturing was made to hold the piece to a horizontal mill as shown in Figure 6-2.5. The end of the piece and mounting surface for the pump mounting plate were then milled. The four mounting holes for the pillow blocks were drilled in the top surface of the piece, and twelve holes were drilled in the bottom to

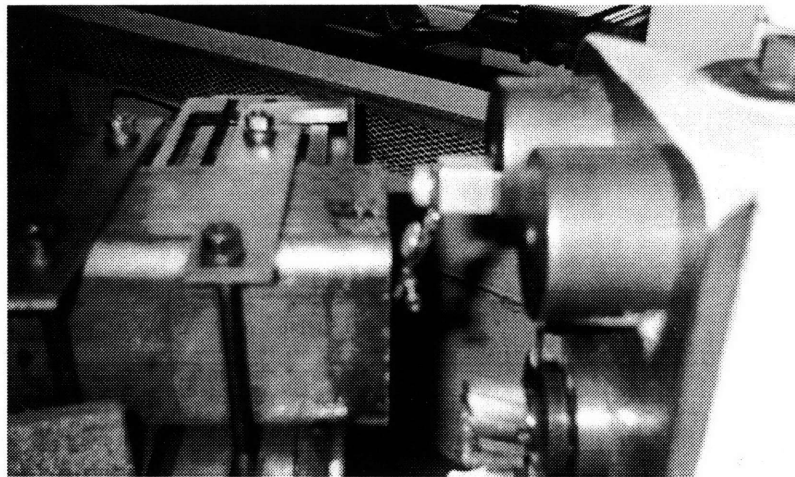

Figure 6-2. 5 Steel Tubing on Horizontal Mill

match the twelve holes in the shim (see next paragraph) and 2"x2" pieces of steel tubing. Last, six holes were drilled and tapped in the surface to which the motor mount would be fastened.

Shim

Dimensions of the hopper and machine resulted in a gap between the large tubing and the four small pieces of square tubing. A shim was made from a $\frac{1}{8}$ " thick piece of steel sheet. Twelve holes were drilled in the shim to match the twelve holes in the tubing discussed previously.

Small Steel Tubing (2"x2")

The four pieces of tubing were cut to length, then 14 holes were drilled in each (7 per side.) On one side, seven of the holes were to be drilled to 1.50 inches diameter to allow access to the nuts inside as shown below. However, holes large enough to tighten the bolts with a socket could not be machined without causing vibration in the piece (later the author learned of a tool called a hole saw which should have been used.) The bolts were slid in from the bottom,

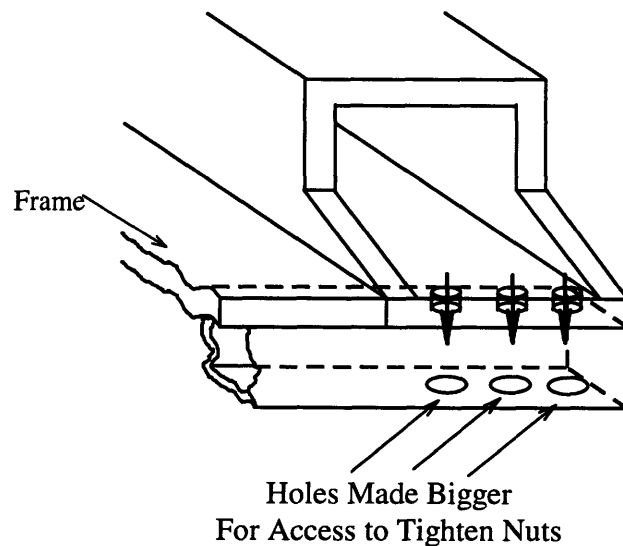

Figure 6-2. 6 Illustration of Fastening of Steel Tubing

held in position from below (through holes too small to fit a socket,) then tightened with a box end wrench from an open end of the tubing.

Motor Mounting Plate

The mounting plate was cut to size, then ground on the vertical surface grinder to make the sides parallel. Holes were then drilled and counter bored for the heads of the cap screws which would fasten the mounting plate to the large piece of steel tubing.

Fan Shaft

A hole was drilled and tapped in the end of the shaft. The fan assembly was held on the shaft by a bolt and large washer which kept the fan assembly pressed against the shaft shoulder. The fan shaft was turned on a lathe between centers, with a "dog leg" used to apply torque to the shaft. Next, the shaft was ground on a cylindrical grinder, then key ways added using a vertical mill. To reduce the stress concentration at the root of the key ways, a Makita™ hand held grinder was used to radius the root of the key way.

Brackets

Aluminum angle was cut, then drilled to size for the brackets. Holes were drilled in each side to allow for fastening to the underside of the hopper and side of the fan housing. These brackets were used as templates to mark the hopper and fan housing for drilling of fastener holes.

Rubber Flaps For Nozzle

The rubber flaps were cut to shape, then a hand held Makita™ grinder with a rounded drill tip was used to burn/drill bolt holes in the rubber. The rubber flaps were then used as templates to drill fastener holes in the nozzle.

Nozzle

Sheet metal screws were to be run through the nozzle, into the hose adapter of the fan housing. However, the sheet metal of the hose adapter was too thick to allow this. Pilot holes were drilled to make this easier.

6.2.2.2 Problems Machining Components

Machining the steel tubing was more challenging than expected. Special fixturing was required to prevent vibration when these pieces were machined. There were also problems machining the fan shaft. As explained in section 6.1.2.2, there was a narrow window in which the removal of material from the diameter was consistent with that dialed on the lathe. Care was taken to make sure that the final cut on the lathe would fall within this window. If a mistake was made, the shaft might end up a few thousandth undersize. The tolerance on the shaft diameter was +0.0000, - 0.0005 inches, so a mistake would mean starting over again.

A cylindrical grinder was needed to hold this tolerance and provide the desired surface finish. The grinder had not been used for a long period of time and took several hours to set up. When used, it was discovered that one of the bearings in the centers used to hold the fan shaft

had gone bad. This resulted in approximately 0.0015 inches taper along the ground lengths. It took an hour of careful adjustment and grinding to get the piece within the desired tolerances.

6.2.2.3 Time to Machine Vacuum System Components

Task	Machining Time		Set Up	Misc.	
	<u>Planned</u>	<u>Actual</u>			
Make 6"x6" Tube	5.00	10.00	2.00	1.00	
Make Shim	1.00	0.75	0.25	0.00	
2"x2" Tubes (4)	2.00	3.00	0.75	0.00	
Motor Mounting Plate	2.00	4.00	0.75	1.00	
Fan Shaft	4.00	6.00	6.00	0.00	
Brackets	1.00	0.75	0.25	0.00	
Rubber Flaps	0.50	1.00	0.00	0.00	
Nozzle	0.25	0.50	0.00	0.00	
	$\Sigma=$	15.75	26.00	10.00	2.00
	Comparison:	15.75	38.00		

Major discrepancies between the planned and actual time are discussed below.

6"x6" Tube

The author underestimated the amount of time needed to complete the various operations. The two hours listed under set up time were from the multiple set ups which were done during the many different machining steps. The miscellaneous time listed was for time spent waiting for access to machines.

Motor Mounting Plate

The time needed to drill and counter bore the six holes in steel was underestimated. A, "miscellaneous" hour was also spent troubleshooting a problem with the vertical grinder.

Fan Shaft

Problems with material removal in turning and grinding (taper problem) the axle to dimensions account for most of the discrepancies. Approximately an extra half hour was spent drilling and tapping the bolt hole in the end of the hardened shaft. In addition, five of the six set up hours were spent troubleshooting problems with the cylindrical grinder.

6.2.3 Production Model

6.2.3.1 Design

Fan Mount

After the author designed and built the assembly to isolate the motor bearings from loading, it was learned that a device was manufactured to do the same thing. The device is called an "outrigger." This device would be purchased, then mounted to the angled underside of the hopper. Mounting the drive on the underside of the hopper would be better than mounting it via the frame as in the prototype. In the prior case, one only has to worry about the relationship between the outrigger shaft and the drive hole in the fan. In the latter, the relation between the frame and angled underside of the hopper would add another variable

Fan and Housing

A similar type of fan and housing would be used and fastened to the hopper. The brackets used to hold the housing would be made as part of the housing.

Fan Mounting

The analysis from section 5.2, showed that a fan mounted in the vertical shaft position would use less power. Ideally, in designing the production model, both types would be set up and tested to verify the accuracy of the loss factors used in the model. If found to be correct, a cost analysis would then be used to determine if the money saved by purchasing a smaller engine (with vertical design) would outweigh the extra cost of the frame needed to support the fan and fan shaft (fan shaft not supported by fan, must have exterior means of anchor.)

6.2.3.2 Necessary Material

To mass produce this system, the following materials would be needed.

Table 6-2. 2 Components for Production Version of Vacuum Assembly

<u>Component</u>	<u>Material</u>	<u>Process</u>	<u>Additional</u>
Fan Shaft	4140 Steel	Turned and Ground	(may come with outrigger)
Fan Housing	14 Gauge steel	Laser Cut Blanks	Bend and Weld Blanks
Nozzle	16 Gauge Steel	-----	Stock Item, Purchase
Out Rigger	Purchased	N/A	-----
Rubber Flaps	Neoprene	Molded to Shape	60 Durometer, Purchased
Couplers	Purchased	-----	-----

6.2.3.3 General Discussion

Most components would be purchased to avoid the labor (overhead) cost in making them within the company. The exceptions would be the fan housing and fan shaft, as they could be made on machinery used to make the hoppers and axles (if not farmed out.)

6.3 Power System

6.3.1 Design

Note: Details on the mechanical parts of the auger and fan drive were covered in sections 6.1 and 6.2 respectively. The last major system of the drive train, the pump assembly, is covered here.

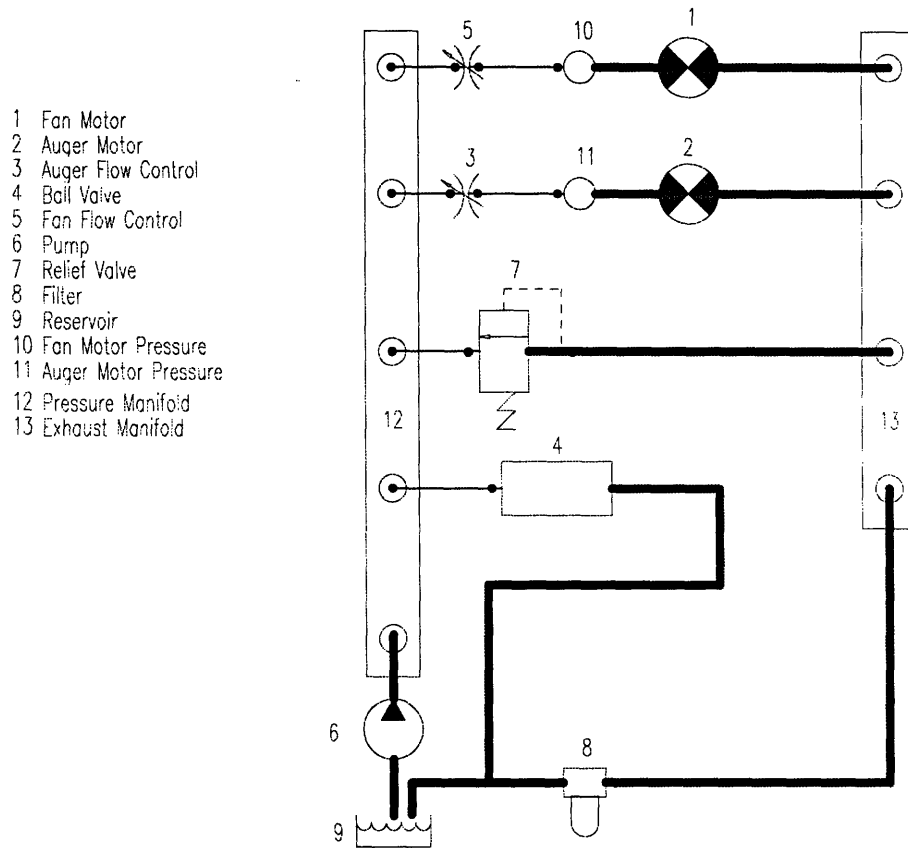

Figure 6-3. 1 Schematic of Power System

Hydraulics were used so the speeds of the fan and auger could easily be varied. They were also used as measuring the power of each component could be done easily with a pressure gauge and tachometer (speed of components proportional to flow rate.) The following figures use finished pieces to illustrate the mounting of the hydraulic motors and pump.

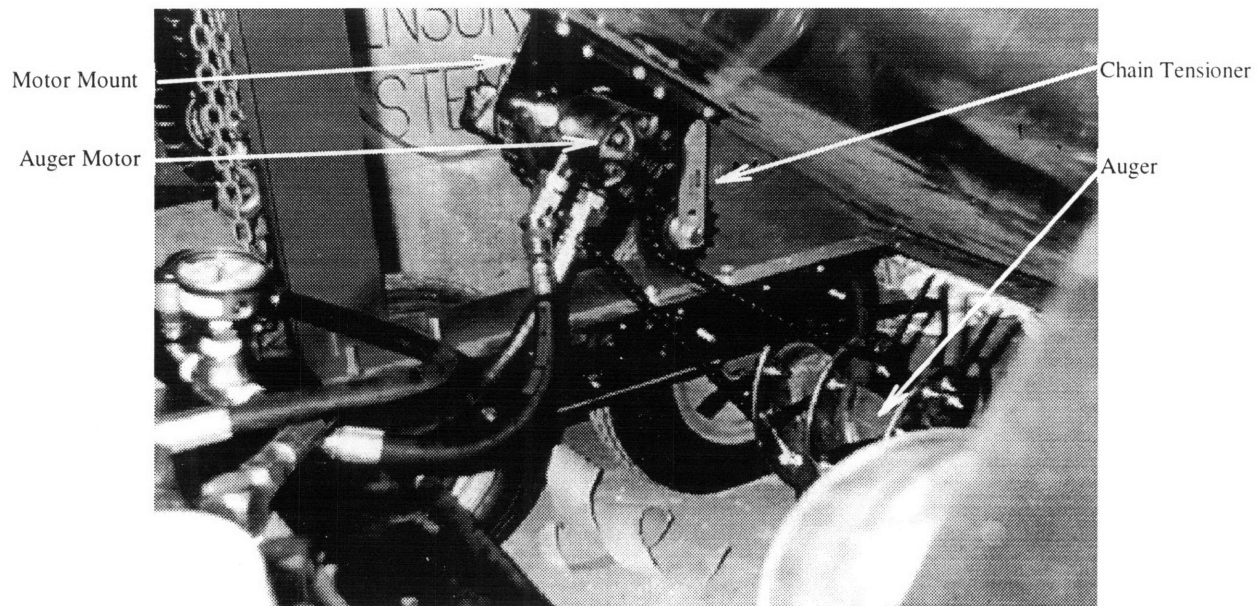

Figure 6-3. 2 Illustration of Auger Drive

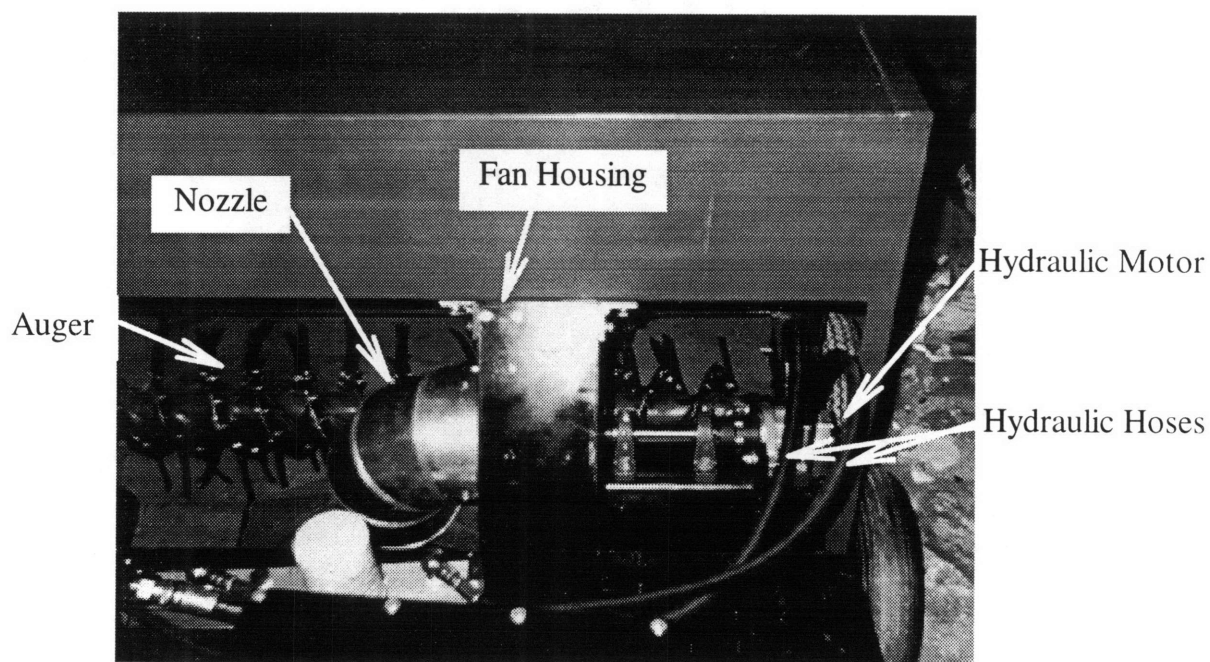

Figure 6-3. 3 Illustration of Fan Drive

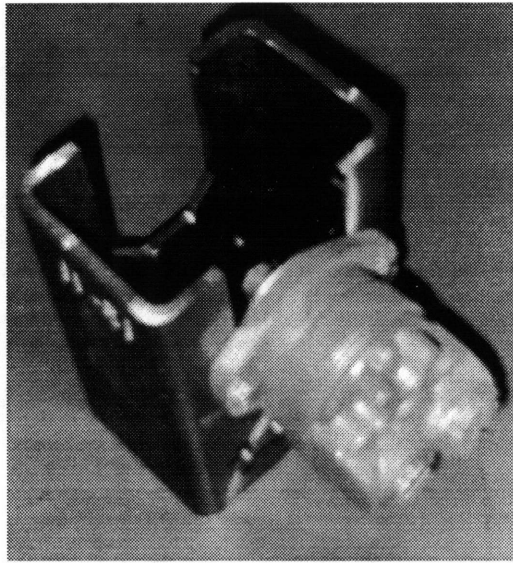

Figure 6-3. 4 Pump Attached To Pump Mount Prior to Assembly

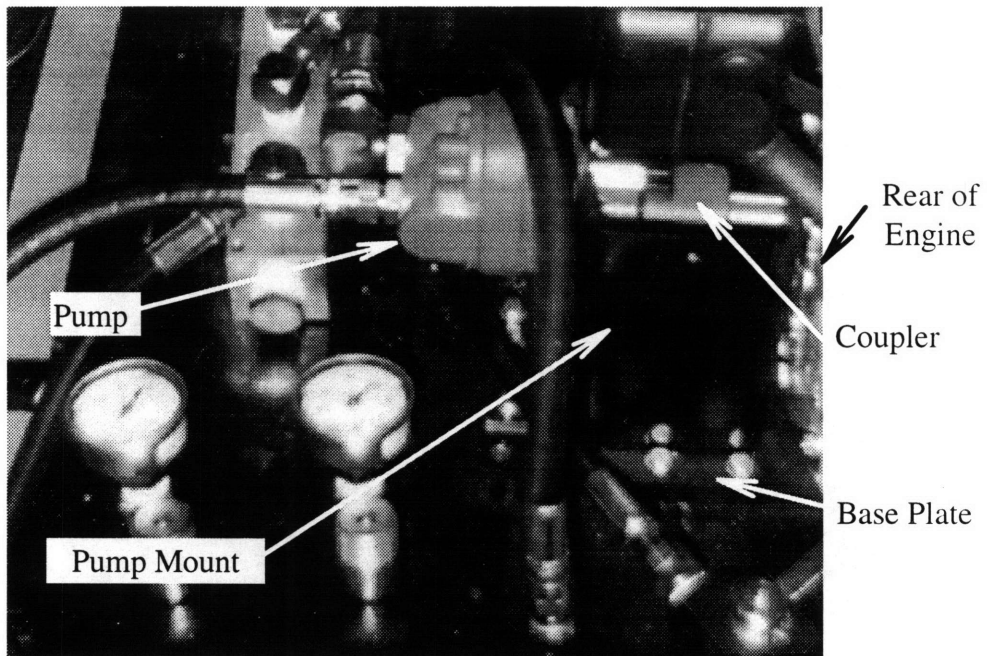

Figure 6-3. 5 Close Up of Assembled Pump Drive

6.3.1.1 Physics

A brief explanation of the theory used to design the hydraulic system follows. Equations 6-3.1 and 6-3.2 express the motor torque and required flow rate as functions of system parameters.

$$T = \frac{p_m \times D_m}{2\pi} \quad \text{Equation 6-3. 1}$$

$$Q_m = D_m \times \omega_m \quad \text{Equation 6-3. 2}$$

where,

T	motor torque
Q_m	flow rate
p_m	pressure drop across motor
D_m	motor displacement
ω_m	motor speed

Using the equations above and the estimated power and speeds of the components, the displacement of the motors and pump were calculated.

6.3.1.2 Material

The hoses, valves, and other standard items used to build the hydraulic circuit will not be discussed. Mounting of the fan drive and its components will not be covered here as they are discussed in section 6.2. Mounting of the auger motor is evident as shown in Figure 6-3.2. The mount for the auger motor, was made from a piece of aluminum angle. The base plate upon

which the engine and motor mount were placed was made from $\frac{3}{4}$ " thick HRS plate. The pump mount was made from a piece of 5"x7"x $\frac{3}{8}$ " thick steel tubing. The two brackets holding the pump mount to the base plate were made from aluminum angle.

6.3.1.3 Special Requirements

The coupler used to transfer power from the engine to the pump was rated for a maximum shaft off center condition of 0.010 inches and 1.0° of angular misalignment. To insure that the pump shaft and engine shaft would line up correctly, the base plate was ground flat, and the mounting surface of the pump mount made perpendicular to the base. Vertical and horizontal movement of the pump relative to the pump mount was allowed by drilling the mounting holes oversized.

Assuming the engine shaft was parallel to its base (and it was), there needed to be less than a 1.0° angular misalignment between the pump and engine shafts. This angle acting over the distance from pump mounting surface to engine shaft (approximately three inches) would yield a shaft offset of 0.010 inches, the maximum allowed by the coupler spider. To be on the safe side, the allowable deviation from perpendicular for the pump mount surface and the base plate was set at roughly 0.75 degrees.

6.3.2 Machining

6.3.2.1 Fixturing/Setup/Approach

Base Plate

The $\frac{3}{4}$ " thick steel plate was cut to near size ($15\frac{3}{4}$ " x 9") on a band saw, and the edges cleaned up with a horizontal mill. Next, the two main surfaces were ground flat in a vertical surface grinder. As this plate was to be drilled with twenty-eight holes (later realized too many), a vertical mill with digital readout was used to locate hole position. The partially finished plate is shown on the carriage of a mill in Figure 6-3.6.

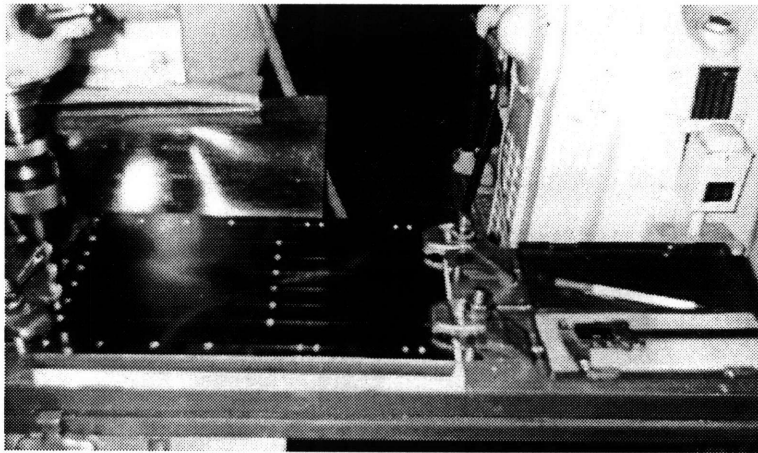

Figure 6-3. 6 Finished Motor Base Plate

Pump Mount



Figure 6-3. 7 Pump Mount Tubing After Surface Grind

The tubing for the pump mount was cut to size, then the large flats (see Figure 6-3.7) were ground on a vertical surface grinder. The piece was removed, and the edges cleaned with a horizontal mill. Next, the mount was "blued-up," and locations for features marked with a height gauge. The "U" shaped grooves in each flat were cut on a band saw, then cleaned on a vertical mill. The bottom holes of the mount were drilled on a vertical mill as shown in Figure 6-3.8.

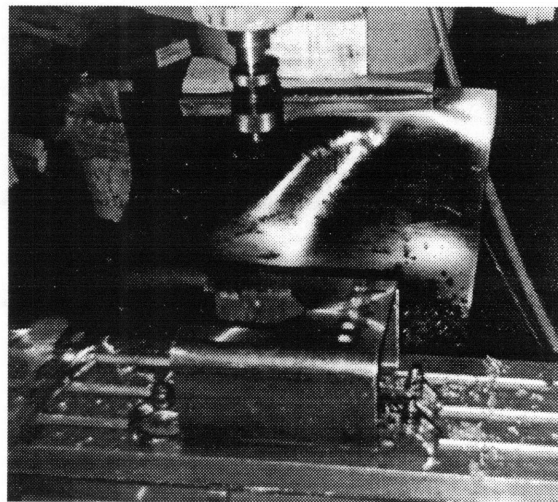

Figure 6-3. 8 Finished Pump Mount

Pump Mount Brackets

Two pieces of aluminum angle were cut to near size on a band saw. The pieces were then mounted in a vice on the carriage of a mill. The mill was used to clean the cut edges, then make the sides of the brackets perpendicular. Last, bolt holes for fastening the pump mount and base plate were drilled.

6.3.2.2 Problems

There were problems milling, drilling, and grinding the square tubing used to make the pump mount. The tubular structure of the mount would vibrate when machined. The fixturing used in the machining of the 6"x6" piece of square tubing (see section 6.2) was used to hold the tube, but helped little.

The base plate required twenty-eight holes (for mounting the pump, motor, and the plate to the frame.) If the material were aluminum, this would not have been a problem, however, the plate was made of steel. When a hole was being drilled, the bit would require lubrication every two to three seconds. If not done, the bit would become dull after four or five holes. Lubrication of the bit added time to the tasks of drilling and clean up.

During grinding, the pump mount was held in place by a magnetic chuck. However, preventing the piece from moving during grinding was difficult, so the tubing was reinforced by placing metal blocks on its sides. The blocks helped hold the tubing in place, but did little to stop the vibration. To minimize vibration, the feed rate into the work piece was kept below 0.005 inches per minute. The grinding of the pump mount surfaces took close to one hour as the plates surfaces were bowed in by approximately 0.250 inches.

6.3.2.3 Time

Task	Machining Time		Set Up	Misc.
	<u>Planned</u>	<u>Actual</u>		
Engine Base Plate	5.00	7.00	1.00	0.00
Pump Mount	5.00	10.00	1.00	0.00
Pump Mount Brackets	1.50	2.00	0.25	0.00
Σ=	11.50	21.25	2.25	0.00
Comparison:	11.50	21.25		

Major discrepancies between the planned and actual times are discussed below.

Engine Base Plate

Time spent lubricating drill bit in between "pecks" at the work piece along with clean up of the work area (thrice) made up a substantial portion of the difference. Grinding the plate was also difficult as the large surface area in contact with the grinding wheel generated a lot of heat. To prevent this, the feed rate of the grinding wheel was reduced to approximately 0.002 inches per minute.

Pump Mount

Most of the delay was due to vibration and lubrication problems as discussed previously. The problem became markedly worse after the "U" shaped groove was cut in the tubing. In doing so, the stiffness of the piece was decreased. This resulted in vibration which could only be eliminated by taking light passes (approximately 0.003 to 0.008 inches.)

6.3.3 Production Model

6.3.3.1 Design

- The hydraulic system of a production model* would be different from that of the prototype. The likely circuit is shown in Figure 6-3.9.

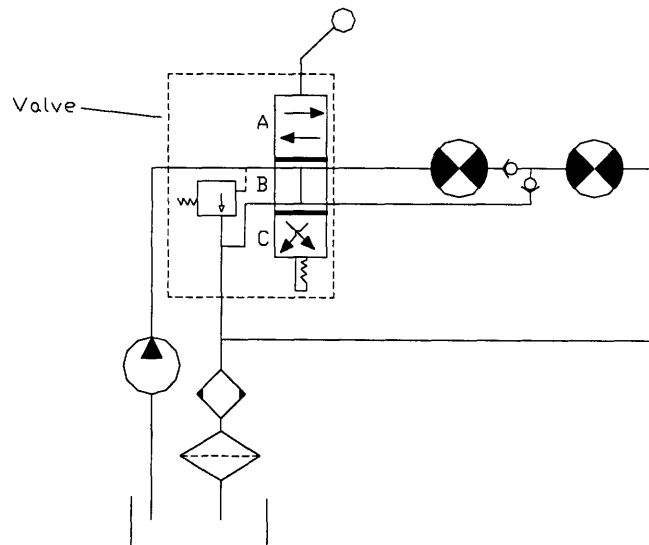

Figure 6-3. 9 Hydraulic Circuit For Production Model of Debris Cleaner

* Hydraulic system designed by Raymond McDonald, Director of Engineering, Ingersoll.

The awkward "on/off" ball valve control was eliminated. In its place, a motor spool control valve would be used. The same operation as in the prototype would be achieved, but with a simpler circuit:

- Position A, operation of auger and fan at set speed
 - Position B, off (allows fluid to dump to tank)
 - Position C is fan only, could be used for spot vacuuming with an auxiliary hose or when running a chipper/shredder
- The design used to couple the engine to the pump worked very well. A variation of this design with cast components would be used in the prototype.
- As covered in section 6.1, the chain drive of the auger would be changed to a belt drive to avoid wear and maintenance problems. The reader should note that this is how components of similar cleaners are driven.
- The manner in which the fan shaft was driven would be essentially the same, except the fan motor support would be replaced by an "outrigger." This is a device which performs essentially the same function as the system shown in Figure 6-2.1.

6.3.3.2 Necessary Material

To mass produce this assembly, the following materials or components would be used:

<u>Component</u>	<u>Material/Type</u>	<u>Process</u>	<u>Manufacture/Purchase</u>
Fan Motor	High Pressure	-----	Purchase
Auger Motor	High Pressure	-----	Purchase
Motor Spool Control Valve	Standard	-----	Purchase
Check Valves (2)	Standard	-----	Purchase
Filter	Standard	-----	Purchase
Pump	Variable Displacement	-----	Purchase
Reservoir	Standard	-----	Purchase
Heat Exchanger	Custom Made	-----	Purchase
Auger Drive Sheaves	Standard	-----	Purchase
Auger Mount (to hopper)	Aluminum or Steel	Make From Angle	Manufacture
Pump Mount	Casting/Tubing	Sand Cast/ Milled	Manufacture
Engine Base Plate	Casting/Boiler Plate	Sand Cast/ HRS	Manufacture
Idler Pulley	Standard	-----	Purchase
Belt	Standard	-----	Purchase
Junction Block	Standard	-----	Purchase

6.3.3.3 General Discussion

Itemized changes to the prototype follow:

- High pressure pumps and motors are less expensive than lower pressure components.

The running pressure of the new system should be high, approximately 2500 to 3000 psi, so that less expensive components could be used.

- A heat exchanger may need to be added to the hydraulic reservoir. This was pointed out by Raymond McDonald of Ingersoll Incorporated.

- The hydraulic manifolds for the prototype cost approximately \$250 dollars each. Either less expensive manifolds, or some type of inexpensive junction block would be needed.

- There would be three different variations of the power system of the debris cleaner. The first would use an on-board power source as was done in the prototype, the second would be powered by the hydraulic PTO of a tractor, and the third would use a gear pump powered by the PTO shaft of the tractor. Each version would start out essentially the same during production. When it came time to install the drive system of the cleaner, the single production line would split into three, each dedicated to one of the three types of drive systems.

- The parts of the hydraulic system discussed in this section would be purchased, with the exception of the pump mount, auger motor mount, and engine base plate. The manufacture or purchase of parts which are not discussed in this section (e.g. fan drive) are covered in the appropriate sections of this chapter.

6.4 Hopper

6.4.1 Design

In this design, conceived by Professor Slocum, the edges of the body and side panels would be folded, then slid over the ends of the body and welded as shown below. The result

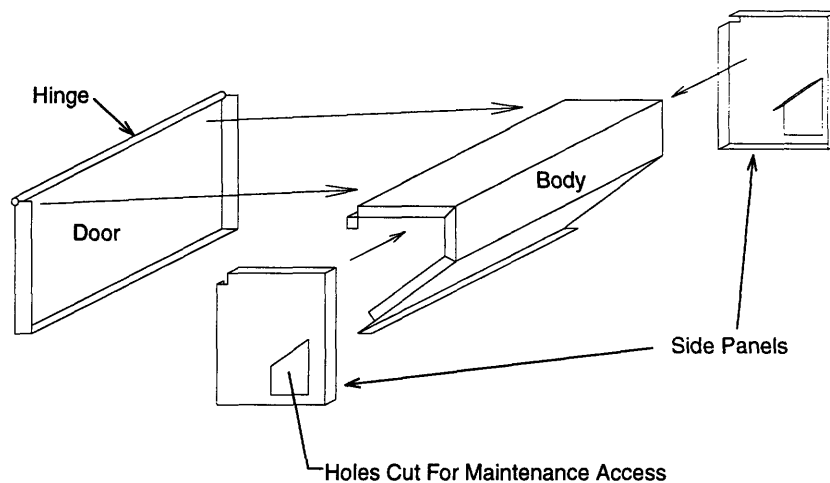

Figure 6-4. 1 Design of Prototype Hopper

would be essentially a rigid angle frame at the intersections of the body and side panels (see Figure 6-4.2.) The door would be attached to the rear of the hopper via a continuous hinge. The

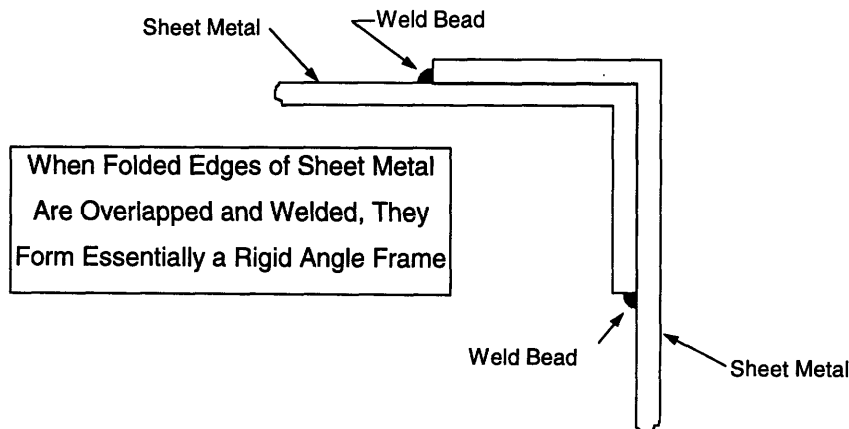

Figure 6-4. 2 Illustration of Formed Frame

edges of the door would be folded similarly to the side panels so that the folded edges would slide over the edges of the side panels like a lid on a box.

6.4.1.1 Features of Design

Welding would be easier as the folded edges of the components lie flush at their contacting surfaces. Lap joints such as these are much easier to weld than the “T” joints one would have to weld in a traditional frame. Assembly would be easy as the hopper would hold itself together, thus eliminating the need for either an extra operator or extra fixturing. Also, as the edges of the hopper panels would overlap, the hopper would be self sealing. This would

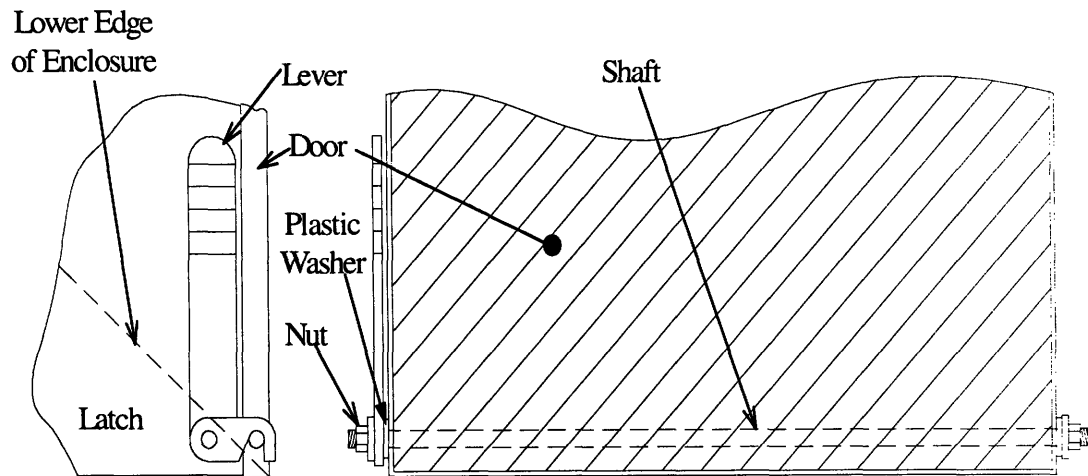

Figure 6-4. 3 Hopper Door Latch Assembly

permit stitch welding of the components as continuous welds would not needed to seal the enclosure.

Figure 6-4.3 shows the assembly used to open and close the hopper door. With the lever in the closed position, the latches would hold pegs which attached to the edges of the door.

When the lever was rotated counterclockwise, the latches (attached to the shaft) would rotate

also. At a set angle of rotation, the latches would release the pegs and the lower edge of the lever would kick the pegs away from the hopper. This would prevent one edge of the hopper door from opening part way, while the opposite end wedged on the other side of the hopper. Once the pegs were released, the hopper door would open under pressure from its contents. Returning the latches over the pegs would lock the door in place. The shaft would be held in position by friction between the lever and a polymer washer located between the lever and the side of the hopper.

6.4.1.2 Material and Characteristics Pertinent to Design

Hopper

Originally, the hopper was to be fabricated from 14 gauge sheet metal. However, the shop at which the hopper was made, Metal Smiths Incorporated, did not have this gauge in stock. The most similar material available was 10 gauge steel. Also, the hopper was originally designed to be 60 inches wide. Adding two inches for the bent flaps on each side would yield a required dimension of 64 inches for the blank. The widest material available was 60 inches, so the width of the hopper body was shortened to 58 inches, and the flaps shortened to 1 inch each.

As the body was to be slid inside of the side panels, it was sized by specifying maximum dimensions at its outer surfaces. The side panels were dimensioned using minimum dimensions between inner surfaces. The dimensions of the body and side panels were matched so that the inner dimension of the side panels would equal the corresponding outer dimension of the body.

Latch System

The major components of the hopper latch assembly were the shaft and the latches. The shaft was made from a $\frac{5}{8}$ inch rod of low carbon steel. The latches were originally designed to be made from $\frac{3}{8}$ " low carbon steel plate, however, the supplier mistakenly made them from $\frac{1}{8}$ " thick steel.

6.4.2 Machining

6.4.2.1 Approach and Planning

The first step was to build the half scale model shown in Figure 6-4.4. This was done as a check to make sure that the pieces (which were modeled) would fit together properly.

The prototype hopper was built at Metal Smiths Incorporated. Before starting, the author and shop owner held a design review. During the review, suggestions for improvement in material, size, and shape were given. Ways to produce the hopper in large quantities (see section 6.4.3) were also discussed.

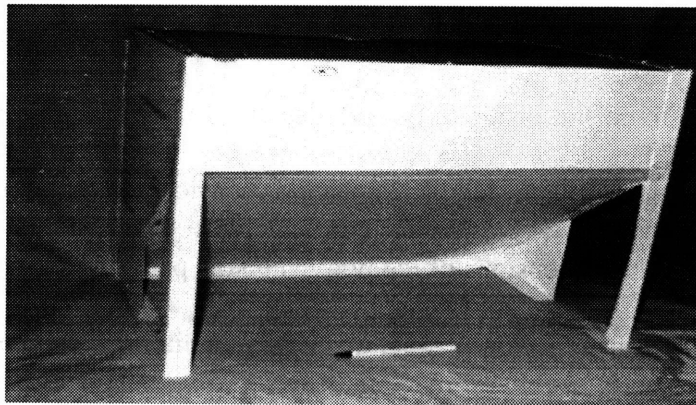

Figure 6-4. 4 Half Scale Model of Prototype Hopper

The design of the welded joints was changed. Originally, to provide strength and minimize the number of cuts required, the flaps were to overlap. In the final design the edges of the flaps met flush instead of overlapping. This change was made because the old design was just as easy to make and resulted in a flat surface to which the side panels could be welded.

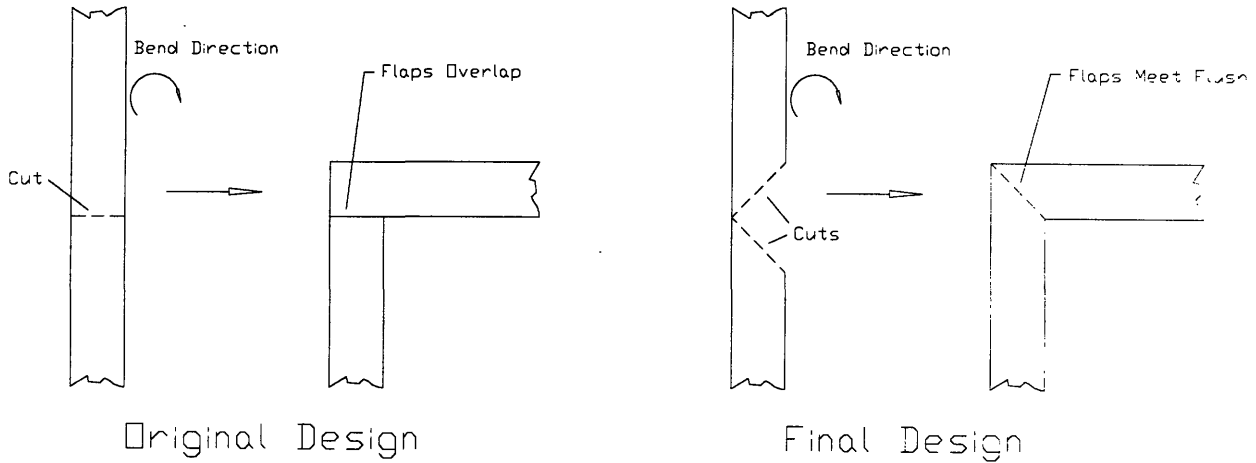

Figure 6-4. 5 Comparison of Old and New Flap Design

6.4.2.2 Construction

Hopper Body

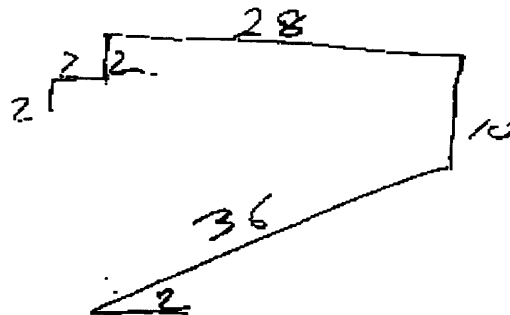

Figure 6-4. 6 Desired Finished Size of Hopper Body (Side View)

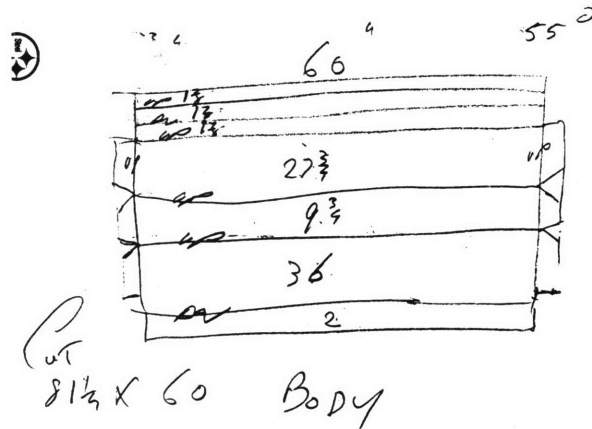

Figure 6-4. 7 Final Shop Layout of Body Blank

The blank was cut from a 60" x 82" sheet of 10 gauge steel. Figures 6-4.6 and 6-4.7 show the shop sketches used to size the blank for the body. Note that dimensions of the two figures seem to conflict. The reason for this was that Figure 6-4.6 shows the maximum outside dimensions of the hopper, while Figure 6-4.7 shows the locations of the interior bend lines.

The dimensions can be reconciled if the thickness of the steel sheet (approximately $\frac{1}{8}$ ") is taken into account. The increase in dimension due to the thickness of the metal is added at each bend. As there are two bends, the dimension of 10 inches is $9\frac{3}{4}" + 2(\frac{1}{8}") = 10."$

The edges of the body flaps were cut using a plasma torch and straight edge. Next, the blank was moved to a press where the body was folded as shown in Figure 6-4.8.

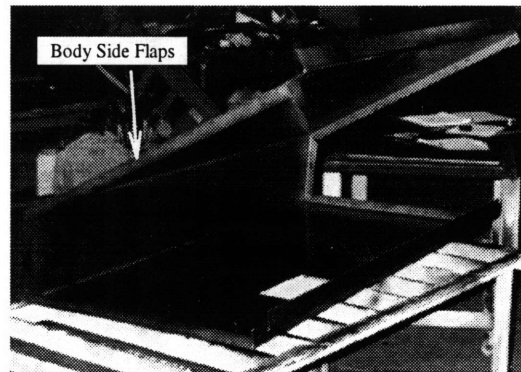

Figure 6-4. 8 Finished Hopper Body

Side Panels

The side panels were made from two 33" x 33" 10 gauge sheets of steel. The dimensions of the side panel were first drawn out (from the author's blueprints) in a sketch shown in Figure 6-4.9. A press with a 90° punch was used to cut the corners. The edges were then bent in a press

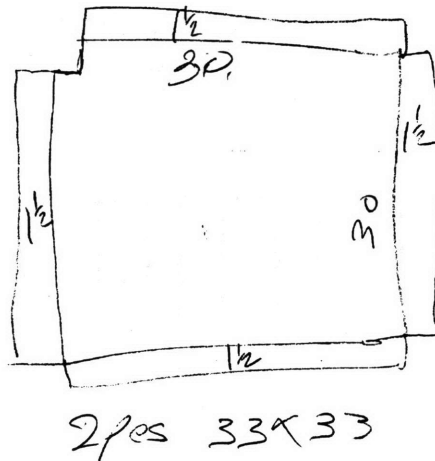

Figure 6-4. 9 Shop Sketch of Side Panels

to form the “box lid” shape of the panel. Then the panels were individually tack welded onto the end of the body as shown in Figure 6-4.10.

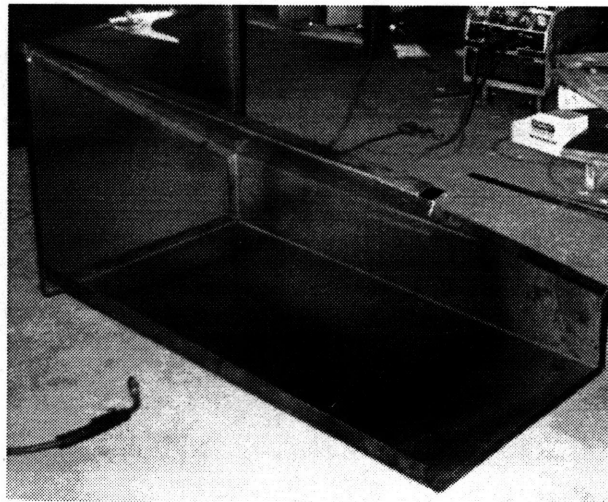

Figure 6-4. 10 Side Panel Attached to Body

Viewing Port, Hopper Exhaust Port, Fan Exhaust Port, and Access Panel Cut Outs

The holes cut for the view port, exhaust port, and access ports can be seen in Figures 6-4.11 and 6-4.12. Guide lines for the holes were drawn on the hopper with black marker, then cut

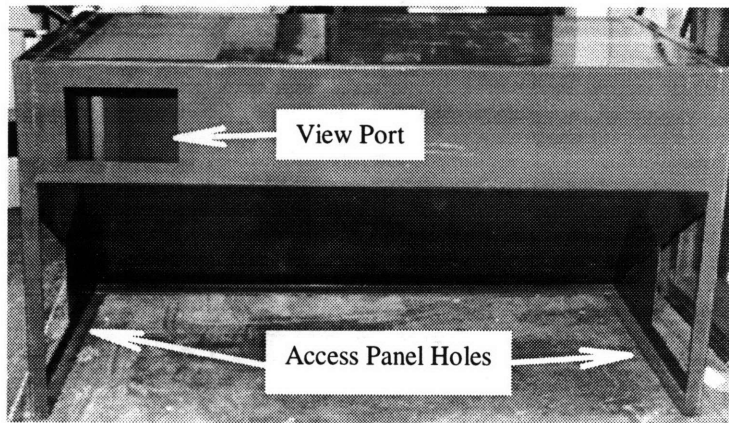

Figure 6-4. 11 Hopper With Side Panel Access Holes and View Port

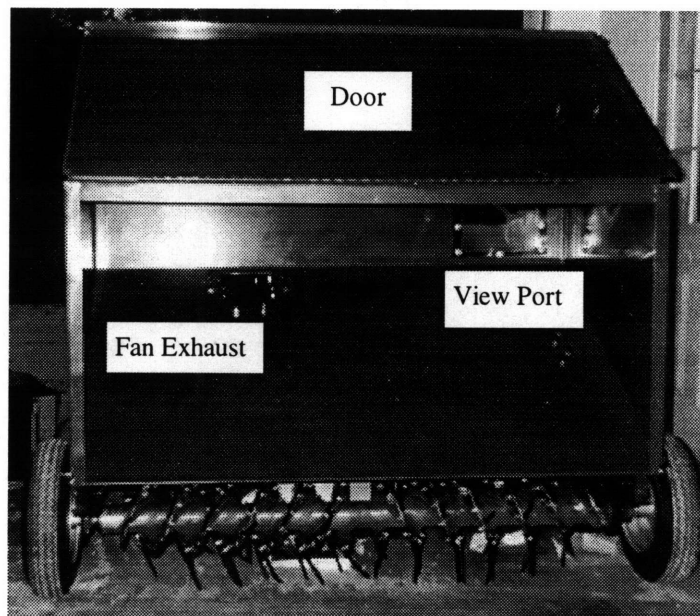

Figure 6-4. 12 Hopper With Fan Exhaust and View Port

using a straight edge and plasma torch. Perforated metal was welded over the exhaust port to act as a filter for exiting debris.

Hopper Door

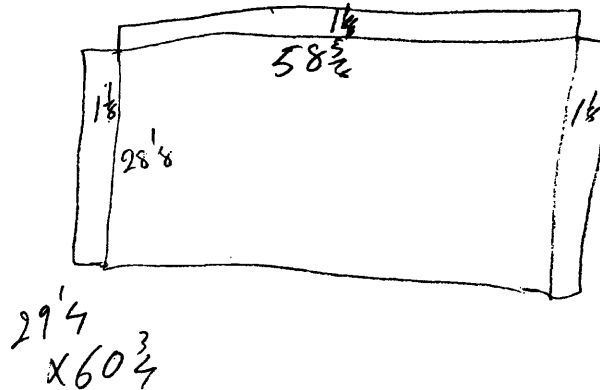

Figure 6-4. 13 Shop Drawing of Hopper Door

The door was sized after the hopper was built. Measurements for the door are shown in Figure 6-4.13. The blank was cut from a $60\frac{7}{8}$ " x $29\frac{1}{4}$ " 10 gauge sheet of steel. The corners were cut out using a plasma torch and the edges were bent to shape in the same press as the side panels. The door was attached to the hopper using a 48inch long continuous hinge. Afterwards, the hopper was washed with denatured alcohol and painted.

Hopper Door Latch

The shaft for the door latch was turned on a lathe, then flats were milled on the ends of the shaft. One latch was welded to one end of the shaft, the other was left free to slide on the opposite end. This was done so that the shaft could be slid in one side of the hopper, the free latch slid on the other end of the shaft, then a bolt tightened on the latter end. Tightening the bolt

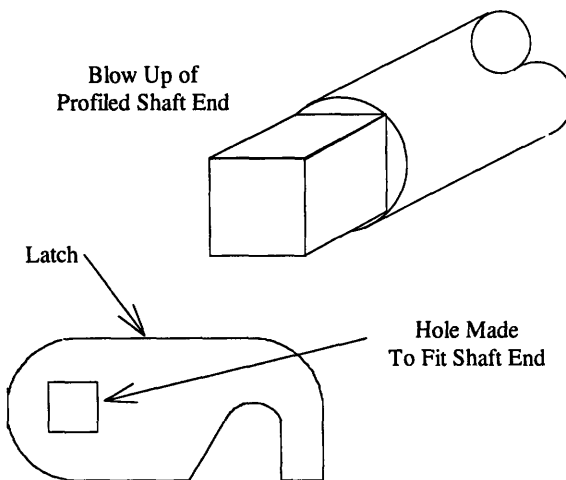

Figure 6-4. 14 Detail of Hopper Latch Shaft End and Latch

put pressure on the polymer washer located between the lever and side of the hopper, which in turn held the assembly in place by friction.

6.4.2.3 Problems

The shop responsible for supplying the latches made them from 1/8" steel sheet instead of the 3/8" as specified. The latches took three weeks to deliver, so the author decided to use them and change the (already mad) latch shaft to fit.

6.4.2.4 Time to Complete Assembly

Task	Machining Time		Set Up	Misc.
	Planned	Actual		
Make Hopper	5.00	3.00	0.50	0.00
Paint Hopper	1.00	1.50	1.0	1.00
Insert View Port	1.00	1.00	0.00	0.00
Machine Latch Shaft	1.50	4.00	0.75	0.00
Drill/Grind Hopper For Shaft	1.00	1.00	0.00	0.00
Drill and Grind Lever	0.50	0.50	0.25	0.00
Σ=	10.00	11.00	2.50	1.00
Comparison:	10.00	14.50		

6.4.3 Production Model

6.4.3.1 Design and Material

Design

As discussed in section 5.5.2.3, the type of hopper used in the prototype is superior to the traditional steel frame and sheet metal hopper. Less material, time, tooling, and man power are needed for assembly. Approximately the same amount of sheet metal would be used, but the traditional frame would require additional channel or square tubing. In addition, less fixturing is needed for welding the folded sheet hopper because the side panels and door hold themselves in place without fixturing. Figure 6-4.2 shows the time and labor needed to manufacture one of the hoppers. The information in the table was estimated with advice from Metal Smiths

Incorporated (a sheet metal fabricator,) and knowledge of Creative Processing's (a laser shop's) capabilities

Folded Sheet Metal Hopper 1 Person		Traditional Hopper 2 People	
<u>Operation</u>	<u>Time, min.</u>	<u>Operation</u>	<u>Time, min.</u>
Laser Cut Sheet Metal	8	Cut Sheet Metal	10
Bend Sheet Metal	25	Cut Frame Material	10
Assemble	5	Assemble, Weld Frame	20
Stitch Weld	10	Continuous Weld on Sides	15
$\Sigma =$	48	$\Sigma =$	55

Material

The design of the hopper would change little from that of the prototype. However, instead of using 10 gauge sheet metal, aluminum sheet of approximately the same thickness would be used. This would reduce the weight of the hopper by 66 percent and allow for a smaller axle to be used. Blow molding fiber glass or some sort of plastic was considered, but as explained in chapter 5, was not used for safety reasons.

6.4.3.2 Necessary Materials/Components

To basic items needed to produce the hopper are listed in Table 6-4.3. Note that painting of most components was assumed.

Table 6-4.3 Components for Production Version of Hopper

<u>Component</u>	<u>Material</u>	<u>Process</u>	<u>Additional</u>
Sheet	Aluminum Sheet	Laser Cut, Tack Weld	10 gauge (~ 47 ft ²)
Latch Shaft	1/2" HRS Rod	Turn, Mill, Thread Ends	-----
Latches	2x3x3/8" Steel Plate	Profiles Milled	-----
Continuous Hinge	-----	Weld to Hopper	Purchased
Wire	1/16" Coated Cable	Cut to Length	Purchase
Lever	1 inch thin walled pipe	Cut to Length and Weld	-----
Handle	Rubber	-----	Buy To Fit Lever

6.4.3.3 General Discussion

After consultation with Metal Smiths Incorporated, it was decided that the best way to manufacture a hopper would be to have a laser shop cut the patterns from sheet metal. This is a common practice for companies such as Harvey- Davidson and Huffly which make many parts out of thin metal.

Creative processing of Chagrin Falls, Ohio, and Cory Laser of Cory, Pennsylvania, typically charge \$120 to \$150 dollars per hour for laser cutting. A 3000 kW laser (common for

shops to have) with two axes should be able to cut each patterns in less than two minutes.

Figuring four patterns per hopper at roughly \$150 per hour, this comes to \$20 dollars per hopper (on the high end.) Bending the cut blanks could be done with tooling common to most sheet metal shops.

Welding of the hopper would be done much the same as in the prototype. Stitch welds of approximately four inches in length would be spaced about ten inches apart. Afterwards, the hopper would be cleaned in a booth, then moved on a conveyor to an adjacent booth where it would be painted.

The latching system would remain the same, except for an added pull wire. Instead of using a lever as the primary means of opening the hopper, a wire or rope would be run from the front of the machine to the lever. With this feature, the operator could pull the wire and empty the hopper without traveling to the rear of the machine.

6.5 Frame

6.5.1 Design

6.5.1.1 Design

The prototype frame consisted of a piece of $\frac{3}{4}$ " plywood (platform, approximately

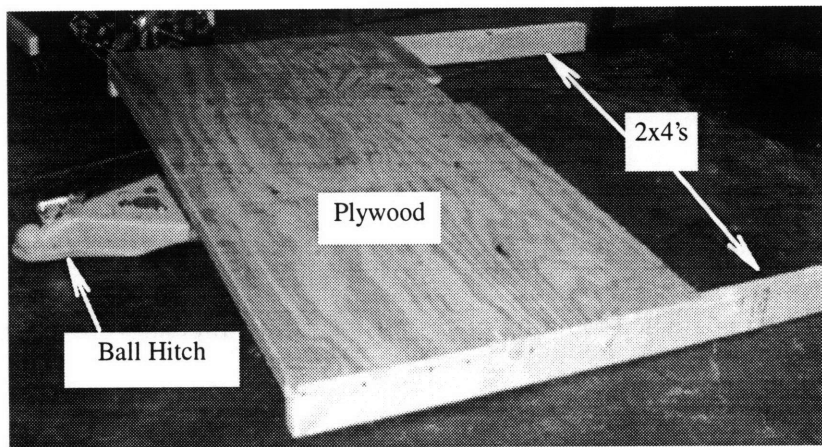

Figure 6-5. 2 Prototype Frame

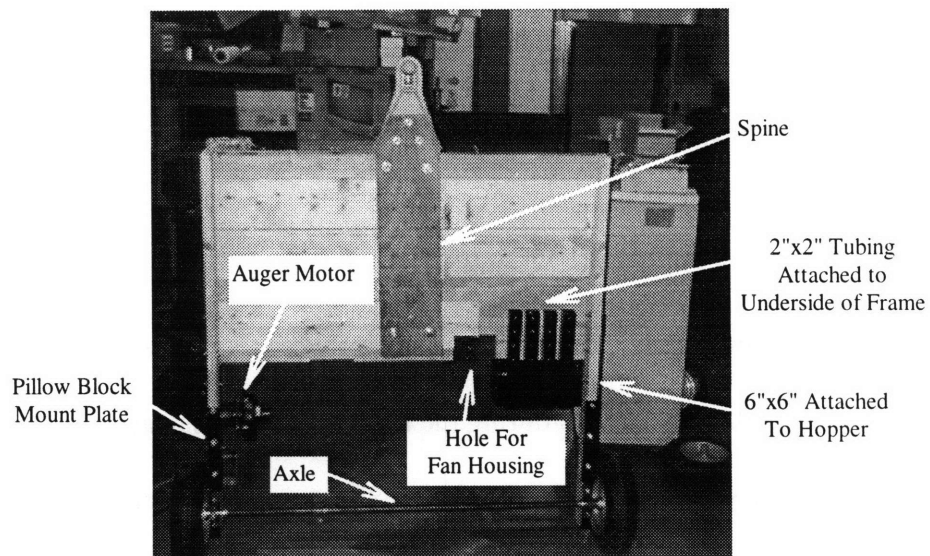

Figure 6-5. 1 "Belly" View of Cleaner Frame.

60"x30") upon which various components of the machine were to mount. Supporting the plywood were two 2x4's (side supports) which extended beyond the edge of the plywood. The hopper was designed to mount upon these lengths, and pillow blocks designed to mount below (see Figure 6-5.2.) Strips of $\frac{1}{4}$ " thick steel (pillow block mounts) were placed in-between the pillow blocks and the wood frame to prevent the pillow blocks from digging into the wood. The hitch was connected to a 2x8 (spine) which was mounted below the cross supports and in the middle of the frame.

6.5.1.2 Material

Wood was used because it would be easy to modify if design changes in other components were needed. The mounting plates for the pillow blocks were made from $\frac{1}{4}$ " steel plate.

6.5.2 Machining

6.5.2.1 Fixturing/Setup/Approach

All pieces were cut to size, assembled using wood glue, then fastened together with wood screws. The hitch and pillow block mounting plates were then added. Holes for mounting the hopper and other parts were drilled during the mounting of those parts. To make the pillow block mounting plates, the steel was cut to size, then holes were drilled for fasteners. When finished, the frame was spray painted black.

6.5.2.2 Problems

There were no problems in building the frame.

6.5.2.3 Time

Table 6-5. 1 Time to Machine Frame Components (in hours)

Task	Machining Time		Set Up	Misc.
	<u>Planned</u>	<u>Actual</u>		
Cross Supports (2x8)	0.15	0.15	0.00	0.00
Front Support (2x4)	0.15	0.15	0.00	0.00
Platform (plywood)	0.25	0.25	0.00	0.00
Rear Support (2x8)	0.15	0.15	0.00	0.00
Side Supports (2x4)	0.15	0.15	0.00	0.00
Spine (2x8)	0.15	0.15	0.00	0.00
Upper Frame Support	0.15	0.15	0.00	0.00
Pillow Block Mount Plate	1.50	1.50	0.25	0.00
Drilling Mounting Components	1.00	1.00	0.00	0.00
$\Sigma=$	3.65	3.65	0.25	0.0
Comparison:	3.65	3.90		

6.5.3 Production Model

6.5.3.1 Design and General Discussion

The frame for a production model would be built from steel channel or tubing, approximately 1.50"x1.50." This decision was made after discussing the application with Metal Smiths Incorporated. A sketch of the frame is shown in Figure 6-5.3. The on-board components would be moved under the angled edge of the hopper to make a shorter frame. This was desirable as a shorter distance from hitch to axle (for pull behind implements) would result in a smaller turning radius.

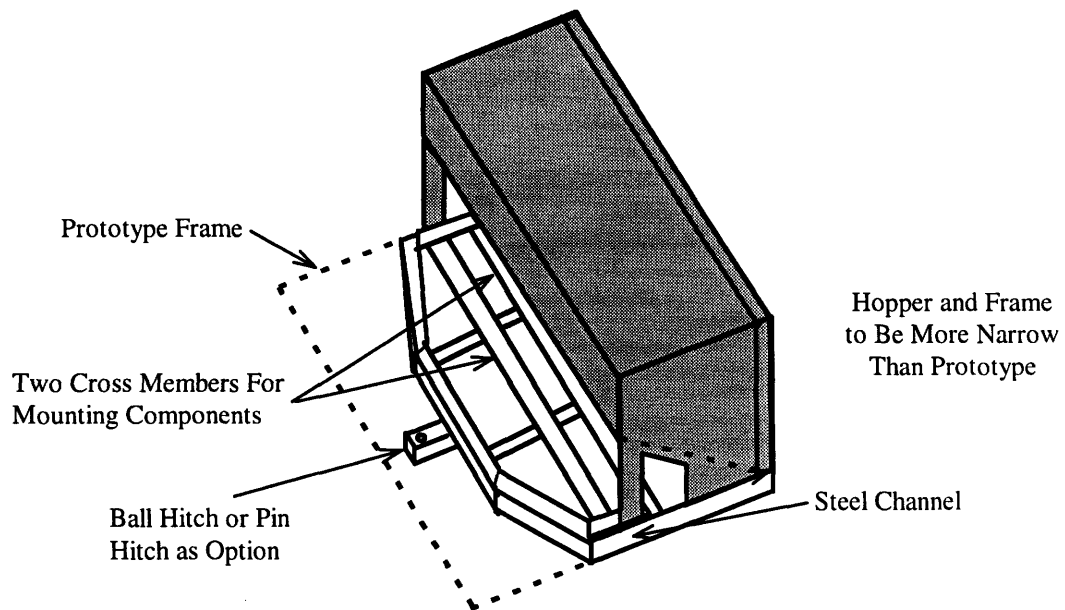

Figure 6-5. 3 Illustration of Production Frame

6.5.3.2 Necessary Materials/Components

The basic items needed to produce the hopper are listed in Table 6-5.2. Note that painting of most components was assumed.

Table 6-5. 2 Components For Production Version of Frame

<u>Component</u>	<u>Material</u>	<u>Process</u>	<u>Additional</u>
Tubing or Channel	Steel	Cut and Weld	-----
Hitch	Pin or Ball Hitch	Weld to Frame	-----

6.6 Finished Prototype

Approximately 145 hours of machining, including fifteen hours of assembly, were needed to make the machine.



Figure 6-6. 1 Finished Prototype at Test Site

6.7 Plant Layout (Rough Cut)

A rough first-cut of a manufacturing plant for production of the debris cleaner is shown below in Figure 6-7.1.

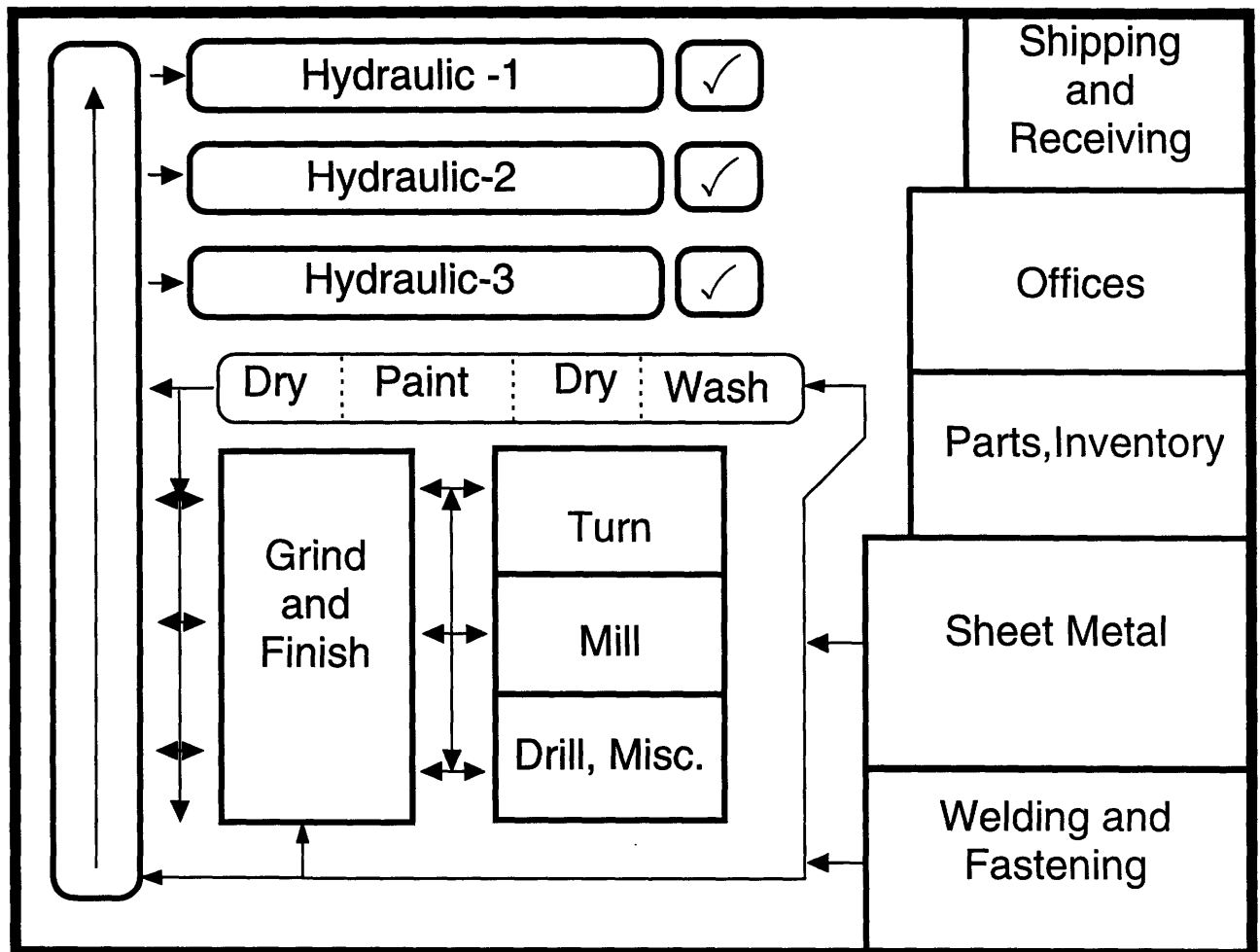

Figure 6-7. 1 Rough Plant Layout

The plant was set up so that finished cleaners and incoming parts were located close to the loading docks (at shipping and receiving.) Finished cleaners not shipped immediately after the line check would be stored in an adjacent building/room (not shown.)

Parts would be moved between machining centers on pallets using a fork lift for long hauls (such as from grinding to paint), and hand trucks for the short hops between machining centers. To minimize traffic, the machining centers are located in close proximity with only an isle separating them.

The machining centers were set up so that most pieces could flow from rough to finished (right to left.) For items which would require grinding before other operations, parts could flow back from the appropriate machining center. This would be the case for items such as the engine base plate and those needing painting. The number of paint lines shown would depend upon the cycle time of the painting process. In the figure, one line is shown, but the author could envision two paint lines for the hopper and possibly a line dedicated for all other items. Paint booth(s) would be set up so that once the hopper was dry, it could be dropped directly on the chassis at the assembly line. Flow on the assembly line is shown on the following page in Figure 6-7.2.

Ideally, one would now sit down and perform cost analyses on all of the components to determine if the rough cut estimates (in the production discussions of the following sections) were correct. For example, it may end up that some of the parts which were "pegged" to be made, may be more cost efficient to purchase. Then based upon these analyses, a justification analysis would be performed to estimate ROI using cost of plant, equipment, labor, and other factors. If the ROI would meet the minimum requirement (of a company or investors) then money would be allocated. If not, then the analysis would be redone to find ways to cut cost and increase the ROI. Note, that ROI for some companies is as high as 18 percent.

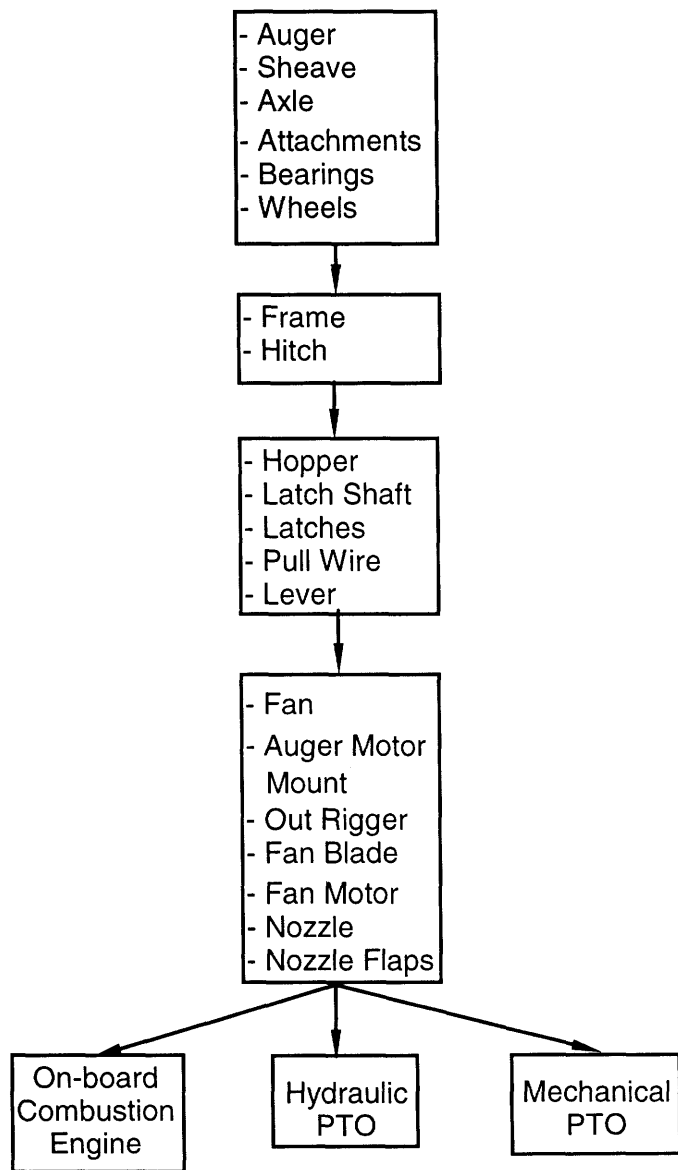

Figure 6-7.2 Rough Order of Assembly

Chapter 7 Prototype Evaluation

7.1 Parameters of Interest

Testing of the prototype was done to achieve the following goals.

- Proof of concept
- Find the correct operation parameters
- Measure power consumption and compare with model prediction
- Identify areas to be improved

Each of these will be discussed after the background of the test is presented.

7.2 Set up

Test Set Up

Twenty runs were made on three separate days at the residence of Professor Slocum. A debris field was made by raking leaves into a path approximately eight feet wide, twenty feet long, and three inches deep. The path was chosen so that cleaning would start on a level surface, progress over depressions and high spots midway through, then finish on a relatively flat length. The depressions and high spots in the lawn varied from the average height of the surface by approximately three inches.

Debris

Oak leaves were used as they are one of the hardest types of leaves to collect. The reason for the difficulty, as described by Raymond McDonald, Director of Engineering at Ingersoll, was that oak leaves are heavy, making them difficult to capture. Collection is further complicated when the leaves are damp, as they are heavier, stick together, and become slippery (to things other than themselves.)

7.3 Proof of Concept

Questions

For the author, four questions needed to be answered.

1. Would the compliant attachments damage the lawn?
2. Would the auger convey the debris?
3. Would the hydraulic drive function as needed?
4. Would it clean effectively?

Answers

1. Yes, after several passes over the same portion of lawn, the surface was not noticeably damaged. On each run, the fingers dislodged the debris and delivered them to the auger. Actually, they had a great deal to do with the transport of the leaves toward the nozzle, as explained in the next answer.

2. The auger helped to convey the leaves, but not in the manner it was designed. The original thought was that the auger would convey the leaves as though they were a fluid. Observation of the auger during the test runs showed that the transport happened in an entirely different way. Although some of the leaves were transported by the auger flighting, the compliant attachments were chiefly responsible for the transport.

As the attachments engaged the surface (ground, grass, or debris,) they were bent against the flighting of the auger. When the attachments were loosed from the surface, they flicked away from the auger flighting, kicking the debris toward the center of the machine. The process is illustrated in the following figure.

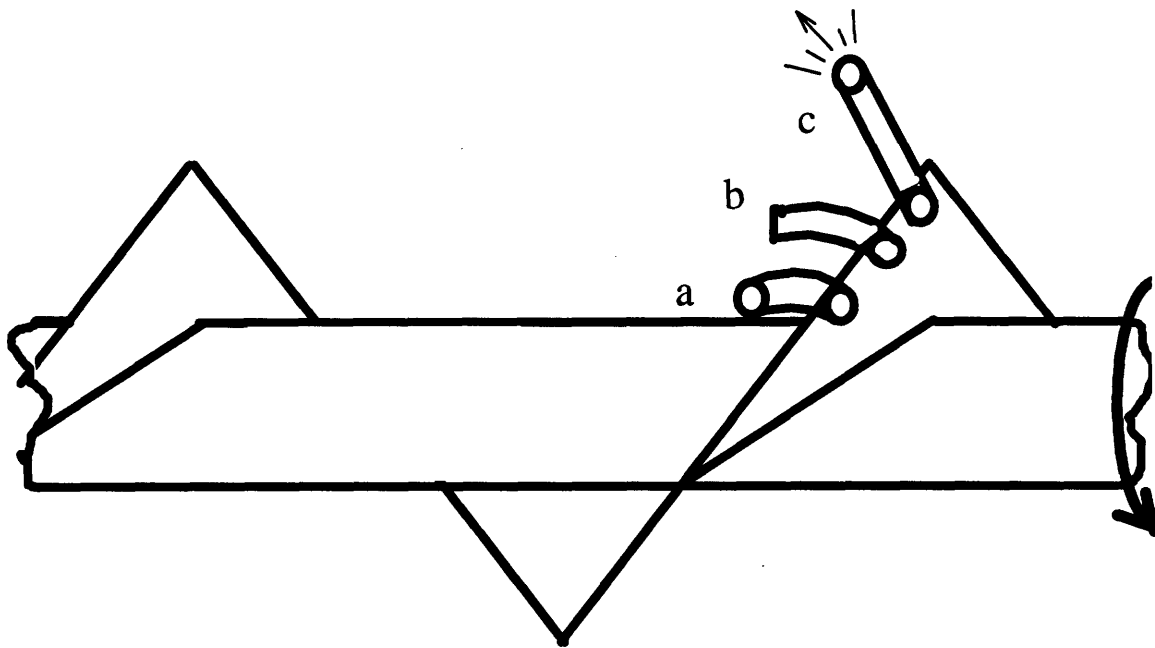

Figure 7-3. 1 Illustration of Debris Conveyance by Attachments

We begin at point a, where the attachment is bent against the auger flight upon contact with the ground. As the auger rotates, the attachment moves to point b, where it is at its maximum deflection. At point c, the attachment snaps free from the ground and flicks debris away from the auger flight toward the center of the machine.

3. The hydraulic system worked as needed. However, running the system was somewhat awkward because the author had to set the engine speed to low, then open the ball valve, then adjust the engine again (to adjust flow.) Raymond McDonald of Ingersoll suggested that a variable displacement pump be used in conjunction with a motor spool control valve. This would allow the operator to start the engine, set it to a particular speed, then energize the system without touching the engine afterwards.

4. The cleaner was effective, but there were problems with the conveying rate of the auger. These will be discussed in more detail in the next section.

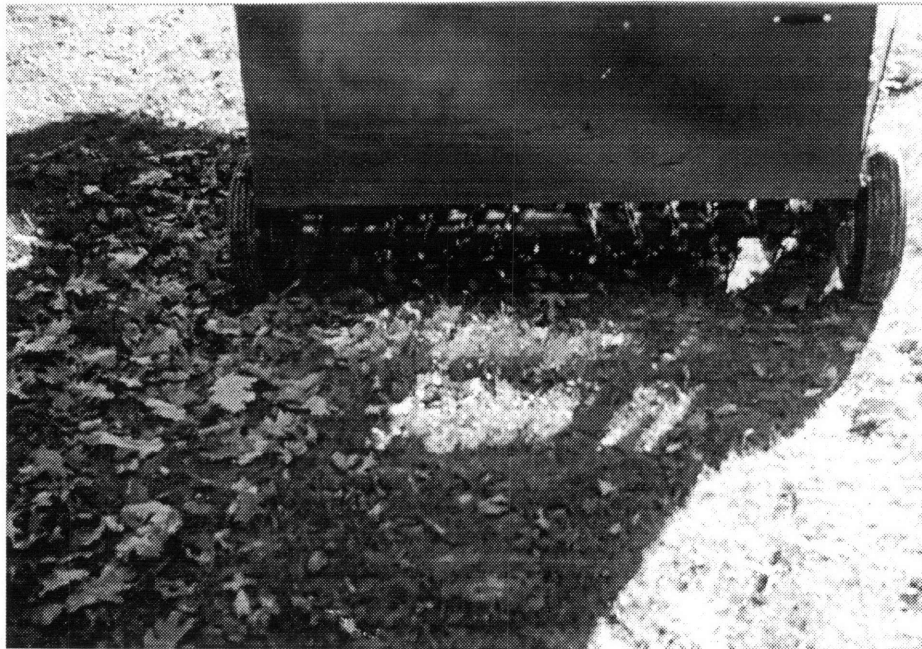

Figure 7-3. 2 Debris Cleaner At Work

7.4 Find the Correct Operation Parameters

For the fan to be effective, a speed of at least 2500 rpm was needed. Once this was determined, the fan was run at approximately 2500 rpm for the remainder of the tests. Effective auger speed depended on the ground speed of the machine and the thickness of leaf cover. Higher ground speed and/or density of debris meant that auger speed had to be increased. When tractor speed (approximately 2 miles per hour) and density of debris (normal lawn cover) were low, a speed of 120 rpm was adequate. When ground speed was high (approximately 4 to 5 miles per hour) and the debris cover was thick (approximately 2 inches of cover,) an auger speed of 200 rpm was needed. When the auger speed was set for the higher range (200 rpm) and the prototype was run at 2 mph over normal debris cover, cleaning was adequate. This meant the speed of the auger could be kept at 200 rpm for cleaning in-between the two extremes.

If the test was run beyond the upper extreme, the machine was not effective. The reason for this was that the conveying rate of the auger was insufficient. Increasing the auger speed to boost the conveying rate did not work. After debris accumulated to a certain height in front of the auger, it would be flung over the top. Increasing the conveying rate now meant changing the flighting of the auger, which was impossible as it was rigidly attached to the auger core. A trough was designed to enclose the rear of the auger, but was not tried as Raymond McDonald pointed out that this would be ineffective as a gap between the trough and ground (to prevent interference) would allow debris to escape.

7.5 Power Consumption

Tests were run with the machine cleaning thick debris at approximately 4 to 5 mph. Result of the measurements are shown in Table 7-5.1. Note that the values listed are those needed for satisfactory operation of the machine.

Run	Auger		Fan	
	<u>pressure, psi</u>	<u>speed, rpm</u>	<u>pressure, psi</u>	<u>speed, rpm</u>
	100	200	1200	2500
	<u>Auger Power, hp</u>		<u>Fan Power, hp</u>	
	0.11 (.08 kW)		13.9 (10.4 kW)	

The power consumption of the auger was far below the 1.19 hp predicted in section 5.1.6.3. The discrepancy is most likely due to the overestimated force used to calculate the resistance of the grass. Two pounds force (normal force) were assumed to act on 6 points of the auger, each point representing a place where attachments would touch the ground. A value of 1.0 for the resistive "coefficient of friction" between the grass and attachments was assumed (type of attachments were not know at the time,) realizing this would yield an overestimate. The resistance of the compliant attachments was actually much less than that assumed, thus requiring less power.

The power required to run the fan was close to that predicted by the model in section 5.2. The model estimated power consumption at 13.2 hp. The difference between the two could come from one or more of the following sources:

Fan efficiency- The efficiency for the Trac-Vac™ fan was not known. Typically, maximum fan efficiencies for paddle fans are approximately 60 percent. This value was used in the model.

Loss factors- Some loss factors were taken from graphs, other from literature recommendations of "ball park" estimates.

Density of debris- The density of the air-leaf mixture (appendix D) was a rough estimate.

Humidity/Temperature- The model did not account for humidity or temperature differences

7.6 Suggestions For Improvement

Changing the following would make for a better machine:

- The auger flighting only need extend from the ends of the auger to the edges of the nozzle. Standard radial brushes could be attached to the auger shaft behind the nozzle instead of the more expensive auger flighting.
- During testing, the rigid auger came close to bumps in the lawn. Raising the ground clearance from four to six inches would make for a safer machine.

- The turning radius allowed by the prototype did not permit the machine to turn and enter the debris field adjacent to the previously cleaned path. To decrease turning radius, the distance between the hitch and the axle of the machine should be decreased to the appropriate length.
- The fan did not shred the leaves as expected. A new fan assembly, perhaps with serrated attachments, would be needed to properly shred the debris.
- No provision had been made for assisting in raising and holding the prototype door. Originally, the author did not believe this would be important. However, this opinion quickly changed after the author had to repeatedly lift and hold the door of the hopper when dumping. To improve the design, either springs or pressurized cylinders should be used to assist in opening and holding the door during dumping.
- The width of the machine should decrease from sixty inches to approximately forty inches. Decreasing the width will improve turning radius and make the machine less susceptible to interference between the auger and the ground.
- The auger and interior of the hopper should be coated with a paint or material which has low friction. This would help the auger to convey and make debris slide out of the hopper more easily.
- The bearing concept should be changed to a "true self aligning" bearing as discussed in section 5.4.4.3.

Chapter 8 Patent Application

8.1 Patentability of Original Concept

As discussed in section 4.2, the new design is similar to that of an upright vacuum cleaner and a two stage snow blower, but still patentable. The main argument for patentability is that a central discharge auger with compliant attachments is used to dislodge embedded debris and convey it to an area in front of, and midway along the auger. As explained before, this should reduce the amount of power required, thereby allowing for a smaller, less costly engine to be used.

With respect to a vacuum cleaner, the new design is substantially different because it uses a rigid core auger to convey debris, whereas a vacuum cleaner uses a non-conveying drum as the core. With regard to a snow blower, the new design is differentiated by the fact that the debris cleaner is specially made for cleaning delicate surfaces without causing damage

8.2 Approach to Patent Application

When in junior high, the author participated in a Junior Achievement workshop which taught that a working prototype of a device was needed before a patent could be filed. With this thought in mind, the author did not plan to have the patent finished until the prototype was complete. Later, during conversations with Professor Slocum, the author would learned that a working prototype was not necessary to file a patent.

The original plan caused delays in speaking to potential sponsors, as the companies would either not sign a confidentiality agreement which adequately protected the inventor's writes, or not discuss an invention which was not patented (or patent pending.)

8.3 Process of Patent Application

The filing of the patent followed the flow chart seen in Figure 8-3.1.

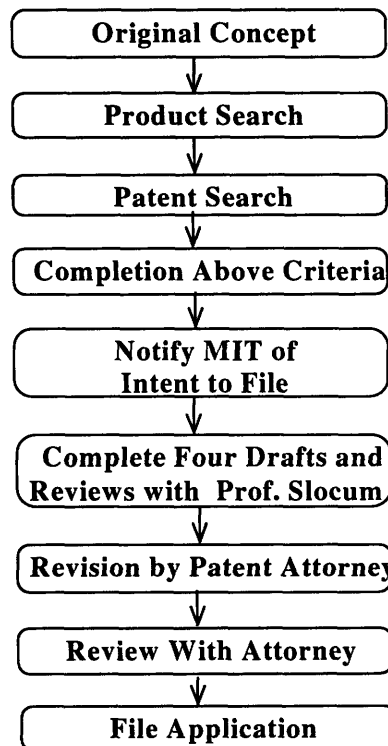

Figure 8-3. 1 Flow Chart of Patent Application Process

8.3.1 Performing a Patent Search

A full patent search can be done in the public libraries of state capitals. One can now perform a limited search through the home page of the United States Patent Office. A patent search involves choosing different categories under which an invention could fall, then searching these topics in the patent database. In this case, categories searched related to snow blowers, vacuum cleaners, augers, brushes, leaf sweepers, street sweepers, debris cleaners, and lawn and garden equipment.

Searching the database on microfilm is a very long and arduous task. It is recommended that the product search be done before the patent search as the prior takes a few hours, whereas the later takes much longer. Following the product search, a limited search should be run using the internet. Only after these two searches have been done, should the full search be started. For the debris cleaner patent, 20 hours were spent finding, searching, and reading microfilm.

While doing the patent search, some augers with wiping or elastometric attachments were found. These attachments consisted of strips of rubber or a similar material attached to the end of the auger flighting. In all cases, the machines could not be used as a lawn cleaners because the attachments would not be effective in dislodging embedded debris without damaging the lawn.

8.3.2 Legal Responsibilities

Alexander Laats, of the MIT Technology Licensing Office, was notified of the inventors' intent to file. This was done as this project was sponsored research in which significant MIT resources and funds were used. As such, MIT had a substantial interest in the patent. Based

upon current patent law (with MIT as an employer) and written agreements (between MIT and the inventors,) the inventors could file the patent, but the rights would belong to MIT.

8.3.3 Standard Form of a Patent

The patent was written using the standard form. The sections and advice for writing them, are listed below:

- **Title**

Descriptive title which conveys what the invention is or does.

- **Background of the invention**

This section tells about prior art. Works of prior art are previous or competing inventions which do the same or similar things. This section should be used to explain the flaws in the other designs, and why the new design is better.

- **Summary of the invention**

Gives a summary of the invention, its features, and what it does.

- **Brief description of the drawings**

Tells what type of view (e.g. side, top, rear) is seen in each figure and explains in a few words the subject of the figure. For example:

"FIG. 1 is a side view of a debris cleaner according to the invention.

FIG. 2 is a front view of the debris cleaner of FIG 1.

FIG. 3 is an exploded view of a collection hopper of the cleaner of FIG. 1."

- **Description of a preferred embodiment**

Very important! Uses the figures to describe the invention and how it works. The description must be complete and very specific. Any time a component of the machine is referenced in this section, the number which denotes that part on the figures must follow the word in the text. For example:

.."the bristles 12 on the brush 13 are used to apply a coat of paint to the wall 14. The brush 13 is held by the handle 15 and the bristles 12 are pressed lightly against the wall 14."

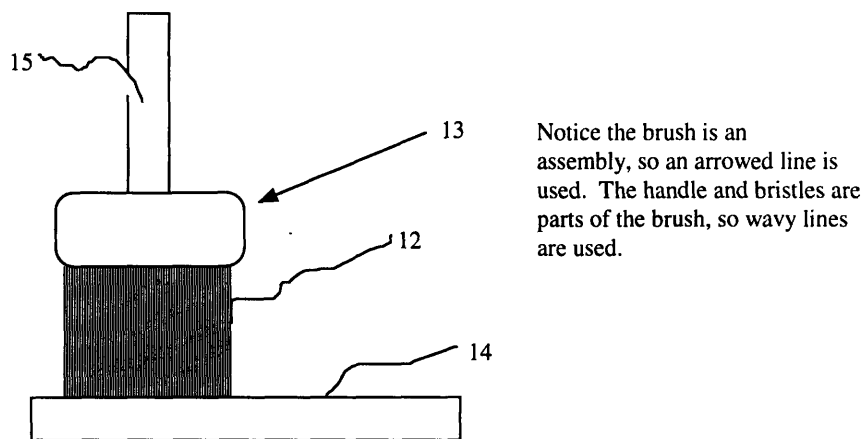

Figure 8-3. 2 Sample Patent Figure

- **Claims**

The claims are one of the most important parts of the patent. They tell what is novel or special about the invention. The inventor should draft a set of claims that explains what is novel. When the attorney(s) reviewing the patent reads them, it will let them know what you believe is important about your invention.

- **Abstract (in a patent application)**

Just like the abstract in a technical paper, the abstract is a brief summary of the invention and its features. Make it short, sweet, and to the point. Note that the abstract comes after the claims in a patent application

- **Drawings**

These are drawings which needed to explain the invention. They should be detailed enough to show all the parts clearly. One should make sure to have enough views which show all of the parts of the invention clearly represented by a number as directed in Figure 8-3.2.

8.3.4 Benefits of Writing a Patent

Self composition of the patent, then review by an attorney has two advantages. First, the cost of paying an attorney to write a patent can be high. One can write their own patent instead of paying an attorney for several days of work. Depending upon the length and complexity of the patent, several thousand dollars can be saved.

The second benefit is that the inventor(s) are the experts. To write the patent, the attorney must become familiar with the invention. This usually involves some time invested by both the attorney and inventor(s). Note here that the inventor's time is free, but the attorney's is not. If the inventor(s) write the patent, it can serve to educate the attorney as he reviews it.

Drafting a set of claims is also recommended. Some entrepreneurs and inventors write their patents, then run into trouble on technicalities. This is especially true when it comes to writing claims. Claims are one of the most important parts of a patent because they "claim" what is new and novel about the invention. Poorly written, claims can result in a patent which offers little protection. In some cases, a set of comprehensive (to the lay man, well written) claims may offer little protection if the wording used is not in compliance with the "legal intricacies" of patent law.

It is best to have a patent attorney with the knowledge of these intricacies, review and amend the patent so that protection is not jeopardized. For an example of a "legal intricacy," take the following phrase, "*The attachments may consist of, but are not limited to compliant rubber fingers, a compliant material impregnated with soft bristles or wires, compliant bristles or wires, or any device or combination....*" In this case, when the words, "may consist of" are used in a patent, it is understood that this includes the string, "but are not limited to." In this example, the error is not significant as it resulted in a redundancy. In other cases, however, an unwitting error in semantics could jeopardize the patent.

The patent was reviewed by patent attorney, Robert J. Tosti, from the firm Testa, Hurwitz, and Thibeault. One review was held with Mr. Tosti to fix minor misunderstandings, then the patent application was submitted.

8.4 Patent

The patent filed with the application is the same as the final draft finished by the author (with minor revisions by the attorney.) The full patent application is presented in Appendix B.

8.5 Recommendations on Patenting of Ideas

The author recommends the following for those trying to patent ideas:

- Complete the patent application as quickly as possible, this offers patent pending protection of the idea and makes discussions with a potential licensor easier.
- If the full patent application cannot be completed before negotiating with a potential licensor, apply for a provisional patent. A provisional patent is one which allows a nearly finished patent to claim the provisional application date as the application date of the formal application.
- Be specific in the section on the background of the invention. Detailed explanation of prior art, including the patent numbers of previous designs, is highly recommended. Any brochures or magazine article referenced should also be included with the patent application. It shows the patent examiner that the author of the patent has been thorough in his search for similar inventions. Also, the patent author has just made the examiners job easier by providing much of the search material.
- Consider buying patent insurance. Many large companies have little objection to pressuring individual inventors or small companies into low royalties. This is often done by infringing on the patent and "daring" the patent holder to spend the money to sue. If the patent holder is not able to, the company will offer royalties which are substantially lower than the inventor should receive. Patent insurance provides some relief if legal fees are incurred in protecting the patent.

- The patent must be applied for within a certain time limit of conception or public disclosures. Patent law is dynamic, so check these dates before disclosing your design.

- Keep a dated notebook in case your idea is accidentally disclosed or someone else has the same idea. Being able to prove you had the idea first can mean the difference in millions of dollars in royalties and nothing.

- Consider international patent protection if your idea may be used abroad.

- A patent pending device may be of more use to an inventor than one which is patented.

Once an invention is patented, the claims may be accessed by the public (potential licensor) and used to invent a similar machine which "gets around" the claims of the original patent. For this reason, one should not send claims to a potential licensor if his or her device is patent pending.

- Have someone who is not an expert on the invention (but familiar with the concepts) read and critically evaluate the description of the preferred embodiment to make sure it is clear.

- Write as much of the patent body and abstract as possible. First, it saves money because the attorney doesn't have to write it. Second, it saves money as it serves as a tool to quickly familiarize the attorney to the project.

- Write a set of claims for the patent. They will let the attorney know what you believe is important about your invention.

- When drawing the patent figures, take note of the way parts of the figures are tied to the reference numbers. Wavy lines should be used to show different components or parts of an assembly. Arrowed lines typically denote whole assemblies or machines.

- Ask questions while reviewing modification of the patent with the attorney. Changes in semantics, organization, and especially the claims, can be valuable information which could be helpful when writing future patents.

Chapter 9 Marketing

9.1 Background

The original goal of the project was to start a company producing the machine. Midway through the project, the author decided to pursue a Ph.D. in machine design. The focus of the project shifted from finding venture capital to finding a company to license the idea.

Also, a second prototype had been built to help demonstrate how different components of the machine could be used in alternate designs. The hopper design of the original prototype was connected to the mower deck of a lawn tractor and a fan was mounted to the hopper just as in the original prototype. Power was delivered from the PTO of the lawn tractor to the fan via a gear box mounted adjacent to the fan.

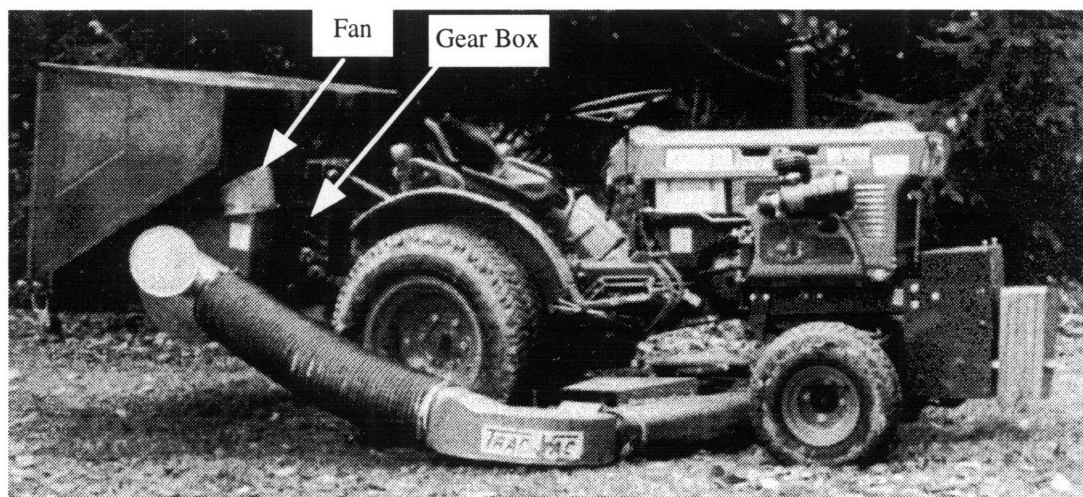

Figure 9-1. 1 Second Prototype of Debris Cleaner

9.2 First Marketing Strategy

The author believed the best way to sell the idea would be to send brochures to the engineering staff at various lawn and garden manufacturers. However, first the author needed a "catchy" name for the product. Thus was born the Leaf Slayer. The logo and name used in the brochures is shown in Figure 9-2.1.



Figure 9-2. 1 Name and Logo Used For Marketing of Debris Cleaner

The second step was to send the brochures to the engineers with a follow-up call. Based on the technical data, patent, and friendships developed through the phone conversations, it was thought the machine would be easy to sell to the engineers. The author would then use the engineers as "champions" to help push the design to the marketing staff.

First contact was made with John Deere in the middle of April, 1996. After several weeks of conversations, the marketing department for John Deere lawn and garden equipment decided that there was not a market for this type of debris cleaner. Their reasoning was that collection was becoming "a thing of the past" as rules on the dumping of material in land fills was becoming more strict.

9.3 Second Marketing Strategy

It appeared that even with the research engineers acting as "champions," the marketing and sales engineers held "the purse strings." The initial brochure was technical in nature and geared toward the engineering staff. It was also too long. Changes were made to the design of the brochure to give it more of a marketing flavor. These changes included shortening of the brochure, more discussion of alternate designs (emphasis on second prototype,) market analysis, and more graphics describing the physics of the problem.

In late August of 1996, the new brochures were sent to Toro, Gravely, and Ingersoll. The author had difficulty in obtaining an address for the engineering department at Trac-Vac™. When Trac-Vac™ was contacted, calls were not returned.

Three companies, Ingersoll, Gravely, and Toro reported more interest. Ingersoll showed the most interest and invited the author to their location for a presentation to the CEO, Director of Engineering, Vice-President of Marketing, and a consultant. The presentation was given before the working prototype was finished. Feedback from the presentation was moderately positive, so a video of the prototypes in action was sent later. The marketing and sales representatives from both Ingersoll and Gravely reviewed the video of the two prototypes in action, however, they decided not to pursue the invention, its components or any variations (at the time). The reasoning behind Ingersoll's decision was that they did not have the resources to properly develop the new line (or components) of the debris cleaner and that they felt their cleaners out performed the Leaf Slayer. For

Gravely, they were unsure if there was a market for this machine. At the time of this publication, the inventors were engaged in preliminary discussions with Toro.

9.4 Discussion of Marketing

The author quickly learned that selling an idea is the hardest part of a product/market thesis. During the product research phase of the project, the author visited different lawn and garden shops and asked them if they would be interested in such a machine (without disclosing proprietary information!.) With the exception of one dealer, all said that there was a need for such a machine. To have the manufacturers of such machines suddenly say there was no need was confusing. This made the author wonder how the companies did their market research. Did they talk to their dealers? Perhaps the author could reverse this and have the dealers talk to the manufacturers.

Although the idea had not found a buyer at time of this publication, the author plans to keep trying. The next approach will be to catch the attention of lawn and garden manufacturers by going through their dealers, in effect, seeding interest in the very group the manufacturers should be using for their market research. By bringing the research to the manufacturers, the author hopes to impress that there is a market for the Leaf Slayer.

9.5 Forms of Media For Selling Ideas (Reference Appendix A For Examples)

9.5.1 Internet

The internet was considered as a vehicle for marketing because all that was needed was to direct interested companies to the correct address where voice and video could be used in combination. The author discussed this idea with Chris Ho, a Ph.D. candidate at MIT. Discussion with Mr. Ho led to the conclusion that a "web page" for the product would not be as effective as first thought. Loading video and sound would take too long to hold the attention of mildly interested parties. Also, Mr. Ho felt that the internet had not proven itself to be an effective means of selling products such as the Leaf Slayer. The final decision was that creating the page would be of little benefit.

9.5.2 Presentations

Presentations are one of the most powerful ways for an inventor to sell a product. Being physically in the same room with interested parties allows the inventor to "show his stuff" and make sure questions about the invention are fully answered. This is something which can be difficult to do via fax or telephone. Why? Because body language is an important part of communication, especially when describing things. For some people, being able to see someone show how a particular part moves with gestures (or models) is much easier to understand, than looking at schematics. This is particularly true for those without technical backgrounds.

Tips for Presentations

- Find out how much time is allotted for the presentation. Construct slides to fill the entire time. Allow about one to two minutes per slide and five to ten minutes for questions.

- Limit the number of words per slide to about fifteen, unless absolutely necessary. People tend not to look at a screen with more than fifteen words unless they are looking for a particular item. If this is the case, make sure the item of interest is distinguished from the rest of the text or spreadsheet.

- Use of correct font and colors are important. Never use anything smaller than a bold 16 font. If possible, use an Arial font or other "easy to read" font. Color helps keep the attention of the audience. Colors such as gray, brown, yellow, light orange, and lavender should be avoided as slide backgrounds because they can "put people to sleep." Dark, rich colors, such as deep blues should be used.

- Practice, practice, practice! If at all possible, practice in the room in which the presentation will be given. This will help with pre-presentation nerves as the surroundings will seem familiar. It also prepares the presenter for things such as cords, which are easy to trip over when nervous. If the cord or projector locations are a problem, the presentation should be choreographed accordingly.

- A few of the practice sessions should be taped. This will help the presenter watch for hand gestures, tone of voice, and nervous habits which are hard to notice when practicing.
- Always tell the audience what is to be covered, cover it, then tell them what was covered.

9.5.3 Videos

Videos are another effective vehicle one can use to sell ideas. A video allows the inventor to show how their invention works. This can be especially helpful when the interested parties are skeptical that the invention will work.

Tips for Making A Video

- Prepare a script before hand. If possible, time the wording of the script so that it matches the different sequences in the video.
- Have the video professionally done. Amateur videos can be effective, but a professional presentation will help.

9.5.4 Product Sheets and Brochures

A product sheet is a double-sided, one page document which explains the product and its features. The purpose of the sheet is to interest customers and potential sponsors by showing the most beneficial features of the product. Start by prioritizing the information to be put into the sheet. The most important features and pictures should be put first, with lesser features on the opposite side of the page. Items of particular interest should be high-lighted, in bold, or with bullets.

A brochure is an extended version of a product sheet, typically a two page, double-sided, document which explains the product in more detail. This type of media is useful when approaching people with interest in the technical side of the invention.

9.5.5 Other Vehicles for Marketing

Other forms of media such as magazines, info-mercials, "starving artists" sales, and home shopping networks can be effective, depending upon the product.

Chapter 10 Project Schedule

Much of the success of a project depends upon the ability of the product manager(s) to organize, plan, and execute effectively. During this project, the author found that many well thought out plans proved less than fruitful because of lack of experience, contingency planning, or taking the wrong approach. This chapter is provided to show why the progress of the project varied from that planned. In each section, knowledge gained and reasons for discrepancies between the project schedule and progression of work are discussed.

10.1 Schedule For Research, Concept Generation, and Modeling Phases

Initially, the project was broken into five phases, laid out to start a business. In early March of 1996, however, the focus of the project shifted from starting a new company to finding someone to license the technology. It was at this point that the sixth phase, marketing, was added.

1. Research
2. Concept Generation
3. Models
4. Prototype
5. Patent
6. Marketing

Progress made during the research, concept generation, and modeling phases is shown in Table 10-1.1.

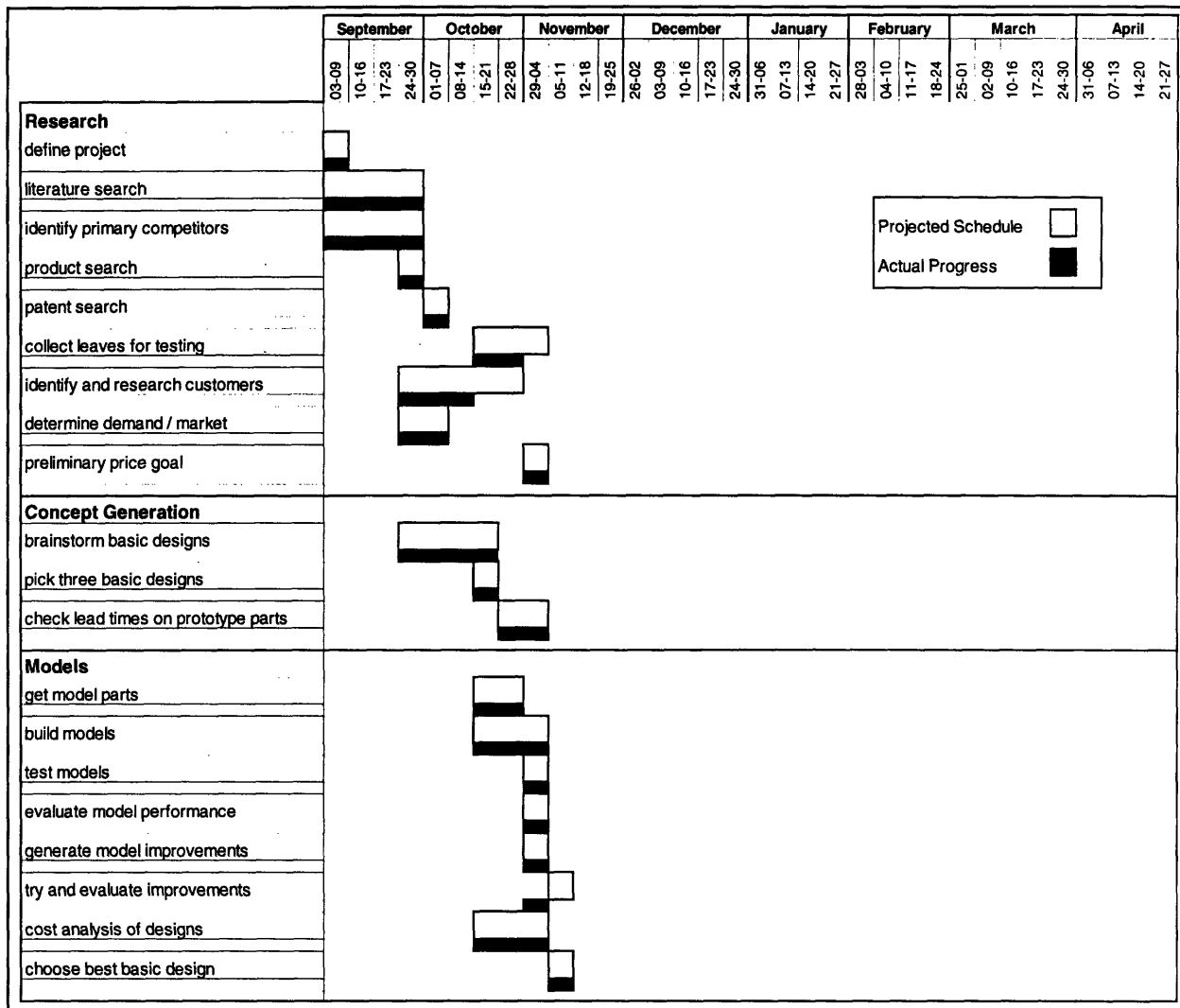

Table 10-1. 1 Project Flow For Research, Conceptualization, and Modeling

After the initial research showed that the project was worthwhile, the schedules for each phase of the project were completed. Table 10-1.1 shows the schedule for the first three phases.

All parts of the research, concept generation, and modeling stages were finished by the scheduled completion date. In the case of "trying and evaluating prototype improvement" (under models,) several different designs were tested, and one worked as needed. There was no need to spend an extra week trying to improve the design.

10.2 Prototype Schedule

In Table 10-2.1, note that behind each schedule block appears a number. Negative numbers show the amount of time the particular phase or component was behind the original

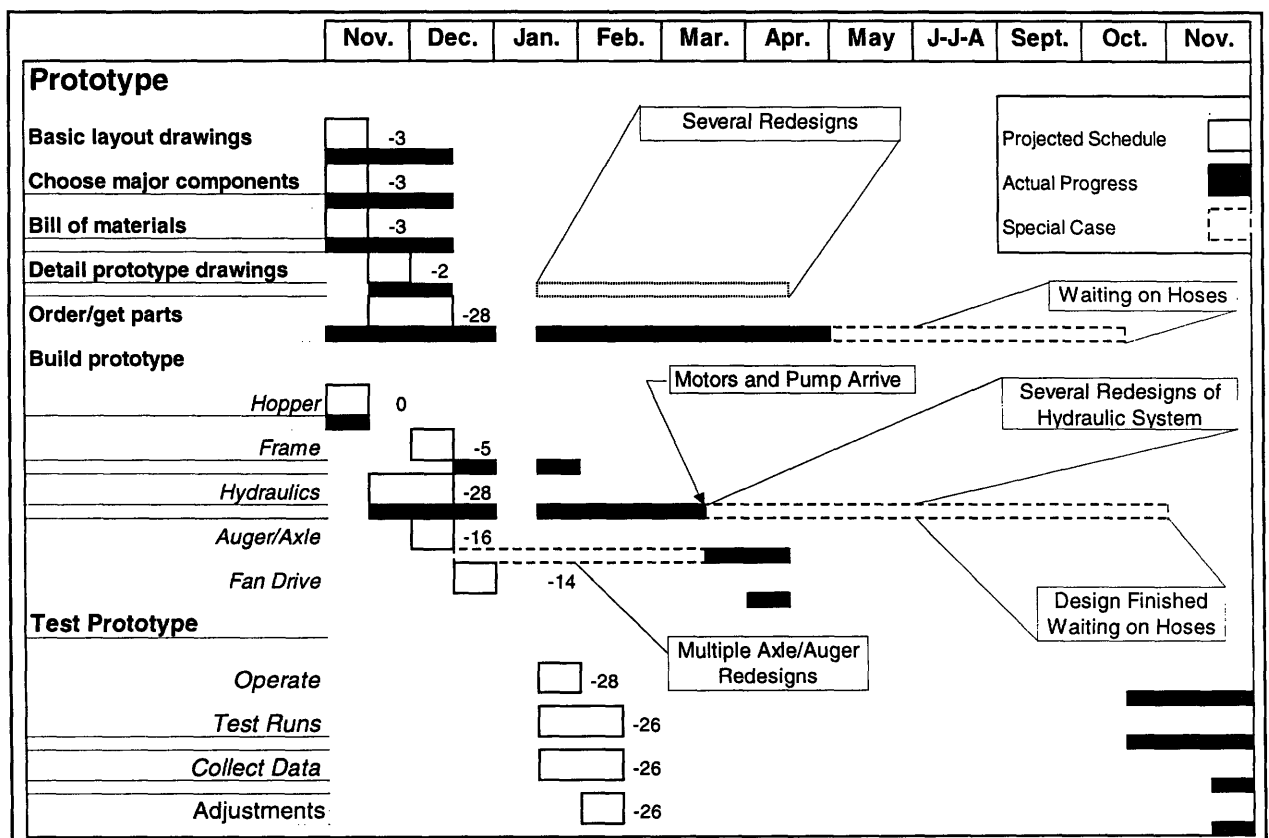

Table 10-2. 1 Prototype Project Schedule

schedule. Note that weeks during June, July, and August were not counted as the author was in another state working at an internship. Also, note that time blocks outlined by dashed borders indicate parts of a phase where minor work was being done, or where there were special problems.

10.2.1 Discrepancies Within Prototyping Phase

A quick glance at Table 10-2.1 shows that most parts of the prototyping phase fell behind schedule. Many of these delays were due to one or more of the six reasons below.

1. problems with the 3-D Modeling system
2. problems with the design and procurement of the hydraulic system
3. inexperience in judging the time needed to finish components of the prototype
4. design mistakes and redesigns
5. not allowing enough cushion in the schedule to allow for mistakes
6. supplier problems

Following, special attention is given to some of the delays in which the author either learned something or wishes to explain the delay.

10.2.1.1 Delays in Detail Drawings, Choosing Components, and Bill of Materials

The two choices of programs to use in solid modeling of the prototype were Pro Engineer™ and Auto Cad™. Tables 10-2.2 and 10-2.3 shows the pros and cons of each program.

Table 10-2. 2 Pros and Cons of Pro Engineer™	
<u>Pros</u>	<u>Cons</u>
1. becoming the industry standard, would be a benefit to learn it	some trouble foreseen with accessibility of work stations
2. students in the lab with knowledge of the program could be used as resources for help	

Table 10-2. 3 Pros and Cons of Auto Cad™	
<u>Pros</u>	<u>Cons</u>
1. more accessible	no resource people if problems arose
2. already familiar with Auto Cad™	limited three dimensional capabilities

Auto Cad™ was used for three dimensional modeling of the prototype as the author was already familiar with the program and had better access to it. In the beginning, it seemed that using Auto Cad™ would be less "painful," however several problems arose. Auto Cad™ was fine for modeling simple items, but ran slowly when modeling complex parts. As there were a number of complex parts (such as the auger and fan assembly,) modeling took much longer than

anticipated. Also, there were a number of changes in many of the complex parts, so additional time was allotted for these tasks.

The modeling was done on a computer equipped with a 66 megahertz Pentium™ and eight megabytes of random access memory (RAM.) For small Auto Cad™ drawings, this was sufficient, however, when the size of the prototype model passed three megabytes, system performance began to suffer. Simple operations such as rotating objects, opening drawings, and saving work would often take several minutes.

Attempting to move the drawing to a machine better suited to the task was impossible, as the file was too large to transfer via disk (at the time.) Later an additional eight megabytes of RAM were added to the machine. This decreased drawing time substantially, but by this time, the prototype modeling had been nearly finished, save a few minor design changes.

In retrospect, making the decision to go with the Auto Cad™ platform was all right, but the author learned an important lesson: **It was much more important to work on hardware and designs in the beginning, than to spend time struggling with drafting program!** Delays that resulted from these modeling problems translated into delays in choosing components and finishing the bill of materials*

10.2.1.2 Delays in Reference to the Hydraulic System

The first drive train concepts called for sprockets, clutches, and gear boxes. In early November, the inventors decided to use hydraulic motors to power the auger and fan. Once the power requirements of the hydraulic motors had been estimated, the iterative process of choosing

components began. A discussion of why this process had to be repeated several times is provided so that the reader may realize how time was lost in this area.

Design 1 (early November) A spreadsheet was made to do the calculations, greatly speeding up the iteration process. When the first design was selected, a local Sauer-Sundstrand dealer was contacted. At first they quoted delivery in a few weeks, then later informed the author that the parts would not be available for another two months. Hoping to obtain components faster than this, the author turned to another source.

Design 2 (mid-November) Eaton agreed to donate equipment and provide technical help. The author did not have an Eaton catalog and was anxious to finish the design, so the system parameters were given to the Eaton technical staff. Later it was found that the assisting person had used a maximum operating pressure (not recommended for normal use) in the calculations in place of a running pressure. When the author received a catalog, he checked the motor parameters to make sure the design would work. This is when the mistake was discovered.

Design 3 (mid-November) A combination of Eaton pumps and motors could not be found which met the design requirements. An adequate system was constructed using a Sauer-Sundstrand motor for the fan, an Eaton gear motor for the auger, and an Eaton gear pump. Another area dealer of Sauer-Sundstrand, Hydro Air, was contacted as the author was not satisfied with the first Sauer-Sundstrand dealer.

* Although components were chosen in late 1995, design changes made it necessary to purchase some components in 1996.

Design 4 (late November) Through conversations with Hydro Air, it was pointed out that by changing the Sauer-Sundstrand motor displacement, the design could be made more efficient. After several iterations via spreadsheet, a different Eaton motor and pump were selected to match the new Sauer-Sundstrand motor. The dealer reported that the motor would be available by the middle of February. This was acceptable, as the author was told that the donated components would take at least that long to arrive.

The two motors and gear pump, were not received until March of 1996. By this time, there were problems in redesigning the axle, auger, and fan drive. Work on the hydraulic system was done when possible during the continuing weeks. Later, three redesigns were done, with each iteration taking about three working days. When the order was finally placed, it took the better part of four months to obtain the hoses, fittings, manifolds, and gauges.

The reason for the delay was on the supplier side. Originally, the hoses were to be supplied around April or May of 1996. The supplier missed this deadline. Later, the author made arrangements to travel from Ohio to Massachusetts (during an internship) to pick up the hoses and assemble the system. The supplier missed this deadline also. In October of 1996, most of the hoses were delivered, however, a good deal of the fittings were incorrect. After four different trips to get the correct fittings, the author turned toward another source.

The author was far too patient! Originally a deal had been struck with the hose and fitting supplier. If the supplier helped in the design of the hydraulic system, the author explicitly agreed to let that supplier provide all of the components. Early on, the author had made it a point to develop a relationship with many of the suppliers. In this case, the vendor took advantage of that

relationship (as did other vendors.) Believing in the supplier's sincerity, the author naively extended more time when he shouldn't have.

10.2.1.3 Delays in Reference to the Auger/Axle System

As explained in section 5.4, the first design used a straight axle made to fit the auger of a snow blower. The bearings provided with the auger had an inner diameter of 0.75 inches. Preliminary calculations done with estimated loads, showed that the stresses produced in the axle could be handled by this design, if the axle were made of hardened 4140 steel. Later, it was realized that the weights of the engine, frame, hydraulic tank, and other structural components had been underestimated. The extra weight presented two problems. First, the fatigue factor of safety was substantially less than one. Second, the weight supported by the wheels was now over the rating of the wheel bearings. The only way to fix the problem was to redesign.

Then problems appeared on the supplier side with the auger. Most of the manufacturers which were asked to supply the auger quoted a five to six week delivery. One manufacturer, was found which could deliver in four weeks. Later the author was informed that the manufacturer could not obtain the pipe to make the auger in time to meet the four week delivery period. Delivery was now quoted at six weeks. Changing the pipe size was not an option as many parameters, such as the bearing diameters and axle diameter, depended upon the dimensions of the auger pipe. It was very fortunate that the author had found a combination of parts which would fit the auger pipe in the first place. Since no combination of readily available components (with lead times less than five weeks) could be found, the six week wait was incurred.

After the auger was delivered, holes drilled and tapped in the ends of the auger (for attaching the bearing inserts) took longer than expected. Then the sprocket purchased to slide on the end of the auger (with 0.020 inches clearance in the diameter) was found to have a taper. The sprocket bore had been hardened, so turning the bore required extra time. Also, the inner and outer diameters of the pipe were out of the tolerance specified by industry standards. The dimensions of the diameters had to be opened with a hand held grinder.

10.2.1.4 Delays in Reference to the Fan Drive

The fan housing was designed to be attached to the hopper as shown in Figure 5-3.6. Note the limited space in which to position the hydraulic motor. This design had been seen on another cleaning machine with a hydraulically driven fan. Later, Professor Slocum noted that if a piece of debris were to become stuck in the rotating fan, large forces would be transferred to the shaft and bearings of the hydraulic motor. This presented a problem as the frame and hopper had not been designed to support a structure on which to mount a separate shaft support. Several concepts were generated while trying to find a solution to the problem.

A decision on the final design was made in early April. Raw materials for the new drive were obtained within days, however, machining of the components took longer than estimated. Chatter was a problem when machining these parts. As a result, the material removal rate per pass in these cases was limited.

Some pieces which the author had planned on milling or lathing had to be ground to achieve the desired flatness, surface finish, or tolerances. This required the use of a cylindrical or a vertical face grinder. The cylindrical grinder had not been used for some time and took

approximately six hours to set up. Most pieces done on the vertical face grinder had large contact areas and so generated a lot a heat. Material removal rate was limited to prevent warping from heat. Pieces machined on this grinder typically took thirty to forty minutes to process.

As explained in Chapter 6, machining of the axles and fan shaft was more complicated than anticipated. The author found that there was a small "window" (usually between 0.0250" and 0.0200") in which the set removal rate was close to the actual number dialed in on the lathe. Considerable time was spent adjusting machining parameters to get the desired dimensions (finish cut had to be taken at a depth of 0.020" to 0.025", not 0.003" as is typical.)

10.2.1.5 Delays in Reference to Prototype Testing

Testing was done on a test field in Bow, New Hampshire. Location of the test field made testing during the week difficult as the author was attending classes at the time. As such, most of the testing was done on weekends. During the first attempt to test, the speed control on the auger malfunctioned. On the next weekend, the valve was replaced, and testing started again. After approximately two minutes of testing, the seal on the fan motor went bad. The inventors later found that a relief line from the fan's case drain had been plugged. A new seal kit was ordered (which took approximately one week to arrive) The motor was rebuilt the next weekend, then testing of the prototype was done on the following two weekends.

10.3 Patent Schedule

As explained in section 8.2, the author believed that a working prototype was needed before a patent could be written. As such, a finished draft of the patent was not scheduled until after the completion of the prototype. Note, the prototype was scheduled to be finished in January.

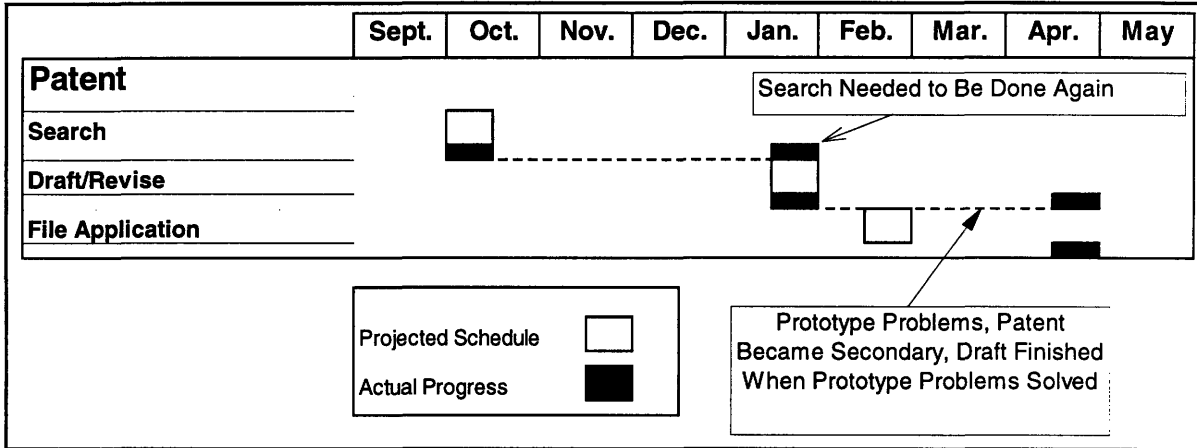

Table 10-3. 1 Patent Schedule

Most of the patent had been finished on schedule, however, during the initial patent search, the author did not copy down all of the prior art which would need to be referenced in the patent write-up. The only solution to the problem was to do the patent search over again. When the author realized he would need this information, problems with the prototype had surfaced. Finishing the prototype had become top priority, so the patent write-up was put off until the construction of the prototype was under control. Once time was available, the patent search was done again, and the patent finished.

10.4 Marketing Schedule

The original goal of the project was to start a company producing the machine. Midway through the project, the author decided instead to pursue a Ph.D. in machine design. The focus of the project shifted from finding venture capital, to finding people to license the idea.

First contact was made with John Deere in the middle of April, 1996. The engineers passed the information onto those in charge of marketing and sales. Then contact ceased. Calls to the engineers led to a common cause for the cessation of discussion. Even with the research engineers as champions, the marketing and sales engineers held "the purse strings." New brochures with more of a "marketing flavor" were sent out in late August of 1996. Three

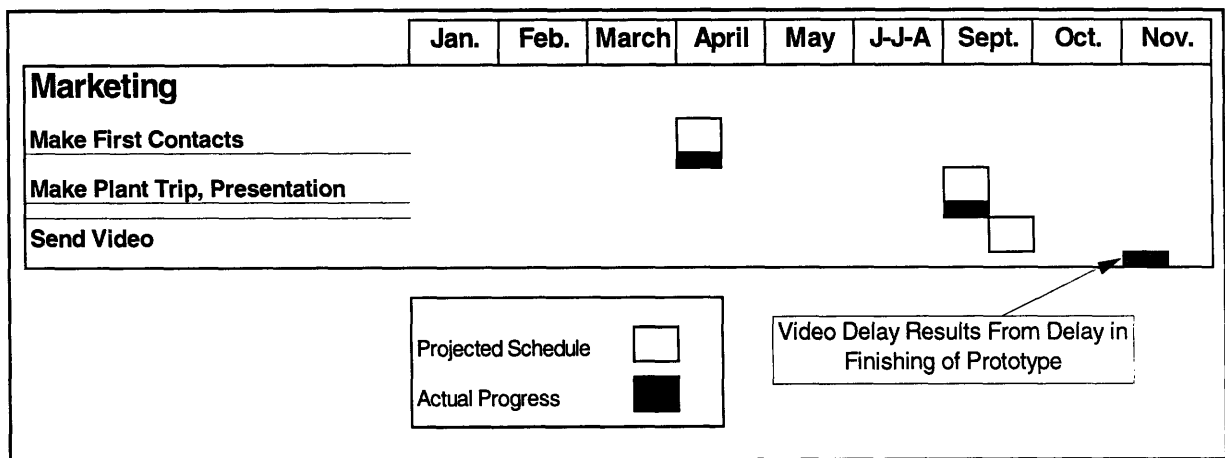

Figure 10-4. 1 Marketing Schedule

companies, Ingersoll, Gravely, and Toro reported more interest. Ingersoll showed the most interest, and invited the author to their location to present his ideas. As was the case with John Deere, marketing and sales representatives from both Ingersoll and Gravely eventually decided

not to pursue the invention, its components, or any variations of it. At the time of this publication, the inventors had entered into preliminary discussions with Toro.

10.5 What Was Learned

Getting Parts, Machining Parts

Most of the author's previous experiences in design came during internships at John Deere and the Timken Company. During these internships, most of the building/procurement of components was handled by the staff in the machine shop or purchasing. When beginning this project, the author did not realize how complex and troublesome getting and machining parts would be. In all, there were approximately 278 pieces to the machine (excluding fasteners.) Of these 278 pieces, 171 needed machining of some kind, and usually things did not go as planned. In addition, approximately fifteen of the machine parts were ordered, then either were lost on the manufacturers end (e.g. vacuum nozzle) or in the MIT shipping room (e.g. drive sprockets and couplers.) This affected the project because tracking down and looking for the parts took the better portion of a work week.

Dealing With Suppliers

In the beginning of a project, the designer should amass as many catalogs as possible. Having the necessary catalogs will prevent hours of time on the phone looking for parts. Also, as seen in section 10.2.1.2, suppliers can make mistakes in recommending parts. Having a catalog and a thorough understanding of the physics of the components in question (usually explained in

the front or rear of the catalog) can save time, especially if the supplier is prone to making mistakes.

When possible, the author turned from the Thomas Registers and used the Yellow Pages. Buying locally has the benefit that one can talk to the supplier in person and explain the concepts more clearly. When done this way, there is less chance of miscommunication than say, when sharing information by fax or telephone. This also saves time as the amount of "phone tag" is minimized.

Visiting the supplier is also recommended because it puts a "name to a face," and helps to develop a relationship. People are more reluctant to cause a delay if they know someone is a friend or will come looking for things (as opposed to calling) if a delivery date is missed. In some instances, this backfired. Some vendors were of the notion that since they were a "friend," they could put things off, and the author would understand. This was the case in obtaining hydraulic components, safety guards for the fan drive, and the hopper of the second prototype. From these experiences, the author learned to be friendly, but also to make it clear when parts were wanted and that going to other vendors was not out of the question.

Planning Too Carefully

In a sense, the author planned too carefully. Many tasks in the project were rigidly interconnected. The author failed to realize this and when parts or phases of the project fell behind, these delays would "cascade" to the following phases. This caused the most problem in daily planning. The author would often schedule things in the afternoon which depended upon achieving things in the morning. If problems arose in completing the morning tasks, the

afternoon tasks could not be done. Often the author was able to substitute or move plans, but having a back up plan in the first place would have helped.

Contingency Planning

Backup plans are a project manager's best friends. As explained in the previous paragraph, delays can cascade through a project. A one day delay here, a two day delay there, can accumulate and add weeks to a project's life. With a back up plan, many delays can be avoided, or their effects minimized.

Time of Month

The author noticed that requests for materials or assistance made near the end of the month were usually put off by the supplier until the beginning of the next month. This was due to the fact that manufactures/suppliers usually have a "big crunch" near the end of the month. In other words, they sometimes fall behind on their orders and have to work to catch up. To the purchaser who cannot go elsewhere, or has a piece in the works, this can cause delays of up to seven working days (example: original hopper for prototype.)

Other Recommendations and Tricks

At night, sit down and list the phone calls and e-mails which need to be sent the following day. Make these phone calls first thing in the morning to get the required information. This way, interdependence on others later in the day is minimized.

Business hours of suppliers often vary by one to two hours. This can be a problem when one has to bounce between suppliers to find matching components. Say vendor A closes at 4:00,

and vendor B closes at 5:00. The time is 4:10 and two critical components (one each from the vendors) are needed desperately. Many times it is possible to call a different time zone for another branch of vendor A, which we'll call vendor A'. Then one can bounce back and forth between vendors A' and B. If lucky, vendor A' will have access to a national database for his company and can tell if vendor A, has the item in stock.

Chapter 11 General Discussion

11.1 Project Goals and Objectives

This section discusses which goals were met, which were not, and why.

Goals:

Design, build, and test a debris cleaner which:

1. will not plug up when cleaning areas with thick debris cover
2. will not plug up when removing wet debris
3. will use less power than conventional vacuums/sweepers
4. will cost less than similar products on the market
5. will reduce the volume of debris by shredding it as it passes through a fan
6. won't damage delicate surfaces
7. can be pulled behind any vehicle (with a proper hitch)
8. cleans better than similar products

Goals 1,2,3,6,7, and 8 were accomplished to the author's satisfaction. Goal 4 was "somewhat" accomplished. The author sat down with Ingersoll's Vice-President of marketing and Director of Engineering, to estimate the cost of the debris cleaner. Between the three individuals, it was figured that the cleaner could be sold to the consumer for roughly \$6500, which is less than the Toro's Rak-O-Vac and similar to the Gravely Pro-Vac. It was hoped that Ingersoll or some other company would become an industrial sponsor and a detailed cost analysis performed using that company as a model. This did not happen as an industrial sponsor had not be found.

Goal 5, shredding of the leaves, was not achieved as the fan used in the prototype did not shred as first thought. The failure of the blades to do this and a possible solution were discussed in chapter 7.

Project Objectives:

1. design, test, and make a product
2. patent the new design
3. gain intuitive feel for design
4. produce the debris cleaner with help of industrial sponsor
5. provide exposure to the following areas:
 - experimental engineering
 - manufacturing/process engineering
 - entrepreneurial skills
 - patent writing
 - project management

Objectives 1,2,3, and 5 were accomplished to the author's satisfaction. Goal 4, finding an industrial sponsor was not. As discussed in chapter 9, the author had difficulty finding a company which was willing to license the debris cleaner. The companies said that there was no market for the debris cleaner or that they did not have the man power to devote to the development of a new product. With respect to lack of resources, the author can understand (some companies had only two engineers.) However, the reasoning that there was not a market for the device was confusing. The author's own research with lawn and garden dealers showed

the opposite. As explained in chapter 9, the author expects to sell the idea of the device to the manufacturers through interested dealers.

11.2 Experience Gained

Had it not been for this opportunity provided by Professor Slocum, I would not:

1. know how to machine
2. know how to write a patent
3. know anything about design
4. know anything about marketing a design
5. have gained an intuition on the strengths of material or tolerances needed for design

In addition, the most important thing I learned was how my style of project management needed to be changed. Before working on this machine, I had led many successful projects while in school and working internships. Most of the time, I finished the projects before schedule, never behind. Working on this project was an eye opener.

In previous projects, I had support staff and the name of a big company, both of which I could use to get things done. As the project grew in complexity, I realized how much I had depended upon these things in the past. This hit home when I started purchasing and making parts for the prototype. Having to deal with vendors and make things fit (for all 278 components) was quite a task. These were all things I did not worry about in the past. Through most of the project, I was not organized enough to properly handle this.

In a project as complex as this, prioritization, organization, and contingency planning would be the keys to keeping on schedule. I admit to not recognizing this until three-quarters of the way through the project. For the first three-quarters I worked harder instead of smarter. Having never been so far behind, I became frustrated and tried to push things through when I should have spent a day or two thinking.

Working hard was no longer was enough. The author was at a strategic inflection point, a place where the "rules" had changed. What had worked in the past, now would not. All entities go through strategic inflection points. For a business, recognizing these points can mean the difference between huge success or going out of business. This concept relates to myself in that I had equated success with hard work. Instead of using prioritization and contingency planning, I tried to tackle problems whenever they came, essentially fire fighting. Had I stopped, thought, and planned better, I would not have fallen so far behind.

11.3 Additions to Résumé and Portfolio

In a product/market thesis, one learns many skills which can be added to a résumé and portfolio. Most people know a résumé as a powerful thing, however a portfolio can be even more so, as the individual has the opportunity to show his skill and knowledge more fully.

Resume Additions

Additions to the pre-project résumé, shown in chapter 2, are listed below.

October 1995 to Present MIT:

- Designed and built a debris cleaner which uses a novel system to efficiently clean debris without damaging lawn surfaces.

Patents

- Debris Cleaner With Compound Auger (pending)

Machining Experience

- Finish Grinding
- Vertical and Horizontal Milling
- Lathe Work

Experience in composing:

- Product Sheets
- Brochures
- Sales Presentations

Portfolio Addition:

October 1995 to Present, M.I.T. :

Objective/Problem:

Design and test a debris cleaner capable of cleaning debris under varying conditions while using significantly less power than conventional cleaners.

Solution^{*} : (reference figures on following pages)

Design uses a patent pending compound auger. Compliant attachments at the edge of the rigid auger flighting comb embedded debris from a surface and deliver it to the auger flighting without damaging the cleaned surface. The flighting on the auger is wound such that the debris is transported to a central collection point. Collecting the debris to a central location allows for the use of a smaller inlet nozzle, which requires less power to maintain a suitable capture velocity.

The debris is vacuumed into the nozzle which is positioned just above the collection point. From there the debris passes through the fan where it is shred, then exhausted to the on board collection device (hopper.) The low cost hopper is made from folded pieces of sheet metal which when assembled, form an extremely rigid structure. The auger and a supporting axle are assembled with their axis substantially collinear. This keeps the auger at a near constant distance from the ground, making it less likely to dig into the ground on uneven terrain. In addition, the design utilizes variable speed hydraulic motors to drive the auger and vacuum fan.

Experience acquired in:

- Conceptual design
- Entrepreneurship
- Patent writing
- Project management
- Machining
- Manufacturing
- Hydraulic system design

^{*} Project done under the direction of Prof. Alex Slocum, M.I.T. Precision Engineering Group

Design:

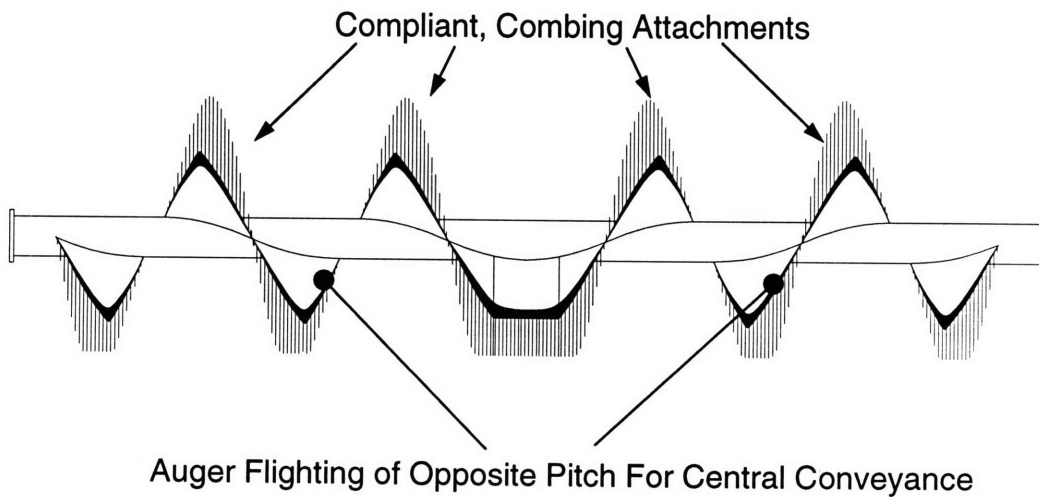
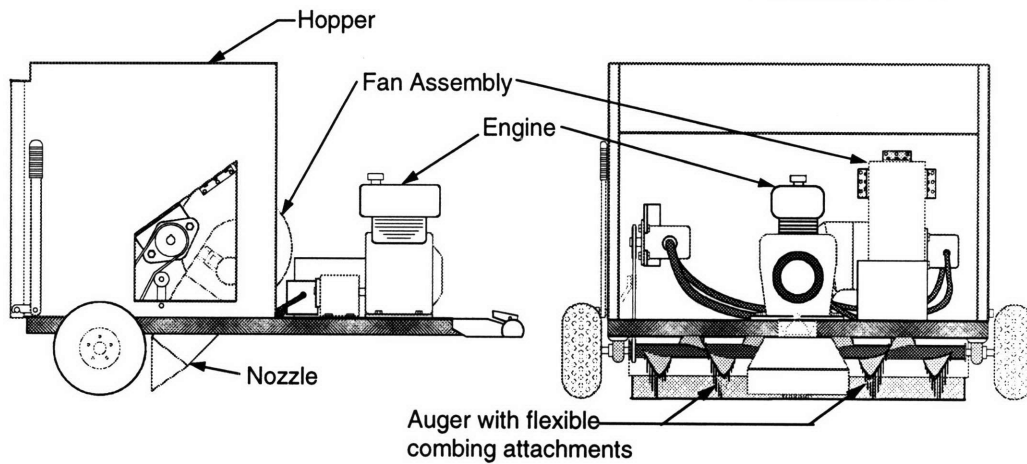
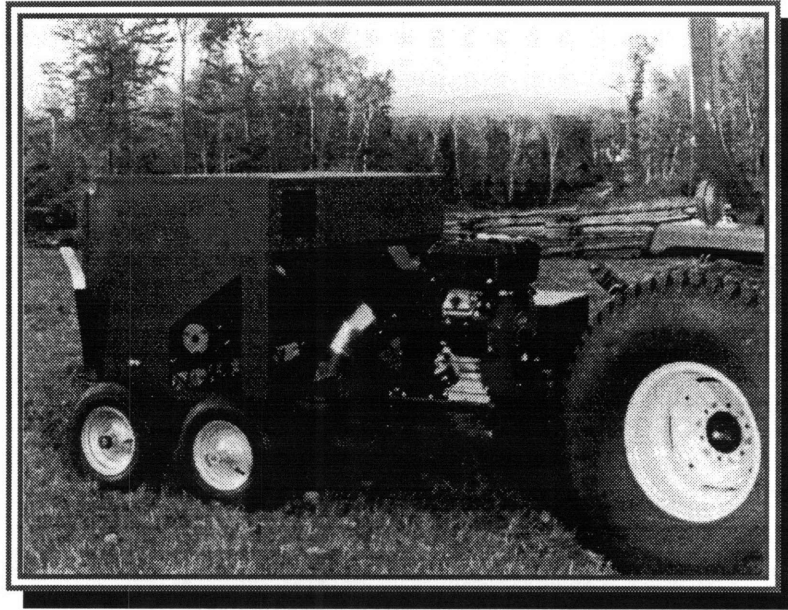

Hopper Assembled As Shown Below

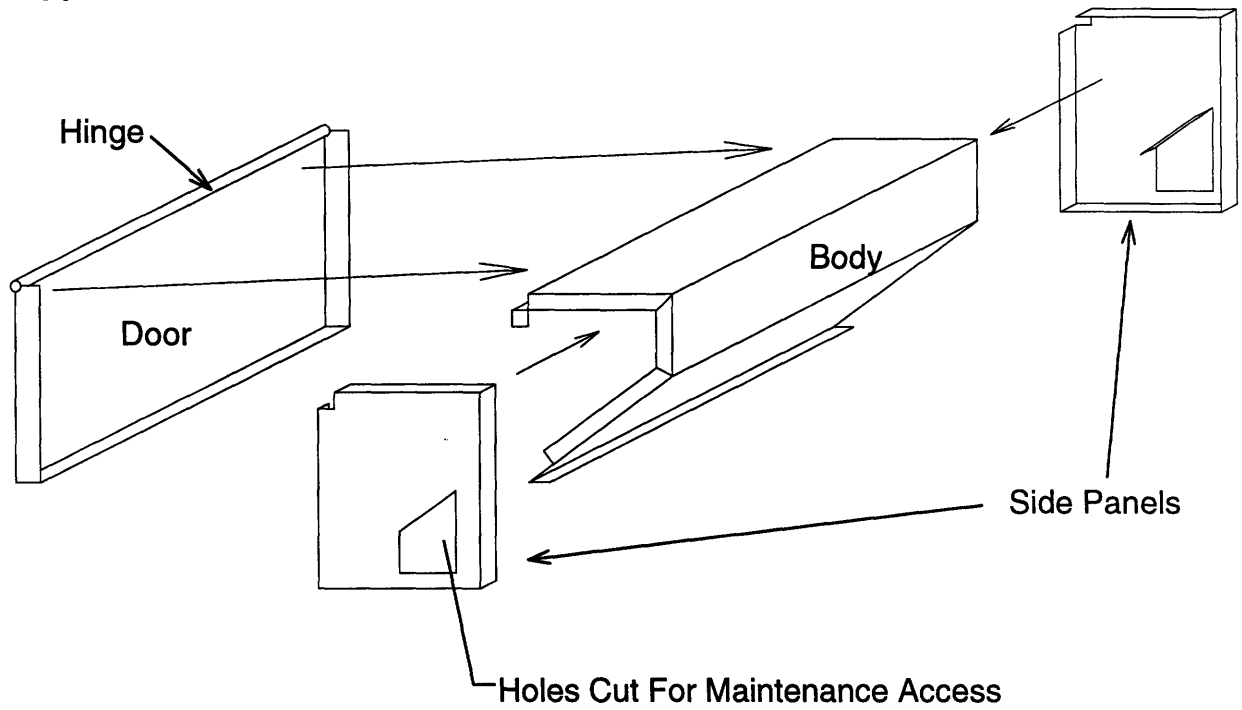

Blow Up of Hopper Joint Overlap

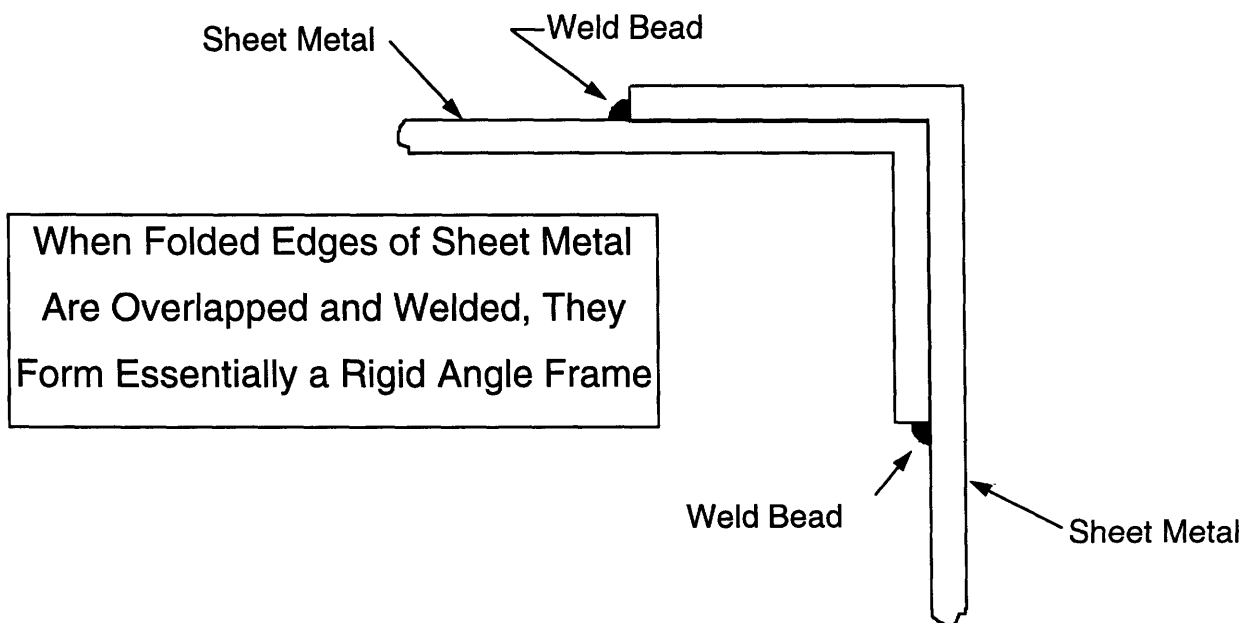

11.4 A Look at the Product/Market Thesis

11.4.1 Recommendations for doing a product/market thesis

For those wishing to do a product/market thesis, I make the following suggestions:

Take a comprehensive seminar in project and time management. Ideally the scope of the class would cover prioritization and contingency planning.

Finish your patent as soon as possible so that you may go talk to people about sponsoring your idea. A working prototype is not necessary, but will help. What is important, is to get your idea "patent pending" so it is protected.

Always have at least one back up plan, two if possible. Efficient use of time in a project will depend upon the project managers ability to side step problems and have some other portion of the project lined up.

If you are the type of engineer (and many are) who latches onto an idea and won't let go; get over it. I used to have this problem before I learned the weighted grade system (used to evaluate different designs.) "Falling in love" with a particular design prevents "cross pollination" with other designs. Although other designs may not be as "sexy" as your first choice, but deep down inside, one of the others may be the better choice.

People may instantly peg you as the "kid with a pet project." This can cause delays in getting equipment or assistance even though you are a paying customer. If you feel this is happening, ditch the supplier with the problem and find another.

When looking for a firm to supply you with critical pieces, visit and evaluate different vendors to find one which you trust to do the job right and on time. A half day spent checking

out different vendors could save a lot of problems in the future. Also, develop a professional relationship with the suppliers of critical assemblies. As discussed in chapter 10, this can help reduce delays.

At the start of a design (i.e. in the concept generation and modeling phases,) worry about quantity of work as opposed to quality. The natural flow of a project is to start out broad and narrow down to a solution. Optimization of designs or prints can be done near the end of the project if needed. For example, do not spend hours cranking out perfect CAD drawings. In two weeks time they will probably change, and the hours you spent optimizing will become wasted time.

Move, move, move! Never stagnate, it can kill your schedule. If you get stuck on a design, ask for help or give it a rest, and go with your back up plan. Oftentimes the author would spend hours in front of a CAD tube trying to fix a problem or optimize a particular thing. Most people have done this and don't realize how silly a waste of time this is until they see another person doing it.

Do not be afraid to say, "I do not know...." A display of ignorance is not a submission to inferiority. It conveys the fact that you need help. "Feigning knowledge" of something can only lead you to hours of trying to figure things out for yourself, or looking like an idiot in front of your peers.

11.4.2 Benefits

In retrospect, the project was most worth my while. I learned many things about machining, project management, and organization. Many engineers never get the opportunity to learn to write patents, brochures, and build a patentable machine. As I compare myself to what I was before this project, I can only wonder, "Would I have ever learned these things on my own?," probably not. Then I ask myself, "How many young engineers know how to do the things I've learned?," and I am afraid, not many.

I look back at many of the designs and decisions I made, and they all seem very simple now. This is more than "20-20 hind sight." Before this project, I knew how to calculate stress and strain and other quantities, but did not have extensive design experience. I was much like the freshman students in the sections of an Engineering Design Workshop which I helped teach. In the workshop, students follow the same process as outlined in this thesis to develop a product. It was somewhat relieving (but not gratifying!) to see these students make the same mistakes I made. Having assisted these students in planning and decision-making has impressed upon myself how much I had learned.

Bibliography

1. Alden, J. A., Kane, J. M., Design of Industrial Exhaust Systems, Vol. 4, Industrial Press, New York, 1975.
2. Alden, J. A., Kane, J. M., Design of Industrial Ventilation Systems, Vol. 5, Industrial Press, New York, 1977.
3. Birk, J. R.; Deeley, D. T.; Harris, J. L.; Panesar, K. S.; Sinclare, R. J.; Syska, R.E.; Willoughby, W. W., Solid and Liquid Conveying, Process Equipment Series, Vol. 4, Techtomic, Westport, CT, 1982.
4. Brick, M. R., Pense, A. W., Gordon, R. B., Structure and Properties of Engineering Materials, Vol. 4, McGraw-Hill, New York, 1977.
5. Jorgensen, Robert, Fan Engineering, Vol. 8, Buffalo Forge Company, Buffalo, New York, 1983.
6. Meriam, H. L., Kraige, L. G., Dynamics, Engineering Mechanics, Vol. 2., Wiley & Sons, New York, 1986.
7. Munson, B. R.; Young, D. F.; Okiishi, T. H., Fundamentals of Fluid Mechanics, John Wiley & Sons, New York, 1990.
8. Oberg, E.; Jones, F. D.; Horton, H. L.; Ryffel, H. H.; Green, R. E., Machinery's Handbook Vol. 24, Industrial Press, New York, 1992.
9. Peterson, R. E., Stress Concentration Design Factors, John Wiley & Sons, New York, 1953.
10. Peterson, R. E., Stress Concentration Factors, John Wiley & Sons, New York, 1974.
11. Shigley, J. E., Mischke, C. R., Mechanical Engineering Design, McGraw-Hill, New York, 1989.
12. Slocum, Alexander H., Precision Machine Design, Prentice Hall, Englewood Cliffs, NJ, 1992.

Appendix A

Marketing

- first brochure
- second brochure
- example confidentiality agreement
- script of video
- example presentation

First Brochure

The Leaf Slayer



Inventors: Prof. Alex Slocum & Martin Culpepper
slocum@mit.edu mculpepp@mit.edu
(617) 253 - 2407



Sponsors:

- National Consortium for Graduate Degrees for Minorities in Engineering
- Defense Logistics Agency (DLA)



Donating Contributors:

- Eaton Corporation
- Briggs and Stratton Corporation



Developed at:

Massachusetts Institute of Technology



Precision Engineering Research Group

<http://pergatory.mit.edu>

The Leaf Slayer^(patent pending)

Property owners spend significant amounts of money removing debris from yards, parking lots, runways, golf courses, and other large properties. In doing so, it is highly desirable to use a machine which consumes a minimum of power and is effective in removing debris which are difficult to separate from the surface being cleaned. It is also desired to minimize the amount of downtime due to clogging of ductwork and repeated emptying of the collection device. Prior machines have attempted to solve these problems, however these machines do not perform as expected. Most are inefficient or cumbersome to operate.

A new debris cleaner, the Leaf Slayer, is being developed by Prof. Alexander Slocum and Martin Culpepper at the Massachusetts Institute of Technology. Due to a clever innovation, the Leaf Slayer is able to clean debris more efficiently and more effectively than available machinery.

How the Leaf Slayer works!

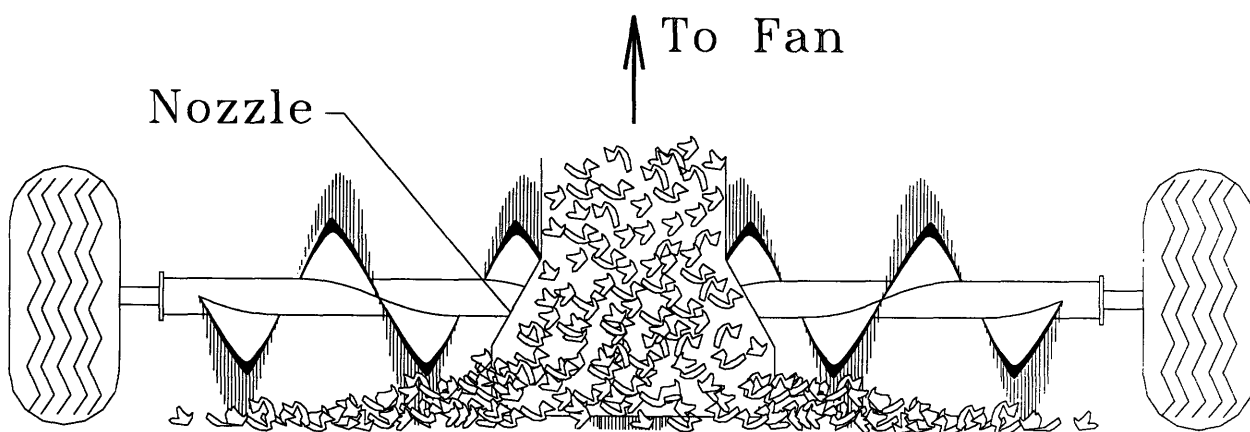
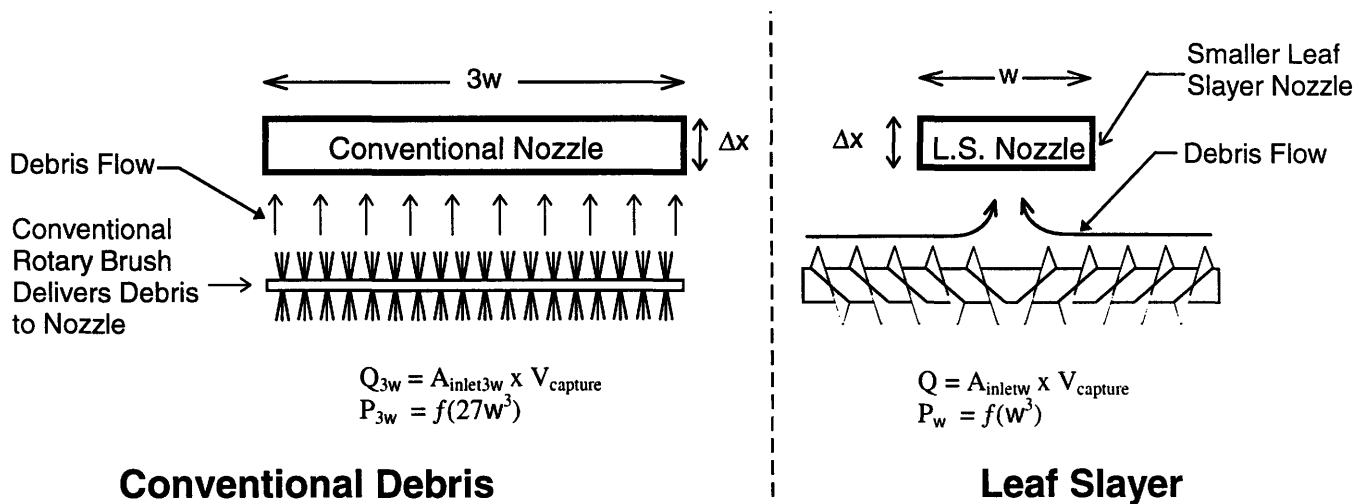

Figure 1 Design of Compound Auger

What makes the Leaf Slayer better than the rest, is the way in which it dislodges and collects debris. Instead of using a rotary brush as sweepers do, the Leaf Slayer uses a compound central discharge auger. This compound auger consists of a rigid inner auger with combing attachments fastened along the edge of its flighting (see Figure 1). Unlike the stiff rotary brushes on lawn sweepers, the combing attachments on the Leaf Slayer are designed such that they offer sufficient resistance to the surface to dislodge embedded debris (such as leaves in heavy grass cover) without damaging the surface. The compliant attachments then deliver the debris to the inner core auger for bulk conveyance to a central area as shown in Figure



1. The debris is then sucked through a nozzle, conveyed through the fan where it is shredded, then dumped to the collection hopper.

If the debris were not collected as above, the nozzle on the machine would have to stretch across the width of the machine in order to suck up the scattered debris. By gathering the material to a central location, the Leaf Slayer is able to use an inlet nozzle approximately one third the size of conventional equipment. The benefit of this is that the Leaf Slayer can maintain the necessary capture velocity at the nozzle entrance, with one third the air flow rate of its predecessors. Since power consumption is roughly proportional to the cube of the flow rate, the Leaf Slayer can clean the same amount of debris using less power.

In addition to lower power requirements and more effective cleaning, less down time will be needed to clear clogged ductwork and clean the collection device. This is made possible by the vacuum system on the Leaf Slayer. After being vacuumed into the nozzle, the debris is

conveyed through a minimum of ductwork and deposited directly from the fan to the collection hopper. As the vacuum system of the Leaf Slayer uses less ductwork and has fewer bends than similar machines, there are fewer places for debris to accumulate and block the system. This saves the customer time, as work can continue without stopping to clear a blockage.

Another advantage of the Leaf Slayer's vacuum system is that the centrifugal fan shreds the debris (reduces its volume) before exhausting it to the hopper. This has two benefits, first, it allows more area to be cleaned before the collection device must be emptied. Second, the shredded debris will occupy less space during transport to land fills.

The Market

While doing research at lawn and garden dealers, it became obvious that a large market existed for quality debris cleaners. Table 1 shows the number of entities, in the United States, known to use such equipment.

*Note: A larger market exists in Europe, however, market data on this area is not yet available.

Table 1 Results of Preliminary Market Analysis	
	<u>Number in US</u>
Air ports	18,212
National Parks	369 (80.7 million acres)
Four Year	1,255
Universities	
Golf Courses	13,000

Different segments of the market can be catered to with a modular machine. For instance, one could satisfy different customers by simply improving or adding on the needed features. A chipper-shredder and mower deck are possible options. If necessary, the Leaf Slayer can be scaled down for home owners who require a smaller, less expensive version of the machine, or scaled up for cleaning of large areas such as National Park lawns.

The Plan

It is the hope of the inventors to take the Leaf Slayer from the experimental stage to a product, thereby creating jobs to bolster the economy. To do so, an industrial partner is being sought to sponsor the Beta prototype and final production model. The Beta prototype would be tested on M.I.T. grounds, military bases, and possibly the White House lawn. During this testing time, work would continue on the final production model which would be ready for market by next summer.

What we wish to accomplish:

Deliverables of the project include:

- M.S. Thesis for Martin Culpepper
- Production model of a debris cleaner
- Demonstration of dual-use technology for the NRL
- New Jobs
- Funding for Educational Programs

Second Brochure



The Leaf Slayer



Inventors: Prof. Alex Slocum
slocum@mit.edu

Martin Culpepper
mculpepp@mit.edu
(617) 253 - 2407

Sponsored By: -Naval Research Laboratories
-GEM
-Briggs and Stratton
-Eaton Corporation

Developed at The Massachusetts Institute of Technology



Precision Engineering Research Group
<http://pergatory.mit.edu>

Ask yourself: What would your customers like in a lawn machine?

How about a machine which:

- uses less power/gas than similar machines
- produces less noise (uses a smaller engine)
- is self cleaning
- can clean without damaging lawns
- has a modular design, allowing for user customization

The Leaf Slayer covers all of the above. Before we explain, let us consider who would be interested in purchasing such a machine.

Who would use a Leaf Slayer?

Table 1 shows entities known to use equipment such as the Leaf Slayer. There is also a large market for home owners and small businesses.

	<u>Number in US</u>
Air ports	18,212
National Parks	369 (80.7 million acres)
Four Year Universities	1,255
Golf Courses	13,000

* A larger market exists in Europe, however, data on this area is not yet available.

Meet the Leaf Slayer

The design of our Alpha prototype is shown in Figure 1. The Leaf Slayer is composed of a frame, self cleaning hopper, fan, hydraulic power system, and a compound auger. What makes the Leaf Slayer

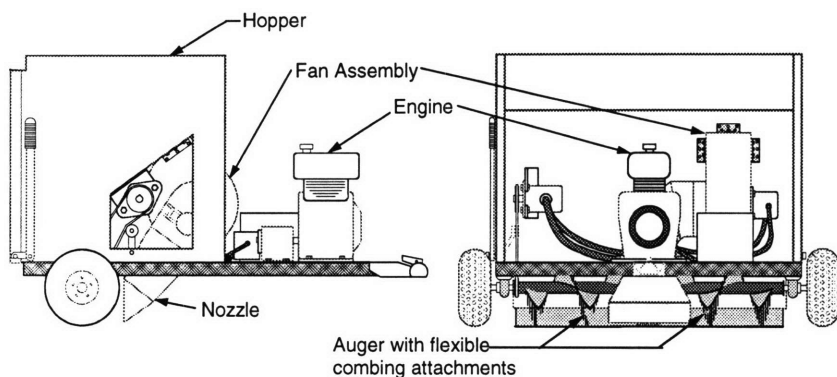

Figure 1

better than the rest, is the way in which it dislodges and collects debris. Instead of using a rotary brush as sweepers do, the Leaf Slayer uses a compound central discharge auger. This compound auger consists of a rigid inner auger with combing attachments fastened along the edge of its flighting (see Figure 2). Unlike the stiff rotary brushes on lawn sweepers, the combing attachments on the Leaf Slayer are designed to dislodge embedded debris (such as leaves in heavy grass) without damaging the surface. During operation, the debris accumulates in front of the auger, is conveyed to a central area by the auger, then is vacuumed through the nozzle.

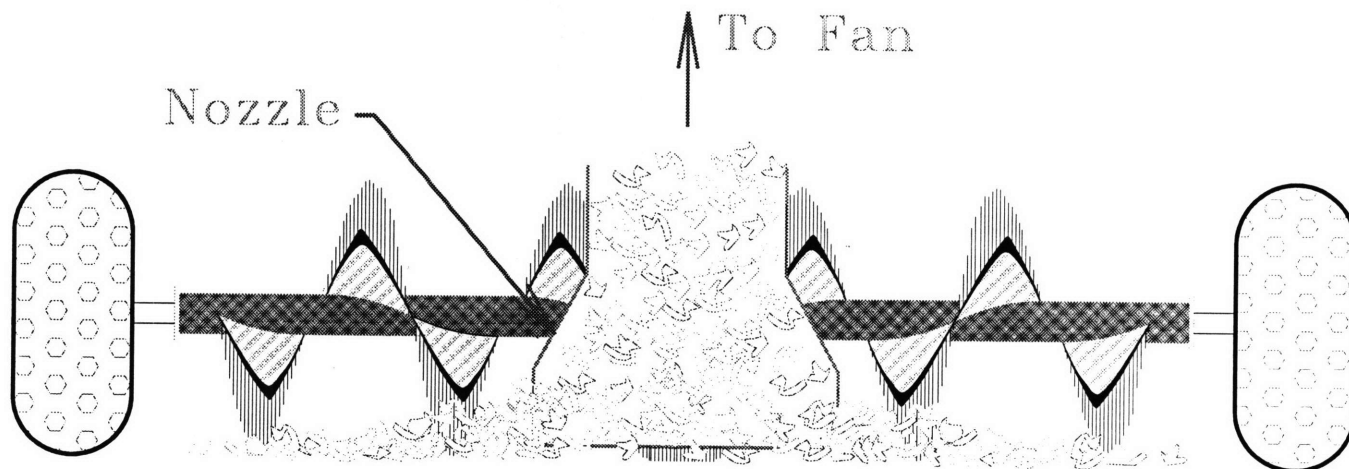

Figure 2

The benefit of this is best described using Figure 3. The power required to run the vacuum system depends on the cube of the nozzle size. Figure 4 is a graphical illustration of this relation for a typical application**. Note the drop in power required by the vacuum system for a decrease in nozzle width.

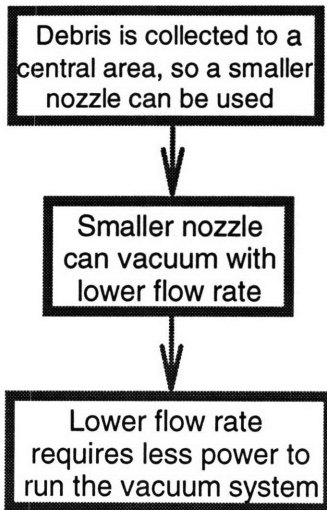

Figure 3

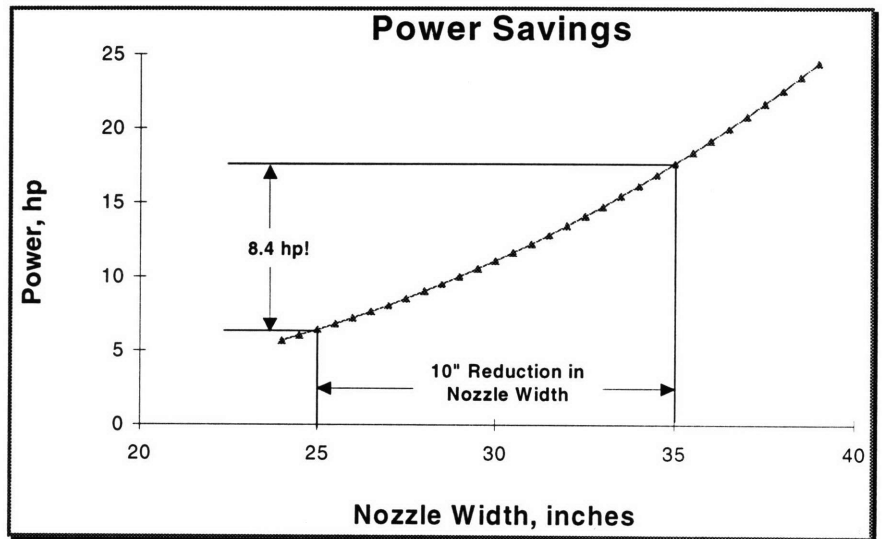
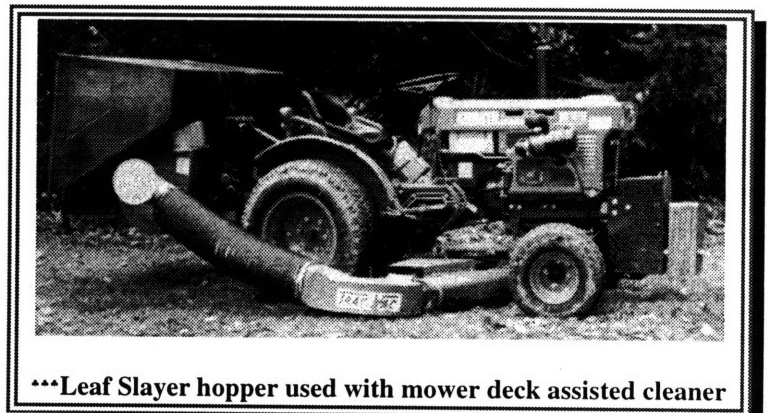

Figure 4

Extras

The Leaf Slayer can be scaled to match the size of the job; from the lawn of an ordinary home, to the fairways of a golf course. In addition, the modular design allows the owner to tailor the machine, or its components, to their needs. For example, one could add a mower deck, chipper shredder, manual vacuum hose (for vacuuming in tight spots), or any



*****Leaf Slayer hopper used with mower deck assisted cleaner**

combination of the above. Also, if one component of the machine, such as the hopper, catches your eye. Then we can custom design it for your system***. These features will make the Leaf Slayer an attractive addition to your product line. We want to work with you to customize a final design and maximize your Leaf Slayer manufacturing ability. Please contact us at **617-253-2407** for more information.

** Curve shown assumes a typical “density” or “thickness” of debris cover. For applications with thicker debris cover, the curve will shift upwards slightly.

Example Confidentiality Agreement, This is meant only as an example, seek legal advice before signing this or any other agreement!

CONFIDENTIALITY AGREEMENT

This agreement relates to the exchange of proprietary information between

Martin Culpepper

AND

(CULPEPPER)

(RECIPIENT)

CULPEPPER may disclose proprietary information relating its business plans and technical designs for contemplated new machinery relating lawn and similar large-area leaf and debris-vacuums.(collectively DATA).

This exchange of information is to allow both parties to evaluate the feasibility of evaluating designs and potential cooperative development and commercial relationships.(the PURPOSE).

RECIPIENT and CULPEPPER agree to hold in confidence DATA revealed by the other party. The parties will use DATA disclosed to them only for the PURPOSE and will not knowingly disclose the DATA to any third party without the prior written consent of the disclosing party. In addition, during the period of confidentiality, each party will protect DATA disclosed by taking reasonable precautions to avoid disclosure which are at least as restrictive as the precautions it uses to protect its own proprietary data.

The obligation of confidentiality shall apply regardless of the form the DATA takes. To be protected under this agreement, all documents containing DATA will be conspicuously marked with a proprietary legend at the time of delivery to the other party. DATA disclosed orally or in any form other than a document will be identified as proprietary at the time of disclosure and then described in a writing, suitably marked proprietary, and mailed to the receiving party within 30 days of the disclosure.

The obligations of confidentiality shall not apply to information that:

- (a) is or becomes publicly available otherwise than as a result of actions of the receiving party;
- (b) is, prior to disclosure under this agreement, already in possession of the receiving party;
- (c) is rightfully received by the receiving party from a third party without obligation of secrecy;
- (d) is disclosed by commercial activities of the originating party or by commercial activities of the receiving party authorized by the originating party; or
- (e) is independently developed by the receiving party.

This agreement shall not be interpreted as creating any of the following obligations or relationships: partnership or joint venture, license of rights in the DATA; any obligation to disclose information; any warranty of any kind with respect to the data or its use.

This agreement may be modified only in writing, signed by both parties.

This agreement shall be effective for one year. Either party may terminate this agreement sooner with 30 days written notice to the other party. The obligation of confidentiality will survive termination of

this agreement, but the receiving party will have no liability for inadvertent use or disclosure of information which occurs more than five years after the date of this agreement.

This agreement shall be construed and the legal relations of the parties determined in accordance with the laws of the Commonwealth of Massachusetts.

ACCEPTED AND AGREED:

CULPEPPER

RECIPIENT

by: _____

by: _____

Name: _____

Name: _____

Title: _____

Title: _____

Date: _____

Date: _____

Script to *Leaf Slayer* Video

Following is the script of the Leaf Slayer video which was sent to interested parties. To make a script, first list the things you want to show, then find or record them. Time the intervals on the tape, and write your script accordingly.

Introduction

Pan across lawn, showing field full of oak Leaves

My name is Martin Culpepper, graduate student and co-developer of the leaf slayer. The *Leaf Slayer* is a debris cleaner developed as part of my thesis work at MIT. Before we begin, you should know that the objectives of my thesis include first, to design and test a product and second, to bring the product to market with the help of an industrial sponsor. This video has been sent to you in hopes that it will peek you interest in becoming an industrial sponsor. With that, I present to you the alpha prototype of the Leaf Slayer.

Fade to black

Fade in picture of leaf slayer running in place

Circle machine, showing various components

The Leaf Slayer uses a novel system to efficiently collect debris. The pieces of debris are collected by a central discharge auger with compliant-combing attachments. The attachments dislodge pieces of debris from the grass. The auger then conveys the debris to the middle of the machine where a nozzle vacuums them up. The main benefit of this design is that the pieces of debris are gathered to a common location. As such a smaller nozzle can be used to vacuum them up. As the power required by typical vacuum systems is roughly proportional to the cube of the nozzle size, significant power savings can be obtained by using a smaller nozzle.

In the following video, you will see three test runs of the machine over a field of mildly damp oak leaves. We have picked oak leaves as they are the hardest to collect. After each test, the oak leaves are removed from the machine and re-spread for the next test.

Run A

We first start by setting a baseline so that you may see the effect of the auger. To do this, the fan and vacuum system are engaged while the compound auger is inactive.

While this test is being run, I will explain one feature of the machine, the collection hopper. This component of the machine is made from folded pieces of sheet metal. The structure is self supporting with out the use of a frame. The structure also holds itself in place during assembly so that no fixturing is need to position the pieces for fastening. For in house assembly this can reduce fixturing cost. This design is also attractive for manufacturers who ship cleaners with unassembled hoppers, as this feature makes it easier for the customer to assemble.

Fade to black

Fade in test B

Run B

In the second run, we engage both the vacuum system and the compound auger. From our tests, we leered that our machine was too wide. As a result, debris lying in depressions in the lawn are missed by the auger. To remedy this, we are designing a narrower machine, possibly with a flexible auger which is better able to follow the contour of the ground.

We have also learned that our choice of pitch for the auger was too small for debris such as leaves. As a result, this has limited the conveying rate of the auger and thus the speed at which the alpha prototype can be pulled through a debris field. Our attempts to increase the conveying rate of the auger by increase its rotational speed were unsuccessful. If the speed of the auger is increased much beyond the speed at which this test is run, the attachments carry the leaves over the top of the auger and throw them behind the machine. To solve this problem we have

designed a trough to enclose the rear half of the auger. In this position, the trough will prevent debris from being thrown behind the machine when the auger speed, or conveying rate is increased. In conjunction with this, we propose to change the pitch of the auger to increase the flow rate.

Fade to black

Fade in run C

Run C

In the third run, we increase the speed of the tractor and slightly increase the speed of the auger.

It is important that the viewer realize, that our purpose in this video is to show proof of concept. Today you have seen that some optimization must take place, however, we believe the challenges in doing so are not insurmountable. By making the simple adjustments and design changes noted during the previous run, the performance of the machine should increase dramatically.

This concludes the first portion of our video. In the next, we show a short clip of the second prototype of the leaf slayer.

Fade to black

Fade in second prototype

You are viewing the second prototype of the Leaf Slayer. For this prototype, we have connected our patent pending hopper to the three point hitch of a lawn tractor. A flexible duct runs from the outlet of the tractor's mower deck to a fan mounted on the underside of the hopper.

Power is delivered to the fan via a gear box which is coupled to the tractor PTO. Note that the fan could also be run by an on-board hydraulic system, or by the tractors hydraulics.

What you have seen is use of the original Leaf Slayer hopper as a component of another debris cleaner. The hopper could also be used with a sweeper. If desired, the auger concept shown in the first portion of the video can be used with your collection device and or mower deck.

There are many different options and we are sure you have questions. We want to work to make a final design of the Leaf Slayer or its components which meets your needs. Please call me, Martin Culpepper, at 617-253-2407 for discussion or more information.

Fade to black

Example Presentation

The presentation given to Ingersoll, is included here as an example. The presentation, done in Power Point™, was pasted into this document in compressed form. Ideally, an overhead would be printed in landscape format, using the entire page.

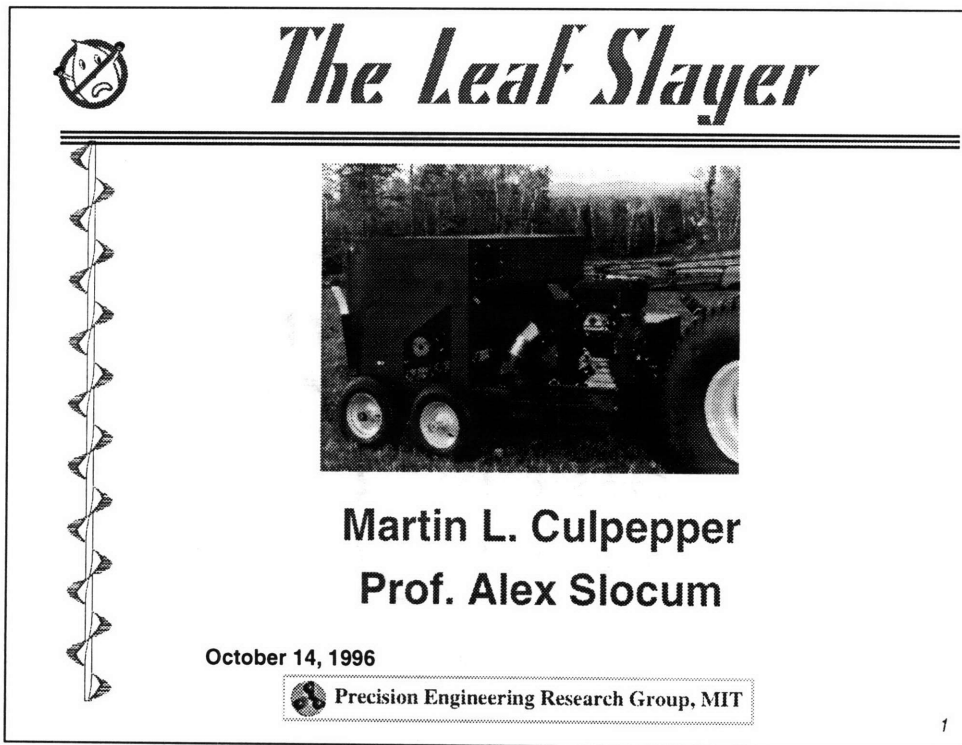

Opening Slide with title of presentation and names of those presenting, or to be recognized.



Road Map

- Introduction
- Leaf Slayer Design
- Benefits
- Marketing
- Options
- MIT Research Lab
- Questions/Comments

 Precision Engineering Research Group, MIT

2

List of what the presentation will be about.



In The Beginning

Humble Grad Student

Brilliant Professor



- Product/Market Thesis
- Conceptualize
- Proof of Concept
- Industrial Sponsor

 Precision Engineering Research Group, MIT

3

Background needed to familiarize the audience with the project.



Meet The Leaf Slayer

- ▣ Idea
- ▣ Concepts
- ▣ Models
- ▣ Design
- ▣ α Prototype
- ▣ β Prototype
- ▣ Production



- Compound Auger
- Variable Hydraulics
- Self Cleaning Hopper



Precision Engineering Research Group, MIT

4

Description of the invention and current status of the project.



Compound Auger

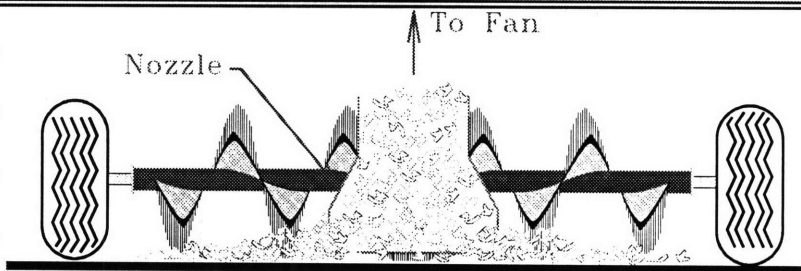

- ▣ Flexible Combing Attachments Lift
- ▣ Rigid Inner Core Auger Conveys

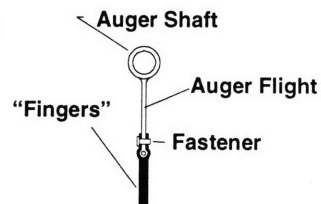

Precision Engineering Research Group, MIT

5

Illustration showing how the device works.



Power Savings

Over Estimation!

Assumptions

- ▣ Fluid Density
- ▣ Loss Factors
- ▣ Nozzle Depth

Fan Power

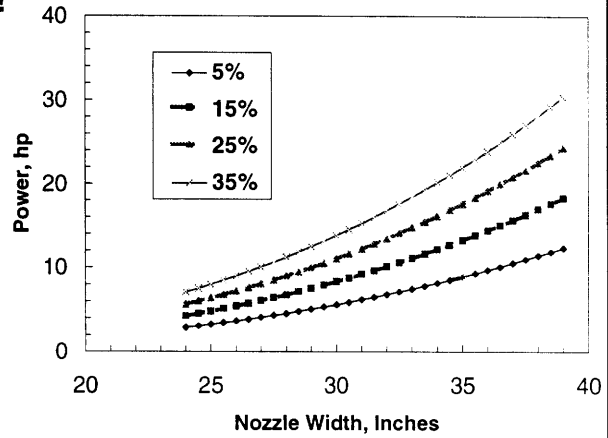

Precision Engineering Research Group, MIT

6

Benefit of the design.



Hopper

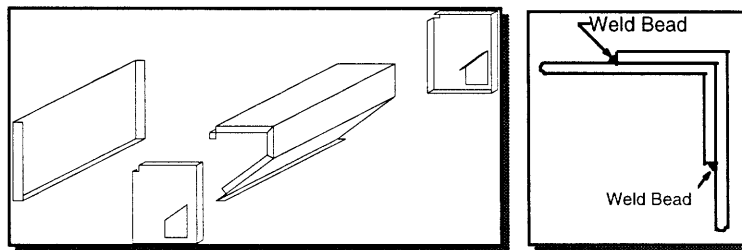

- ▣ Essentially forms an angle frame at lap joints
- ▣ Easier to make
- ▣ Less expensive to make

Precision Engineering Research Group, MIT

7

Benefits continued.....



Marketing

Potential Markets

	<u>Number in US</u>
Airports	18,000
National Parks	369 (80M)
Universities	1,250
Golf Courses	13,000

- ☛ Small Business
- ☛ Maintenance Firms
- ☛ Home Owners
- ☛ ATV Owners

 Precision Engineering Research Group, MIT

8

Type of customers who may buy the item.



Our Cost (approximate)

Major Components

Auger	\$ 600
Engine	\$ 500 (donated)
Hopper & Frame	\$ 350
Hydraulics	\$ 1500 (pump and motor donated)
Other	\$ 800
$\Sigma=$	\$3750

Gravely Pro Vac [®]	\$6800
Toro Rak-O-Vac [®]	\$8000

 Precision Engineering Research Group, MIT

9

Rough cost of prototype, and comparison to cost of other debris cleaners.



Options

- Mower Deck
- Auxiliary Hose
- Scale
- Chipper Shredder
- Sweeper
- Vacuum
- Multiple Fingers

 Precision Engineering Research Group, MIT

10

Alternatives and modular pieces of design.



Review

- Compound Auger Design
- Variable Hydraulics
- Self Cleaning Hopper
- Power Savings
- Market
- Cost
- Options/Modularity

 Precision Engineering Research Group, MIT

10

Recap of what was covered.

Appendix B

Patent Material

The complete patent application is presented as an example. Figures follow the application.

DEBRIS CLEANER WITH COMPOUND AUGER AND VACUUM PICKUP

Statement Regarding Federally Sponsored Research

This invention was made with government support under Contract No. N00014-95-1-G039 awarded by the Department of the Navy. The government may have certain rights in the invention.

Technical Field

This invention relates to debris cleaners for cleaning material such as leaves and paper from small or large properties such as lawns, golf course greens, parking lots, and airfields.

Background Information

Some known lawn vacuums, such as the Gravely Pro Vac 1050, have a vacuum nozzle which extends across the width of the machine, and thus a high flow rate is needed to maintain a sufficient capture velocity at the nozzle entrance. To reduce the required flow rate, the area of the nozzle entrance can be reduced. Known lawn vacuums with reduced-area nozzles have a high width to depth ratio and thus have high loss from entrance effects and increased perimetral area. The reduced-area nozzles of these lawn vacuums extend across the width of the machines. These known lawn vacuums use large amounts of power. In addition, they generally are not able to dislodge embedded or wet debris from a surface such as a formal lawn. They also have long runs of ductwork which can become clogged with debris, and this causes down time as the machine must be shut off to clear the blockage.

Debris cleaners having brush pick up devices, known as sweepers, use one or more rotary brushes rotating at high speed to dislodge debris from the ground and propel it into a collection device. Sweepers are manufactured by, for example, the Toro Company. The Toro Company has the following models of sweepers: 44020, 44040, 44045, 44050, 44055, 44081, 44083, 44085, and 44089. Unlike the vacuum devices mentioned in the preceding paragraph, sweepers do not pass debris through a fan where its volume is reduced by shredding, and this increases the down time of sweepers as the debris-collecting hoppers on the sweepers must be emptied often. Also, the brushes must be rotated quickly to impart sufficient momentum to propel dislodged debris from the ground some distance into the hopper, and the fast moving brushes often damage delicate surfaces, such as formal lawns or golf course greens.

Some known machines combine aspects of sweepers and lawn vacuums. For example, a cleaner described in U.S. Patent No. 2,809,389 has an axial fan, a system of ductwork, and a rotary sweeper brush. Problems with this cleaner include the fact that: the operating speed of the axial fan is limited to a range in which it will not stall; the axial fan must rotate at dangerously high speeds to achieve the static pressure needed for debris cleaning; and large

amounts of power are required because the nozzle extends across the width of the cleaner as it does with known lawn vacuums. The Toro Rake-O-Vac combines brush and vacuum features, and it has power problems because the nozzle extends across the width of the machine. The device described in U.S. Patent No. 4,615,070 has the same power problems experienced by known lawn vacuums because the brush has no centralizing feature and the nozzle extends across the width of the device. Also, the device has a brush sweeper with dense-packed bristles (for fine dirt collection) which would severely damage lawn surfaces and quickly become clogged with leaves.

Some known machines combine rotary brush and auger features. For example, the debris cleaners described in U.S. Patent No. 4,393,537 and U.S. Patent No. 3,695,716 use a rotary brush and a separate auger. The brush propels debris to the auger which then transports the debris to a desired location. These debris cleaners are not designed to remove debris from delicate surfaces, and they would cause damage to such surfaces. In addition, cost and complexity are added to the design as these cleaners have two separate rotary elements, the brush and the auger.

Some known debris cleaners are designed to work in conjunction with mower decks. Examples are Trac-Vac deck attachments and Ingersoll's Hydra Vac. With these cleaners, a mower blade lifts and shreds the debris, and a fan then blows the shredded debris through a long flexible duct into a pull-behind hopper. As with lawn vacuums, down time occurs often because the long flexible duct is prone to clogging. In addition, such designs require the use of a companion mower deck, and this may not be practical in many situations such as when used with all terrain vehicles which must use a rear mower deck.

Some known cleaning devices, such as upright vacuum cleaners and the apparatus disclosed in U.S. Patent No. 5,427,573 and U.S. Patent No. 3,813,720, use a type of auger brush for cleaning. These designs generally do not perform well on delicate surfaces such as a formal lawn because the bristles are either too stiff and thus damage the surface or too soft to convey the material.

Augers with components attached to their flighting or housings are known. For example, in U.S. Patent No. 4,322,896, a strip of anti-friction material is attached to the edges of a snow blower auger which is in direct contact with the ground. The auger spins between 1300 and 1500 revolutions per minute. Residual friction between the attached strips and ground provides the force to propel the machine. This modification makes the machine self-propelled. Such designs generally are not be able to comb and lift embedded debris from delicate surfaces such as formal lawns, and the fast moving attachments will damage such surfaces. Another auger design is described in U.S. Patent No. 2,397,305 as having a strip of wiping material attached to the edge of the auger flighting. This design generally can not effectively remove embedded debris from delicate surfaces, and it will damage such surfaces. In U.S. Patent No. 4,203,237, a snow blower uses elastomeric auger flights attached to a drum. This design is ineffective in removing embedded debris, and it also is hampered by the fact that, like an upright vacuum cleaner, the spiraling members are attached to the outer edge of a drum. Use of a drum takes up space within the area of influence of the auger, and thus it reduces the effectiveness with which the auger or auger brush can convey solids. Also, the flights are designed to be stiff enough to offer sufficient resistance to heavy snow, and the use of these stiff

flights on a delicate surface such as a lawn will cause damage to the grass and underlying surface. As described in U.S. Patent No. 4,477,989, it is known to attach scarify teeth to the edge of snow blower auger. The teeth cut into packed snow to make it easier to convey the snow. This design would not work on delicate surfaces such as a formal lawn because the teeth would cause damage to the surface and the grass. In U.S. Patent No. 3,673,715, raking tines are attached to the shaft of a snow blower auger, and the tines dislodge debris which is then transported by the auger to the snow blower discharge. Although the tines can remove embedded debris from a lawn, the stiff tines and rigid auger blade would dig into the ground on uneven terrain and, as such, the device is not suitable as a debris cleaner. It is known to add a rotary rake and a collection bag to a snow blower, as described in U.S. Patent No. 3,999,316. The rake dislodges material from the grass, and the dislodged debris is then conveyed by the auger to a fan which vacuums up the debris and deposits it into a collection bag. With this design, two rotary elements are needed to clean debris, and a skid located under the auger to prevent the auger from contacting the ground is used and positioned such that it could run into high spots on rolling terrain.

In general, known cleaners do not perform up to expectations. They generally are cumbersome to operate and inefficient with respect to power consumption.

Summary of the Invention

This invention relates to a device for cleaning material (e.g., leaves, paper, and other debris) from delicate surfaces such as lawns and golf course greens and also from harder surfaces such as paved parking lots and airfields. In accordance with the invention, the device consumes less power than known cleaners and is more effective in picking up material that has traditionally been difficult to separate from the surface being cleaned. As compared to known cleaners, the device of the invention minimizes the amount of down time due to ductwork clogging and to repeated emptying of a collection device.

The cleaning device of the invention is equipped with a compound auger which has a rigid inner auger portion and also compliant combing attachments connected to the edge of the auger flighting. The compound auger may be replaced by a helical rotary brush with a dense inner region of bristles and a less populous outer region of bristles. Material properties and dimensions of the compliant combing attachments (or bristles) are chosen so that the surface being cleaned is not damaged during cleaning. The auger is positioned horizontally with its axis of rotation co-linear with (or at least parallel to) an axle of a set of wheels supporting the cleaning device. The arrangement allows the auger to follow the contours of the surface being cleaned just as the wheels follow the contours but without the auger digging into or otherwise damaging the surface. The auger is positioned at a height which allows the outer edges of the compliant combing attachments to contact the surface. As the attachments engage the surface, they dislodge material therein and thereon, and they help convey the material along the axis of the auger to an area in front of the auger and located in the middle of the auger. The material is then drawn into the device, by a vacuum, through a nozzle located above the middle collection area. The cleaning device requires less power to operate than known cleaners because the auger directs the material to the central collection area where a

smaller nozzle can be and is used, and this smaller nozzle requires a lower flow rate to maintain sufficient capture velocities at the nozzle entrance. The material is pneumatically conveyed through the nozzle to a centrifugal fan where it is shredded upon impact with the blades of the fan. The shredded material is then exhausted to a hopper. The hopper can be made from, for example, folded pieces of sheet metal or blow molded fiberglass which when put together form a rigid structure without the use of a dedicated frame. The cleaning device may be used in conjunction with a mower deck or other lawn and garden implements. A flexible hose may be attached to the ductwork of the cleaning device, and the hose can be used to vacuum manually areas impossible or impractical to reach with the auger/vacuum arrangement of the cleaning device. A valve on the side of the ductwork can be used to cut off airflow through the nozzle and direct the suction to the hose. The power provided to the auger and the fan (and any additional implements) is such that the speed of each powered component can be varied independently of the others.

The cleaning device of the invention can dislodge and pickup wet or embedded material from a surface such as a lawn with heavy grass cover. The compliant combing attachments aid in dislodging the material. The attachments may include compliant rubber fingers, a compliant material impregnated with soft bristles or wires, compliant bristles or wires, any combination of such mechanisms, or any other mechanism(s) which cause the desired effect of dislodging material without damaging the surface being cleaned. The dimensions and material properties of the attachments are chosen such that they do not cause damage to the surface.

An advantage of positioning the auger with its rotational axis substantially co-linear with (or at least parallel to) the axis of the wheel-supporting axle, and thus perpendicular to the device's direction of movement over the surface being cleaned, is that the auger will follow the contour of the surface as do the wheels. This prevents the auger from digging into the ground if the device were to pitch severely about the axle. If positioned on any other axis, an additional mechanism would be needed to ensure the proper height of the auger axis during such a scenario, and such a mechanism would add costs and complexity to the design of the cleaning device.

The cleaning device uses a vacuum system to convey material through a minimum amount of ductwork so as to minimize power loss and clogging in the ductwork. A centrifugal fan shreds the material as it comes into contact with the blades of the fan. The fan then exhausts the shredded material directly into a collection hopper, thereby eliminating the need for extra ductwork between the fan and collection hopper.

The foregoing and other objects, aspects, features, and advantages of the invention will become more apparent from the following description and from the claims.

Brief Description of the Drawings

In the drawings, like reference characters generally refer to the same parts throughout the different views. Also, the drawings are not necessarily to scale, emphasis instead generally being placed upon illustrating the principles of the invention.

FIG. 1 is a side view of a debris cleaner according to the invention.

FIG. 2 is a front view of the debris cleaner of FIG. 1.

FIG. 3 is a top view of the debris cleaner of FIG. 1.

FIG. 4 is a bottom view of the debris cleaner of FIG. 1.

FIG. 5 is an exploded view of a collection hopper of the cleaner of FIG. 1.

FIG. 6 is front view of the debris cleaner, partly in section, showing the path debris is conveyed.

FIGS. 7A and 7B are diagrams of a manually-operable valve, in closed and opened positions, for an auxiliary vacuum hose of the cleaner.

FIG. 8 is a diagram of one embodiment of compliant attachments on a rigid core of a compound auger of the cleaner.

FIG. 9 is a diagram of one embodiment of a rotary brush for use in place of the compound auger of the cleaner.

Description

Referring to FIGS. 1, 2, 3, 4, and 6, a cleaning machine 1 according to the invention is supported by wheels 1L, 1R on a horizontal axle 2. The axle 2 is disposed transverse to the direction of travel of the machine 1. A ball hitch 3 is used to attach the machine 1 to a pulling vehicle. Instead of the ball hitch 3, a similar attachment device can be used such as a pin hitch or a three point hitch. Alternatively, the machine 1 can be made self-propelled in which case it would not be necessary to use a pulling vehicle. Atop the front of the frame 4 is a platform 5 which provides a place to attach components of the drive train and other items.

In a preferred embodiment, either an internal combustion engine 6 or the power-take-off of a tractor can be used to power a pump assembly 7 which moves fluid from a reservoir 8 through hydraulic hoses 9 to a system of hydraulic motors in which the speed of any hydraulic motor can be adjusted separately from the others. One hydraulic motor 10 drives a compound auger 11 via a chain or belt 12. An adjustable idler sprocket or sheave 13 is provided to maintain tension in the chain or belt 12. Another hydraulic motor 14 drives the blades 15 of a centrifugal fan 16 directly or via a jack shaft. Other hydraulic motors may be added to drive auxiliary implements via chain or belt drives. In other embodiments, power could be provided to the fan 16 and the auger 11 using a system of clutches, belt drives, and gear boxes or clutches, chain drives, and gear boxes. In such embodiments, the drives would be configured to allow individual adjustment of the speeds of the driven components. All moving components presenting a safety hazard are either covered with safety shields or placed so as to prohibit entry into these areas or at least make entry difficult.

Either a solid, ribbon, or auger brush 11 rotates on bearings which are contained in the ends of the auger shaft or a suitable adapter 17L, 17R, attached to the ends. The horizontal, rotational axis of the auger 11 preferably is common with the axle 2 of the wheels such that the auger 11 follows the contour of the terrain. The axis of the auger 11 can be parallel and adjacent to the axle 2, instead of co-linear with it, and still follow the contour of the terrain being cleaned. Flighting 18L, 18R on either end of the auger 11 is of opposite pitch so as to transport debris to an area in front of the auger 11 and midway along its length. Rotation of the auger 11 may be either in the same or opposite direction of the wheels 1L, 1R, depending upon the surface being cleaned and the flighting 18L, 18R of the auger. The flighting is disposed around the core of the auger 11 in a generally helical or spiral fashion as shown. Both the flighting and the core of the auger 11 preferably are made of a rigid material or rigid composition of materials. Rigid metal or polymer can be used for the flighting and the core of the auger 11.

The auger 11 is referred to as "compound" because fastened along the length of the edge of the rigid auger flights 18L, 18R are compliant combing attachments 19 capable of dislodging debris from a surface such as a lawn with heavy grass cover without damaging the surface. The attachments 19 also aid the rigid flights of the auger 11 in conveying the debris along the auger's axis of rotation to a midpoint where it can be vacuumed up by a suction device placed at that midpoint. An illustration of a possible way to connect the attachments is shown in FIG. 8 and FIG. 9. The attachments 19 can include, but are not limited to, compliant rubber fingers, a compliant material impregnated with soft bristles or wires, compliant bristles or wires, any combination of such mechanisms, or any other mechanism(s) which cause the desired effect of dislodging debris without damaging the surface being cleaned. The dimensions and material properties of the attachments 19 are chosen such that the attachments 19 offer sufficient resistance to the surface and debris so that effective cleaning results without damage to the surface. Materials which can be used for the attachments 19 include elastomers such as rubber. In general, any material that allows the attachments 19 to perform as described herein can be used.

The auger 11 is positioned substantially coaxial with the axle 2 of a supporting set of wheels so that clearance between the ground and the rigid portion of the auger 11 is kept fairly constant on flat or rolling terrain. This allows the compliant combing attachments 19 to be optimized for a minimum length at which sufficient resistance results to comb debris and aid the rigid portion of the auger 11 in large volume conveyance of material to the central collection area at the midpoint of the length of the auger 11 where a nozzle 22 is located.

A trough 20, attached to the frame 4 by its ends, partially encloses the auger 11. A portion of the trough 20 in front of, and along the length of, the auger 11 is left open to allow debris to contact the auger flighting 18L, 18R and the attachments 19. A compliant strip of material 21a, such as an elastomer, attached along the rear edge of the trough 20 provides a moving seal which conforms to the terrain being cleaned and prevents debris from exiting the rear of the machine 1.

The debris is vacuumed into the nozzle 22 supported by the fan 16 inlet via a 90° elbow 23. The entrance to the nozzle 22 is placed slightly above and in front of the area in which the debris has been collected. As with the

rear edge of the trough, a similar compliant strip of material 21b is attached to the perimeter of the nozzle 22 entrance so as to extend the influence of the nozzle 22 close to the ground without danger of the rigid nozzle 22 hitting high spots in the terrain. The nozzle is positioned such that sufficient velocities for capturing debris are maintained in front of the collection area. Referring to FIGS. 7A and 7B, a flexible hose can be attached to an adapter 24 on the side of the 90° elbow 23 where a door 25, when opened (FIG. 7B), will close off the air flow from the nozzle and draw debris through the flexible hose and into the elbow 23. This feature is provided for removal of debris in areas which are impossible or impractical for the machine 1 to clean.

The fan 16 is attached directly to the collection hopper 26. This allows the debris to dump directly from the outlet of the fan 16 into the collection hopper 26, thereby eliminating extra duct work in which power loss or clogging can occur. The fan 16 is powered via a jack shaft or hydraulic motor 14 as discussed previously. The blades 15 rotate at a speed sufficient to move the required air flow rate and shred debris upon contact with the blades 15. The shredding reduces the volume of the vacuumed debris before it is deposited into the collection hopper 26.

In one embodiment of the cleaning machine 1, the power consumption of the fan 16 is about 55% to 75% less than that of conventional debris cleaners, and the blades of the fan 16 rotate at a speed of about 1800 to 4000 rotations per minute.

The hopper 26 is attached to the rear of the frame 4 above the axle 2. The lower edge of the main body 27 is set at an angle which results in the hopper 26 being self-emptying upon opening of the door 28. Ridges 29a, 29b formed in the material of the upper rear portion of the main body 27 help make the hopper 26 rigid and furnish a place to hinge the door 28. Holes are cut in the side panels 30L, 30R to allow access to components of the machine 1 between the side panels 30L, 30R and below the lower edge of the main body 27. A vent 31 in the upper surface of the main body 27 filters debris particles out of the exhausted air.

The hopper 26 is made from pieces of folded sheet metal. It also is possible to mold the entire structure, or its components. Referring to FIG. 5, the bent edges of the side panels 30L, 30R are slid over the edges of the main body 27 until the bent edges of the main body 27 lie flush against the flats of the side panels 30L, 30R. When joined together, the folded edges of the main body 27 and side panels 30L, 30R essentially form an angle-iron frame where the bends of the side panels 30L, 30R and hopper main body 27 meet. This provides a strong, rigid structure without the use of a separate structural frame.

A door 28 is hinged to the horizontal ridge 29a on the upper rear of the main body 27. The bent edges on the door 28 overlap the rear of the side panels 30L, 30R and main body 27, thereby sealing off the enclosure. The door 28 is locked and unlocked by turning a handle 32 which operates two latches 33L, 33R at the lower rear of the hopper 26.

Additional description of the preferred auger design is provided below. A description of an auger brush which can be used in an alternative embodiment of the cleaning machine 1 according to the invention is also provided below.

In general, two limits control the design of the auger. On one extreme, a hard auger will gouge and damage the surface being cleaned. On the other extreme, bristles that are too soft will not collect and centralize the debris for the suction device. In addition, such soft bristles would have to be long in order to extend the radial influence of the bristles so that sufficient volumes of debris could be conveyed. The solution lies between these two extremes. In accordance with the invention, the combination of the rigid inner core part and flights of the auger 11 and the compliant combing outer attachments 19 serves: to dislodge debris from a surface without damaging the surface; to deliver a substantial portion of the dislodged debris to the inner flights of the auger 11 for material conveyance along the length of the auger 11; and to aid in that conveyance along the length of the auger 11. The auger 11 is positioned substantially coaxial with the axle 2 of the supporting wheels so that clearance between the ground and the rigid portion of the auger 11 is kept fairly constant on flat or rolling terrain. This allows the compliant combing attachments 19 to be optimized for a minimum length at which sufficient resistance results to comb debris and aid the rigid auger 11 in large volume conveyance of material to the central collection area located at the entrance to the nozzle 22.

In an alternative embodiment, the auger 11 and attachments 19 are replaced with a rotary brush made in the following manner. Referring to FIG. 9, two types of bristles or fingers 34, 35 could be arranged in a spiral fashion around the periphery of a shaft or drum 36. The shorter, stiffer bristles or fingers 34 form essentially an auger flight around the drum 36. The longer, more compliant brushes or fingers 35 function the same as the compliant attachments 19 which were added to the rigid flights of the compound auger 11.

Variations, modifications, and other implementations of what is described herein will occur to those of ordinary skill in the art without departing from the spirit and the scope of the invention as claimed. Accordingly, the invention is to be defined not by the preceding illustrative description but instead by the spirit and scope of the following claims.

What is claimed is:

Claims

1. A cleaning device comprising:
 - (A) an auger including
 - a rotatable core with a first end and a second end,
 - flighting around the core between the first and second ends, and
 - compliant combing attachments along the edge of the flighting; and
 - (B) a suction device with a nozzle at the midpoint of the length of the core;
whereby, when the core is rotated, the compliant combing attachments dislodge material from a surface with which they make contact without damaging the surface and the dislodged material is conveyed by the auger to the midpoint of the length of the core where it is vacuumed into the nozzle by the suction device.

2. The cleaning device of claim 1 wherein the axis of rotation of the auger is transverse to the direction of movement of the cleaning device over the surface.

3. The cleaning device of claim 2 further comprising wheels on which the cleaning device rolls as it moves over the surface, wherein the movement is caused by the cleaning device being towed or the cleaning device having a source of power for driving the wheels.

4. The cleaning device of claim 1 wherein the compliant combing attachments comprise fingers.

5. The cleaning device of claim 1 further comprising a collection hopper located adjacent the suction device such that the suction device exhausts material directly into the collection hopper.

6. A cleaning device comprising:
 - (A) an auger including
 - a rotatable core with a first end and a second end,
 - a first flight around the core which extends from about the first end to about the midpoint of the length of the core,
 - a second flight around the core which extends from about the second end to about the midpoint of the length of the core, the first and second flights having opposite pitch; and
 - compliant combing attachments along the edge of the first and second auger flights; and
 - (B) a suction device with a nozzle at the midpoint of the length of the core;
whereby, when the core is rotated, the compliant combing attachments dislodge material from a surface with which they make contact without damaging the surface and the dislodged material is conveyed by the auger to the midpoint of the length of the core where it is vacuumed into the nozzle by the suction device.

7. The cleaning device of claim 6 wherein the axis of rotation of the auger is transverse to the direction of movement of the cleaning device over the surface.

8. The cleaning device of claim 7 further comprising wheels on which the cleaning device rolls as it moves over the surface, wherein the movement is caused by the cleaning device being towed or the cleaning device having a source of power for driving the wheels.

9. The cleaning device of claim 6 wherein the compliant combing attachments comprise fingers.

10. The cleaning device of claim 6 further comprising a collection hopper located adjacent the suction device such that the suction device exhausts material directly into the collection hopper.

11. A cleaning device comprising:

(A) a brush device including

a rotatable core with a first end and a second end, and

a first set of bristles and a second set of bristles which are both disposed spirally around the core between the first and second ends, the first set of bristles being shorter, stiffer, and larger in number than the second set of bristles such that the first set of bristles form an auger flight around the core and the second set of bristles form compliant combing members extending out from the auger flight; and

(B) a suction device with a nozzle at the midpoint of the length of the core;

whereby, when the core is rotated, the second set of bristles dislodge material from a surface with which they make contact without damaging the surface and the dislodged material is conveyed by the brush device to the midpoint of the length of the core where it is vacuumed into the nozzle by the suction device.

12. The cleaning device of claim 11 wherein the brush device comprises:

a first section in which the first and second set of bristles are both disposed spirally around the core and extend from about the first end of the core to about the midpoint of the length of the core; and

a second section in which the first and second set of bristles are both disposed spirally around the core and extend from about the second end of the core to about the midpoint of the length of the core, the bristles in the first and second sections having opposite pitch.

13. The cleaning device of claim 11 wherein the axis of rotation of the brush device is transverse to the direction of movement of the cleaning device over the surface.

14. The cleaning device of claim 13 further comprising wheels on which the cleaning device rolls as it moves over the surface, wherein the movement is caused by the cleaning device being towed or the cleaning device having a source of power for driving the wheels.

15. The cleaning device of claim 11 further comprising a collection hopper located adjacent the suction device such that the suction device exhausts material directly into the collection hopper.

16. An auger comprising:

a rotatable core with a first end and a second end;
flighting around the core between the first and second ends; and
compliant combing attachments along the edge of the flighting.

17. The auger of claim 16 further comprising:

a first section in which the flighting is disposed spirally around the core and extends from about the first end of the core to about the midpoint of the length of the core; and
a second section in which the flighting is disposed spirally around the core and extends from about the second end of the core to about the midpoint of the length of the core, the flighting in the first and second sections having opposite pitch.

18. A brush device comprising:

a rotatable core with a first end and a second end; and
a first set of bristles and a second set of bristles which are both disposed spirally around the core between the first and second ends, the first set of bristles being shorter, stiffer, and larger in number than the second set of bristles such that the first set of bristles form an auger flight around the core and the second set of bristles form compliant combing members extending out from the auger flight.

19. The brush device of claim 18 further comprising:

a first section in which the first and second set of bristles are both disposed spirally around the core and extend from about the first end of the core to about the midpoint of the length of the core; and
a second section in which the first and second set of bristles are both disposed spirally around the core and extend from about the second end of the core to about the midpoint of the length of the core, the bristles in the first and second sections having opposite pitch.

DEBRIS CLEANER WITH COMPOUND AUGER AND VACUUM PICKUP

Abstract of the Disclosure

A debris cleaning device is equipped with a compound auger which has a rigid inner auger portion with auger flighting and a plurality of compliant combing attachments connected to the edge of the flighting. Instead of the compound auger, a helical rotary brush with a dense inner region of shorter stiffer bristles and a less populous outer region of longer bristles may be used. The cleaning device also has a suction mechanism with a nozzle located about at the midway point of the length of the auger (or rotary brush). The auger (or rotary brush) is positioned horizontally with its rotational axis co-linear with, or parallel to, an axle of supporting wheels so that the auger (or rotary brush) follows the contour of the surface being cleaned as do the wheels, thereby preventing the auger (or rotary brush) from digging into uneven terrain. The auger (or rotary brush) is positioned at a height above the surface which allows the outer edges of the compliant combing attachments (or longer bristles) to contact the surface. As the attachments (or longer bristles) engage the surface, they dislodge material and help convey it along the axis of the auger (or rotary brush) to a central collection area in front of the auger (or rotary brush) where the nozzle is located. The material is then drawn in through the nozzle by the suction mechanism. The pneumatically conveyed material is then shredded by a fan and exhausted to a collection hopper.

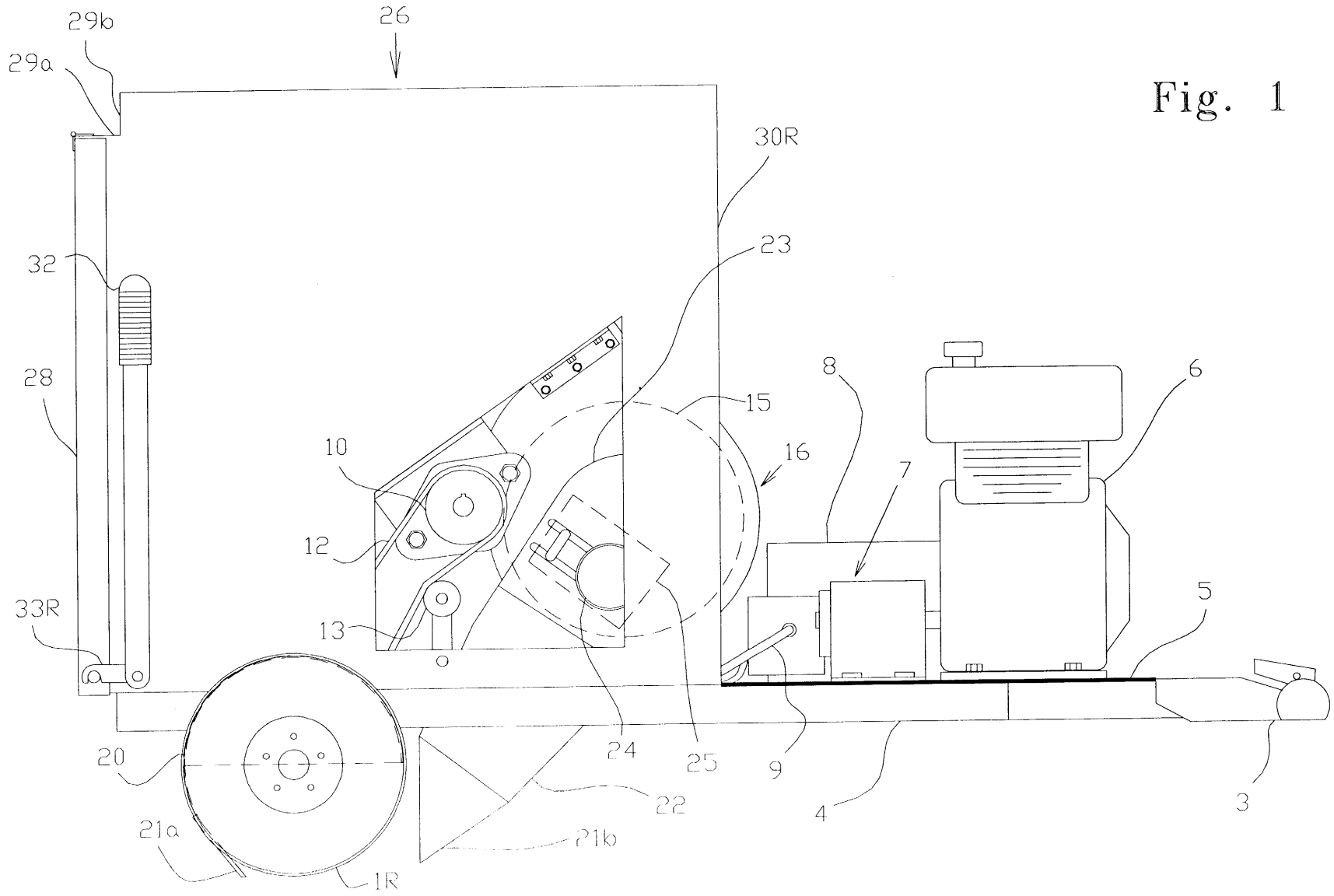

Fig. 1

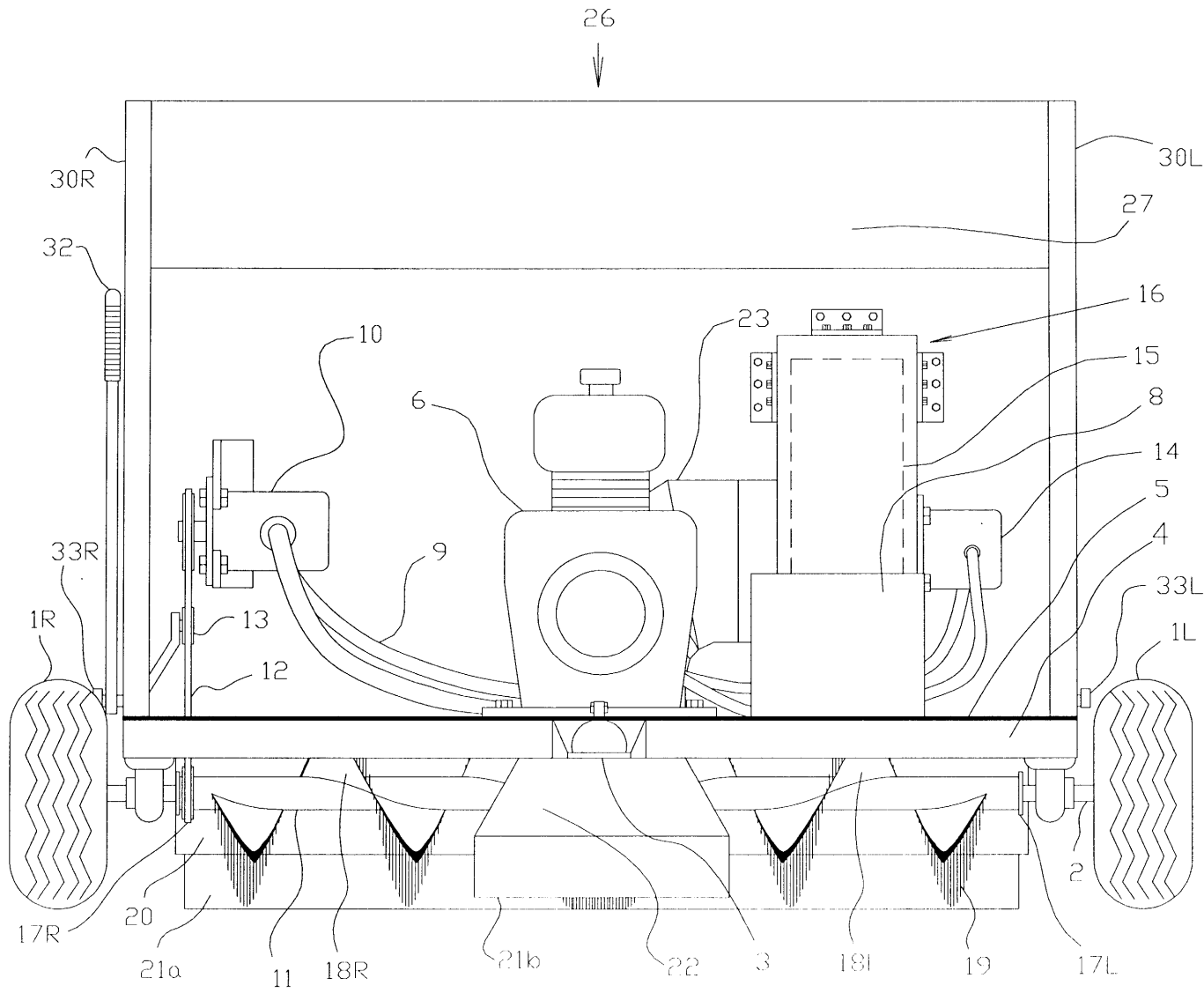

Fig. 2

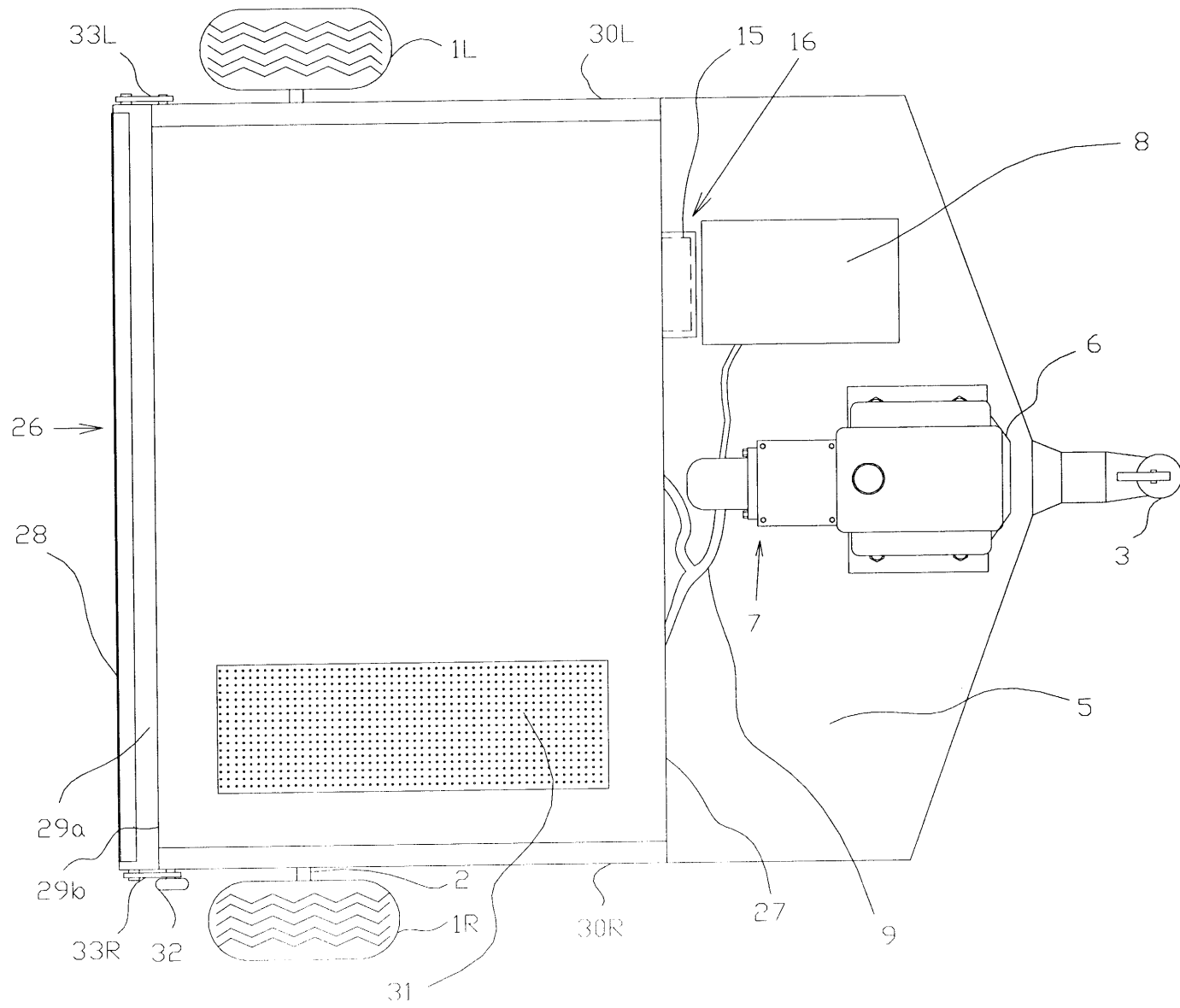

Fig. 3

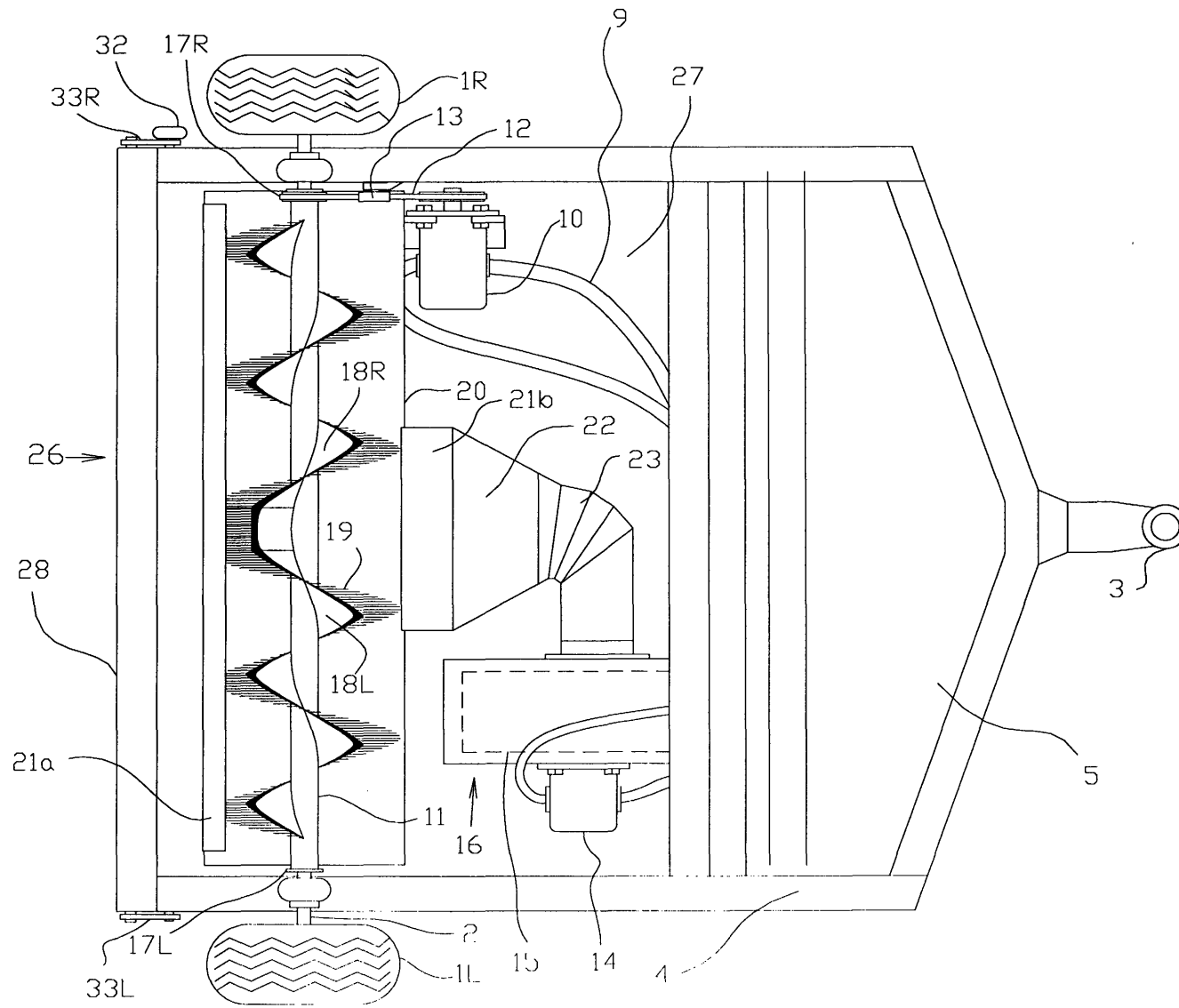

Fig. 4

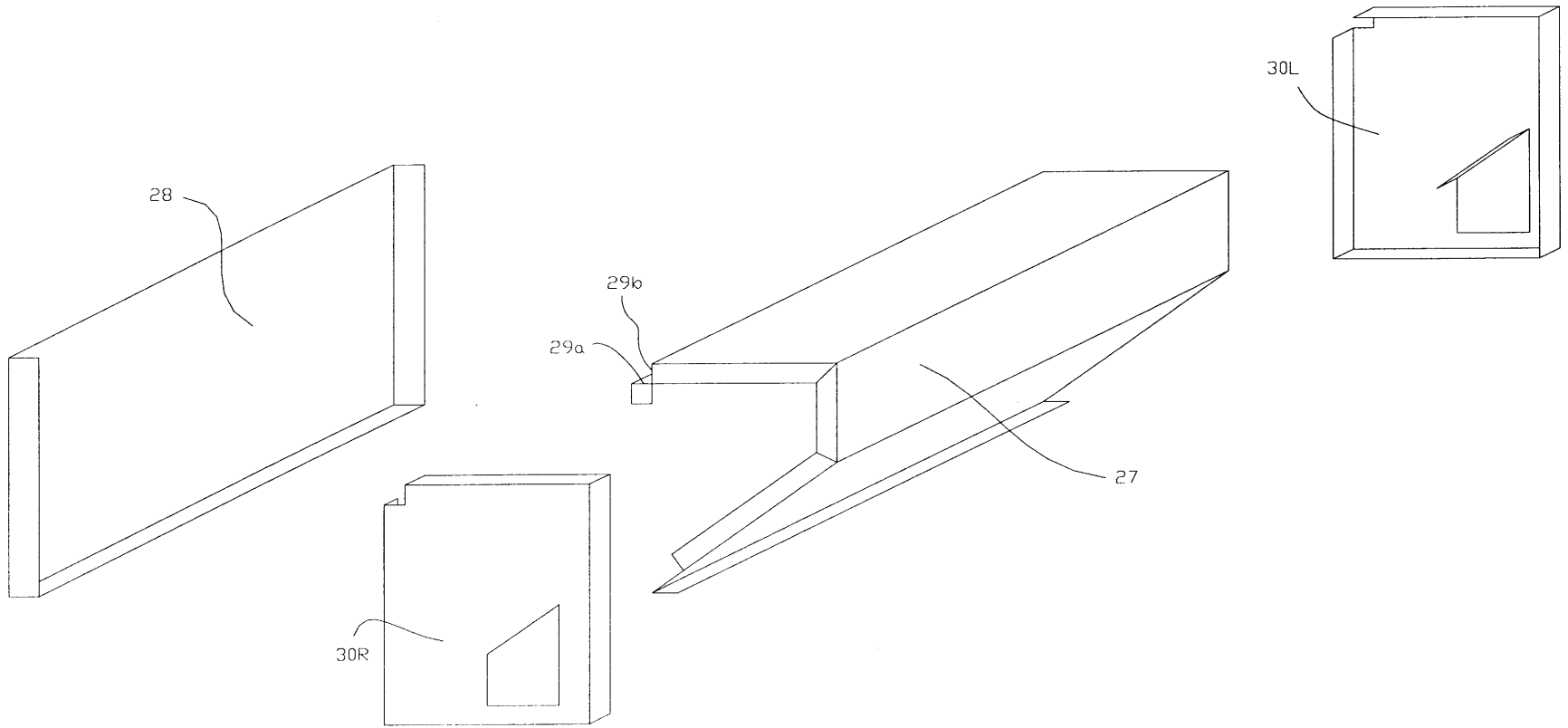

Fig. 5

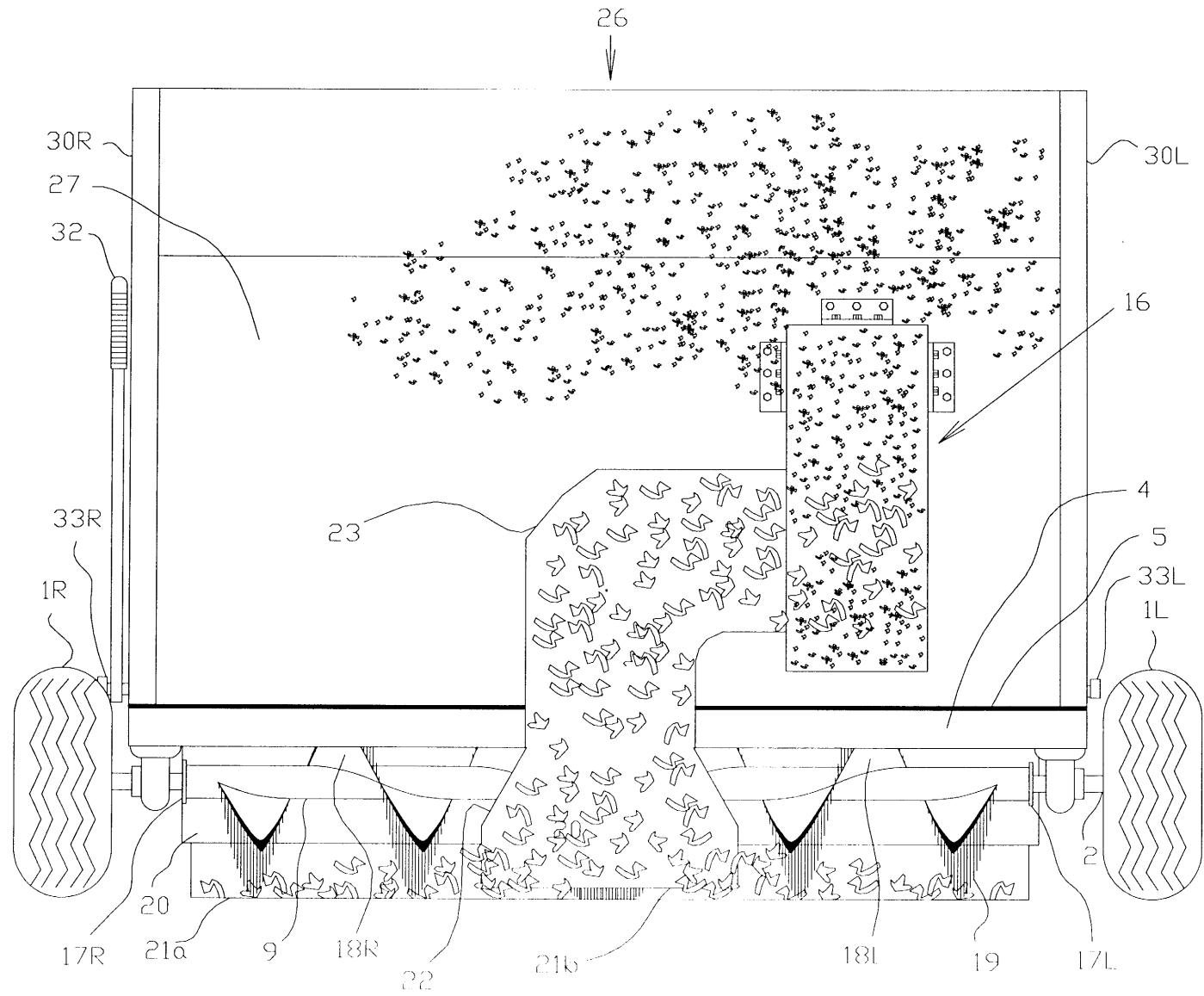

Fig. 6

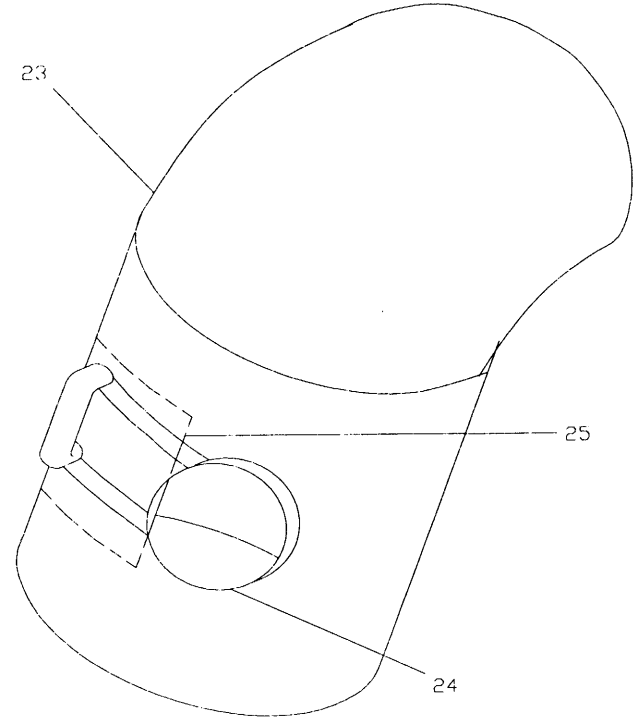
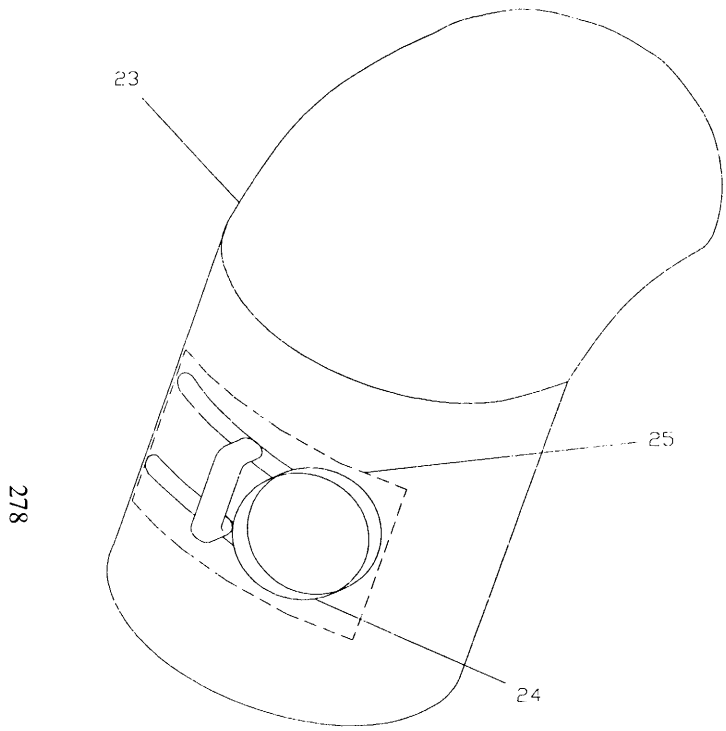
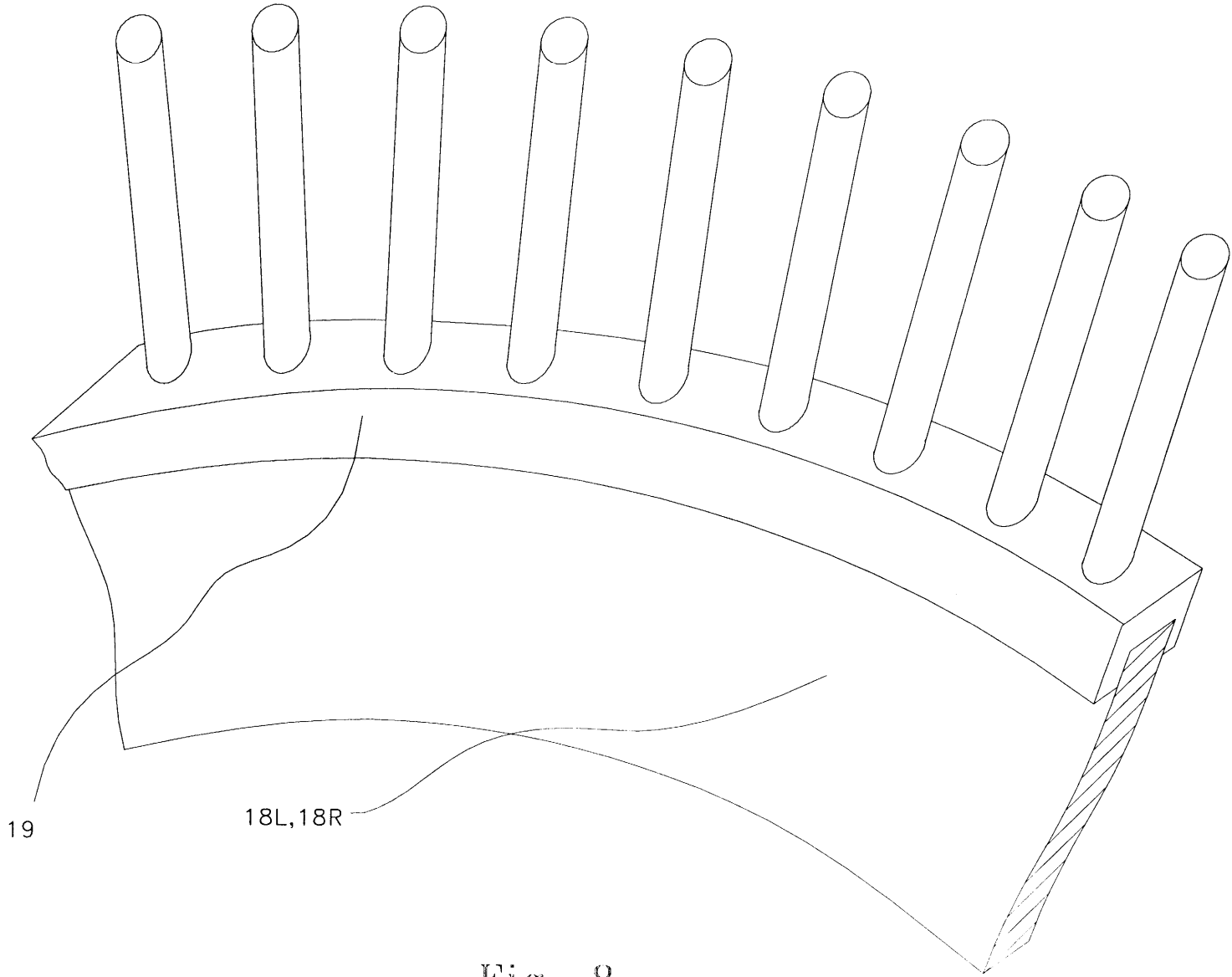

Fig. 7



19

18L,18R

Fig. 8

279

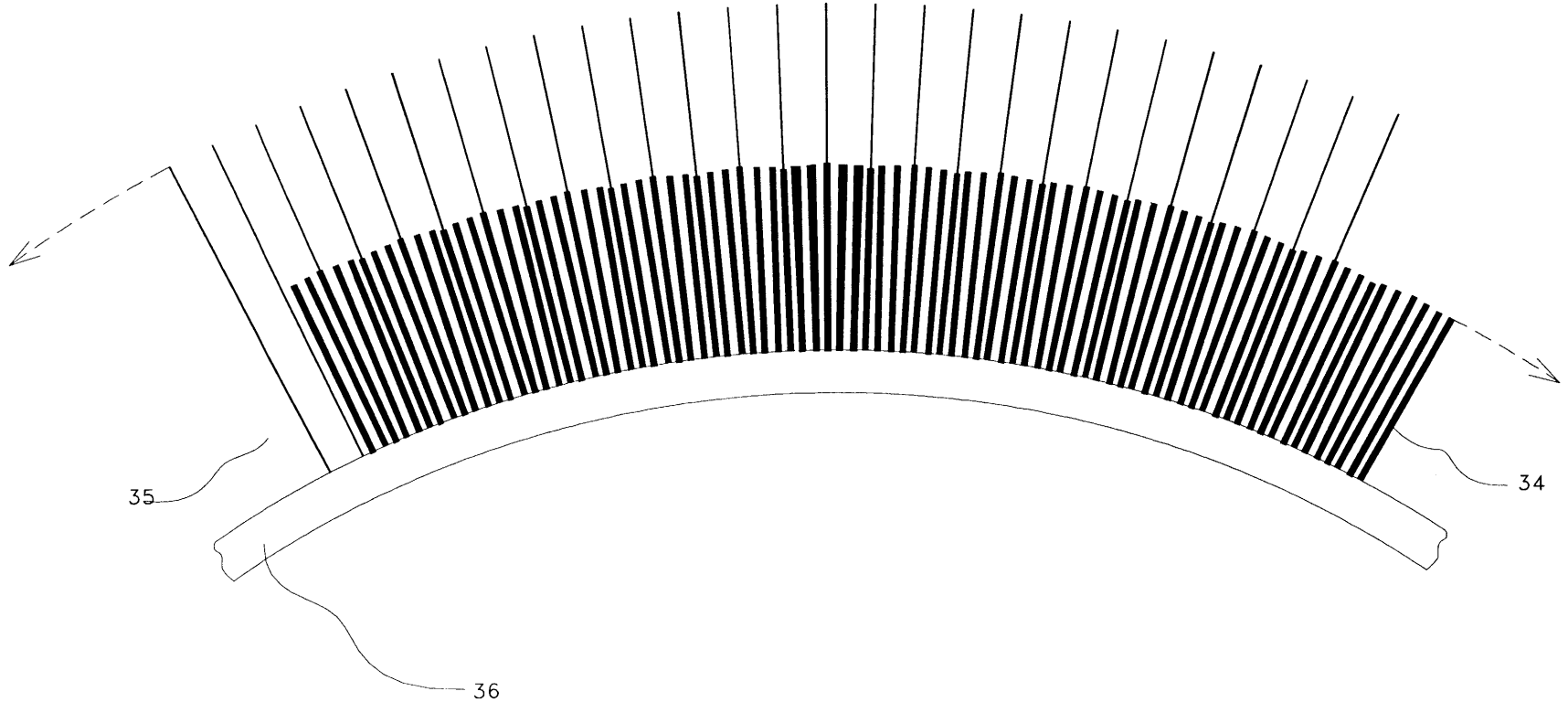

Fig. 9

Appendix C

Auger

The blue prints used to make the auger follow are presented in the remainder of this appendix.

Prototype Auger

- Material: 2 1/2" Schedule 160 Steel Pipe
- Flights: 1/16" Sheet Steel
- Double Flighting, Central Discharge
- 8" Pitch
- Ends Parallel to Within 3 Degrees

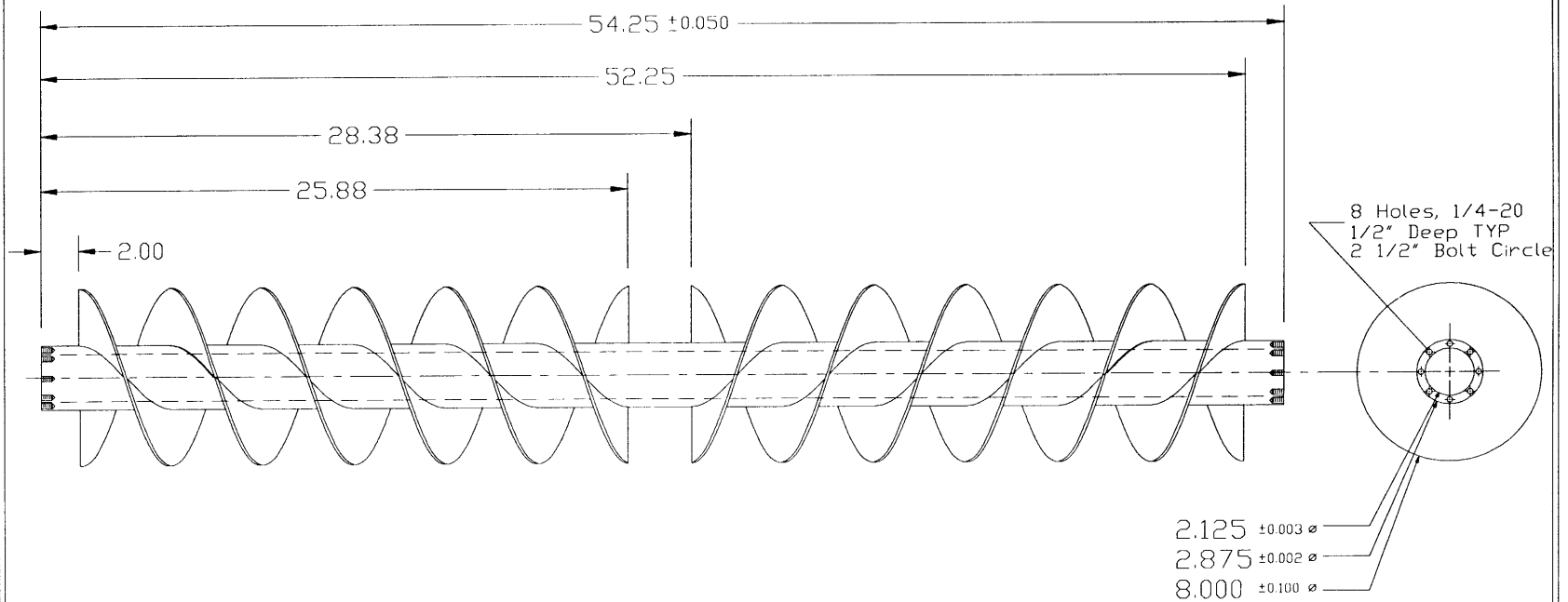

282

TITLE: Prototype Auger		M.E. Department of Mechanical Engineering		Phone: (617) 253-1953
NAME: Martin L. Culpepper		CHECKED BY: Martin L. Culpepper		
DATE: 02/17/96	SCALE: 1:8	REV #: D	CHECK DATE: 02/17/96	
TOLERANCES: ± 0.050" unless otherwise stated		FITES:		Alias: (617) 539-4986

Prototype Auger Insert

- Material: 1020 Steel

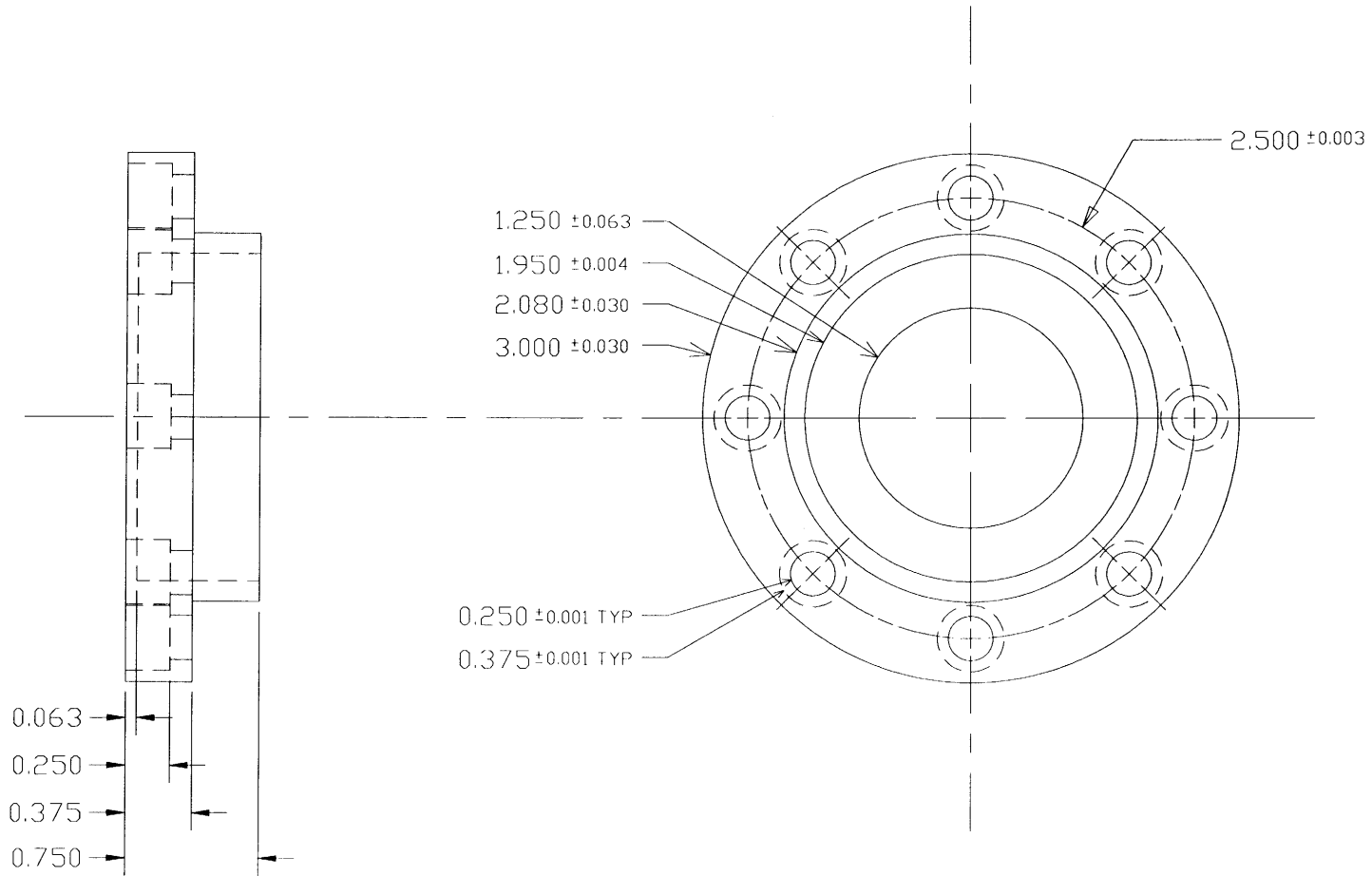

283

TITLE: Prototype Auger Insert
 NAME: Martin L. Culpepper
 DATE: 02/17/96 SCALE: 1:1 REV #: 1
 TOLERANCES: ±.001" unless otherwise stated

M.I.T. Department of Mechanical Engineering
 CHECKED BY: Martin L. Culpepper
 CHECK DATE: 02/17/96
 NOTES:

Phone: (617) 253-1953

Fax: (617) 539-4986

Trough Flap

- Material: 1/4" Neoprene, 60 Durometer
- Through Perforations Every 4 Inches
- 1/4" Stress Relief Holes at Slit Ends
- 1/8" Fastener Holes Every 4.0 "

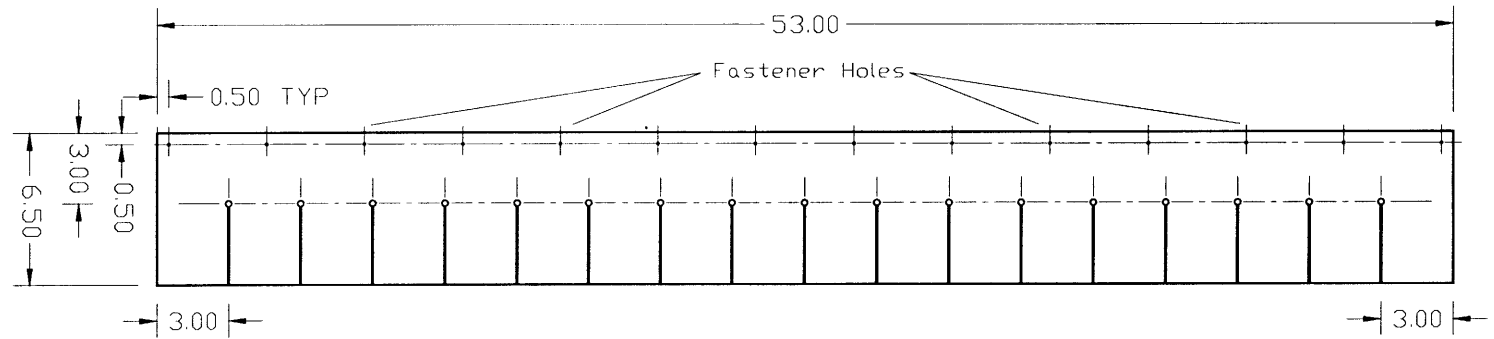

TITLE: Trough Flap			M.I.T. Department of Mechanical Engineering		Phone: (617) 253-1953
NAME: Martin L. Culpepper			CHECKED BY: Martin L. Culpepper		
DATE: 12/15/95	SCALE: 1:1	REV #: B	CHECK DATE: 12/15/95		Alias: (617) 539-4986
TOLERANCES: +/- 0.010" unless otherwise stated			NOTES		

Appendix D

Vacuum System

- estimation of leaf-air density
- prints for components of system

Estimation of Air/Debris Specific Weight

Leaves collected in a bag have a volume ratio of air to leaves of approximately 20:1. To calculate a density for a mixture of the two components, the following formula would be used.

$$\rho_{\text{mixture}} \sim [0.05(\rho_{\text{leaves}}) + 0.95(\rho_{\text{air}})]$$

Using air density at STP and value of leaf density of 9.3 lbm/ft^3 (volume of bag with no air measure and divided by weight), the estimate for mixture density is 0.53 lbm/ft^3 .

Air density had to be adjusted for power reading taken for the prototype as the temperature at the time of test was approximately 40°F as opposed to standard temperature (70°F). The following equation was used (treating air as an ideal gas) to calculate the new mixture density.

$$\rho_{\text{mixture}} \sim [0.05(\rho_{\text{leaves}}) + 0.95(\rho_{\text{air}}) * (273+70)/(273+40)]$$

Which yields 0.54 lbm/ft^3 , which is not significantly different.

Nozzle Side Flap

- Material: 1/4" Neoprene, 90 Durometer

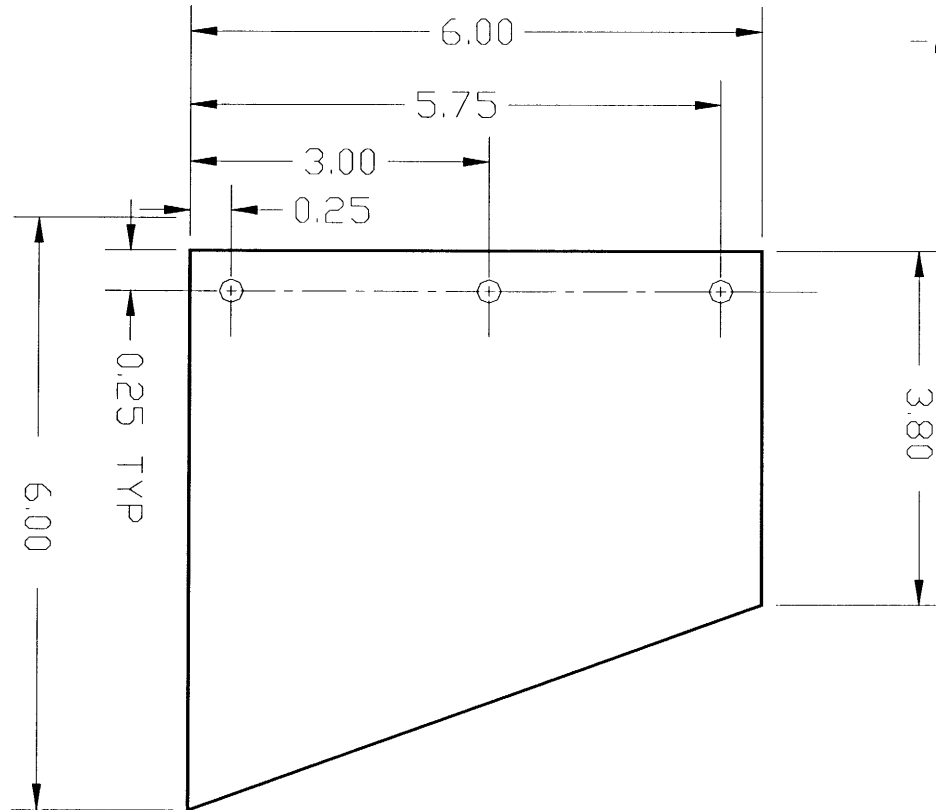

-All Hole Diameters 1/8"

287

TITLE: Nozzle Side Flap		M.E.T. Department of Mechanical Engineering		Phone: (617) 552-1953
NAME: Martin I. Culpepper		CHECKED BY: Martin I. Culpepper		
DATE: 12/11/95	SCALE: 1:2	RIV #: B		
TOLERANCES: +/- 0.050" unless otherwise stated		CHECK DATE: 12/11/95		Atlas: (617) 539-4986
		NOTES:		

Fan Support Bracket

- Material: 1/4" T6 Aluminum Angle

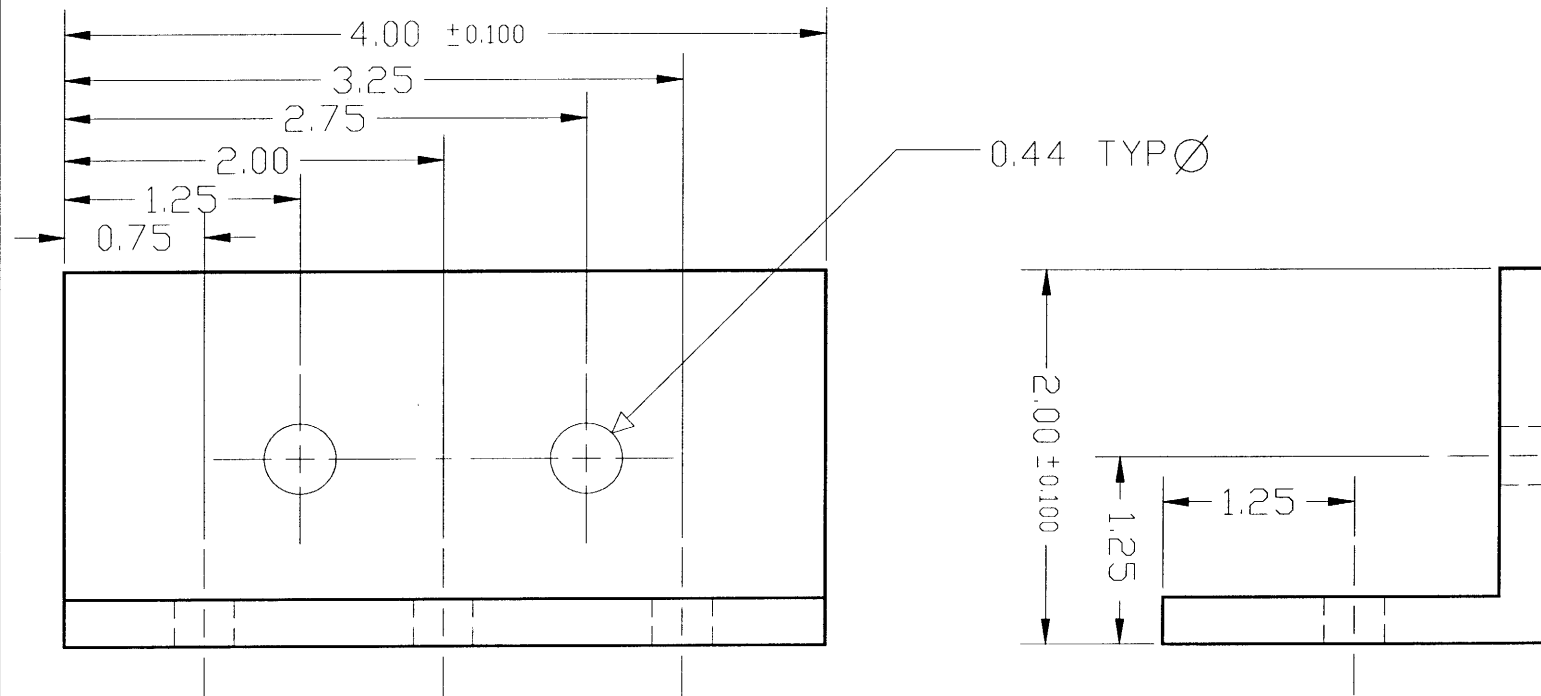

288

TITLE: Fan Support Bracket		
NAME: Martin L. Culpepper		
DATE: 12/10/95	SCALE: 1:1	REV #: A
TOLERANCES: +7- 0.005" unless otherwise stated		

M.I.T. Department of Mechanical Engineering
CHECKED BY: Martin L. Culpepper
CHECK DATE: 12/10/95
NOTES

Phone: (617) 253-1953

Alias: (617) 539-4986

Nozzle Front Flap

- Material: 1/4" Neoprene, 90 Durometer

-All Hole Diameters 1/8"

-Holes Equally Spaced at 2.00"

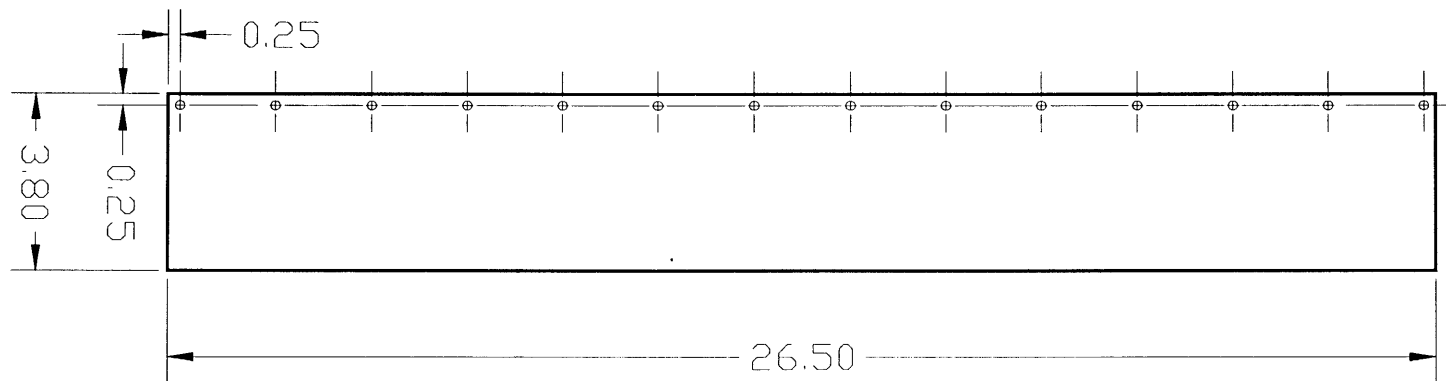

289

TITLE: Nozzle Front Flap		
NAME: Martin L. Culpepper		
DATE: 12/12/95	SCALE: 1:4	REV # A
TOLERANCES: +/- 0.010" unless otherwise stated		

M.I.T. Department of Mechanical Engineering
CHECKED BY: Martin L. Culpepper
CHECK DATE: 12/12/95
NOTES:

Phone: (617) 253-1953
Alias: (617) 539-4986

Inlet Nozzle

- Material: Galvanized Sheet Metal, Ductwork
- All Dimensions in Inches

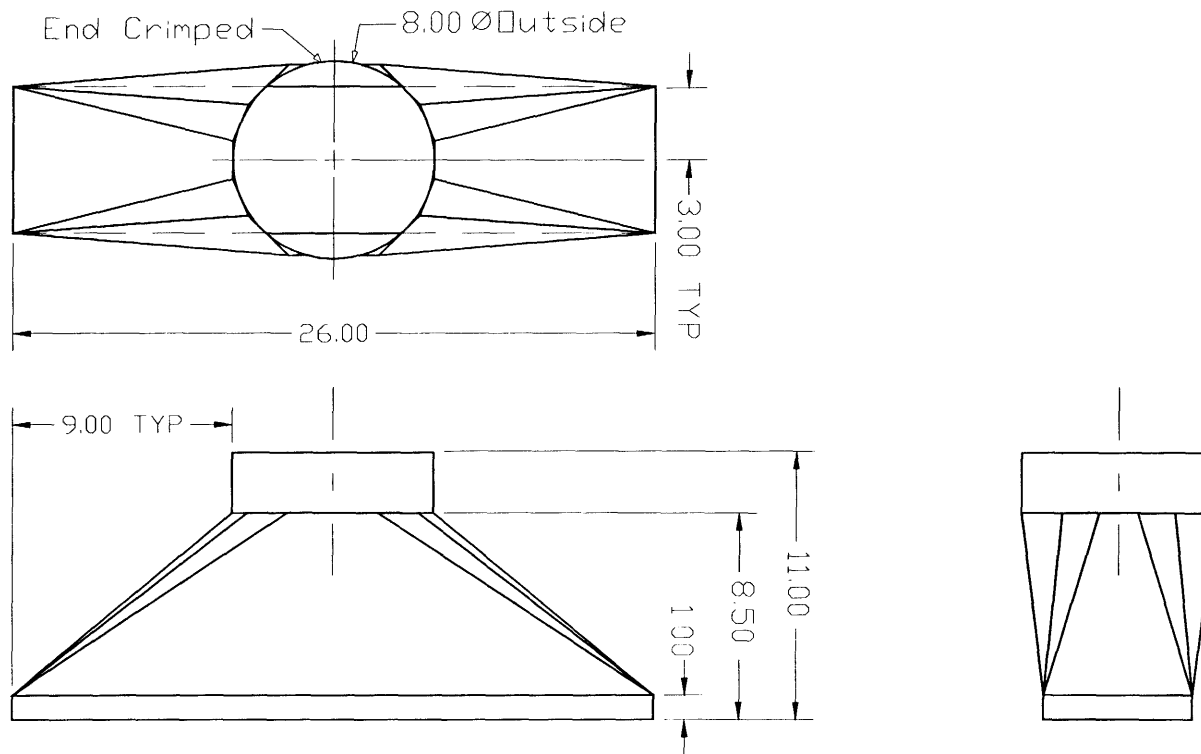

TITLE: Inlet Nozzle
 NAME: Martin L. Culpepper
 DATE: 11/28/95 SCALE: 1:8 REV #: 0
 TOLERANCES: $\pm 7/16$ " unless otherwise specified

M.I. Department of Mechanical Engineering
 CHECKED BY: Martin L. Culpepper
 CHECK DATE: 11/28/95
 NOTES:

Phone: (617) 253-1953
 Atlas: (617) 539-4986

Prototype Fan Mount Support

- Material: 2x2" Steel Tubing, 1/8" Thick
- All Dimensions in Inches

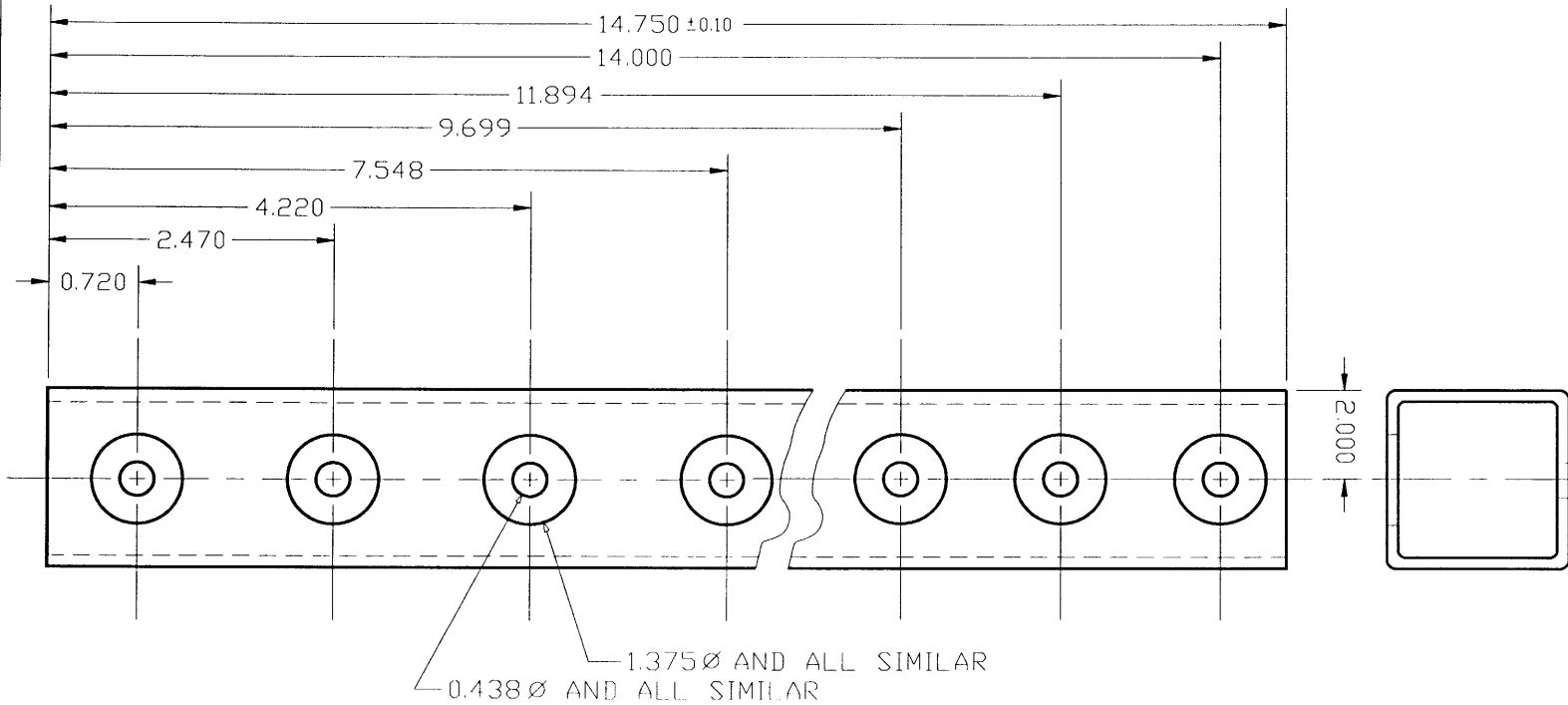

291

TITLE: Prototype Fan Mount Support			M.I. Department of Mechanical Engineering		Phone: (617) 253-1953
NAME: Martin L. Culpepper			CHECKED BY: Martin L. Culpepper		
DATE: 03/20/96	SCALE: 1:2	REV #: B	CHECK DATE: 03/20/96		Fax: (617) 539-4986
TOLERANCES: +/- 0.005" unless otherwise stated			NOTES:		

Prototype Fan Mount Shim

- Material: 1/8" HRS Plate
- Material: All Holes 7/16" Diam.

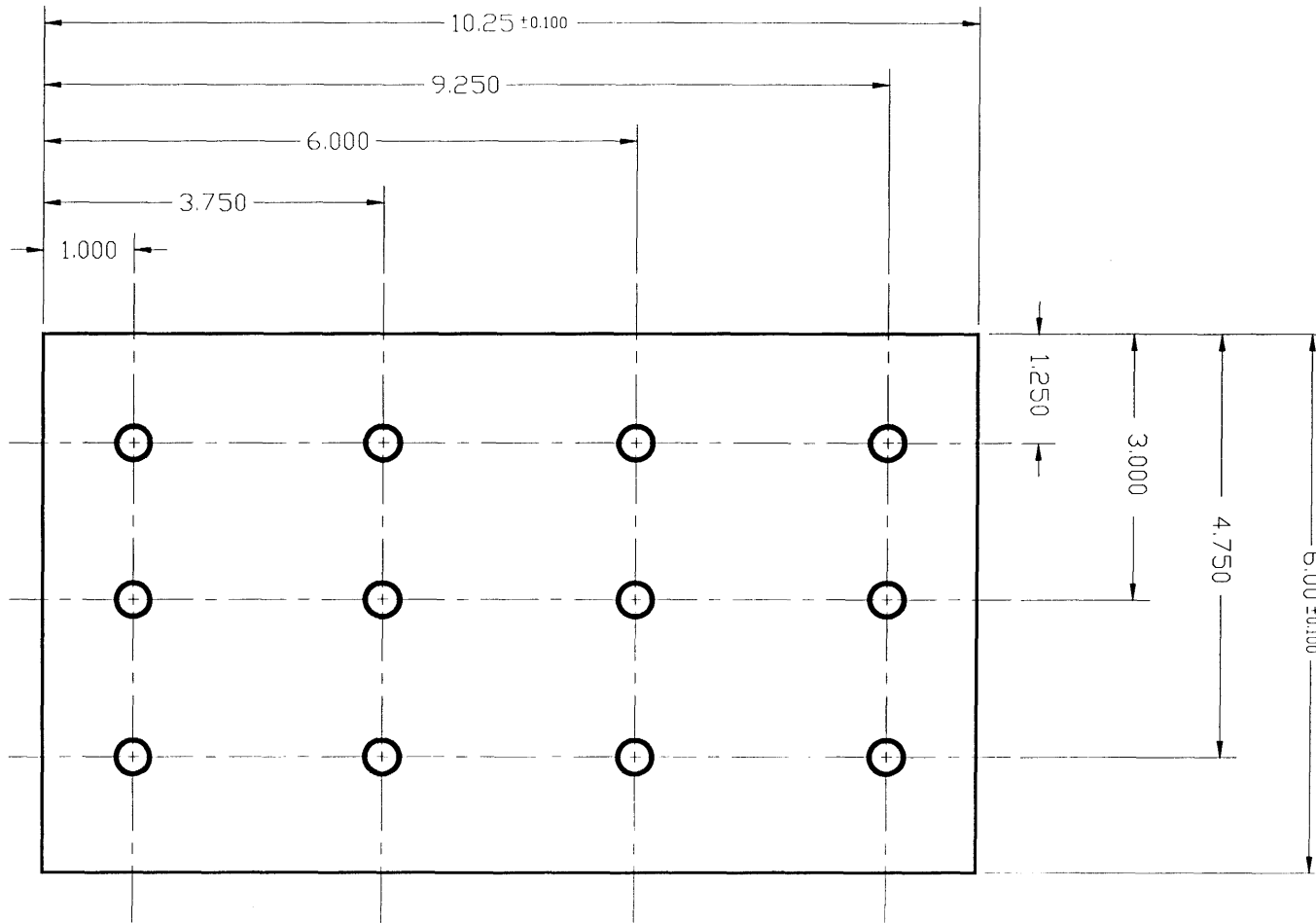

TITLE: Prototype Fan Mount Shim		
NAME: Martin L. Culpepper		
DATE: 03/21/96	SCALE: 1:2	REV. #: A
TOLERANCES: 1/16" 0.005" unless otherwise stated		

M.I.T. Department of Mechanical Engineering
CHECKED BY: Martin L. Culpepper
CHECK DATE: 03/21/96
NOTES:

Phone: (617) 253-1953
Alias: (617) 539-4986

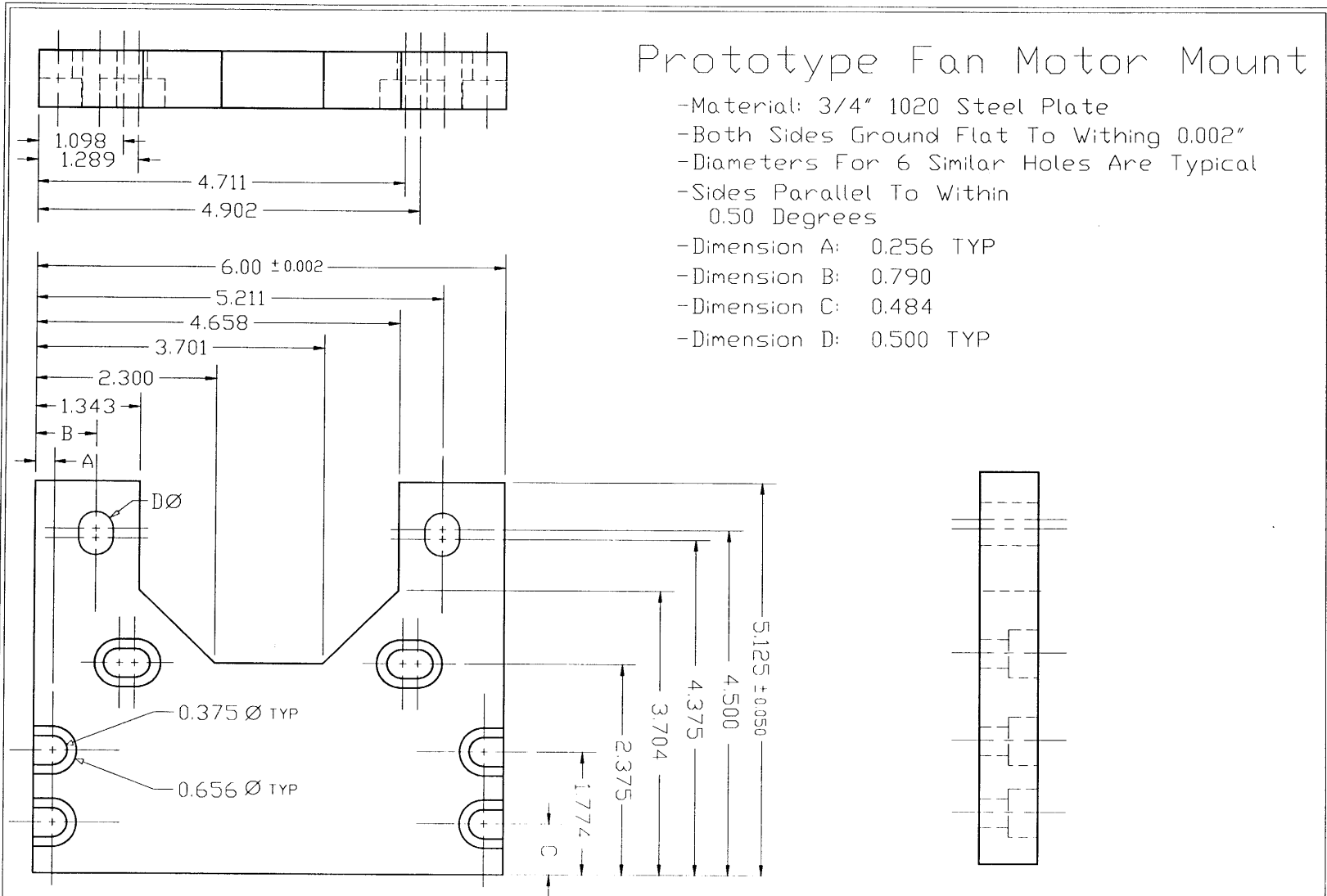

Prototype Fan Motor Mount

- Material: 3/4" 1020 Steel Plate
- Both Sides Ground Flat To Within 0.002"
- Diameters For 6 Similar Holes Are Typical
- Sides Parallel To Within 0.50 Degrees
- Dimension A: 0.256 TYP
- Dimension B: 0.790
- Dimension C: 0.484
- Dimension D: 0.500 TYP

TITLE: Prototype Fan Mount Mount			M.I.T. Department of Mechanical Engineering		Phone: (617) 253-1953
NAME: Martin L. Culpepper			CHECKED BY: Martin L. Culpepper		
DATE: 03/18/96	SCALE: 1:2	REV #: B	CHECK DATE: 03/18/96		
TOLERANCES: ± 0.003" unless otherwise stated			NOTES: All Dimensions in Inches		Atlas: (617) 539-4986

Prototype Fan Shaft Support

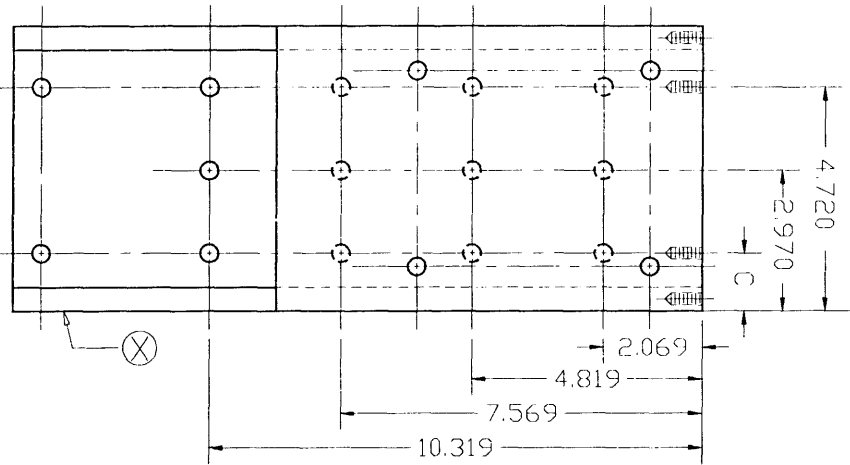

- Material: 6"x6" Steel Tubing, 1/2" Thick
- Surfaces W,X,Y,Z, Flat To Within 0.030"
- Surface V, Perpendicular To Surface W To Within 0.50 Degrees
- Surface W, Perpendicular To Surface Y To Within 0.50 Degrees
- Surface W&Y, Perpendicular To Surface X To Within 0.50 Degrees
- Surface W, Parallel to Surface Z to Within 0.003"
- All Hole Diameters: 7/16"
- Dimension A: 0.941
- Dimension B: 1.192
- Dimension C: 1.220

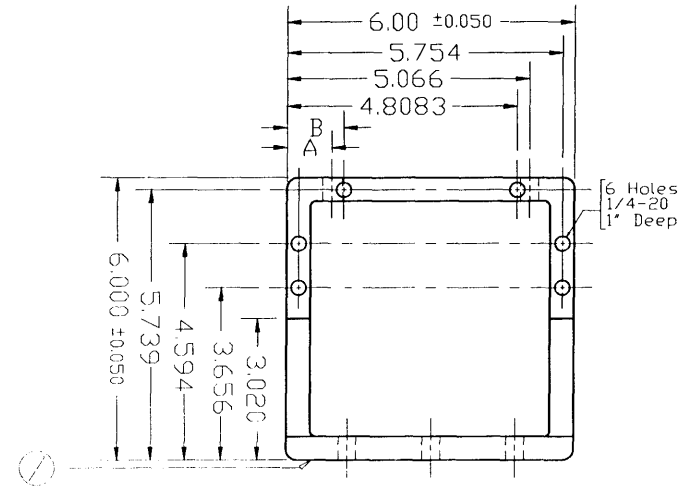
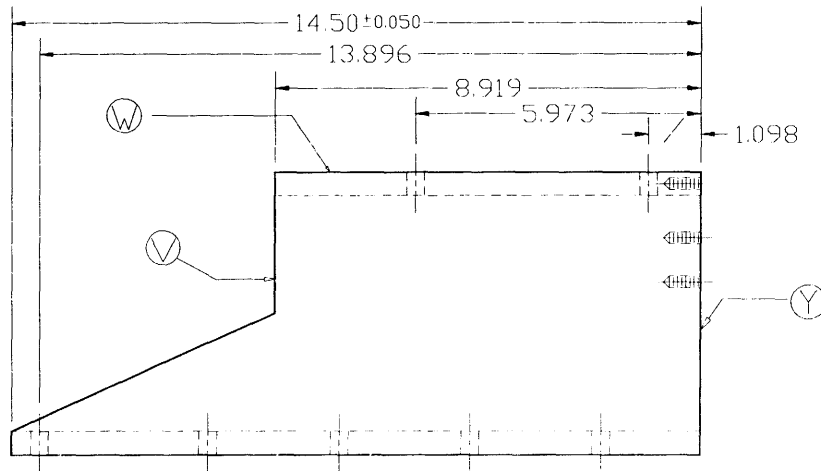

TITLE: Prototype Fan Shaft Support
 NAME: Martin L. Culpepper
 DATE: 03/12/96 SCALE: 1:1 REV: # A
 TOLERANCES: +/- 0.003" unless otherwise stated

M.E. Department of Mechanical Engineering
 CHECKED BY: Martin L. Culpepper
 DATE: 03/12/96
 NOTE: ALL DIMENSIONS IN INCHES

Phone: (617) 253-1953

Altas: (617) 539-4986

Prototype Fan Shaft

- Material: HT 4140 Steel, 125 ksi Min Tensile Strength
- End Relief Radius on Key Ways: 0.125"
- Key Way Seat Radii: 0.050"
- Surface Finish: 0.30 μ

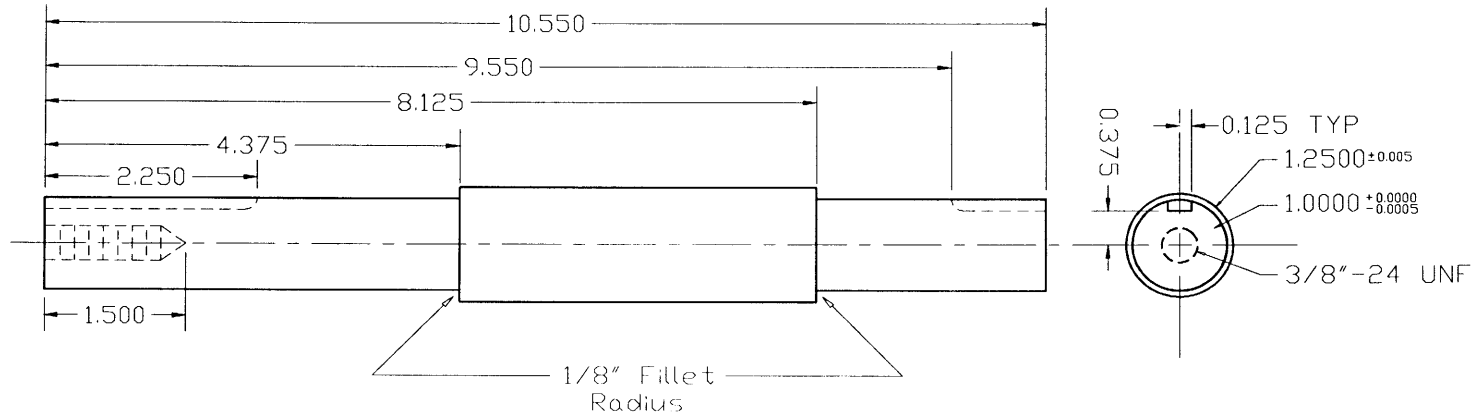

295

TITLE: Prototype Fan Shaft		
NAME: Martin L. Culpepper		
DATE: 03/16/96	SCALE: 1:2	REV #: A
TOLERANCES: +/- 0.003" unless otherwise stated		

M.E. Department of Mechanical Engineering	Phone: (617) 253-1953
CHECKED BY: Martin L. Culpepper	
CHECK DATE: 03/16/96	
NOTE: ALL Dimensions in Inches	Atlas: (617) 539-4986

Appendix E

Power and Drive Train

- prints of drive train components

Prototype Rear Pump Mount Bracket

- Material: 1/4" Angle, T6 Aluminum

-All Hole Diameters 7/16"

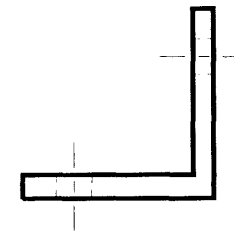
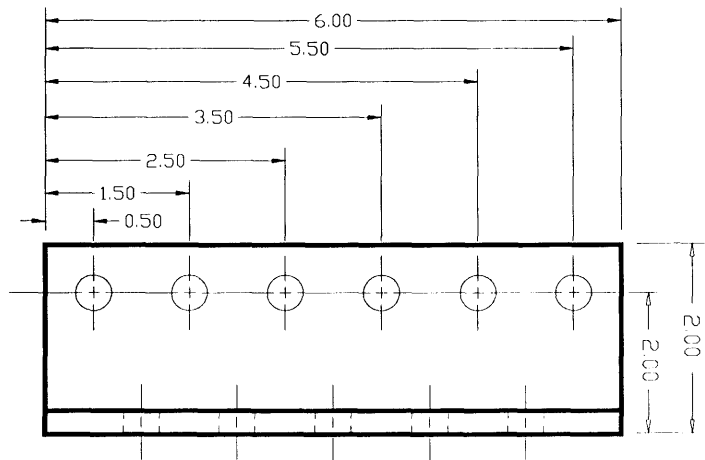
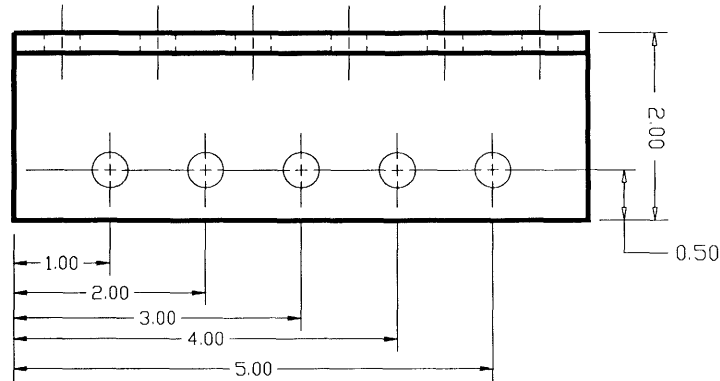

TITLE: Prototype Rear Pump Mount Bracket			M.E. Department of Mechanical Engineering		Phone: (617) 253-1953
NAME: Martin L. Culpepper			CHECKED BY: Martin L. Culpepper		
DATE: 01/17/96	SCALE: 1:2	REV #: D	CHECK DATE: 01/17/96		
TOLERANCES: +/- 0.010" unless otherwise stated			NOTES:		Also: (617) 539-4986

Prototype Front Pump Mount Bracket

- Material: 1/4" Angle, T6 Aluminum

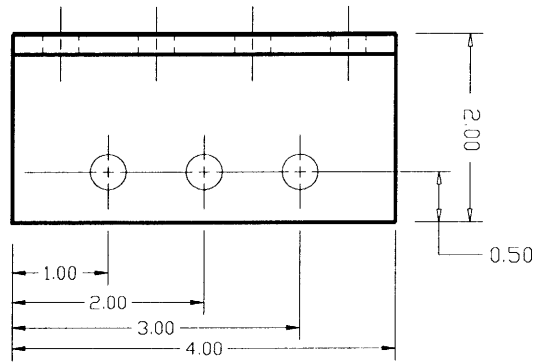

-All Diameters 7/16"

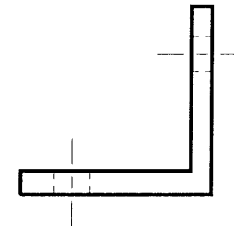
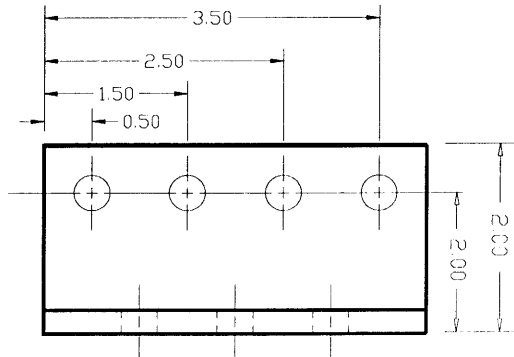

TITLE: Prototype Front Pump Mount Bracket
 NAME: Martin L. Culpepper
 DATE: 01/25/96 SCALE: 1:2 REV #: 1
 TOLERANCES: +/- 0.010" unless otherwise stated

M.I.T. Department of Mechanical Engineering
 CHECKED BY: Martin L. Culpepper
 CHECK DATE: 01/25/96
 NOTES:

Phone: (617) 253-1953

Alias: (617) 539-4986

Prototype Engine and Hydraulic Pump Support

1020 Steel, 0.750" thick, ground flat both sides to within 0.002" across plate

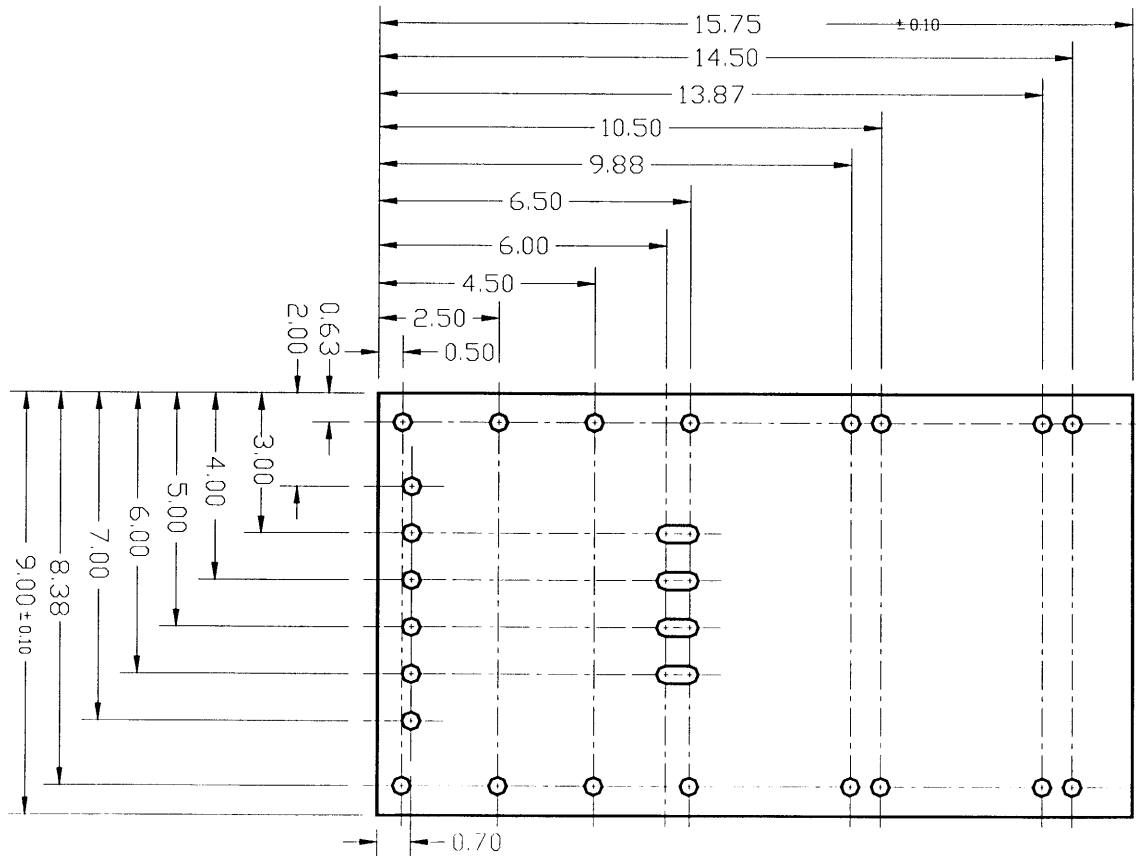

-All Diameters 7/16"
Unless Otherwise Specified

TITLE: Prototype Engine and Hydraulic Pump Support		M.E. Department of Mechanical Engineering		Phone: (617) 253-1953
NAME: Martin L. Culpepper		CHECKED BY: Martin L. Culpepper		
DATE: 03/08/96	SCALE: 1:4	REV #: A	CHECK DATE: 03/08/96	Alias: (617) 539-4986
TOLERANCES: +/- 0.005" unless otherwise stated			NOTES:	

Prototype Pump Mount

- Material: 7x5 Steel Tubing, 3/8" Thick

-All Hole Diameter 7/16 Unless
 Otherwise Specified

-Surface A and B Perpendicular
 To Within 0.75 Degrees

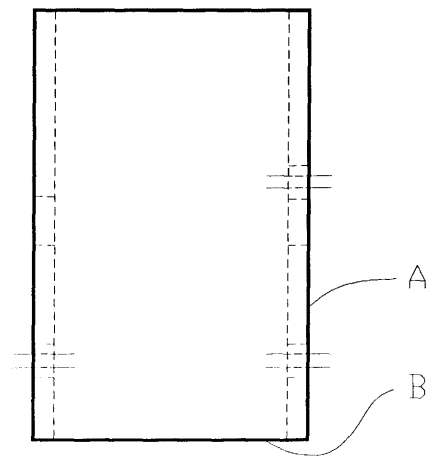
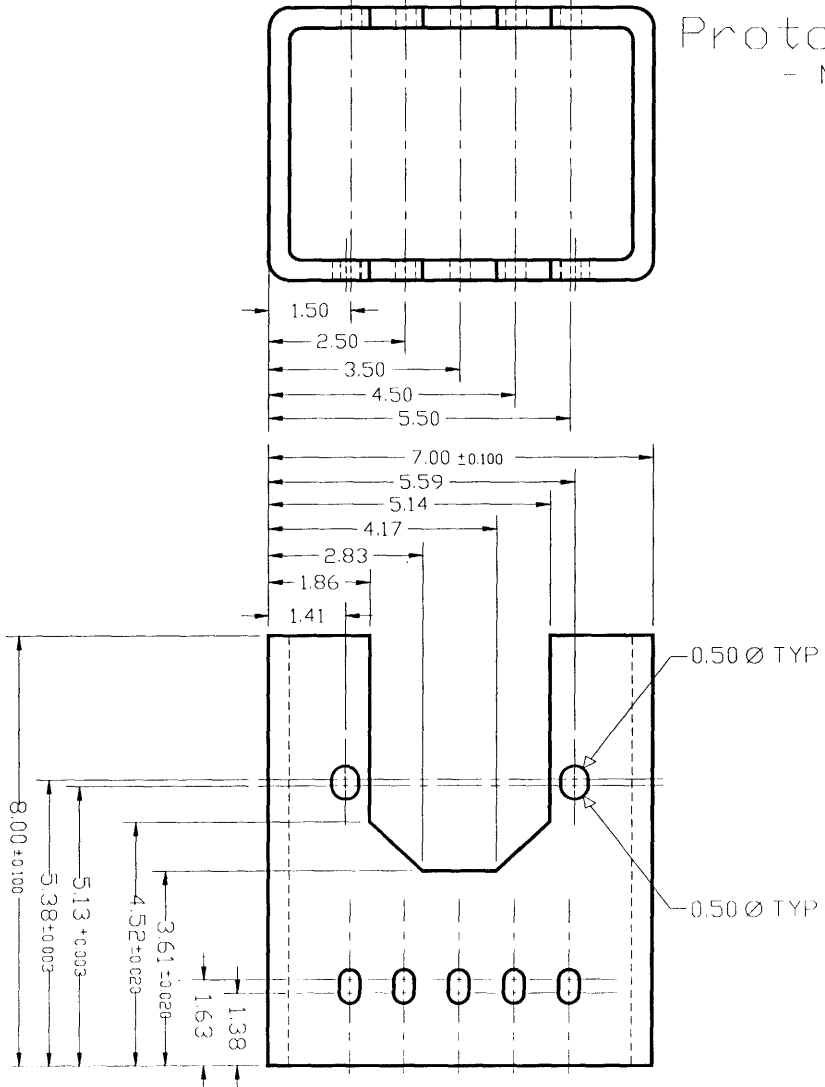

300

TITLE: Prototype Pump Mount			M.I. Department of Mechanical Engineering		Phone: (617) 253-1933
NAME: Martin L. Culpepper			CHECKED BY: Martin L. Culpepper		
DATE: 02/17/96	SCALE: 1:1	REV: # 0	CHECK DATE: 02/17/96		
TOLERANCES: +/- 0.003" unless otherwise stated			NOTES:		Atlas: (617) 539-4986

Prototype Auger Motor Mount

- Material: 1/4" Angle, T6 Aluminum

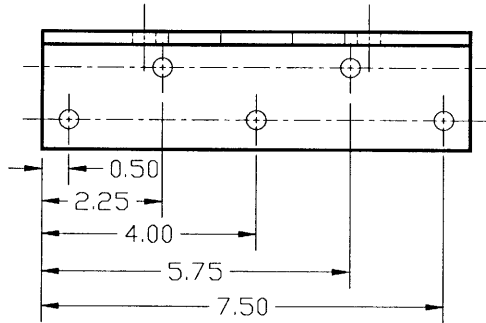

-All Hole Diameters 7/16"
Unless Otherwise Specified

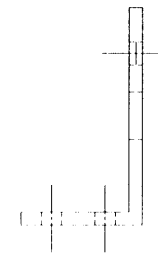
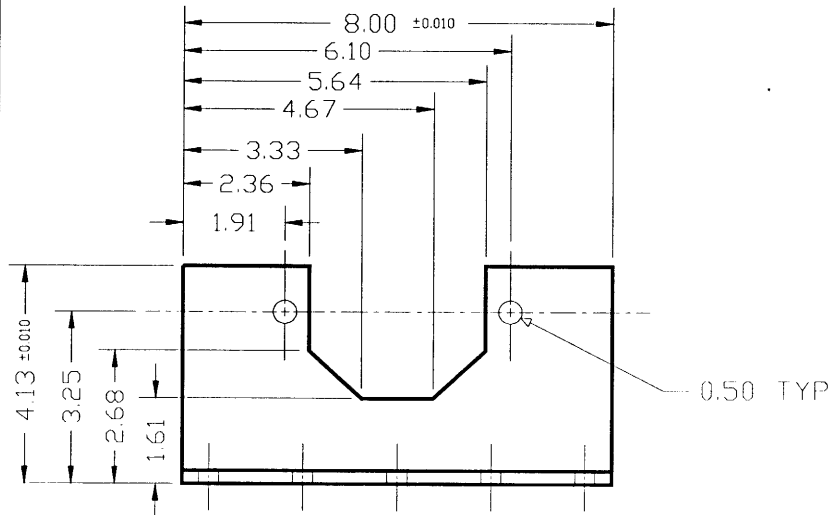

TITLE: Prototype Auger Motor Mount
 NAME: Martin L. Culpepper
 DATE: 12/11/95 SCALE: 1:4 REV # B
 TOLERANCES: +/- 0.005" unless otherwise stated

M.I. Department of Mechanical Engineering
 CHECKED BY: Martin L. Culpepper
 CHECK DATE: 12/11/95
 NOTES:

Phone: (617) 253-1953
 Alias: (617) 539-4986

Appendix F

Axle

- prints of components related to axle
- estimate of axle fatigue factor of safety
- final estimate of fatigue factor of safety
- deflection analysis for auger bearings

Prototype Axle

- Material: 4140 HT Steel, 125 ksi min

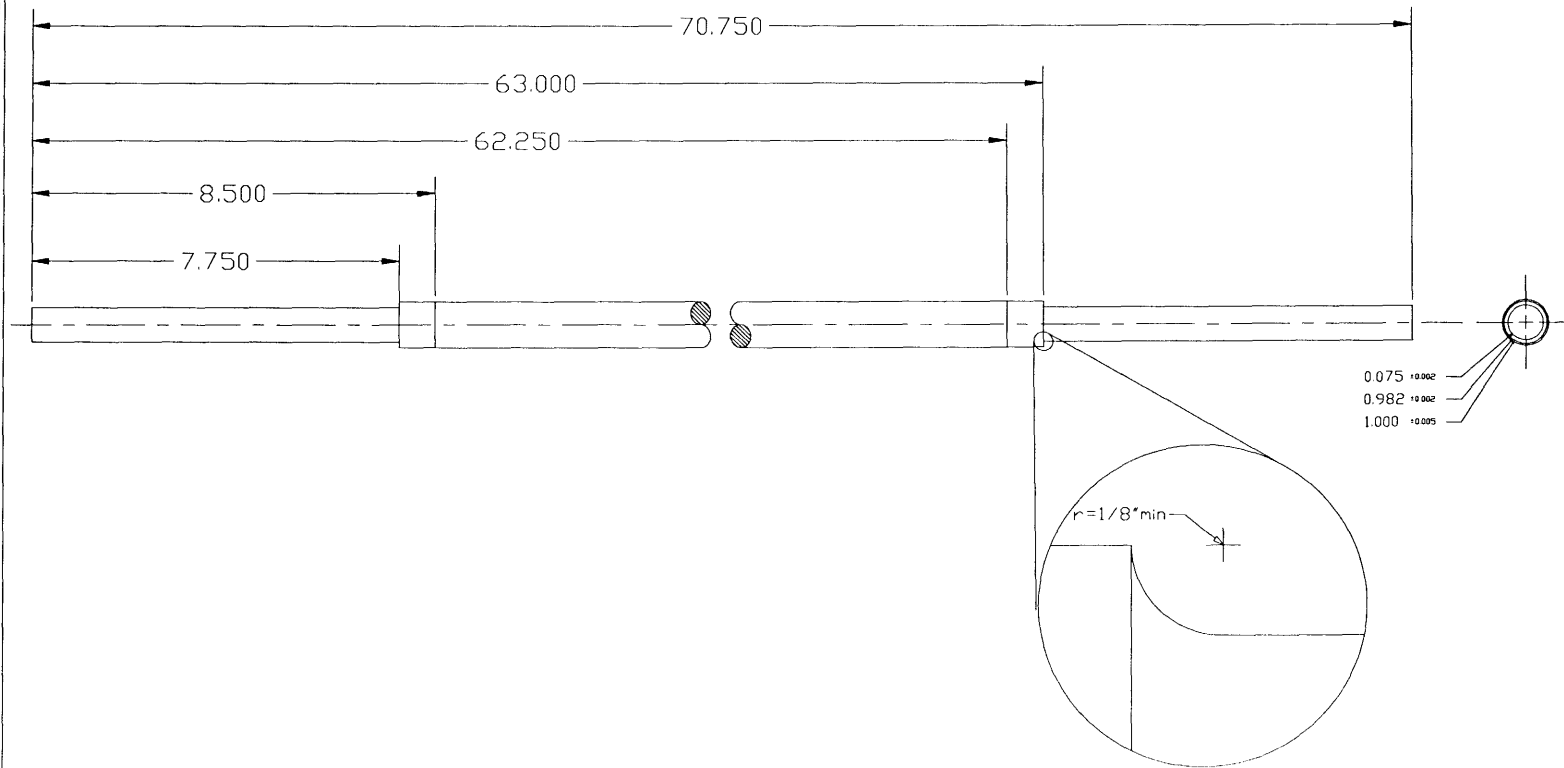

303

TITLE: Prototype Axle			M.I.T. Department of Mechanical Engineering		Phone: (617) 253-1953
NAME: Martin L. Culpepper			CHECKED BY: Martin L. Culpepper		
DATE: 11/01/95	SCALE: 1:16	REV #: C	CHECK DATE: 11/01/95		Alias: (617) 539-4986
TOLERANCES: $\pm 0.020''$ unless otherwise stated			NOTE: Axle is symmetric		

Prototype Axle

- Material: 4140 HT Steel, 125 ksi min

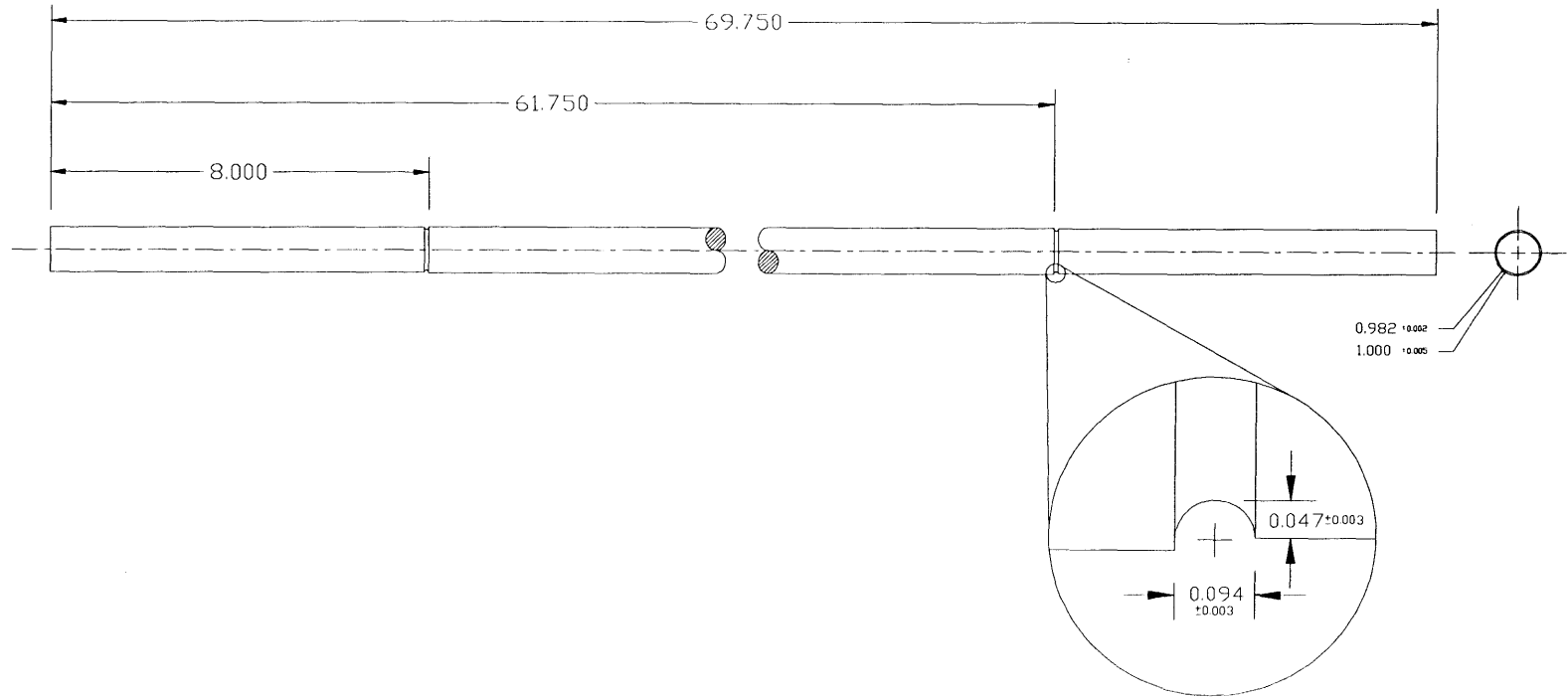

TITLE: Prototype Axle		M.E. Department of Mechanical Engineering		Phone: (617) 253-1953
NAME: Martin L. Culpepper		CHECKED BY: Martin L. Culpepper		
DATE: 02/13/96	SCALE: 1:16	REV: # 1	CHECK DATE: 02/13/96	Alias: (617) 539-4986
TOLERANCES: ± 0.020 " unless otherwise stated		NOTES:		

Discussion of prototype axle factor of safety

Note: Steel Strength obtained from: Pat McDonald of Matt McDonalds, Boston, MA.

In the original design for the prototype axle, a snow blower auger was to rotate about the axle. The auger bearings required an axle 0.75 inches in diameter. The suitability of a 4140 steel rod with $S_{ut} = 125$ kpsi was evaluated by calculating a factor of safety. At the time, emphasis was placed on ordering the prototype parts as quickly as possible. As such, a quick estimate was needed and the effects of the Marin factors (fatigue factors) were not included.

Original Weight and Stress Estimates

Component	Fy lbf
Hopper	-155
Frame	100
Leaves	-180
Turbine	-10
Fan Housing	-15
Hydraulic Tank	-30
Hydraulic Fluid	-100
Hydraulic Hoses	-10
Motor Base Plate	-15
Auger Motor	-18
Fan Motor	-12
Nozzle	-5
Auger Shaft	-75
Auger Blades	-20
Engine	-100
Fan Shaft	-8
Hitch	-10
Trough	-15
	$\Sigma =$ -677.9

Solution	Rb=	-339	lbf	
	Ra=	-339	lbf	
	Check: Σ =	-678	lbf	Ok

This estimate assumes the full weight of the prototype rests on the axle, none of the weight is supported by the tractor hitch. This will yield an overestimate.

$$S_e = 0.5 S_{ut} = 63.0 \text{ kpsi}$$

$$\sigma_a = 55.2 \text{ kpsi} \quad \text{at snap ring groove, } x = 60.7 \text{ inches}$$

Estimate includes stress concentration factor of 2.5 and is multiplied by a factor of 2.25 to account for dynamic loading. Estimate does not include Marin (fatigue) factors

$$\eta_f = \frac{S_e}{\sigma_a} = 1.14 \quad (\text{infinite life}) \qquad \eta_s = \frac{S_{ut}}{\sigma_a} = 2.54 \quad (\text{static})$$

The design seemed adequate, so parts of the prototype which depended on the diameter of the axle (pillow blocks and wheels) were ordered for the 0.75 inch diameter axle. Later a more rigorous analysis showed that a 0.75 inch axle would not be strong enough. The axle diameter was stepped up to 1.00 inches to provide additional strength.

Calculations for Prototype Axle Reliability (new design)

Estimation for weight supported by axle

The following values and diagrams were used to calculate stresses in the prototype axle. free body diagrams of the axle and various components are provided where needed for interpretation of force balances.

Specific Weights (lb/in³)

γ steel	0.283	γ leaves	0.005
γ wood	0.024	γ aluminum	0.098
γ rubber	0.043		

All Moment Arms of Reaction "x" With Respect to Point A, or O

check diagram to determine point

r_x	i	j	k
r_{Rb}	0	0	-63.6
r_{Rc}	0.0	0	-31.8

(see skematic below)

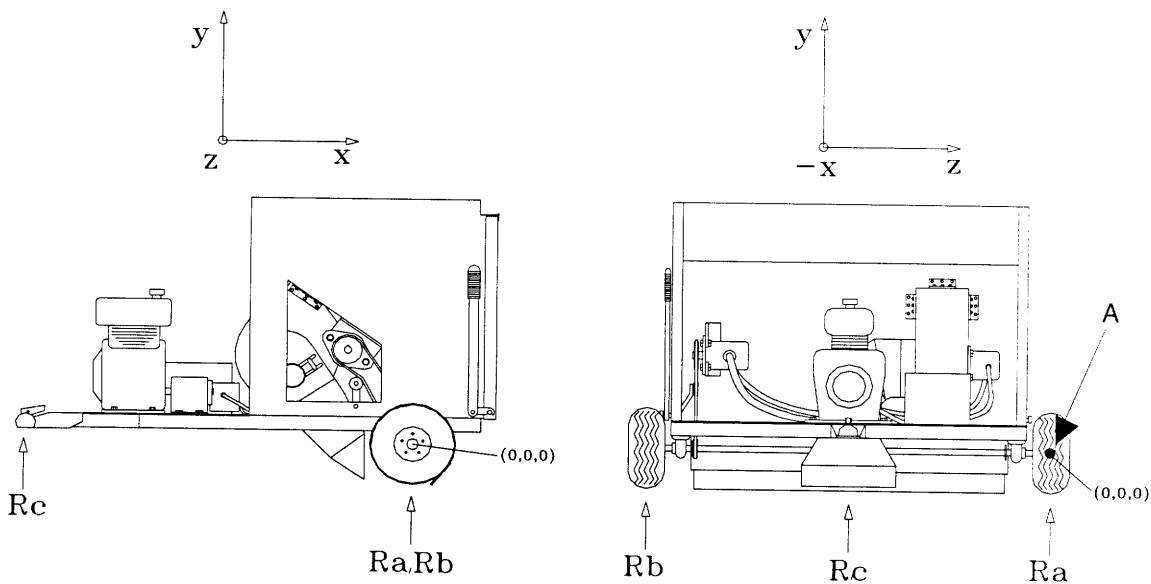

Component Weights and Reaction Forces

(reaction forces and moments are figured individually, then added)

Component	Fy lbf	Rx inches	Rz inches	Mx lb-in	Mz lb-in
Hopper	-248.9	-6.2	-31.8	7915	1545
Frame	-119.9	-30.0	-31.8	3813	3597
Leaves	-185.3	-4.2	-31.8	5892	778
Turbine	-23.6	-16.9	-20.6	487	398
Fan Housing	-30.2	-16.9	-20.6	623	510
Hydraulic Tank	-47.3	-41.0	-24.2	1144	1938
Hydraulic Fluid	-101.6	-41.0	-24.2	2459	4165
Hydraulic Manifolds	-12.2	-29.5	-50	609	359
Hydraulic Hoses	-11.4	-29.5	-31.8	362	336
6x6 Steel Tube	-40.4	-16.9	-10	404	682
2x2 Steel Tubes	-8.2	-22.6	-10.9	90	186
6x6 Steel Plate	-6.4	-16.9	-8	51	107
7x5 Steel Tube	-15.5	-36.3	-44.8	695	563
Motor Base Plate	-30.1	-40.0	-44.8	1348	1203
Auger Motor	-17.8	-10.2	-56	996	181
Fan Motor	-12.4	-16.9	-5.3	66	210
Nozzle	-5.0	-16.9	-31.8	159	84
Auger Shaft	-74.9	0.0	-31.8	2382	0
Auger Blades	-21.3	0.0	-31.8	679	0
Engine	-110.0	-44.8	-44.8	4928	4928
Fan Shaft	-7.9	-16.9	-10	79	132
Hitch	-10.0	-64.0	-31.8	318	640
Trough	-28.0	0	-31.8	891	0
Rubber Fingers	-2.6	0	-31.8	82	0
Miscellaneous	-50.0	-10.0	-31.8	1590	500
$\Sigma =$	1220.9	lbf			

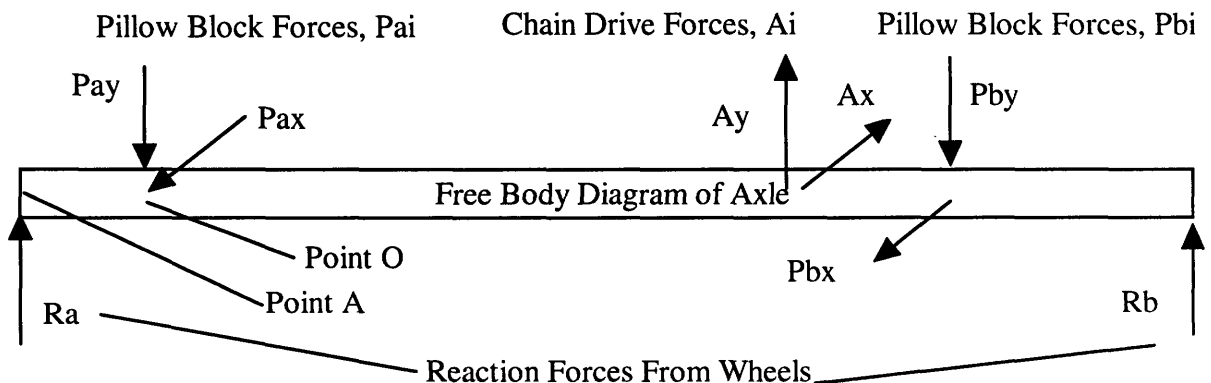

Solution:

From Moment Sum

Rb=	397	lbf
Rc=	352	lbf
Ra=	<u>471</u>	lbf

Check: $\Sigma =$ 1221 lbf Ok**Chain Drive Forces Reaction Forces**

Auger Power	1.2	hp	
Auger Speed	150	rpm	
Auger Torque	504	in-lbf	
Auger Sprocket Radius	4.5	inches	
Auger Force	112	lbf	-assume one side of chain slack
ϕ	54.0	deg	-angle chain makes with horizontal
Ay	91	lbf	-decomposed auger forces from
Ax	66	lbf	chain drive

Sum Moments about O

rA	43.2	inches
rRb'	56.7	inches
PAx	16	lbf
PBx	50	lbf

Pillow Block Forces Reaction Forces**Sum Moments about T**

PAy	1063	lbf
PBy	1149	lbf
Rb, Ra	1061	lbf
ra'	4.5	inches
rPA	5.6	inches
rA'	60.7	inches
rPB	62.4	inches
Rb'	63.5	inches
Rb''	68.0	inches

Note: X 2.5 to take in effect impact loading
Ra~Rb assumed larger value of two taken

Axle Moment Data

	x inches	My lb-in	Mx lb-in	Mtot lb-in
A	0	0	0	0
ra'	4.5	0	2386	2386
rPA	5.6	0	3553	3553
rA'	60.7	-866	3405	3514
rPB	62.4	785	3553	3639
rb'	63.5	0	2386	2386
rb''	68.0	0	0	0

Stress Concentration Calculations (For Snap Ring Groove)

r	0.047	r/d	0.051
d	0.925	D/d	1.081
D	1.000	q	0.842
Kt	2.200	Kf	2.010

$$\sigma_a = 45.2 \text{ ksi}$$

$$K_f * \sigma_a = 90.9 \text{ ksi}$$

The weight of the production model will decrease because:

- 1 the machine (hopper) will not be as wide
- 2 the hopper will be made from aluminum sheet
- 3 a smaller, lighter engine will be used
- 4 less steel will be needed for mounting/reference surfaces
- 5 the size and weight of the auger will decrease because the width of the machine will decrease

Fatigue Factor of Safety Analysis

The following method of calculating reliability was taken from, Mechanical Engineering Design, by Shigley and Mischke, 5th edition. All page numbers in the analysis refer to the above mentioned text.

Ultimate Strength, S_{ut}

Given 4140 steel heat treated to Rockwell C 28-32 and $S_{ut} = 125$ kpsi minimum.

Note: Values quoted from Matt McDonald Steel Company

$S_{ut} = 125$ kpsi see p. 198

Test specimen endurance limit, S_e' $S_e' = 0.504 S_{ut}$ see p. 281

$S_e' = 63.0$ kpsi

Marin factor for surface finish, K_a

$K_a = a' S_{ut}^{b'}$ see p. 291 for machined surfaces:

$K_a = 0.751$ $a' = 2.700$ and $b' = -0.265$

Marin factor for size, K_b $K_b = 0.872 d^{-0.1133}$ see p. 283

$K_b = 0.880$

Marin factor for load, K_c

$K_c = 1.000$ see p.292

Endurance limit, Se

$$Se = 41.7 \text{ kpsi}$$

$$Se = Ka Kb Kc Se' \text{ see p. 291}$$

Alternating shoulder stress, sa

$$\sigma_a = Mc/I = 45.2 \text{ kpsi}$$

$$M = 3513 \text{ lb-in}$$

$$c = 0.463$$

The alternating stress must be multiplied by K_f , the stress concentration factor, to adjust for the stress concentration at the snap ring groove.

$$\sigma_a K_f = 90.9 \text{ kpsi}$$

Axle Reliability

$$\eta\phi = \frac{Se}{\sigma_a K_f} = 0.46$$

Using the life equation for an S-N diagram the life of the axle can be estimated.

see p. 280

$$a = \frac{(0.9 S_{ut})^2}{Se} = 304 \text{ kpsi}$$

$$b = \frac{-0.333 (\log 0.9 S_{ut}^2)}{Se} = -0.144$$

$$N = \frac{\sigma_a}{a}^{1/b} = 4.4E+3 \text{ cycles}$$

The axle should suffice for prototype testing.

Improvements to Axle Design

Changes in the following areas may be made for the design of the production model's axle.

1. material
2. axle diameter
3. material processing (heat treating, machining, etc....)
4. machine weight

Estimates For Shaft Slope at Auger Bearings

d	0.90	inches	axle diameter in snap ring groove
F	434	pounds	force from wheel (half weight)
a	4.00	inches	distance from middle of center of wheel (axially and radially)
E	30.0 E+6	psi	modulus of Elasticity
I	0.0358	inches ⁴	moment of inertia
L	61.75	inches	Length between wheels center to center (as with x)

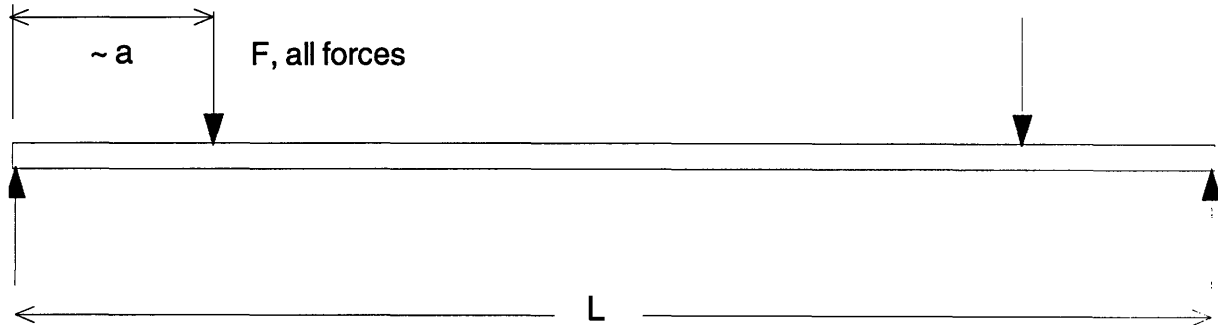

ANSWER

Using equation for slope of a beam with simple supports and twin loads

2.49 degrees slope at snap ring (next to bearing location)

Underdesigned! Deflection is too large!

Appendix G

Hopper

- prints detailing hopper features and dimensions

Hopper Body - Finished Side View

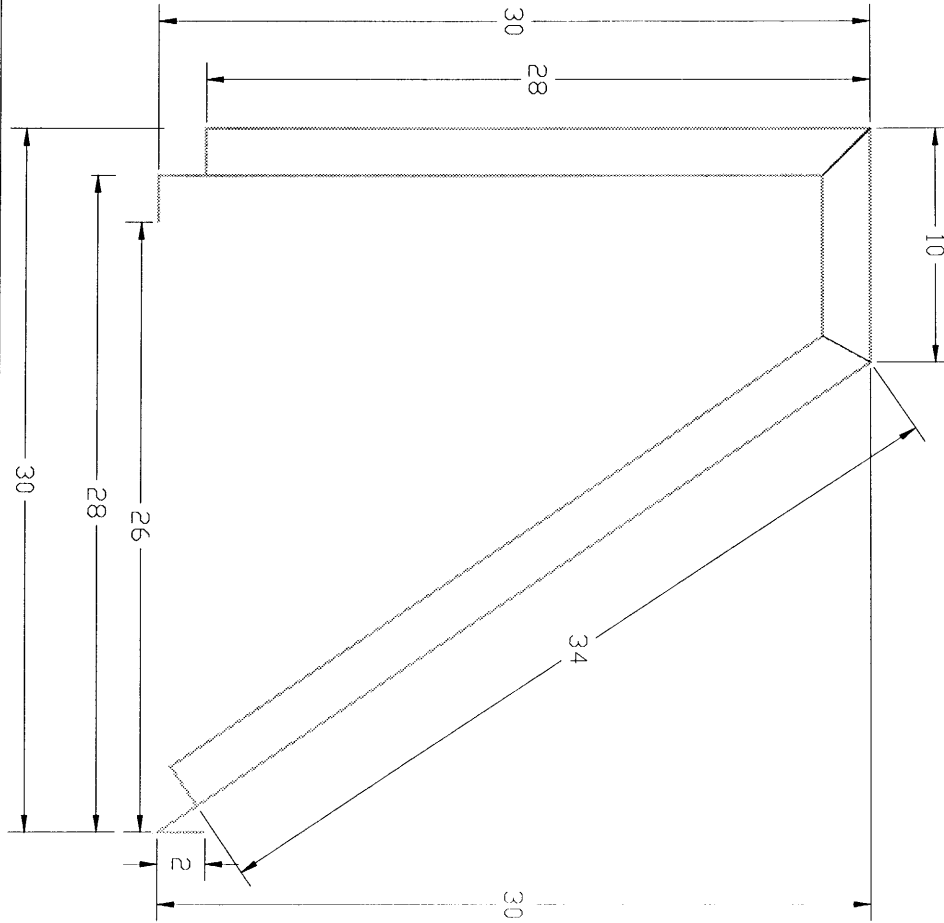

- Material: 16 guage steel
- All dimensions in inches
- All dimensions are outside bends unless otherwise specified
- All tabs 1.5" wide
- Weld at corners and bending tab interfaces to seal

TITLE: Hopper Body - Side View Finished		
NAME: Martin L. Culpepper		
DATE: 11/14/95	SCALE: 1:8	REV #: B
TOLERANCES: +/- 0.060" unless otherwise specified		

M.I.T. Department of Mechanical Engineering
CHECKED BY: Martin L. Culpepper
CHECK DATE: 11/14/95
NOTES: All dimensions given are OUTSIDE of folded edges.

Phone (617) 253-1953
Alias: (617) 539-4986

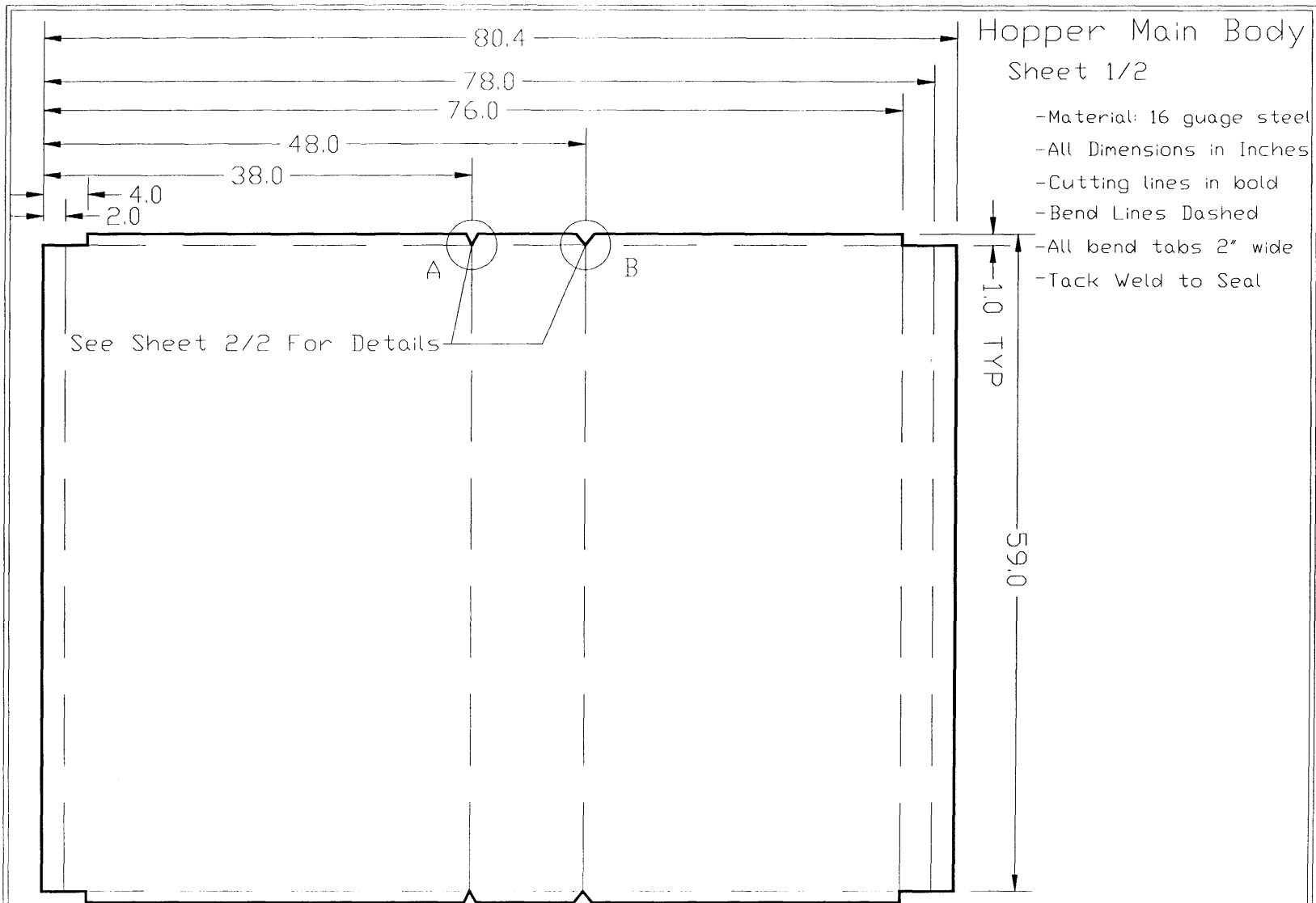

TITLE: Hopper Main Body, Sheet 1/2			M.I.T. Department of Mechanical Engineering		Phone: (617) 253 1953
NAME: Martin L. Culpepper			CHECKED BY: Martin L. Culpepper		
DATE: 11/14/95	SCALE: 1:1	REV #: B	CHECK DATE: 11/14/95		
TOLERANCES: ± 0.060" unless otherwise specified			NOTES: All dimensions given are OUTSIDE folded edges		Alias: (617) 539 4986

Hopper Main Body

Sheet 2/2

- Material: 16 guage steel
- All Dimensions in Inches
- Cutting lines in bold
- Bend Lines Dashed

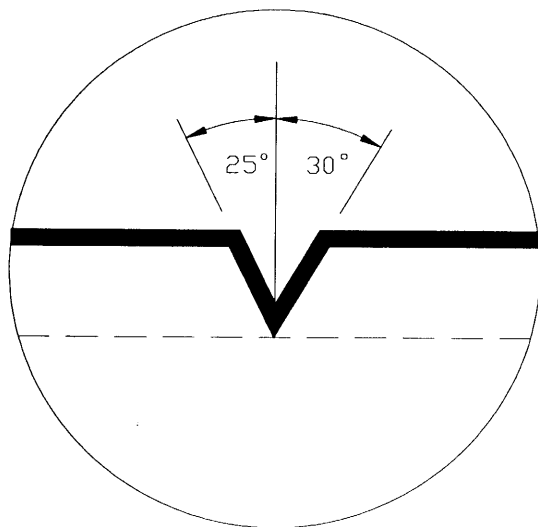

Detail A

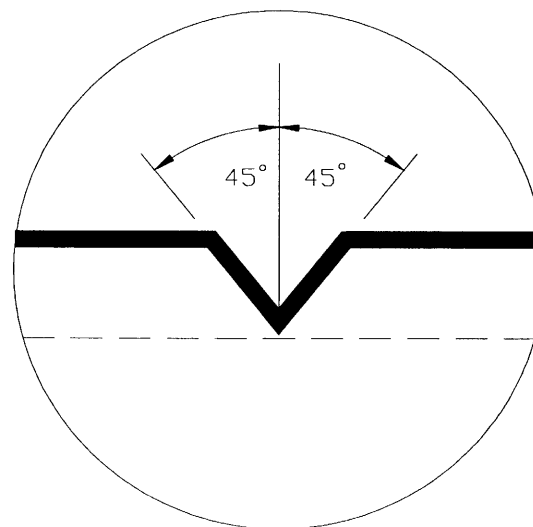

Detail B

TITLE: Hopper Main Body, Sheet 2/2		
NAME: Martin L. Culpepper		
DATE: 11/14/95	SCALE: 1:1	REV: B
TOLERANCES: +/- .5° unless otherwise specified		

M.I.T. Department of Mechanical Engineering		Phone: (617) 253-1953
CHECKED BY: Martin L. Culpepper		
CHECK DATE: 11/14/95		Alias: (617) 539-4986
NOTES:		

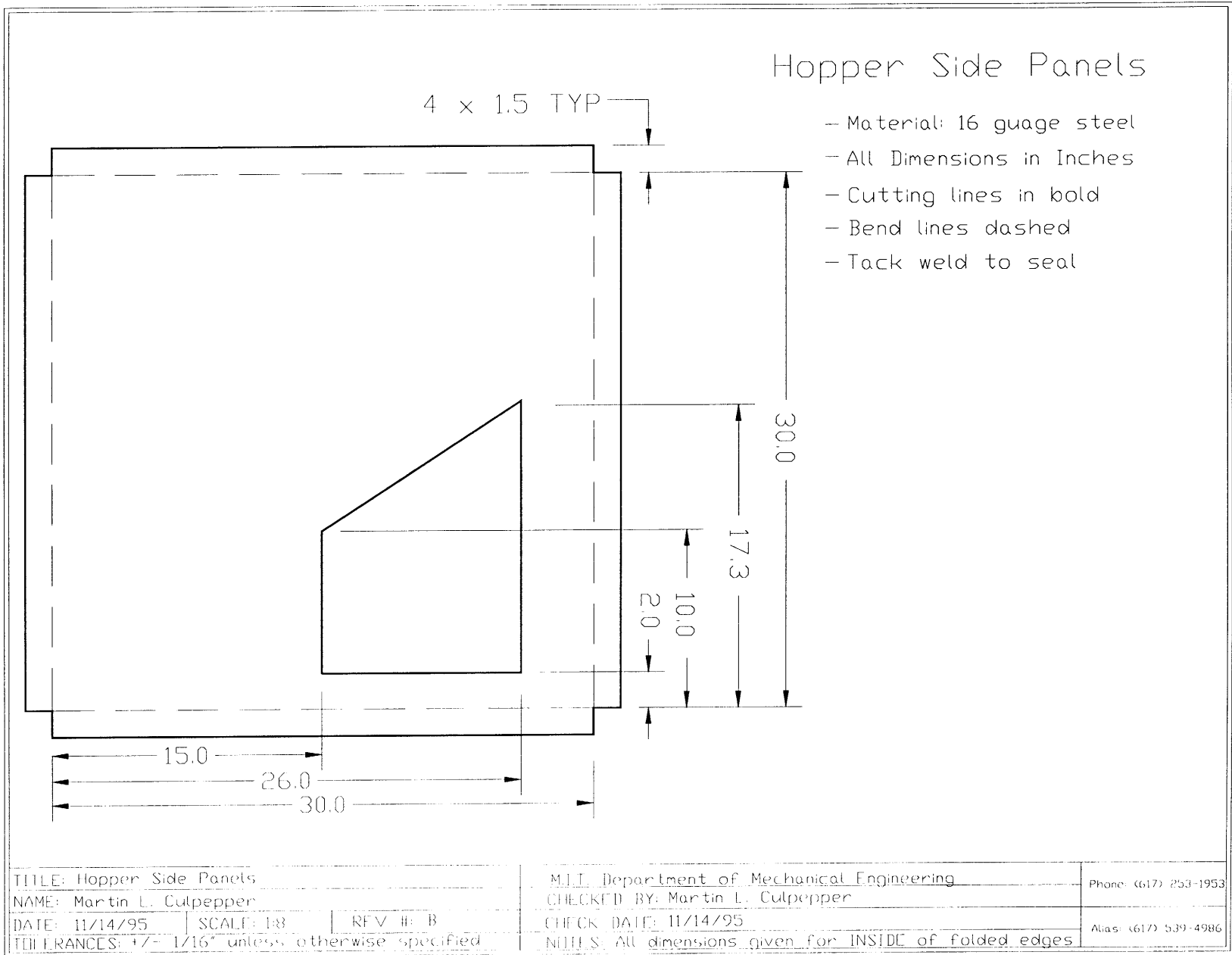

Prototype Door Latch

-Material: 1020 Steel Plate, 1/4" Thick

-All Hole Diameters: $0.500^{+0.0000}_{-0.0002}$

-Dimension A: $0.7250^{+0.0002}_{-0.0000}$

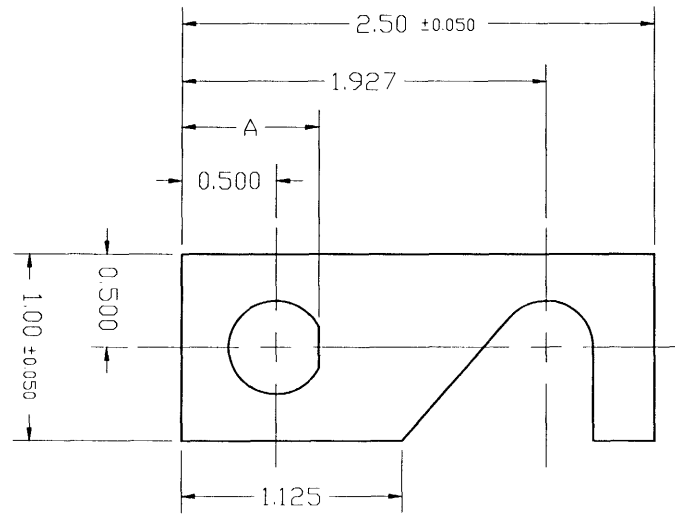

319

TITLE: Prototype Door Latch

NAME: Martin L. Culpepper

DATE: 05/01/96

SCALE: 1:1

REV #: A

TOLERANCES: +/- 0.002" unless otherwise stated

M.E. Department of Mechanical Engineering

CHECKED BY: Martin L. Culpepper

CHECK DATE: 05/01/96

NOTES: All Dimensions in Inches

Phone: (617) 253-1953

Alias: (617) 539-4986

Hopper Door Latch Shaft

- Material: 4140 Steel, 1/2" HRS
- * Length Free of Threads
- Flats Extend From Shaft End To Groove
- Thread: 1/2-20 UNF
- Dimension A: $0.4750'' \pm \begin{smallmatrix} 0.0009 \\ 0.0003 \end{smallmatrix}$
- Ends of Rod Past Grooves Dimensioned
As Shown, Middle Rod Diameter: 0.500 ± 0.005

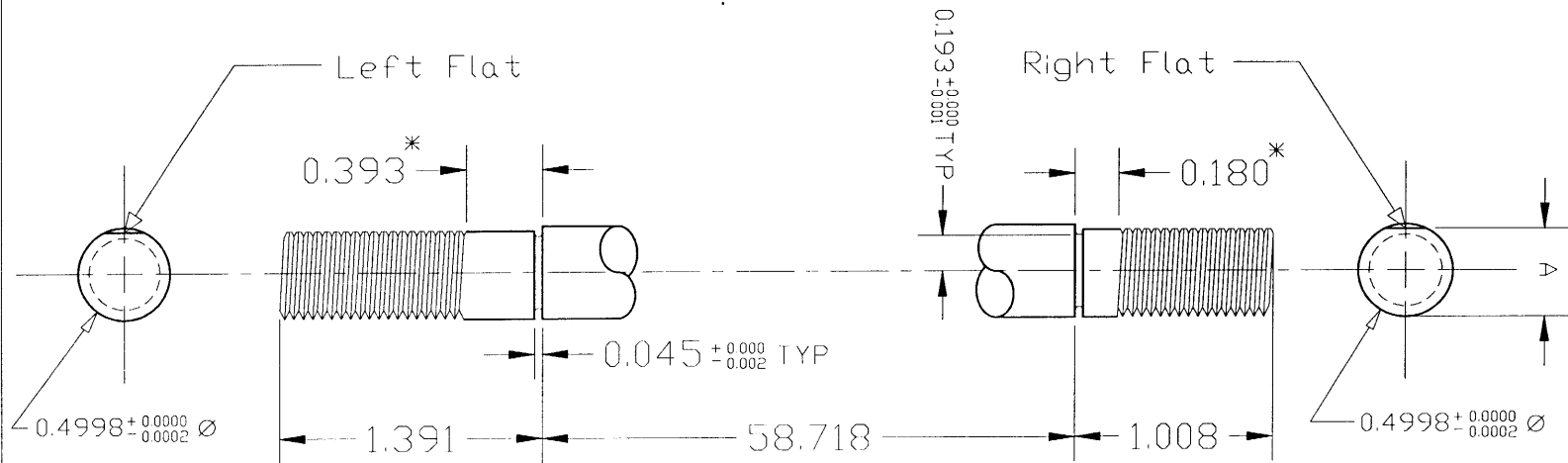

TITLE: Hopper Door Latch Shaft			M.I.T. Department of Mechanical Engineering		Phone: (617) 253-1953
NAME: Martin L. Culpepper			CHECKED BY: Martin L. Culpepper		
DATE: 05/01/96	SCALE: 1:1	REV #: A	CHECK DATE: 05/01/96		
TOLERANCES: +/- 0.005" unless otherwise stated			NOTES: All Dimensions in Inches		Alias: (617) 539-4986

Prototype Door Lever

-Material: 1020 Steel, 1/4" Thick

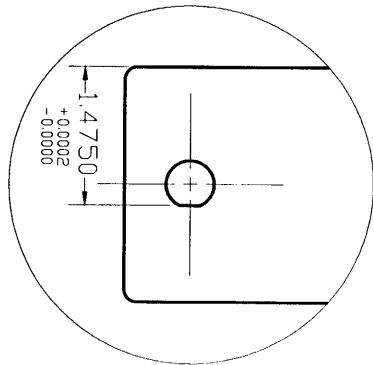
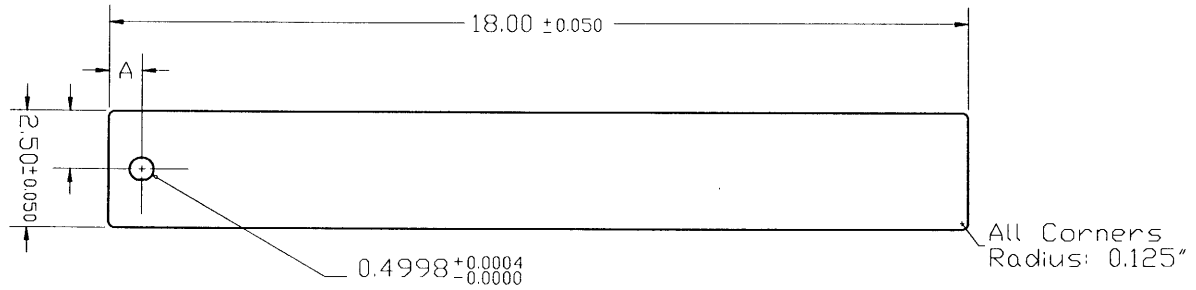

321

TITLE: Prototype Door Lever		
NAME: Martin L. Culpepper		
DATE: 05/01/96	SCALE: 1:4	REV #: A
TOLERANCES: +/- 0.003" unless otherwise stated		

M.I.T. Department of Mechanical Engineering	Phone: (617) 253-1953
CHECKED BY: Martin L. Culpepper	
CHECK DATE: 05/01/96	
NOTES: ALL Dimensions in Inches	Alias: (617) 539-4986

Appendix H

Frame

- prints detailing features and dimensions of the prototype frame

Prototype Cross Supports

- Material: 2X8 Pine Wood

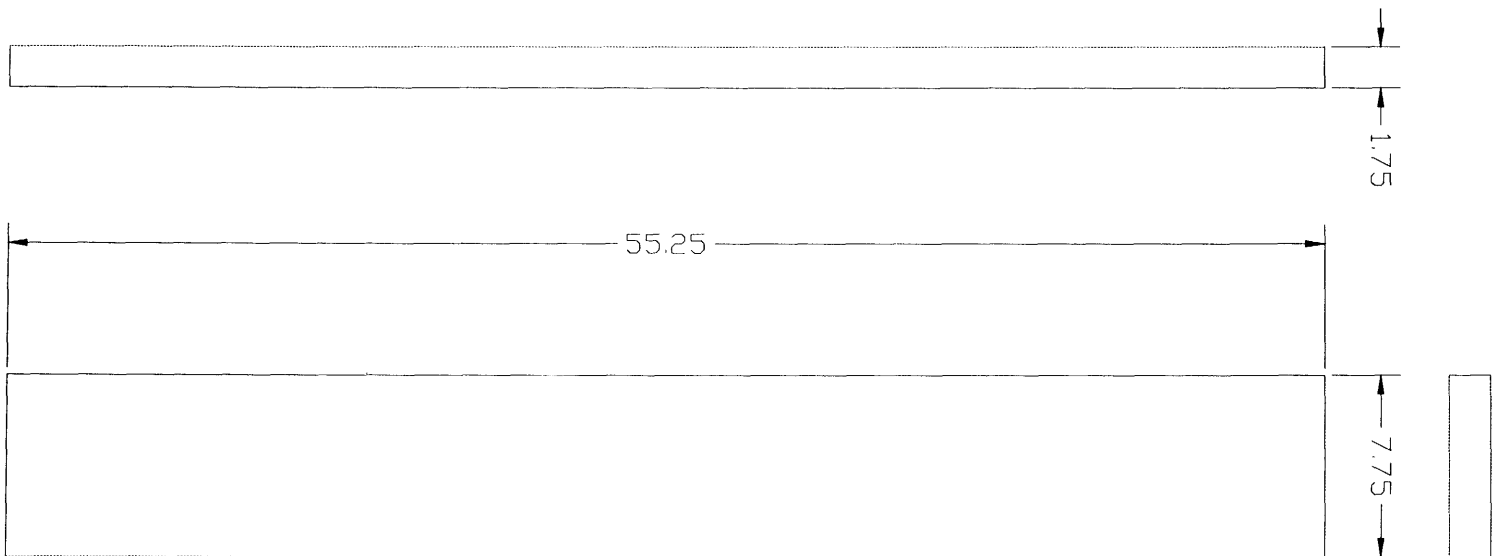

323

TITLE: Prototype Cross Supports		M.I.T. Department of Mechanical Engineering		Phone: (617) 253 1953
NAME: Martin L. Culpepper		CHECKED BY: Martin L. Culpepper		
DATE: 12/20/95	SCALE: 1:8	REV #: B	CHECK DATE: 12/20/95	Alias: (617) 539-4986
TOLERANCES: +/- 0.050" unless otherwise stated		NOTES:		

Prototype Front Support

- Material: 2X4 Pine Wood

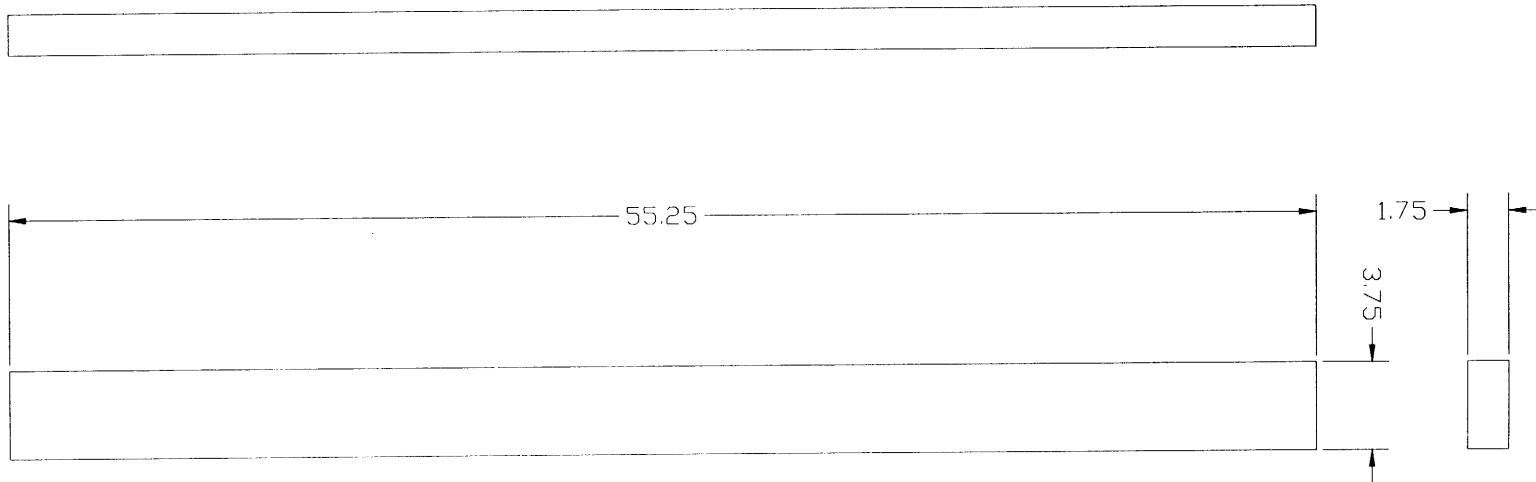

TITLE: Prototype Front Support
NAME: Martin L. Culpepper
DATE: 01/25/96 SCALE: 1/8 REV #: B
TOLERANCES: ±.050" unless otherwise stated

M.I.T. Department of Mechanical Engineering
CHECKED BY: Martin L. Culpepper
CHECK DATE: 01/25/96
NOTES:

Phone: (617) 253-1953
Alias: (617) 539-4986

Prototype Platform

- Material: 3/4" Ply Wood

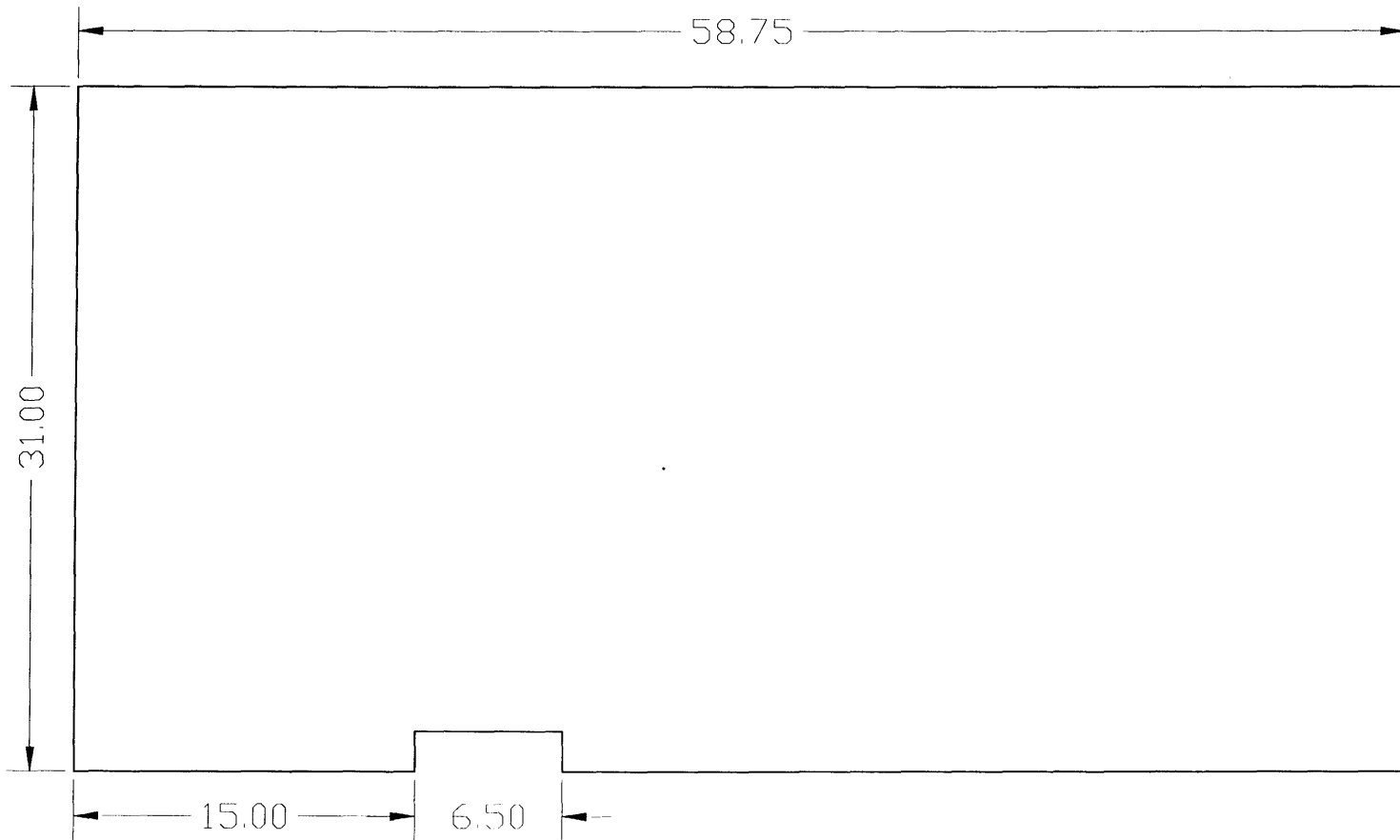

325

TITLE: Prototype Platform		M.I.T. Department of Mechanical Engineering		Phone: (617) 253-1953
NAME: Martin I. Culpepper		CHECKED BY: Martin I. Culpepper		
DATE: 01/24/96	SCALE: 1:8	REV: B	CHECK DATE: 01/24/96	
TOLERANCES: ±.01" unless otherwise stated		NOTES:		Alias: (617) 539-4986

Prototype Rear Support

- Material: 2X8 Pine Wood

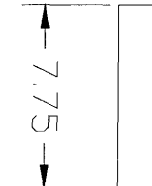
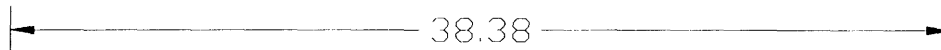

326

TITLE: Prototype Rear Support		
NAME: Martin L. Culpepper		
DATE: 01/24/96	SCALE: 1:8	REV: B
TOLERANCES: +/- 0.10" unless otherwise stated		

M.E. Department of Mechanical Engineering
CHECKED BY: Martin L. Culpepper
CHECK DATE: 01/24/96
NOTES:

Phone: (617) 253-1953

Fax: (617) 539-4986

Prototype Side Support

- Material: 2X4 Pine Wood

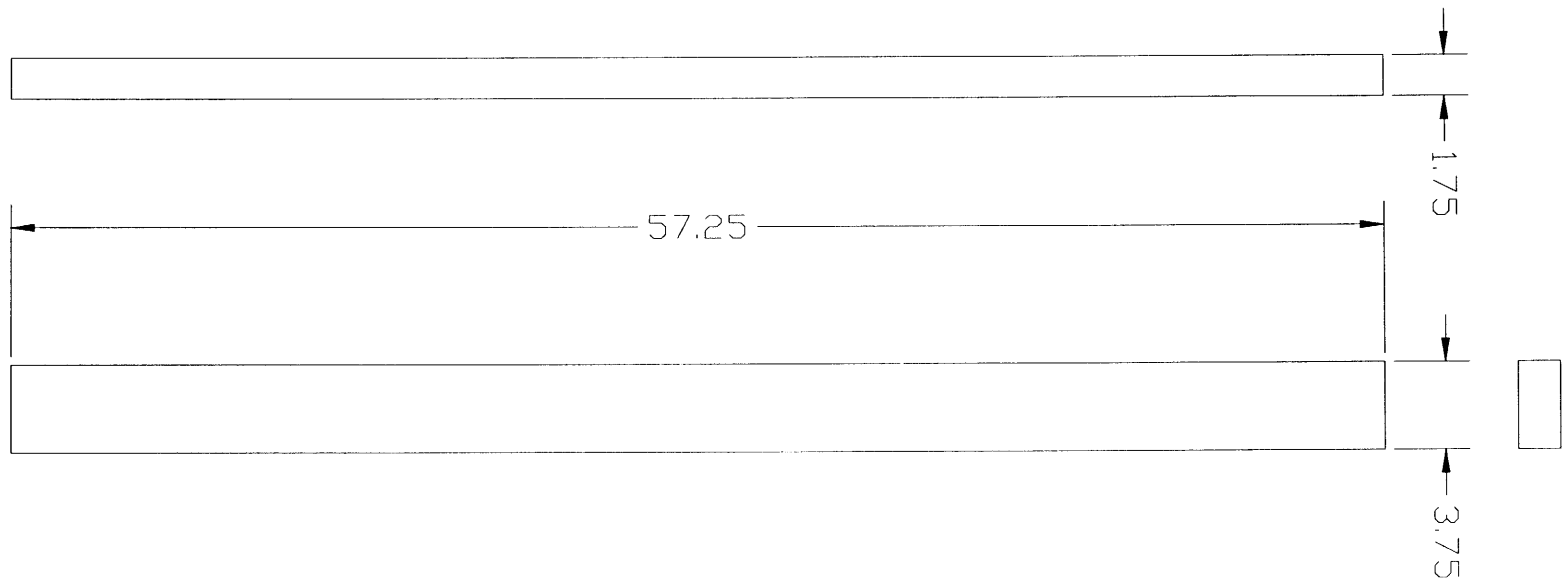

327

TITLE: Prototype Side Support
NAME: Martin L. Culpepper
DATE: 12/18/95 SCALE: 1:8 REV #: A
TOLERANCES: +/- 0.10" unless otherwise stated

M.I.T. Department of Mechanical Engineering
CHECKED BY: Martin L. Culpepper
CHECK DATE: 12/18/95
NOTES:

Phone: (617) 253-1953
Alias: (617) 539-4986

Prototype Spine

- Material: 2X9 Pine Wood

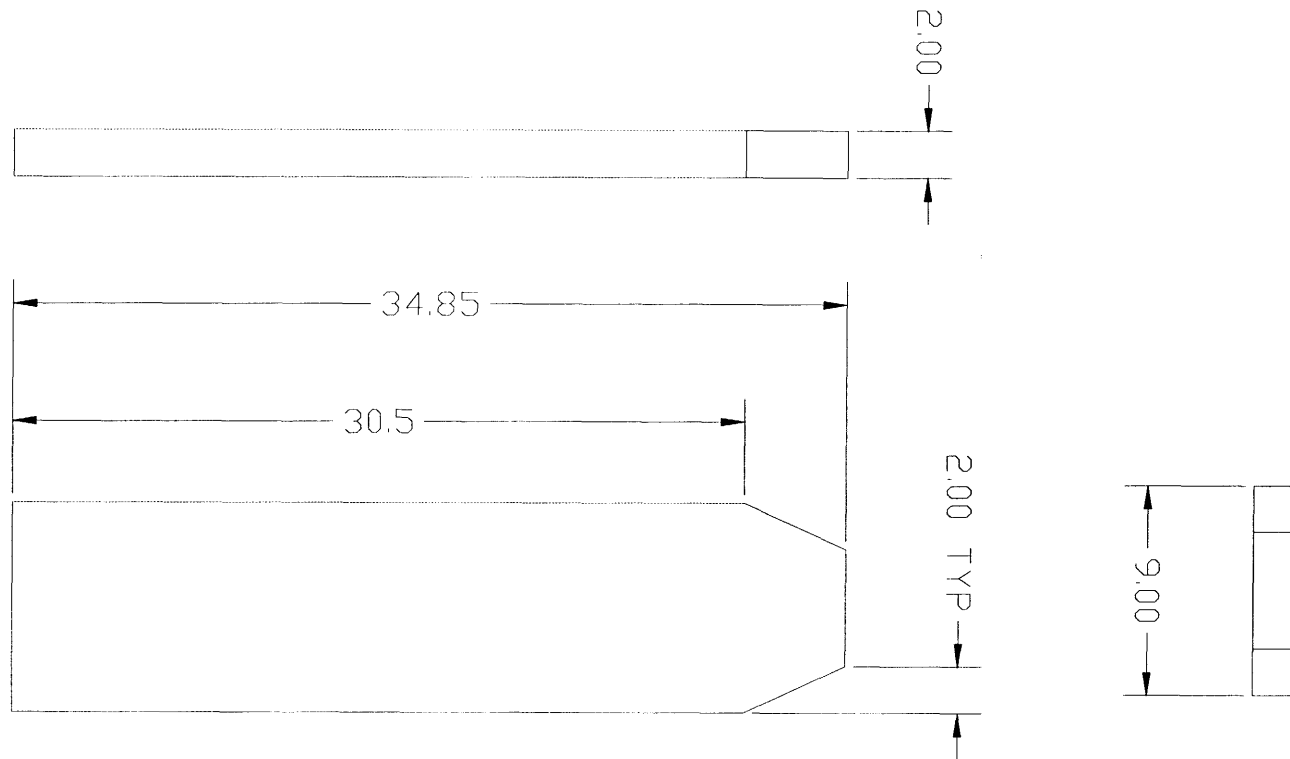

328

TITLE: Prototype Spine			M.I.T. Department of Mechanical Engineering		Phone: (617) 253-1953
NAME: Martin I. Culpepper			CHECKED BY: Martin I. Culpepper		
DATE: 01/24/96	SCALE: 1:8	REV: H: C	CHECK DATE: 01/24/96		Alias: (617) 539-4986
TOLERANCES: +/- 0.10" unless otherwise stated			NOTES:		

Prototype Frame Upper Support

-Material: 2x8 Pine Wood

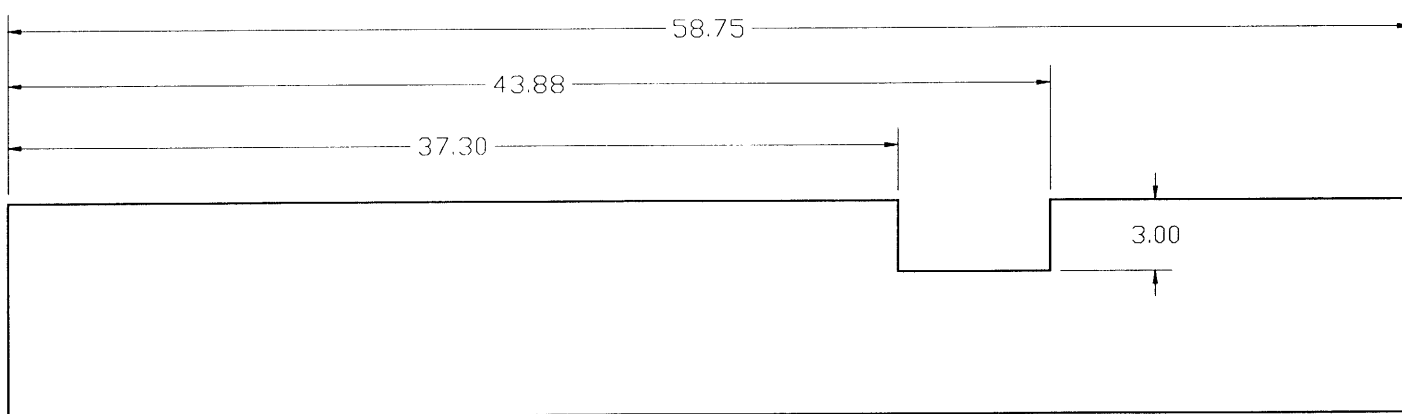

330

6075-45

TITLE: Prototype Frame Upper Support			M.I.T. Department of Mechanical Engineering		Phone: (617) 253-1953
NAME: Martin L. Culpepper			CHECKED BY: Martin L. Culpepper		
DATE: 03/16/96	SCALE: 1:8	REV. #: A	CHECK DATE: 03/16/96		Atas: (617) 539-4986
TOLERANCES: ± 0.050" unless otherwise stated			NOTES: All Dimensions in Inches		