



VARIATION OF MECHANICAL CHARACTERISTICS FOR THIN WALL TUBES PROCESSED IN ULTRASONIC FIELD

Mihai SUSAN¹, Dragoş Cristian ACHIŢEI¹, Roxana Gabriela ŞTEFANICĂ¹, Bogdan Lucian GAVRILĂ¹

¹Gheorghe Asachi Technical University of Iaşi, Faculty of Material Science and Engineering

²Institutul de Fizică Aplicată din Chişinău, Republica Moldova

email: mihaisusan@yahoo.com

ABSTRACT

The paper presents the variation of mechanical characteristics of resistance and plasticity for thin wall tubes made of stainless steel 10TiNiCr180, processed in ultrasonic field. Decrease of mechanical characteristics of resistance and increase of plasticity ones in tubes processing in ultrasonic field, with respect to classic technology, are made on account of cold hardening reduction, implicitly metal-tool contact friction. Tubes processing is made through drawing without inner guidance/to empty, using convergent conic dies made of metallic carbides.

KEYWORDS: thin walls tubes, stainless steel, ultrasonic field, cold hardening, convergent conic dies, mechanical characteristics.

1. Introduction

The paper discusses the influence of the relative drawing speed expressed as the ratio v_{tr}/v_v (v_{tr} is the drawing speed and v_v is the vibration speed of the die) on the resistance and plasticity mechanical characteristics and on the safety of drawing in

processing tubes with ultrasonic vibrations applied to the auger die on drawing direction "ultrasonic vibration drawing - UVD" or UVD system [1, 3].

The experiments are made on 10TiNiCr180 / AISI321 stainless steel tubes through drawing without interior guide.

The principle scheme of the processing tubes installation in UVD system/UVD technology is presented in figure 1.

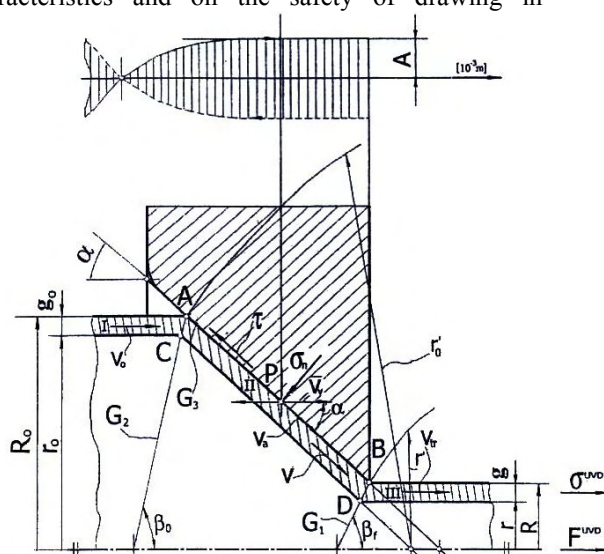

1 - semi-finished tube; 2 - die;
3 - processed tube: g_0 and g - wall thickness-semi-finished and processed tube; v_0 - speed of semi-finished tube; v_{tr} - drawing speed; v_a - slipping speed of the metal; v - speed of the semi-finished tube in deformation zone;
 τ - tangential shearing stress;
 σ_n - normal stress in a certain point at metal-tool contact; P - certain point at metal-tool interface; α - half angle of the die opening.

Fig. 1. The scheme of ultrasonic drawing of the tubes in UVD system.

The scheme of ultrasonic drawing of the tubes in UVD system is presented in figure 1.

In UVD system processing tubes, with the die situated in the maximum of waves oscillations and activated on drawing direction, produces in the deformation focus the reduction of metal-tool contact friction, respectively cold hardening, with direct influence on mechanical characteristics and on the safety of drawing. The reduction of metal-tool contact friction, respectively cold hardening, in UVD system processing tubes is explained on the basis of "the reverse mechanism of the intermediate friction force" [1].

In order that the oscillated system should not get out of resonance in the die activation (located in the maximum of oscillation waves and activated on drawing direction) are used reflectors of ultrasonic energy.

The role of the ultrasonic energy reflectors is to permit the making of a stable system of stationary waves in the semi-finished and processed tube.

The positioning of ultrasonic energy reflectors is realized at well defined distances—resulted on the basis of the making mechanism of a stable system of stationary waves in the tube. The peculiarities of plastic deformation of the metal in UVD system of processing tube, unto CT classical technology, consist in the reduction of metal-tool contact friction determined by the mechanics of plastic deformation – fractioned deformation or in impulses at a complete oscillation period (considering Coulomb type friction).

The variation movement of waves (u), of vibration speed of the die (v_v) and drawing speed at a complete oscillation period (T) is presented in figure 2.

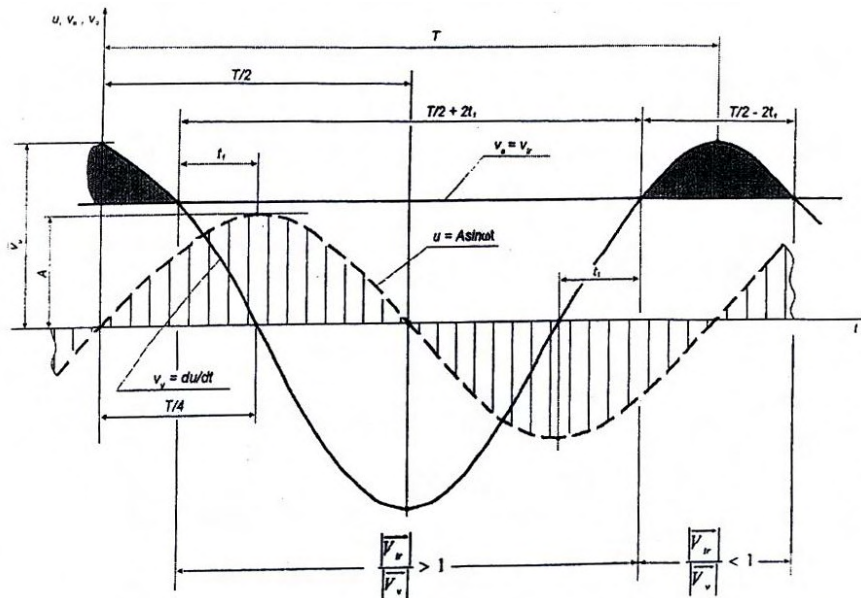

Fig. 2. The variation movement of the waves (u), the vibration speed of the die (v_v) and drawing speed (v_{tr}) at a complete oscillation period (T)

2. The mechanics of plastic deformation

It is observed from figures 2 and 3 that a P point arbitrarily chosen to the metal-tool interface participates in two movements: advance on the generator of plastic deformation tool cone with v_a speed and vibration movement with v_v speed. The vector of the friction force (\vec{F}_f) in the case of classical technology CT opposes to movement direction of the metal (\vec{v}_a) and in the case of UVD technology opposes to the direction of the resultant vector – the composition between \vec{v}_v and \vec{v}_a . Practically, in UVD system, at a complete oscillation

period (T), the deformation of the metal is realized in fractions or in impulses.

Thus during $T/2 + 2 t_1$, when $\left| \frac{\vec{v}_{tr}}{\vec{v}_v} \right| > 1$, is produced the proper deformation of the metal and during $T/2 - 2 t_1$, when $\left| \frac{\vec{v}_{tr}}{\vec{v}_v} \right| < 1$ takes place at the most elastic deformation.

In classic technology-CT, friction coefficient (μ) is determined with the relation [5]:

$$\mu^{CT} = \frac{\tau}{\sigma_n} \quad (1)$$

In UVD technology, friction coefficient (μ^{UVD}) is smaller than in classic technology CT with the term which includes the influence of ultrasonic activation of the die, justified by $4t_1/T$ noted with ξ .

Under these conditions, the size of the coefficient (μ^{UVD}) has the expression:

$$\mu^{UVD} = \frac{\tau}{\sigma_n} - \frac{4t_1}{T} \cdot \frac{\tau}{\sigma_n} = \mu^{CT} \left(1 - \frac{4t_1}{T} \right) \quad (2)$$

Or $\mu^{UVD} = \mu^{CT} (1 - \xi)$, with $0 \leq \xi \leq 1$.

Considering the movement of the ultrasonic waves after movement law $u = A \sin \omega t$; the vibration speed is determined as the movement time derivative:

$$v_v = \frac{du}{dt} = A \omega \cos \omega t \quad (3)$$

The maximum value of vibration speed of the die (v_v) gets under the condition $\cos \omega t = 1$ meaning:

$$\vec{v}_v = \omega \cdot A = 2\pi f \cdot A \quad (4)$$

For small angles of dies opening (α) / $\alpha \leq 120^\circ$ - it can be considered $v_a \approx v_{tr}$ because $\cos \alpha \rightarrow 1$.

Equalizing the two speeds $v_{tr} = v_v$ results t_1 with the expression: $t_1 = \frac{1}{\omega} \arccos \frac{v_{tr}}{v_v}$.

Taking into consideration the determined expression for t_1 and the factor of effective influence of the ultrasonic oscillations on the metal-tool contact friction (ξ) it results the expression for μ^{UVD} :

$$\mu^{UVD} = \mu^{CT} \left(1 - \frac{2}{\pi} \arccos \frac{v_{tr}}{v_v} \right),$$

with

$$v_{tr} / v_v \leq 1,0 \quad (5)$$

It is noticed from the last relation that relative drawing speed or the ratio v_{tr} / v_v has direct influence on the size of friction coefficient in UVD system processing tubes (μ^{UVD}) and implicitly on the drawing force (F^{UVD}).

It can be concluded that plastic deformation in tubes drawing in UVD system is accomplished fractionatedly or in impulses: the proper plastic deformation during $T/2 + 2 t_1$ at a complete oscillation period (T), and without plastic deformation-at the most elastic deformation during $T/2 - 2 t_1$.

3. Experiments and obtained results

The experiments are made on tube samples of stainless steel 10TiNiCr180 / AISI 321 having the dimensions: $D_0 = 4,85$ mm, $g_0 = 0,70$ mm, the length is 1500 mm with one polished end and solution heat treated. It is used a classical drawing machine – drawn from coil in coil which develops a drawing force of $15 \cdot 10^4$ [N].

The scheme of the oscillated system used in experiments is presented in figure 4.

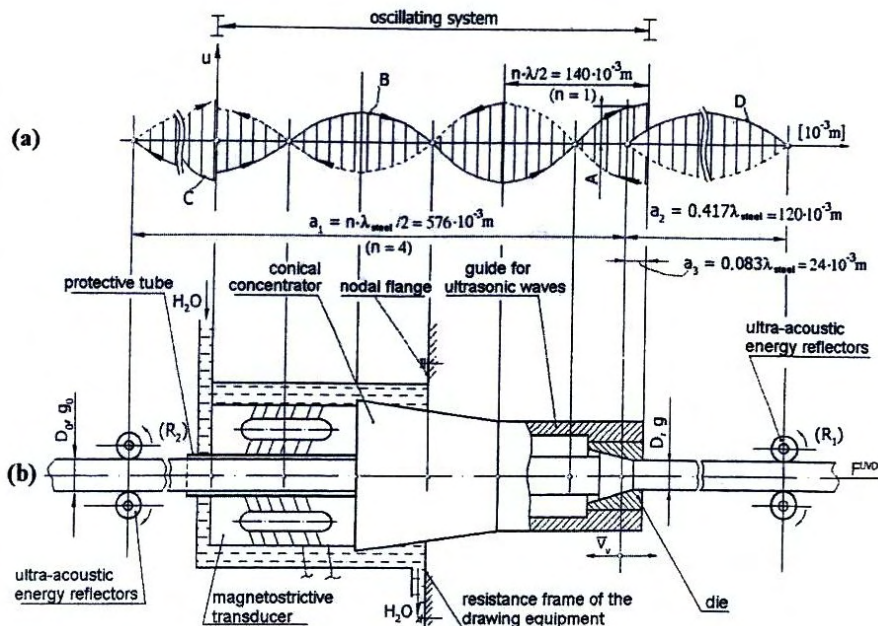

Fig. 3. The scheme of the oscillated system used in experiments:
 a) the oscillation of the waves; b) the proper scheme: — progressive wave, ---regressive wave.

It is used for experiments the ultrasounds generator GUS P-1000 with magnetostriction

transducer, with actual output of 1000 W and resonance frequency of 17500 Hz, [3]. In order to



succeed in processing the tubes in UVD system are used ultrasonic power reflectors/ presser rolls (R_1) and (R_2) located at the distances a_2 respectively a_1 resulted on the basis of the making mechanism in the processed and semi-finished tube of a stable system of stationary waves (λ is wave length: $\lambda=c/f$, where c is the propagation speed of ultrasounds and f is resonance frequency). For processing the tubes are used conical convergent dies with WCr core, with the angle $\alpha=8^\circ$, the opening of the die. The experiments are made with constant drawing speed ($v_{tr} = 0,33$ m/s) and five values of the oscillation amplitudes of the die, $A = 5, 10, 15, 20, 25$ μm , meaning (based on relation (4) different values of the vibration speed (\vec{v}_v): 0.55; 1.09; 1.65; 2,20 and 2.74 m/s. The section reduction of the processed tube r , $\% = ct$, is 23% ($D = 4.32$ mm and $g = 0.65$ mm).

The processing of tube samples, UVD and CT technologies, is realized through singular drawing on five sets of samples A, B, C, D and E, selected

according on the value of the relative drawing speed (v_{tr}/v_v).

Drawing force F^{CT} and F^{UVD} , the mean of five determinations, corresponding to sample sets A...E, is determined experimentally with the help of force pick-ups (DT106000) using the tensometer bridge type N2314. Also, experimentally, it is measured the drawing speed (v_{tr}) and the amplitude of the oscillation (A). In order to evaluate the resistance and plasticity mechanical characteristics, in accordance with SR-EN 10002-1/95 norms, is used the tension test machine type MTS 81024. The recorded results, through traction test, for R_m , $R_{p0,2}$ and A_5 also represent the average of the five determinations. The safety coefficient of the drawing is determined with relation: $C = 100[(S \cdot R_m/F)]$, % - where S is the plan area for the processed tube, R_m – the average fracture strength and F – drawing force (F^{CT} respectively F^{UVD}). The obtained experimental results are synthetically presented in table 1.

Table 1. Obtained experimental results

Samples	Technological parameters			Safety coefficient		Mechanical characteristics					
	$\frac{v_{tr}}{v_v}$	F^{CT}	F^{UVD}	C^{CT}	C^{UVD}	CT	CT	CT	UVD	UVD	UVD
		[N]		[%]		$R_{p0,2}$	R_m	A_5	$R_{p0,2}$	R_m	A_5
A	0.6	812	676	4.89	5.62	352	532	32.2	349	509	33.2
B	0.3	812	637	4.89	5.83	352	532	32.2	348	498	33.6
C	0.2	812	597	4.89	6.10	352	532	32.2	343	488	34.0
D	0.15	812	574	4.89	6.22	352	532	32.2	335	478	34.5
E	0.12	812	545	4.89	6.29	352	532	32.2	328	459	35.4

The percentage relative reductions ΔF , ΔC , $\Delta R_{p0,2}$, ΔR_m and ΔA_5 are calculated with the next

$$\text{relations [1]: } \Delta F = \frac{F^{CT} - F^{UVD}}{F^{CT}} \cdot 100[\%]$$

$$\Delta C = \frac{C^{UVD} - C^{CT}}{C^{UVD}} \cdot 100[\%]$$

$$\Delta R_{p0,2} = \frac{R_{p0,2}^{CT} - R_{p0,2}^{UVD}}{R_{p0,2}^{CT}} \cdot 100[\%]$$

$$\Delta R_m = \frac{R_m^{CT} - R_m^{UVD}}{R_m^{CT}} \cdot 100[\%]$$

$$\Delta A_5 = \frac{A_5^{UVD} - A_5^{CT}}{A_5^{UVD}} \cdot 100[\%] \quad (6)$$

The calculated relative reductions are synthetically presented in table 2.

Table 2. The calculated relative reductions.

Samples	v_{tr}/v_v	ΔF	ΔC	$\Delta R_{p0,2}$	ΔR_m	ΔA_5
		[%]				
A	0.60	16.74	12.98	0.85	4.32	3.01
B	0.30	21.55	16.12	1.13	6.39	4.16
C	0.20	26.47	19.83	2.55	8.27	5.29
D	0.15	29.31	21.38	4.83	10.15	6.66
E	0.12	32.88	22.25	6.81	13.72	9.03

In figure 4 is presented the variation of percentage relative reductions ΔF , ΔC , $\Delta R_{p0.2}$, ΔR_m and ΔA_5 which represent, in fact, the efficiency of the

new technology, the drawing of the tubes in UVD tubes with respect to classic technology CT.

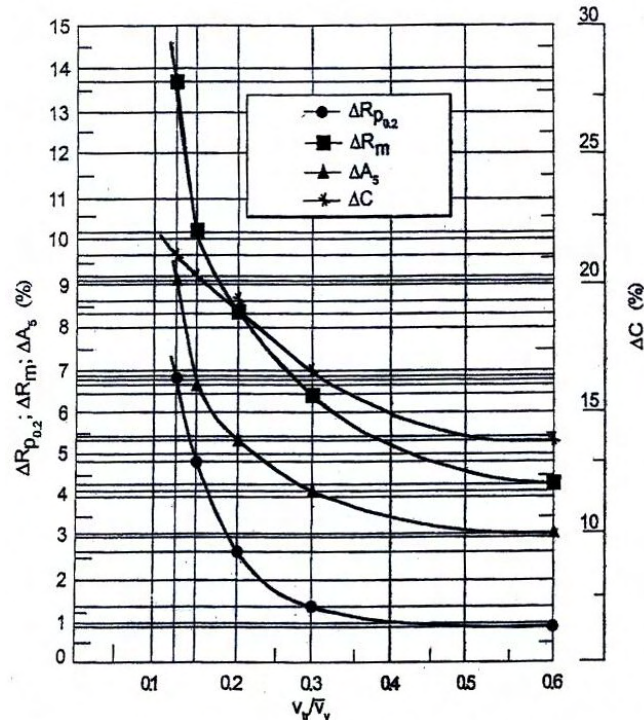

Fig.4. Variation of the relative reductions of the field stress ($\Delta R_{p0.2}$), tensile strength (ΔR_m) and the ultimate strain (ΔA_5) and relative increase of the safety coefficient of drawing (ΔC) as a function of the drawing rate (v_{tr}/v_v) at 10TiNiCr180 (AISI 321) austenitic stainless steel tubes processing.

It is noticed a decrease of resistance mechanical characteristics by keeping a plasticity reserve for smaller values of relative drawing speed (v_{tr}/v_v) by increasing the safety of drawing. These direct influences of the relative drawing speed on the resistance and plasticity mechanical characteristics and on the safety drawing coefficient are determined by the reduction of metal-tool contact friction, respectively cold hardening, due to the fractioned or in impulses deformation of the metal. The size of the reduction of metal-tool contact friction can be the value of friction coefficient (μ^{UVD}) which can be calculated with relation (5). The new technology of processing the tubes in UVD system presents practical interest when $v_{tr}/v_v \ll 1,0$. The v_{tr}/v_v ratio also presents practical importance because v_{tr} defines the technological productivity and v_v permits the election of the process installation and transfer of ultrasonic power in the basis of relation (4).

4. Conclusions

The paper emphasizes the influence of relative drawing speed or v_{tr}/v_v ratio in processing the tubes without interior guide with direct influence on the resistance (R_m and $R_{p0.2}$) and plasticity (A_5) mechanical characteristics and on the safety of drawing (C).

The experiments are made on tube samples of 10TiNiCr180 / AISI 321 stainless steel.

References

- [1]. Susan, M., *Tragerea metalelor cu vibratii ultrasonice*. Editura CERMI, Iasi, 2007.
- [2]. Cazimirovici, E., s.a., *Teoria si tehnologia deformarii prin tragere*, Editura Tehnica, Bucuresti, 1990.
- [3]. Contract CEEX 293/2006.