



SEVERE PLASTIC DEFORMATION AN ADVANCED METHOD FOR NANOSTRUCTURING SHAPE MEMORY ALLOYS

Gheorghe GURAU, Carmela GURAU,
Dinel TANASE, Elena DRUGESCU

"Dunarea de Jos" University of Galati
email: gheorghe.gurau@ugal.ro

ABSTARCT

Severe plastic deformation (SPD) is an advanced plastic deformation. In this process nanostructuring metals and alloys may be produced. Nanostructured shape memory alloys are associate with a very high strength, toughness, fatigue life and wear resistance. In recent, bulk nanostructured SMA are used for medicine advanced applications and smart micro devices. In this paper we present the concept and principles SPD. There are two distinct methods: Equal Channel Angular Pressing ECAP or Equal Cannel Angular Extrusion –ECAE and High Pressure Torsion – HPT. Also we present some results about nanostructuring a hard deformable shape memory alloy using a original HPT, and a improved ECAE device.

KEYWORDS: severe plastic deformation, ECAP, HPT

1. Introduction

Herbert Gleiter presents in 1989 the concept of nano crystalline materials (ultrafine grained materials with a grain size under 100 nm) [1]. Since then this advanced material class has rapidly developed because technological and scientific importance.

Nanocrystalline materials contained extremely large fraction grains boundaries with a special atomic structure.

As a result, nanomaterials should have unusual properties. It is a very well known that grain refinement provides mechanical strength and thus can expect ultrafine grained materials to possess very high strength. Moreover, introduction of high density dislocations in SPD processed nonmetals may result in even greater hardening. In this case we have decreases ductility and can say that the strength and ductility are opposing characteristics.

Nanostructured metals show unique combination of exceptionally high strength and ductility.

Bulk nanostructured materials may be obtained in different ways: from nanopowders mixed in ball milling or mechanical alloying and compacting or by inert gas condensation.

The named methods have inconvenient like porosity or small dimensions (1 mm in thickness and 10nm in diameter).

A new approach in metallic nanomaterials processing is the plastic deformation using severe deformation degree. From the very beginning severe plastic deformation have been developed two techniques. Those techniques are – high pressure torsion (HPT) and equal channel angular pressing (ECAP) or equal chanell angular extrusion (ECAE)

1.1. Equal Channel Angular Extrusion

Equal channel angular extrusion was developed in 1980s in the former Soviet Union [2]. Method provides smallest grain size (1-10 μm) with certain advantage in comparison with classic thermo-mechanical processes.

One advantage is that the method is applicable for all metallic material no mater chemicals composition, mono or polycrystalline without modification process parameters. ECAE provide de capability of produce in large bulk samples submicrometers or nanometers grain size that cannot be obtained using non conventional procedures. On the other hand ECAE may be integrated into a rolling line or wires line for log products. During the ECAE process metal billet is pressed through a die which present two channels equal in cross section and intersecting at an angle Φ (fig.1.)

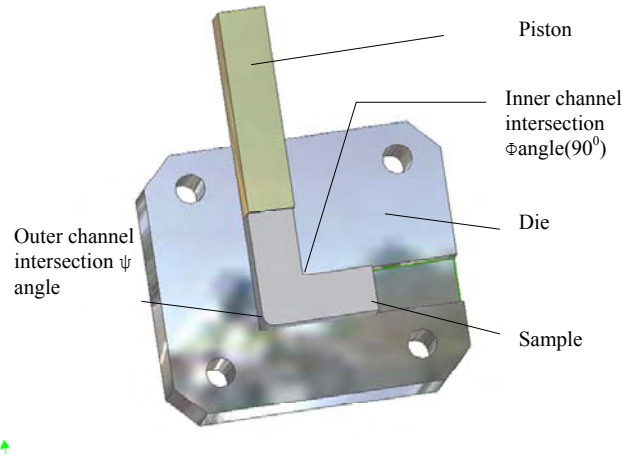

Fig.1 Equal channel extrusion dies

The billet undergoes essentially simple shear deformation but retains the same cross sectional geometry. The equal section in both channels makes possible multiple passes.

Repeated passes develop a very large deformation in bulk products. This process also leads to the formation of strong crystallographic texture in the material because a rotation of sample is possible [12](fig.2)

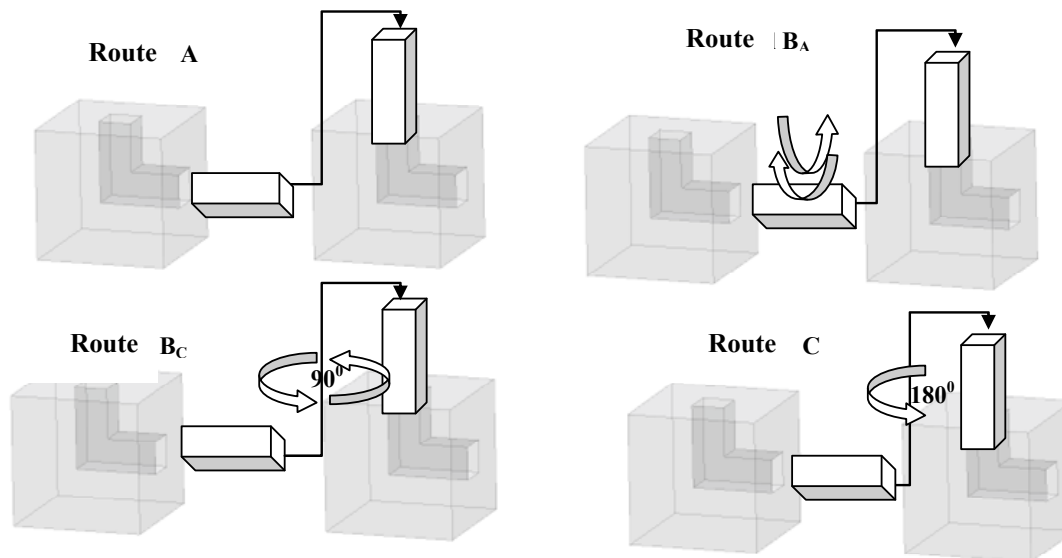

Fig.2 Different ECAE routes



The strain imposed on the sample in each deformation depend the angle Φ and also the angle Ψ , representing the outer arc of the curvature were two channels intersect (fig.3).

The corner angle Ψ is very important because the bigger the angle Ψ induce inhomogeneous metal [10] flow respectively inhomogeneous structure and properties (fig.4).

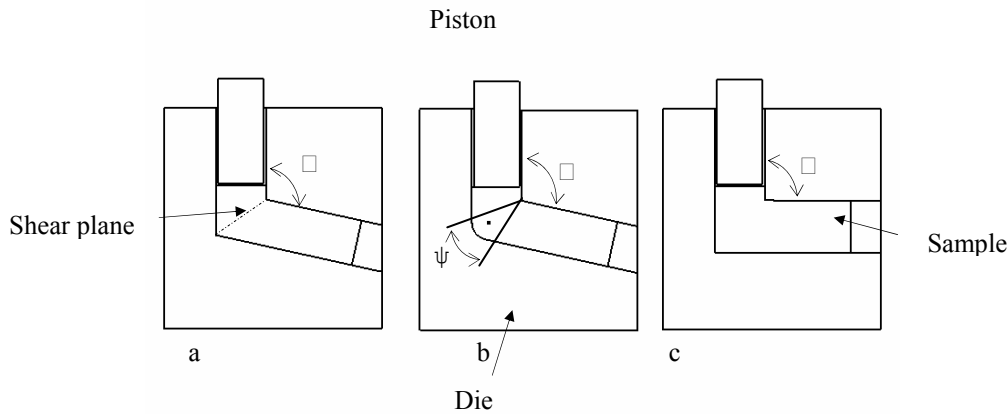

Fig.3. Schematic die with inner angle $\Phi > 90^\circ$, and outer angle $\Psi=0^\circ$ (a), $\Phi > 90^\circ$ and $\Psi > 0^\circ$ (b), $\Phi = 90^\circ$ and $\Psi=0^\circ$ (c). [10]

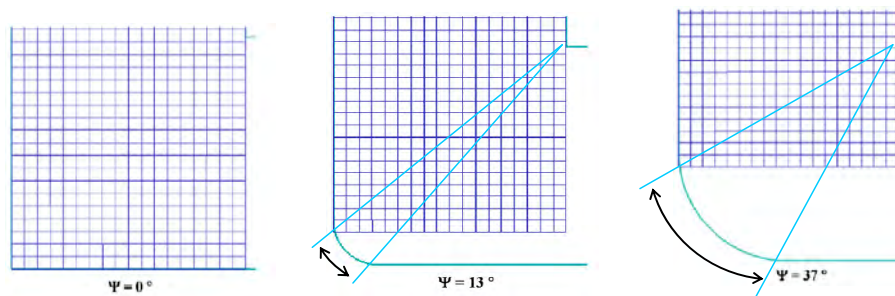

Fig.4. ECAE – various corner angles [10]

2. Experimental

2.1. A new conception ECAE device

In University of Galati, Plastic Deformation and Heat Treatment department a new ECAE device was developed. Based on scientific reports [9] these devices reduce significantly friction in the vertical channel. A Classic ECAE has four friction surfaces between device and sample. In the new method three friction surfaces was eliminated. The piston has a special form for supply the die with material without excessive friction force (fig. 5). Also in the section the piston has been eliminate the effort concentrators because a large radius was used.

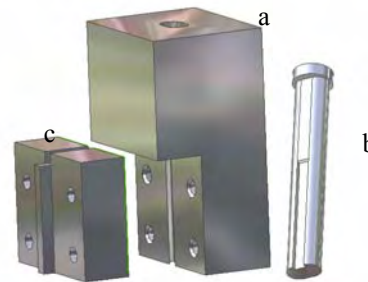

Fig.5. The parts of the new ECAE die a. piston, b. the die body, c. the die knife

2.2. A new method HPT

The HPT method involved a high pressure and a few rotations under this load. We developed a new HPT process for hard deformable materials. The news consist deformation at the high temperatures. This temperature is generated in system by friction at high piston rotations. All the process time pressure is action under piston. The HPT scheme is shown in figure 6.

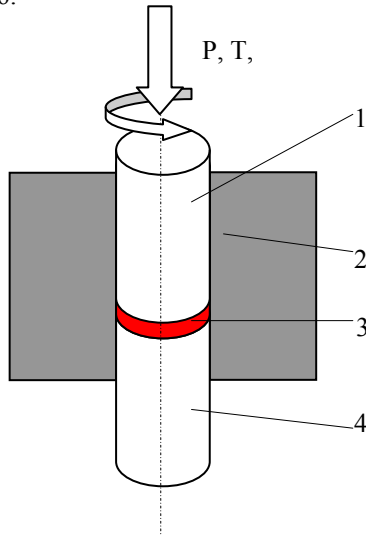

Fig. 6. HPT Scheme

1. revolving plunger, 2. container, 3. sample, 4. support plunger

3. Results and discussions

The new HPT method was applied on the shape memory alloy cooper based (Cu 12.88%wt Al 4%wt Ni). The samples used in severe deformation process were: hot extruded (Φ 4mm x 6 mm) and plates after ausforming (8mm x 8mm x 0.25mm). The structure of extruded samples was α , γ and pre martensitic forms with huge grains (fig. 7a.). The structure of plates after ausforming was typical γ' martensite (fig.7.b.).

After SPD HPT we obtained fine structures with nanometers grains size (fig.7.c)

4. Conclusions

- A new ECAE device was designed for reduce the processing force with reduce the friction between sample and die. Also the piston shape reduce the tensions concentrators.
- A new HPT method was developed and tested under hard deformable shape memory alloy.
- The nanostructure grain size was obtained.

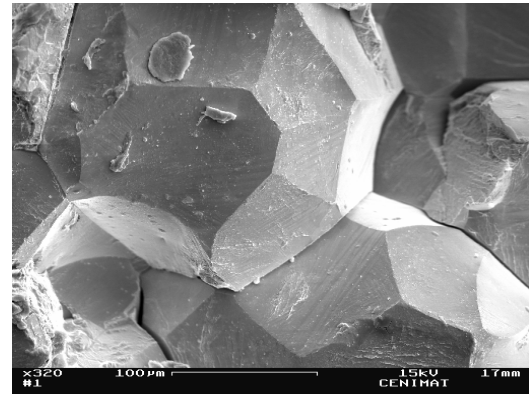

a

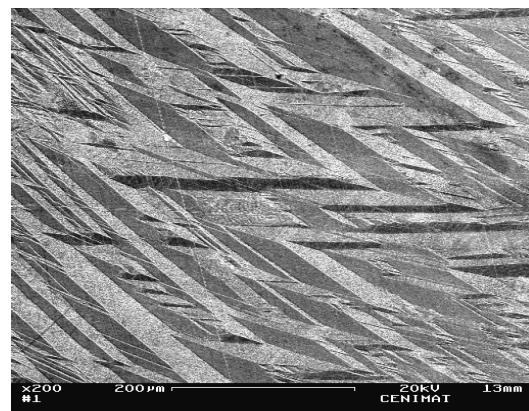

b



c

Fig.7. Shape memory alloy Cu 12.88%wt Al 4%wt Ni
a- hot extruded, b. quenched after hot rolling (asformed), c. nanostructured



5. References

- [1]. **K. Mueller a, S. Mueller b**, *Severe plastic deformation of the magnesium alloy AZ31* Journal of Materials Processing Technology 187–188 (2007) 775–779
- [2]. **J.G. Li, M. Umemoto, Y. Todaka, K. Tsuchiya**, *Role of strain gradient on the formation of nanocrystalline structure produced by severe plastic deformation*, Journal of Alloys and Compounds 434–435 (2007) 290–293
- [3]. **M. Hafoka, R. Pippana**, *Role of strain gradient on the formation of nanocrystalline structure produced by severe plastic deformation*, Scripta Materialia 56 (2007) 757–760
- [4]. **B. Kockar a, I. Karaman a*, A. Kulkarni a, Y. Chumlyakov b, I.V. Kireeva**, *Effect of severe ausforming via equal channel angular extrusion on the shape memory response of a NiTi alloy*, Journal of Nuclear Materials 361 (2007) 298–305
- [5]. **S. Swaminathan,a T.L. Brown,b S. Chandrasekar,b T.R. McNelleya,* and W.D. Compton**, *Severe plastic deformation of copper by machining: Microstructure refinement and nanostructure evolution with strain*, Scripta Materialia xxx (2007) xxx–xxx
- [6]. **M. Delince´ a, Y. Bre´chet b, J.D. Embury c, M.G.D. Geers d, P.J. Jacques a, T. Pardoen**, *Structure–property optimization of ultrafine-grained dual-phase steels using a microstructure-based strain hardening model*, Acta Materialia 55 (2007) 2337–2350
- [7]. **A. Mishra , B.K. Kad , F. Gregori , M.A. Meyers**, *Microstructural evolution in copper subjected to severe plastic deformation: Experiments and analysis*, Acta Mater 55 (2007) 13–28]
- [8]. **A. Concustell, J. Sort, S. Surinach, A. Gebert, J. Eckert, A.P. Zhilyaev, M.D. Baro´**, *Severe plastic deformation of a Ti-based nanocomposite alloy studied by nanoindentation*, Intermetallics xx (2007) 1e8
- [9]. **J.-P. Mathieu, S. Suwas, A. Eberhardt, L.S. T´oth , P. Moll**, *A new design for equal channel angular extrusion*, Journal of Materials Processing Technology 173 (2006) 29–33
- [10]. **S.C. Yoon, P. Quang, S.I. Hong, H.S. Kim**, *Die design for homogeneous plastic deformation during equal channel angular pressing*, Journal of Materials Processing Technology 187–188 (2007) 46–50
- [11]. **L. Kommel, I. Hussainova, O. Volobueva**, *Microstructure and properties development of copper during severe plastic deformation*, Materials and Design xxx (2006) xxx–xxx
- [12]. **Terence G. Langdon** *The principles of grain refinement in equal-channel angular pressing*, Materials Science and Engineering A xxx (2006) xxx–xxx