



**COGNITIVE AND OPERATIONAL
IMPLICATIONS OF
NON-HOMOGENEOUS AIRCRAFT
EQUIPAGE FOR AVIATION SYSTEM
TRANSFORMATION**

Patricia Pina
R. John Hansman

Report No. ICAT-2007-4
September 2007

***MIT International Center for Air Transportation
Department of Aeronautics & Astronautics
Massachusetts Institute of Technology
Cambridge, MA 02139 USA***

Cognitive and Operational Implications of Non-Homogeneous Aircraft Equipage for Aviation System Transformation

by

Patricia E. Pina

Submitted to the Department of Aeronautics and Astronautics
on August 23rd 2007, in partial fulfillment of the
requirements for the degree of
Master of Science in Aerospace Engineering

Abstract

The air traffic management system is currently experiencing a significant transformation to provide better quality service and to match the increasing air traffic demand. This transformation requires airlines to retrofit their fleet. However, airlines implement new operating capabilities at different rates resulting in long transition periods in which aircraft with different equipage levels coexist in the same airspace. Mixed equipage environments can increase controller workload and task complexity, limit the operational benefits of new operating capabilities, and deteriorate the overall system performance. This study proposes a three dimensional approach to explore mixed equipage effects: (1) understand cognitive implications for controllers, (2) understand operational implications for users, and (3) understand system level implications. To further investigate mixed equipage effects and to illustrate the proposed approach, this study analyzed the implementation of reduced separation standards in the North Atlantic.

An experimental analysis was conducted to study the integration of mixed separation standards. Results show significant human factor concerns. Controllers had higher error rates at very low mixed equipage levels. Results also suggest that a contributing causal factor may have been that participants employed inadequate system abstractions based on their current mental models. Airspace segregation based on equipage levels is recommended in the North Atlantic to alleviate controller cognitive limitations and ensure incentives for equipped aircraft. Segregation can facilitate the transition to reduced separation standards.

A preliminary estimation of the operational benefits that segregation could offer to equipped aircraft in the North Atlantic was performed. We developed a simplified model of the jet stream and its operational cost impact and contrasted the results with a statistical analysis of actual North Atlantic flight times. It was found that the model made optimistic predictions of flight time reduction. Based on the statistical analysis, the incentive for equipped aircraft in a segregated environment in the North Atlantic was estimated by a gain of 4 minutes. This figure is a preliminary estimation and further analysis with larger data samples is required to validate it.

Thesis Supervisor: R. John Hansman
Title: Professor of Aeronautics and Astronautics

Contents

1	<u>Introduction</u>	1
1.1	<u>Objective</u>	1
1.2	<u>Motivation</u>	1
1.3	<u>Methodology</u>	2
2	<u>Mixed Equipage and ATC Procedures</u>	4
2.1	<u>Mixed Equipage</u>	5
2.2	<u>Understanding Mixed Equipage Effects</u>	7
2.2.1	<u>Cognitive Implications of Mixed Equipage for Air Traffic Controllers</u>	9
2.2.2	<u>Equipage Value for Users</u>	10
2.2.3	<u>System Level Considerations</u>	11
2.3	<u>Conclusions</u>	13
3	<u>Cognitive Analysis of Mixed Equipage</u>	15
3.1	<u>Air Traffic Controller Cognitive Model</u>	15
3.2	<u>Implications of Mixed Equipage</u>	18
4	<u>Mitigating Mixed Equipage Implications</u>	22
4.1	<u>Ensuring Acceptability of Mixed Equipage ATC Procedures</u>	22
4.2	<u>Airspace Segregation</u>	26
4.3	<u>Preferential Treatment</u>	30
4.4	<u>Conclusions</u>	30
5	<u>North Atlantic (NAT) Operations</u>	33
5.1	<u>Air Traffic Control over the North Atlantic</u>	33
5.2	<u>North Atlantic Organized Track System</u>	35
5.3	<u>Separation Minima</u>	36
5.4	<u>Jet Stream</u>	38
5.4.1	<u>Modeling the Operational Cost Impact of the Jet Stream</u>	40
6	<u>Reduced Separation Standards in the NAT: Cognitive Considerations</u>	45
6.1	<u>30/30 Separation Minima</u>	45
6.2	<u>Air Traffic Controller Considerations: Experimental Studies</u>	47
6.2.1	<u>Experimental Design</u>	48
6.2.2	<u>Experimental Protocol</u>	53
6.2.3	<u>Results and Discussion</u>	53

6.3	Conclusions	58
7	Reduced Separation Standards in the NAT: Operational Implications	60
7.1	Operational Analysis of NAT Operations	60
7.1.1	Methods	61
7.1.2	Results	64
7.2	Conclusions	69
8	Reduced Separation Standards in the NAT: System Level Considerations	70
8.1	Methodology	70
8.2	Results	76
8.3	Conclusions	81
9	Conclusions	83
9.1	Mixed Equipage ATC Procedures	83
9.2	Segregation and Reduced Separation Standards in the NAT	84
10	References	85
Appendix A	Controller Errors: Chi-Square Test	88
Appendix B	Plots of Estimated Flight Time Means: Entrypoints and Entrytime	89
Appendix C	Bonferroni Contrasts of Flight Times	90
Appendix D	Static Segregation: Throughput vs. Equipage Rate	91
Appendix E	Dynamic Segregation: Throughput vs. Equipage Rate	92

List of Figures

Figure 2-1. Dual meaning of mixed equipage in the context of this thesis	5
Figure 2-2. System Transformation and Mixed Equipage	6
Figure 2-3. Example of cost and benefit distribution across stakeholders [5]	7
Figure 2-4. Risk of Mixed Equipage	8
Figure 2-5. Mixed Equipage potential effects on the user perceived value of new operating capabilities	11
Figure 2-6. ATM System Key Performance Areas from [6]	12
Figure 3-1. General Cognitive Model for Air Traffic Controllers	16
Figure 3-2. Mixed Equipage Implications on Controller’s Decision Making Model adapted from [13]	19
Figure 3-3. Mixed Equipage implication on Controllers’ General Cognitive Model	21
Figure 4-1. Acceptability of Mixed Equipage ATC Procedures	23
Figure 4-2. Ensuring Controller Acceptability	24
Figure 4-3. Ensuring User Acceptability	25
Figure 4-4. Ensuring Acceptability at the System Level	25
Figure 4-6. Airspace Segregation Decouples Mixed Equipage ATC Procedures	28
Figure 4-7. Potential Limits for Segregation	29
Figure 5-1. North Atlantic Flight Information Regions [21]	34
Figure 5-2. Very High Frequency Radio Coverage [21]	35
Figure 5-3. North Atlantic Eastbound Tracks on 4 May 2006	36
Figure 5-4. Current Separation Minima in the NAT OTS	37
Figure 5-5. Jet Stream on 17 March 2007 [27]	38
Figure 5-6. Jet Stream and Organized Track System on 17 March 2007 ([27], [28])	39
Figure 5-7. Jet Stream and Organized Track System on 20 March 2007 ([27], [28])	40
Figure 5-8. Horizontal wind speed (in % of maximum speed) for various profile classes [30]	41
Figure 5-9. Example of eastbound tracks and average wind speed reduction per track ..	42
Figure 5-10. Parametric representation of extra operating cost as flights move away from the jet core	44

Figure 6-1. 30/30 Separation vs. Current Separation in the NAT OTS	47
Figure 6-2. The ATC oceanic simulation environment	49
Figure 6-3. Separation requirements for the non-equipped aircraft	50
Figure 6-4. Separation requirements for the non-equipped aircraft	50
Figure 6-5. Separation requirements for one non-equipped and one equipped aircraft ...	51
Figure 6-6. Spatial scale	53
Figure 6-7. Total conflicts undetected vs. percentage of equipped aircraft	54
Figure 6-8. Total commission errors vs. percentage of equipped aircraft	54
Figure 6-9. Total omission errors vs. aircraft involved in conflict	55
Figure 6-10. Total commission errors vs. aircraft involved in conflict	56
Figure 6-11. Time-to-task completion and Perceived level of difficulty	57
Figure 6-12. Factors affecting scenario difficulty as reported by air traffic controllers ...	58
Figure 7-1. Jet Stream over the NAT on 8 December 2006 [27]	61
Figure 7-2. Entry points in the NAT and. Radar Data on 8 December 06	62
Figure 7-3. Distribution of aircraft type for eastbound traffic on 8 December 2006	63
Figure 7-4. Aircraft type categorization based on cruise speeds	63
Figure 7-5. Histogram of the entering time in the NAT for eastbound traffic on 8 December 2006	64
Figure 7-6. Boxplot of flight time vs. Entry point, Entry time, and Aircraft Type	65
Figure 7-7. Mean flight times between 2-4am & 4-6am vs. Entry point	66
Figure 7-8. Mean Flight Time Differences: Actual Fight Data vs. Simplified Model	67
Figure 7-9. Track utilization between 2-4am & 4-6am	68
Figure 8-1. NAT Eastbound tracks & Flight Levels	71
Figure 8-2. Example of Static Segregation. Maximum Throughput as a Function of % Equipped Aircraft	73
Figure 8-3. Example of Dynamic Segregation. Maximum Throughput as a Function of % of Equipped Aircraft	74
Figure 8-4. Example of Segregation Rules to Maximize Throughput	75
Figure 8-5. Segregation Rules to implement 30NM Longitudinal Separation in the NAT	77

[Figure 8-6. Reduction of lateral separation minima enables new tracks to be added to the NAT OTS.....](#) 77

[Figure 8-7. Segregation Rules to implement 30NM Lateral Separation in the NAT](#) 78

[Figure 8-8. Segregation Rules to implement 50NM Longitudinal Separation in the NAT](#) 80

[Figure 8-9. Example of Segregation Rules in case of complex separation standards](#) 81

List of Tables

Table 4-1. Example of Potential Strategies to Combat Mixed Equipage Implications	32
Table 6-1. Total number of existing conflicts vs. aircraft equipage levels per participant	55
Table 7-1. Results from the 4x2x3 ANOVA model	65
Table 7-2 Mean Flight Time Differences per Entry Point and Entry Time (all aircraft categories)	67

1 Introduction

1.1 Objective

The aviation system is currently undergoing a process of significant transformation to meet the increasing traffic demand and users' requests. As a result, a variety of new decision-support tools and technologies for communication, surveillance, and navigation are available. This diversity and the different rates at which air navigation service providers and airlines are implementing these new operating capabilities have resulted in non-homogeneous (mixed) aircraft equipage levels.

Mixed equipage can pose barriers to air traffic management system transformation. Excessive cognitive complexity for controllers and limited user operational benefits are examples of potential negative consequences of mixed equipage.

The goal of this thesis is to explore and better understand mixed equipage and its implications for the controller, the user, and the system. In addition, this thesis aims at identifying potential mechanisms that can be used to mitigate adverse mixed equipage effects.

1.2 Motivation

The aviation community in the USA and Europe is working in the definition of the future air traffic management system. The Next Generation Air Transportation System in the USA and SESAR in Europe are innovative concepts of operation that require a complete revolution of the current system. Advanced procedures such as self-separation

or four dimensional trajectory management are expected to constitute the core of these future systems.

Such a transformation will not occur easily or quickly. The need to accommodate mixed capability aircraft is recognized in both programs and efforts are devoted to investigate how to integrate mixed equipage aircraft during system transition.

However, existing research on mixed equipage has focused on evaluating controller performance in mixed equipage environments. Little effort has been directed to formally understand mixed equipage implications for controllers, airlines, and the overall system performance. Better understanding of mixed equipage implications is essential to successfully resolve the integration of aircraft with mixed operating capabilities.

1.3 Methodology

The methodology used in this thesis is based on an integrated human centered systems approach which combines traditional human factors techniques with those used in systems engineering.

The proposed approach to mixed equipage is introduced in Chapter 2. This thesis proposes a threefold approach to mixed equipage: (1) understand overall system implications, (2) understand implications for controllers, and (3) understand implications for users. Mixed equipage can affect both the overall system performance and the individual elements that compose the system. In this thesis, air traffic controllers and airlines are considered the two main system elements affected by mixed equipage. In addition, Chapter 2 introduces the concept of mixed equipage in the context of the thesis.

Mixed equipage refers to both the technical equipment as well as the operational procedures; both are key elements to understand mixed equipage implications.

Chapter 3 explores the cognitive implications of mixed equipage for air traffic controllers, proposing a general cognitive model that can help understanding mixed equipage. Based on the analysis of mixed equipage implications, Chapter 4 investigates potential mechanisms to mitigate mixed equipage effects. Finally, Chapters 5 to 8 discuss the implementation of reduced separation standards in the North Atlantic as an example to illustrate the mixed equipage considerations discussed in previous chapters.

2 Mixed Equipage and ATC Procedures

In aviation, the operational implementation of new Communication, Navigation, Surveillance, and Air Traffic Management (CNS/ATM) capabilities is a complex and lengthy process. Conflicting goals and differences in the implementation timeframe of stakeholders slow down system transformation. For example, Hollinger and Narkus-Kramer consider reasonable to project a transition period of 16 year before planned improvements such as RNP routes, ADS-B/CDTI procedures and data link capabilities linked to automation changes on the ground are fully implemented in the National Airspace System (NAS) [1].

This chapter discusses implications for the Air Traffic Management (ATM) system of having long transition periods where aircraft with different operating capabilities coexist. A multi-level approach is selected in this thesis to investigate both aggregate and individual effects of mixed equipage.

The next section defines “mixed equipage”. Then the importance of considering both system and individual stakeholder perspectives is discussed. Finally, the implications of mixed equipage for controllers, users, and at the system level are explored.

2.1 Mixed Equipage

Mixed equipage refers to the coexistence of aircraft with various equipments and capabilities subject to different operating procedures. In the context of this thesis, mixed equipage comprises both mixed technical equipment, which enables different operating capabilities, and mixed air traffic control (ATC) procedures. Figure 2-1 illustrates this dual meaning of mixed equipage.

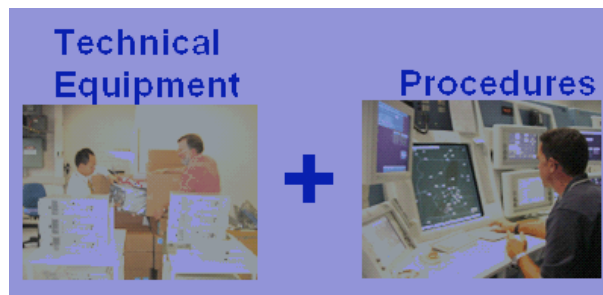

Figure 2-1. Dual meaning of mixed equipage in the context of this thesis

Figure 2-2 represents three phases of system transformation. In the “early adopter” phase, very few aircraft are equipped with the new operating capability and controllers primarily employ the same ATC procedures for all aircraft. As the new operating capability is more widely adopted, an actual mixed equipage environment arises. In the “partially equipped” phase, ATC procedures are contingent on the situation and the equipment. Finally, during the “exception” phase, most aircraft are equipped with the new operating capability and controllers mainly apply the same procedure for all aircraft again.

In the early adopter and exception phases, most aircraft are subject to the same procedures. The few aircraft that are equipped with different capabilities cause small disruptions in controllers’ tasks and system performance. However, during the partially

equipped phase, discriminating aircraft capabilities and appropriate procedures becomes part of controllers' routine tasks. Mixed equipage is reported in the existing literature to have adverse consequences on controller' situation awareness and workload, and requires special consideration ([2], [3], [4]).

As illustrated in Figure 2-2, system inefficiencies drive system transformations, but the full system benefits are not achieved until the transition ends. During the transition, mixed equipage limits the operational benefits derived from the new operating capability. These potential negative effects of mixed equipage can endure for years and motivate the need for exploring and better understanding mixed equipage. Understanding and developing a plan for both the transition period and the final state of the system transformation helps guaranteeing the success of the transformation.

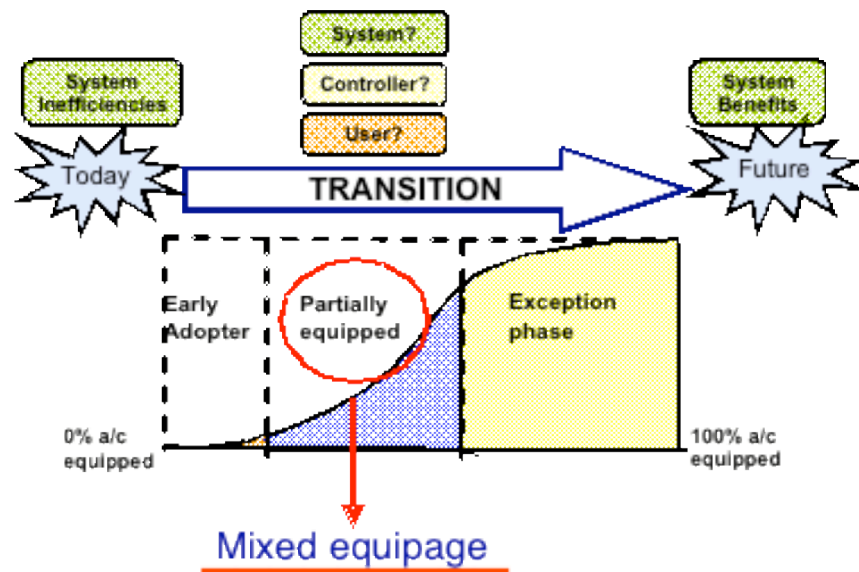

Figure 2-2. System Transformation and Mixed Equipage

2.2 Understanding Mixed Equipage Effects

As pointed out by Marais and Weigel, a new operating capability that may show an overall positive value can nevertheless fail to provide value to individual stakeholders [5]. Some stakeholders may reap a disproportionate share of the benefits, while others may incur a disproportionate share of the costs. Figure 2-3, from Marais and Weigel work, illustrates such a situation. Filled-in circles in the figure indicate that a particular stakeholder derives a particular benefit, or incurs a particular cost. In this example, the first stakeholder (stk1) reaps the majority of benefits, and the nth stakeholder (stkn) bears the majority of the costs.

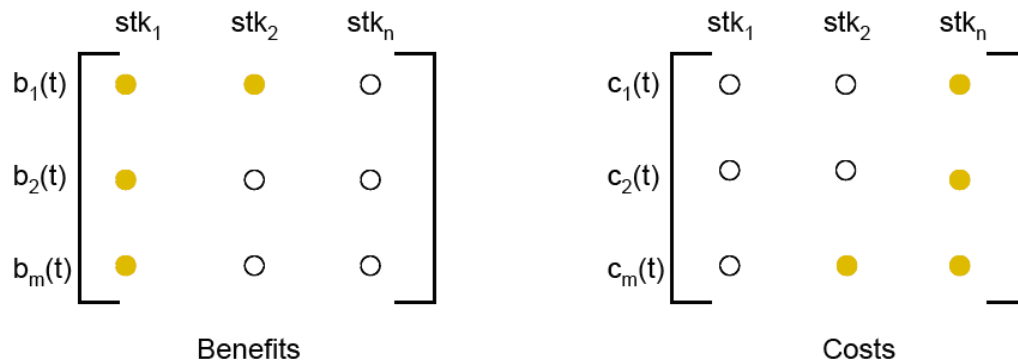

Figure 2-3. Example of cost and benefit distribution across stakeholders [5]

Stakeholders that incur large costs but get little benefits have no incentive or motivation to adopt the new operating capability. In the example of Figure 2-3, the nth stakeholder would oppose to the change as the value for him is negative. The framework proposed by Marais and Weigel to study technology transition can be used to study and understand mixed equipage effects.

For a successful system transformation, a positive value at the final state of the transformation for the aggregate system and for the individual stakeholders is necessary

but not sufficient. The temporal distribution of value throughout the transition period also affects stakeholders' decisions, and therefore the success of the transformation.

Mixed equipage can impact value distribution at different levels during the transition, as illustrated in Figure 2-4. For example, Major and Hansman suggest that controllers tend to resolve conflicts in mixed equipage environments by maneuvering the aircraft with the higher operating capabilities [4]. This creates penalties for the users equipped since they are more often deviated from their routes. Furthermore, some operating capabilities such as ADS-B require multiple aircraft to be equipped to provide operational benefits. Potential penalties for equipped aircraft as well as the fact that users might not get the expected benefits because of low equipage levels, create resistance on users to system transformation.

In addition, mixed procedures can create additional complexity for controllers. At an aggregate level, this increase in complexity can adversely affect system performance areas such as capacity or safety.

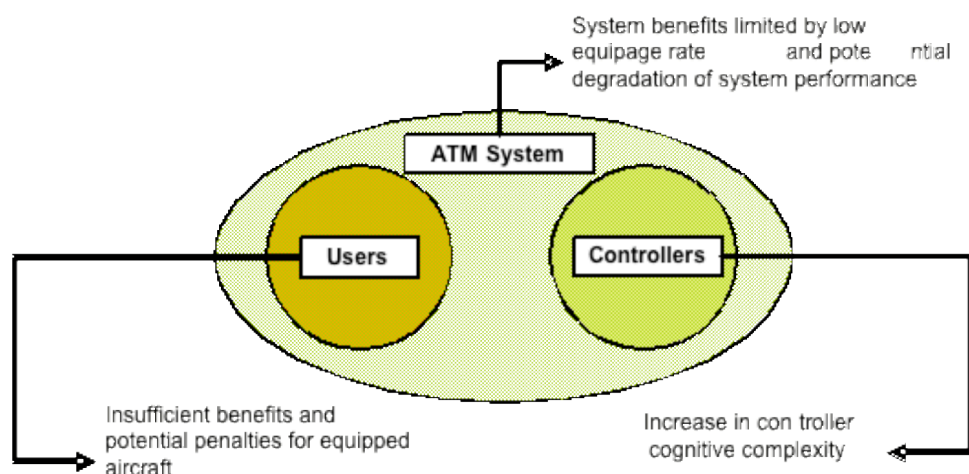

Figure 2-4. Risk of Mixed Equipage

Studying the implications of mixed equipage for the system and for each stakeholder can reveal value imbalances and help identify appropriate leverage strategies for system transformation. In order to illustrate the application of this approach, two main stakeholders are chosen: air traffic controllers and commercial airlines as users. Depending on the goal of the study, other stakeholders such as general aviation, regulatory bodies, or the general public might also have to be considered.

2.2.1 Cognitive Implications of Mixed Equipage for Air Traffic Controllers

Plentiful examples of adverse repercussion on air traffic controllers due to mixed equipage are found in the existing literature. CASCADE's human-in-the-loop experiments on datalink showed that the mixed environment (coexistence of datalink and non-datalink equipped aircraft) was the main factor of workload for controllers [2]. It was very demanding and stressful to distinguish aircraft capabilities and to make the correct input. Other human-in-the-loop experiments have also led to similar conclusions. In a FAA operational evaluation of pilot self-spacing, controllers rated mixed equipage scenarios as confusing and operationally unacceptable [3]. In this experiment, the main reason argued was also the need to determine the equipage for each aircraft and make traffic calls differentially. Additional evidence can be found in a simulation on mixed separation standards in oceanic airspace conducted at MIT. Results suggest that integrating multiple levels of equipage has negative implications for controller situation awareness and task difficulty [4].

Although several experimental studies on mixed equipage have been conducted there is little formal research on understanding its effects on controllers' cognitive processes.

Chapter 3 of this thesis is devoted to investigate the cognitive implications of mixed equipage for controllers. It proposes a controller cognitive model and discusses and explores mixed equipage using this model.

2.2.2 Equipage Value for Users

Users are reluctant to retrofit aircraft with new operating capabilities because they incur large costs (e.g. acquisition cost, certification cost) but often do not reap sufficient benefits. In particular, throughout transition periods, potential benefits derived from new operating capabilities might not be achieved. There are three main adverse effects of mixed equipage which can impact the value offered by a new operating capability to users.

First, mixed equipage can result in tailoring operations to the least capable user, preventing aircraft equipped with higher levels of capabilities from getting the expected benefits. Second, as found by Major and Hansman, controllers sometimes penalize higher equipped aircraft, deviating them from their routes, in order to mitigate the increase of cognitive complexity due to mixed equipage [4]. Third, for some technologies such as ADS-B, the expected benefits may not occur if the number of equipped aircraft is small. Figure 2-5 illustrates these features.

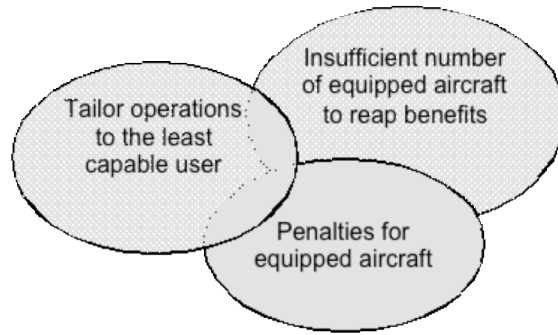

Figure 2-5. Mixed Equipage potential effects on the user perceived value of new operating capabilities

Since transitions in aviation occur over long periods, it is essential to establish mechanisms that encourage airlines to equip their aircraft with new operating capabilities. Creating added value for the early adopters makes retrofitting more attractive and can contribute to accelerating transitions.

2.2.3 System Level Considerations

In addition to controller and user implications, mixed equipage might also have aggregate effects on the air traffic management (ATM) system. This study employs the SESAR program’s understanding of the ATM system performance to discuss these system level considerations.

SESAR represents the ATM performance through 11 Key Performance Areas (KPA) which can be clustered into three major groups: “Societal Outcome”, “Operational Performance”, and “Performance Enablers” [6]. The grouping criteria are based on the KPA outcome and impact, rather than on how the performance is achieved.

The KPA group “Societal outcome” refers to Safety, Security, and Environmental Management and Control. Their effects are of a political nature and are even visible to

those who are not users of the air transportation system. The KPA group “Operational Performance” comprises areas that directly describe the operational performance and associated costs of airspace users, airport operators, and air navigation service providers: Cost-Effectiveness, Capacity, Efficiency, Flexibility, and Predictability. The visibility of its effects generally does not go beyond airspace user customers (e.g. passengers). The KPA group “Performance Enablers” consists of the performance of enabling activities and processes rather than that of operational outcomes. This group comprises the following areas: Access and Equity, Participation by the ATM Community, and Interoperability. This group is not of direct interest to airspace user customers. Figure 2-6 illustrates the three clusters and the 11 KPAs.



Figure 2-6. ATM System Key Performance Areas from [6]

KPAs are interdependent and can be used for impact assessment of new operating capabilities and consequent trade-off analysis for decision making. Mixed equipage can also be discussed under this framework.

Mixed equipage can potentially affect some of these system performance areas limiting the system benefits expected from the new operating capabilities. The increase of cognitive complexity for controllers due to mixed equipage can potentially increase the likelihood of controller errors, and therefore deteriorate system safety. In addition,

controllers might sometimes try to reduce their complexity levels by imposing additional system constraints in order to limit the number of aircraft and flight deviations from their original plans. Such behavior can negatively affect system capacity and flexibility. As discussed previously, mixed equipage can also lead to penalties for aircraft equipped with higher capability levels. Penalties are contrary to the objective of ensuring equity for all airspace users.

Consequences of these effects differ depending on the cluster being affected. For example, safety implications might affect the general public perception of the air transportation system, while flexibility implications might affect only passenger perception. Additional positive value needs to be generated at the same level of system visibility as the one being negatively affected to counteract mixed equipage implications. As mentioned, KPAs are interdependent and their conflicting objectives might require trade-offs. For example, the objective of providing flight trajectories closer to user preferred trajectories may have to be balanced against the objective of increasing capacity.

2.3 Conclusions

The majority of the studies on new operating capabilities are conducted under the assumption that all aircraft are equipped. The few studies that incorporate mixed equipage issues suggest that problems may arise under this condition. For example, the FAA report that summarizes the existing literature on workload and performance issues related to pilot-based spacing concludes that concerns with self-spacing in mixed equipage environments still exist [7]. It also recommends additional studies to

investigate the viability of these concepts under a range of operational conditions that include mixed equipage.

The aviation community recognizes the existence of risks and challenges associated with mixed equipage but little effort has been devoted to formally understand its implications and to develop an appropriate framework to investigate it. The method proposed in this chapter analyzes mixed equipage from three different perspectives: implications at the controller level, at the user level, and at the system level. On the controller side, mixed equipage might potentially modify the nature and the complexity of cognitive processes. From the user perspective, mixed equipage might limit the attractiveness of investing in new operating capabilities. At the system level, mixed equipage might have repercussions on key performance areas such as safety, capacity, or flexibility.

3 Cognitive Analysis of Mixed Equipage

This chapter explores the cognitive implications of mixed equipage for controllers. Most of the existing research on human factor concerns due to mixed equipage has focused on evaluating controller performance rather than understanding controller cognitive processes. As a result, there is not yet a controller cognitive model that explains mixed equipage effects. This chapter proposes a generic cognitive model and uses it to discuss mixed equipage from the controller perspective.

3.1 Air Traffic Controller Cognitive Model

Figure 3-1 illustrates the general cognitive model for air traffic controllers proposed in this thesis. This model is partly based on the work conducted by Pawlak et al. [8], Endsley and Garland [9], and Major and Hansman [4].

The cognitive model consists of three differentiated, but interrelated layers. The main air traffic control (ATC) tasks constitute the lower layer in Figure 3-1. This layer combines physical and mental tasks or processes that controllers perform as part of their duties. The second layer refers to the situation awareness or situation picture that controllers develop to conduct ATC tasks. The third layer is related to the controllers' mental model and system abstractions, which form the underlying knowledge and the basis to create the situation awareness.

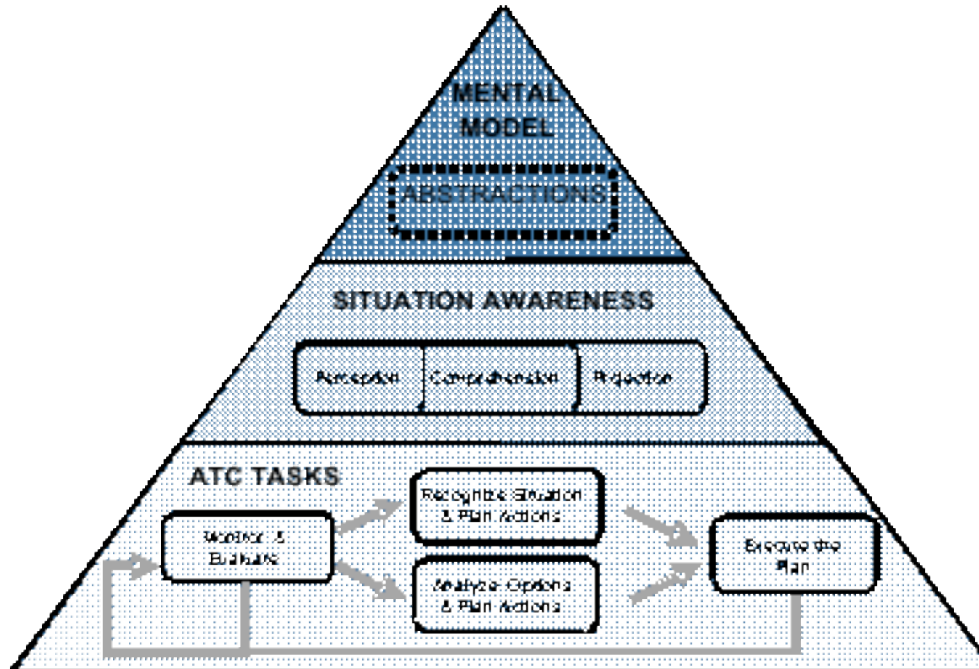

Figure 3-1. General Cognitive Model for Air Traffic Controllers

The goal of the controller is to manage air traffic, adjusting its evolution to the system constraints (e.g. handoffs altitudes, separation minima, convective weather) and resolving conflicts between aircraft. Pawlak et al. [8] decompose air traffic control into four main processes or tasks: monitoring, evaluation, planning, and implementation.

The monitoring and evaluation processes drive controller decision on whether to intervene. In the planning process, controllers determine the best course of action needed and develop a plan. This process can be executed in two different ways depending on the expertise and experience of the controller: (1) controller identifies the applicable control actions, evaluates their impact, and chooses the best one or (2) controller recognizes the situation and evokes an appropriate action as Klein and Klinger describe in their Recognition-Primed Decision model (RPD) [10]. Klein and Klinger argue that decision making in complex environments under time pressure seems to be “induced by a starting

point that involves recognition matches that in turn evoke generation of the most likely action”. After the plan is built, it must be implemented, monitored, and evaluated.

This model is complementary to Klein’s RPD model. Klein proposes that in dynamic environments under time pressure experienced decision makers select, based on their previous knowledge, the most plausible action for reaching their goal, given the constraints of the situation. His work suggests that decision makers devote much effort to figuring out the nature of the problem, which corresponds to the monitoring and evaluation tasks of the general cognitive model shown in Figure 3-1. Klein also suggests that single candidate course of actions are evaluated sequentially through mental simulation of outcomes and options are accepted if they are satisfactory rather than optimal, which corresponds to the planning tasks of our model.

As illustrated in Figure 3-1, controller tasks and decision making process constitute a close-loop control mechanism. Each of these four main processes or tasks is continuously performed for each aircraft at different times and may stimulate the initiation of another process.

The second layer refers to operator situation awareness (SA), which is defined by Endsley as “the perception of the elements in the environment within a volume of time and space, the comprehension of their meaning and the projection of their status in the near future” [9]. Understanding the current air traffic situation and its future evolution is essential to make correct decisions and control air traffic efficiently and safely. SA is the main precursor to decision making and is closely related to the monitoring and evaluation tasks of the first layer.

Mental models and cognitive strategies compose the third layer. They refer to organized sets of knowledge about the system operated and the environment, and they are acquired with experience. Rouse and Morris define mental models as “the mechanisms whereby humans are able to generate descriptions of system purpose and form, explanations of system functioning and observed system states, and predictions of future system states [11].” The mental model structures the data held in SA and directs attention.

The information included in the mental model and its level of detail vary depending on the operators’ experience and the tasks to be conducted. People think about complex systems at different levels of abstraction to perform different tasks [12]. The higher the level of abstraction at which a person thinks about the system, the fewer the elements there are to think about, and the lower the mental workload and the amount of data to carry in the working memory.

3.2 Implications of Mixed Equipage

Mixed equipage introduces a new factor in controllers’ tasks and decision making: equipage levels determine the applicable rules and criteria. To better understand the effect of mixed equipage at the task level, the general cognitive model presented in the previous section is discussed in combination with Klein’s RPD decision making model [13].

The effect of mixed equipage on the lower layer of the cognitive model is threefold. First, controllers have a new state to keep track of: equipage level. Second, since the applicable rules or criteria depend on the equipage level, controllers have to handle

dynamic system rules and criteria when evaluating whether plausible actions and their consequences are acceptable or not. Finally, the task of projecting forward the likely consequences of candidate actions can also be altered. If aircraft behavior depends on its technical equipment, controllers need to choose and employ the right dynamics for each aircraft when mentally simulating its future evolution. Figure 3-2 illustrates these implications.

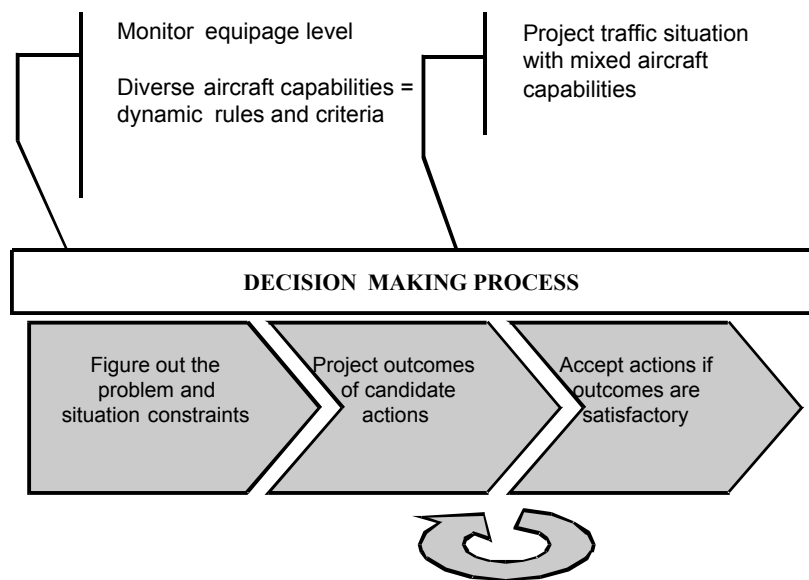

Figure 3-2. Mixed Equipage Implications on Controller’s Decision Making Model adapted from [13]

Situation awareness constitutes the second layer of the cognitive model and the basis for decision making. Mixed equipage requires controllers to monitor aircraft capabilities as well as to understand their implications on ATC procedures and traffic evolution. This new cognitive process adds complexity to controllers’ role. Previous studies on mixed equipage have shown that building and maintaining good situation awareness in mixed equipage environments requires high mental efforts. For example, during a simulation

study on data link conducted by Eurocontrol, controllers reported that the most demanding task was to understand the situation with mixed equipage [2]. If aircraft with different capabilities require distinct ATC procedures, building and maintaining situation awareness is more complex for controllers.

Additional evidence for this is found in the human-in-the-loop experiments conducted by Eurocontrol to study mixed Airborne Separation Assistance System (ASAS)¹ and non-ASAS equipage² [14]. These simulations showed that standard vectoring was no longer compatible with ASAS procedures. Controllers reported a risk of forgetting to assign speed on the final approach segment for non-equipped aircraft because they did not have to report this speed for ASAS equipped aircraft. Harmonizing the criteria or rules applicable to the equipped and non-equipped aircraft makes it easier for controllers to maintain good situation awareness and helps them handling mixed equipage.

At the higher level of the cognitive model, mixed equipage requires controllers to incorporate aircraft capabilities into their mental models as well as mixed equipage ATC procedures dependent on these aircraft capabilities.

Another effect at this level of the model is the potential need for developing new abstractions of the system that efficiently support the ATC tasks in mixed equipage environments. As pointed out by Mogford, given the heavy cognitive demands of ATC, controllers often do not retain all the available information but instead they develop a

¹ ASAS refers to an aircraft system based on airborne surveillance that provides assistance to the flight crew supporting the separation of their aircraft from other aircraft.

² The proportion of equipped aircraft was on average about 50%. All aircraft were equipped to be target (ADS-B out).

system abstraction to retain critical information that will improve their performance of high-priority tasks [15]. Controllers develop, during their training, abstractions and mental models applicable for environments where most aircraft share the same capabilities. These abstractions might not be useful when mixed equipage is introduced and new ways to think of and abstract the system might have to be developed.

Figure 3-3 summarizes the discussion on the effects of mixed equipage on controllers' general cognitive model.

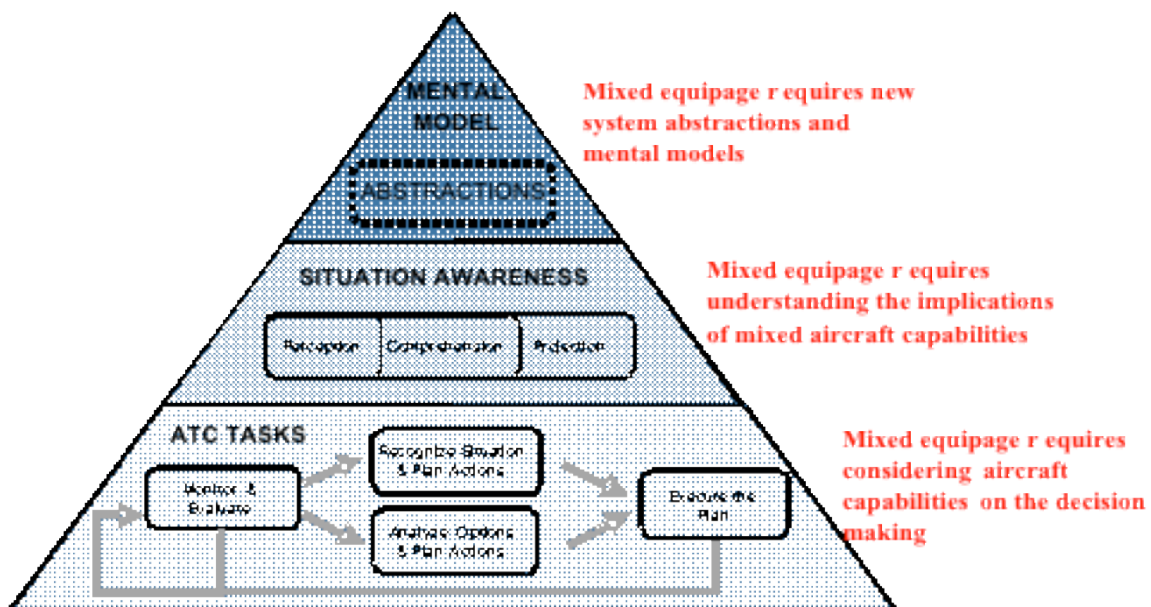

Figure 3-3. Mixed Equipage implication on Controllers' General Cognitive Model

4 Mitigating Mixed Equipage Implications

As discussed in Chapter 2, system transformation in aviation can lead to mixed equipage conditions, which creates barriers and risks that can slow down the transformation. The challenge for the ATM community is to design and implement mixed equipage ATC procedures that combat potential negative implications of mixed equipage and thereby accelerate transitions.

This chapter explores potential mechanisms that could combat mixed equipage concerns and identifies generic considerations for the design of mixed equipage ATC procedures. In particular, it suggests basic principles that could facilitate controller and user acceptability of these procedures without compromising system performance. In addition, airspace segregation and preferential treatment, examples of potential mechanisms to facilitate transitions, will be discussed.

4.1 Ensuring Acceptability of Mixed Equipage ATC Procedures

If mixed equipage ATC procedures can be developed to benefit the overall ATM system as well as each stakeholder, some of the transition barriers mentioned in Chapter 2 would be reduced. Benefits drive acceptability, so the ATM community would be more willing to tolerate mixed equipage. In particular, as illustrated in Figure 4-1, successful transition requires ATC procedures for mixed equipage that: (1) maintain controller cognitive complexity at acceptable levels; (2) provide benefits which encourage users to equip their fleet; and (3) improve overall system performance.

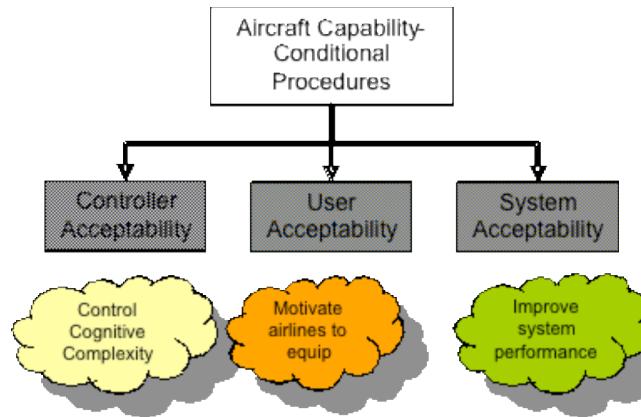

Figure 4-1. Acceptability of Mixed Equipage ATC Procedures

From the controller perspective, mixed equipage ATC procedures do not provide any direct benefit per se but impose costs in terms of cognitive complexity and workload. Controllers would be opposed to any change that creates costs but not benefits. In order to minimize controller opposition to the introduction of new operating capabilities, the increase of cognitive complexity due to mixed equipage should be minimized. Such an approach may require modifying the ATC procedures, ATC tasks, or ATC technical systems.

The cognitive model presented in Chapter 3 can help to identify basic design principles for mixed equipage ATC procedures. As shown in Figure 4-2, mixed equipage procedures can affect controller cognitive complexity at three different levels: task complexity and decision making, situation awareness, and mental models. Mechanisms used to reduce controller cognitive complexity generally impact more than one of these levels. For example, segregation of operations with different airspace regions allocated to aircraft with different operating capabilities makes it easier to build and maintain situation awareness but also affects controller mental models as will be explained later in

this chapter. Delegating separation responsibility to pilots changes the nature of ATC tasks and potentially simplifies them, but it also might have implications for the mental model and cognitive abstractions.

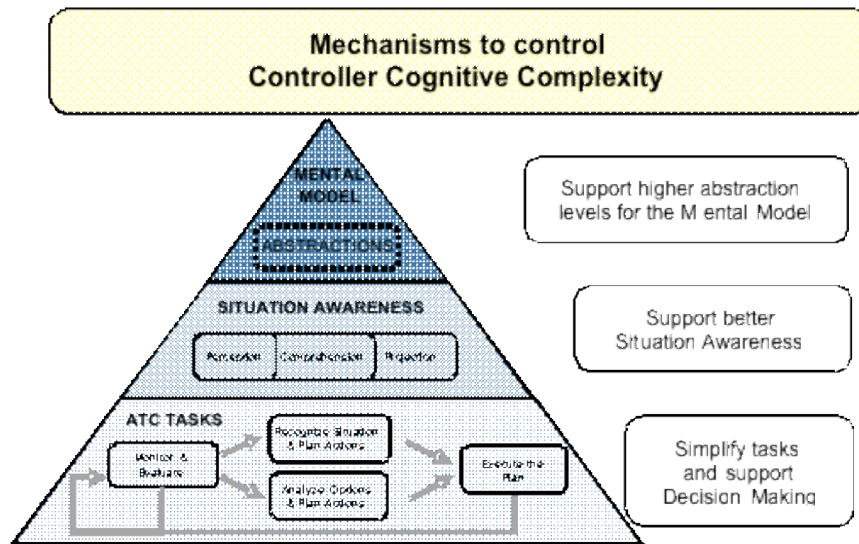

Figure 4-2. Ensuring Controller Acceptability

If mixed equipage ATC procedures provided attractive benefits for the aircraft equipped with higher operating capabilities, they could also incentivize more rapid equipment. As illustrated in Figure 4-3, these benefits could be monetary, e.g. fee reduction, or operational, e.g. preferential access to high-demand airspace, which has strategic economical value.

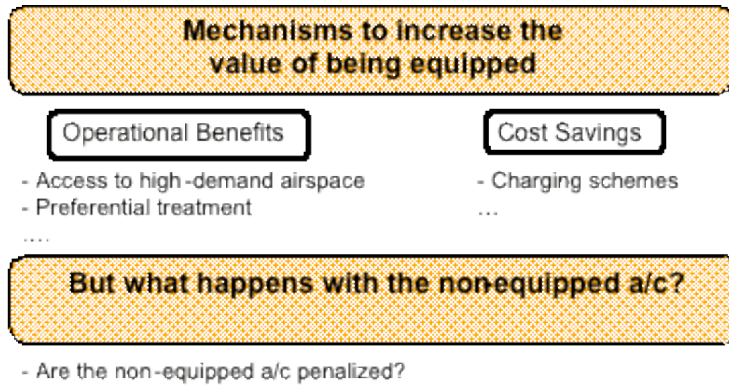

Figure 4-3. Ensuring User Acceptability

Finally, as illustrated in Figure 4-4, mixed equipage ATC procedures should also increase or at least maintain the overall system value for the key performance areas mentioned in Chapter 2.: safety, security, environmental sustainability, cost effectiveness, capacity, efficiency, flexibility, predictability, access and equity, participation, and interoperability.

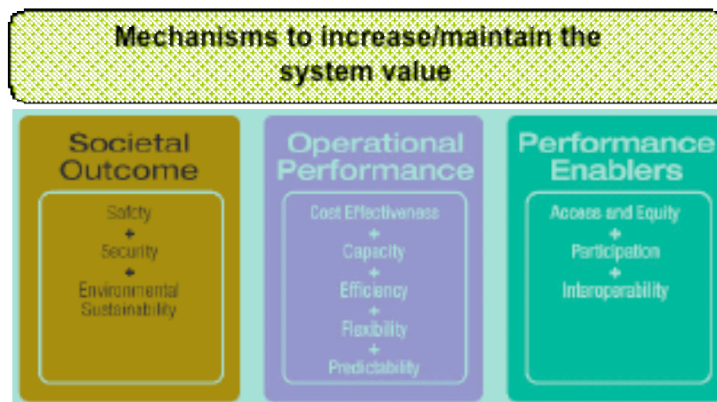



Figure 4-4. Ensuring Acceptability at the System Level

4.2 Airspace Segregation

Airspace segregation is an example of an approach that could potentially alleviate mixed equipage implications. The implementation of mixed equipage ATC procedures based on airspace segregation could mitigate cognitive complexity for controllers and incentivize equipage adoption among users. Segregation refers to the separation of aircraft equipped with higher operating capabilities from other less equipped traffic. Aircraft can be separated based on different airspace assets such as routes or flight levels. In addition, segregation can be statically or dynamically implemented as shown in Figures 4-5a-c. In these examples, airspace segregation is based on route structure. In Figure 4-5a the airspace is unsegregated and the aircraft equipped with higher and lower operating capabilities are randomly distributed among routes. Figure 4-5b shows static segregation; the middle route is always devoted to those aircraft equipped with higher capabilities. Dynamic segregation is illustrated in Figure 4-5c. In this example, the route on the top is temporarily dedicated to the aircraft equipped with higher capabilities. When the number of equipped aircraft or the demand for that particular route decreases, the aircraft with lower capabilities are reassigned to that route.

-  Equipped with higher operating capabilities
-  Equipped with lower operating capabilities

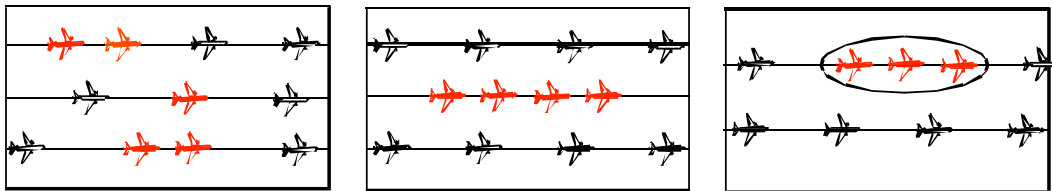

Fig. 4-5a. No Segregation Fig. 4-5b. Static Segregation Fig. 4-5c. Dynamic Segregation

Segregation has the potential to mitigate the increase in controller cognitive complexity inherent to mixed equipage. As discussed in Chapter 3, building and maintaining good situation awareness in mixed equipage environments is one of the biggest challenges for controllers. The use of separate and unique locations associated with particular equipment attributes helps controllers to better remember and track aircraft operating capabilities.

As discussed by Wickens and Holland, using separate locations for objects with different attributes reduces interference between information [16]. Moreover, Wickens and Holland recommend the use of this principle even when the information is available on a display. Spatial dissociation eases the process of perception through top-down processing.

Besides improving situation awareness, airspace segregation also enables decoupling mixed equipage procedures. As illustrated in Figure 4-6, controllers can now divide the control problem of mixed equipage traffic into two simpler problems: (1) control of the traffic equipped with higher operating capabilities in one physical location, and (2) control of the traffic equipped with lower operating capabilities in a different physical location.

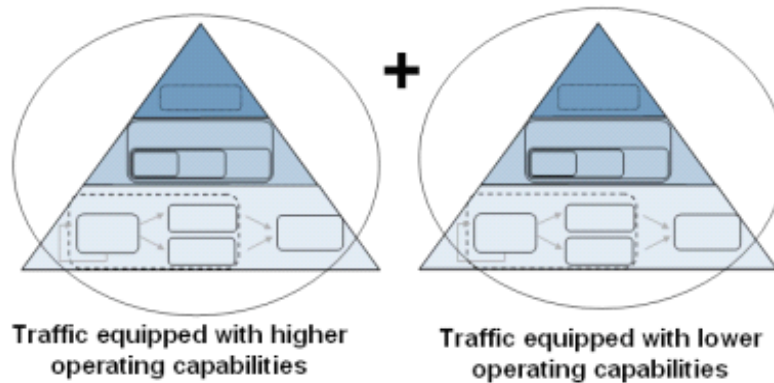

Figure 4-5. Airspace Segregation Decouples Mixed Equipage ATC Procedures

Decoupling mixed equipage procedures converts the overall problem into two independent problems, each with a homogeneous level of operating capabilities among aircraft. In mixed equipage environments with airspace segregation, controllers can still employ the same system abstractions and mental models that are currently used. Segregation reduces the need for controllers to develop new ways of thinking about the system during the transition period.

From the user perspective, airspace segregation could provide incentive to equip if airspace assets in high demand are allocated to those aircraft equipped with higher capabilities.

However, segregation also suffers from potential shortcomings which might limit its applicability. First, equipped and non-equipped aircraft need to be separated in different airspace locations as well as combined together for landing or when the segregation ends. If controllers are responsible for these tasks and they do not have adequate automation support, their cognitive complexity might rise above its maximum acceptable level. From the user perspective, the airspace allocated to the equipped aircraft might not be

attractive enough for airlines to retrofit their fleet. Moreover, segregation might impose excessive penalties on those aircraft equipped with lower capabilities. At an aggregate level, system performance also can be deteriorated. For example, if segregation is not adequately correlated with the number of equipped aircraft, the airspace reserved for equipped aircraft could be underutilized and system throughput could decrease. Figure 4-7 summarizes these concerns.

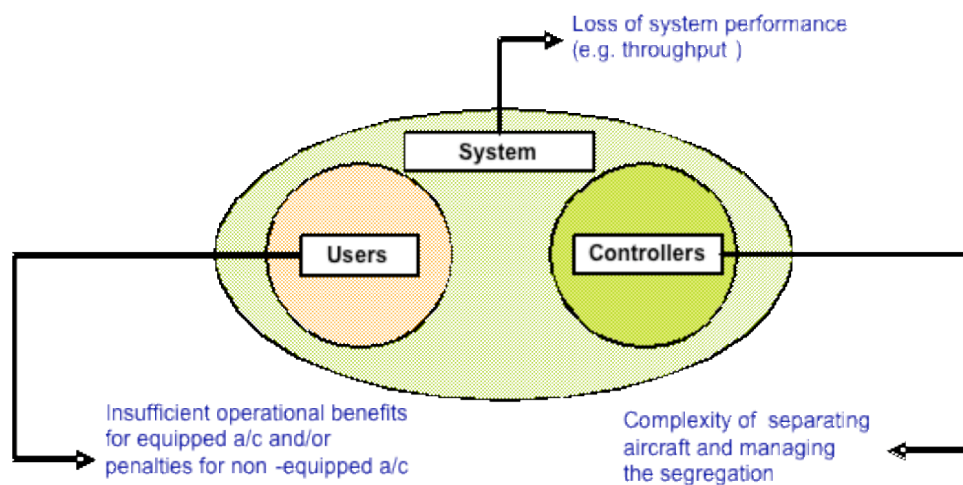

Figure 4-6. Potential Limits for Segregation

In conclusion, segregation should only be implemented (1) if the complexity of separating equipped and non-equipped aircraft as well as that of combining them together is acceptable for controllers, (2) if the operational benefits for the aircraft equipped with high capabilities as well as the potential penalties for those with low capabilities are acceptable for the airlines, and (3) if appropriate rules based on actual traffic mix are implemented so that system performance is not degraded.

4.3 Preferential Treatment

As discussed above, segregation is not always an appropriate mechanism for mixed equipage environments. An alternative to segregation is preferential treatment. This approach refers to the act of giving priority or other advantages to aircraft equipped with higher capabilities over those equipped with lower capabilities.

Preferential treatment is another good example of the multidimensionality of the mixed equipage problem. From the user perspective, preferential treatment could accelerate transitions and guarantee attractive benefits for the airlines that retrofit their aircraft with new operating capabilities. However, the main concerns with preferential treatment are its implications on controller cognitive processes and system performance.

Before implementing preferential treatment, the potential increase in cognitive complexity and workload for controllers should be quantified. The need for modifying controller tasks and ATC procedures as well as the need for decision support tools for controllers should also be evaluated.

4.4 Conclusions

Mixed equipage requires the implementation of mechanisms that minimize costs and maximize benefits for controllers and users during system transition periods. Airspace segregation has the potential to reduce controller cognitive complexity in mixed equipage environments if an adequate solution is found to manage the segregation. Furthermore, it might incentivize equipage adoption if high value airspace assets are allocated to those aircraft equipped with higher operating capabilities. However, in order to avoid underutilization of resources and negative effects on the system performance, segregation

also requires considering the level of mixed equipage and adequately allocating airspace assets to the equipped aircraft.

An alternative to segregation is preferential treatment, which provides high incentives for airlines to equip their fleet. However, implementing priority might penalize cognitive complexity of controllers and the performance of the aircraft equipped with lower operating capabilities.

Other potential strategies for mixed equipage could be, for example, to group the aircraft equipped with higher operating capabilities and to control these groups as single entities with priority over the rest of the traffic. This approach can be understood as a combination of dynamic segregation and preferential treatment. In this example, potential benefits for non-equipped aircraft are still a major concern. In addition, the size and the number of groups inversely affect system performance and controller cognitive complexity.

Decision support tools (DSTs) and subsidies are also valuable mechanisms for system transition. DSTs support controllers in mixed equipage environments, simplify their tasks, and limit their cognitive complexity. However, their design and implications need to be carefully considered. The introduction of new automation tools may negatively impact controller performance and safety ([17], [18], [19]). A human-centered design approach for the development of DSTs is required.

Subsidies constitute attractive benefits for the airlines and encourage them to retrofit their aircraft. As a result, system performance improves and the transition accelerates. Table 4-1 summarizes the discussion of potential strategies used to combat mixed

equipment implications highlighting the major considerations of each of them from the controller, user, and system perspectives

Table 4-1. Example of Potential Strategies to Combat Mixed Equipment Implications

Strategy for Mixed Equipment	Major Considerations		
	Controller Cognitive Complexity	Operational Benefits for Users	System Level Implications
Segregation	Decreases	Requires high value airspace asset	Requires adapting segregation to the traffic mix
Preferential Treatment	Increases	Potential penalties for non-equipped aircraft	Potential collateral effect on the global system performance
Grouping	Decreases	Requires preferential treatment to be applied to the group Potential penalties for non-equipped aircraft	Size and number of groups determine system benefits but also controller cognitive complexity
DST	Decreases	No effect	Indirect positive effect (less WL)
Subsidies	No effect	No effect (equipped a/c do not obtain direct operational benefits)	The more equipped a/c, the better system performance

The strategies presented in Table 4-1 are not exclusive. For example, preferential treatment can be combined with DST and subsidies. The selection of the appropriate strategy depends on the operating capability being introduced and the operational environment (e.g. existing procedures, route structure). Despite the fact that a particular strategy was selected, successful system transitions would only be possible if this strategy is acceptable for controllers and users and has a positive impact on the system performance.

5 North Atlantic (NAT) Operations

The implementation of reduced separation standards in the North Atlantic (NAT) is used in this thesis to illustrate the mixed equipage considerations discussed in previous chapters. Reduction of the existing separation minima in the NAT would enable more flights to adhere to their preferred route and optimal profile, and fewer delays. However, if mixed equipage implications are not adequately addressed the system transformation might never happen.

The rest of this thesis investigates the implications of the coexistence of flights in the NAT with different capabilities which are subject to different separation standards. It also explores the potential of segregation as a mechanism to facilitate the transition towards reduced separation standards in the NAT. The analysis is conducted in the context of and with the approach presented in Chapter 2.

Chapter 5 introduces the reader to the NAT operations. Next, Chapter 6 discusses the implications of mixed separation standards for the air traffic controller, Chapter 7 presents an analysis of the operational implications for the user, and Chapter 8 explores segregation strategies that do not compromise NAT airspace throughput.

5.1 Air Traffic Control over the North Atlantic

The North Atlantic (NAT) is the busiest oceanic airspace in the world with more than 370,000 flights in 2004 and annual traffic growth rates between 5% and 10% [20].

As shown in Figure 5-1, this region comprises five Oceanic Flight Information Regions (FIRs), each controlled by a different air navigation service provider: Gander Oceanic (controlled by NavCanada), New York Oceanic (controlled by the FAA),

Reykjavik (controlled by ISAVIA), Santa Maria Oceanic (controlled by NAV Portugal), and Shanwick Oceanic (controlled by NATS). NAT operations are coordinated among the different service providers, who guarantee seamless transitions between NAT FIRs. The fact that the implementation of new systems or procedures in the NAT must first be agreed upon by all parties complicates NAT ATM system evolution.

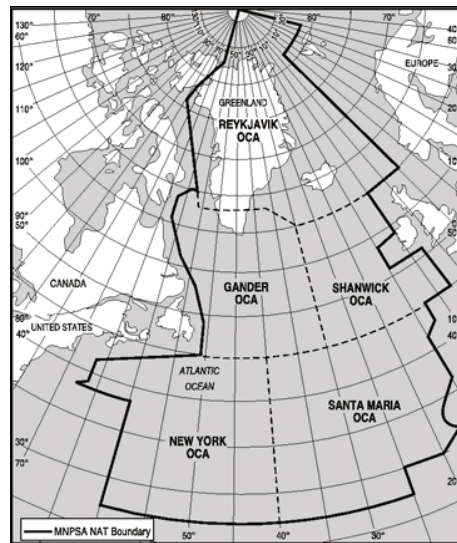

Figure 5-1. North Atlantic Flight Information Regions [21]

In addition to the large number of service providers involved, the complexity of managing NAT operations is also a result of limited communication and surveillance infrastructure. As shown in Figure 5-2, Very High Frequency (VHF) radio coverage is very limited in the NAT and currently, oceanic communication is mainly conducted over High Frequency (HF) radio through a third party communication relay service. Regarding surveillance, most of the NAT region is not covered by radar, so aircraft are surveilled by pilot position reports, which are given at approximately hourly intervals. The lack of direct communication between pilots and air traffic controllers and the

accuracy limitations of the surveillance process require the application of large separation standards in the NAT.

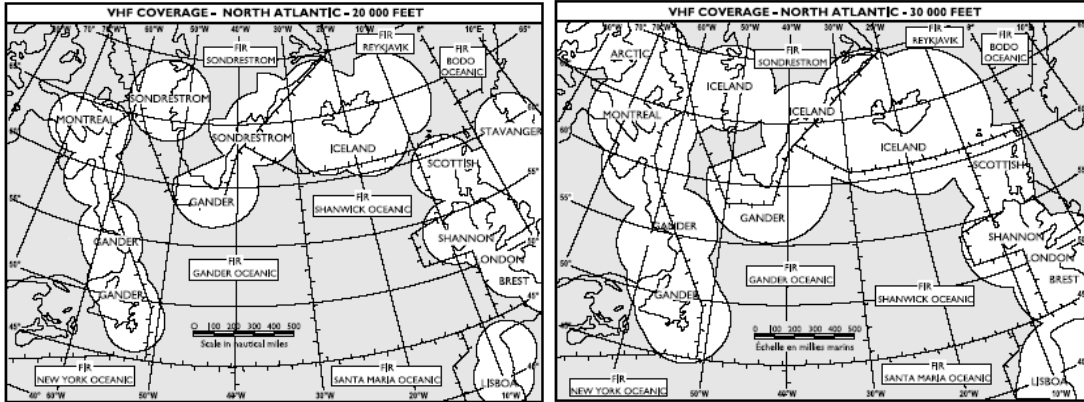

Figure 5-2. Very High Frequency Radio Coverage [21]

5.2 North Atlantic Organized Track System

The NAT route structure is known as the North Atlantic Organized Track System (NAT OTS). It refers to the trans-Atlantic air routes used by aircraft from North America traveling to/from Europe, flying between the altitudes of 29,000 and 41,000 feet, inclusive. The NAT OTS consists of 5 to 7 parallel tracks, 1 latitude degree apart, that reverse direction twice daily (i.e. westbound and eastbound tracks) to accommodate traditional airline schedules.

Each track is uniquely identified by a letter of the alphabet. Westbound tracks are indicated with a letter from the start of the alphabet (A, B, C, D, E) and eastbound tracks with a letter from the end (S, T, U, V, W, X, Y). Figures 5-3 shows the eastbound tracks corresponding to 4 May 2006.

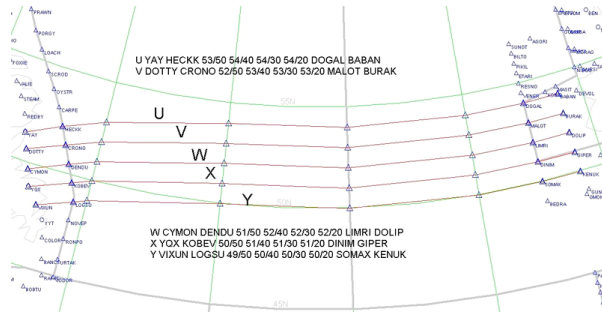

Figure 5-3. North Atlantic Eastbound Tracks on 4 May 2006

The position of the tracks is updated daily and the specific routing is dictated based on a number of factors, the most important being the winds. The NAT OTS comprises the minimum flight time tracks for a particular weather forecast that respect airlines' preferred routes and airspace restrictions [20].

While the tracks change daily, they maintain a series of entrance and exit waypoints which link them into the airspace system of North America and Europe.

5.3 Separation Minima

Separation minima in a given airspace are a function of the communication, navigation, surveillance, and air traffic management (CNS/ATM) capabilities, including air traffic system automation, available in that specific operating environment.

Due to the lack of surveillance and direct controller pilot communication, large separation standards are used in the NAT. In addition, since controllers do not have access to a radar display, time-based longitudinal separation minima are used to simplify their tasks.

Longitudinal separation minima are applied between aircraft flying along the same or intersecting tracks. Current standards require aircraft to be longitudinally separated by a

time interval equal to or greater than 30 minutes between a turbojet and any other aircraft, 15 minutes between turbojets, or 10 minutes between turbojets if the preceding aircraft is maintaining a Mach number equal to or greater than that maintained by the following aircraft [22]. If the preceding aircraft is maintaining a Mach number greater than the following aircraft, the separation minimum is reduced up to nine or five minutes, depending on the Mach difference. This separation technique is known as the Mach Number Technique.

Lateral separation, which is applied between route segments, is provided by the oceanic track structure. The tracks are spaced according to the minimum allowable lateral separation which is 60NM for MNSP³ aircraft

Figure 5-4 illustrates current separation minima in the NAT.

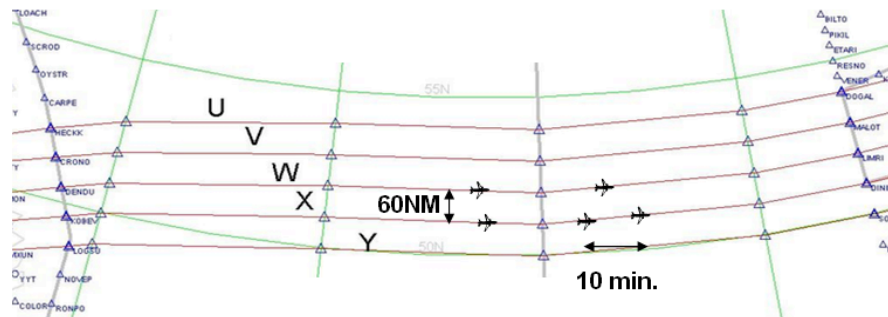

Figure 5-4. Current Separation Minima in the NAT OTS

Most NAT aircraft are subject to longitudinal separation minima of 10 minutes⁴, largely limiting NAT airspace capacity. As a result, the system cannot accommodate the

³ MNPS was introduced to enable a reduction in lateral separation minima, reducing the track spacing from 120 to 60NM; MNPS was the forerunner to Required Navigation Performance (RNP) [23]

⁴ 10 minutes is equivalent to approximately 80NM for NAT operations [22]

existing demand for the preferred routes at the preferred schedule and certain aircraft fly non-optimal trajectories and at non-optimal schedules.

5.4 Jet Stream

The jet stream consists of strong eastbound winds over the North Atlantic and is the main weather pattern in this region. Tracks from USA to Europe use the jet stream to their advantage by routing along the strongest tailwind so that flight time and fuel consumption are minimized for eastbound traffic.

The core of the jet stream is typically found at around 36,000 ft above the ground in the atmosphere with core speeds in winter frequently exceeding 120-150 knots [24]. These currents originate at the boundaries of adjacent air masses with significant differences in temperature. The cold polar air flows down from the north and meets warmer air masses, resulting in strong eastbound air currents [25]. During the winter months, the stronger surface temperature contrast leads to a strong jet stream. During the summer months, the surface temperature variation is less dramatic so the winds of the jet are weaker [26]. Figure 5-5 illustrates the jet stream on 17 March 2007 [27].

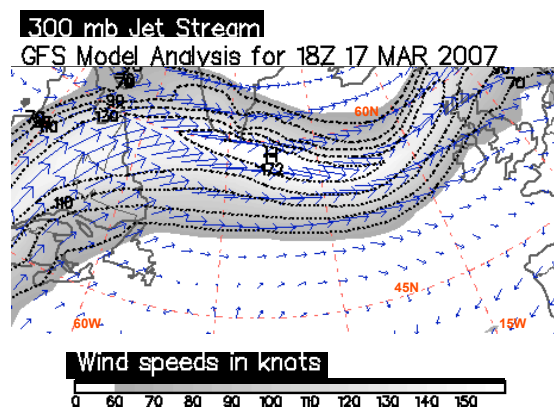

Figure 5-5. Jet Stream on 17 March 2007 [27]

Figures 5-6 and 5-7 illustrate how the NAT OTS is adjusted daily to the jet stream. As show in Figure 5-6, on 17 March 2007, strong eastbound winds blew along the NAT. Eastbound tracks, on the top of the right figure, were centered in the core of the jet stream, the white region in between the grey bands. Westbound tracks, on the bottom of the right figure, were positioned outside the jet stream region to minimize headwinds.

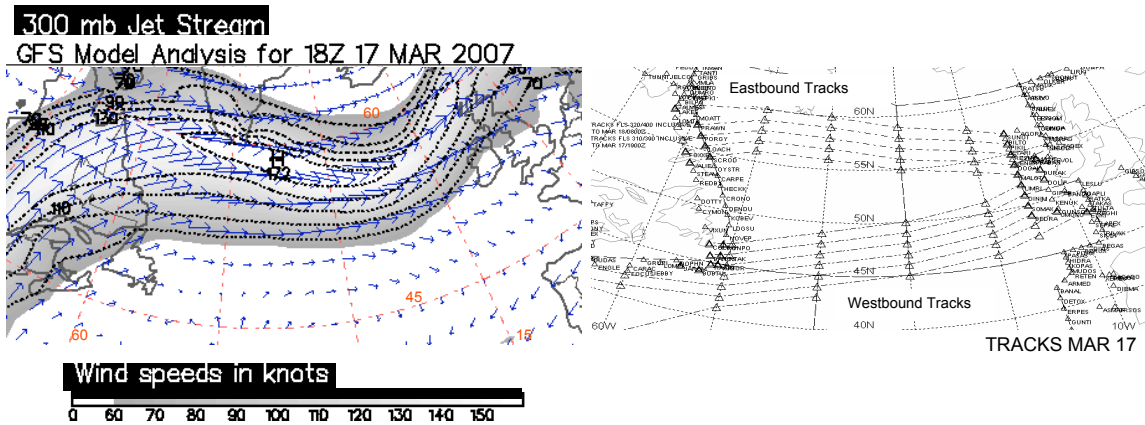

Figure 5-6. Jet Stream and Organized Track System on 17 March 2007 ([27], [28])

Figures 5-7 shows the jet stream and the NAT OTS on 20 March 2007. On this date, the jet stream was weaker and winds blew northbound and southbound rather than eastbound. Eastbound and westbound tracks were positioned so that tailwinds were maximized for the former and headwinds were minimized for the latter. As seen in Figure 5-7, both eastbound and westbound tracks looked different compared to those of 17 March 2007.

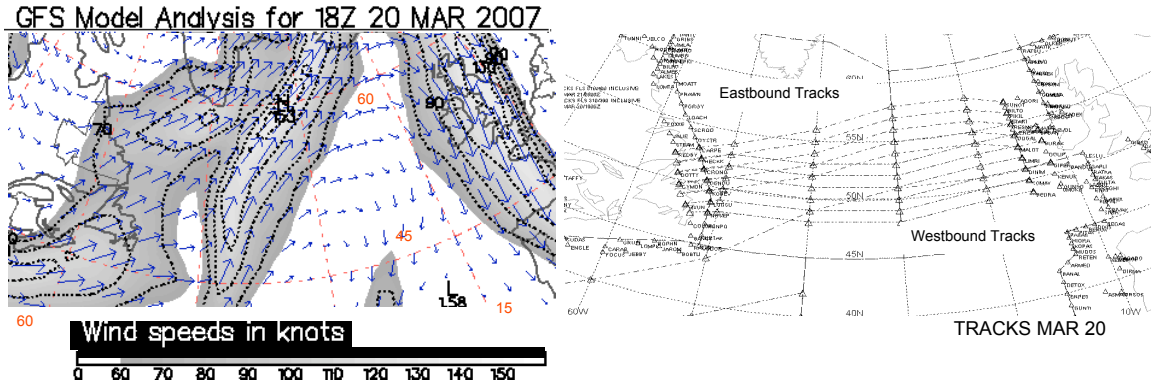

Figure 5-7. Jet Stream and Organized Track System on 20 March 2007 ([27], [28])

Nevertheless, the width of the jet stream is not wide enough to contain all tracks; some tracks receive more favorable winds and are preferable over others. Certain schedules are also preferable, leading to a temporal concentration of flights on the most preferred tracks: peak westbound traffic crossing the 30W longitude between 1130UTC and 1900UTC and peak eastbound traffic crossing the 30W longitude between 0100UTC and 0800UTC [20].

The next section discusses a simple model to estimate the operational cost impact of being on the most favorable track.

5.4.1 Modeling the Operational Cost Impact of the Jet Stream

This section explores the magnitude of the user benefits derived from being on the most favorable track by estimating the effect of the jet stream on the flight time. It should be noted that flight time is not the only operational benefit from flying the preferred track; however it illustrates its importance.

The effect of the jet stream on flight times can be estimated using observed models of the wind field in the vicinity of the jet stream as those developed by Reiter and Endlich

([29], [30]). Figure 5-8 shows average horizontal wind speed profiles based on experimental data for various profile classes.

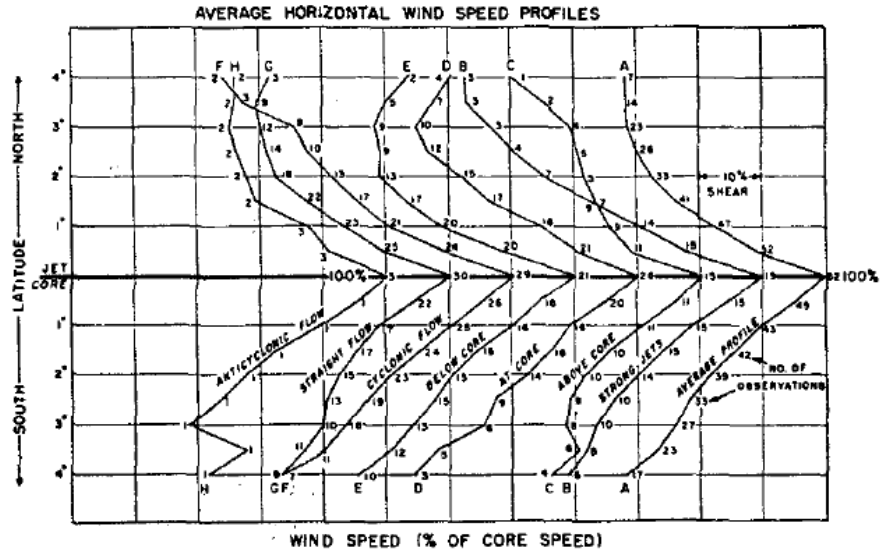

Figure 5-8. Horizontal wind speed (in % of maximum speed) for various profile classes [30]

These curves show that fairly constant shear occurs south of the speed maximum; north of the speed maximum, shear is about twice as strong as on the south side, amounting to 10% in the first 30 miles, then decreasing gradually.

Theoretically, assuming one of the NAT tracks was precisely located in the jet core, the flight time differences between tracks could be estimated using this model of the jet stream. In practice, the dynamics of the jet core makes it difficult to guarantee that one track is always in the jet core. But because of the constant slope of the wind speed curves to the south and north of the jet core (see Figure 5-8), such an estimation can still be valid as a preliminary estimate.

According to the model illustrated in Figure 5-8 and assuming that tracks are spaced 1 latitude degree, if one of the NAT tracks is located in the jet core (e.g. track W in Figure 5-9), on average, the tailwind in the adjacent north track (e.g. track V in Figure 5-9) is 15-20% lower and 10% lower in the adjacent south track (e.g. track X in Figure 5-9). Similarly, the tailwind decreases to 30% two tracks to the north of the core, and up to 20% two tracks to the south.

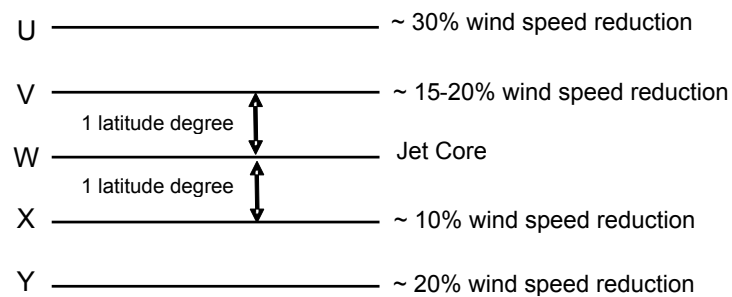

Figure 5-9. Example of eastbound tracks and average wind speed reduction per track.

The assumptions used in this simplified model of the impact of the jet stream on flight times and on the operating costs are the followings:

- The NAT region covers about 45 degrees longitude
- A track located at 55 degrees latitude and a flight level of 360 are representative of NAT trajectories
- A track length is approximately 1550NM
- A constant tailwind of 150 knots along the NAT is representative of the jet stream

- Mach Number 0.8⁵ is representative of the speed of NAT operations
- Airlines spend approximately \$100 per minute per flight in total operating costs (labor, fuel, maintenance, etc) [31]

Based on this simplified model, the jet stream creates flight time differences of 12 to 4 minutes. Results are shown in Table 5-1.

Table 5-1. Estimated Flight Time Differences Between Tracks as a result of the Jet Stream

Between U and W	Between V and W & between Y and W	Between X and W
12 minutes	8 minutes	4 minutes

These time differences can be converted into cost savings. Figure 5-10 shows a parametric analysis of extra operating cost as flight routes move away from the jet core.

⁵ Mach 0.8 is the cruise speed of B757 and B767.

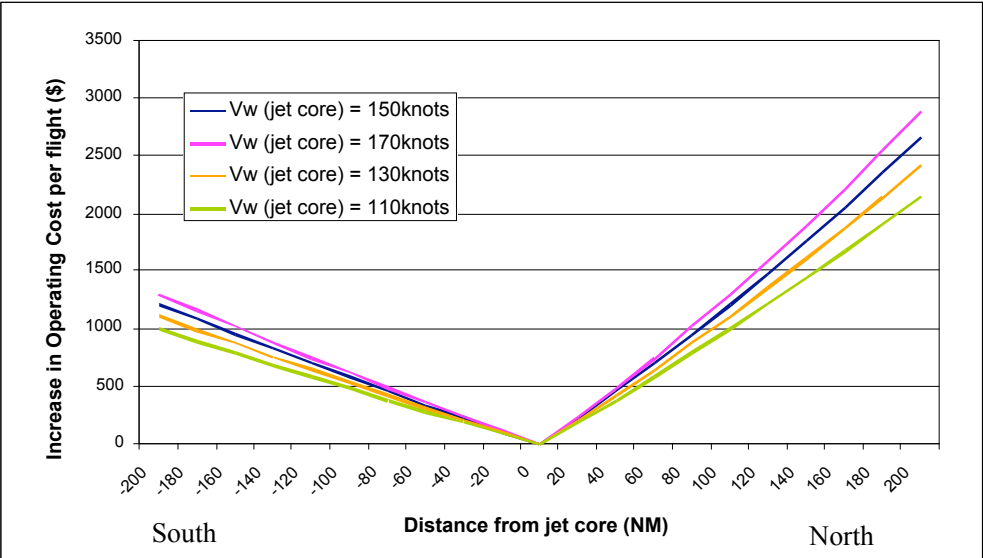

Figure 5-10. Parametric representation of extra operating cost as flights move away from the jet core

Based on this simplified model, the implementation of airspace segregation in the NAT could provide a potential maximum incentive for equipage adoption of 12 minutes flight time reduction. In economical terms, the incentive would be of around \$1200 cost savings per flight.

6 Reduced Separation Standards in the NAT: Cognitive Considerations

This chapter introduces the concept of reduced separation minima in the NAT and then, it presents and discusses the results of preliminary human-in-the-loop experiments on mixed separation standards. Results of these experiments show important human factor concerns, which suggest that mechanisms such as airspace segregation can be required during the transition period.

30/30 separation is used as an illustrative example because it has already been introduced in the South Pacific Region and the FAA plans to extent its implementation to the NAT.

6.1 30/30 Separation Minima

30/30 separation refers to the application of 30NM lateral and 30NM longitudinal separation minima instead of the current 60NM lateral and 10 minutes longitudinal separation minima. 30/30 introduces two main changes that may raise human factor concerns: transitioning from a temporal based longitudinal standard to a spatial based criteria and reducing both separation minima. In order to implement these changes improved surveillance and communication capabilities are needed. In particular, ICAO standards require the following: direct controller-pilot communication via voice or data

link, aircraft navigation accuracy to RNP-4⁶, and appropriate ADS-C⁷ position reporting and processing capability in the aircraft and at the oceanic center [33].

On 22 December 2005, the FAA introduced the first operational trial of 30/30 separation standards in the Pacific Region, in the Oceanic Sector 3 (OC3) of the Oakland Oceanic FIR. On 13 March 2007, the FAA decided to expand the use of 30/30 separation throughout the entire Oakland Oceanic CTA [32]. 30/30 was already being used in other parts of the South Pacific oceanic airspace such as the Australian Eastern Oceanic Area and the Auckland Oceanic, Nadi, Honiara, and Nauru FIRs.

The FAA plans include the implementation of reduced separation minima in other U.S.-controlled oceanic airspace [33]. Furthermore, 30/30 implementation is not only in the FAA agenda; NAT air traffic service providers have presented a global plan to implement 30/30 separation minima around 2013 [34].

30/30 implementation in the NAT is expected to occur in the near future but the NAT fleet is neither currently equipped nor expected to soon be equipped with the required operating capabilities. As a result, the implementation of 30/30 will generate a mixed equipage environment, at least during the first years of the transition. This makes the introduction of 30/30 separation minima an interesting example for the purpose of this thesis.

⁶ Required Navigation Performance (RNP) refers to the navigation performance accuracy necessary for operation within a defined airspace [35]. RNP types for en-route operations are identified by a single accuracy value which considers a combination of the different sensor and equipment errors.

⁷ ADS-C, Automatic Dependant Surveillance – Contract, refers to the transmission of airborne parameters to a specific address. It provides surveillance capability in oceanic and en-route continental airspace with no radar coverage; it is intended to replace verbal position reporting in these areas. ADS-C allows the establishment of communication contracts between ground systems and an aircraft's avionics system. These contracts contain the ATC data requirements and the frequency of the ADS-C reports [36].

Figure 6-1 illustrates the implementation of 30/30 separation in the NAT OTS. The reduction of current longitudinal separation from 10 minutes (~80NM) to 30NM would allow for the allocation of more flights to the preferred tracks at the preferred schedule. The reduction of lateral separation from 60NM to 30NM would allow having three tracks in the space currently assigned to only two tracks.

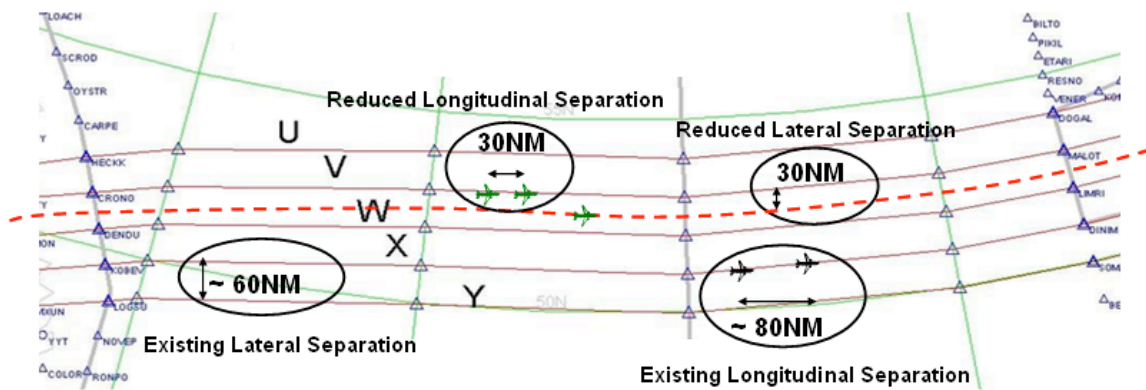

Figure 6-1. 30/30 Separation vs. Current Separation in the NAT OTS

6.2 Air Traffic Controller Considerations:

Experimental Studies

Prior studies on mixed separation standards in oceanic airspace suggest that it negatively affects controller situation awareness, task difficulty and performance. Major and Hansman [4] investigated the integration of different lateral separation minima into a common airspace region. The experimental results revealed human performance limitations. In particular, controller situation awareness degraded and the difficulty of the control task increased when mixed lateral separation standards were used. The level of mixed equipage studied was 50%.

Despite these experiments, there are no other studies on mixed separation standards with various levels of mixed equipage. The study reported in this thesis extends previous research to explore how controller performance varies with the level of mixed equipage.

6.2.1 Experimental Design

To further investigate the integration of different separation minima in the NAT under different levels of mixed equipage, a human-in-the-loop fast time simulation was conducted. Eleven scenarios with different levels of mixed equipage were created where flights eligible for reduced separation standards coexisted with flights limited to standard separation minima. Participants were requested to identify and resolve conflicts between aircraft. Traffic was distributed on three parallel tracks, which were laterally separated. For simplicity, the vertical dimension of the problem was eliminated. Aircraft's equipage level was indicated by color code. Magenta aircraft were equipped with higher capabilities (i.e. direct pilot controller communication, ADS-C, and RNP-4) and thus eligible for reduced separation standards. Green aircraft were equipped with lower capabilities and subject to conservative separation standards. Figure 6-2 shows a snapshot of the ATC oceanic simulation environment used for the experiment.

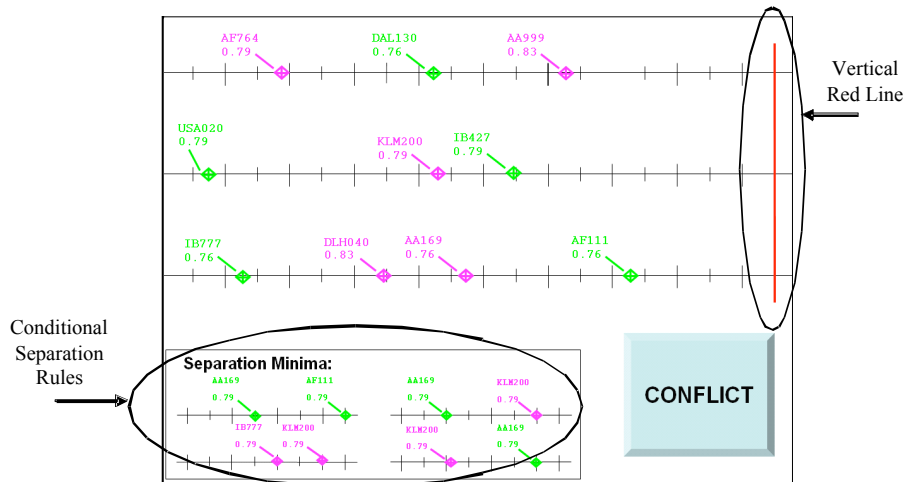

Figure 6-2. The ATC oceanic simulation environment

The participants' task was to monitor the traffic, identify pairs of aircraft that would violate the separation requirements if no action was taken, and resolve the conflicts using speed control. Each of the eleven scenarios had four conflicts to be identified by the controllers, two of which existed at the initial state of the scenario and the other two occurred before the completion of the scenario. Location of conflicts along the tracks was also controlled so that participants had, for all the scenarios, equivalent times before conflicting aircraft disappeared on the screen. The similar type and location of conflicts ensured a similar complexity level for all scenarios. In addition, the total numbers of conflicts between two equipped aircraft, two non-equipped aircraft, and one equipped and one non-equipped aircraft were counterbalanced.

Figures 6-3 to 6-5 illustrate the separation rules: non-equipped (green) flights should maintain at least 2 spatial units⁸ separation, while equipped⁹ (magenta) flights could reduce the distance to 1 spatial unit (see Figure 6-4 for information on the spatial scale).

⁸ Spatial units were represented in each track by the larger vertical lines. 1 spatial unit of the simulator was equivalent to 30NM

⁹ In this chapter equipped aircraft refers to those aircraft eligible for reduced separation standards

Equipped and non-equipped aircraft should be separated according to the conservative separation standards (i.e. 2 units). The conditional separation rules were always displayed on the screen to eliminate the effect of participants' differences in their ability to memorize the rules.

In the example illustrated in Figure 6-3, controllers should identify that the pair of aircraft on the right were in conflict, while the traffic situation on the left would not lead to any conflict. Similarly, in Figures 6-4 and 6-5 the pair of aircraft on the right were in conflict while the situation on the left would not lead to any conflict.

Non equipped aircraft should be separated at least 2 spatial units

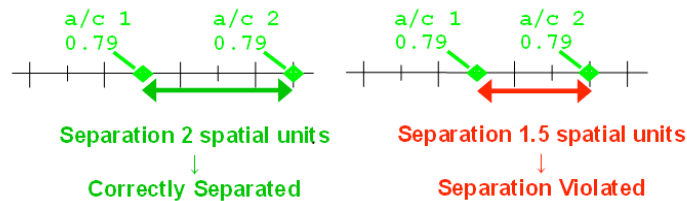

Figure 6-3. Separation requirements for the non-equipped aircraft

Equipped aircraft, should be separated at least 1 spatial unit

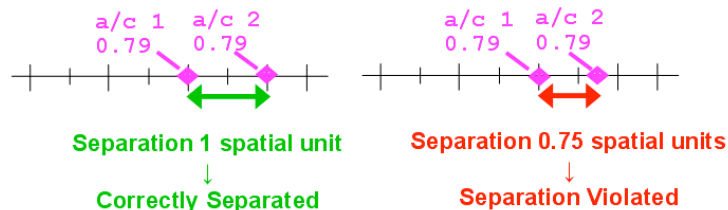

Figure 6-4. Separation requirements for the non-equipped aircraft

One non-equipped and one equipped aircraft should be separated at least 2 spatial units

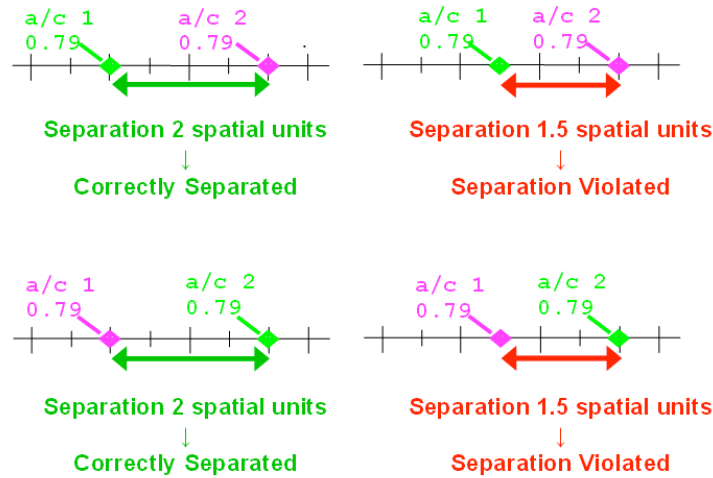

Figure 6-5. Separation requirements for one non-equipped and one equipped aircraft

In the simulation, separation violations could be present at the initial stage of the scenario or generated in future stages as a result of the scenario dynamics. As soon as participants identified an existing or future problem, they clicked on the “conflict” button located on the lower right corner of the screen (see Figure 6-2). Then, they said the word “conflict” and identified the call sign of the leading aircraft involved in the conflict. Finally, they issued speed commands to resolve the conflict. Participants were not requested to identify separation violations occurring after aircraft had crossed a vertical red line (see Figure 6-2). This task simulated the procedural control used in oceanic airspace, where air traffic controllers are responsible for separating aircraft at specific points.

The experiment was designed in a within-subjects format with one independent variable: the level of mixed equipage represented by the percentage of aircraft eligible for reduced separation standards (i.e. equipped with direct pilot controller communication,

ADS-C, and RNP-4). It varied between 0% and 100% with increments of 10% for each scenario.

The dependent variables were time-to-completion (the time required to identify all the conflicts through the conflict button and verbally identifying the conflict), omission errors (number of conflicts undetected), commission errors (number of non-conflicting aircraft identified as in conflict), and subjective rating of scenario difficulty. After completion of each scenario, participants rated the average difficulty of the task on a ten-point scale and, at the end of the experiment, completed a questionnaire. In this post-experiment questionnaire, participants were asked to list the factors affecting scenarios' difficulty and their ability to identify conflicts.

Each simulated scenario consisted of ten aircraft evolving through an organized track structure typical of the NAT. Each aircraft was represented by a rhombus as depicted in Figures 6-2 and 6-6, and its call sign and Mach number were displayed on the screen. The aircraft's Mach number was included because this information is available for controllers in actual operational environments.

The simulator time scale was about 30 times faster than real time to allow multiple scenarios to be studied in a reasonable amount of time. The spatial scale was 1 spatial unit corresponding to 30 NM (spatial units were represented in each track by vertical lines). In addition, each spatial unit was composed of two subunits that were also displayed by smaller vertical lines in order to help subjects visualize flight dynamics. Both units and subunits are represented in Figure 6-6.

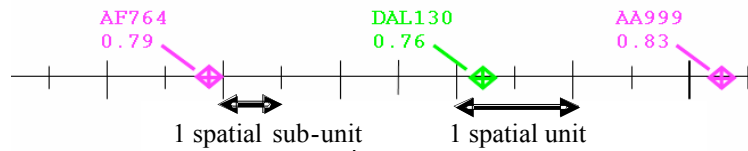

Figure 6-6. Spatial scale

6.2.2 Experimental Protocol

Seven French air traffic controllers with an average experience of 1.5 years in an operational control position participated in this experiment.

After signing a consent form, participants filled in a demographic questionnaire and read a brief overview of the experiment. They, then, completed a tutorial and three practice scenarios. Following this, they completed the eleven test scenarios, identifying the perceived level of difficulty of each scenario right after its completion. The order in which each participant completed the scenarios was randomized to prevent results from being biased by a learning effect.

6.2.3 Results and Discussion

Experiment results show that errors were more likely to occur with low-medium percentages of equipped traffic. In particular, most omission errors (undetected conflicts) occurred when the percentage of equipped aircraft was below 50% and all commission errors (non-conflicting aircraft that were identified in conflict) were committed in scenarios with a percentage of equipped traffic between 20% and 60%. Figures 6-7 and 6-8 show the number of errors committed.

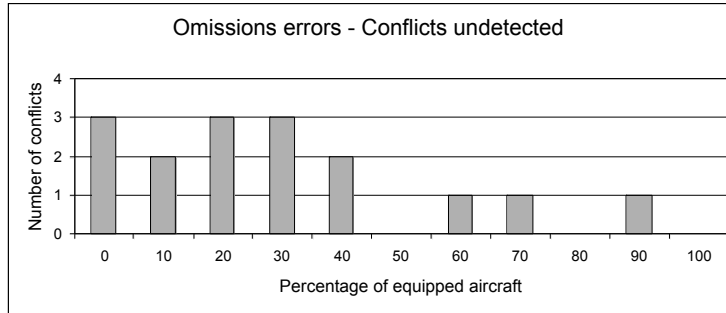

Figure 6-7. Total conflicts undetected vs. percentage of equipped aircraft

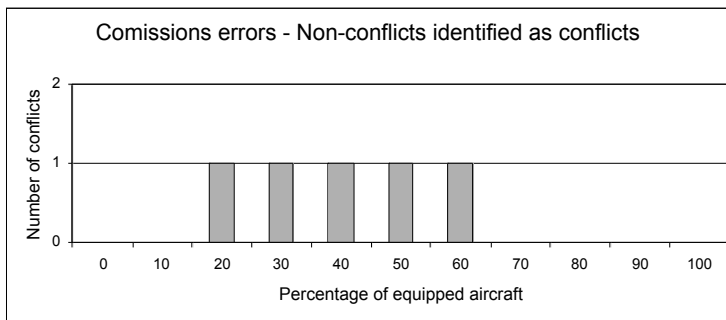

Figure 6-8. Total commission errors vs. percentage of equipped aircraft

It is notable that conflicts between two non-equipped aircraft were more likely to be undetected than errors between two equipped aircraft. The total number of undetected conflicts depended significantly on the level of equipage of the aircraft involved (p-value = 0.0467) according to the non-parametric chi-square test. Details on the test can be found in Appendix A.

Table 6-1 shows the total number of existing conflicts that each participant should have detected. Figure 6-9 illustrates the total number of undetected conflicts for all participants.

Table 6-1. Total number of existing conflicts vs. aircraft equipage levels per participant

Non equipped & Non equipped	Non equipped & Equipped	Equipped & Equipped
14	16	13

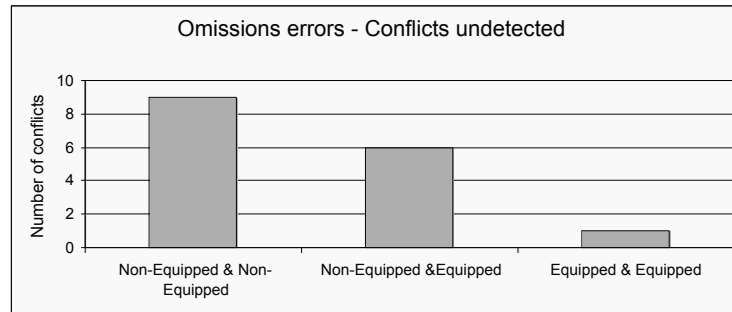

Figure 6-9. Total omission errors vs. aircraft involved in conflict

The significant difference in the number of conflicts undetected for different levels of equipage suggests that air traffic controllers had difficulties with conditional separation standards; they tended to handle the traffic as if the conservative separation standards were applicable to both equipped and non-equipped aircraft. After the experiment, controllers were asked to report their conflict search strategy. Three out of seven explained that, regardless of the equipage level, they associated the conflict risk with the distance between aircraft.

The heuristic “the closer the aircraft, the higher the risk of conflict” is useful for the current air traffic management system; however, in the case of conditional separation requirements this rule biases the type and number of errors committed. Current mental model and system abstractions such as thinking about the system in terms of distances between aircraft pairs are non-applicable to conditional separation standards.

Regarding commission error, results show that controllers were more likely to increase separation between two aircraft no requiring controller intervention if both were equipped. This result also supports the observation that controllers applied in this experiment the rule “the closer the aircraft, the higher the risk of conflict” that is based on their current mental models and abstractions. Figure 6-10 illustrates the total number of commission errors committed by all participants.

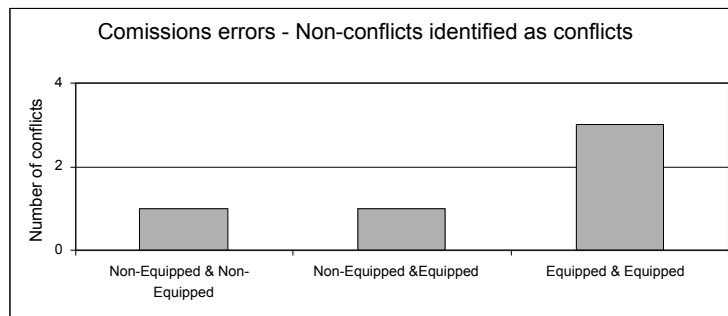

Figure 6-10. Total commission errors vs. aircraft involved in conflict

Regarding the average time-to-completion and the perceived level of difficulty, results showed no significant differences among scenarios. Boxplots of these results are shown in Figure 6-11¹⁰. The bars indicate the first and the third quartiles (i.e. 25% and 75% of the data values are less or equal to the lower and the upper limits respectively). The horizontal lines within the bars represent the median values. The upper and lower whiskers mark the interval corresponding to 3 times the standard deviation from the mean.

¹⁰ The scenario with 60% of traffic equipped is not included in the graph because this scenario presented a smaller number of conflicts due to an experimental mistake

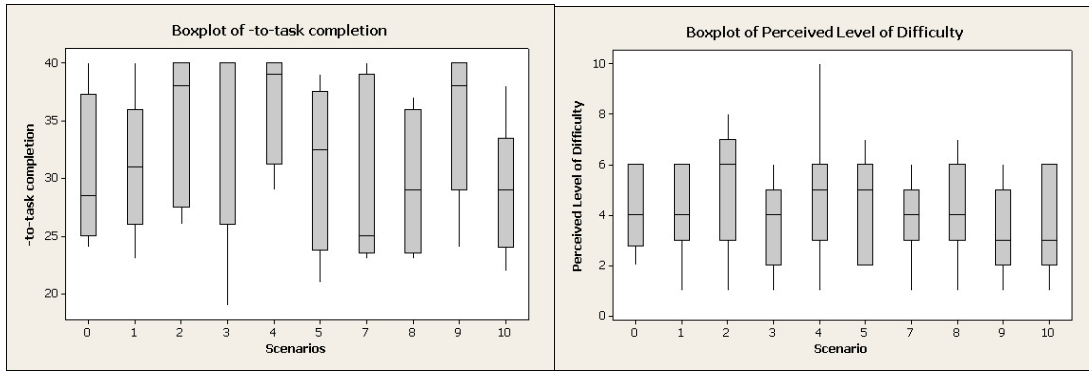

Figure 6-11. Time-to-task completion and Perceived level of difficulty

The perceived level of difficulty was measured in a ten-point scale, with one being “very easy” and ten being “impossible”. The average time required to complete the task was calculated based on data from five air traffic controllers due to a time-data recording problem with the other two participants. The average time represented in the figure takes into account the errors committed. Since the task was to identify and resolve the four conflicts, in the case of undetected conflicts the time-to-completion was considered equal to the total duration of the scenario.

Finally, Figure 6-12 illustrate controllers’ answers to the question of what made a scenario easier or more difficult than another scenario. Five out of seven of the air traffic controllers (71%) reported that mixing traffic with different operating capabilities ge made scenarios more difficult. In addition, two air traffic controllers (28%) also enumerated the number of equipped aircraft as a factor: the more equipped the aircraft, the easier the scenario.

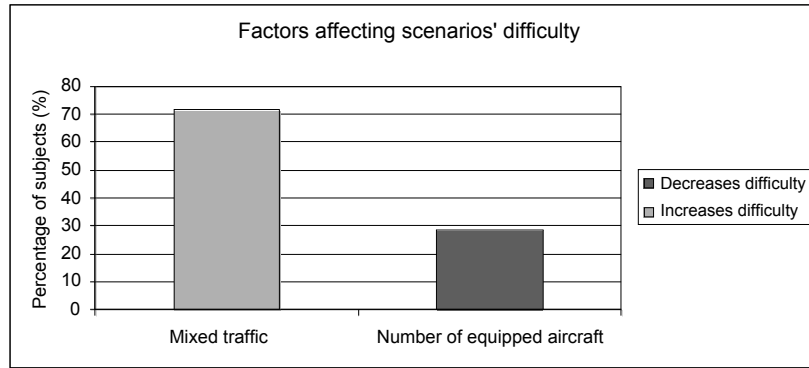

Figure 6-12. Factors affecting scenario difficulty as reported by air traffic controllers

A potential confounding factor in this experiment is the difference in difficulty associated to monitoring each separation requirement. Air traffic controllers reported that separation requirements for equipped aircraft (1 distance unit) were easy to monitor visually, while conservative separation minima (2 distance units) required them to count the actual spatial units.

6.3 Conclusions

Other mixed equipage studies, such as Barker [37], have concluded that controllers can accommodate a certain percentage of equipped aircraft without performance degradation. Baker points out that controller's tolerance is determined by the complexity of procedures. However, the results of this experiment suggest that controllers have higher error rates at very low mixed equipage levels.

This is particularly important because it is during the first stages of any system transition that humans' natural resistance to change must be overcome. If mixed equipage creates additional complexity, especially with low levels of mixed equipage, air traffic controllers are likely to oppose system transformation.

Another human factor issue identified in the experiment is the use of current system abstractions in mixed equipage environments. Results suggest that participants committed additional errors because of inappropriate system abstractions. Participants in this experiment associated the conflict risk with the distance between aircraft. As a result, they were more likely to undetect a conflict if both aircraft were non-equipped (and farther apart), and to increase separation between two aircraft not requiring controller intervention if both were equipped (and closer).

Therefore, as these experimental results reveal, the implementation of reduced separation minima in the NAT region without providing oceanic controllers with additional support raises important human factor concerns. Airspace segregation can be an appropriate mechanism to combat them. Separation of equipped and non-equipped aircraft would enable air traffic controllers to represent and model the traffic as two groups, spatially differentiated, with homogeneous equipage levels instead of as one group of aircraft with non-homogeneous equipage levels. Moreover, the equipped and non-equipped aircraft control problems would be decoupled and air traffic controllers could resolve them independently.

7 Reduced Separation Standards in the NAT: Operational Implications

As discussed in Chapter 6, the implementation of 30/30 in the NAT will result in more aircraft flying optimal routes but it will also have negative cognitive implications for controllers. If the increase of complexity is not controlled, the operational benefits could be severely limited.

Airspace segregation is a mechanism that can be implemented to mitigate the excess of complexity resulting from mixed equipage. Spatially differentiating the flights eligible for 30/30 from those eligible for conservative separation standards can also encourage airlines to equip their fleet. As mentioned in Chapter 5, the jet stream and the route structure create tangible benefits for the flights allocated to the minimum flight time track. Therefore, the NAT is a priori an appropriate scenario for segregation.

Segregation will contribute to accelerate the transition to 30/30 separation minima if it materializes attractive incentives for the airlines to equip their aircraft with ADS-C, RNP-4 and datalink. This chapter analyses actual flight times to further explore the benefits derived from being in the most favorable track as a first step to evaluate the potential for incentivization schemes based on segregation.

7.1 Operational Analysis of NAT Operations

A statistical analysis of actual flight times of eastbound NAT traffic per track for a particular day was performed to better understand the operational benefits derived from the jet stream. The date selected for the analysis was 8 December 2006.

Figure 7-1 illustrates the jet stream on 8 December 2006. As shown in the figure, a strong jet stream was present throughout the NAT region.

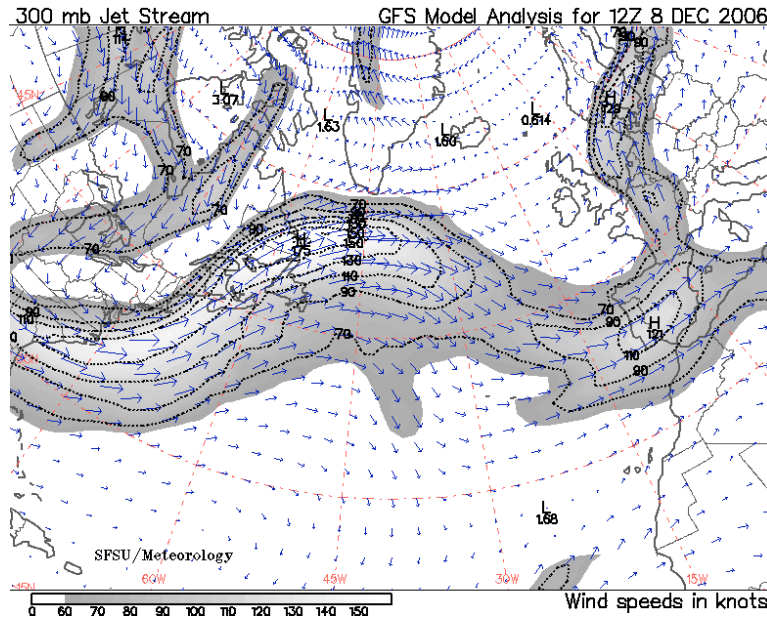

Figure 7-1. Jet Stream over the NAT on 8 December 2006 [27].

7.1.1 Methods

Traffic data was obtained from the Enhanced Traffic Management System (ETMS), a tool used by the Federal Aviation Administration (FAA) at the Air Traffic Control System Command Center (ATCSCC), the Air Route Traffic Control Centers (ARTCCs), and major Terminal Radar Approach Control (TRACON) facilities to manage the flow of air traffic within the National Airspace System (NAS). Data included only North Atlantic flights, defined as flights originating in the United States and destined for one of the North Atlantic countries; all military flights were excluded. The file contained one record for each radar hit (or oceanic position report) for each North Atlantic flight. Each record contained flight identification fields, time, and current latitude and longitude in degrees. The original file contained 636 flights, but only 360 of these flights were

eastbound. Moreover, only 234 of these eastbound flights had information on both entry to and exit from the NAT region.

The flight time required to cross the NAT is calculated in this study from the instant the flight overflies the entry point to the NAT region until the flight overflies the meridian corresponding to longitude 8W (where the exit points are approximately located). In this study, entry points are considered equivalent to flight routes because each track of the NAT OTS is identified by one of 16 fixed entry points to the NAT region (see Figure 7-2 on the left). Figure 7-2, on the right, displays the radar hits for 8 December 2006. As shown, most flights (81% of the total eastbound traffic) entered the NAT by one of the following five entry points: CARPE, HECKK, CRONO, DENDU¹¹. These are the four entry points used in this comparative study.

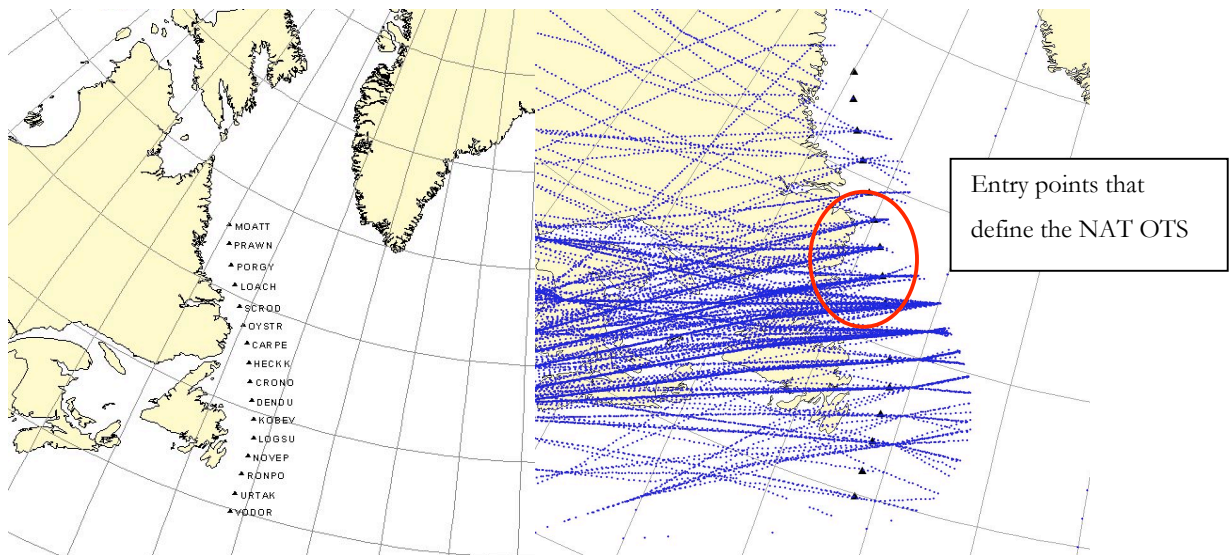

Figure 7-2. Entry points in the NAT and. Radar Data on 8 December 06

The aircraft type also affects flight time, so this parameter was also included in the model. As shown in Figure 7-3, seven main aircraft types flew over the NAT on the day

¹¹ Considering only four entrypoints, we reduced the sample size from 234 to 189.

in question but the sample sizes of each type were too small to analyze the seven categories separately.

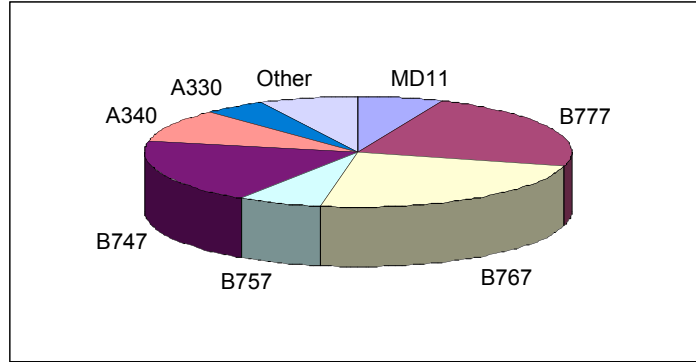

Figure 7-3. Distribution of aircraft type for eastbound traffic on 8 December 2006

Instead, aircraft were grouped in three categories based on their cruise speed, as shown in Figure 7-4. A340 could have been included in group 1 or 2. It was included in group 2 because it seemed reasonable to have both Airbus models (i.e. A330 and A340) together in the same category. Other types of aircraft not corresponding to these seven types were eliminated from the sample, reducing the sample size an additional 7%.

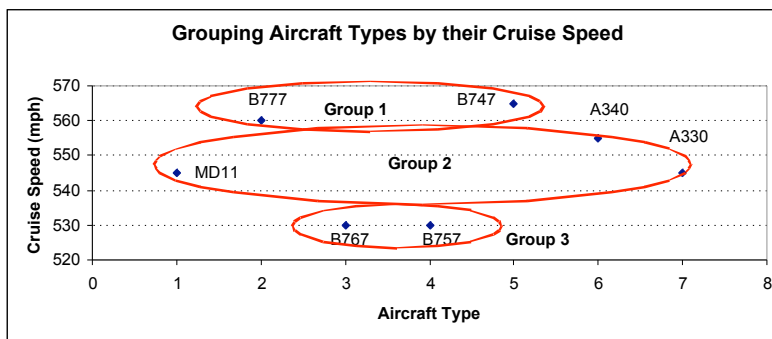

Figure 7-4. Aircraft type categorization based on cruise speeds.

Besides the entry point and the aircraft type, the entry time in the NAT also affects flight time. In order to understand the significance of this variation, this study compares

the variability of flight times between two time periods (from 2 to 4am and from 4 to 6am). These time periods were selected because, as shown in Figure 7-5, most eastbound traffic occurs early in the morning. The number of flights in these two categories was 50 and 47 respectively. Narrower time intervals could not be studied because of the total sample size.

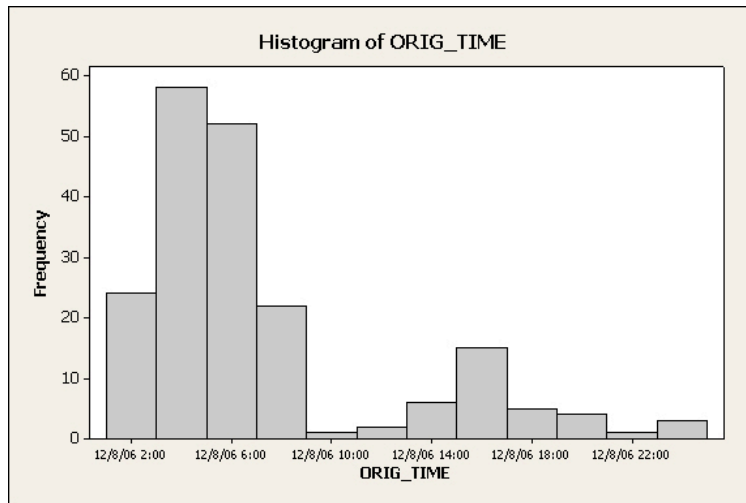

Figure 7-5. Histogram of the entering time in the NAT for eastbound traffic on 8 December 2006.

7.1.2 Results

The 4x2x3 ANOVA model results showed statistical significance for the three factors under consideration (entry point, entry time, and aircraft category), which confirms the validity of our model. No significant interaction effects existed between aircraft category and entry point, but they existed between entry point and entry time (as expected) and between entry time and aircraft category. The latter is probably a consequence of the grouping (if more data points were available a finer partition could have been done) and the heterogeneous distribution of aircraft type throughout the day.

The coefficient of determination (R2) for this model is 81.48%, which means that 81.48% of the flight time variability can be explained with these three factors. The P-values for this 4x2x3 ANOVA model are shown in Table 7-1.

Table 7-1. Results from the 4x2x3 ANOVA model

	P-value
Entrypoint	<0.001
Entry Time	0.004
Aircraft Category	<0.001
Entrypoint * Entry Time	0.059
EntryTime * Aircraft Category	0.032

Figure 7-6 contains a boxplot of the data sample as a function of the entry point and entry time. As shown in this figure, significant flight time variations exist depending on the allocated track and the entry time.

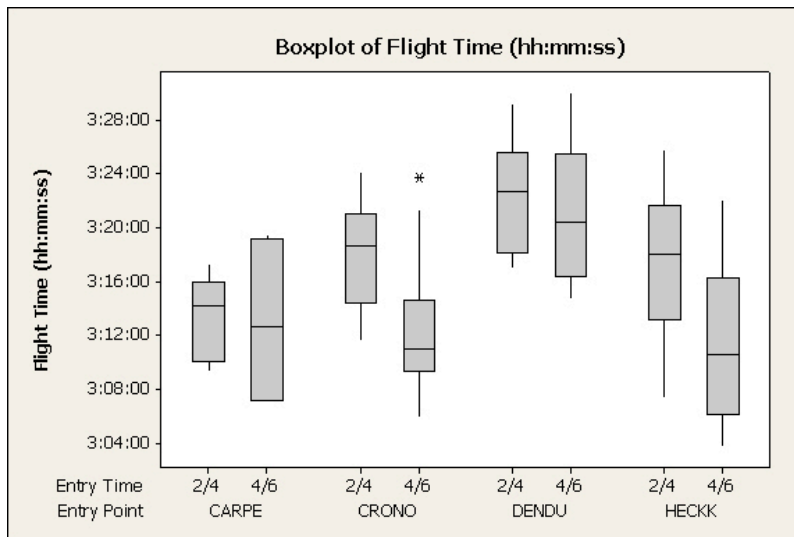

Figure 7-6. Boxplot of flight time vs. Entry point, Entry time, and Aircraft Type

Figure 7-7 illustrates the mean flight time per entry point and entry time. For the day under study, CARPE was the minimum flight time track, the rest of the tracks being

located south of it where the wind speed reduction is less dramatic. The largest flight time difference was between CARPE and DENDU entry points. The variability of the flight times is not homogeneous for all entry points. For example, the flight time for DENDU seemed to remain practically constant from 2am to 6am while flight times for CRONO and HECKK seemed to decrease significantly from 2-4am to 4-6am. Figures for each individual aircraft category can be found in Appendix B.

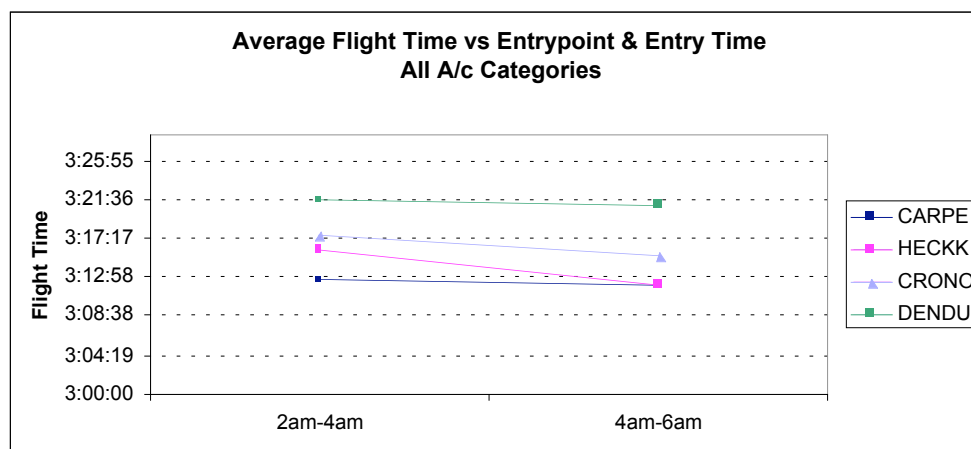

Figure 7-7. Mean flight times between 2-4am & 4-6am vs. Entry point

Table 7-2 and Figure 7-8 compare mean flight time differences between tracks based on the actual flight data with the estimations of Chapter 5. The contrasts have been calculated with the Bonferroni method. The corresponding confidence intervals are included in Appendix C.

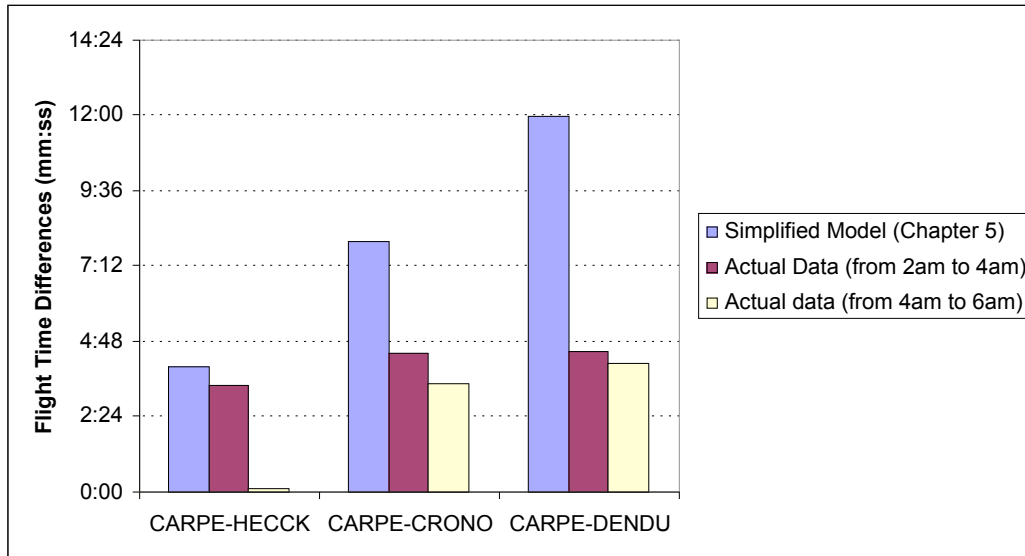

Figure 7-8. Mean Flight Time Differences: Actual Fight Data vs. Simplified Model

Table 7-2 Mean Flight Time Differences per Entry Point and Entry Time (all aircraft categories)

Entry Time	Flight Time Differences between 2 tracks (mm:ss)		
	CARPE-HECCK	CARPE-CRONO	CARPE-DENDU
From 2am to 4am	-3:25	-4:25	-4:30
From 4am to 6am	-0:08	-3:28	-4:07
Simplified Model (Chapter 5)	4:00	8:00	12:00

The estimates provided by the simplified jet stream model are of the same order of magnitude but slightly larger than the estimates calculated from the actual traffic data. Results suggest that the difference in the average flight time between the most favorable track and the other tracks may be more constant than that predicted by the simplified model.

Regarding the dynamics of the jet stream and the variability of the operational benefits with the period of the day, results suggest that the flight time differences between the same two tracks vary significantly depending on the entry time. For example, for the time interval 2-4am, statistical significance is found between CARPE & CRONO, and CARPE & DENDU but for the time interval 4-6am, statistical significance is obtained only between CARPE & DENDU. In order to explore how well traffic adapts to these changing conditions, the percentage of flights using each track for the two time entry categories is shown in Figure 7-9.

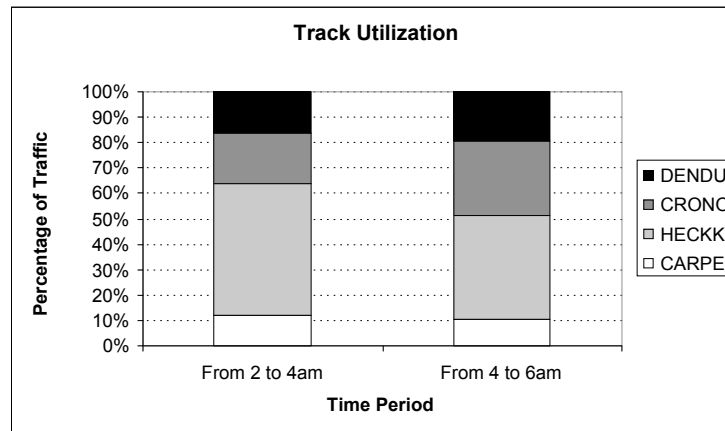

Figure 7-9. Track utilization between 2-4am & 4-6am

According to the chi-square independence test, the number of aircraft allocated to each track that day was independent of the entry time (P-value = 0.6128). The trend, based on Figure 7-9, was that more flights entered the NAT through CRONO and less through HECKK from 4 to 6am. However, as shown in Figure 7-7, most flight times through HECKK were shorter than those through CRONO for that time interval. The distribution of flights in tracks seems to be inconsistent with the actual flight times: more aircraft are allocated to longer tracks. This result suggests that there is not dynamic

adjustment between the jet stream and the traffic allocation to tracks and that users are not taking full advantage of the potential operational benefits.

7.2 Conclusions

Incentivization policies such as allocating the minimum flight time track to the aircraft equipped with RNP-4, ADS-C, and CPDLC would accelerate the NAT transition to 30/30 separation minima only if the value of the operational benefit offered is equivalent if not larger than the cost of equipping with the required capabilities. A preliminary estimation of flight time differences between tracks provides figures of time savings around 5 minutes.

In addition, the analysis of actual flight times suggests that it could be possible to provide larger operational benefits to the users. Results confirm that the benefits of flying a particular track can significantly vary during the day. A more dynamic route structure and air traffic control would probably lead to shorter flight times, and so larger operational cost savings.

Finally, it should be noted that further analysis is still required to understand the effect and potential benefits of the jet stream on the NAT operations. In particular, studies that include larger samples sizes over several days, wind speed as a factor in the model, finer control of flight times' variability due to aircraft type, and narrower entry time intervals could provide valuable insights.

8 Reduced Separation Standards in the NAT: System Level Considerations

The previous two chapters have discussed segregation of flights eligible for 30/30 in the NAT from the controller and the user perspectives. Results suggest that segregation could have beneficial effects at these two levels, however there are still system level concerns that require further consideration. For example, segregation can lead to resource underutilization if the most favorable track is reserved only for equipped aircraft and its number is small. Another potentially negative effect is due to the fact that the distribution of equipped aircraft might not be homogeneous all day long. In these cases, dynamic strategies that adapt to traffic evolution and enable maximization of system performance might be necessary.

This section explores appropriate segregation rules or principles that can guarantee, at the very least, maintenance of the current maximum NAT throughput rate. System throughput is a relevant dimension that should be considered in the analysis of aggregate effects. This dimension is used in this thesis to illustrate the approach proposed. That said, as mentioned in Chapter 2, it is not the sole dimension to study.

8.1 Methodology

In order to study maximum throughput, the system is modeled as a set of individual channels, each with a maximum throughput per channel. System throughput is the sum of the channel throughput. Such a vision of the system is particularly useful to study segregation because segregation can also be understood as the process of separating flights into different channels.

A channel is defined in this study as any spatial entity where traffic can be allocated and can serve as the basis for segregation. For example, arrival traffic is allocated to landing runways and each landing runway constitutes a channel, en-route traffic is allocated to flight levels and each flight level constitutes a channel. In our example, NAT eastbound traffic can be allocated to 55 different channels: 5 eastbound tracks, each with 11 flight levels (eastbound traffic can fly any flight level between and including 410 and 310 [38]). The approach proposed in this chapter is applicable to any system where separation minima are reduced and that it can be decomposed in terms of channels. Figure 8-1 illustrates the available channels in the NAT for segregation.

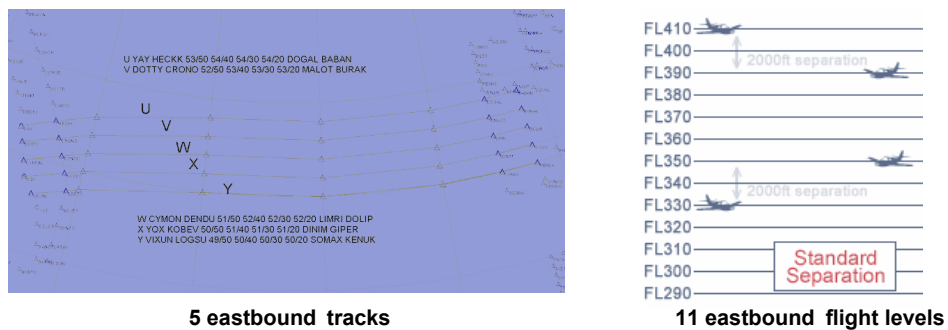

Figure 8-1. NAT Eastbound tracks & Flight Levels

The maximum throughput rate of these channels will depend on the separation requirements, which in turn depend on the aircraft capabilities. The more advanced the capabilities, the less conservative the separation requirements and the larger the maximum throughput rate.

One of the assumptions of this study is that no mixed channels in terms of separation requirements exist; only one of the two separation requirements (i.e. reduced or conservative separation) is applicable to each channel. A major reason to implement

segregation, spatial differentiation between regions where each separation requirement is applicable, is to decouple the mixed equipage ATC procedures and decrease controller cognitive complexity. Permitting the existence of mixed channels would be contrary to this objective.

The maximum system throughput will also depend on the segregation rules (i.e. how many channels are allocated to aircraft with higher and lower capabilities) and the number of aircraft equipped with higher and lower capabilities. If too many channels are allocated to equipped aircraft and there are not enough equipped aircraft to fill these channels, the system is underutilized and the maximum throughput decreases. On the other hand, if too few channels are allocated to equipped aircraft, the system throughput is not maximized because there are equipped aircraft that could be closer but are allocated to channels with conservative separation standards.

Figures 8-2 illustrates an example of static segregation: a fixed number of channels are always reserved for the aircraft equipped with higher capabilities. When the number of equipped aircraft is small, channels reserved for these aircraft are almost empty and throughput suffers. As the number of equipped aircraft increases, the reserved channel fills and the maximum throughput increases. If the number of equipped aircraft continues to increase, reserved channels are full and some of these equipped aircraft have to be allocated to other channels and separated according to the conservative separation standard.

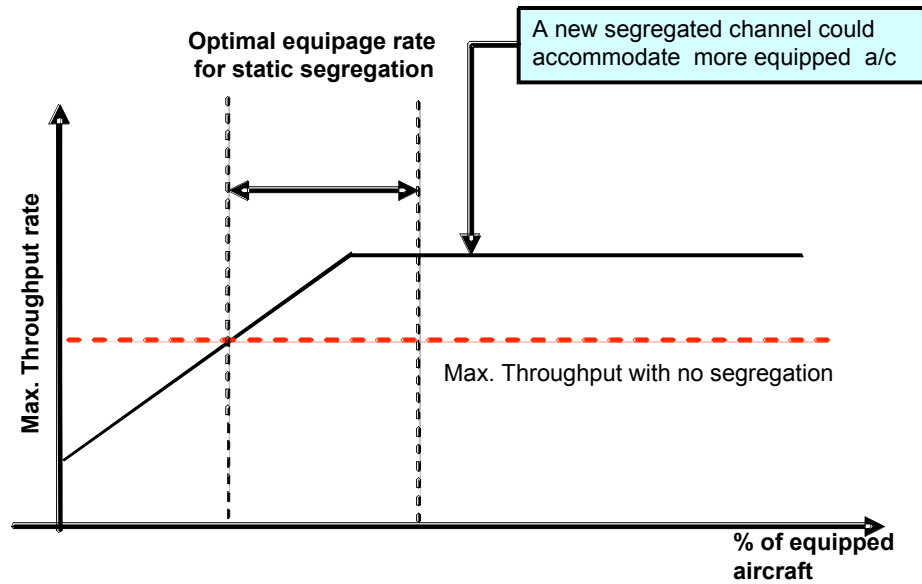

Figure 8-2. Example of Static Segregation. Maximum Throughput as a Function of % of Equipped Aircraft

As shown in Figure 8-2, a potential problem of static segregation is that throughput is only maximized for a certain range of equipage rate. If there are too few equipped aircraft maximum system throughput is lost, if there are too many equipped aircraft additional system throughput could be gained opening new segregated channels. This limitation will always exist if the number of segregated channels is fixed and the number of equipped aircraft per unit of time varies during the day. The relevance of potential throughput losses depends on the variability of the equipage rate.

As discussed in Chapter 4, an alternative to static segregation is dynamic segregation, where channels' configuration changes and adapts to traffic. Figures 8-3 illustrates an example of dynamic segregation: In this example, when the number of equipped aircraft per unit of time is small, throughput is still lost because the channels reserved for equipped aircraft are almost empty. The difference is that now, when the

channels reserved for equipped aircraft are full, a new channel is opened to accommodate the remaining equipped aircraft with reduced separation minima. If few aircraft are allocated to this new channel, system throughput is also lost because the channel that has just been opened is underutilized. As this channel fills, system throughput increases.

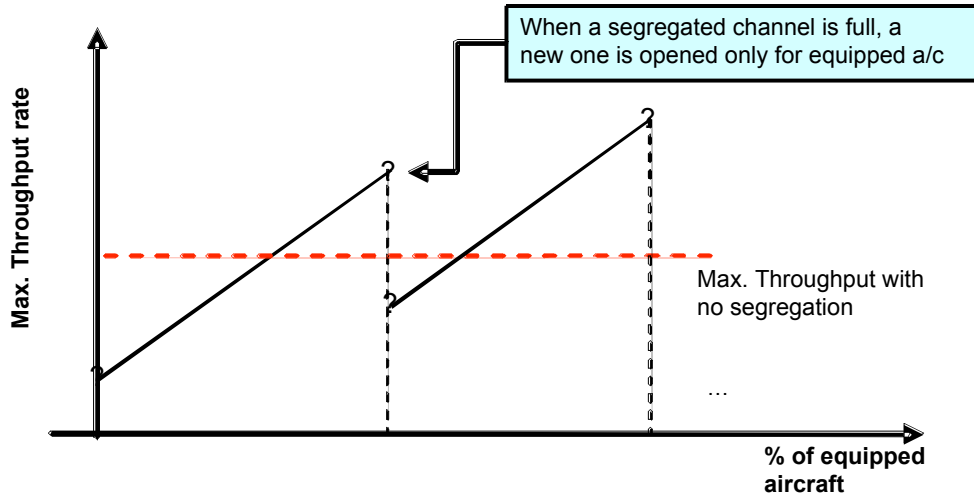

Figure 8-3. Example of Dynamic Segregation. Maximum Throughput as a Function of % of Equipped Aircraft

Dynamic segregation enables taking advantage of the potential for increasing system throughput as the number of equipped aircraft increases, but does not prevent the loss of system throughput when there are few equipped aircraft. In order to maximize throughput, segregation should only be employed if the percentage of equipped aircraft is above a certain “critical mass” that guarantees no throughput losses.

Figure 8-4 illustrates the segregation principles that should be respected to maintain maximum system throughput. No segregation should be employed unless the percentage of equipped aircraft reaches a critical mass: there should be enough equipped aircraft to

fill an entire channel applying the conservative separation minima. If this threshold is reached, a channel should be reserved for the equipped aircraft.

If there are more equipped aircraft and the channel reserved for them is full, a second segregated channel should not be opened until the next threshold that guarantees no throughput losses is reached.

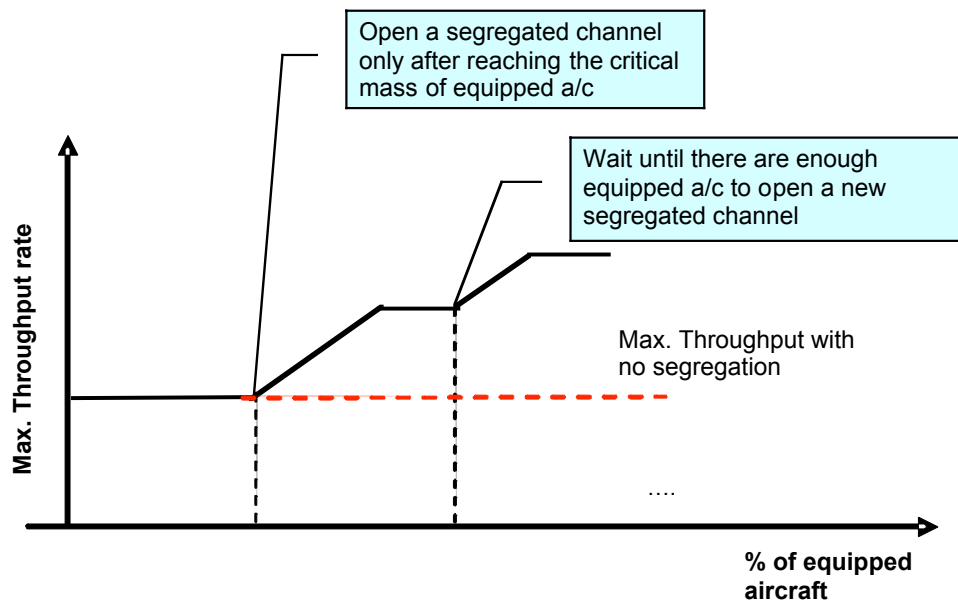

Figure 8-4. Example of Segregation Rules to Maximize Throughput

As shown in Figure 8-4, with appropriate segregation rules to manage channel allocation based on the traffic mix, segregation can be implemented such that the maximum system throughput is never compromised.

Detailed figures with the values of the different thresholds and parameters can be found in Appendices D and E.

8.2 Results

The methodology presented in the previous section was used to study the rules applicable to the implementation of 30/30 separation minima in the NAT under a segregation scheme.

Currently, each of the 55 channels that compose the NAT system (i.e. flight level per track) can accommodate 6 aircraft per hour¹². Therefore, there should be no segregation until we have at least 6 equipped aircraft per hour. Once this threshold is reached, segregation should be implemented, reserving the preferred flight level at the preferred track only for aircraft equipped for 30/30. As a result of the dramatic separation reduction (from 10 minutes --80NM- to 30NM), a second channel can be reserved for equipped aircraft without affecting system throughput even before the first segregated channel is full. In general, as the percentage of equipped aircraft increases and the segregated channels fill, new segregated channels should be opened to keep equipped and non-equipped aircraft separate. Figure 8-5 illustrates this example.

¹² Remember that current longitudinal separation minima are around 10 minutes.

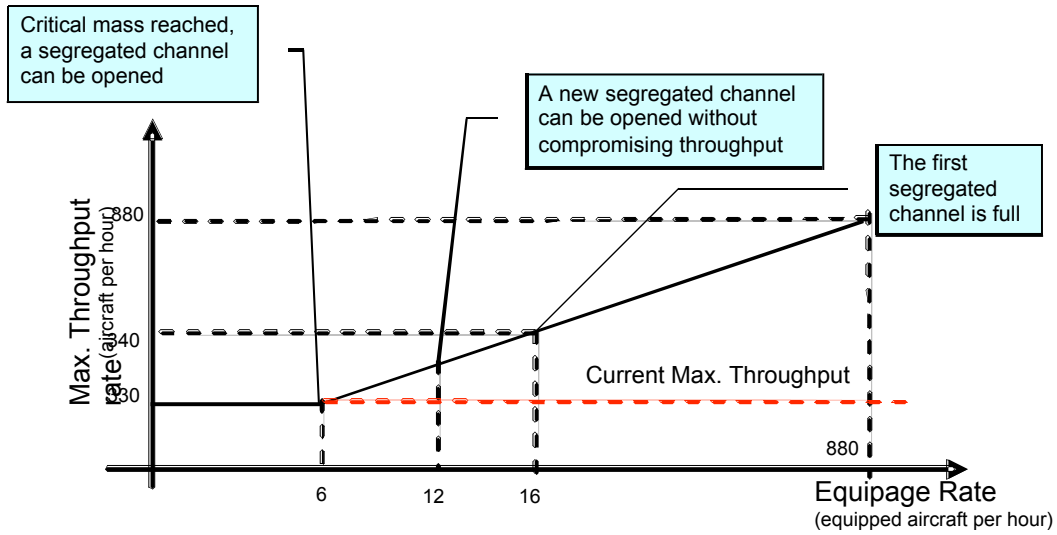

Figure 8-5. Segregation Rules to implement 30NM Longitudinal Separation in the NAT

The implementation of 30/30 minima in the NAT also implies that lateral separation is reduced from 60NM to 30NM. Thus, new tracks can be added to the NAT OTS in between two of the existing tracks, as illustrated in Figure 8-6. Adding new tracks would enable more aircraft to be closer to the jet core, providing additional operational benefits.

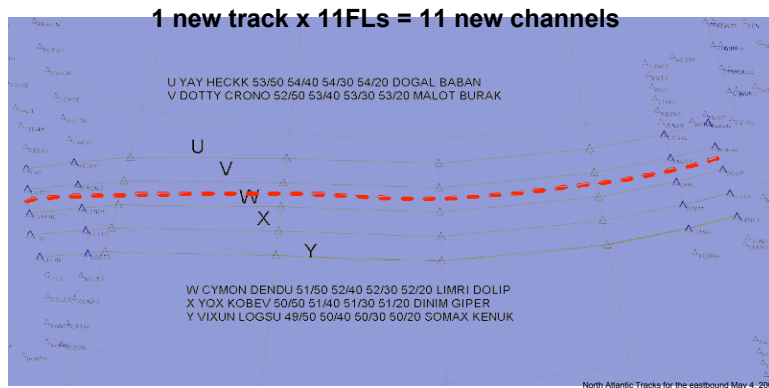

Figure 8-6. Reduction of lateral separation minima enables new tracks to be added to the NAT OTS

As shown in Figure 8-7, if a new track is added between two existing tracks and it is reserved for equipped aircraft, the two adjacent tracks should also be reserved. Since the new track is laterally separated from the old ones only 30NM, only equipped aircraft can be allocated to any three adjacent channels (i.e. the same flight levels of three adjacent tracks). Moreover, as segregated channels are open three at a time, the minimum equipage rate required to allocate equipped aircraft to the new track without compromising system throughput is 12 aircraft per hour (the current throughput rate of the two existing channels that are reserved for equipped aircraft).

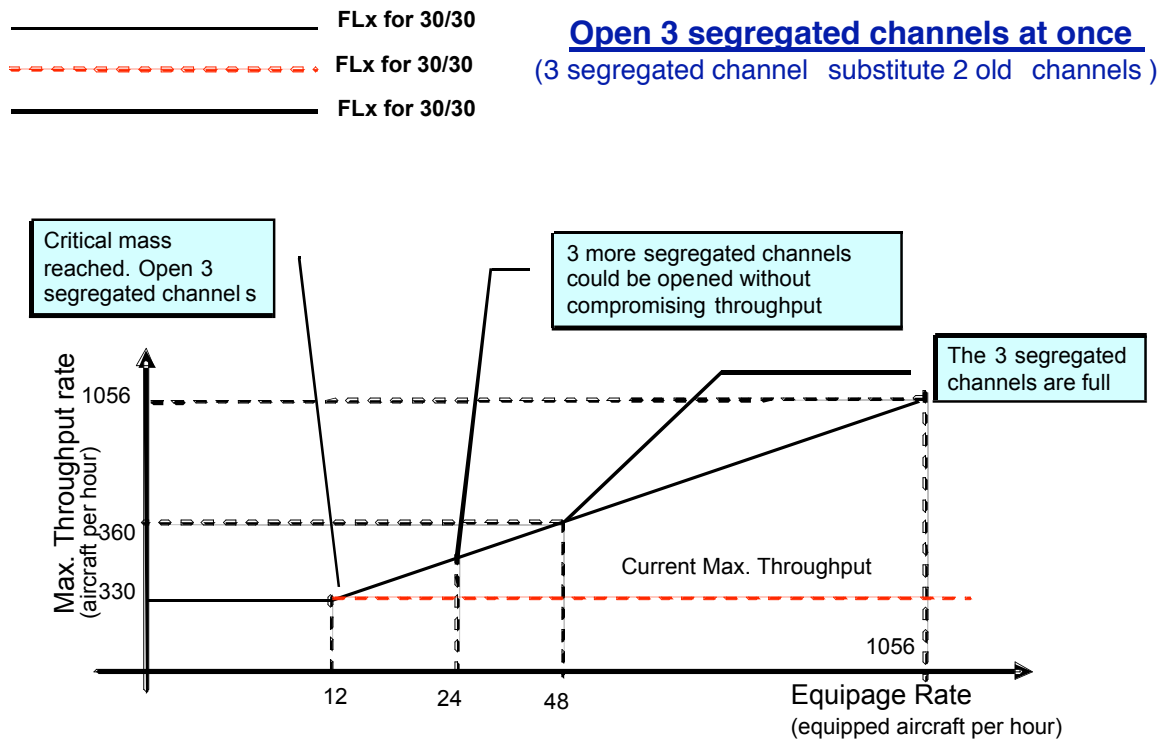

Figure 8-7. Segregation Rules to implement 30NM Lateral Separation in the NAT

The rules and equipage rate thresholds required to implement segregation in the NAT depend on the separation reduction being introduced. For example, if aircraft

equipped with ADS-C (report every 27min), RNP10, and direct controller pilot communications were longitudinally separated 50NM, as occurs in the Pacific ICAO region [39], the previously defined rules would not be directly applicable.

Figure 8-8 illustrates the 50NM example. The critical mass required to reserve one channel for equipped aircraft without compromising throughput remains the same as the previous example: no segregation should be introduced unless we have at least 6 equipped aircraft per hour. However, in the 50NM example, this first segregated channel fills with equipped aircraft (9 per hour) before the minimum equipage rate to open two segregated channels is reached (12 per hour). This means that until this second threshold is reached, equipped aircraft should be allocated to the same channels used for the non-equipped. In Figure 8-8, this region is represented by a flat line because, despite the increase in the percentage of equipped aircraft there is no throughput improvement as they are allocated to non-segregated channels and separated with the conservative separation standards.

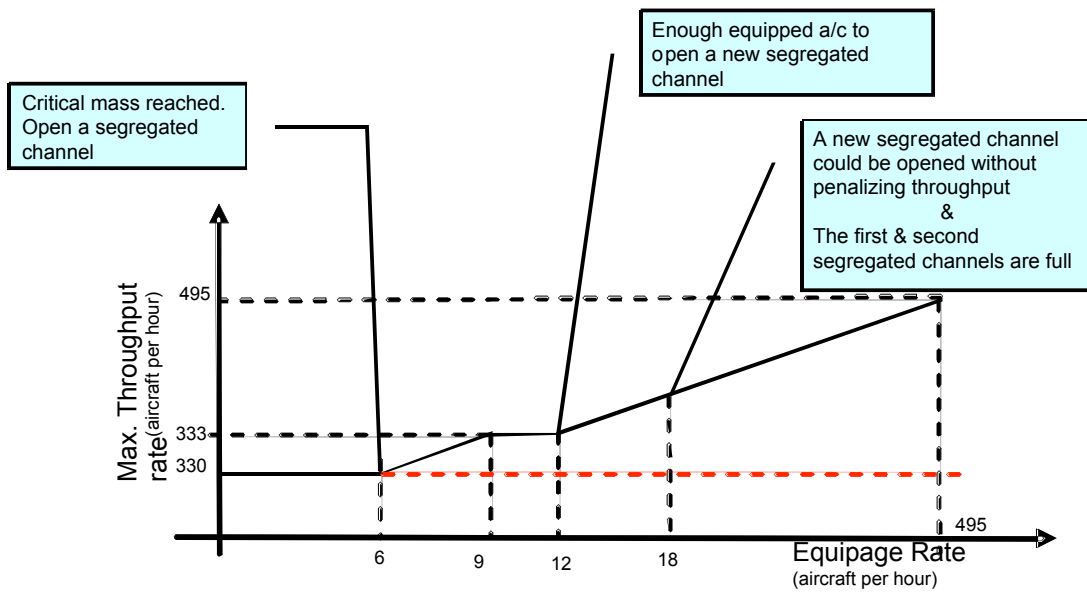

Figure 8-8. Segregation Rules to implement 50NM Longitudinal Separation in the NAT

Finally, if, like in the Pacific region, several reduced separation standards coexisted in the NAT, the rules would become far more complex because they would depend on the equipage rate of both capabilities: the one required to be eligible for 50NM and the one required to be eligible for 30NM. Figure 8-9, as an example of the rule space, illustrates how complex and dynamic these rules can become.

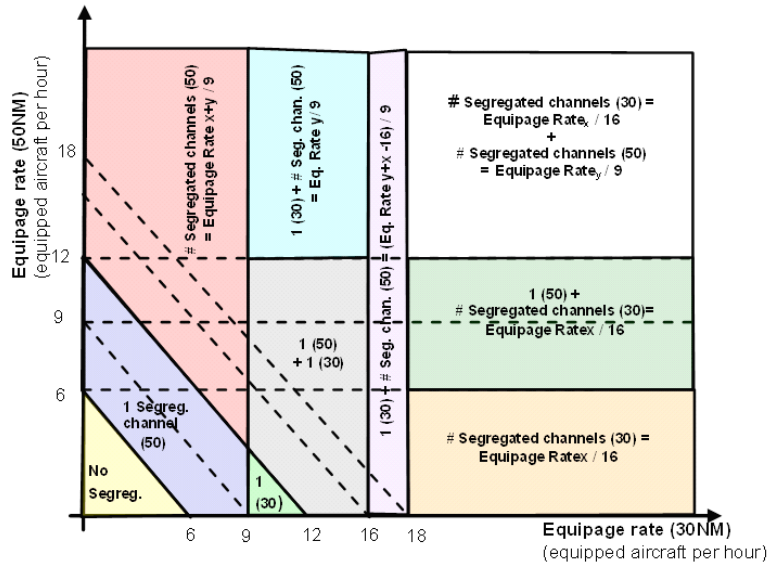

Figure 8-9. Example of Segregation Rules in case of complex separation standards

8.3 Conclusions

The implementation of reduced separation standards in the NAT segregating equipped and non-equipped aircraft should not only be attractive for controllers and users, but should not either compromise system performance. This analysis explored appropriate segregation strategies that guarantee, at the very least, maximum system throughput maintenance. Results suggest that segregation can be applied in the NAT without negatively affecting system throughput if it includes implementation of additional tracks and dynamic segregation that adapts to traffic mix and respects the critical mass required for segregation.

A potential limit for segregation is the level of dynamism that air traffic controllers can accept. From the system throughput perspective, the equipage rate variability determines the level of dynamism required for segregation to be acceptable. From the cognitive perspective, the more dynamism is introduced in the system, the higher

complexity levels are handled by controllers. An appropriate system throughput versus cognitive complexity tradeoff is necessary to ensure the feasibility of segregation. As mentioned, air traffic controllers', users', and system's considerations are not independent dimensions; each of them should be studied in the context of the other two.

9 Conclusions

9.1 Mixed Equipage ATC Procedures

Mixed equipage poses significant barriers to aviation system transformation. However, the majority of the studies on new operating capabilities are conducted under the assumption that all aircraft are equipped. The few studies that incorporate mixed equipage issues suggest that important human factor concerns may arise under this condition. Mixed equipage risks and challenges are recognized but little effort has been devoted to formally understand its implications and to develop an appropriate framework to investigate them. To better understand mixed equipage implications, this thesis proposes and illustrates a multidimensional approach covering controllers, users, and overall air traffic management system performance.

At the controller level, mixed equipage modifies the nature of cognitive processes, increasing complexity and workload. The experiments conducted as part of this research suggest that higher controller error rates occur even at low mixed equipage levels. At the user level, mixed equipage limits the attractiveness of investing in new operating capabilities, and at the system level, mixed equipage might degrade the overall system performance.

In order to combat these effects, mechanisms that minimize costs and maximize benefits for controllers and users during system transition periods are needed. Airspace segregation has the potential to reduce controller cognitive complexity and incentivize equipage adoption. Other potential alternatives are preferential treatment, DSTs, or subsidies. Preferential treatment, however, might result in additional cognitive

complexity for controllers and excessive penalties for the aircraft equipped with lower capabilities.

9.2 Segregation and Reduced Separation Standards in the NAT

The implementation of reduced separation standards in the NAT faces important challenges that need to be addressed to make transition successful. Experimental studies suggest that the coexistence of mixed separation standards leads to higher controller error rates. In addition, controllers to resolve conflicts tend to deviate equipped aircraft from their routes instead of maneuvering non-equipped aircraft. These penalties and the fact that equipped aircraft do not obtain direct operational benefits from their operating capabilities make airlines reluctant to retrofit their fleet.

Segregation can facilitate the transition to reduced separation standards in the NAT. Spatially separating equipped and non-equipped aircraft as well as allocating high-demand airspace to equipped aircraft creates incentives for equipage adoption while decreases cognitive complexity for controllers. Preliminary estimations of the expected incentives in case of segregation in the NAT provide figures of around 4 minutes of flight time reduction.

However, segregation management also requires to correlate resource allocation with the number of equipped aircraft and to guarantee no deterioration of aggregate system performance in order to be successful.

10 References

- [1] Hollinger K.V., Narkus-Kramer M. Expediting an Improved Performance Based NAS: The Rationale for Accelerating Avionics Equipage. American Institute of Aeronautics and Astronautics. 2005.
- [2] Eurocontrol. Cascade Stream 1 Real-Time Simulation. ECC Note No. 404. February 2006.
- [3] Operational Evaluation Coordination Group. Phase I – Operational Evaluation. Cargo Airline Association ADS-B Program/FAA SafeFlight 21 Program. Washington, DC. 2001.
- [4] Laura Major Forest and R. John Hansman. The Future Oceanic ATC Environment: Analysis of Mixed Communication, Navigation, and Surveillance Equipage. Air Traffic Control Quarterly, Vol. 14(2) 117-138 (2006).
- [5] Karain Marais and Annalisa Weigel. Encouraging and Ensuring Successful Technology Transition in Civil Aviation. MIT – Engineering Systems Division. ESD-WP-2006-07. March 2006.
- [6] SESAR Consortium. D2 Air Transport Framework: The Performance Target. DLM-0607-001-02-00a December 2006.
- [7] U.S. Department of Transportation. Federal Aviation Administration. Pilot-Based Spacing and Separation on Approach to Landing: The Effect on Air Traffic Controller Workload and Performance. DOT/FAA/ACT-05/14. December 2005.
- [8] W. S. Pawlak, C. R. Brinton, K. Crouch, and K. M. Lancaster. A framework for the evaluation of air traffic control complexity. In Proceedings of the AIAA Guidance Navigation and Control Conference, San Diego, CA, 1994.
- [9] Endsley, M.R. and Garland D.J. (Eds.) (2000) Situation Awareness Analysis and Measurement. Mahwah, NJ: Lawrence Erlbaum Associates.
- [10] Klein, G., & Klinger, D. (2000). Naturalistic Decision Making. Human Systems IAC GATEWAY, 11 (3), 16-19.
- [11] Rouse, W.B. and Morris N.M. (1986). On looking into the black box: Prospects and limits in the search for mental models. Psychological Bulletin, 100, 349-363.
- [12] Rasmussen, J. 1986. Information processing and human machine interaction. Amsterdam: North-Holland Press.
- [13] Klein, G., Orasanu J., Calderwood R., Zsombok C. Decision Making in Action: Models and Methods. Ablex Publishing Corporation Norwood, New Jersey. 1993.

- [14] Eurocontrol. Airborne Spacing in the Terminal Area: Controller Experiments on Mixed Equipage, Abnormal Situations and Transition. ECC Note No. 24/06. December 2006.
- [15] Mogford R.H. Mental Models and Situation Awareness in Air Traffic Control. *The International Journal of Aviation Psychology*, 7(4), 331-341. 1997.
- [16] Christopher D. Wickens, Justin G. Hollands. *Engineering Psychology and Human Performance*. Third Edition. Prentice-Hall Inc. New Jersey.
- [17] Bainbridge, L. (1987) Ironies of automation. In Rasmussen, J., Duncan, K., and Leplat, J. (Eds) *New Technology and Human Error*. Chichester, Wiley, 271-284.
- [18] Thomas B. Sheridan. *Telerobotics, Automation, and Human Supervisory Control*. The MIT Press. Cambridge August 12, 1992.
- [19] Parasuraman, Sheridan, T. B., & Wickens, C. D. (2000). A model for types and levels of human interaction with automation. *IEEE Transactions on Systems, Man, and Cybernetics. Part A: Systems and Humans*, 30, 286-297.
- [20] ICAO, European and North Atlantic Office. North Atlantic MNPS Airspace. Operations Manual. Edition 2005.
- [21] TP 14371 - Transport Canada Aeronautical Information Manual (TC AIM). Transport Canada Aeronautical Information Manual (TC AIM). Rules Of The Air And Air Traffic Services. APRIL 12th 2007
- [22] ICAO, European and North Atlantic Office. Application of Separation Minima (North Atlantic Region). Version 1.0. 2005
- [23] ICAO, European and North Atlantic Office. Guidance and Information Material Concerning Air Navigation in the North Atlantic Region. Seventh Edition. January 2002.
- [24] Herbert Riehl. Jet Streams of the Atmosphere. Technical Report No. 32. Department of Atmospheric Science. Colorado State University. Fort Collins, Colorado. May 1962
- [25] <http://www.srh.noaa.gov/srh/jetstream/global/jet.htm>
- [26] [http://ww2010.atmos.uiuc.edu/\(Gh\)/guides/mtr/cyc/upa/jet.rxml](http://ww2010.atmos.uiuc.edu/(Gh)/guides/mtr/cyc/upa/jet.rxml)
- [27] http://squall.sfsu.edu/crws/archive/jetstream_archive.html
- [28] <https://pilotweb.nas.faa.gov/qryhtml/nat.html>
- [29] Elmar R. Reiter. The Layer of Maximum Wind. *Journal of the Atmospheric Sciences*. Volume 15, Issue 1 (February 1958), pp. 27-43
- [30] R. M. Endlich and G. S. McLean. The Structure of The Jet Stream Core. Volume 14, Issue 6 (December 1957), pp. 543-552

[31] http://www.iata.org/whatwedo/aircraft_operations/fuel/fuelaction/fuel_conservation.htm

[32] FAA. Oakland Air Route Traffic Control Center (ARTCC). Expansion of Operational Trials for 30 Nautical Mile (nm) Lateral and 30 nm Longitudinal (30/30) Separation throughout Oakland Oceanic Control Area (CTA). Notice posted in 15 Feb 07 edition of FAA Domestic/Intl NOTAM Book

[33] FAA. ENRT-2: Reduced Oceanic Separation. Smart Sheet. Version 8, May 2006

[34] Informal South Pacific ATS Coordination Group (ISPACG). Minutes of the 19th meeting of ISPACG. Agenda Item 4: Future Work Programs: Air Traffic Management. Brisbane, Australia 28th February to 3rd March 2005.

[35] ICAO. Manual on Required Navigation Performance (RNP). Doc 9613-AN/937, Second Edition. 1999.

[36] FANS Interoperability Team. FANS-1/A Operations Manual. Version 4.0. September 2006

[37] David R. Barker, Brennan M Haltli, Charlotte Laqui, Paul Mac Williams, and Kelly L. McKee. Assessment of Terminal RNAV Mixed Equipage. In Proceedings of 23rd Digital Avionics Systems Conference, October 2004, Salt Lake City, Utah.

[38] <http://www.tc.gc.ca/CivilAviation/publications/tp14371/RAC/11-1.htm>

[39] U.S. Department of Transportation. FAA. Order 7110.65R. Air Traffic Control. Feb 2006

Appendix A. Controller Errors: Chi-Square Test

Contingency tables with observed and expected values are included as Tables 1 and 2.

Table 1. Observed total detected and undetected conflicts vs. aircraft's equipage levels

	Undetected Conflicts	Correctly Detected Conflicts
Non equipped & Non equipped	9	89
Non equipped & Equipped	6	106
Equipped & Equipped	1	90

Table 2. Expected total detected and undetected conflicts vs. aircraft's equipage levels

	Undetected Conflicts	Correctly Detected Conflicts
Non equipped & Non equipped	5.21	92.79
Non equipped & Equipped	5.95	106.05
Equipped & Equipped	4.84	86.16

Appendix B. Plots of Estimated Flight Time Means: Entrypoints and Entry Time

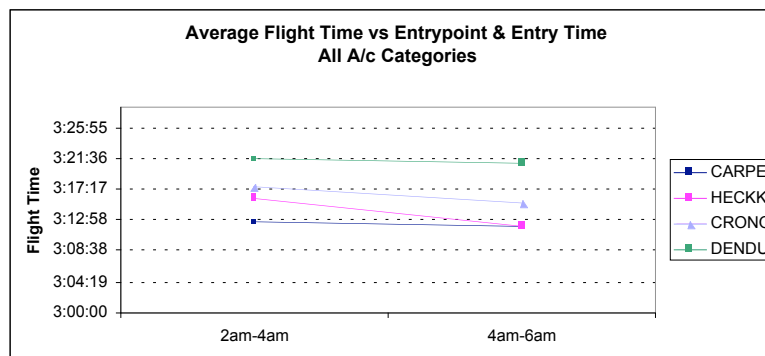
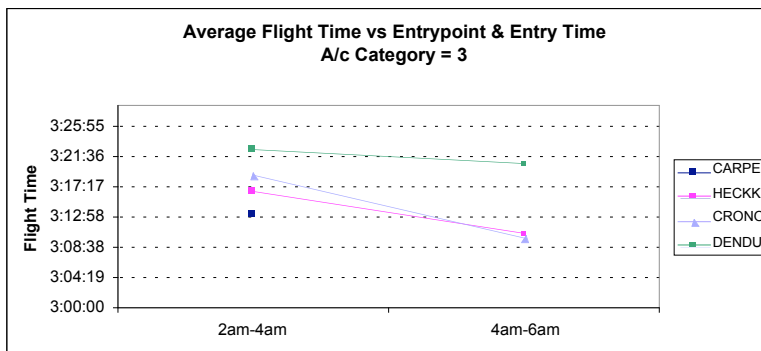
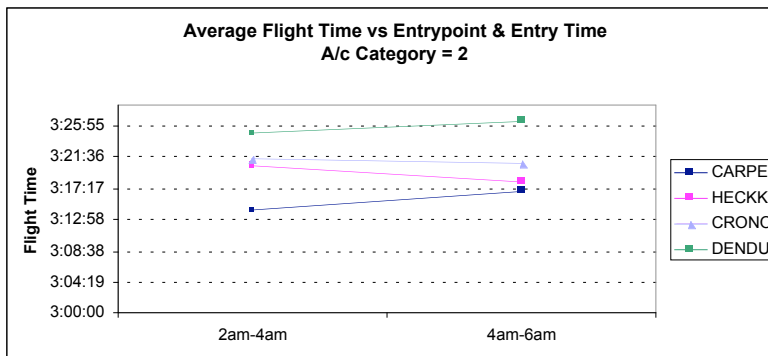
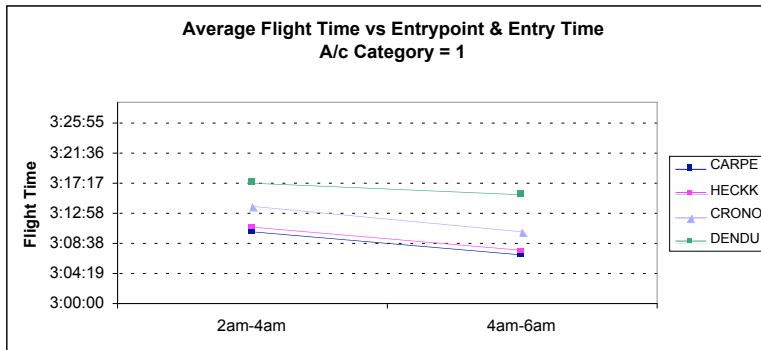

Appendix C. Bonferroni Contrasts of Flight Times

Flight time differences between CARPE and the rest of the entry points were estimated using the Bonferroni method. Because of large differences in the treatment sample sizes, the correction for unequal samples was utilized. Table 1 presents the confidence intervals calculated with $\alpha = 0.05$.

Table 1. Bonferroni contrasts for different entry points and entry times (all aircraft categories)

Entry Time	Flight Time Differences between 2 tracks (mm:ss)		
	CARPE-HECCK	CARPE-CRONO	CARPE-DENDU
From 2am to 4am	[-7:25, 0:35]	[-9:24, -0:34]	[-13:22, -4:22]
From 4am to 6am	[-4:05, 3:48]	[-7:52, 1:00]	[-14:07, -4:52]

Appendix D. Static Segregation: Throughput vs. Equipage Rate

N : Number of channels

S_1 : Separation requirement for non-equipped a/c (i.e. eligible for current separation standards)

D_1 : Maximum throughput rate of N channels with S_1 separation requirement

S_2 : Separation requirement for equipped a/c (i.e. eligible for reduced separation)

C_r : Separation reduction coefficient ($C_r < 1$), $C_r = S_2 / S_1$

D_1/C_r : Maximum throughput rate of N channels with S_2 separation requirement

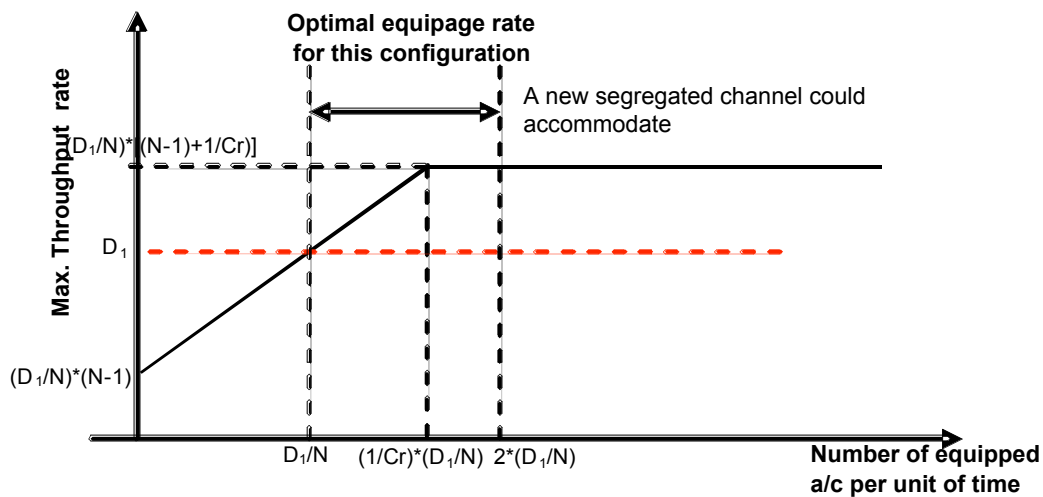

Figure 1. Static Segregation. Example of maximum throughput rate vs equipage rate

Appendix E. Dynamic Segregation: Throughput vs. Equipage Rate

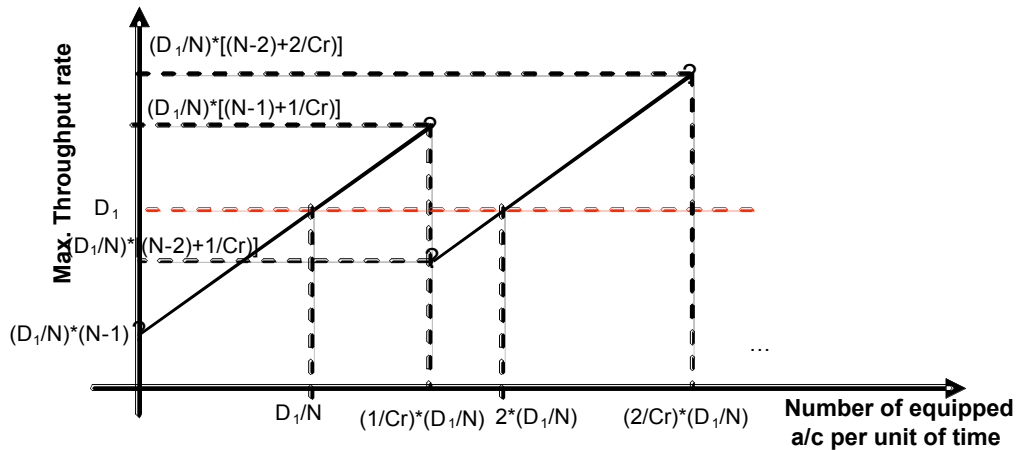

Figure 1. Dynamic Segregation. Example of maximum throughput rate vs. equipage rate

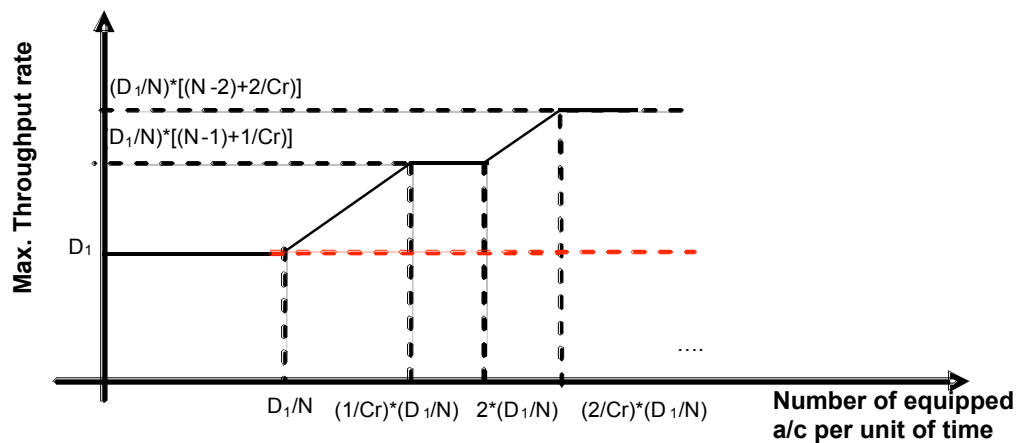

Figure 2. Example of Segregation Rules to Maximize Throughput Rate