

RESEARCH ARTICLE

Application of tank model and quantitative assessment to predict rainfall induced displacement on landslide – Case study on Nawalapitiya landslide, Sri Lanka

A.R.P. Weerasinghe^{1,*}, K.N. Bandara¹ and J. Gunathilake^{2,3}

¹National Building Research Organisation, Jawatta Road, Colombo 05, Sri Lanka.

²Postgraduate Institute of Science, University of Peradeniya, Peradeniya, Sri Lanka.

³Department of Geology, Faculty of Science, University of Peradeniya, Peradeniya, Sri Lanka.

Received: 30/04/2019; Accepted: 27/10/2019

Abstract: Introducing of advance non-structural methodologies has not established widely to reduce the impact from landslide to communities by understanding the behavior of groundwater in a slope. To understand the behavior of groundwater, different types of models can be used to simulate groundwater levels. Among them, a simple tank model can represent a non-linear flow behavior and can get solutions very quickly. Also it can be used for the long-term analysis of the runoff and groundwater table fluctuations. The tank model is based on an analysis of the water balance, a calculation model that follows water flows in and out of the relevant hydrological system in a hillslope. As a modified and advanced version of this tank model, a multi-tank model was used in this study to analyze the groundwater table fluctuations in the slope. Past data from water level gauges installed in B-5, B-6 and B-7 were used to calibrate and simulate the tank model which was used in this study. Heavy rainfall-induced displacement (HRID) and maximum increase in water level (MIWL) were used as two variables to describe the change of displacement and the level of groundwater in the event of heavy rains. HRID and MIWL relationship and the simulated groundwater level from the tank model were used to estimate the calculated heavy rainfall-induced displacement (CHRID) and it is shown a good relationship with the actual rainfall-induced displacement. Therefore, this approach will be very useful for predicting groundwater level and calculating heavy rainfall-induced displacement particular landslide. An early warning system can be developed using this tank model by providing quantitative assessment which gives us more time to avoid risk through appropriate warning and evacuating rather than actions on real time when the active movements of the landslide occurs.

Keywords: Groundwater simulation; Landslide Monitoring; Nawalapitiya Landslide; Rainfall-induced displacement; Tank Model.

INTRODUCTION

The heavy rains caused by monsoonal, convectional and expressional rainfalls in Sri Lanka, are the most prominent meteorological factors that can threaten the stability of a slope. The rainfall-induced displacement affects the equilibrium state of the landslide. In contrast to shallow landslides and debris flows, which mainly affect

the superficial soil layers of the slope and which can be predicted from climatic thresholds, it is difficult to estimate and assess the impact of heavy rainfall on deep landslides due to complex geological and hydrological conditions.

Many known measures are used to reduce the impact of this kind of deep landslides in Sri Lanka. Among them, mitigation and monitoring of landslide, early warning, hazard zonation mapping, public awareness programs can be highlighted. Early warning has been widely used during heavy rainfall event to advise the community on possible landslides in regional, local or specific locations. However, some of the major landslides in Sri Lanka, are installed with costly monitoring instruments, usage of site-specific early warning systems are not very common rather than using them for designing mitigation options. Therefore, necessity of site-specific relabel early warning system to control the risk of a monitored landslide in an economically sensitive location is essential.

As for the characterization of the groundwater system and predicting the groundwater level, physically based numerical models can be used (Yoon *et al.*, 2011). For reliable predictions, however, this approach requires a large amount of accurate data to identify both physical properties of the domain and model parameters when calibrating model simulations (Yoon *et al.*, 2011). Another approach for predicting of groundwater levels uses different black-box models, such as the artificial neural network (Daliakopoulos *et al.*, 2005; Emamgholizadeh *et al.*, 2014; Nayak *et al.*, 2006), to simulate the nonlinear relationship between input and output series. Otherwise, there were no physical means in the parameters used in these models.

Sugawara and Funiyuki (1956) was introduced a simple tank model which is a conceptual rainfall-runoff model. As it can represent a non-linear flow behavior and can get solutions very quickly, it can be used for long-term analysis of runoff and groundwater levels. The tank model is based on the analysis of the water balance, a calculation model that tracks water flows into and out of the relevant hydrological system. This model can be used to simulate groundwater and further to issue an early warning.

*Corresponding Author's Email: ranjan.weerasinghe@gmail.com

 <https://orcid.org/0000-0001-5666-1084>



STUDY AREA

Nawalapitiya landslide is located at the 15 km post along Nawalapitiya-Kandy road and is about 1 km from the Nawalapitiya town in Kandy district. Sections of Kandy-Nawalapitiya main road, Colombo-Badulla railway line, an abandoned railway line and concrete paved access road are positioned across this landslide coupled with few houses falling within the sliding area (Figure 1). The study area lies within the coordinates of 7.062180 N, 80.536769 E and 7.061625 N, 80.538004 E in WGS 84. The upper part of this slide is having a gentle slope about 20° to 30° up to main road level and the lower part is having a steeper slope about 40° to 50° beyond the road level up to Mahaweli River which is at the toe. Long term observations show the Nawalapitiya landslide is subjected to overall creep movement (Lakmali *et al.*, 2018). This landslide is composed of a colluvium layer, a fill layer and a residual layer besides underlying bedrock. According to the borehole data, maximum of 13 m depth colluvium layer observed and about 7 m thick residual layer is present underneath the colluvium (Lakmali *et al.*,

2018). Fill materials which were used for the construction of the railway track and main road, are present at the site location. The maximum depth to the bedrock is 20.43 m at the B-1 and the bedrock lithologies are Khondalite, Marble, Hornblende Biotite Gneiss, Quartzofeldspathic Gneiss and Garnet Biotite Gneiss (Lakmali *et al.*, 2018).

This Landslide is composed of several sliding blocks which has sliding direction of South-East and the length of the slope is approximately 110 m from the crown to toe and the maximum width of the sliding body is about 60 m (Figure 1 and Figure 2) with a depth of approximately 12 m to the slip surface.

In association with Road Development Authority (RDA), Japanese International Cooperation Agency (JICA) and National Building Research Organisation (NBRO) has installed monitoring devices in the Nawalapitiya landslide area for monitoring the displacements (Table 1). Three main sliding blocks were identified based on their differential displacement (Figure 1). Block-C is located at

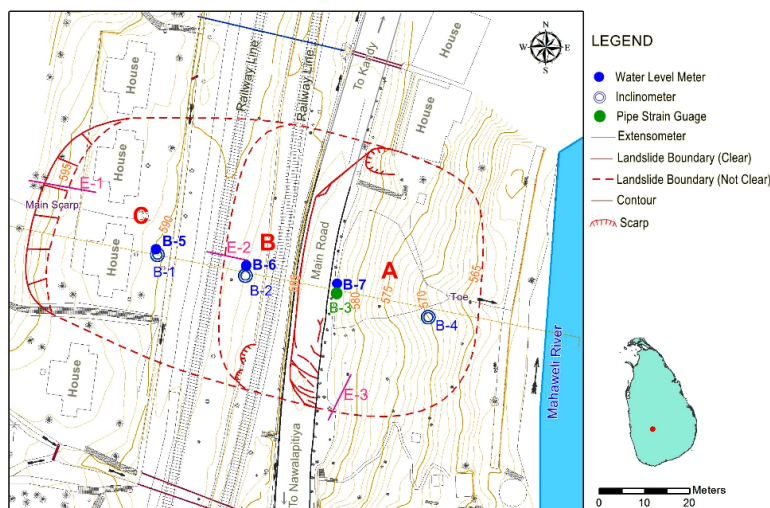

Figure 1: Plan view of the Nawalapitiya Landslide.

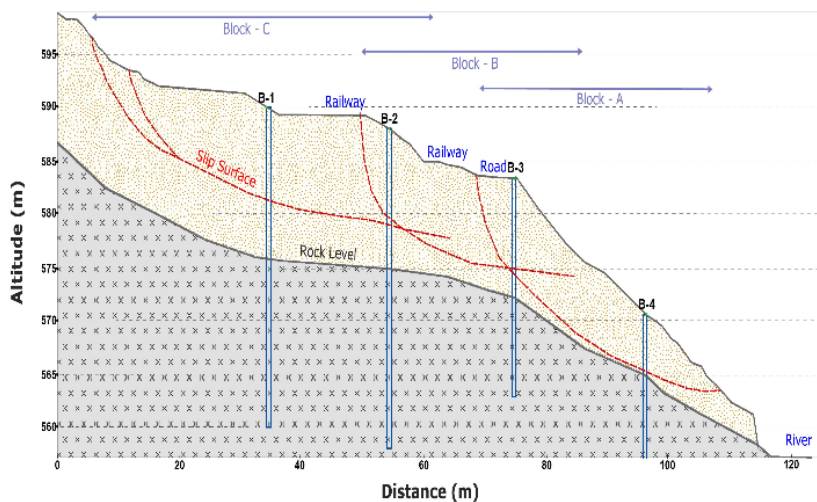

Figure 2: Cross Section along the axis of the Nawalapitiya Landslide.

Table 1: Monitoring equipment installed at Nawalapitiya landslide.

Monitoring Equipment	Sliding Block			Monitoring Frequency
	Block A	Block B	Block C	
Extensometer	E-3	E-2	E-1	Once an hour (Automatic)
Inclinometer	B-4	B-2	B-1	Twice a month in rainy season and once a month in dry season (Manual)
Pipe Strain Gauge	B-3			Once an hour (Automatic)
Groundwater Level Gauge	B-7	B-6	B-5	Once an hour (Automatic)

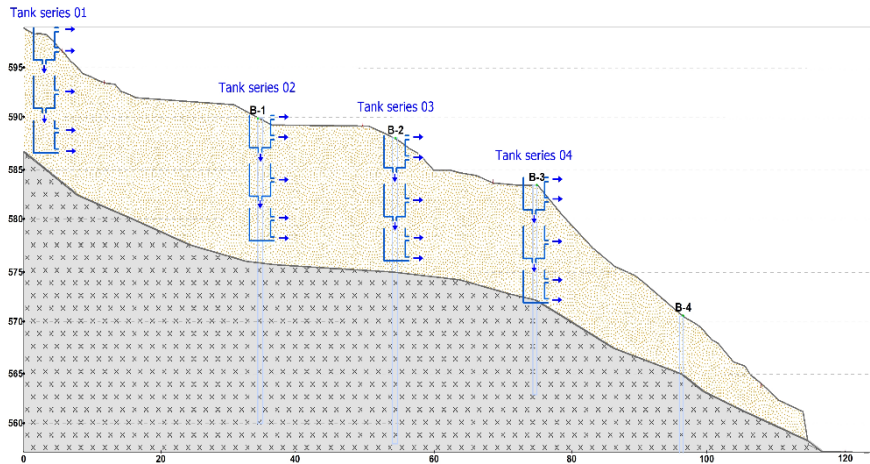

Figure 3: Multi-tank model system used for Nawalapitiya landslide.

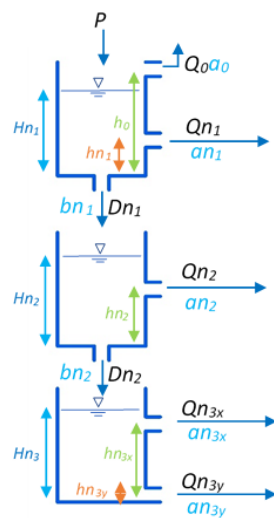

Figure 4: Detailed structure of the n^{th} tank series (Modified after Sugawara 1974).

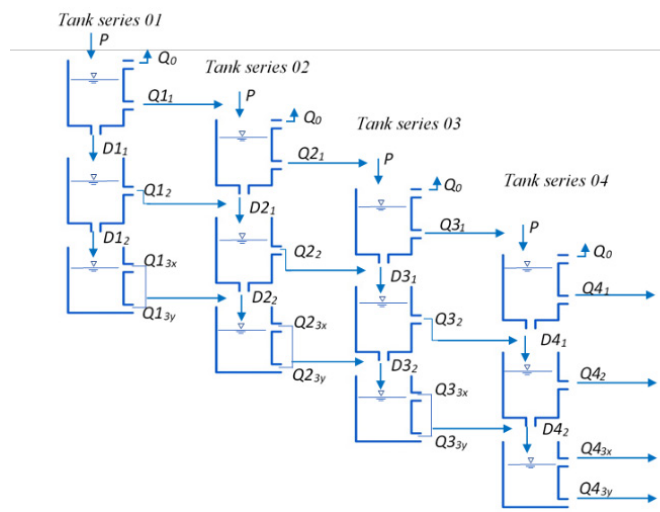

Figure 5: Assumed flow patterns in a multi-tank model for Nawalapitiya Landslide.

the upper part of the slope and covered the sliding mass from the crown to the middle. The displacements are monitored by extensometer E-1 and inclinometer B-1. Block-B occupies at the middle part and the displacements are monitored by extensometer E-2 and inclinometer B-2. Block-A is located at the toe area where the highest slope angle can be observed. The displacements are monitored by extensometer E-3, pipe strain gauge B-3 and inclinometer B-4.

METHODOLOGY

The multi-tank analytical model which is an advance derived model of the tank model introduced by Kenji et al.

(2008), is used to simulate the rainfall infiltration in this study. Multi-tank model used at Nawalapitiya landslide is composed of four vertical series and each series contains three tanks (Figure 3). The first tank is used to simulate the net runoff of rainfall with evaporation from the ground surface and the infiltration into the sliding mass that corresponds to the side outlets and the bottom outlet separately. The second tank simulates the underground percolating and the intermediate discharge flow. The third tank simulates the sub base flow and base flow, as the bottom tank in the series. Detailed groundwater and surface water flow paths of this tank model are illustrated

Table 2: Description of parameters of the tank model where ‘n’ is tank series number.

No	Parameter	Description	Dimension
1	P	Precipitation	mm/day
2	Q_0	Evaporation	mm/day
3	Qn_1	Surface discharge	mm/day
4	Qn_2	Intermediate discharge	mm/day
5	Qn_{3x}	Sub-base discharge	mm/day
6	Qn_{3y}	Base discharge	mm/day
7	Dn_1	Surface Infiltration	mm/day
8	Dn_2	Subsurface percolation	mm/day
9	a_0	Evaporation coefficient	-
10	an_1	Surface discharge coefficient	-
11	an_2	Intermediate discharge coefficient	-
12	an_{3x}	Sub-base discharge coefficient	-
13	an_{3y}	Base discharge coefficient	-
14	bn_1	Surface Infiltration coefficient	-
15	bn_2	Subsurface percolation coefficient	-
16	Hn_1	Water storage height of first tank	mm
17	Hn_2	Water storage height of second tank	mm
18	Hn_3	Water storage height of third tank	mm
19	h_0	Height of the evaporation outlet of first tank	mm
20	hn_1	Height of the surface discharge outlet of first tank	mm
21	hn_2	Height of the intermediate discharge outlet of second tank	mm
22	hn_{3x}	Height of the sub-base discharge outlet of third tank	mm
23	hn_{3y}	Height of the base discharge outlet of third tank	mm

in Figure 4 and Figure 5 respectively and the parameters used in this tank model are tabulated in Table 2.

For the multi-tank model used in this studied area, following modified equations were used for calibrating and simulating of the tank model which were introduced by Sugawara (1974), where ‘n’ is tank series number.

$$\begin{aligned}
 & \square \quad Q_0(t) = \quad \quad \quad n=1,2,3,4 \\
 & \square \quad Qn_1(t) = \quad \quad \quad n=1,2,3,4 \\
 & \square \quad Qn_2(t) = \quad \quad \quad n=1,2,3,4 \\
 & \square \quad Qn_{3x}(t) = \quad \quad \quad n=1,2,3,4 \\
 & \square \quad Qn_{3y}(t) = \quad \quad \quad n=1,2,3,4 \\
 \\
 & \square \quad Dn_1(t) = bn_1 Hn_1(t) \quad \quad \quad n=1,2,3,4 \\
 & \square \quad Dn_2(t) = bn_2 Hn_2(t) \quad \quad \quad n=1,2,3,4 \\
 \\
 & \square \quad dH1_1/dt = P(t) - Q1_1(t) - Q_0 - D1_1(t) \\
 & \square \quad dH1_2/dt = D1_1(t) - Q1_2(t) - D1_2(t) \\
 & \square \quad dH1_3/dt = D1_2(t) - Q1_{3x}(t) - Q1_{3y}(t) \\
 & \square \quad dH2_1/dt = P(t) - Q2_1(t) - Q_0 - D2_1(t) + Q1_1(t) \\
 & \square \quad dH2_2/dt = D2_1(t) - Q2_2(t) - D2_2(t) + Q1_2(t) \\
 & \square \quad dH2_3/dt = D2_2(t) - Q2_{3x}(t) - Q2_{3y}(t) + Q1_{3x}(t) + Q1_{3y}(t) \\
 & \square \quad dH3_1/dt = P(t) - Q3_1(t) - Q_0 - D3_1(t) + Q2_1(t) \\
 & \square \quad dH3_2/dt = D3_1(t) - Q3_2(t) - D3_2(t) + Q2_2(t) \\
 & \square \quad dH3_3/dt = D3_2(t) - Q3_{3x}(t) - Q3_{3y}(t) + Q2_{3x}(t) + Q2_{3y}(t) \\
 & \square \quad dH4_1/dt = P(t) - Q4_1(t) - Q_0 - D4_1(t) + Q3_1(t) \\
 & \square \quad dH4_2/dt = D4_1(t) - Q4_2(t) - D4_2(t) + Q3_2(t) \\
 & \square \quad dH4_3/dt = D4_2(t) - Q4_{3x}(t) - Q4_{3y}(t) + Q3_{3x}(t) + Q3_{3y}(t)
 \end{aligned}$$

Tank Model Calibration

Trial and error based automatic calibration method introduced by Sugawara (1979), was used for the calibration of the tank model. The daily rainfall taken from the Pussallawa rain gauge and groundwater levels taken from the automatic water level gauges at B-5, B-6 and B-7 boreholes were used as input parameters. Rainfall data and groundwater level data from November 2014 to November 2015 were used to calibrate the tank model and then groundwater level data was simulated according to the rainfall from November 2015 to November 2016. Microsoft Excel 2016 with Macros powered by visual basic for applications (VBA) was used for calculations.

RESULTS AND DISCUSSION

In order to explain the role of groundwater in the failure activity of Nawalapitiya landslide, water level data in borewells B-5, B-6 and B-7 were studied with respect to the extensometer data of E-1, E-2 and E-3. It is found that the occurrence of heavy rainfall is associated with significant variations in groundwater level (Figure 6).

Heavy rainfall-induced impacts on the sliding mass are obvious and can be discerned from the landslide displacement. This displacement after a heavy rainstorm can be identified as a heavy rainfall-induced displacement (HRID) because it is considered to be the result of the change in groundwater level due to high-intensity rainfall mostly over 40 mm per hour. Since the above results indicate that there is a relationship between groundwater

variation and displacement of the sliding mass, quantitative analysis has been performed. Two variables were given to describe the change of displacement and the level of groundwater in the event of heavy rains. The first is the displacement induced by heavy rainfall as described above. It is defined as the sum of the displacement at an active extensometer location, which is accumulated from the beginning of the change in water level in the corresponding borehole after a rainstorm until the displacement is stable or negative in value. The second variable is the maximum increase in water level (MIWL), which is defined as the difference between the highest water level caused by heavy rainfall and the average normal water level in the borehole. It serves as a measure to evaluate the effects of heavy rains on the status of groundwater (Hong et al., 2005).

HIRD and MIWL values are taken from Extensometer data and Water Level Gauge data respectively. With the data collected from November 2014 to October 2017, a positive correlation was found between MIWL and HRID. The approximate linear relationships and correlation coefficients in Figure 7 illustrate this point. It can be concluded that the HRID of the Nawalapitiya landslide is related to the variation of the water level. For each block of landslide, a linear relationship between HIRD and MIWL was resulted as follows.

- Block C: $MIWL(B-5) = 0.8912 \times HRID(E-1) + 1.3005$
- Block B: $MIWL(B-6) = 2.0131 \times HRID(E-2) + 0.6892$

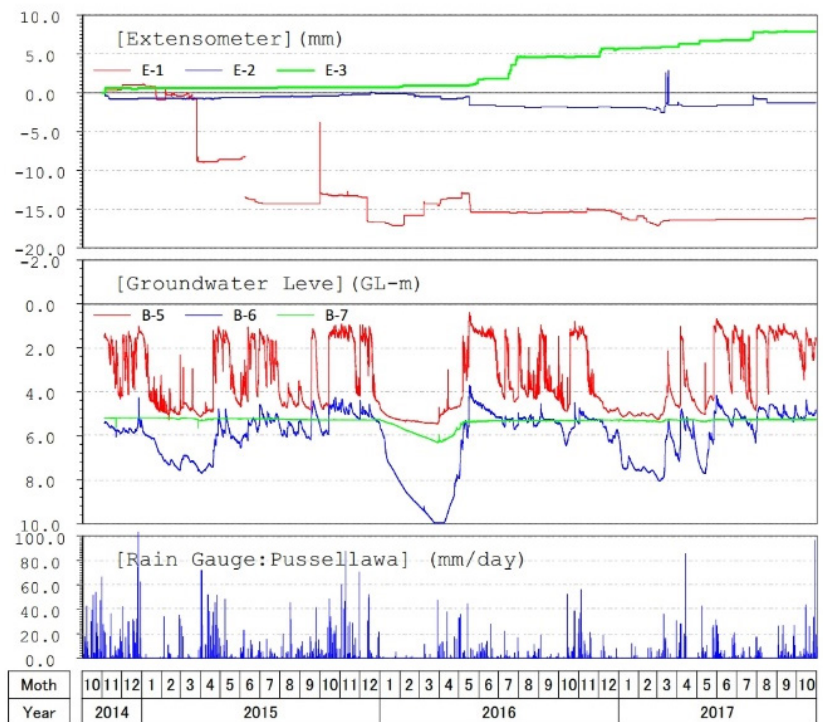

Figure 6: Graphs of extensometer and water level data with respect the rainfall at Nawalapitiya landslide.

- Block A: $MIWL(B-7) = 0.6667 \times HRID(E-3) + 0.3$

Establishing Tank Model for Groundwater Level Simulation

The fluctuation of the groundwater table in the area can be calculated with the aid of rainfall by setting up a tank model. There is a time gap between the occurrence of heavy rainfall and the subsequent change in water level and land displacement. Therefore, it can be assumed that

if the change of water level is calculated in advance, the heavy rainfall-induced displacement of the sliding mass can be estimated. Thus, the effect of heavy rainfall on the landslide of Nawalapitiya can be evaluated in terms of landslide displacement.

For the tank model, 42 parameters were calculated through automatic calibration method. These parameters are unique to this landslide (Table 3) where the observed and simulated groundwater levels are shown in Figure 8.

Table 3: Calculated parameters of the tank model.

Tank Series 01		Tank Series 02		Tank Series 03		Tank Series 04	
$a1_1$	0.074	$a2_1$	0.022	$a3_1$	0.001	$a4_1$	0.909
$a1_2$	0.219	$a2_2$	0.02	$a3_2$	0.002	$a4_2$	0.904
$a1_{3x}$	0.9	$a2_{3x}$	0.07	$a3_{3x}$	0.008	$a4_{3x}$	0.9
$a1_{3y}$	0.825	$a2_{3y}$	0.01	$a3_{3y}$	0.093	$a4_{3y}$	0.999
$b1_1$	0.88	$b2_1$	0.9	$b3_1$	0.909	$b4_1$	0.001
$b1_2$	0.927	$b2_2$	0.509	$b3_2$	0.808	$b4_2$	0.001
$h1_1$	0.218	$h2_1$	0.209	$h3_1$	0.819	$h4_1$	5
$h1_2$	0.191	$h2_2$	0.215	$h3_2$	1.009	$h4_2$	2
$h1_{3x}$	0.2	$h2_{3x}$	0.2	$h3_{3x}$	0.2	$h4_{3x}$	5
$h1_{3y}$	0.2	$h2_{3y}$	0.98	$h3_{3y}$	2.009	$h4_{3y}$	2
$a0$	30	$h0$	1.2				

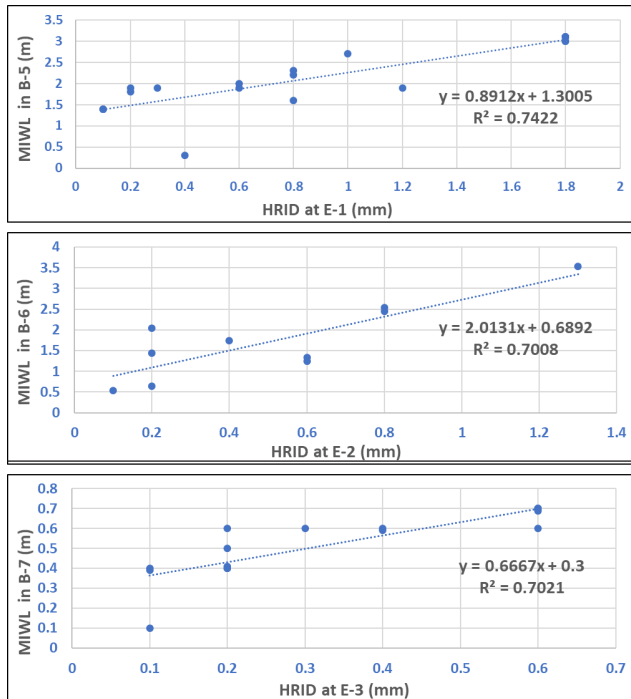

Figure 7: Relationship between the Heavy rainfall induced displacements (HRID) and the maximum increase in water level (MIWL).

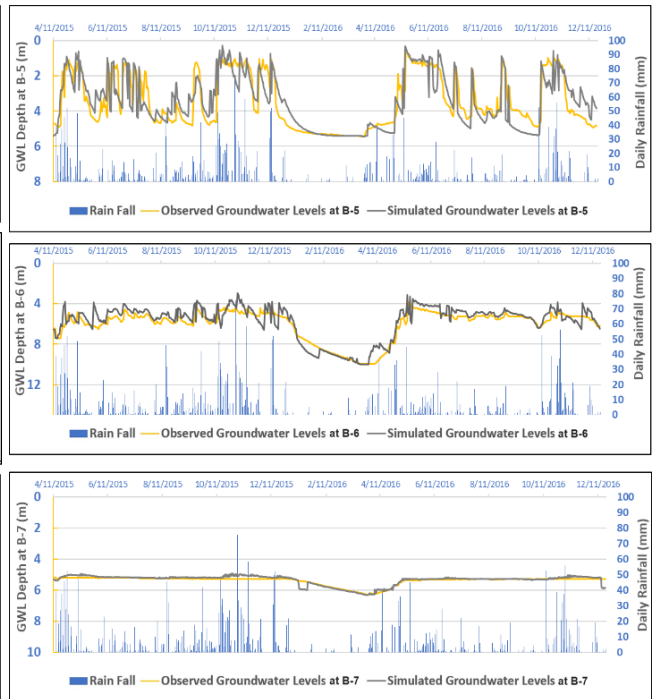

Figure 8: Comparison of observed and simulated groundwater levels (A: groundwater levels at B-5; B: groundwater levels at B-6; C: groundwater levels at B-7).

Assessing the Influence of Heavy Rainfall on the Nawalapitiya Landslide

Based on these results, the heavy rainfall-induced effects on the activity of a landslide can be assessed and predicted. The following event was chosen to demonstrate the application of this method. A total of 101 mm of rainfall was produced during this event from 8th to 14th, May 2016. This rainfall started on 8th May at night and extended to 14th May with the maximum daily rainfall of 47 mm recorded on 13th May. In this study, daily precipitation was used to explain the method. Figure 9 shows the daily extensometer displacements at E-1, E-2 and E-3 and daily water level fluctuations at B-5, B-6 and B-7 due to the rainstorm during the event. In this rainstorm, the peak rainfall occurred on 13th May and the peak groundwater level appeared after three days later which was on; 16th May 2016. While groundwater reaches peak level, the displacements of each block started to occur and became temporally stable after groundwater reducing from the peak level. Therefore, the occurrence in the displacement can be identified in advance if the groundwater level is known after a rainstorm.

Accordingly, corresponding to the precipitation before a given time during the storm, the rainfall-induced maximum level in groundwater in the respective boreholes can be calculated from the tank model. With reference to the approximate relation between MIWL and HRID, the possible displacements induced by rainfall at the sites of E-1, E-2 and E-3 can then be estimated. The effect of heavy rainfall on the landslide can be expressed as the calculated heavy rainfall-induced displacement abbreviated as CHRID. According to the CHRID values obtained during and at the end of the rainstorm, it is possible to evaluate and understand the influence of the rainstorm on the respective sliding blocks before the delayed increase in water pressure following infiltration from rainfall, so that timely warnings or advisories and appropriate measures could be carried out to let residents leave hazardous areas or simply to create a higher state of awareness. CHRID were calculated from applying the MIWL and HRID relationship to the simulated water level from the tank model.

Figure 10 shows the rainfall-induced actual water level recorded in each borehole and simulated water level from the tank model for each borehole while Figure 11 shows the actual displacement recorded in each extensometer and the

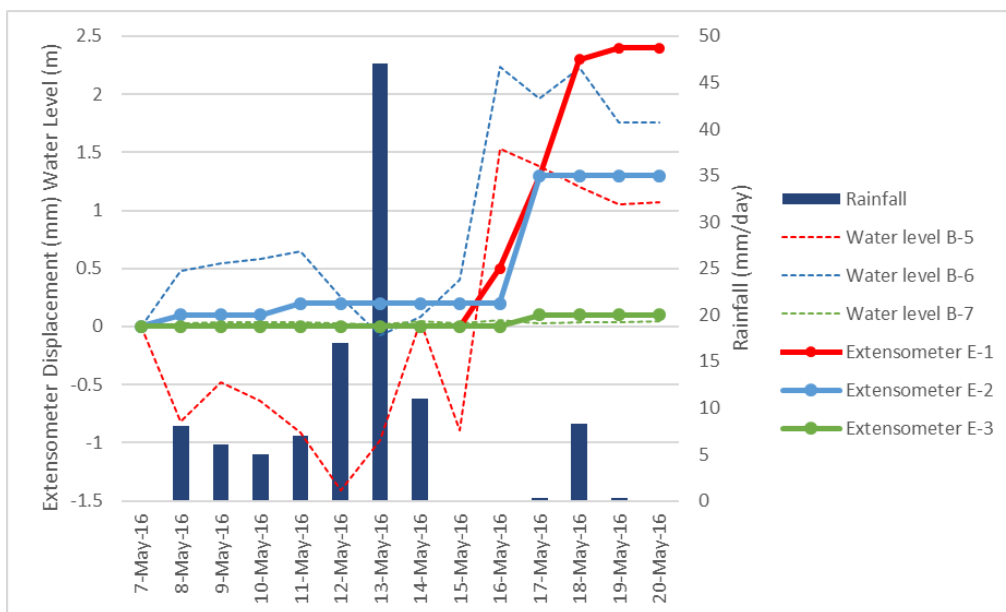

Figure 9: Extensometer displacement and water level fluctuation during the rainstorm 8th to 14th May 2016.

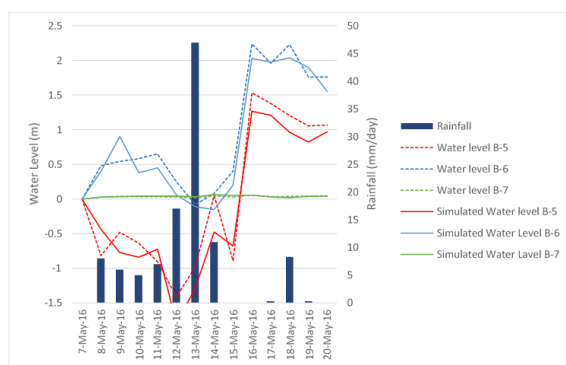

Figure 10: Observed and simulated water level fluctuation during the rainstorm 8th to 14th of May 2016.

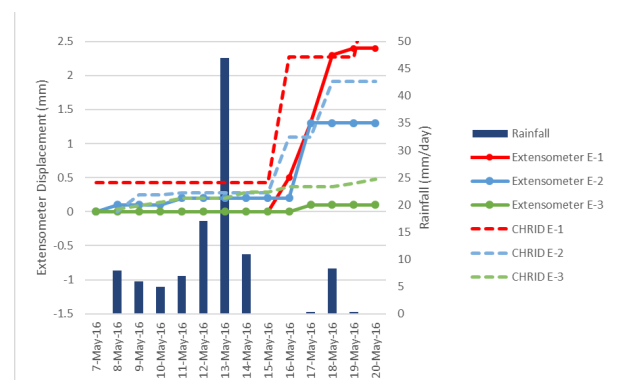

Figure 11: Observed and calculated Extensometer displacement during the rainstorm 8th to 14th of May 2016.

calculated heavy rainfall-induced displacement (CHRID) for each extensometer during the rainstorm 8th May to 14th May 2016. According to these graphs showing in Figure 10 and Figure 11, displacement of each block and groundwater level in each borehole can be predicted for a rainstorm in advance. Therefore, the warning and evacuating people from landslides hazard can be easily done since this method of predicting groundwater and displacement gives us more time to warn and evacuate rather than action on real-time when the activation of displacements of the landslide.

CONCLUSIONS

Based on the analysis, the following conclusions can be made:

- (i) The relationship between the displacements and the increase of water levels indicates that the activity of sliding mass is correlated with the variation of the groundwater state. It provides a criterion to measure the influence of heavy rainfall on the activity of a landslide.
- (ii) By combining the predicted results with the relationship between displacements and the change in water level, the displacements of a sliding mass can be reckoned and the influence of heavy rainfall on the slope can be appraised as a numerical value of displacement. This means that the influence of the same rainfall on the sliding bodies can be measured by the identical measurement unit. And the CHRID can act as a precursor of the landslide response to heavy rainfall.
- (iii) This method is expected to be used as a reference to measure the extent of influence of heavy rainfall on the activity of a landslide before it is reactivated by increased groundwater pressure following rainfall.
- (iv) An early warning system can be developed by use of this tank model by predicting the groundwater level fluctuation induced by the heavy rainfall, which gives us time of about more hours, to warn and evacuate rather than action on real-time when the activation of displacement of the landslide.

REFERENCES

- Daliakopoulos, I.N., Coulibaly, P. and Tsanis, I.K. (2005). Groundwater level forecasting using artificial neural networks. *Journal of Hydrology*, **309**(1): 229-240.
- Emamgholizadeh, S., Moslemi, K. and Karami, G. (2014). Prediction the groundwater level of bastam plain (Iran) by artificial neural network (ANN) and adaptive neuro-fuzzy inference system (ANFIS). *Water resources management*, **28**(15): 5433-5446.
- Hong, Y., Hiura, H., SFhino, K., Sassa, K. and Fukuoka, H. (2005). Quantitative assessment on the influence of heavy rainfall on the crystalline schist landslide by monitoring system-case study on Zentoku landslide, Japan. *Landslides*, **2**(1): 31-41.
- Lakmali, D.G.E.D., Palamakubure, L. and Bandara, K.N. (2018). Characterization of Nawalapitiya landslide, in the Kandy District. *Proceedings of National Buildings Research Organisation Symposium 2018*, 15-25.
- Kenji, T., Yuzo, O., Xiong, J. and Tomofumi, K. (2008). Tank model and its application to predicting groundwater table in slope. *Journal of Rock Mechanics and Engineering*, **27**(12): 2501-2508.
- Nayak, P.C., Rao, Y.S. and Sudheer, K.P. (2006). Groundwater level forecasting in a shallow aquifer using artificial neural network approach. *Water Resources Management*, **20**(1): 77-90.
- Sugawara M, Funiyuki M. (1956). A Method of Revision of the River Discharge by Means of a Rainfall Model. *Collection of Research Papers about Forecasting Hydrologic variables*: 14-18.
- Sugawara, M. (1974). Tank model and its application to Bird Creek, Wollombi Brook, Bikin River, Kitsu River, Sanaga River and Nam Mune. *Research Notes of the National Research Center for Disaster Prevention*, **11**: 1-64.
- Sugawara, M. (1979). Automatic calibration of the tank model/L'étalonnage automatique d'un modèle à cisterne. *Hydrological Sciences Journal*, **24**(3): 375-388.
- Yoon, H., Jun, S.C., Hyun, Y., Bae, G.O. and Lee, K.K. (2011). A comparative study of artificial neural networks and support vector machines for predicting groundwater levels in a coastal aquifer. *Journal of Hydrology*, **396**(1): 128-138.