

Locality in A-movement

by

Martha Jo McGinnis

B.A. Linguistics and English
University of Toronto, 1992

M.A. Linguistics
University of Toronto, 1993

Submitted to the Department of Linguistics and Philosophy
in Partial Fulfillment of the Requirements for the Degree of

Doctor of Philosophy in Linguistics
at the
Massachusetts Institute of Technology

September 1998

©1998 Martha Jo McGinnis. All rights reserved.

The author hereby grants to MIT permission to reproduce and to distribute publicly
paper and electronic copies of this thesis document in whole or in part.

Signature of Author: _____
Department of Linguistics and Philosophy
September 9, 1998

Certified by: _____
Alec Marantz
Professor of Linguistics
Thesis Supervisor

Accepted by: _____
Michael Kenstowicz
Professor of Linguistics
Chair of the Linguistics Program

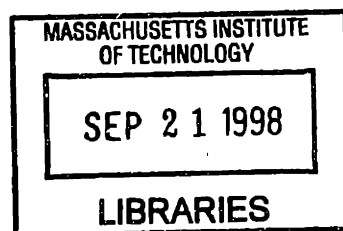

ARCHIVES

Locality in A-Movement

by

Martha Jo McGinnis

Submitted to the Department of Linguistics and Philosophy
on September 9, 1998 in Partial Fulfillment of the
Requirements for the Degree of Doctor of Philosophy in
Linguistics

ABSTRACT

In this dissertation, I demonstrate that the feature-based Attract theory of syntactic movement solves several empirical challenges for Relativized Minimality, while incorporating its key insights. Chapter 1 introduces the theory of phrase structure, syntactic movement, and abstract Case to be adopted throughout the dissertation. This chapter also lays out a cross-linguistic typology of possibilities for A-movement to the subject position.

Chapter 2 concerns cases of advancing, where the argument generated highest is attracted by the feature (EPP) driving movement to the subject position. Here locality interacts with a condition (Case Identification) preventing an argument from “pied-piping” to check EPP if it checks Case elsewhere. In some instances, advancing is forced jointly by locality and Case Identification. Given two equally local arguments, Case Identification determines which can be attracted to the subject position. However, newly identified “superraising” violations support the view that locality is respected even if the highest argument has already checked Case.

In the first part of Chapter 3, I argue for the central empirical proposal of this dissertation, Lethal Ambiguity: an anaphoric dependency cannot be established between two specifiers of the same head. I contend that one argument can A-scramble past another only by entering, or leapfrogging through, a multiple-specifier configuration with it. In either case, no anaphoric dependency can be established between the two arguments. In the second part of Chapter 3, I present cases of leapfrogging in A-movement to the subject position, also subject to Lethal Ambiguity.

Chapter 4 extends the empirical coverage of Lethal Ambiguity to answer a long-standing question from the literature—namely, why anaphoric clitics cannot be object clitics. I argue that Lethal Ambiguity rules out the object clitic derivation for anaphors because an anaphoric object checks Case in a multiple-specifier configuration with the would-be antecedent. I adopt a passive-like derivation for the well-formed anaphoric clitic construction, where the clitic is a categorially underspecified external argument. Since this argument cannot be attracted to check Case or EPP, the object can skip over it to the subject position without Lethal Ambiguity arising. The remainder of the chapter is devoted to other potential cases of skipping.

Thesis Supervisor: Alec Marantz
Title: Professor of Linguistics

For I have not shown you that the moon shines more brilliantly by night than by day; you already knew it, as you also knew that a little cloud is brighter than the moon. Likewise you knew that the illumination of the earth is not seen at night, and in short you knew everything in question without being aware that you knew it.

—Galileo Galilei, *Dialogue concerning the two chief world systems*

Acknowledgements

I think it's fair to say that my linguistics career began about twenty-one years ago, when Miss Kathleen Hecmovich asked the Grade One class to tell her the difference between *a* and *an*. From the moment of realizing that such questions could even be asked, my fate was sealed. For the years of study culminating in this dissertation, I blame a long succession of excellent teachers, colleagues, friends, family members, and funding agencies, who failed in their duty to crush my enthusiasm for a profession that is content with nothing more ambitious than engaging the intellect and increasing the happiness of a few thousand people at minimal expense to the rest of the world.

Probably the greatest share of blame should go to Alec Marantz. Not only has Alec, as my thesis advisor, provided painstakingly detailed comments at every stage of the development of this dissertation—he has also been a source of inspiration and wisdom throughout my time at MIT. I'd estimate that in five years, I must have asked Alec about five thousand questions. He's provided valuable advice on every aspect of my professional life, and every conversation we've had about linguistics has pushed me (sometimes kicking and screaming) beyond the previous limits of my understanding. Alec has worked steadily against my unfortunate tendency to tinker with mechanics, always driving me towards new empirical discoveries. I can't imagine what my graduate career would have been like without his daily jokes, gossip, and provoking remarks.

Noam Chomsky also deserves a large share of the guilt for my linguistics education. As a member of my dissertation committee, Noam always saw and solved my problems before I realized they existed. Aside from his obvious contributions to the content of this dissertation, Noam's whimsical style of argumentation has made our appointments and e-mail correspondence both challenging and amusing—even if he did keep refusing to agree with my Albanian judgements.

When I asked David Pesetsky to join my dissertation committee, it was because I thought he would grill me mercilessly. Instead, to my relief, he turned out to be a uniformly encouraging and innovative generator of ideas. His suggestions made this dissertation much clearer than it would have been otherwise. I'm also grateful for his outstanding class lectures in my first year.

Though not a member of my committee, Morris Halle has been an important influence on this dissertation, as well as on my academic life in general. Morris's love of linguistics is equalled only by his dedication to creating a rich professional environment around him. I greatly appreciate his counsel in times of trouble. Only Morris could have inspired me to stay up all night thinking about the intractable morphology of conjunct forms in Algonquian, when I should have been working on an overdue syntax paper.

A couple of my recently graduated colleagues took the time to read all, or nearly all, of this dissertation, and I thank them for their extensive comments. Carson Schütze's regular correspondence from UCLA gave me many insights into the nature of morphological case. A fellow Torontonians and graduate of the University of Toronto, Carson was also able to indulge me in conversation about home and old friends. Jonathan Bobaljik (another Torontonians), raised a number of intriguing theoretical issues relating to the dissertation, and also made it his personal mission to ensure that I understood how nominative case and agreement work in Icelandic. As a graduate student, and then as a Harvard fellow, Jonathan contributed a great deal to the fun and challenge of linguistics at MIT.

Although I never managed to hand them anything written, two of my classmates were of enormous assistance in letting me talk through problems and ideas as the dissertation progressed. Norvin Richards could always be relied on to give sound advice on linguistic matters, aided by his simply vast knowledge of the literature, while the rigorous logic and theoretical aesthetics of Paul Hagstrom helped me navigate many a treacherous sea of data. Paul and Norvin were also my best friends at MIT; the three of us owe one another favours of such magnitude that we'll probably spend the next fifty years trying to settle the score. Thanks to Norvin for chocolate-chip cookies, Garrison Keillor stories, Moominvalley books, music by Arvo Pärt, reading aloud the *Kalevala*, commiserating with my angst on every possible topic, and trying to suppress his bizarre unconscious habit of surreptitiously touch-typing everything I said. Paul was wise enough not to take seriously my angst on every possible topic; thanks to him for quadrupling my computer skills, as well as for introducing me to many fine movies, TV addictions, video games, guinea pigs, and palindromes. It will be his fault if I call a napkin a 'pkin for the rest of my life.

Several other friends contributed to this dissertation in various ways. Heidi Harley's work was always extremely relevant and interesting, and we had several valuable e-mail exchanges. Heidi was also responsible for a great deal of the fun I had during my first two years at MIT. Her sense of humour and uniquely sane perspective make her an irresistible companion, even if she would insist on the misguided notion that I cut my bananas funny. Both before and during the writing of this dissertation, I had many conversations with Uli Sauerland, which invariably relieved my concerns on matters linguistic and otherwise. I was lucky to have Uli, Kazuko Yatsushiro, and little Kai as my extended family at 22 Magazine Street for a few weeks at the end of this summer. Danny Fox gave me a number of useful references over the course of the year, and always had insightful comments when I presented my work in progress. Conversations with Danny were a formidable and fascinating part of my experience at MIT, especially during the first couple of years.

Probably the most exciting confluence of research I experienced was the result of work by Elena Anagnostopoulou while she was a postdoc at MIT. Her research on clitic-doubling in Greek forms the basis of a large part of this dissertation, and her work with Artemis Alexiadou and Martin Everaert gave me even more to think about. Elena provided a steady stream of judgements and suggestions throughout the year, as well as a refreshing perspective on the European linguistics community. Another valuable resource was Léa Nash, a long-standing correspondent from the Université de Paris 8. Léa furnished me with endless Georgian judgements, as well as theoretical proposals full of originality and

pizzazz. I was fortunate to be able to attend her doctoral defense in Paris, a grand affair, and her post-defense party was so entertaining that it inspired me to throw one myself.

Many other people in the MIT linguistics community gave me useful ideas and bursts of motivation. It was always a pleasure to work with Shigeru Miyagawa, who was able to talk with equal interest about syntax, morphology, Japanese, and neurolinguistics. At East Campus, where I was a Graduate Resident Tutor, I found Shigeru as generous with his time in the role of Housemaster as he was in the role of linguist. I also had a good time modelling kimonos for an MIT audience with his fellow Housemaster, Cara Cheyette. Another comforting presence during my graduate career was Ken Hale. Ken's sharp insight, love of language, and gentle sense of humour make him an invaluable participant in any discussion of linguistics. Jim Harris helped me not only to understand Spanish clitics, but also to overcome a childhood fear of dogs by taking care of Montserrat, his gigantic German Shepherd-cum-wolf. I had enlightening appointments with Michel DeGraff, Irene Heim, and Sabine Iatridou, whose remarks continued to affect my ideas in new ways for months afterwards. I am also grateful to Michel for encouragement about my teaching abilities. Visiting student / Mind-Articulation postdoc Dave Embick was extremely informative about voice morphology and syntax, and assisted me both in clarifying my assumptions and in broadening the empirical coverage of my proposals. Thanks for brief, but important, conversations are also due to fellow students Marie-Claude Boivin, Idan Landau, Julie Legate, and Jon Nissenbaum.

I was able to discuss this work with several people outside the immediate MIT community as well. Meetings with Hagit Borer, Michael Brody, Guglielmo Cinque, John Frampton, Jacqueline Guéron, Jim Higginbotham, Richard Kayne, Jeff Lidz, Tanya Reinhart, Luigi Rizzi, and Alain Rouveret were especially instructive, as was my e-mail correspondence with Mark Baker, Chris Collins, Kunio Nishiyama, Laura Siegel, Yuji Takano, and Hiro Ura. Dianne Jonas has been a friend and confidante since we co-organized NELS in 1995; we had exciting discussions of our research on several occasions. I must also thank Alice Harris for very properly scaring the living daylights out of me at my first LSA talk, an experience I recommend for increasing the conscientiousness of every young linguist.

A number of people have been most kind in giving me native speaker judgements. These people include Sam Mchombo (Chicheŵa), Jonathan Bobaljik, Ben Bruening, Elissa Flagg, Paul Hagstrom, Ken Hale, Julie Legate, Alec Marantz, Lisa Matthewson, Jon Nissenbaum, Norvin Richards, and Jay Rifkin (North American English), Alec Byrne, Paul Elbourne (and friends), Colin Phillips, and Ralph Wedgwood (British English), Marlyse Baptista, Marie-Claude Boivin, Marie-Hélène Côté (and Jean-Pierre), Michel DeGraff, and Philippe Schlenker (French), Kai von Fintel, Martin Hackl, Irene Heim, Uli Sauerland, and Susi Wurmbrand (German), Idan Landau and Danny Fox (Hebrew), Rajesh Bhatt and Anoop Mahajan (Hindi), Höski Thráinsson, Olafur Jonsson, and Asta Sveinsdottir (Icelandic), Michela Ippolito and Sveva Besana (Italian), Takako Aikawa, Shigeru Miyagawa, and Kazuko Yatsushiro (Japanese), Pilar Barbosa (Portuguese), Masha Babyonyshev (Russian), and Karlos Arregui, Elena Benedicto, and Isabel Oltra-Massuet (Spanish). Thanks also to Victoria Massey for sharing her research on Albanian.

Others also deserve mention for contributing to the academic community that was my home for five years. Thanks to the classmates I have not already mentioned: to Rob Pensalfini, for laughs, tremendous acting performances, and unsingable song lyrics (possum-bandicoot-frillneckedlizard-emu-numbat-gecko-jumbuck-platypus-wallaby-snake-echidna-wombat-kangaroo, there!); to Judy Baek, for her wry insights, and for some great Korean and Japanese food; to David Braun, for the most memorable moving-day in my experience; and to Ingvar Löfstedt, for his delicate sense of the absurd.

My predecessors were especially good friends in the early years at MIT. Colin Phillips was more than a friend: he was an “older brother” and collaborator on a wide variety of projects, from MIT Working Papers in Linguistics, to the Human Language Project running team, to experiments using MEG. Regardless of the project, it was always challenging and inspiring to work with Colin, and I greatly appreciate the many hours he spent on my education. Andrew Carnie was a reliable source of information about everything from Canadian taxes to Slavonian hats, in addition being the most exhilarating dance partner I have ever had the honour to be swung around a room by. Orin Percus was a great friend and charades teammate, who introduced me to the many delights of Harvard Square. I also had an invariably good-natured housemate in Hubert Truckenbrodt, though I often worried about whether a person could really live on cigarettes and chocolate pudding.

The upcoming generations added a great deal to my MIT experience as well. Thanks to Ben Bruening for taking over the Managing Editorship of the MIT Working Papers in Linguistics from me, and to Jay Rifkin and Meltem Kelepir for taking it over from him. I’ve also enjoyed some intriguing linguistics discussions with Ben and Jay, and with Bridget Copley, webmeister extraordinaire. Hooi-Ling Soh’s calm cheerfulness always made her a reassuring presence, particularly when we were both writing our dissertations. If I had to stay late working, I was always glad to know that Susi Wurmbrand would be in the department until the first T started running—just in case I wanted to go and balance things on my head for her. The first-year students brought sanity to those of us finishing our dissertations; thanks to Elissa Flagg and Paul Elbourne for being particularly inclined to conversation at odd moments.

As a student in the RTG program, I benefited from getting to know a number of people in the Brain & Cognitive Sciences department. Thanks to Ken Wexler for constructive comments on my Generals papers and MEG research. Lab meetings on sentence processing were always lively, thanks to the quick wit and enthusiasm of Ted Gibson. It was a pleasure to organize the Neurolinguistics lab meetings with postdocs Jeannette Schaeffer and Edith Kaan, who were always ready with new ideas. Jaemin Rhee went out of her way to be friendly to me, and was the source of many excellent home-made pastries. I also enjoyed talking with Jenny Ganger, Rose Roberts, and Gina Rendon, whose obvious professionalism provided a model I could only strive to imitate.

There were many others who improved the quality of life at MIT. Wayne O’Neil and Maya Honda were a constant support; thanks to them for lots of gossip and chocolate, and for taking me out for noodles one night when I was particularly noodleless. Sylvain Bromberger was always a cheerful presence, and also the first person to succeed in making me understand late insertion of roots in Distributed Morphology. Cheryl Zoll always noticed when I got my hair cut, even though—as she would guiltily recall—professors apparently aren’t supposed to comment on such things. The administrative staff in the department went far beyond the call of duty in providing a welcoming environment. Bev Stohl helped me get last-minute letters of recommendation from Noam, and gave me motherly advice on matters too embarrassing to tell anyone else. Sheila Anderson’s kooky humour and poetic genius were always a delight, and I had conversations with Mary Ann Mroz about everything from pug dogs to the MIT alcohol policy. Jen Purdy was a great softball player and an outstandingly altruistic person, and Mary Grenham and Anne Cahill were generous with their time and resources, helping me with everything from arranging the MITWPL accounts to finding boxes when it was time to leave.

The students of 4th East at East Campus made my last two years memorable ones. From nightly cocoa to twinky games, from “slumber” parties to roller-blading, from the little barking dog to all-night discussions of libertarian philosophy—not to mention the endless mockery of my Canadianisms (eh?)—I was fortunate to be able to spend time with so many

remarkable people. In my concern for and delight in them, I was able to forget many of the worries that beset the dissertation year; and their insight constantly reminded me that greater age and experience does not necessarily mean greater wisdom. Particular thanks go to the hall chairs, Atif Chaudhry, Renée Ned, Alvar Saenz-Otero, Katie McCoy, Chris Thomas, and Susanna Mierau. I don't dare start naming other names, or these acknowledgements will be ten pages long.

So many others contributed to my graduate life that I despair of mentioning them all. Some of them are Calixto Aguero-Bautista, Artemis Alexiadou, Bob Berwick, Brigit Cosgrove, João Costa, Paul Crook, Marilyn Goodrich, Dan Grodner, Rumi Izvorski, Celia Jakubowicz, Yoonjung Kang, Cornelia Krause, Jay Keyser, Masa Koizumi, Howard Lasnik, Beth Levin, Vivian Lin, Geoff Loftus, Adee Matan, Gaurav Mathur, David McKay, Seth Minkoff, Edson Miyamoto, Renate Musan, Lynn Nichols, Rolf Noyer, Satoshi Oku, Rachel Pearl, Molly Potter, Liina Pytkkanen, Andrea Rackowski, Janina Rado, Taylor Roberts, Vaijyanthi Sarma, Dominique Sportiche, Monica Santa Maria Somohano, Christina Sorrentino, Luciana Storto, Linda Thomas, Wei-tien Dylan Tsai, George Tsoulas, Bill Turkel, Fleur Veraart, Sonny Vu, Brad Waller, Tessa Warren, Jaimie Young, and Andrea Zukowski. The rest of you know who you are; thanks for being there. The research reported here has also been supported by a NSF Research Training Grant (DIR 9113607) awarded to MIT and by a SSHRC doctoral fellowship (752-93-2393).

I would also like to thank my professors at the University of Toronto for introducing me to linguistics as an undergraduate and a Master's student, and for their continued support during my doctoral research. Elizabeth Cowper's ironclad reasoning first attracted me to the linguistics department and later persuaded me to stay; working under her supervision was always rewarding. Elan Dresher awakened my interests in morphology and the philosophy of linguistics. He and Alana Johns have been my main connection to the Toronto linguistics department since I left, and the source of many hilarious rants (Elan) and dry asides (Alana). Tea-breaks and linguistics discussions with Betsy Ritter were great fun while she was a postdoc at the University of Toronto; she's the only friend I have who shares my taste for manly shoes. I'm also grateful to Ed Burstynsky, Diane Massam, Keren Rice, Ron Wardhaugh, and my fellow graduate students at U of T.

I'm indebted to several of my friends from Toronto for their moral support over the last few years. Carol Percy offered endless witticisms and thoughtful advice about the academic life. Though I met her as an avid student of the first course she ever taught (History of the English Language), Carol secured my permanent regard by offhandedly finishing a difficult crossword puzzle faster than I thought possible. My fellow writer and old friend Jason Taniguchi could be depended on to disagree violently with me about movies, but still to arrange for artsy entertainment whenever I went home. Sara Posen and I began and finished the various stages of our academic careers at the same time (only, somehow, she also had time to get engaged). Her similar experiences in a different field have always been a consolation. I enjoyed lots of gossip and decaf coffee with Harvard math whiz Ravi Vakil, and traded literary criticism with Hugh Thomas over e-mail. My wicked friend Shannon Robinson remains in Toronto; I've often wished for her savage wit. I was lucky to share an apartment in Boston with my oldest buddy, Sarah Gordon, who taught me how to argue when I was eight years old. She's improved with age, though I don't think I have.

My siblings have always encouraged me from afar; many thanks to Diane, Jon, Ross, and especially to Greg. I dedicate this thesis to my parents, John and Carol McGinnis, who I thank for their love, tolerance, and phone calls. Their own achievements are a continual inspiration to me. In the end, it's probably a good thing that they used to laugh at me when I'd get mad and stomp up the stairs to my room. I'd just sit up there calculating how soon I could come down.

Abbreviations

ABS	-	absolutive case
ACC	-	accusative case
AOR	-	aorist tense/aspect
ARB	-	arbitrary referent
CAUS	-	causative
CL	-	clitic
CLS	-	classifier
CP	-	completive aspect
DAT	-	dative case
ERG	-	ergative case
EVID	-	evidential tense/aspect
F	-	feminine gender
FOC	-	focus
FUT	-	future tense/aspect
FV	-	final vowel
GEN	-	genitive case
HON	-	honorific
ICP	-	incompletive aspect
IMP	-	imperfect aspect
NACT	-	nonactive voice
NEG	-	negation
NOM	-	nominative case
OP	-	object pronoun
PAS	-	passive voice
PERF	-	perfect aspect
PL	-	plural
PRES	-	present tense
PST	-	past tense
PV	-	aspectual preverb
Q	-	question marker
RECIP	-	reciprocal
REFL	-	reflexive
SG	-	singular
SP	-	subject pronoun
SUBJ	-	subjunctive mood
TS	-	thematic suffix
UNACC	-	unaccusative voice

Contents

Abstract	3
Acknowledgements	5
Abbreviations	10
Table of Contents	11
Chapter 1 Locality and Case	13
1. Feature-based Locality	14
2. Locality and Case	23
2.1 Move α	25
2.2 Attract F	30
3. Cross-Linguistic Variation	40
3.1 Case Suppression	41
3.2 Varieties of Case	46
4. Equidistance and Superraising Revisited	56
5. Outline of the thesis	61
Chapter 2 Advancing	63
1. Transitives	65
2. Double Object Constructions	68
2.1 Short Passives	69
2.2 Passive Alternations	77
3. Dative Subjects	80
4. Absolute Locality	88
5. Summary	99
Chapter 3 Leapfrogging	101
1. A-scrambling	102
1.1 Movement into Multiple Specifiers	107
1.2 A-Scrambling Obeys Locality	112
1.2.1 <i>Advancing of Idiom Chunks</i>	115
1.2.2 <i>Leapfrogging of Idiom Chunks</i>	118
1.2.3 <i>Leapfrogging and Floated Quantifiers</i>	120
1.2.4 <i>Against Skipping</i>	122
1.3 Summary	124

2.	Lethal Ambiguity	126
2.1	Japanese	128
2.2	Georgian	131
2.3	Hindi	134
2.4	Scrambling into spec-RP	136
3.	Leapfrogging to the Subject Position	138
3.1	Long Passives	141
	3.1.1 <i>Obligatory long passives</i>	142
	3.1.2 <i>Symmetric passives</i>	145
3.2	Structural / Inherent Alternations	148
3.3	Clitic Doubling	154
4.	Overt Movement of a Lower Argument	162
Chapter 4	Skipping	171
1.	Anaphoric Clitics	172
1.1	Transitives with an anaphoric clitic	174
1.2	Indirect objects	177
1.3	Anaphoric clitics and ECM verbs	184
1.4	Arbitrary agents	185
1.5	C-command and binding	192
2.	Raising in English	198
2.1	The experiencer c-commands the embedded clause	201
2.2	The embedded subject raises past the experiencer	209
3.	Ditransitive unaccusatives in Georgian	215
4.	Summary	217
	References	219

Chapter 1

Locality and Case

In a raising construction in English, an argument moves to the subject position of a higher clause from a more deeply embedded subject position, indicated in (1b) by *t*, the trace of movement.

- (1) a. Mehitabel was sleeping.
b. [Mehitabel] seemed [*t* to be sleeping].

No question arises in (1b) as to which element should become the subject. A subject must be of a particular syntactic/semantic category; let us suppose for the moment that this category is that of Determiner, a functional category associated with nominal elements. In (1b) there is only one Determiner phrase (DP): *Mehitabel*. In other cases, however, more than one DP is present in the clause. For example, the embedded clause in (2) has both subject and object DPs. Here there is an issue as to which element will become the subject of the matrix clause. As we can see, the embedded subject (2b), but not the object (2c), can raise to the matrix subject position.

- (2) a. Archy liked Mehitabel.
b. [Archy] seemed [*t* to like Mehitabel].
c. * [Mehitabel] seemed [Archy to like *t*].

In this dissertation, I explore the factors that determine which argument moves to an available position. I intend to demonstrate that argument movement (A-movement), like other types of syntactic movement, is subject to a locality principle defined roughly as follows: what moves to a given position is the closest element of the appropriate type. In (2b), the embedded subject is the closest DP to the subject position, so it moves there instead of the object. Of course, terms like “closest” and “appropriate type” will need to be defined below.

The A-movement picture is also influenced by other factors. If locality alone determined which argument should undergo movement, then the only possible source of cross-linguistic variation in A-movement would be differences in the relative structural positions of the arguments. As we will see, however, there is typological variation in which argument undergoes A-movement, even among arguments in the same relative positions. This variation results from interactions of locality with other factors, such as abstract Case and the Extended Projection Principle. For example, even if the embedded subject and object in (2c) were equivalent for the purposes of locality, the object could not raise to the matrix subject position, because it checks Case within the embedded clause. There is no way for the embedded subject to check Case within this (nonfinite) clause, so it is free to raise and check Case in the higher subject position.

1 Feature-based Locality

This dissertation aims to resolve a tension between certain existing accounts of locality in A-movement. One such account is set forth by Rizzi (1990). Rizzi proposes a locality condition on syntactic dependencies much like the one mentioned above. This condition, *Relativized Minimality*, prevents a syntactic dependency of one kind from being established across an intervening element of the same kind, since the intervening element is then a closer antecedent for the lower position in the dependency. Thus the dependency in (3) is blocked if Y is a potential antecedent for Z.

(3) ... X ... [... Y ... Z ...]

Rizzi investigates three kinds of syntactic dependencies, based on the type of positions involved: A-chains; A-bar chains, e.g. the chain linking a *wh*-phrase with its trace; and X^0 chains, e.g. the chain connecting a verb with its trace. He argues that dependencies like those in (4) are ill-formed because they are blocked by an intervening potential antecedent.

- (4) a. * [John] seems [that *it* is likely [*t* to win]].
 b. * [How] do you wonder [[*which problem*] [PRO to solve *t*]]?
 c. * [Have] they *could* [*t* left]?

Under this view, the A-chain headed by *John* in (4a) is blocked by the expletive *it*, which occupies an A-position as the subject of an embedded clause. Similarly, the A-bar chain headed by *how* in (4b) is blocked by the A-bar specifier *which problem*, and the X⁰-chain headed by *have* in (4c) is blocked by the intervening X⁰ *could*.

Relativized Minimality is an extension of the Government and Binding (GB) theory (Chomsky 1981), but its insights have been adopted in the subsequent literature, under various formulations. These insights assume a central role in the feature-based Attract theory of movement (Chomsky 1995), where minimality is treated as an intrinsic property of the movement operation. Nevertheless, Relativized Minimality appears to be incompatible with another well-known proposal concerning A-dependencies. Rizzi (1986) argues that a well-formed A-chain cannot be established across an intervening argument with the same “referential index.” This configuration is schematized in (5), where Y blocks the dependency between the coindexed X and its trace *t*. I will refer to the locality condition proposed by Rizzi (1986) as Indexical Locality.

- (5) ... X_{*i*} ... [... Y_{*i*} ... t_{*i*} ...]

Although similar in spirit to Relativized Minimality, Indexical Locality constrains dependencies between elements with the same referential index, and not between elements of the same position type. In fact, Indexical Locality presupposes that an A-chain across an intervening argument is well-formed, provided that the arguments in question have distinct referential indices. For example, Rizzi (1986) contrasts ill-formed dependencies like (6a) with well-formed ones like (6b). By Relativized Minimality, however, the A-chain between *Gianni* and its trace in (6b) should be blocked by the intervening argument *gli*, assuming that *gli* (or its trace) occupies an A-position. Note that the well-formedness of (6b) cannot

be explained by saying that the intervening clitic *gli* never occupies an A-position. As we will see, cases like (6b) also arise when the intervening argument is a full phrasal DP.

- (6) a. * [Gianni_i] non si_i sembra t_i [t_i fare il suo dovere].
 G. not REFL seem to do the his duty
 'Gianni doesn't seem to himself to do his duty.'
- b. [Gianni_i] non gli_i sembra t_i [t_i fare il suo dovere].
 G. not to-him seem to do the his duty
 'Gianni doesn't seem to him to do his duty.'

Rizzi's (1986) explanation of the contrast in (6) has been applied to similar contrasts in Albanian nonactives (Massey 1990, 1992), and in German and Japanese A-scrambling (Snyder 1992, Miyagawa 1997, Yatsushiro 1997).

A second problematic case for Relativized Minimality is the possibility of raising into a higher clause past an experiencer, as in (7). The experiencer appears to be in an A-position c-commanding into the embedded clause, since the quantified DP experiencer *each poet* in (7a) can bind the pronoun *his* in the embedded clause, yielding the following interpretation: For each poet P, Mehitabel seemed to P to be P's most devoted admirer. According to traditional assumptions, well-formed binding is possible only from a c-commanding A-position, so the experiencer in (7) seems to fit this description. The experiencer is also c-commanded by the raised subject, as shown by the ability of *each poet* to bind *his* in (7b). Thus the experiencer occupies an A-position that intervenes between another argument and its trace, contrary to the predictions of Relativized Minimality. Moreover, the construction is well-formed even if the raised subject binds an anaphoric experiencer, as in (7c).¹ Cases like this violate Indexical Locality as well as Relativized Minimality.

¹ Postal (1971) and Baker, Johnson & Roberts (1989) report that the reciprocal *each other* is grammatical in this experiencer position, while a reflexive anaphor (such as the one in (7c)) is ungrammatical. However, for many speakers, myself included, cases like (7c) are quite acceptable (see, e.g., Pesetsky 1995:104).

- (7) a. [Mehitabel] seemed to each poet [*t* to be his most devoted admirer].
 b. [Each poet] seemed to his admirers [*t* to be quite inspired].
 c. [Archy] seems to himself [*t* to be rather a good poet].

This dissertation attempts to resolve the apparently conflicting locality conditions on A-movement. I will adopt the Attract F theory of movement (Chomsky 1995), in which syntactic movement is feature-attraction into the “checking domain” of a head. Under this theory, locality depends on the intrinsic features of heads and arguments, rather than on their position types or referential indices. We have seen three cases of A-movement with distinct properties. In the first case, exemplified by raising from a transitive clause in English, only the highest argument can raise. In the second, a lower argument can raise past the highest one, but no anaphoric dependency can be established between them. Examples of this kind include raising past a clitic experiencer in Italian. In the third case, a lower argument can both raise past the highest argument and bind it; this situation arises in raising past an experiencer in English. Under the feature-based theory of locality, all three cases involve strictly local A-movement.

The first case, *advancing*, involves local movement of an argument originating in the highest position. The second case, *leapfrogging*, arises when a lower argument first raises into the same locality domain as the highest one, then moves on. Leapfrogging prevents an anaphoric dependency from being established between the two arguments. Finally, *skipping* occurs when the highest argument lacks the necessary features for movement at a given step of the derivation. In this case, a lower argument can raise past it without first moving into the same locality domain, and an anaphoric dependency can be established between the two arguments.

(8)

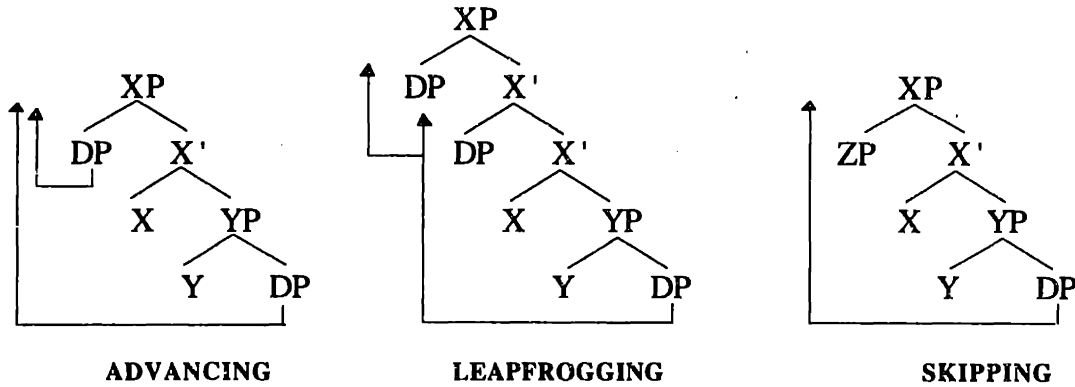

Though the terms *advancing*, *leapfrogging* and *skipping* will be useful, they are simply descriptive terms, applying to classes of derivations that vary within a class, as well as across classes. The differences among derivations arise not from different types of movement, but from differences in the intrinsic features of the constituents involved.

I will argue that locality is defined over checking domains, rather than by strict c-command. If two elements are in the same checking domain, they are equidistant from an attracting head. The checking domain of a head X includes its specifiers and any head immediately adjoined to X. Under this definition, the checking domain of X in (9) is {WP, ZP, H}. This is a simplified version of the definition in Chomsky (1993:11), which also includes phrases adjoined to XP and to specifiers of XP (not shown). I leave aside the question of whether or not the complement (YP below) should also be treated as a specifier. I will continue to use the traditional terms *complement* and *specifier* to avoid confusion, but the distinction plays no role in this dissertation. The specifier/adjunct distinction also plays no role here.

(9)

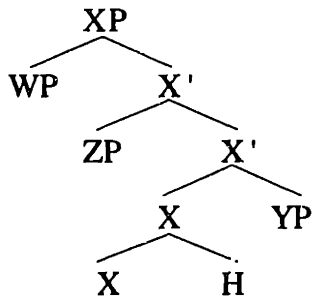

WP and ZP (and, presumably, H) are equidistant for the purposes of locality. However, if X c-commands another head Y, an element in the checking domain of X is closer to an attracting head than an element in the checking domain of Y.

Attraction is also constrained as to the relative position of the elements that can be attracted. Specifically, a head can only attract from positions below its checking domain. This constraint can largely be derived from cyclicity. The syntactic structure is constructed roughly from the bottom up. The only elements available for attraction are those already in the existing structure, so a head cannot attract an element from the checking domain of a higher head (Epstein 1994). Furthermore, I assume that in selecting an element for attraction, a head disregards elements already in its checking domain.² Thus these elements can neither be attracted by the head themselves, nor block attraction of a lower element. On the other hand, an element *can* check features via Merge. For example, an expletive can check EPP (and sometimes Case) features of T when it merges. A theta-relation between a head and an argument can also be seen as an instance of checking features under merger.

A central proposal to be presented here is that an anaphoric dependency cannot be established between two specifiers in the same checking domain, even if one or both of them raises out of this domain. On the view that there is some respect in which an anaphor is nondistinct from its antecedent, we can stipulate that this kind of nondistinctness is ill-formed for two specifiers in the same checking domain.³ I will call the proposed stipulation *Lethal Ambiguity*, since the nondistinct specifiers cancel the derivation by rendering it uninterpretable. In the Italian raising example (10a), discussed above, the raised subject cannot bind the matrix experiencer. Under the account presented here, the subject raises

² Alec Marantz (p.c.) points out that this restriction would also follow from cyclicity if all features of a head were checked simultaneously. We would then need some additional principle to determine the ordering of specifiers for a single head. Ordering of specifiers is discussed in detail in section 3, where it is assumed that the features of a head are checked sequentially.

³ The nondistinctness between an anaphor and its antecedent has often been expressed by coindexation. Chomsky (1995) proposes to eliminate referential indices from syntactic theory, in keeping with the Minimalist goal of reducing theoretical mechanisms. It may be that anaphoric dependencies should be expressed by local feature-checking between the anaphor and the antecedent, but I put this issue aside here.

through an intermediate position in the same checking domain as the experiencer, so Lethal Ambiguity arises if an anaphoric dependency is established between the two arguments. In English, on the other hand, the embedded subject does not raise through the same checking domain as the experiencer, so a binding relation is permitted.

- (10) a. * [Gianni] non *si* sembra [t] [t] [t] fare il suo dovere]].
 G. not REFL seem to do the his duty
 ‘Gianni doesn’t seem to himself to do his duty.’
- b. [Archy] seems [to *himself* [t to be rather a good poet]].

Lethal Ambiguity links the contrast between (10a) and (10b) to the features of the intervening argument. The clitic experiencer in (10a) is a DP with a Case feature, so there is no way for the embedded subject to move past it without first moving into the same checking domain. Otherwise, as a closer DP, the experiencer would block the embedded subject from raising into the matrix subject position. On the other hand, the experiencer in (10b) is a PP, so the embedded subject can raise past it without moving into the same checking domain. This theory predicts that there should be independent evidence for the category difference between the experiencers in (10a) and (10b).

Lethal Ambiguity captures many of the same facts as Indexical Locality. According to Indexical Locality, however, no A-chain can be established across an intervening coindexed argument. Under the Lethal Ambiguity account, an anaphor can intervene between an antecedent and its trace, provided that the antecedent never occupies the same checking domain as the anaphor. This modification makes it possible to account for the contrast in (10).

Lethal Ambiguity also makes it possible to answer a long-standing question from the literature. It has been argued that a transitive clause with an anaphoric clitic has a derivation similar to a passive, with the logical object raising to the syntactic subject position (Marantz 1984, Kayne 1986, Snyder 1992, Pesetsky 1995). One source of evidence for the passive derivation is the choice of auxiliary used with the past participle in

a number of Romance languages, which is ‘have’ for actives without an anaphoric clitic (11a), but ‘be’ for passives (11b) and for actives with an anaphoric clitic (11c-d). The examples in (11) are from French.

- (11) a. Le petit Nicolas l'a vu *t* dans le miroir.
 the little N. him-has seen in the mirror
 ‘Little Nicholas saw him in the mirror.’
- b. [Le petit Nicolas] était vu *t* dans le miroir.
 the little N. was seen in the mirror
 ‘Little Nicholas was seen in the mirror.’
- c. * Le petit Nicolas s'a vu *t* dans le miroir.
 the little N. REFL-has seen in the mirror
 ‘Little Nicholas saw himself in the mirror.’
- d. [Le petit Nicolas] s'est vu *t* dans le miroir.
 the little N. REFL-is seen in the mirror
 ‘Little Nicholas saw himself in the mirror.’

The passive-like analysis of the anaphoric clitic construction raises the question of why the anaphoric clitic *cannot* be generated as the object, as in (11c) (Marantz 1984). Anaphoric direct objects are generally well-formed—why not an anaphoric object clitic?

Under current assumptions about Case checking, the derivation with an anaphoric object clitic is ruled out by Lethal Ambiguity. Chomsky (1995) proposes that the direct object of a transitive clause satisfies its Case requirements by “checking” a Case feature on the head that assigns a theta-role to the external argument. Thus an object that checks Case by overt movement raises to a specifier in the same checking domain as the external argument. If the object clitic has to check Case overtly, then Lethal Ambiguity will prevent an anaphoric dependency from arising between the object and the external argument. Thus an object clitic can in principle be an anaphor, but if so, it yields an uninterpretable derivation. On the other hand, if the object checks Case without overt movement, the external argument of a transitive clause can bind it, as in English (12b).

- (12) a. * [Le petit Nicolas] se [t t [voit t]].
 the little N. REFL sees
 'Little Nicholas sees himself.'

- b. [Archy] [t [sees himself]].

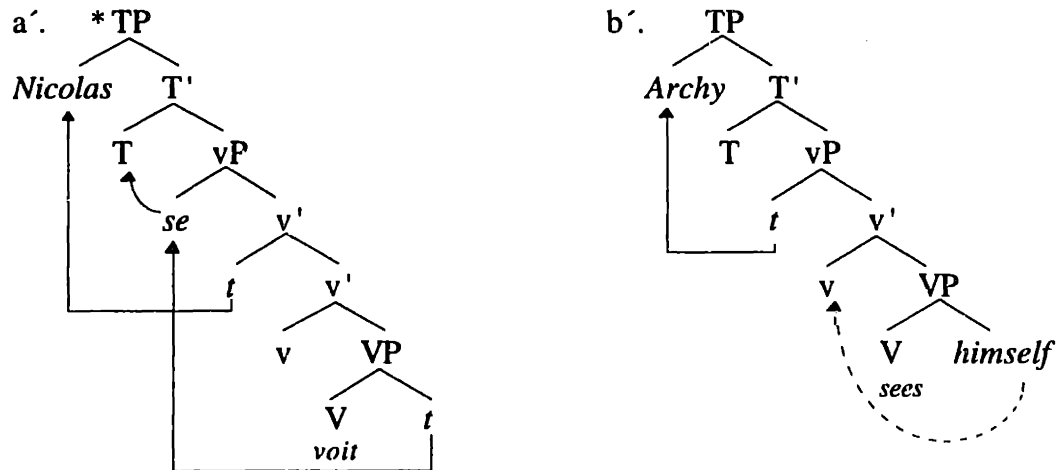

Of course, a question still remains as to how the grammatical anaphoric clitic construction is derived. In the grammatical derivation, the logical object raises to the subject position, binding an anaphor in the external argument position. Under Indexical Locality, however, such a derivation should be impossible. The external argument intervenes between the derived subject and its trace, so the derived subject should not be able to bind it. Under Lethal Ambiguity, the derivation should be well-formed, provided that the logical object is able to move past the external argument on its way to the subject position without moving through the same checking domain.

- (13) [Le petit Nicolas] se [t [voit t]].
 the little N. REFL sees
 'Little Nicholas sees himself.'

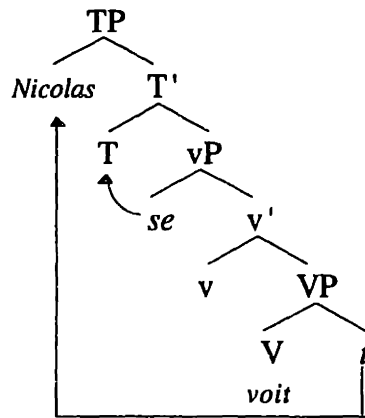

In general, of course, it is impossible for a lower argument to skip over the external argument. I will propose that such movement is possible in (13) because the external argument is featurally underspecified, lacking a D category feature, as well as abstract Case.⁴

In this dissertation, then, I adopt a feature-based theory of locality, rather than a position-based theory like Relativized Minimality. The interactions between movement and anaphora captured under Indexical Locality will be treated not as the result of a general locality condition on chains, but as the result of a separate restriction, Lethal Ambiguity, which applies only to anaphoric dependencies. I assume that all languages obey feature-based locality. The main source of variation across languages is in the Case properties of the arguments undergoing movement. In the next section, I introduce locality and Case, and discuss certain roles they play in the Minimalist framework of Chomsky (1995, 1998), which I will adopt here.

2 Locality and Case

The question as to what motivates and constrains A-movement has been approached in two different—but not mutually exclusive—ways. One is to say that movement is driven by the

⁴ It is also possible that the object moves through the same checking domain as the external argument, if Lethal Ambiguity arises only between DPs. The same account cannot be straightforwardly given for the PP experiencer in (10b), since this is a “cascade” PP (Pesetsky 1995, Phillips 1996). Cases like (10b) will be discussed further in Chapter 4.

argument: a DP has a Case requirement, which can be satisfied only by movement. Under this view, A-movement is straightforwardly constrained both by the limited distribution of positions where an argument can satisfy its Case requirement, and by the fact that once an argument has done so, it need not move further. Another approach maintains that predicates or heads are what drive movement. Certain verbal or functional heads or phrases have requirements that can be satisfied only by a local relation with a DP. Here it is typically locality that constrains movement; the head or predicate enters a relation with the closest DP. Recent work in the Minimalist framework combines the two approaches, arguing that A-movement is constrained by both Case and locality.

A central innovation of the Minimalist Program is the proposal that the logical subject and object might be “equidistant” from the syntactic subject position. In the terms of Chomsky (1995), the object can check abstract Case in a specifier of the head that assigns a theta-role to the subject (*v*). Chomsky does not resolve the issue of how the object is blocked from raising to the syntactic subject position. He proposes that if the object moves to a specifier below the merged (theta-related) specifier, Shortest Move alone might ensure that the higher, merged specifier raises; otherwise, the two specifiers must be treated as equidistant, with Case determining which one moves. In this chapter, I provide a new argument in favour of the latter view. This argument hinges on evidence that in some instances, the merged specifier raises to the subject position, while in others, the moved specifier raises. Regardless of whether the merged or moved specifier is higher, Shortest Move cannot determine which one moves onwards. I adopt the principle that Case-checking blocks certain types of movement: if the moved specifier checks Case, it cannot move further to the subject position (Chomsky 1998). However, locality also plays a crucial role in blocking “superraising” constructions, in which a higher argument that has checked Case blocks a lower argument from raising past it, even if this lower argument has not checked Case.

This section provides some theoretical background on abstract Case and locality in A-movement. In section 3, I outline my main proposals concerning cross-linguistic variation in A-movement. In section 4, I review the crucial roles played by Case and locality in capturing the facts from section 3.

2.1 Move α

Under GB theory, Move α operates freely, with its output evaluated against principles such as the Case Filter (Chomsky 1981, Vergnaud 1985). In its original form, the Case Filter requires each noun phrase (here, each DP) to have Case assigned to it by a verb or functional head. Of course, many DPs lack overt case morphology; morphological case cannot be equated with the abstract Case required to satisfy the Case Filter. Consider again the sentences in (14).

- (14) a. A cat saw Archy yesterday.
 b. [Archy] was seen t yesterday.

Although the object in (14a) has Case assigned to it, no object Case is assigned in a simple passive such as (14b). In GB, nothing forces the movement that allows a DP to satisfy the Case Filter—the object in (14b) is free to remain in its base position or to move. However, if the object remains in its base position, the Case Filter will mark the sentence as ungrammatical. If it moves to the subject position, it receives nominative Case, so the sentence will pass successfully through the Case Filter. Note that there is no comparison between derivations: the derivation without movement is ungrammatical, not because there is a preferable derivation, but simply because it violates the Case Filter.

Under this account, the Case requirement of the object in (14b) can be satisfied only by movement to the subject position. As Marantz (1991) points out, however, such movement is independently required by the Extended Projection Principle (EPP), which requires each sentence to have a syntactic subject (Williams 1980, Chomsky 1982, Rothstein 1983). Thus, Marantz argues that the object moves to the subject position, not to

satisfy its own requirements, but to satisfy those of the main clausal predicate. The EPP also plays a role in transitive clauses. Under a widely adopted proposal, the logical subject of a transitive clause is generated within the verb phrase, then raises to a higher position associated with the syntactic subject (Kitagawa 1987, Kuroda 1988, Sportiche 1988)—here, the specifier of IP (Inflection Phrase).

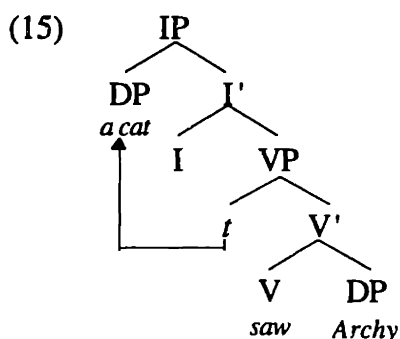

In GB theory, the object of a transitive clause is said to be “governed” and assigned Case in its base position by the main verb. It might be supposed that the logical subject raises to the syntactic subject position in order to satisfy its Case requirement. Given the EPP, however, movement to the syntactic subject position is independently necessary. Locality would be sufficient to determine which argument moves: the logical subject is generated above the position in which the object is generated and licensed, so a “shortest move” requirement would ensure that the logical subject, and not the object, moves to the subject position.

The model of syntax in Chomsky (1993) differs considerably from GB theory. First of all, Chomsky proposes a different overall architecture for the grammar. GB theory adopts the “Y-model” of grammar, schematized in (16). A “deep” D-structure is built from lexical items, which is mapped to a “surface” S-structure by applications of Move α . S-structure is mapped to Logical Form (LF) by further applications of Move α , which affect semantic interpretation but not pronunciation, and to Phonetic Form (PF) by other operations, which affect pronunciation but not interpretation.

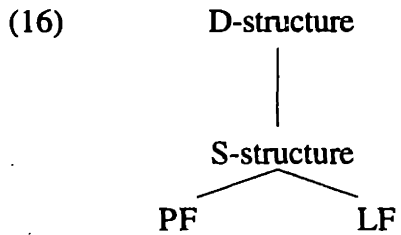

Chomsky (1993) replaces this model with the “T-model” (17). Under this proposal, there is no D-structure; instead, the derivation proceeds by building the syntactic structure in stages from the bottom up. At each stage, either an item is merged from the lexicon, or an existing part of the structure is moved. At some point, known as “Spell-Out,” the derivation splits into LF and PF components. Unlike S-structure, however, Spell-Out is not a special level of representation; it simply occurs at the point in the derivation that allows LF and PF conditions to be best satisfied. Movement before Spell-Out or in the PF component is “overt”; for Chomsky (1993), a second cycle of “covert” movement takes place in the LF component, again proceeding from the bottom up. A derivation “converges” if it meets the minimum requirements of both interfaces, and “crashes” otherwise.

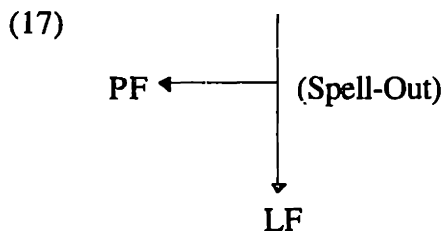

A second development of this early work in the Minimalist Program (MP) is in the nature of syntactic constraints. In GB, constraints are absolute; a derivation is grammatical if it satisfies all constraints, and ungrammatical (or at least marginal) if it violates any. In Chomsky (1993), the syntax is subject to economy conditions, which can be violated if necessary to ensure convergence. Based on a restricted comparison set, these conditions select the derivation that best satisfies their requirements. This kind of comparison among derivations introduces a degree of computational complexity that later developments of MP strive to eliminate.

A reflex of the Case Filter survives under MP, but the details differ considerably. Chomsky (1993) introduces the notion that each DP entering the derivation has a Case feature, which must be “checked” against an appropriate head in order to yield a well-formed derivation. The need to satisfy Case requirements is subsumed under a general requirement, Full Interpretation, which requires all “uninterpretable” features to be checked. This requirement drives all syntactic movement, not just movement for Case. As a special property of DPs, the Case Filter reduces to the requirement that every DP is generated with a Case feature.

Chomsky (1993) also proposes to eliminate the notion of “government.” He argues that grammatical relations between an XP and a head is canonically established in the specifier-head configuration. Consequently, he proposes that both the subject and object raise (overtly or covertly) to check Case in the specifier of a higher functional projection. Case checking involves the deletion of both an uninterpretable Case feature on the DP, and a corresponding uninterpretable Case feature on the Case-checking head. Case is checked by Tense (T) and the verb (V), but each of these heads can adjoin to a higher functional head Agr (associated with agreement), to check Case against the specifier of AgrP. For example, the subject of a transitive clause in English raises overtly to the subject AgrP (AgrSP), while the object raises covertly to the object AgrP (AgrOP) (18). T adjoins overtly to AgrS to check nominative Case on the subject, and V adjoins covertly to AgrO to check accusative Case on the object. The overt movement of the subject in (18) precedes covert movement of the object, which occurs in the second (LF) cycle.

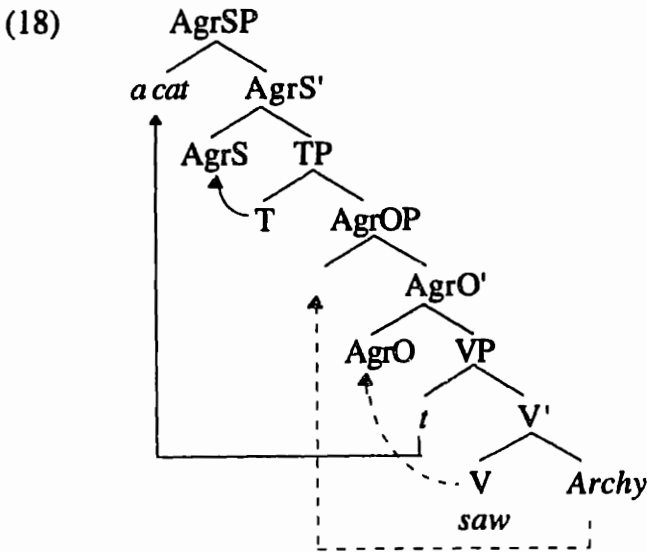

Covert adjunction of V to AgrO renders spec-VP and spec-AgrOP “equidistant” from the base position of the object, allowing it to move past the base position of the subject into spec-AgrOP. If the verb adjoins to AgrO overtly, the object can leapfrog overtly over the subject in spec-VP (19). AgrO must then adjoin to a higher position (T or AgrS) in order for the subject to leapfrog over the object.

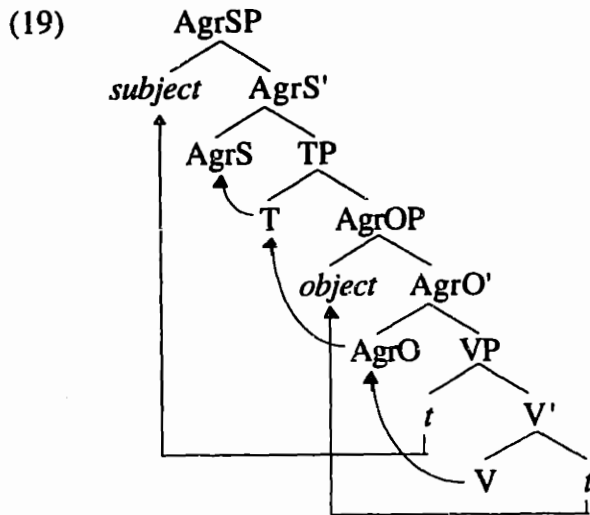

Given equidistance, then, the “closest” argument is not necessarily the one that raises to the subject position. Equidistance makes it possible for a lower argument to raise past a higher one without violating locality (Shortest Move).

The account just presented assumes a “leapfrogging” derivation, in which the object checks Case above the base position of the subject. On the other hand, a number of authors

present evidence for the “split-VP” or “stacking” hypothesis, whereby the logical subject of a transitive clause is generated in the specifier of a verb phrase above the base VP, with AgrOP sandwiched between the two VPs (Bobaljik 1995, Carnie 1995, Koizumi 1995). Under this story, an object shifts to a position below the base position of the subject (20). The logical subject is always the highest argument, so locality is sufficient to ensure that it raises to the subject position.

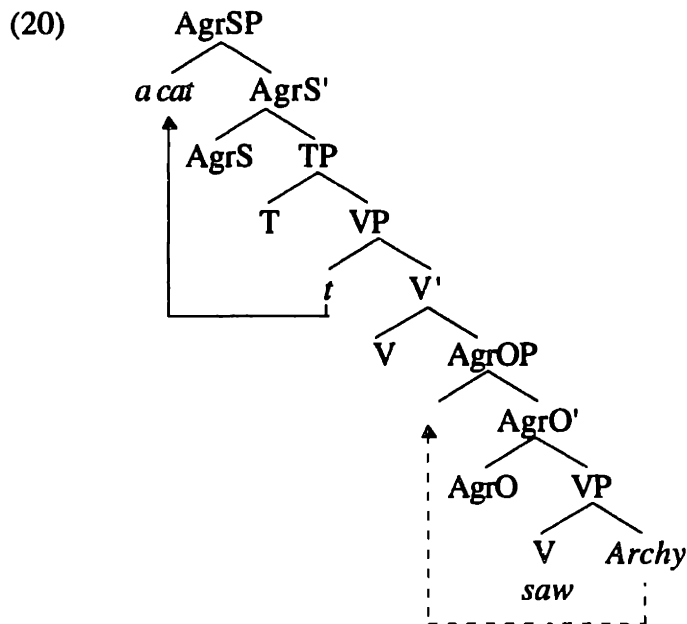

2.2 Attract F

One objection raised to the Economy theory of Chomsky (1993) is that it assumes extensive computational resources. Recall that violations of an Economy condition need not rule out a derivation, unless the condition is better satisfied by a competing convergent derivation. For example, the Economy principle Greed requires an element to check a feature at each step of movement. However, this principle can be violated if necessary to ensure convergence. In (21), the embedded object raises through spec-TP to allow the EPP feature of the embedded T to be checked, although no features of the argument are checked by this step of movement; this DP does not check Case until the finite matrix clause.

(21) $[_{TP} [Archy] \text{ seems } [_{TP} t \text{ to have been } [_{VP} \text{ seen } t]]]$.

The need for comparisons among derivations adds to the computational complexity of the model. Chomsky (1995) moves away from the Economy framework with the introduction of Attract F. Under Attract F, movement is driven by an absolute condition of “Suicidal Greed” (Chomsky 1998): at each step of movement, a feature of a head attracts a feature that checks and deletes it. In (21), for example, movement to the embedded subject position is directly driven by the EPP feature of the embedded T.

According to Chomsky (1995, 1998), a checking relation can be established in three ways: Merge, Attract, or Move. The simplest operation is Merge, which inserts a new element from the Numeration, an array of lexical items to be used in the derivation. For example, the EPP feature of T can be satisfied by merging an expletive in the specifier of TP. Likewise, the theta-property (theta-“feature”) of a head is satisfied by merging an argument with it. Attract involves movement of a feature directly to the attracting head (Chomsky 1995:297):

(22) K attracts F if F is the closest feature that can enter into a checking relation with a sublabel of K.

In this definition, we can treat K as the attracting head, and a sublabel of K as a feature of that head.⁵ In Chomsky (1995), feature-attraction is treated as a second cycle of movement, following all operations of Move. However, I will adopt the revision of Chomsky (1998), in which there is only a single cycle of movement, with Move and Attract interleaved.

Feature-attraction is “covert,” having no effect on pronunciation. Overt movement (Move) is a combination of three operations. The head K attracts a feature F; a feature in the bundle of formal features to which F belongs identifies a category α to be “pied-piped” along with F; and α is merged to K or a projection of K. Thus Move displaces the attracted

⁵ In context, actually, K is the root node—the highest projection at a given point in the derivation—and a sublabel of K is (roughly speaking) a feature of the head of K. The description given here fits better with the revisions of Chomsky (1998).

category so as to affect pronunciation.⁶ In checking the features of a given head, the simpler operation Merge is preferred to the more complex operation Move. One consequence is that a feature that can be satisfied by either Merge or Move is satisfied by Move. Another consequence is that if a head has one feature checked by Merge, and another checked by Move, the one checked by Merge is checked first.

Though Attract is driven by properties of the attracting head, Move (as an additional process) can be forced by properties of either the attractor or the attractee. For instance, EPP can be checked only by Merging a DP. If an expletive is available in the Numeration, it can check the EPP feature of T via bare Merge. Checking features of T by merging a semantically contentful DP leads to an uninterpretable derivation, since each DP requires a theta-role, and T has no theta-feature. Thus, if no expletive is available, a DP already merged in the structure must move to check the EPP feature of T. In this case, Move is driven by the EPP feature of the attractor. However, Chomsky (1998) proposes that a feature of the attractee is responsible for identifying the phrase α to be pied-piped along with the attracted feature. We can exploit this proposal to capture an alternation between clitic objects, which check Case by Move, and nonclitic objects, which can check Case by Attract. Let us suppose that when the Case feature is being attracted, the feature [clitic] identifies the phrase α as the full clitic XP, which then merges in a specifier of the attracting head. If the [clitic] feature is missing, the phrase α either is not identified, or is identified as null, so only the Case feature is attracted.

Along with the Attract F theory of movement, Chomsky (1995) adopts the notion that a single head can have multiple specifiers (cf. Ura 1994). Meanwhile, he proposes that semantically contentless heads such as Agr should be eliminated from the syntax. Chomsky assumes a split VP, where the logical object of a transitive clause is the complement of the base verb V, while the logical subject is an “external” argument, receiving its theta-role in

⁶ This division is probably too simplistic. Pesetsky (fall 1997 class lectures) and Fox (1998) argue that Move can be covert.

the specifier of a higher verb (ν). Instead of checking Case on AgrO, the object checks Case on ν , either by feature-attraction or by overt movement to a second specifier of ν . Subject Case and EPP are checked directly on T. Case-checking deletes uninterpretable Case features on both the DP and the head, but EPP-checking deletes only the EPP feature on the head. The attracted D feature is interpretable, so it is not deleted by checking. Thus a DP can check EPP successive-cyclically on more than one head.

In the derivation of a simple transitive clause, the base verb V begins by merging with the direct object DP, *Archy* in (23). V then projects to create a VP, which merges with ν . The logical subject (here *a cat*) merges with ν P, and ν attracts the Case feature of the object. ν P then merges with T. T attracts the Case and D features of the logical subject, then the full DP moves to satisfy the Merge requirement of EPP.⁷

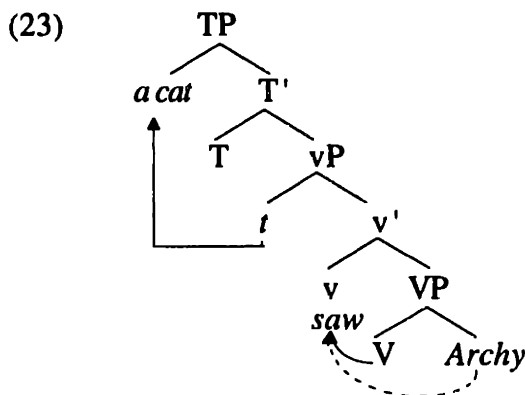

Note that in this theory, covert feature-attraction of the direct object to ν precedes the overt movement of the subject to spec-TP.

As noted above, where the object moves overtly to a Case position, I assume that overt movement is driven by a feature of the DP. Overt shift of definite objects is possible in Icelandic, as shown in (24).

⁷ There is some evidence that the main verb raises overtly to adjoin to ν in English, based on its ordering with respect to multiple complements (Collins 1997:15). For example, we find the order *Mehitabel seemed [to Archy] [to be quite peevis]*, not **Mehitabel [to Archy] seemed [to be quite peevis]*. Since the position of DPs is my main concern in this thesis, however, I will generally omit traces of verb movement.

- (24) a. Jón las ekki bækurnar.
 J. read not the books
 'John did not read the books.'
- b. Jón las [bækurnar] ekki t .
 J. read the books not
 'John did not read the books.' (Collins & Thráinsson 1996)

It has been argued that object shift involves movement of the object into the specifier of its Case-checking head.⁸ When v is added to the derivation, the logical subject first merges to check the theta-feature of v . Then v attracts the Case feature of the [+definite] object, which can opt to identify the full DP as the phrase to be pied-piped along with the Case feature. If it does so, the object shifts to spec- vP . At this stage of the derivation, both the logical subject and the direct object occupy specifiers of vP . However, only the logical subject can become the syntactic subject. Zaenen, Maling & Thráinsson (1985) give a number of tests for subjecthood in Icelandic. For example, if another constituent precedes the verb, the syntactic subject immediately follows the verb. In a transitive clause, only the logical subject can immediately follow the verb under these circumstances, as shown in (25).

- (25) a. [_{CP} Með þessari byssu skaut [_{TP} Ólafur [_{vP} refinn ekki t [_{vP} t]]]].
 with this shotgun shot Olafur the fox not
 'Olafur didn't shoot the fox with this shotgun.'
- b. * [_{CP} Með þessari byssu skaut [_{TP} refinn [_{vP} t ekki Ólafur [_{vP} t]]]].
 with this shotgun shot the fox not Olafur
 'Olafur didn't shoot the fox with this shotgun.' (O. Jonsson, p.c.)

The claim that the moved object and the base position of the logical subject are both in specifiers of vP raises the theoretical possibility that the two arguments are equidistant for locality purposes. If so, locality cannot be responsible for ruling out the "inverse" derivation for a transitive clause, in which the logical object moves to the syntactic subject position,

⁸ However, I argue in Chapter 3 that not all object shift involves movement to a specifier of vP .

while the logical subject occupies the syntactic object position.⁹ Since this derivation is ill-formed, the grammar must have some way to rule it out.

Chomsky (1995) suggests two possible ways of blocking the inverse derivation. If a shifted object checks Case in the lower specifier of *vP*, below the position where the logical subject is merged, locality might be sufficient to ensure that the logical subject raises to the specifier of TP (26a). On the other hand, if the object shifts to a position above the logical subject, movement of the logical subject to spec-TP cannot be forced by locality alone, since the object is closer to T (26b). In this case, the two specifiers of *vP* would have to be equidistant from T in order for the lower specifier to be attracted at all.

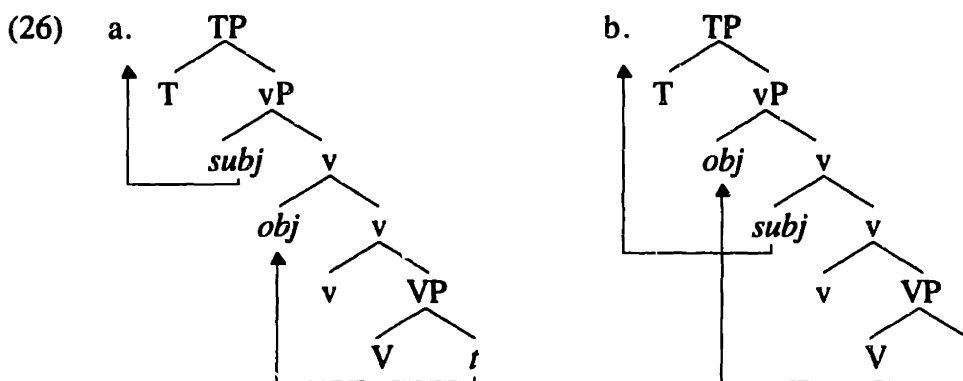

Note that in an Attract theory, equidistance is a property of potential attractees for a given head; this formulation differs from that in Chomsky (1993), where equidistance is a property of potential landing sites for a given argument. To ensure that only one of two equidistant arguments can raise to spec-TP, reference must be made to the features of the two arguments. For example, the object, but not the subject, has checked its Case feature by the time T is added to the derivation.

Jonas (1996) provides evidence for the latter, equidistance-based approach. She argues that the object can shift to a position above the base position of the logical subject.¹⁰

⁹ Marantz (1995) shows in detail how the theory of Chomsky (1993) blocks the inverse derivation.

¹⁰ For Jonas, the adverb *aldrei* in (27) marks the left edge of the VP, with the shifted object occupying the specifier of a higher AgrOP. If the shifted object occupies a specifier of *vP*, the adverb can be treated as occupying another specifier. Since it has no Case or D-feature to satisfy the Case or EPP features of T, the adverb does not interfere with attraction of the logical subject.

In the transitive expletive construction in (27), an expletive is merged in the specifier of TP. The logical subject is in its base position, and the direct object has shifted to a position above it from within vP . Nevertheless, the indefinite “associate” is the logical subject, *neinir stúdentar*. Assuming that the associate checks Case on T, (27) is an instance of (26b), with the subject and object equidistant from T.

- (27) [_{CP} Það lásu [_{TP} t [_{vP} [þessar bækur] aldrei neinir stúdentar [_{vP} t í fyrra]]]].
 there read these books never any students last year
 ‘No students ever read these books last year.’

Further arguments for the equidistance-based approach will be given at the end of the chapter, based on evidence presented in the following section. I will assume, then, that specifiers of a given head are equidistant for the purposes of attraction by a higher head.¹¹ However, attraction obeys the stipulation in (28).

- (28) Once an argument has checked Case, it cannot undergo further movement to check EPP.

This principle can in part be derived from the definition of Move, by saying that the Case feature of a DP is responsible for identifying the phrase to be pied-piped in attraction to check EPP (Chomsky 1998).¹² Once the Case feature has been checked and deleted, it cannot identify a phrase for pied-piping, so Move is blocked. I will call this mechanism Case Identification. The object of a transitive clause cannot raise to spec-TP, because it has already checked its Case on v by the time T is added to the structure. Thus the inverse derivation is blocked by Case Identification. Even if it is generated with the wrong morphological case, the object must check its abstract Case feature on v . A morphological case mismatch between the DP and the head cancels the derivation (Chomsky 1995: 370).

¹¹ At least, a higher specifier that cannot be attracted does not block attraction of a lower specifier. Richards (1997b) argues that locality does in fact *prefer* attraction of a higher specifier, if possible.

¹² Chomsky (1998) does not explicitly limit the application of this principle to EPP-checking, as I do here. However, an argument can undergo other kinds of overt movement after it has checked Case, including A-scrambling (see Chapter 3).

Since Case Identification requires no comparison between derivations, it is computationally simpler than a proposal made by Chomsky (1995) for ruling out the inverse derivation. This earlier proposal involves an economy principle that minimizes the number of operations in a derivation. Suppose that the direct object checks its Case in spec-*v*P. If it then raises to spec-TP, it can check the EPP feature of T, but not the Case feature, since its own Case feature has already been checked and deleted. In the theory of Chomsky (1993), where all (overt or covert) movement is phrasal, the unchecked Case feature of T would be sufficient to rule out this derivation. However, Attract F allows T to attract a Case feature from one element, while another checks EPP. For example, in the expletive construction (27) above, the expletive checks the EPP feature of T, but the Case feature of T is checked by the indefinite associate, which then triggers verb agreement. The same is true in English (29).

(29) There were three typewriters on the table.

If not for Case Identification, then, an object that has checked Case on *v* could raise and check the EPP feature of T, with the logical subject checking Case on T by bare Attract. In the theory of Chomsky (1995), however, the inverse derivation requires an extra operation. According to this theory, the EPP feature of T attracts the highest DP, whose Case feature is attracted along as a “free rider.” Thus, instead of a single operation checking both Case and EPP, the inverse derivation would need one operation to check EPP (movement of the object) and another to check Case (attraction of the logical subject’s Case feature). Chomsky (1995) proposes that the shorter derivation blocks the longer one, in accordance with an economy principle we can call “Minimize Operations.”

Although (29) also requires two operations to satisfy the Case and EPP features of T, there is no “shorter” alternative to this derivation. If the expletive were absent, the associate could check the Case and EPP of T. However, Chomsky proposes that only derivations with the same lexical items are compared for economy purposes, so no comparison can be made between derivations with and without expletive *there*. If the

expletive is present in the derivation, it checks EPP, but not Case; thus the associate must check Case via Attract.

Notice that Minimize Operations would have to be understood as a global economy condition.¹³ Local economy is computationally simpler, since it merely compares alternatives for the next step to be taken at a given point in the derivation (Collins 1997); a global economy condition requires more computation, since it must take earlier or later steps into consideration as well. Consider the ungrammatical derivation in (30), with the inverse derivation taking place in a nonfinite embedded clause. Even in a language where the object can raise overtly to spec-*v*P, as in Icelandic, such a derivation is ill-formed; yet no single step of movement violates Minimize Operations. The embedded T has only EPP to check, not Case, so once the object shifts, both specifiers of *v* are equally eligible to check this feature. If the object raises to the specifier of the embedded T, it then must raise to the specifier of the matrix T. At this point, attraction of the lower logical subject is not a possibility, since the two arguments are no longer equidistant. Nevertheless, the matrix T can attract the Case features of the embedded logical subject, so all uninterpretable features are checked off.

(30) *_{[TP} The book T⁰ [_{vP} seems [_{vP} [_{TP} *t* to have [_{vP} *t* three men read [_{vP} *t*]]]]]]

Evaluated globally, this derivation is less economical than one in which the logical subject raises to the embedded spec-TP, then checks the Case and EPP features of the matrix spec-TP simultaneously; however, each step in (30) individually obeys Minimize Operations. Under Case Identification, on the other hand, the object cannot check EPP on the embedded T, since it first checks Case on the embedded *v*. In the interests of avoiding global constraints on derivations, therefore, we will keep to the Case Identification account. By this account, once the object has checked Case in the embedded clause, it cannot check the EPP feature of T even if T lacks Case features.

¹³ Thanks to Noam Chomsky for raising this point.

According to the account adopted here, then, the inverse derivation of a transitive clause is blocked by Case Identification, rather than by locality. However, Chomsky (1995) also argues that locality plays a key role in constraining A-movement. Consider a situation in which the highest DP argument is alone in a checking domain. If this argument has an unchecked Case feature, it can raise to check Case or EPP. For example, it is assumed that the subject of a raising construction checks EPP, but not Case, in the specifier of the embedded infinitival T (31a). It then raises again to check the Case and EPP features of the finite T. However, if the highest argument has checked its Case feature, it cannot be attracted further. In (31b), the subject checks its Case within the embedded finite clause, so it cannot raise again to check the Case or EPP feature of the matrix T. These features remain unchecked, and the derivation crashes.

- (31) a. $[_{TP} \text{ [Three typewriters]} \text{ appear } [_{TP} \text{ } t \text{ to be } [_{PP} \text{ } t \text{ on the table}]]]$.
 b. * $[_{TP} \text{ [Archy]} \text{ seems } [_{TP} \text{ (that) } t \text{ wrote a novel}]]]$.

In (31), locality again plays no role. In (31a) the DP that raises is the only one that has not checked Case, since the only other DP, *the table*, checks Case within its PP. In (31b), no DP can raise, since both *Archy* and *the table* check Case within the embedded clause.

On the other hand, suppose that a lower DP has an unchecked Case feature. Even if the highest DP cannot itself raise, it can block this lower DP from raising. For example, expletive *it* in (32a) checks Case in the embedded finite clause, so it is blocked from raising to the subject position of the higher finite clause (cf. 31b). However, the subject of the lower embedded infinitival, *Archy*, has an unchecked Case feature. Nevertheless, it cannot undergo “superraising,” moving past the expletive to the matrix subject position. Such a derivation is impossible under feature-based locality. The expletive is a DP, so it blocks attraction of any lower DP. Meanwhile, Case Identification prevents the expletive from moving itself. The only well-formed derivation with the desired interpretation has *Archy* raised into the subject position of the embedded finite clause, and the expletive merged in the matrix clause (32c).

- (32) a. * [It] seems [_{CP} (that) [_{TP} *t* is likely [_{TP} Archy to have written a novel]]].
 b. * [Archy] seems [_{CP} (that) [_{TP} it is likely [_{TP} *t* to have written a novel]]].
 c. It seems [_{CP} (that) [_{TP} [Archy] is likely [_{TP} *t* to have written a novel]]].

Of course, locality is not the only possible explanation for the ill-formedness of (32b). An alternative explanation would be that the expletive can be inserted only when no well-formed movement is possible (Marantz 1991). In (32a-b), movement of *Archy* is possible, so insertion of the expletive would be ruled out. However, Chomsky (1995:346) argues that Merge is preferred to Move generally. Thus the expletive must be inserted in the subject position of the embedded clause in (33a), instead of moving the DP *three typewriters*, as in (33b).

- (33) a. [There] appear [_{TP} *t* to be [_{PP} three typewriters on the table]].
 b. * There appear [_{TP} [three typewriters] to be [_{PP} *t* on the table]].

If this line of argument is correct, then the ill-formedness of superraising in (32b) is most straightforwardly viewed as the result of a locality violation. In the next section, I will present further evidence for locality in A-movement.

3 Cross-linguistic variation

The previous section went in detail through the derivation of a simple active transitive clause. The traditional view of a passive (without a *by*-phrase) is that the external argument is absent and the object Case feature (here, the Case feature of *v*) is suppressed. Instead, the object checks subject Case (here, the Case feature of T).¹⁴ However, the full picture is by no means so simple. In a number of constructions, there is not only *v* and V but also an additional head, R. I will use this label to designate a class of heads that assign “indirect” theta-roles, including goal, benefactive, and experiencer. In this section, I propose that

¹⁴ In a well-known paper, Baker, Johnson & Roberts (1989) have argued that the external argument of a passive is syntactically present, and that it has the accusative Case usually associated with the object. This account is not compatible with the theory of locality and Case presented in this dissertation.

Case in a “nonactive” (passive or unaccusative) can be suppressed either on ν or on R, with consequences for movement possibilities. I also sketch out a view of morphological and abstract Case licensing that plays an important role in determining which argument moves at a given step in the derivation. I assume that both abstract Case and morphological case (m-case) features are checked in the syntax, though not necessarily at the same time (Schütze 1997). The facts presented here provide evidence that both Case and locality constrain A-movement.

3.1 Case suppression

Let us consider the derivation of a ditransitive clause. Asymmetries between direct and indirect objects (Barss & Lasnik 1986) have led to the conclusion that the indirect object asymmetrically c-commands the direct one. I will assume that a ditransitive verb is decomposed into an articulated structure like that of (34), with the direct object (DO) receiving a theta-role from the base verb V, and the indirect object (IO) receiving a theta-role from a higher “applicative” verb, here called R (Marantz 1989, 1993, Ura 1996).

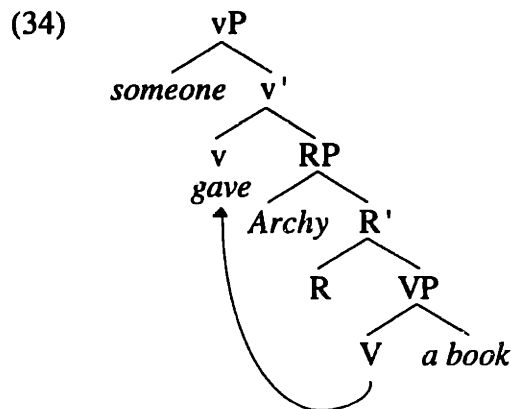

When both objects have structural Case, the DO checks Case on R, and the IO checks Case on ν , while the external argument checks its Case on T.

In passives and unaccusatives, a Case feature is suppressed. For concreteness, I will assume that the choice of ν is responsible for the active or passive “voice” of a clause, as well as for the transitive/unaccusative distinction (Harley 1995, Kratzer 1996, Marantz

1997). Transitive clauses are associated with a causative v that assigns a theta-role to an agent, while unaccusative v means something more like ‘be’ or ‘become,’ and assigns no theta-role. I make no attempt here to decide the issue of whether or not a theta-role is assigned to an external argument in the passive (see Embick 1997 for discussion).

Syntactic evidence suggests that this argument is absent; if it is present, however, it lacks Case, cannot antecede a pronoun or anaphor, and does not block movement of the object to subject position. Elsewhere, I will argue that such an external argument does exist in reflexive clitic constructions; there v assigns its theta-role to a highly underspecified non-DP argument, which lacks Case and cannot be attracted to spec-TP. Thus it is theoretically possible that the causative v of a passive clause has its theta-feature checked by an underspecified non-DP argument. On the other hand, it is also possible that the external argument of a passive is simply not syntactically projected.¹⁵ A number of languages have an “arbitrary agent” construction, in which the verb is active in form, but the syntax is passive, with a lower argument raising to subject position. I will refer to the range of constructions with such “passive” syntax (including unaccusatives) as *nonactives*.

In some languages, nonactive v always lacks a Case feature. For example, we have seen that the object of a passive transitive clause in English checks Case on T, not on v . In American English, the Case feature of v is also suppressed in a passive ditransitive. As a result, the IO checks Case on T instead. In such a language, only the higher object of a passive ditransitive raises to the subject position. Other languages of the same type include Chichewa, Tzotzil, and Danish. (35) shows a simplified structure, omitting PartP.

¹⁵ The theta-role of the external argument can be assigned to an argument *by*-phrase (cf. Marantz 1984, Goodall 1998, among many others), but there is little evidence that the *by*-phrase is itself “external.”

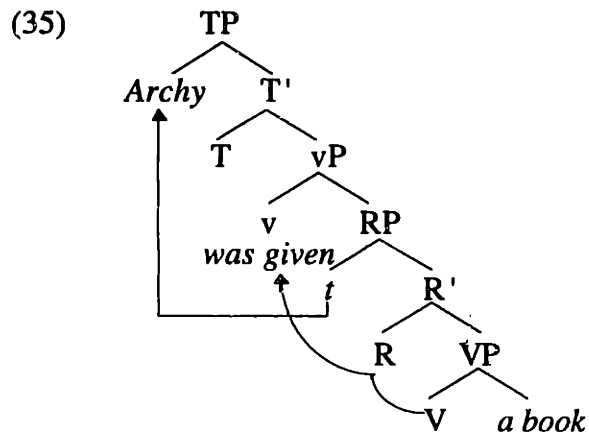

The Case feature of R is still intact, so the DO checks Case there as usual. We predict that the “inverse” derivation of a passive will be blocked in these languages, just like the inverse derivation of an active transitive. That is, the DO should not be able to cross over the IO, because it checks Case on R. Once the DO has checked Case, Case Identification prevents it from raising to check the EPP feature of T, so the IO raises instead. In English, moreover, the object does not move to spec-RP.¹⁶ Thus the inverse derivation of a passive is also blocked by locality: the IO is the only DP close enough to raise to spec-TP.

As we noted before, Lethal Ambiguity prevents an anaphoric dependency between two arguments in specifiers of the same head. However, as in the simple transitive, the direct object can check Case by feature-attraction, so the DO and IO need not occupy specifiers of the same head. In English, for example, R attracts only the features of the DO, so no Lethal Ambiguity arises.

- (36) a. $[_{TP} [A \text{ cat}] [_{VP} t \text{ showed } [_{RP} \text{ Archy } [_{VP} \text{ himself}]]] (\text{in the photograph})]$.
 b. $[_{TP} [\text{Archy}] [_{VP} \text{ was shown } [_{RP} t [_{VP} \text{ himself}]]] (\text{in the photograph})]$.

Evidence that the DO still checks structural Case in the passive can be found in Chaga (Bresnan & Moshi 1990). Chaga is a Bantu language that shows object agreement with one or both objects of a ditransitive verb, via “pronoun incorporation” into the verb (37a). This agreement is taken to indicate that both objects have structural Case. In the passive below,

¹⁶ If it did, we would expect the order *I gave a book Archy*, where *a book* has raised to a specifier of RP above *Archy*.

the IO raises to the subject position, triggering subject agreement. Note, however, that the DO can still trigger object agreement (37b).

- (37) a. N-a-i-**ki-m**-lyi-i-a.
 FOC-SP-prs-OP-OP-eat-APPL-FV
 ‘He is eating it for him/her.’
- b. M-ka n-a-i-**ki**-lyi-i-o.
 wife FOC-SP-prs-OP-eat-APPL-pass
 ‘The wife is being affected by someone’s eating it.’

Chaga has what are known as “symmetric” passives, in which either object of a ditransitive clause can raise to the subject position.¹⁷ When the DO raises to the subject position, the IO can still trigger object agreement on the verb (38). I will call this the “long passive,” by contrast with the “short passive” in (37b).

- (38) K-i-**m**-lyi-i-o.
 SP-prs-OP-eat-APPL-pass
 ‘It (i.e., the food) is being eaten for/on him/her.’

We have argued above that if an argument checks Case, there is no way for it to raise further to the subject position. If this view is correct, then the fact that the DO raises to the subject position in (38) shows that it does not check Case on R in this derivation. I propose that in Chaga, passive ν can retain its own Case feature, but co-occur with an RP complement headed by an R whose Case feature is suppressed.¹⁸ As a result, ν has a Case feature for the IO to check, while the DO raises and checks Case on T. In accordance with feature-based locality, T cannot attract the DO unless it is the “closest” DP. If the DO remains in its base position prior to attraction by T, the closest DP would then be the IO, which has already checked its Case. For the DO to be accessible to T, it must raise into a specifier of RP, so that it is as close to T as the IO. Thus I assume that when the Case feature of R is suppressed, it instead has an EPP feature, which attracts the DO into its

¹⁷ The symmetric/asymmetric difference also has consequences for *wh*-movement (Marantz 1993), which I leave aside here.

¹⁸ Ura (1996) makes a similar suggestion.

specifier. From this position, the DO can move to check its Case in the subject position

(39).¹⁹

(39)

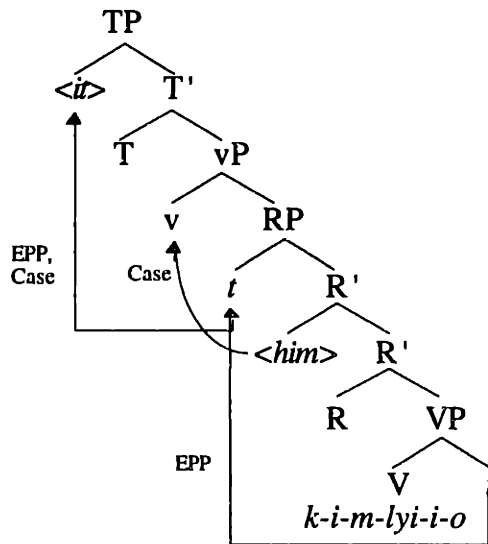

Notice that for the derivation of (38) to converge, the IO must not raise to spec-vP. If it does, the IO and DO are no longer equidistant from T, and the closer IO then blocks the DO from being attracted to spec-TP. Thus we can conclude that the IO in (38) checks Case on *v* by bare Attract.

Note, too, that the EPP feature of R cannot be checked by the IO, which checks the theta-feature of R by Merge. Of course, EPP *can* be checked by bare Merge, alone or simultaneously with another feature (i.e., Case). Unlike a theta-feature, however, the Case feature of a head does not require Merge. We can suppose that each feature of a head that requires Merge must be checked by a different instance of Merge.²⁰ Thus EPP, which

¹⁹ Notice that at the point at which *v* is added to the derivation, the IO and the DO are both in specifiers of R. Either argument could then be attracted to check the Case of *v*, while the other argument raises to spec-TP. This may genuinely constitute a free option, or the passive *v* with Case in Chaga may be required to attract the IO to satisfy its morphological case requirements, as in Albanian (see below).

²⁰ Alec Marantz (p.c.) makes the intriguing suggestion that the same element cannot check the EPP feature and the theta-feature of R because what I am calling the theta-feature is actually an EPP feature. This proposal has extensive ramifications for the theory presented in this thesis. One simple consequence has to do with the c-command relation between specifiers of RP. In Chapter 3 I adopt the proposal of Richards (1997b) that a head attracts the highest element of a particular kind, while later movements to specifiers of the same head “tuck in” underneath the first specifier. However, I argue that tucking-in occurs only when both specifiers check the same type of feature. If the theta-feature and EPP are the same feature, the second (moved) argument—here, the DO—should tuck in under the first (merged) argument, here the IO. The proposal has more serious consequences for my claim that reflexive clitic constructions have a categorially

(...cont.)

requires Merge, cannot be checked by the same argument that merges to check a theta-feature. Since Merge precedes Move, the theta-feature of R is checked first by merging the IO, then the EPP feature by moving the DO. If the DO checks the theta-feature of R, and the merged element checks the EPP feature of R, the derivation will be uninterpretable, since then one argument will have two theta-roles, and the other only one.²¹

3.2 Varieties of Case

In the last section, we saw that certain cross-linguistic differences in A-movement arise from the option of suppressing Case on *v* or R in a nonactive. Up until this point, we have assumed only one type of Case, namely structural Case, which is checked on a functional head. In this section, I will argue that Case can also be checked when a DP merges with its theta-assigner. This type of Case-checking corresponds to the traditional notion of inherent Case (cf. Chomsky 1986). The availability of structural or inherent Case on heads gives rise to additional cross-linguistic differences in A-movement.

Cross-linguistic variation also arises from morphological case requirements. I assume that m-case is dissociated from abstract Case (Harley 1995, Schütze 1997). This dissociation can be seen perhaps most clearly in the phenomenon of “quirky case.” A quirky argument checks Case by attraction to a functional head, but its m-case is determined inherently by its theta-assigner. We can say that the head assigning a theta-role to the quirky argument has an inherent m-case feature, which must be checked by a matching m-case feature on the argument that checks its theta-feature.²² I will argue that a head can also *specify* the m-case feature of the DP that checks its theta-feature, even if this

(...cont.)

underspecified (non-DP) external argument. Since such an argument cannot check the EPP feature of T, it should also be unable to check an EPP (theta-) feature on a head. That is, the non-DP external argument should only appear where it can receive a theta-role without checking a theta-feature, perhaps only in the *v*-VP configuration. I leave this line of inquiry for further research.

²¹ However, it is possible that the EPP feature of R can be checked by merging an expletive in spec-RP, which then raises to spec-TP. To my knowledge, this possibility has not yet been tested.

²² See Schütze (1997) for an account of the distribution of m-case.

m-case feature is checked structurally on another head. In particular, R can specify dative m-case on an argument that checks both Case and m-case on *v*.

In this section we will focus on variations in the Case-checking properties of R. Different variants of R have structural or inherent Case features and/or m-case specifications. The EPP and Case features of T can also be checked by Merge (of an expletive), though not “inherently,” since T assigns no theta-role. It is unclear whether or not *v* can check Case or m-case inherently. In general, the agent of a transitive clause has structural Case, even in a language with quirky subjects (Zaenen, Maling & Thráinsson 1985). Nash (1993, 1995) proposes that ergative agents bear a “lexical” (quirky/inherent) Case, but she argues that the ergative DP is merged internal to the base VP, not in spec-*v*VP.

The different types of *v* and R to be assumed for ditransitive constructions are summarized in (40) and (41).

(40)

Types of <i>v</i>	Examples (Ditransitive)
Case (ACC); theta	Active: English, Chaga
Case (DAT); theta	Active: Albanian, Greek (DAT clitic)
Case; theta	Active: Icelandic
theta	Active: Greek (no DAT clitic)
Case (ACC)	Long passive: Chaga
Case (DAT)	Long passive: Albanian, Greek (DAT clitic)
—	Short passive: English, Chaga, Icelandic Passive: *Greek (no DAT clitic)

(41)

Types of R	Examples (Ditransitive)
Case (ACC)	Active/Short passive: English, Chaga
EPP	Long passive: Chaga (?)
Case (ACC); inherent DAT m-case	Active: Icelandic
Case (NOM); inherent DAT m-case	Short passive: Icelandic
Case (ACC); inherent DAT m-case specification	Active: Albanian, Greek (DAT clitic)
EPP; inherent DAT m-case specification	Long passive: Albanian, Greek (DAT clitic)
Case (ACC); inherent Case (DAT)	Active: Greek (no DAT clitic)
inherent Case (DAT)	Passive: *Greek (no DAT clitic)

These charts are of course far from complete. For example, there may also be instances of *v* that assign a theta-role, but have no Case feature to check. This type of *v* may be present

in unergative clauses, where there is an overt agent but no overt object. On the other hand, it has been argued that an unergative verb has a null cognate object (Hale & Keyser 1993). In some languages there is evidence that this null object checks structural Case (Bobaljik 1993, Dobrovie-Sorin 1998). At least in these languages, unergative ν presumably has a structural Case feature for a null object to check. There are also other combinations of features for R that are not considered here. A logical next step would be to develop a constrained theory of the features of ν and R, and of the combinatorial constraints on different variants of these heads. No such theory is attempted in this dissertation.

In the last section, we saw instances where the Case of R is satisfied by Attract, not by Merge. For example, in an English ditransitive, the Case feature of R is satisfied in both actives and passives by attracting the Case feature of the DO. Thus the theta-specifier of R (the IO) checks Case, not on R, but on a higher functional head, ν or T. The same is true in Icelandic, except that the IO checks m-case by Merge with R, so its m-case is the same whether it checks abstract Case or ν , as in the active (43a), or on T, as in the passive (43b). Zaenen, Maling, & Thráinsson (1985) argue in detail that a dative subject, such as the one in (43b), occupies the same structural position as a nominative subject, like that in (43c).

(42) ν and R in Icelandic ditransitives

	ν	R
Active	Case; theta	Case (ACC); inherent DAT m-case
Passive	—	Case (NOM); inherent DAT m-case

- (43) a. $[_{CP} [_{Ég}] \text{ gaf } [_{TP} t \text{ } [_{VP} t \text{ } [_{RP} \text{konungi} \text{ } [_{VP} \text{ambáttina sína}]]]]]]]$.
 I.NOM gave a king.DAT maidservant.ACC self's
 'I gave a king, his, maidservant.'
- b. $[_{CP} \text{Um veturinn voru } [_{TP} [\text{konunginum}] \text{ gefnar } [_{VP} [_{RP} t \text{ } [_{VP} \text{ambáttir}]]]]]]]$.
 in the winter were the king.DAT given.NOM.PL slaves.NOM
 'In the winter, the king was given maidservants.'

- c. [CP Með þessari byssu skaut [TP Ólafur [VP t [VP refinn]]]].
 with this shotgun shot Olafur.NOM the fox.ACC
 ‘Olafur shot the fox with this shotgun.’ (ZMT 1985)

I assume that the DO in (43a-b) checks its Case on R. Note that in (43b) its m-case is nominative, triggering agreement on the verb.²³ This case/agreement pattern might be taken to indicate that the DO is in a checking relation with T. A nominative DP is generally possible only in the context of a finite T. On the other hand, the nominative object in Icelandic is clearly not a syntactic subject. These observations motivate Schütze (1997) to propose that a nominative argument checks, not Case, but nominative m-case on finite T. However, nominative m-case is not exactly the same for objects as it is for subjects. For example, a nominative object in Icelandic must be third-person (44a), while a nominative subject can be first- or second-person (44b). Moreover, nominative case is not universally associated with verb agreement. The nominative subject of an embedded infinitival clause can be first- or second-person (44c), but only triggers agreement on the matrix verb if it is third-person (44d). Even a third-person nominative object in Icelandic reportedly does not trigger agreement when a quirky argument intervenes between this object and finite T (44e).

- (44) a. Konunginum var gefinn hún. / ...*var/varst gefinn þú.
 king.DAT was.3SG given her.NOM / was.3SG/2SG given you.NOM
 ‘The king was given her/*you.’
- b. Þú varst gefinn konunginum.
 you.NOM were.2SG given king.DAT
 ‘You were given to the king.’ (Olafur Jonsson, p.c.)
- c. Mér þykir/?þykja/*þykjið [þið vera gáfaðir].
 me.DAT think.3SG/3PL/2PL you.NOM to be gifted
 ‘I consider you to be gifted.’ (Taraldsen 1994)
- d. Mér virðast/*virðist [þeir vera skemmtilegir].
 me.DAT think.3PL/3SG they.NOM to be interesting
 ‘It seems to me that they are interesting.’ (Sigurðsson 1989)

²³ George & Kornfilt (1981) are often cited for the claim that case and agreement are reflexes of the same relation.

- e. Mér virðist/*?virðast [stráknum líka þessir bílar].
 me.DAT seem.3SG/3PL the boy.DAT to like these cars.NOM
 ‘The boys seem to me to like these cars.’ (Watanabe 1993: 417–418)

There is also a certain class of verbs in Georgian that do not agree with a nominative object, for example as in (45a), though these verbs do agree with a nominative subject (45b) (Léa Nash, p.c.; cf. Aronson 1990:345). Thus the connection between nominative case and verb agreement does not hold in all cases. The issue of how to capture the relation between finite T and nominative Case is a complex one, which I leave aside here.

- (45) a. Nino-s çigneb-i da-e-ğarg-a.
 Nino-DAT books-NOM PV- ν +R-lose-AOR.3SG
 ‘Nino lost the books.’
 b. Çigneb-i da-e-ğarg-nen.
 books-NOM PV- ν +R-lose-AOR.3PL
 ‘The books are lost.’

We will maintain the view that a nominative object checks Case on R, not on T. This view appears to have desirable consequences. We have seen evidence that an object can shift to a second specifier of ν P. Let us assume that a shifted nominative object can likewise move to a second specifier of RP. If so, then the dative argument and shifted nominative argument are equidistant from T. However, only the dative argument can raise to the subject position (46).²⁴ This restriction follows from Case Identification, if we assume that the nominative object has already checked Case on R by the time T is added to the derivation. Otherwise, the nominative object should be able to raise and check Case on T instead.²⁵

- (46) a. [Honum] var gefin [ν P [ν P t [ν P bókin]]]].
 him.DAT was given.NOM the book.NOM
 ‘He was given the book.’

²⁴ If the DO-IO order is possible in the active, the DO can raise to the subject of the passive (Falk 1990). Only the DAT-ACC case combination allows reordering in the active, yielding a DAT-NOM combination in the passive. Some restrictions apply even in this combination, however, as (46b) shows.

²⁵ The argument here is not as strong as it might be, because I have seen no examples of the object-subject order with a dative subject, parallel to the example with a nominative subject in (27).

- b. * [Bokin] var gefin [_{VP} [_{RP} honum [_{VP} t]]]].
 the book.NOM was given.NOM him.DAT
 ‘The book was given to him.’ (Falk 1990)

Note that Icelandic passives allow Case suppression on *v* only, and not on R, as in American English. Thus the DO must check Case on R in a passive as well.

Further evidence that the quirky subject checks Case on T can be seen from expletive constructions in Icelandic. It has been claimed that an expletive like English *there* checks the EPP feature of T, while the Case feature of T is checked by the indefinite associate. In (47), the associate *sumum málfræðingum* has dative m-case, yet this argument presumably checks the Case feature of T. Note that the quirky argument is the indefinite associate even though the nominative argument *Jón* triggers verb agreement—singular in (47a), and plural in (47b) (Jonas 1998).

- (47) a. Það virðist sumum málfræðingum [_{TP} Jón vera duglegur].
 there seem-SG some linguists.DAT J.NOM be intelligent
 ‘Jon seems to some linguists to be intelligent.’
- b. Það virðast sumum málfræðingum [_{TP} þessir stúdentar vera duglegir].
 there seem-PL some linguists.DAT these students.NOM be intelligent
 ‘These students seem to some linguists to be intelligent.’

In fact, the quirky argument is the only possible associate in this structure; if it is definite, the structure is ill-formed, even if the nominative argument is indefinite (48). Although the verb agrees with the nominative argument, this argument checks Case on R, not on T, so it cannot act as the associate.

- (48) *Það virðast þessum málfræðingum [_{TP} margir stúdentar vera duglegir].
 there seem-PL these linguists.DAT many students.NOM be intelligent
 ‘Many students seem to these linguists to be intelligent.’ (Jonas 1998)

Where Case is suppressed on *v*, as in Icelandic, only the highest DP can raise to the subject position. However, if Case is suppressed on R, a lower argument can leapfrog over the DP that receives its theta-role from R. In some languages, leapfrogging is obligatory. In Albanian, for example, only the lower object of a passive ditransitive can raise to the subject position. What I will suggest in these cases is that the Case of the higher argument

must be checked on ν for morphological reasons, so only the lower argument can check Case on T.

(49) ν and R in Albanian ditransitives (and in Greek ditransitives with a DAT clitic)

	ν	R
Active	Case (DAT); theta	Case (ACC); inherent DAT m-case specification
Passive	Case (DAT)	EPP; inherent DAT m-case specification

Consider the Albanian examples below. In the active, the IO c-commands the DO, as is shown by the fact that an IO quantifier can bind a pronoun in the DO (50). In the nonactive, the opposite binding pattern holds (51) (Massey 1990, 1992).

- (50) a. Agimi ia dha secilit djalë pagën e tij.
 A.NOM CL give each boy.DAT pay.ACC his
 'Agim gave each boy his pay.'
- b. *Agimi ia ktheu secilin liber autorit të tij.
 A.NOM CL return each book.ACC author.DAT its
 'Agim returned to its author each book.'
- (51) a. Secili libër iu kthye autorit të tij t.
 each book.NOM CL returned.NACT author.DAT its
 'Each book was returned to its author.'
- b. *Secilit djalë iu dha t paga i tij.
 each boy.DAT CL gave.NACT pay.NOM his
 'Each boy was given his pay.'

The proposed derivation for (51a) is given in (52). The nominative object merges with V to check its theta-feature. R merges with the resulting VP. In the active, R has a Case feature, which is checked by attracting the Case feature of the DO. As noted above, when the Case feature on R is suppressed, it has an EPP feature. Recall that this feature requires Merge, and cannot be checked by the same argument that merges to check the theta-feature of R (the IO). As a result, the DO moves to a second specifier of RP. Thus, when passive ν is merged, there are two arguments in specifiers of RP, neither of which has checked Case. In the correct derivation, the IO checks Case by feature-attraction to ν , leaving the DO to check the Case and EPP features of T. Since the two arguments are

equidistant, however, locality cannot prevent *v* from checking the Case of the DO instead. I propose that in Albanian ditransitives, R specifies dative m-case on the argument that checks its theta-feature. Assuming that dative m-case can be checked by *v*, but not by T, the IO must check Case (and m-case) on *v*, while the DO raises to the subject position and checks Case on T. If the DO checks Case on R, and the IO on T instead, the m-case features of the IO cannot be successfully checked; the derivation crashes due to unchecked or mismatched m-case features on the IO and/or T.

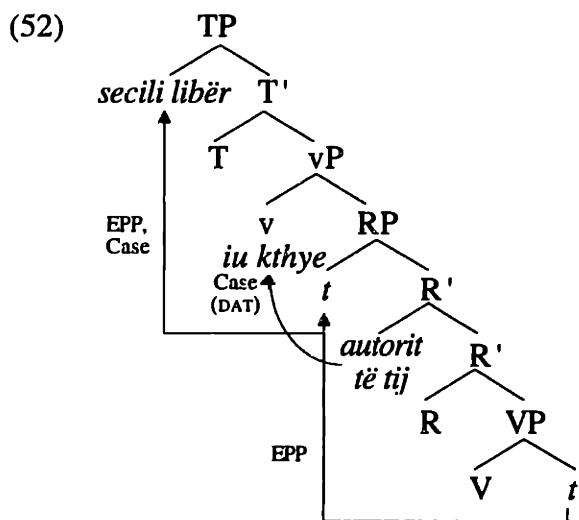

Recall that only the highest DP can check Case or EPP at a given stage in the derivation. Thus the DO cannot simply skip over the IO to the subject position in (52). The DO can raise to the subject position only by leapfrogging through the same checking domain as the IO. As discussed in section 1, two specifiers in the same checking domain are subject to Lethal Ambiguity. We predict that Lethal Ambiguity will prevent an anaphoric dependency between the raised DO and the IO in the Albanian passive. This prediction is confirmed (53).

- (53) a. $[_{TP} \text{Secili djalë } iu \text{ tregua } [_{VP} [_{RP} t \text{ babës të tij } [_{VP} t]]]]$
 each boy.NOM CL show.NACT father his.DAT
 ‘Each boy was shown to his father.’
- b. * $[_{TP} \text{Drita } iu \text{ tregua } [_{VP} [_{RP} t \text{ vetes } [_{VP} t \text{ (prej artistit)}}]]]]$
 Drita.NOM CL show.NACT self.DAT by the.artist
 ‘Drita was shown to herself by the artist.’

Unlike Chaga, which allows suppression of Case on either ν or R, Albanian allows suppression of Case only on R. In a passive where R specifies its theta-specifier as having dative m-case, suppressing Case/m-case on ν leads to ungrammaticality, since there is then no appropriate head to check the dative m-case of the IO. Again, unchecked or mismatched m-case features cancel the derivation. In some situations a dative m-case specification on R can be suppressed in the nonactive; I defer discussion of these examples to Chapters 3 and 4.

As noted in the discussion of the long passive in Chaga, the IO in a long passive cannot raise to spec- ν P, though its Case feature is attracted by ν . If the IO raises to spec- ν P, it is then the closest argument to T, so it blocks the DO from being attracted to spec-TP. The IO itself is ineligible to check the Case or EPP features of T, since it has already checked Case on ν . As a result, these features of T remain unchecked, and the derivation crashes.

A similar case of blocking can be seen in passive ditransitives in Modern Greek (Anagnostopoulou 1997, 1998). Well-formed passive ditransitives in Greek have a clitic or clitic-doubled IO, specified by R as having dative m-case.²⁶ The derivation is then the same as an Albanian passive ditransitive. In the passive, the Case feature of R is replaced by an EPP feature, which is checked by moving the DO to spec-RP. The IO checks Case and dative m-case by feature-movement to ν , and the DO raises again, this time to check Case and EPP on T (54). Anagnostopoulou argues that the dative clitic represents formal features of the IO, which raise to T. I proposed above that object clitics in French check Case in spec- ν P; in Greek, however, I assume that clitics check Case by Attract, rather than by movement to a specifier. The attracted features are spelled out in their head-adjointed position.²⁷

²⁶ Anagnostopoulou notes that what she calls dative case is morphologically identical to genitive case.

²⁷ The reason for this claim is that in Greek, unlike French, object clitics do not give rise to Lethal Ambiguity effects. See Iatridou (1988) and Chapter 3 for relevant facts and discussion. Anagnostopoulou argues that the clitic in Greek includes D-features, since clitic-movement affects binding relations.

- (54) a. To vivlio tu dothike [_t t [_t] apo tin Maria]].
 the book.NOM him.DAT was given by the M.ACC
 'The book was given to him by Mary.'
- b. To vivlio tu dothike [_t tu Janni [_t] apo tin Maria]].
 the book.NOM him.DAT was given the J.DAT by the M.ACC
 'The book was given to John by Mary.'

A dative IO is not necessarily doubled by a clitic (55). I take the absence of the clitic to indicate that the IO checks Case not structurally, by attraction to ν , but rather inherently, by merging with its theta-assigner.

- (55) (Tu) edosa tu Janni to vivlio.
 him.DAT gave-I the J.DAT the book.ACC
 'I gave the book to John.'

In this case, R has two Case features. One is checked under Merge with the IO, and the other is checked by attracting features of the DO. There is no way for the DO to check Case on a higher head, such as ν , because the IO intervenes between the DO and any head higher than R.

- (56) ν and R in Greek ditransitives with no DAT clitic

	ν	R
Active	theta	Case (ACC); inherent Case (DAT)
Passive	—	inherent Case (DAT)

In a passive, one of the Case features on R is suppressed. The remaining Case feature is specified as being checked by Merge (of the IO). As a result, Case Identification prevents the IO from raising out of spec-RP to check EPP. In order for the derivation to converge, therefore, the Case and EPP features of T must be checked by the DO.

However, R has no EPP feature.²⁸ The DO remains in a lower checking domain than the

²⁸ Although one Case feature of R is suppressed, the inherent Case feature remains. This remaining Case feature may be related to the absence of the EPP feature in the passive. Where suppressed Case on R is replaced by an EPP feature (i.e., in long passives), R has *no* Case features.

IO. There is no way for T to attract the DO past the IO, so its Case and EPP features remain unchecked, and the derivation crashes (57).

- (57) **To vivlio dothike tu Janni apo tin Maria.*
 the book.NOM was given the J.DAT by the M.ACC
 'The book was given to John by Mary.'

The DO cannot check the inherent Case feature of R instead of the IO, since this feature must be checked along with the theta-feature of R. The DO cannot check a second theta-feature after checking that of the base V, without giving rise to an uninterpretable structure. Thus when the clitic is absent, indicating that the IO checks inherent Case, the Greek ditransitive passive is ungrammatical. The derivation of (57) is shown in (58).

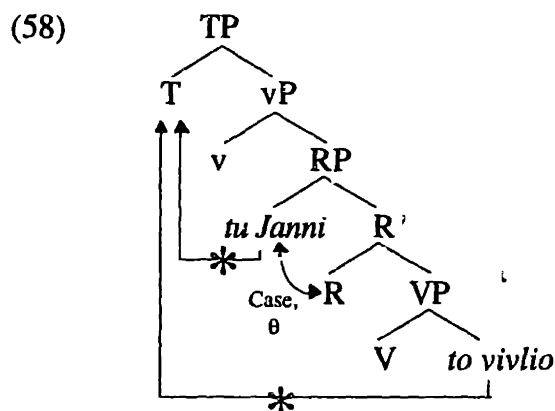

If the inherent Case feature on R could be suppressed instead of the structural Case feature, we would expect the passive to have roughly the same derivation as in English. The DO would check the remaining Case feature of R, while the IO would raise and check Case and EPP on T. Since there is no well-formed derivation corresponding to (56), we can conclude that only the structural Case feature of R can be suppressed in a Greek passive.

4 Equidistance and superraising revisited

In this chapter I have sketched an overview of the theory to be presented in the rest of this dissertation. Both Case and locality play crucial roles in my account of A-movement cross-linguistically. In this section, we will review two sets of facts that clearly illustrate the effects of Case and locality. The first set of facts concerns the influence of Case in

determining which argument(s) can raise out of a multiple specifier configuration. The second concerns the roles of Case and locality in blocking a new kind of “superraising” configuration.

As noted in section 2, there is evidence from Icelandic that Case, rather than locality, determines A-movement out of a multiple specifier configuration. On the basis of word order facts from Icelandic, Jonas (1996, 1998) argues that when the object of a transitive clause shifts to the specifier of its Case-checking head, it is above the merged (base) position of the subject. In the theory of Chomsky (1995, 1998), the Case-checking position of the object is in a specifier of the head that assigns a theta-role to the subject. Chomsky proposes that Merge always precedes Move, so the merged subject must be lower than the moved object.²⁹ Locality alone cannot ensure that the logical subject raises past the logical object to spec-TP; for this derivation to be possible, the two arguments must be treated as equidistant. On the other hand, the Case properties of the equidistant specifiers can be used to ensure that the logical subject raises to spec-TP. I have adopted the claim that the Case feature of an argument identifies the phrase to be pied-piped to a specifier to check EPP. This mechanism, Case Identification, blocks the object from raising to spec-TP after it has checked Case.

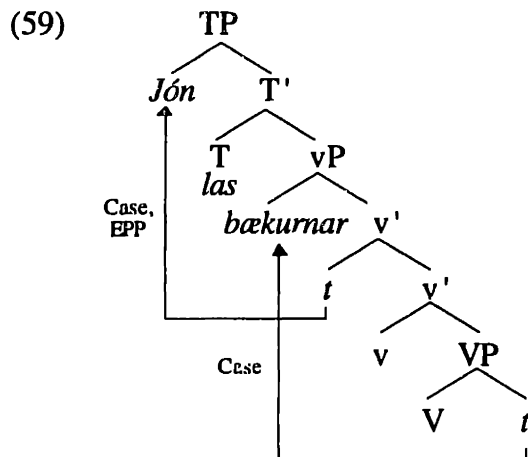

²⁹ The Case-checking object does not “tuck in” under the theta-checking subject (see footnote 20).

The typology of Case-checking and A-movement in the preceding section provides additional evidence that Case, rather than locality, regulates A-movement out of a multiple-specifier configuration. In fact, this evidence is independent of the claim that Merge precedes Move. Assuming that the moved and merged specifiers of the same head are always in the same c-command relation, locality cannot ensure movement of the higher argument in one case, and the lower argument in another. Case, or some other mechanism, is needed to distinguish between the two specifiers. As we saw in Icelandic, the merged argument in spec-*vP* (the logical subject) can be raised out of a multiple-specifier configuration, leaving the moved argument (the logical object) behind. The evidence from section 3 suggests that there are also cases in which the moved specifier can be raised out, leaving the merged specifier behind.

Example (59) can be contrasted with the Albanian passive (60), in which the DO moves into a specifier of RP, to check an EPP feature on R. R lacks Case in an Albanian passive, so the DO does not check Case in spec-RP. From this position, it can move on to spec-TP. In fact, this is the only alternative that yields a well-formed derivation. The m-case specifications of R require the IO to check Case and m-case on *v*. If the IO raises to spec-TP instead of the DO, the m-case specifications of the IO will not be checked successfully, and the derivation will crash.

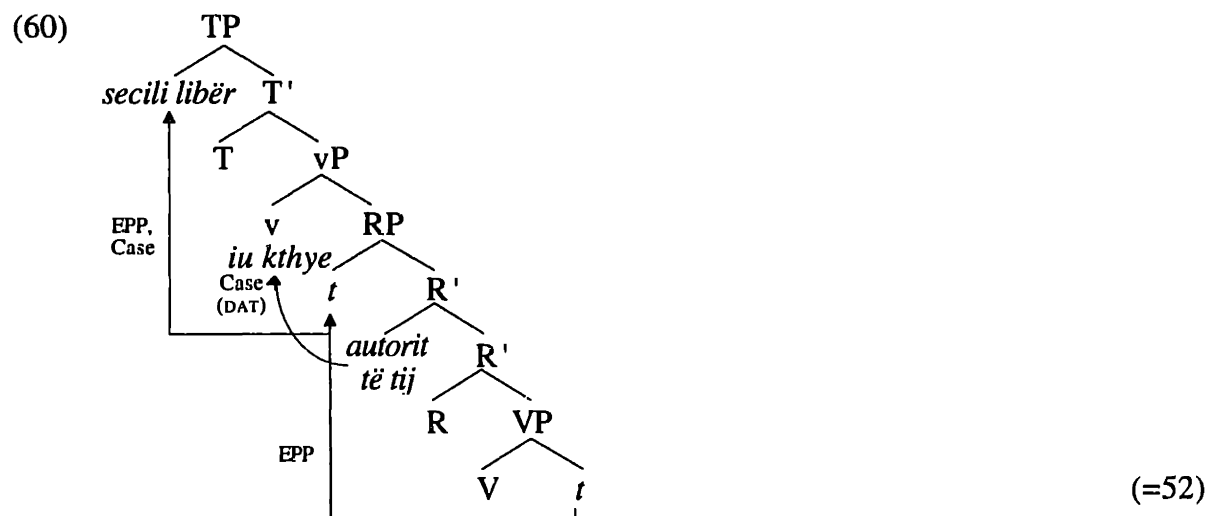

As we saw above, there is evidence that the DO moves into a specifier of RP. Under Attract F, the only way for a lower DP to be attracted past a higher DP is to leapfrog through a specifier of the same checking domain. Otherwise, the higher DP will block attraction of the lower one. Moreover, Lethal Ambiguity blocks an anaphoric dependency between this DP and the IO. Feature-attraction into the same checking domain and movement skipping over a checking domain do not interfere with anaphoric dependencies; the restriction applies only to arguments occupying specifiers of the same head.

It should be noted that the difference in attracting the merged specifier in (57) and the moved one in (58) does not arise merely from the distinction between RP and ν P. In some languages the merged specifier of RP does raise to the subject position, as we saw in English, Icelandic, and Chaga. Nevertheless, we do not observe the same range of alternations for ν P and RP. Generally, only the merged specifier of ν can raise to the subject position. In the story presented here, the possibility of raising the moved specifier of RP depends on R having EPP, but crucially not having Case. In a passive, R can lack Case, but still assign a theta-role to a DP specifier. A lower argument can be attracted to check an EPP feature on R, then on T, leapfrogging over the theta-specifier. By contrast, the Case feature of ν is generally suppressed only when ν lacks a DP external argument.³⁰ Thus there is generally no way for a DO to leapfrog over a DP external argument, to yield the “inverse” derivation.

Though Case may determine which of two equidistant arguments can raise further, locality also plays a crucial role in A-movement. there is some overlap in the explanatory power of Case and locality, since the most local argument for attraction is often the only one that has not yet checked Case. In some situations, however, an argument that has not

³⁰ There are apparently exceptions to this generalization, as in the Bantu “inverse” construction (Ndayiragije 1996, 1997; Zwart 1997). Here the direct object raises to the subject position triggering subject-verb agreement, although the clause contains an overt logical subject. This construction will be discussed in Chapter 2.

checked Case is “trapped” below one that has. A familiar example of this kind involves superraising out of a finite clause.

- (61) a. * [It] seems [_{CP} (that) [_{TP} *t* is likely [_{TP} Archy to have written a novel]]].
 b. * [Archy] seems [_{CP} (that) [_{TP} it is likely [_{TP} *t* to have written a novel]]].
 c. * Seems [_{CP} (that) [_{TP} it is likely [_{TP} Archy to have written a novel]]].

Case Identification prevents the higher argument from raising to check Case or EPP features in the matrix clause (61a), while locality blocks the lower argument from doing so (61b). As a result, the only possible derivation leaves both arguments in an embedded clause (61c). This derivation crashes, due to the uninterpretable Case and EPP features that remain unchecked.

Section 3 provides an additional case of ill-formed “superraising,” which does not involve movement across a finite clause boundary. Unless it is doubled by a clitic, an IO in a Greek ditransitive has inherent Case, which is checked via Merge with R. Because of Case Identification, this argument cannot be attracted out of spec-RP to check EPP. When R has a structural Case feature for a lower argument to check, the derivation is fine (62a). When the structural Case feature is suppressed, as in a passive, the DO is trapped below the IO without having checked Case (62b).

- (62) a. Edosa tu Janni to vivlio.
 gave-I the J.DAT the book.ACC
 ‘I gave the book to John.’
 b. * Dothike tu Janni to vivlio apo tin Maria.
 was given the J.DAT the book.NOM by the M.ACC
 ‘The book was given to John by Mary.’

Locality prevents T from attracting the DO, so the Case and EPP features of T also remain unchecked. Unchecked uninterpretable features violate Full Interpretation, so the derivation crashes.

5 Outline of the Thesis

In the account presented here, both locality and Case have crucial effects on A-movement. The remainder of this dissertation examines such effects in more detail. Chapter 2 shows a range of cases where two arguments occupy different checking domains, and the higher argument is the one that raises to an available subject position. In Chapter 3, I present cases where a lower argument raises past a higher one by leapfrogging through the same checking domain. This movement is in accord with locality, but gives rise to Lethal Ambiguity if an anaphoric relationship is established between the two arguments. Finally, Chapter 4 is devoted to cases where a lower argument skips over a higher one without moving through the same checking domain. Such movement is possible only when the higher argument has no features that can satisfy a requirement of the attracting head. I conclude by pointing out some remaining challenges for the theory presented here.

Chapter 2

Advancing

In the previous chapter, I set out the definition of syntactic movement that will be adopted here. By this definition, movement is driven by feature-attraction, and an attracting head attracts the most local argument with a feature that can check some feature of the head. In this chapter I present cases in which the argument that raises to the subject position is the DP argument that is merged highest in the structure. This is *advancing*, the simplest case of A-movement.

I will present several subcases of advancing. In the first subcase, both Case and locality require the highest argument to move to the subject position. A simple example of this kind is a transitive clause in English, in which *v* attracts just the Case (and phi-features) of the lower argument to check Case before T is merged, while the external argument has not yet checked Case. The external argument is then both the closest argument to spec-TP and the only argument that has not checked Case (1a). According to the mechanism of Case Identification, the Case feature of an argument identifies which phrase pied-pipes for checking EPP. Thus an argument cannot successfully check EPP if its Case feature has already been checked and deleted.

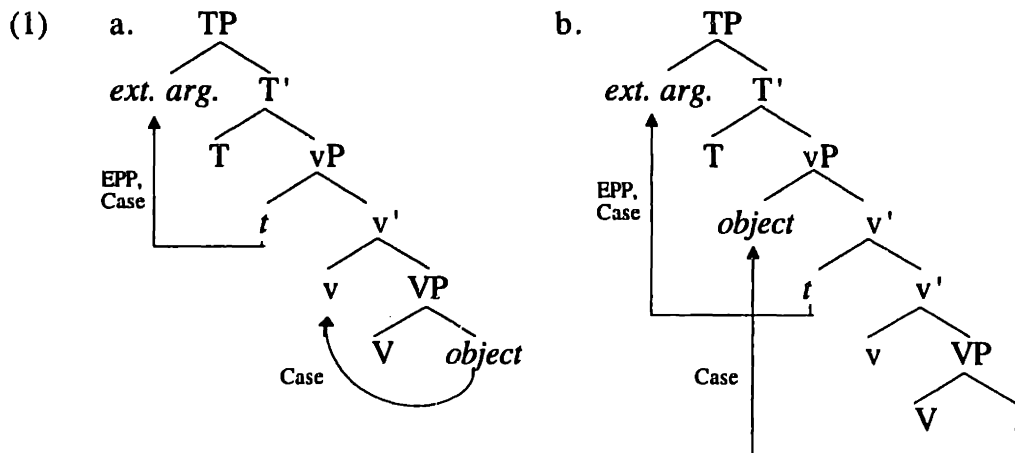

A second subcase of advancing (1b) arises when a lower argument checks Case by moving into the checking domain occupied by a higher argument. In this situation, locality does not determine which argument raises out, since the two arguments are equidistant for purposes of attraction. However, Case Identification prevents the argument with a checked Case feature from raising to check EPP. One example of this kind is a case of object shift in Icelandic, where a definite object can check Case by moving to spec- ν P, with the external argument checking the theta-feature of ν in another specifier of ν P, as in the example below. Since the object checks Case in spec- ν P, only the external argument can raise to check the EPP feature of T. It was suggested in Chapter 1 that when two arguments occupy specifiers of the same head, Lethal Ambiguity rules out an anaphoric dependency between them. We will explore this prediction at greater length in Chapter 3.¹

The final subcase to be discussed in this chapter is one in which only the features of the highest argument can be attracted, but Case Identification prevents this argument from moving. An example of this kind is the Greek ditransitive passive already discussed in Chapter 1. There I proposed that in Greek, unless the indirect object is a clitic or clitic-doubled, it checks Case inherently, via Merge with its theta-assigning head. As a result, although its D-feature is attracted to T, Case Identification prevents the DP from being identified as the phrase for pied-piping to spec-TP. EPP can only be satisfied by Merge, so the derivation crashes. T cannot attract the direct object across the more local indirect object, even though this lower argument has not checked Case.

¹ In cases like (1b), the lower argument moves to check Case. It was proposed in Chapter 1 that EPP can likewise attract a lower argument into the checking domain occupied by a higher argument. This proposal predicts a third subcase of advancing, in which a lower argument first moves into the same checking domain as a higher argument to check EPP, then has its Case feature attracted by a higher head. At this point, according to Case Identification, only the other argument—the one that originated higher—can advance to the subject position. I will discuss this subcase further in Chapter 3, Section 3.1.2.

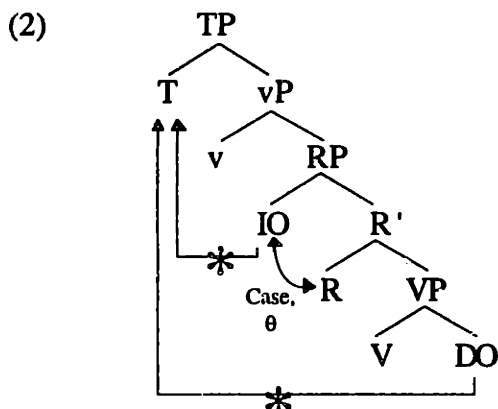

As noted, this chapter concerns cases in which the argument generated highest is attracted to the subject position. We will see two kinds of evidence for the structural position of the arguments before movement to spec-TP. One kind comes from correlations between movement to the subject position, and c-command in parallel cases without such movement. A second type of evidence for structural position comes from proposed semantic/syntactic universals. Evidence of both kinds will be presented for A-movement in a range of different clause types.

1 Transitives

I have claimed above that transitive clauses involve movement from an argument in the specifier of vP to the subject position in the specifier of TP. In this section, I review some of the evidence for this claim.

Familiar binding asymmetries indicate that the external argument is in a position structurally higher than the object. For example, a subject quantifier can bind a pronoun in the object (3a), and a subject antecedent can bind an object anaphor (4a). In each case, the opposite binding relation is impossible. Moreover, an R-expression in the subject can corefer with a pronominal object (5a), but coreference between a pronominal subject and an R-expression in the object gives rise to a Condition C violation.

- (3) a. Each boy_i treated his_i cat differently.
 b. *He_i treated each boy_i's cat differently.

- (4) a. My cat treats itself badly.
 b. *Itself treats my cat badly.
- (5) a. Elissa_i's cat treated her_i like a cockroach.
 b. *She_i treated Elissa_i's cockroach like a cat.

These asymmetries in binding and interpretation are enough to establish that the subject c-commands the object from its raised position in the specifier of TP. However, they do not show that the subject is *generated* above the object. It has been argued that the subject of a transitive clause is semantically (i.e., universally) “external” to the event described by the VP (Marantz 1984, 1997; Kratzer 1993, 1996). One type of evidence that has been used to argue for semantic constituency arises from the availability of special meanings within a certain syntactic domain. In a transitive clause, the verb and direct object can form a special meaning to the exclusion of the subject (6), but the subject and the verb cannot form a special meaning to the exclusion of the object, as in (7).

- | | | | |
|-----|---|-----|---|
| (6) | a. take a leap
b. take a leak
c. take a break
d. take the cake
e. take five
f. take cover, issue, heart... | (7) | a. The suicidal lemming took DP.
b. The elephant took DP.
c. The performers took DP.
d. That really takes DP.
e. Take DP!
f. You'd better take DP... |
|-----|---|-----|---|

This asymmetry has been taken as evidence that the logical subject is not a true argument of the verb, and so is generated external to the constituent containing the verb and its arguments (Marantz 1984).

Bresnan (1982:291) and Grimshaw (1990) point out that combining the subject last does not logically require that it should be excluded from the argument structure of the verb (the I-syntax). Rather, they note that the order of application of arguments can be specified in the verb's semantic representation. This point is taken up by Kratzer (1993, 1996), who argues that external arguments cannot be excluded from the domain of special meanings simply by specifying that they are semantically combined last. Kratzer notes that in certain theories of logical form (e.g. Davidson 1967, Parsons 1990), a transitive verb like *buy* is treated as a three-place predicates, taking as its arguments the event, the agent, and the

theme. A possible lexical representation of the verb would be as in (8a). If the special meanings of a verb could be defined over the arguments in its lexical entry, there would be no principled way to exclude the agent from their domain of application. Kratzer argues instead that the lexical entry for *buy* should look more like (8b). The external argument is added to the interpretation by syntactic combination with the verb and its other arguments.

- (8) a. *buy*: $\lambda x \lambda y \lambda e [\text{buying}(e) \ \& \ \text{Theme}(x)(e) \ \& \ \text{Agent}(y)(e)]$
- b. *buy*: $\lambda x \lambda e [\text{buying}(e) \ \& \ \text{Theme}(x)(e)]$

If the external argument is not an argument of the main verb, it must be the argument of some other head. Following the recent literature, I assume that an external argument is generated outside the verb phrase headed by the main verb, in the specifier of a light verb (Bowers 1993, Harley 1995, Kratzer 1996, Collins 1997, Nishiyama 1998). Marantz (1997) proposes that the light verb (*v*) defines the domain in which special meanings are possible (9).²

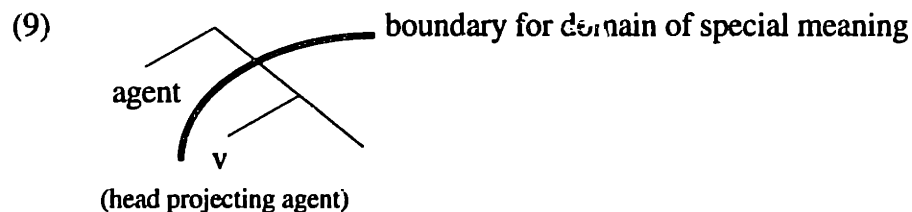

If the external argument is in the specifier of *v*P, it not only c-commands the internal argument(s), but also originates in a position more local to the attracting head T.

In accordance with locality, then, the external argument should advance to the subject position, provided the object remains in a lower checking domain. In English, for example, the external argument is attracted from the specifier of *v*P to the specifier of TP, and blocks any lower arguments from raising instead.

² Marantz (1984, 1997) points out that apparent clausal idioms such as *the shit hit the fan* do not involve an agent, and thus do not cross the boundary marked in (9).

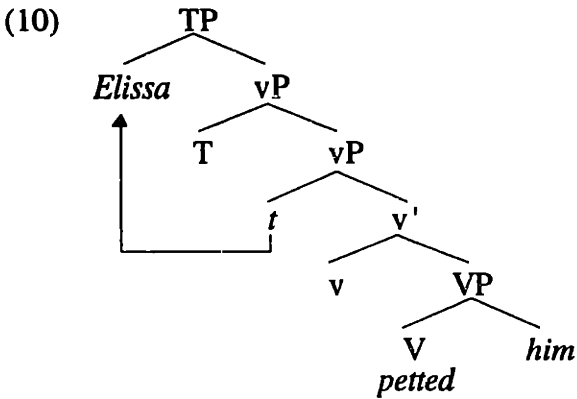

Case Identification also ensures that the direct object will not raise to spec-TP. By the time T is added to the derivation, the object has checked Case on v .

In some languages, the object can shift overtly to a position above the base position of the subject, as shown in (11) for Icelandic (Jonas 1998). When the subject is left in its base position, as in an expletive construction, the object shifts to a position above it. However, a shifted object cannot leapfrog over the external argument to the subject position.³

- (11) [_{CP} Það lásu [_{TP} *t*] [_{VP} [þessar bækur] aldrei neinir stúdentar [_{VP} *t* í fyrra]]].
 there read these books never any students last year
 'No students ever read these books last year.'

In this case, movement of the object to the subject position is ruled out by Case Identification alone. Having checked the Case feature of v , the object DP cannot be pied-piped to spec-TP to check the EPP feature of T. Since the external argument is equally local, and can check both the Case and EPP features of T, it is successfully attracted to spec-TP.

2 Double Object Constructions

In the previous section, we saw evidence that the subject of a transitive clause is generated in a higher checking domain than the object. C-command tests were of little use in

³ Jonas argues that the object can also shift to a position above the subject in Irish (McCloskey 1997), Breton (Schafer 1994), and Belfast English (Henry 1995), among other languages.

determining the base position of the subject, since they could be largely attributed to the fact that the subject c-commands the object from the specifier of TP. In double object constructions, however, the c-command relation between the two objects can be determined from the structure in the active voice. Assuming that the same c-command relations obtain in the passive counterpart, we can determine whether the higher or lower argument raises to the subject position of the passive.

2.1 Short passives

In some languages, only the higher argument can advance to the subject position in the passive of a double object construction. We will call such passives “short” passives, to be distinguished from “long” passives, where the lower argument leapfrogs to the subject position (see Chapter 3). According to the theory proposed here, a short passive can occur when the higher argument has an unchecked Case feature.

Binding asymmetries like those between subjects and objects also arise between direct and indirect objects (Barss & Lasnik 1986). For instance, an indirect object quantifier can bind a direct object pronoun, but not vice versa.

- (12) a. I read each author_i his_i book.
b. *I read its_i author each book_i.
- (13) a. I showed Mary herself in the mirror.
b. *I showed herself Mary in the mirror.
- (14) a. I read Tolstoy his most famous book.
b. *I read him_i Tolstoy_i's most famous book.

We can conclude that a DP indirect object c-commands the direct object. The opposite situation arises when the indirect object is a PP. In this case, the direct object c-commands the indirect object.

- (15) a. *I read his_i book to each author_i.
b. I read each book_i to its_i author.
- (16) a. *I showed herself to Mary in the mirror.
b. I showed Mary to herself in the mirror.

- (17) a. * I read it_i to the author of *War and Peace*_i.
 b. I read *War and Peace* to its author.

Barss & Lasnik provide a number of additional c-command tests, including anaphor and reciprocal binding, weak crossover, superiority, and negative polarity licensing.

These asymmetries have been taken to indicate that the two objects are generated in an articulated structure such as the one in (18a), rather than a flat structure like (18b) (Marantz 1993).

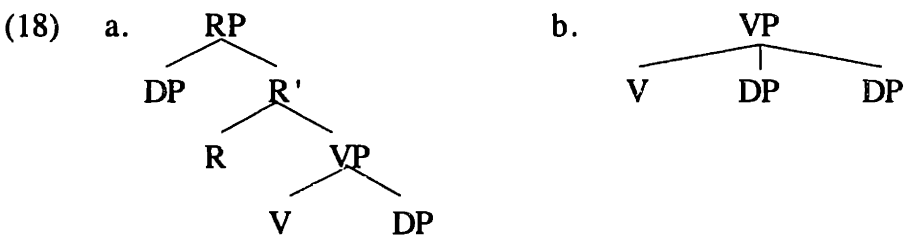

Barss & Lasnik suggest that asymmetries such as those in (12-14) may arise from differences in linear order, rather than in structural position (see also Jackendoff 1990, Larson 1990). However, cross-linguistic evidence suggests that structural position is the relevant factor. For example, in Albanian, an indirect object quantifier binds a direct object pronoun, but not vice versa, as shown in (19). Here it is impossible to tell whether linear order or c-command is the relevant factor.

- (19) a. Agimi ia tregoi secilit djalë babën e tij.
 Agim.NOM CL showed each boy.DAT his father.ACC
 'Agim showed each boy_i his_i father.'
- b. * Agimi ia tregoi babait të tij secilin djalë.
 Agim.NOM CL showed his father.DAT each boy.ACC
 'Agim showed his_i father each boy_i.'

However, Albanian also allows the direct object to scramble to an A-bar position to the left of the indirect object. The difference in linear order does not affect the options for quantifier-pronoun binding, which depends only on the highest A-positions of the arguments (20).

- (20) a. Agimi ia tregoi [secilit djalë] babën e tij t.
 Agim.NOM CL showed his father.ACC each boy.DAT
 ‘Agim showed each boy_i his_i father.’
- b. * Agimi ia tregoi [secilin djalë] babait të tij t.
 Agim.NOM CL showed each boy.ACC his father.DAT
 ‘Agim showed his_i father each boy_i.’ (Massey 1990)

Of course, c-command asymmetries alone do not motivate the assumption in (18a) that the two objects are generated in separate checking domains. Marantz (1993) argues that at least some indirect objects are semantically external to the event described by the VP, though not in precisely the same way as the external argument. Marantz proposes that a DP goal or benefactive argument is merged in the specifier of a light applicative verb, while a theme or patient is merged in the checking domain of the lower base verb. The term *applicative* is taken from the literature on Bantu languages. These languages have a highly productive use of what are known as “applied” verbs, which have an argument added to the clause and an affix added to the verb, which Marantz takes to be a verbal head involved in assigning a theta-role to the added argument. Such arguments include goals, benefactives, locatives, and instrumentals.

Marantz argues that a goal or benefactive is merged above the base VP for interpretive reasons: the event described by the base VP forms a separate compositional unit, denoting an event that is semantically prior to the effect on the goal or benefactive. By contrast, an instrumental argument can occur either above or below the theme, since the two can be simultaneously involved in a single event.⁴ This difference has consequences for Bantu double object constructions, as described in Marantz (1993), and can also be seen in other phenomena, such as the formation of adjectival passives in English.

⁴ The claim that these structures are semantically determined is equivalent to the claim that they are universal. It is of course not a priori obvious that an instrumental can be combined in a single event with the verb and direct object any more than a goal can.

- | | | | |
|------|----|--------------------------|---------------------------------|
| (21) | a. | hand-made cookies | 'cookies made with one's hands' |
| | b. | spoon-fed children | 'children fed with a spoon' |
| | c. | * children-baked cookies | 'cookies baked for children' |
| | d. | * boss-given flowers | 'flowers given to the boss' |

Passives incorporating instrumentals are fine (21a-b), while those incorporating benefactives are out (21c-d). Marantz argues that this contrast arises because an instrumental can be a complement of the verb, while goals and benefactives must be merged in the specifier of a higher applicative verb.⁵ If this view is correct, a goal or benefactive originates in a higher checking domain than the theme, as shown in (18a).

One case in which the higher argument raises to the subject position of a passive ditransitive can be seen in American English. As we saw in (12-14), a non-PP indirect object in English c-commands a direct object. In a passive, only the indirect object raises to subject position, blocking movement by a lower argument (22). If the indirect object is a PP, however, the direct object c-commands it, and so raises to the subject position of a passive.

- | | | |
|------|----|-------------------------|
| (22) | a. | We were given a book. |
| | b. | * A book was given us. |
| | c. | A book was given to us. |

Another possible view is that the PP in (22c) originates higher than the direct object, but is not eligible for attraction to T, so the direct object is the closest eligible argument for attraction. Under this view, the direct object raises overtly past the PP in the active *I gave a book to John*. This approach is taken by Takano (1997), among others. Nothing in my proposals rules out this possibility, but I leave the issue aside here.

A similar correlation between c-command and movement can be found in Danish ditransitives (Herslund 1986). The possessive anaphor in Danish generally takes the subject of the clause as its antecedent. However, many speakers also allow an indirect object to bind a possessive anaphor in the direct object, as shown below.⁶

⁵ Marantz notes that agent incorporation (e.g., in *God-given talent*) is possible for other reasons.

⁶ In addition to the facts cited here, which indicate c-command, indirect objects in Danish pattern with subjects in a number of other ways, for instance in preventing extraction out of complex NPs. Herslund (cont....)

- (23) a. Drengen viste mig sin bamse.
'The boy_i showed me his_i teddy-bear.'
- b. Filmen *Intermezzo* gav Ingrid Bergman sit folkelige gennembrud i Sverige.
'The film *Intermezzo* gave Ingrid Bergman her popular breakthrough in Sweden.'

Herslund notes several other phenomena supporting the view that the indirect object is structurally higher than the direct object, including the fact that the indirect object binds a reflexive *sig selv* within the direct object. Like English, then, Danish has the indirect object c-commanding the direct object in an active double-object construction. In the passive counterpart, only the indirect object can raise to the subject position.

- (24) a. Han blev tilbudt en stilling.
'He was offered a job.'
- b. *En stilling blev tilbudt ham.
'A job was offered to him.'

The same asymmetry between direct and indirect objects can be observed in certain Bantu ditransitive constructions as well. As noted above, the light applicative verb shows up in these languages as an affix on the verb, here glossed R. The examples in (25) are from Chicheŵa (Sam Mchombo, p.c.). (25a) shows a benefactive applicative, with a benefactive quantifier binding a pronoun in the direct object. The opposite binding pattern is not possible, as shown in (25b), indicating that the benefactive argument is structurally higher. If the applicative construction is not used, and the indirect object appears instead as a PP, it can contain a pronoun bound by a direct object quantifier, just as in English.

- (25) a. Ndi-na-mu-wereng-er-a buku lake mlembi ali yense.
1-PST-OP-read-R-FV book his author every
'I read for every author his/her book.'
- b. *Ndi-na-mu-wereng-er-a buku lili lonse mlembi wake.
1-PST-OP-read-R-FV book every author its
'I read every book for its author.'

(...cont.)

implies that the properties he attributes to subjects and indirect objects do not hold for direct objects, but I have not yet been able to test this implication.

- c. Buku lili lonse ndi-na-li-wereng-a kwa mlembi wake.
 book every 1-PST-OP-read-FV to author its
 'I read every book for its author.'

Word order facts in Chicheŵa can reflect c-command as well. Chicheŵa allows a benefactive argument to be doubled by a pronominal affix on the verb. When no doubling takes place, word order in the double object construction corresponds to c-command, again as in English.

- (26) a. Chitsîru chi-na-gúl-ír-a atsíkána mphâtso.
 fool SP-PST-buy-R-fv girls gift
 b. *Chitsîru chi-na-gúl-ír-a mphâtsó atsíkāna.
 fool SP-PST-buy-R-fv gift girls
 'The fool bought a gift for the girls.' (Alsina & Mchombo 1993)

The fact that the benefactive argument can be doubled in Chicheŵa has been taken as evidence that it has structural Case in the active (Baker 1988b, Alsina & Mchombo 1993, Bresnan & Moshi 1993, Marantz 1993).

The c-command asymmetry in Chicheŵa correlates with a movement asymmetry in the passive of a benefactive applicative. Like other Bantu languages, Chicheŵa shows agreement with different noun classes, as indicated by numerals in the glosses of (27). The higher benefactive argument raises to the subject position, triggering subject agreement on the verb, and blocking the lower direct object argument from moving and/or triggering subject agreement.

- (27) a. Atsíkāna a-na-gúl-ír-idw-á mphâtso (ndí chítsîru).
 2-girls 2S-PST-buy-R-PAS-FV 9-gift by 7-fool
 'The girls were bought a gift.'
 b. *Mphâtso i-na-gúl-ír-idw-á átsíkāna (ndí chítsîru).
 9-gift 9s-PST-buy-R-PAS-FV 2-girls by 7-fool
 'A gift was bought for the girls.' (Alsina & Mchombo 1993)

Under my proposals, the Case feature of v is suppressed in the passive, so the benefactive argument has an unchecked Case feature when T is merged. By locality and/or Case Identification, the benefactive argument raises to the subject position.

Advancing also arises in Tzotzil, a Mayan language of Mexico with ergative morphology. Aissen (1987) notes that several properties of the direct object in a transitive clause are assumed by the indirect object in a ditransitive clause. I will call these “primary” object properties. It should be noted that constructions with an indirect object in Tzotzil have an additional verbal affix, *-b(e)*. I have glossed this affix as R, since its distribution resembles that of the applicative affix in Bantu; I assume it is the morphological realization of the light verb involved in assigning a theta-role to the indirect object. Ergative and absolutive arguments in Tzotzil do not bear overt case marking, but the highly inflected verb includes affixes cross-referencing these arguments. Affixes cross-referencing the absolutive argument appear only when this argument is first- or second-person, and the ergative argument triggers a separate agreement marker.

- (28) a. **Ch-a-j-mil-be-ik.**
 ICP-2.ABS-1ERG-kill-R-PL
 ‘I’ll kill him/them **for you (pl).**’
 * ‘I’ll kill you (sg/pl) for him/them.’ (Laughlin 1977:131)
- b. 7i-y-ak’-be s-ba li mayoletike.
 CP-3ERG-give-R 3-self the police
 ‘The police gave it to themselves.’
 * ‘He gave himself to the police.’

In a transitive clause, the direct object triggers absolutive agreement on the verb. By contrast, note that in (28a), only the indirect object triggers absolutive agreement. The second-person plural argument can only be interpreted as the direct object, showing that the affixes in bold must cross-reference the benefactive. (28b) shows that only the indirect object can be bound by the subject. (28b) cannot have an interpretation involving coreference between the subject and the direct object. Again, if only a single direct object is present, it can be bound by the subject. In Aissen’s (1987) Relational Grammar approach, an indirect object such as this that takes on primary object properties is considered to have undergone 3-to-2 advancement. Marantz (1989) argues instead that primary object properties are associated with the object that occupies the higher structural position. I will continue to assume the structural account.

Under this view, the indirect object is higher than the direct object in Tzotzil. The fact that it triggers agreement on the verb also suggests that it has structural Case. As in the languages discussed above, this higher argument advances to the subject position of the passive. The benefactive triggers absolutive agreement on the verb, as shown in (29).

- (29) Ch-i-7ak'-b-at jun tzeb.
 ICP-1ABS-give-R-PAS a girl
 'I'm being given a girl.' (Laughlin 1977:66)

The first-person absolutive agreement in (29) can only be understood as cross-referencing the indirect object, so (29) cannot mean 'I'm being given to a girl.' The fact that the agreement is absolutive, rather than ergative, suggests that the direct object has not assumed primary object status. If it did so, this passive would be formally transitive, with an ergative subject and an absolutive direct object. Instead, the structure is formally intransitive, with the subject triggering absolutive agreement.

In this section, I have presented ditransitive constructions in which the argument generated higher checks Case on ν in an active clause, and on T in a (finite) passive clause. Case is suppressed on ν in the passive. This claim has implications for the lower object as well. If a Case feature were present on ν in the passive, we would expect the more local indirect object to be able to check it. Instead, however, this argument always raises and checks Case in spec-TP. Nevertheless, if all DPs are generated with a Case feature, the direct object must also check Case. Since no Case feature is available on ν in the passive, we conclude that this object checks Case on a lower head, namely R, which preserves its Case feature in the passive, at least in the examples discussed here. Thus *a book* checks Case on ν in (30a), and on R in (30b).

- (30) a. I read a book.
 b. I sent him a book.

A similar account is proposed by Ura (1996), following earlier work by Collins & Thráinsson (1995), Koizumi (1995), and others.

2.2 Passive alternations

So far we have mainly considered cases in which the indirect object is generated most local to the subject position. However, there are also cases in which the direct object can be in a higher A-position before movement to spec-TP. One example of this kind was the English double object construction in which the indirect object is in a PP (22c).

Another example can be seen in Icelandic. An indirect object that precedes a direct object in Icelandic c-commands it, as shown in (31). Here, the dative indirect object can bind a possessive anaphor in the accusative direct object, but not vice versa.

- (31) a. Ég hafði gefið konunginum ambáttina sína.
I.NOM had given the king.DAT the maidservant.ACC self's
'I had given the king, his, maidservant.'
- b. *Ég hafði gefið konungi sínum ambáttina.
I.NOM had given king.DAT self's the maidservant.ACC
'I had given her, king the maidservant,' (Collins & Thráinsson 1996)

In general, only the indirect object raises to the subject position of a passive, as shown below. This argument keeps its dative m-case even when it raises to the subject position, while the object is nominative and triggers verb agreement. Dative subjects will be discussed further in the next section.

- (32) a. Konunginum voru gefnar t ambáttir.
the king.DAT were given maidservants.NOM
'The king was given maidservants.'
- b. Henni var skilað t peningunum.
her.DAT was returned the money.NOM
'The money was returned to her.' (ZMT 1985)

In some cases, however, verbs associated with DAT-ACC case marking for the objects can also allow the opposite c-command relation as a marked option, as noted by Rögnvaldsson (1982) and discussed further by Zaenen, Maling & Thráinsson (1985, henceforth ZMT), Falk (1990), Holmberg (1991), Holmberg & Platzack (1995), Ottósson (1991), and

Collins & Thráinsson (1996).⁷ In this order, the direct object (DO) can bind a possessive anaphor in the indirect object (IO).

- (33) *Ég gaf ambáttina konungi sínum.*
 I.NOM gave the maidservant.ACC king.DAT self's
 'I gave the maidservant, to her, king.' (ZMT 1985)

There are certain restrictions on the DO-IO order. I will not be concerned here with the reasons behind these restrictions; the reader is referred to Falk (1990) for further discussion. Falk proposes that when the DO-IO order arises, the indirect object is actually a PP. This analysis assimilates the DO-IO structure to constructions where the direct object c-commands a PP indirect object, and only the direct object raises to the subject position, as in the English (22c). The main point of interest for our purposes is that only those constructions allowing the DO-IO order in an active clause allow the direct object to raise to the subject position of the corresponding passive.

Let us consider these restrictions in turn. First, the DO-IO order is possible only for ditransitive verbs with a dative indirect object and an accusative direct object. Icelandic also has ditransitive verbs with dative or genitive case on the direct object, and dative or accusative case on the indirect object. Such verbs do not permit the DO-IO order. Only double-object constructions with a dative indirect object and an accusative direct object in the active counterpart allow the direct object to raise to the subject position in the passive counterpart. Thus the same restriction holds in both cases.

Secondly, the DO-IO order is possible only when the indirect object is a stressed, non-pronominal DP. Likewise, movement of the direct object to subject position is possible only if the indirect object is stressed and non-pronominal.

- (34) a. **Ég gaf bókina honum.*
 I.NOM gave the book.ACC him.DAT
 'I gave the book to him.'

⁷ Collins & Thráinsson show that the DO-IO order does not arise from object shift of the direct object over the indirect object. Unlike object shift, the DO-IO order is compatible with an auxiliary verb and with indefinite arguments. It could still be supposed that the lower argument raises over the higher one by some other process. Falk (1990) and Ottósson (1991) give opposing arguments on this point.

- b. Bókin var gefin Olafi/*honum.
 the book.NOM was given.NOM Olaf.DAT/him.DAT
 ‘The book was given to Olaf/him.’

Finally, the DO-IO order is impossible with certain kinds of direct objects. Falk argues that these are cases where the direct object and the verb form a compositional semantic unit that affects the interpretation of the indirect object.

- (35) a. Ég gaf bókina/*áminningu einhverjum stráka.
 I.NOM gave book.ACC/remind.ACC some boy.DAT
 ‘I gave a book/*a reminder to some boy.’
- b. Ég syndi bókina/*umhyggju einhverjum stráka.
 I.NOM showed book.ACC/concern.ACC some boy.DAT
 ‘I showed the book/*concern to some boy.’

Such objects cannot raise to the subject position in the passive, just as they cannot be higher than the indirect object in the active.

- (36) a. Bókin/*Áminning var gefin einhverjum stráka.
 the book.NOM/remind.NOM was given.NOM some boy.DAT
 ‘The book/*A reminder was given to some boy.’
- b. Bókin/*Umhyggja var synd einhverjum stráka.
 the book.NOM/concern.NOM was shown.NOM some boy.DAT
 ‘The book/*Concern was shown to some boy.’

Thus, although there appear to be “symmetrical” passives in Icelandic, there is evidence that these passives do not involve leapfrogging of the lower argument past the higher one. Rather, the DO appears to raise to the subject position only when it is generated above the IO.

In this section we have seen evidence for advancing in double object constructions from a wide range of languages. When Case is suppressed on ν in a passive, the Case feature of the higher argument goes unchecked. Locality and/or Case Identification then ensure that this argument raises to the subject position. As we will see later in this chapter and in Chapter 3, ditransitive passives show considerable typological variation regarding which argument raises to the subject position. I attribute this variation to the proposal that, unlike ν , R can check Case or m-case inherently, or can inherently specify the m-case of its

theta-checker. These options allow a range of possibilities for movement to the subject position.

3 Dative Subjects

As noted in the discussion of Icelandic, not all subjects have the nominative m-case usually associated with an argument that checks Case on T. The m-case feature of some subjects is determined in the theta-position, rather than in the Case-checking position. ZMT (1985) argue that such “quirky” subjects are indeed true syntactic subjects. Like nominative subjects, dative subjects in Icelandic undergo raising under ECM (37a), antecede subject-oriented reflexives (37b), and immediately follow the verb under topicalization (37c), as well as having other subject properties.

- (37) a. Ég tel þeim hafa verið hjalpað i profinu.
'I believe them to have been helped in the exam.'
- b. Honum var oft hjalpað af foreldrum sínum/*hans.
'He was often helped by his parents.'
- c. I profinu var honum vist hjalpað.
'In the exam was he apparently helped.'

In Chapter 1, I proposed that both quirky and nominative subjects Case and EPP on T. however, a quirky argument checks m-case inherently—that is, when it checks a theta-feature. Because agents appear never to have quirky Case, it has been proposed that dative subjects are not generated in a specifier of the same head as an agentive external argument, namely ν ; rather, I will assume that they are generated in a specifier of R, in a checking domain below ν P. A nominative lower argument, if one is present, checks Case on R. Thus constructions with a dative subject are essentially the same as normal transitives, for purposes of Case and locality: the higher (here, dative) argument has an unchecked Case feature, so locality and/or Case Identification ensures that it is attracted to subject position even if the lower (here, nominative) argument first raises into the same checking domain to check Case.

The quirky experiencer of a raising construction in Icelandic also raises to the subject position. Suppose that the clausal complement of a raising verb is infinitival; I assume that the structure is as below.

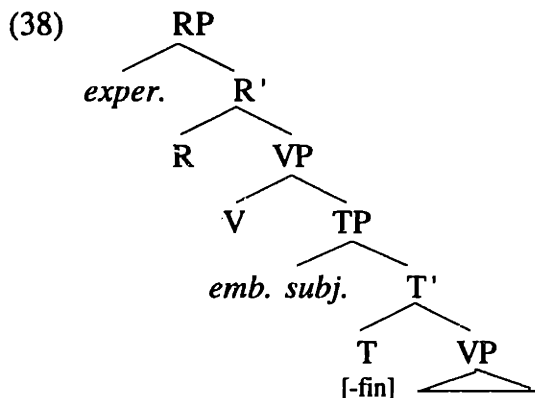

This structure is similar to that of a double object construction, except that the lower object is an infinitival clause (TP) rather than a DP. The experiencer is the higher argument, in the specifier of RP. I assume that the syntactic subject of an infinitival clause is in the specifier of TP.

Although the experiencer has quirky dative m-case in Icelandic, it does move to the subject position of the raising clause. The subject of the embedded infinitival can raise to the subject of a matrix clause (39a). However, if the matrix clause contains an experiencer, it is the experiencer that raises to subject position (39b). Thráinsson (1979) points out a number of properties indicating that the nominative argument in such cases is not the subject. Although it can appear to the left of the verb, in this position it is interpreted as a fronted topic (39c). Other constituents can also appear in this topicalized position, including adverbs and PPs.

- (39) a. Haraldur virðist [t hafa gert þetta vel].
 H.NOM seems to have done this well
 'Harald seems to have done that well.' (Andrews 1982)
- b. Mér virðist t [Haraldur hafa gert þetta vel].
 me.DAT seems H.NOM to have done this well
 'Harald seems to me to have done that well.'

- c. Haraldur virðist mér [*t* hafa gert þetta vel].
 H.NOM seems me.DAT to have done this well
 ‘Harald seems to me to have done that well.’ (Thráinsson 1979:426)

Moreover, unlike a raised subject, the nominative argument cannot occur in the preverbal position of an ECM clause (40a). By contrast, the dative argument can occur in this position (40b). If no higher dative argument is present, the nominative argument does occur in this position, where it receives accusative case (40c).

- (40) a. *Jón telur [Harald virðast mér hafa gert þetta vel].
 J.NOM believes H.ACC to.seem me.DAT to.have done this well
 ‘Jon believes Harald to seem to me to have done this well.’
- b. Jón telur [mér virðast Haraldur hafa gert þetta vel].
 J.NOM believes me.DAT to.seem H.NOM to.have done this well
 ‘Jon believes Harald to seem to me to have done this well.’
- c. Jón telur [Harald virðast hafa gert þetta vel].
 J.NOM believes H.ACC to.seem to.have done this well
 ‘Jon believes Harald to seem to have done this well.’

These examples demonstrate that the local experiencer argument moves to the subject position of a raising clause in Icelandic, blocking movement by the embedded subject. There is typological variation in raising constructions, to be discussed later in this dissertation. This variation results in part from the options for Case and case-checking, and in part from the options for Case suppression in raising clauses. Further variation results from the possibility of generating an experiencer within a PP.

Like Icelandic, Albanian also has dative experiencers. Quantifier-pronoun binding relations can be used to determine which argument occupies a higher A-position. The examples in (41) show that a quantificational dative experiencer can bind a pronoun in the nominative object, but not vice versa. These judgements hold regardless of word order.

- (41) a. Secilit djalë i kujtohet baba i tij.
 each boy.DAT CL remember father.NOM his
 ‘Each boy remembers his father.’
- b. *Secili djalë i kujtohet babes të tij.
 each boy.NOM CL remember father.DAT his
 ‘His father remembers each boy.’

Evidence for dative subjects can also be found in Georgian. The dative argument in (42a) is the subject, as can be seen from the fact that it can bind the nominative direct object. The opposite binding relation is impossible, as shown in (42b) (Harris 1981). Marantz (1989) proposes that dative experiencers in Georgian are added to the structure by means of a light verb, *R*, often morphologically realized as *u-*. This affix also appears in the presence of a dative indirect object.

- (42) a. Vano-s tavis tav-i u-qvars.
V.-DAT self-NOM R-loves
‘Vano loves himself.’
- b. *Tavis tav-s vano u-qvars.
self-DAT V.-NOM R-loves
‘Himself loves Vano.’

Other binding evidence supports the view that the dative argument is above the nominative one. (42) shows an example of binding in Georgian involving the complex anaphor (*tavis*) *tav* ‘(self’s) self.’ Georgian also has a possessive anaphor, *tavis*. This anaphor can also be bound only by an argument in a higher A-position. For example, the nominative subject of an active transitive clause can bind a possessive anaphor in the accusative direct object (43a).⁸ However, if the possessive anaphor appears in the subject, it cannot be bound by a direct object to its right (43b). This contrast is shown below.

- (43) a. Nino tavis deida-s akeb-s.
N.NOM self’s aunt-DAT praise-PRES
‘Nino_i is praising her_i aunt.’
- b. ??Tavis deida nino-s akeb-s.
self’s aunt.NOM N.-DAT praise-PRES
‘Her_i aunt is praising Nino_i.’

An object can be scrambled to an A-bar position above the subject and appearing to its left (Nash 1995, McGinnis 1995). The subject can still bind a possessive anaphor in an object scrambled to this position, as shown in (44a), since it still c-commands a trace of the object. There is also evidence that the direct object can occupy an A-position above the

⁸ Accusative and dative m-case are morphologically collapsed in Georgian. However, *R* appears with (dative) indirect objects and experiencers, and not with (accusative) direct objects (cf. Marantz 1989).

subject: an object in a higher position, on the left, can bind a possessive anaphor in the subject.

- (44) a. [Tavis_i deidas] nino_i t akebs. ‘Nino_i is praising her_i aunt.’
 b. Ninos_i [tavis_i deida] t akebs. ‘Her_i aunt is praising Nino_i.’

Exactly the same facts hold for dative-subject constructions. If the nominative object occupies a position below the dative subject, the subject can bind a possessive anaphor in the object, but the object cannot bind a possessive anaphor in the subject. If the object scrambles to an A-bar position above the subject, a possessive anaphor embedded within it can still be bound. Finally, if it occupies an A-position above the subject, it can in turn bind into the subject.

- (45) a. Vano-s tavis_i deida u-qvar-s.
 V.-DAT self’s aunt.NOM R-love-PRES
 ‘Vano_i loves his_i aunt.’
 b. ??Tavis deidas vano u-qvar-s.
 self’s aunt-DAT V.NOM R-love-PRES
 ‘His_i aunt loves Vano_i.’
- (46) a. [Tavis_i deida] vanos_i t uqvars. ‘Vano_i loves his_i aunt.’
 b. Vano [tavis_i deidas] t uqvars. ‘His_i aunt loves Vano_i.’

I have assumed that the dative argument in these cases is generated in spec-RP, above the nominative argument. Evidence for this claim can be found in Georgian and Japanese malefactive constructions. A malefactive dative argument in Georgian is associated with the same agreement pattern as any other dative subject, as distinct from that of a dative object. The key difference is shown in (47).

- (47) a. Deideb-s gela u-qvar-t.
 aunts-DAT G.NOM R-love.PRES-PL
 ‘The aunts love Gela.’
 b. Deideb-s gela ecxubeba(*-t).
 aunts-DAT G.NOM fight.FUT(-PL)
 ‘Gela will fight with the aunts.’

The plural suffix *-t* on the verb indicates that the dative experiencer is the subject (47a).⁹ A third-person argument is associated with *-t* only if it is a dative subject; *-t* is not associated with a dative third-person object, as in (47b).

The plural *-t* is triggered by a malefactive dative argument, as shown below. These are cases in which the malefactive argument is added to an unaccusative structure, generally marked by the affix *i-*, which I assume is unaccusative *v*, following Nash (1995). When R and unaccusative *v* are both present, the combination is spelled out as *e-*.

- (48) a. Deideb-s nino da-e-*q*arg-a-t.
 aunts-DAT N.NOM PreV-R+UNACC-lose-AOR-PL
 ‘The aunts had Nino lost on them.’
- b. Dedeb-s švileb-i da-e-*ç*r-a-t.
 mothers-DAT sons-NOM PreV-R+UNACC-cut-AOR-PL
 ‘The mothers had the sons wounded on them.’

Further evidence that the dative argument is the subject is that the nominative argument fails to trigger number agreement, as it would if it were the subject. In (49a), the single nominative argument raises to the subject position, giving rise to plural subject agreement on the verb. In (49b), the dative argument raises to the subject position, blocking the nominative argument from raising to the subject position, and even from triggering number agreement on the verb.¹⁰

- (49) a. Bavšveb-i da-i-*q*arg-nen.
 children-NOM lost-UNACC-AOR.3PL
 ‘The children are lost.’
- b. Deideb-s bavšveb-i da-e-*q*arg-a-t.
 aunts-DAT children-NOM lost-UNACC+R-AOR.3SG-PL
 ‘The aunts had the children lost on them.’

⁹ When the *-t* suffix appears with first- and second-person arguments, it is part of a pronominal clitic spelled out as a circumfix on the verb (Nash-Haran 1992). If the same is true here, then *-t* is clitic-doubling the dative argument. Alternatively, Noam Chomsky (p.c.) suggests this may be a rare instance of a verb agreeing with an argument that checks m-case inherently, contrary to the predictions of George & Kornfilt (1981).

¹⁰ Constructions of this kind were brought to my attention by Léa Nash. Similar cases are also mentioned in the corrected 1991 edition of Aronson’s grammar. Note that the tense/aspect marker can show *person* agreement if the object is first- or second-person. This situation can be contrasted with that of nominative objects in Icelandic, which in some contexts trigger number agreement, but not the person agreement associated with a nominative subject.

This suggests that the nominative object is checking case on malefactive R, which is not associated with the same kind of agreement.¹¹

Japanese adversity passives provide evidence that malefactives are generated higher than themes (Kubo 1990, McGinnis 1998). In the Georgian examples we have seen, the malefactive argument is added to an unaccusative construction, *X be lost* or *X be wounded*. In the Japanese adversity passive, a malefactive argument can also be added to a clause with an external argument (50b).

- (50) a. Suugaku-no sensei-ga Jiroo-o home-ta.
 math-GEN teacher-NOM J.-ACC praise-PST
 'The mathematics teacher praised Jiro.'
- b. Taroo-ga suugaku-no sensei-ni Jiroo-o home-rare-ta.
 T.-NOM math-GEN teacher-DAT J.-ACC praise-PAS-PST
 'Taro had the math teacher praise Jiro on him.' (Kubo 1990)

The malefactive not only bears nominative case, but also can bind the subject-oriented anaphor *zibun*, as shown in (51a). *Zibun* cannot be bound by a non-subject, such as the *by*-phrase *Taroo-ni* in the direct passive (51b). Note that the malefactive is not the only argument that can bind *zibun* in (51a); the agent can also do so.

- (51) a. Taroo-ga Hanako-ni zibun-no heya-de uta-o utaw-are-ta.
 Taro-NOM Hanako-DAT self-GEN room-at song-ACC sing-PAS-PST
 'Taro_i had Hanako_j sing a song in his/her_j room on him.'
- b. Hanako-wa Taroo-ni zibun-no oya-no moto-ni nokos-are-ta.
 Hanako-TOP Taro-DAT self-GEN parent-GEN care-in leave-PAS-PST
 'Hanako_j was left by Taro in her/*his_i parents' care.'

As we have seen, the presence of an external argument blocks a lower argument from becoming the subject, a generalization which is apparently not subject to typological

¹¹ Some additional evidence that the malefactive argument is a subject comes from facts relating to focus and word order in Georgian. Nash (1995) shows that, in general, the immediately preverbal position contains existentially asserted material. For example, the object is interpreted as unmarked new information in the SOV order. However, the subject differs from the object in that it need not be existentially focused in the immediately preverbal position, as in the SVO order. In the order OSV, the subject has contrastive rather than existential focus. In DAT-NOM-V examples with a malefactive argument, like (51b), the nominative argument is interpreted as unmarked new information, like an object, rather than contrastively focused, like a subject (Léa Nash, p.c.). According to this evidence, then, the dative malefactive argument is the subject.

variation. However, the added malefactive argument in (51a) does become the subject. Unless there is some reason why the generalization breaks down in this case, we can conclude that the malefactive argument is added above the external argument. The facts in (51) thus suggest that the structure is biclausal, with the agent as the subject of the lower clause and the malefactive as the subject of the higher one.¹²

The Japanese adversity passive has certain similarities to *let-* and *make-*causatives (52). In causatives of both kinds, the long-distance subject-oriented reflexive *zibun* can have as its antecedent either the causer/“letter” or the causee/“lettee” (Kitagawa 1986).

- (52) a. Calvin-wa Hobbes-o zibun-no kuruma-de paatii-e ik-ase-ta
 C.-TOP H.-ACC self-GEN car-by party-to go-CAUS-PST
 ‘Calvin, made Hobbes, go to the party in his_{ij} car.’
- b. Calvin-wa Hobbes-ni zibun-no kuruma-de paatii-e ik-ase-ta
 C.-TOP H.-DAT self-GEN car-by party-to go-CAUS-PST
 ‘Calvin, let Hobbes, go to the party in his_{ij} car.’ (Harley 1995)

These facts have been taken as evidence that causatives are biclausal. For Harley (1995), a biclausal structure is one with two EventP projections—*vP* projections, in our terms—having the two possible antecedents for *zibun* as their specifiers. Since the same binding options hold in adversity passives, I conclude that the Japanese adversity passive also has two *vP* projections. We can represent both structures as in (53), where *v* stands in for a causative, permissive or malefactive verb.

¹² The malefactive subject cannot bind an anaphoric argument in Japanese (i) or Georgian (ii), perhaps for semantic / pragmatic reasons. It can, however, bind the possessive *zibun* in Japanese or *tavis* in Georgian (not shown). Thanks to Kazuko Yatsushiro and Takako Aikawa for discussion of the Japanese facts.

- (i) *Taroo-ga zibun-ni Jiro-o home-rare-ta.
 T.-NOM self-DAT J.-ACC praise-PAS-PST
 Taro had himself praise Jiro on him.’
- (ii) *Deideb-s tavianti tav-i daekarg-a-t.
 aunts-DAT selves-NOM lost-AOR.3SG-PL
 ‘The aunts had themselves lost on them.’

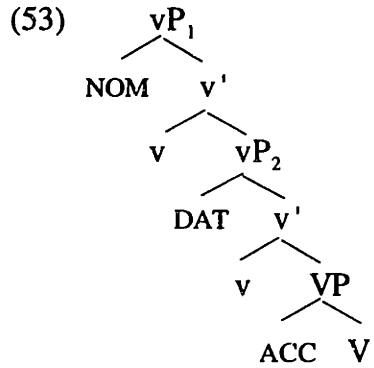

Japanese adversity passives differ in some respects from the Georgian malefactive constructions we have been considering. Recall that the malefactive dative argument in Georgian occurs in an unaccusative clause with a single nominative argument, not with a lower transitive clause, as is possible in Japanese adversity passives. We may suppose that the Georgian adversity constructions discussed above are monoclausal, by contrast with the biclausal adversity passives in Japanese. Otherwise, however, we expect the same structural relation between the malefactive and the verb phrase denoting the event that adversely affects it. If our account of Japanese adversity passives is correct, the malefactive argument is merged outside this verb phrase. Oehrle & Nishio (1981) argue that the structure of adversity constructions is semantically determined and thus universal. If so, the malefactive argument should always be merged outside the event that adversely affects it—even in a monoclausal adversity construction, as in Georgian. Under this view, Georgian unaccusatives with a malefactive argument constitute another case of advancing, with the higher malefactive argument checking Case and EPP in spec-TP.

4 Absolute Locality

The cases considered so far in this chapter involve the highest argument advancing to the subject position. In these cases, the highest argument not only is attracted by T, but also pied-pipes into a specifier of TP. In this section I will present cases in which the highest argument is attracted by T, but cannot pied-pipe to check EPP because it has already checked Case. Nevertheless, it does block a lower argument from being attracted instead.

These examples are analogous to the superraising violations discussed in Chapter 1 (e.g. **It seems that t is likely Archy to have written a novel*). In such cases, a DP that has checked Case in spec-TP (*it*) cannot be attracted to check EPP in a higher clause, but also blocks movement of a lower argument that has not checked Case (*Archy*). The superraising violations to be presented in this section do not involve attraction out of a finite clause, but rather attraction of a DP that has checked inherent Case.

Let us begin by considering raising constructions. Recall that raising in Icelandic involves movement of the highest argument to the subject position. If no experiencer is present in the raising clause, the highest argument is the subject of the embedded clause, as in (54a). If an experiencer is present in the matrix clause, it raises to the subject position (54b).

- (54) a. Haraldur virðist [*t* hafa gert þetta vel].
 H.NOM seems to have done this well
 ‘Harald seems to have done that well.’
- b. Mér virðist *t* [Haraldur hafa gert þetta vel].
 me.DAT seems H.NOM to have done this well
 ‘Harald seems to me to have done that well.’ (Thráinsson 1979:426)

I have proposed that, although the dative experiencer checks its m-case inherently when it checks the theta-feature of R, it checks Case by attraction to a higher head. When T is merged in the derivation of (54b), the Case feature of the experiencer has not yet been checked. Thus when the EPP feature of T attracts the D-feature of the experiencer, the whole DP can pied-pipe into spec-TP. Meanwhile, attraction of the embedded subject to the matrix subject position in (54b) is blocked both by locality and by Case Identification, since this argument checks Case on R before T is merged in the derivation.

In a number of languages, however, the situation is different. In French, raising an embedded subject to the subject position can also be blocked by an intervening experiencer. However, advancing the experiencer itself leads to a crashing derivation. Consider the

examples in (55).¹³ The embedded subject can raise, as in (55a). If an experiencer intervenes, the embedded subject is blocked from raising, as in (55b). The experiencer itself also cannot raise to the subject position (55c).

- (55) a. Jean semble [_t avoir du talent].
 J. seems to have of talent
 ‘Jean seems to have talent.’
- b. ??Jean semble à Marie [_t avoir du talent].
 J. seems to M. to have of talent
 ‘Jean seems to Marie have talent.’
- c. * A Marie semble _t [Jean avoir du talent].
 to Marie seems J. to have of talent
 ‘Jean seems to Marie have talent.’

In Chapter 1 I proposed that the difference between Icelandic and French can be attributed to the Case properties of R. In Icelandic, as I have said, R checks the m-case of the theta-checking DP. In the French examples with an experiencer (55b-c), R checks the Case feature of the experiencer inherently when it merges in spec-RP. As a result, when T attracts the D-feature of the experiencer, Case Identification prevents the DP from pied-piping to spec-TP, and the EPP feature cannot be checked. Nevertheless, the lower argument cannot be attracted to spec-TP. I conclude that in these examples, there is no EPP feature on R that can attract the embedded subject into the checking domain occupied by the experiencer. The embedded subject presumably fails to check Case at all, in fact, since a Case feature is generally suppressed in a nonactive. The experiencer checks inherent Case, so I assume that the Case feature suppressed is a structural Case feature on R. Thus neither EPP nor the Case feature of the embedded subject is checked, and the derivation crashes.

¹³ Speakers disagree on the grammaticality of examples like (55b). My own consultants are divided on this point, and different judgements are reported in Rouveret & Vergnaud (1980:146) and Chomsky (1995:305). For speakers who accept (55b), I assume that these structures are like the parallel examples in English, discussed in Chapter 4. My thanks to Marie-Claude Boivin, Marlyse Baptista, Marie-Hélène Côté, Johan Rooryck and Philippe Schlenker for helpful discussion of these facts.

Another source of ungrammaticality in (55) might be that an overt subject is left within the infinitival clause, an option that appears to be impossible in certain languages.¹⁴ Even if the embedded clause is finite, however, the experiencer cannot raise to the subject position in French, as shown in (56a). On the other hand, the experiencer is grammatical if it remains below the subject position, as in (56b), where the EPP and Case features of T are checked by an expletive. Here the experiencer checks Case in spec-RP, the expletive in the matrix spec-TP, and the embedded subject in the embedded (finite) spec-TP. On the other hand, if the embedded clause is non-finite, the embedded subject again has nowhere to check Case, and the derivation crashes (56c).

- (56) a. * A Marie semble [que Jean a du talent].
 to M. seems that J. has of talent
 'It seems to Marie that Jean has talent.'
- b. Il semble à Marie [que Jean a du talent].
 it seems to M. that J. has of talent
 'It seems to Marie that Jean has talent.'
- c. * Il semble à Marie [Jean avoir du talent].
 it seems to M. J. to have of talent
 'It seems to Marie that Jean has talent.'

Since the embedded clause in (56a) is finite, there is no problem with an overt embedded subject. However, only the expletive can satisfy the the EPP requirements of T. If the expletive is absent, the result is ungrammaticality.

Parallel facts also hold in Italian (Rizzi 1986).¹⁵ The Italian equivalent of (55) yields the same judgements as in French: the embedded subject of an infinitival can raise to the subject position of the matrix clause (57a). If the matrix experiencer is a (postverbal) DP, it blocks the lower subject from raising, and the derivation crashes (57b). If the experiencer itself raises, the derivation crashes nonetheless (57c).

¹⁴ Marantz (1991) argues that this gap is due to restrictions on the distribution of the expletive, rather than a Case violation. The restriction he proposes is that expletive *it* cannot be inserted if movement is possible. This restriction would rule out *Il semble [Jean avoir du talent]*, but not (55c), which lacks an expletive. In support of this view, note that Icelandic allows an overt subject to remain within an infinitival in (54b).

¹⁵ I also thank Sveva Besana and Michela Ippolito for their Italian judgements.

- (57) a. Gianni sembra [*t* fare il suo dovere].
 G. seems to do the his duty
 'Gianni seems to do his duty.'
- b. ??Gianni sembra a Piero [*t* fare il suo dovere].
 G. seems to P. to do the his duty
 'Gianni seems to Piero to do his duty.'
- c. *A Piero sembra *t* [Gianni fare il suo dovere].
 to P. seems G. to do the his duty
 'Gianni seems to Piero to do his duty.'

These facts have the same analysis as in French: the experiencer blocks the embedded subject from raising, but cannot itself check the EPP feature of T. However, it should be pointed out that a difference arises between Italian and French if the embedded clause is finite. In (58a), with a finite embedded clause, the experiencer *a*-phrase occurs in the preverbal position. My consultants judge (58a) as grammatical, by contrast with its French counterpart in (55c).

- (58) a. A Piero sembra *t* [che Gianni faccia il suo dovere].
 to P. seems that G. does the his duty
 'It seems to Piero that Gianni does his duty.'
- b. Sembra a Piero [che Gianni faccia il suo dovere].
 seems to P. that G. does the his duty
 'It seems to Piero that Gianni does his duty.'
- c. A Piero Gianni sembra *t* [*t* fare il suo dovere].
 to P. G. seems to do the his duty
 'To Piero, Gianni seems to do his duty.'

If the experiencer occupies the subject position in (58a), then the ungrammaticality of its counterpart with an infinitival complement cannot be attributed to the impossibility of raising the experiencer to the subject position. However, it should be noted that the equivalent to (58a) with a postverbal experiencer is (58b), where the subject position is left unpronounced. This again contrasts with the French equivalents in (56), where the subject position must be occupied by the overt expletive *il*. Since the subject position is left

unpronounced in (58b), it is reasonable to suppose that the same occurs in (58a), with the *a*-phrase in a higher A-bar position. The experiencer occupies an A-bar position above the subject in (58c), so it ought to be able to do likewise in (58a).¹⁶ Thus we can assume that the Case and EPP features of T are again checked by an expletive, but in Italian this expletive is phonologically null. We may suppose that the expletive can also check Case and EPP of T in (57c), but the embedded subject is still left with an unchecked Case feature, so the derivation crashes.

Raising constructions with an experiencer in Spanish also lead to a crashing derivation (Torrego 1996, Soriano 1997).

- (59) a. Este taxista parece [*t* estar cansado].
 this taxi driver seems to be tired
 ‘This taxi driver seems to be tired.’
- b. Me parece [que este taxista esta cansado].
 me.DAT seems that this taxi driver is tired
 ‘It seems to me that this taxi driver is tired.’
- c. * Este taxista me parece [*t* estar cansado].
 this taxi driver me.DAT seems to be tired
 ‘This taxi driver seems to me to be tired.’

Raising from the embedded clause is fine if there is no experiencer, as in (59a), and an experiencer is fine if the complement clause is finite, so that no raising occurs, as in (59b). Raising with an experiencer, however, is ungrammatical even if the experiencer is a clitic, as in (59c). We can apply the same analysis to these facts as to those from French. The experiencer checks Case inherently, so it cannot be attracted to spec-TP. A lower argument also cannot be attracted past the experiencer. On the other hand, I will propose in the next chapter that once a clitic has adjoined to T, it cannot block attraction of a lower argument to

¹⁶ The well-formedness of raising with a topicalized experiencer seems to pattern with the well-formedness of raising with a clitic experiencer, to be discussed in Chapter 3. *Wh*-movement of the experiencer also permits raising, as shown in the well-formed French example below.

- (i) A qui est-ce que Jean semble *t* [*t* avoir du talent]]?
 to whom is it that J. seems to have of talent
 ‘To whom does Jean seem to have talent?’

spec-TP. Even if an experiencer clitic checks Case in spec-RP, it should still cliticize to T, and therefore should not block attraction of a lower argument to spec-TP. Spanish, however, has clitic-doubling; in fact an overt experiencer in a raising construction is always clitic-doubled (Torrego 1996). I propose that the experiencer clitic always doubles a full DP, even if this DP is phonologically null. Attraction of the embedded subject in (59c) is thus blocked, not by the clitic, but by the null experiencer DP. Since the Case of this experiencer is checked inherently, it cannot itself raise to spec-TP.

An experiencer can also block raising of the embedded subject in Modern Greek (Anagnostopoulou 1997). In (60b), for example, a dative DP experiencer blocks raising out of an embedded predicate.

- (60) a. O Jannis fenete [t eksipnos].
 the J.NOM seems intelligent
 ‘John seems intelligent.’
- b. *O Jannis fenete tis Marias [t eksipnos].
 the J.NOM seems the M.DAT intelligent
 ‘John seems to Mary intelligent.’

(60a) shows that the embedded subject can raise to the subject of the higher clause, if no experiencer is present. Anagnostopoulou proposes that the intervening dative experiencer in (60b) blocks raising under feature-based locality. In our terms, T attracts the D-feature of the experiencer, but the DP cannot pied-pipe to spec-TP, so the EPP feature goes unchecked and the derivation crashes. As we will see in the next chapter, examples like (60b) are grammatical in Greek if the experiencer is a clitic or clitic-doubled.

Anagnostopoulou shows that the same situation arises in Greek ditransitives, as noted in Chapter 1. It can be demonstrated that the indirect object c-commands the direct object in Modern Greek. Although the direct object may precede the indirect object linearly, a quantifier in the direct object may not bind a pronoun in the indirect object, as shown in (61a). However, the opposite binding pattern is acceptable, as shown in (61b).

- (61) a. *?Estila to kathe vivlio_i tu sigrafea tu_i.
 sent.I the every book.ACC the author.DAT its
 'I sent its author every book.'
- b. Estila tu kathe sigrafea_i to vivlio tu_i.
 sent.I the every author.DAT the book.ACC his
 'I sent every author his book.'

This asymmetry indicates that the indirect object is generated higher, in the specifier of the light verb R, while the direct object is the complement of the base verb.

As we saw in the Greek raising constructions, the EPP feature of TP cannot be checked by an argument that has already checked Case. Assuming that the indirect object checks Case inherently on R when it merges, the ill-formedness of the passive in (62a) is explained. This construction is ill-formed even if neither argument raises overtly to the subject position (62b). As in the French and Italian cases with an expletive subject and a nonfinite complement clause (56c, 57c), we can assume that such examples are ill-formed because the lower argument cannot check Case. Even if (62a) contains an expletive checking the Case and EPP features of T, the Case feature of the direct object goes unchecked.

- (62) a. *?To vivlio dothike tu Janni apo tin Maria.
 the book.NOM was.given the J.DAT by the M.ACC
 'The book was given to John by Mary.'
- b. *?Dothike tu Janni to vivlio apo tin Maria.
 was.given the J.DAT the book.NOM by the M.ACC
 'The book was given to John by Mary.'

A dative argument that checks inherent Case can also lead to a crashing derivation in Greek unaccusatives. The unaccusative construction in (63a) has only a single 'theme' argument, which raises to the subject position. The same verb can also occur with a dative argument, which is interpreted as a recipient. If the dative argument is a full DP, the sentence is ungrammatical, as illustrated in (63b). As in the passive ditransitive, the dative argument cannot move to the subject position, yet it blocks T from attracting the lower argument. Again, the same contrast holds even if the dative argument remains in its base position overtly, as in (63c), since the theme is unable to check Case.

- (63) a. To gramma irthe t me megali kathisterisi.
 the letter.NOM came with a big delay
 ‘The letter came with a big delay.’
- b. *To gramma irthe tis Marias t me megali kathisterisi.
 the letter.NOM came the Mary.DAT with a big delay
 ‘The letter came to Mary with a big delay.’
- c. *Irthe tis Marias to gramma me megali kathisterisi.
 came the Mary.DAT the letter.NOM with a big delay
 ‘The letter came to Mary with a big delay.’

Greek also has double-object constructions with a PP indirect object. In passives and unaccusatives with the indirect object in a PP, the direct object can raise to the subject position.¹⁷

- (64) a. Edosa to vivlio s-ton Janni.
 gave-I the book to-the J.
 ‘I gave the book to John.’
- b. To vivlio dothike s-tin Maria.
 the book was given to-the M.
 ‘The book was given to Mary.’
- b. To gramma irthe s-tin Maria me megali kathisterisi.
 the letter.NOM came to-the Mary.ACC with a big delay
 ‘The letter came to Mary with a big delay.’

We can assign to these examples the structure already proposed for cases in other languages with a PP indirect object. The PP is generated below the nominative argument, which is then the most local argument to the subject position. Since this argument has an unchecked Case feature, it can successfully move to check the EPP feature on T. Similarly, an unaccusative has a well-formed derivation if the indirect object is a PP.¹⁸

¹⁷ Anagnostopoulou (1998) notes that the PP indirect object may either precede or follow the direct object. Here linear precedence seems to correlate with c-command; a quantifier PP can bind a pronoun in a direct object to its right, and a quantifier direct object can bind a pronoun in a PP to its right. The same is not true if the indirect object is a DP; in this case it tends to precede the direct object, but even when the opposite order is possible, the binding relations are not reversed.

¹⁸ Anagnostopoulou (1997) reports that a PP experiencer is not possible at all in Greek raising constructions. I take this fact to result from selectional properties of the verb.

- (65) To gramma irthe s-tin Maria me megali kathisterisi.
 the letter.NOM came to-the Mary.ACC with a big delay
 'The letter came to Mary with a big delay.'

All things being equal, we expect double-object passives to behave in the same way in French and Italian. This would mean that an indirect object DP with inherent Case blocks the direct object from raising to subject position, but cannot itself check the EPP feature of T.

The examples in (66) illustrate the French double object construction. As in Greek, the indirect object cannot raise to the subject position of the passive.

- (66) a. Philippe a offert un cadeau à Michel.
 P. has given a gift to Michel
 'Philippe gave a gift to Michel.'
- b. *A Michel a été offert un cadeau.
 to M. has been given a gift
 'Michel has been given a gift.'

(66b) suggests that the indirect object cannot check the Case or EPP features of T, like the experiencer in a raising construction. This view is supported by the observation that an indirect object is blocked from raising to the subject position even when there is no other potential subject in the clause. The examples in (67) show an unergative verb with an indirect object. Impersonal passives of unergatives are possible in French, as shown in (67b). In this example, the EPP and Case features of T are checked by the expletive. If the expletive is absent, the indirect object cannot check the Case or EPP features of T, so the derivation crashes (67c).

- (67) a. Le juge procédera à une enquête.
 the judge will proceed to an inquiry
 'The judge will conduct an inquiry.'
- b. Il sera procédé à une enquête.
 it will be proceeded to an inquiry
 'An inquiry will be conducted.'
- c. * (A) une enquête sera procédé(e).
 to an inquiry will be proceeded
 'An inquiry will be conducted.'

As these examples show, French resembles Greek in that an indirect object cannot be attracted to the subject position. However, French does allow the direct object to raise to the subject position. Examples like (68a) suggest that the *à*-phrase can spell out a PP as well as a quirky DP (cf. Rouveret & Vergnaud 1980). The same case arises in Italian (68b).

- (68) a. Un cadeau a été offert à Marie.
 a gift has been given to M.
 'A gift was given to Mary.'
- b. Gianni è stato affidato a Maria.
 G. has been entrusted to M.
 'Gianni was entrusted to Maria.'

As in Greek, a PP indirect object seems to be generated below the direct object. Snyder (1992) reports that an indirect object quantifier can precede the direct object in French and bind a pronoun in it, as in (69a). However, a direct object quantifier can also precede and bind a pronoun in the indirect object (69b). In fact, my consultants prefer (69b). Again, the facts of Italian are parallel.

- (69) a. Jean a attribué à chaque mot_i son_i symbole.
 J. has attributed to each word its symbol
 'Jean attributed to each word its symbol.'
- b. Jean a attribué chaque mot_i à son_i symbole.
 J. has attributed each word its symbol
 'Jean attributed each word to its symbol.'
- (70) a. Sveva ha attribuito a ciascuna parola_i il proprio/suo_i simbolo.
 S. has attributed to each word the own/its symbol
 'Sveva attributed to each word its symbol.'
- b. Sveva ha attribuito ciascuna parola_i al proprio/suo_i simbolo.
 S. has attributed each word to the own/its symbol
 'Sveva attributed each word to its symbol.'

These facts suggest that either argument can c-command the other, as in the parallel constructions for Icelandic and English, discussed above. When the direct object c-commands the (PP) indirect object, it can move freely to spec-TP.

5 Summary

In this chapter, I have presented cases of advancing. Advancing can occur when the highest argument has an unchecked Case feature, so that it can check both the Case and EPP features of T. I have argued that in the cases presented here, movement to the subject position correlates with c-command and semantic compositionality: the argument generated in the highest checking domain is the one that raises, while raising of a lower one is blocked by locality and/or Case Identification. The cases presented in Section 4 suggest that locality must be respected, even when the resulting derivation crashes. These “superraising” violations constitute new evidence that locality plays a role in A-movement.

Less direct evidence for locality can be found in the contrast between leapfrogging and skipping, to be presented in the following chapters. I will argue that one DP can be attracted past another DP only by leapfrogging through the same checking domain. Lethal Ambiguity then ensures that the two arguments cannot be linked by an anaphoric dependency. On the other hand, if the highest argument is not a DP, a lower argument can skip over it without first occupying the same checking domain. Note that if Case alone were responsible for determining which argument raises to the subject position, there would be no reason to distinguish between movement past DP arguments that have checked Case and movement past non-DP arguments. In neither case would the higher argument be eligible to check Case, so in both cases the lower argument should simply raise to the subject position. In fact, however, locality prevents a lower DP from being attracted past a higher DP, unless it first moves into the checking domain occupied by this higher DP. Examples of this kind will be the topic of the next chapter.

Chapter 3

Leapfrogging

This chapter is devoted to cases in which a lower argument leapfrogs over a higher one by moving through the same checking domain. A case of this kind is shown in (1). In an active double object construction in Albanian, the indirect object c-commands the direct object, so a direct object quantifier cannot bind a pronoun in the indirect object (1a). In the passive, however, the direct object raises to the subject position, where it c-commands the indirect object. The binding relation that was ruled out in the active is permitted in the passive (1b).

- (1) a. * Agimi ia ktheu secilin liber autorit të tij.
 A.NOM CL return each book.ACC author.DAT its
 'Agim returned to its author each book.'
- b. Secili libër iu kthye autorit të tij t.
 each book.NOM CL returned.NACT author.DAT its
 'Each book was returned to its author.'
- (Massey 1992)

In the previous chapter, I argued that a lower argument cannot move to the subject position by first checking Case in the checking domain occupied by the higher argument. In this situation, Case Identification blocks the lower argument from moving on to check EPP. In this chapter, we will see that a lower argument can leapfrog over a higher one by first moving into the same checking domain to check an EPP feature, as shown in (2).

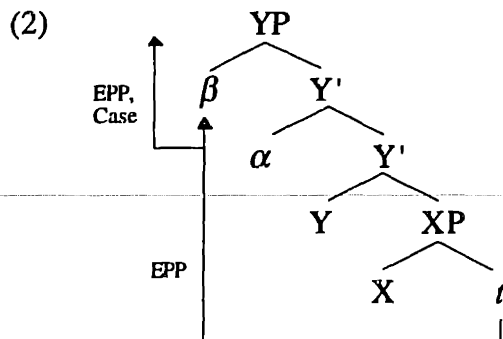

As we will see, the argument generated higher (α) can check Case by Attract, without moving into a higher checking domain. Once the argument generated lower (β) moves into the same checking domain, the two DPs are equidistant. Since β does not check Case in spec-YP, it can be attracted further to check EPP and Case. However, leapfrogging configurations are subject to the restriction on the distribution of anaphors we have called Lethal Ambiguity: if one argument leapfrogs over another, no anaphoric dependency can be established between them.

Before we can discuss leapfrogging to the subject position, however, I will argue that leapfrogging does indeed involve movement into the checking domain occupied by a higher element. In Section 1 of this chapter, I present evidence for this view from A-scrambling in Japanese. In Section 2, I show that arguments occupying specifiers of the same head at some stage in the derivation are subject to Lethal Ambiguity. We then return in Section 3 to leapfrogging in movement to the subject position. Finally, in Section 4, I argue that Lethal Ambiguity also arises when a lower argument raises into the checking domain occupied by a higher argument (e.g. to check Case), and the higher argument raises to the subject position.

1 A-Scrambling

A-scrambling provides us with independent evidence for the connection between leapfrogging and Lethal Ambiguity. A-scrambling does not involve Case or EPP checking, but can create new binding relations. It is a separate operation from A-bar scrambling (Mahajan 1990), which instead changes word order without affecting the range of available options for binding. An A-scrambled argument can also raise to a higher A-position. A classic case of A-scrambling arises in Hindi, where an object can scramble over a subject via either A-movement or A-bar movement (Mahajan 1990).¹ The examples in (3) show the

¹ Mahajan's judgements differ from those reported in Srivastav (1993) and Jones (1993), where only subject-oriented reflexive anaphors are possible. Binding in Hindi will be discussed further in Section 2.3.

effect of scrambling an object to an A-position above the subject. From below, an object quantifier cannot bind a pronoun within the subject (3a). However, if the object scrambles to a position above the subject, it can bind into the subject, as shown in (3b). If the object could only undergo A-bar scrambling, we would expect (3b) to be ungrammatical, as a weak crossover violation.

- (3) a. * Unkii_i bahin sab-ko_i pyaar kartii thii.
 their sister everyone love do.IMP.F be.PST.F
 ‘Their_i sister loved everyone_i.’
- b. Sab-ko_i unkii_i bahin *t* pyaar kartii thii.
 everyone their sister love do.IMP.F be.PST.F
 ‘Their_i sister loved everyone_i.’

Hindi also allows A-bar scrambling to a position above the subject, as shown in (4). These examples illustrate that long-distance scrambling is A-bar movement. When an object scrambles out of a finite embedded clause to a position above the matrix subject, it cannot bind into this subject, as shown in (4a). If the object could undergo A-movement to this position, binding would be possible, just as in (4b). Binding is ruled out because there is no way for the object to undergo long-distance A-movement into the higher clause, and binding from an A-bar position is impossible. Note that the scrambled object can bind the subject of its *own* clause, even if it undergoes long-distance scrambling into a higher clause (4b). This example shows that the object can first A-scramble within its own clause, then A-bar scramble into the higher clause.²

- (4) a. * Sab-ko_i uskii_i bahin-ne socaa [(ki) raam-ne *t* dekhaa thaa].
 everyone his sister thought that Ram saw be.PST
 ‘His_i sister thought that Ram had seen everyone_i.’
- b. Sab-ko_i raam-ne socaa [(ki) *t* uskii_i bahin-ne *t* dekhaa thaa].
 everyone Ram thought that his sister saw be.PST
 ‘Ram thought that his_i sister has seen everyone_i.’

² Thanks to Rajesh Bhatt for discussion of these examples. As in English, it is slightly odd, but possible, to use the possessive pronoun in the matrix subject to corefer with the embedded subject (*raam-ne*), but the bound variable reading is impossible.

Another familiar instance of A-scrambling arises in German (Webelhuth 1984, 1989, Grewendorf & Sternefeld 1990). German is a verb-second language, in which various different types of elements can occupy the preverbal “topic” position. If this position is occupied by an adverb, the subject usually precedes the direct object. However, the object can A-scramble to a position above the subject, as shown in (5).

- (5) a. * Vermutlich haben seine Kinder jeden gesehen.
 presumably have.3PL his children everyone.ACC seen
 ‘Presumably, everyone,’s children have seen him.’
- b. Vermutlich haben jeden seine Kinder *t* gesehen.
 presumably have.3PL everyone.ACC his children seen
 ‘Presumably, everyone,’s children have seen him.’

When a direct object quantifier remains below the subject, it cannot bind a pronoun in the subject. When it scrambles above the subject, however, binding is possible.³

The first question that arises with A-scrambling is how it is possible under the locality condition on Attract. We can ask, for example, why the subject permits the object to scramble past it in the German and Hindi examples above. One possible answer is that A-scrambling is not subject to locality. This approach is suggested by the view taken in Saito (1989) and Takano (1997); however, Richards (1997b) provides arguments that A-scrambling does obey locality, as we will see below. A second proposal, which I will adopt, is that A-scrambling involves movement of a lower argument into the checking domain occupied by the higher argument. An argument in the specifier of a given head cannot block movement of a lower argument to a second specifier of that head. Moreover, once the lower argument has scrambled into the same checking domain as the higher one, it can leapfrog over it to a higher position.

The derivation I will propose for the cases above is given in (6). The direct object first checks Case by Attract to *v*. There is no feature of either *v* or of the object itself to

³ There appears to be some variability in these judgements. Reportedly, at least for some speakers, (5b) is acceptable only if *jeden* is heavily stressed. Thanks to Martin Hackl, Uli Sauerland, and Susi Wurmbrand for judgement and discussion of these examples.

force pied-piping into a specifier of ν P, so Attract alone suffices for Case-checking. The external argument is attracted to check the Case and EPP features of T. At this point, I propose that a scrambling feature on T (Scr) attracts the direct object to a higher specifier of T.⁴ I assume that Scr, like EPP, is satisfied only by Merge.⁵ Scr cannot attract the subject, since a head cannot attract an argument already in its specifier. Thus attraction of the object to an A-position above the subject does not violate locality.

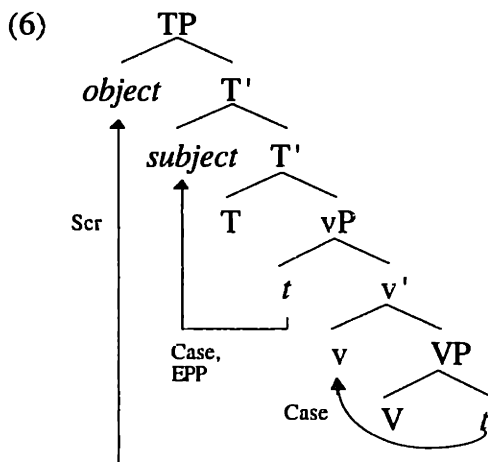

Note that under this proposal, an argument that has checked Case can nevertheless raise to an A-position. Since Case Identification applies only to EPP-movement, and not to A-scrambling, the object can move to check Scr on T even though its Case and phi-features have already been attracted to ν .⁶

A few remarks are in order about the proposed derivation. I have suggested that the feature on T that motivates A-scrambling is a feature distinct from Case and EPP, namely Scr. Miyagawa (1997) argues instead that the attracting feature is Case. He proposes that the heads checking the Case features of the subject and object (in our terms, ν and T) can fuse in the overt syntax in Japanese. When fusion occurs, the subject and the shifted object

⁴ Richards (1997b) argues that movement to multiple specifiers of the same head “tucks in,” while here instead we see the second attracted argument moving into a higher specifier than the first. This point is raised directly below, and addressed in detail in Section 1.2.

⁵ As far as I know, merging an expletive to satisfy Scr does not lead to a convergent derivation, probably because the expletive (or its associate) is left with an unchecked Case feature.

⁶ Chomsky (1995) proposes a similar derivation for *wh*-movement of an object in English, though *wh*-movement is to the specifier of a head higher than T (C). An object *wh*-moved to spec-CP need not leapfrog through spec-TP, since C attracts its *wh*-feature, which a (non-*wh*) subject lacks.

check Case in multiple specifiers of the fused head. However, according to Takano (1997), elements other than DP can A-scramble to a position above the subject. The examples in (7) show a scrambled PP binding a possessive anaphor in the subject.⁷

- (7) a. ?_[PP John-to Bill-kara] otagai-no hahaoya-ga *t* hon-o karita.
 J.-and B.-from each other-GEN mother-NOM book-ACC borrowed
 'From John and Bill, each other's mothers borrowed books.'
- b. ?_[PP John-to Bill-nituite] otagai-no hahaoya-ga Mary-ni *t* tazuneta.
 J.-and B.-about each other-GEN mother-NOM M.-DAT asked
 'About John and Bill, each other's mothers asked Mary.'

Since there is no reason to suppose that a PP checks Case on a functional head, it would appear that A-scrambling is not driven by Case checking. Takano concludes that scrambling is an optional, non-feature-checking movement operation. However, such a proposal fails to account for the evidence, presented below, that scrambling obeys locality. I conclude that object scrambling is indeed forced by a feature-checking requirement on T. However, I propose that the feature to be checked is not Case, but rather a scrambling feature, *Scr*, which attracts a categorial feature of DP or PP—perhaps a feature shared by both categories, such as the [-V] feature of Chomsky (1981). The apparent optionality of scrambling arises from the fact that T can be inserted into the derivation either with or without *Scr*. When *Scr* is present, scrambling is obligatory; when it is absent, scrambling is impossible. In this respect *Scr* differs from EPP, which is always obligatory in the context where it appears.

As we have seen, once the subject itself is in a specifier of T, it no longer blocks attraction of a lower element to check a feature on T. Of course, this means that the subject itself does not check both *Scr* and EPP. As mentioned in Chapter 1, I propose that each attracting feature that require Merge must be checked by a separate instance of Merge. Thus the Merge requirement of EPP and the Merge requirement of *Scr* must be satisfied by

⁷ The exact position of the trace in these examples is irrelevant for our purposes, though relevant for Takano. I have reproduced his examples here verbatim.

separate Merge operations. First the subject merges to check EPP; then, since a head cannot attract the features of an element already in its checking domain, a lower argument is attracted to check the Scr feature of T. The order of feature-checking is simply stipulated: EPP first, then Scr.

In the remainder of this section, I first consider evidence that A-scrambling in Japanese involves movement into multiple specifiers of a single head. I present two kinds of evidence for this view. First, Kuroda (1988) argues that A-scrambling over the subject exploits the same basic mechanism as the “multiple subject” construction in Japanese, in which two arguments appear in specifiers of the head with nominative Case. Secondly, Miyagawa (1997) points out an interaction between the two specifiers: object scrambling is possible only when the subject is nominative or triggers honorification. This interaction suggests that T is directly involved in A-scrambling.

Having argued that scrambling involves movement into a multiple-specifier configuration, I then argue that A-scrambling obeys locality. Richards (1997b) notes that A-scrambling in Japanese falls under a broader generalization regarding multiple specifiers—namely, that they obey featural cyclicity, or “tucking in.” That is, the most local element is attracted first; if another element is also attracted, it moves into a lower specifier than the first. We will adopt a finer-grained version of Richards’ proposal, whereby tucking in applies only to elements checking the same type of feature on a given head. Given this account, we will see that scrambled arguments do obey locality.

1.1 Movement into Multiple Specifiers

To begin, let us consider the evidence for A-scrambling in Japanese. In Japanese, as in Hindi and German, an object can scramble over the subject (8). Various tests indicate that this so-called “IP-adjunction scrambling” can be A-movement (Saito 1992). For example, scrambling can repair a weak crossover violation. An unscrambled object wh-word cannot bind a pronominal variable embedded in the subject, as shown in (8a). However, if the

object scrambles over the subject, the sentence is considerably improved (8b). The improvement is predicted if the object scrambles to an A-position. If it scrambled to an A-bar position, the sentence should still be a weak crossover violation.⁸

- (8) a. ?* Soitu-no hahaoya-ga dare-o aisiteiru no?
 the guy-GEN mother-NOM who-ACC love Q
 'His_i mother loves who_i?'
 b. ? Dare-o soitu-no hahaoya-ga *t* aisiteiru no?
 who-ACC the guy-GEN mother-NOM love Q
 'Who_i his_i mother loves?'

Further evidence for A-scrambling in Japanese comes from restrictions on scrambling idiom chunks. Idiom chunks in Japanese can only scramble to a position within their own clause, as illustrated in (9) (Miyagawa 1997). If the object scrambles to a position above the subject, the idiomatic interpretation is fine, as in (9a). If an object undergoes long-distance scrambling out of a finite clause, then the idiomatic interpretation is impossible. This contrast makes sense if we assume that idiom chunks can only undergo A-scrambling. Note that the contrast in these examples parallels the contrast in the acceptability of binding under local and long-distance scrambling in Hindi ((3-4) above).

- (9) a. Te-o John-ga hoteru-gyoo-ni *t* nobasita.
 hand-ACC J.-NOM hotel-business-DAT extended
 'John became involved in the hotel business.'
 (*lit.* 'John extended his hand to the hotel business.')
- b. ??? Te-o Mary-ga [John-ga hoteru-gyoo-ni *t* nobasita] to hookokusita.
 hand-ACC M.-NOM J.-NOM hotel-business-DAT extended that reported
 'Mary reported that John became involved in the hotel business.'

Like Hindi, Japanese also allows A-bar scrambling to a position above the subject (Kuno 1973, Saito 1989). For example, (10) shows A-bar scrambled objects containing

⁸ As Yoshimura notes, long-distance scrambling in Japanese also repairs weak crossover violations, unlike long-distance movement in Hindi. This seems to suggest that A-movement out of finite clauses is possible in some cases, an option that may be linked to the possibility of well-formed superraising (Ura 1994).

(i) Dare-o soitu-no hahaoya-ga [Hanako-ga *t* aisiteiru]-to omotteru no.
 who-ACC the guy-GEN mother-NOM H.-NOM loves that thinks Q
 'Who_i his_i mother thinks that Hanako loves *t*?'

anaphors bound by the subject. The anaphor *zibun* in (10a) is a “long-distance” anaphor which can be bound either within its clause or across a finite clause boundary, while the anaphor *karezisin* in (10b) is a “local” anaphor, which must be bound within its clause. Both of these anaphors can be bound by the subject, even if they scramble to a higher position. These facts show that the scrambled object is in an A-bar position. The object reconstructs at LF to an A-position below the subject, where it can be bound. These examples are from Saito (1989) and Kazuko Yatsushiro, p.c.⁹

- (10) a. *Zibun-no hahaoya-o John-ga ʔ aisiteiru (koto)*
 self-GEN mother-ACC J.-NOM loves fact
 ‘John loves his mother.’
- b. *Karezisin-no hahaoya-o John-ga ʔ aisiteiru (koto)*
 self-GEN mother-ACC J.-NOM loves fact
 ‘John loves his mother.’

We can ask what makes it possible for one argument to A-scramble over another argument. A promising explanation has been suggested in the literature. Kuroda (1988) proposes that the object can A-scramble past the subject because T allows multiple specifiers in Japanese, a proposal adopted and extended by Ura (1994) and Miyagawa (1997). When the object scrambles over the subject, both the object and the subject move to specifiers of TP. Independent evidence that the subject and the object can occupy multiple specifiers of TP in Japanese comes from the multiple-“subject” construction, discussed by Kuno (1973) and much subsequent work. In this construction, both specifiers of TP are marked with nominative case (11).

- (11) a. *Yama-ga ki-ga kirei desu.*
 mountain-NOM tree-NOM pretty be
 ‘It is the mountains where the trees are beautiful.’ (Kuno 1973)

⁹ Saito uses *koto* ‘the fact that’ in his examples because a matrix sentence without a topic is unnatural. He argues against a reconstruction account of these facts. I assume reconstruction here simply for expository purposes; nothing in particular hinges on this assumption.

- b. Zoo-ga hana-ga nagai.
 elephant-NOM nose-NOM long
 'Elephants' noses are long.' (Ura 1994)

The existence of the multiple-subject construction can be taken as evidence that T in Japanese can have more than just the unique Case and EPP features present on T in English. Examples like (11) seem to involve multiple Case and EPP features; I propose that Japanese T also allows a scrambling feature, Scr, to cooccur with the usual Case and EPP features. Of course, not all languages with A-scrambling appear to allow multiple-subject constructions. The force of the claim is simply that if a language allows multiple subjects, it will allow A-scrambling.

Miyagawa (1997) provides additional evidence that A-scrambling involves movement of the object into a second specifier of the head whose Case feature the subject checks, in our terms T. Specifically, he notes that there is an interaction between the morphological case and agreement associated with the subject, and the possibility of A-scrambling the object. In relative clauses and complex DPs, Japanese allows either a nominative or genitive subject. An accusative object is possible in either case.¹⁰ However, the object can A-scramble over the subject only if the subject is nominative. Miyagawa gives two types of examples to illustrate this effect. First, he shows that an idiom chunk can scramble above a nominative subject, but not above a genitive subject. As we saw above, idiom chunks can only undergo A-scrambling, which is clause-bound, so this distribution indicates a relationship between A-scrambling and the m-case of the subject. (13a) shows that unscrambled idiom chunks are possible with a nominative or genitive subject. A-scrambling the idiom chunk over the subject is grammatical if the subject is nominative (12b), but not if it is genitive (12c).

¹⁰ Miyagawa notes that there is variation in these judgements, with some speakers finding an accusative object marginal with a genitive subject (cf. Harada 1971, Watanabe 1994). Crucially, however, Miyagawa reports that both these speakers and those who find the genitive-accusative combination acceptable agree with the contrast between object A-scrambling with a genitive subject and with a nominative subject.

- (12) a. [Tanaka-**ga**/no hoteru-gyoo-ni te-o nobasita] uwasa
 T.-NOM/GEN hotel-business-DAT hand-ACC extended rumour
 ‘the rumour that Tanaka became involved in the hotel business’
- b. [te-o Tanaka-**ga** hoteru-gyoo-ni t nobasita] uwasa
 hand-ACC T.-NOM hotel-business-DAT extended rumour
 ‘the rumour that Tanaka became involved in the hotel business’
- c. * [te-o Tanaka-**no** hoteru-gyoo-ni t nobasita] uwasa
 hand-ACC T.-GEN hotel-business-DAT extended rumour
 ‘the rumour that Tanaka became involved in the hotel business’

More accurately, as Miyagawa points out, an object can A-scramble over a genitive subject only if the a verb is in the honorific form (13). The honorific form is used in Japanese if the subject is understood to be of higher social rank than the speaker (Harada 1976).

- (13) ? [te-o Tanaka-kyoozyu-**no** hoteru-gyoo-ni t o-nobasi-**ni natta**] uwasa
 hand-ACC Prof. T.-GEN hotel-business-DAT extended.HON rumour
 ‘the rumour that Tanaka became involved in the hotel business’

Subject-honorification is plausibly associated with T as a type of subject agreement. We can suppose that, when subject honorification does not arise, genitive subjects are associated with the “default” agreement that usually goes with quirky subjects. Although nominative subjects in Japanese trigger no special agreement on the verb, cross-linguistically nominative subjects are generally associated with verb agreement. Toribio (1993) argues that both nominative case and subject honorification indicate specifier-head agreement with the subject. Thus we can say that object scrambling is impossible when T has default agreement.

The connection between A-scrambling and m-case/agreement can also be observed from binding possibilities. As we have seen, an object can bind into a subject only if it first scrambles into a higher A-position. A scrambled object can bind into a nominative subject (14a), but not into a genitive one (14b), unless it triggers honorification (14c). Again, these facts show that default T is not consistent with A-scrambling.

- (14) a. $\left[\left[\text{karera-o} \right] \text{otagai-no sensei-ga} \right]_t \text{ kiratteiru} \text{ riyuu}$
 them-ACC each other-GEN teacher-NOM hate reason
 ‘the reason that each other_i’s teachers hate them_i’
- b. ???/* $\left[\left[\text{karera-o} \right] \text{otagai-no sensei-no} \right]_t \text{ kiratteiru} \text{ riyuu}$
 them-ACC each other-GEN teacher-GEN hate reason
 ‘the reason that each other_i’s teachers hate them_i’
- c. ? $\left[\left[\text{karera-o} \right] \text{otagai-no sensei-no} \right]_t \text{ o-home-ni natta} \text{ riyuu}$
 them-ACC each other-GEN teacher-GEN praised.HON reason
 ‘the reason that each other_i’s teacher’s praised them_i.’

The interaction between the m-case/agreement properties of the subject and the possibility of A-scrambling the object supports the view that the scrambled position of the object is in a specifier of T, where the subject checks Case (and nominative m-case) and triggers subject agreement. This interaction can then be formally expressed in terms of co-occurrence restrictions on the features of T. For example, we can say that Scr cannot co-occur with default agreement on T.¹¹

1.2 A-Scrambling Obeys Locality

I have presented one approach to reconciling A-scrambling with locality—namely, by proposing that A-scrambling involves movement of one argument into the checking domain occupied by a higher argument. The literature on Japanese scrambling also suggests another approach. Saito (1989) maintains that Japanese scrambling is optional and semantically vacuous. In keeping with this view, Takano (1997) proposes that scrambling is free adjunction, rather than movement driven by features of an attracting head. Since locality is a condition on feature-attraction, it plays no role where no feature-attraction is involved. Under the adjunction hypothesis, scrambling need not obey locality, so there is

¹¹ Of course, the correlation between A-scrambling and subject m-case/agreement makes even more sense under Miyagawa’s proposal that A-scrambling is for Case-checking. However, I do not adopt this proposal, for the reasons mentioned above (cf. (7)).

no reason why the subject should block A-scrambling of an object. However, a problem for this type of answer is raised by Richards (1997b). Richards demonstrates that A-scrambling does obey locality. Specifically, he provides evidence that the lower object of a double object construction cannot A-scramble past the higher one to a position above the subject, without leapfrogging through the checking domain occupied by the higher object.

The central point of Richards' discussion is that if two arguments scramble over the subject, the second scrambled argument tucks in under the first. An example is shown in (16). The idiomatic interpretation of the verb phrase is available only when the indirect object c-commands the direct object, as in (15a). Under the idiomatic interpretation, if only one of the objects scrambles, it must be the higher one, as in (15b). If the lower one also scrambles, it tucks in under the higher one, as shown in (15c).

- (15) a. Taroo-ga hi-ni abura-o sosoida.
 T.-NOM fire-DAT oil-ACC poured
 'Taroo made things worse.'
- b. Hi-ni Taroo-ga *t* abura-o sosoida.
 fire-DAT T.-NOM oil-ACC poured
- c. Hi-ni abura-o Taroo-ga *t* *t* sosoida.
 fire-DAT oil-ACC T.-NOM poured

Under Attract F, Richards points out, cyclicity is reduced to the requirement that a strong feature on a given head must be checked immediately upon merging that head in the derivation. According to the revisions of Chomsky (1998), adopted here, all features of a head must be checked immediately upon merging that head—including features satisfied by bare Attract. By this view of cyclicity, movement need not always obey the extension condition of Chomsky (1993), where the moved element is merged with the root node of the structure. Provided that overt movement is always into the checking domain of the highest head, a second attracted element can move into a lower specifier of this head than the first attracted element. The examples in (16) show tucking in for multiple *wh*-movement in Bulgarian (Rudin 1988). Richards presents a number of other such cases, including

other cases of multiple *wh*-movement, multiple object shift in Germanic, and multiple A-scrambling.

- (16) a. $\text{Koj kogo vi\zeta da } t [t]?$
 who whom sees
 'Who sees whom?'
 b. * $\text{Kogo koj vi\zeta da } t [t]?$
 whom who sees

Richards proposes that tucking in is always observed when two elements move into specifiers of the same head. On the other hand, in the derivation I proposed in section 1.1, an A-scrambled object does not tuck in under the subject. In such a case, I claimed, the subject moves first, then the scrambled object moves to a higher specifier. Note, however, that the two specifiers of spec-TP check different features; the subject checks Case and EPP features, while the scrambled arguments checks Scr. By contrast, Richards concentrates on cases where both elements check the same feature. We can suppose that tucking in arises whenever two elements check the same type of feature on a given head. As we saw in (15), if a second Scr feature appears on T, the second scrambled object tucks in between the subject and the first scrambled object, in a third specifier of T (17). We obtain the right order if we suppose that specifiers checking features of different types do not tuck in, while those that check features of the same type do tuck in. Of course, (17) is a simplification; I will give the full derivation for (15c) below.

(17)

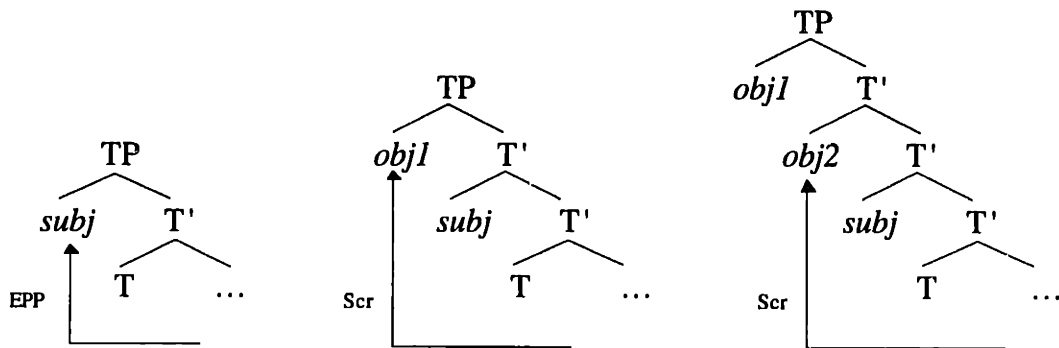

As noted briefly in Chapter 1, restrictions on tucking in were already necessary to account for object-subject order in Icelandic transitive expletive constructions. There we saw that an

object checking Case in spec- ν P moves to a higher specifier than the base position of the external argument, which checks a theta-feature in spec- ν P.

- (18) [_{CP} Það lásu [_{TP} *t*] [_{ν P} [þessar bækur] aldrei neinir stúdentar [_{ν P} *t*] í fyrra]]].
 there read these books never any students last year
 ‘No students ever read these books last year.’

Assuming that Merge precedes Move, the external argument merges in spec- ν P before the object moves there; thus, tucking in is not observed when the object moves to a higher specifier. This observation can be captured under the generalization that tucking in is observed only in checking the same type of feature.

In the previous section, I argued that A-scrambling involves movement into the checking domain occupied by a higher argument. If Richards is correct, then we can assume that A-scrambling of multiple objects obeys tucking in. Tucking-in facts can then be taken as evidence that A-scrambling obeys locality. Since an A-scrambled argument that originates lower tucks in under an A-scrambled argument that originates higher, as shown in (17), we can conclude that the higher argument moves first, in accordance with locality. In the next sections, I will argue that this is indeed the case.

1.2.1 Advancing of idiom chunks

Recall that idiom chunks can undergo only A-scrambling, not A-bar scrambling. Now consider the order of the two objects before scrambling occurs. In general, Japanese allows either the IO-DO order or the DO-IO order, as I will discuss more fully below. However, on the idiomatic interpretation of the double object construction in (19), the indirect object must be higher than the direct object.¹²

- (19) a. Taroo-ga hi-ni abura-o sosoida.
 T.-NOM fire-DAT oil-ACC poured
 ‘Taroo made things worse.’

¹² The starred examples are fine on the non-idiomatic reading (Kazuko Yatsushiro, p.c.). I assume that in these cases an alternative derivation is available, to be discussed next. A-bar scrambling of non-idiomatic arguments is also possible, making the picture even more complicated.

- b. *Taroo-ga abura-o hi-ni sosoida.
 T.-NOM oil-ACC fire-DAT poured
 'Taroo made things worse.'

We may suppose that movement is blocked in (19b) because the idiomatic interpretation is available only with a DP indirect object. Miyagawa (1997) gives evidence, discussed below, that a direct object can scramble over an indirect object only if the indirect object is a PP. A DP indirect object may allow the idiomatic interpretation in (19a), but it blocks A-scrambling of the direct object.

When only one of the idiomatic objects scrambles, it must be the higher one, namely the indirect object. The order IO-S-DO is possible on the idiomatic interpretation, as in (20a). If the direct object undergoes A-scrambling first, yielding the DO-S-IO order in (20b), the idiomatic interpretation is impossible.

- (20) a. Hi-ni Taroo-ga *t* abura-o sosoida.
 └──────────┘
 fire-DAT T.-NOM oil-ACC poured
 'Taroo made things worse.'
- b. *Abura-o Taroo-ga hi-ni *t* sosoida.
 └──────────┘
 oil-ACC T.-NOM fire-DAT poured
 'Taroo made things worse.'

When both objects A-scramble, the scrambled order is the same as the base order. The higher object scrambles first, as we saw in (20). Then the lower object scrambles to a lower specifier of the same head, yielding the order in (21a). If the lower object moves first, or the second moved object moves to a higher specifier of the same head, the derivation is ill-formed (21b). Thus, both locality and tucking in must be observed.

- (21) a. Hi-ni abura-o Taroo-ga *t* *t* sosoida.
 └──────────┘ └──┘
 fire-DAT oil-ACC T.-NOM poured
 'Taroo made things worse.'
- b. *Abura-o hi-ni Taroo-ga *t* *t* sosoida.
 └──┘ └──────────┘
 oil-ACC fire-DAT T.-NOM poured
 'Taroo made things worse.'

The first steps of attraction in (21a) are shown in (22). The Case feature of R attracts the Case and phi-features of the direct object, then the indirect object checks Case on *v*.

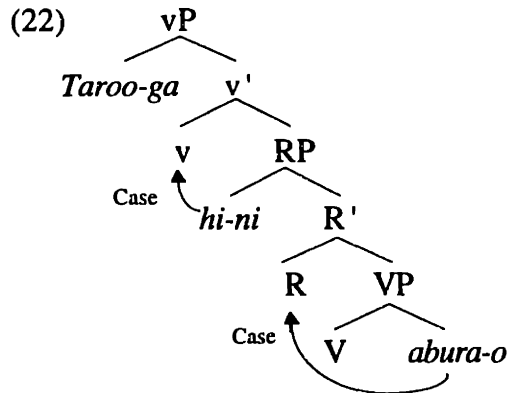

The final stage of movement is attraction to T (23). Since EPP is checked first, the external argument is attracted first to check Case and EPP on T. Locality and Case Identification both prevent either of the lower arguments from checking EPP on T. However, these arguments can be attracted by Scr. I assume that when both objects are scrambled, there are two Scr features on T. The first Scr feature attracts the highest argument, namely the indirect object. The second Scr feature attracts the direct object. Since the two objects check the same type of feature, the second A-scrambled argument tucks in under the first. If only one Scr feature appears on T, only the indirect object can scramble, since it is the closest eligible element.

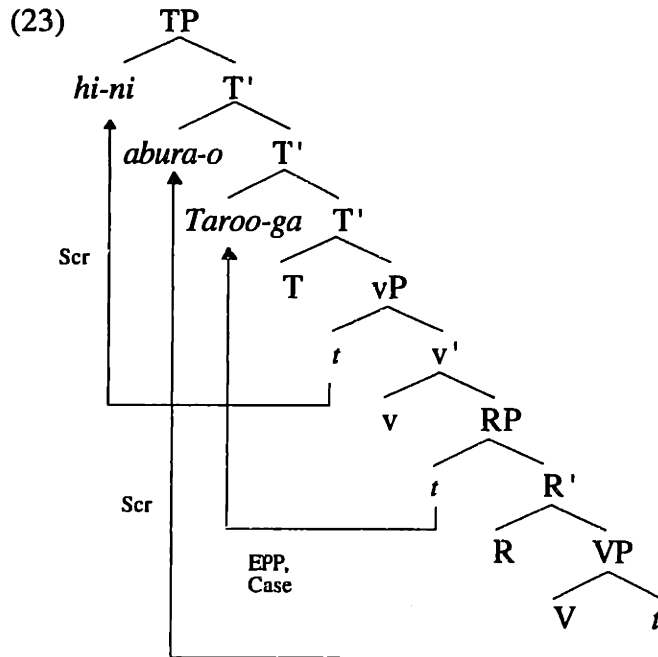

Thus, if the indirect object is higher than the direct object, the direct object cannot A-scramble to spec-TP unless the indirect object moves there first. However, if the direct object can move first into the checking domain occupied by the indirect object, it can leapfrog over the indirect object and A-scramble into spec-TP. In the next section I present evidence for such a derivation.

1.2.2 Leapfrogging of idiom chunks

It has been argued that Japanese allows “short” scrambling, where the direct object scrambles over the indirect object below the syntactic subject position (cf. Saito & Hoji 1983, Hoji 1985, Yatsushiro 1997, among others). For example, Miyagawa (1997) argues that the floated quantifier in (24a) marks the base position of the direct object, showing that movement has taken place.

- (24) John-ga [pen-o] Mary-ni t ni-hon ageta.
 J.-NOM pen-ACC M.-DAT 2-CLS sent
 ‘John gave two pens to Mary.’

Takano (1997) argues that direct object scrambled over a coreferring indirect object can give rise to a Condition C violation (25b). These facts suggest that the direct object can only A-move, not A-bar move, to this position.

- (25) a. ? Mary-ga subete-no gakusei-no sensei-ni soitu-o syookaisita.
 M.-NOM all-GEN student-GEN teacher-DAT he-ACC introduced
 'Mary introduced him to every student's teacher.'
- b. * Mary-ga [soitu-o] subete-no gakusei-no sensei-ni *t* syookaisita.
 M.-NOM he-ACC all-GEN student-GEN teacher-DAT introduced
 'Mary introduced him to every student's teacher.'

I propose that the direct object can A-scramble over the indirect object, an option which allows the direct object to A-scramble to a specifier of T before the indirect object.

In the last section, we saw an idiom in which both objects contribute to the special meaning of the verb phrase. This idiom can be contrasted with idioms like that in (26), in which just the verb and the direct object contribute to the special meaning. In such a case, the direct object can raise to a position above the indirect object, as in (26a). Here the indirect object does not block the direct object from A-scrambling past it, because the direct object raises first into the checking domain occupied by the higher object. Moreover, from this position the direct object can leapfrog over the indirect object to check a Scr feature of T, without violating locality.

- (26) a. John-ga [te-o] hoteru-gyoo-ni *t* nobasita.
 J.-NOM hand-ACC hotel-business-DAT extended
 'John became involved in the hotel business.'
- b. [Te-o] John-ga *t* hoteru-gyoo-ni *t* nobasita.
 hand-ACC J.-NOM hotel-business-DAT extended
 'John became involved in the hotel business.'

The derivation I propose for (26b) is shown in (27). Suppose that in (26) the indirect object is in a PP, merged in the specifier of RP. The direct object checks Case on R, which (optionally) has a Scr feature that attracts the direct object into a second specifier

of RP. The direct object is now sufficiently local to check a Scr feature on T, regardless of whether the indirect object is attracted first.

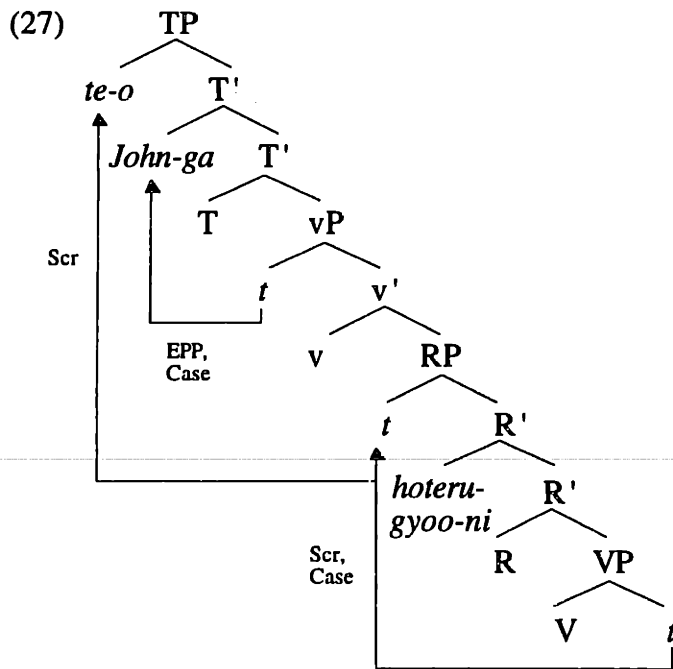

1.2.3 Leapfrogging and Floated Quantifiers

In the previous two sections, I have argued that locality plays a key role in A-scrambling. If a lower direct object cannot leapfrog over a higher indirect object, the lower argument cannot A-scramble to spec-TP until the higher one does. On the other hand, if the direct object can leapfrog over the indirect object, it can A-scramble to spec-TP before the indirect object does.

So far, I have argued for locality in A-scrambling using evidence from idiom chunks, but further support can be found in anaphor binding. As noted above, Miyagawa (1997) argues that a direct object can move overtly over an indirect object. However, he also points out that such movement is possible only with PP indirect objects. He notes that a direct object cannot move over an indirect object associated with a floated numeral quantifier (28a). When the direct object remains in its base position, the sentence is fine, as shown in (28b).

- b. ??Taroo-ga gakusei-o [otagai-no sensei-ni futari] *t* syookaisita.
 T.-NOM student-ACC each other-GEN teacher-DAT two introduced
 'Taro introduced the students to two of each other's teachers.'
- c. Taroo-ga gakusei-o [otagai-no sensei-ni] *t* syookaisita.
 T.-NOM student-ACC each other-GEN teacher-DAT introduced
 'Taro introduced the students to each other's teachers.'

In the terms suggested here, R cannot have a Scr feature unless its specifier is a PP.

However, The presence of the floated quantifier indicates that the dative argument is a DP, so (29b) is out. Since a dative argument without a floated quantifier can be a PP, (29c) is fine.

These cases can be compared with those in (30). In (30a), the direct object can shift over the indirect object and then A-scramble to a position above the subject. In (30b), the indirect object has a floated quantifier, indicating that is a DP. As a result, the lower argument cannot leapfrog over it to an A-position.

- (30) a. [Gakusei-o] [otagai-no adobaizaa-ga] *t* sensei-ni *t* syookaisita.
 student-ACC each other-GEN advisor-NOM teacher-DAT introduced
 'Each other's advisors introduced the students to the teacher.'
- b. * [Gakusei-o] [otagai-no adobaizaa-ga](*t*) sensei-ni futari *t* syookaisita.
 student-ACC each other-GEN advisor-NOM teacher-DAT two introduced
 'The students, each other's advisors introduced to two teachers.'

These examples provide additional evidence that A-scrambling obeys locality. When a lower argument can move into the checking domain occupied by a higher one, it can also leapfrog over this argument to the specifier of a still higher head. Without leapfrogging, however, the lower argument cannot be attracted past the higher one.

1.2.4 Against Skipping

I proposed above that the contrast between movement with and without "tucking in" follow from whether or not the features being checked are of the same type. An alternative view would be that tucking in is *always* observed (Richards 1997b). Under this view, a

scrambled object is in a higher checking domain than the subject, rather than in a specifier of the same checking domain. The subject would then have to be inherently ineligible for attraction to the higher “scrambling” head, so that one or more elements could cross over it without violating locality. However, A-scrambling of a direct over an indirect object provides evidence that A-scrambling involves movement into the checking domain occupied by a higher argument. A direct object can A-scramble to a position c-commanding an indirect object, and can also leapfrog through this position to a higher one; it cannot skip directly over the indirect object to a higher checking domain. Thus “tucking in” is not observed in at least these cases.

Recall that the direct object can A-scramble over a PP indirect object. We can ask whether this is movement into the checking domain occupied by the indirect object, or into a higher checking domain. The proposal I have adopted is that the direct object is attracted into a second specifier of R by an optionally present scrambling feature, yielding the DO-IO order. Since R cannot attract the indirect object already in its specifier, no violation of locality arises if it attracts the direct object. This construction involves multiple specifiers without tucking in. I would argue that again, tucking in is not observed because the arguments bear different relations to the same head. The first specifier, the indirect object, is theta-related to the head. The second specifier checks a Scr feature on R. When tucking in is observed, it arises because multiple specifiers bear the same kind of relation to the head, for example checking multiple *wh*-features, or, as we saw above, multiple scrambling features.

If, instead, we wish to maintain that tucking in always occurs, regardless of the features to be checked, then we must conclude that the DO-IO order involves movement of the direct object to a higher checking domain than the indirect object. If so, the direct object must be moving past the indirect object. What would permit such movement is not at all clear. One possibility that might be entertained is that the lower argument can skip over the higher one because the movement involved is of a kind that fails to attract a PP. However,

this explanation cannot easily be maintained, since a PP can be attracted to a position above the indirect object, as shown in (31b) (Takano 1997).

- (31) a. John-ga Mary-ni [_{PP} Bill-nituite] tazuneta.
 J.-NOM M.-DAT B.-about asked
 'John asked Mary about Bill.'
- b. John-ga [_{PP} Bill-nituite] Mary-ni *t* tazuneta.
 J.-NOM B.-about M.-DAT asked
 'John asked Mary about Bill.'

A second possibility might be that a direct object raises into a higher checking domain by leapfrogging through a specifier of RP. Although this is a possible approach to take, it means that for each instance of scrambling we must postulate *two* scrambling features—one to move the scrambled argument into the checking domain occupied by a higher argument, and one to move it into a higher checking domain. Barring further evidence, such a proposal is unmotivated. Moreover, as noted above, the object-subject order in Icelandic provides further evidence that tucking in is not always observed.

1.3 Summary

In this section I have provided evidence that there is independent evidence that A-scrambling involves movement into the checking domain occupied by a higher argument. If one argument scrambles over another to a higher checking domain, it can only do so by leapfrogging through the same checking domain. The gist of the argument is this: A-scrambling can involve movement of one argument to a position c-commanding another argument. If A-scrambling obeys locality, there are only two ways that the lower argument could undergo such movement: (1) by moving into, or through, the checking domain occupied by the higher argument, or (2) by skipping over a higher argument that is itself ineligible for movement. I began by arguing in Section 1.1 that (1) is the correct view. Arguments in favour of this view included the independent availability of multiple specifiers in the Japanese multiple-subject construction, as well as correlations between

object scrambling and the Case/agreement features of the subject. In Section 1.2 I took a step back and argued that either (1) or (2) is indeed necessary, because A-scrambling does obey locality. Evidence for this claim came from the impossibility of A-scrambling a direct object over an indirect object to spec-TP in cases where the direct object cannot first A-scrambled to spec-RP—specifically, where the indirect object is part of an idiom, or is associated with a floated quantifier. These cases showed that the most local argument must be attracted for A-scrambling before a lower argument can be.

It was necessary to make a slight modification to the theory of tucking in from Richards (1997b). By this modification, tucking in applies only to elements checking the same type of feature on a given head. If the original theory were to be maintained, then A-movement disobeying tucking in would have to involve movement of one argument past another to a higher checking domain. In the final subsection I argued that this account makes the wrong predictions. My argument was based on the observation that a PP can also be attracted over an indirect object. If this movement were to a higher checking domain than the indirect object, we would expect the indirect object itself to be attracted instead. If instead it is movement into the same checking domain, as I maintain, then no locality violation arises.

In Section 2 I will argue for the empirical generalization I have called Lethal Ambiguity. When an argument moves out of a specifier in the same checking domain as another argument, an anaphoric dependency between the two arguments is blocked. This restriction on the distribution of anaphora will be used in Section 3 to identify leapfrogging of a lower argument past a higher one in movement to the subject position. In Section 4 I will argue that Lethal Ambiguity arises whenever a lower argument moves into the checking domain of a higher argument, even if this higher argument is the one that moves to the subject position.

2 Lethal Ambiguity

In the previous section, I argued that A-scrambling involves movement of a lower argument into the checking domain occupied by a higher argument. A-scrambling has consequences for anaphora, as already noted in the literature (Snyder 1992, Miyagawa 1997, Yatsushiro 1997, among others). An A-scrambled argument can bind into the argument it scrambles over, but cannot bind that argument directly. I propose that this restriction falls under the generalization stated in Chapter 1 and called there *Lethal Ambiguity*.

- (32) An anaphoric dependency cannot be established between two specifiers in the same checking domain.

Consider the German examples in (33). A subject can bind an unscrambled object, as shown in (33a). We saw examples above where an object scrambled to a position above the subject can bind into it; specifically, an object quantifier can bind a pronoun embedded in the subject. On the other hand, a scrambled object cannot bind the subject itself, as shown in (33b).

- (33) a. Vermutlich hat der Mann sich selbst (im Spiegel) gesehen.
presumably has the man.NOM himself in-the mirror seen
'Presumably, the man has seen himself (in the mirror).'
- b. * Vermutlich hat [den Mann] sich selbst (im Spiegel) _t gesehen.
presumably has the man.ACC himself in-the mirror seen
'Presumably, himself has seen the man (in the mirror).'

The derivation of this structure is shown in (34). Note that both the anaphoric subject and the scrambled object occupy specifiers of TP. This configuration is sufficient to give rise to *Lethal Ambiguity*; no well-formed anaphoric dependency can be established between the two arguments.

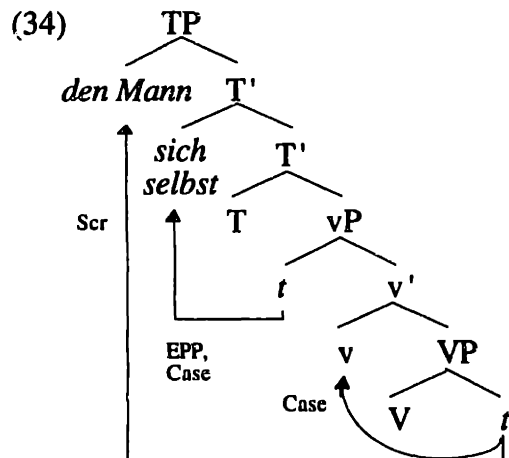

It might be objected that (33b) is ill-formed simply because German lacks nominative anaphors. However, such a counterproposal cannot explain the ill-formedness of parallel examples in other languages, where nominative anaphors are perfectly acceptable. For instance, Japanese has a dative subject construction, associated with experiencer verbs (cf. Shibatani 1977, Perlmutter 1984, Ura 1996, among others). The dative argument is a true syntactic subject: it controls into adjunct clauses, triggers subject honorification, and binds subject-oriented reflexives. It can also bind anaphors without a strict subject-orientation, such as reflexive *karezisin* and reciprocal *otagai*. Since dative subjects occur with nominative objects, these anaphors can be nominative, as shown below.

- (35) a. Taroo-ni karezisin-ga sinpai-da.
 T.-DAT self-NOM worry-be
 'Taro worries himself.'
- b. Taroo-to Hanako-ni otagai-ga sinpai-da.
 T.-and H.-DAT each other-NOM worry-be
 'Taro and Hanako worry each other.'

Another language that allows the object to scramble over the subject is Georgian. Georgian also has nominative anaphors. When the subject is ergative or dative, the object is nominative, and can be anaphoric, as shown in (36). (36a) is a transitive verb in the aorist, with an ergative subject, and (36b) is in the evidential, where the subject is dative.

- (36) a. Vano-m da-irçmun-a tavisı tav-i.
 V.-ERG PREV-convince-AOR self-NOM
 'Vano convinced himself.' (Harris 1981:41)
- b. Gela-s turme da-u-rçmun-eb-ia tavisı tav-i.
 G.-DAT apparently PREV-R-convince-TS-EVID self-NOM
 'Gela apparently (has) convinced himself.' (Harris 1981:125)

In these languages, therefore, there is no ban on nominative anaphors. Nevertheless, a scrambled object cannot bind a nominative subject in either of these languages.

2.1 Japanese

First, consider Japanese. As we have seen, an object that scrambles to a position above the subject can bind a possessive anaphor in the subject.

- (36) a. ?? [Karezisin-no hahaoya]-ga Hiroshi-o waratta.
 self-GEN mother-NOM H.-ACC laughed.PST
 'His_i mother laughed at Hiroshi_i.'
- b. Hiroshi-o [karezisin-no hahaoya]-ga t waratta.
 H.-ACC self-GEN mother-NOM laughed.PST
 'His_i mother laughed at Hiroshi_i.'

On the other hand, the scrambled object cannot bind the subject itself, as shown in (37).

The interactions between binding and scrambling in Japanese parallels the situation in German. In Japanese, however, it is clear that the inability of the scrambled object to bind the subject does not arise because there is no nominative anaphor. The nominative anaphor is well-formed, but nevertheless the derivation crashes (Yatsushiro 1997 and p.c.).¹⁵

- (37) a. Hiroshi-ga karezisin-o waratta.
 H.-NOM self-ACC laugh.PST
 'Hiroshi laughed at himself.'

¹⁵ Yatsushiro (1997) argues that the reflexive *karezisin*, but not the reciprocal *otagai*, is subject to the restrictions on anaphora I am attributing to Lethal Ambiguity. This contrast arises because of the complex structure of the reciprocal (Lebeaux 1983, Heim, Lasnik & May 1991). Nevertheless, Miyagawa (1997) points out that examples like (37b) are also ungrammatical with *otagai*:

- (i) ??? John-to Mary-o otagai-ga t mita.
 J.-and M.-ACC each other-NOM saw
 'John and Mary saw each other.'

- b. * Hiroshi-o karezisin-ga } waratta.
 H.-ACC self-NOM laugh.PST
 ‘Hiroshi laughed at himself.’

The restriction on anaphora also cannot be attributed to a ban on nonsubject binders. Note that *karezisin* can in principle be bound by a nonsubject. For example, we have seen *karezisin* bound by a scrambled object, when it occurs a possessive anaphor embedded in the subject. It can also be bound by a nonsubject as an argument of the verb. In (38a), for example, an indirect object can bind an accusative *karezisin*. When this indirect object scrambles over the subject, it can bind into the subject (38b), but still cannot bind the subject itself (38c). The scrambled argument can in principle bind an argumental *karezisin*; it simply cannot bind an anaphoric subject (examples from Yatsushiro 1997 and p.c.).

- (38) a. Hiroshi-ga (kagami-o tukatte) Osamu-ni karezisin-o miseta.
 H.-NOM mirror-ACC using Osamu-DAT self.-ACC showed
 ‘Hiroshi, showed Osamu, himself_i (using a mirror).’
- b. John-ni karezisin-no hahaoya-ga } Mary-o miseta.
 J.-DAT self-GEN mother-NOM M.-ACC showed
 ‘His_i mother showed John, Mary.’
- c. * John-ni karezisin-ga } Mary-o miseta.
 J.-DAT self-NOM M.-ACC showed
 ‘Himself showed John Mary.’

It has been pointed out (Richards 1997a) that the distribution of anaphors in Japanese suggests that they are in competition: where one anaphor is preferred, it prevents the use of another. It might thus be objected that (38c) is ungrammatical because another anaphor is preferred. In fact, however, no anaphor is possible in this context. The ungrammatical examples in (39) show the scrambled object binding *zibunzisin*, which must be locally bound (39a), and *zibun*, which can be locally or long-distance bound (39b). The ill-formedness of (39b) can be contrasted with the well-formedness of (39c), where *zibun* is long-distance bound by the subject of a higher clause. This example shows that there is

no general ban on subject anaphors; such anaphors simply cannot be bound by a scrambled element.

- (39) a. * Hiroshi-o zibunzisin-ga t waratta.
 H.-ACC self-NOM laugh.PST
 ‘Hiroshi laughed at himself.’
- b. * Hiroshi-o zibun-ga t waratta.
 H.-ACC self-NOM laugh.PST
 ‘Hiroshi laughed at himself.’
- c. Ayumi-wa [zibun-ga utokusii]-to omotteiru.
 A.-TOP self-NOM beautiful that think
 ‘Ayumi thinks that she is beautiful.’

Needless to say, the option of A-bar scrambling the object over the subject does not improve the situation for binding the subject. Since an A-bar scrambled object reconstructs below the subject at LF, it is in no position to bind the subject in any case. The only circumstances under which we expect the object to be able to bind the subject arise when the object scrambles to a higher A-position, where it can at least bind *into* the subject. As we have seen, Japanese does allow A-scrambling past the subject, but the scrambled element cannot bind the subject.

As argued above, an object A-scrambled over the subject in Japanese occupies a specifier of TP, while the subject is also in spec-TP. This multiple-specifier configuration is subject to Lethal Ambiguity, so no anaphoric dependency can be established between the direct object and the subject. On the other hand, nothing prevents the direct object from binding an anaphor embedded within the subject. Since the scrambled direct object c-commands the subject from its position as a higher specifier in the same checking domain, it is in a position to bind the subject or anything embedded within it. Binding the subject would give rise to Lethal Ambiguity, but no problem arises with binding into the subject. Supposing that an A-scrambled object in German also scrambles into a second specifier of TP, the inability of the object to bind the subject also follows from Lethal Ambiguity.

2.2 Georgian

A similar array of facts arises in Georgian. Georgian also allows an object to A-scramble over a subject, as shown in (40). The unscrambled object cannot bind the possessive reflexive *tavis* embedded in the subject. When the object scrambles to the left of the subject, however, binding is acceptable.

- (40) a. ??Tavisi deida nino-s xatav-s.
 self's aunt.NOM N.-DAT draw-PRES
 'Her_i aunt is drawing Nino_j.'
- b. Nino-s tavis deida *t* xatav-s.
 N.-DAT self's aunt.NOM draw-PRES
 'Her_i aunt is drawing Nino_j.'¹⁶

Again, this contrast cannot simply be attributed to linear order. In Georgian, the object can A-bar scramble to a position above the subject. Thus a scrambled object can contain a possessive anaphor bound by the subject, as shown in (41b).

- (41) a. Nino tavis deida-s xatav-s.
 N.NOM self's aunt-DAT draw-PRES
 'Nino_i is drawing her_j aunt.'
- b. Tavis deida-s nino *t* xatav-s.
 self's aunt-DAT N.NOM draw-PRES
 'Nino_i is drawing her_j aunt.'

In its A-bar scrambled position, the possessive anaphor linearly precedes its binder.

However, it is licensed by LF reconstruction to a position below its binder. In (40a), the subject cannot reconstruct to a position below the object, so binding is ill-formed.

¹⁶ On the basis of scope judgements, Nash (1995) argues that the object cannot occupy an A-position above the subject. In (i), for example, although the (nominative) object scrambles over the subject, the only possible reading has narrow scope for the object (i.e. three particular students played all the sonatas). (i) does not allow the wide scope reading (i.e. students can vary with sonatas).

(i) (Am koncertze) [qoveli sonaṭa] samma student-ma *t* virtuozulad ṡeasrul-a.
 this concert-at each sonata.NOM three students-ERG virtuosically execute-AOR
 'At this concert, three students virtuosically executed each sonata.' Nash (1995:258)

This suggests that the object must be in an A-bar position, and obligatorily reconstructs to a position below the subject (*t*). On the other hand, a similar reconstruction of the object in (40b) would lead to ungrammaticality. It is not clear to me at present how these facts can be reconciled, though the definiteness of the subject may be a relevant factor.

As in Japanese, an A-scrambled object in Georgian cannot bind the subject itself. (42a) shows the grammatical binding configuration, with the subject binding the direct object. The anaphoric object can A-bar scramble to a position above its binder, as in (42b). In the usual case, it can also undergo A-scrambling, but if the subject is an anaphor the derivation crashes (42c). (42c) is also ungrammatical if the object A-bar scrambles to a position above the subject, since it cannot bind the subject from its reconstructed position at LF.

- (42) a. Vano tavis tav-s xatav-s.
 V.NOM self-DAT draw-PRES
 'Vano is drawing himself.'
- b. Tavis tav-s Vano t xatav-s.
 self-DAT V.NOM draw-PRES
 'Vano is drawing himself.'
- c. * Vano-s tavis tav-i t xatav-s.
 V.-DAT self.NOM draw-PRES
 'Himself is drawing Vano.'

Here again, the ill-formedness of (42c) cannot be attributed to the m-case of the anaphor, since Georgian has nominative anaphors. Rather, it is the structural configuration of the anaphoric subject and the scrambled object that gives rise to ungrammaticality.

Constructions with a dative subject in Georgian also demonstrate the irrelevance of m-case. The facts described above are exactly parallel to those in a dative subject construction. An unscrambled object cannot bind into a dative subject (43a). If the object scrambles to a position above the subject, it can bind into the subject, as shown in (43b). On the other hand, the object cannot bind the subject itself, even from a scrambled position.

- (43) a. ??Tavis mama-s vano da-u-rcmun-eb-ia.
 self's father-DAT vano.NOM PREV-R-convince-EVID
 'His_i father has convinced Vano_i.'
- b. Vano tavis mama-s t da-u-rcmun-eb-ia.
 vano.NOM self's father-DAT PREV-R-convince-EVID
 'His_i father has convinced Vano_i.'

- c. * Vano tavis tav-ε t da-u-rçmun-eb-ia.
└──────────┘
 vano.NOM self-DAT PREV-R-convince-EVID
 ‘Himself has convinced Vano.’

There is certainly no ban on dative anaphors. A dative indirect object can be bound by a nominative or ergative subject with no problem (44). The problem in (43c) is that the scrambled object cannot raise past the subject position without giving rise to Lethal Ambiguity.

- (44) a. Vano e-laparaḳeb-a tavis tav-s.
 V.NOM R-talk-PRES self-DAT
 ‘Vano is talking to himself.’
- b. Nino-m tavis tav-s simartle a-u-giar-a.
 N.ERG self-DAT truth PREV-R-reveal-AOR
 ‘Nino revealed the truth to herself.’

As with Japanese *karezisin*, a nonsubject can in principle bind the anaphor *tavis tav*, at least for some speakers.¹⁷ (45) shows the indirect object *gela* binding an anaphoric direct object. (45a) is in the aorist, where the m-case marking on direct and indirect objects is morphologically distinct. This example makes it clear that it is the indirect object binding the nominative direct object, and not the other way around. (45b) shows that the same binding relations also hold in the present.

- (45) a. Nino-m gela-s tavis tav-i a-nax-a sarḳeši.
 N-ERG G-DAT self-NOM R-show-AOR mirror-in
 ‘Nino_i showed Gela_j himself_j / ?herself_i in the mirror.’
- b. Nino gela-s tavis tav-s a-čveneb-s sarḳeši.
 N.NOM G-DAT self-ACC R-show-PRES mirror-in
 ‘Nino_i shows Gela_j himself_j / ?herself_i in the mirror.’

When the indirect object scrambles to a position above the subject, it can bind into the subject, as shown in (46a). Again, however, it cannot bind the subject itself (46b). The ill-formedness of binding in (46b) cannot be attributed to some inherent property of the

¹⁷ For Harris’ (1981) consultants, *tavis tav* is subject-oriented. However, my consultant (Léa Nash) allows an indirect object to bind a direct object *tavis tav*.

binder, since the same argument can bind an anaphor as long as the anaphor is not the subject.

- (46) a. Gela-s tavis_i deda _t nino-s ačveneb-s.
 G.-DAT self's mother.NOM N.-ACC R-show-PRES
 'His_i mother showed Gela, Nino.'
- b. *Gela-s tavis_i tav-i _t nino-s ačveneb-s.
 G.-DAT self-NOM N.-ACC show-PRES
 'Himself_i showed Gela, Nino.'

The indirect object can itself be bound by the subject, whether it remains below the subject (47a) or scrambles to an A-bar position above it (47b). These examples demonstrate that there is no problem with an anaphoric dependency between the subject and the indirect object.

- (47) a. Gela tavis tav-s nino-s ačveneb-s.
 G.NOM self-DAT N.-ACC show-PRES
 'Gela_i showed himself_i, Nino.'
- b. Tavis tav-s Gela _t nino-s ačveneb-s.
 self-DAT G.NOM N.-ACC show-PRES
 'Gela_i showed himself_i, Nino.'

Again, we can attribute the ill-formedness of binding in (46b) to Lethal Ambiguity. If, as in Japanese, the object scrambles into the checking domain occupied by the subject, it cannot bind the subject even though it is in a c-commanding position. On the other hand, it can bind an anaphor embedded within the subject, as this relation does not involve a direct anaphoric dependency between the subject and the object.

2.3 Hindi

Since we began our discussion of A-scrambling with Hindi, something should be said about whether Hindi allows an object to bind an anaphoric subject. As it turns out, the facts in Hindi are more difficult to elicit than in Georgian and Japanese, because the anaphor

apne is subject-oriented for many speakers. Mahajan (1990) reports that an A-scrambled object can bind a possessive anaphor in the subject (48).

- (48) a. */?/?/? Apne baccon-ne mohan-ko ghar se nikaal diyaa.
 self's children-ERG M.-ACC house from throw give-PERF
 'Mohan's children threw him out of the house.'
- b. ? mohan-ko apne baccon-ne ghar se nikaal diyaa.
 M.-ACC self's children-ERG house from throw give-PERF
 'Mohan's children threw him out of the house.'

Mahajan notes that (48b) is "slightly odd" because of a preference for using a pronoun instead of *apne*. My consultant (Rajesh Bhatt) finds this example quite marginal, but agrees that there is a contrast between (48a) and (48b). (48b) can also be compared with (49b), which has an ergative anaphor bound by a scrambled nominative subject. My consultant reports this example to be completely unacceptable.¹⁸ Assuming that the object again scrambles to a specifier of TP, the contrast between (48b) and (49b) can be attributed to Lethal Ambiguity. This constraint creates no problem for binding a possessive anaphor within the subject, provided that the speaker allows the anaphor to be bound by a nonsubject in the first place.

- (49) a. Raam-ne apne-aap-ko maaraa.
 R.-ERG self-ACC beat-PERF
 'Raam beat himself.'
- b. *Raam-ko apne-aap-ne *t* maaraa.
 R.-ACC self-ERG beat-PERF
 'Raam beat himself.'

¹⁸ Jones (1993) notes that judgements differ for reflexive and reciprocal anaphors in Hindi. His consultants, who do not allow a scrambled object to bind the reflexive possessor in the subject (48b), reportedly do allow it to bind a reciprocal subject (i). My own consultant also does not treat reciprocals as subject-oriented, but finds (i) even more marginal than (48b). He does, however, find it slightly better than (ii), where the object is not scrambled.

- (i) Jon aur meri-ko ek dusree-ne *t* dekhaa.
 J. and M.-OBJ each other.ERG see.PERF
 'John and Mary saw each other.'
- (ii) *Ek dusree-ne jon aur meri-ko dekhaa.
 each other.ERG J. and M.-OBJ see.PERF

Since the judgements seem to vary so widely, I will leave this issue aside. Thanks to Rajesh Bhatt for judgements and for helpful discussion of these issues.

2.4 Scrambling into spec-RP

We have seen the effects of Lethal Ambiguity in a range of cases where an object A-scrambles over the subject. Such effects also arise when a lower object A-scrambles over a higher object. Given the derivation proposed in section 1, Lethal Ambiguity is expected in these cases. Movement involves attraction of the lower object into a specifier of RP, in the same checking domain occupied by the higher object. As predicted, a direct object A-moved past the indirect object cannot bind it, even though, as we saw above, Japanese *karezisin* does not have to be bound by a subject. Compare the derivations in (50), where the direct object A-scrambles to spec-RP. From this position it can bind into the indirect object, as in (50a), but cannot bind the indirect object itself (50b).¹⁹ (50b) is marginally grammatical with the indirect object bound by the subject, but in such a case the subject-oriented anaphor *zibunzisin* is much preferred (Takako Aikawa, p.c).

- (50) a. Hiroshi-ga Osamu-o karezisin-no hahaoya-ni } miseta.
 H.-NOM O.-ACC self-GEN mother-DAT showed
 ‘Hiroshi showed Osamu, his, mother.’
- b. Hiroshi-ga (kagami-o tukatte) Osamu-o karezisin-ni } miseta.
 H.-NOM mirror-ACC using O.-ACC self-DAT showed
 ‘Hiroshi, showed Osamu, to himself_{7,0/7,7} (using a mirror).’

We saw above that when the direct object of a double object construction A-scrambles over the subject, it must first leapfrog through a specifier of R, in the same checking domain as the indirect object. As a result, we again expect that no anaphoric dependency can be established between the two objects—and indeed, even after moving to the specifier of a higher head, the direct object cannot bind the indirect object. Again, the derivation in (51b) is permissible to the extent that the subject can be taken to bind the indirect object.

¹⁹ Miyagawa (1997) notes that Chain Condition/Lethal Ambiguity effects do not arise with the reciprocal *otagai* in examples like (50b). Based on this observation, he argues that the direct object can be base-generated above the indirect object. However, Yatsushiro (1997) argues that *otagai* is not subject to disjoint reference effects (cf. footnote 13).

- (51) a. Osamu-o Hiroshi-ga t karezisin-no hahaoya-ni t miseta.
 O.-ACC H.-NOM self-GEN mother-DAT showed
 'Hiroshi showed Osamu, to his, mother.'
- b. Osamu-o Hiroshi-ga (kagami-o tukatte) t karezisin-ni t miseta.
 O.-ACC H.-NOM mirror-ACC using self-DAT showed
 'Hiroshi, showed Osamu, to himself_i (using a mirror).'

Lethal Ambiguity effects can also be seen when a direct object A-scrambles over an indirect object in Georgian. A dative indirect object in Georgian appears to be generated above the direct object. From this position, the indirect object can bind either a possessive anaphor embedded in the direct object (52a) or the direct object itself (52b).²⁰ The possessive anaphor can also be bound by the subject, as shown.

- (52) a. Nino-m gela-s tavisideida a-nax-a sarkeši.
 N.-ERG G.-DAT self's aunt-NOM R-show-AOR mirror.in
 'Nino, showed Gela, his, / her, aunt.'
- b. Nino-m gela-s tavisitav-i a-naxa sarkeši.
 N-ERG G.-DAT self-NOM R-show-AOR mirror-in
 'Nino, showed Gela, himself, / ?herself, in the mirror.'

The direct object can A-scramble past the indirect object in Georgian, as shown in (53). The A-moved object can bind into the indirect object (53a), but cannot bind it directly (53b).²¹ The same is true if the direct object scrambles past the subject as well as the indirect object (53c). As in Japanese, A-moving the direct object over an indirect object anaphor is grammatical only when the anaphor is bound by the subject.²²

²⁰ In the evidential, where the subject is in the dative case, the indirect object cannot also be dative; it must appear in a postpositional phrase marked with *-tvis*. This also happens in a passive with an indirect object. Usually, the *-tvis* phrase has only a benefactive interpretation, but in the evidential and passive, it has the wider range of interpretations open to the dative indirect object. Nevertheless, the *-tvis* phrase cannot bind a direct object (Léa Nash, p.c.):

(i) Nino-s gelas-tvis u-čveneb-ia tavisitav-i.
 N.-DAT G.-for R-show-EVID self-NOM
 'Nino showed Gela herself_i / *himself_j.'

²¹ Examples of this kind are also given by Harris (1981). However, Harris reports that her consultants never accept examples like (53b), with a nonsubject binding *tavisitav* (see fn. 15).

²² The fact that the subject can bind the anaphor in these examples indicates that an anaphor need not be coindexed with an argument in another specifier of the same head, contrary to what is proposed by McGinnis (1997). In this earlier work, I attempted to unify restrictions on the distribution of anaphoric and ARB clitics under Lethal Ambiguity. Since the restrictions on ARB arguments appear to be semantic (not
 (cont'd...)

- (53) a. Nino-m bavšv-i [tav-is deda-s] † a-nax-a.
 N.-ERG child-NOM self's mother-DAT R-show-AOR
 'Nino_i showed the child_j to its_j / ?her_i mother.'
- b. Nino-m gela tavis tav-s † a-nax-a sarkeši.
 N.-ERG G.NOM self-DAT R-show-AOR mirror.in
 'Nino_i showed Gela_j to herself_j / *himself_j in the mirror.'
- c. Gela nino-m tavis tav-s † a-nax-a sarkeši.
 G.NOM N.-ERG self-DAT R-show-AOR mirror.in
 'Nino_i showed Gela_j to herself_j / *himself_j in the mirror.'

To sum up, A-scrambling one argument over another gives rise to Lethal Ambiguity effects in a range of different languages. The moved argument can bind an anaphor embedded within an argument it moves over, but cannot bind the argument itself. The existence of nominative anaphors in Japanese and Georgian shows that the problem with these constructions is not simply that there is no appropriate m-case for a subject anaphor. Moreover, examples from Georgian and Japanese indicate that A-scrambling a direct object over an indirect object anaphor is just as ill-formed as A-scrambling an object over a subject anaphor. We have seen evidence from Japanese that A-scrambling a lower argument over a higher one involves movement into a multiple-specifier configuration in spec-RP or spec-TP. Leapfrogging through a multiple-specifier configuration permits a lower argument to move past a higher one without violating locality. The proposal here is that it is the arguments in this specific configuration that are subject to Lethal Ambiguity.

3 Leapfrogging to the Subject Position

Having argued that movement into multiple specifiers creates the environment for Lethal Ambiguity, I now return to the main thread of my account. To recap, we saw evidence in the last chapter that the argument generated highest can advance to the subject position,

(...cont'd.)

restricted to morphological clitics), it is probably misleading to unite them with restrictions on anaphoric clitics.

provided that it has an unchecked Case feature. I argued that, where advancing is obligatory, locality and Case Identification jointly ensure attraction of this highest argument to the subject position. By locality, a DP in a lower minimal domain cannot be attracted past the highest DP (54a); by Case Identification, an argument that has checked Case cannot pied-pipe to check EPP (54b).

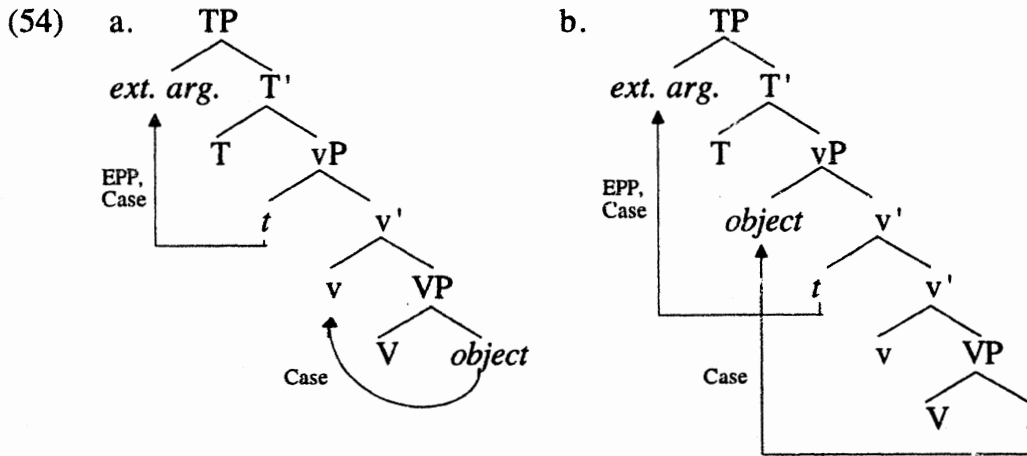

We also saw examples in which the highest argument checks its Case feature by Merge with its theta-assigning head (55). This argument then cannot itself pied-pipe to spec-TP, but it nevertheless blocks T from attracting a lower argument. These cases provide a strong argument that locality plays a role in A-movement.

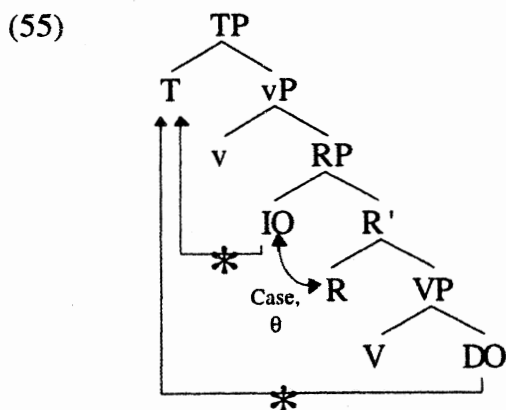

If the Lethal Ambiguity generalization is stated correctly, then the leapfrogging effects discussed in the present chapter also provide evidence for locality in A-movement. In A-scrambling, one argument can only be attracted past another by first leapfrogging through the same checking domain. Unless the lower argument moves into the same

checking domain as the higher one, the higher one must be attracted instead. On the other hand, if locality played no role in A-movement, there would be no reason why the lower argument could not be attracted directly to T. In other words, we would not expect a contrast between leapfrogging, which gives rise to Lethal Ambiguity, and skipping, which does not, as we will see in the next chapter. Thus the effects of Lethal Ambiguity in leapfrogging provide an indirect argument for locality in A-movement.

My account of leapfrogging to the subject position involves a number of proposals, outlined in Chapter 1. First, assuming Case Identification, an argument cannot move to the subject position if it already has a checked Case feature. Thus, in order to leapfrog to the subject position, a lower argument must move into the checking domain of the highest argument without checking Case. I proposed that heads other than T can have an EPP feature for a lower argument to check. Specifically, when the Case feature on R is suppressed in a passive, I proposed that it is replaced by an EPP feature. This proposal implies another, namely that in some languages the Case feature in a passive ditransitive is suppressed on R, not on *v*. Once the lower object is in a specifier of RP, it is sufficiently local to be attracted to the subject position.

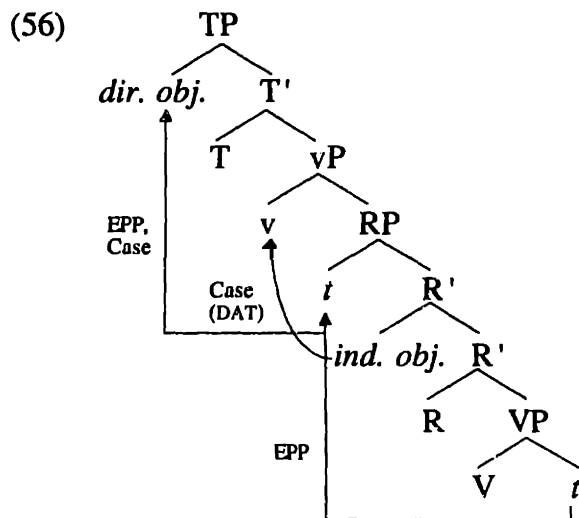

In this chapter I will discuss three cases of this kind. Two involve obligatory leapfrogging, which I propose arises because the indirect object is inherently specified by

its theta-assigner as having dative morphological case. Assuming that dative m-case can be checked on ν , and not on T, the indirect object must check Case and m-case on ν for the derivation to converge. If the indirect object moves to spec- ν P, however, it will again block T from attracting the lower direct object in spec-RP. I propose that a successful derivation can be achieved in two ways. One is for the indirect object to check Case by Attract, as shown in (56). It then remains in spec-RP, allowing the other specifier of RP, the direct object, to move to spec-TP. Another possibility is for a clitic indirect object to check Case in spec- ν P, and then cliticize to T. Once adjoined to T, the clitic does not block attraction of the direct object in spec-RP. Another case to be discussed involves languages with “symmetric” passives, which allow either the indirect or the direct object to raise to the subject position.

In the rest of this section, I will provide evidence from a range of different languages for leapfrogging through a specifier of a higher head. First we will consider Albanian, which allows only the leapfrogging derivation. The analysis given there is also predicted to hold for the parallel derivation in languages with “symmetric” DP passives, in which either DP can raise to the subject position. We will then return to the “superraising” cases identified in Chapter 2, in which the highest argument checks inherent Case. As we will see, in some languages these derivations can be saved if this argument is a clitic or is clitic-doubled. I will propose that in these cases the highest argument is generated with structural dative Case, allowing the leapfrogging derivation. In other languages, even a clitic or clitic-doubled higher argument blocks a lower argument from raising; there we will suppose that there is no alternation between inherent and structural Case.

3.1 Long passives

In a number of languages, as we saw in Chapter 2, only the higher argument of a double-object passive can raise to the subject position, yielding a short passive. In Albanian, only the long passive is possible, with the lower argument raising past the higher one. Lethal

Ambiguity effects provide evidence that long passives in Albanian are possible only because the lower object leapfrogs to the subject position through the checking domain occupied by the higher object. The same analysis can be carried over to other languages.

3.1.1 Obligatory long passives

Quantifier-pronoun binding in Albanian indicates that the indirect object c-commands the direct object. An indirect object quantifier can bind a pronoun in the direct object, as in (57a), but not vice versa (57b). The same is true regardless of word order, as noted in previous chapters.

- (57) a. Agimi ia dha secilit djalë pagën e tij.
 A.NOM CL give each boy.DAT pay.ACC his
 ‘Agim gave to each boy his pay.’
- b. *Agimi ia ktheu secilin liber autorit të tij.
 A.NOM CL return each book.ACC author.DAT its
 ‘Agim returned to its author each book.’

In Albanian, the higher object cannot advance to the subject position of a passive. Word order in Albanian is fairly free, but the quantifier-pronoun binding relations in (57) show that the direct object, rather than the indirect object, raises to the subject position of a passive. The binding possibilities for the active are reversed in the passive: once in the subject position, a direct object quantifier can bind a pronoun in the indirect object, but not vice versa (Massey 1992 and p.c.).

- (58) a. Secili libër iu ktheu [RP t autorit të tij [VP t]].
 each book.NOM CL returned.NACT author.DAT its
 ‘Each book was returned to its author.’
- b. *Secilit djalë iu dha [RP t [VP paga i tij]].
 each boy.DAT CL gave.NACT pay.NOM his
 ‘Each boy was given his pay.’

Under the feature-based theory of locality adopted here, the movement in (58a) is possible under one of two conditions. If the indirect object is a PP, the lower object should be able to skip directly over it to the subject position. However, if the indirect object is a DP, the

lower object should not be able to raise past it except by leapfrogging through the same checking domain. In this case, we would expect to see Lethal Ambiguity effects in the passive. This expectation is confirmed, as shown below.

- (59) a. Secili djalë iu tregua [_{RP} *t* babës të tij [_{VP} *t*]].
 each boy.NOM CL show.NACT father his.DAT
 ‘Each boy was shown to his father.’
- b. *Drita iu tregua [_{RP} *t* vetes [_{VP} *t*]] prej artistit.
 Drita.NOM CL show.NACT self.DAT by the.artist
 ‘Drita was shown to herself by the artist.’

In (59a) the direct object leapfrogs past the indirect object to the subject position. No Lethal Ambiguity arises, since no anaphoric dependency holds between the two arguments. If the indirect object is an anaphor, however, the result is uninterpretability. The anaphor must be bound within its clause, but cannot be bound by the only available binder.

It should be noted that there is no general restriction on coreference between the two objects of the Albanian double-object construction. In the active counterpart of (59b), the higher object can bind the lower one, as shown in (60a). The indirect object occupies the higher A-position in the active construction, so it can bind the direct object, but not vice versa. As we saw in Chapter 2, the direct object can scramble to an A-bar position above the indirect object in Albanian, a movement that does not affect binding relations (60b). Although even the scrambled direct object cannot bind the indirect object, there is no problem with the dative anaphor itself, provided that it is bound by an argument in a c-commanding A-position, such as the subject. These judgements hold regardless of word order. Thus the ungrammaticality of (59b) appears to be due to the Lethal Ambiguity effects arising from leapfrogging.

- (60) a. Murati ia tregoi Dritës veten.
 M.NOM CL showed D.DAT self.ACC
 ‘Murat, showed Drita, himself, / herself.’

- b. Murati ia tregoi Dritën vetes t.
 M.NOM CL showed D.ACC self.DAT
 'Murat, showed himself, / *herself, Drita.'

We can attribute to Albanian long passives a derivation similar to that of the leapfrogging cases of A-scrambling described in Section 1. Instead of moving to spec-RP to check a Scr feature and Case, however, the direct object moves to check an EPP feature on R. Once in the same checking domain as the higher argument, the direct object is sufficiently local to be attracted to spec-TP. Since it has not checked Case, it can be attracted to spec-TP to check both Case and EPP. Since the direct object leapfrogs through the checking domain occupied by the indirect object, any anaphoric dependency established between these two arguments gives rise to Lethal Ambiguity.

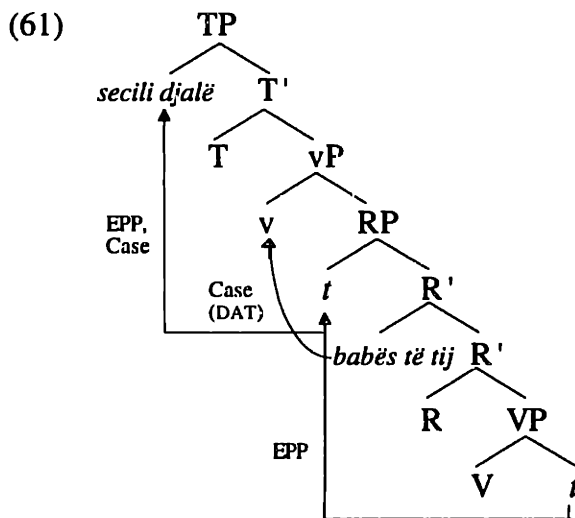

Before the direct object is attracted to T, the indirect object checks Case by feature-attraction to v . As noted above, when v is introduced into the derivation, both the direct object and the indirect object are local to v without having checked Case. Nevertheless, the only convergent derivation is one in which the indirect object checks Case on v , leaving the direct object to check Case on T. I have proposed that the indirect object must check Case on v because it is inherently specified as having dative m-case, which can be checked on v but not on T. If the direct object checks Case on v , the indirect object will be forced to check Case on T, and its m-case feature will not be properly checked, so the derivation will

crash. I assume that the indirect object checks Case by Attract rather than by Move. Thus it remains in spec-RP, so the direct object is still local for attraction to spec-TP.

The proposed derivation can be compared with the derivations proposed for ditransitive passives in Chapter 2. There I proposed that when R has an inherent Case feature, it has no EPP feature, even in a nonactive construction. Thus, when the indirect object checks inherent Case, a lower argument cannot leapfrog over it to the subject position, and is simply blocked from being attracted to spec-TP, as we saw in Greek and several Romance languages. Another possibility that can be imagined is that the dative indirect object in Albanian is “quirky,” checking m-case inherently. If so, however, it should not have to check Case on *v*, since dative subjects are well-formed in Albanian, as we saw in Chapter 2. A quirky indirect object should at least allow the possibility of moving to spec-TP; but, as we have seen, only the leapfrogging derivation is possible in Albanian passive ditransitives. For these reasons, I propose that the indirect object in Albanian checks neither Case nor m-case inherently, but rather that its m-case is inherently specified as dative, and obligatorily checked on *v*.

3.1.2 *Symmetric passives*

Long passives are also possible in other languages, including British English and Chaga. These languages have symmetric passives, in which either object can raise to the subject position. British English shares the c-command properties reported for American English in the last chapter—namely, a DP indirect object asymmetrically c-commands the direct object. British English allows short passives, as in (62a). It also permits long passives, as in (62b).

- (62) a. [Colin] was given [_{RP} *t* [_{VP} a book]] for his birthday.
 b. [A book] was given [_{RP} *t* Colin [_{VP} *t*]] for his birthday.

The theory of passives outlined here allows two mutually compatible accounts of the alternation in (62). One possibility is that Case is always suppressed on R in a passive,

and the lower argument always moves to check an EPP feature in spec-RP. However, since British English lacks any special dative m-case, it is not obvious that the indirect object is forced to check dative m-case on spec-vP. If either object can check accusative Case on v , the other object will raise to spec-TP. For example, the direct object can check Case on v , while the indirect object moves to the subject position (63).

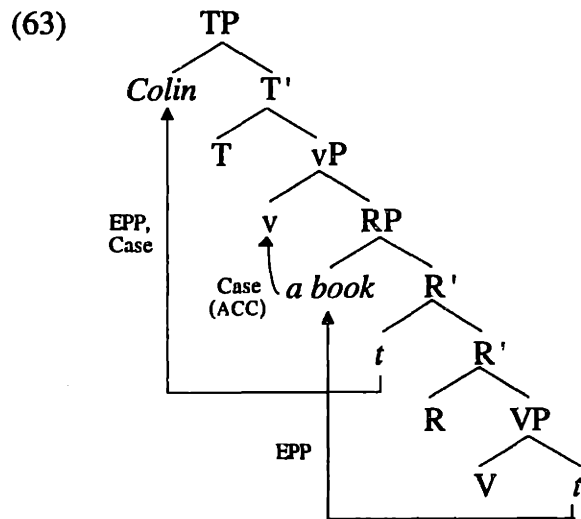

Another possible account of the symmetric passives in (62) is that British English allows Case to be suppressed on either R or v . When Case is suppressed on R, the leapfrogging derivation arises, with the lower object moving to spec-TP; when Case is suppressed on v , the lower object checks Case on R, while the higher one raises to spec-TP. In fact, these two accounts are mutually compatible, so it is also possible that British English takes advantage of both sources of optionality.

If we take the former approach—where Case is always suppressed on R, and the direct object always raises to spec-RP—then an anaphoric dependency between the two objects should be impossible. I have argued that Lethal Ambiguity rules out an anaphoric dependency in the leapfrogging derivation. In Section 4 and in the next chapter, we will see evidence that Lethal Ambiguity also arises when a lower argument raises into one specifier of a higher head, then another specifier of the same head head raises to the subject position. Thus, if the direct object always raises into spec-RP in a language with symmetric

passives, both the leapfrogging and the advancing derivations should be subject to Lethal Ambiguity between the two objects. According to my consultants, however, (64) is fine.

(64) Colin was shown himself in the mirror.

The well-formedness of this example suggests that a derivation is available in which the direct object does not check EPP in spec-RP. In well-formed derivations, a suppressed Case feature of R is always replaced by an EPP feature on R. As we saw in Chapter 2, if Case is suppressed on R and it has no EPP feature, then the direct object is trapped within VP, unable to check Case on a higher head. In our British English example, the indirect object would be able to check Case on *v*, but it would still block T from attracting the direct object. Having checked Case already, the indirect object itself would be unable to check the EPP feature of T, and the derivation would crash (65).

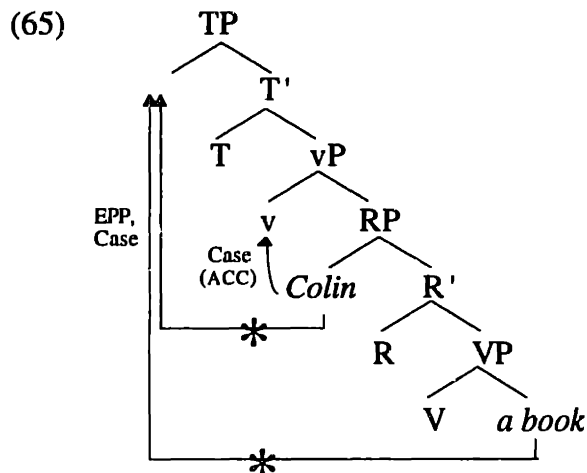

If the direct object does not check EPP in spec-RP in (64), then British English apparently allows a passive in which Case is suppressed on *v*. In such a derivation, identical to that of the passive ditransitive in American English, the direct object can check Case on R by Attract, without moving into spec-RP, while the indirect object raises directly to the subject position. Since the two arguments are never in specifiers of the same head, Lethal Ambiguity does not arise.

Of course, British English may also allow a derivation in which Case is suppressed on R and the indirect object moves to the subject position, while the direct object moves to

spec-RP to check EPP and then checks Case on ν . If such a derivation exists, we should expect to find two positions for the direct object when the indirect object has raised to the subject position in British English. One position is within VP, when the direct object checks Case on R; the other is in spec-RP, when it checks Case on ν . I leave this prediction for future investigation.

Chaga also has symmetric passives, as discussed in Chapter 1. In (66a), the indirect object raises to the subject position, triggering subject agreement on the verb, while the direct object triggers object agreement on the verb. In (66b) it is the direct object that triggers subject agreement, and the indirect object that triggers object agreement.

- (66) a. M-ka n-a-i-ki-lyi-i-o.
 wife FOC-SP-prs-OP-eat-R-PAS
 ‘The wife is being affected by someone’s eating it.’
- b. K-i-m-lyi-i-o.
 SP-prs-OP-eat-R-PAS
 ‘It (i.e., the food) is being eaten for/on him/her.’

The same two possible sources of optionality arise in Chaga, but I have been unable to test whether or not such passives are always subject to Lethal Ambiguity. If so, we can conclude that Case is always suppressed on R, and the direct object raises into spec-RP whether it checks Case on ν or on T; otherwise, we can conclude that Chaga also allows Case suppression on either R or ν .

3.2 Structural / inherent Case alternations

In the previous chapter, we observed that the highest argument can block a lower argument from being attracted to spec-TP, even when Case Identification prevents the highest argument itself from checking EPP. In some cases, however, clitic-movement or clitic-doubling of the highest argument allows a lower argument to raise past it to the subject position. The contrasting cases are shown in (67). In (67a), the experiencer is a full DP checking inherent Case, which blocks the lower embedded subject from raising to the matrix T, but which cannot itself pied-pipe to check the EPP feature of T. When the

experiencer is a clitic, however, the embedded subject successfully raises past it to the subject position (67b).

- (67) a. ?*Jean semble à Marie [*t* avoir du talent].
 J. seems to M. to have of talent
 ‘Jean seems to Marie have talent.’
- b. Jean lui semble *t* [*t* avoir du talent].
 J. 3SG.DAT seems to have of talent
 ‘Jean seems to him to have talent.’

I assume that, like full DPs, clitics of the category D check Case; in fact, I proposed in Chapter 1 that clitics check Case via Move, since the [clitic] feature identifies the whole clitic for pied-piping into a specifier of the Case-checking domain. After checking Case in a specifier, I assume that a clitic undergoes movement to a head, here T. Once a clitic has adjoined to T, both the clitic and its trace are invisible for attraction by T, so a lower argument can be attracted past them to the subject position. However, as we will see below, a derivation like (67b) with an anaphoric experiencer clitic gives rise to Lethal Ambiguity. In the next chapter, I argue that Lethal Ambiguity does not arise when one argument skips over another. Thus I propose that the derivation in (67b) involves leapfrogging, just as in an Albanian long passive.

The difference between (67a) and (67b) then reduces to differences in the properties of R and ν . In (67a), R has an inherent Case feature checked by its theta-checker, while ν has no Case feature at all. R (and ν) then have no Case feature for the embedded subject to check. However, the embedded subject in spec-VP is not local to T, since the experiencer is in a higher checking domain (spec-RP). The experiencer blocks attraction of the embedded subject, but cannot itself be attracted to spec-TP, having already checked Case in spec-RP. Accordingly, the derivation crashes, as we saw in the last chapter. In (67b), however, R merely specifies its theta-checker as morphologically dative. R here has no Case feature, inherent or otherwise, but it does have an EPP feature, which attracts the embedded subject. Meanwhile, ν checks the Case and dative m-case of the clitic. The clitic

then adjoins to T, and the embedded subject raises from spec-RP to spec-TP. This derivation is shown in (68).

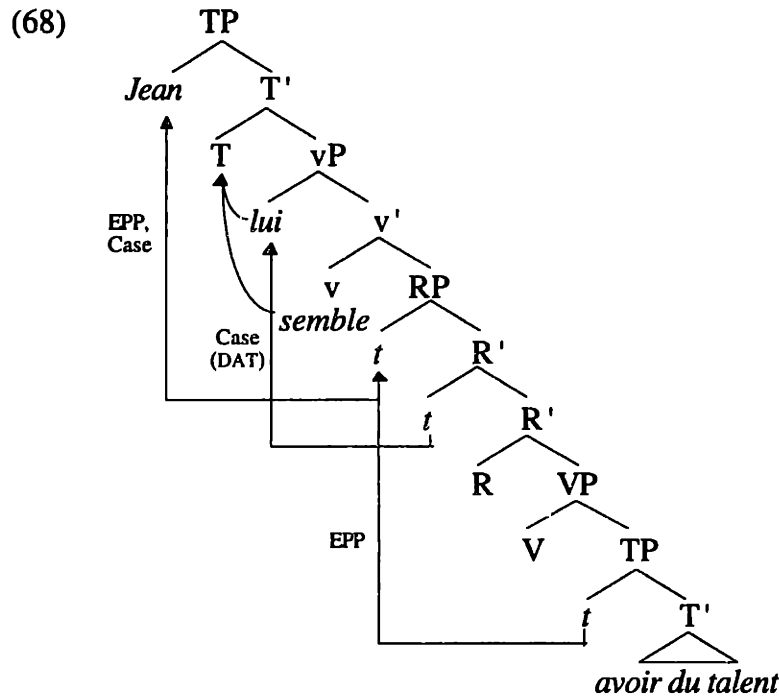

Of course, the question arises of why the clitic checks structural Case, while its full DP counterpart checks inherent Case. At present I simply leave the distinction as a stipulation. Note that if the clitic checked inherent Case, (67b) would still be a well-formed string; once the clitic adjoins to T, the embedded subject can be attracted straight across its trace from the embedded spec-TP to the matrix spec-TP. Since such a derivation would not involve leapfrogging through spec-RP, we would not expect Lethal Ambiguity to arise between the raised subject and an anaphoric clitic experiencer.

However, movement of an argument past a higher clitic does give rise to Lethal Ambiguity effects. Rizzi (1986) presents an extensive discussion of relevant facts from Italian.²³ In Italian, as in French, the embedded subject of an infinitival cannot raise past a full matrix experiencer (69a). In (69b), R has an EPP feature, so the embedded subject

²³ I also thank Sveva Besana and Michela Ippolito for their Italian judgements.

leapfrogs through spec-RP to the subject position of the matrix clause. If the clitic is anaphoric, however, the leapfrogging derivation is ill-formed.

- (69) a. ?*Gianni sembra a Piero [*t* fare il suo dovere].
 G. seems to P. to do the his duty
 ‘Gianni seems to Piero to do his duty.’
- b. Gianni le sembra [_{VP} *t* [_{RP} *t* *t* [_{TP} *t* fare il suo dovere]]].
 G. her.DAT seems to do his duty
 ‘Gianni seems to her to do his duty.’
- c. *Gianni si sembra [_{VP} *t* [_{RP} *t* *t* [_{TP} *t* fare il suo dovere]]].
 G. REFL seems to do his duty
 ‘Gianni seems to himself to do his duty.’

Under the story presented here, the ill-formedness of binding in (69c) arises from the fact that the embedded subject leapfrogs through a specifier in the same checking domain in which the experiencer clitic is merged. By Lethal Ambiguity, no anaphoric dependency can be established between the two arguments. If the clitic is an anaphor, it must be bound, but no other argument is available to bind it, so uninterpretability results. The same contrast arises in French, as shown below.

- (70) a. Jean lui semble avoir du talent.
 J. 3SG.DAT seems to have of talent
 ‘Jean seems to him to have talent.’
- b. *Jean se semble avoir du talent.
 J. REFL seems to have of talent
 ‘Jean seems to himself to have talent.’

Leapfrogging can also be observed in French and Italian double-object passives. As we saw in Chapter 2, an indirect object cannot be attracted to the subject position in either of these languages (except with French *obéir*—see Chapter 4). On the other hand, the indirect object can be generated as a PP below the direct object, allowing it to raise to the subject position (71a). Note, however, that the direct object can also raise if the indirect object is a dative clitic (71b).

- (71) a. Nos amis sont présentés à Jean-Pierre.
 our friends are presented to J.-P.
 'Our friends have been introduced to Jean-Pierre.'
- b. Nos amis lui sont présentés.
 our friends 3SG.DAT are presented
 'Our friends have been introduced to him.'

In the previous chapter, we adopted Marantz's (1993) hypothesis that a DP indirect object is always generated above a direct object. If the indirect object clitic is a DP, then, the derivation of (71b) is just like that of the Albanian long passive. The same analysis can be given to the parallel cases in Italian (72).

- (72) a. Gianni è stato affidato a Maria.
 G. has been entrusted to M.
 'Gianni was entrusted to Maria.'
- b. Gianni le è stato affidato.
 G. her.DAT has been entrusted
 'Gianni was entrusted to her.'

As predicted, these long passives are subject to Lethal Ambiguity in both languages. As the direct object raises to the subject position, it leapfrogs through the checking domain occupied by the indirect object clitic. Thus an anaphoric dependency between the two arguments is uninterpretable (73).²⁴

- (73) a. *Nos amis se sont [VP t [RP t t [VP présentés t]]].
 our friends REFL are presented
 'Our friends have been introduced to each other.'
- b. *Gianni si è [VP t [RP t t [VP stato affidato t]]].
 G. REFL has been entrusted
 'Gianni was entrusted to himself.'

Double object constructions with a clitic indirect object can be compared with those with a PP indirect object. When the indirect object is a PP, it originates below the direct object, which advances to the specifier of TP from the higher object position. In this case the direct object can bind an anaphoric indirect object, as in (74).

²⁴ (73a) is grammatical on another reading, 'Our friends introduced themselves.'

- (74) a. Gianni è stato affidato *t* a se stesso.
 G. has been entrusted to himself
 'Gianni was entrusted to himself.'
- b. I nostri amici sono stati presentati *t* l'uno all'altro.
 the our friends have been introduced to each other
 'Our friends have been introduced to each other.'

(74a) has the interpretation intended for the ungrammatical example with an anaphoric clitic in (73b). In (74), however, there is no need for the direct object to leapfrog over the indirect object (or vice versa), so no Lethal Ambiguity arises.

Rizzi notes that the same contrast also appears in an arbitrary-*si* passive of a double object construction in Italian. Italian has two arbitrary-*si* constructions, an active construction where *si* is (or doubles) the nominative subject, and a passive-like construction with *si* where the verb is in the form of the active, but an internal argument becomes the subject, triggering subject-verb agreement. We will return to these constructions in Chapter 4. For the moment, the point to notice is that in the *si*-passive, as in the participial passive, the indirect object cannot be an anaphoric clitic (75b). A sequence consisting of the arbitrary and anaphoric clitics is spelled out as *ci si* (see Bonet 1991 for discussion).

- (75) a. Gli si affideranno *t* i due bimbi.
 him.DAT ARB will entrust the two children
 'The two children will be entrusted to him.'
- b. *Ci si affideranno *t* i due bimbi.
 REFL ARB will entrust the two children
 'The two children will be entrusted to each other.'
- c. Si affideranno i due bimbi l'uno all'altro.
 ARB will entrust the two children to each other
 'The two children will be entrusted to each other.'

A pronominal indirect object clitic is fine, as in (75a), but an anaphoric clitic yields an ill-formed derivation, as in (75b).²⁵ Again, this contrast can be attributed to Lethal Ambiguity if we assume that the direct object leapfrogs through spec-RP, preventing any anaphoric dependency with the indirect object. If the indirect object is a PP, however, it can be generated below the direct object, so no leapfrogging takes place and no Lethal Ambiguity arises.

3.3 Clitic Doubling

In the previous section, we observed a contrast between full DP arguments checking inherent Case and clitic arguments checking structural Case. In Greek, a clitic-doubled argument behaves exactly like a clitic: it checks structural Case on v , and in a passive a lower argument can leapfrog over it through spec-RP to the subject position. The same is not true in all clitic-doubling languages. Torrego (1996) points out that a clitic experiencer in Spanish blocks raising of a lower embedded subject, by contrast with French and Italian. She argues that the difference is due to the fact that clitic-doubling exists in Spanish, but not in French and Italian. As we will see below, however, clitic-doubled arguments in Greek behave just like clitics in French and Italian. I propose that the real difference is in the properties of R and v . In French, Italian and Greek, there is an alternation between experiencers checking structural Case on v , and those checking inherent Case on R. In Spanish, there is no alternation; the experiencer always checks inherent Case. As postulated above, R with inherent Case has no EPP feature to attract a lower argument. Consequently, an embedded subject cannot leapfrog over the experiencer argument in Spanish.

²⁵ For my consultant, the arbitrary interpretation of *si* in these examples is possible only when the subject is postverbal, so I give (75b) as a minimal contrast. Rizzi actually gives example (i) instead, perhaps because here the antecedent c-commands the reflexive. He reports that (i) is grammatical on another reading, where *ci* is the first-person plural: 'The two children will be entrusted to us.' This reading is not available for my consultant. Thanks to Sveva Besana for her help with these examples.

(i) *I due bimbi ci si affideranno t t.
 the two children REFL IMP will entrust
 The two children will be entrusted to each other.'

Let us begin with clitics in Greek. The contrast observed above for raising constructions also occurs in Greek (Anagnostopoulou 1997). As we saw in Chapter 2, the inherent Case-checking experiencer in (76a) blocks an embedded subject from raising. However, constructions like (76b) are well-formed. Here the clitic experiencer checks Case on *v*, as in French and Italian, while the embedded subject leapfrogs through spec-RP to the matrix subject position.

- (76) a. * O Jannis fenete tis Marias [*t* eksipnos].
 the J.NOM seems the M.DAT intelligent
 ‘John seems to Mary intelligent.’
- b. O Jannis tis fenete [*t* eksipnos].
 the J.NOM her.DAT seems intelligent
 ‘John seems to her intelligent.’

The examples in (76) involve a lower argument in an embedded adjectival predicate. The same paradigm can also be observed when the lower argument is the subject of an embedded clause. Greek lacks infinitivals, so the embedded verb is in the subjunctive.

- (77) a. * Ta pedhia dhen fenonte tis Marias [*t* na dhiavazoun].
 the children.NOM not seem.3PL the M.DAT SUBJ read.3PL
 ‘The children do not seem to Mary to study.’
- b. Ta pedhia dhen tis fenonte [*t* na dhiavazoun].
 the children.NOM not her.DAT seem.3PL SUBJ read.3PL
 ‘The children do not seem to her to study.’

Greek is an interesting case, since it allows the embedded argument to raise even past a full DP experiencer, provided that the experiencer is clitic-doubled (78).

- (78) a. O Jannis tis fenete tis Marias [*t* eksipnos].
 the J. her.DAT seems the M.DAT intelligent
 ‘John seems to Mary to be intelligent.’
- b. Ta pedhia dhen tis fenonte tis Marias [*t* na dhiavazoun].
 the children.NOM not her.DAT seem.3PL the M.DAT SUBJ read.3PL
 ‘The children do not seem to Mary to study.’

These constructions are exactly parallel to those with clitic-movement (76-77). When a full DP experiencer is clitic-doubled, as here, the embedded subject leapfrogs past it to the subject position, and triggers agreement on the higher verb. As predicted, no anaphoric dependency can be established between the raised subject and the experiencer. An anaphor can be clitic-doubled in Greek (Iatridou 1988); a well-formed example is shown in (79a). However, the raised subject cannot bind the experiencer.²⁶

- (79) a. O Costas ton thavmazi ton eafton tu.
 the C. him.ACC admires the self.DAT his.GEN
 'Costas admires himself.'
- b. *O Jannis tu fenete tu eafu tu [t eksipnos].
 the J. him.DAT seems the self.DAT his.GEN intelligent
 'John seems to himself to be intelligent.'

We might ask what is the position of the clitic-doubled argument in Greek.

Anagnostopoulou (1994) contends that such arguments can occupy an A-position, rather than being restricted to a right-dislocated A-bar position. First, she shows that a clitic-doubled argument does not always occupy the stressed, right-dislocated position. (80a) shows a doubled direct object, followed by a postverbal subject bearing main stress. A doubled indirect object also can be followed by a postverbal subject (80b).

- (80) a. To diavase to vivlio i Maria.
 it.ACC read the book.ACC the M.NOM
 'Mary read the book.'
- b. Tu dothike tu Janni to vivlio apo tin Maria.
 him.DAT was given the J.DAT the book.NOM by the M.ACC
 'The book was given to John by Mary.'

With respect to the possibility of occupying an A-position, there is a contrast between clitic-doubled definite and indefinite direct objects in Greek, which does not apply to indirect objects. Definite objects can be clitic-doubled from an A-position. Indefinite direct objects

²⁶ Greek judgements are from Elena Anagnostopoulou, p.c. Anagnostopoulou notes that dative anaphors are never possible in Greek. Everaert & Anagnostopoulou (1996) argue that this is for thematic reasons. An interesting alternative possibility is that they are entirely ruled out by Lethal Ambiguity. I have not explored the full consequences of this possibility here.

can be clitic-doubled only under right-dislocation, as in (81a). A doubled indefinite object followed by a postverbal subject is thus ungrammatical (81b), by contrast with (80b).

Doubled definite objects and indirect objects are not subject to this restriction, since they are not confined to right-dislocation structures.

- (81) a. To diavase i Maria ena vivlio.
 it.ACC read the M.NOM a book.ACC
 'Mary read a book.'
- b. *To diavase ena vivlio i Maria.
 it.ACC read a book.ACC the M.NOM
 'Mary read a book.'

Anagnostopoulou (1997) argues that in cases like (81a), clitic-doubling involves feature-movement from an argument position to a head. Under the theory proposed here, it also correlates with structural Case for the dative argument—and, in nonactives, an EPP feature on R. I assume that the clitic represents the Case and phi-features of the argument, which check Case in spec-*v*P, leaving behind the remaining features of the doubled argument in spec-RP.²⁷ The direct object in (81a) checks Case on R. In a nonactive, this Case feature is replaced by an EPP feature, and the lower argument leapfrogs over the clitic-doubled full DP experiencer. By contrast, French and Italian lack clitic-doubling; in these languages a full DP experiencer in an A-position always checks inherent Case, and always blocks raising of the embedded subject.

The raising cases shown above demonstrate that a clitic-doubled argument is treated in the same way as a bare clitic in Greek, in being associated with the leapfrogging derivation. Parallel facts can be observed in double object passives and in unaccusatives with two internal arguments. For most verbs in Modern Greek, only the direct object can raise to the subject position of a double-object passive (Joseph & Philippaki-Warburton 1987:168). As we saw in Chapter 2, a full dative DP blocks the direct object from raising

²⁷ This account is a simplification. Anagnostopoulou (1997, 1998) provides binding evidence to suggest that clitic-movement in Greek actually involves attraction of the doubled argument's D-features to T, allowing a lower argument to skip over this argument without leapfrogging through spec-RP. Under such an account, the observed restrictions on anaphora in Greek could not be attributed to Lethal Ambiguity.

(82a). When the indirect object is a clitic, however, the direct object leapfrogs over it to the subject position (82b).

- (82) a. *?To vivlio dothike tu Janni apo tin Maria.
 the book.NOM was given the J.DAT by the M.ACC
 'The book was given to John by Mary.'
- b. To vivlio tu dothike apo tin Maria.
 the book.NOM him.DAT was given by the M.ACC
 'The book was given to him by Mary.'

Movement of the direct object is also well-formed if the indirect object is clitic-doubled, as in (83a). However, the raised direct object cannot bind a doubled indirect object (83b). In the active construction, the indirect object can bind the direct object, as shown in (83c).

- (83) a. To vivlio tu dothike tu Janni apo tin Maria.
 the book.NOM him.DAT was given the J.DAT by the M.ACC
 'The book was given to John by Mary.'
- b. *O Jannis tu dixtike tu eaftu tu apo ton kalitexni
 the J.NOM him.DAT was shown the self.DAT his.GEN by the artist.ACC
 'John was shown to himself by the artist.'
- c. O kalitexnis tu edikse tu Janni ton eafton tu.
 the artist.NOM him.DAT showed the J.DAT the self.DAT his.ACC
 'The artist showed John, to himself.'

The contrast between full DPs and clitics also holds if only the features of the nominative argument are attracted to the subject position. As in the cases with overt Move, the direct object can be attracted past an indirect object only if this indirect object is a clitic or clitic-doubled. The examples in (84) also illustrate that the clitic-doubled dative argument is not in a right-dislocated position, since it can be followed by a postverbal subject, as well as by other material.

- (84) a. *?Dothike tu Janni to vivlio apo tin Maria.
 was given the J.DAT the book.NOM by the M.ACC
 'The book was given to John by Mary.'
- b. Tu dothike to vivlio apo tin Maria.
 him.DAT was given the book.NOM by the M.ACC
 'The book was given to him by Mary.'
- c. Tu dothike tu Janni to vivlio apo tin Maria.
 him.DAT was given the J.DAT the book.NOM by the M.ACC
 'The book was given to John by Mary.'

In Chapter 2, I assumed that examples like (84a) are ill-formed because the lower argument cannot check Case, even if a (null) expletive is able to check the Case and EPP features of T. By comparison, the well-formedness of (84b-c) indicates that the direct object does check Case on T in these examples; thus, we cannot suppose that a null expletive checks the Case of T in these postverbal-subject constructions. Rather, it appears that the Case feature of the direct object is attracted to T, although the direct object itself is in a postverbal position. We might ask, then, what prevents T from attracting the Case feature of the direct object in (84a). The indirect object is a closer DP, so it should block attraction of the direct object for EPP; but since the direct object need not satisfy EPP in (84a-b), we can assume it need not do so in (84a) either. Recall that in (84a), the indirect object checks (and deletes) its Case feature when it merges in spec-RP. If nothing but a Case feature is to be attracted to T, the closest Case feature is then that of the direct object. Nevertheless, this Case feature apparently cannot be attracted, since the derivation is ill-formed. Examples of this kind are one source of motivation for saying that the Case feature of a head attracts both the Case and phi-features of a lower argument. Although the Case feature of the indirect object is checked and deleted, its phi-features remain intact, and it is these that block attraction of the Case and phi-features of the direct object in (84a).²⁸

It should be recalled that the ungrammaticality of (83a) and (84a) cannot be attributed to a general requirement that dative arguments must be clitic-doubled. In the active counterpart of these clauses, for example, clitic doubling is optional (85).

- (85) (Tu) edosa tu Janni to vivlio.
 (him.DAT) gave-I the J.DAT the book.ACC
 'I gave the book to John.'

²⁸ A parallel case can be constructed in the traditional "superraising" paradigm, which deals with ill-formed movement out of a finite clause. *Believe* is an ECM verb, having a ν head that can check the Case of an embedded subject. Note that the phi-features of the expletive in (i) block *him* from being attracted to check Case on ν in the ECM clause, although the Case feature of the expletive is already checked and deleted by the time matrix ν is added to the derivation.

(i) *I believe [that it is likely [him to have written a novel]].

A similar array of facts arises with unaccusatives having a dative argument. A full dative DP gives rise to ungrammaticality (86a), but a dative clitic allows the theme to leapfrog over it to the subject position (86b).

- (86) a. * To gramma irthe tis Marias me megali kathisterisi.
 the letter.NOM came the Mary.DAT with a big delay
 'The letter came to Mary with a big delay.'
- b. To gramma tis irthe me megali kathisterisi.
 the letter.NOM her.DAT came with a big delay
 'The letter came to her with a big delay.'

The theme can also raise to the subject position if the dative argument is clitic-doubled (87a). As before, the raised argument cannot bind a doubled dative anaphor (87b).

- (87) a. O iposifios tis parusiastike tis Marias.
 the candidate.NOM her.DAT appeared the M.DAT
 'The candidate appeared to Mary.'
- b. * I Maria tis parusiastike tu eafu tis.
 the M.NOM her.DAT appeared the self.DAT her.GEN
 'Mary appeared to herself.'

Again, the contrast between full dative DPs and clitic or clitic-doubled ones also holds when T attracts only Case and phi-features, as in (88).

- (88) a. * Irthe tis Marias to gramma me megali kathisterisi.
 came the Mary.DAT the letter.NOM with a big delay
 'The letter came to Mary with a big delay.'
- b. Tis irthe to gramma me megali kathisterisi.
 her.DAT came the letter.NOM with a big delay
 'The letter came to her with a big delay.'
- c. Tis irthe tis Marias to gramma me megali kathisterisi.
 her.DAT came the Mary.DAT the letter.NOM with a big delay
 'The letter came to Mary with a big delay.'

As we have seen, derivations with a clitic-doubled dative argument in Greek behave exactly like those with a dative clitic. The dative argument checks structural Case, and the EPP feature on R allows a lower argument to leapfrog through spec-RP to the subject position. Greek contrasts with Spanish in this respect (Torrego 1996). In Spanish, even a

clitic experiencer blocks movement of the embedded subject.²⁹ Raising from the embedded clause is fine if there is no experiencer, as in (89a), and an experiencer is fine if the complement clause is finite, so that no raising occurs, as in (89b). However, raising with an experiencer is ungrammatical (89c).

- (89) a. Este taxista parece [*t* estar cansado].
 this taxi driver seems to be tired
 ‘This taxi driver seems to be tired.’
- b. Me parece [que este taxista esta cansado].
 me.DAT seems that this taxi driver is tired
 ‘It seems to me that this taxi driver is tired.’
- c. *Este taxista me parece [*t* estar cansado].
 this taxi driver me.DAT seems to be tired
 ‘This taxi driver seems to me to be tired.’

Torrego attributes the ungrammaticality of (89c) to the fact that Spanish, unlike French and Italian, has clitic-doubling.³⁰ She cites preliminary confirmation of this hypothesis in Catalan, Galician, and Romanian. However, this account is not consistent with the Greek facts. I propose instead that in Spanish, even a clitic-doubled experiencer must check inherent Case on R, which lacks an EPP feature even in the nonactive.

By this view, the structure of a raising construction with a clitic experiencer in Spanish is essentially the same as the structure in French and Italian where the experiencer is a full DP. For many speakers such constructions are dispreferred, as noted above.

- (90) a. ?*Gianni sembra a Piero [*t* fare il suo dovere].
 G. seems to P. to do the his duty
 ‘Gianni seems to Piero to do his duty.’
- b. *Este taxista me parece *pro* [*t* estar cansado].
 this taxi driver me.DAT seems to be tired
 ‘This taxi driver seems to me to be tired.’

²⁹ Soriano (1997) confirms these judgements.

³⁰ Torrego’s account of raising constructions also makes use of relativized locality, but it relies on the claim that the experiencer is in an adjunct position cross-linguistically. I take the fact that the experiencer can raise to the subject position in Icelandic as evidence against this claim.

In each case, the presence of a quirky experiencer blocks movement of the embedded subject. Torrego (1995) argues that even when no overt doubled argument corresponds to the clitic in (90b), a null *pro* argument must be present in the doubled argument position. The *pro* experiencer behaves just like the overt experiencer of the corresponding construction in (90a): its D and phi-features are attracted to T, blocking attraction of the lower argument. Since Case Attraction blocks the experiencer from pied-piping to check EPP once it has checked Case in spec-RP, the derivation crashes.³¹

4 Overt Movement of Lower Argument

The last section was devoted to cases in which a lower argument leapfrogs over a higher one to the subject position. In this section, I will discuss cases in which a lower argument raises into the checking domain occupied by a higher one, but the higher argument raises to the subject position.³² These are situations in which the lower argument checks Case by moving into the same checking domain as the higher argument. Under the generalization I have proposed for Lethal Ambiguity, such a configuration should disallow an anaphoric dependency between the two arguments. This prediction appears to be confirmed. Rizzi (1986) shows that Lethal Ambiguity arises in several cases where a lower anaphoric clitic raises into a checking domain occupied by a higher argument.

For example, consider an unaccusative with a theme argument and a prepositional phrase that allows stranding, as in (91). In (91a) the object of the preposition *addosso* is a clitic. No anaphoric dependency can be established between the two arguments, so if the

³¹ For a different view, see Soriano (1997), who proposes that the dative experiencer can raise to subject position if the embedded clause is finite. Soriano's claim is contrary to that of Torrego (1996), who suggests that all constructions with raising verbs in Spanish have an expletive subject.

³² These are cases of advancing, rather than leapfrogging, but I have postponed discussion of them to this point for two reasons: first, because they give rise to Lethal Ambiguity effects, which were not argued for until this chapter; and secondly, because they raise a number of further questions that will not be addressed until the next chapter.

clitic is an anaphor, as in (91b), the derivation is uninterpretable. (91c) has the desired interpretation for (91b). Here, binding the anaphor does yield an interpretable derivation.

- (91) a. Il ladro e il poliziotto gli sono caduti [_t t [addosso t.]].
 the thief and the policeman him.DAT are fallen on
 ‘The thief and the policeman fell on him.’
- b. * Il ladro e il poliziotto si sono caduti [_t t [addosso t.]].
 the thief and the policeman RECIPIENT are fallen on
 ‘The thief and the policeman fell on each other.’
- c. Il ladro e il poliziotto sono caduti [t [l’uno addosso all’altro]].
 the thief and the policeman are fallen on each other
 ‘The thief and the policeman fell on each other.’

Suppose that the clitic in (91a-b) raises out of the PP to check Case in the checking domain occupied by the theme.³³ If so, Lethal Ambiguity should arise between the two arguments. In (91c), the anaphor is a full DP, so it checks Case by Attract, and Lethal Ambiguity does not arise.

Another case of Lethal Ambiguity arises between direct and indirect object clitics in an active clause. As argued above, an indirect object clitic is a DP generated higher than the direct object. If the direct object is a clitic, it checks Case in an active clause by moving to spec-RP, where it occupies the same checking domain as the indirect object. No anaphoric dependency can be established between the two objects, as shown in (92b). When only the indirect object cliticizes, it can bind the direct object, since the two arguments never occupy specifiers of the same head (92c). These examples are from Sveva Besana (p.c.).

- (92) a. Gianni glielo affiderà.
 G. 3SG.DAT+him.ACC trusted
 ‘Gianni entrusted him to him/her.’
- b. * Gianni gli si affiderà.
 G. him.DAT REFL entrusted
 ‘Gianni_i entrusted him_j to himself_{ij}.’

³³ Assuming that V assigns a theta-role to the theme, this means V can have a Case feature for a lower argument to check.

- c. Gianni gli affiderà se stesso.
 G. him.DAT entrusted himself
 'Gianni_i entrusted him_j to himself_{ij}.'

The derivation of (92a) is shown in (93).

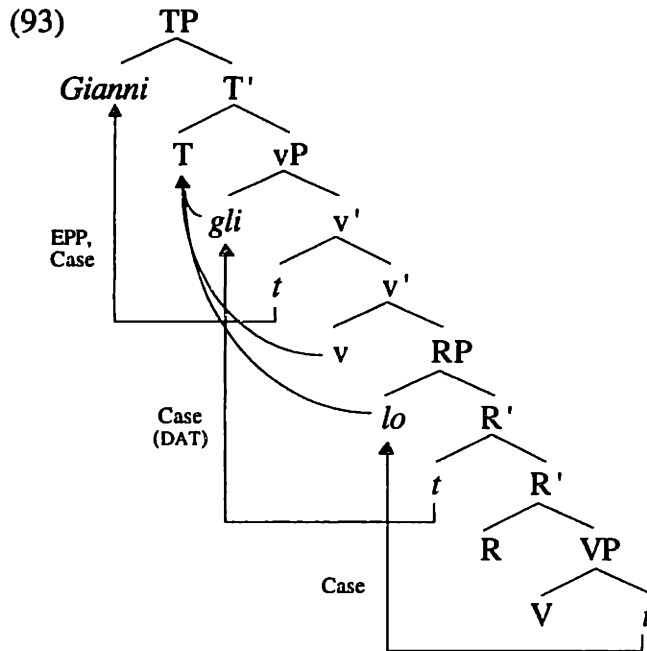

Notably, the anaphoric direct object in (92b) also cannot be bound by the external argument. This situation contrasts with the cases of A-scrambling below the level of the subject. We saw in Georgian that when a direct object A-scrambles over an indirect object, the indirect object can still be bound by the external argument (94).

- (94) Nino-m gela tavis tav-s t a-nax-a sarkeši.
 N.-ERG G.NOM self-DAT R-show-AOR mirror.in
 'Nino_i showed Gela_j to herself_i / *himself_j in the mirror.'

I attribute the contrast between (92b) and (94) to a morphological constraint, the **me lui* constraint discussed for example by Bonet (1991). In a number of Romance (and other) languages, certain clitics cannot cooccur with a dative third-person clitic. If anaphoric *se* is one such clitic, the ill-formedness of (92a) is expected even when Lethal Ambiguity fails to rule it out.

Other cases where binding is ruled out also arise from sources other than Lethal Ambiguity. To bind an anaphor, an argument must be in a c-commanding A-position.

Consider a derivation similar to (92a), except that the indirect object is an anaphoric clitic. If the direct object is also a clitic, as in (95a), it leapfrogs through a spec-RP to check Case before cliticizing to T. This movement gives rise to Lethal Ambiguity. However, if the direct object remains in its base position, it is not in a position to bind the anaphor. The ungrammaticality of (95b) thus arises from the fact that the anaphoric indirect object clitic c-commands the direct object, and so cannot be bound by it.³⁴ If the indirect object is a PP, it originates and remains in a checking domain below that of the direct object, and so can be bound by it, as in (95c).

- (95) a. *Si lo inimicherò.
REFL him.ACC I will turn against
'I will turn him against himself.'
- b. *Si inimicherò Gianni.
REFL I will turn against G.
'I will turn Gianni against himself.'
- c. Inimicherò Gianni a se stesso.
I will turn against G. to himself
'I will turn Gianni against himself.'

In another case where Lethal Ambiguity is predicted to apply, the prediction turns out to be difficult to test. In Chapter 2, we saw that an object can shift over the subject in Icelandic (96). Thus we might expect to find Lethal Ambiguity effects between the subject and a shifted object.

- (96) [_{CP} Það lásu [_{TP} *t*] [_{VP} [þessar bækur] aldrei neinir stúdentar [_{VP} *t*] í fyrra]]].
there read these books never any students last year
'No students ever read these books last year.' (Jonas 1998)

However, no such effects arise. The examples below show a transitive clause with an unshifted (97a) and shifted (97b) object. The shifted anaphor in (98b) is perfectly acceptable, and just as good as its unshifted counterpart in (98a) (Olafur Jonsson, p.c.).

³⁴ As we will see in Chapter 4, examples similar to (92b) are grammatical where coreference is between the external argument and the indirect object. However, there is evidence that such examples have quite a different derivation.

- (97) a. I speglinum ser Höskuldur ekki Helga.
 in the mirror see H.-NOM not H.-ACC
 'Höskuldur does not see Helga in the mirror.'
- b. I speglinum ser Höskuldur Helga ekki *t*.
 in the mirror see H.-NOM H.-ACC not
 'Höskuldur does not see Helga in the mirror.'
- (98) a. I speglinum ser Höskuldur ekki (sjalfan) sig.
 in the mirror see H.-NOM not self-ACC
 'Höskuldur does not see himself in the mirror.'
- b. I speglinum ser Höskuldur (sjalfan) sig ekki *t*.
 in the mirror see H.-NOM self-ACC not
 'Höskuldur does not see himself in the mirror.'

Holmberg & Platzack (1995) and Holmberg (1997) argue that the shifted object position in Scandinavian languages is not an A-position. The evidence for this claim is that a shifted object cannot bind into a VP-adjunct such as "to his surprise." If the shifted object is in an A-bar position, we need not assume that it checks Case overtly in a specifier of *v*. As we saw in Section 2, an A-bar moved argument can check Case by attraction to a head, so that no Lethal Ambiguity effects arise. However, the facts in (99) suggest that the object does shift to an A-position. *Aldrei* 'never' is a medial adverb in Icelandic, which can only be generated above the object (see, e.g., Bobaljik 1995). When the object raises in a passive, it can bind into an adjunct such as *aldrei i lifi sinu* 'never in his life' (99a). The unshifted object of a transitive clause cannot bind the anaphor in this adjunct, so (99b) is ill-formed. However, if it shifts to the left, binding is again fine (99c). Since new binding relations can only be created by A-movement, I conclude that Icelandic object shift does involve A-movement.

- (99) a. Jon sast [aldrei i lifi sinu] *t*.
 └──────────────────────────────────┘
 J.NOM was seen never in his life
 'Jon was seen never in his life.'
- b. *Eg sa [aldrei i lifi sinu] Jon.
 I saw never in his life J.ACC
 'I saw Jon never in his life.'

- c. Eg sa Jon [aldrei i lifi sinu] *t*.
 I saw J.ACC never in his life
 'I saw Jon never in his life.'

However, these facts pose a problem for the account given here only if we assume that there is a single position for the shifted object in Icelandic, namely a specifier of *vP*, in the same checking domain as the external argument. If this were so, the absence of Lethal Ambiguity effects would be counterevidence to the proposed environment for Lethal Ambiguity. However, there is evidence that an object can be shifted to a position below the base position of the subject, at least in some languages (Bobaljik 1995).³⁵

Bobaljik gives evidence of this kind from German, by extending Diesing's (1990, 1992) analysis of subject positions to objects. Diesing argues that there are two subject positions in German, associated with different interpretive effects. The lower position allows an existential interpretation not available in the higher position. Sentential adverbs like *ja doch* 'indeed' intervene between the two positions. Bobaljik observes that the same interpretive contrast arises between two positions for objects: the existential interpretation is possible only when the object is below a manner adverbial like *sorgfältig* 'carefully.'

Above this position, objects allow only a generic interpretation (100).

- (100) ...weil Kinder <Äpfel> sorgfältig <Äpfel> essen.
 ...since children apples carefully apples eat
 GENERIC EXISTENTIAL
 (or GENERIC)

- Generic: '...since children (generally) eat apples carefully.'
 Existential: '...since some children are eating some apples carefully.'
 or '...since children eat some (kinds of) apples carefully.'

By Diesing's analysis, the lower position for the subject is VP-internal, while the higher position is VP-external; the subject raises out of the VP to escape "existential closure."

³⁵ Under this analysis, *ekki* 'not' could not be considered to diagnose the left edge of the *vP*. Bobaljik & Jonas (1996) point out that adverb placement is not a perfectly reliable diagnostic for structure (cf. Iatridou 1990). Bobaljik (1995) also gives an argument from Icelandic that the object shifts to a position below the base position of the subject, but this argument is based on the absence of object-subject order. As noted above, Jonas (1996, 1998) reports that object-subject order is in fact possible in Icelandic.

Applying the same analysis to objects, Bobaljik makes the clear prediction that a shifted generic object should move to a position above an unshifted existential subject.

In fact, however, although the object *Äpfel* in (101) is obligatorily generic, and therefore shifted, it is still lower than an existential subject:

(101) ...weil ja doch [_{νP} Kinder [_{FP} Äpfel sorgfältig [_{νP} t essen]]].

...since indeed children apples carefully eat

'Since there are indeed (some) children who (generally) eat apples carefully.'

Obviously, Diesing's account of existential closure cannot be straightforwardly extended to objects, since if there is a single domain of existential closure for subjects and objects, and the overt position of the subject is inside this domain, the overt position of the object in (101) cannot be outside this domain. In any case, however, the generic interpretation of the object appears to be obligatory in a shifted position which is below the unshifted position of the subject. If we assume that the unshifted subject is in spec- ν P, then it appears that the object can shift to a position below ν P (the specifier of some functional head F). If so, then the fact that the subject can bind a shifted object poses no problem for the account here.

When the subject binds the object, the object is in a position below ν P. When the object does shift as high as ν P, this account predicts that Lethal Ambiguity will rule out binding.

Before concluding this chapter, I will mention one final prediction of the approach taken here. If a clitic checks Case overtly on its way to adjoin to T, then we would expect Lethal Ambiguity between the external argument and an object clitic. At first glance, this prediction seems problematic, since the external argument can bind an object in a transitive structure with an anaphoric clitic. In (102a), the external argument is merged in a specifier of ν P. The clitic checks the Case feature of ν in a specifier of ν P before adjoining to T, and the external argument raises to spec-TP. Under the assumptions outlined so far, we might assume that (102b) has the same derivation—yet no Lethal Ambiguity arises between the subject and the direct object.

- (102) a. Gianni la guarda t.
 G. her.ACC sees
 'Gianni sees her.' ↙
- b. Gianni si guarda.
 Gianni REFL sees
 'Gianni sees himself.'

In fact, there is evidence from the literature that the anaphoric clitic in (102b) is *not* an object clitic, by contrast with the pronominal clitic in (102a) (Grimshaw 1982, Marantz 1984, Kayne 1986, Snyder 1992). This evidence suggests that (102b) has a passive-like derivation, in which the syntactic subject originates in the direct object position. The theta-role of the external argument is assigned to the anaphoric clitic, but the direct object does not leapfrog through a specifier of ν P to check either Case or EPP features on its way to the syntactic subject position in spec-TP. These cases deserve a fuller discussion, so I leave them to the next chapter.

Chapter 4

Skipping

In the previous chapters, I have argued that locality plays a key role in determining which argument raises to an available subject position. In Chapter 2, I showed that the highest argument is always preferred to lower arguments, provided that it has features for checking the Case and EPP features of T. Even when a higher argument does not have a Case feature to check on T, it nevertheless blocks a lower argument from raising into the subject position. In order to be sufficiently local to be attracted to the subject position, a lower argument must move into the checking domain occupied by the higher argument.

Leapfrogging would not be necessary if locality played no role in the syntax—if, for example, movement to the subject position were determined solely by Case. It is necessary because, under locality, the categorial feature of the higher argument blocks attraction of the lower one. The principal evidence I offered for leapfrogging to the subject position was Lethal Ambiguity: if one or both of two arguments in the same checking domain is attracted out, no anaphoric dependency can be established between them.

By contrast, Rizzi (1986) argues that any movement of a lower argument over a higher one gives rise to what I have called Lethal Ambiguity effects, provided that the arguments and their traces are in a sequence of c-commanding elements. If this claim were correct, then we would have no evidence for leapfrogging—only evidence for movement of one argument over another. However, in this chapter I will argue that when one argument skips over another without leapfrogging through the same checking domain, Lethal Ambiguity does not arise, even if the arguments and their traces are in a chain of c-commanding elements. Thus we can maintain the key distinction drawn in this thesis between skipping and leapfrogging. Leapfrogging generally arises when the higher argument is of the same category as the lower one, so that the lower one must move into the same checking domain in order to be attracted past it. Skipping arises when the higher

argument lacks any features that could be attracted by T. Under a purely Case-based story of movement to the subject position, there would be no reason to expect the observed difference between derivations in which a lower DP moves past, say, a higher PP, and derivations in which it moves past a higher argument with a checked Case feature. Feature-based locality provides a way to understand the differences between these derivations.

A lower argument can skip over a higher one only if the higher one lacks any feature that could check a feature of T. In our terms, this would be an argument lacking both Case and D-features.¹ By feature-based locality, a non-DP, Caseless argument does not block attraction of a lower DP argument. Thus neither Case nor locality forces the lower argument to bypass the higher one by leapfrogging through the same checking domain; it simply skips over the higher argument. This kind of movement will not give rise to Lethal Ambiguity effects, so the moved argument can bind the non-DP argument with no difficulty. In the following sections I present several potential instances of non-DP arguments. The first involves anaphoric clitics generated in the specifier of ν , which allow a lower argument to raise to the subject position without giving rise to Lethal Ambiguity effects. As we will see, these cases contrast with pronominal clitics generated in object position. Object clitics must check structural Case in a specifier of ν P, forcing Lethal Ambiguity with the external argument. Additional instances of non-DP arguments include the experiencer in a raising construction in English, and an unaccusative construction in Georgian with two internal arguments, where the lower argument raises past the higher one to the subject position.

1 Anaphoric Clitics

As noted at the end of the last chapter, it has been argued in the literature that an anaphoric clitic or affix like that in (1a) is not an object clitic like the one in (1b) (Marantz 1984,

¹ This may be an oversimplification—there may be EPP features that attract P. These would give rise to PP subjects, for example as in locative inversion (Bresnan 1994).

Kayne 1988, Baker 1988a, Snyder 1992, Embick 1997). Rather, it is claimed, the anaphoric clitic is the external argument, and the object raises to the syntactic subject position, as in a passive.

- (1) a. Gianni si guarda *t*.
 Gianni REFL sees
 'Gianni sees himself.'
- b. Gianni la guarda *t*.
 G. her.ACC sees
 'Gianni sees her.'

In this section I will review some of the evidence that the anaphoric clitic in (1b) is the external argument, rather than the object. I will also show that the account of Lethal Ambiguity in Chapter 3 explains why the anaphoric clitic *cannot* be generated as the object. I will argue that in the well-formed derivation (1b), the anaphoric external argument is a non-DP argument.

The derivation I propose for (1b) is shown in (2). The anaphoric clitic is generated in the specifier of ν P. As a non-DP argument, it has no Case feature to check; instead it simply cliticizes to T. The object is therefore the closest eligible argument for attraction to the subject position. This means that, for the purposes of locality, the lower argument need not move through a higher position in a specifier of ν P on its way to the subject position. Moreover, since this argument checks Case on T, we cannot suppose that it is attracted to spec- ν P for Case-checking, assuming that an argument can check Case only once. Let us suppose, then, that this ν lacks any features that would attract the lower argument. The argument moves straight from its base position into a specifier of TP. As a result, Lethal Ambiguity between the two arguments does not arise, and the raised object can bind the anaphoric external argument.

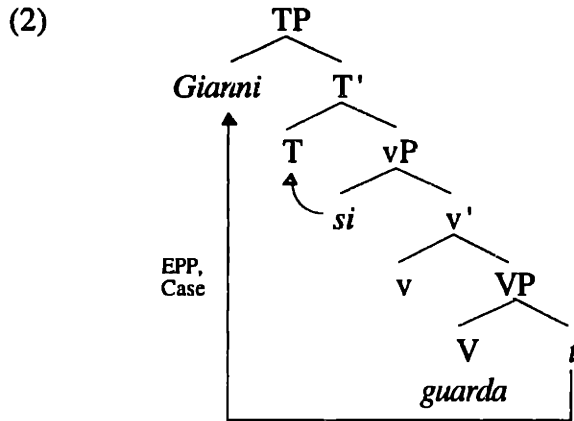

As we will see, some proposal of this kind is needed to account for well-formed constructions with an anaphoric clitic. A derivation in which the anaphoric clitic is generated as a regular object clitic is blocked by Lethal Ambiguity. The same constraint also blocks a derivation in which the object (*Gianni* in (2)) moves to the subject position via a specifier of *vP*.

There is considerable evidence demonstrating the different syntactic behaviour of anaphoric clitics and (clitic or nonclitic) objects. Transitive constructions with an anaphoric clitic or affix share properties with passives and unaccusatives cross-linguistically, in contrast with transitive constructions that have full or clitic objects. This fact has been taken to indicate that the anaphoric clitic bears the theta-role of the external argument, with the internal argument raising to subject position, as in a passive (Marantz 1984, Kayne 1986, Snyder 1992, Postma 1995). Examples illustrating the passive-like character of the anaphoric clitic/affix construction are given below.

1.1 Transitives with an anaphoric clitic

First, let us consider auxiliary selection in French and Italian. Perfect participles formed from a transitive verb are shown in (3). (3a), with a pronominal object clitic, takes the usual transitive auxiliary, *avoir*. On the other hand, when the same verb occurs with an anaphoric clitic argument, as in (3b), it takes the auxiliary *être*. The same auxiliary is used in the passive (3c). The use of this auxiliary has been taken to indicate that the anaphoric

construction has the syntax of the passive, with the object raising to subject position, as shown.

- (3) a. Pierre l' *est / a frappé.
 P. him is / has hit
 'Pierre hit him.'
- b. Pierre s' est / *a frappé t.
 P. REFL is / has hit
 'Pierre hit himself.'
- c. Pierre était / *avait frappé t.
 P. was / had hit
 'Pierre was hit.'

The same facts hold in Italian, where the *essere* 'be' auxiliary is also used consistently with unaccusatives (Burzio 1981), and not with unergatives. (4a) shows an Italian reflexive clitic construction, using *essere*. The non-clitic reflexive is a normal object, appearing with the usual transitive *avere* 'have' auxiliary, as in (4b).

- (4) a. Gianni si è esaminato.
 G. REFL is examined
 'Gianni has examined himself.'
- b. Gianni ha esaminato se stesso.
 G. has examined himself
 'Gianni has examined himself.'

Another difference between anaphoric clitics and objects can be seen in their behaviour in causative constructions. (5) shows a transitive clause embedded under a causative verb. In the usual case, as in (5a), the object is accusative, and the embedded subject shows up as a "dative" PP. However, when the embedded clause has an anaphoric clitic, as in (5b), the DP *le juge* has accusative Case. The same is true when the embedded clause has an intransitive verb, as in (5c).²

² (5a-b) are based on examples from Kayne (1975:407) with *tuer* 'kill' instead of *reveler* 'reveal.' Kayne's examples are ungrammatical for my French consultants. My thanks to Marie-Hélène Côté for careful discussion of these examples.

- (5) a. Jean le fait reveler *le / au juge.
 J. it makes reveal the / to-the judge
 'Jean is making the judge reveal it.'
- b. Jean fait se reveler le/*au juge.
 J. makes REFL reveal the / to-the judge
 'Jean is making the judge reveal himself.'
- c. J'ai fait partir Jean.
 I-have made leave J.
 'I made Jean leave.'

As Snyder (1992) points out, the descriptive generalization is that the causative verb and the embedded verb are together associated with only a single structural (accusative) Case feature. The argument that checks this Case is the object of a normal embedded transitive clause, or the subject of an intransitive clause. Unlike a normal transitive subject, the subject of the anaphoric clitic construction checks structural (accusative) Case when embedded under a causative verb. Under the story sketched above, the anaphoric clitic cannot check Case, so the object is the only argument available to check this Case feature.

Marantz (1984) proposes that the subject of these constructions moves from an object position, while the theta-role of the external argument goes to the anaphoric clitic. As Marantz points out, however, there is no obvious reason why an anaphoric clitic should be barred from object position. Pronouns and R-expressions are generated in object position, where their status as clitics or nonclitics is irrelevant to auxiliary choice and Case marking. Moreover, nonclitic anaphors can be generated in object position. Thus some explanation is needed for the fact that anaphoric clitics cannot behave syntactically like normal object clitics. The explanation I propose is that object clitics move into the checking domain occupied by the external argument. If the clitic is anaphoric, it must be bound, but cannot be bound by the external argument. Since no closer binder is available, the derivation crashes. In short, this construction is a subcase of the general case, ruled out in Chapter 3, in which an anaphor and its antecedent occupy specifiers of the same head.

Let us consider the derivation of a simple transitive construction with an object clitic. The object moves to check Case in a specifier of v , since the feature [clitic] pied-

pipes the whole clitic DP for Case-checking. In this position it is in the checking domain occupied by the external argument, so the two are subject to Lethal Ambiguity. If the clitic is an anaphor, the derivation is uninterpretable, since no anaphoric dependency can be established between the clitic and the only argument in a structural position to bind it, namely the subject.

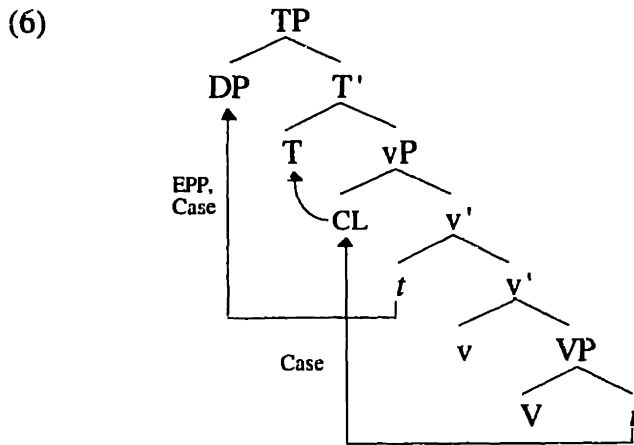

1.2 Indirect objects

Snyder (1992) shows that anaphoric indirect object clitics are also blocked. (7a) shows a transitive verb with an external argument and a dative indirect object clitic, whose participle takes the *avoir* 'have' auxiliary. The counterpart with an anaphoric clitic again requires the *être* 'be' auxiliary.

- (7) a. Jean lui a parlé t.
 J. 3SG.DAT has talked
 'Jean talked to him/her.'
- b. Jean s' est parlé t.
 J. REFL is talked
 'Jean talked to himself.'

Causatives based on such verbs also show a difference between their anaphoric and non-anaphoric counterparts. With the pronominal clitic, the causative construction is simply ungrammatical (8a). With the anaphoric clitic, on the other hand, the causative is only

slightly marginal (8b). Note that in this case the embedded subject *Marie* checks accusative case, as in the examples above with an anaphoric clitic and a direct object.

- (8) a. *Jean fait (à) Marie lui parler. / *Jean fait lui parler (à) Marie.
 J. makes (to) M. 3SG.DAT talk
 'Jean is making Marie talk to him/her.'
- b. ?Jean fait Marie se parler.
 J. makes M. REFL talk
 'Jean is making Marie talk to herself.'

Under the account presented here, an anaphoric indirect object clitic is blocked for the same reason as an anaphoric direct object clitic: it moves into the checking domain occupied by the external argument. The syntactic subject originates as a DP indirect object. Note that a nonclitic DP indirect object is impossible in an active construction (9a).

Moreover, an indirect object cannot become the subject of a passive (9b).

- (9) a. Jean parle *(à) Marie.
 J. talks to M.
 'Jean talks to Marie.'
- b. *Marie est parlé(e) *t*.
 M. is talked to
 'Marie is talked to.'

These examples contrast with the anaphoric clitic construction in (7b), where the indirect object is a DP, and does raise to the subject position. This difference can be attributed to the selectional properties of ν . We have already assumed that an anaphoric clitic is generated in the specifier of a special type of ν , which lacks any features that would attract a lower DP. Let us assume further that this ν selects as its complement an RP that does not have inherent Case. Meanwhile, the normal passive ν in (9) selects an RP that does have inherent Case.

A similar alternation can be seen in the active and passive versions of French *obéir* 'to obey' (Kayne 1984). The active ν selects an RP with inherent Case (10a), and the passive an RP without (10b).

- (10) a. Les enfants ont obéi *(à) Jean.
the children have obeyed to J.
‘The children obeyed Jean.’
- b. Jean a été obéi *t* par les enfants.
J. has been obeyed by the children
‘Jean was obeyed by the children.’

As we saw in (9), however, this alternation is not generally available in passives; the availability of this alternation with *obéir* shows that there is a dependency between the choice of R and the choice of V. An R that lacks an inherent Case feature can be combined with *obéir*, but not with *parler* ‘talk,’ for example.

Variations in the combinations of ν and R can also be observed in a double-object construction. In (11), the higher argument is the DP indirect object, which is the most local argument to the subject position.

- (11) a. Jean s’ est écrit *t* cette lettre.
J. REFL is written this.F letter
‘Jean wrote himself a letter.’
- b. Jean se l’ est écrite *t t*.
J. REFL it is written.F
‘Jean wrote it to himself.’

(Philippe Schlenker, p.c.)

Once again, ν lacks any features that would attract the indirect object, so this argument moves to the subject position without leapfrogging through the checking domain occupied by *se*. If ν had a Case feature to check, it would have to attract the indirect object, as the most local argument. The indirect object would then move to the specifier of ν P on its way to the subject position, with the result that it could not establish an anaphoric dependency with *se*. Moreover, having checked Case, it would be unable to move on and check the Case and EPP features of T. Instead, the direct object checks Case on R, while the indirect object checks Case on T. (12) shows the derivation of a double object construction with an anaphoric clitic.

(12)

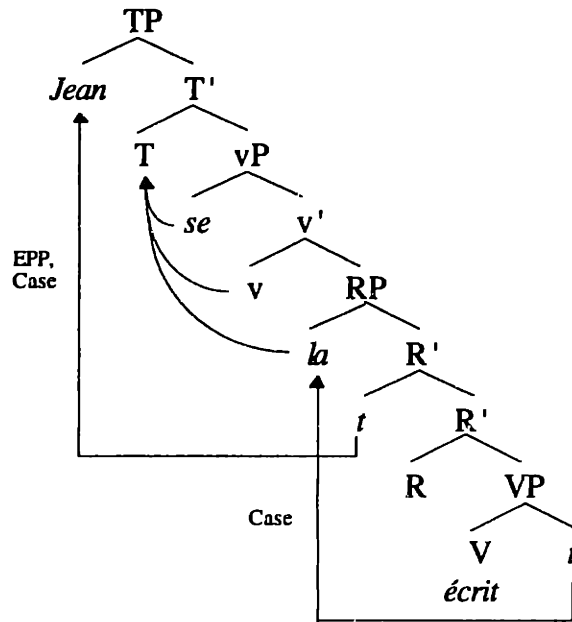

A PP indirect object originates below the direct object, so when the object is a PP, the direct object should be the most local argument for attraction to the subject position. Snyder (1992) reports that the direct object can also raise to the subject position of an anaphoric clitic construction (13).

(13) Jean s' est présenté t à Marie.

J. REFL is introduced to M.
'Jean introduced himself to Mary.'

Thus, either a direct or an indirect object can raise to the subject position of an anaphoric clitic construction. As we saw in Chapter 3, only a direct object can do so in the passive (except with *obéir*). This is because the inherent Case feature of R can be suppressed in the anaphoric clitic construction, but not in the passive. If the indirect object is in a PP, it cannot be attracted to check EPP. Moreover, the indirect object cannot raise to the subject position if it is a clitic, since once adjoined to T it cannot be attracted to a specifier of TP. Thus an indirect object can raise to the subject position only if it is generated as a DP. On the other hand, the opposite pattern can be observed for indirect object clitics, which are possible in the passive (14a) but not in the anaphoric clitic construction (14b).

- (14) a. Jean lui est présenté t t.
 J. 3SG.DAT is introduced
 'Jean is introduced to him/her.'
- b. *Jean se lui est présenté t t.
 J. REFL 3SG.DAT is introduced
 'Jean introduced himself to him/her.'

As noted in Chapter 3, there is a general restriction (the **me-lui* constraint) on the distribution of third-person dative pronouns. Assuming that *lui* cannot cooccur with *se* for morphological reasons, (14b) is appropriately ruled out.

The account sketched here has implications for the derivation of possessive anaphoric constructions like that in (15a). *Abrir* 'open' is a root that appears in both transitive and inchoative constructions. Lidz (1996) notes that the possessive interpretation is present in both (15a), which has an anaphoric clitic, and (15b), which lacks one. However, the two cases differ in other ways. (15a) can be modified by an instrumental phrase, as shown, while (15b) can only mean that Maria's eyes opened of their own accord, so no instrumental phrase is possible.

- (15) a. Maria se abrió los ojos (con las manos).
 M. REFL opens the eyes with the hands
 'Mary opened her eyes (with her hands).'
- b. Maria abrió los ojos (*con las manos).
 M. opens the eyes with the hands
 'Maria's eyes opened (*with her hands).'

A straightforward account of these facts can be made within the general approach taken here. Suppose that the anaphoric clitic in (15a) is in fact a non-DP external argument, generated in a specifier of *v*. The syntactic subject, *Maria*, originates as the possessor of the DP *los ojos*. Following the traditional analysis of "ethical datives," I will assume that this possessive construction has the same structure as the double object construction, with

the possessor generated in a specifier of RP, and the possessee within the VP projection.³ When T attracts an argument, the closest argument to it is the possessor, *Maria*. Thus the sentence in (15a) has an external argument coreferential with the possessor of the theme/object. The proposed structure for (15a) is shown in (16).

(16)

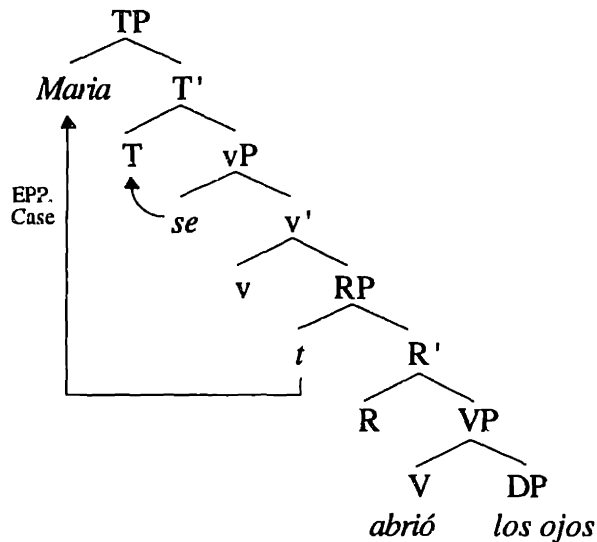

(16) differs in a couple of ways from its non-anaphoric counterpart in (17). In (16), *v* has no structural Case feature to check, and its specifier is filled by a non-DP argument, the anaphoric clitic. In (17), on the other hand, the possessor clitic checks structural dative Case in spec-*vP* before adjoining to T. The external argument here is *Maria*, which raises and checks Case in the spec-TP. In this derivation, both the external argument and the dative possessor clitic occupy specifiers of *vP*, a configuration subject to Lethal Ambiguity.

Thus this derivation is not available for (15a), where an anaphoric dependency obtains between the possessor and the external argument. In both derivations, however, the possessed object checks a Case feature on R.

- (17) *Maria le abrió los ojos (con las manos).*
 M. 3SG.DAT opens the eyes with the hands
 'Mary opened his eyes (with her hands).'

³ Landau (1998) argues that possessor-raising in Hebrew involves A-movement of the possessor from within the DP headed by the possessee. Such movement would raise problems for the theory of Case assumed in this thesis, in addition to the A-over-A principle (Chomsky 1964).

I attribute the possibility of using the instrumental phrase to the presence of an external argument. Since the action is externally caused, rather than arising from intrinsic properties of the theme, it can be mediated by an instrument. The fact that no instrumental phrase can be used in (15b) suggests that this construction also involves possessor-raising, this time from within an unaccusative *vP*, lacking an external argument (18).

(18)

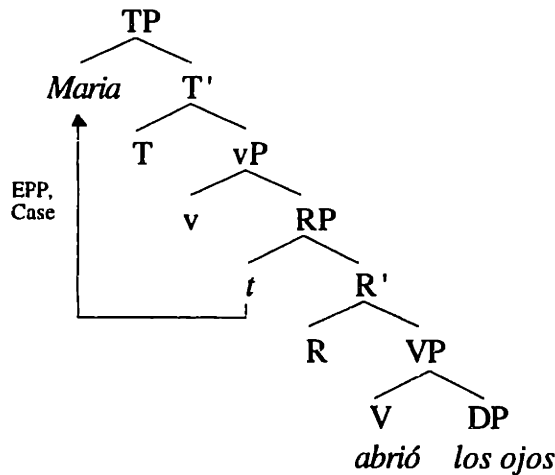

Like the *v* associated with the anaphoric construction, the unaccusative *v* lacks a Case feature. The possessor argument checks nominative Case in the specifier of TP. The absence of an external argument gives rise to the spontaneous interpretation of the event described by the verb phrase. Of course, the instrumental phrase is possible on another reading of this sentence, shown in (19), in which the subject is an external argument, rather than a possessor. For example, this sentence could be used to describe a situation where, for example, Maria sees a pair of fake eyeballs in a store and opens the lids with her hands.

- (19) *Maria abrió los ojos (con las manos).*
 M. opens the eyes with the hands
 'Maria opened the eyes (with her hands).'

We have seen evidence from French and Italian that an anaphoric clitic does not have the syntactic behaviour of either a pronominal object clitic or a nonclitic anaphor. My account of these facts is twofold: first, no well-formed derivation can result from generating an anaphoric clitic in the position of a normal object clitic. A clitic must be sufficiently local to T in order to adjoin to it. As a result, unless the clitic is itself closest to

T, it will always end up moving into the checking domain occupied by the argument closest to T—the argument that ends up raising to the subject position. No well-formed anaphoric dependency can obtain between these two arguments, since they move out of specifiers of the same head. If the clitic is an anaphor, then, it cannot be bound by the argument that becomes the syntactic subject. Since it also cannot be bound by any other argument, the derivation is uninterpretable.

1.3 *Anaphoric clitics and ECM verbs*

Further evidence for the unusual behaviour of anaphoric clitics can be found in a wide range of languages. It should be noted that the same analysis can apply to anaphoric elements spelled out as affixes, rather than clitics. I assume that this clitic/affix distinction is morphophonological, having no bearing on the syntax. For example, Icelandic has a suffix *-st*, used as a reflexive argument or to form the “middle” from a transitive verb. This suffix can be attached to an ECM verb to create a reflexive interpretation. Like Romance *se/si*, Icelandic *-st* can only be generated as the external argument (cf. Marantz 1984). Consider the examples in (20). In (20a) the subject of the embedded clause is the reflexive *sig*, which checks the Case feature on the matrix *v*. The adjectival predicate in the embedded clause agrees in m-case with its accusative subject. (20b) has (essentially) the same interpretation; here, however, the anaphor is not the subject of the embedded clause, but rather the external argument of the matrix clause. The subject of the embedded clause is the pronoun *hann*, which raises to become the subject of the matrix clause, checking Case on T. Here, since the subject of the embedded predicate is nominative, agreement on the predicate is also nominative. If *-st* were instead the subject of the embedded clause, it would have accusative m-case, triggering accusative agreement on the embedded predicate, as in (20a).

- (20) a. Hann telur [sig vera sterkan].
 He.NOM believes himself.ACC to be strong.ACC
 ‘He believes himself to be strong.’

b. Hann tel-st [t (vera) sterkur].

He.NOM believes-REFL to be strong.NOM

‘He believes himself to be strong.’

(Andrews 1982)

Under the account proposed here, *-st* is a non-DP specifier of the matrix *v*, which lacks any features that would attract the embedded subject *hann* into its specifier. Instead the embedded subject is attracted into a specifier of the matrix T, as shown in the derivation on the left in (21). From this position the subject can bind *-st*, so the derivation converges interpretably. The derivation for an ECM sentence with an anaphoric affix is thus much like the derivation of a raising construction. We can easily rule out the ill-formed structure in which *-st* is generated as the embedded subject, checking Case on the matrix *v*. Suppose that, like Romance clitics, a DP *-st* in Icelandic would have to check Case by moving into a specifier. If it checked Case in a specifier of the matrix *vP*, it would be in the checking domain occupied by the external argument, as shown in the derivation on the right in (21). The familiar Lethal Ambiguity effects would arise, yielding uninterpretability.

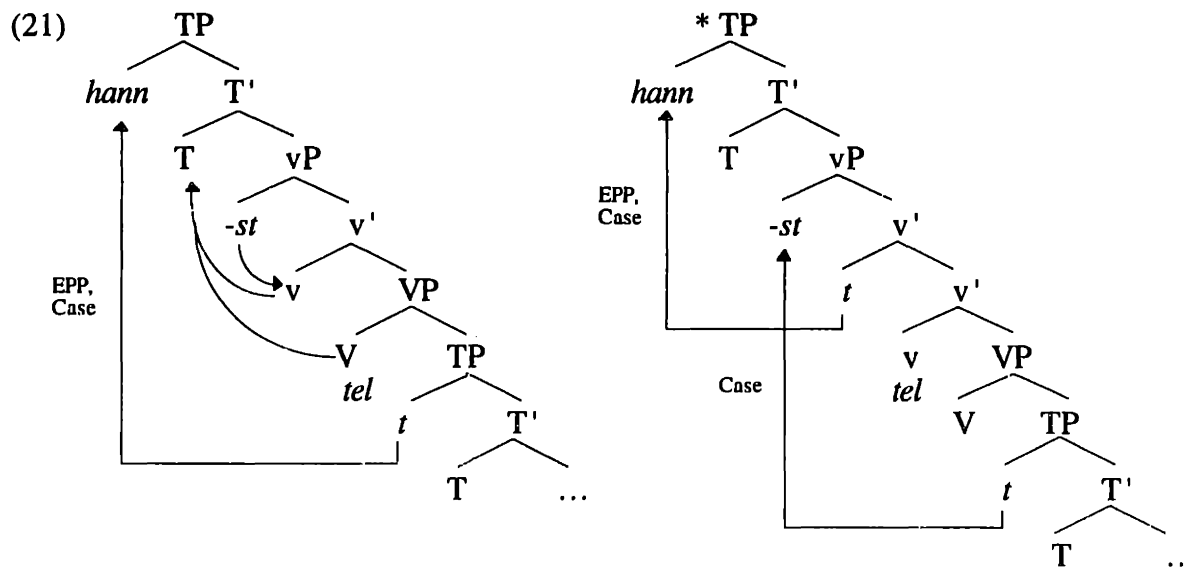

1.4 Arbitrary agents

Marantz (1984) offers another argument in favour of the view that an anaphoric clitic/affix construction involves a derivation similar to a passive: the two constructions often have the same morphology. For example, we have already noted that Icelandic *-st* has either an

anaphoric or a “middle” interpretation, with an arbitrary, unspecified (ARB) agent. The *se/si* clitic of Romance languages also allows either interpretation, as is well known (e.g. Grimshaw 1982, Cinque 1988, Dobrovie-Sorin 1998). Marantz notes that the same is true in a number of languages, including Central Arctic Eskimo, Dyirbal (Dixon 1972), and Lardil (Klokeid 1976).

Georgian has an affix that allows an anaphoric or ARB interpretation as well (Nash 1995:322). A verbal prefix *i-* contributes the anaphoric interpretation in (22b), while in (23b) it contributes an ARB interpretation for the external argument.

- (22) a. Vano ban-s xeleb-s.
V.-NOM wash-PRES hands-ACC
'Vano is washing the hands.'
- b. Vano i-ban-s xeleb-s.
V.-NOM REFL-wash-PRES hands-ACC
'Vano is washing his hands.'
- (23) a. Vano-m da-cer-a roman-i.
V.-ERG PREV-write-AOR novel-NOM
'Vano wrote a novel.'
- b. Romani da-i-cera.
novel-NOM PREV-ARB-write-AOR
'The novel was written.'

Under the account sketched here, in both cases *i-* is a categorially underspecified external argument generated in the specifier of ν P and not checking Case. The widespread conflation between ARB and anaphoric morphology is consistent with the account given here, where the two types of arguments share formal properties.

The Romanian example in (24a) also has a passive-like derivation, again with an ARB interpretation for *se*. Romanian is a *pro*-drop language; in (24a) a null third-person plural object checks (nominative) Case on T, triggering agreement on the auxiliary. Dobrovie-Sorin (to appear) argues that nominative *pro* can also be interpreted as the prototypical object of a verb like 'eat,' as in (24b), where the object is not understood as referring to a particular food or dish. It has been argued that unergative verbs like 'sleep'

have a cognate object (Hale & Keyser 1993a, Bobaljik 1993); Dobrovie-Sorin proposes that this cognate object can be structurally realized as nominative *pro*.

- (24) a. S-au mîncat *pro* ieri.
 ARB-have eaten they yesterday
 ‘They were eaten yesterday.’
- b. S-a mîncat *pro* bine ieri.
 ARB-has eaten (food) well yesterday
 ‘We/they ate well yesterday.’
- c. Se doarme *pro* bine aici.
 ARB sleeps (sleep) well here
 ‘One sleeps well here.’

Non-DP ARB, on the other hand, is always generated in the specifier of *v*. Thus unaccusatives and passives with ARB are impossible in Romanian. For example, the passive in (25a) is not compatible with ARB *se*. Similar facts also exist in other Romance languages, such as Italian; in Italian, however, the situation is slightly more complicated, since *se/si* can also be nominative in Italian. Unlike non-DP *se/si*, nominative *se/si* can be generated in any theta-position, provided it can check nominative Case. As a result, Italian, unlike Romanian, allows unaccusatives and passives with *se/si* (25b). Thus to observe the similar behaviour of non-DP *se/si* in Italian and Romanian, it is necessary to disentangle Italian non-DP *si* from nominative *si*.

- (25) a. * Adesea se este trãdat de prieteni falși.
 frequently ARB is betrayed by false friends
 ‘One is frequently betrayed by false friends.’
- b. Spesso si è traditi dai falsi amici.
 frequently ARB is betrayed by false friends
 ‘One is frequently betrayed by false friends.’

The possibility of having nominative *se/si* can be attributed to the possibility of cliticizing to C instead of to T (Barbosa 1995). A nominative clitic in Italian checks Case in spec-TP before cliticizing to C. In Romanian, *se* can only cliticize to T; under the assumption that

Case is checked in a spec-head configuration, the clitic cannot check nominative Case on T.⁴

Dobrovie-Sorin argues that Italian also has non-nominative (here, non-DP) *si*, and that only this variant of *si* can remain within a nonfinite embedded clauses. (26) shows raising constructions with embedded *si*. Only nominative *si* can be used in a passive or unaccusative, since these lack an external argument. As we have assumed throughout, a clitic must raise overtly to check Case. As long as *si* raises into the finite clause, it can check nominative Case, yielding a well-formed structure (26a). If *si* fails to raise into the finite clause, it cannot check nominative Case. The well-formedness of such constructions then depends on whether non-DP *si* is possible. If the embedded clause is passive or unaccusative, as in (26b), non-DP *si* is ruled out, so the derivation crashes. On the other hand, if the embedded clause has an external argument, as in (26c), non-DP *si* is possible.⁵ Here the structural subject of the embedded clause is the postverbal argument *poche automobili*.⁶ Features of this argument are attracted to the finite T, triggering agreement on the matrix verb (examples based on Cinque 1988).

- (26) a. Spesso si sembra [t non essere stati invitati da nessuno].
 often ARB seems NEG be invited by anyone
 ‘One often seems not to have been invited by anyone.’
- b. *Sembra [non esser-si stati invitati da nessuno].
 seems NEG be-ARB invited by anyone
 ‘One seems not to have been invited by anyone.’
- c. Sembrano [esser-si venduto poche automobili].
 seems.PL be-ARB sold few cars
 ‘Few cars seem to have been sold.’

⁴ The distribution of ARB is restricted to certain structural positions cross-linguistically (cf. Chomsky 1986, Cinque 1988, Mendikoetxea 1992, among others); for example, it cannot occur as the object of a transitive clause. These universal restrictions are not my concern here.

⁵ Non-DP *si* is also possible in Italian unergatives, just as in the Romanian (24c).

⁶ The postverbal argument in (26c) may be more accurately viewed as the associate of a null expletive in the position of structural subject. This distinction makes no difference to the discussion here.

Both nominative and non-DP *si* are possible in Italian finite clauses. When *si* is not a DP, the logical object checks the nominative Case feature of T, triggering subject agreement on the verb (27a). When *si* is nominative, it checks the Case feature of T, so T does not agree with the logical object (27b).

- (27) a. Si mangiano le mele.
 ARB eat.PL the apples
 'The apples are eaten.'
- b. Si mangia le mele.
 ARB eat the apples
 'One eats the apples.'

Thus Italian, like Romanian, has non-DP ARB *si*. My account of movement in cases with non-DP ARB *si* is identical to the account of the anaphoric clitic/affix construction. To recap, a lower argument can raise past a higher one under two conditions: the lower argument leapfrogs through the checking domain occupied by the higher one, or the higher argument is not a DP, so it is ignored for the purposes of attraction to T. In the last chapter, it was shown that an argument cannot form an anaphoric dependency with another argument that occupies a multiple-specifier configuration with it. If the anaphor is not a DP, a lower argument can raise past it to the subject position without leapfrogging through the same checking domain. As a result, a derived subject can bind an anaphoric clitic/affix in spec-*vP*.

This derivation is unusual, however; it is not generally the case that an object can move past the logical subject to the structural subject position. Even in languages with an anaphoric clitic, a pronominal clitic must be generated as a DP. As a result, a pronominal clitic cannot be associated with the derivation involving movement of the object to the subject position, as in (28b).

- (28) a. Isabelle nous parle *t*.
 I. IPL speaks
 'Isabelle is speaking to us.'

- b. *Isabelle nous parle *t*.
 I. 1PL speaks
 ‘We are speaking to Isabelle.’

However, a derivation like that of (28b) is possible if the non-DP clitic/affix is anaphoric or ARB. Since anaphoric and ARB elements can be distinguished from pronouns and R-expressions by a semantic property (referential underspecification), it seems plausible to give exactly the same account for the derivation of the anaphoric clitic/affix construction and the non-nominative ARB construction. The interpretation of the anaphor depends on its antecedent, while the interpretation of ARB remains unspecified.

In previous sections we have seen evidence against the existence of a derivation in which an anaphoric clitic/affix occupies the checking domain occupied by another argument. The ill-formedness of such derivations has been attributed to Lethal Ambiguity. For the correct derivation, we have proposed that the anaphoric clitic/affix is generated as a non-DP argument in a specifier of ν P. This proposal accounts for the evidence that the structural subject of such constructions has moved from an object position. Note, however, that our theory would in principle allow the reflexive clitic/affix to be generated in object position, provided that it was not required to check Case on a head. (29a) suggests that such a derivation is impossible. This example would be grammatical if non-DP ARB *si* could be generated in a specifier of ν , and non-DP anaphoric *si* (*ci*) in a specifier of R. The theme (*i due bimbi*) would then raise past both non-DP arguments, checking the nominative Case feature on T. As we have seen, a ν with a non-DP argument in its specifier has no features to attract a DP; assuming that the same would be true for R, there would be no need for the theme to move through a specifier of either RP or ν P, and the derivation would be well-formed.

- (29) a. *I due bimbi ci si affideranno *t* *t*.
 the two children RECIP ARB will entrust
 ‘The two children will be entrusted to each other.’

I propose that the intrinsic properties of the anaphoric clitic/affix do not prevent it from being generated as a DP, any more than the intrinsic properties of the ARB clitic/affix do. Rather, through a combination of factors, a DP anaphoric clitic/affix will always yield an uninterpretable derivation. Only derivations with its non-DP counterpart will be well-formed.

1.5 *C-command and binding*

Lidz (1996) notes that not all languages with an anaphoric clitic/affix construction use the same morphology for the arbitrary interpretation of the external argument. However, he claims that all languages with an anaphoric clitic/affix also use this affix for anticausatives. I use the term “anticausative” for an unaccusative verb formed via the addition of morphology to the root of a verb otherwise used in the transitive construction. For example, consider the French examples in (31). We have already seen that *se* has an anaphoric interpretation in French. (31a) is an “intrinsically” unaccusative verb with *se*, having no transitive counterpart, while (31b) is an anticausative version of transitive *briser* ‘break.’

- (31) a. Il s'évanouit.
he vanishes
'He vanishes.'
- b. Le verre se brisera.
the glass UNACC break.FUT
'The glass will break.'

Under the approach taken here, the use of the same morphology for the anticausative and anaphoric clitic/affix construction can be attributed to the intrinsic featural underspecification of the item used to spell out the anaphoric element. Bonet (1991) argues that Catalan *se* is a “default” morphological item, spelling out any pronominal clitic not spelled out by a more highly specified item. Even in languages where the anaphoric clitic/affix has a more restricted distribution, Embick (1997) argues that *se/si* is sufficiently underspecified to spell out a morphological clitic without any nominal features. In the

anticausative construction, this item spells out a clitic associated with the nonactive *v* of the anticausative. The cross-linguistic connection between these two constructions thus arises from the underspecification of the morphological exponent. This underspecification is not subject to variation, because the syntactic element spelled out is itself semantically underspecified.

Some authors (Grimshaw 1982, Lidz 1996) have taken the morphological conflation between the anaphoric and anticausative clitic/affix to indicate that the two are syntactically identical. However, there is evidence against such a view. Reinhart (1996) notes a case in Hebrew where the anaphoric clitic/affix construction patterns separately from unaccusatives with the same morphology. These examples illustrate the fact that reflexive clitic/affix constructions are subject to structural requirements on binding. In particular, the (trace of the) anaphoric clitic/affix in spec-*vP* must be c-commanded by its antecedent, while there is no such requirement in an unaccusative.

Let us consider the Hebrew cases where this distinction surfaces. An anaphor can surface as part of the templatic verb morphology (*binyan*) in the so-called *hitpa'el* form. This form can be used for “inherent” reflexives, as in (32a), or for unaccusatives, as in (32b).

- | | | | | | | |
|------|----|-----------|---------|----|-----------|------------|
| (31) | a. | hitraxec | ‘wash’ | b. | hitgalgel | ‘roll’ |
| | | hitlabesh | ‘dress’ | | hitmotet | ‘collapse’ |
| | | hitgaleax | ‘shave’ | | hitalef | ‘faint’ |
| | | histarek | ‘comb’ | | hitkamet | ‘wrinkle’ |

Hebrew is a pro-drop language, so the subject position need not be filled by an overt argument. The internal argument of an unaccusative can be left in its post-verbal position (33a), with its features raising covertly to check Case on T. However, the internal argument of the anaphoric *hitpa'el* construction cannot remain in a post-verbal position (33b). My Hebrew examples are from Reinhart (1996), Danny Fox (p.c.) and Idan Landau (p.c.).

- (33) a. Ani xoshev she hitalef mishehu.
I think that fainted someone
'I think that someone fainted.'
- b. *Ani xoshev she hitraxec mishehu.
I think that washed.REFL someone
'I think that someone washed (themselves).'

The contrast in (33) follows from the fact that an anaphor is present in (33b), but not in (33a). In (33b), the anaphoric element *inspec-vP* must be c-commanded by its antecedent, the internal argument. On the assumption that attraction to check the Case feature of T is necessary to establish subject-verb agreement, (34a) shows that features of the postverbal subject are attracted to T, triggering agreement on the verb. However, these features cannot bind the anaphor in *spec-vP*. Even when the verb shows agreement with the postverbal subject, binding is ill-formed (34b).

- (34) a. Ani xoshev she T^0 hitalfu [harbe ?anashim].
I think that fainted.PL many people
'I think that many people fainted.'
- b. *Ani xoshev she T^0 hitraxcu [harbe ?anashim].
I think that washed.PL many people
'I think that many people washed (themselves).'

For binding to take place, the subject cannot be left in postverbal position; it must undergo phrasal movement to the subject position, as in (35). On the other hand, no anaphoric binding is required in the unaccusative (33a), so there is no need to raise the post-verbal argument to the subject position.

- (35) a. Ani xoshev she mishehu hitraxec.
I think that someone washed.REFL
'I think that someone washed (themselves).'
- b. Ani xoshev she harbe ?anashim hitraxcu.
I think that many people washed.REFL.PL
'I think that many people washed (themselves).'

Other languages also show instances of anaphors that cannot be bound by phi-features attracted for Case. In an English expletive construction with *there*, for example, the phi-features of the indefinite "associate" raise to check Case on the T node with the

expletive specifier. These features trigger agreement on the verb, but cannot bind an anaphor, as shown in (36a). On the other hand, the same argument can bind the anaphor if it undergoes phrasal movement to the matrix subject position, as in (36b).

- (36) a. * There seem to each other [*t* to be many men in Menomonie].
 b. Many men seem to each other [*t* to be *t* in Menomonie].

These examples provide additional evidence that phi-feature attraction to check Case does not create the necessary configuration for binding the anaphor.

A similar situation arises in Icelandic. As we saw in Chapter 2, the dative subject of an embedded clause can raise to a matrix subject position in Icelandic. The raising verb can then agree with a nominative object in the embedded clause, whose Case and phi-features are attracted to check the Case feature of T (37).

- (37) Jóni vera taldir [*t* líka frúr]].
 J.DAT be considered like ladies.NOM
 ‘John seems to like ladies.’

Recall that an ECM construction with an anaphoric affix has a derivation similar to that of a raising construction. The anaphor in spec-*v*P can be bound by a nominative derived subject, as we saw in (20). However, the *-st* anaphor—unlike other anaphors in Icelandic—cannot be bound by a dative subject, as shown in (38a). When the subject is dative, the only possible use of *-st* is the “middle” use, with an arbitrary interpretation for the external argument (38b). As in (37), the phi-features of the nominative object are attracted to check the Case feature of T, triggering agreement on the verb. If these features could bind anaphoric *-st* in spec-*v*P, it would be possible for the external argument of the matrix verb (i.e., *-st*) to corefer with the nominative object of the embedded clause. This interpretation is impossible, as shown in (38c).

- (38) Jóni tel-st [*t* líka frúr]].
 J.DAT believe-ARB like ladies.NOM
 a. * ‘John believes himself to like ladies.’
 b. ‘John is believed to like ladies.’

- c. * 'Ladies_i believe John to like them_i.'

Again, we see that features raised for Case cannot bind the anaphor. Returning to Hebrew, a postverbal subject cannot bind the anaphor in spec-*vP* in the anaphoric *hitpa'el* construction. Binding is possible only if the antecedent undergoes phrasal movement to a position where it c-commands the anaphor.

It has been claimed that postverbal subjects in French can bind anaphoric *se*, as in (39) (from Kayne 1975:381). My consultants find a great deal of variability in examples of this kind, but (39) is fairly acceptable. Note that the matrix auxiliary shows no agreement with the plural associate, suggesting that T does not attract the phi-features of the associate. Nevertheless, some relation exists between the expletive and the associate, since the associate is necessarily indefinite and interpreted with presentational focus. Moreover, this relation is constrained by locality: the associate is always the would-be subject, the most local argument to the expletive in T. It is therefore plausible to assume that features of the expletive move to T in (39), where they can bind the anaphor in spec-*vP*.

- (39) ? Il s' est dénoncé trois milles hommes ce mois-ci.
 it.NOM REFL is denounced three thousand men this month-here
 'Three thousand men denounced themselves this month.'

Reinhart (1996) adopts a different view of the ungrammaticality of postverbal subjects with anaphoric *hitpa'el*. She takes these cases as evidence that the reflexive clitic/affix construction is formally unergative. Unergatives in Hebrew also disallow postverbal subjects, given neutral focus (cf. Sherman 1997). The ungrammatical (39a) shows an unergative verb with a postverbal subject; if the subject is preverbal, as in (39b), the example is perfect.

- (40) a. * Ani xoshev she rac mishehu.
 I think that ran someone
 'I think that someone fainted.'
- b. Ani xoshev she mishehu rac.
 I think that someone ran
 'I think that someone fainted.'

(Idan Landau, p.c.)

However, as we have seen, the anaphoric clitic/affix construction patterns cross-linguistically with unaccusatives and passives, not with unergatives. For example, the expletive construction discussed above is possible with unaccusatives (41a) and passives (41b), but not with unergatives (41c).

- (41) a. Il restait un problème important que...
 there remained a problem important that
 'An important problem which... remained.' (Martin 1970:381)
- b. Il a été mangé beaucoup de pommes hier soir.
 there have been eaten many of apples yesterday evening
 'Many apples were eaten last night.' (Kayne 1975:245)
- c. * Il a parlé beaucoup de ministres hier soir.
 there have spoken many of ministers yesterday evening
 'Many ministers spoke last night.' (Philippe Schlenker, p.c.)

Thus I conclude that the ill-formedness of postverbal subjects in the anaphoric *hitpael* construction in Hebrew arises, not because the construction is unergative, but because the postverbal subject cannot bind the anaphor in spec-*vP*, even though its features raise to check the Case feature of T. In some cases, an anaphoric clitic/affix *can* be bound by a lower argument whose features raise to T, suggesting that the features attracted are subject to parametric variation. As we have seen, such binding is impossible in several cases other than the anaphoric *hitpael* construction. In any case, the Hebrew facts make it impossible to maintain the view that unaccusatives and anaphoric clitic/affix constructions are syntactically identical, while the French facts make it impossible to maintain the view that unergatives and anaphoric clitic/affix constructions are syntactically identical.

In this section I have argued that relativized locality applies normally in ARB and anaphoric clitic/affix constructions. A lower argument can move past an anaphoric clitic in the specifier of *vP* without Lethal Ambiguity effects arising. I have proposed that this movement is possible because the anaphoric clitic/affix is not a DP and need not check Case. As a result, the clitic can simply adjoin to T, such that neither it nor its trace constitutes a locality barrier for A-movement of a lower DP argument. There is no Lethal Ambiguity effect because the lower argument is able to raise past the clitic (trace) without

moving into the same checking domain. I also stipulated that a non-DP argument can only be generated in the specifier of ν P. If the anaphoric clitic/affix is generated in the position of a pronominal object clitic, it must be generated as a DP, with the ability to check Case. Under these circumstances, locality and Case-checking requirements will inevitably give rise to Lethal Ambiguity effects, so that the anaphor cannot be properly interpreted at LF.

In the next section, we will consider another instance of a non-DP argument: the experiencer in an English raising construction. As in this section, the non-DP argument allows a lower argument to raise past it and establish an anaphoric relation with it. What is noteworthy about the English examples is that they suggest that Lethal Ambiguity effects are absent with argument types other than anaphoric clitics or affixes. Most accounts of the anaphoric clitic/affix construction depend solely on the morphosyntactic nature of the clitic/affix. This factor does play a role in the current account, since only featurally underspecified clitic/affix elements can be generated as non-DP external arguments in spec- ν P. However, other non-DP arguments can occur in other positions, as we will see below.

2 Raising in English

Raising constructions with an experiencer in English share certain locality properties with the anaphoric clitic/affix construction. An experiencer in the matrix clause does not block movement of the embedded subject to the matrix subject position, as shown in (42).

- (42) a. Greg struck me [*t* as having been quite fortunate].
 b. Gayle seemed to me [*t* to have been quite fortunate].

These examples contrast with their counterparts from Icelandic, Greek and Romance, discussed in previous chapters. In Icelandic, the dative DP experiencer itself raises to the subject position of the matrix clause (43a). In Greek and the Romance languages, a matrix DP experiencer blocks movement by the embedded subject. (43b) shows the example from Greek.

- (43) a. $\overbrace{\text{Mér virðist } t}$ [Haraldur hafa gert þetta vel].
 me.DAT seems H.NOM to have done this well
 ‘Harald seems to me to have done that well.’
- b. ?* $\overbrace{\text{O Jannis fenete tis Marias } [t]}$ eksipnos].
 the J.NOM seems the M.DAT intelligent
 ‘John seems to Mary intelligent.’

We also saw that in some cases, when the experiencer is a clitic or clitic-doubled, the lower argument can move past it by first moving into the same checking domain, as shown for Italian in (44a). As a result, no anaphoric dependency can be established between the two arguments; the raised subject cannot bind the experiencer (44b).

- (44) a. $\overbrace{\text{Gianni le sembra } t [t]}$ fare il suo dovere].
 G. her.DAT seems to do his duty
 ‘Gianni seems to her to do his duty.’
- b. * $\overbrace{\text{Gianni si sembra } t [t]}$ fare il suo dovere].
 G. REFL seems to do his duty
 ‘Gianni seems to himself to do his duty.’

In English, on the other hand, raising past an experiencer is fine, as we saw above.

Moreover, the raised subject can bind the experiencer, as shown in (45).

- (45) a. $\overbrace{\text{Greg struck himself } [t]}$ as having been quite fortunate].
- b. $\overbrace{\text{Gayle seemed to herself } [t]}$ to have been quite fortunate].

What I propose for these examples is that in both cases the experiencer is in a “cascade” PP. The PP node of a cascade PP is disregarded for the purpose of c-command (Pesetsky 1995, Phillips 1996). Because it is embedded in a PP, however, the experiencer is not attracted by T, so the embedded subject can raise past it without leapfrogging through the same checking domain. The result is that no Lethal Ambiguity effects obtain, and binding is permitted.

(46)

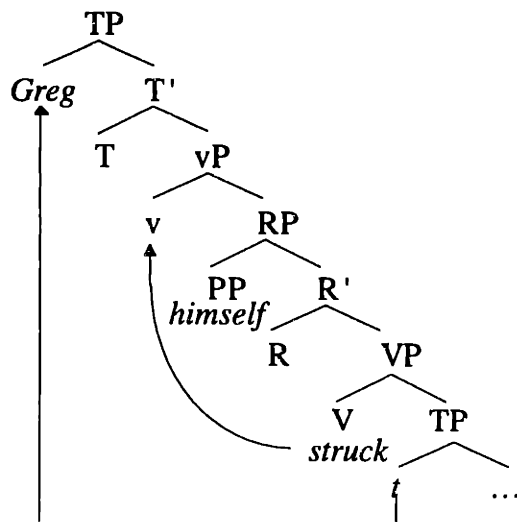

I propose that the experiencer is a PP simply for concreteness. Certainly no overt preposition appears with the experiencer of *strike*. The crucial point is that the experiencer lacks the features required for attraction to T. On the assumption that all DPs have such features, the experiencer is not a DP. Since the experiencer is accompanied by a preposition with *seem*, the most straightforward proposal is that it is in a PP, with a null preposition in the case of *strike*.

Examples of this kind are also discussed by Rizzi (1986). Rizzi argues that the configuration in (47) cannot yield an interpretable chain, where X, Y and *e* constitute a sequence of c-commanding elements and X binds Y.

(47) $X_i \dots \underbrace{[\alpha \dots Y_i \dots e_i \dots]}$

In §1 I argued that well-formed constructions with an anaphoric clitic/affix form a configuration of this kind. In the structure I proposed, Y_i would be the (trace of the)

anaphoric clitic/affix in the specifier of vP (α), and X_i would be the derived subject, which moves from an object position (e_i) to the specifier of TP. Because of cases of this kind, I have proposed a looser condition on interpretability of chains, whereby configurations like (47) are acceptable provided that X_i (or its trace) is not in the checking domain occupied by Y_i . Cases like (45) also pose a problem for Rizzi's proposed chain condition. Rizzi (1986) argues that the experiencer does not c-command the embedded clause in (45), and

moreover that *strike* does not involve raising at all. However, there is considerable empirical evidence against this argument, which we will consider in the following sections.

2.1 *The experiencer c-commands the embedded clause*

A number of tests show that the experiencer in a *seem*-construction c-commands arguments in the embedded clause. As noted by Pesetsky (1995:105), coreference between the experiencer and an R-expression in the embedded clause induces a condition C violation (48a). Moreover, an experiencer quantifier can bind a pronoun in the embedded clause, as in (48b-c). The same facts hold with *strike* (48).⁸

- (48) a. * Mary seemed to him_i [t to like John_i].
 b. Mary seemed to every boy [t to like him].
 c. Mary seemed to no one [t to like him very much].
- (49) a. * The agent struck him_i [as t more intelligent than Bond_i].
 b. The agent struck every conspirator [as t more intelligent than him].
 c. The agent struck no conspirator [as t more intelligent than him].

Rizzi (1986) also uses parasitic gaps to argue that the experiencer in a *strike* construction does not c-command into the embedded clause. His argument is based on the observation that *wh*-movement licenses a parasitic gap in a position c-commanded by the moved *wh*-phrase, but neither c-commanding, nor c-commanded by, the trace of the *wh*-phrase. A canonical example is shown in (50a).⁹ The *wh*-trace in (50a) is embedded in the

⁸ Rizzi (1986) reports a weak crossover effect in examples like (49b). However, none of my ten English consultants found a contrast between these examples and those with simple coreference, such as *The agent struck Bond as more intelligent than him*.

⁹ The same test unfortunately cannot be conducted for *seem* constructions. It is true that raising the experiencer PP does not licence parasitic gaps (i), but *to whom* appears not to licence parasitic gaps in general (ii). Raising *who* alone out of a *to*-PP does license parasitic gaps (iii), but *who* alone cannot be extracted from the experiencer PP of a *seem*-clause (iv).

- (i) **To whom** did the reporter seem *pg* [t to be speaking *t /??to him]?
- (ii) **To whom** did a letter *pg* apologize *t / *to him?
- (iii) **Who** did a letter to *pg* apologize to t / *him?
- (iv) ?* **Who** did the reporter seem to t [t to be speaking to Mary]?

main VP, and the parasitic gap in the participial adjunct, such that neither c-commands the other. Notice that a pronoun cannot be substituted for the parasitic gap (50b).

- (50) a. What did you [file _i *t*] [without reading *pg*]?
 └──────────────────────────────────┘
 b. *? What_i did you [file _i *t*] [without reading it_i]?
 └──────────────────────────────────┘

Engdahl (1983) shows that there is an anti-c-command requirement on parasitic gaps. If a gap is c-commanded by the trace of the *wh*-phrase, the structure is ill-formed, as in (51a). In this configuration, a pronoun can be used instead of a parasitic gap.

- (51) a. * Which Caesar did Cleopatra say [_i *t* was impressed by her singing to *pg*]?
 └──────────────────────────────────┘
 b. Which Caesar did Cleopatra say [_i *t* was impressed by her singing to him]?
 └──────────────────────────────────┘

Thus parasitic gaps can be used to diagnose c-command. If *wh*-moving the experiencer of a raising construction licenses a parasitic gap within the embedded clause, we can conclude that the experiencer does not c-command into the embedded clause. In fact, however, a parasitic gap is impossible in this environment (52a). Substituting a pronoun for the parasitic gap greatly improves the construction (52b). The contrast here patterns like the cases with c-command in (51), rather than the cases without c-command in (50).

- (52) a. * Who did the pamphlet strike _i [as *t* being insulting to *pg*]?
 └──────────────────────────────────┘
 b. ? Who did the pamphlet strike _i [as *t* being insulting to him]?
 └──────────────────────────────────┘

Rizzi (1986) claims that (52a) is grammatical. Looking at the contrast between (52a) and (52b), however, my consultants found a strong preference for (52b).¹⁰

There is therefore considerable evidence that the experiencer c-commands into the embedded clause. Nevertheless, I maintain the view that the experiencer itself is embedded within a PP. It has already been observed in the literature that DP can c-command out of a PP in certain cases (cf. Reinhart 1981, 1983, Jackendoff 1990, Pesetsky 1995, Phillips 1996). The examples in (53) show a DP binding an anaphor from within a PP (Pesetsky 1995:172).

¹⁰ Several consultants also volunteered the judgement that (52a) is completely uninterpretable.

- (53) a. Sue spoke [_{PP} to these people_i] about each other's_i friends in Bill's house.
 b. John spoke to Mary [_{PP} about these people_i] in each other's_i houses.
 c. Sue gave books [_{PP} to these people_i] on each other's_i birthdays_i.

In fact, this c-command relation appears to be obligatory. Coreference between a pronoun in the PP and a lower R-expression gives rise to Condition C effects, as shown in (54).

- (54) a. * Sue spoke [_{PP} to him_i] about Bill's_i friends.
 b. * John spoke to Mary [_{PP} about them_i] in these people's_i houses.
 c. * Sue gave books [_{PP} to them_i] on John and Mary's_i birthdays_i.

Van Riemsdijk & Williams (1986) suggest that a DP can c-command out of a PP because in some cases a preposition can be "reanalyzed" as part of the verb. Reanalysis has been proposed throughout the literature as the mechanism permitting A-movement out of PP, yielding a pseudopassive, as in (55a). Van Riemsdijk & Williams propose that the same mechanism is responsible for the fact that *Bill* can bind an anaphor outside its PP in (58b).

- (55) a. Bill_i was talked [_{PP} to t_i] about himself_i by John.
 b. John talked [_{PP} to Bill_i] about himself_i.

However, movement of the experiencer out of its PP is impossible for both *seem* and *strike* (56). It should be noted that the ill-formedness of (56) does not arise from leaving the subject within the finite clause. As shown in (57), the experiencer cannot raise even if the embedded subject is PRO. Note that the failure of the experiencer PP to allow pseudopassivization does not set it apart from other cascade PPs. Baltin & Postal (1996) point out other failures in the correlation between c-command out of a PP and pseudopassivization, such as in (58).¹¹

- (56) a. * Every boy_i seemed [_{PP} to t_i] [Mary to like him_i].
 b. * Every conspirator_i struck [_{PP} \emptyset t_i] [as the agent more intelligent than him_i].
 (57) a. * Gayle seemed [_{PP} to t_i] [that she was quite fortunate].
 b. * Each boy was suggested [_{PP} to t_i] [PRO to comb his hair].

¹¹ In fact, Baltin & Postal show that there is no coherent theory of reanalysis. Since they fail to propose one, however, I will continue to use the term "reanalysis" to wave at whatever relation or operation makes it possible for a DP to undergo A-movement out of a PP.

- (58) a. Marsha argued/fought/talked [_{PP} with Ludwig_i] about himself_i.
 b. * Ludwig_i was argued/fought/talked [_{PP} with *t*] about himself_i.

Thus, although the PP node may be ignored for purposes of binding, it cannot be ignored for purposes of movement. The experiencer is ineligible for movement, presumably because reanalysis has not applied to the PP. The PP itself is also ineligible for EPP-attraction, so the subject of the embedded clause can raise past it to the subject position without leapfrogging through the same checking domain. If the embedded subject were required to move through the same checking domain, we would expect Lethal Ambiguity effects to arise, since the PP node is ignored for purposes of binding. Pesetsky (p.c.) has pointed out evidence that cascade PPs in English are subject to Lethal Ambiguity effects. In some cases, although two PPs can in general be freely reordered, only one order yields a well-formed anaphoric dependency (Reinhart 1983, Jackendoff 1990, Larson 1990). This asymmetry suggests that the (a) examples below are in their base order, while the order in the (b) examples is derived.

- (59) a. I spoke [_{PP} with Rosa] about herself.
 b. * I spoke [_{PP} about Rosa] with herself. (Reinhart 1983)
- (60) a. John talked [_{PP} to the men] about each other.
 b. * John talked [_{PP} about the men] to each other. (Larson 1990)

Pesetsky (1995:271) notes that the first PP can in fact bind an anaphor in the second PP, as long as the anaphor is not itself the DP object of the preposition, but instead is embedded in this DP:

- (61) John talked [_{PP} about the men] (on Tuesday) with each other's supervisors.

This is exactly the pattern we have observed for Lethal Ambiguity effects. If we assume that the derived order involves movement of the lower PP to (or through) the checking domain occupied by the higher PP, then the ill-formed binding in the (b) examples can be attributed to Lethal Ambiguity effects like those discussed in the last chapter. These cases support the view that the embedded subject in an English raising construction is attracted past the PP experiencer without leapfrogging through the same checking domain.

As noted above, the DP experiencer cannot be attracted out of its PP. There are at least two kinds of PP from which movement is impossible—cascade PPs like those considered above, which enter into binding relations, and other PPs, which do not. In (62), although the DP cannot raise out of its PP, it can bind an anaphor and trigger condition C effects. In (63), however, condition C does not arise, and binding is comparatively ill-formed (examples based on Reinhart 1983).

- (62) a. * Ben was talked [with *t*].
- b. I talked [with Ben_{*i*}] about himself_{*i*}.
- c. * I talked [with him_{*i*}] in Ben_{*i*}'s office.
- (63) a. * Rosa was shouted [behind *t*] about her driving.
- b. Someone was shouting [behind Rosa_{*i*}] about her driving/*herself_{*i*}.
- c. Someone was shouting [behind her_{*i*}] that Rosa_{*i*}'s driving was insane.

I have proposed that the experiencer in an English raising construction is in a cascade PP. This proposal is more empirically adequate than another obvious possibility, namely that the experiencer is actually a DP, which c-commands directly into the embedded clause. Under this view, the *to* associated with the experiencer with *seem* would be treated as a Case marker on the DP. In fact, such a proposal would make exactly the wrong predictions. An experiencer DP would be the closest argument to T. All things being equal, this argument should itself be attracted to the subject position, just as in Icelandic (64a). However, as we have seen, Icelandic and English contrast in this respect (64b-c).

- (64) a. Mér virðist *t* [Haraldur hafa gert þetta vel].
 me.DAT seems H.NOM to have done this well
 ‘Harald seems to me to have done that well.’
- b. * To me seems *t* [Harold to have done that well].
- c. * I/me strike(s) *t* [as Harold having done that well].

As shown above for movement from within PP, the experiencer cannot raise even if the embedded subject is PRO, which is clearly permissible in a nonfinite clause (65). The experiencer also cannot raise if the embedded clause is finite, where again no problem arises with the embedded subject (66).

- (65) a. ?It was suggested to each boy [PRO to comb his hair].
 b. *To each boy was suggested [PRO to comb his hair].
- (66) a. It struck Greg [that he was quite fortunate].
 b. *Greg struck t [that he was quite fortunate].

Another possibility would be to suppose that the experiencer is a DP, but cannot itself be attracted to the subject position, as was argued for non-clitic(-doubled) experiencers in Greek, French, and Italian, and for all experiencers in Spanish. In this case, however, we would still expect the DP experiencer to block attraction of the embedded subject. Again, the prediction is not fulfilled: the embedded subject raises successfully past the experiencer in English. The contrast between English and Greek is repeated below.

- (67) a. ?* Ta pedhia fenonte tis Marias [t na dhiavazoun].
 the children.NOM seem.3PL the M.DAT SUBJ read.3PL
 ‘The children seem to Mary to study.’
- b. The children seem to Mary [t to be studying].
- c. The children strike Mary [as t having studied especially hard].

Finally, if the experiencer were a bare DP in English, it might be possible for the embedded subject to raise to the subject position via the checking domain occupied by the experiencer. In this case, however, we would expect Lethal Ambiguity effects between the two arguments, as we saw in French and Italian raising, as well as in other cases of A-movement through the checking domain occupied by another argument (68a). As we saw above, this prediction is also unconfirmed; once raised to the subject position, the embedded subject can bind the experiencer in English (68b-c).

- (68) a. *Gianni si sembra t [t fare il suo dovere].
 G. REFL seems to do his duty
 ‘Gianni seems to himself to do his duty.’
- b. Gayle seemed to herself [t to have done her duty].
- c. Greg struck himself [t as having done his duty especially well].

Thus I reject the hypothesis that the experiencer is a bare DP in either the *seem* or *strike* cases. As a DP, it would be eligible for attraction, leading to the wrong predictions, as we have seen. As a DP embedded in a cascade PP, the experiencer is ineligible for attraction, so it allows the embedded argument to raise past it without leapfrogging through the same checking domain.

To sum up, I have proposed that the experiencer in an English raising construction is in a cascade PP which allows it to bind into the embedded clause, and which does not permit the experiencer DP to move out of it. This claim is motivated by evidence that the embedded subject raises past the experiencer without occupying the same checking domain. To say that the DP cannot be attracted out of the PP is to say that this PP is not subject to the “reanalysis” that allows A-movement out of PP in a pseudopassive. “Reanalysis” is also impossible in French (69a), as noted by Kayne (1981). In fact, French even disallows preposition-stranding with *wh*-movement (69b).¹² Kayne attributes this difference between French and English to a difference in the Case properties of prepositions in the two languages.

- (69) a. * Jean a été voté [pp contre t] par presque tous.
 J. has been voted against by almost all
 ‘John was voted against by almost everyone.’
- b. * Quel candidat as-tu voté [pp pour t]?
 which candidate have-you voted for
 ‘Which candidate did you vote for?’ (Kayne 1981)

The same pattern of facts arises with experiencers in French (70): the experiencer cannot strand *à* either via A-movement or *wh*-movement. However, we have not

¹² Preposition-stranding by *wh*-movement is freer than pseudopassivization. Consider, for example, van Riemsdijk & Williams (1986:147):

- (i) How many hours did you argue for *t*?
 (ii) *Many hours were argued for *t*.

Maling & Zaenen (1985) also argue that Icelandic, Swedish and Danish allow preposition-stranding with *wh*-extraction and topicalization, but do not allow pseudopassivization.

entertained the notion that the nonclitic experiencer in French is embedded in a cascade PP. Rather, I have claimed that the experiencer in French is a DP, with \hat{a} marking dative Case.

- (70) a. * Jean semble $[_{PP} \hat{a} t]$ [Marie avoir du talent].
 J. seems to M. to have talent
 'Marie seems to Jean to have talent.'
- b. * Qui as-tu semblé $[_{PP} \hat{a} t]$ [t avoir du talent].
 who have-you seemed to to have talent
 'To whom did you seem to have talent?'

This claim is essentially intended to capture the difference in raising past the experiencer in French and English. In French, a non-clitic experiencer does block attraction of the embedded subject (71a). In English, however, the PP experiencer is ineligible for attraction to the subject position, so it does not block movement of the embedded subject (71b-c). Under the assumptions outlined here, the experiencer can block a lower argument from moving only if it is itself eligible for attraction. The experiencer in French, being a DP, is eligible for attraction to the specifier of TP. However, once there, it fails to check the Case feature of T, and the derivation crashes.

- (71) a. ?* Jean semble \hat{a} Marie [t avoir du talent].
 J. seems to M. to have of talent
 'Jean seems to Marie have talent.'
- b. The children seem to Mary [t to be studying].
- c. The children strike Mary [as t having studied especially hard].

Further evidence for the DP nature of \hat{a} -phrases can also be seen from their distribution in expletive constructions. Under the assumption that features of the indefinite associate are attracted to T, it must be possible to attract from the \hat{a} -phrase in (72a). However, if we maintain the view that prepositions in French do not allow reanalysis, features of a DP embedded in a PP should not be eligible for attraction. Such movement should only be possible if the \hat{a} -phrase is a bare DP. Like the experiencer, this DP cannot move to the subject position (72b), since it would leave the Case feature of T unchecked.

(72a) contrasts with (72c), where the expletive is ruled out. This contrast suggests that the *pour*-phrase is a genuine PP, from which features of the DP cannot be attracted.

- (72) a. Il sera procédé à une enquête.
 it will be proceeded to an inquiry
 'An inquiry will be conducted.'
- b. * A une enquête sera procédé *t*.
 an inquiry will be proceeded
 'An inquiry will be conducted.'
- c. * Il sera voté pour un candidate.
 it will be voted for a candidate
 'A candidate will be voted for.'

This section has laid out the evidence that the experiencer in an English raising construction c-commands into the embedded clause. I have argued that the experiencer is in a cascade PP, which is not eligible for attraction to the subject position. While this proposal is supported by the presence of a morphological preposition for the experiencer with *seem*, the experiencer with *strike* is not accompanied by a preposition. Rizzi (1986) argues that *strike* is not actually a raising verb at all. Moreover, Pesetsky (1995) presents evidence that might suggest that raising in general need not involve movement past the specifier. In the next section, I will argue explicitly that these constructions involve movement of the embedded subject past the experiencer.

2.2 *The embedded subject raises past the experiencer*

Raising constructions in English are of interest for locality because they involve movement of a DP past a c-commanding argument. If the subject were not derived by movement past the experiencer, these cases would raise no particular issue for locality. Unfortunately, this simpler view can be maintained. As we will see, there is good reason to believe that these constructions involve not only raising from the embedded clause, but also movement past the experiencer. Thus we are forced to an account like the one I have proposed here, where

the experiencer is itself ineligible for movement, so does not block movement of the embedded subject.

I will first review some of the standard arguments that *strike* involves raising from within an embedded clause. The main evidence is based on semantic constituency. In (73a) *strike* takes experiencer and clausal arguments, with the clause related to the expletive subject by feature-attraction to T. The claim is that the argument structure and interpretation of *strike* are essentially the same in (73b), with an experiencer (*me*) and a clausal argument introduced by *as*.

- (73) a. It struck me [that she is more intelligent than you think she is].
 b. She struck me [as *t* being more intelligent than you think she is].

It could be argued that *strike* can also take an experiencer and a DP theme, as in (74a).¹³

However, the marginality of (74a) contrasts sharply with the well-formedness of examples like (73b). This marginality does not improve if a clausal complement is added, as shown in (74b).

- (74) a. ?* She struck me (greatly / with her keen intelligence).
 b. * She struck me [that she is more intelligent than you think she is].

Further support for the raising analysis comes from examples like (75a), where the subject of the *strike* clause is “weather”-*it*. This example contrasts with cases lacking an *as*-clause. To the extent that such examples are acceptable at all, *it* cannot be interpreted as “weather”-*it* (75b).

- (75) a. It strikes me [as *t* being especially hot today].
 b. ?* It strikes me (greatly / with its excessive heat). (*it* ≠ *the weather*)

Nevertheless, Chomsky (1981) notes that certain raised subjects are more marginal with *strike*. These more marginal subjects include expletive *there* (76a) and idiom chunks (76b). Such examples are acceptable for some speakers, but not for all. At present I know of no principled explanation for their unacceptability.

¹³ *Strike* of course also has the meaning ‘hit,’ which is by far the preferred reading of simple examples with two animate arguments, such as *She strikes me*.

- (76) a. # There strikes me [t as being no alternative].
 b. # The shit strikes me [t as having hit the fan particularly often this year].

In any case, the facts discussed above provide evidence that the subject raises from within the embedded clause, rather than being generated independently.

Even so, it is conceivable that the embedded subject of a raising construction moves to the subject position without moving past the experiencer. It has been claimed in the literature that a finite clausal complement originates as the higher object in a double-object construction, and undergoes heavy shift (Stowell 1981). If nonfinite clauses are generated in the same position, the experiencer would not intervene between the embedded subject and the matrix subject position until heavy shift has occurred. However, I will argue that, even if a nonfinite clause is generated above the experiencer, the embedded subject cannot be attracted to the matrix subject position until the clause has undergone heavy shift. Thus in any case the subject must raise past the experiencer.

Pesetsky (1995:275) reviews one of the arguments for heavy shift of finite clauses (cf. Alexander & Kunz 1964, Higgins 1973, Postal 1986). The argument comes from an observation about pseudopassives. As noted above, the relation or operation permitting pseudopassivization is not understood; however, it is known to be blocked by material intervening between the verb and the preposition. Contrast the well-formed case of pseudopassivization in (77) from the ill-formed case in (78), where the object *many letters* intervenes. Interestingly, pseudopassivization is blocked even if the object undergoes heavy shift to the right, as in (79).¹⁴

- (77) a. Many people wrote to the senator (about the test ban treaty).
 b. The senator was written to [t (by many people) (about the test ban treaty)].

¹⁴ Pesetsky (1995) argues that heavy shift is downward movement. It is not clear exactly what the best way is to capture the relevant facts under the assumption of this thesis that all movement is upwards. Phillips (1996) captures these effects using a model in which grammatical structures are built from the top down, rather than from the bottom up. Phillips distinguishes between (downward) movement due to parsing reanalysis and (upward) movement driven by feature-checking.

- (78) a. We wrote many letters to the senator (about the test ban treaty).
 b. *The senator was written many letters to *t* (about the test ban treaty).
- (79) a. We wrote *t* to the senator [an avalanche of letters he couldn't ignore].
 b. *The senator was written *t* to *t* [an avalanche of letters he couldn't ignore].

The same generalization applies when the “theme” argument is a finite clause, rather than a heavy DP. When no clause is present, pseudopassivization is fine, as in (80). When a clause is added, pseudopassivization is ill-formed, even though the overt position of the clause does not intervene between the verb and the preposition. This contrast suggests that the clause has undergone rightward heavy shift from an intervening position, as shown in (81b).

- (80) a. Melvin confessed to the priest.
 b. The priest was confessed to *t*.
- (81) a. Melvin confessed to the priest that he had sinned.
 b. * [The priest] was confessed *t* to *t* [that someone had sinned].

Given this underlying structure, we might expect that the nonfinite clause of a raising construction also intervenes between the verb and the PP experiencer, then undergoing rightward heavy shift. In fact, this derivation might explain the observation in the previous section that “reanalysis” is impossible in raising constructions; the experiencer cannot A-move out of its cascade PP, leaving a stranded preposition. As we saw, reanalysis is impossible whether the clausal complement is finite or not.

Nevertheless, there is reason to believe that the experiencer intervenes between the embedded subject and the subject position of the matrix clause. In particular, as we have seen, the experiencer can block movement of the embedded subject, as shown for Greek in (82), and can even be attracted to the subject position itself, as in Icelandic (83).

- (82) a. O Jannis fenete [*t* eksipnos].
 the J.NOM seems intelligent
 ‘John seems intelligent.’

- b. ?* O Jannis fenete tis Marias [_t eksipnos].
 the J.NOM seems the M.DAT intelligent
 'John seems to Mary intelligent.'
- (83) a. Jón telur [Harald virðast hafa gert þetta vel].
 J.NOM believes H.ACC to.seem to.have done this well
 ('Jon believes Harald to seem to have done this well.')
- b. Jón telur [mér virðast Haraldur hafa gert þetta vel].
 J.NOM believes me.DAT to.seem H.NOM to.have done this well
 'Jon believes Harald to seem to me to have done this well.'
- c. *Jón telur [Harald virðast mér hafa gert þetta vel].
 J.NOM believes H.ACC to.seem me.DAT to.have done this well
 'Jon believes Harald to seem to me to have done this well.'

Under the theory I have presented here, the experiencer blocks movement of the embedded subject because it is itself a closer eligible argument for attraction. Such blocking would be impossible if the experiencer did not intervene between the embedded subject and the matrix subject position.

One possible move here would be to say that the experiencer is generated above the embedded clause in some languages (e.g. French, Italian, Greek, Spanish, Icelandic), and below the embedded clause in others (e.g. English). This is not the position I wish to take, however. I will assume that the order of projection of experiencers and clauses is uniform across languages, so that the experiencer will always c-command the embedded subject at the point in the derivation where the embedded subject is attracted to the matrix subject position. If the clause does in fact occupy a position c-commanding the experiencer at some stage in the derivation, I am forced to conclude that the embedded subject cannot be attracted out of the clause in this position.

In this section, I have argued that the experiencer in an English raising construction is a PP, which is not eligible for attraction to the subject position. As a result, the embedded subject can be attracted past it without a violation of locality. As an addendum, it should be noted that there are some English speakers for whom raising past an experiencer is quite marginal (80a), though there is no independent problem with an experiencer (80b)

or with raising (80c).¹⁵ For these speakers, the intervening experiencer blocks the embedded subject from raising to the matrix subject position, just as discussed for Greek, French, Italian and Spanish in Chapter 3.

- (84) a. * She seems to me [*t* to have been quite fortunate].
 b. It seems (to me) [that she was quite fortunate].
 c. She seems [*t* to have been quite fortunate].

The same effect has also been observed in subject-control configurations, as shown in (85): for some speakers, subject control into an infinitival clause is impossible if an object intervenes (81a), though objects (81b) and subject control (81c) are independently well-formed.

- (85) a. * I promised John [PRO to go to Minneapolis].
 b. I promised (John) [that I would go to Minneapolis].
 c. I promised [PRO to go to Minneapolis].

Raising the embedded subject past an experiencer argument of *strike* is also marginal for some speakers (86a). While the unraised version with an experiencer is fine (86b), there is of course no way to raise independently, since the experiencer is obligatory (86c).

- (86) a. * She strikes me [as *t* having been quite fortunate].
 b. It strikes me [that she was quite fortunate].
 c. * She strikes [as *t* having been quite fortunate].

We have now seen two cases in which a lower argument raises past a higher one without leapfrogging through the same checking domain. In the first case, the higher argument is an anaphoric or arbitrary external argument, which lacks the feature specifications necessary to qualify as a DP. In the second, I have argued that the higher argument is a PP experiencer. To these cases I would like to add a third, as yet not widely recognized in the literature. This case involves an unaccusative construction with two

¹⁵ Thanks to David Pesetsky for pointing out the raising and control facts discussed here, and thanks to Paul Hagstrom and Julie Legate for their judgements.

internal arguments in Georgian (McGinnis 1997, 1998). I will briefly mention these before concluding this chapter.

3 Ditransitive unaccusatives in Georgian

Given a verb phrase with unaccusative *v* and R as well as the main verb V, we would expect the highest argument to raise to the subject position. This is essentially the structure we have assumed for subject-experiencer constructions in at least some languages, such as Icelandic and Georgian, where the experiencer has dative Case. Recall that the dative argument can bind a nominative object (87a) but not vice versa (87b), in both cases regardless of word order.

- (87) a. Vano-s tavisi tav-i u-qvar-s.
 V.-DAT self-NOM R-love-PRES
 'Vano loves himself.'
- b. *Vano tavis tav-s u-qvar-s.
 V.-NOM self-DAT R-love-PRES
 'Himself loves Vano.'

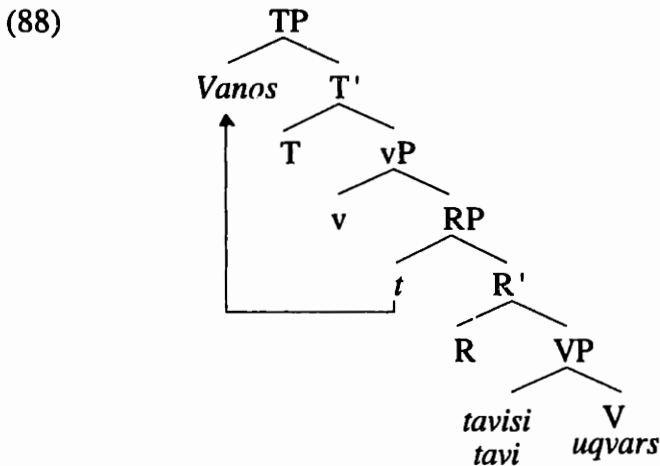

In some instances, however, the higher argument does not raise to the subject position. For these cases, I again propose that the higher argument is a PP rather than a DP. As a result, the lower argument can raise past it without occupying the same checking domain. There are cases in Georgian in which the lower “theme” argument raises past the higher

experiencer to the subject position, triggering subject-verb agreement (89a) just as in the simple unaccusative (89b).

- (89) a. Bavšveb-i vano-s e-mal-eb-ian.
 children-NOM V.-DAT R.UNACC-hide-TS-PRES.PL
 'The children are hidden from Vano.'
- b. Bavšveb-i i-mal-eb-ian.
 children-NOM UNACC-hide-TS-PRES.PL
 'The children are hidden.' (Nash 1995)

The raised nominative argument can then bind the dative argument, as shown in (86). The opposite binding pattern is impossible (90b). Again, these judgements hold regardless of word order. I assume that the word order in (90b) is derived by scrambling the dative argument over the nominative one. If it undergoes A-bar scrambling, or fails to undergo scrambling at all, the dative argument is not in a position to bind the anaphor. However, if it undergoes A-scrambling, Lethal Ambiguity arises and binding is ruled out.¹⁶

- (90) a. Nino tavis tav-s e-mal-eb-ian.
 N.NOM self-DAT R.UNACC-hide-TS-PRES.PL
 'Nino is hidden from herself.'
- b. *Nino-s tavis tav-i e-mal-eb-ian.
 N.DAT self-NOM R.UNACC-hide-TS-PRES.PL
 'Herself is hidden from Nino.' (Nash, p.c.)

The unaccusative in (90) contrasts with its agentive counterpart, in which the dative indirect object dative argument can bind the "theme," but not vice versa (91). Assuming that the two arguments are generated in the same order in the two cases, we are led to conclude that one of the arguments raises past the other without moving through the same checking domain. I will assume that (90) is the case where such movement occurs, since we need to assume in any case that the nominative argument raises to the subject position. The indirect object in (90) is then a PP, which allows the DP theme to move past it to the subject position without leapfrogging through the same checking domain. In (91), the indirect object is also a PP, but movement of the direct object in (91a) is motivated by a scrambling

¹⁶ Other verbs that allow binding of the DAT anaphor include *gaekca* 'escape from' and *ecxuba* 'fight with.'

feature on the head (R) with the indirect object in its specifier. The indirect object thus occupies the same checking domain, and Lethal Ambiguity effects arise.

- (91) a. * Vano-m Nino tavis tav-s da-u-mal-a.
 V.-ERG N.NOM self-DAT PREV-R-hide-AOR
 ‘Vano hid Nino, from herself.’
- b. Vano-m Nino-s tavis tav-i da-u-mal-a.
 V.-ERG N.DAT self-NOM PREV-R-hide-AOR
 ‘Vano hid herself, from Nino.’

The Georgian unaccusatives in (90) can also be contrasted with the double-object passive in Albanian. As we saw in previous chapters, the indirect object in Albanian c-commands the direct object in an active ditransitive (92a). In the passive, the direct object raises past the higher indirect object (92b). In Albanian, however, the indirect object is a DP, so the direct object must raise through the same checking domain, giving rise to Lethal Ambiguity effects (92c).

- (92) a. Agimi ia dha secilit djalë pagën e tij.
 A.NOM CL give each boy.DAT pay.ACC his
 ‘Agim gave to each boy his pay.’
- b. Secili djale iu tregua babes te tij t.
 each boy.NOM CL show.NACT father his.DAT
 ‘Each boy was shown to his father.’
- c. * Drita iu tregua vetes t prej artistit.
 Drita.NOM CL show.NACT self.DAT by the.artist
 ‘Drita was shown to herself by the artist.’

By contrast, in Georgian unaccusatives like those in (90), the direct object can raise past the indirect object and bind it directly. The Georgian cases thus furnish another plausible instance in which a lower DP raises past a higher PP argument without leapfrogging through the same checking domain.

4 Summary

In this chapter I have argued that a lower argument can be attracted past a higher one without leapfrogging through the same checking domain. Such a derivation is possible

only if the higher argument lacks the feature being attracted. I suggested three possible cases where this situation arises. First, constructions with an anaphoric clitic/affix involve a lower argument moving past the external argument without stopping off in the same checking domain. This derivation is also available for arbitrary external arguments. I proposed that these arguments can be featurally impoverished to the extent that they lack the D-features necessary for attraction to T. As a result, the lower argument is the closest eligible argument for attraction. A PP argument likewise permits a DP to be attracted past it without leapfrogging through the same checking domain. I proposed that the experiencer argument is a PP in English raising constructions with *seem* and *strike*. Likewise, in certain unaccusatives in Georgian, the higher internal argument is a PP, which allows the lower internal argument to raise past it to the subject position. In all three cases, the raised argument can bind the argument it raises past. These cases demonstrate that Lethal Ambiguity effects arise only in a subset of the cases involving movement of one argument past another to a c-commanding position. I have argued that the relevant distinction is between derivations that do and do not feature the two arguments in specifiers of the same head.

References

- Aissen, Judith. 1987. *Tzotzil clause structure*. Dordrecht: Kluwer.
- Alsina, Alex, & Sam Mchombo. 1993. Object asymmetries in the Chicheŵa applicative construction. In Mchombo 1993.
- Alexander, D., & W. J. Kunz. 1964. Some classes of verbs in English. Linguistics Research Project, Indiana University, Bloomington.
- Anagnostopoulou, Elena. 1994. *Clitic dependencies in Modern Greek*. Doctoral dissertation, Universität Salzburg.
- Anagnostopoulou, Elena. 1997. Goals, benefactors, experiencers and the syntax of clitic doubling. Talk presented at Rutgers University, December 5.
- Anagnostopoulou, Elena. 1998. Dative arguments and clitic doubling. Talk presented at MIT, March 5.
- Andrews, Avery. 1982. The representation of case in Modern Icelandic. In Joan Bresnan, ed., *The mental representation of grammatical relations*. Cambridge, MA: MIT Press.
- Aronson, Howard I. 1990. *Georgian: A reading grammar*. Corrected edition. Columbus, OH: Slavica.
- Baker, Mark. 1988a. *Incorporation: A theory of grammatical function changing*. Chicago: University of Chicago Press.
- Baker, Mark. 1988b. Theta theory and the syntax of applicatives in Chicheŵa. *Natural Language and Linguistic Theory* 6: 353–389.
- Baker, Mark, Kyle Johnson, & Ian Roberts. Passive arguments raised. *Linguistic Inquiry* 20, 219–251.
- Baltin, Mark, & Paul M. Postal. 1996. More on reanalysis hypotheses. *Linguistic Inquiry* 27, 127–45.

- Barbosa, Maria do Pilar Pereira. 1995. *Null subjects*. Doctoral dissertation, MIT.
- Barss, Andrew, & Howard Lasnik. 1986. A note on anaphora and double objects. *Linguistic Inquiry* 17, 219–251.
- Belletti, Adriana, & Luigi Rizzi. 1988. Psych-verbs and θ -theory. *Natural Language and Linguistic Theory* 6, 291–352.
- Berent, Gerald P. 1980. On the realization of trace: Macedonian clitic pronouns. In Catherine V. Chvany, Richard D. Brecht, eds., *Morphosyntax in Slavic*. Columbus: Slavica.
- Bobaljik, Jonathan. 1993. Ergativity and ergative unergatives. In Colin Phillips, ed., *MIT Working Papers in Linguistics 19: Papers on case & agreement II*. Department of Linguistics and Philosophy, MIT.
- Bobaljik, Jonathan. 1995. *Morphosyntax: The syntax of verbal inflection*. Doctoral dissertation, MIT. Distributed by MIT Working Papers in Linguistics.
- Bobaljik, Jonathan, & Dianne Jonas. 1996. Subject positions and the roles of TP. *Linguistic Inquiry* 27, 195–236.
- Bonet, Eulàlia. 1991. *Morphology after syntax: Pronominal clitics in Romance*. Doctoral dissertation, MIT. Distributed by MIT Working Papers in Linguistics.
- Bowers, John. 1993. The syntax of predication. *Linguistic Inquiry* 24, 591–656.
- Bresnan, Joan. 1982. The passive in lexical theory. In Joan Bresnan, ed., *The mental representation of grammatical relations*. Cambridge, MA: MIT Press.
- Bresnan, Joan. 1994. Locative inversion and the architecture of Universal Grammar. *Language* 70, 72–131.
- Bresnan, Joan, & Lioba Moshi. 1990. Object asymmetries in comparative Bantu syntax. *Linguistic Inquiry* 21, 147–185.
- Bresnan, Joan, & Lioba Moshi. 1993. Object asymmetries in comparative Bantu syntax. In Mchombo 1993.
- Burzio, Luigi. 1981. *Intransitive verbs and Italian auxiliaries*. Doctoral dissertation, MIT.
- Chomsky, Noam. 1964. *Current issues in linguistic theory*. The Hague, Mouton.
- Chomsky, Noam. 1981. *Lectures on government and binding: The Pisa lectures*. The Hague: Mouton.
- Chomsky, Noam. 1986. *Knowledge of language*. New York: Praeger.
- Chomsky, Noam. 1993. A minimalist program for linguistic theory. In Hale & Keyser 1993b.

- Chomsky, Noam. 1995. *The minimalist program*. Cambridge, MA: MIT Press.
[References in the text to Chomsky 1995 are to Chapter 4, Categories and transformations.]
- Chomsky, Noam. 1998. Minimalist inquiries: The framework. Ms., MIT.
- Chomsky, Noam, & Howard Lasnik. 1993. The theory of principles and parameters. In Joachim Jacobs, Arnim von Stechow, Wolfgang Sternefeld, & Theo Vennemann, eds., *Syntax: An international handbook of contemporary research*. Berlin: De Gruyter. Reprinted in Chomsky 1995.
- Cinque, Guglielmo. 1988. On *si* constructions and the theory of *arb*. *Linguistic Inquiry* 19, 521–581.
- Collins, Chris. 1997. *Local economy*. Cambridge, MA: MIT Press.
- Collins, Chris, & Höskuldur Thráinsson. 1996. VP-internal structure and object shift in Icelandic. *Linguistic Inquiry* 27, 391–444.
- Davidson, Donald. 1967. The logical form of action sentences. In Nicholas Rescher, ed., *The logic of decision and action*. Pittsburgh: University of Pittsburgh Press.
- Diesing, Molly. 1990. *The syntactic roots of semantic partition*. Doctoral dissertation, University of Massachusetts, Amherst. Distributed by GLSA, UMass Amherst.
- Diesing, Molly. 1992. Semantic variables and object shift. In Höskuldur Thráinsson, Samuel D. Epstein, & Steve Peter, eds., *Studies in comparative Germanic syntax*, Volume II. Dordrecht: Kluwer.
- Dixon, Robert M. W. 1972. *The Dyirbal language of North Queensland*. London: Cambridge University Press.
- Dobrovie-Sorin, Carmen. 1990. Clitic doubling, *wh*-movement and quantification in Romanian. *Linguistic Inquiry* 21, 351–397.
- Dobrovie-Sorin, Carmen. 1998. Impersonal *se* constructions in Romance and the passivization of unergatives. *Linguistic Inquiry* 29, 399–437.
- Embick, David. 1997. *Voice and the interfaces of syntax*. Doctoral dissertation, University of Pennsylvania.
- Engdahl, Elisabet. 1983. Parasitic gaps. *Linguistics and Philosophy* 6, 5–34.
- Epstein, Samuel. 1994. The derivation of syntactic relations. Ms., Harvard University.
- Everaert, Martin, & Elena Anagnostopoulou. 1996. Thematic hierarchies and binding theory: Evidence from Greek. Paper presented at the First Linguist On-Line Conference: Geometric and Thematic Structure in Binding, October 14–November 4.

- Falk, Cecilia. 1990. On double object constructions. *Working Papers in Scandinavian Syntax* 46, 53–100. Department of Scandinavian Linguistics, Lund University.
- Fox, Danny. 1993. Condition C effects in ACD. In Rob Pensalfini & Hiroyuki Ura, eds., *MIT Working Papers in Linguistics 27: Papers on minimalist syntax*. Department of Linguistics and Philosophy, MIT.
- George, Leland M., & Jaklin Kornfilt. 1981. Finiteness and boundedness in Turkish. In Frank Heny, ed., *Binding and filtering*. Cambridge, MA: MIT Press.
- Goodall, Grant. 1997. θ -alignment and the *by*-phrase. In *Papers from the Thirty-Third Regional Meeting, Chicago Linguistics Society, Volume 1*. Chicago University Society, University of Chicago.
- Grewendorf, Gunther, & Wolfgang Sternefeld. 1990. Scrambling theories. In Gunther Grewendorf & Wolfgang Sternefeld, eds., *Scrambling and Barriers*. Amsterdam: Benjamins.
- Grimshaw, Jane. 1982. On the lexical representation of Romance reflexive clitics. In Joan Bresnan, ed., *The mental representation of grammatical relations*. Cambridge, MA: MIT Press.
- Grimshaw, Jane. 1990. *Argument structure*. Cambridge, MA: MIT Press.
- Hale, Kenneth L., & Samuel J. Keyser. 1993a. On argument structure and the lexical expression of syntactic relations. In Hale & Keyser 1993b.
- Hale, Kenneth L., & Samuel J. Keyser, eds. 1993b. *The view from Building 20*. Cambridge, MA: MIT Press.
- Harada, S.-I. 1971. *Ga-no* conversion and idiolectal variations in Japanese. *Gengo Kenkyuu* 60, 25–38.
- Harada, S.-I. 1976. Honorifics. In Masayoshi Shibatani, ed., *Japanese generative grammar: Syntax and Semantics* 5. 499–561. New York: Academic Press.
- Harley, Heidi. 1995. *Subjects, events, and licensing*. Doctoral dissertation, MIT. Distributed by MIT Working Papers in Linguistics.
- Harris, Alice. 1981. *Georgian syntax: A study in Relational Grammar*. Cambridge: Cambridge University Press.
- Heim, Irene, Howard Lasnik, & Robert May. 1991. Reciprocity and plurality. *Linguistic Inquiry* 22, 63–101.
- Henry, Alison. 1995. *Belfast English and standard English: Dialect variation and parameter setting*. New York: Oxford University Press.
- Herslund, Michael. 1986. The double object construction in Danish. In Lars Hellan, Kirsti Koch Christensen, eds., *Topics in Scandinavian Syntax*. Dordrecht: Reidel.

- Higgins, F. R. 1973. *The pseudo-cleft construction in English*. Doctoral dissertation, MIT. Published by Garland, New York.
- Hoji, Hajime. 1985. *Logical Form constraints and configurational structures in Japanese*. Doctoral dissertation, University of Washington, Seattle.
- Holmberg, Anders. 1991. On the Scandinavian double object construction. In *Papers from the 12th Scandinavian Conference on Linguistics*. Institute of Linguistics, University of Iceland, Reykjavík.
- Holmberg, Anders. 1997. The true nature of Holmberg's Generalization. In Kiyomi Kusumoto, ed., *Proceedings of NELS 27*. GLSA, University of Massachusetts, Amherst.
- Holmberg, Anders, & Christer Platzack. 1995. *The role of inflection in Scandinavian syntax*. New York: Oxford University Press.
- Iatridou, Sabine. 1988. Clitics, anaphors, and a problem of coindexation. *Linguistic Inquiry* 19, 698–703.
- Iatridou, Sabine. 1990. About Agr(P). *Linguistic Inquiry* 21, 551–577.
- Jackendoff, Ray. 1990. On Larson's treatment of the double object construction. *Linguistic Inquiry* 21, 427–456.
- Jonas, Dianne. 1996. *Clause structure and verb syntax in Scandinavian and English*. Doctoral dissertation, Harvard University. [Examples taken from dissertation defense handout, Harvard University, September 16, 1995.]
- Jonas, Dianne. 1998. Formal features, licensing and clause structure. Talk presented at MIT, May 1.
- Jones, Douglas. *Binding as an interface condition: An investigation of Hindi scrambling*. Doctoral dissertation, MIT. Distributed by MIT Working Papers in Linguistics.
- Joseph, Brian D., & Irene Philippaki-Warbuton. 1987. *Modern Greek*. London: Croom Helm.
- Kayne, Richard. 1975. *French syntax*. Cambridge, MA: MIT Press.
- Kayne, Richard. 1981. ECP extensions. *Linguistic Inquiry* 12, 92–133.
- Kayne, Richard. 1984. Datives in French and English. In Richard Kayne, *Connectedness and binary branching*. Dordrecht: Foris.
- Kayne, Richard. 1986. Thematic and Case-assigning properties of past participles. Paper presented at the Princeton Workshop on Comparative Grammar, Princeton University.
- Kitagawa, Yoshihisa. 1986. *Subjects in Japanese and English*. Doctoral dissertation, University of Massachusetts, Amherst.

- Klokeid, Terry J. 1976. *Topics in Lardil grammar*. Doctoral dissertation, MIT.
- Koizumi, Masatoshi. 1995. *Phrase structure in minimalist syntax*. Doctoral dissertation, MIT. Distributed by MIT Working Papers in Linguistics.
- Kratzer, Angelika. 1993. On external arguments. *University of Massachusetts (Amherst) Occasional Papers* 17, 103–130.
- Kratzer, Angelika. 1996. Severing the external argument from its verb. In Johan Rooryck & Laurie Zaring, eds., *Phrase structure and the lexicon*, 109–137. Dordrecht: Kluwer.
- Kubo, Miori. 1990. Japanese passives. Ms., MIT. Published in *Language and Culture* 23 (1992), 231–302.
- Kuno, Susumu. 1973. *The structure of the Japanese language*. Cambridge, MA: MIT Press.
- Kuroda, S.-Y. 1988. Whether we agree or not: A comparative syntax of English and Japanese. In William Poser, ed., *Papers from the Second International Workshop on Japanese Syntax*. Stanford, CA: CSLI Publications. Distributed by Chicago University Press.
- Landau, Idan. 1998. Projection and bounding in possessor raising. Paper presented at the Seventeenth Annual Meeting of the West Coast Conference on Formal Linguistics. University of British Columbia, Vancouver, February 20–22. To appear in the Proceedings.
- Larson, Richard. 1988. On the double object construction. *Linguistic Inquiry* 19, 335–391.
- Larson, Richard. 1990. Double objects revisited: Reply to Jackendoff. *Linguistic Inquiry* 21, 589–632.
- Lasnik, Howard. 1995. Last Resort and Attract F. In L. Gabriele, D. Hardison and R. Westmoreland, eds., *FLSM VI: Proceedings of the Sixth Annual Meeting of the Formal Linguistics Society of Mid-America, Volume 1*. Bloomington, IN: Indiana University Linguistics Club Publications.
- Laughlin, Robert M. 1977. Of cabbages and kings: Tales from Zinacantan. *Smithsonian Contributions to Anthropology* 23.
- Lebeaux, David. 1983. A distributional difference between reciprocals and reflexives. *Linguistic Inquiry* 14, 723–730.
- Lidz, Jeffrey. 1996. *Dimensions of reflexivity*. Doctoral dissertation, University of Delaware.
- Mahajan, Anoop Kumar. 1990. *The A/A-bar distinction and movement theory*. Doctoral dissertation, MIT. Distributed by MIT Working Papers in Linguistics.

- Maling, Joan, & Zaenen, Annie. 1985. Preposition-stranding and passive. *Nordic Journal of Linguistics* 8, 197–209. Reprinted in Joan Maling & Annie Zaenen, eds., *Modern Icelandic Syntax*. San Diego: Academic Press, 1990.
- Marantz, Alec. 1984. *On the nature of grammatical relations*. Cambridge, MA: MIT Press.
- Marantz, Alec. 1989. Relations and configurations in Georgian. Ms., University of North Carolina, Chapel Hill.
- Marantz, Alec. 1991. Case and licensing. In Germán F. Westphal, Benjamin Ao, & Hee-Rahk Chae, eds., *ESCOL '91: Proceedings of the Eighth Eastern States Conference on Linguistics*. Distributed by the ESCOL Publications Committee.
- Marantz, Alec. 1993. Implications of asymmetries in double object constructions. In Mchombo 1993.
- Marantz, Alec. 1995. The Minimalist Program. In Gert Webelhuth, ed., *Government and Binding theory and the Minimalist Program: Principles and parameters in syntactic theory*. Oxford: Blackwell.
- Marantz, Alec. 1997. No escape from syntax: Don't try morphological analysis in the privacy of your own lexicon. Paper presented at the 21st Penn Linguistics Colloquium. To appear in the *University of Pennsylvania Working Papers in Linguistics*, Volume 4.2. Department of Linguistics, University of Pennsylvania.
- Martin, R. 1970. La transformation impersonnelle. *Revue de Linguistique Romane* 34, 337–394.
- Massey, Victoria Walker. 1990. Experiencers, themes, and c-command in Albanian. In Thomas Green & Sigal Uziel, eds., *MIT Working Papers in Linguistics 12: Papers from the second Student Conference in Linguistics*. Department of Linguistics and Philosophy, MIT.
- Massey, Victoria Walker. 1992. *Compositionality and constituency in Albanian*. Doctoral dissertation, University of North Carolina, Chapel Hill. *MIT Occasional Papers in Linguistics* 3. Department of Linguistics and Philosophy, MIT.
- McCloskey, James. 1997. Subjects and subjecthood. In Liliane Haegeman, ed., *Elements of grammar*. Boston: Kluwer.
- Mchombo, Sam, ed. 1993. *Theoretical aspects of Bantu grammar*. Stanford: CSLI Publications.
- McGinnis, Martha. 1995. Projection and position: Evidence from Georgian. In João Costa, Rob Goedemans, & Reuben van der Vijver, eds., *Proceedings of ConSole IV*. Leiden: HIL.
- McGinnis, Martha. 1997. Reflexive external arguments and lethal ambiguity. Talk presented at the Sixteenth West Coast Conference on Formal Linguistics. To appear in the Proceedings. Stanford: CSLI Publications.

- McGinnis, Martha. 1998. Case and locality in I-syntax: Evidence from Georgian. In Heidi Harley, ed., *MIT Working Papers in Linguistics 32: Papers from the UPenn/MIT Roundtable on Argument Structure and Aspect*. Department of Linguistics and Philosophy, MIT.
- Mendikoetxea, Amaya. 1992. *On the nature of agreement: The syntax of arb se in Spanish*. Doctoral dissertation, University of York.
- Miyagawa, Shigeru. 1997. Against optional scrambling. *Linguistic Inquiry* 28, 1–25.
- Nash-Haran, Léa. 1992. La catégorie AGR et l'accord en géorgien. *Recherches Linguistiques* 21, 65–79.
- Nash, Léa. 1995. *Portée argumentale et marquage casuel dans les langues SOV et dans les langues ergatives: L'exemple du géorgien*. Doctoral dissertation, Université de Paris 8.
- Nash, Léa. 1996. The Internal Ergative Subject Hypothesis. In Kiyomi Kusumoto, ed., *Proceedings of NELS 26*. GLSA, University of Massachusetts, Amherst.
- Ndayiragije, Juvénal. 1996. Case checking and OVS in Kirundi. In Anna-Maria Di Sciullo, ed., *Configurations: Essays on structure and interpretation*. Somerville, MA: Cascadilla Press.
- Ndayiragije, Juvénal. 1997. Checking economy. Ms., University of Western Ontario. To appear in *Linguistic Inquiry*.
- Nishiyama, Kunio. 1998. *The morphosyntax and morphophonology of Japanese predicates*. Doctoral dissertation, Cornell University.
- Oehrle, Richard, & Hiroko Nishio. 1981. Adversity. In Ann Kathleen Farmer & Chisato Kitagawa, eds., *Coyote Papers: Working Papers in Linguistics from A → Z*, Volume 2. Department of Linguistics, University of Arizona.
- Ottósson, Kjartan. 1991. Icelandic double objects as small clauses. In *Working Papers in Scandinavian syntax* 48, 77–97. Department of Scandinavian Linguistics, Lund University.
- Parsons, Terence. 1990. *Events in the semantics of English: A study of subatomic sentences*. Cambridge, MA: MIT Press.
- Perlmutter, David. 1984. Working 1s and inversion in Italian, Japanese and Quechua. In David Perlmutter & Carol Rosen, eds., *Studies in Relational Grammar 2*. Chicago: University of Chicago Press.
- Pesetsky, David. 1995. *Zero syntax: Experiencers and cascades*. Cambridge, MA: MIT Press.
- Phillips, Colin. 1996. *Order and structure*. Doctoral dissertation, MIT. Distributed by MIT Working Papers in Linguistics.

- Postal, Paul. 1986. *Studies of passive clauses*. Albany: SUNY Press.
- Postal, Paul. 1971. *Cross-over phenomena*. New York: Holt, Rinehart and Winston.
- Postma, Gerrit Jan. 1995. *Zero Semantics: A study of the syntactic conception of quantificational meaning*. Doctoral dissertation, HIL.
- Reinhart, Tanya. 1981. Definite NP anaphora and c-command domains. *Linguistic Inquiry* 12, 605–635.
- Reinhart, Tanya. 1983. Coreference and bound anaphora: A restatement of the anaphora questions. *Linguistics and Philosophy* 6, 47–88.
- Reinhart, Tanya. 1996. Syntactic effects of lexical operations: Reflexives and unaccusatives. Ms., University of Utrecht. Published by OTS Working Papers in Linguistics, 1997.
- Richards, Norvin. 1997a. Competition and disjoint reference. *Linguistic Inquiry* 28, 178–187.
- Richards, Norvin. 1997b. *What moves where when in which language?* Doctoral dissertation, MIT. Distributed by MIT Working Papers in Linguistics.
- Riemsdijk, Henk van, & Edwin Williams. 1986. *Introduction to the theory of grammar*. Cambridge, MA: MIT Press.
- Rizzi, Luigi. 1986. On chain formation. In Hagit Borer, ed., *The syntax of pronominal clitics: Syntax and Semantics 19*. New York: Academic Press.
- Rizzi, Luigi. 1990. *Relativized minimality*. Cambridge, MA: MIT Press.
- Rögvaldsson, Eiríkur. 1982. *Um orðaröð og færslur í nútímatlensku*. Master's thesis, University of Iceland, Reykjavík. Published by Institute of Linguistics, University of Iceland, Reykjavík.
- Rothstein, Susan. 1983. *The syntactic forms of predication*. Doctoral dissertation, MIT.
- Rouveret, Alain, & Jean-Roger Vergnaud. 1980. Specifying reference to the subject: French causatives and conditions on representations. *Linguistic Inquiry* 11, 97–202.
- Rudin, Catherine. 1988. On multiple questions and multiple *wh*-fronting. *Natural Language and Linguistic Theory* 6, 445–501.
- Saito, Mamoru. 1989. Scrambling as semantically vacuous A'-movement. In Mark R. Baltin & Anthony S. Kroch, eds., *Alternative conceptions of phrase structure*. Chicago: University of Chicago Press.
- Saito, Mamoru. 1992. Long distance scrambling in Japanese. *Journal of East Asian Linguistics* 1, 69–118.

- Saito, Mamoru, & Hajime Hoji. 1983. Weak crossover and Move α in Japanese. *Natural Language and Linguistic Theory* 1, 245–259.
- Schafer, Robin. 1994. Negation and verb second in Breton. *Natural Language and Linguistic Theory* 13, 135–172.
- Schütze, Carson. 1997. *INFL in child and adult language: Agreement, case and licensing*. Doctoral dissertation, MIT. Distributed by MIT Working Papers in Linguistics.
- Sherman, Adam. 1997. Focus and word order in Modern Hebrew. Ms., University of California, Santa Cruz.
- Shibatani, Masayoshi. 1977. Grammatical relations and surface Cases. *Language* 53, 789–809.
- Sigurðsson, Halldór Ármann. 1989. *Verbal syntax and case in Icelandic*. Doctoral dissertation, University of Lund. Reprinted Reykjavík: Institute of Linguistics, University of Iceland (1992).
- Snyder, William. 1992. Chain-formation and crossover. Ms., MIT.
- Soriano, Olga. 1998. On impersonal sentences in Spanish: Locative and dative subjects. Ms., MIT/Universidad Autónoma de Madrid.
- Sportiche, Dominique. 1988. A theory of floating quantifiers and its corollaries for constituent structure. *Linguistic Inquiry* 19, 425–449.
- Srivastav, Veneeta Dayal. 1993. Binding facts in Hindi and the scrambling phenomenon. In Miriam Butt, Tracy Holloway King, & Gillian Ramchand, eds., *Theoretical perspectives on word order in South Asian Languages*. Stanford, CA: CSLI Publications.
- Stowell, Tim. 1981. *Origins of phrase structure*. Doctoral dissertation, MIT.
- Suñer, Margarita. 1988. The role of agreement in clitic-doubled constructions. *Natural Language and Linguistic Theory* 6, 391–434.
- Takano, Yuji. 1997. Object shift and scrambling. Ms., Keio University. To appear in *Natural Language and Linguistic Theory*.
- Taraldsen, Knut Tarald. 1994. Reflexives, pronouns, and subject/verb agreement in Icelandic and Faroese. *Working Papers in Scandinavian Syntax* 54, 43–58. Department of Scandinavian Linguistics, Lund University.
- Thráinsson, Höskuldur. 1979. *On complementation in Icelandic*. New York: Garland.
- Toribio, Almeida Jacqueline. 1990. Specifier-head agreement in Japanese. In *Proceedings of the Ninth West Coast Conference on Formal Linguistics*, 535–548. Stanford, CA: CSLI Publications. Distributed by Cambridge University Press.

- Torrego, Esther. 1995. From argumental to non-argumental pronouns: Spanish doubled reflexives. *Probus* 7, 221–241.
- Torrego, Esther. 1996. Experiencers and raising verbs. In Robert Freidin, ed., *Current issues in comparative grammar*. Dordrecht: Kluwer.
- Ura, Hiroyuki. 1994. Varieties of raising and the feature-based bare phrase structure theory. *MIT Occasional Papers in Linguistics* 7. Department of Linguistics and Philosophy, MIT.
- Ura, Hiroyuki. 1996. *Multiple feature-checking: A theory of grammatical function-splitting*. Doctoral dissertation, MIT. Distributed by MIT Working Papers in Linguistics.
- Watanabe, Akira. 1993. *Agr-based case theory and its interaction with the A-bar system*. Doctoral dissertation, MIT. Distributed by MIT Working Papers in Linguistics.
- Watanabe, Akira. 1994. A crosslinguistic perspective on Japanese nominative-genitive conversion and its implications for Japanese syntax. In Masaru Nakamura, ed., *Current topics in English and Japanese*. Tokyo: Hituzi Syobo.
- Webelhuth, Gert. 1984. German is configurational. *The Linguistic Review* 4, 203–246.
- Webelhuth, Gert. 1989. *Syntactic saturation phenomena and the modern Germanic languages*. Doctoral dissertation, University of Massachusetts, Amherst.
- Williams, Edwin. 1980. Predication. *Linguistic Inquiry* 11, 203–238.
- Vergnaud, Jean-Roger. 1985. *Dépendances et niveaux de représentations en syntaxe*. Amsterdam: John Benjamins.
- Yatsushiro, Kazuko. 1997. Structure within VP in Japanese. Paper presented at the Eighth Annual Japanese/Korean Linguistics Conference, July 25–27, Cornell University. To appear in *Japanese/Korean Linguistics* 8. Stanford, CA: CSLI Publications.
- Zaenen, Annie, Joan Maling, & Höskuldur Thráinsson. 1985. Case and grammatical functions: The Icelandic passive. *Natural Language and Linguistic Theory* 3, 441–483.
- Zwart, Jan-Wouter. 1997. Rethinking subject agreement in Swahili. Paper presented at NELS 26, Oct. 24–26, University of Toronto. To appear in the Proceedings.