

Aspects of Modality

by

Valentine Hacquard

B.A. Egyptology
University of California, Los Angeles 2000

SUBMITTED TO THE DEPARTMENT OF LINGUISTICS AND PHILOSOPHY IN
PARTIAL FULFILLMENT OF THE REQUIREMENTS FOR THE DEGREE OF

DOCTOR OF PHILOSOPHY IN LINGUISTICS
AT THE
MASSACHUSETTS INSTITUTE OF TECHNOLOGY

SEPTEMBER 2006

© 2006 Valentine Hacquard. All rights reserved.
The author hereby grants to MIT permission to reproduce
and to distribute publicly paper and electronic
copies of this thesis document in whole or in part
in any medium now known or hereafter created.

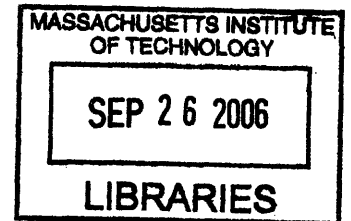

Signature of Author: _____
Department of Linguistics and Philosophy
August 15, 2006

Certified by: _____
Kai von Fintel
Professor of Linguistics
Thesis Supervisor

Certified by: _____
Irene Heim
Professor of Linguistics
Thesis Supervisor

Accepted by: _____
Irene Heim
Professor of Linguistics
Linguistics Section Head, Department of Linguistics and Philosophy

ARCHIVES

Aspects of Modality

by

Valentine Hacquard

Submitted to the Department of Linguistics and Philosophy
on August 15, 2006 in partial fulfillment of the
Requirements for the degree of PhD in Linguistics

ABSTRACT

It is a cross-linguistically robust fact that the same modal auxiliaries come in different flavors: epistemic, deontic, ability, teleological... This fact is neatly captured in a system where each modal has a single lexical entry, where the difference in flavor comes from contextually-provided accessibility relations (cf. Lewis 1973, Kratzer 1981). Equally robust, however, are the phenomena that suggest that epistemics and a subset of deontics are interpreted higher than the remaining flavors (subsumed under the label ‘root modals’). The goal of this dissertation is to show that a unified analysis of modal auxiliaries is maintainable, while still providing some principled explanation for the relative ordering of tense, aspect and the various modals in Cinque’s (1999) hierarchy, based on evidence in French and Italian.

To make sense of the relative scope of modals w.r.t. tense and aspect, I start with the empirical puzzle that aspect interacts differently with the various modal flavors. Perfective aspect on roots in French and Italian yields ‘actuality entailments’ (cf. Bhatt 1999), that is, an uncancelable inference that the proposition expressed by the complement holds in the actual world, and not merely in some possible world(s). I propose that this inference obtains when aspect scopes above the modal, and must therefore take the actual world as its world argument. Because epistemics/deontics are interpreted above aspect, they are immune to the effect.

To derive the height problem, I propose to relativize the accessibility relation of a modal to an *event*, instead of a world: the accessibility relation has a free event variable, which needs to be bound locally, either by aspect (i.e., a quantifier over events), the speech event, or an embedding attitude verb. Further selectional restrictions on the event type each accessibility relation requires limits the possible combinations of event binders and accessibility relations. The resulting binding possibilities reduce the systematic constraints on the range of a modal’s interpretations to independently-motivated syntactic assumptions on locality and movement, and explain why the various flavors of the same modal auxiliaries are interpreted at different heights.

Thesis Supervisors: Kai von Stechow, Irene Heim
Title: Professors of Linguistics

ACKNOWLEDGMENTS

This has been quite an adventure, and were it not 3 o'clock in the morning two days before I have to move, I would say that I'd do it all over again. What made it worth the while was all of the people involved in this journey, and I would like to take these few lines to thank them from the bottom of my heart.

First and foremost, the members of my committee: Irene Heim, Kai von Fintel, Sabine Iatridou and Gennaro Chierchia. All four of them are amazing linguists and people, and I am incredibly grateful to have had the chance to work with them. Irene's contribution to this dissertation and to my academic life in general is invaluable. I probably do not need to tell the world how brilliant and inspiring Irene is; the world already knows. I would like to thank her particularly for her support and her generosity with her time and ideas. I had my first semantic class with Irene, and ever since, she has always been extremely encouraging, even in my densest moments. I would not be a semanticist without her. I am also very lucky to have had Kai co-chair my committee. I have learned tremendously from him, and this dissertation has greatly benefited from his vast knowledge, his precision, his insightful ideas and his sharpening of my own ideas. I am especially indebted to him for his superhuman attempts to combat my sloppiness. I am also very grateful to Sabine, the linguist, for teaching me to pay attention to morphology and cross-linguistic generalizations, and Sabine, the person, for teaching me how important it is to create your own path. Sabine also played a key role in my finding the topic of my dissertation. I was working on the interaction of modal constructions and aspect in general, and I knew that she would not believe any proposal I would have that couldn't reconcile the various readings of modal auxiliaries. 'Fine, I thought, I'll figure out these modals and then move on'. Needless to say, I am still trying to figure them out... Finally, I am immensely indebted to the LSA summer Institute for having brought Gennaro into my academic life. Gennaro has been an invaluable source of support during the past year. Appointments with him were always inspiring and always managed to reconcile me with my thesis, no matter how mad I was at it beforehand.

I am also grateful to have had wonderful teachers at MIT: Noam Chomsky, Michel DeGraff, Suzanne Flynn, Michael Kenstowicz, Wayne O'Neil, David Pesetsky, Norvin Richards, Donca Steriade, Ken Wexler, and especially Danny Fox and Alec Marantz, who both have been an incredible source of inspiration, and have helped me become a better linguist.

I would like to thank my classmates from Ling-01, both collectively and distributively: Pranav Anand, Allison Adler, Justin Fitzpatrick, Andres Salanova, Shoichi Takahashi, and Mary Ann Walter. Ling-01 was my first family in Cambridge, and I probably would not have survived a month in grad school without them: thanks for the many tutorials in all areas of linguistics and for all the great memories.

I am also very grateful to have found a second family in Cambridge, my roommates at the Magazine St apartment: Marta Abrusan, Lauren Ashwell, Jon Gajewski, Dan Giblin, Nathan Klinedinst (for too short a while), Ivona Kucerova, Alejandro Perez-Carballo, and Michael Wagner, who've assumed at various times the roles of confidant, teacher, personal trainer, bandmate, gourmet chef, and so many more. Thanks for the good times, for the support, and for putting up with me!

Many thanks to the MIT L&P students not already mentioned above, in particular: Asaf Bachrach, Teal Bissell, Martina Gracanin, Elena Guerzoni, Sarah Hulsey, Feng-Fan Hsieh, Heather Logue, Bernard Nickel, Joey Sabbagh, Tamina Stephenson, Linnaea Stockall, Katja Vavona, and Seth Yalcin.

I have also greatly benefited from discussions with people from the greater linguistics community, in particular Rajesh Bhatt, without whose work this dissertation would not exist, Cleo Condoravdi, Bridget Copley, Martin Hackl, Michela Ippolito, Roumi Pancheva, and Barry Schein. In the spring of 2005, I spent a semester at UCLA, and I would like to take this opportunity to thank everyone there for their warm welcome. I am particularly indebted to Philippe Schlenker and Tim Stowell, for being extremely generous with their time and ideas. Last but not least, I would like to thank Dominique Sportiche, without whom I wouldn't be a linguist.

Many thanks to my Italian informants (and friends and teachers) Paolo Santorio, Maria Giavazzi, Luisa Meroni, and especially Andrea Gualmini. Many thanks to Nick Stecher for his love and support, for believing in me and reminding me, when I needed it most, that there is actually a whole world beyond possible worlds. Thanks to my family: my mother, my father, Claire, Daphné and Olympio Hacquard for their support and for serving as very patient informants. Finally, I would like to thank my grand-parents, to whom I dedicate this dissertation, Diana Tsan, Georges and Juliette Hacquard, for teaching me, through their examples and their encouragements that curiosity is not a '*vilain défaut*'. Merci!

TABLE OF CONTENTS

INTRODUCTION.....	11
CHAPTER 1: MODAL AUXILIARIES: ASPECT AND ACTUALITY ENTAILMENTS.....	29
0. INTRODUCTION.....	29
1. MODAL AUXILIARIES AND THEIR DIFFERENT INTERPRETATIONS.....	33
1.1. A Unified Account of Modal Auxiliaries.....	33
1.2. Interpretations of Modal Auxiliaries and Sensitivity to Aspect.....	37
1.3. Height of Interpretation: Syntax, Morphology and Scope.....	43
2. PROPOSAL.....	45
2.1. Assumptions: Tense and Aspect.....	46
2.1.1. Tense and world pronouns.....	46
2.1.2. Aspect.....	48
2.1.2.1. Events.....	48
2.1.2.2. Aspect.....	50
2.2. Deriving the Implicative Reading of Root Modals.....	56
2.3. Event Identification Across Worlds.....	57
2.4. Interaction with Negation.....	63
2.5. Is the Modality Detectable?.....	64
2.5.1. The Case of Goal-Oriented Modality.....	64
2.5.2. Root Modals and Implicatures.....	67
3. PREVIOUS PROPOSALS.....	68
3.1. Bhatt (1999).....	68
3.2. Piñón (2003).....	71
4. CONCLUSION AND LOOK-AHEAD.....	72
CHAPTER 2: IMPERFECTIVE AND NON IMPLICATIVE READINGS OF ROOT MODALS.....	73
0. INTRODUCTION.....	73
1. NON IMPLICATIVE READINGS OF ROOTS: ABILITIES VS. COUNTERFACTUAL SITUATIONS.....	75
2. DIFFERENT USES OF THE IMPERFECTIVE (<i>IMPARFAIT</i>).....	78
2.1. Characteristics of the Imperfective.....	78
2.2. Durative Uses.....	80
2.3. Counterfactual uses.....	82
2.3.1. Counterfactual Conditionals.....	82
2.3.2. Imperfect Conditionals.....	83
2.3.3. Other Modal Uses?.....	84
3. PROPOSAL FOR THE IMPERFECTIVE.....	86
3.1. Different Aspectual Operators.....	86
3.1.1. Hab/Prog.....	87

3.1.2. GEN.....	89
3.1.3. Counterfactuality.....	92
3.1.3.1. <i>A Counterfactual Modal</i>	92
3.1.3.2. <i>Past</i>	96
3.1.3.3. <i>Future and Modality</i>	97
3.2. Morphological Spell-out.....	98
3.2.1. Statives.....	100
3.2.2. An Alternative Spell-out Condition.....	101
3.2.3. Epistemics and Aspect.....	102
3.2.4. Counterfactuals: <i>Conditionnel vs. Imperfective</i>	102
4. NON IMPLICATIVE READINGS OF ROOT MODALS.....	103
4.1. Deriving the Ability Reading.....	103
4.2. Deriving the Counterfactual Meaning.....	105
4.3. Other ‘Imperfective’ Operators on Root Modals?.....	106
5. CONCLUSION.....	108
APPENDIX A – THE PRESENT TENSE.....	109
CHAPTER 3: EPISTEMICS/DEONTICS VS. ROOTS: A HEIGHT PROBLEM.....	113
0. INTRODUCTION.....	113
1. BUILDING BLOCKS FROM CHAPTER 1.....	117
2. SETTING APART EPISTEMICS VS. ROOT MODALS.....	118
2.1. Quantifiers and Scope.....	118
2.2. Expletives/Idiom Chunks.....	119
2.3. Negation.....	119
2.4. Tense.....	120
2.5. Speaker vs. Subject Relativity.....	123
3. PREVIOUS PROPOSALS.....	125
3.1. Brennan (1993).....	126
3.2. Issues of Raising vs. Control.....	128
4. PROPOSAL.....	131
4.1. Binding Possibilities of the Accessibility Relation’s Event Variable....	132
4.2. Accessibility Relations.....	136
4.2.1. Epistemics.....	136
4.2.1.1. <i>Attitude Verbs</i>	137
4.2.1.2. <i>Speech Event</i>	141
4.2.2. Circumstantial accessibility relation.....	145
4.2.3. Deontics.....	147
4.3. Restrictions on the Type of Accessibility Relations.....	150
4.3.1. Restrictions on a Deontic Accessibility Relation.....	150
4.3.2. Restrictions on a circumstantial accessibility relation.....	151
4.3.3. Restrictions on an epistemic accessibility relation.....	155
4.4. Taking Stock of Scope Issues – Epistemics/Deontics vs. Roots.....	157

4.5. Interaction of Tense, Modals, and Counterfactuality.....	159
5. CONCLUSION.....	161
CHAPTER 4: ITALIAN VOLERE (WANT) AS AN ATTITUDE-MODAL HYBRID.....	163
0. INTRODUCTION.....	163
1. SEMANTICS OF WANT, VOULOIR, VOLERE.....	167
1.1. Semantics for <i>want</i>	167
1.2. <i>Volere</i>	171
2. RESTRUCTURING PROPERTIES OF VOLERE.....	175
2.1. <i>volere</i> vs. <i>vouloir</i> : syntactic differences.....	175
2.2. The Monoclausal Approach to Restructuring.....	176
2.3. Aspect Movement as a Transparency Effect.....	178
3. IN DEFENSE OF THE SINGE EVENT QUANTIFICATION VIEW.....	180
3.1. <i>volere</i> and <i>again</i>	182
3.2. <i>again</i>	183
3.3. French vs. Italian perfective <i>want</i>	188
3.4. Imperfective <i>volere</i> , <i>again</i>	190
4. CONCLUSION.....	191
CONCLUSION.....	193

INTRODUCTION

A unique feature of human language is what Charles Hockett called ‘displacement’: our ability to talk about things beyond the here and now. The way we do so is through the Tense, Aspect and Modality systems of natural language. Roughly speaking, *Tense* places events on a time continuum; *Aspect* deals with durational properties of these events; *Modality* allows us to talk about events that may not have happened, but are desired or required. These three systems are not completely autonomous units, and they affect one another in non trivial ways. Tense and Modality are undeniably interconnected: what used to be a possibility a month ago may not be one today. Tense and Aspect are likewise related: a punctual event that took place yesterday may not hold at present, but an event (or state) that is more durative may still hold. This dissertation focuses on the perhaps less-studied interaction of Aspect and Modality. As we will see, they sometimes interact in ways that simply cannot leave either party unaffected.

The primary function of modal words is to enable us to talk about possibilities and necessities. We can talk about the ways the world *should* be, were there peace on Earth, how it *might* have been, would Christopher Columbus not have landed in America, etc... This ability to go beyond directly observable facts is indeed at the heart of the meaning of modal expressions, and is neatly captured formally by invoking the notion of ‘possible worlds’ (cf. Kripke 1963, Lewis 1973, Kratzer 1981, 1991, a. o.). There is a multitude of ways the world could be, and each possible world represents a different variant, a different *state of affairs*, if you will. I could have 100,000 hairs, or 100,001. There are then many pairs of possible worlds which are completely identical to one another, but differ in that in one of them I have 100,000 hairs, and in the other 100,001. To take another example, there are some worlds in which I am always right, and then again, there are many more where I am not. What modal auxiliaries do is ‘quantify’ over different sets of worlds, the way the quantifiers *some* or *every* quantify over sets of individuals. Thus, a sentence like ‘*Jane must go to bed at 9:00pm*’ states that in all accessible worlds among a certain set (e.g., in all of the possible worlds in which Jane’s parents’ orders are obeyed), Jane goes to bed at 9:00. The *necessity* part of the meaning comes from the fact that the sentence is universally quantified: Jane goes to bed at 9:00 not just in some but in *all* of the worlds in which she obeys her parents. A possibility is obtained by quantifying over *some* accessible world: ‘*Jane may watch TV*’ means that there is (at least) a world in which Jane

watches TV and still obeys her parents. Note that in both of these cases the *actual* world is not necessarily one of the accessible worlds: sadly for her parents, Jane may be a very disobedient girl in reality, and hence never go to bed at 9:00. However, we still judge the sentence to be true.

We thus see that modal words enable us to talk about non actual (but possible) situations by invoking worlds other than the actual one. The actual world may, of course, be one of the accessible worlds: this happens when the accessibility relation (i.e., the selection function which determines which worlds are being quantified over) is *reflexive*. An accessibility relation relates a world of evaluation (the actual world in an unembedded—or matrix—context) to a set of (accessible) worlds in which certain propositions hold. With a reflexive accessibility relation, the world of evaluation is one of the accessible worlds. This is the case with an epistemic accessibility relation, which picks a set of worlds compatible with what we know in the world of evaluation. Because an epistemic relation is reflexive, in an epistemic statement such as ‘*in view of the evidence, Jane may be the murderer*’, the actual world is one of the accessible worlds (that is, the actual world is one of the worlds compatible with my evidence in the actual world). Crucially, however, the actual world itself doesn’t have to be a world in which the complement holds: the sentence will be true if the complement is true in one of the accessible worlds, but because it doesn’t have to be true in all accessible worlds (*may* existentially quantifies over accessible worlds), it doesn’t have to be true in the actual world. The sentence is true if Jane turns out not to be the murderer in reality. Put it another way, ‘*Jane may be the murderer and Elisabeth may be the murderer*’ is not a contradiction: there is a world compatible with my evidence in which Jane is the murderer and a world compatible with the same evidence as well in which Elisabeth is the murderer (the actual world could be either one these worlds or neither one of them).

This feature of quantification over possible worlds is a very powerful and desirable one to handle a wide variety of cases. However, as it stands, it offers very little means to derive an explanation for the puzzle I am about to describe.

As first discovered for the ability modal by Bhatt (1999), in certain languages (like French), certain modal constructions require their complement to hold in the actual world, and

not merely in *some* possible world. However this requirement obtains *only* when the modals are marked with perfective aspect. Consider the following example¹:

- (1) a. Pour aller au zoo, Jane pouvait prendre le train.
To go to the zoo, Jane can-past-impf take the train
- b. Pour aller au zoo, Jane a pu prendre le train.
To go to the zoo, Jane can-past-pfv take the train

The truth conditions of (1)a) are equivalent to its English translation: there is a world among all accessible worlds in which Jane goes to the zoo where she took the train to get there. This is compatible with a scenario in which Jane did not take the train in reality (nor went to the zoo, for that matter). Things are different with (1)b): for the sentence to be true, Jane must have taken the train *in the actual world*. Any continuation stating that she, in fact, did not take the train, will come out as a contradiction. I will follow Bhatt's terminology in calling this effect of having the complement being forced to hold in the actual world, an 'actuality entailment'. As we will see in section 2, we are dealing here with an entailment rather than an implicature: the implication that the complement holds in the actual world cannot be cancelled.

Importantly, the effect can only be seen in languages that have an overt aspectual distinction such as French, Italian, Catalan, Bulgarian, Greek, Hindi.² Because English doesn't distinguish between the two aspects, the actuality entailment goes undetected. To get a feel for the data in English, the following examples involving the predicate *able* help bring about, via temporal adverbials, the perfective meaning (and hence, an implicative interpretation) in (a) and the imperfective one (and hence, a non implicative interpretation) in (b):

- (2) a. Yesterday, firemen were able to eat 50 apples. [Bhatt (1999)]
b. Back in the days, firemen were able to eat 50 apples.

Turning back to our French examples, the overt difference between (1)a) and (1)b) is the aspectual morphology on the modal: the former shows imperfective (*imparfait*) and the latter

¹ The modality involved here is goal-oriented modality (cf. von Stechow and Iatridou 2005), and not a pure ability modal, which was the modal interpretation Bhatt (1999) discusses. We will turn shortly to the difference in meaning between the various flavors of modality.

² Interestingly, Albanian, Basque, Galician, Brazilian Portuguese, and Spanish seem to have an extra counterfactual reading with perfective aspect (cf. Bhatt 1999, Bhatt and Pancheva 2005, Brogionovo and Cummins 2006). For reasons of space, I will put this issue aside, as the bulk of my data will be in French and Italian.

perfective (*passé composé*) aspect. At the descriptive level, it appears then that perfective somehow neutralizes the modality and forces the complement to hold in the actual world. But this is puzzling in at least two respects. First, why should there be a difference in ‘actuality entailment’ between perfective and imperfective? Both are using the same modal in the same sense (we are presumably dealing here with a circumstantial modal, restricted by a purpose clause). Whatever the meaning of one, we would expect the other to vary along an aspectual/point of view dimension, and not a modal one. The second issue is that the modal involved looks like the archetypal possibility modal (at least based on its other usages when we give it a deontic or an epistemic interpretation). All that ((1)b) should say is that there was *some* accessible world (i.e., some possibility) in which he took the train: how can we force this world to be the actual one?

Finally, note that the actuality entailment pattern is found again with the universal counterpart of (1):

- (3) a. Pour aller au zoo, Jane devait prendre le train.
 To go to the zoo, Jane must-past-impf take the train
- b. Pour aller au zoo, Jane a dû prendre le train.
 To go to the zoo, Jane must-past-pfv take the train

Here again, perfective morphology in (3)b) forces the complement to hold in the actual world, while the corresponding sentence with imperfective in (3)a) imposes no such restriction. ((1)b) and ((3)b) are both true in situations where Jane actually took the train and went to the zoo and false in situations where she didn’t take the train. However, the two are not interchangeable: one is a (actualized) possibility, the other, a (actualized) necessity. With the latter, taking the train was the only possible option. With the former, other options might have been available, and we get the further impression that taking the train was Jane’s *preferred* way to get to the zoo.

One of the main questions that this dissertation addresses is how to derive these actuality entailments. What is responsible for the apparent eradication of the very property of ‘displacement’ that defines modals? Is this a pragmatic effect or does it fall out of particulars of the syntax and semantics of aspect and modality? What then would be the semantics of aspect and modality such that actuality entailments arise in certain environments and not others? Which

modal constructions are sensitive to aspect and yield actuality entailments, and which do not? For those that do not yield actuality entailments, what makes them immune to this effect?

This dissertation focuses primarily on modal auxiliaries in French and Italian. As we will see, certain interpretations of these modal auxiliaries (e.g., abilities) yield actuality entailments with perfective aspect, while others (e.g., epistemics) do not. Why should there be such a split? As it turns out, this split correlates with the traditional ‘epistemic’ vs. ‘root’ distinction, which has been shown to be sensitive to other semantic and syntactic phenomena. Thus, the more general goal of the dissertation will be to provide a better understanding of what sets these two classes apart, in light of the new empirical facts and theoretical implications provided by the actuality entailment pattern.

Before we start, however, I would like to eliminate what I feel is a non-starter, right off the bat. There is one technical trick that could derive actuality entailments such as the ones in (1) and (3). This trick would involve restricting the domain of quantification to only one world: if the accessibility relation is reflexive and furthermore only picks one world, and in that world the complement holds, then necessarily, the complement will hold in the actual world. A good candidate for such an accessibility relation is Kratzer’s ‘totally realistic’ conversational background³ (*in view of what is the case...*), which does exactly this by depicting the actual world in such detailed way that it uniquely describes it. Putting aside skepticism about the existence of such an accessibility relation (e.g., what is the difference between this kind of modality and no modality at all?), we still cannot get it to work. We can use (1a) and ((1)b) against the same conversational background: we are talking about Jane wanting to go to the zoo and the options available to her at that time, etc... Why would the version with perfective aspect force a totally realistic conversational background, and the one with imperfective not? We could stipulate that this is precisely what perfective aspect does: it indicates/forces a totally realistic conversational background. But as we will see shortly, perfective doesn’t always yield an actuality entailment in modal constructions. Furthermore, such a solution would predict that all modal constructions with perfective aspect have the same conversational background: they would all be evaluated in view of what is the case. But that cannot be right. Finally, consider the difference between the actuality entailments derived with the possibility modal *pouvoir* and the necessity one *devoir*. While a totally realistic conversational background may not be required for

³ In Kratzer’s system, a conversational background is, roughly speaking, an accessibility relation.

the actuality entailment to go through, given that we have universal quantification (as long as the modal base is reflexive and there is no ordering source⁴), we would still lack an explanation for the difference between the two aspects. Invoking our trick that perfective aspect correlates with a totally realistic conversational background would raise the further question of what the meaning difference is between (1)b) and (3)b). Because a totally realistic accessibility relation only picks out one world, namely the base world (the actual world in matrix contexts), there shouldn't be any difference in meaning between universal and existential quantification.

1. ACTUALITY ENTAILMENT OR ACTUALITY IMPLICATURE?

A first gut reaction to the actuality entailment behavior of modals is that we are dealing with a strong implicature rather than an entailment. If this were the case, it would allow us to keep our semantics for aspect and modality without modification and derive the implicature through some pragmatic reasoning (along the line of a competition effect between imperfective and perfective, which we will pursue below). We would then expect to be able to cancel such an implicature in certain environments. However, we cannot. There is, however, a class of predicates that seem to yield an actuality *implicature* as opposed to an entailment, in the sense that it can be cancelled:

- (4) a. Darcy a eu la possibilité de rencontrer Lizzie.
Darcy had-pfv the possibility to meet Lizzie
- b. Darcy avait la possibilité de rencontrer Lizzie.
Darcy had-impf the possibility to meet Lizzie

Out of the blue, (4)a) implies (especially in contrast with (4)b)) that Darcy did meet Lizzie. However, a continuation stating that he didn't meet her doesn't come as a contradiction. Interestingly, the meaning of (4) is extremely close to what we would get, were we to replace *avoir la possibilité (have the possibility)* by modal *pouvoir (can)*. And yet, the latter yields an actuality entailment, while the former only an implicature. This fact strongly suggests that something in the syntax/semantics of the modal, rather than some pragmatic factor linked to a possibility meaning is responsible for the actuality entailment.

⁴ As we will see in chapter 2, in Kratzer's system, a modal is restricted by two conversational backgrounds. A first conversational background gives you the worlds of the modal base (the accessible worlds). The ordering source is a second conversational background whose role is to order the worlds of the modal base according to some contextual ranking. For instance, a necessity modal with a circumstantial modal base and a deontic ordering source will mean roughly that the complement holds in all the circumstantially accessible worlds closest to an ideal given by the law.

In this section, I will show how to derive an actuality implicature with predicates like *have the possibility*, given standard semantics for aspect, and some pragmatic reasoning. We will see that such an account is impossible for our modal auxiliaries, and deduce that the key to the actuality entailment puzzle is rooted in the syntax and semantics of the modals, and cannot be derived in the pragmatics alone.

1.1. THE ROLE OF ASPECT

We will first go over standard semantics of perfective and imperfective aspect, and show why, given these semantics, we cannot derive an actuality entailment by combining perfective with the relevant modal constructions. The semantic contribution of aspect is to relate the time of the event to that of a reference time, itself provided by tense (whose own contribution is to locate this reference time with respect to the utterance time). By no means are the semantics of aspect a settled matter. For instance, it is not clear whether we can have a unified treatment of the imperfective, covering all of its different uses, including progressive, habituals and counterfactuals. We will address this question in chapter 2.

However, there is some consensus in the aspect literature that imperfective refers to an ongoing/incomplete event, while perfective denotes a punctual/culminating event. A classic implementation of this intuition is to have the imperfective have its reference time be included within the event time, while the perfective has the event time included within the reference time (Klein 1994; the following lexical entries are from Bhatt and Pancheva 2005). Each aspect morpheme takes a predicate of events and a time argument and relates the time of the event with respect to the reference time:

- (5) a. $[[\text{IMPERFECTIVE}]] = \lambda P. \lambda t. \exists e [t \subseteq \tau(e) \ \& \ P(e)]$
 b. $[[\text{PERFECTIVE}]] = \lambda P. \lambda t. \exists e [\tau(e) \subseteq t \ \& \ P(e)]$

The following example illustrates with a telic event (putting aside, for now, the modal element argued to be involved in progressive and habituals):

- (6) a. Jane arrivait (quand je l'ai vue/à 9h00 tous les matins).
 Jane arrive-impf (when I saw her/at 9am every morning)
 $\exists e [t \subseteq \tau(e) \ \& \ J. \text{ arrive}(e)]$

- b. Jane est arrivée (à 9h00).
 Jane arrived-pfv (at 9am)
 $\exists e[\tau(e) \subseteq t \ \& \ J. \ arrive(e)]$

In general, imperfective is odd out of the blue and requires a temporal anchor. In (6)a), we either have a progressive reading (brought about by the when clause) or a habitual (brought about by ‘*every morning*’). With perfective, the time of the arriving event is contained within the reference time (9:00am), whereas with imperfective, the arriving event surrounds the reference time.

With an activity predicate, the imperfective entails the perfective version of that predicate. This is easily achieved with the above semantics, with a further assumption that activity predicates have the subinterval property (a subinterval of a P-event is also a P-event):

- (7) a. Jane courrait.
 Jane run-impf
 $\exists e[t \subset \tau(e) \ \& \ J. \ run(e)]$
- b. Jane a couru.
 Jane run-pfv
 $\exists e[\tau(e) \subseteq t \ \& \ J. \ run(e)]$

In (7)a) the running event surrounds the reference time, while it is included in the reference time in the perfective version. Given that a subinterval of a running event is a running event, we can see that the former entails the other. In this case, the imperfective is logically stronger than the perfective, which is the sort of situation that fosters Gricean reasoning involved in implicatures. Musan (1995), for instance, uses such a strategy to derive the ‘lifetime effects’ associated with past tense (in contrast to present tense), in sentences such as ‘*Jane had blue eyes*’: the present is logically stronger than the past, thus if the speaker chooses the weaker past, the hearer will understand that the speaker is not in a position to assert the present version, thus will infer that the present ‘*Jane has blue eyes*’ doesn’t hold, and deduce that the reason why Jane doesn’t have blue eyes anymore (a permanent property), is that Jane is no longer with us.

Back to our aspect cases. What happens with statives predicates? Consider the following example, involving an individual-level predicate:

- (8) a. Cette maison faisait 15 mètres de haut.
 This house was-impf 15 meters high
 $\exists s[t \subset \tau(s) \ \& \ this-house-15m(s)]$ [s=state]

- b. Cette maison a fait 15 mètres de haut.
 This house was-pfv 15 meters high
 $\exists s[\tau(s) \subseteq t \ \& \ \text{this-house-15m}(s)]$

In ((8)b) we get a strong implication that the house is not 15 meters high anymore, that it somehow got destroyed, or that the top story got chopped off. No such implication happens with the imperfective: ((8)a) can be part of a narrative, where one is describing a house. Is this implication an implicature and can we derive it, given our semantics?

We saw with activity predicates that, as long as an event has the subinterval property (which a state of course has as well), the imperfective is logically stronger than the perfective version. A Gricean reasoning would go as follows: when two competitors stand in an asymmetric entailment relation, and the speaker asserts the weaker competitor, we assume that the speaker is not in a position to assert the stronger statement. In the case at hand, the imperfective is stronger than the perfective. If a speaker asserts the (weaker) perfective version, we take it that he is in no position to assert whether the state of being 15 meters high extends beyond the reference time. We can thus derive an implicature that it doesn't extend beyond the reference time. If a state doesn't hold after a salient past time, and given the permanence of states such as height for buildings, we can see why we get the impression that the building has been irremediably altered.

A similar account can derive the following example:

- (9) a. Cette voiture a coûté 25.000 dollars.
 This car cost-pfv 25,000 dollars
 b. Cette voiture coûtait 25.000 dollars.
 This car cost-impf 25,000 dollars

With the perfective, we get an implication that I actually bought the car, whereas no such implication arises with imperfective.⁵ Applying a similar reasoning, we can see that the state of costing \$25,000 doesn't hold anymore. How could the state of costing \$25,000 not hold anymore? If we assume that an object stops *costing* a certain amount of money when it is not for sale anymore, then we can derive that a selling transaction took place and hence that the car got bought. Note however that another way something stop costing a certain price is when the price itself changes (in that sense, costing x-amount of dollars is a less permanent state as being 15

⁵ Thanks to J. Fitzpatrick for pointing this fact to me.

meters high). This reading can be brought out in a context where the price of the car fluctuates, because of the market instability. In that case, the inference that I bought the car disappears:

- (10) Les prix n'ont pas arrêtés de fluctuer. Hier, cette voiture a (même) coûté 25.000 dollars.
Prices have been going up and down. Yesterday, this car (even) cost-pfv 25000\$

We see that we can get some mileage by reasoning about why a state doesn't hold beyond a certain point. We will try to use such reasoning for our actuality entailment/implicature puzzle.⁶

1.2. ASPECT COMPETITION EFFECTS AND PRAGMATIC REASONING

We have seen how one can derive certain implicatures, which are not directly asserted, by reasoning about the meaning of the perfective vs. the imperfective, when combined with a stative predicate. As modals are traditionally taken to be stative predicates, we might hope that such reasoning would derive some implicatures, and in fact, it looks like this is how *have the possibility* works. Recall that in the following example, we get an implicature that the complement took place, and that this implicature can be cancelled:

- (11) a. Jane a eu la possibilité de rencontrer Lizzie.
Jane had-pfv the possibility to meet Lizzie
b. Jane avait la possibilité de rencontrer Lizzie.
Jane had-impf the possibility to meet Lizzie

As a starting point, we will assume that 'having the possibility to meet Lizzie' is a state or a process, at least in its underlying meaning, as it passes the classic *in an hour/for an hour* telicity test (the former being grammatical only with telic events, the latter with atelic):

⁶ For reasons not well understood, a combination of perfective with statives in some languages (e.g., Modern Greek), doesn't yield an implication that the state doesn't hold anymore, but rather that the state *begins* to hold at the time of reference (this is the so-called *inchoative*):

- (i) χθες ton ayapisa. [from Bhatt and Pancheva (2005)]
yesterday him love-past-pfv
Yesterday, I fell in love with him

Assuming that perfective talks about a punctual event, we could make the leap that the point in question is the *starting* point of the loving event. However, it remains a mystery why it is that, in some languages (like French), we get an inference that the state stopped holding and in others (like Greek) that the state started. I simply note the problem here and leave it aside for future research.

- (12) a. Pendant une heure, Jane a eu la possibilité de rencontrer Lizzie.
For an hour, Jane had-pfv the possibility to meet Lizzie
- b. ?En une heure, Jane a eu la possibilité de rencontrer Lizzie.
In an hour, Jane had-pfv the possibility to meet Lizzie

Note that with the *in* adverbial, perfective morphology is possible, while a bit more marked, and yields a sort of inchoative meaning (Jane *acquired* the possibility to meet Lizzie).

Applying our semantics for perfective, we take it that the possibility doesn't hold after the reference time. When does a possibility stop being a possibility? There are really only two ways: the first one is when the circumstances change in some irremediable way: if one doesn't act on time and the circumstances change, then the possibility is not available anymore. The second way is for the complement to have taken place. To make this intuition clearer, imagine a once in a lifetime sort of event like *eating sushi for the first time*. If Jane had the possibility to eat sushi for the first time at some point and doesn't have that possibility anymore, it either means that she did eat sushi for the first time (the possibility to eat it for the first time is gone forever), or that the circumstances changed in some other irremediable way (e.g., all fish went extinct).

This explains how we sometimes get the inference that the complement took place, and why we sometimes do not (sometimes the possibility disappears because it was realized, sometimes because the circumstances held for too short a while). A reasoning account seems quite simple and successful. However, it cannot be the whole story for our modal auxiliaries, where the actuality entailment is simply not cancelable. Let's consider the ability modal (which we will see is one of the interpretations that yields actuality entailments), as way of illustration:

- (13) a. Jane a pu soulever cette table, #mais elle ne l'a pas soulevée.
Jane could-pfv lift this table, #but she didn't lift it
- b. Jane pouvait soulever cette table, mais elle ne l'a pas soulevée.
Jane could-impf lift this table, but she didn't lift it

Assuming that ability *can* is at base stative (abilities are after all relatively long lasting), we will derive here as well that Jane had a certain ability during the reference time, but that this ability ceased to hold beyond the reference time for the case of the perfective. How could one cease to have an ability? One's own physical and mental properties could perhaps deteriorate: when Jane was younger she was able to run 3 miles, but she got out of shape and can no longer

do it. It could also be that the circumstances change: she may have been able to lift this table, until a 40 lbs monkey sat on it. Contrary to our ‘possibility’ case, however, it isn’t the case that realizing an ability annihilates that ability: If Jane was able to lift this table and lifted it, then, everything else being equal, she still has the ability to lift it.

It may well be that we need an alternative pragmatic reasoning account. One such account, suggested by Gennaro Chierchia (p.c.), would go along these lines: how could the speaker know that the subject had a certain ability, if not by witnessing its actualization. The hearer would thus make the extra step of inferring that the speaker witnessed the subject actualize his ability. However, once we control for very specific contexts where we have ample evidence that the subject had a certain ability without necessitating the actualization of the ability at that particular time, the entailment still goes through:

- (14) Pendant l’entraînement, Jane a soulevé des poids de 200kg plusieurs fois d’affilée sans aucun problème et donc lors de la compétition, elle a pu soulever un poids de 150kg, #mais elle n’a soulevé que le poids de 100kg.
During training, Jane lifted 200kg weights several times in a row without any problem, thus during the competition, she could-pfv lift a 150kg weight, #but she only lifted a 100kg weight.

It thus appears that we cannot invoke the type of reasoning we used for ‘*having the possibility*’. Moreover, even if we were able to find such a reasoning, we should have the option to tweak the context in a way that could cancel an actuality implication, in order to accommodate a continuation that denies that the complement took place (as in the case of *have the possibility*). But that is not possible. It would seem unreasonable to alter the lexical meanings of perfective, by adding a stipulation that it has some sort of an actualization feature: we want to have the flexibility to implicate actualization for certain predicates, but still be able to cancel it. Furthermore, as we will see in the next section, not all modal constructions yield an actuality entailment with perfective. Thus, it appears that the key to the actualization entailment problem needs to be found within the syntax and semantics of those modal constructions themselves.

2. EPISTEMIC VS ROOT INTERPRETATIONS: A SPLIT IN IMPLICATIVE BEHAVIOR

The actuality entailment puzzle is two-fold. First, we would like to know how it comes about: we have seen that it cannot be a pure pragmatic effect, and that something structural seems to be at

the root of the problem. Secondly, not *all* interpretations of the *same* modal auxiliaries yield actuality entailments with perfective. This section surveys the various interpretations that modal auxiliaries get and show which yield actuality entailments, and which do not.

The actuality entailment effect was first discovered by Bhatt (1999) for the ability modal. Bhatt showed that its implicative behavior correlates with the aspect modifying it, in languages that have an overt morphological distinction. The following example illustrates:

- (15) a. Jane a pu soulever cette table, #mais elle ne l'a pas soulevée.
Jane could-pfv lift this table, #but she didn't lift it
- b. Jane pouvait soulever cette table, mais elle ne l'a pas soulevée.
Jane could-impf lift this table, but she didn't lift it

The ability modal in (15)b) relates a mere ability to Jane, namely that of having been able to lift this table, without any implication of whether she actually lifted it or not. ((15)a) on the other hand entails that Jane actually lifted the table: it isn't possible to continue the sentence with something that would deny the complement clause.

We saw at the beginning of this Introduction other instances of modal auxiliaries which yielded actuality entailments. These examples are repeated below. The flavor of modality in these examples has been called 'goal-oriented' (cf. von Stechow and Iatridou 2005). A goal-oriented modal quantifies over worlds in which certain facts/circumstances of the base world hold and in which the subject reaches her goal (e.g., that of going to the zoo):

- (16) a. Pour aller au zoo, Jane pouvait prendre le train.
To go to the zoo, Jane can-past-impf take the train
- b. Pour aller au zoo, Jane a pu prendre le train.
To go to the zoo, Jane can-past-pfv take the train
- (17) a. Pour aller au zoo, Jane devait prendre le train.
To go to the zoo, Jane must-past-impf take the train
- b. Pour aller au zoo, Jane a dû prendre le train.
To go to the zoo, Jane must-past-pfv take the train

Not all interpretations of the same modal auxiliaries yield actuality entailments, however, and in that sense are more 'well-behaved' modals. An epistemic interpretation is not affected by perfective aspect. Consider the following example:

- (18) a. Darcy a dû aimer Lizzie.
Darcy must-pfv love Lizzie
'Darcy must have loved Lizzie.'
- b. Darcy devait aimer Lizzie.
Darcy must-impf love Lizzie
'Darcy must have been in love with Lizzie'.
- (19) a. Darcy a pu aimer Lizzie.
Darcy could-pfv love Lizzie
'Darcy could have loved Lizzie.'
- b. Darcy pouvait aimer Lizzie.
Darcy could-impf love Lizzie
'Darcy could have been in love with Lizzie'.

There is no difference in actuality entailment between ((18)a) and ((18)b): in both cases the speaker asserts to the best of his knowledge *at the time of utterance* what must have been the case (at a salient past time). The contribution of aspect is interpreted *below* the modal. In ((18)a) the state of Darcy loving Lizzie held at some point in the past, with an implication that it doesn't hold anymore, while in ((18)b) the state of Darcy loving Lizzie could still hold at utterance time.

We thus have goal-oriented and ability interpretations on the one hand, and epistemics on the other. Another classic interpretation we need to look at is deontics (i.e., having to do with permissions and obligations). As we will see in chapter 1, deontics split into two categories: addressee-oriented deontics (where the obligation is put on the *addressee*) and subject-oriented deontics (where the obligation is on the subject). The former pattern with epistemics and do not yield actuality entailments, and in fact, are ungrammatical with perfective aspect. The latter pattern with goal-oriented modals: they yield actuality entailments with perfective.

Thus the modal auxiliaries interpretations that yield actuality entailments include the ability, the subject-oriented deontic and the goal-oriented ones. We will see that what these interpretations have in common is that they all involve a *circumstantial* accessibility relation (which restricts the set of accessible worlds to those in which certain circumstances of the base world hold). We will refer to this group as 'root' interpretations. The epistemics and addressee-oriented (true) deontics, on the other hand, do not yield actuality entailments.

Interestingly, this epistemics/deontics vs. roots split is rather pervasive across a series of semantic and syntactic phenomena which all suggest that the former are interpreted higher than the latter. For instance, epistemics/true deontics seem to scope above Tense, while roots seem to

scope below it. We will further see that epistemics/true deontics seem to be keyed to a participant of the speech event (either the speaker, or the addressee), while abilities and goal-oriented interpretations seem to be keyed to a participant of the main event. In French, the sentence below is ambiguous between an epistemic reading and a goal-oriented one. With the epistemic reading, the time of evaluation of the modal is the speech time (*now*), and the epistemic state reported is that of the speaker. With the goal-oriented interpretation, the time of evaluation of the modal is the time provided by Tense (*then*), and the circumstances reported are that of the subject:

- (20) Jane a dû prendre le train.
Jane must-pst-pfv take the train
Epistemic: Given my evidence **now**, it must be the case that Jane took the train then.
Goal-oriented: Given J.'s circumstances **then**, she had to take the train then.

As we will see in chapter 3, these constraints on the range of interpretations (coupled with the difference in implicative behavior) are unexpected under the view that we are dealing with the same modal, but where the difference in flavor (epistemic vs. circumstantial) is due to context, as in any account in the Kratzerian tradition. In fact, because the generalization that epistemics/deontics are high and roots are low is so robust, it has been proposed that they really are not the same modals. In his famous hierarchy, Cinque (1999) proposes that the ordering of Tense, Aspect and the various modals is fixed. Thus, if epistemics scope above Tense, it is simply because this is the position where they are merged. However, while, descriptively, it is more than adequate, it lacks in explanatory force. Why should these heads be organized the way they are? Is there some deep conceptual reason? Others have proposed to explain the 'height' of interpretation problem in terms of types: epistemics will take propositions, while roots will take properties (cf. Brennan 1993, Butler 2004). But again, why couldn't an epistemic modal take a property as its complement? And why, if we are dealing with two separate modals, do we find that the same lexical items are used, in language after language?

The ultimate goal of this dissertation will be to try to show that a unified account of modal auxiliaries is maintainable. Towards this end, I will propose to amend a few amendments to Kratzer's system, in ways that will reduce the height problem and the systematic constraints on the range of a modal's interpretations to independently-motivated syntactic assumptions on locality and movement.

3. OUTLINE OF THE DISSERTATION

In the remainder of this Introduction, I will briefly go over the different chapters of this dissertation. Chapter 1-3 are devoted to auxiliary modals in French and Italian. In **Chapter 1**, I show that the interpretations of these auxiliaries which yield actuality entailments are the ‘root’ modals, that is, those with a circumstantial modal base (cf. Krazter 1991). I further show that this split correlates with the height of interpretation of the modal w.r.t. aspect: the interpretations immune to actuality entailments are interpreted *above* aspect. This suggests that root modals yield actuality entailment because they scope *under* aspect. In my system, aspects are quantifiers over events, which get base-generated as an argument of the verb. Just like generalized quantifiers in object position, they have to move out for type reasons. This movement targets a right below tense, so that aspect can combine with its time argument. Aspect will thus move *above* a root modal, merged in a position below T. Given that aspects have a world argument in their restriction, this movement will prevent that world argument to be bound by the root modal, and thus it will have to default to the actual world: we will then obtain an actual event.

Chapter 2 is devoted to imperfective aspect, and how to derive the non implicative readings of root modals, associated with imperfective. Imperfective is in general associated with many readings, many of which seem to involve some kind of modality. However, it has proved very difficult to find a unified semantics of the imperfective that would cover all of its uses. I propose a way to make sense of the distribution of the imperfective, by arguing that it is a default morpheme, which appears in the environments in which perfective cannot. The semantic work is done by some modal or aspectual operators. I will argue that it is these modal elements which are responsible for the lack of actuality entailments associated with imperfective in root modals.

In **Chapter 3**, I propose a way to derive the split between epistemic and root modals via a combination of syntactic and semantic factors. I first show that the interpretations of the modal auxiliaries seem to always be keyed to a time and an individual. I propose to encode this dependency by having the modal’s accessibility relation take an *event* argument, rather than a world. The information about the individual and the time will be recoverable via the agent and temporal trace of the event. When this event variable is bound by the speech event, it will yield an interpretation keyed to a participant of the speech event (Speaker or addressee) and to the time of that event (the speech time). When it is bound by the aspect, originating from the complement

clause, it will be keyed to the participants of the event quantified by Aspect (the subject, and sometimes the location), and to the time of that event (the time provided by Tense). I will then try to show why a speech event-bound modal gets linked to an epistemic or a deontic accessibility relation, and why an aspect-bound modal gets linked to a circumstantial one, based on selectional restrictions on the type of event that these accessibility relations require. For instance, an epistemic relation will need to be bound by a state or an event that has ‘content’. As we will see, only attitudes and the speech event have content (e.g., the content of a belief state will be the set of beliefs that its experiencer has).

Chapter 4 will be devoted to the Italian predicate *volere* (*want*), which seems to share traits both with attitude verbs and root modals. Interestingly, *volere* (in (a) below), unlike its French counterpart *vouloir* (in (b) below) shows the same implicative behavior as root modals with perfective aspect:

- (21) a. Darcy ha voluto parlare a Lizzie, #ma non gli ha parlato.
b. Darcy a voulu parler à Lizzie, mais il ne lui a pas parlé.
Darcy wanted-pfv talk to Lizzie, but he didn’t talk to her.

One glaring syntactic difference between French and Italian *want* is that the latter is a ‘Restructuring Predicate’ (i.e., its complement shows some transparency effects, which allows, for instance, clitic climbing). I will try to connect *volere*’s ability to yield actuality entailments to this more general ‘transparency’ property. I will show that the mechanism underlying actuality entailments with root modals is also responsible for the effect in (21). To do so, I will treat *volere* as an attitude-modal hybrid: like an attitude verb, and unlike real modals, its accessibility relation will be fixed (in terms of desires). Unlike attitude verbs, however, and like a root modal, I will take *volere* to be a functional element: it is not a verb, i.e., it is not a predicate of events. Thus, Aspect will be able to move from its base-generated position in the complement to a position above *volere* and force an actual event.

CHAPTER 1: MODAL AUXILIARIES: ASPECT AND ACTUALITY ENTAILMENTS

0. INTRODUCTION

This chapter focuses on French and Italian modal auxiliaries, and how aspect affects their various interpretations (epistemic, deontic, ability, goal-oriented, etc...). The main modals we will consider will be the standard French possibility modal *pouvoir* (and its Italian equivalent *potere*) and necessity modal *devoir* (and its Italian equivalent *dovere*). Our starting point is Bhatt's discovery (1999) that the modal *pouvoir/potere* on its ability reading interacts with aspect in a particular way⁷. Namely, with perfective morphology, *pouvoir/potere* seems to 'lose' its modal dimension by forcing the proposition expressed by the complement to hold in the *actual world*:

- (22) a. Jane a pu soulever cette table, #mais elle ne l'a pas soulevée.
b. Jane ha potuto sollevare questo tavolo, #ma non lo ha fatto.
Jane could-pfv lift this table, #but she didn't lift it
- (23) a. Jane pouvait soulever cette table, mais elle ne l'a pas soulevée.
b. Jane poteva sollevare questo tavolo, ma non lo ha fatto
Jane could-impf lift this table, but she didn't lift it

In the above examples (22) and (23) differ on the surface as follows: in (22) the modal shows *passé composé* morphology, which, morphologically decomposes into the auxiliary *have* and the participle form of the modal, and semantically, amounts to a combination of past tense and *perfective* aspect. In (23) it shows *imparfait* morphology, a morpheme placed directly on the modal, which, semantically, amounts to a combination of past tense and *imperfective* aspect. Truth-conditionally, the two differ in that (22) can only be true if Jane lifted the table *in the actual world* and not merely in *some* accessible world. This is why the continuation denying that she actually lifted it comes out as a contradiction. *Pouvoir/potere* has here an 'implicative' reading (that is, it behaves like an implicative predicate, such as *manage*). Or, in Bhatt's terminology, (22) yields an 'actuality entailment', i.e., an inference that the complement was realized, which cannot be cancelled. With imperfective aspect in (23), however, no such requirement holds: the complement is simply a possibility, which doesn't need to have been

⁷ Bhatt's data was primarily in Hindi and Greek but the facts are the same in French and Italian.

actualized. As we will see in chapter 2, the data with imperfective is slightly more complicated. We will see that, in some cases, a counterfactual meaning arises, where the complement is implied *not* to hold in the actual world. In other cases, imperfective yields a mere ability reading, which doesn't need to have been instantiated, nor *not* instantiated.

The first puzzle that needs to be explained is how this effect is at all possible. Indeed, at first blush, it looks as if perfective aspect removes the very characteristic of 'displacement' that defines modals: their ability to go beyond the realm of the 'actual' and into that of possibilities. How could a mere aspectual marker remove this essential property, if indeed, this is the proper characterization of the problem in (22) and (23)? As we saw in the introduction, it is important to note that this is not just a pragmatic effect: the inference is absolutely not cancelable, unlike the actuality implication that arises with closely related (meaning-wise) *have the possibility*:

- (24) Caroline a eu la possibilité de parler à Jane, mais elle ne lui a pas parlé.
Caroline had-pfv the possibility to talk to Jane, but she didn't talk to her.

There are (at least) three theoretical moves one can make: the first is to deny that we are dealing with a modal. This is the option Bhatt ends up arguing for: despite appearances, the ability modal is not a modal; it is an implicative predicate, which asserts the truth of its complement. The modal reading that emerges with imperfective morphology is not due to the semantics of the ability modal *per se*, but rather results from combining it with a modal element (a Generic Operator), itself associated with imperfective morphology. As we will see, the problem with such a move is that it treats the ability modal as a completely separate construction from other modals, despite the fact that cross-linguistically the same lexical item (e.g., *pouvoir*) is used to express abilities as to express, e.g., permission or epistemic possibility. The second option is to maintain that the ability modal *is* a modal, and that something in the semantics of perfective removes its modal dimension. As we saw in the introduction, the problem with this option is that in other (modal) environments, and even with other interpretations of the same modal auxiliaries, perfective doesn't necessarily yield actuality entailments; thus we don't want to make the semantics of the perfective too strong. The last option is to maintain that the ability modal is a modal and remains a modal even with perfective morphology. The 'actuality entailment' would be an additional side effect of the combination of the two. This last option, if attainable, would be the most desirable, given that it would allow us to maintain a unified

semantics both for modals and for perfective aspect. Moreover, as we will see in section 1.4., we have evidence that the modality doesn't completely disappear with perfective aspect. For these reasons, this is the option that I will pursue.

The second puzzle that emerges from the interaction of aspect and modal auxiliaries is that some, but not all, interpretations of these modals yield the actuality entailment effect in (15)/(23). For instance, *pouvoir* and *devoir* with an epistemic sense are not sensitive to aspect with respect to actuality entailment. Consider the following examples:

- (25) a. (Selon la voyante,) Bingley a pu aimer Jane.
(According to the fortune teller) Bingley could-pfv love Jane
b. (Selon la voyante,) Bingley pouvait aimer Jane.
(According to the fortune teller) Bingley could-impf love Jane
- (26) a. (Selon la voyante,) Bingley a dû aimer Jane.
(According to the fortune teller) Bingley must-pfv love Jane
b. (Selon la voyante,) Bingley devait aimer Jane.
(According to the fortune teller) Bingley must-impf love Jane

We will turn shortly to the meaning differences that arise from the two contrasting aspectual morphemes. However, one important fact to note is that, contrary to the ability reading, neither (18) nor (25) entails that Bingley loved Jane in the actual world, even with perfective aspect⁸.

Note that, unlike French, Italian doesn't allow epistemic interpretations when tense/aspect appears on the modals themselves. Hence, the equivalent of (25) and (26) in Italian requires aspect to be morphologically represented below the modal, as illustrated below. This option is also available in French (in (27)b and (28)b):

- (27) a. Bingley può aver parlato a Jane.
b. Bingley peut avoir parlé à Jane.
'Bingley might have talked to Jane'

⁸ The reason I put 'according to the fortune teller' is that, otherwise, the epistemic state being reported would be that of the speaker. This would blur the issue of whether we get an actuality entailment, given that a speaker should be as informative as possible, and speak truly. With a necessity epistemic modal, the actual world is among the worlds quantified over: thus, the speaker should believe that the complement holds in the actual world, hence a continuation denying it would be contradictory. Another way to show the difference between abilities and epistemics without having to report someone else's epistemic state is to have a continuation which grants the possibility that the complement didn't happen. With a root (ability) interpretation (i) is contradictory, but with an epistemic one, it isn't:

- (i) Bingley a pu parler à Jane, mais il (aussi) possible qu'il ne lui ait pas parlé.
Bingley can-pst-pfv talk to Jane, but is it (also) possible that he didn't talk to her.

- (28) a. Bingley deve aver parlato a Jane.
b. Bingley doit avoir parlé à Jane.
‘Bingley must have talked to Jane.’

We thus see that not all interpretations of modal auxiliaries yield an actuality entailment with perfective. How could we derive this difference of behavior? As we will see in chapter 3, many phenomena seem to set epistemic interpretations apart from ‘root’ ones (i.e., ability and its kin)⁹. It could be that the difference between the two runs very deep and that giving them a unified semantics is not only unattainable, but also misguided. This is in fact the direction that has been taken by quite a few researchers working on epistemic modality. However, there are two reasons which strongly favor an account that will give modal auxiliaries a core semantics: (i) the cross-linguistic trend to use the same lexical items to express abilities, as well as deontic and epistemic possibilities; (ii) despite undeniable differences in behavior, all modals do perform the same function: they express possibilities and necessities, which, in a possible worlds semantics framework amounts to existential and universal quantification over possible worlds. Given that these auxiliaries do in fact behave like modals more often than not, we should try to give them a core semantics, and derive the actuality entailment by adding or removing part of their meaning. As we will shortly see, we have truth conditionally detectable differences that indicate that the modality doesn’t completely disappear. Therefore, I will try to maintain a more standard semantics of modal auxiliaries in the spirit of Kratzer (1981, 1991), and derive the actuality entailment from a particular interaction with aspect.

This chapter will be organized as follows. In section 1, we will go over the different interpretations of the modal auxiliaries and see which are sensitive to aspect w.r.t. actuality entailments, and which aren’t. We will see that those that do are the root interpretations, and those that do not are the epistemics and true deontics. I will hypothesize that the reason why the latter are immune to the actuality entailment effect is due to the fact that they are interpreted above aspect. We will return to why this should be so in chapter 3. In section 2, I will show how to derive actuality entailments with perfective on root modals. I leave the question of how to avoid actuality entailments with imperfective morphology for chapter 2.

⁹ I am using the term ‘root’ loosely here. Traditionally, root modality includes deontics and dynamic modals, where dynamic modals consist of ability modals and dispositional *will*, as in ‘*Dogs will eat anything*’ (cf. Palmer 1986). As we will see, ‘deontics’ split into two classes: *ought-to-do* and *ought-to-be*, where the former pattern with abilities, and the latter with epistemics. In this thesis, I will use the term ‘root’ to refer to *ought-to-do* deontics and dynamics, and the term (*true*) *deontics* for *ought to be* deontics.

1. MODAL AUXILIARIES AND THEIR DIFFERENT INTERPRETATIONS: THE PATTERNS

1.1. A UNIFIED ACCOUNT OF MODAL AUXILIARIES (KRATZER 1981, 1991)

Before we delve into differences between the various interpretations of the modals, a brief summary of what modal auxiliaries are is in order. Syntactically, in French and Italian, modals take infinitival complements. They fully decline and, in that sense, they behave like regular verbs. As far as the aspectual class they belong to, modals are traditionally taken to be stative predicates (cf. Stowell 2004, a.o.): e.g., in English, they are licensed by present tense and do not allow progressive morphology. Thus, they behave more like statives (b) than eventives (c):

- (29) a. Jane can lift this table.
b. Jane knows Latin.
c. ??Jane goes to the bank. [unless habitual]
- (30) a. *Jane is canning lift this table.
b. ??Jane is knowing Latin.
c. Jane is going to the bank.

However, this kind of evidence is not black and white. As we see in (29)c), the accomplishment *go to the bank* allows present tense with a habitual interpretation; arguably then, the sentence in ((29)a) could involve an habitual ability. Upon closer examination at the aspectual behavior of modals, we see that it seems to depend both on the aspectual class of their complement, and on the interpretation of the modal. To illustrate, the sentence in ((31)a) feels very telic/eventive, while that in ((31)b) could not be more stative:

- (31) a. Jane a dû aller à la banque.
Jane must-pfv go to the bank
'(Yesterday) Jane had to go to the bank' [she did]
- b. Jane devait être heureuse.
Jane must-impf be happy.
'Jane had to be happy'

The position I will end up arguing for is that modals do not belong to any aspectual class, as they do not have their own event or state argument. As we will see, their interpretation will be relative to an eventuality, but their aspectual behavior will depend on their interaction with both the inner

(lexical) aspect and the outer (viewpoint) aspect (i.e., perfective or imperfective) of their complement.

Semantically, modals are taken to be quantifiers over *possible worlds* (cf. Kripke 1962, Lewis 1973, Kratzer 1981, 1991, a.o.). *Possible worlds* are possible states of affairs, possible ways the world could be. There are many ways the world could be and thus there is a multitude of possible worlds. There are worlds in which our friend Jane has three siblings. Among those worlds, there are worlds where she has two sisters, and one brother; there are other worlds in which she has three brothers. If I utter the sentence '*Jane may have a brother*', I am saying that there is a possibility that Jane has a brother. Or, in possible worlds talk, there is a possible world, among those that are compatible with what I know, in which Jane has a brother. What a possibility modal (e.g., *may*) does is to existentially quantify over worlds, the way *some* existentially quantifies over individuals. And just like there are existential (*some*) and universal (*every*) quantifiers over individuals, there are existential (*may, can, pouvoir...*) and universal (*must, devoir...*) quantifiers over possible worlds. If I had said '*Jane must have a brother*', I would have claimed that in *all* worlds compatible with what I know, Jane has a brother.

Notice that I snuck in a restriction. I did not say that there is a possible world among all possible worlds in which Jane has a brother. Rather, I restricted the domain of quantification to those worlds which are compatible with what I know. This is an *epistemic* accessibility relation (i.e., having to do with knowledge/evidence). This restriction plays an analogous role to the NP which restricts the domain of quantification of *some*, as in '*some man smokes*': there is an individual *x*, among the set of men, such that *x* smokes. Similarly, there is a world, among those that are compatible with what I know, in which Jane has a brother.

We just saw an instance of an *epistemic* accessibility relation. Our modal *may* can also be used with a deontic sense (having to do with laws or regulations), as in '*Jane may not watch TV*'. In that case, the accessibility relation would be *deontic* and thus restrict the domain to those worlds in which the rules established by Jane's parents are obeyed. In none of these worlds does Jane watch TV. Thus the same modals can have many flavors, depending on the type of accessibility relation that restricts them. The way we're able to identify which flavor a speaker has in mind seems to depend on the context in which these modal statements are made. For instance, if we're talking about what Jane is allowed to do, we'll naturally interpret a modal as being deontic. Kratzer (1981) proposes to derive the contextual nature of these accessibility

relations via *conversational backgrounds*. In her system, each modal auxiliary has a single lexical entry, which provides its quantificational force (existential or universal). These quantifiers are restricted by a conversational background, a *modal base*, which is contextually determined, and which can be brought about by phrases such as *in view of what the law says*. Let's start with an example:

(32) In view of what the law says, Jane must not steal.

The sentence in (32) does not mean that Jane does not steal in reality; she may be a convicted felon, and (32) would still be judged true. Instead, the modal allows us to talk about ideal situations: in our case, ideal w.r.t. the law: we want our modal to quantify over worlds in which the law is obeyed. The background here is what the law says. Thus, we could have a modal base $f_{\text{deontic}}(w)$, which is a set of propositions, such that each of these propositions expresses the content of a law in the base world w : e.g., there are no thief in w . In all of the worlds where the law is obeyed, Jane does not steal.

So far, so good. However, such a modal base is not sufficient, especially for deontic cases. Problems arise when the law is broken. Imagine that Jane actually steals. Then, according to the law:

(33) Jane must go to jail.

The problem is that our body of laws and regulations already excluded worlds in which there are thieves. Thus in all worlds in which the law is obeyed, Jane does not go to jail, because in all of these worlds, there is no crime. To get out of this conundrum, Kratzer proposes a second conversational background, the *ordering source*, which orders the worlds of the modal base according to an ideal, set by a body of law. It is now the ordering source which gives the modal its deontic flavor. The modal base, on the other hand, will now be 'circumstantial': it will be made up of the set of relevant facts of the base world w . It will notably contain the fact that Jane stole. The ordering source will be a set of propositions L , which describe a body of laws (e.g., there are no thieves, there is no murder, thieves go to jail, murderers go to jail...). This set of propositions L will impose the following ordering:

(34) Ordering \leq_L :

For all worlds $w, z \in W$: $w \leq_L z$ iff $\{p: p \in L \text{ and } z \in L\} \subseteq \{p: p \in L \text{ and } w \in L\}$

The ordering states that a world w will be more ideal than a world z , if more of the propositions in set L hold in w than in z . Thus, the best worlds according to this ordering source will be those in which no law is broken. A slightly less ideal world will have one law broken (e.g., Jane stole), but the others obeyed (Jane goes to jail), etc. Given that the circumstantial modal base returns a set of worlds in which Jane stole, the best worlds in this set will be those in which there is a thief, Jane, but where she goes to jail (i.e., one of the propositions in L doesn't hold, but the others do).

To sum up, the modal *must* is a universal quantifier over possible worlds. With a deontic interpretation, it is first restricted by a *circumstantial* modal base $f(w)$, which returns a set of worlds in which certain facts in w hold (e.g., Jane stole a car). The set of worlds given by $f(w)$ are then ordered by an ordering source $g(w)$, according to an ideal provided by the law. Note that both $f(w)$ and $g(w)$ are contextually determined. This allows for a single entry for *must*:

(35) For any world w , conversational backgrounds f, g , and proposition q :

$[[\text{must}]](w)(f)(g)(q) = 1$ iff $\forall w' \in \max_{g(w)} (\cap f(w))$: $q(w') = 1$.

Where $\max_{g(w)}$ is the selection function that selects the set of $\leq_{g(w)}$ -best worlds.

For Kratzer, there are two kinds of modal bases. First is the *epistemic* one, which picks the set of worlds compatible with the speaker's knowledge (or that of a larger community) in w . The second is the *circumstantial* modal base. To get at the contrast between the two modal bases, consider the pair of examples below. English *might* and *can* help bring out this contrast, as they each have some selectional constraints which forces *might* and disallows *can* to select an epistemic modal base. With French and Italian *pouvoir/potere*, either modal bases are available:

(36) a. Hydrangeas might grow here.

b. Hydrangeas can grow here.

[Kratzer (1981)]

The sentence in (a) is evaluated against an epistemic modal base: To the best of my knowledge, it is possible that hydrangeas grow here. The sentence in (b) is evaluated against a circumstantial modal base, that is, one which picks out worlds in which certain facts of the world hold. Such facts will include the quality of the soil, the climate, etc. While the difference in meaning might seem subtle, they actually yield different truth conditions. If I know for a fact that there are no

hydrangeas in this part of the country, (a) will be false; however, the circumstances for hydrangeas to grow might still be ideal, and the sentence in (b) will then be true.

To sum up, Kratzer shows that the different meanings that arise with modals can vary along three dimensions: the **force** (existential or universal), which is lexically determined; the **modal base**, which is either circumstantial (the modal base involved in all root modals) or epistemic. Finally, there is the **ordering source**, which follows the template in (34), and where what changes from one ordering source to the next is the set of propositions that establishes the ordering: deontic (laws), bouletic (wishes), teleological (aims), stereotypical (normal course of events). Both the modal base and the ordering source are contextually given, and not all combinations of modal bases and ordering sources are possible.

The modal flavors we will be primarily concerned with will be epistemics, deontics and a series of circumstantial ones. These circumstantial ones will include abilities, as in '*Jane can lift this table*'; pure circumstantials, as in '*hydrangeas can grow here*'; and goal-oriented ones, as in '*Jane can take the train to go to Paris*'. Goal-oriented modality involves a circumstantial modal base: the circumstances will include things such as the train schedule, the fact that there are rail tracks from here to Paris, etc. The set of accessible worlds is further restricted to those in which Jane reaches her goal of going to Paris: in some world compatible with certain facts of the actual world and where Jane goes to Paris, Jane takes the train in it.

1.2. INTERPRETATIONS OF MODAL AUXILIARIES AND SENSITIVITY TO ASPECT

In this section we will first go over the different possible interpretations of modal auxiliaries and see which yield actuality entailments, and which do not. The first interpretation to show sensitivity to aspect is the ability modal in (15), repeated below:

- (37) a. Jane a pu soulever cette table, #mais elle ne l'a pas soulevée.
Jane could-pfv lift this table, #but she didn't lift it
- b. Jane pouvait soulever cette table, mais elle ne l'a pas soulevée.
Jane could-impf lift this table, but she didn't lift it

Another interpretation to yield this effect is a teleological (or goal-oriented) interpretation, which has to do with the possibilities and necessities circumstantially available to the subject, given certain goals of the subject. The following examples illustrate:

- (38) a. Jane a pu prendre le train pour aller à Londres, #mais elle a pris l'avion.
Jane could-pfv take the train to go to London, #but she took the plane
- b. Jane pouvait prendre le train pour aller à Londres, mais elle a pris l'avion.
Jane could-impf take the train to go to London, but she took the plane
- (39) a. Jane a dû prendre le train pour aller à Londres, #mais elle a pris l'avion.
Jane must-pfv take the train to go to London, #but she took the plane
- b. Jane devait prendre le train pour aller à Londres, mais elle a pris l'avion.
Jane must-impf take the train to go to London, but she took the plane

The above examples relate the possibility and the necessity of taking the train, given Jane's goal to go to London. With perfective morphology, both the possibility ((38)a) and the necessity (39)a) modals require that Jane took the train in the actual world, whereas with imperfective, neither of them do.

We saw that (French) epistemics, on the other hand, do not yield actuality entailments with perfective morphology. In examples (18) and (25) repeated below, aspect did not affect the non-implicative behavior of modals, under an epistemic interpretation:

- (40) a. (Selon la voyante,) Bingley a pu aimer Jane.
(According to the fortune teller) Bingley could-pfv love Jane
- b. (Selon la voyante,) Bingley pouvait aimer Jane.
(According to the fortune teller) Bingley could-impf love Jane
- (41) a. (Selon la voyante,) Bingley a dû aimer Jane.
(According to the fortune teller) Bingley must-pfv love Jane
- b. (Selon la voyante,) Bingley devait aimer Jane.
(According to the fortune teller) Bingley must-impf love Jane

However, there still seems to be a meaning difference that arises from the aspect morphology on the modal. Let's look at (41) more closely. In (a), according to the fortune teller, it must be the case (at the time of utterance) that, at some past time, Bingley loved Jane (with an implication that he doesn't love her anymore). In (b), according to the fortune teller, it must be the case (at utterance time) that at some past time Bingley *was in love* with Jane (with no implication about whether he still does or not). The fortune teller could have expressed herself as follows:

- (42) a. Je pense que (l'été dernier) Bingley a aimé Jane.
I think that (last summer) Bingley loved-pfv Jane
- b. Je pense que (l'été dernier) Bingley aimait Jane.
I think that (last summer) Bingley loved-impf Jane

We see that the epistemic necessity holds **now**, given the fortune teller's evidence at the time of utterance, about some past time. That past reference time (last summer) is included within the loving state with imperfective (b), while in (a) the reference time (last summer) contains the loving state – hence the implication that the state doesn't hold anymore can be derived through pragmatic reasoning (cf. discussion on stative predicates and perfective in the introduction). One can transparently see in (42) that the aspectual morphology is interpreted on the complement. Thus in (40) as well, and despite the fact that the aspect morphology (in French) appears **on** the modal itself, it is interpreted below it, namely on the complement clause. This is further brought out in the following examples. The adverb *déjà* (already) with perfective means something like 'once before'. With imperfective, it means 'already at the time'.

- (43) a. Bingley a déjà aimé Jane.
Bingley has already loved Jane
'Bingley has loved Jane once before.'
- b. Bingley aimait déjà Jane.
Bingley loved-impf already Jane
'Bingley was already in love with Jane.'

This is the interpretation we get when we add an epistemic modal:

- (44) a. Bingley a déjà dû aimer Jane.
Bingley has already must loved Jane
'Bingley must already have loved Mary (once before).'
- b. Bingley devait déjà aimer Jane.
Bingley loved-impf already Jane
'Bingley must already have been in love with Mary (at the time).'

What about deontic interpretations? Do they pattern with epistemic or with ability/teleological interpretations? At first blush, it seems that they also yield an actuality entailment:

- (45) a. Lydia a pu aller chez sa tante (selon les ordres de son père).
 Lydia could-pfv go to her aunt
 → Lydia went to her aunt
- b. Lydia a dû faire la vaisselle (selon les ordres de son père).
 Lydia must-pfv do the dishes
 → Lydia did the dishes

However, some deontics are easily confused with teleological modals (cf. von Stechow & Iatridou, 2005). (45)b) could be interpreted as ‘Lydia did the dishes *in order to obey her father*’ or again ‘*in order not to get punished by her father*’. The actuality entailment makes it particularly difficult to identify the modals in (45) as having a deontic interpretation. What usually helps us identify a modal as being deontic (i.e., having to do with laws) is precisely that these laws are constantly broken in actuality (e.g., you’re supposed to not go over the speed limit, but you still do). Thus the actuality entailment further blurs the exact nature of the modal interpretation.

An important contrast to keep in mind, when discussing deontics, is Feldman’s (1986) distinction among deontic modals between *ought-to-be* and *ought-to-do* deontics. Observe the following contrast:

- (46) a. Murderers ought to go to jail.
 b. Wickham ought to apologize.

The most natural interpretation of (46)a) is that *it ought to be that murderers go to jail*, rather than ‘*murderers have an obligation to go to jail*’. While (46)b) can also have that meaning, the more straightforward reading is one where the obligation is on the subject himself: *what Wickham ought to do is apologize*.¹⁰ As the following example illustrates, the same sentence can have either one of these interpretations (cf. Bhatt 1998):

- (47) Kitty has to brush her teeth.

With the *ought-to-do* interpretation, the sentence in (47) expresses an action that the subject, Kitty, ought to do, if she doesn’t want to get cavities, or be yelled at by her mother. The sentence also has an *ought-to-be* interpretation, as in the case where it is uttered by Kitty’s mother to the

¹⁰ Note that I am using the *ought-to-do/ought-to-be* labels to refer to the distinction between the class of deontics that puts an obligation on the subject vs. that which puts an obligation on the addressee. My claims are not about the English modal *ought* itself, whose own particularities would lead us too far astray. For a proposal, see von Stechow and Iatridou, *in progress*.

babysitter: the mother is placing an obligation on the babysitter directly, and not on Kitty: it ought to be that Kitty brushes her teeth.

I believe that there is a fundamental distinction between these two types of deontics. *Ought-to-do* deontics are the kind captured in Kratzer's system via a circumstantial modal base (which picks out facts of the base world) and a *deontic* ordering source. *ought to be* deontics, on the other hand, seem to double a modal statement with a performative act, namely, that of putting an obligation on the addressee (cf. Ninan 2005): the babysitter in (47), and perhaps a larger community in (46)a). There is no performative dimension in cases of *ought-to-do* deontics, which simply describe an obligation on the subject. Thus arguably *ought-to-do* deontics are closer in meaning to goal-oriented modals than to *ought-to-be* deontics (both share a circumstantial modal base, and are, in a sense to make precise in chapter 3, subject-oriented). In fact, many instances of *ought-to-do* deontics can be reduced to goal-oriented modality, where the goal is unpronounced and often deals with avoiding some kind of punishment. The following sentence is not so much a statement about what the laws of this world look like, but rather a statement of what I need to do, given a certain body of laws and regulations in effect in the actual world, *in order for me not to get a ticket*:

(48) I have to take out the trash on Wednesdays.

Why should such a distinction matter? We will see more syntactic and semantic evidence for such a split in chapter 3. For now, I would like to show that this distinction is relevant for the actuality entailment pattern. When we turn to modalized constructions other than the standard modal auxiliaries, we see that 'real' deontic (i.e., not reducible to goal-oriented) interpretations do not yield actuality entailments. In French (and Greek), '*permit*' is ambiguous between a *grant permission* reading ((49)a), which doesn't yield an actuality entailment; and an *enable* reading (49)b), which does (S. Iatridou, p.c.):

- (49) a. Le doyen m'a permis d'utiliser la bibliothèque.
The dean permitted-pfv me to use the library
- / → I used the library
- b. Cette carte m'a permis d'utiliser la bibliothèque.
This card permitted-pfv me to use the library
→ I used the library

(49) suggests that a ‘real’ deontic (real in the sense of someone granting permission or putting an obligation on someone else) doesn’t yield an actuality entailment. Furthermore, consider the case of the modal *être censé/être supposé* (*be supposed to*), which can only have epistemic/deontic interpretations, but not goal-oriented ones (K. von Stechow, p.c.). As the following example shows, it doesn’t yield an actuality entailment with perfective:

- (50) ??Kitty a été censée/supposée faire ses devoirs, ^{ok}mais elle ne les a pas fait.
Kitty was-pfv supposed to do her homework, but she didn’t do it

Perfective morphology on this modal is almost unacceptable, but to the extent that it is grammatical, it certainly doesn’t yield an actuality entailment: the continuation is not contradictory, hence (50) doesn’t entail the actualization of its complement.

When we turn back to modal auxiliaries, we see that a similar effect arises. *Devoir* can have a true (performative) deontic reading (i.e., addressee-oriented, or *ought-to-be*) or a goal-oriented-type reading (subject-oriented or *ought-to-do*). To bring out the true deontic reading, consider a version of the babysitter example, where Kitty’s mom comes back and sees that Kitty’s homework has been left untouched. She addresses the babysitter (*‘Congratulations!’* helps bring out the performative reading: the speaker performs a congratulatory act to her addressee, here, sarcastically):

- (51) ??Kitty a dû faire ses devoirs, mais elle ne les a pas fait. Bravo!
Kitty must-pfv do her homework, but she didn’t do it. Congratulations!

This is just as odd as (50) is. And the oddity does not come from the fact that the continuation seems contradictory. Even if the mother comes back and sees that the babysitter did her job of ensuring that Kitty did her homework, she cannot say:

- (52) ??Kitty a dû faire ses devoirs, et elle les a fait. Bravo!
Kitty must-pfv do her homework, and she did it. Congratulations!

Note that with imperfective aspect, this is fine again (as is the *supposed to* example):

- (53) a. Kitty devait faire ses devoirs, et elle les a fait/mais elle ne les a pas fait (bravo!).
Kitty must-imp do his homework, and she did/but she didn’t (congratulations!).
b. Kitty était censée faire ses devoirs, et elle les a fait/mais elle ne les a pas fait (bravo!).
K. was-impf supposed to do her homework, and she did/but didn’t (congratulations!)

There thus seems to be an incompatibility between perfective aspect and true (performative) deontics, which involve putting an obligation on someone else. This can be explained by appealing to the fact that putting an obligation on an addressee *after the fact* is simply pointless. As we will see further in chapter 3, it is impossible to request of someone that they bring about a *past* state of affairs (cf. Ninan 2005). If the mother wanted to scold the babysitter for failing to fill her obligations, she should have used a counterfactual, either by using *conditionnel* morphology (a morpheme used to express counterfactuality), or imperfective (which can also express counterfactuality, as we will see in chapter 2, as in (53)). Deontics split into two classes: addressee-oriented, and subject-oriented deontics, which pattern with goal-oriented interpretations.

Thus, the modal interpretations that yield actuality entailments are the circumstantial ones: ability, goal-oriented, ought-to-do deontics, and the pure circumstantials. Those that do not are the epistemics and true deontics. We further saw that the ones that do not are interpreted *above* aspect. In the case of epistemics, the aspect that appears on the modals themselves is interpreted below them. For true (ought-to-be) deontics, we saw that perfective was ungrammatical. The reason, I believe, is that the tense and aspect are interpreted under the modal, but the meaning that results is incoherent, as it puts a *present* obligation to bring about a *past* state of affairs. Imperfective aspect was fine, but it yielded a counterfactual meaning. I will thus hypothesize that the reason why epistemics and true deontics are immune to actuality entailments is because they are interpreted above aspect. Conversely, circumstantials are interpreted below aspect. In section 2, I will show how to derive actuality entailments, once we assume that aspect is above the modal. I will return to the question of why epistemics and true deontics are interpreted above aspect in chapter 3. We will see that this fact is in line with other syntactic and semantic phenomena which suggest that the two classes differ in height of interpretation: not only are they interpreted above aspect, they also tend to be interpreted above many scope-bearing elements (negation, tense, quantifiers), whereas circumstantials tend to be interpreted below these elements.

1.3. HEIGHT OF INTERPRETATION: SYNTAX, MORPHOLOGY AND SCOPE

The working hypothesis in this chapter is that we have a difference in height of interpretation for the two classes of modal interpretations, one above aspect, and one below it. The question is

whether we are dealing with a difference in scope or not. Does the final ordering of modals and aspect involve QR (Quantifier Raising)? And if so, is it QR of the modal auxiliaries or that of aspect? Assuming covert movement of the modals might have undesirable consequences. For instance, we should expect the possibility for inverse scope with two modals in a row, which we do not get (von Stechow and Iatridou 2003; von Stechow and Heim 2002). The sentence below cannot mean that Jane had permission to *have to* watch TV. Note that it isn't a quirk of the periphrastic 'be allowed' to. In the French version of the example, stacking modals yields a fixed order that reflects the surface order:

- (54) a. Jane should be allowed to watch TV.
 b. Jane doit pouvoir regarder la télé.
 Jane must can watch TV.

Furthermore, if the movement of the modal were covert, we might not expect a difference between French and Italian. Recall that in French, aspectual morphology on the modal either yields a circumstantial or an epistemic interpretation. In Italian, however, no epistemic interpretation is possible. Instead, aspect needs to be overtly realized on the complement:

- (55) a. Bingley a pu parler à Jane. [epistemic]
 b. *Bingley ha potuto parlare a Jane. [*epistemic]
 Bingley can-pst-pfv talked to Jane.
 c. Bingley peut avoir parler à Jane.
 d. Bingley può aver parlato a Jane.
 Bingley can-pres have talked to Jane.
 e. MOD -T -Asp -VP

I thus propose that the different heights of interpretation result from a different order in overt syntax¹¹. In French, the two possible orders 'Tense-Aspect-Modal' and 'Modal-Tense-Aspect' have the option of having the same morphological spell-out. Italian, on the other hand, doesn't allow 'Modal-Tense-Aspect' to be spelled out as one morphologically complex unit. This difference should fall out from morphological constraints. A precise account of what these constraints are is beyond the scope of this work. It might be due, for instance, to some morphological blocking due to the language-specific assignment of which head (tense or modal

¹¹ Thanks to Alec Marantz for helpful discussion on the topic.

or AGR) carries case and agreement features (cf. Giorgi and Pianesi 1997 for a proposal on the morphological constraints on tense). Differences in morphological spell out between French and Italian are otherwise attested. Consider the following examples from Kayne (1991). In the infinitives below, Italian shows clitic right-adjunction, while French has clitic left-adjunction:

- (56) a. *Parler lui / ^{ok}Lui parler serait une erreur.
 b. ^{ok}Parlagli/ *gli parlare sarebbe un errore.
 Talk-him/him talk be-cond a mistake
'Talking to him would be a mistake'.

Kayne argues that the clitic right adjunction in Italian results from an extra V-movement. In Italian, it would be necessary for V to move past adverbs between T and I, but not in French, a property he links to the null subject parameter. Whatever mechanism is responsible for the difference in (56)a) (e.g., extra verb movement in Italian; 'affix'-lowering allowed in French; case/agreement features) could be connected to the contrast with epistemic modals. At the very least, it indicates that, while the two languages are closely related, their morphological component seems to be subject to different constraints. I leave precise morpho-syntactic details for future research. Suffice it to say, for our purposes, that the differences between French and Italian epistemic interpretations should result from morphological constraints (which are independently attested), rather than from differences in what can *covertly* move.

2. PROPOSAL

In this section, I will show how to derive an actuality entailment. To make the following discussion easier to follow, I will give the punch line right away. The actuality entailment results from the modal's relative height with respect to aspect: when aspect is above the modal, we get an actuality entailment (provided there is no extra layer of modality above it); when aspect is below it, we don't get an actuality entailment. This is so because, as we will see, aspect comes with its own world argument, which needs to be bound locally. This world argument has to be bound by a modal immediately above it, but cannot be bound by that modal, if the modal is below it. In that case it has to be bound by whatever mechanism is responsible for defaulting to the actual world in matrix contexts (e.g., explicit binders in the syntax, à la Percus 2000). When the world argument of aspect is the actual world, this will yield an actual event (provided, again,

that there is no extra layer of modality, as I will argue in chapter 2 is the case for the imperfective).

2.1. ASSUMPTIONS: TENSE AND ASPECT

Before going into the specifics of how this is done, I will first make explicit my assumptions for the semantics of tense and aspect.

2.1.1. *Tense and world pronouns*

There are many ways that Tense could be encoded in the grammar, and both the linguistic and the philosophical literature is very rich on the topic. In classic accounts of Tense in the Prior and Montague tradition, times are manipulated in the meta-language. Each lexical item is evaluated w.r.t. to a time (on top of a world) parameter, which can be manipulated by tense operators (PRESENT or PAST). Thus, PAST has the following semantics:

$$(57) \quad [[\text{PAST } \phi]]^{g,t,w} = 1 \text{ iff there is a time } t' \text{ s.t. } t' < t \text{ \& } \phi(t') = 1$$

More recently, however, there has been a trend in the literature to move away from treating Tense and Mood as sentential operators, but rather to have explicit quantification in the syntax (cf. e.g., Kusumoto 2002 for more details). Partee (1973) first pointed out that a more adequate theory of tense should treat tenses as pronouns, or variables, on a par with individuals. This move rests on arguments that tenses have all of the uses that individual pronouns do, and thus, should receive a similar analysis. For instance, the sentence below shows that we can refer *deictically* to a time interval (the same way ‘he’ or ‘she’ can refer deictically to someone), and that, moreover, an operator-type analysis of tense is inadequate for such cases:

$$(58) \quad \text{I didn't turn off the stove.} \qquad \qquad \qquad [\text{Partee (1973)}]$$

(58) doesn't mean ‘*at no time prior to the utterance did I turn off the stove*’, which is obviously false, nor the trivially true ‘*there is some point in the past where I did not turn off the stove*’. Instead, the most straightforward reading of (58) is that there is a salient past interval (e.g., right before I left my house) where I didn't turn off the stove. Note that Stone (1997) argues that,

similarly, mood has some *deictic* uses as well. In the following example, we're referring to *those* worlds in which my friend turns the music up:

(59) [To a friend who's about to turn the music up] My neighbors would be very upset.

These sorts of examples seem to argue away from treating worlds and times as mere parameters, but rather to have them explicitly represented: like pronouns, they can have indexicals, anaphoric or bound variable uses (cf. Kratzer 1998, Schlenker 2002, a.o.). At the very least, there seem to be compelling reasons to move away from operator-like analyses of tense and mood, where a tense/modal operator will blindly give a value to any time or world variable in its scope, and to have a more unified account of quantification across domains¹².

Following Partee (1973), Kratzer (1998), a. o., I will assume a referential analysis of tense, where tenses are pronouns. They combine with predicates of times, the same way an individual pronoun combines with a predicate of individuals. In Kratzer's system, the two main tenses are indexical pronouns (present and past):

- (60) a. $[[\text{pres}]]^{g,c}$ only defined if c provides an interval $t \approx t_0$ (speech time).
If defined $[[\text{pres}]]^{g,c} = t$.
- b. $[[\text{past}]]^{g,c}$ only defined if c provides an interval $t < t_0$ (speech time).
If defined $[[\text{past}]]^{g,c} = t$.

Note that the overlap/anteriority relation w.r.t. the utterance time of the tenses is given by a presupposition. Anaphoric tenses (or zero tenses, in Kratzer's terminology) will arise in cases of embedding under attitude verbs. 'Zero tenses are lexically indexed variables that have no presuppositions and must be bound by a local antecedent' (e.g., a pres or a past):

- (61) a. $[[\emptyset_n]]^{g,c} = g(n)$

Similarly for worlds. Percus (2000) argues that there are explicit world pronouns (situation pronouns in his framework) in the syntax, and that these pronouns need to be bound. In matrix context, he assumes a topmost default world binder, which maps to the actual world. Other binders include those introduced by attitude verbs or adverbs of quantification. I will

¹² One exception: the Generic Operator, which unselectively binds any free variable in its scope (cf. Chapter 2).

follow Percus' two assumptions, namely that (i) there are explicit world variables represented in the syntax (rather than relying on a world parameter in the index), and (ii) the binding of these variables obey strict locality conditions: they need to be bound by a matrix binder or a closer binder when available.

2.1.2. Aspect

We will thus treat tenses and worlds as pronouns, on a par with individuals. What about aspect? What role does it play? What does it manipulate? In order to account for aspectual properties of natural language, one needs to assume, at the very least, a notion of time intervals which can overlap, be sequential, etc. A more elegant, and perhaps more intuitive way to encode these aspectual properties is to assume an extra entity in our ontology, namely *events*. We see that tenses refer to times: they are pronouns, which combine with predicates of times. Similarly, we will have events, which will combine with predicates of events. The role of aspect will be to take predicates of events and return predicates of times, which, in turn will combine with tenses.

2.1.2.1. Events

While finding a precise definition for what an event is has proven to be a rather difficult task (as we will see in section 2.3), events themselves are a very intuitive notion. The layman will easily conceive of *drinking a cup of coffee* or *reading a paper* or *getting a 3rd degree burn* as self-contained units, which can be repeated, or overlap, or enter into causal relations. And indeed, our conception of events mimics closely our conception of objects: we can see (an event of) Jane crossing the street, just like we can see a table in front of us; we can *drink a cup of coffee again*, just like we can drink *another* cup of coffee. A crucial argument for actually representing events in natural language was put forward by Davidson (1967), and involves entailment patterns between sentences, such as the ones below:

- (62) a. Brutus killed Caesar.
b. $\exists e[\text{kill}(e) \ \& \ \text{Agent}(e,C.) \ \& \ \text{Theme}(e,B.)]$
c. Brutus killed Caesar with a knife.
d. $\exists e[\text{kill}(e) \ \& \ \text{Agent}(e,C.) \ \& \ \text{Theme}(e,B.) \ \& \ \text{Instrument}(e, \text{knife})]$

If events were not represented, we would have no straight-forward way of deriving the asymmetric entailment from (c) to (a), as the two predicates *kill* and *kill with a knife*, would be independent from one another. Once we have events, however, we clearly see how (d) entails (b), but not vice versa.

Since Davidson's work, then, it has become rather standard to assume that predicates take an event or situation argument (roughly defined as a spatio-temporal slice). In other words, VPs are predicates of events:

- (63) a. $[[VP]] = \lambda e. P(e)$
 b. $[[rain]] = \lambda e. rain(e)$

Where does that leave individual arguments? For concreteness purposes, I will choose assumptions which in my eyes look the most promising, which I won't motivate, for reasons of space (I refer the interested reader to Kratzer 1996). For Davidson, a predicate like *kill* is a 3-place predicate: it takes an event, an agent, and a theme. Neo-Davidsonians have argued that each argument has to be introduced separately, the way it is represented in (62). I will assume, following Kratzer (1996), that there is an asymmetry between the internal and the external argument of a verb (cf. also Marantz 1984), such that the object and the event should be arguments of the verb itself, while the external argument should be introduced by a separate *voice* projection. What sits in *voice* is an Agent relation, for eventive predicates, or an Experiencer relation for stative predicates. The VP and the agent combine through an operation of *Event Identification*, and return a predicate of events:

- (64) a. $[[kill]] = \lambda x \lambda e. kill(x)(e)$
 b. $[[kill\ the\ dog]] = \lambda e. kill(the\ dog)(e)$
 c. $[[Agent]] = \lambda e \lambda x. Agent(x)(e)$
 d.

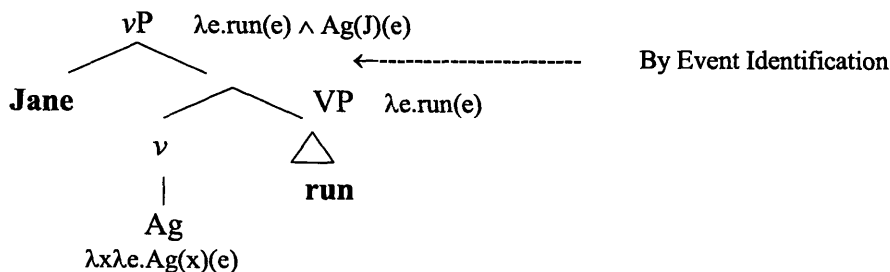

At the vP level, we then have a predicate of events, which needs to combine with an event. As we will see in the next section, this is where Aspect comes in: Aspect is a quantifier over events, which takes a predicate of events, and turns it into a predicate of times. The predicate of times can then combine with a tense.

2.1.2.2. Aspect

The primary function of Aspects is to quantify over event variables, and transform a predicate of events into a predicate of times. Differences between the various aspects have to do with the durational properties of these events. Intuitively, progressive/imperfective aspect (b) ‘stretches’ an event so that the duration of that event surrounds a reference time, while a perfective (a) ‘squeezes’ an event inside a reference time:

- (65) a. Yesterday afternoon, Jane read a book.
 b. Yesterday afternoon, Jane was reading a book.

In (a) the running time of Jane reading a book is contained within *yesterday afternoon*, whereas in (b) it surrounds *yesterday afternoon*. Thus, for (a) to be true, Jane must have finished her book yesterday afternoon, but no such requirement holds for (b).

More formally, it has been assumed that perfective and imperfective aspects both existential quantify over the event variable and locate the temporal trace of the event ($\tau(e)$, following Krifka, 1992) with respect to the evaluation time given by Tense. The difference between the two aspects is that perfective locates the time of the *event* within the reference time, while imperfective locates the *reference time* within the event time (cf. Klein 1994). As a starting point, I will use the following lexical entries (from Kratzer 1998):

- (66) a. [[PERFECTIVE]] = $\lambda P. \lambda t. \lambda w. \exists e[\tau(e) \subseteq t \ \& \ P(e)(w) = 1]$
 b. [[IMPERFECTIVE]] = $\lambda P. \lambda t. \lambda w. \exists e[t \subseteq \tau(e) \ \& \ P(e)(w) = 1]$

(67) illustrates the combination between the two aspects and the predicate of events *rain*. Recall that I assume an indexical role for Tense which orders the evaluation time with respect to the utterance time (Past needs a time that precedes the utterance time, Present, one that overlaps with it), through a presupposition (indicated within curly brackets):

- (67) a. Il a plu.
 It rained-pfv
 $\exists e[\tau(e) \subseteq t \{t < t^*\} \ \& \ \text{rain}(e, w^*)]$
- b. Il pleuvait.
 It rained-impf
 $\exists e[t \subseteq \tau(e) \{t < t^*\} \ \& \ \text{rain}(e, w^*)]$

It is assumed, traditionally, that the aspect projection is base-generated under tense, and binds event variables in its scope. Thus a verb would have a free event argument that would get bound by the aspect above it. However, I would like to explore an alternative to this view (suggested in lecture notes by von Stechow, 2001), namely that aspect is directly base generated as an argument of the verb. Being of the higher quantifier type, aspect will then move out of this position and leave a trace of type ε (for eventualities), which it will bind from its target position, the same way a quantifier over individuals in object position moves up and leaves a trace of type e . Aspect is thus a quantifier of type $\langle\langle \varepsilon, t \rangle, \langle i, t \rangle\rangle$: it first moves out of its base position and then moves right below Tense, in order to combine with a time argument (of type $\langle i \rangle$), to finally return a truth value (ignoring worlds for the moment):

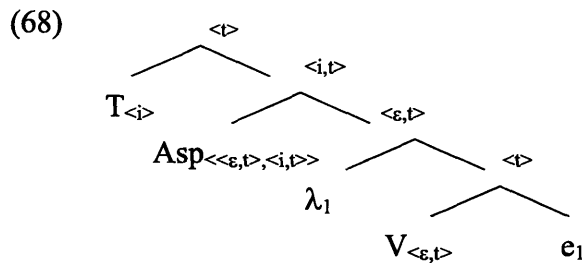

In simple cases, the two options will be equivalent, and the quantifier movement’s appeal might then be purely esthetic, as it maintains a parallel between quantification over events and quantification over individuals. However, if a modal intervene between Tense and Aspect, the quantifier movement approach allows aspect to move above the modal and bind the event argument (its trace) below the modal quite naturally¹³:

¹³ Note that we could take this proposal one step further by assuming that tenses are also quantifiers merged as argument of aspect, which in turn have to move for type reasons. One more step would have modals (quantifiers over worlds) merge as arguments of tense (cf. von Stechow 2001), and also move for type reasons. For reasons of space and time, I won’t pursue this option further, and leave it open for future research.

(69)

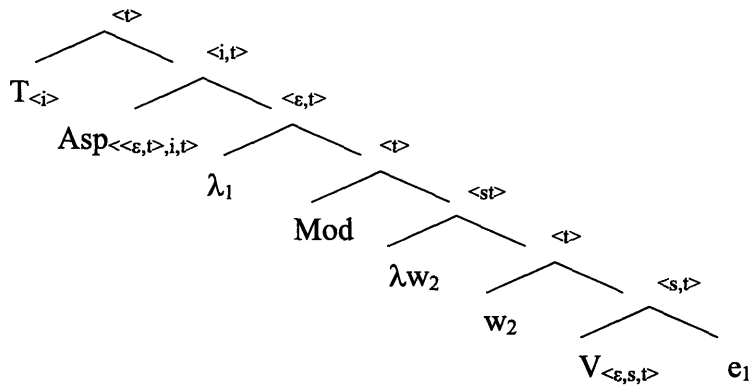

One additional assumption will then allow us to derive the actuality entailment quite naturally: Aspect takes a world argument in its restriction, as well as in its scope, again paralleling quantifiers over individuals. And, as in the case of quantifiers over individuals, the two world arguments may be bound by different binders. Consider the following example from Percus (2000):

(70) If every semanticist owned a villa in Tuscany, what a joy it would be.

The sentence in (70) is ambiguous between two readings: the ‘transparent’ reading asserts that all of the worlds in which every current/actual semanticist owns a villa in Tuscany are happy worlds (two different world indices). The ‘opaque’ reading states that all of the worlds where every semanticist in *those* worlds own a villa are happy worlds (same world indices). In other words, the world argument associated with the NP semanticist can either be the actual world, or the world being quantified over in the *would*-conditional. In order to capture this, Percus argues that there are explicit world variables, which need to be bound, either by a default binder in a matrix context that maps to the actual world, or by a binder provided by e.g., a modal. Percus further claims that these binding possibilities obey some binding principles, which differentiates between the world variable inside the restriction of a quantifier like *every* (in our example [semanticist in *w*]), and the world variable inside its scope (here [own a villa in *w*]). While the former can be bound by either by the matrix binder (yielding actual semanticists), or by the binder provided by *would* (yielding semanticists in the counterfactual worlds), the binding of the world variable inside the scope of the quantifier seems to obey some strict locality principle: it has to be bound by the closest binder. In the above example, this is the binder provided by *would*

(λ_1). This binding principle prevents unattested readings of (70) where we talk about semanticists in the counterfactual worlds (or in the actual world), owning villas in the **actual world**:

- (71) a. λ_0 [_{IP1} if [_{IP2} λ_1 [_{IP3} [every semanticist w_0] own-villa w_1] what a joy]
 b. λ_0 [_{IP1} if [_{IP2} λ_1 [_{IP3} [every semanticist w_1] own-villa w_1] what a joy]
 c. * λ_0 [_{IP1} if [_{IP2} λ_1 [_{IP3} [every semanticist w_0] own-villa w_0] what a joy]
 d. * λ_0 [_{IP1} if [_{IP2} λ_1 [_{IP3} [every semanticist w_1] own-villa w_0] what a joy]

Going back to Aspect, I would like to argue for a similar architecture. Aspects are quantifiers over events: they have a world pronoun in their restriction. I therefore propose to modify Kratzer's entries as follows. (Note that the world argument in the scope of Aspect will come from the predicate of events):

- (72) a. [[PERFECTIVE]] = $\lambda w. \lambda t. \lambda P_{\langle st \rangle}. \exists e[e \text{ is in } w \ \& \ \tau(e) \subseteq t \ \& \ P(e) = 1]$ ¹⁴
 b. [[IMPERFECTIVE]] = $\lambda w. \lambda t. \lambda P_{\langle st \rangle}. \exists e[e \text{ is in } w \ \& \ t \subseteq \tau(e) \ \& \ P(e) = 1]$

These lexical entries differ from Kratzer in two respects: (i) the order of arguments and (ii) where the world anchoring happens. Let's put all of the pieces together in a simple example to illustrate. Recall that I follow Percus (2000) in assuming overt world pronouns in the syntax:

- (73) a. Il a plu.
 It rained-pfv

¹⁴ In her analysis of counterfactuals, Arregui (2005) gives an interesting proposal for perfective aspect, which could perhaps be used in alternative to the present account of the perfective. For her, perfective is a deictic (default) aspect, which introduces a free event variable (as opposed to the perfect, which, in her account, is a quantifier over events). The denotation of this variable is an *actual* world event that fits the description given by the VP.

(i) $[[\emptyset_{\text{perfective}} - e]]^{\#} (P) = \lambda t \lambda w [P(g(e))(w) \ \& \ \tau(g(e)) \subset t]$

One potential issue for Arregui's perfective is that under attitudes, a perfective doesn't yield an actual event of any kind. Note that the presence of the time adverbial prevents us from saying that it is a Kratzerian (1998) perfect:

(ii) Jane pense que Bingley a pris le train à 3 heures.
 Jane thinks that Bingley took-pfv the train at 3:00pm

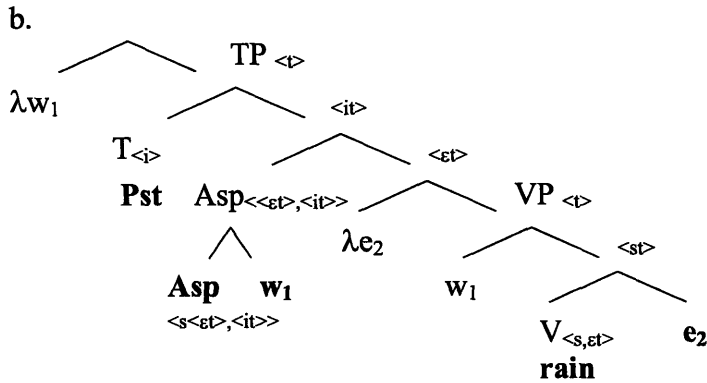

c. $\exists e[e \text{ in } w^* \ \& \ \tau(e) \subseteq t \ \{t <t^*\} \ \& \ \text{rain}(e)]$

Aspect takes a world, a predicate of events, and a time. In the above example, the only world binder is the one provided by the syntax; both world pronouns get bound by it. In such simple cases, having the world argument in the restriction will be indiscernible from not having it (as in the Kratzer version). However, as we will see shortly, when the aspect moves above a modal element, the world variable in its scope will have to be bound by the binder provided by that modal element, while that of the restriction will have to be bound by a higher (matrix) binder (as would be the case for (69)).

If this proposal is on the right track, we observe a crucial difference in the binding conditions that apply to quantifiers over events vs. quantifiers over individuals: it appears that the world argument of the event quantifier's *restriction* also obeys some locality principle, and thus needs to be bound by its closest binder. This is a welcome result. Percus formulates his binding principles on a construction by construction basis. The further constraint we see here suggests that we could in fact reformulate Percus's binding principles in terms of a more general condition, stating that any world argument on the 'spine' of the tree (T, A, M, V) needs to be bound by the closest binder (K. von Stechow, p.c.).

Giving aspect a world argument has precedence in the literature. Landman (1992)'s analysis of the progressive essentially anchors an event to a world (the actual world in matrix contexts). According to Landman's analysis, in a progressive statement such as '*Jane is crossing the street*', there is an extensional element, namely an event e in the actual world which corresponds to a beginning *stage* of a larger event, which in some continuation branch (in some possible worlds) is the completed event of crossing-the-street. One way of recasting Landman's account to fit the current framework is to say that the 'extensional' component takes a world

pronoun, which, in matrix context is bound by a default binder (à la Percus). We will go into greater details of the analysis of the progressive in chapter 2.

So far, I have argued that event quantification should be amenable to an analysis which closely matches that of quantification over individuals: There are generalized quantifiers over events, which work in a similar fashion as generalized quantifiers over individuals. Verbs select for an event argument. When this event argument is a quantifier, the quantifier needs to move for type reasons to a position right below T. I assume that the syntax allows free merging order of T and Mod (the default hypothesis); when T is merged above Mod, then aspect will have to move above the modal, if T is merged below Mod, then Aspect will move right below T, but it won't move above the modal. This is, at least, what happens for perfective aspect. So far, I have assumed an analysis of the imperfective which closely matches that of the perfective, modulo the direction of the inclusion relation w.r.t. the reference time. As we will see in chapter 2, the semantics of the imperfective may be more involved. Indeed, the imperfective covers a wide range of cases: progressive, habituals, counterfactuals, generics, and it is not clear that we can find a single lexical entry for all of these uses. The lexical entry in (72)b) is most probably an unlikely candidate.

To sum up, the two crucial assumptions I am making are (i) aspect is anchored to a world (via a world pronoun that has to be bound); (ii) aspect has to move from its base-generated position as an argument of the verb for type reasons. This movement can target a position above the VP or above the modalP (depending on where T is w.r.t. a modal). In the case of the latter, the aspect's event argument will have to be bound by the default matrix binder, forcing the event to be part of the actual world.

One final remark. In this section I have tried to push the parallel between events and individuals and to standardize quantification. However, the analogy breaks down in the syntactic assumptions required for each. While quantifiers over individuals move for type reasons, they do so covertly, via Quantifier Raising (QR):

(74) Some boy insulted every girl.

To get inverse scope (i.e., *for every girl, there is a (different) boy who insulted them*), it is assumed that *every girl* moves covertly to a position where it has scope over *some boy*. In the event domain, however, I take aspect to move overtly. Specifically, I assume that Aspect is a

head, which moves by head movement, and merges right below Tense. As far as I can tell, there is no reason why head movement couldn't be semantically motivated (by type reasons).

2.2. DERIVING THE IMPLICATIVE READING OF ROOT MODALS

Taking stock of what we have so far: The different interpretations of modal auxiliaries share a semantic core: they involve the same lexical items (cf. Kratzer 1981, 1991), and their differences arise from a combination of contextual and structural factors to which we will return to in chapter 3. What is crucial for this section is that only root modals scope under aspect, and hence yield actuality entailments. Perfective aspect is a quantifier over events; it is base-generated as an argument of the verb, a position from which it needs to move out of for type reasons. When it moves above the modal, it yields an actuality entailment. Let's see how:

(75) a. Jane could-pfv run

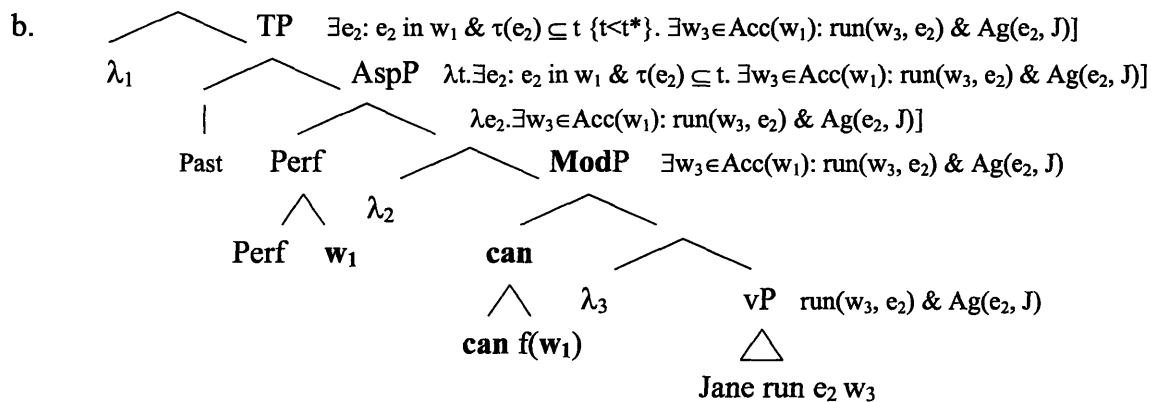

c. $\exists e_2[e_2 \text{ in } w_1 \ \& \ \tau(e_2) \subseteq t \ \{t < t^*\}]. \exists w_3 \in \text{Acc}(w_1): \text{run}(w_3, e_2) \ \& \ \text{Ag}(e_2, J.)]$
'There is an event in w^ located in a past interval, and there is a world compatible with $J.$'s abilities in w^* where that event is a running event by $J.$ '*

Perfective aspect is base-generated as an argument of the verb, but needs to move out to combine with a time pronoun sitting in Tense. In this case, it will move above the modal. There are two world binders in the structure, the one introduced by the modal (λ_3) and the default matrix one (λ_1), as assumed in Percus 2000. The world argument of the perfective has no choice but to be bound by the latter, given that it is above the modal. This will yield an *actual* event, which in some possible world is a running event by Jane.

What is this actual event? We know from the way it is bound that it is the same event in w_3 as in w_1 . This is not enough. How does the inference that Jane **ran** in the actual world come

about? Or, in other words, how is it that we (speakers of French and Italian) take the event in the actual world, which is a running event in some world, to be a running event in the actual world as well? Basically, events have some essential properties that they share across worlds. What these essential properties are will be whatever properties allow us to identify the event as a running event in the first place. Because it has these properties in some world, it will have these properties in all of the worlds in which it occurs, and thus, crucially, in the actual world. We will hence have to identify it as a running event in the actual world. If a (complete) event is a P-event in a given world, then in every world in which it occurs (in its entirety), it will be a P-event there as well. I will thus argue for a principle of event identity across worlds:

(76) Event Identification across Worlds (version 1):

For any w_1, w_2 : If an event e occurs in w_1 and w_2 ,
and e is identifiable as a P-event in w_1 ,
it will be identifiable as a P-event in w_2 as well.

The actuality entailment comes about as follows: In (75), we know that e_2 occurs in w^* (the event is bound in the actual world). We further know that e_2 is a running event in some world w . We therefore conclude that e_2 is a running event in w^* (given (76)). The prediction that this account makes then is that because (i) existential closure is outside of the scope of modal, and (ii) events retain their essential properties across worlds, whenever aspect scopes over the modal, we should get actuality entailments¹⁵. The question will then become where do the non implicative readings with the imperfective come from, a question to which we will return in chapter 2. In the next section, I would briefly like to address the matter of cross-world identify.

2.3. EVENT IDENTIFICATION ACROSS WORLDS

As we saw in section 2.1, postulating events in one's ontology has been an intuition-friendly device to handle entailment patterns from sentences such as *Brutus killed Caesar with a knife* to *Brutus killed Caesar* (cf. Davidson 1967). Although events are a very intuitive notion, their characterization turns out to be very difficult to pin point. Adding events in the ontology faces important philosophical questions. What kind of entities are they? Do they differ from material objects? Are events particulars or universals? Concrete or abstract? What are their identity and

¹⁵ These two crucial ingredients for deriving actuality entailments originated from suggestions by Irene Heim, pc.

identification criteria? What is their place in a causal network (Pianesi and Varzi, 2000)? The main challenge for a theory of events is to give an identity condition on events: when will two events be the same event?

Davidson's original theory was that two events are identical if they have the same causes and effects. However, the circularity of this definition led him to ultimately reject it: what are causes and effects if not events? Siding with Quine, he then proposed that events are identical if and only if they occur in the same space at the same time. One major problem with this account arises with the following kind of example. Imagine a sphere which is rotating and heating up at the same time: the heating and rotating of the sphere completely overlap in time and space, but yet our intuitions tell us that we are dealing with two events and not just one. Lewis' proposal (1986) doesn't suffer from this problem: His definition of an event is that it is an event only if it is a class of spatio-temporal regions both this-worldly (assuming it occurs in the actual world) and other-worldly. This handles the heating and spinning problem since the cross-world spatio-temporal profile of the two events is not identical: even if in some world, the heating and spinning occur in the same location, there is a world in which there is heating but not spinning on one location (the spinning will be at another location), and so they aren't the same event.

Note that definitions of event identity really concerns events occurring in the same world: in Lewis' account, if there is an event e_1 of running in world A but that in another world B, there is no running, but only walking, e_1 just won't occur in B (or rather, there won't be counterparts of e_1 in B). However, if (counterparts of) the same event occur across two worlds, then we expect that they will have the same essential/defining properties in both worlds. This is the notion I am appealing to in this account: if an event e_1 is a running event in world A, then in all of the worlds in which it will occur, it will be a running event there as well.

Linguists may not be as bothered as philosophers by the spinning and heating example: why not say that the spinning and heating *are* the same event? Portner (1998) for instance, argues in his analysis of the progressive that *Jane crossing the street* and *Jane walking into the path of an incoming bus* are the same event, under two different descriptions. But this may simply be a matter of opinion. From a more linguistic point of view, it seems that the notion of *telicity* applies to properties of events, and not to events themselves (K. von Stechow, p.c.): Imagine that Jane is walking to school and reaches the school, and that the whole process takes 10 minutes. Arguably, walking to school and walking for 10 minutes are a single event. However,

walk to school is telic, but walk for 10 minutes isn't. But then again, we could say that we are dealing with two events, with different cross-world profiles: in some worlds, Jane may have walked for 10 minutes without reaching the school, while in some others she may have walked to school, but it would have taken her half an hour. The first event would be atelic, the second telic. It may be very difficult to decide between the two possibilities. If indeed, in these cases, we are dealing with a single event, which can be described as a P_1 event (e.g., crossing-the-street) or as a P_2 event (e.g., walking-into-the-path-of-a-bus), we may need to reformulate our event identification principle, in a way that won't prevent 'actuality entailments'. One possibility is that, everything else being equal, if an event happens in two worlds, and its properties are such that we 'label' it as a P event in w_1 , then, everything else being equal, we will label it as a P event in w_2 as well.

What do I mean by everything else being equal? We just saw instances where, it is arguably possible to give the same event two different descriptions (and thus assign them different properties). This raises the further question of which properties are essential (i.e., underlyingly present in both descriptions of the same event), and which aren't? This is a very difficult philosophical question. Many philosophers express skepticism about the possibility of identity across possible worlds. Chisholm (2002) for instance discusses an example where we take an individual, say Adam, in our world, and change him very slightly in world 2, for instance, take out one of his hair. Presumably, he remains the same person in both worlds. But, once we accept this and because of transitivity of identity, we're led to accept that Adam is Noah and Noah is Adam, after both undergo a series of slight (unperceivable) changes of their properties until Adam becomes Noah and Noah becomes Adam in a particular world. Chisholm argues that the only way to 'countenance identity through possible worlds and avoid such extreme conclusions is to appeal to some version of the doctrine that individual things have essential properties'. The problem with such a move, Chisholm argues, is that we have absolutely no way of finding out what these properties are, nor even figure out whether an individual has essential properties at all, so why should we assume that he does?

It might, indeed, prove to be a very difficult task to identify precisely which property of an event, or of an individual for that matter, is essential. However, we can at least acknowledge that there is something, call it essential property or something else, which enable us to 'label' this event: it is whatever allows us to agree in most cases to call a running event a running event.

Still, there are cases where we do disagree or misidentify events. Consider the following example:

(77) Bill mistakenly thought that Mary's wedding was a funeral. [Kai von Fintel, p.c.]

A comparison with objects is in order. One way to interpret my proposal is that I am treating the event *de re*: the event is somehow both outside and inside the modal. What we learn from *de re* interpretations of objects/individuals is that they can be thought of in many different guises. We know that a sentence like *Darcy wants to marry a plumber* is ambiguous. Either Darcy wants to marry someone or other who is a plumber (the *de dicto* reading). Or, Darcy is in love with a particular person, say Lizzie, who happens to be a plumber (the *de re* reading). This *de re* reading is true even if Darcy, in fact, thinks that Lizzie is a pianist. The property that allows us to identify Lizzie in the actual world is 'being a plumber', but she doesn't have to be one in any of Darcy's thoughts. Now, if *events* also come in many different guises, how could we possibly force them to keep the same description across worlds, which is what we needed to derive actuality entailments? This is where, I think, the modality involved plays a role. The *de re* multitude of guises issue comes about with those attitudes or modals which bring with them the perspective (epistemic state) of someone other than the speaker (e.g., the attitude holder). With root modals, however, the epistemic state of the subject doesn't enter the equation. In the sentence '*Darcy can impress a plumber*' (with 'a plumber' interpreted *de re*), it doesn't matter if Darcy thinks he is trying to impress a pianist. The sentence will be judge true if it is demonstrated that Darcy can in fact impress an *actual* plumber.

Going back to our event identification principle, we see that, so far, we have been looking at actuality entailments with *root* modals. Given that the subject's perspective is inconsequential, we can safely assume that the same event will keep the same guise (which is ascribed by the same person, at the same time, in the same world—the speaker at t^* in w^*) across different worlds; there is no change in perspective. Enters Italian *want* (*volere*). As we will see in chapter 4, *volere* (unlike its French and English counterpart) yields actuality entailments with perfective aspect:

(78) Jane ha voluto parlare a Elisabeth, #ma non lo ha fatto.
Jane wanted-pfv talk to Elisabeth, # but she didn't do it

In chapter 4, I propose an analysis for *volere* similar to the one here for root modals. Notably, I treat *volere* as a modal, which allows Aspect to move above it, from its base position in the complement, to the matrix T above *volere*. Aspect thus binds its trace across the modal element, anchoring the event in the actual world. One crucial difference with root modals is that the modal base involved with *want* picks out the *belief*-worlds of the subject (further ordered by his desires) (cf. Heim 1992, von Stechow 1999). Interestingly, with *want*, we are able to build scenarios where the same event doesn't receive the same description in the actual world, as it does in the subject's *belief* worlds. Imagine that Darcy's dream has always been to marry a billionaire. However, upon seeing Jane rummaging through his garbage, he is struck with love; a couple of weeks later, he proposes, despite thinking that she is a homeless person, and they get married. Unbeknownst to him, Jane is of course an eccentric billionaire, who likes to go through trash. Jane is a billionaire in the actual world, but a homeless person in all of Darcy's belief/desire worlds. In English (and in French), there are two ways to report the situation (after his falling in love with Jane). In (a) below, Darcy wants to marry Jane, who he mistakenly takes to be a homeless person. In (b), the billionaire is read *de re*: Darcy wants to marry Jane, who happens to be a billionaire *in the actual world*:

- (79) a. Darcy wanted to marry a homeless person.
 b. Darcy wanted to marry a billionaire.

Once we turn to *volere* with perfective, we see that (i) we get an actuality entailment (there was a marrying event by Darcy); (ii) the reading in (b) is blocked:

- (80) a. Darcy ha voluto sposare una barbona.
 Darcy want-pfv marry a homeless person
 b. # Darcy ha voluto sposare una miliardaria.
 Darcy want-pfv marry a billionaire

What's interesting for our purposes here, is that the event description is not the same in Darcy's belief/desire worlds—where it is a *marry a homeless person* event—as it is in the actual world—where it is a *marry a billionaire* event. In this case, the description of the event in the belief worlds prevails. So here we have a case where our event identity principle runs into a dilemma. How do we resolve it? The truth conditions for (80)a) are as follows: *there was an event in the*

actual world, such that in all of Darcy's belief worlds, it is a marrying a homeless person event. What is this actual event? It is still a marrying event by Darcy, of a person, Jane (which he happens to think is a homeless person). We copy as much of the event description into the actual world as our information permits us.

Importantly, with a root modal, the identification principle behaves differently. With a circumstantial modal base, the subject's beliefs don't enter the equation. Thus, with the above scenario, only the *marry a billionaire* event can be reported with a perfective root modal:

- (81) a. #Darcy a pu épouser une clocharde.
Darcy could-pfv marry a homeless person
- b. Darcy a pu épouser une milliardaire.
Darcy could-pfv marry a billionaire
- c. '*There is an actual event, which in some world compatible with the facts and circumstances in w^* is a marrying a billionaire event.*'

In all circumstantially accessible worlds, Jane is a billionaire, and so is she in the actual world, it is a fact of the base world. Darcy's beliefs are not factored in.

To sum up, in most cases of actuality entailment, we will infer that the *actual* event shares all of the properties associated with its description in the accessible worlds, except in cases where the information in those worlds clashes with what we have in the actual world. These cases won't come up with circumstantial modals, given that the circumstances of the events will be the same, including properties of the subject and the object.

Thus the principle of event identification underlying actuality entailments could be recast as the inference mechanism below. This version will only matter in cases where the modal base is not realistic:

(82) **Event Identification Across Worlds (version 2):**
For any w_1, w_2 : If an event e occurs in w_1 and w_2 , and e is described as a P event in w_1 by individual x , individual y should transfer as much of P in w_2 as is compatible with y 's own knowledge.

I would like to close this section by making a quick comparison between the event that is given by the perfective and the 'extensional element' of Landman's Progressive. In his analysis,

the extensional component is a *stage* of an event in the actual world. With the perfective, the extensional component is an *entire* event whose properties are not directly specified in the actual world but rather in some accessible world.

It is crucial for the event in its entirety to happen in the actual world (this presumably comes from the temporal restriction, which places the running time of the *entire* event within the reference time). When we look at complex events, such as achievements, the actuality entailment includes the culminating point, not just the process. Consider the following example:

- (83) Lizzie a pu peindre un tableau.
Lizzie could-pfv paint a picture

(83) is false if Lizzie painted parts of a picture but didn't finish it. To ensure that the whole event happens in the actual world, the existential quantification has to be done over the largest event in its entirety. The precise decomposition of achievements is a matter of lexical semantics (e.g., is there a complex event, or a pair of events?). For our purposes, whatever mechanism is responsible for understanding an achievement as having culminated with perfective aspect, as in '*Lizzie a peint un tableau*' (*Lizzie has painted a picture*) will handle our modalized case in (83).

2. 4. INTERACTION WITH NEGATION

I have proposed that aspect moves above the modal, and below tense. How does it interact with negation? We might expect a scope ambiguity between the existential quantifier over events and negation. However, it seems that we only get one interpretation. Consider the following examples:

- (84) Darcy n'a pas pu s'enfuir.
Darcy NE has can-pfv escape.
'Darcy wasn't able to escape'

It seems that negation is interpreted above aspect, as in (a). The meaning in (b) is unattested (in fact I am not sure what it would mean):

- (85) a. There was no event s.t. in some accessible world it is an escaping event by Darcy
⇒ There was no escaping in the actual world, nor in any accessible worlds.
b. There was an event e s.t. in no accessible world e is an escaping event by Darcy.

Why should that be? Negation is supposed to be high (somewhere between T and A), and the fact that aspect cannot pass T might suffice to rule (b) out. But this might be contingent on our theory of Tense (and negation). Another possibility to rule (b) out is that it might be uninformative beyond salvation: all (b) says is some event occurred, and in no accessible world was it an escape: there are more parsimonious and less misleading ways to say ‘something happened’. Note that it is possible to have a low negation overtly, as in ‘*Darcy a pu ne pas s’enfuir*’ (*Darcy could not-escape*), which roughly means ‘*Darcy was able to avoid escaping*’, but this is simply a case of constituent negation.

2.5. IS THE MODALITY DETECTABLE?

Recall from the introduction that there was a question of whether the modality completely disappears in the presence of perfective morphology. We now see that the modal is still there, and that the actuality entailment arises because the event is bound in the actual world. One question that comes up is whether the presence of the modal goes undetected or not. In order to see that the modality is still present, and truth-conditionally detectable, we need to turn specifically to goal-oriented interpretations.

2.5.1. *The Case of Goal-Oriented Modals*

Goal-oriented modals differ from ability modals in (at least) three respects: first of all, they involve a purpose clause (the goal). Secondly, while both types of modals involve circumstantially accessible worlds, the meaning of an ability, as is commonly understood, primarily involves physical and mental capacities, while a goal-oriented interpretation might be more sensitive to surrounding factors, rather than intrinsic factors. Finally, while there is a clear dual to goal-oriented possibility (*can*), namely goal-oriented necessity (*must*), there is arguably no such dual for the ability modal (cf. Hackl 1998, for why there is no dual to ability *can*). However, there are borderline cases which make it difficult to give a categorical distinction between the two: sometimes, it appears that an ability relies more on extrinsic properties (e.g., *Darcy can see Lizzie from where he stands*). Moreover, one can always imagine an implicit purpose clause with every ability modal construction, some sort of justification for one’s actions: one doesn’t just randomly lift tables: maybe one is trying to impress someone else, or trying to

test one's abilities, etc... What links these two modals, as well as purely circumstantial modality (involved in examples such as '*hydrangeas can grow here*') is precisely that they involve circumstantial modality. This type of modality is used 'when we are interested in the necessities implied and possibilities opened up by certain facts'. 'Circumstantial modality is the modality of rational agents like gardeners, architects or engineers' (Kratzer 1991), it has explanatory power. In uttering a sentence such as '*I had to sneeze*' one does more than simply state a fact (the fact that I sneezed). What the modality contributes is a sort of explanation (Kai von Fintel, pc): the circumstances at that time (it is the beginning of allergy season, I am outdoors, pollen is flying around my nose, etc...) explain the inevitability of my sneezing: in all of those worlds in which these circumstances hold, I sneeze.

Where does the explicit purpose clause fit in? Following von Fintel and Iatridou (2004a)¹⁶, I take the purpose clause to be an argument of the modal, which further restricts the *modal base*. Note in passing that, so far, I have ignored the ordering source, which plays an important role in the data von Fintel and Iatridou want to account for. For our purposes, it is still fine to ignore it at this point: if an event happens in some best accessible world, rather than some (plain) accessible world, and is an event with a set of essential properties P in that world, then, in the actual world where it also happens, it will have the same set of properties.

- (86) a. Jane a pu prendre le train pour aller à Paris.
 b. $\exists e[e \text{ in } w^* \ \& \ \tau(e) \subseteq t \ \{t < t^*\} \ \& \ \exists w' \in \text{Acc}(w^*) \ \& \ \text{J-go-to-Paris in } w']$: take-train(w')(e)(J)]
 c. 'There is an event in the actual world contained within an interval in the past, and there is a circumstantially accessible world where Jane goes to Paris in which that event is a taking the train event by Jane'
- (87) a. Jane a dû prendre le train pour aller à Paris.
 b. $\exists e[e \text{ in } w^* \ \& \ \tau(e) \subseteq t \ \{t < t^*\} \ \& \ \forall w' \in \text{Acc}(w^*) \ \& \ \text{J-go-to-Paris in } w']$: take-train(w')(e)(J)]
 c. 'There is an event in the actual world contained within an interval in the past, and in all circumstantially accessible worlds where Jane goes to Paris, that event is a taking the train event by Jane'

¹⁶ von Fintel and Iatridou (2004a) are primarily concerned with goal-oriented modal statements of the form '*If you want to go to Paris, you have to take the train*', which comes with its set of complications having to do with the composition of the if-clause and *want*, that I won't cover here. What matters for our purposes is that they assume that goal-oriented constructions of both types have a purpose clause (explicit or implicit) as an argument of the modal, which I do here as well.

One question that may come to mind is whether, when we get an actuality entailment, the goal also has to hold in the actual world. Data suggest that it may not need to¹⁷:

- (88) Jane a pu prendre l’avion pour aller à Londres, mais l’avion a été détourné vers Manchester, et elle n’est jamais arrivée à Londres.
Jane could-pfv take the plane to go to London, but the plane got rerouted to Manchester, and she never reached London.

In (88), it is definitely entailed that Jane took the plane. Any continuation that would deny this would be a contradiction. However, the continuation here suggests that the goal doesn’t have to be reached in the actual world. This is actually what the account predicts. From the cross-world event identification principle we get that in the actual world the event is a taking the plane event. However, while in *some* world this event holds **and** Jane also goes to Paris, the purpose clause restricts only the modal: it doesn’t have to hold in the actual world.¹⁸

Going back to the truth conditional contribution of the modals, we see that (86) and (87) happen to differ truth conditionally in a scenario where Jane had other options for going to London (e.g., taking the plane, riding a horse, etc.). In this scenario, (86) will be true, and (87) false. The reason why the latter is false is that in *all* of the worlds which are circumstantially available and where Jane goes to London, she takes the train. There is thus no accessible worlds in which she reaches her goal but doesn’t take the train, i.e., there is no possibility to ride a horse or take a plane...

¹⁷ Speakers may differ on whether the goal has to obtain in the actual world. My French informants all agree with the judgment in (88). Italian speakers split into two groups. I won’t explore what underlies this split in acceptance, and simply suggest that it may have to do with the way the purpose clause is interpreted. Note that when it is fronted, the judgment gets degraded, but still acceptable for speakers that accept (88).

¹⁸ Nissenbaum (2005) offers a slightly different analysis than von Stechow and Iatridou, where the purpose clause is merged directly with the complement, that is, (87) should be parsed as ‘*Jane had to [take the train to go to Paris]*’:

- (1) a. $\exists e[e \text{ } o \text{ } w^* \ \& \ \tau(e) \subseteq t \ \{t < t^*\} \ \& \ \forall w' \in \text{Acc}(w): [\text{take-train}(w', e) \ \& \ \forall w'' \text{ compatible with the goal of } e, \text{ J. goes to Paris in } w'']]$
b. ‘There is an event in w^* contained within an interval in the past, and in all circumstantially accessible worlds, that event is a taking the train by Jane with the goal of going to Paris’

Here as well and because the purpose clause is modalized, the goal also doesn’t have to hold in w^* , simply because the event described by the complement obtains. Thus, as far as our data is concerned, either account will do.

2.5.2. Root Modals and Implicatures

We thus see that we get a truth conditional difference between a universal and an existential modal, even when we have an actuality entailment. While both require that the event in the complement take place *in the actual world*, as for the unmodalized version in (a) below, the necessity modal further requires that it takes place in all accessible worlds. In other words, Jane has no choice.

- (89)
- a. Jane a pris le train pour aller à Paris.
Jane took-pfv the train to go to Paris
 - b. Jane a pu prendre le train pour aller à Paris.
Jane could-pfv take the train to go to Paris
 - c. Jane a dû prendre le train pour aller à Paris.
Jane had to-pfv take the train to go to Paris

There is one additional meaning component involved in (b), namely, we feel that taking the train was Jane's **preferred** mean of transportation. No such inference arises with (a) nor (c). Another impression informants report for (b) is that Jane didn't expect to be able to take the train at first, but that option became open, so she jumped on it, again matching the intuition that taking the train was a desirable outcome. Note that similar intuitions accompany the ability modal:

- (90) Jane a pu soulever cette table.

In (90) we get the impression that Jane's being able to lift the table was somewhat unexpected (she just recovered from a broken arm, or the table is particularly heavy). Bhatt (1999) captures this intuition for the ability modal by stating that ABLE comes with a conventional implicature that some effort is involved with the realization of the complement.

In the present account, how can we cash out these intuitions? Where does this desirability inference come from? It seems that this desirability component is an implicature, which can be cancelled:

- (91) She was able to take the train. In fact she would have preferred to fly, but there was no other way to go to Paris.

The implicature would arise as follows¹⁹: *can* and *must* are scalar alternatives, with *must* being the stronger of the two, given that *must p* entails *can p*. Upon hearing (89)b), one will infer that the speaker is not in a position to assert ((89)c). Thus, he will infer that there are accessible worlds in which Jane goes to Paris but where the event of taking the train doesn't happen, further implying that there are other ways for Jane to reach her goal of going to Paris (i.e., there are other accessible worlds where Jane goes to Paris which do not have a taking the train event). He will then deduce that Jane had options. Because she took the train, while having options, taking the train must have been preferable. The unmodalized (a) doesn't have a competitor, hence no such inference arises. Similarly for the ability modal, because the modal is existential, we infer that there are accessible worlds, where Jane has the abilities that she has and the circumstances are the same, where there is no event of lifting the table, which implies that the event described by the complement is not a trivial outcome.

3. PREVIOUS PROPOSALS

In this section, I would like to compare my proposal to previous ones in the literature. The two proposals I am aware of come from Bhatt (1999) and Piñón (2003), which both deal with the ability modal²⁰.

3.1. BHATT (1999)

Bhatt (1999) was the first to discover that the ability modal is implicative with perfective morphology, and non implicative with imperfective, in languages that have an overt morphological distinction²¹. In his analysis, the ability modal is at base implicative, with the semantics of an implicative predicate like *manage*, meaning that what is being asserted is the complement clause itself (following Karttunen's (1971) analysis of implicatives). In order to derive the full meaning of this construction, Bhatt proposes a conventional implicature, parallel to that of *manage* (cf. Karttunen and Peters 1979), which states that some effort went into the realization of the complement clause. This yields the implicative reading associated with perfective morphology.

¹⁹ Following a suggestion by I. Heim.

²⁰ It has recently been brought to my attention that Borgonovo and Cummins are currently working on this issue. I will wait until the completion of their paper, to evaluate their proposal.

²¹ Thalberg (1972) was the first to note an ambiguity between an 'ability' and an implicative reading, see also Karttunen (1971); however, neither of them linked the difference in behavior to aspect.

- (92) Jane a pu soulever la table.
 Jane could-pfv lift this table
 ABLE(lift-this-table)(Jane)
Assertion: Jane lifted this table
Implicature: Some effort was involved in lifting this table

For the modal reading Bhatt takes the imperfective morphology to reflect the presence of a generic operator (GEN), based on morphological evidence in Hindi, and on generic readings of bare plurals in English. We will review this evidence in chapter 2. This generic operator has been argued not to require verifying instances (cf. Krika *et al.*, 1995). For instance, the sentence ‘*This machine crushes oranges*’ is analyzed as having a generic operator quantify over ideal situations of using the machine. Because such ideal situations might not have ever occurred in the actual world, we will judge the sentence to be true, even if the machine has never been used before. In other words, the sentence doesn’t require actual instances of this machine crushing oranges. Going back to the ability modal, Bhatt argues that when GEN is present (imperfective morphology), the complement clause doesn’t need to be actualized. His analysis is represented below:

- (93) Jane pouvait soulever la table.
 Jane could-pfv lift this table
 GEN(ABLE(lift-this-table))(Jane)

Because GEN doesn’t require verifying instances, in (93), Jane doesn’t need to have lifted the table for the sentence to be true (as long, presumably, as there are—non-actual—situations or worlds that satisfy the restriction of the genericity operator, in which she does lift the table).

One setback in Bhatt’s proposal is that his treatment of the ability modal doesn’t allow any connection with other interpretations of the same modal. There is no way to relate his analysis of ABLE to epistemic and deontic possibility, which, for instance in French, is expressed using the same lexical word, i.e., *pouvoir*. If we followed Bhatt’s account, we would essentially have to treat epistemic *pouvoir* and ability *pouvoir* as two homonyms. More suspicious is the fact that this lexical ambiguity is to be found in language after language: the same lexical item is used for deontic, epistemic or circumstantial possibility²². One may argue, however, that more and

²² Thanks to Sabine Iatridou, p.c.s for insisting on this point.

more analyses of different modal constructions give each of them a unique treatment (cf. MacFarlane, 2003 for epistemics; Ninan 2005 for deontics, etc...), and it may turn out that the homonymy problem is more of a polysemy problem: two modals would still perform similar functions and while they may be listed as distinct entries in the lexicon, they could share a common etymology. Interestingly, a similar controversy arises with analyses of the imperfective, which, cross-linguistically, covers different meanings (progressivity, habituality, counterfactuality...). While some authors try to give a common meaning to a couple of uses (cf. Ferreira 2004, Cipria and Roberts 1997), most give independent accounts for each interpretation. Still, a major advantage of Kratzer's account of modals is that it derives their meaning difference through contextual factors (the conversational backgrounds), which intuitively makes a lot of sense. One would prefer a unified account, if available, to one that takes as completely accidental the fact that, cross-linguistically, the same lexical items have the same range of meanings.

Furthermore, given that goal-oriented modals follow the same pattern, we need an account that will apply to the two modal senses in any case. And even if we could extend this proposal to the goal-oriented cases, by treating both the possibility and the necessity modals as underlyingly implicative predicates, it is not clear how we could then possibly derive truth-conditional differences between the possibility and the necessity modals, as the ones we saw in section 2.4. (Both would be implicative predicates, and whatever meaning differences would have to be on the implicature/presuppositional level.)

The present account avoids these problems: it allows the ability modal to have an implicative meaning with perfective morphology, while keeping a connection with the other senses of a possibility modal: it is still an existential quantifier over possible worlds. The crucial difference between the ability modal and the epistemic possibility modal is structural: one scopes below and the other above aspect (cf. chapter 3). However in both of its senses, the possibility modal (*pouvoir*) refers to some possible world among a set of accessible worlds, this set being determined by context. Thus we maintain the benefits of a Kratzerian account, while accounting for Bhatt's data.

Another problem with Bhatt's account, which he points out himself, is that we may expect that when real implicatives (like *manage*)—which share the same semantics as Bhatt's ABLE—combine with imperfective morphology, they should lose their implicative behavior (no actuality entailment). But, as the following example shows, this is not so:

- (94) Darcy réussissait à soulever cette table, #mais il ne la soulevait pas.
Darcy succeed-imp to lift this table, #but he didn't lift-impf it.

Bhatt's suggestion is that there are two sorts of genericity operators, a 'Universal' and a 'Dispositional' one, and only the latter does not require verifying instances. However this is a reformulation of the problem: why it is that real implicatives can only combine with a universal genericity operator?

Again, the present account is shielded from this sort of criticism, since my semantics for the modal is not that of an implicative predicate: the implicative reading is inferred from a combination of factors: a mechanical one (existential closure occurs above the scope of the modal) and a condition on event identity. In the next chapter, we will focus on the non implicative readings of the root modals. We will see that while GEN is responsible for some non implicative readings (as in Bhatt's account), not all non implicative readings can invoke GEN.

3.2. PIÑÓN (2003)

Piñón (2003) offers an interesting proposal for the two uses of English *able* which he identifies as an 'opportunity-able' and an 'ability-able', and which correspond to the implicative and non implicative uses of the ability modal. He proposes to derive the implicative readings of English *able* through scopal differences between a possibility modal and a past tense. Piñón suggests that for opportunity-able, we are dealing with a historical possibility, where the modality is trivialized as it scopes above a past tense (if it is *historically* possible that past p, then it has to be the case that past p). For reasons of space, I won't give a full account of the proposal and refer the interested reader to Piñón 2003. I will simply point out a few challenges that his proposal faces if we try to extend it to our modal auxiliaries. First, Piñón doesn't relate the implicative behavior with aspect, so it is not clear why perfective would always yield actuality entailments, but not imperfective aspect. Second, it is not clear either how to extend this proposal to the goal-oriented cases (although the modality there could also be argued to be historical possibility/necessity). Third, the strength of the proposal is that it derives the implicative reading solely from a difference in scope. There is a wrinkle to this proposal however, in that the two readings do not

strictly differ in terms of scope: implicative/opportunity *able* takes Tense as an argument, while ability *able* doesn't²³:

- (95) a. $\text{able_a} = \lambda R \lambda x \lambda \langle t, h \rangle [\diamond(\langle t, h \rangle, \text{agent}(x, R))]$
 b. $\text{able_o} = \lambda T \lambda R \lambda x \lambda \langle t, h \rangle [\diamond(\langle t, h \rangle, T \text{agent}(x, R))]$

4. CONCLUSION AND LOOK-AHEAD

In this chapter I have showed how to derive actuality entailments when perfective aspect moves above the modal²⁴. I have argued that the entailment comes about because aspect comes with its own world variable, which has to be bound by the matrix world binder, given that it appears above the modal. This yields an actual event. We then infer that that event has the same properties in the actual world as it does in the accessible worlds in which it also occurs. This happens via some default identification principle, at work when looking at events across worlds. In the following chapter, I will show how to avoid actuality entailments with imperfective aspect. I will essentially propose, following Bhatt, that imperfective reflects the presence of an extra modal component, which thus prevents an actual event. In chapter 3, I will motivate the relative position of aspect w.r.t. the different interpretations of the modals. I will relate this positioning to other phenomena, and propose an amendment to Kratzer's semantics, which maintains a semantic core for all modal auxiliaries, but can explain the differences in syntactic and semantic behavior associated with each interpretation.

²³ Thanks to K. von Stechow for pointing this issue out.

²⁴ I have proposed that aspect is base-generated as an argument of the verb and moves up for type-reasons. The primary motivation for choosing this non standard view of aspect, was to push the parallel between events and individuals on the one hand, and maintain a single lexical entry for modals. As we will see, thinking in terms of movement will give us an interesting avenue to explore when we contrast the possible combinations of various aspects and modal interpretations in chapter 3. Note that my proposal would be compatible with a more standard view of aspect, where aspect would be base-generated under Tense. If this were the case, we would need to assume that modals come with two different types. Epistemics, which scope above tense and aspect would take propositions as their complements, while root modals, which scope under aspect, would take predicate of events as their complement. To make the proposal more uniform, we could say that modals have a Boolean semantics, they are of type $\langle \alpha, \alpha \rangle$, (where α is either $\langle st \rangle$ or $\langle e, st \rangle$), that is they either take propositions and return propositions, or they take predicates of events and return predicates of events. I leave a detailed comparison between the two possibilities for future research.

CHAPTER 2: IMPERFECTIVE AND NON IMPLICATIVE READINGS OF ROOT MODALS

0. INTRODUCTION

Root modals, such as *pouvoir* and *devoir* in French, yield what Bhatt (1999) has called ‘actuality entailments’ when they combine with perfective aspect (a), but they do not with imperfective (b). This pattern is illustrated in the examples below, where a continuation which denies the realization of the complement doesn’t yield a contradiction in (b), the way it does in (a):

- (96) a. Jane a pu prendre le train pour aller à Londres, #mais elle a pris l’avion.
Jane could-pfv take the train to go to London, #but she took the plane
- b. Jane pouvait prendre le train pour aller à Londres, mais elle a pris l’avion.
Jane could-impf take the train to go to London, but she took the plane

We saw in the previous chapter that the reason perfective morphology on root modals forces their complement to hold in the actual world is due to the fact that perfective is a quantifier over events, which has to move to a position right below T in order to combine with its time argument. When a modal is merged below tense, perfective aspect has to move above it. Because, in this configuration, perfective is outside the scope of the modal, its world argument is bound by the matrix world binder. It thus yields an actual event. We will see in chapter 3 why merging the modal below T yields a root interpretation while merging it above T yields an epistemic or deontic one. This chapter will now focus on how to derive the non implicative readings of root modals, associated with imperfective morphology.

Consider the following example, where a root modal with perfective is overtly embedded under another modal element (here the attitude predicate *think*):

- (97) a. Darcy pense que Jane a pu s’enfuir.
Darcy thinks that Jane can-PAST-pfv escape
‘Darcy thinks that Jane was able to escape’
- b. $\forall w'$ compatible with D’s beliefs in w^* : $\exists e: e \text{ in } w' \ \& \ \exists w'' \in \text{Circ}(w')$: $\text{escape}(e, J, w'')$
‘In all worlds w' compatible with Darcy’s beliefs in w^ , there is an event which in some world w'' compatible with Jane’s abilities in w' is an escaping event.’*

The above sentence doesn’t make any claim about whether Jane escaped or not in the actual world, but, rather, makes a claim about an escaping event by Jane in Darcy’s belief worlds. We

see that, even when aspect moves above the existential modal (following the proposal in the previous chapter), aspect's world argument is still not bound by the matrix binder, but rather by the world binder provided by the attitude: hence no claim is made about an actual event. This kind of examples suggests that the presence of an extra modal element removes actuality entailments with root modals. In this chapter, I would thus like to explore the hypothesis that the lack of actuality entailments of root modals with imperfective aspect is due to an additional modal element reflected by imperfective morphology. This is, in fact, what Bhatt (1999) argues for in order to derive the 'modal' readings of ABLE. For Bhatt, the modal element responsible for the non-implicative or 'modal' readings is a Generic Operator (GEN), which, cross-linguistically, is associated with imperfective morphology. As we will see shortly, not all non implicative readings of root modals can be argued to involve genericity. However, these other non implicative readings can also be argued to involve some extra modal element, also associated with imperfective morphology.

Many accounts of the imperfective, in fact, involve some modality. However, it is not obvious whether we can pinpoint a single modal element for the various modal readings associated with the imperfective. It is not clear either whether this modal element should be wired in the semantics of the imperfective or whether it selects, or is selected by, the imperfective. In Romance, some of these modal interpretations include the progressive, habituais, genericity, counterfactuality, the imperfect of play, of politeness, the oeneric imperfect, etc... While several accounts have successfully given a unified account of the progressive and the habitual (cf. Bonomi 1995, Cipria and Roberts 2000, Ferreira 2005), no one has, as far as I am aware, successfully proposed a semantics of the imperfective that covers *all* of its uses. The question then becomes whether a unified semantics is attainable, or whether imperfective morphology is simply a semantically-vacuous default morpheme, which appears in all cases where the perfective doesn't (i.e., an 'elsewhere' morpheme).

In section 1, I will go over the non implicative readings of root modals that we need to account for. Section 2 surveys the various uses of the imperfective in general. In section 3, I will show that its incoherent distribution is best captured by treating it as a vacuous morpheme. I will then spell out the conditions that warrant the presence of imperfective morphology rather than perfective. I will argue the perfective and imperfective morphemes (in French and Italian) are two phonological spell-outs of a past tense, whose distribution essentially depends on whether a

modal or aspectual element intervenes between the tense and the quantifier of events. Finally, in section 4, we will go back to the non implicative readings of the root modals, and show how to derive them.

1. NON-IMPLICATIVE READINGS OF ROOTS: ABILITIES VS. COUNTERFACTUAL SITUATIONS

The generalization which originates from Bhatt's work on the ability modal, and which we observe across all root interpretations, is that a root modal with imperfective aspect doesn't yield an actuality entailment. For Bhatt (1999), this is due to the presence of a generic operator (GEN), as we saw at the end of chapter 1. In his analysis, the ability modal is an implicative predicate, like *manage*, which loses its implicative force in the presence of GEN (reflected by imperfective morphology). Because this operator doesn't require verifying instances, the complement clause doesn't need to have been actualized. His analysis is repeated below:

- (98) Jane pouvait soulever la table.
Jane could-pfv lift this table
GEN(ABLE(lift-this-table))(Jane)

Bhatt's evidence for claiming that genericity is at the heart of the non implicative readings of the ability modal relies on two facts. First, based on Hindi, he shows that the imperfective morphology on the ability modal reflects genericity, not progressivity. Hindi has two separate morphemes for progressive and genericity/habituality (contrary to e.g., French or Italian), and the latter is the morpheme that combines with the ability reading²⁵. Second, based on examples like (99) involving bare plurals in English, he shows that genericity is associated with the ability reading of *able* (b) (and not with the implicative one in (a)):

- (99) a. (Yesterday) firemen were able to eat 50 apples.
b. (Back in the days) firemen were able to eat 50 apples.

(99)a) favors a Past episodic interpretation in which the bare plural subject is existentially interpreted. With this interpretation, there seems to be an actuality implication (that there are firemen who ate 50 apples). (99)b), on the other hand, favors a generic interpretation, with a

²⁵ In Hindi, progressive on a root modal is marginal at best.

generically-interpreted subject (referring to *firemen* as a kind, cf. Carlson 1977). With this interpretation, there is no actuality implication, supporting the hypothesis that non implicative readings are associated with Genericity (as evidenced by the generic interpretation of the bare plural). Note that in French (and Hindi, etc.), (a) would be translated using perfective morphology, and (b), using imperfective.

We thus have some evidence that some of the non implicative readings of root modals may be due to genericity. Below are some other examples which are most naturally interpreted as describing long term abilities, which do not need to have been actualized:

- (100) a. Elisabeth pouvait parler aux singes.
Elisabeth could-impf talk to monkeys.
- b. Cette voiture pouvait faire du 250 km/h.
This car could-impf go 250 kph.

It may be difficult to assert that someone/something has such abilities without some concrete instantiations, but it is still possible. For instance, Elisabeth could be part of a tribe whose genetic makeup is such that she intrinsically has this property. For (b) we feel that the car was driven at a speed of 250 kph, maybe during some testing at the production facilities; however, some calculations may be sufficient evidence to claim that the car can go 250 kph without it ever having gone so fast. Thus, this GEN doesn't require verifying instances. Importantly, and whether the ability was instantiated at some point or not, when we embed either sentence in (100) in a larger context, we do not force an actual instantiation of the ability bound to the time and place under discussion, whereas we do when the sentence shows perfective aspect:

- (101) a. Hier on est allé au zoo avec les enfants. Elisabeth était particulièrement heureuse, parce qu'elle adorait les singes et qu'elle **pouvait** leur parler. Malheureusement, quand on est arrivé, tous les singes avaient déjà été transférés au nouveau zoo.
Yesterday, we went to the zoo with the children. Elisabeth was particularly excited because she loved monkeys and she could-**imp** talk to them. Unfortunately, when we arrived, all the monkeys had already been transferred to the new zoo.
- b. ...qu'elle adorait les singes et qu'elle **a pu** leur parler. #Malheureusement...
...she loved monkeys and she could-**pfv** talk to them. #Unfortunately...

While perfective forces an actual event of talking to the monkeys at the zoo (as in (b)), imperfective simply states that the ability held in a (large) time interval surrounding the trip to

the zoo, even if it wasn't instantiated (at the zoo) (as in (a)). A paraphrase, which highlights the genericity tied to this reading, is given below:

- (102) Whenever Elisabeth is with monkeys (and they feel like communicating, they're not sick, she hasn't lost her voice,...) she can talk to them.

Thus, ((100)a)'s most natural reading is that of a long lasting ability, which might have to be instantiated at some point, or at least there should be ways for knowing that she in fact has that ability. Note that if *monkeys* is interpreted existentially, then the preferred reading will be a counterfactual one, the other non implicative reading associated with imperfective, to which we now turn to.

Imperfective on a root modal doesn't always yield an ability reading as in ((100)a). In these cases, the use of the imperfective feels counterfactual²⁶. Consider the following example:

- (103) Jane pouvait prendre le train pour aller à Londres, ?(mais elle...)
Jane could-impf take the train to go to London, ?(but she...)

In a sentence like (103) we really want to have a continuation which states that, in fact, Jane took some other means of transportation or that she decided not to go. (103) is compatible with Jane actually taking the train and going to London, but the preferred reading is that she in fact didn't. One crucial difference between ((100)a) and (103) is the type of event that they modify: while talking to monkeys can easily be seen as an ability, taking the train isn't. It lends itself more easily to a particular occasion where the circumstances matter more than Jane's own skills. We can coerce the complement in (103) to be more like a long term ability, in which case, it loses its counterfactuality. Imagine that Jane lives in a far away place and that taking the train to London takes weeks, under horrific and dangerous traveling conditions, etc.. We then obtain a reading more similar to that of ((100)a). We also feel that this 'ability' to take the train must have been instantiated at some point before, for the speaker to make this claim.

Importantly, informants do not find a meaning difference between the minimal pair below which contrasts imperfective and *conditionnel* (a morpheme used specifically to express counterfactuality in French), when the continuation denies that the complement took place.

²⁶ Thanks to Gennaro Chierchia, and Irene Heim p.c. for pointing this out.

- (104) a. Jane pouvait prendre le train, mais elle a décidé de prendre l'avion.
Jane could-impf take the train, but she decided to take the plane.
- b. Jane aurait pu prendre le train, mais elle a décidé de prendre l'avion.
Jane could-cond take the train, but she decided to take the plane.

In the next section, we will go over the various uses of imperfective morphology. We will see that they encompass genericity and counterfactuality, among others.

2. DIFFERENT USES OF THE IMPERFECTIVE (*IMPARFAIT*)

2.1. CHARACTERISTICS OF THE IMPERFECTIVE

Focusing on Romance²⁷, imperfective aspect (*imparfait*) appears in various environments, and the range of meanings it has makes it difficult to give it a unified analysis. However, several characteristics recur across the different interpretations of the imperfective, which we will now briefly review. First, in Romance at least, the perfective/imperfective distinction only appears in the past. Thus the *imparfait* is usually associated with past tense.

The second characteristic of sentences with imperfective is the 'on-goingness' of the event they describe. In simple cases, it seems that the crucial difference between perfective and imperfective is the durational properties of the event they operate on:

- (105) a. Lydia lisait un livre cette après-midi.
Lydia read-impf a book this afternoon
'Lydia was reading a book this afternoon.'
- b. Lydia a lu un livre cette après-midi.
Lydia read-pfv a book this afternoon
'Lydia read a book this afternoon.'

²⁷ The cross-linguistic picture is that languages either lump together habitual, progressive and counterfactual meanings under the imperfective (Romance); they can also have three separate morphemes. However, if a grouping between two of these uses is made, it is usually between the habitual/generic and the counterfactual meanings, with the progressive as a separate morpheme, as in Hindi, for instance (Iatridou 2000). Some languages, like Bulgarian and Greek have a perfective/imperfective distinction in the future as well. I leave it up to future research how to extend my proposal to these types of languages. My claims will thus be about the *imparfait* in French and its equivalent in Italian and Spanish. I will end up with three separate operators (progressive, generic, and counterfactual), which do not straightforwardly explain why, typologically, generics and counterfactuals should form a unit separate from progressives. I do, however, give an explanation for why the three operators use the same morpheme (as, e.g., in French). I would have to venture that there is something extra about the progressive which warrants a separate morphological spell-out, in those languages that do.

The major meaning difference between the pair of examples above is that the entire book was read *this afternoon* in the case of the perfective ((a)), but not necessarily so for the imperfective ((b)). Thus Klein (1994) proposes that the difference between perfective and imperfective is that, with the former, the event time is contained within the reference time, whereas with the latter the reference time is contained within the event time. This difference is represented for example in Kratzer (1998)'s lexical entries for the two aspects, which differ only in the ordering of the reference time and the event time:

- (106) a. [[PERFECTIVE]] = $\lambda P. \lambda t. \lambda w. \exists e[\tau(e) \subseteq t \ \& \ P(e)(w) = 1]$
 b. [[IMPERFECTIVE]] = $\lambda P. \lambda t. \lambda w. \exists e[t \subseteq \tau(e) \ \& \ P(e)(w) = 1]$

The third characteristic of the imperfective is that, contra perfective sentences, those with imperfective often seem to involve some modality. We will see shortly, however, that the same modal component is not used across all (modal) uses of the imperfective.

A fourth feature of the imperfective, is that it is odd out of the blue, and requires either a time adverb, a when clause, or a conversational background which provides some salient time interval (Delfitto and Bertinetto 1995, Bonomi 1995, a. o.). This fact has led some researchers to claim that the imperfective is anaphoric in nature:

- (107) a. ?? Jane dormait.
 Jane slept-impf
 b. A cinq heures, Jane dormait.
 At 5 o'clock, Jane slept-impf
 c. Quand Darcy est entré, Jane dormait.
 When Darcy came in, Jane slept-impf
 d. A chaque fois que Bingley arrivait, Jane dormait.
 Every time Bingley came in, Jane slept-impf
 e. A: Que faisait Jane à 5 heures ? B: Elle dormait.
 What was Jane doing at 5 ? She slept-impf

Given these characteristics, we will see in the next two sections that one can differentiate two main classes of uses of the imperfective. The first one is what I will call the durative class. It includes the progressive, the habitual, and the generic, which all share the properties of on-goingness, pastness and weird-out-of-the-blue-ness of the imperfective. They describe an event,

a habit, a pattern which is on going at some past time. I call the second the counterfactual class. Members of this class lack both of these features: they do not have to be set in the past, they can refer to completed events, and they are not odd out of the blue. Both classes involve some modality. However, it is not clear that the modality in both classes can be reduced to one. We now turn to each of these classes.

2.2. DURATIVE USES

The *imparfait* (imperfective) in a run-of-the-mill sentence can either be interpreted as a progressive (as in (108)a), or a habitual (as in ((108)b)). Both interpretations refer to a time prior to the utterance time. The two readings are disambiguated by the context, or through overt adverbials:

- (108) a. Quand Jane est arrivée, Bingley **fumait**.
When Jane arrived-pfv, Bingley smoked-**impf**
'When Jane came in, Bingley was smoking'
- b. A l'époque, Bingley **fumait**.
Back in the days, Bingley smoked-**impf**
'Back in the days, Bingley smoked (habitually)'

The *imparfait* can also express genericity. The sentence below describes a generalization, which held at some past time:

- (109) A l'époque, les femmes portaient des corsets.
Back in the days, women wore-**impf** corsets

All three uses of the 'durative' class involve some modal component. For instance, the progressive has to incorporate a modal element in order to handle cases of the so-called Imperfective Paradox (Dowty 1972), illustrated below:

- (110) Lydia was embroidering a circle when she got distracted by a navy officer.

The sentence in (110) is true, even if Lydia never finished the circle. If this is so, though, how do we know that we are dealing with a circle-embroidering event? The semantics of the imperfective in (72)b) are too simplistic to be able to handle the lack of entailment that Lydia will have embroidered_a_circle. Since Dowty (1972), many subscribe to the view that while

there is no complete embroidering a circle event *in the actual world*, such an event exist in some distant worlds, namely, in all of the worlds where the event is not interrupted (cf. Landman 1992, Portner 1998, a.o.)²⁸.

Similarly, habituais describe habits that are supposed to go on in time, unless some outside factor intervenes (Ferreira 2004, 2005). (111) will still be judged true if Darcy breaks a leg and never plays soccer after the utterance time:

(111) Darcy plays soccer on Thursdays.

For both the progressive and the habitual, the modal quantification seems to be universal: in all worlds where things go uninterrupted, the event culminates/the habit goes on.

Generics resemble habituais in many ways: they use the same morphology (simple present in English for instance); they both describe generalizations which tolerate exceptions (e.g., the sentence in (111) is still true if, on some rainy Thursday, Darcy didn't play soccer). In fact, many actually assimilate one with the other. However, there are differences (subtle, perhaps), which seem to set them apart. The first difference is that generics, *contra* habituais, do not even require verifying instances. Consider the following pair of sentences, which have been argued to involve genericity. ((112)b) is an example of a kind-referring generic, which here involves a bare NP, ((112)a) is a case of a characterizing sentence generic (cf. Krifka et al., 1995)):

- (112) a. This machine crushes oranges.
b. Navy officers dress handsomely.

As Krifka *et al.* argue, the example in (112)a) doesn't require verifying instances: it will still be judged true if the machine has never been used before. The habitual in (111), on the other hand, is judged false if Darcy never played soccer in his life. A second difference is that in the case of generics, there seems to be a deeply rooted connection between the subject and the main predicate, which warrants a modal characterization. The sentence in (112)b) asserts that (most) navy officers dress handsomely, but it also indicates that this generalization is not accidental:

²⁸ For an alternative, non modal proposal, which takes incomplete events as primitives, see e.g., Parsons (1990), Vlach (1981), ter Meulen (1985), Bach (1986).

navy officers dress handsomely *in virtue* of being navy officers (Cf. Greenberg 2002, Carlson 1988). This non accidental link between the subject and the main predicate doesn't need to be present in the case of the habitual in (111): Darcy could be playing soccer on a regular basis, but this could be accidental: Darcy has no intrinsic property in virtue of which he plays soccer. Contrast (111) with *German men play soccer*.²⁹ The bare plural helps a generic interpretation: we get a sense that the soccer playing is in virtue of being German (soccer is in their blood). (111) can also get such a reading, and, in that case, could be argued to involve genericity rather than habituality. Whether or not these differences warrant different analyses for habituals and generics, we see that both clearly involve a modal component (see for instance Krifka *et al.*, 1995 for a modal account of a generic operator).

2.3. COUNTERFACTUAL USES

The various uses illustrated below share the characteristics that imperfective lacks its on-going character, and its pastness, and involves situations remote from the actual world.

2.3.1. Counterfactual conditionals

The imperfective is the aspect that is used in *counterfactual conditionals*, as is illustrated below. The hallmark of counterfactual (or subjunctive) conditionals is the implication that their antecedent doesn't hold in the actual world, in contrast to indicative conditionals. In (113)a) the speaker implicates that Jane *is* here, and in (113)b) that she is *not* coming tomorrow:

- (113) a. Si Jane n'**était** pas là (maintenant), Bingley **fumerait**.
 If Jane was-**impf** not there (now), Bingley smoke-**cond**
 b. Si Jane venait demain, Bingley **arrêterait** de fumer.
 If Jane came-**impf** tomorrow, Bingley stop-**cond** smoking.

Note that if we replace the imperfective with perfective morphology, the conditional turns into a straightforward indicative conditional. The counterfactuality disappears, that is, the speaker is agnostic about the truth of the antecedent (whether Jane came or not):

- (114) Si Jane est venue, Bingley n'a pas fumé/n'aura pas fumé.
 If Jane came-**pfv**, Bingley did not smoke-**pfv**/will not have smoked
 'If Jane came, Bingley didn't smoke'.

²⁹ Example courtesy of K. von Fintel.

Morphologically, in French, in a counterfactual conditional such as those in (113), the antecedent shows imperfective aspect, while the consequent shows *conditionnel* morphology, which looks like the agglutination of future tense and imperfective aspect (cf. Iatridou 2000)³⁰. We will look at the role the future plays in the next section.

Despite the fact that imperfective morphology is usually associated with past tense (as was the case for the durative class), the sentence in (113) is supposed to be about the utterance time, as evidenced by the adverbial *now*. Furthermore, the imperfective in counterfactuals seems to lose its on-going character. In the following sentence, a speaker indicates that if a certain *completed* event happened, another (complete one) would too:

- (115) Si Lydia lisait un livre, sa mère lui donnerait une pomme.
If Lydia read-imp a book, her mother would give her an apple

On its most natural reading, the sentence above means that Lydia's mother would give her an apple if she read a book in its entirety, not for merely being in the process of reading it.

2.3.2. Imperfect conditionals

The imperfective by itself (i.e., without *conditionnel* morphology) can also have a counterfactual meaning in Italian (Ippolito 2004):

- (116) Se Bingley arrivava ieri sera, incontrava Jane.
If Bingley arrive-imp yesterday night, he meet-imp Jane
'If Bingley had arrived last night, he would have met Jane'.

Both the antecedent and the consequent have imperfective morphology. Following Ippolito's terminology, we will refer to this type of conditional as Imperfect Conditional (IC). As Ippolito (2004) shows, in uttering (116), the speaker presupposes that the antecedent is false, and in contrast to subjunctive conditionals (those that use *conditionnel* morphology in their consequent, and, in Italian, subjunctive mood in their antecedent), the falsity of the antecedent is not cancelable. While the exact equivalent of (116) is odd in French, the same effect obtains with

³⁰ Italian further requires subjunctive morphology in the antecedent.

either: (i) two imperfects, but a conjunction³¹ instead of an if-clause; or (ii) an if-clause with pluperfect in the antecedent and imperfect in the consequent:

- (117) {Il arrivait/S'il était arrivé} hier soir, (et) il voyait Jane.
He arrive-impf/If he had arrived last night, (and) he saw-imp Jane
'Had he arrived last night, he would have seen Jane.'

2.3.3. Other modal uses³²

The imperfective has additional 'modal' uses, where, again, the sentences are not interpreted in the past, nor require incompleteness of the event they describe. The following examples illustrate a few of these uses (from Ippolito 2004):

- (118) a. Volevo del pane, grazie. [impf of politeness]
I wanted-imp some bread, thank you
b. Gichiamo ad un gioco nuovo! Io ero l'albero, tu il cavallo. [impf of play]
Let's play a new game! I was-impf the tree, you the horse
c. Domani andavo in biblioteca [impf of planning]
Tomorrow I went-imp to the library

In (a), the desire/request is at the time of utterance; the politeness effect seems to result from the speaker not making a direct request. In (b), the speaker is playing a game *now*, but the imperfective seems to place her and her addressee in a possible world where she is a tree and her addressee, a horse.

In (c) the going-to-the-library event is set in the future, while the 'plan' was made in the past. This imperfect of planning arises when the event described is plannable (cf. Copley 2002 and references therein), and, surprisingly allows future adverbials, without the support of a future tense. In Italian, (c) is perfectly grammatical on its own and doesn't need to be embedded overtly. In French, however, (c) is odd. Note that the presence of a future time adverbial is still possible with imperfective, when a sentence like (c) is embedded. French is an obligatory sequence of tense language: thus it requires some past tense morphology in an embedded

³¹ This conjunction has a causal meaning: p and q means p causes q (cf. von Stechow and Iatridou 2005).

³² An in-depth analysis of the various modal uses of the imperfect is beyond the scope of this thesis. I refer the interested reader to Ippolito (2004) and Giorgi and Pianesi (2004), and references therein.

complement under a past tense: In the presence of a future adverbial, in the examples below, only imperfective is possible (a), while perfective is completely out (b)³³:

- (119) a. Jane a dit que Darcy allait à la bibliothèque demain.
Jane said-pfv that Darcy went-**impf** to the library tomorrow
- b. *Jane a dit que Darcy est allé à la bibliothèque demain.
Jane said-pfv that Darcy went-**pfv** to the library tomorrow

We see then that we have a wide range of interpretations associated with imperfective morphology, with some common characteristic traits, namely the on-goingness/incompleteness of the event, shared by the progressive, habituais, and generics, and some modality, albeit of various natures. There thus might be hope for a unified semantics of the imperfective. Some existing proposals give a unified treatment of the habitual and the progressive (Bonomi 1995, Cipria and Roberts 2000, Ferreira 2004, 2005). These proposals are rather convincing, and it may very well be that there is a single aspectual or modal operator responsible for progressive and habitual readings. However, one will be hard pressed to extend such accounts to the other uses of the imperfective. As we saw, the ongoingness component is not enforced in counterfactuals uses. Furthermore, while the progressive and habituais do involve modality, they still have some extensional component: there is some event going on in the actual world, even if it is just a subevent (or a *stage* of an event in Landman's terminology). No part of the event described in a *counterfactual* holds in the actual world³⁴. Because the imperfective (and, in fact, the present tense as well) doesn't always enforce an-ongoing meaning, Giorgi and Pianesi (2004) argue that the imperfective and the present are aspectually neutral.

A unified semantics of the imperfective may not be completely hopeless, but is proving to be very difficult to achieve. This suggests that a more hopeful route would be to explain the distribution of the imperfective as some kind of default. Such a move has been advocated, for instance, for the present tense by Sauerland (2002), or for the subjunctive, by Farkas (1992), and Schlenker (2005), a. o., where their distribution is explained by assuming that it is a semantic

³³ Note, in passing, that present tense also allows future adverbials with planable events. We will return to the present tense in the appendix:

(i) Darcy va à la bibliothèque demain.
Darcy goes to the library tomorrow.

³⁴ Although one may argue that "the plan" is part of the actual world with the imperfect of planning (cf. Copley 2002).

default. In the next section, I will suggest a way to make sense of the distribution of the imperfective. I will not treat the imperfective as a semantic default *per se*, but as a morpheme which doesn't have any semantic content: Imperfective morphology will be the spell-out of the past tense under certain conditions, which I will make explicit in the next section.

3. PROPOSAL FOR THE IMPERFECTIVE

Summing up the results of the previous section, we saw that imperfective morphology appears in a wide range of constructions. We discerned two broad classes of uses: the durative class, which I further subdivided into progressive/habitual interpretations on the one hand, and generic ones on the other; and the counterfactual class. I first put aside the morphological output to look at the semantic components necessary to account for the meanings involved in the constructions discussed above. I then propose a way to explain the morphology.

3.1. DIFFERENT ASPECTUAL OPERATORS

I will assume that there is a real split between the counterfactual modals and the progressive/habituals, as they do not appear in complementary distribution. It is in fact possible to have a progressive, a habitual, or a generic inside a counterfactual. The example in (a) involves the imperfect of play: the smoking is most readily interpreted as a habit or maybe an event in progress; the one in (b) involves a counterfactual, and the taking the train is interpreted as ongoing in the relevant worlds at 6:00pm:

- (120) a. (On dirait que) j'étais le papa et je fumais.
(Let's say) I was-imp the daddy and I smoked-imp
- b. Si Jane prenait le train à 18 heures, elle n'aurait pas pu commettre le crime.
If J. took-impf the train at 6:00pm, she could not have committed the crime.

3.1.1. HAB/PROG

We will first turn to the progressive and habitual operators³⁵. Building on Dowty (1979) and Landman (1992), Portner (1998) proposes a modal treatment of the progressive, which involves universal quantification over a set of ideal worlds. The set of accessible worlds are those in which certain circumstances of the base world hold (i.e., the modal base is circumstantial), and these worlds are further ordered by an ordering source which consists of a set of propositions describing various obstacles, such that the best worlds will be those where no obstacle gets in the way, and the worst worlds will have a series of obstacles. Let's consider a concrete example:

(121) Jane was climbing the mountain, when she was eaten by a bear.

The accessible worlds will be those in which the circumstances of the base world relevant for the completion of the event hold: Jane's physical condition, her intent to go up the top, the temperature, the weather, etc... These worlds are ordered with respect to how few interruptions occur: Jane doesn't get eaten by a bear, no sudden storm occurs, Jane doesn't twist her ankle, etc... In the best accessible worlds, there is no such interruptions and Jane finishes climbing the mountain. However, if, in the actual world, a bear enters the picture and eats her, the actual world won't be among the best worlds, and the sentence will be true, even if, in actuality, Jane did not complete the event. More formally, Portner proposes the following: PROG takes an event e and a predicate of events P , and yields a true sentence if all of the best worlds have a larger event e' (which includes e as a subpart) with property P . The best worlds are given in (b): they consist of the least interrupted worlds among those circumstantially accessible:

- (122) a. $\text{PROG}(e,P)$ is true at w iff $\forall w' \in \text{Best}(\text{Circ}, \text{NI}, e, P): \exists e'$ which includes e as a nonfinal subpart s.t. $P(w')(e')$ is true
 {Circ: circumstantial modal base, NI: no interruption ordering source}
- b. $\text{Best}(\text{Circ}, \text{NI}, e, P) = \lambda w'. w' \in \cap \text{Circ}(e, P)$ s.t. $\neg \exists w'' \in \cap \text{Circ}(e, P) : w'' <_{\text{NI}, e} w'$.

Note the resemblance with our actuality entailment cases, which involve an (actual) event whose description is in the scope of a modal. Here we have an actual event which in some worlds *grows*

³⁵ I restrict the discussion to Portner (1998) and Ferreira (2004)'s proposals for reasons of space, as a way to illustrate that a unified account of the progressive and the habitual is attainable. Other such proposals include Bonomi (1995) and Cipria and Roberts (2000).

into a P-event. What prevents an ‘actuality entailment’ that the completed event took place in the actual world is the subpart relation inside the scope of the modal: only *part* of that event is asserted to take place in the actual world, whereas we get a complete event with perfective.

Ferreira (2004, 2005) extends Portner’s analysis to simple habituals. He shows that both the progressive and habituals involve the same modality: just as a progressive describes an event in progress which will continue (and culminate) if it isn’t interrupted, a habitual describes a habit (e.g., playing soccer), which, if it isn’t interrupted (e.g., by breaking one’s leg), will continue. Ferreira thus claims that the same operator (IMP) is involved. The crucial difference between a progressive and an habitual, he argues, is in the number marking of the event: a progressive reading selects a set of singular events (e.g., $\{e_1, e_2, e_3\}$), a habitual reading a set of plural events (e.g., $\{e_1 \oplus e_2, e_1 \oplus e_3, e_2 \oplus e_3, e_1 \oplus e_2 \oplus e_3\}$). Thus the habitual sentence in (a) get the truth conditions in (b):

- (123) a. [_{TP} Darcy plays soccer]
 b. $[[\text{TP}]]^w = 1$ iff for every world w' in $\text{Best}(\text{Circ}, \text{NI}, e, P)$ there is a plural event e that occurs in w' , such that $\text{Pres} \supseteq \tau(e) \ \& \ \text{play_soccer}(e, d)$.

At this point, I will take this definition of the progressive/habitual as is, and only modify it slightly so that it provides its own event closure, in order to be on *a par* with Perfective Aspect. From this point on, I will refer to perfective aspect as Perf^{36} , and the progressive/habitual as PROG:

$$(124) \text{PROG}(t, w) = \lambda P_{\langle s, et \rangle} \exists e[e \text{ in } w \ \& \ \tau(e) \subseteq t \ \& \ \forall w' \in \text{Best}(\text{Circ}, \text{NI}, e, P): \exists e'[e \subseteq e' \ \& \ e' \text{ in } w' \ \& \ P(e', w')]$$

In a matrix context, we will thus get an actual event, which is a subpart of a larger event e' , which in all best non interrupted worlds, is P-event.³⁷

³⁶ Perf stands for perfective aspect, not to be confused with the Perfect operator, a (modal) operator which introduces a time interval, and in most cases gets spelled out as perfective in French and Italian. For reasons of space, I won’t include the Perfect in our discussion. See e.g., Iatridou *et al.* 2001, and references therein.

³⁷ This definition is quite complex, and one can see that there are in fact two event quantifications at work. It would be nice to be able to break down this definition into smaller parts, if, for instance, one of these existential quantifiers over events could be our perfective aspect (Perf). But we run into problems with either one. If we say that the topmost one is really Perf, then it would have to originate in the embedded VP, and bind its trace e . But that’s not what we want: we want the completed event (e') to be a P-event not the subpart one. Furthermore, even if we avoid this problem by assuming that Perf is base-generated there, then we lose the Aspect as quantifier story, plus, we lose the spell-out condition: Perf will be adjacent to Tense, and should be spelled out as perfective. The problem

3.1.2. GEN

As we saw in section 2.1, while generics resemble habituals in many ways, their modality seems to set them apart: generics do not require verifying instances and establish a non accidental connection between the subject and the main predicate. I take this difference to be fundamental enough, as to group habituals and progressive together in opposition to generics, rather than having generics and habituals together in opposition to progressives.³⁸

With habituals and progressives, there is something on-going in the actual world: a stage of an event or a series of events. With generics, however, we express a disposition which may never have been instantiated. So what holds in the actual world is some disposition surrounding the reference time, but not a specific event, as in the case of the progressive and habituals. Contrast the following pair (repeated from section 2.2):

- (125) a. This machine crushes oranges. [from Krifka et al. (1995)]
 b. Darcy smokes.

We can imagine a scenario where the machine has never been used, but was designed to crush oranges, and readily accept (a) as true. It is, however, much harder to accept (b) if Darcy has never smoked in his life. For Ferreira (2004), the reason why we assume that Darcy has smoked before is because this fact is a relevant circumstance, which is part of the modal base.

Note that the same sentence can be ambiguous between a generic/dispositional reading and a habitual one. As pointed out by Lawler (1973) and Dahl (1975), the following type

with claiming that the lower existential quantifier over event is Perf is that we would need the temporal restriction $\tau(e') \subseteq t$ to hold in all inertia worlds, which is problematic. We could add to the progressive's definition the introduction of a time that would bind the time variable, but this is a bit *ad hoc*. (I. Heim, p.c.).

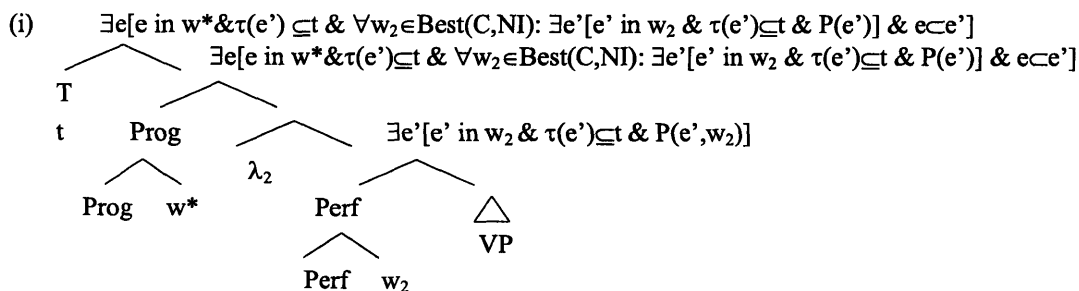

³⁸ Note that grouping habituals with progressives rather than with generics is, at this point at least, a matter of personal preference, and doesn't affect the proposal. What matters is that, in either case, we have at least two separate operators: PROG and GEN.

of sentence is ambiguous between a habitual reading (beer is Darcy's drink of choice and drinks it frequently) and a dispositional reading (Darcy doesn't object to beer drinking):

(126) Darcy drinks beer.

Generics express non accidental generalizations: it is no accident that the machine in (125)a crushes oranges: it does so because it was build in a certain way. These generalizations can be about situations, or they can be about individuals. Consider the following example:

(127) A lion has a bushy tail.

Under its most natural reading, the sentence in (127) makes a claim about all normal lions, namely that they have a bushy tail. The claim is about all normal lions, not a specific one. I will thus assume that GEN is an unselective binder, which binds all free occurrences of individual or event variables. In the above example, GEN binds an individual variable x in the manner sketched below (cf. Heim 1982, Krifka et al, 1995)³⁹:

(128) GEN[x,w](x is a normal lion in w; x has a bushy tail in w)

We see then that free occurrences of individual variables get bound by GEN. What about free event variables? I have assumed so far that predicates take as their event argument a quantifier over events (either Perf or PROG). In order to account for generic statements, I will assume that GEN is an unselective binder, which can bind free event variables in its scope, the way it binds free individual variables. Thus, the grammar makes available the following options:

- (129) a. Perf₁ V(e₁)
b. PROG₁ V(e₁)
c. GEN₁ V(e₁)

The semantics of GEN will be as followed (adapted from von Stechow, 1997, as to include times, and events):

³⁹ I leave aside a precise analysis of bare plurals and indefinites, and the complications that arise once GEN quantifies over both eventuality variables and individual variables, and in particular with i-level predicates.

- (130) For σ either e or ϵ , for all $p, q \in D_{\langle \sigma, t \rangle}$, $f \in D_{\langle s, \langle \sigma, t \rangle \rangle}$:
 $\llbracket \text{GEN} \rrbracket (f)(p)(q)$ is true in w at t iff $\forall x \in f(w, t): p(x) \rightarrow q(x)$
 where $f(w, t) = \lambda x. x$ is normal/ideal from the perspective of w at t .

GEN quantifies over either individuals or events. p is a restriction, which is given by context, or by the presuppositions of the proposition GEN modifies (cf. Schubert and Pelletier 1986). f is a selection function, which restricts the set of events or individuals to the *normal/ideal* ones, from the perspective of w at t . This selection function does the modal work, and will vary contextually: we may be talking about ideal individuals/events, where *ideal* is in terms of what nature intended (e.g., ideal lions) or what the engineer intended (e.g., ideal uses of the machine)⁴⁰. The set of events/individuals quantified over will only be the normal/ideal ones, where normalcy/ideality is anchored in a world and time. The world and time variables of the selection function f will be bound by Tense and the matrix binder respectively. The following example illustrates:

- (131) $\text{GEN}(f)(p)(\llbracket \text{this machine crush oranges} \rrbracket) = 1$ iff
 $\forall e [e \in f(w^*, t^*): p(e) \rightarrow \text{crush-oranges}(e) \ \& \ \text{Ag}(e, \text{this machine})]$
'All normal/ideal events e from the perspective of w^ at t^* , s. t. some relevant preconditions for e hold (e is a use of the machine, there are oranges, the machine is working...) are crushing-oranges events.'*

To sum up, the crucial difference between PROG and GEN is that the latter can bind free event variables. Note that this proposal is at odd with a trend in the literature to group GEN and HAB together, given their closeness in meaning. This closeness in meaning comes from the fact that both deal with several events and not just one. Note however that in the DP domain, *every NP* and *the NPs* also deal with several individuals, but that despite that the plural definite will end up with a closer semantics to a singular *the NP*, than to *every NP* (for a treatment of habituais as plural definites, see Ferreira 2005).

⁴⁰ Of course, the engineer might not have intended the machine to crush oranges; it might be a coffee maker. However, a sentence such as 'this coffee maker crushes oranges' begs for verifying instances, and we might be lapsing back into a habitual reading.

3.1.3. Counterfactuality

What sort of modality is involved in counterfactuals? What role do the various morphological elements involved play? As originally pointed out by Iatridou (2000), the following morphemes recur cross-linguistically in counterfactuals. The first is subjunctive mood, which I will put it aside, as it is not used in French counterfactuals anymore. The second element is past morphology, which doesn't seem to be interpreted semantically as a past tense. The remaining two elements are a future, and imperfective aspect: In French, counterfactuality usually requires *conditionnel* morphology, which looks like a combination of the future (-r) and imperfective morphology (-ait) (Note in passing that the English translation requires the future auxiliary *would* in the past.):

- (132) Si Jane écrivait à Bingley, il répond.r.ait.
If Jane wrote-imp to Bingley, he answer-FUT-IMP
'If Jane wrote to Bingley, he would write back'.

In this section, I first propose that we have a counterfactual modal as a primitive. I then go over the various morphological elements involved, and see what role they play, semantically, if any.

3.1.3.1. A counterfactual modal

I would like to propose that we treat counterfactuality as a primitive, that is, as a full modal element in its own right (henceforth CF). In most cases, in French, this element will be expressed through *conditionnel* morphology, which I take to be decomposable as a kind of future modal in the scope of a past. In English, this counterfactual modal will be expressed by *would*, which also seems to involve past and a future modal. This claim has the consequence that when a modal auxiliary is present, it will not carry the counterfactuality; instead, it will either be a root, or an epistemic modal, scoping below or above the counterfactual element. But this is not uncontroversial⁴¹. Condoravdi (2001), for instance, argues that non root modals in English (like *might*) can get an epistemic interpretation (helped out by the adverbial *already*), or a

⁴¹ A similar issue arises with conditionals. When no modal is present overtly, it is generally assumed that we have a covert universal modal. When a modal is there, it is assumed then that this modal is the only modal (no additional covert modal) (see for instance von Stechow 1997). However, given the universality of this covert modal, and depending on the sorts of worlds it quantifies over, this covert modal might always be there, but its presence goes undetected. The case might be stronger for counterfactuals since we actually have an overt morpheme (e.g., the *conditionnel* in French).

counterfactual/metaphysical one (helped out by the adverbial *still*), depending on whether they scope above or below a perfect. Consider her examples:

- (133) a. They might (already) have won the game.
b. They might (still) have won the game.

In (a), we are dealing with an epistemic possibility about a past time: it is possible, as far as I (the speaker) know (right now), that (at some past time) they won the game. In (b), we are talking about a possibility at a past time, of an outcome future to that past time: at that time, there was a possibility that they would win the game (but we infer that they in fact didn't win). This is, in Condoravdi's terminology, the metaphysical/counterfactual reading. Thus, crucially, for Condoravdi, *might* can have a metaphysical modal base, responsible for the counterfactuality.

Given my assumption for a primitive CF, I take these examples, *contra* Condoravdi, to not simply involve one modal element (here the modal *might* with a metaphysical accessibility relation), but two: an epistemic *might* on top of a CF. This is, in fact, what Stalnaker (1981) proposes, for cases like these, based on theoretical reasons. In his account, a counterfactual conditional involves an operator $>$, such that the counterfactual ' $\alpha > \beta$ is true in w iff β is true in *the world most similar to the evaluation world in which the antecedent α holds*'. Importantly then, it doesn't make sense to talk about a universal or an existential counterfactual modal. Thus in cases involving *might have* with a counterfactual reading, *might* cannot be responsible for the counterfactuality. Instead, Stalnaker takes *might have* to involve an epistemic *might* on top of a counterfactual operator. Even if we do not adopt Stalnaker's proposal for counterfactuals, there are still reasons to believe that (133) does not involve a single modal when expressing a counterfactual claim.

The first reason has to do with the morphology involved. While in English *might+CF* would be expressed as *might have* (presumably because the sequence *might would* is morphologically blocked), in French, where CF is expressed by a morphological affix (*conditionnel*, or optionally *imparfait*), the counterfactual reading in (133)b) *requires* one of these affixes on the modal:

- (134) a. Il aurait (encore) pu gagner.
He has-cond (still) could win

- b. Il pouvait (encore) gagner.
He could-imp (still) win.

The epistemic reading, on the other hand, is morphologically simpler. We can either have a present tense modal, followed by an infinitival with an auxiliary (135)a); or we can have perfective morphology directly on the modal (135)b)⁴²:

- (135) a. Il peut (déjà) avoir gagné.
He can (already) have won
- b. Il a (déjà) pu gagner.
He has already could win.

Thus, while in English the morphology supports a single modal account, French morphology seems to indicate that something extra is involved in the counterfactual reading.

The second piece of evidence in favor of a separate CF modal involves comparisons between sentences with and without an overt modal auxiliary. We know that counterfactuality doesn't need an overt modal (see (a) below, for instance). Take the following triplet of counterfactuals, which differ in the (a) has no overt modal, (b) has an existential modal and (c) a universal:

- (136) a. Si Darcy ne s'était pas tordu la cheville, ils auraient gagné.
If Darcy had-imp not twisted his ankle, they have-COND won
'If Darcy hadn't twisted his ankle, they would have won'
- b. Si Darcy ne s'était pas tordu la cheville, ils auraient pu gagner.
they have-COND could win
'If Darcy hadn't twisted his ankle, they could have won'
- c. Si Darcy ne s'était pas tordu la cheville, ils auraient dû gagner.
they have-COND must win
'If Darcy hadn't twisted his ankle, they should have won'

Interestingly, there is some meaning difference between (c) and (a): in (a) the winning seems to be more certain than in (c). Why should that be? According to the CF as a primitive account, these meaning differences fall out naturally. The overt modal auxiliary doesn't carry the counterfactuality. Instead it is an epistemic modal, on top of CF:

⁴² Note that with 'already', the epistemic reading of (135)b) is dispreferred in favor of an ability reading.

- (137) a. It could_{epis} be that if... they would_{CF} have won
 b. It must_{epis} be that if... they would_{CF} have won

And, indeed, (b) could be paraphrased as follows:

- (138) Il se peut que si Darcy ne s'était pas tordu la cheville, ils auraient gagné
 It can_{epis} be that if Darcy hadn't twisted his ankle, they would have won.

The reason why the winning seems more certain without the overt epistemic modal is reducible to the reason why '*It must be raining*' is less certain than '*it is raining*'.

Opponents of the primitive CF account would say that the modal auxiliary in (c) carries the counterfactuality, and that (a) is a case of a covert modal with a counterfactual sense. The resulting meanings would be different because the covert modal is not the same as the overt one. Now, it seems to me that the primitive CF is the simpler theory: we need a meaning for an (epistemic) modal (to handle cases such as (133)a)) and a meaning for CF (to handle cases like (136)a)), and we can compose a meaning for (136)c) based on the two we already have. In the other type of account, we need a meaning for an (epistemic) modal (to handle cases such as (133)a), but we now need two different meanings to handle cases like (136)c) AND cases like (136)a).

Furthermore, the meanings of the following sentences seem to involve a counterfactual modal on top of a *root* modal. This is highlighted in the English translation of ((139)b). In French, however, we only have one modal auxiliary plus *conditionnel* morphology:

- (139) a. Si Darcy n'était pas venu la chercher, Jane aurait pu prendre le train.
 If Darcy hadn't come pick her up, Jane could-cond have taken the train.
 '*If Darcy hadn't picked her up, Jane could have taken the train*'.
 b. Si Darcy n'était pas venu la chercher, Jane aurait dû prendre le train.
 If Darcy hadn't come pick her up, Jane must-past-cond take the train.
 '*If Darcy hadn't picked her up, Jane would have had taken the train*'.

Again, this is straightforwardly captured if CF is its own modal, and the overt modal auxiliary has a root interpretation (e.g., goal-oriented). Opponents of the CF as a primitive account, on the other hand, will have to come up with yet another special meaning for the CF+root meaning combination. However, it is not clear what would then justify the meaning in (139)b) to be different from that in (136)c).

3.1.3.2. Past

As we noted before, a counterfactual like the one above does not refer to a past event, but in the absence of time adverbials, refers to the utterance time. To put this conditional in the past, we need pluperfect morphology:

- (140) Si Jane avait écrit à Bingley, il **au.r.ait** répondu.
If Jane had-imp written to Bingley, he have-FUT-imp answered
'If Jane had written to Bingley, he would have answered'.

The morphological breakdown of the pluperfect involves an auxiliary plus participle (as with perfective), with imperfective morphology on the auxiliary.

The presence of past morphology, which seems to have nothing to do with pastness, is puzzling. For our purposes, I will take for granted that we do have a past tense in counterfactuals (even with the present-oriented ones), but, following Iatridou (2000), I will assume that this past is 'fake', that is, it does not refer to an interval prior to the utterance time. Iatridou (2000) proposes that the 'past' morpheme is a feature which is interpreted either temporally or modally, and whose role is to relate two times or two worlds: a topic time/world and the world/time of the speaker. The exclusive feature (morphologically realized as past) states that the topic t/w excludes the utterance time (in 'real' past uses) or the actual world (in 'counterfactual' uses). Another possibility, offered by Arregui (2005) to account for this 'past' tense is that counterfactuals are *de re* claims about a past interval. In this account, the past in the antecedent and the consequent are also 'fake' in that they are bound tenses (cf. Kratzer 1998), which get spelled out as past via some morphological agreement with the higher (real) past, the one the *de re* claim is about. For other proposals for the presence of past tense, see e.g., Ippolito (2002), Han (1996) and Ogihara (2000). Importantly, we have a past tense morphologically, but not semantically.

For the other counterfactual uses of the imperfective, I will assume that a 'fake' past, or a sequence of tense past is also at work. Giorgi and Pianesi (2004) suggest, for instance, that cases of the imperfective of planning are embedded under a covert modal 'expect', which can be set in the past. In that case, the past imperfective morphology is simply morphological agreement, and is semantically vacuous:

- (141) [I expected that] Domani andavo in biblioteca.
 [I expected-past that] Tomorrow I went-Ø-imp to the library
 'I expected that I was going to the library tomorrow'.

3.1.3.3. Future and modality

Many accounts of counterfactuals take the future morphology to reflect some semantic future. Mondadori (1978) takes counterfactuality to involve a 'future possibility in the past'. Condoravdi (2001) proposes that the modality involved is 'metaphysical' that is, it has to do with 'how the world may turn out, or might have turned out, to be' (p3). For Arregui (2005), counterfactuals of the form *if p, would q*, are *de re* claim about a past time and state that if that past time would have led (*future* w.r.t the past interval) to p, it would also have led (again, *future* w.r.t the past interval) to q.

I will thus assume that a run-of-the-mill counterfactual involves some modal *would*, which performs two functions. The first is to introduce an open time interval, which stretches from the past time given by tense and stretching to infinity. Second, it provides universal quantification over worlds, such that in all relevant worlds, an event occurs during that open interval t. I will not discuss the exact nature of the accessibility relation for this future modal: maybe it is some metaphysical relation (per Condoravdi 2001), maybe it should be done in terms of a similarity function among worlds (cf. Stalnaker 1968, Lewis 1973). For concreteness, however, I will call this accessibility MET (as in metaphysical). Focusing on real past examples for simplicity, the consequent of the sentence in (140) has the following analysis:

- (142) a. Il au.r.ait répondu
 b. He have-FUT-imp answered

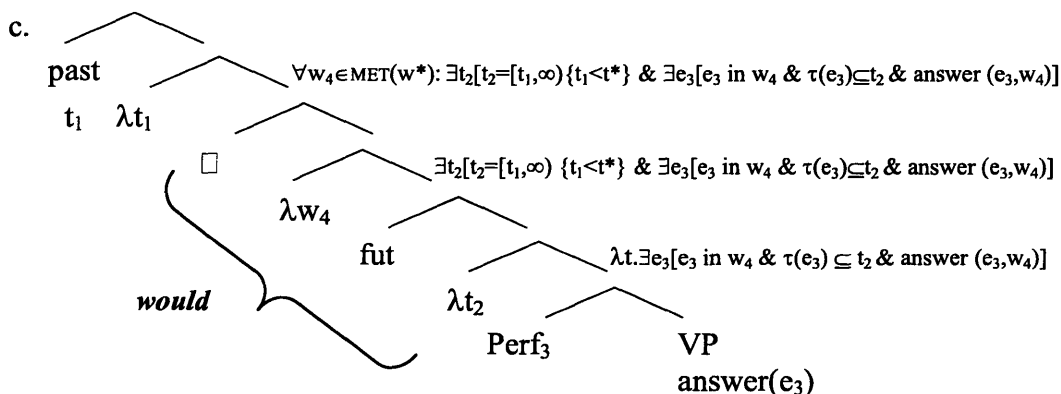

- d. In all metaphysical worlds, there is some time t_2 , future to some salient past time t_1 such that there is an event of him answering at that time t_2 .

Thus what gets spelled-out as ‘would’ in English (and as *conditionnel* in French and Italian) is the combination of a universal modal which quantifies over metaphysical worlds and a future, which introduces a new (open) time interval. Notice that in (142) our Perf is still present, but that it is under the scope of a modal element, which binds its world argument. This accounts for the fact that, in most cases of counterfactuals, the events are taken to be completed.

3.2. MORPHOLOGICAL SPELL-OUT

What is important to take from this rather long journey across the various uses of the imperfective, is that: (i) there is no single IMP operator; (ii) there is in fact no ‘imperfective’ in a semantic sense. Before spelling out the conditions for generating imperfective morphology, let us look at the overall architecture. Semantically, the functional elements seem to order themselves as follows:

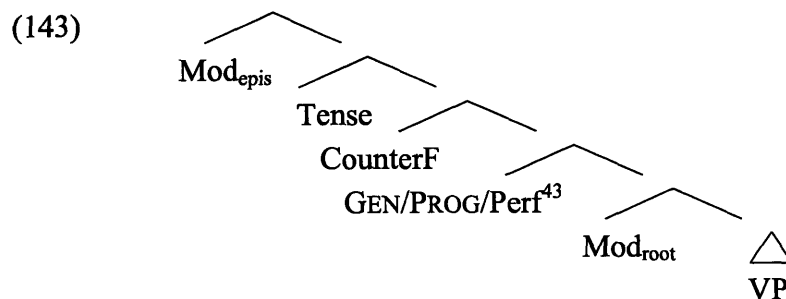

Let’s go over each of these projections. As we will see in the next chapter, Epistemics generally scope over tense. They are anchored to the utterance time, except when embedded under an attitude, in which case, they are interpreted at the internal *now* of the attitude holder. Root modals, on the other hand, are below tense and aspect. As argued above, we seem to have three different kinds of operators, associated with imperfective morphology: a counterfactual modal, GEN, and PROG. These operators all seem to be sensitive to tense: we can talk about a past habit, a past generalization or a past event in progress. Similarly, back-shifting for counterfactuals is possible, and is expressed with the pluperfect. Thus, tense seems to scope

⁴³ As we will see at the end of this chapter, Prog in fact cannot move above a root modal.

above all of these operators. The architecture in (143) also reflects the fact that we have either a PROG, a GEN or an Perf in the scope of a counterfactual modal (the counterfactual modal doesn't bind event variables, hence the VP's event needs to be bound somehow), so counterfactual modal will take scope over the former⁴⁴.

I further assume that there is no duality between perfective and imperfective, where the only difference is in the relation of the time of the event w.r.t. the reference time. We thus have only one simple (or non modal) quantifier over events (Perf), in complementary distribution with PROG and GEN:

$$(144) \quad [[\text{Perf}]] = \lambda w. \lambda t. \exists e[e \text{ in } w \ \& \ \tau(e) \subseteq t \ \& \ P(e,w)]$$

If this is the correct representation, and under the assumption that imperfective is simply some morphological spell out of the tense, I propose the following conditions to handle the distribution of the 'aspectual' morphemes, in the spirit of Iatridou (2000):

(145) **Spell-out conditions**⁴⁵: (i) When Past is immediately adjacent to Perf: spell out as perfective. (ii) otherwise, spell out as imperfective.

According to the conditions in (145), if tense and Perf are adjacent, then past will be spelled-out morphologically as 'perfective'. In French and Italian, this will be the *passé composé*, as the simple past is disappearing from the language, and is only used in literary registers. In Spanish, it will be spelled out as the *Preterito*. However, if something intervenes between Tense and Perf, such as a counterfactual modal (CF), or a progressive, the morphological spell-out of past tense will be the *imparfait*. Note that these spell-out conditions are specific to French and Italian. In Spanish, for instance, counterfactuality can be expressed with 'perfective' morphology. I leave a detailed comparison between these languages for future research. Note that these conditions differ a bit from Iatridou (2000), which proposes the following for the distribution of imperfective morphology:

⁴⁴ Given that Perf moves above a root modal, can it move above the counterfactual one? Perf needs to move right below Tense in order to combine with its time argument. In the presence of CF, however, Perf will only need to move below CF, given that the later provides a time interval for Perf to combine with.

⁴⁵ Thanks to I. Heim for this spell-out condition.

- (146) When the temporal coordinates of an eventuality are set with respect to the utterance time, the aspectual morphology is real. When the temporal coordinates of an eventuality are not set w.r.t. the utterance time, the morphology is always imperfective.

One crucial difference is that, in the current account, there is no such thing as ‘real’ imperfective morphology. If indeed there was, then, it is not clear why imperfective, rather than perfective, would be the default in the non real cases. In the current proposal, imperfective is only the elsewhere morpheme.

3.2.1. *Statives*

In all of the above cases, I have only considered eventive predicates. What about statives? The default aspect morpheme used with statives is the imperfective. With perfective morphology, we infer (in French and Italian) that the state doesn’t hold anymore (cf. introduction)⁴⁶. This falls out naturally, if we assume that statives have a state argument, which gets bound by Perf. But what happens to this state variable in imperfective cases? I would like to propose that all statives inherently select either for a PROG or a GEN. Chierchia (1995) argues that i-level predicates have a built-in feature, which forces them to be in the scope of a generic operator. Similarly, s-level predicates will select for a PROG. States, just like activities, intrinsically have the subinterval property (e.g., any subinterval of *being happy* is a *being happy* interval). Thus, the modal component of PROG shouldn’t do any semantic damage⁴⁷:

- (147) a. Darcy était saoul.
Darcy was drunk.
b. PAST(PROG(drunk(s,w) & Hold(s,D.)))
c. $\exists s[s \text{ in } w \ \& \ \tau(s) \subseteq t \ \{t < t^*\} \ \& \ \forall w' \in \text{Best}(\text{Circ}, \text{NI}, s):$
 $\exists s'[s \subseteq s' \ \& \ s' \text{ in } w' \ \& \ \text{drunk}(s', w') \ \& \ \text{Hold}(s, D.)]$
d. There is a past state s s.t. in all inertia worlds, s is a substate of a D. being drunk state.

The reader might object that in English, the progressive is almost ungrammatical with states. This could be an instance of blocking, per Chierchia (1995) for i-level predicates, where

⁴⁶ In Greek, Bulgarian and (in some cases) Spanish, perfective morphology yields an *inchoative* meaning, that is, it marks the beginning of the state, rather than the end. I put this issue aside for future research.

⁴⁷ Maybe we do not want the actual event or state to be contained within the reference time after all ($\tau(s) \subseteq t$). Another potential issue is that in chapter 3, I argue that there is some incompatibility between states and a circumstantial accessibility relation (which is the one Portner uses for the Prog).

the lack of progressive morphology would be the result of a progressive triggering feature being built in lexically. Furthermore, what could license progressive morphology is to have singular *events* (as opposed to plural ones or states). Thus states would morphologically pattern with habituais.

3.2.2. *An Alternative Spell-out Condition*

There might be a way to recast my spell-out conditions in terms of a semantic default, rather than an elsewhere morpheme. I will simply mention it here, as it will require a more involved analysis. Recall that for counterfactual cases, the past tense was supposed to be a ‘fake’ past (Iatridou 1990), or, in Arregui’s account a zero-past (in the sense of Kratzer 1998). I would like to suggest that the *imparfait* is the spell out of this bound/zero past. English only has one past morpheme. Hence, a zero past will have to be spelled out as past. But in French and Italian, this zero past will be spelled out as the *imparfait*. This is in line with the intuition that the *imparfait* is ‘anaphoric’ in nature, and is very much in the spirit of Giorgi and Pianesi (2004), for whom the *imparfait* is a present in the past. Notably, having the *imparfait* be the spell out of a bound past will account for the fact that the *imparfait* is required in sequence of tense environments (the quintessential zero past environment), even when the complement’s event is taken to be completed:

- (148) Darcy a dit la semaine dernière que Jane arrivait le lendemain.
Darcy said last week that Jane came-impf the next day.

The main challenge will be to account for the past progressive interpretations, which presumably require a real past. This is where the out-of-the-blue component comes in. Recall that the imperfective is weird out of the blue (except in counterfactual uses). It could be that we are dealing here with a case of zero tense as well, which would need to be bound by a real past tense, provided, for instance, by a time adverbial (for a proposal and discussion that time adverbials introduce time variables see Pratt and Francez 2001, von Stechow 2002)⁴⁸.

⁴⁸ Thanks to P. Anand for pointing out these references.

3.2.3. Epistemics and Aspect

Given that epistemic modals appear above tense, they will not be directly affected by the spell-out conditions above: the spell out of the tense will depend on the presence/absence of an IMP in the complement:

- (149) a. Il devait lire un livre.
He must-imp read a book
must_{epis} T PROG [read a book (e)]
'He must have been reading a book.'
- b. Il a dû lire un livre.
He must-pfv read a book
must_{epis} T Perf [read a book (e)]
'He must have read a book.'

3.2.4. Counterfactuals: Conditionnel vs. imperfective

Usually, the morphological spell-out of the counterfactual modal in French and Italian will be the *conditionnel*. However, the spell-out conditions given above will allow, optionally, the spell-out of the configuration Tense-Counterfactual-Perf as imperfective. This will handle the fact that we find no meaning difference in the minimal pair repeated below:

- (150) a. Jane pouvait prendre le train, mais elle a décidé de prendre l'avion.
Jane could-impf take the train, but she decided to take the plane.
- b. Jane aurait pu prendre le train, mais elle a décidé de prendre l'avion.
Jane could-cond take the train, but she decided to take the plane.

Note that this is a bit of an oversimplification. Ippolito (2004) points out a meaning difference between *imperfect* and *conditionnel* counterfactuality with full conditionals. Anderson (1951) had shown that with a true counterfactual, it is possible to cancel the implicature that the *antecedent* is false in the actual world (as can also be seen in the English translation). As pointed out by Ippolito (2004), this is not an option for an Imperfect Conditional (IC):

- (151) a. Se Gianni avesse preso quel farmaco, gli sarebbero venuti proprio questi sintomi.
Quindi l'ha preso.
If Gianni had-imp-subj taken this medicine, he be-imp-cond come just these symptoms. Therefore he has taken it.

- b. #Se G. prendeva quel farmaco, gli venivano proprio questi sintomi. Quindi l'ha preso.
#If G. took-**imp** this medicine, he come-**imp** just these symptoms. Hence he has taken it.
'If Gianni had taken this medicine, he would have had exactly those symptoms Therefore he took it'.

The continuation that asserts the truth of the antecedent is fine with a *conditionnel* conditional, but not with an IC. For Ippolito, the non cancelability of ICs is due to some Gricean competition between ICs and regular indicative conditionals. Note that the difference arises only in the presence of an overt if-clause. Without an if-clause, there doesn't seem to be a meaning difference between the counterfactual reading of the imperfective, and that of the *conditionnel*. I will venture the guess that the subjunctive, only present in regular (*conditionnel*) counterfactual (in Italian), contributes an additional meaning (cf. fn. 50).

4. NON IMPLICATIVE READINGS OF ROOT MODALS

I have given above an account of the distribution of the imperfective, which could explain its presence in 'modal' contexts, where the modality was counterfactual, progressive/habitual or generic. Many questions remain, and this proposal was only meant to give us some concrete elements to work with for our root modals' non implicative readings. What is important to keep in mind is that both counterfactuality and genericity are associated with imperfective morphology, and any semantics for these in general should be extendable to the two kinds of non implicative readings we obtain with imperfective on root modals. The crucial elements I need are some modal operators capable of binding the world variable of the quantifier of events, in a way that can prevent an actual event. And, as we just discussed, such modal elements are independently needed to account for the various modal meanings associated with imperfective.

As we saw in section 1, there is not a single 'non implicative' reading, but rather two main sorts of readings: a general ability, reminiscent of generic statements, and a counterfactual one. These readings can be straightforwardly derived, once we assume the covert modal operators (counterfactual and GEN) described above.

4.1. DERIVING THE ABILITY MEANING

In this section, we will focus on the ability reading of imperfective on root modals, such as in the examples repeated below:

- (152) a. Elisabeth pouvait parler aux singes.
Elisabeth could-impf talk to monkeys.
- b. Cette voiture pouvait faire du 250 km/h.
This car could-impf go 250 mph.

Given the non accidental nature of the ability attributed to Elisabeth, and given Bhatt's evidence for these readings being associated with genericity, I will assume that this reading is to be derived through a generic operator. I use the semantics for GEN given in section 3.1, and repeated below:

- (153) For σ either e or ε , for all $p, q \in D_{\langle \sigma, t \rangle}$, $f \in D_{\langle s, \langle \sigma, t \rangle \rangle}$:
- $\llbracket \text{GEN} \rrbracket (f)(p)(q)$ is true in w at t iff $\forall x \in f(w, t): p(x) \rightarrow q(x)$
where $f(w, t) = \lambda x. x$ is normal/ideal from the perspective of w at t .

We thus obtain the following:

- (154) a. Elisabeth can talk to monkeys
- b. $\forall e [e$ is normal from the perspective of w^* at t^* : if e 's preconditions hold
 $\rightarrow \exists w' \in \text{CIRC}(w^*)$ talk-to-monkeys (e, w') & $\text{Ag}(e, E.)$
'For all normal/ideal events from the perspective of w at t , where preconditions for talking to monkeys are met, there is a world w' circumstantially accessible from w^ where e is a talking to monkeys event by E .'*

The lack of actuality entailment comes from the selection function of GEN, which picks out normal/ideal events, which may not be instantiated in the actual world. In the zoo context, for instance, the preconditions might not be met: Elizabeth doesn't have to have been talking to monkeys.

This analysis can make sense of the fact that the following pair of sentences has a very similar meaning:

- (155) a. This car drives 200mph.
 $\forall e$ [e is normal from the perspective of w^* at t^* : if e 's preconditions hold
 \rightarrow drive-200mph(e , this car)
'All normal events e where preconditions such as good road conditions, the car is not broken, there is no speed limit enforcer, etc... are events of driving the car 200mph.'
- b. This car can drive 200mph.
 $\forall e$ [e is normal from the perspective of w^* at t^* : if e 's preconditions hold
 $\rightarrow \exists w' \in \text{CIRC}(w^*)$ drive-200mph(e , w , this car)
'All normal events e where preconditions such as good road conditions, the car is not broken, there is no speed limit enforcer, etc... there is a world compatible with the circumstances of that event such that e is a driving the car 200mph.'

What underlies this similarity is the same reasoning that applied to pairs of sentences involving a root *can* with perfective morphology, and its unmodalized equivalent, as illustrated below. Both sentences are true just in case Jane danced. Recall that in a sentence like ((156)a), we have an actual event which in some circumstantially accessible world is a dancing event. We infer that it is a dancing event in the actual world as well, given that it is the same event:

- (156) a. Jane a pu danser.
 Jane can-pst-perf dance
- b. Jane a dansé.
 Jane dance-pst-perf

The same reasoning applies to (155)b): all normal events e from the perspective of the actual world (and where some preconditions hold) are such that in some circumstantially accessible world they are *driving 200mph* events. Given the event identification principle, all normal events (where some preconditions hold) will basically be *driving 200mph* events.

4.2. DERIVING THE COUNTERFACTUAL MEANING

I take the counterfactual reading associated with imperfective morphology in a sentence like (157)a) below, to reflect the presence of a covert counterfactual modal, so that the sentence in (a) will be equivalent to the one in (b), where the counterfactual modal is expressed by an overt future. I think that, in these cases, we assume a default implicit antecedent clause (probably brought out by the goal-orientation of the modal), which means something like *if she had wanted to*, or *if she so desired*:

- (157) a. Jane pouvait prendre le train, (si elle voulait).
 Jane could-impf take the train, (if she wanted to).
 b. Jane aurait pu prendre le train, (si elle avait voulu).
 Jane could have taken the train, (if she had wanted to).

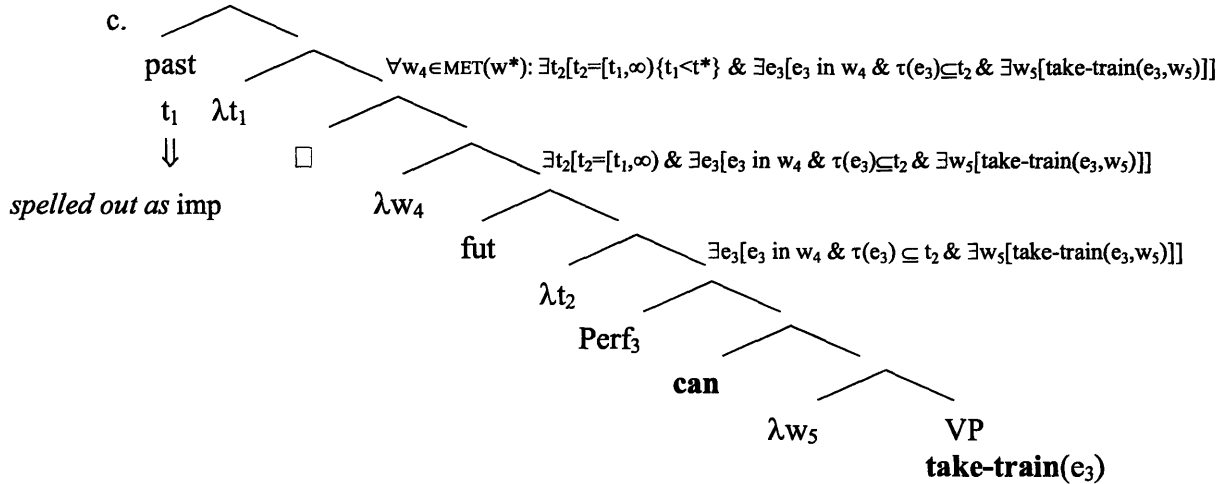

- d. ‘There is a salient past time t_1 s.t in all metaphysical worlds, there is an open time interval t_2 whose left boundary is t_1 such that there is an event e_3 , whose running time is included within the interval t_2 , which in some circumstantially accessible world is a taking the train event.’

What both (a) and (b) mean is that at some past time, if Jane had wanted to, it would have been possible for her to take the train: in all metaphysically accessible worlds, there is a world where she takes the train. This doesn’t preclude that there might have been other means to reach her goal, in all of these metaphysical worlds. We can thus continue the sentence with ‘*she could also have taken the plane*’. Note that the metaphysical accessibility relation naturally captures the future-orientation of root modals we get with imperfective.

Recall from section 3.1.3.1 that we had cases of modal auxiliaries with an epistemic interpretation with *conditionnel* morphology. Interestingly then, it appears that the orders EPIS>TENSE>COUNTERFACTUAL>PERF and TENSE>COUNTERFACTUAL>PERF>ROOT, in French at least, can be spelled out the same way: *aurait pu* or *pouvait* (possibility) and *aurait dû* or *devait* (necessity).

4.3. OTHER ‘IMPERFECTIVE’ OPERATORS ON ROOT MODALS?

We have thus seen that in the presence of a (covert) counterfactual modal, where the tense is morphologically spelled out as imperfective, we obtain a non implicative reading. We also saw that, a generic operator, where tense is again spelled out as imperfective, also yields non

implicative readings. The question now becomes whether a PROG or HAB can scope over a root modal and, if so, if we get actuality entailments. And, it appears that the answer is no. First, in Hindi, progressive on a root modal is marginal at best (P. Anand, R. Bhatt, p.c.). Second, examples such as the following suggest that we never get such an interpretation:

- (158) a. Il ouvrait la porte quand la clé a cassé. [I. Heim, p.c.]
 He opened-imp the door when the key broke
 ‘He was opening the door when the key broke’
 b. #Il pouvait ouvrir la porte quand la clé a cassé.
 He could-imp open the door when the key broke

The *when*-clause seems to strongly favor a progressive interpretation of the matrix predicate (*open* or *can open*). Indeed a counterfactual interpretation is marginal (in both the modalized and unmodalized versions), even with *conditionnel* morphology (we would prefer *if the key hadn’t broke*):

- (159) a. ??Il aurait ouvert la porte quand la clé a cassé
 He opened-cond the door when the key broke
 ‘He could have opened the door when the key broke’
 b. ??Il aurait pu ouvrir la porte quand la clé a cassé
 He could-cond open the door when the key broke

Likewise, a generic interpretation is odd with a *when*-clause (a), unless the *when*-clause picks a large enough interval itself:

- (160) a. Quand je l’ai vue, cette voiture faisait du 200 km.
 When I saw it, this car went-impf 200 mph
 ‘When I saw it, this car was going_{prog} 200 mph’
 b. Quand elle avait encore ses deux pots d’échappement, cette voiture faisait du 200 km.
 When it still had its two exhausts, this car went-impf 200 mph
 ‘When it still had its two exhausts, this car went_{gen} 200 mph’

Thus, the sentences in (158) really seem to involve a progressive and are bad with a root modal⁴⁹. It thus appears that, for some reason, which I, unfortunately, cannot explain, Progressive is unable to move above the modal, unlike Perfective aspect.

The fact that progressive cannot scope over a root modal has an interesting consequence. What happens in environments which strongly favor a progressive use? Consider the following examples (G. Chierchia, p.c.). The context is that I am moving into a new apartment and I am crossing the street back and forth. Jane is a maniac driving up and down the street:

- (161) a. ?A chaque fois que je traversais, Jane pouvait m'écraser.
Every time I crossed the street, Jane could-imp run me over
b. #A chaque fois que je traversais, Jane m'écrasait.
Every time I crossed the street, Jane run-imp me over

The sentence in (b) is bad. The presence of the *every time* clause seems to prevent a counterfactual and a generic interpretation. The only possible interpretation of the imperfective in this context is a progressive (as can be seen when we replace the achievement predicate with an activity or an accomplishment). Note that French and Italian differ from English in that progressive on an achievement forces the inclusion of the culmination point, maybe because the event is too small to break into bits. This is why the sentence is odd, assuming that once one gets run over only once. The sentence in (a) is fine, at least in comparison. Here the progressive is simply not an option for (a), thus we will allow a counterfactual, despite the environment's preference for a progressive: *Every time I crossed the street, Jane could run me over if she wanted to*'.

5. CONCLUSION

In this chapter I have covered the various uses of the imperfective. Given the range of interpretations associated with imperfective, I have proposed, that instead of finding a common semantic core for all of its uses, we treat the imperfective as some morphological default. I have

⁴⁹ One could argue that this incompatibility is due to the fact that modals are statives, and perhaps that statives are incompatible with a framing adverbial (S. Iatridou, p.c.). However, statives are compatible with a *when*-clause, as in '*When I came in, he was drunk*'. Moreover, I do not think that modals are statives, nor, in fact, belong to any aspectual class. Their aspectual behavior depends on their interpretation and the aspectual properties of their complement.

also shown that the non implicative readings of root modals associated with imperfective aspect come in two flavors: an ability one, and a counterfactual one. I derived the first from a Generic Operator and the second from a Counterfactual modal. The other main meaning associated with imperfective, namely the progressive, doesn't seem to be able to scope over root modals.

APPENDIX A – THE PRESENT TENSE

So far, I have focused on modals in the past. What happens with present tense? Do we get an 'actuality entailment'? What exactly should be entailed? What readings do we get? It should first be noted that there is no such thing as a present perfective (not to be confused with a present perfect): the present refers to the (punctual) utterance time: it would be impossible to have a whole event be contained within a fleeting point in time. As one might then expect, with present tense, we observe the same two readings as associated with the *imparfait*:

- (162) a. Elisabeth doit prendre le train (pour aller à Londres).
Elisabeth must-pres take the train (to go to London).
b. Cette voiture peut faire du 200 km/h.
This car can-pres go 200 kph.

The meaning of (162)b) is straightforward: we get a general ability reading, due to a GEN in the scope of a present: '*All normal/ideal events e from now's perspective where preconditions hold, there is a world compatible with the circumstances of that event such that e is a driving the car 200kph*'. However (162)a) is perhaps less straight forward. Intuitively (162)a) says that Elisabeth is in a situation right now s. t., if she wants to go to London, she has to take the train.

Recall that I assume that modals do not come with their own event argument (there is only an anaphoric event variable in the accessibility relation). Recall that I further assume a limited set of aspectual operators to perform quantification of a verb's event argument: Perf (perfective); GEN; PROG; CF (I take CF to be primitive: it is a universal modal involved in counterfactuality, which is usually expressed by *conditionnel* morphology). What aspectual operator is involved? It cannot be PROG: as we saw earlier, PROG cannot scope over a root modal. And indeed, a goal-oriented reading of the modal with the complement event in the progressive seems unattested (the sentence doesn't mean: '*to go to London, Jane has to be in the process of taking the train*'). It could be GEN, but that's not the primary reading that (162)a) has.

We are left with this CF. This may, at first, go against intuitions: there is nothing ‘counterfactual’ in (162)a). However, having a future-oriented/metaphysical modal on top of the root modal yields welcomed truth conditions: ‘*In all worlds compatible with metaphysical alternatives, there is a time future from now where she takes the train (e.g., to go to London)*’.

Condoravdi (2001) argues that the modal base involved in counterfactuals is metaphysical. Metaphysical readings are allowed when the property they apply to is instantiated at a time in the future of the temporal perspective of the modal. Counterfactuality arises when an issue is presumed settled and known, because, she argues, there is no other way to satisfy the diversity condition below:

(163) A context *c* with common ground *cg* can assign to a modal with temporal perspective *t* and applying to contingent property *P* a modal base *MB* only if *cg* and *MB* satisfy:

Diversity condition: There exists a world in *cg* and $w', w'' \in MB(w, t)$ s.t.
 $INST(P, w' m[t, \infty))$ and $\neg INST(P, w'', [t, \infty))$

I believe that present and *imparfait* are very close: according to Giorgi and Pianesi 2004, the latter is a present in the past. So in principle, the aspect/modality associated with *imparfait* should be accessible to *present* as well. One major difference is that one is set in the past and the other in the present: with the former, we take the outcome to be settled and hence counterfactuality arises (cf. Condoravdi 2001), whereas, with the present, things are not settled: we only have future-orientation.

Postulating this covert aspect/modal in the present tense may seem ad hoc. However, it is needed for the past, so it is actually expected to be there with the present⁵⁰. More importantly, it can actually account for the future-oriented readings below:

⁵⁰ One problem remains. Recall that with imperfective, we found the following pair truth-conditionally equivalent:

- (i) a. Jane aurait pu prendre le train, mais elle a pris l’avion.
 Jane could-cond take the train, but she took the plane
- b. Jane pouvait prendre le train, mais elle a pris l’avion
 Jane could-impf take the train, but she took the plane

We might then expect (162)a) to be equivalent to non-past *conditionnel* morphology as in (ii):

- (ii) Elisabeth devrait prendre le train.
 Elisabeth must-cond take the train

But the meanings differ: in (162)a) taking the train seems to be the only option, whereas in (ii) taking the train is the best way from the speaker’s perspective (cf. Sloman on *ought*, von Stechow and Iatridou, *in progress*, on *ought* being the English equivalent of French *devrait*). von Stechow and Iatridou actually show that cases like (ii), despite the counterfactual morphology (*conditionnel*) are not properly counterfactual: there is nothing ‘contrary to fact’. I leave

- (164) Jane part demain.
Jane leaves tomorrow.

Thus, in general, a present will be taken to be progressive. (Perfective is out independently, given that an event cannot happen within utterance time). When Progressive is not available (because of a root modal, or because of the time adverbial in (164), and GEN/HAB dispreferred, CF (the primitive metaphysical covert modal) kicks in. It performs two functions: it effects some modal quantification over metaphysical worlds (in the sense of Condoravdi 2001), and introduces a time interval that extends in the future. This large interval, in turn, allows perfective aspect to bind the event argument: the time interval is now large enough to contain the temporal trace of the event perfective aspect quantifies over. As far as the morphological spell out of the tense, it will come out as present tense morphology (Tense will never be adjacent to Perf, but rather to a PROG, GEN or a CF).

this question for future research, and simply point out that the different spell-outs might reflect an additional element carried by the *conditionnel* than the simple CF doesn't have. One potential culprit could be the subjunctive, which appears in the antecedent of counterfactuals, and which could be responsible for further removing the proposition away from reality and into the realm of wish worlds/personal preferences. After all, the subjunctive can be used to express wishes that need not be counterfactual (cf. Iatridou 2000). The (albeit archaic) sentence below expresses a wish about a proximate future which is not hopeless:

- (i) Qu'il vienne!
That he come-subj

CHAPTER 3: EPISTEMICS/DEONTICS VS. ROOTS: A HEIGHT PROBLEM

0. INTRODUCTION

As we saw in chapter 1, certain interpretations of the French and Italian possibility and necessity modals yield *actuality entailments*. The term ‘actuality entailment’, coined by Bhatt (1999), refers to the inference, which arises with perfective aspect, that the proposition expressed by the modal’s complement holds *in the actual world*, and not merely in some possible world. Conversely, the same modals with perfective, but under different interpretations, do not force such an inference. We saw that the interpretations that did yield actuality entailments were those with a *circumstantial* modal base (abilities, goal-oriented and pure circumstantials); the ones that didn’t were those with an *epistemic* or a (truly) *deontic* interpretation.

It appeared that the determining factor for actuality entailments was the relative position of the modal w.r.t. Aspect: when it is *above* Aspect, it is ‘immune’ to it. However, when Aspect (which originates from the VP) moves above the modal, we obtain an actual event. This is so because Aspect comes with its own world variable, which needs to be bound by the closest binder possible. When below a modal (as in (b)), the modal will bind Aspect’s world argument; when above the modal (as in (a)), Aspect’s world argument will have to be bound by the matrix binder, yielding an actual event. This is schematized below (we will briefly review the mechanisms involved in section 1):

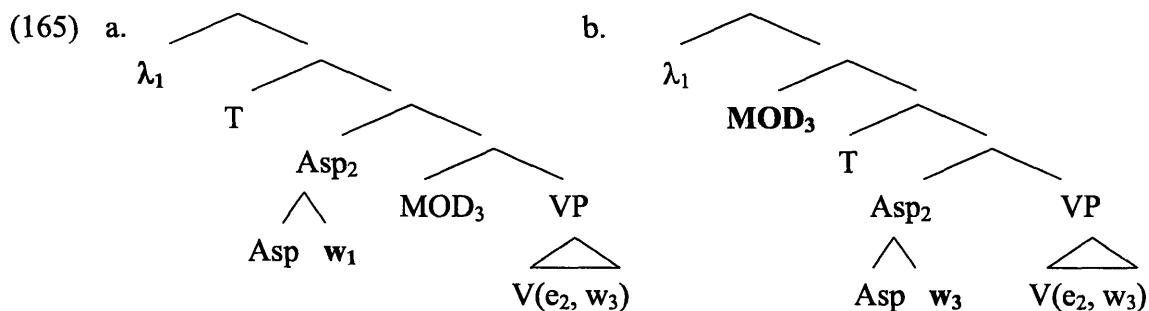

Thus, the main result from chapter 1 was that when a modal is below aspect, it yields an actuality entailment, when above, it doesn’t. What remained open, however, was why it is that in a configuration such as (a) (Aspect above), the modal is always interpreted with a circumstantial

accessibility relation, while in cases like (b) (Aspect below), the modal's interpretation can only be epistemic or deontic. This is the question we now turn to.

We saw some evidence that epistemics and deontics are interpreted above Tense and Aspect, while circumstantials are not. There are other phenomena, which, more generally, suggest that epistemics/deontics are interpreted higher than circumstantials (also called 'roots' in the literature), which we will review in section 2. However, the question of what underlies this difference in height of interpretation is still unsettled in the literature. Various accounts have been proposed to handle this 'height' problem. One prominent proposal is Cinque (1999), which argues, based on a large and meticulous survey of adverbs and functional projections across languages, that there is a universal, fixed hierarchy, which determines the relative position of functional heads, and in particular, modals. If indeed the order is fixed (i.e., an epistemic is merged above tense, a root below Aspect, etc...), then it follows that in (113a), the modal is circumstantial, while in (113b) it either is epistemic or deontic. Another line of proposals argue that epistemics are higher than roots because they take propositions as their complements, while roots take properties (cf. Jackendoff 1972, Brennan 1993, Butler 2003). Unsurprisingly, epistemics will be higher (IP-level) than roots (VP-level). The main drawback with such accounts is that they do not really *explain* why epistemics should be higher than roots (or *why* they should take propositions but not roots). Cinque's hierarchy is essentially arbitrary. One would want to understand why it is organized the way it is. Similarly, in IP vs. VP-level accounts, it is not clear why epistemics/deontics are the ones that are IP level and not VP level. Another issue with such proposals, which build in the height difference either syntactically or semantically, is that they ultimately end up with separate lexical entries for roots and epistemics, despite the fact that, cross-linguistically, they are expressed by the same lexical items. My hope with this chapter is to show that a unified semantics is attainable: the movement of aspect above the modal, which I postulated to derive the actuality entailments with root interpretations, paired with a further assumption about modals' accessibility relations, which I will make in this chapter, can in fact provide a principled explanation for this height difference, which relies on fairly natural syntactic assumptions on binding and movement.

The first step in making sense of the 'height' puzzle is to realize that the split between roots and epistemics correlates to that between subject-orientation (Su-O) and speaker/addressee-orientation (Sp/A-O). Thinking in terms of speaker/addressee vs. subject orientation rather than

root vs. epistemic/deontic again highlights the difference in height of interpretation: if a modal is speaker or addressee-oriented, it will somehow have to do with the speech act domain, whereas if it is subject-oriented, it will somehow have to do with the IP domain. Given that the speech act domain should be higher than the IP domain, we expect that, if there is a difference in height, Sp/A-O should be higher than Su-O. The question then becomes why it is that a speaker-oriented interpretation is always associated with an epistemic accessibility relation, and a subject-oriented one with a circumstantial one. Why does a speaker-oriented modal have to do with the speaker's *evidence* or *knowledge*, rather than, say, his abilities? Why do subject-oriented modals always have to do with *circumstances/facts* of the base world, rather than mental states?

Kratzer's system has the main advantage of giving modals a unified semantics, while deriving their differences through accessibility relations ('conversational backgrounds') that are contextually-determined. The semantic core of a modal auxiliary is its quantification force (existential for possibility and universal for necessity): a modal quantifies over *some* or *all* worlds among a particular set. What the accessibility relation does is pick out this set of worlds: e.g., worlds compatible with what the law says; worlds compatible with what the speaker knows... While this proposal is very appealing, both for its unified semantics, and for successfully capturing the context-sensitivity of the variability in interpretations, it may be too unrestrained. If the variability is determined by context alone, one might expect all kinds of accessibility relations. Factually, however, modality seems to be constrained in systematic ways. The accessibility relation seems not only to be relative to a world (of evaluation), but also to a time (possibilities and necessities change through time) and often to an individual (subject, speaker, addressee...). However, not any combination of times and individuals is available for all interpretations: for instance, a modal never refers to the epistemic state of the subject, but only to that of the speaker (in matrix context), or the attitude holder (when embedded under an attitude). Similarly for the temporal anchoring: the evaluation time of an epistemic seems restrained to the utterance time or the internal now of the attitude in embedded context, whereas for roots, it is provided by Tense itself. Where do these restrictions come from? It doesn't seem like they are due primarily to a conceptual problem: we can, for instance, easily conceive of talking about the epistemic state of the speaker at a time prior to the speech time (and in fact we can do so by embedding modalized sentences under attitudes).

In order to capture these restrictions, I propose to amend Kratzer’s system, by having all modals’ accessibility relations be keyed to an *event*: now, instead of taking a world argument, the accessibility relation will take an event, which will need to be bound locally. This event will provide the temporal and individual anchoring of modals (via the temporal trace and the agent/experiencer of the event). With a ‘low’ modal, the event variable of the accessibility relation will be bound by aspect, when it moves above the modal. With a ‘high’ modal, the event will be bound by the speech event (*se**) in matrix contexts, or by the attitude event when the modal is embedded under an attitude. This is schematized below:

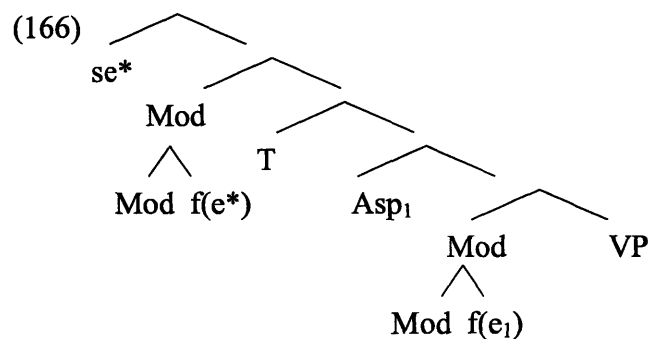

We will get the temporal/individual relativity restrictions in the following way: if the event variable of a modal’s accessibility relation is bound by the speech event, or the attitude event (when embedded under an attitude verb), it will be relativized to that event’s agent: the speaker/attitude holder (the modality will thus be speaker-oriented), and to the time of that event (the speech time). If the event variable is bound by the aspect quantifier coming from the embedded VP, it will be relativized to its agent: the subject (the modality will be subject-oriented), and to the time of the event quantified by Aspect (the time provided by Tense). I will then need to explain why attitude or speech event bound modals yield epistemic or deontic interpretations, and why aspect bound modals yield circumstantial ones. This will be done via some selectional restrictions on the type of event that needs to be bound for the different relations.

In section 1, I go over the results and assumptions from chapter 1. In section 2, I review the evidence for a difference in height of interpretations associated with epistemics/deontics vs. roots. Section 3 presents insights and drawbacks from previous accounts which try to derive this difference in height. I present my proposal in section 4.

1. BUILDING BLOCKS FROM CHAPTER 1

Let's briefly review the results of chapter 1. Instead of 'fixing' the merging order of each modal interpretation w.r.t. Tense and Aspect, as in Cinque's hierarchy, I let a modal freely merge above or below Tense. We will see that the apparent ordering rigidity arises from the type of accessibility relation available to a modal, based on what type of event binds its event argument. In chapter 1, I made the following syntactic and semantic assumptions. Modals are 'functional' heads: they are not verbs (i.e., they are not predicates of events): they all take an accessibility relation, and a proposition as their complements. I assume a referential theory of tenses and worlds: worlds and tenses are pronouns, which sometimes need to be bound, and when they do, they obey some locality principles (cf. Percus 2000, Kratzer 1998). Verbs are predicates of events, and thus need to combine with an event argument. The role of Aspect is to quantify over this event argument and to locate the time of the event w.r.t. to the time provided by Tense. I assume that Aspect is in fact a quantifier over events, of type $\langle s \langle \varepsilon, t \rangle \langle i, t \rangle \rangle$, which is merged as an argument of the verb (cf. von Stechow 2001), and then moves for type reasons, leaving a trace of type ε (for eventualities), which then combines with the predicate of events in V. Aspect then needs to move to a position right below T, in order to combine with a time argument, provided by T, to a position above a modal, if necessary⁵¹. We thus obtain the following two possible configurations:

- (167) a. Mod T Asp₁ V e₁
 b. T Asp₁ Mod V e₁

Only with configuration (b) above do we get actuality entailments. This is so because, Aspect comes with its own world argument, which needs to be bound locally. When *Aspect* is above the modal, this world variable gets bound by the default matrix binder, thus forcing the event to happen in the actual world. When the *modal* is above, it binds the Aspect's world argument (because that modal is the closest binder): the event need not occur in the actual world.

⁵¹ I'm indebted to G. Chierchia (p.c.) for suggesting that what motivates Aspect to move right below T is to combine with a time pronoun.

As we will see, when Aspect is above the modal it will bind the event argument of the modal's accessibility relation, thereby relativizing the modality to the event quantified over by aspect and indirectly its time (provided by tense) and its agent (the subject). When the syntax generates a Modal>Tense ordering, Aspect will still move out of the VP, up to a position below T, but crucially not anywhere above the modal. Thus the event argument of the modal's accessibility relation will have no choice but to be bound by the speech event (or the attitude event in embedded cases), thereby relativizing the modality to the speech time and the speaker or the addressee (i.e., the participants of the speech event).

2. SETTING APART EPISTEMICS VS. ROOT MODALS

In this section, we will review some evidence that sets speaker/addressee-oriented (Sp/A-O) interpretations apart from subject-oriented (Su-O) ones.

2.1. QUANTIFIERS AND SCOPE

Brennan (1993) shows that quantifiers can be interpreted under a modal only when it is epistemic or (*ought to be*) true deontic. With a circumstantial/ability reading, the subject cannot reconstruct (i.e., be interpreted in its base position, assuming the VP-internal subject hypothesis):

- (168) a. Every radio may get Chicago stations and no radio may get Chicago stations.
b. #Every radio can get Chicago stations and no radio can get Chicago stations.

With the epistemic reading of (168)a), no contradiction arises, suggesting that *every* is interpreted below the modal: *it may be that every radio gets Chicago stations and (it may also be that) no radio gets Chicago stations*. However, with ability *can* in (168)b), we get a contradiction: *every radio* has to be interpreted above the modal. While the example in (168) shows that with an epistemic modal, a quantifier can reconstruct, von Stechow and Iatridou (2003) argue that in fact, it must. This is their ECP (Epistemic Containment Principle), according to which a quantifier cannot bind its trace across an epistemic modal. The following pairs of sentences cannot have an interpretation where *most* or *every* is interpreted above the modal. Thus the only interpretations available for ((169)a) and ((169)b) are '*it must be the case that most of our students are home*' and '*it may be the case that every student is home*' respectively:

- (169) a. Most of our students must be home. [von Fintel and Iatridou (2003)]
b. Every student may be home by now.

Note that there are some counterexamples to the generalization that quantifiers have narrow scope w.r.t. an epistemic modal. The sentence below came up in a seminar taught by von Fintel and Iatridou in 2004. Such examples might be an argument in favor of a Beghelli and Stowell (1997) account, where the landing site of quantifiers is fixed, with the landing site for ‘each’ being higher than the epistemic position (K. von Fintel, p.c.):

- (170) Each student may be home.

In the same vein, recent work by Janneke Huitink (2006) suggests that the Dutch equivalent of ‘every’ is able to scope above epistemics. Furthermore, she shows that once contexts are carefully built, many quantifiers in fact are able to scope above epistemics, so that the ECP may just be a restriction on ‘every’ itself.

2.2. EXPLETIVES/IDIOM CHUNKS

Idiom chunks and expletives seem to again show a lack of reconstruction of the subject below the modal, when it has an ability interpretation. With an epistemic, the idiomatic meaning remains:

- (171) The shit might/#can hit the fan.

Brennan presents other arguments including VP-modifiers, symmetry predicates and *de dicto* readings of definite descriptions. I won’t go over these arguments as they are a bit more involved, and possibly not as strong as the previous two, but I refer the interested reader to Brennan (1993).

2.3. NEGATION

It has been claimed that negation also tends to be interpreted under epistemic modals. (cf. Drubig 2001). In the following examples, the modal has scope over negation. Note that in (c), when *may* has a deontic interpretation, it is most naturally interpreted below negation:

- (172) a. Darcy must not be at home.
 b. Darcy can't be home.
 c. Darcy may not be at home.

There are, here again, counterexamples to this claim. The following examples contain modals with an epistemic interpretation, which are happy to scope under negation:

- (173) a. Jane doesn't have to be at home.
 b. Jane need not be home.
 c. Jane can't be home.

2.4. TENSE

A modal cannot be interpreted in the past tense, with an epistemic interpretation (cf. Iatridou 1990, Abusch 1997, Stowell 2001)⁵²:

- (174) Darcy had to be home ✓ mod_{epi}>past, *past>mod_{epi}

This generalization is rather robust. Iatridou (1990) shows that while embedded contexts may appear as counterexamples, as the evaluation time of an embedded epistemic modal is not the time of utterance but a time prior to it, they really involve a Sequence of Tense past (i.e., a 'fake' or 'vacuous' past that results from a kind of morphological agreement with the tense of the embedding clause, but whose interpretation is really that of a present/simultaneous tense). Thus the evaluation time of the modal statement is simultaneous to that of the embedding thinking/believing time (*itself* being set in the past), and cannot be interpreted as anterior to that attitude time:

- (175) a. Lizzie thought that Darcy had to be home.
 b. John believed that his wife might become rich. [Abusch (1997)]

⁵² What Iatridou (1990) calls epistemics is different than what I have been referring to as epistemics. Thus her claim is not about epistemics in her terminology, it still is about a class of modals that we do currently call 'epistemics'.

Other counterexamples also seem to be reducible to a special case of vacuous past, where the semantic contribution of what seems to be a past tense on the surface really doesn't have the characteristic back-shifting of a past tense. Boogart (2003) claims that Dutch epistemics can be interpreted in the past tense, but all of his instances seem to be cases of narrative past/Free indirect discourse, which, again, are reducible to cases of 'fake' past.

As we saw in chapter 2, Condoravdi (2001) discusses an ambiguity in meaning between an epistemic reading (facilitated by the adverb *already*) and a counterfactual one (facilitated by the adverb *still*) in the examples below:

- (176) a. They might (already) have won the game.
b. They might (still) have won the game.

In (a), the epistemic possibility is about a past time, but is evaluated at the time of utterance: it is possible, as far as I (the speaker) know (*right now*), that (*at some past time*) they won the game. In (b), we are talking about a possibility at a past time, of an outcome future to that past time: at that time, there was a possibility that they would win the game (but we infer that they, in fact, didn't win). This is the metaphysical/counterfactual reading. Condoravdi takes the ambiguity to reflect different scopal relations between the modal and the perfect: when the modal scopes over the perfect, its interpretation is epistemic, when it is below, it is metaphysical. What Condoravdi's examples suggest is that, here again, epistemic interpretations are interpreted at the utterance time⁵³. A past evaluation time involves counterfactuality.

There are, however, potential counterexamples to the generalization that epistemics take scope above tense. In the example below, a natural interpretation of B's utterance is about a past epistemic possibility:

- (177) A : Why did you look in the drawer? [von Fintel and Gilles 2006]
B: My keys might have been in there. (=It was possible that my keys were in there)

We will return to these examples in Section 4.4, where I will argue that these examples could involve a sequence of tense past under an elided '*I thought that*'.

⁵³ This is not exactly what Condoravdi claims. For her, modals take tenseless propositions, but epistemics are in the scope of a present tense (or a zero tense) in embedded contexts.

True (ought-to-be) deontics, which put an obligation on the addressee pattern with epistemics w.r.t. tense. Recall that ‘deontics’ understood in the traditional way, really split into two groups: those that put an obligation on the subject, which I assimilate to goal-oriented modals, and those that put an obligation on the addressee (the ‘true’ deontics). Consider the following sentence:

- (178) a. Kitty a dû faire ses devoirs (pour pouvoir avoir le droit de sortir le soir).
Kitty must-pfv do her homework (so that she would be allowed to go out at night)

Here the most natural interpretation is that of a subject-oriented deontic: the obligation is on Kitty. Note that in that case we get an actuality entailment. However, the same sentence with a ‘true’ deontic interpretation doesn’t yield an actuality entailment. In fact, it is ungrammatical. The way to bring out this true deontic reading is to build a context where the obligation is clearly on the addressee rather than on the subject. If I am addressing the babysitter and talking to her about her childcare duties, I can use neither (179)a) (*must*), nor (179)b) (*to be supposed to*, which cannot have a goal-oriented interpretation), with perfective aspect (regardless of whether the complement took place in the actual world or not). Note that, if I wanted to reproach the babysitter for failing at her obligation I should use some counterfactual marking:

- (179) a. ??Kitty a dû faire ses devoirs, (mais elle ne les a pas fait/et elle les a fait).
Kitty must-pfv do her homework, (but she didn’t do it/and she did it.)
b. ??Kitty a été censée/supposée faire ses devoirs, ^{ok}mais elle ne les a pas fait
Kitty was-pfv supposed to do her homework, but she didn’t do it

This fact is corroborated by English *must*, which, for many English speakers, seems to be restricted to a true deontic, or an epistemic reading. As Ninan (2005) shows, *must* in the following sentence cannot have a deontic interpretation, but only an epistemic one, indicating that deontic *must* cannot be interpreted in the past. Note that with an epistemic reading, the sentence is fine, but the modal is evaluated at the speech time, not in the past:

- (180) Lydia must have gone to confession.

This data suggests that in the case of true deontics, as with epistemics, cannot be interpreted below Tense. Both are evaluated at the speech time (or the internal now of the

attitude, when embedded). The reason why (180) is fine with an epistemic reading is that it is conceptually fine to *report* a (current) epistemic state about a past state of affairs, whereas it is not possible to *request* someone to bring about a past state of affairs (cf. Ninan 2005).

Thus, it appears that different interpretations of the same modal auxiliaries yield different ‘heights’ of interpretation: an epistemic can (and maybe must) be interpreted above a quantifier. Both epistemics and true deontics cannot be in the scope of a past tense. Root interpretations on the other hand can (and in fact must) scope under a past tense, and are not able to ‘scope’ above their subject.

2.5. SPEAKER VS. SUBJECT RELATIVITY

Let’s review briefly the sorts of accessibility relations involved in modal statements. An epistemic accessibility relation traditionally relates a world to a set of worlds compatible with what the person whose epistemic state we report knows in that world. For instance, if I say ‘*Darcy must be home*’, I am claiming that in all states of affairs (or worlds) that are compatible with what *I*, the speaker, know, Darcy is home. What I know will include propositions such as ‘Darcy’s lights are on’, ‘Today is Sunday’, ‘Darcy never works on Sundays’, and exclude propositions such as ‘Darcy is in Paris right now’, etc... In a matrix context, the person whose epistemic state the modal statement reports is always **the speaker** (and perhaps a slightly larger community, including the speaker, cf. DeRose, 1991⁵⁴). When embedded under an attitude verb such as *think* or *say* the epistemic state is that of the attitude holder, Lizzie’s, in ‘*Lizzie thinks that Darcy must be home*’ (cf. Stephenson 2005).

A deontic accessibility relation yields worlds in which certain laws or rules are obeyed. Recall the split between what I called true deontics (when an obligation is put on the addressee) and subject-oriented deontics (which pattern with goal-oriented modals). The former do not yield actuality entailments, while the latter do.⁵⁵ The sentence below is ambiguous between the two

⁵⁴ I am simplifying a bit by avoiding the issue of so-called relativism in epistemic modals, which has recently taken a prominent space in the epistemic literature, as it is somewhat orthogonal to the main empirical facts I am trying to account for. It has been proposed (e.g., Egan et al 2004, MacFarlane 2003) that epistemic modals are not simply evaluated with respect to a world and a time but to an assessor parameter, such that a sentence involving an epistemic will be judged true or false depending on the information state of the person who evaluates the sentence (not the speaker’s). I am not convinced that the evidence that these proposals rest on warrants the addition of such a parameter in the index, but, should it be required, it is, in principle, compatible with the account I propose here. For a review of such proposals, cf. von Stechow and Gillies (2006).

⁵⁵ This split roughly corresponds to Feldman’s (1986) *ought to be* vs. *ought to do* deontics.

readings. If it is addressed to Lydia's babysitter, then the obligation is put on **the addressee** (the babysitter). With a subject-oriented interpretation, the obligation is on the **subject**:

(181) Lydia must brush her teeth.

Goal-oriented, subject-oriented deontic, ability, and purely circumstantial modals all involve a circumstantial accessibility relation. What this relation does is consider worlds in which certain facts or circumstances of the base world hold. The following sentences illustrate:

(182) a. Jane can lift this table.

b. Jane can take the train to go to London.

c. Hydrangeas can grow here.

[Kratzer 1981]

In all of these statements, we are talking about a possibility *given certain circumstances that hold in the actual world*. For (a) these circumstances are e.g., the weight of the table, Jane's physical make-up, the law of gravity, and these will remain constant in all accessible worlds. In (b) the circumstances are Jane's current location, the fact that there are rail tracks from here to London, the train schedule, etc... (We furthermore eliminate from the set of accessible worlds, all of those in which Jane doesn't go to London). In (c) the circumstances involve the quality of the soil, the climate, etc... In all of these cases, these circumstances seem to be relativized to a certain individual, namely, **the subject** and sometimes **the location**: In (a), we're looking at **Jane's** abilities, in (b) **Jane's** location and goals, in (c), properties of the kind **hydrangeas** and that of the location **here**. Thus while *Jane* can lift this table, given her athletic built, *Lizzie* may not be able to; while *Jane* can take the train to go to London, *Lizzie* may not be able to, given her stricter time schedule; and while *hydrangeas* can grow *here*, they may not be able to grow *there*. Alternatively, *roses* may be able to grow *there* but not *here*, given their greater need for water.

Interestingly then, all of the interpretations of the modal auxiliaries seem to relativize an accessibility relation to an individual. In the case of epistemics and ought-to-be deontics (Sp/A-O), this individual is a participant of the speech act. In the case of root/circumstantial modals, this individual is the subject of the clause (and other participants (including location) of the event

in the VP)⁵⁶. Note that if we have a projection of the speech act in the syntax (in the spirit of Ross 1970, and consequent work by Tenny and Speas 2004, a.o.), we observe again a difference in ‘height’ of the interpretation of the modal: with roots, the modality is anchored to an individual at the IP level (at the highest), with S/A-O, it is anchored to an individual at the speech act level. In section 4.2.1., we will go into more details about this speech act projection, and the syntactic/semantic issues tied to such a syntactic projection.

Finally, it is worth noting certain gaps in the interpretations we get. For instance, we don’t understand ‘*Jane may be home*’ as ‘*Jane is home according to the best of Jane’s knowledge*’. In other words, an epistemic accessibility relation doesn’t report the subject’s epistemic state. Similarly, circumstantial modals don’t deal with capacities of the speaker or the addressee. Thus, Sp/A-O modals do not deal with capacities, and Su-O modals do not deal with knowledge. Why should that be? We will return to these questions in section 4.3.

3. PREVIOUS PROPOSALS

In the previous section, we noticed a split between epistemic and root modals, which appears to correlate with a difference in height of interpretation. One way to go is to deny any connection between them. This is a relatively common move in the epistemic literature. For Westmoreland (1998) and Drubig (2001), for instance, epistemic modals are not necessity/possibility operators like the other modals, but evidential markers. However, if one wants to preserve a unified account of modal auxiliaries, given the cross-linguistic tendency to use the same lexical items to express epistemic and root modality, how can we derive a height of interpretation difference? Several syntactic accounts have been given to derive this difference. Based on the syntactic ordering of modals and various adverbs, Cinque (1999) argues that different modals occupy different positions on a syntactic tree, their position being determined by a fixed universal hierarchy. One major setback with this proposal is that, as it stands, nothing connects all of these different modals: ability *pouvoir* and epistemic *pouvoir* are two independent lexical items, with their own selective restrictions. While Cinque’s generalizations are rather impressive and seem to hold almost without exceptions, we would like to understand (i) what forces this hierarchy,

⁵⁶ Certain circumstantials can lack a proper subject, such as ‘*it can rain hard around here*’. In this case, we seem to be dealing with properties of the location. As we will see, the correct ‘individual’ relativity is not so much in terms of speaker vs. subject but more in terms of participants of the event (including the location).

and (ii) what all these elements have in common⁵⁷. Furthermore, this very detailed hierarchy doesn't readily explain why all roots pattern a certain way, nor why ought-to-be deontics pattern with epistemics.

Another syntactic distinction that has been offered in the literature is to divide modals into two broad-classes: VP-level vs. S-level modals. Building from work by Jackendoff (1972), Brennan (1993) proposes that epistemics and ought-to-be deontics are S-level modals, and root modals (including *ought to do* deontics) are VP-level. The difference between the two, she claims, is that the former take propositions as their complements and the latter take properties⁵⁸.

3.1. BRENNAN (1993)

In Brennan's system, modals have different types: they can either be merged at the VP level, thus take a complement of type $\langle e, st \rangle$, in which case they will yield a root meaning. Or, they can be merged at the IP-level, take a complement of type $\langle st \rangle$ and then yield an epistemic meaning⁵⁹.

In order to account for differences between roots and epistemics, and to further capture the subject-orientedness of the former, Brennan proposes a new sort of conversational background f_x specifically for root modals, which is **keyed to an individual** (the subject). This accessibility relation takes, on top of a standard world argument, an individual argument. Recall that, in her system, a root modal combines with a predicate of individuals. When the subject combines with the modal, it will, at the same time, combine with the accessibility relation. This conversational background f_x will thus consist of properties (rather than propositions) of the subject, *in virtue* of which the subject realizes the complement. This set of properties will be contextually given (the same way the accessibility relation in a standard account is provided by context). In uttering a root modal sentence, a speaker typically relies on (background) information/properties of the syntactic subject:

(183) Darcy is strong and practiced swimming at an indoor pool all winter. He **can** swim across this lake in half an hour.

MB: λx x is strong & x practiced...

⁵⁷ For other proposals that try to motivate Cinque's hierarchy, see Butler 2005b, Morzycki 2005, Nilsen 2003.

⁵⁸ See also Butler 2003, 2005a for a proposal where epistemics are above T and roots below T, and where CP layers are interspersed above vP and TP.

⁵⁹ Brennan doesn't assume events in her ontology and doesn't discuss aspect.

In (183) the modal base will thus consist of the properties of being strong, practicing in an indoor pool all winter, etc.

Brennan formalizes this accessibility relation as follows:

- (184) Conversational Background f_x (in virtue of) his physical properties: Function f from $W \times D$ into the power set of the power set of $W \times D$, which assigns to any world/individual pair $\langle w, d \rangle$ in $W \times D$ the set of all those (relevant) physical properties that d has in w .
Acc. for d : a world w' is acc. from a world w for an ind. d , $\langle w, d \rangle R w'$ iff $\langle w', d \rangle \in \wp$
(where \wp is an arbitrary property-denoting expression restricting the modal)

This effectively captures the fact that with root modals, the modality is typically subject-oriented. Her system further allows us to derive the difference in behavior between roots and epistemics. Consider the reconstruction facts repeated below:

- (185) a. Every radio may get Chicago stations and no radio may get Chicago stations
b. #Every radio can get Chicago stations and no radio can get Chicago stations

With the root reading in (b) 'every radio' has a set of properties that enables it to get Chicago stations; it then becomes inconsistent to say that the same set of properties doesn't enable them to get Chicago stations. An epistemic interpretation is immune to this since the modal takes an entire proposition: it may be that every station gets Chicago stations and it may be that none of them do (there is a world compatible with my knowledge where they all do and one where they all don't).

What this proposal essentially amounts to, is to say that root modals are control predicates while epistemics are raising predicates. Unsurprisingly then, a root modal will destroy an idiom the same way a control predicate does:

- (186) a. #The shit can hit the fan.
b. #The shit wants to hit the fan.

As we will see shortly, however, there is syntactic evidence that all modals should in fact be raising predicates. Before we turn to this evidence, one may wonder why it should be that a VP-level modal yields a root meaning and an IP-level modal an epistemic one. According to Brennan, it isn't that VP-modals express root modal meanings and S-level epistemic because of

their *lexical meaning*, but rather that it make sense to use VP-modals to talk about abilities and dispositions because the community of language users recognizes such things:

‘The connection between the category of the modal operator’s argument and the interpretative class of the resulting sentence is *not* grammatical, but results from what range of things can reasonably be construed as modal properties [and] modal propositions (...), given our world view’.

Still, why should that be? Why don’t we, as a community of speakers, construe epistemics as modal properties? Given that we theoretically have an option for control or raising, how do we ensure that all and only root modals are control predicates? Why can’t we have a root with an epistemic meaning? If root modals only look at properties of the subject, we can easily derive that they are all control predicates. The problem is to ensure that *only* root modals are control. What prohibits an epistemic modal to take a property of individuals/events and an individual to yield the same meaning as if it had taken a proposition?

- (187) a. $[[\text{can}_{\text{epis}}]] = \lambda P \langle \text{st} \rangle. \exists w': P(w') = 1$
 b. $[[\text{can}_{\text{epis/control}}]] = \lambda P \langle \text{e, st} \rangle. \lambda x. \exists w': P(x)(w') = 1$

What prohibits a lexical entry such as (187)b) could be a principle of economy stating that predicates cannot take too many arguments (cf. von Stechow and Heim 2002). Given that (187)a) and (187)b) are equivalent, the grammar would then choose the one argument version⁶⁰, under certain assumptions of economy.

3.2. ISSUES OF RAISING VS. CONTROL

Even if we can work out a system to rule out control epistemics, the assumption that (some) modals could in fact be control predicates is controversial. Bhatt (1998) and Wurmbrand (1999) have argued independently that there cannot be such a distinction in the syntax for deontics. They both argue that all deontic modals are raising predicates and, thus differences between *ought-to-do* vs. *ought-to-be* deontics should arise from some ‘semantic’, rather than ‘syntactic control’. Whoever is the carrier of the obligation will be determined by context. Note that their evidence may not directly support the claim that *all* deontics are raising predicates, given the way I have cut the deontic pie. Recall that I treat addressee-oriented deontics as fundamentally

⁶⁰ Thanks to K. von Stechow for pointing out the problem and suggesting the economy principle.

different from subject-oriented deontics: the former are anchored not to the subject, but to a participant of the speech act, i.e., the addressee, while the latter are reducible to *goal-oriented* modals: they have a circumstantial modal base and are keyed to the subject. As many of Bhatt and Wurmbrand's examples can arguably be reducible to cases of *addressee-oriented* deontics, the option that goal-oriented modals are control would still be left open. However, we will see some cases of circumstantial modals which require a raising analysis. If we need a raising analysis for *some* circumstantials, and can extend it to all circumstantials, then it should be the preferred theory.

With the examples below, Bhatt (1998) and Wurmbrand (1999) illustrate some uses of deontic modals which could not possibly involve a control predicate:

- (188) a. There have to be 50 chairs in this room. [Bhatt (1998)]
 b. The biscuits may be finished by Paul. [Wurmbrand (1999)]

Another argument common to both Wurmbrand and Bhatt involves quirky case in Icelandic and Hindi respectively. They show that the case of the subject is determined by the embedded predicate, and not by the main predicate (modal), therefore patterning with raising predicates (such as *seem*), rather than control ones (such as *hope*). The following example illustrates:

- (189) a. Haraldur/ *Harald vonast til að vanta ekki peninga. [Wurmbrand (1999)]
 Harold-NOM/*Harold-ACC hopes for to lack not money
 'Harold hopes not to lack money'.
 b. Harald virðist vanta ekki peninga.
 Harold-ACC seems lack not money
 'Harold seems not to lack money'.
 c. Umsaekjandann verður að vanta peninga
 The-applicant-ACC must to lack money
 'The applicant must lack money (to apply for this grant).'

The predicate *lack* assigns accusative case to its subject: this case assignment is preserved when the subject raises with *seem* and *must* but cannot hold with a control predicate like *hope*: in a control structure, (nominative) case is assigned by the control predicate, regardless of the case the embedded predicate would normally assign.

Hackl (1998) similarly argues that some *ability* ascriptions require a raising analysis⁶¹ and thus, by Occam's razor, we should prefer a unified raising analysis for all ability ascriptions. The following example involves a circumstantial modal with a weather predicate in its complement (a) which is usually weird with control (b), but not raising (c) predicates:

- (190) a. It can rain hard. [Hackl (1998)]
b. *It tried to rain hard.
c. It seemed to rain hard.

Given that circumstantials are the most control-like modals, if we can give them a raising analysis, we can safely assume that all modals are raising and not control. However, the case might be harder to make with more standard ability modals, such as those discussed in Brennan (1993). As we saw, the idiom chunks and the scope evidence of the previous section suggest that root modals are best analyzed as control predicates. There is a way, however, to derive the control-like behavior of root modals, while maintaining a unified syntactic account of modal auxiliaries, where they are all raising predicates (Dominique Sportiche, p.c.). The subject would be base-generated below the modal. However, when it raises (presumably for EPP reasons), it creates a new binding possibility for Brennan's individual argument (assuming that it is some sort of a zero pronoun) in the modal's accessibility relation. Given that it would be the closest binder, it would have to bind that individual variable. Once this binding relation occurs, no reconstruction is then possible, precisely because of this binding relation. Consider a parallel example:

- (191) a. Every girl seems to be happy.
b. Every girl seems to herself to be happy.

We have a scopal ambiguity in ((191)a). It either means that (i) for every girl, it seems that she is happy, or (ii) it seems that every girl is happy. In ((24)b), however, *every girl* now binds *herself*. The subject cannot reconstruct: only the wide scope of *every girl* is available. Similarly for a quantifier and a root modal. Once every radio binds the individual argument of the modal's accessibility relation, it cannot reconstruct:

⁶¹ The topic of what an ability is rather tricky. For a survey of philosophical and linguistic issues, and an interesting proposal, see Thomason (2005). Hackl's notion of ability is a bit broader than is traditionally assumed. However, the point still holds for pure circumstantials.

(192) [Every radio₁ can_{x1} [t₁ get Chicago stations]]

To sum up, Brennan's account derives the difference between epistemics and roots by proposing that the latter has a special accessibility relation, which is 'keyed' to an individual: the subject. While we can unify the syntax of all modals, as we just saw, and treat them all as raising predicates, this account, as it stands, still postulates a special accessibility relation just for roots. And while the proposal then derives the fact that root modals are subject-oriented, it still doesn't explain why epistemics cannot be subject-oriented, nor can it explain the temporal constraints on each type of modals.

4. PROPOSAL

As we saw, Brennan (1993) proposes that *root* modals are relativized to an individual, namely the subject. However, we also saw that epistemics and deontics seem to also be anchored to an individual, namely the speaker and the addressee. Thus, one unifying move would be to make *all* accessibility relations relative to an individual, and not just root modals (I. Heim, p.c.). We would have an individual argument in the accessibility relation, which could be bound either by the subject (in the case of root modals), the addressee (for deontics), or the speaker (for epistemics). Notice however, that on top of being relativized to an individual, an accessibility relation seems also relative to a time: what used to be a possibility at time *t* may not be one at time *t'* (cf. Ippolito 2002, Condoravdi 2001). One way to anchor an accessibility relation in time is to relativize it to an event(uality). This is precisely what I propose: every accessibility relation takes an eventuality argument, which needs to be bound. Notice that once we relativize the accessibility relation to an event, we can recover the information about its agent/experiencer and its temporal anchoring (relativizing the modality to an individual and a time will become redundant). Furthermore, by relativizing the modality to an event, rather than a time and an individual, we capture the fact that not any individual-time pair will do: if the modality is speaker-oriented, it will also be anchored to the time of utterance (the agent and time of the speech event). If, on the other hand, the modality is subject-oriented, it will be relative to the time provided by tense (the agent and temporal argument of Aspect). In the next section, I will spell out how to anchor the modality to an event, and discuss the binding possibilities that arise.

In section 4.2, I will go over the various accessibility relations, and recast them in terms of events. Section 4.3 discusses the various constraints on the combinations of binding events and accessibility relations. In Section 4.4, I will show how our proposal fares w.r.t. the scope issues we discussed in section 2.

4.1. BINDING POSSIBILITIES OF THE ACCESSIBILITY RELATION’S EVENT VARIABLE

The role of an accessibility relation is to provide a set of worlds, which the modal quantifies over. Recall that in a standard Kratzerian system, the accessibility relation relates a set of worlds to a world of evaluation. For instance, an epistemic accessibility relation picks out worlds compatible with what the speaker knows *in the base world*. We also saw that Brennan (1993) proposes that some accessibility relations, instead, relate a set of worlds to a world and an individual. I now propose that all accessibility relations relate a set of worlds to an *event*:

$$(193) \quad R_f := \lambda e. \lambda w. w \text{ is compatible with } f(e)$$

We will turn to what is meant by ‘compatible with $f(e)$ ’, and what the f will be for each type of accessibility relation (epistemic, deontic, circumstantial) in section 4.2. Note that all modals’ accessibility relations will be of the same type, giving all modals a unified analysis:

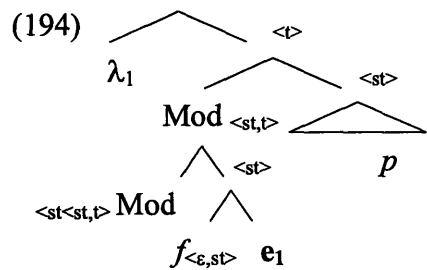

Importantly, the variable e in the accessibility relation needs to be bound locally (more exactly, it has to be *co-indexed* with its *closest* binder). Let’s look at the binding possibilities. First, what are possible event binders? One is Aspect (again, so long as Aspect and the event pronoun it binds are coindexed). This is analogous to the binding of pronouns in the individual domain (e.g., ‘*every boy_i loves his_i mother*’). I would like to propose that attitude verbs can also bind free event variables. We saw that Percus (2000) took attitudes to be world binders (situations in his system). It has further been argued that attitudes are verbal quantifiers which

can bind tense and person variables in their complements (cf. von Stechow (2002), building on Schlenker (1999) and Heim (2001)): attitudes quantify over $\langle x,t,w \rangle$ triplets and delete the features of the variables that they bind at LF. This type of analysis has been motivated by data which show that, often, the tense, world and person features in the complement of attitudes verb do not seem to be interpreted (the way they are in matrix context, for instance). The following sentence, understood *de se*, means that Darcy hopes that *himself* (rather than *Darcy*—a subtle difference that matters in cases of misidentity) wins at his internal now (rather than the utterance time—whose value he might also have misidentified). Importantly, then, the indicative mood, present tense and 3rd person features are not interpreted in the complement. This deletion of features occurs via binding of the relevant variables by the attitude.

- (195) Darcy₁ hopes he₁ wins [von Stechow 2002]
 a. hopes^{ind.pres.3} $\langle 4,5,6 \rangle$ [... w₄^{ind} t₅^{pres} he₆³ wins]
 b. hopes^{ind.pres.3} $\langle 4,5,6 \rangle$ [... w₄^{ind} t₅^{pres} he₆³ wins] *morphological agreement*

I would like to propose that attitudes can bind a free event argument (in a modal’s accessibility relation). From this event (or state), we will be able to recover an individual and a time (the experiencer and temporal trace of the attitude event). In section 4.2.1, I will sketch a way to adapt von Stechow’s theory in a way that will incorporate events.

Finally, I assume that we have one last binder: the speech event. Every utterance has one speech event, at the topmost position (cf. Ross 1970, Rizzi 1997, Cinque 1999, a.o.). Here again, from this event, we can recover a time (the speech time) and an individual (the speaker or the addressee). Thus, in a sentence involving an attitude predicate, we have three possible event binders: λ_1 , given by the speech event; λ_2 , provided by the attitude; and λ_3 , provided by aspect:

- (196) λ_1 ATT λ_2 T Asp λ_3 V e₃

Recall that there are two possible positions for a modal: either above T (as in ((197)b)), or below T (as in ((197)a)), in which case, Aspect moves above the modal:

- (197) a. [T [Asp₁ [Mod [VP t₁
 b. [Mod [T [Asp₁ [VP t₁

Putting the two together, we obtain the following:

(198) λ_1 ATT λ_2 [Mod f(e_4) [T [Asp λ_3 [Mod f(e_5) [V e_3

What are the binding options for e_4 and e_5 ? Assuming that the same binding restrictions apply for events as for worlds, these free event pronouns will need to be bound by the closest binder possible. For e_5 , this will be Aspect⁶²; for e_4 , it will be the attitude. If no attitude verb is present, e_4 will have to be bound by the speech event (λ_1). We further have to enforce that these event variables be co-indexed with their closest binder, presumably for syntactic locality reasons: the derivation will crash if this local co-indexing doesn't happen. Thus, the following LFs will be ruled out:

(199) a. $*\lambda_1$ ATT λ_2 Mod f(e_1) T Asp λ_3 V e_3
 b. $*\lambda_1$ ATT λ_2 T Asp λ_3 Mod f(e_1) V e_3

We can now reformulate Percus' binding principles, and apply them to both world and event pronouns. All free event/world pronouns on the T, M, A, V spine have to obey the following:

- (200) (i) A free variable has to be bound by its closest binder.
 (ii) If a variable is not coindexed with its closest binder, the derivation crashes.

These binding possibilities will thus restrict the range of interpretations. When the modal is above Tense, the event variable of its accessibility relation will have to be bound by (i) an attitude predicate, if there is one; or (ii) the speech event otherwise. When the modal is below Tense, the event variable of its accessibility relation will have to be bound by Aspect. When the event is bound by the attitude event, the modality will be relativized to the attitude holder at his/her internal now: the agent and temporal trace of the attitude event. When it is bound by the

⁶² One may worry that we have a case of weak crossover here, where aspect moves up from under the modal, above it, and from that position, binds the event argument of the modal. QR for instance doesn't allow such things:

(i) His_i mother loves every boy_i

However, weak crossover seems restricted to A'-movement, while our Aspect movement is A-movement. Recall that what motivates this movement is not the binding of the free event variable, but a need to combine with its temporal argument. This situation then is analogous to (ii) (rather than (i)), which involves A-movement of the subject, motivated, presumably for EPP-reasons:

(ii) Jane_i seems to herself_i to t_i be happy.

speech event, the modality will be relativized to the speaker and to the speech time (the agent and temporal trace of the speech event). When it is bound by aspect, it will be relativized to the subject and the time provided by Tense (again, the agent and temporal trace of the event quantified by Aspect).

The following example illustrates:

- (201) Jane a dû prendre le train.
 Jane must-pst-pfv take the train
- a. *Given my evidence now, Jane must have taken the train* [epistemic]
 - b. *Given Jane's circumstances then, Jane had to take the train* [goal-oriented]

The sentence is ambiguous between an epistemic reading and a goal-oriented reading. We see that with the epistemic interpretation, the modality is relativized to the speaker's evidence at the time of utterance, while with the goal-oriented interpretation the modality is relativized to Jane's circumstances at a past time. In the remainder of this chapter, I will try to justify why an attitude/speech event-bound modal can only have an epistemic or true deontic interpretation, and why an aspect-bound modal can only have a circumstantial interpretation.

Before we look into the various accessibility relations, a note is in order regarding this free event variable. Recall that I am treating modals as functional elements rather than verbs: they are not predicates of events. However, they do have an event variable in the accessibility relation. What would prevent an event quantifier (e.g., perfective aspect) to merge in this position and then move to T (assuming the modal is below T)? Maybe nothing prevents it to merge there, but something prevents it to move out (K. von Stechow, p.c.). I would like to speculate that the accessibility relation of a modal is in an island for extraction. We know, for instance, that neither covert movement (as in (202)a)) nor overt movement (as in (202)b)) is allowed out of an *if*-clause (which also restricts a modal):

- (202) a. If every boy_j comes, his_{i/*j} mother will be happy.
 b. *Who_i if t_i comes, will Mary be happy?

Given that our event argument is in the modal's restriction, if aspect were to merge there, it wouldn't be able to get out. Thus only a free event pronoun could be in this position, and it will be able to get bound by a binder c-c-commanding it (the way, for instance, *every boy* can bind *his* in '*every boy_i will be happy if his_i mother comes*').

4. 2. ACCESSIBILITY RELATIONS

In this section, we will go over the three main accessibility relations required to account for the data at hand, namely, the epistemic, the (true) deontic and the circumstantial modal bases. I assume that a Kratzerian ordering source will further restrict the set of worlds, and bring out further differences in meaning among, for instance, the various types of circumstantials (teleological, deontic...).

4.2.1. Epistemics

The first accessibility relation I will focus on is the epistemic one. Let's start with an example:

(203) (In view of what I know/believe,) Jane may be in Paris.

To understand how (203) works, we need to understand what 'what I know/believe' means. What I know in a particular world w (the actual world in the above example) is a set (call it \wp) of propositions that I believe to be true in that world w :

(204) $\wp = \{ p \mid p \text{ is a belief of mine in } w \}$
= {that Jane is out of the country; that Jane has relatives in France; that Paris is in France...}

The sentence in (203) claims that there is a world compatible with what I know in which Jane is in Paris. That is, among the worlds in which the propositions of \wp are true, there is one in which Jane is in Paris. Or, more formally:

(205) $\exists w' \in \cap \wp : \text{Jane is in Paris in } w'$

Traditionally, the fact that we are talking about my (the speaker's) epistemic state is simply wired in: this information is to be recovered from the conversational background. However, this over-generates. As the following examples show, the individual whose epistemic state we are reporting is not always the speaker, and yet, cannot take any value. In fact, it appears that the process is sensitive to syntactic (locality) factors:

- (206) a. Every boy₁ thinks he₁ must₁ be stupid [Stephenson (2005)]
 b. John₁ thinks he₁ must₁ be stupid
 c. Every contestant₁ thinks he might₁ be the winner [Speas (2004)]

In the above sentences, the epistemic state that the modal is reporting is that of each boy in (a), that of John in (b), and that of each contestant in (c). Stephenson (2005) argues that the reason why the epistemic state is the attitude holder's is that epistemics have a judge parameter in the index, and that attitude predicates are able to overwrite this judge parameter. The problem with this view is that it prevents maintaining a single analysis for epistemics and other interpretations of the same modal auxiliaries. Furthermore, Stephenson's judge parameter approach doesn't address the temporal anchoring provided by the attitude. The hope with my event relativization proposal is to be able to recover the anchoring of the modality to the attitude holder and the attitude time from the attitude event.

4.2.1.1. Attitude Verbs

We thus need to turn to the semantics of attitude verbs. Let's start with a simple example (without a modal in its complement):

- (207) Darcy believes that it is raining.
 In all worlds *w*' compatible with Darcy's beliefs in *w*, it is raining in *w*'

What is an attitude like *believe*? The literature on attitude predicates tends to abstract away from aspectual issues. However, assuming that attitude predicates are verbs, they will have aspectual properties, and will need to combine with aspectual operators. Thus like any other verb, it will have an eventuality argument (a state, in the case of *believe*).

Attitudes, however, crucially differ from other states such as *love* or *be drunk* in that they refer to a mental state which has 'content'. In the tradition of Hintikka (1962), Lewis (1983), Stalnaker (1984), we talk about the *content* of an attitude, and by that we mean a set of beliefs, desires, or hopes, which we encode via propositions (that the Earth is round, that the Earth is a planet...). Thus, we both need a physical sort of notion of a state for the Davidsonian argument, whose primary role is to provide a spatio-temporal location, and a mental 'contentful' kind of state, made up of propositions. How can we connect the two? I propose to link these two notions

by using a regular Davidsonian state, but associating to it a content (a set of beliefs, desires...) ⁶³. This will allow us to locate in time and space the content of a mental state, that is, a set of beliefs/desires that its holder has at a certain point in time and space.

We can thus recast (207) as follows (simplifying the semantics of Tense and Aspect):

(208) Darcy believes that it is raining.
 $\exists s [s \text{ in } w^* \ \& \ \tau(s) \supseteq t^* \ \& \ \text{belief}(s, D.) \ \& \ \text{in all worlds } w' \text{ compatible with the content of } s, \text{ it is raining in } w']$

(208) states that ‘there is a state experienced by Darcy at a particular point in time and space, which is a belief state, such that all worlds compatible with the content of that belief state are raining worlds’. What is the content of a belief state? It will essentially be similar to our \wp in (204): it is a set of beliefs that the attitude holder has in the base world. I propose to formalize this via a CON(s) relation, which picks out the CONTENT of a belief state s. Thus:

(209) $\exists s [s \text{ in } w^* \ \& \ \tau(s) \supseteq t^* \ \& \ \text{Exp}(s, D.) \ \& \ \text{believe}(s) \ \& \ \forall w' \in \text{CON}(s): \text{it is raining at } \tau(s) \text{ in } w']$
 where $\text{CON}(s) = \cap \wp$ where $\wp = \{p \mid p \text{ is a belief of the experiencer of } s \text{ at } \tau(s)\}$ ⁶⁴
‘There is a state s in w whose running time overlaps t*, which is a belief state by Darcy, s.t., all worlds compatible with the content of s (=Darcy’s beliefs) are rain-worlds’.*

We now have the formal tools to reformulate our epistemic accessibility relation, which, as you recall, was supposed to pick out worlds compatible with the *beliefs* of the speaker, in terms of events. This epistemic relation will pick out worlds compatible with the CONTENT of a particular belief state. This state/event argument, is what will need to be bound, and will only allow binders that can provide content:

(210) $f_{\text{EPISTEMIC}}(s) = \lambda s. \lambda w. w \in \text{CON}(s)$

We thus have an epistemic relation for modals that require a binding event which has CONTENT. We also assume that attitudes have a CONTENT state, and that, furthermore, they can bind free

⁶³ This idea started from a suggestion by Irene Heim (p.c.).

⁶⁴ I am here abstracting away from the difficult intricacies involved with *de se* ascriptions with attitudes mentioned earlier. One potential issue with the current proposal is whether these *de se* readings warrant the postulation of an extra *de se* state *s'* argument for the attitude (P. Anand, p.c.). My hope is that a more precise account of what sort of propositions make up CON(s) might suffice. I leave this question open for future research.

event variables in their scope (the way they were taken to bind individuals, times and worlds in e.g., von Stechow (2002)). Thus, an attitude will naturally bind the event variable of a modal's epistemic accessibility relation in its scope, as illustrated below:

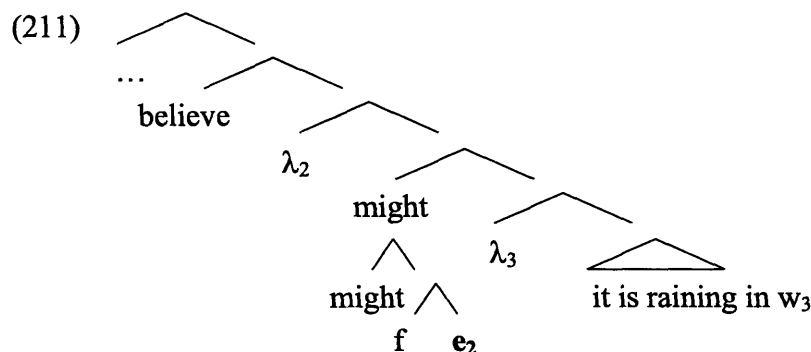

b. Darcy believes that it might be raining.

$$\exists s[s \text{ in } w^* \ \& \ \tau(s) \supseteq t^* \ \& \ \text{Exp}(s,D.) \ \& \ \text{believe}(s) \ \& \ \forall w' \in \text{CON}(s): \exists w'' \in \text{CON}(s): \text{it is raining at } \tau(s) \text{ in } w'']]$$

Notice that for both attitudes and the epistemic relation, the set of worlds is in function of a belief state, and not a world; furthermore, when an epistemic modal is bound by an attitude verb, as is the case above, the *same* belief state is used for both accessibility relations. This has an interesting consequence: observe that the universal quantifier in (b) is not binding anything. This was different, when there was no modal, as in (209) above, where the proposition ‘*that it rains*’ held in all of the worlds w' compatible with Darcy’s belief state. Here, the quantification is vacuous: The LF in (211)b) is equivalent to:

$$(212) \ \exists s[s \text{ in } w^* \ \& \ \tau(s) \supseteq t^* \ \& \ \text{Exp}(s,D.) \ \& \ \text{believe}(s) \ \& \ \exists w'' \in \text{CON}(s): \text{it is raining at } \tau(s) \text{ in } w'']]$$

Thus, stating the attitude’s accessibility relation in terms of states/events rather than worlds gives rise to a layer of vacuous quantification over the subject’s belief-worlds, in cases where we have an epistemic under an attitude like *believe*. This, I take to be a welcome result, given the similarity of meanings in the following pairs of examples. The sentence in ((213)a) is basically equivalent to that in (213)b):

- (213) a. Darcy believes that it might be raining.
 b. It might be raining according to Darcy.

Moreover, the sentence in ((214)a), where the subject (i.e., the experiencer of the *believe* state) is the speaker ('I'), is not only truth conditionally equivalent to that in ((214)b), it also sounds redundant:

- (214) a. ?I believe it might be raining.
b. It might be raining.

Thus, the advantage of having the attitude be relativized to a state, rather than a world is that we derive the equivalence facts in (213) and (214) without having to postulate two separate entries for when the embedded complement has an epistemic modal in it, and for when it doesn't. This is only, at this point, a matter of aesthetic preferences. My argument is simply that this vacuous quantification might actually be an advantage, rather than an eyesore. In an event-free approach, (211) would have the attitude quantify over epistemically accessible worlds w' , such that there is a world w'' epistemically accessible from w' in which the complement holds. This would yield the correct meaning, but would require further assumptions about the believer not having false or unjustified beliefs (see Stephenson 2006 for such an implementation).

The main semantic contribution of attitudes, then, will be to introduce a special attitude state (i.e., a state with CONTENT), and attribute it to an individual: its experiencer. Attitudes have various meanings: what one hopes for or what one believes will have different contents. However, the unifying trait of all attitudes will be that they take a special eventuality argument, namely one that has CONTENT. The only innovation from a standard Hintikka-style account, will be to anchor the attitude in time and space via a state or an event (in a Davidsonian sense), which it will also relate to its holder via an experiencer of *s* relation. This attitude state will be linked to its content (a set of propositions) via the CON(*s*) relation. Hence, I take it that all attitudes are verbs (predicates of events) which have a selectional restriction that forces them to combine with an eventuality argument which has CONTENT.

The case of the predicate *say* is a bit more delicate. First, *say* is more of an event than a state. We could, however, assume that an event can also have content. The question becomes what is the CONTENT of an event of saying. There seem to be two ways to go. The first is to assume that 'saying' means expressing a belief, or voicing a thought out loud. If, for instance, I say '*Jane is in Paris*', but the proposition 'that Jane is in Paris' is not compatible with my beliefs

(e.g., ‘that Jane is not in Europe’ is one of my beliefs), then I will have lied. Thus, *saying* just like *believing* will have content, and this content will be a set of propositions, namely those that the ‘sayer’ believes to be true in the actual world:⁶⁵

(215) Darcy said that it might rain.

$$\exists e[e \text{ in } w^* \ \& \ \tau(e) \subseteq t \ \{t < t^*\} \ \& \ \text{Ag}(e, D.) \ \& \ \text{say}(e) \ \& \\ \forall w' \in \text{CON}(e): \exists w'' \in \text{CON}(e): \text{it is raining in } w'']$$

However, there seems to be another, perhaps more salient reading of ‘say’. We sometimes only ‘say’ one thing. Thus, in (215), the CONTENT of what Darcy said will be the proposition ‘that it might rain’. In a standard Hintikka-style semantics we would analyze (215) as ‘*In all worlds compatible with what Darcy said, it might rain*’. In this case, the set of accessible worlds will be those compatible with the proposition ‘*it might rain*’, and all of the propositions that entail it. Thus, for instance, the sentence ‘*Darcy said that someone left out the trash*’ will be judged true if Darcy’s actual utterance was ‘*Jane left out the trash*’, since ‘*Jane left out the trash*’ entails ‘*someone left out the trash*’: ‘in all worlds compatible with what Darcy said, the proposition ‘someone took out the trash’ is true. Switching to our notion of CONTENT will simply add ‘compatible with the CONTENT of what Darcy said’ and, here as well, we will be quantifying over worlds in which the proposition ‘*it might rain*’ is entailed.

4.2.1.2. *Speech Event*

We just saw that attitudes provide an eventuality which can bind the eventuality argument of a modal under it. What happens in cases where there is no attitude? I propose that the speech event will take on a similar role. For this, I rely on the assumption that in matrix contexts, we have a speech act projection syntactically represented (cf. Rizzi (1997), Ambar (1999, 2001), Cinque (1999), Tenny and Speas (2004), a.o.). The speech event will be able to bind the event argument of a modal’s accessibility relation. In order to do so, however, it will have to be an event of the right type, that is, an event with content.

This is where things get a bit more murky. First of all, this syntactic representation of the speech event is not widely accepted. The idea first originated with Ross (1970)’s Performative

⁶⁵ I am simplifying the LF somewhat: for instance the Tense involved would presumably be a present on top of a CF, on top of a Perf, which can thus capture the future orientation of the complement clause. See the Appendix of Chapter 2.

Hypothesis (cf. also Sadock 1974). Ross (1970) proposes a speech act phrase as the highest clause with the template below, where the performative verb can be *declare, state, order, etc...*:

(216) I V_{performative} you S'

Such a representation could handle effortlessly the puzzling presence of anaphors (e.g., *yourself*) in (a) below, or the presence of adverbials (e.g., *frankly*) that seem to modify a *telling* event:

(217) a. (I say to you that) People like yourself are rare. [Ross (1970)]
 b. (I tell you) Frankly, I prefer the white meat.

Many syntactic and semantic issues have since been brought up (for a review, see Levinson 1983), such that, no one believes the strong version of the performative hypothesis anymore. To mention just one, the pair of sentences should have the same truth conditions:

(218) a. I state to you that the Earth is flat. [Levinson (1983)]
 b. The Earth is flat.

While ((218)a) is true automatically by virtue of me uttering it, ((48)b) isn't. However, according to the Performative hypothesis, there is a covert 'I state to you that' in ((48)b), such that there shouldn't be a meaning difference between ((48)a) and ((48)b).

Some versions of the performative hypothesis have been revived lately, which try to go around the problems that Ross faced. Tenny and Speas (2004) assume, for instance, a syntactic Speech Act phrase, which encodes the illocutionary force of a sentence. They show that, cross-linguistically, only four types of speech acts are grammaticalized: Declaratives, Interrogatives, Imperatives and Quotatives, and thus they constrain the system to these four types. The following structure illustrates the speech act phrase for a declarative:

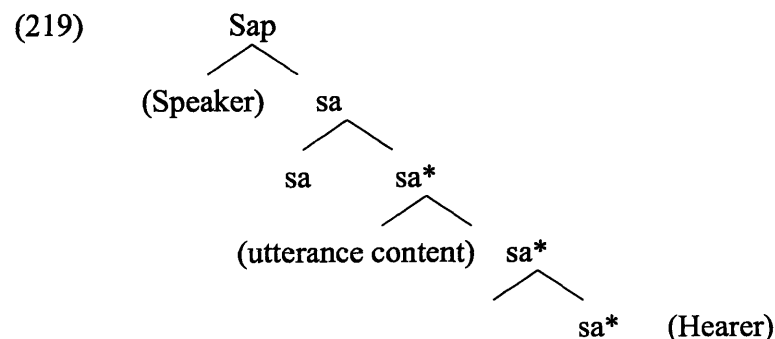

In this structure, the speaker is the agent of the speech act, the utterance content, its object, and the hearer, its goal. According to Tenny and Speas, their Speech Act Phrase (SAP) avoids Ross's problems, as every sentence has one and only one SAP which gives no specific information about whether the speech act is a *telling*, a *warning*, or a *report*. Thus, the pairs in (218) have different representations:

- (220) a. [_{SAP} [SPEECH ACT [_{CP} I state to you that the Earth is flat]]]
 b. [_{SAP} [SPEECH ACT [_{CP} The Earth is flat]]]

Assuming then that such an abstract speech act phrase is the top projection in the matrix, and that it can bind free event arguments, the speech event will have to provide an eventuality of the right type, that is, one that has content. What is the content of this speech event?

- (221) Jane might be home.
 SPEECH ACT(e): $\exists w' \in \text{CON}(e): \exists e' [e' \text{ in } w' \ \& \ \text{be home}(e', w', J)]$

We expect that it should have some common traits with the predicate *say*. After all, a declarative speech act is an act of *saying*. However, intuitively, (221) doesn't mean that '*there is a world compatible with the content of what I say where she is home*'. The speaker is not making a claim about his own speech act. Rather, (221) seems to report an epistemic possibility, for the speaker, that it, '*there is a world compatible with the content of my beliefs where she is home*'. Thus, the speech event appears to be more like the 'express a thought' meaning of 'say': '*there is a world compatible with the content of my beliefs in which Jane is at home*'. Is this cheating? Not really. It is important to bear in mind that, while a declarative speech event will show a family resemblance with the predicate *say*, it shouldn't be constrained to its exact meaning (besides, 'say' does have such an 'express the belief that p' meaning). Assuming that speech events share the exact same meaning as those predicates that express types of speech acts (e.g., *declare...*) is precisely what doomed the original Performative Hypothesis. Instead, as Tenny and Speas (2004) emphasize, we want this speech act to be abstract, where what gets grammaticized is essentially the illocutionary force.

While I shy away from giving a precise syntax and semantics of this speech act projection, I propose that the following three assumptions from Tenny and Speas and the additional one about event CONTENT can derive the correct meaning for epistemic modals in matrix context:

1. Every sentence has a (single) speech act projection, where the speech event sits.
2. There are only four types of speech acts: Declaratives, Interrogatives, Imperatives, and Quotatives.
3. The primary role of the speech event is to provide the illocutionary force of the sentence and to represent syntactically the participants of the event, and their relation to the speech event.
4. A speech event e^* has CONTENT. This CONTENT varies based on the type of speech act: In a Declarative, the content of e^* will be the beliefs of the speaker. In an Imperative, the content will be the To-Do List of the Addressee, that is, the list of propositions that the Addressee has to bring about (cf. Portner 2001). (We will return to To-Do Lists in section 4.2.3)⁶⁶.

Thus, we have a default speech event e^* at the topmost position, which can bind free event variables in its scope (per Percus' (2000) default world binder). Its CONTENT will be the beliefs of the speaker when the sentence is declarative. Because the terminology might be a bit confusing, I would like to stress that when I talk about the content of the speech event, I do not mean what the speaker said, I am not referring to the proposition being expressed but rather to the **attitude content** of the speaker, i.e. his beliefs. We obtain the following:

(222) Jane might be home.

SPEECH ACT_{DECLARATIVE} (e^*): $\exists w' \in \text{CON}(e^*): \exists e'[e' \text{ in } w' \ \& \ \text{be home}(e', w', J)]$
 '[declarative:)] *In some world compatible with the content of my [the speaker of e^*] beliefs Jane is home.'*

⁶⁶ Tenny and Speas argue that every sentence has a Point of View/Seat of Knowledge, that is, 'a sentient mind, who can evaluate, process, or comment on the truth of the proposition'. In a declarative, it is the speaker; in an imperative, the hearer. To derive this mapping, they propose, following Cinque (1999), that below the SAP, there is an Evaluation Phrase which carries a seat of Knowledge argument. This argument gets bound by the speaker or the hearer depending on the way they project, which is contingent on the type of speech act (e.g., in an interrogative, the hearer gets promoted and becomes the evaluator). While this projection is also supposed to handle issues beyond the scope of this dissertation such as logophoricity, I simply suggest, that, for the data at hand, giving each speech event a CONTENT captures this 'Point of View', without having to resort to an extra syntactic Evaluation Phrase projection.

What happens without an epistemic modal? In cases where the speech event doesn't bind anything, we will obtain a run of the mill meaning for a declarative sentence. While the speech event provides the illocutionary force of the sentence and syntactically represents its participants, its (attitude) CONTENT won't directly be computed in the meaning of the sentence which doesn't appeal directly to it (the speech event doesn't bind any free event variable):

- (223) Jane is home.
 SPEECH ACT_{DECLARATIVE} (e*): $\exists e'[e' \text{ in } w' \ \& \ \text{be home}(e', w', J)]$
 '[declarative:] *Jane is home.*'

Thus, the above sentence will be understood as more of a declarative statement ('*I am telling you that Jane is home*') than a belief report ('*I believe Jane is home*').

4.2.2. Circumstantial accessibility relation

What about a circumstantial accessibility relation? What worlds are being quantified over in the following modal statements?

- (224) a. Hydrangeas can grow here.
 b. Jane can lift this table.
 c. Jane can take the train to go to Paris.

The commonality between the sentences in (a)-(c) is that we are talking about a possibility of an event happening, *given* certain facts about the world. In (a), these facts include the type of soil/climate that hydrangeas require to grow, and properties of the soil/climate *here*. In (b), the relevant facts are Jane's physical shape, properties of the table, the law of gravity, etc... In (c), the possibility of an event of Jane taking the train is contingent on the train schedule, Jane's own schedule, etc. In brief, these modals require us to take into consideration the circumstances under which the complement event is to take place.

Portner (1998) proposes some event property-relativity in his analysis of the progressive. As we saw in chapter 2, Portner takes the modal element of the progressive to consist of a circumstantial modal base, $\text{Circ}(e,P)$ which 'contains the relevant circumstances *in e*, in particular Max's and the street's physical condition' (p774) in '*Max was crossing the street*'. Such circumstances, he argues, include propositions such as 'Max is in good physical condition, Max intends to cross the street, Max is not drunk and can walk straight, etc...'. Portner further

claims that we cannot come up with ‘a precise algorithm for determining the correct modal base for a given progressive sentence, any more than we can for sentences containing ordinary modal verbs’. While I agree with Portner that we have a certain amount of vagueness and context dependence in determining which circumstance of the event is relevant, we still find some recurring factors among all circumstantials regarding which facts need to be taken into account. Some facts will always be factored in, namely, the (physical) properties of the event’s participants, the location and the time of the event. From the preconditions/presuppositions associated with the main predicate we will then infer *which* of these properties are ‘*relevant*’. In (224)a we take into account (physical) properties of the kind *hydrangeas* as well as properties of the location *here*, relevant to an event of growing. Thus the *color* of hydrangeas might be less relevant than the amount of water they require to grow, but it won’t matter much. In (224)b we take into account (physical) properties of Jane as well as that of the table, again, relevant to a lifting event. Here Jane’s strength or the table weight will be relevant. In (224)c we take into account properties of Jane as well as that of the train, relevant for a taking the train event: here physical strength won’t matter much, but Jane’s location w.r.t. e.g., a train station will matter. Thus, it seems that while all circumstantials select the same type of accessibility relation, the relevance of which properties of the event’s participants is contingent on the event itself. We will get more of an ability reading when the relevant properties are that of the subject, and more of a pure circumstantial or goal-oriented reading when the relevant properties are that of the location and time. Thus, the set of facts traditionally used for a circumstantial modal base in (a) can be recast in event terms as in (b):

- (225) a. $\wp = \{ p \mid p \text{ is a relevant fact in } w \}$
 = {that J. is strong; that the table weighs 50lbs; that the table is empty...}
- b. $\wp = \{ p \mid p \text{ is circumstance of } e \}$
 = {that Ag(e) is strong, that Th(e) is 50lbs, that Loc(e) subject to gravity...}

I thus propose the following circumstantial accessibility relation:

(226) $f_{\text{CIRC}}(e) = \lambda e. \lambda w. w \text{ is compatible with the circumstances of } e = \lambda e. \lambda w. w \in \text{CIRC}(e)$

The following example illustrates a case of a circumstantial accessibility relation on a ‘low’ modal, where the accessibility relation’s event argument is bound by Perfective Aspect:

(227) a. Jane a pu courir
Jane could-pfv run

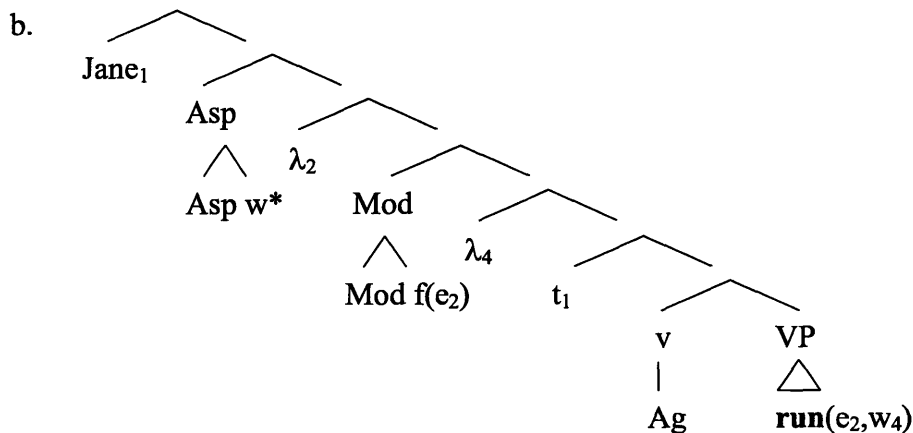

c. $\exists e[e \text{ in } w \ \& \ \tau(e) \subseteq t \ \& \ \exists w' \in \text{CIRC}(e): \text{run}(e, w') \ \& \ \text{Ag}(e, J).$

d. There is an actual past event e such that in some world compatible with the relevant circumstances of e , e is a running event by Jane.

The aspect's world variable gets bound by the matrix binder, yielding an actual event. The modal's event variable gets bound by aspect. Note in passing that, given that aspect quantifies over a plain event (i.e., without content), the only compatible accessibility relation is a circumstantial one (as opposed to the epistemic): *Some event e happened, which in some world compatible with the circumstances of e (Jane's actual physical properties, her location, the weather, etc...) was a running event.* We will thus infer that Jane actually ran and that it was in accordance with her physical properties at the time of the running.

4.2.3. Deontics

In chapter 1, we made a distinction between true deontics, that is, those that put an obligation on the addressee, and subject-oriented deontics, which were assimilated to cases of goal-oriented modality. I proposed that the latter are essentially root modals: aspect can raise and bind the event argument of the accessibility relation, relativizing the modality to the subject (the agent of the event) and yielding a circumstantial modal base. True deontics, on the other hand, are tied to the speech event, and keyed to the addressee.

How can the modality be relativized to the addressee and what type of accessibility relation is involved? I will build my proposal on that of Ninan (2005) for English deontic *must*⁶⁷. Ninan (2005) tackles the difference between pairs of sentences, such as the ones below:

- (228) a. #Lydia must go to confession, but she won't.
b. Lydia should go to confession, but she won't.

He proposes that (a) is bad for the same reasons that the following sentences are bad:

- (229) a. #Go to confession, but you won't.
b. #I promise to go to confession, but I won't.

Building on Portner (2001)'s theory of imperatives, Ninan argues that deontic *must* puts the proposition expressed by its complement on someone's TO-DO LIST. TO-DO LISTS are sets of propositions, and each participant of the conversation has one. A requirement, then, is putting something on someone's TO-DO LIST. The reason why the above examples are bad is that, in order to put something on someone's TO-DO LIST, the speaker must believe that there is a possibility that that person will do it. Otherwise, the speaker shouldn't bother. The sentences in (228)a) and (229)a) are bad because their continuation denies such an epistemic possibility. Ninan argues that *must p* both puts *p* on someone's TO-DO LIST and adds a proposition to the common ground, namely that the subject has the obligation to do *p*.

For Ninan, this To-Do list feature is somehow associated with *must* but not *should*, which is why (228)b) is good. To recast slightly Ninan's proposal in my terms, I would like to say that English *must* can only have a Sp/A-O interpretation, whereas *should* can be Su-O (with a goal-oriented interpretation). This requirement could be captured via some selectional restriction on the type of accessibility relation that this modal takes, as is often assumed for the requirement that English *might* can only have an epistemic interpretation (cf. Kratzer 1981).

Recall that true deontic interpretations cannot be interpreted in the past. The following example with *devoir* cannot be used when the speaker is addressing the babysitter, the same way a true Sp/A-O modal as in ((59)b) is infelicitous. (With a goal-oriented interpretation ((51)a) is fine and yields an actuality entailment):

⁶⁷ Ninan's claim is about English *must*, not all universal modals; *have to*, for instance is fine. Note that there is some speaker variation in acceptance of (228)a): for some English speakers, the sentence is fine.

- (230) a. ??Kitty a dû faire ses devoirs, (mais elle ne les a pas fait/et elle les a fait).
 Kitty must-pfv do her homework, (but she didn't do it/and she did it.)
 b. ??Kitty a été censée/supposée faire ses devoirs, ^{ok}mais elle ne les a pas fait.
 Kitty was-pfv supposed to do her homework, but she didn't do it

I follow Ninan, in assuming that the reason why the above sentences are bad is that, when the speaker puts an obligation on the addressee, he cannot do so about a past state of affairs: it is impossible for anyone to bring about a *past* state of affairs.

How can we formalize Ninan's insight and adapt it to the current proposal? Recall that the main claim of this chapter is that accessibility relations have an event variable which needs to be bound. I thus propose a third accessibility relation to our stack:

(231) $f_{\text{DEONTIC}}(e) = \lambda e.\lambda w. w$ is compatible with the Addressee of e 's TO-DO LIST

Note that, as with the epistemic relation, we have some selectional restriction on the type of event that can bind the event argument of the deontic relation. Namely, the event has to have an addressee. In matrix context, this will straightforwardly be the addressee of the speech event.

Can we get embedded cases? Predicates that report a performative speech act should be fine, and indeed the following sentence seems acceptable (K. von Stechow, p.c.):

- (232) Jane said that Lydia must go to confession.
 $\exists e [e \text{ in } w^* \ \& \ \tau(e) \subseteq t \ \{t < t^*\} \ \& \ \text{say}(e) \ \& \ \text{Ag}(e, J.)$
 $\ \& \ \forall w' \in \cap(\text{TO-DO LIST}(\text{ADDR.}(e))): \text{Lydia goes to confession in } w'$
'There is a past saying event by Jane s.t. in all worlds compatible with the requests on her addressee's, Lydia goes to confession'

Jane put the proposition *Lydia goes to confession* on her addressee's TO-DO LIST. While the performative act itself is lost, the report of that past performative act remains.

Kratzer (1981) points out an interesting contrast between the two German necessity modals *sollen* and *müssen*. Consider the following example:

- (233) a. Ich muss ein Bäcker werden.
 b. Ich soll ein Bäcker werden.
 I must become a baker.

While (a) is compatible with the obligation being put on me by someone else, *sollen* requires that the obligation comes from within (it cannot be my mother's wishes rather than mine). We can capture this fact via an accessibility relation which will pick out worlds compatible with the speaker's To-Do list, mimicking Portner's (2001) treatment of 'promise':

(234) $f_{\text{DEONTIC2}}(e) = \lambda e.\lambda w. w$ is compatible with TO-DO LIST(SPKR(e)).

4.3. RESTRICTIONS ON THE TYPE OF ACCESSIBILITY RELATIONS.

Let's sum up. We have three accessibility relations:

- (235) a. $f_{\text{EPISTEMIC}}(e) = \lambda e.\lambda w. w$ is compatible with CON(e)
 b. $f_{\text{CIRC}}(e) = \lambda e.\lambda w. w$ is compatible with CIRC(e)
 c. $f_{\text{DEONTIC}}(e) = \lambda e.\lambda w. w$ is compatible with TO-DO LIST(ADDR(e)).

We also have three possible binders: the speech event, attitude verbs, and aspect. As we saw in section 1, not all combinations of binders and accessibility relations are possible. In general, epistemic relations are reserved for speaker/attitude oriented modal, that is, modals which are merged above Tense. Deontics are reserved for addressee-oriented, and circumstantials for subject-oriented, that is, modals merged below Tense. Does our system capture these restrictions naturally?

4.3.1. Restrictions on a deontic accessibility relation

We already saw that a deontic accessibility relation will only be available when the binding event has an addressee (who has a TO-DO LIST). Note, for instance, that cases of embedding which do not report a performative act are odd (and maybe even ungrammatical with *hope*):

(236) Jane [?]believes/^{??}hopes that Lydia must go to confession.

If we try to interpret the embedded *must* as a deontic, we get a sense that, Jane put it on her own TO-DO-LIST to make sure that Lydia goes to confession (*must* with an epistemic interpretation is, of course, fine). Thus, a deontic will only appear in the following configurations:

- (237) a. sa λ_1 ATT Addr. λ_2 Mod e_2 T Asp λ_3 V e_3
 b. sa λ_1 Mod e_1 T Asp λ_3 V e_3

4.3.2. Restrictions on a circumstantial accessibility relation

What about a circumstantial accessibility relation? In general, this accessibility relation is very natural for ‘low’ modals. We saw an example in section 4.2.2., which involved perfective aspect, moving above the modal and binding the event argument of its accessibility relation. Here is another example, with imperfective morphology, which, in this case, I take to signal a generic operator (cf. chapter 2):

(238) a. Jane pouvait courir.
Jane could-impf run

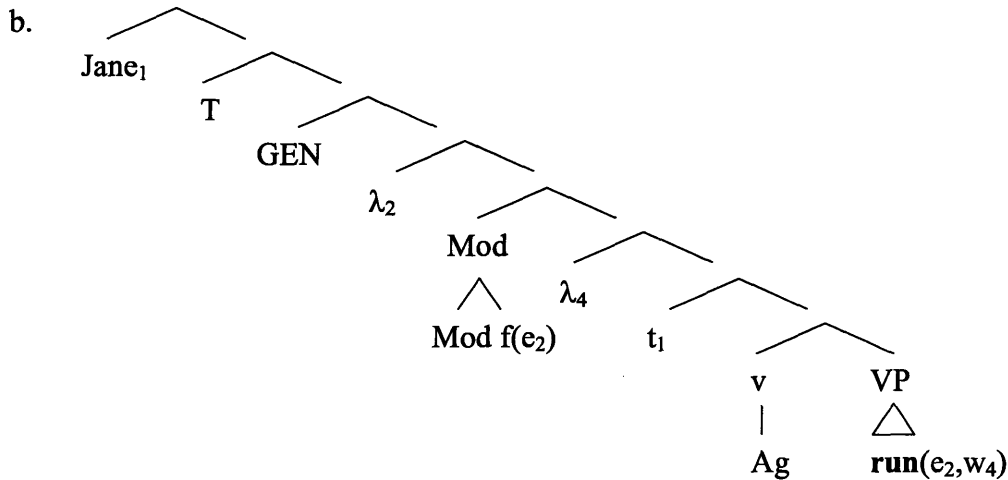

c. $\forall e_2 \in f_{\text{nor}}(t, w): \text{precond.-for-J.'s-run-hold}(e_2): \exists w_4 \in \cap \text{CIRC}(e_2): \text{run}(e_2, w_4) \ \& \ \text{Ag}(e_2, J.)$

d. All normal events e_2 from the perspective of w at past time t , where the preconditions for running by Jane hold, are such that there is world compatible with e_2 's circumstances (i.e., properties of its agent Jane in w relevant for running: strength, stamina...), where e_2 is a running event by Jane.

Note, in passing, that this derivation doesn't yield an *actual* event at time t : the sentence simply states that all *normal* events where the preconditions hold are running events in some world compatible with Jane's properties, her surroundings, etc.

Let's look at another example, involving a 'pure' circumstantial:

(239) It can rain hard here.

$\forall e_2 \in f_{\text{nor}}(t, w): \text{precond.-for-rain}(e_2): \exists w_4 \in \cap \text{CIRC}(e_2): \text{rain}(e_2, w_4) \ \& \ \text{Loc}(e_2, \text{here})$

All normal events e_2 from the perspective of w at past time t , where the preconditions for raining hold, are such that there is world compatible with e_2 's circumstances (i.e., properties of the location here...), where e_2 is a raining event at here.

I take this example to involve a Generic Operator on top of a low modal, which binds the event argument of the modal. The worlds selected will be those in which certain circumstances of the location hold, which are relevant for raining: humidity, pressure, body of water, surrounding mountains...

Recall from chapter 2 that we cannot have progressive aspect scope over the modal (for arguments why the imperfective in these examples has to be progressive aspect, see chapter 2):

- (240) a. Il ouvrait la porte quand la clé a cassé. [I. Heim, p.c.]
 He opened-imp the door when the key broke
 ‘He was opening the door when the key broke’
 b. #Il pouvait ouvrir la porte quand la clé a cassé.
 He could-imp open the door when the key broke

If Progressive is unable to move above the modal, then the only possible configuration of a modal and progressive will be as follows:

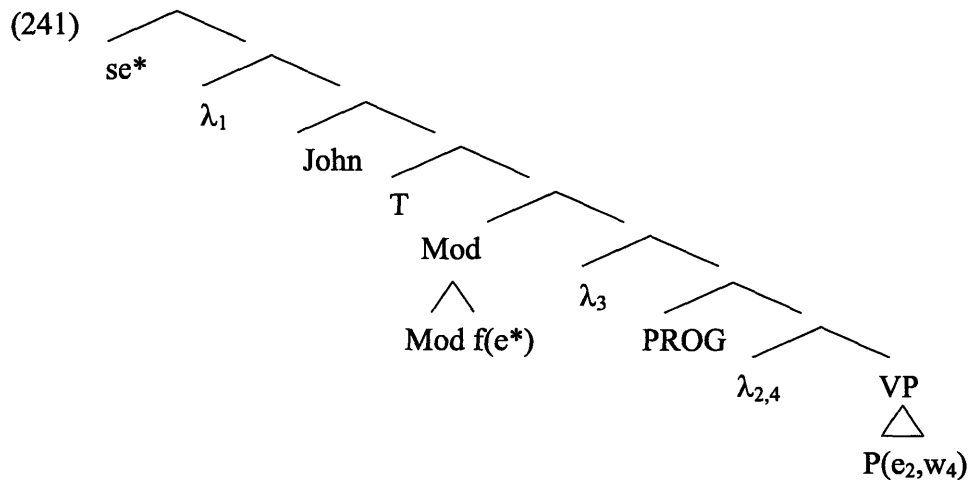

Interestingly, when we have a progressive in the complement, the modal’s interpretation strongly favors an epistemic relation:

- (242) a. A l’heure du crime, Jane pouvait être en train de lire un livre.
 At the time of the crime, Jane could-imp be reading a book.
 b. A l’heure du crime, Jean devait lire un livre.
 At the time of the crime, Jane must-impf read a book.
 ‘At the time of the crime, it must be the case that Jane was reading a book’.

If Progressive cannot move past the modal, then the only binding option for the eventuality argument of the modal is to be bound by the speech act binder. And, in these cases, we seem to get an epistemic relation.

Now, couldn't a 'high' (speech act bound) modal have a circumstantial accessibility relation? Nothing, in principle rules out such a combination. However, the resulting meaning would be odd:

(243) Jane must escape.

[Se* [must f_{CIRC}(e*) [Asp₂ [Jane escape (e₂)]]]]

'In all worlds compatible with the circumstances of the speech event (properties of the speaker at t relevant for the speech event), Jane escapes'*

It is difficult to make sense of what (243) should mean with such a speech event bound circumstantial relation. The other examples of circumstantial modality all seemed to involve physical properties of the event participants. It is not clear which physical properties would be 'relevant' for a speech event. We could start to include more mental properties relevant for making a speech event (e.g., how informative the speaker is), but then, the relation starts looking more and more like an epistemic one.

Thus, it seems that a circumstantial accessibility relation is dispreferred when bound by the speech event, in favor of an epistemic one, or perhaps, that it morphs into an epistemic one. In our progressive case, given that, for some reason, the progressive cannot move above a root modal, the modal has to be bound by the speech event, and hence gets an epistemic relation.

I would like to close off this section by turning to cases where a circumstantial accessibility relation is dispreferred, namely those involving a stative complement. In that case, our preferred interpretation of the modality is a speech bound epistemic relation. Why should this be? Hackl (1998) shows that ability ascriptions require a change-denoting complement. Thus, if the complement of an ability modal is a stage-level predicate, it gets coerced into an inchoative meaning, as in (244)a) below, which we understand to mean that Jane can *get* sick (we have a change of state from a non sick to sick state). An individual-level predicate as in (244)b) will simply be ungrammatical (one cannot change in and out of states like *having blue eyes*):

- (244) a. Jane can be sick.
 b. *Jane can have blue eyes.

Note that it is a quirk of English *can* that it cannot have an epistemic meaning (the same way *must* can only be epistemic or truly deontic). Thus, given that we cannot interpret (b) as an epistemic nor as a circumstantial, the sentence is ungrammatical. The French translation of (244)b) with *pouvoir* is out with an ability reading but fine with a (speech event bound) epistemic.

Hackl (1998) suggests that this ban against non change-denoting complements of ability modals results from an incompatibility with the facts that make up the circumstantial modal base. Take our infelicitous (244)b). The accessibility relation will have in it properties of Jane, which are relevant for having blue eyes. What could such properties be? They will have to do with a particular genetic make up. But then, Jane should have the same genetic makeup in all of the worlds circumstantially accessible, that is, all of the worlds where her genetic makeup holds. However, using an existential modal invites the inference that, if there is a world among a set where P is true, there also should be a world among this set where P is not true. But if Jane has the same blue eye gene in all of these worlds, how could there be one where she doesn't have blue eyes?⁶⁸

Given the ban against non change of state denoting complements for existential circumstantials, in the sentence in (245)a) a *circumstantial* accessibility relation is dispreferred (unless we coerce the complement into an inchoative). Furthermore, an *aspect-bound epistemic*

⁶⁸Note that all circumstantial possibility modals should also obey Hackl's ban against non change denoting complements for the same reasons. What about universals? Nissenbaum (2005) shows a contrast between possibility and necessity goal-oriented modals:

- (i) a. *You can know French to work in the public schools.
 b. You have to know French to work in the public schools.

Unlike an existential, a universal won't trigger an inference that there is a world in which all of the subject's relevant properties hold (in particular, her blue-eye gene), and where she doesn't get blue eye. Accordingly, the following sentence is fine:

- (ii) Jane had to have blue eyes. (It was in her genes.)

Moreover, with a universal, the circumstantial accessibility relation further provides a sort of explanation for Jane having blue eyes: *given* her genetic make up, there was no possibility for her not to have blue eyes: all of the worlds where she has that make-up are blue-eyes worlds. Note that, while the sentence is fine, it still receives an inchoative meaning (i.e., *Jane got blue eyes*). We may thus need to refine our circumstantial accessibility relation and make it pick out worlds compatible with the circumstances *pre-e*.

relation will be impossible in this case: there is no state/event of the right ‘content’ type. Thus, we prefer to interpret this as a *speech event* bound *epistemic*, as illustrated in ((75)b):

- (245) a. Jane a pu être malade.
 Jane could-pst-pfv be sick
 ‘*It is possible that Jane was sick.*’
 b. $se^* \text{ Mod } f_{\text{EPIS}}(e^*) \text{ T Asp VP}$

To sum up, a circumstantial accessibility relation is fine when its event argument is bound by aspect (so long as the complement denotes a change of state). When it is bound by the speech event, the meaning starts to become incoherent: when we try to accommodate a circumstantial interpretation, its meaning gets blurred with a true epistemic interpretation.

4.3.3. Constraints on the epistemic relation

We saw that an epistemic relation requires a binder that can provide an event with CONTENT. As we saw, this is done naturally by attitudes and the speech act. Could a ‘low’ modal get an epistemic accessibility relation? In most cases, no. In the sentence below the event provided by Aspect doesn’t have CONTENT, hence an epistemic accessibility relation is unavailable:

- (246) Jane could lift this table.
 # $\exists e [e \text{ in } w^* \ \& \ \tau(e) \subseteq t \{t \langle t^* \rangle \} \ \& \ \exists w' \in \text{CON}(e): \text{Jane lift this table.}]$

What if, however, we have an attitude verb in the complement?

- (247) a. Jane might consider Darcy smart. [K. von Fintel, p.c.]
 b. Jane a pu penser que Darcy aimait Lizzie.
 Jane could-pfv think that Darcy loved Lizzie
 ‘*Jane might have thought that Darcy loved Lizzie.*’

The most natural interpretation of the modals in ((247)a) and ((71)b) is epistemic, where the epistemic state is that of the *speaker*. We can generate this meaning by having an LF where the modal is merged above Tense (as in ((248)a) below). Its event argument gets bound by the speech event, and is thus relativized to the *speaker’s* beliefs. However, another LF can get generated. If the modal is merged below Tense (as in ((248)c) below), Aspect will move up. Because the event bound by Aspect has CONTENT (*think*), it can then bind the eventuality of the

modal, and thereby generate an epistemic relation. And because the modal is bound by aspect, the modal should report the epistemic state of its experiencer, the *subject*:

- (248) a. [SA(s*) [Jane can_{s*} [T AspQ₂ [think (s₂) [Darcy... epis, Sp/A-O
 b. $\exists w \in \cap \text{CON}(s^*): \exists s [\tau(s) \subseteq t \{t < t^*\} \& \text{think}(s) \& \forall w' \in \cap \text{CON}(s): D. \text{loves } L.$
 c. [Jane T AspQ₂ [can_{s2} [think(s₂) [Darcy... ^{??}epis, Su-O
 d. $\exists s [\tau(s) \subseteq t \{t < t^*\} \& \exists w \in \cap \text{CON}(s): \forall w' \in \cap \text{CON}(s): \text{Darcy loves Lizzie in } w'$

Thus, if (c) gets generated, it will have the following meaning: *'There was a belief state s of Jane's such that, some world w compatible with the content of s is such that all worlds w' compatible with s are worlds where Darcy loves Lizzie'*. In other words, it could mean that there was an epistemic necessity for Jane that Darcy loves Lizzie. Could (247)b) have such a meaning? At first blush, it seems that it may not. The speech event bound version is clearly more salient.

Irene Heim (p.c.) points out, however, cases where such readings might, in fact, occur, especially with more eventive attitudes. She reports that, in the German example in ((249)a), the modal can be tied to the subject's 'epistemic state' at a past time. Here, the difference in meaning between an epistemic relation and a circumstantial one becomes murky: is it *'in some world compatible with the content of her beliefs'* or *'in some world compatible with the circumstances of her coming to believe'*? Interestingly, the sentences seem to be implicative: that is, we understand that Jane did notice that Darcy was nice in the actual world. This is of course a welcome result, if indeed, Aspect has moved the modal (and thus the modality is subject, rather than speaker-oriented).

- (249) a. Jane konnte sehen/merken/^{??}glauben, dass Darcy nett war.
'Jane could see/notice/believe that Darcy was nice'.
 [Jane AspQ₂ [can_{f(e2)} [see(e₂) [Darcy...
 b. Jane a pu remarquer que Darcy était gentil.
'Jane was able to notice that Darcy was nice'
 c. He was so tall that one could take him to be adult.
 [one AspQ₂ can_{f(e2)} [take (e₂)...]

To sum up, epistemic relations thrive on being bound by the speech event or an embedding attitude. It may also in rare occasions, be subject bound. However, most cases of aspect/subject bound modals involve an event argument which does not have content; in that case an epistemic relation will be ruled out.

4.4. TAKING STOCK OF SCOPE ISSUES – EPISTEMICS/DEONTICS VS. ROOTS

How does our account fare with the ‘height’ and scopal issues we discussed in section 2? We saw that Sp/A-O differed from S-O in several respects: first, epistemics tend to scope higher than negation, although that seemed to just be a preference⁶⁹. Epistemics/true deontics allow (and sometimes force) quantifiers to reconstruct under them, while with circumstantials, these quantifiers tend to be interpreted above the modals. In the same vein, while epistemics seem to preserve the idiomatic meaning of idiom chunks, a circumstantial modal seem to destroy it. Second, epistemics/true deontics are interpreted above tense; circumstantials below. Finally, epistemics are speaker/attitude holder-oriented, true deontics addressee-oriented, and circumstantials subject-oriented. We devoted most of section 4 to that last issue. What can we say about reconstruction? Recall Brennan’s example:

- (250) a. Every radio may get Chicago stations and no radio may get Chicago stations.
b. #Every radio can get Chicago stations and no radio can get Chicago stations.

The infelicity of (250)b) might fall out naturally. Consider the unmodalized version ‘*every radio station gets Chicago station*’: we are not dealing with a single event. Instead, we seem to have as many events of ‘getting Chicago stations’ as there are radios. To do so, all quantifiers will have to scope higher than the binder of the event (Aspect): Thus, *for all radios, there is an event...* Because in (250)b) aspect is above the modal, the quantifier, being above aspect, will be interpreted above the modal.

Idiom chunks may be a bit more involved. Why would a circumstantial relation destroy an idiomatic meaning? The answer may lie in a tug of war between the circumstantial accessibility relation wanting to pull out participants of the event, in order to provide properties

⁶⁹ A universal epistemic modal in French seems to always be interpreted above negation (a), a possibility epistemic modal on the other hand is interpreted below it. To express epistemic possibility, the negation needs to be below the modal:

- (i) a. Jane ne doit pas être chez elle.
‘Jane must [not be home].’
b. Jane ne peut pas être chez elle.
‘Jane cannot be home.’
c. Jane peut ne pas être chez elle.
‘It is possible that Jane is not home.’

These facts present an issue with the current proposal, if negation can only be merged in one position (right below tense). I leave this issue aside for future research

which can then determine whether the event takes place, and the idiom chunk not providing such clear cut participants. In the idiom *'the shit hit the fan'*, the shit is not the agent of the event, but instead seems to be an integral part of the event. When there is no obvious participant, based on whose properties the event will take place, as in (251)a), we might try to force the subject into an agent of the event, thereby destroying the idiomatic meaning. Interestingly, when we do provide a clear participant of the event, namely a location in (251)b), the sentence seems to retain its idiomatic meaning (I. Heim, pc.):

- (251) a. #The shit can hit the fan.
b. The shit can really hit the fan in this part of the world.

This suggests then, that the problem with (251)a), is not so much an issue of control vs. raising, but more the result of the circumstantial accessibility relation requiring well defined participants of the event, from which to extract properties contingent on which the event will take place.

As far as Tense is concerned, we saw that a modal could be merged above or below Tense. When it is merged above, its event argument gets bound by the speech (or attitude) event: we saw that, in these cases, we get an epistemic accessibility relation. Hence, we derive the fact that epistemics are interpreted above Tense. I now would like to briefly address von Fintel and Gilles (2006) counterexample, repeated below:

- (252) A : Why did you look in the drawer? [von Fintel and Gilles 2006]
B: My keys might have been in there. (=It was possible that my keys were in there)

Abusch (2006) presents a similar example: imagine that my partner and I bought a ranch, which had a good probability of containing a large oil reserve, and that this probability was confirmed by some testing. As it turns out, our tests were wrong, and the ranch only has salty water. I can then say:

- (253) We bought a ranch which might have contained an oil reserve.

Now both von Fintel and Gilles and Abusch argue that this cannot be a case of counterfactualty, as in Condorvadi's examples (cf. chapter 2). Recall that those involve a metaphysical modal base, which is done in terms of branching worlds. Worlds share a history up to a certain crucial

point and in some world, which branches off from the actual world, the complement takes place after that point (but not in the actual world). In the actual world, the keys/the oil reserve were never there: neither now, nor when I looked/ran the tests. Thus, if these worlds share a history, the keys were not in the drawer/the oil reserve was never there during the portion that the two worlds share, and hence in none of the metaphysically accessible worlds: the sentence should be false. von Fintel and Gilles conclude that we have a case here of an epistemic possibility *in the past*.

To handle such a reading then, we can assume an elided embedding attitude, itself set in the past (cf. Stephenson (2006)). Both of these contexts talk about a past time when they *believed* that there was a possibility for the oil reserve/the keys being there. Thus, while the possibility doesn't hold anymore, it did overlap with the internal *now* of the (past) thought:

- (254) a. ~~I thought that~~ my keys might be in there.
b. We bought a ranch which ~~we thought~~ might have contained an oil reserve.

I believe, then, that these examples can be assimilated to cases of sequence of tense Past, and as such won't affect the generalization that epistemics are interpreted above Tense. What underlies this generalization is that a modal with an epistemic accessibility relation can only be a modal which initially was merged above Tense. Because it was merged above Tense, its event argument has to be bound by the speech event or an embedding attitude, and the modality cannot be interpreted in the past.

4.5. INTERACTION OF TENSE, MODALS AND COUNTERFACTUALITY

In chapter 2, I argued for treating counterfactuality as involving a primitive CF modal, usually spelled out as *conditionnel* in French (or as *imparfait* under certain morphological conditions). I took this modal to be a universal quantifier over metaphysical worlds which further introduces an open time interval in which its complement takes place.⁷⁰ This meant that, in the presence of an overt modal, that overt modal did not carry the metaphysical meaning, but rather had to be interpreted above or below. I would like to close off this chapter by showing that while this claim might be controversial, it fits nicely with the picture proposed in this chapter, as shown by the

⁷⁰ Note that this proposal would also be compatible with the semantics for the (primitive) counterfactual modal given in Stalnaker (1968).

ordering of Tense, Aspect, and the various modal interpretations. As we saw, this ordering was itself motivated by type requirements of Aspect and through binding principles, rather than being determined by a fixed hierarchy.

Our counterfactual modal (CF) needs a time argument and will thus have to be merged below Tense. A modal merged *above* Tense will have an epistemic interpretation, and will scope over CF (by transitivity). A modal merged *below* Tense has a circumstantial interpretation. Aspect moves from the VP to a position where it can combine with a time argument. In the presence of a CF, it won't need to move all the way to T, given that CF provides a time interval that Aspect can happily combine with. Thus, the functional heads should be ordered as follows (without having to recourse to an arbitrary hierarchy):

(255) Mod_{epis} T CF Asp Mod_{circ}

It appears that the range of possible interpretations that we get when our lexical array contains a modal and the *conditionnel* matches this ordering. The French sentence in (a) is ambiguous between what seems to be an epistemic possibility on top of a counterfactual: '*it is possible that they would have won*' (b), or what seems to be a counterfactual on top a circumstantial possibility (ability) '*they would have been able to win*' (c). What (a) lacks, however, is a reading with a CF on top of an epistemic possibility, or that of an ability on top of a counterfactual, thus supporting the above ordering⁷¹.

- (256) a. Ils auraient pu gagner.
 They could-COND win
 b. POSS_{EPIS} > CF
 c. CF > POSS_{CIRC}

⁷¹ I grant that the meaning difference may seem subtle. The following examples, involving a universal modal can help bring out this difference:

- (2) a. Ils auraient dû gagner contre l'Italie.
 They must-pst-COND win against Italy
 b. **Ils auraient dû gagner contre l'Italie, mais Zidane a perdu la tête.** [EPIS>CF]
 '*They should have won against Italy, but Zidane lost his mind.*'
 c. Si les Français n'avaient pas fait match nul avec la Suisse, ils auraient dû gagner contre l'Italie pour arriver en demi-finale. [CF>CIRC]
 '*If the French hadn't drawn against Switzerland, they would have had to win against Italy, in order to get to the semi-finals.*'

Furthermore, if we didn't assume a counterfactual modal, and assumed that the sentence in (a) involved only one modal, with some metaphysical accessibility relation, it isn't clear how one could derive these two readings.

Let's consider English for a moment, where CF is usually expressed by *would*. Note that *would* has to be dropped in the presence of an overt modal (presumably due to some morphological blocking). Consider the pair of examples below:

- (257) a. They might have won.
b. They could have won.

We sense a difference in meaning between the two, where ((257)b) feels 'stronger'/more certain than ((257)a). If we assume a primitive counterfactual modal, and the ordering in (255), we could derive the difference by assuming that ((257)a) corresponds to the first reading of the French sentence ((2)b) (recall that English 'might' can only get an epistemic interpretation), and ((257)b) to the second one ((2)c). Alternatively, we could, of course, say that *might* expresses a less probable counterfactual possibility than *could*. We would, however, still need to explain why they get the readings they get, postulate that French *pouvoir* is ambiguous between these two flavors of counterfactuals, and treat as accidental the fact that *might* expresses epistemic possibility. Thus, while this data may not be a proof of existence for this CF, it is compatible with its existence. Assuming such a counterfactual modal allows a straightforward explanation of the data, in combination with the relative ordering of Tense and the various modal interpretations that our binding possibilities have derived.

5. CONCLUSION

In this chapter, I have tried to motivate a view according to which the reason why epistemics tend to scope high and root modals low falls out naturally, given two principled assumptions, which were needed to derive the actuality entailment pattern. The first assumption was that all accessibility relations are keyed not to a world, but to an event. As we saw, it appears that all modals are relative both to a time and an individual. Having the accessibility relation take an event argument allows such relativization quite naturally, and purges out effortlessly the wrong time-individual pairs: the time anchoring obtains via the temporal trace of the event, the individual anchoring via the agent or experiencer relation with the event. The second assumption

was that perfective aspect could move above the modal, and thus bind the event argument of the modal. As we saw in chapter 1, this movement resulted from treating aspect as a quantifier over events. This assumption both allows us to derive actuality entailments (by yielding an actual event), and the relativization of subject-oriented modals to the circumstances of the event.

CHAPTER 4: ITALIAN *VOLERE* (WANT) AS AN ATTITUDE-MODAL HYBRID

0. INTRODUCTION

The first three chapters of this dissertation focused on modal auxiliaries in French and Italian. The main challenge there was to provide a single lexical entry for each, and still derive the syntactic and semantic differences between the various interpretations they receive through their accessibility relations (epistemic, deontic or circumstantial). My proposal was based on the hypothesis that a modal's accessibility relation has an event variable that needs to be bound locally, either by the speech event, or by Aspect, when Aspect moves above the modal. This movement of Aspect above a modal relied on two assumptions: (i) (Perfective) Aspect is a quantifier over events, which gets merged as an argument of the verb (itself, a predicate of events) and has to move to a position under T in order to combine with a time pronoun; (ii) Modals are functional heads: they are not predicates of events, and thus, do not have their own event argument (although they do have a free event variable in their accessibility relation). They can be merged either above or below Tense. In the latter case, Aspect will move above the modal in order to combine with the time pronoun in Tense, and will thus become the closest binder for the event argument of the modal's accessibility relation. This configuration yields an actuality entailment: Aspect's world argument has to be bound in its target position by the matrix world binder (the only possible world binder), thereby anchoring the event in the actual world.

In Chapter 3, we briefly talked about attitude predicates as possible binders for free event variables. In the tradition of Hintikka (1962), we took attitudes to quantify over possible worlds (e.g., *believe* quantifies over *worlds compatible with the CONTENT of the subject's beliefs*). In that sense, attitudes perform a role very similar to that of modal auxiliaries. There are, however, striking differences. One crucial difference is that, unlike modals, attitudes are predicates of events, like verbs, which have to combine with an event argument. Thus, a sentence involving an attitude predicate will require two event quantifications: one over the attitude's event argument, and one over the event of its complement. This is why, presumably, we do not get actuality entailments with attitudes like *believe*. Thus, the following sentence is not a contradiction:

(258) a. Jane a cru que Darcy était parti, mais il était en fait encore à Londres.

Jane thought-pfv that Darcy was gone, but he was in fact still in London.

b. [Jane T **Asp₁** think(**s₁**) λw_2 [Darcy T **Asp₃** gone (**e₃**, **w₂**)]]

In this chapter, I would like to focus on an attitude-modal ‘hybrid’ which shares common traits with both attitudes and modal auxiliaries: the predicate *want* in Italian. Syntactically, in French and Italian, *want* either takes a bare infinitival complement (just like modals do), or a clausal complement with subjunctive: a full complement with indicative as in (258) is completely out. We saw that French and Italian root modals share the same implicative behavior with perfective aspect, namely they force the proposition expressed by their complement to hold in the actual world. As it turns out, French *want* (*vouloir*) differs from Italian *want* (*volere*) in that the latter forces actuality entailments with perfective⁷²:

(259) a. Lizzie a voulu parler à Darcy, mais elle ne lui a pas parlé.

b. Lizzie ha voluto parlare a Darcy, #ma non gli ha parlato.

Lizzie wanted-pfv talk to Darcy, (#)but she didn’t talk to him

The Italian data in (259)b) is rather puzzling. What (259)b) means roughly is that Lizzie talked to Darcy, and that was in accordance with her desires.⁷³

⁷² The data with *volere* is subject to an additional complication involving the Perfect. Both in Italian and French, the aspectual morphology is impoverished when the Perfect is involved. Perfect is an operator which selects a time interval (cf. Iatridou et al., 2001). It can either have imperfective aspect (universal perfect), or perfective aspect (existential perfect). However, French and Italian use perfective morphology (*passé composé*) to express the Perfect (whether it is a universal or an existential perfect) (S. Iatridou, p.c.). Thus, while the following examples may appear like counterexamples to the actuality entailment generalization, they involve a Universal Perfect (and hence, the aspect is underlyingly imperfective (habitual) rather than perfective):

(i) Darcy ha sempre voluto parlare a Lizzie ma non so perchè non ci è mai riuscito.
D. has always wanted to talk to L., but I don’t know why he never managed to.

⁷³ English speakers may get a feel for this with a particular reading of *won’t* (I. Heim, p.c.). In the example in (i), it seems that we’re both asserting that the complement hasn’t/will not take place, and furthermore that Lizzie lacks any desire for it to be realized:

(i) Lizzie just won’t marry poor Mr. Collins.

Note that the actuality entailment also goes through with *volere* with a passive:

(ii) Darcy ha voluto essere amato da Jane.

So it is not so much *doing* something willingly, but rather being involved in an event which is compatible with one’s desires.

Note that *volere* with perfective aspect is not factive (like *know*): the complement is not taken to hold in the actual world when embedded under negation (the way it is in ‘*Lizzie doesn’t know that Darcy is here*’). Rather, *volere* with perfective behaves like an implicative predicate (such as *manage*): when negated, we get an entailment that the complement did **not** take place in the actual world (as we do with rot modals):

- (260) Lizzie non ha voluto parlare a Darcy, #ma gli ha parlato.
Lizzie not wanted-pfv talk to Darcy, #but she talked to him anyway.

The goal of this chapter is to figure out some of the syntactic and semantic properties of *volere* and contrast it to its French (and English) counterpart: what does *volere* share with root modals, and what does it share with attitudes? What underlies the difference in implicative behavior between the two languages? As we will see, the difference cannot be conceptual. It has nothing to do with Italians being more complacent or being better at getting what they want. Rather, the difference has to be rooted in something structural. Consider the following Italian examples⁷⁴:

- (261) a. ?Lizzie ha avuto voglia de parlare a Darcy, ma non gli ha parlato.
Lizzie has had-pfv want_{NP} to talk to Darcy, but she didn’t talk to him.
Lizzie had ‘want’ to talk to Darcy, but she didn’t talk to him.
- b. A Lizzie è venuto voglia de parlare a Darcy, ma non gli ha parlato.
To Lizzie came-pfv want_{NP} to talk to Darcy, but she didn’t talk to him.
To Lizzie came want to talk to Darcy, but she didn’t talk to him

The closeness in meaning between (259)b) and (261) shows that the implicative behavior of *want* cannot result from some sort of pragmatic reasoning. We found a similar contrast between *have the possibility to* and a root possibility modal, and argued there that the difference in implication had to do with structural rather than pragmatic factors (cf. Introduction). As we will see, French and Italian *want* show some structural differences independently of actuality entailments: *volere* is a Restructuring predicate (Rizzi 1978), while *vouloir* isn’t. The term Restructuring applies to those constructions where the infinitival complement ‘appears to be a transparent domain for

⁷⁴ Informants report that (a) is a bit odd. This oddity seems to come from the usually markedness of putting perfective aspect on a stative predicate. The inchoative version in (b) is perfectly acceptable.

syntactic phenomena that are otherwise quite local (clause bound)’ (Wurmbrand 2001: 1). One such phenomenon is ‘clitic-climbing’, which is allowed with *volere* but not with *vouloir*:

- (262) a. Darcy **la** vuole sposare.
 b. *Darcy **la** veut épouser.
 Darcy her wants to marry

Note that the problem with (262)b) is not that French clitics cannot climb. They do so, for instance, with causatives, as in the example below. Thus, the issue is with *vouloir* and its complement.

- (263) Darcy **le**₁ lui a fait faire **t**₁.
 Darcy it to-him has made do.
 ‘Darcy made him do it’.

The literature on restructuring is vast, and I couldn’t possibly give it justice in this chapter. There are essentially two main approaches to the phenomenon: the ‘bi-clausal’ and the ‘monoclausal’ approach. With the former, the complement of a Restructuring Verb (RV) starts out as a clausal (CP) complement and then undergoes some rule of ‘restructuring’, ‘deletion’ or reanalysis, which erases a clause boundary and makes the domain transparent (cf. Rizzi 1978, 1982 a.o.). With the monoclausal account, the complement starts out small. This is the view defended by, e.g., Wurmbrand (1998, 2001), who argues that a restructuring predicate such as *volere* forms a single clause with its complement: it only has one CP, one Tense, and one vP projection. Contrastively, a non restructuring predicate such as *vouloir* is biclausal.

Assuming that a sentence involving *volere* does indeed only have one Tense projection, one could derive an actuality entailment in a way analogous to the process that yielded actuality entailments with root modals. Namely, we would allow Aspect to move from a base position in the complement VP up to a position right below T in the matrix. This way, Aspect’s world argument could not be bound by the modal element of *volere*, but instead, would have to be bound by the default matrix world binder, forcing the event to be anchored in the actual world. The structural difference I thus propose between French and Italian is schematized below:

- | | | | | | | |
|-----------------------|---|---------------------|------|---|---------------------|------------------|
| (264) <i>Italian:</i> | T | Aspect ₁ | want | | V | e ₁ |
| <i>French:</i> | T | Aspect ₁ | want | T | Aspect ₂ | V e ₂ |

This chapter will be organized as follows. Section 1 will be devoted to the semantics of *want* and its Italian counterpart. We will see how combining elements of attitudes and of roots into the semantics of *volere* can derive actuality entailments with perfective aspect. In section 2, I will review some syntactic evidence that supports my claim that the difference between Italian *volere* and its French counterpart w.r.t. actuality entailment is essentially structural, and will boil down to a difference in the number of event quantifiers. In section 3, we will then consider some interesting facts involving the presuppositions triggered by *again* in the two languages, which will shed some light on the question of ‘size’ of the complements of *restructuring* predicates, and support a single event approach.

1. SEMANTICS OF *WANT*, *VOULOIR* AND *VOLERE*

In this section, we will first try to understand the semantics of *want/vouloir*, and then see how *volere* differs. We will further show how to derive actuality entailments with perfective on *volere*.

1.1. SEMANTICS FOR *WANT*

In a Hintikka-semantics, where attitudes are treated as quantifiers over possible worlds, *want* is a universal quantifier over worlds in which the subject’s desires obtain. Thus *Jane wants to go to London*, will mean roughly ‘*In all of Jane’s desire-worlds, she goes to London*’. This picture is, unfortunately, too simplistic. Indeed, we have reasons to believe that quantifying over desire worlds doesn’t suffice. Based on Karttunen’s (1973, 1974) original observation, Heim (1992) shows that it cannot capture the way presuppositions project under attitude verbs. Consider the following examples:

(265) Patrick wants to sell his cello. [Heim (1992)]

The sentence in (265) seems to presuppose that Patrick owns a cello. The presupposition triggered by the definite description (*his cello*) in the embedded complement seems to project. Thus, we do not understand the sentence to mean merely that ‘*Patrick owns a cello in all of his desire worlds*’ but rather than ‘*Patrick owns a cello in the actual world, and wants to sell that*

cello in all of his desire words'. Heim further shows that when we build a context in which it is established that Patrick has the erroneous belief that he owns a cello (as in (266) below), we no longer presuppose that Patrick does own a cello in the actual world:

(266) Patrick is under the misconception that he owns a cello, and he wants to sell his cello.

These projection facts lead Heim (1992) to propose a conditional semantics for *want*, which builds on Stalnaker's (1984) insight that every desire report contains a hidden conditional:

- (267) a. Caroline wants Jane to leave.
 b. C. thinks that if J. leaves, she will be in a more desirable world than if J. doesn't.

Crucially, Heim proposes that the worlds quantified over are not mere desire worlds, but rather, doxastic alternatives ('belief' worlds). The desirability component of *want* comes from a comparison among those worlds between those in which the complement holds and those in which it doesn't⁷⁵:

- (268) a. ' α wants ϕ ' is true in w iff: for every $w' \in \text{Dox}_\alpha(w)$:
 Every ϕ -world maximally similar to w' is more desirable to α in w than any non- ϕ -world maximally similar to w' .
 b. $\text{Sim}_w(p) = \{w' \in p \text{ and } w' \text{ resembles } w \text{ no less than any other world in } p\}$

Note that this quantification over doxastic alternatives is supported by the contrast between *want* and *wish*: While we can *wish* for something which we know we cannot get, we cannot *want* it (cf. Portner 1994; Giorgi and Pianesi 1997). The contrast in (269) highlights the fact that the subject has to believe that the complement is epistemically possible:

- (269) a. #Jane wants the Earth to be flat.
 b. Jane wishes the Earth to be flat.

⁷⁵ Various accounts have since been proposed to handle the original presupposition projection facts of desire predicates, and additional data that involve comparing the desirability of the complement p to possible alternatives other than $\neg p$. See in particular Villalta (2000) for an account in terms of contextually-given alternatives, and Levinson (2003) for a probabilistic model-theoretic account. For our purposes, I will put these extra complications aside and assume a more 'traditional' account.

How can we adopt Heim's insight in our current framework? To simplify things a bit, I will follow von Fintel (1999)'s variant, which essentially treats *want* as a modal with an epistemic modal base and a (bouletic) ordering source, instead of having a conditional semantics for *want* (see also Giorgi and Pianesi 1997):

- (270) $[[\text{want}_i]]^{f,g}(p)(\alpha)(w)$ is defined if
- (i) $f_i(\alpha, w) = \text{DOX}(a, w)$
 - (ii) $f_i(\alpha, w) \cap p \neq \emptyset$
 - (iii) $f_i(\alpha, w) - p \neq \emptyset$
- if defined, $[[\text{want}_i]]^{f,g}(p)(a)(w) = 1$ iff $\forall w' \in \max_{g_i(\alpha, w)}(f_i(\alpha, w))$: $w' \in p$

In von Fintel's system, f and g are parameters, which are functions from indices (here, i) to modal bases and ordering sources. The way he ensures that the modal base consists of belief worlds is through a presupposition: the wrong modal base will yield a presupposition failure. Let's assume that the ordering source is some kind of bouletic ranking, which picks out the most desirable worlds for α among α 's doxastic alternatives.

We now need to recast this lexical entry in our event-based framework. Recall that I treat attitude predicates as taking a special eventuality argument, that is, an event/state argument that has CONTENT. The CONTENT of, say, a belief state is the set of propositions that its experiencer believes to be true in the base world. The following example from chapter 3 illustrates. Note that this is a bit different from von Fintel's system above, as the accessibility relation is simply wired in the lexical entry of *believe*:

- (271) a. Darcy believes that it is raining.
 b. $\exists s[s \text{ in } w^* \ \& \ \tau(s) \supseteq t^* \ \& \ \text{Exp}(s, D.) \ \& \ \text{believe}(s) \ \& \ \forall w' \in \text{CON}(s): \text{it is raining at } \tau(s) \text{ in } w']$
 where $\text{CON}(s) = \bigcap \wp$ and $\wp = \{p \mid p \text{ is a belief of the experiencer of } s \text{ at } \tau(s)\}$

believe takes a (CONTENT) state argument and quantifies worlds compatible with the CONTENT of this (belief) state: in all worlds compatible with the CONTENT of Darcy's belief state, it is raining.

Want will differ minimally from *believe* by having an extra bouletic ordering source, also wired in the lexical entry. This ordering source will further restrict the domain of quantification to those most desirable worlds among those compatible with the beliefs of the subject. Thus, I propose the following lexical entry for *want/vouloir*:

$$(272) \quad [[\text{want}]](s)(p) = 1 \text{ iff } \forall w \in \text{DES}(s): p(w) = 1$$

$$\text{where } \text{DES}(s) = \max_{\text{experiencer}(s)}(\text{CON}(s))$$

Note that *want* will combine with its experiencer via some stative voice head which introduces the external argument of states (cf. Kratzer 1996; for more details, see chapter 1, section 2.1.2.1). We thus obtain the following:

- (273) a. Darcy wants it to rain.
 b. $\exists s[s \text{ in } w^* \ \& \ \tau(s) \supseteq t^* \ \& \ \text{Exp}(s, D.) \ \& \ \text{want}(s) \ \& \ \forall w' \in \text{DES}(s): \text{it is raining at } \tau(s) \text{ in } w']$

As was the case with *believe*, we do not get actuality entailments with this *want/vouloir*. This, again, falls out straightforwardly under the assumption that attitudes come with their own eventuality argument (which needs to be quantified over) and have a complement, whose event argument also has to be saturated within its clause:

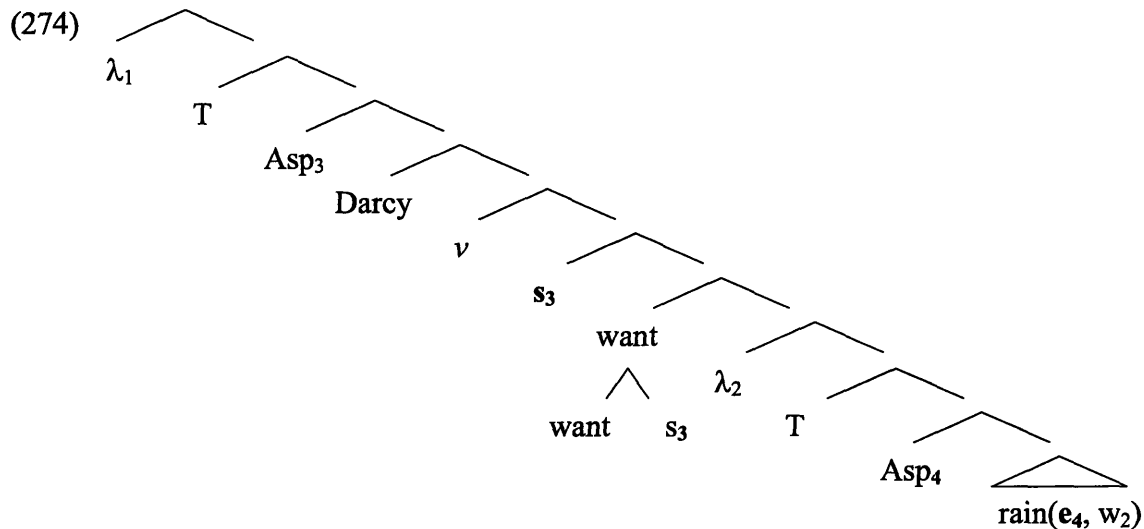

The hypothesis that I will pursue in the next section is that Italian *volere* differs precisely in this assumption: contra *vouloir/want*, *volere* lacks an event argument, and, instead, allows Aspect to raise from the complement, to a position above it.

1.2. VOLERE

How much does *volere* share with its French and English counterparts? As far as meaning is concerned, quite a lot. We still want to quantify over the subject's most desirable belief-worlds. However, as they stand, the semantics given above won't derive the actuality entailment associated with perfective on *volere*. What we see is that, in this respect, *volere* behaves more like a root modal. Let's thus briefly review how we derived an actuality entailment with a root modal. In the sentence below, the modal is merged below T. Aspect moves out of the VP above the modal, and binds the event argument of that modal's accessibility relation, thereby relativizing the modality to the circumstances of the event quantified over by Aspect. Because Aspect is outside of the scope of the modal, its world argument has to be bound by the matrix binder, thereby yielding an actual event (which in some circumstantially accessible world is a running event by Jane):

(275) a. Jane a pu courir.
Jane could-pfv run

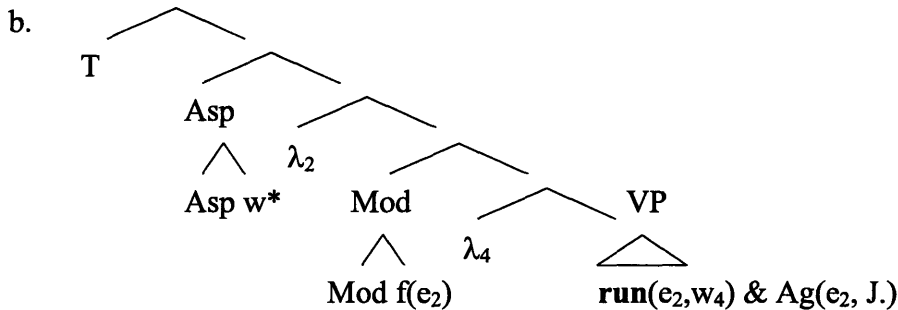

c. $\exists e[e \text{ in } w^* \ \& \ \tau(e) \subseteq t \ \& \ \exists w' \in \text{CIRC}(e): \text{run}(e, w') \ \& \ \text{Ag}(e, J.)$.

d. There is an actual past event e such that in some world compatible with the relevant circumstances of e , e is a running event by Jane.

Similarly for *volere*, we want Aspect to move above the modal element. However, *volere* is not quite a root modal. One important difference is in the type of accessibility relation involved: with *volere* the accessibility relation is fixed: it never has a circumstantial meaning (nor, for that matter, a pure epistemic meaning). We thus need to fix the set of accessible worlds to those compatible with the desires/beliefs of the subject. Note that we still need some relativization of the modality to the *time* of the event quantified by Aspect (that is, the time provided by Tense): the complement holds in all of the worlds compatible with the subject's desires *at that time* (i.e., not *now*).

I thus propose the following: as for its English/French counterpart, *volere*'s accessibility relation is fixed in terms of belief worlds (further restricted by a bouletic ordering source). However, unlike *vouloir/want*, it doesn't have a 'proper' eventuality argument. Thus, it won't be able to combine with its 'experiencer' via a voice head. I assume then that *volere* will take an individual argument *x*. Like *vouloir/want* (and root modals), however, *volere* will still take an event argument in its accessibility relation. This is done in order to relativize the modality to a time: the time of *e*. I thus propose to wire-in a temporal trace relation in the accessibility relation: we will quantify over worlds compatible with the CONTENT of *x*'s belief state at the time of *e*. I take *e* to be a free event variable, which needs to be bound by the closest binder:

$$\begin{aligned}
 (276) \quad & [[\text{volere}]](p)(e)(x) = 1 \text{ iff } \forall w \text{ compatible with } x\text{'s belief state at } \tau(e) \\
 & \qquad \qquad \qquad \text{which are maximally desirable: } p(w) = 1 \\
 & = 1 \text{ iff } \forall w \in \text{DES}(s_{x,\tau(e)}): p(w) = 1 \\
 & \qquad \qquad \qquad \text{where } s_{x,\tau(e)} \text{ is the belief state of } x \text{ at } \tau(e)
 \end{aligned}$$

Unlike the event argument of *want*, the event argument of *volere* does not have a content which determines the set of accessible worlds. It still enables us to *access* a state with content which, in turn, determines the set of accessible worlds: that state is the belief state of *volere*'s individual argument at the time of *e*. A clarification is in order. I have said that *volere* is not a predicate of events. Yet, its lexical entry shows that it does need an event argument. This is due to the fact that I am wiring in the accessibility relation in *volere*'s lexical entry. With modals, we could avoid this problem: they did not select for an event themselves, but, rather, took an accessibility relation, which itself took an event argument. I presume that, as in the case of modals, Aspect cannot be merged in this position, under the assumption that the restriction of modals is an island for extraction, which would prevent Aspect from moving out (cf. Chapter 3). Thus the claim that *volere* differs from *vouloir* in that only the latter is a predicate of events is not exactly correct. Instead, *volere* differs from *vouloir* in that it has an event pronoun build in its restriction, but which doesn't have a content that directly determines the set of accessible worlds. *vouloir*, on the other hand, takes a state argument, whose content directly determines the set of accessible worlds.

Consider a simple case with an infinitive complement. The actuality entailment will thus proceed as follows. *Volere* combines with its complement. Notice from the lexical entry in (276) that I take *volere* to take a proposition as its complement. We can then assume that this

complement has a PRO subject. Perfective Aspect is base-generated inside the complement as an argument of the verb. It then needs to move out to a position above *volere* in order to combine with its time argument in T. Aspect's world argument gets bound by the matrix binder, yielding an actual event (which in all desire-worlds is a P event):

(277) a. Jane ha voluto parlare a Darcy
Jane want-pst-pf talk to Darcy

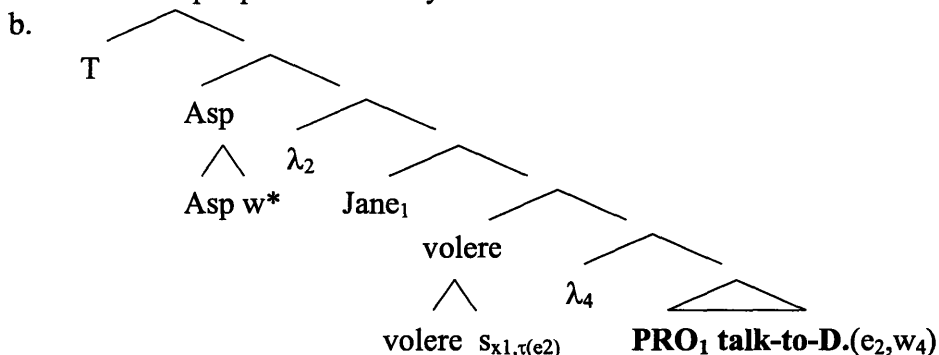

c. There was a past event s.t. in all of the most desirable worlds compatible with the CONTENT of Jane's belief event at $\tau(e)$, e is a talking to Darcy event.

A difficulty arises, given that we let *modals* merge freely above and below tense, *volere* might in principle be able to do so as well. Crucially however, we need *volere* to merge below Tense, and not above, as was the case for epistemic modals. If we let *volere* merge above Tense, then we would wrongly relativize the modality to the time of the speech event, as that speech event would then be the only possible binder for the event variable in *volere*'s accessibility relation. Lizzie may not want to talk to Darcy anymore. In fact, Lizzie might be dead now. I would like to speculate that what prevents *volere* from merging above Tense is due to its taking an individual argument (the subject). If *volere* was merged above Tense, its subject would also be merged above Tense. If this were the case, however, Tense could not enter into an agreement relation with the subject (e.g., lack of specifier-head configuration or c-command), and the syntax would rule this out, assuming subject-verb agreement is done at the TP level (and not higher than the position in which high modals are merged).

From a semantic point of view, this may look a bit baroque. Why not simply say that *volere* takes a property, rather than a proposition with a PRO?⁷⁶ The merging below Tense would be derived naturally for type reasons. The problem is that *volere* can also combine with a CP complement with subjunctive. Now, why not have two *volere*: a property taking one, which yields the correct actuality entailments, and one taking a CP complement, which will have the same semantics as *vouloir/want*? This, unfortunately, will not do: as the following example shows, for some speakers of Italian, *volere* with a CP (subjunctive) complement also yields actuality entailments:

- (278) Bingley ha voluto che Jane partisse, #pero lei è rimasta lo stesso.
 Bingley has wanted-pfv **that** Jane leave-subj, #but she stayed anyway.

Because of cases like (278), we need to have a lexical entry for *volere* which allows actuality entailments, even when the complement is a full (subjunctive) proposition. I assume that those speakers that do not accept (278) only have one *volere*, which takes a proposition as its complement, and whose lexical entry is given in (276). For a proposal for why this complement can only have subjunctive mood, see Villalta (2000). Interestingly, then, we need to assume that the complementizer ‘*che*’ of the subjunctive complement doesn’t block my Aspect movement. Thus, while we *do* have a CP layer in the complement, we do not have a *Tense* projection. Though this may be a bit unconventional, it might be supported by the fact that having a past in the complement is completely out⁷⁷.

- (279) *Bingley ha voluto che Jane fosse partisse.
 Bingley has wanted-pfv **that** Jane be-subj gone.

Some theoretical support for this claim comes from Butler (2004), which proposes to intersperse CP layers above vP and TP. If Butler is right then, having a complementizer doesn’t entail having a tense projection.

⁷⁶ See Moulton (2006) for a proposal that gets rid of PRO with obligatory control (OC) verbs, by having the OC verb be a kind of *voice*: it introduces the external argument itself and combines with its infinitival complement via Event Identification.

⁷⁷ This may not be extremely suggestive, given that the past subjunctive is altogether on its way out in Italian. Informants did allow a past subjunctive when the matrix had past conditionnel morphology, but this is also preferred in French.

Finally, for those speakers that find (278) felicitous, there may be a lexical ambiguity for *volere*: one *volere* would take an infinitival complement and has the semantics in (276), and the other would take a CP-subjunctive complement, and would have the semantics of *want/vouloir*.

To sum up, the crucial difference between French and Italian *want* is that, in French, *want* is first and foremost a predicate of events and, as such, needs to combine with a quantifier over events. Italian *want* on the other hand, is more like a root modal: it isn't (exactly) a predicate of events. However, it differs from root modals in that its accessibility relation is fixed: it picks out the most desirable worlds among a set of worlds compatible with the subject's belief state at the time of the complement, just like its French/English counterpart.

2. RESTRUCTURING PROPERTIES OF *VOLERE*

The moral of the above story is that we can account for the differences in the implicative behavior of *volere* and *want/vouloir* once we assume that they differ in number of event quantification. In the case of *volere*, we need Aspect to be able to move from the complement to a matrix position right below T. Thus, the boundary between *volere* and its complement has to be 'transparent', in a way in which it isn't with *vouloir*. In this section, I review some syntactic evidence that supports such a claim. As we will see, *volere* independently shows some boundary transparency, while its French counterpart doesn't: *volere*, unlike *vouloir*, is a Restructuring predicate.

2.1. *VOLERE* VS. *VOULOIR*: SYNTACTIC DIFFERENCES

While the syntax of French and that of Italian have much in common, a noticeable feature that sets them apart is a phenomenon known in the literature as *Restructuring*. A predicate is said to be a 'Restructuring Verb'⁷⁸ (RV) when its infinitival complement seems to be transparent to syntactic phenomena, which are usually clause bound. The sort of syntactic phenomena varies from language to language. In Germanic languages, for instance, long distance scrambling, long passive and verb raising are all symptomatic of restructuring. In Romance (Italian, Spanish), the hallmarks of restructuring include clitic climbing (where a clitic which is interpreted in the complement clause appears in the matrix), auxiliary switch, and object preposing. One important

⁷⁸ I will continue calling *volere* a restructuring 'verb', even though I take it not to be a predicate of events (despite the event in its restriction).

difference for our purposes is that, while in (Modern) French clitic climbing is very restricted (causatives, but not modals nor aspectual verbs), it is found across a wide range of constructions in Italian (modals, motion verbs, aspectual verbs, causatives...). In particular, *want* is a restructuring verb in Italian, but not in French. Recall that the former allows clitic climbing while the latter doesn't:

- (280) a. Darcy **la** vuole sposare.
b. *Darcy **la** veut épouser.
Darcy her wants to marry

According to Wurmbrand (1999) and others (cf. Napoli 1981, Rochette, 1988, Rosen 1989), Restructuring is symptomatic of having a complement which is not fully clausal. Just how big is that complement? While all 'monoclausal' approaches agree that it lacks a CP and a TP projection, there is a certain amount of debate about whether it also lacks an Aspect Phrase or not. In Section 2.2, I will review Wurmbrand's arguments for a monoclausal structure. In Section 2.3, I will discuss how actuality entailments with perfective relates (or doesn't relate) to Restructuring. In section 3, I will discuss the main point of contention with other monoclausal accounts, namely whether restructuring infinitives involve a single event, or two. Wurmbrand argues against event unification accounts based on data involving the adverb *again*. I will show that, in a sense, both types of accounts are right (as far as *volere* is concerned): while the complement does consist of a predicate of events, its event variable is however not saturated inside the complement but rather at the matrix level. Thus data will support my proposal that *volere* involves Aspect movement.

2.2. THE MONOCLAUSAL APPROACH TO RESTRUCTURING⁷⁹

Wurmbrand (1998) argues that a sentence with a restructuring verb, such as *volere*, is monoclausal: it has a unique functional part (CP, TP, vP) and a recursive lexical part (various VP levels). Based on evidence from Dutch and German, she shows that the complement of a RV lacks a CP projection. In the following Dutch sentence, when the object of the complement

⁷⁹ Wurmbrand (2001) makes a distinction between 'lexical' RVs (e.g., *try*) and 'functional' RVs (modals). The crucial difference for her is that while the former result from 'an optional combination with a small complement, functional restructuring is a direct and unavoidable result of the architecture of the clause'. This difference doesn't immediately affect our discussion, as we always get an actuality entailment, when the complement of *volere* is a bare infinitival, whether clitics climb or not.

clause is scrambled to the matrix (a symptom of restructuring in Dutch), as in (a), an overt complementizer is bad, while it is fine if the object is not scrambled, as in (b):

- (281) a. Dat Jan [die brief]_i probeerde [(***om**) zijn broer t_i te schrijven] [Wurmbrand 1998]
 That Jan the letter tried [COMP his brother t to write]
- b. Dat Jan probeerde [(**om**) zijn broer die brief te schrijven]
 That Jan tried [COMP his brother the letter to write]

Wurmbrand further shows that complements of RVs are tenseless. Indeed, there is no tense shifting with an RV such as *try*:

- (282) #Hans versuchte Sue in zwei Monaten in Wien zu besuchen. [Wurmbrand 1998]
 #Hans tried to visit Sue in two months.

Intuitions for *volere* are a bit less straightforward. As was hinted at in chapter 2, for modals, the future-orientation may be due to the presence of a counterfactual modal associated with imperfective, rather than from the semantics of the modals themselves:

- (283) a. *Bingley a pu partir demain.
*There was an event whose running time is **included** in the (past) reference time such that in some world it is an event of leaving tomorrow by Bingley.*
- b. Bingley pouvait partir demain.
There was a past time, s. t. in all metaphysically accessible worlds, there is an open interval whose left boundary is that past time, s. t. there is an event whose running time is included in that open interval, s. t. in some world it is an event of leaving tomorrow by Bingley.

With imperfective, because of the open interval provided by the counterfactual modal, the running time of the event is **not** contained in the past reference time, it is left open when the event takes place within that interval (i.e., it could happen at a time after the speech time). With perfective, however, because the running time of the event is contained within the reference time, the future-oriented adverbial yields a contradiction. Similarly for *volere*, tense shifting is bad with perfective, but fine with imperfective:

- (284) a. *Dieci giorni fa, Darcy ha voluto parlarle oggi.
 Ten days ago, Darcy has wanted-pfv to talk to her today
- b. Quando Darcy era piccolo, voleva diventare senatore.
 When Darcy was young, he wanted-impf to become a senator

Wurmbrand (1998, 2001) further argues that complements of RVs do not have structural case, because they lack a vP projection, the projection responsible for licensing a subject and assigning accusative case (cf. Kratzer 1996). In the example below, *der Traktor* gets nominative case because (i) there is no vP layer in the complement to assign it case, and (ii) the passive of the matrix suppresses accusative there as well:

(285) Der Traktor wurde zu reparieren versucht. [Wurmbrand 2001]
The tractor-NOM was to repair tried

Thus, Wurmbrand proposes that restructuring infinitivals do not have a CP, a TP, nor a vP layer. However, she argues, VPs themselves include an “inner aspect phrase” (cf. Travis 1992, 1994), and as a result, a sentence with a RV will have two separate events (the event of the matrix and that of the complement). I will challenge this conclusion in section 3, and propose instead that RVs (at least *volere*) involve a single event quantifier, which originates in the complement and raises to the matrix in order to combine with a time pronoun in Tense.

2.3. ASPECT MOVEMENT AS A TRANSPARENCY EFFECT

The restructuring effects found with *volere* support my hypothesis that structural factors between French and Italian are responsible for a difference in implicative behavior. Do these structural factors involved in actuality entailments correlate completely with the structural difference involved with, say, clitic climbing? Is there a single factor or structure responsible for all of the transparency effects brought together under the label ‘Restructuring’?

While the data I present in the next section will require some fine tuning of the aspectual assumptions of current approaches to Restructuring, I won’t be proposing a new all inclusive theory, and will further remain agnostic about whether ‘Restructuring’ can be treated as a uniform phenomenon. Instead, I would like to add the Aspect movement responsible for actuality entailments to the list of ‘transparency effects’ associated with a restructuring verb like *volere* or like a root modal. I propose that this aspect movement (and thus actuality entailments) results from the fact that a verb like *volere* only involves one event quantifier (i.e., Aspect), which originates in its complement.

As we saw in the previous section, one of the main indicators of Restructuring in Italian is clitic-climbing. However, while clitic climbing might be a good predictor for actuality entailments (it is, after all, allowed both with root modals and *volere*), a lack of clitic climbing doesn't necessarily entail a lack of actuality entailment. For instance, perfective on *volere* yields actuality entailments even when a clitic stays in the complement:

- (286) Lizzie ha voluto gli parlare, #ma non gli ha parlato.
Lizzie wanted-pfv him talk, #but she didn't talk to him.

Wurmbrand argues that the absence of clitic climbing is compatible with two different structures (the complement is either small, i.e., there is *restructuring*, or it is bigger). If Wurmbrand is right, and if actuality entailments only obtained with a 'small' complement, then we would not expect to have an actuality entailment in (286): a charitable informant would accommodate a structure with the larger kind of complement (e.g., a full CP complement), in order to avoid a contradiction. However, the entailment is unavoidable, thus either the structure is always small (*contra* Wurmbrand), or actuality entailments must also occur in the larger type of complements as well. As we saw in section 1.2, *volere* can, in fact, take a larger CP complement (with subjunctive) and *still* get actuality entailments. Given this, the complement in (286) could be larger, and the issue of actuality entailment doesn't revolve around *size per se*.

Thus, while the presence of a complementizer might prevent clitics to climb⁸⁰, it would still allow Aspect to raise, when the CP is in the subjunctive mood. Interestingly, the fact that Hungarian allows aspectual particles to climb out of a subjunctive complement above *akar* (*want*) (cf. É.Kiss 1999; Koopman and Szabolcsi 2000; Abrusan 2005) seems to corroborate this claim:

⁸⁰ Note that, even in Romance, we can find transparency effects in the presence of a complementizer, as the following examples show (from Brody 1999, as reported by Abrusan 2005): (a) is a case with *si* passive in Italian, and (b) an *easy to please* construction in French. We even have a case of clitic climbing above *know* in Italian in (c).

(i) a. ?Certe riposte non si sanno mai come dare.
One never knows how to give certain answers
b. ?Ce genre d'article est difficile à savoir où classer.
This kind of article is hard to know where to file.
c. ? Mario, non lo saprei a chi affidare.
Mario, I would not know to whom to entrust him

(287) János szét akarja [hogy szétszedjem a rádiót]
Janos apart wants that take-1sg.sbj the radio-acc
'Janos wants me to take apart the radio'

[Abrusan (2005)]

What this data suggests is that 'size' doesn't matter for actuality entailments, if size means having a CP layer. What matters, I claim, is whether we have one or more aspectual quantification. For this claim to go through, however, we need the presence of a complementizer (such as those involved in subjunctive complements) to be compatible with a lack of a TP or AspP layer (cf. section 1.2).

To sum up, I have proposed that a sentence with *volere* will only involve one event quantifier, even in cases where it takes a CP-complement in the subjunctive, for the group of speakers that find (279) infelicitous. This event quantifier originates from the embedded VP and raises to T above *volere*, thereby yielding an actual event. What licenses this aspect movement in Italian is that *volere* doesn't have its own event argument, and will thus allow a lower quantifier over events to raise to the matrix T. Thus, while my proposal is compatible with a monoclausal approach to Restructuring in the cases that involve clitic climbing (with infinitival complements), it crucially advocates that the complement doesn't have its own Aspectual quantifier, separate from an aspectual quantifier in the matrix. In the next section, I will show some empirical evidence to support this claim.

3. IN DEFENSE OF THE SINGLE EVENT QUANTIFICATION VIEW

Wurmbrand (1998, 2001) discusses various proposals which she groups together as *event unification* accounts. While she classifies the event unification accounts in the same 'monoclausal approach' where she places her own analysis, she fundamentally disagrees with their claim that Restructuring involves a single event. There are several variants of the event unification approach. Rosen (1989, 1990) suggests that RVs are light verbs, with an empty argument structure, and thus have to undergo *argument structure merger*, a process which superimposes the empty argument structure of the RV onto that of the embedded verb. Rochette (1988, 1990) argues that RVs are like auxiliaries in that they lack an event argument in their theta-specification. Assuming that INFL performs existential closure over event variables (cf. Higginbotham 1985), with a RV, INFL will directly bind the event variable in the complement. This account is thus very close in spirit to the one proposed here. Napoli (1981) argues that a

sentence with a RV contains a single event, based on evidence with adverbial modification, such as *di nuovo* (*again*). As with auxiliaries, adverbial modification of the matrix (the RV) entails modification of the embedded predicate. Napoli claims that it is not possible for *again* to modify only the RV without the complement. Consider the following examples:

- (288) a. Voglio di nuovo imprigionarli. [Napoli (1981)]
 I want again imprison them
 b. Li voglio di nuovo imprigionare.
 Them I want again imprison
 ‘I want to imprison them again’

(a) and (b) differ in the placement of the clitic. (b) shows clitic-climbing, indicating restructuring, whereas (a) is the non restructuring version of *want*. Napoli claims that while *again* can modify either the event denoted by the complement clause (i.e., *imprison*) or the matrix one (i.e., *want*), the latter modification is impossible in the presence of restructuring in (b). The argument goes as follows: *again* is an adverbial modifier which triggers the presupposition that a previous event of the same type took place. Thus, when it modifies the lower ‘event’, it triggers the presupposition that there was a previous *imprisoning* event, whereas if it modifies the upper event, it triggers the presupposition that there was a previous *wanting* event. According to Napoli, (a) is compatible with a scenario where there was a previous imprisoning (without necessarily a previous *desire*) or a scenario where there was a previous desire (without necessarily a previous *imprisoning*). (b) on the other hand is only compatible with the first scenario (previous imprisoning).

Wurmbrand (2001) argues that Napoli’s claim is too strong: first, *again* doesn’t need to modify both the RV and the embedded predicate, but just the embedded one (i.e., undesired imprisoning). Second, she shows that the impossibility for modifying the matrix event might be due to the position of the adverbial which favors a narrow scope interpretation w.r.t. *want*. When ‘again’ is placed at the end of the sentence, both the restructuring and non restructuring versions are compatible with both scenarios. She shows that the example below is compatible with two scenarios (among others). In the first scenario, Darcy has already married Lizzie against his will, then they divorced, but now he wants to marry her again: there is a previous (unwilling) *marrying* event. In the second scenario, Darcy and Lizzie never got married but he has had a desire to in the past (there is a previous *wanting* event):

(289) Darcy la vuole sposare di nuovo.
Darcy her wants to marry again

[Wurmbrand (1998)]

The compatibility with either scenario leads Wurmbrand to claim that, even with restructuring, we have two events which can be modified, and thus, the event union approach cannot be right.

3.1. VOLERE AND AGAIN

Things take an interesting turn when we put perfective aspect. All of a sudden, the scenario where there was a previous desire, but no actual marrying is out. Note that French *vouloir*, on the other hand, allows either scenarios regardless of aspect:

- (290) a. Darcy la ha voluta sposare di nuovo.
Darcy has wanted-pfv to marry her again
- b. Darcy a voulu l'épouser à nouveau.
Darcy her wanted-perf to marry her again

This is so, even if we prepose *di nuovo* to favor matrix modification. Thus, contrary to French, in Italian, the sentence seems to presuppose (obligatorily) a previous marrying event. It does not, in passing, have anything to do with the stativity of *want*. The periphrastic *avere voglia* (*have want*), which, as you recall, doesn't yield an actuality entailment, is fine with either scenario:

- (291) Darcy ha avuto voglia di sposarla di nuovo.
Darcy has had want to marry her again.

Note, for completeness sake that imperfective (past) on *volere* yields the same presuppositions as with present tense. As we saw in chapter 2, it isn't surprising that the present should pattern with the *imparfait*, given that we could never have a present perfective. Thus, the two scenarios are fine:

- (292) a. Darcy voleva sposarla di nuovo, ma lei non ha voluto.
Darcy wanted-imp to marry her again, but she hasn't wanted to.
Presup.: previous *marrying* event.
- b. Di nuovo, Darcy voleva sposarla, ma encor una volta lei non ha voluto.
Again, Darcy wanted-imp to marry her, but one more time, she hasn't want to.
Presup.: previous *wanting* event.

To sum up the data with *again* in *want* sentences, one presupposition that can always get generated, in both languages and with both aspects, is that of a previous marrying event (without requiring a previous wanting event). This presupposition presumably obtains when *again* attaches at the complement level. When *again* attaches at the matrix level, we should obtain a previous *wanting* event, and we actually do for French (with both aspects) and for Italian imperfective sentences. Crucially, however, this presupposition does *not* get generated when *volere* takes perfective aspect. There are thus two differences that our account needs to explain. First, we need to derive a difference within Italian, in the presuppositions triggered by *again* with the two aspects (imperfective and perfective). Second we need to explain why French and Italian differ in the presuppositions triggered by *again* on *want*, when perfective aspect is used. Importantly, we cannot assimilate the case of perfective *want* in French to the Italian imperfective cases. Indeed, given that French yields actuality entailments with perfective aspect on root modals, the solution cannot come from the semantics of French perfective. Instead, the solution should be derived from structural differences in the complements of the two languages (the case of perfective *want* in French should be assimilated with that of perfective on Italian *avere voglia*). The solution for the *within-language* problem, on the other hand, cannot come from a structural difference along the same line as in the between-language case. Indeed, we should maintain a somewhat parallel structure between two sentences which differ only in aspect (*modulo* the extra modal layer associated with imperfective).

3.2. AGAIN

In order to understand what underlies the differences in the presuppositions generated by *again*, we need to take a closer look at its semantics. The adverb *again* takes a property of events P and an event e, and triggers the presupposition that there is an event e' located before e for which the property P holds. The following lexical entry is from Beck and Johnson (2002) and is virtually identical to that of von Stechow (1996):

- (293) $[[\textit{again}]](P_{\langle e, t \rangle})(e)$ = 1 if $P(e) \ \& \ \exists e'[e' < e \ \& \ P(e')]$
= 0 if $\sim P(e) \ \& \ \exists e'[e' < e \ \& \ P(e')]$
undefined otherwise

A large part of the literature on *again* focuses on the so-called restitutive/repetitive ambiguity. Consider the following example:

(294) Lydia opened the door again.

The above sentence either presupposes a previous action of opening the door by Lydia (the repetitive reading) or it presupposes that there was previous time at which the door was open, even if Lydia never touched the door (the restitutive reading). The explanation for this ambiguity is either done by postulating a lexical ambiguity of *again* (Dowty 1979), a meaning postulate (Fabricius-Hansen, 2001) or by keeping a unified semantics for *again* but allowing it to attach at different heights, once we decompose the meaning of *open* into a result state of being open, and an agentive event of causing that result state (von Stechow 1995, 1996; Beck and Johnson 2002). In the following, I will assume such a structural account. For arguments in its favor, and against a meaning postulate, I refer the reader to von Stechow (1996).

With such a structural account, *again* always operates on properties of events (and always indicates repetition, even on the restitutive reading (Beck and Johnson 2002)). Therefore, it can attach at any node that denotes a property of events. Thus, the fact that *di nuovo* (*again*) can modify the event denoted by the complement of *volere* (*want*) or the event denoted by the matrix doesn't imply that there are two separate events *per se*, but rather that the sentence contains two event properties. Thus, if we have two event properties and a single event binder, which can bind the event arguments of both, we have two places of attachment for *again* and still a single event.

However, we run into a technical problem with the aspect as a generalized quantifier approach, independent of the semantics of the modal. To see this, let's look at the sentence in (295)a). Recall from the previous chapters that I am making the following assumptions: worlds are expressed overtly in the syntax as explicit world pronouns, which obey certain binding principles (per Percus 2000); in particular, the world arguments of any projection on the 'spine' of the tree (Tense, Aspect, Modal, voice, Verb) have to be bound by the closest binder. I am further assuming that perfective is base-generated as an argument of the verb and moves up for type reasons. Now, *again* needs to attach at a node of type $\langle \epsilon, t \rangle$. Given that world pronouns are explicit, vPs will be of type $\langle t \rangle$. Thus, the only place where *again* could attach would be between the moved quantifier and its binder index (position **1**):

- (295) a. Darcy la ha sposare.
 Darcy her has married
 b.

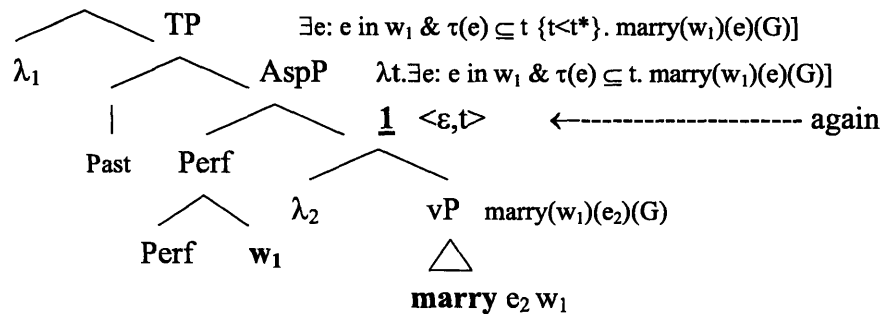

Making this position available for attachment may seem a bit *ad hoc*. First of all, it requires a particular view of movement and predicate abstraction, where the binder index forms a constituent with the formula the quantifier has moved out of (cf. Heim and Kratzer 1998). Furthermore, it raises a potential syntactic issue in that the movement would have to be countercyclic (Kai von Fintel, p.c.): Aspect moves and then *again* attaches. However, the fact that it may be attached counter-cyclically might in fact justify the position where it does merge. As an adjunct, *again* might be ‘late-merged’ (that is, merged at a point of the derivation where certain covert operations such as LF movement have already taken place). Fox and Nissenbaum (1999) show that adjunct extraposition from NP yields evidence for such a ‘Late Merge’, where QR (a covert operation) can be followed by the late adjunction to the raised NP (an overt operation). If Merging late is indeed an option that the grammar makes available, then it appears that the target for such a merge might in fact be this problematic position (1) (cf. Nissenbaum 2000, a.o.). Thus, assuming that *again* can ‘late-merge’ in this position, we obtain the following (I’m slightly changing the notation from Beck and Johnson (2002) by having the presupposed material between curly brackets):

$$(296) \text{ again}(\lambda e. \text{ marry}(w_1)(e)) = \lambda e. \text{ marry}(w_1)(e) \{ \& \exists e'[e' < e \& \text{ marry}(w_1)(e')] \}$$

Once we combine with Tense and Perfective, we obtain (ignoring the individual argument):

$$(297) \text{ [[Darcy la ha sposare]]} = 1 \text{ iff } \exists e[e \text{ in } w_1 \& \tau(e) \subseteq t \{t < t^*\} \& \text{ marry}(w_1)(e) \{ \& \exists e'[e' < e \& \text{ marry}(w_1)(e')] \}]$$

defined if there is a salient past interval *t* and if there is a marrying event *e'* before *e*. If defined, = 1 iff there is an actual marrying event (by Darcy) contained in *t*.

One further specification is in order. We have seen that an explanation for the actuality entailment pattern required a level of precision that is often glossed over, namely, we need to have Aspect take a world argument in its restriction. Similarly, we need to anchor the presupposed event to a world. I'm thus adding to the presupposition a world anchoring, which obeys the same binding principles (In the above example, this world will be the actual world, as it is bound by the matrix binder):

(298) $\{\exists e'[e' \text{ in } w_1 \ \& \ e' < e \ \& \ \mathbf{marry}(w_1)(e')]\}$.

Now, let's turn to cases involving *volere*. Recall that a sentence like (299), which involves perfective aspect, is infelicitous in a scenario where Darcy and Lizzie never got married before (even if there was a previous *wanting* event). Furthermore, the sentence is compatible with two variants of the previous marrying event scenario: either the previous marrying was wanted, or the previous marrying was unwanted. As we will see, we will get a presupposition of a previous willing marrying event when *again* attaches 'high' and a presupposition of a previous marrying event, unspecified for willingness when it attaches 'low':

(299) Darcy ha voluto sposarla di nuovo.
 Darcy wanted-pfv marry her again

For simplicity, I will ignore individual arguments from now on. Assuming that Perfective moves cyclically, stopping first above the vP and then landing above the ModP, there are two places where *again* can combine with a property of events. The two positions are indicated as 1 and 2 in the tree below:

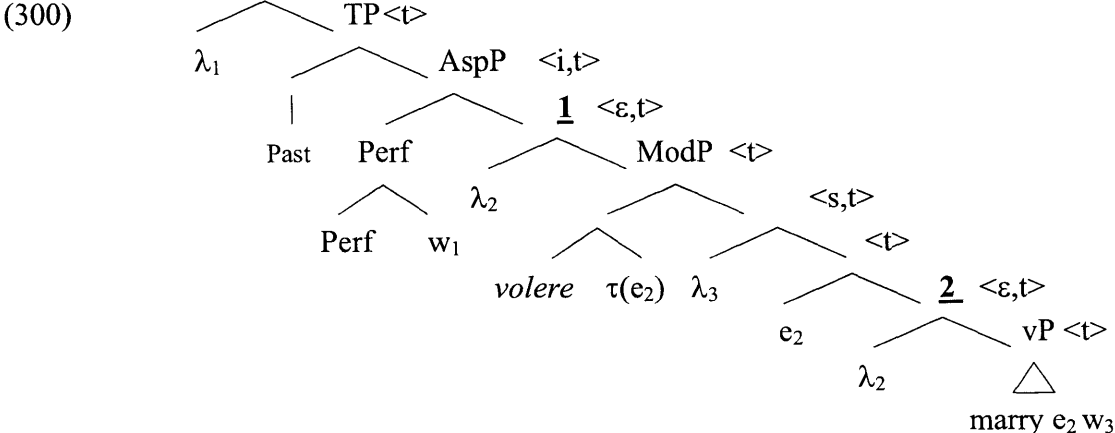

When *again* merges at the lower position (2), we obtain the following (ignoring tense and individuals):

(301) [[Darcy [la ha voluta [sposare di nuovo]]]] = 1 iff [ignoring tense]

Perf ($\lambda e(\mathbf{want})(\lambda w.\mathbf{again}(\lambda e.\mathbf{marry}(w)(e)))$) = 1 iff

$\exists e_2[e_2 \text{ in } w^* \ \& \ \tau(e_2) \subseteq t. \ \forall w \in \text{DES}(s_D, \tau(e_2)):$ **again**($\lambda e.\mathbf{marry}(w)(e_2)$) = 1 iff

$\exists e_2[e_2 \text{ in } w^* \ \& \ \tau(e_2) \subseteq t. \ \forall w \in \text{DES}(s_D, \tau(e_2)):$ **marry**($w)(e_2)$

$\{\& \exists e'[e' \text{ in } w \ \& \ e' < e_2 \ \& \ \mathbf{marry}(w)(e')]\}$ = 1 iff

There is an actual event e_2 at a salient past interval s.t. in all of Darcy's desire worlds w at the time of e_2 , e_2 is a marrying event, and **there is an event e' before e_2 which is a marrying event in all his desire worlds w . Undefined otherwise.**

First, the actuality entailment goes through as per root modals. The event e_2 is a marrying event in all of the worlds in which it occurs, thus it will be a marrying event in the actual world as well, *modulo* issues of event misidentity that arise with a doxastic modal base as with *volere* (cf. chapter 1). The presupposition triggered by *again* is in boldface. It states that in all of Darcy's desire worlds at the time of e_2 , there is an event e' of marrying prior to e_2 . Importantly, this previous marrying event occurs in Darcy's desire worlds at the time of e_2 . Thus, it does not say anything about whether the marriage was something Darcy desired AT the (prior) time of e' : this is the presupposition that we need in contexts where the previous marriage was unwilling.

Note, however, that there is a discrepancy with the intuitions we get. We want there to be an *actual* prior marrying event, not just one in Darcy's desire worlds. The issue will come up again when we discuss the presupposition of a previous marrying event we get with French *want*. As we will see, this has to do with the way presuppositions project in attitude contexts, as was hinted at earlier. What (301), as a whole, will end up presupposing is that Darcy *believes* that he was married to her once before, and in an out of the blue context, we'll take it one step further and assume that, in fact, he has.

Now, let's see what we get when we merge *again* at the highest position (1). This is the presupposition that we need for cases where the *first* marriage was desired:

(302) a. Darcy [[la ha voluta sposare] di nuovo]

b. $\exists e_2[e_2 \text{ in } w^* \ \& \ \tau(e_2) \subseteq t \ \& \ \forall w \in \text{DES}(s_D, \tau(e_2)):$ **marry**(e_2)(w)

$\{\& \exists e'[e' \text{ in } w^* \ \& \ e' < e \ \& \ \forall w \in \text{DES}(s_D, \tau(e')):$ **marry**(w)(e')}

This time we get the presupposition that there is a previous event e' , before e (both in the actual world), which is a marrying event in all of his desire worlds. Here both e' and e_2 are actual events, therefore the same reasoning that gets involved to derive the actuality entailment will also go through for the event of the presupposition: In all worlds in which it occurs, e' is a marrying event; thus, because it occurs in the actual world, it will be a marrying event in the actual world as well.

3.3. FRENCH VS. ITALIAN PERFECTIVE *WANT*

Let's now turn to the presuppositions generated by *again* on *vouloir*. Recall that we should be able to generate a previous *wanting* event (without requiring a previous actual marriage), as well as a (not necessarily desired) previous marriage. When *again* attaches high, we obtain a previous *wanting* event:

- (303) a. Darcy [[a voulu l'épouser] à nouveau]
 b. $\exists s_1[s_1 \text{ in } w^* \ \& \ \tau(s_1) \subseteq t \{t < t^*\} \ \& \ \text{want}(s_1) \ \& \ \forall w \in \text{DES}(s_1): \exists e_2[e_2 \text{ in } w \ \& \ \tau(e_2) \subseteq \tau(s_1) \ \& \ \text{marry}(e_2, w) \ \& \ \exists s_3[s_3 \text{ in } w^* \ \& \ s_3 < s_1 \ \& \ \text{want}(s_3) \ \& \ \forall w \in \text{DES}(s_3): \exists e_4[e_4 \text{ in } w \ \& \ \text{marry}(e_4, w)]]$

The presupposition states that there is a previous '*wanting that there is a marrying event*' state. This presupposition doesn't force an *actual* marrying event, given that the event argument of *marrying* is bound in Jean's desire worlds. The reasoning about event identification across worlds is unavailable in the presupposition, as it is in the asserted sentence, given that the event in the matrix is not the same as the one in the complement.

When we attach *again* 'low', that is, at the embedded vP level, we generate the presupposition that there is a previous marrying event e_3 in all of Jean's desire/belief worlds at the time of s_1 . Importantly, his desires at the time of s_1 may be different than his desires at s_3 , thus the previous marriage may have been undesired:

- (304) a. Darcy [a voulu [l'épouser à nouveau]]
 b. $\exists s_1[s_1 \text{ in } w^* \ \& \ \tau(s_1) \subseteq t \{t < t^*\} \ \& \ \text{want}(s_1) \ \& \ \forall w \in \text{DES}(s_1): \exists e_2[e_2 \text{ in } w \ \& \ \tau(e_2) \subseteq \tau(s_1) \ \& \ \text{marry}(e_2, w) \ \& \ \exists e_3[e_3 \text{ in } w \ \& \ e_3 < e_2 \ \& \ \text{marry}(e_3, w)]]$

Recall that the presupposition that we are supposed to generate, according to Wurmbrand, is that there is an *actual* previous marrying event, which may not have been desired. This is not

what we obtain directly. As hinted above, this has to do with presupposition projection in attitude contexts. In our case, the complement presupposes that there is a previous marrying event (because of the presupposition trigger *again*) in all of Darcy's desire/belief worlds: this previous marrying event doesn't have to hold in the actual world. However, Darcy has to *believe* that there was a previous marrying event. Why is it that we feel that (304) presupposes that there was an (actual) marrying event? For the same reason that, out of the blue, we feel that (305)a) presupposes that Patrick owns a cello. If we precede (304) with a statement that makes it clear that Darcy is under the misconception that he got married to Lizzie once before, the presupposition of an actual previous marriage disappears:

- (305) a. Patrick wants to sell his cello.
- b. Darcy is under the misconception that he married Lizzie before, and he wants to marry her again.

Thus, a sentence like (304) is compatible with Wurmbrand (1998)'s scenario in which Darcy married Lizzie at a time prior to the time of his wanting (even if he didn't want to marry her then). The presupposition we generate is that Darcy *believes* that there was a previous marrying event. We will tend to interpret this presupposition as a presupposition that there was a previous marrying event for the same reasons we tend to accommodate that Patrick owns a cello (rather than he believes he does), when the sentence '*Patrick wants to sell his cello*' is uttered out of the blue. As Heim (1992) suggests, one possible reason underlying this 'hole'-like behavior of attitude predicates could have to do with the nature of presupposition accommodation: we should really accommodate only things that are uncontroversial and unsurprising (leaving the surprise and controversy for assertions). When a sentence like (305)a) is uttered out of the blue, the hearer has to accommodate that Patrick believes that he owns a cello. The most uneventful way to do so is to assume that, in fact, Patrick owns a cello. This option could also work in our examples as well. Why would Darcy have the belief that he was married once before? The easiest, most normal reason why he should have such a belief is because, in fact, he did get married then⁸¹.

⁸¹ Another option presented in Heim (1992) is that the hole-like behavior of attitudes results from "*de re* construals of (a constituent containing) the presupposition trigger" (Heim 1992: 207). We interpret 'his cello' *de re*, which essentially amounts to moving it outside of the scope of *want*. Unsurprisingly then, the presupposition triggered by the definite description will have to be entailed by the larger context. One difficulty that Heim notes is how to extend a *de re* approach to all cases of presupposition projections which do not involve DPs. It remains to be seen

3.4. IMPERFECTIVE *VOLERE*, AGAIN.

We now need to make sure that we get the correct presuppositions when *volere* has imperfective aspect. I assume that the reading of the imperfective here is the counterfactual one. First let's derive the presupposition when *again* attaches low:

- (306) a. Darcy [la voleva [[sposare] di nuovo]]
 b. $\forall w' \in \text{Acc}_{\text{MET}}(w^*): \exists t' \ \& \ t' = [t, \infty) \ \{t < t^*\}: \exists e[e \text{ in } w' \ \& \ \tau(e) \subseteq t' \ \& \ \forall w'' \in \text{DES}(S_{D, \tau(e)}): \text{marry}(e, w'')] \ \{\& \ \exists e'[e' \text{ in } w'' \ \& \ e' < e \ \& \ \text{marry}(e', w'')]\}$

Note in passing that we do not get an actuality entailment, as the event is not bound in the actual world, but in all metaphysically accessible worlds, in which, presumably, a covert *if*-clause holds (*if he could, he would want to marry her again*). Thus, while the actual world is one of the metaphysically accessible worlds, it still might not be one of the worlds in which the restriction provided by the *if*-clause holds, hence we do not get an actuality entailment. We generate the presupposition that there is a previous marrying event in all of Darcy's desire/belief worlds; again, Darcy has to believe that there was a previous marrying event and again, we will accommodate that the reason why he holds such a belief is that he in fact did get married.

When *again* attaches high, we get:

- (307) a. Darcy [[la voleva sposare] di nuovo]
 b. $\forall w' \in \text{Acc}_{\text{MET}}(w^*): \exists t' \ \& \ t' = [t, \infty) \ \{t < t^*\}: \exists e[e \text{ in } w' \ \& \ \tau(e) \subseteq t' \ \& \ \forall w'' \in \text{DES}(S_{D, \tau(e)}): \text{marry}(e, w'')] \ \{\& \ \exists e'[e' \text{ in } w' \ \& \ e' < e \ \& \ \forall w'' \in \text{DES}(S_{D, \tau(e')})]: \text{marry}(e', w'')\}$

This won't force an actual marrying event, again because the value of the world variable on the matrix event is not the actual world (*contra* the cases where *again* merges high on *volere* with *perfective* aspect). The event that is presupposed will be the same sort of event that the one which is asserted, that is, a counterfactual event.

To sum up, with *volere* and perfective aspect, we presuppose a previous marrying event, both when *again* attaches high, and when it attaches low. On the other hand, *volere* and imperfective aspect, we do not get a previous *wanting* event, because the event is anchored in a counterfactual world. In French, we get both kinds of presuppositions, regardless of aspect. What allows a previous *wanting* event, is different than in the case of imperfective on *volere*: in

whether, some of the less straightforward *de re* construals might be done in terms of interpreting *events de re*, now that we have enriched the ontology as to include events.

French, the aspect of the complement clause cannot move to the matrix, hence, the event that happens in the actual world is simply a *wanting to get married* event.

4. CONCLUSION

To sum up, French *vouloir* and Italian *volere* differ structurally in that the latter, allows perfective aspect in the complement to move above the modal element, in true root modal fashion, thus yielding an actual event. This movement is made possible because (i) *volere* doesn't have its own event argument; (ii) its complement is syntactically transparent and allows such movement. I have tried to relate this violation of locality effect to the clause transparency effects associated with Restructuring. As a Restructuring Verb, *volere* will only take complements that allow such locality violations: either a bare infinitival or a CP complement with subjunctive. As we saw, we do not find a one to one correspondence between Aspect movement (actuality entailment) and clitic climbing; thus the two phenomena seem to be sensitive to different locality requirements. French *want* on the other hand is not a RV, and thus doesn't allow clitic or aspect movement across a clause boundary. This difference between the two languages explains the otherwise puzzling presuppositions (or rather, lack of) generated with *again*. Furthermore, the data reviewed shed some light on the debate on the number of events involved with a Restructuring Verb. The complements of *volere* (CP with subjunctive or bare infinitivals) do not have their own Aspect quantifier, independent of the matrix: thus, we have a single *event quantifier*, but two *event descriptions*.

CONCLUSION

In this dissertation, I have tried to show that a unified analysis of modal auxiliaries is attainable, despite the syntactic and semantic differences that seem to set their various interpretations apart. As in many languages, modal auxiliaries in French and Italian can receive various interpretations: epistemic, deontic, ability, circumstantial, goal-oriented... In a Kratzerian semantics (cf. Kratzer 1981, 1991), this variability is captured via ‘conversational backgrounds’, that is, functions provided by the context, which restrict the set of worlds quantified by the modal to those in which the laws are obeyed, or those in which certain facts of the worlds hold, etc. As we saw in chapter 3, a problem with such a view is that it doesn’t readily explain why the range of interpretations that these modals get is constrained in systematic ways. In particular, the modality seems to always be anchored not just to world, but to an individual and a time as well. However, not all time-individual pairs are attested: when a modal is speaker-oriented (as is the case for epistemics), or addressee-oriented (as in the case of true deontics), it is anchored to the time of utterance, but not the time provided by Tense. When the modal is subject-oriented (as is often the case with circumstantials: abilities, goal-oriented, subject-oriented deontics), it is anchored to the time provided by Tense (and not the utterance time). The following example illustrates:

- (308) Jane a dû prendre le train.
Jane must-pst-pfv take the train
Epistemic: According to **my** evidence **now** it must be that Jane took the train.
*According to **my** evidence **then** Jane had to take the train.
Goal-oriented: Given **Jane**’s circumstances **then** she had to take the train.
*Given **Jane**’s circumstances **now** she had to take the train.

If the variability in modal interpretation is to be derived solely by context, these time-individual pair restrictions seem puzzling.

We further saw evidence that epistemic/true deontics tend to scope high, while roots tend to scope low: epistemics/deontics are interpreted above Tense, and above a quantifier in subject position, while roots are interpreted below Tense, and do not seem to allow reconstruction of the subject. We added to the stack of these height differences the ‘actuality entailment’ puzzle, which shows that Aspect interacts differently with the various interpretations of the modal auxiliaries. As we saw, only when a modal has a circumstantial accessibility relation does it yield

what Bhatt (1999) called an ‘actuality entailment’, that is, an inference that the proposition expressed by the complement holds in the actual world, which arises when the modal has perfective, but not imperfective aspect. We saw that, on the other hand, epistemic and true (i.e., addressee-oriented) deontic interpretations were immune to actuality entailments, as they seemed to be interpreted above Aspect.

Thus, on the one hand, we have the cross linguistic tendency to use the same words to express possibility and necessity, which favor a unified treatment of modal auxiliaries à la Kratzer where these various interpretations share a common lexical entry. On the other hand, their interaction with Tense, Aspect, and quantifiers seem to point to (at least) two separate entries: a ‘high’ position for epistemic modals, and a low position for root modals. The goal of this dissertation was to show that a unified account was attainable, which would reduce the problem of ‘height’ of interpretation to standard syntactic principles of binding and locality. To do so, I proposed the following assumptions:

1. Modals are not predicates of events (verbs): they are functional heads, which can either be merged above or below Tense. They take a proposition as a complement and return a proposition.
2. A modal’s accessibility relation relates a set of worlds to an event, rather than to a world (as is standardly assumed): all accessibility relations have an event pronoun which needs to be bound by the closest binder possible.
3. Possible event binders are attitude verbs, the speech event, and Aspect.
4. (Perfective) Aspect is a quantifier over events, which gets base-generated as an argument of the verb and has to move to a position right below Tense for type-reasons (in an analogous way to quantifiers over individuals in object position).
5. If a Modal is merged below Tense, Aspect will have to move above that modal, in order to combine with its time argument in Tense.

Given these assumptions, we obtain the following binding possibilities:

(309)	e_{speech}^*	(Att ₂)		T	Asp ₁	Mod _{f(e1)}	V	e_1
	e_{speech}^*	Att ₂	Mod _{f(e2)}	T	Asp ₁		V	e_1
	e_{speech}^*		Mod _{f(e*)}	T	Asp ₁		V	e_1

Thus a modal is either relativized to the speech event, an attitude event, or the event quantified by Aspect. In the next three sections, I briefly review what we derived from these assumptions.

1. RELATIVIZATION OF THE MODAL TO AN EVENT

Relativizing the modality to an event gets us the right time and individual pairings: if a modal's time of evaluation is the utterance time (temporal trace of the speech event), then it will either be speaker or addressee oriented (the participants of the speech event). If a modal's time of evaluation is the internal now of the embedding attitude, it will be attitude holder oriented (the experiencer of the attitude event). If a modal's time of evaluation is that provided by Tense (temporal trace of the event quantified by Aspect), it will be subject/location-oriented (participants of the event quantified over by Aspect).

In chapter 3, I further attempted to explain why a speech-bound modal gets an epistemic or a deontic accessibility relation, and why an Aspect-bound modal gets a circumstantial accessibility relation. I proposed that the accessibility relations have selectional restrictions on the type of event that can bind them. We ended up with the following three accessibility relations:

- (310) a. $f_{\text{EPISTEMIC}}(e) = \lambda e.\lambda w. w$ is compatible with $\text{CON}(e)$
 b. $f_{\text{CIRC}}(e) = \lambda e.\lambda w. w$ is compatible with circumstances of e
 c. $f_{\text{DEONTIC}}(e) = \lambda e.\lambda w. w$ is compatible with $\text{TO-DO LIST}(\text{ADDR}(e))$.

An epistemic relation requires an event binder with content, a deontic relation requires an event binder with an addressee, which in turns has a To-Do List (cf. Portner 2001, Ninan 2005).

Epistemics

The event argument of an epistemic relation has to be bound by an event that has CONTENT. The only possible binders are then attitude predicates and the speech event. The 'content' of an attitude will be the set of propositions that make up this attitude: e.g., the content of a belief state is the set of beliefs that the state's experiencer has. The following example illustrates:

- (311) a. Darcy believes that it might be raining.
 b. [_{cp} e* T Asp₁ believe s₁ [_{cp} might f(s₁) T Asp₂ raining e₂]]
 c. $\exists s[s \text{ in } w^* \ \& \ \tau(s) \supseteq t^* \ \& \ \text{Exp}(s,D.) \ \& \ \text{believe}(s) \ \& \ \forall w' \in \text{CON}(s): \exists w'' \in \text{CON}(s): \text{it is raining at } \tau(s) \text{ in } w'']$

We observed that in cases where an attitude took a complement with an epistemic modal, as in (311), the attitude verb quantified vacuously: this was due to the fact that I took both attitudes and modals to be relativized to a state, rather than a world. The primary role that an attitude performs in a sentence like (311) then, is to provide a state with content that can bind the event argument of the modal's accessibility relation, and thereby relativize the modal to the epistemic state of the attitude holder at the attitude time.

believe is able to bind the epistemic relation, because it has content. I also speculated that the speech event has content, by which I meant that it was able to access the set of beliefs of the speaker. Thus, in unembedded cases, where the closest binder is the speech event (i.e., the modal is above Aspect), it will be bound by this speech event, which will be able to bind an epistemic accessibility relation.

When a modal is merged below Tense, and Aspect is thus the closest binder, it won't be able to yield an epistemic relation (unless the event quantified by Aspect is itself an attitude): hence such a modal will have to get a circumstantial accessibility relation.

Deontics

A deontic accessibility relation will only be available when the event that binds it has an addressee. Most cases will thus involve a modal bound by the speech event (and hence, merged above Tense):

- (312) a. Lydia must go to confession.
 b. [_{cp} e* must f(e*) T Asp₂ Lydia go to confession e₂]]
 c. $\forall w' \in (\text{TO-DO LIST}(\text{ADDR.}(e^*)))$: Lydia goes to confession in w'

The other environment where a deontic accessibility relation will appear will be when embedded under an attitude which reports a speech act, and where an (implicit) addressee can be extracted, as in '*Jane said (to someone) that Lydia must go to confession*'.

Circumstantial

We saw that a circumstantial accessibility relation provided a set of worlds in which the permanent properties of the event's participants relevant for the event to take place were kept constant. This accessibility relation was mostly used for Aspect-bound modals, which cannot get an epistemic nor a deontic relation:

- (313) a. Jane a pu courir
Jane could-pfv run
b. $[_{cp} e^* \quad T \quad \mathbf{Asp}_1 \quad \text{Mod } f(e_1) \quad V \quad e_1$
c. $\exists e[e \text{ in } w^* \ \& \ \tau(e) \subseteq t \ \& \ \exists w' \in \text{CIRC}(e): \text{run}(e, w') \ \& \ \text{Ag}(e, J).$

This configuration was precisely that which yielded actuality entailments.

2. ACTUALITY ENTAILMENTS AND ROOT MODALS

We saw that when Aspect was above a modal, it could yield an actuality entailment. This happened when Aspect moved out of its base position as an argument of the verb, to a position right under Tense (for type reasons), moving above a modal that would have been merged below Tense, as was the case with perfective aspect. This movement resulted in the modal's own world argument not being in the scope of the modal anymore, but rather, having to be bound by the matrix default world binder (Percus 2000). This yielded an actual event:

- (314) a. Jane a pu courir un marathon.
Jane could-pfv run a marathon
b. $[_{cp} \lambda w^* \quad T \quad \mathbf{Asp}_1(w^*) \quad \text{Mod } f(e_1) \quad V \quad e_1$
c. $\exists e[e \text{ in } w^* \ \& \ \tau(e) \subseteq t \ \& \ \{t < t^*\} \ \& \ \exists w' \in \text{CIRC}(e): \text{run}(e, w') \ \& \ \text{Ag}(e, J).$

We obtain that 'an actual event happened, which in *some* world compatible with the circumstances of the event, was a running event by Jane'. We are then able to infer that, given that this event is a running event in some world, it has to be a running event in all of the worlds in which it occurs, *ceteris paribus*, based on a principle of event identification across worlds. Or, in other words, we get an actuality entailment.

Chapter 2 was devoted to the imperfective and to showing that the lack of actuality entailments with imperfective on a root modal resulted from the presence of an additional modal element (besides the modal itself), reflected by imperfective morphology. We saw that

imperfective on a root modal yielded two kinds of readings: a long-term ability/disposition, which we found resulted from the presence of a generic operator; and a counterfactual reading, which I argued resulted from the presence of a primitive counterfactual modal. We saw that, independently, the imperfective had these two modal usages, and thus were able to derive a lack of actuality entailments with roots. The following example illustrates with a generic operator (GEN). This GEN quantifies over normal/ideal events which, in some circumstantially-accessible world, are events of running:

- (315) a. Jane pouvait courir un marathon.
Jane could-impf run a marthon.
- b. $[_{cp} \lambda w^* \quad T \quad \text{GEN}_1 \text{ Mod } f(e_1) \quad V \quad e_1$
- c. $\forall e_1 \in f_{\text{nor}}(t, w): \text{precond.-for-J.'s-run-hold}(e_1): \exists w_4 \in \text{CIRC}(e_1): \text{run}(e_1, w_4) \ \& \ \text{Ag}(e, J.)$

The lack of entailment arises from quantifying over these idealized events, which may or may not occur in the actual world.

3. ITALIAN VS. FRENCH *WANT*

The last chapter was devoted to the difference between Italian and French *want*. We saw that, surprisingly, the former yielded actuality entailments with perfective, while the latter didn't:

- (316) a. Lizzie a voulu parler à Darcy, mais elle ne lui a pas parlé.
b. Lizzie ha voluto parlare a Darcy, #ma non gli ha parlato.
Lizzie wanted-pfv talk to Darcy, (#)but she didn't talk to him

We treated Italian *volere* as an attitude-modal hybrid, which, like an attitude verb has a fixed accessibility relation which picks the most desirable worlds among the subject's belief worlds. Like a modal however, it differs from its French/English counterpart by not taking an event argument (other than the event variable inside its restriction). Thus, it allows Aspect base-generated in its complement to raise above it, to a position right below T, in the matrix. This yields an actual event, which, in all most desirable worlds among those compatible with the belief state of the subject (Lizzie), was an event of talking to Darcy. Again, because of the principle of event identification across worlds, we infer that this actual event was an event of talking to Darcy.

4. FURTHER ISSUES

We thus saw that a few assumptions about Aspect and modals enabled us to (a) maintain a unified analysis of modal auxiliaries and (b) derive actuality entailments when Aspect and the modal were in a particular configuration. Many questions remain. Here are some, to name a few. It still remains unclear why it is that a progressive cannot move on top of a root modal. I also left unresolved issues associated with the Perfect. Where does it fit? And what explains why it requires perfective morphology in French and Italian, but not, say, in Greek?

Another area which deserves further attention is attitude verbs. I have introduced a new machinery to incorporate events into their semantics. The question becomes whether dealing with an event with content can handle all of the cases usually handled with individual-time-world triplets. *de se* ascriptions immediately come to mind. I have also only sketched an account of the speech event. What exactly is this event? Does it have to be represented in the syntax? Can we get rid of some of the redundancy of have both a default world binder, and a speech event?

While I have focused on the main uses of modal auxiliaries (epistemic, deontic, circumstantial), I have ignored semi modals, such as *to be able*, or *to be allowed*. I have also avoided cases where modal auxiliaries seems to perform a role similar to a Generic Operator, and seem to bind individual variables (cf. Heim 1982; Brennan 1993):

(317) Texans can be tall \approx *some* Texans are tall

Does this proposal hold when we look at the cross-linguistic picture? The prediction is that, as long as a language shows an overt perfective/imperfective distinction, we should get actuality entailment with perfective. However, perfective on a root modal in Spanish yields an additional counterfactual reading. Thus, the morphological spell out conditions offered in chapter 2 cannot be straightforwardly extended to Spanish. What underlies these morphological differences remains an open question. I have also avoided Balkan languages, such as Greek, where aspect morphology appears both on the modal and on its infinitival complements. What matters for the actuality entailments in these cases is the aspect on the matrix. However, different aspects on the infinitive itself yield different meanings:

- (318) a. Borese na fεvgi [S. Iatridou, p.c.]
 He could-pfv na leave-impf
 'He was able to go out (regularly)'
- b. Borese na fiyi
 He could-pfv na leave-pfv
 'He was able to leave (this one time)'

Is this data compatible with the current proposal, in which Aspect originates in the complement clause and moves up to the matrix Tense? If so, what would be the aspect in the complement clause? This data suggests a more complex event structure in the complement. Hopefully, we could still have perfective originate in the embedded clause: it would quantify over a mega event (itself containing either a plural (habitual) event or a punctual event). We would get the following truth conditions: *there is a mega-event in the actual world, which in some accessible world is composed of a plural event of leaving*. Interestingly, it seems that the infinitivals in the above examples cannot carry their own tense (the time of the embedded complement cannot be past-shifted w.r.t. matrix time) (cf. Iatridou 1988). This fact supports my proposal: the mega-aspect not being able to get its time argument in the complement would have to move up to the matrix T, and would thus be forced to take the actual world as its world argument, yielding an actual mega event. Aspect in Balkan languages is a complex issue; I thus leave a precise analysis of actuality entailments in these languages for future research.

I would like to end this dissertation with a promissory note. From root modals and Italian *volere*, I have argued that the recipe for actuality entailments is to have a single quantifier over events bind the event variable of the complement from a point *above* the modal element. I would like to show that this recipe might explain all cases where a (c)overtly modalized construction yields actuality entailments with perfective only, and set them apart from closely related constructions which do not.

5. THE BIG PICTURE

We saw in chapter 1 that a certain configuration between a modal and perfective aspect yields actuality entailments. This result relied on two assumptions: (i) Aspects (i.e., quantifiers over events) have a world argument, and when the aspect is perfective and is in matrix context (i.e., when it moves above a root modal), its world argument will be the actual world, thereby yielding an actual event; (ii) we can identify events across worlds via a set of essential properties. We saw

in chapter 2 that the reason that imperfective doesn't force actuality entailments is that it reflects an additional layer of modality, which prevents the event from being anchored in the actual world. Is this a particular property of modal auxiliaries or could it be extended to other constructions?

As it turns out, the actuality entailment/perfective aspect pattern occurs in a series of covertly or overtly modalized constructions, which, at first blush, do not seem to form a natural class. For convenience, I will refer to this 'class' of constructions as PERFECTIVE IMPLICATIVES (PERFIMP) as they behave like implicative predicates (such as *manage*), but only with perfective aspect. I would like to suggest that there is a common element to all PERFIMPS: they describe a *single* event. Or, in other words, yielding an actuality entailment with perfective only is symptomatic of a single quantification over events. Thus the mechanism underlying the actuality entailment pattern will be their ability to have a single quantifier over events above their modal element and binding the event variable in their complement, as schematized below:

(319) $\exists e_1 \quad \text{MOD} \quad V(e_1)$

First are *Too* and *Enough* constructions. As the examples below show, with perfective morphology, an *enough* construction entails that the complement took place in the actual world, but this actuality entailment disappears with imperfective. Similarly, a *too* construction entails that its complement did **not** take place with perfective, but not with imperfective aspect (cf. Hacquard, 2005):

- (320) a. Jane a été assez rapide pour s'enfuir, #mais elle ne s'est pas enfuie.
 Jane was-pfv quick enough to escape, #but she didn't escape
 b. Jane était assez rapide pour s'enfuir, mais elle ne s'est pas enfuie.
 Jane was-impf quick enough to escape, but she didn't escape
- (321) a. Jane a été trop lente pour s'enfuir, #mais elle s'est quand même enfuie.
 Jane was-pfv too slow to escape, #but she still escaped
 b. Jane était trop lente pour s'enfuir, ?mais elle s'est quand même enfuie.
 Jane was-impf too slow to escape, ?but she still escaped

However, certain instances of *too* and *enough* constructions do not force actuality entailments, namely their attributive uses. In the sentence below, the continuation negates the complement clause, and yet the sentence as a whole is not a contradiction⁸²:

- (322) Bingley a acheté assez de bois pour chauffer sa maison, mais il y a fait froid tout l'hiver, vu qu'il était trop occupé pour faire un feu.
Bingley bought-pfv enough wood to heat his house, but it was cold there all winter long, since he was too busy to make a fire.

Once we start thinking in terms of number of event quantifications, we observe that, while it is conceivable and even unavoidable to understand sentences (320) and (321) as describing a single event (each), namely an event of escaping (contingent on speed), this cannot be the case for (322): an event of *buying wood* cannot be the same as an event of *heating one's house*.⁸³

Another PERFIMP briefly mentioned in chapter 1 was the *enabling* reading of *permit*, which we contrasted to its *grant permission* reading. Only the former yielded actuality entailments:

- (323) a. La mère de Jane lui a permis de passer la nuit chez les Bingleys, mais elle est quand même rentrée chez elle.
Jane's mother permitted-pfv her to spend the night at the Bingleys, but she came home anyway.
- b. L'orage lui a permis de passer la nuit chez les Bingleys, #mais elle est quand même rentrée chez elle.
The storm permitted-pfv her to spend the night at the Bingleys, #but she came home anyway.

Again, once we start counting events, we can see that we are dealing with a single event with the *enabling* reading, namely an event of *spending the night at the Bingleys (thanks to the storm)*. With a *grant permission* reading, we simply cannot conceive of a *granting permission* being the same event as a *spending the night* event.

⁸² I'm indebted to both Gennaro Chierchia and Roumyana Pancheva, p.c., for pointing this fact out to me.

⁸³ Relating the proposal I offered in Hacquard (2005) to the current proposal is beyond the scope of this dissertation. The hope is that the two will be reconcilable, once I incorporate events in my old proposal, and let the attributive uses get an extra layer of event quantification (which could e.g., involve a GEN).

Finally, there is a series of *have the NP to* constructions, which vary in implicative behavior. The one in (a) is implicative only with perfective aspect, the one in (b) is never implicative, and the one in (c) is always implicative (even with imperfective aspect):

- (324) a. Jane a eu le courage de parler à Bingley, #mais elle ne lui a pas parlé.
Jane had-pfv the courage to talk to Bingley, #but she didn't talk to him
- b. Jane a eu la permission de parler à Bingley, mais elle ne lui a pas parlé.
Jane had-pfv the permission to talk to Bingley, but she didn't talk to him
- c. Jane avait l'occasion de parler à Bingley, #mais elle ne lui parlait pas.
Jane had-impf the opportunity to talk to Bingley, but she wouldn't talk to him.

Putting the real implicative in (c) aside (whose analysis will be amenable to that of classic implicatives like *manage*, cf. Karttunen 1971), we can, again, conceive of (a) involving a single (courageous) event, but the one in (b) as two events, as in the *grant permission* reading of *permit*.

While a detailed account of each of these constructions is beyond the scope of this work, this brief survey points to a possible underlying mechanism for yielding actuality entailments with perfective aspect. The key to the actuality entailment pattern would not be so much about sharing the same modal flavor: for instance *volere* has an epistemic modal base, further restricted by a bouletic ordering source, while root modals have a circumstantial modal base. Instead, the crucial ingredient common to all PERFIMPS would be their ability to allow a single quantification over events. In PERFIMPS, the event quantifier could move above their modal element (thus out of its scope), and thus yield an actual event. The extra modal elements associated with imperfective morphology would be responsible for their non implicative readings.

We saw closely related constructions to each of these PERFIMPS, which despite their closeness in meaning were not sensitive to aspect and did not force actuality entailments: the *give permission* reading of *permit* (vs. its *enable* reading); the attributive uses of *too* and *enough* (vs. its predicative uses); the *have the desire/permission to* (vs. *have the courage to...*). This fact is strangely reminiscent of the *avere voglia* vs. *volere*, and the *have the possibility* vs. *pouvoir/potere* contrasts, and suggests that the ultimate solution to the actuality entailment puzzle is rooted into the syntax and semantics of both Aspect and each of the PERFIMPS, rather than being a pragmatics-bound phenomenon, as I have argued in this dissertation was the case for modal auxiliaries in French and Italian.

BIBLIOGRAPHY

- Abrusan, M.: 2005, 'Rules of Particle Climbing in Hungarian', ms., Massachusetts Institute of Technology.
- Abusch, D.: 1997, 'Sequence of Tense and Temporal *de re*'. *Linguistics and Philosophy* 20-1.
- Abusch, D.: 2006, 'Some Puzzles on Modality and Tense', paper presented at Tübingen Colloquium, handout.
- Ambar, M.: 1999, 'Aspects of Focus in Portuguese', in L. Tuller and G. Rebuschi (eds.) *The Grammar of Focus*. John Benjamins.
- Anderson, A. R.: 1951, 'A note of Subjunctive and Counterfactual Conditionals'. *Analysis* 12, 35-38.
- Arregui, A.: 2005, *On the Accessibility of Possible Worlds: The Role of Tense and Aspect*. Ph.D. Thesis, University of Massachusetts, Amherst.
- Bonomi, A.: 1997, 'Aspect, Quantification and when-clauses in Italian'. *Linguistics and Philosophy* 20, 469-514.
- Beck, S. and K. Johnson: 2004, 'Double Objects Again'. *Linguistic Inquiry* 35, 97-124.
- Beghelli, F. and T. Stowell: 1997, 'Distributivity and Negation: The syntax of *each* and *every*', in A. Szabolcsi (ed.) *Ways of scope taking*. Dordrecht: Kluwer.
- Bhatt, R.: 1998, 'Obligation and Possession', in H. Harley (ed.) *Papers from the UPenn/MIT Roundtable on Argument Structure and Aspect, MITWPL 32*. Cambridge, MA: MITWPL.
- Bhatt, R.: 1999, *Covert Modality in Non-Finite Contexts*. Ph.D. Thesis, University of Pennsylvania.
- Bhatt, R. and R. Pancheva: 2005, Aspect. *LSA Summer Institute*, class notes.
- Boogart, R.: 2004, 'Temporal relations in modal constructions', paper presented at *Chronos 6*, Geneva.
- Brennan, V.: 1993, Root and Epistemic modal auxiliary verbs, Ph.D. Thesis, University of Massachusetts, Amherst.
- Bródy, M.: 1999, 'Word order, restructuring and mirror theory', ms. UCL/HAS.
- Brogonovo, C. and S. Cummins: 2006, 'Past-Tense Modals in Spanish and French', paper presented at the 16e Coloquio de Gramática Generativa, Madrid, handout.

- Butler, J.: 2003, 'A Minimalist Treatment of Modality'. *Lingua* **113**, 967-996.
- Butler, J.: 2005a, 'The Phase Structure of Tense', in M. McGinnis and N. Richards (eds.) *Perspectives on Phases. MITWPL* 49. Cambridge, MA: MITWPL.
- Butler, J.: 2005b, 'What semantic concerns can tell us about syntactic structure', ms., Universität Stuttgart.
- Carlson, G., N.: 1977, *Reference to Kinds in English*. Ph.D. Thesis, University of Massachusetts, Amherst.
- Chierchia, G.: 1995, 'Individual-level predicates as Inherent Generics', in G. N. Carlson & F. J. Pelletier (eds.) *The Generic Book*, Chicago: The University of Chicago Press.
- Chisholm, R. M.: 2002, 'Identity through Time', in Kim and Sosa (eds.) *Metaphysics, An Anthology*. Blackwell.
- Cinque, G.: 1999, *Adverbs and Functional Heads: A Cross-Linguistic Perspective*, Oxford Studies in Comparative Syntax. Oxford and New York: Oxford University Press.
- Cipria, A. and C. Roberts: 2000, 'Spanish *Imperfecto* and *Preterito*: Truth Conditions and Aktionsart Effects in Situation Semantics'. *Natural Language Semantics* **8**.
- Condoravdi, C.: 2001, 'Temporal Interpretations of modals', in D. Beaver, S. Kaufman, B. Clark (eds.) *Stanford Papers in Semantics*. Palo Alto: CSLI Publications.
- Copley, B.: 2002, *The semantics of the Future*. Ph.D. Thesis, Massachusetts Institute of Technology.
- Dahl, O.: 1975, 'On Generics', in E. Keenan (ed.) *Formal Semantics of Natural Language*. Cambridge: Cambridge University Press.
- Davidson, D.: 1967, 'The Logical Form of Action Sentences', in N. Rescher (ed.) *The Logic of Decision and Action*. Pittsburg: University of Pittsburg Press, 81-120.
- DeRose, K.: 1991, 'Epistemic Possibilities'. *The Philosophical Review*, Vol. C, No. 4.
- Dowty, D.: 1977, "Towards a semantic analysis of verb aspect and the English 'imperfective' progressive". *Linguistics and Philosophy*, **1**, 45-77.
- Dowty, D.: 1979, *Word Meaning and Montague Grammar*. Dordrecht: Reidel.
- Drubig, H. B.: 2001, 'On the syntactic form of epistemic modality', ms. Available at <http://www.sfb441.uni-tuebingende/b2.papers/DrubigModality.pdf>.

- Egan, A., J. Hawthorne, and B. Weatherson: 2004, 'Epistemic Modals in Context', in G. Preyer and G. Peter (eds.) *Contextualism in Philosophy*. Oxford: Oxford University Press.
- É. Kiss, K.: 1999, 'Strategies of verbal complex formation and the Hungarian verbal complex', in I. Kenesei (ed.) *Crossing boundaries*. John Benjamins, 91-114.
- Fabricius-Hansen, C.: 2001, 'Wi(e)der and again(st)', in C. Féry and W. Sternefeld (eds.) *Auditor vox sapientiae: a festschrift for Arnim for Stechow*. Berlin: Akademie Verlag, 101-130.
- Farkas, D.: 1992, 'On the Semantics of Subjunctive Complements', in P. Hirschbühler (ed.), *Romance Languages and Modern Linguistic Theory*. John Benjamins, pp. 69-105.
- Ferreira, M.: 2004, 'Imperfectives and Plurality', in R. Young (ed.) *Proceedings of SALT XIV*, Ithaca, NY: Cornell University.
- Ferreira, M.: 2005, *Event Quantification and Plurality*. Ph.D. Thesis, Massachusetts Institute of Technology.
- Feldman, F.: 1986, *Doing the Best We Can*. Dordrecht: Reidel.
- von Fintel, K.: 1997. 'Bare Plurals, Bare Conditionals, and Only'. *Journal of Semantics* 14, 1-56.
- von Fintel, K.: 1999. 'NPI-Licensing, Strawson-Entailment, and Context-Dependency'. *Journal of Semantics* 16.1.
- von Fintel, K.: 2001, *Advanced Semantics Seminar*, lecture notes, MIT.
- von Fintel, K., and A. S. Gillies: 2006, 'CIA Leaks. Pacific APA, 2006'. First Draft, May 16, 2006. Available at: http://mit.edu/fintel/www/cia_leaks.pdf
- von Fintel, K., and I. Heim: 2002, 'Lecture Notes on Intensional Semantics', ms., Massachusetts Institute of Technology.
- von Fintel, K. and S. Iatridou: 2003, 'Epistemic Containment'. *Linguistic Inquiry* 34, 173-198.
- von Fintel, K. and S. Iatridou: 2004a, 'What to do if you want to go to Harlem: Notes on Anankastic Conditionals and Related Matters', ms., Massachusetts Institute of Technology, available at: <http://web.mit.edu/fintel/www/harlem.pdf>
- von Fintel, K. and S. Iatridou: 2004b, *Seminar on Modality*, lecture notes, Massachusetts Institute of Technology.
- von Fintel, K. and S. Iatridou: 2005, 'Anatomy of a Modal', in J. Gajewski, V. Hacquard, B. Nickel and S. Yalcin (eds.) *New Work on Modality, MITWPL 51*. Cambridge, MA: MITWPL.

- Fox, D. and J. Nissenbaum: 1999, 'Extraposition and Scope: A Case for overt QR', in *Proceedings of WCCFL 18*.
- Giorgi, F. and A. Pianesi: 1997, *Tense and Aspect. From Semantics to Morphosyntax*. Oxford: Oxford University Press.
- Giorgi, F. and A. Pianesi: 2004, 'On the Speaker's and the Subject's Temporal Representation' in J. Guéron and J. Lecarme (eds.) *The Syntax of Time*. Cambridge, MA: MIT Press.
- Greenberg, Y.: 2002, 'Two Types of Quantificational Modalized Genericity, and the Interpretation of Bare Plurals and Indefinite Singular NPs', in *Proceedings of SALT XII*. Ithaca, NY: CLC Publications, Cornell University.
- Grice, H.P.: 1975, 'Logic and Conversation', in P. Cole & J. Morgan (eds.) *Syntax and Semantics 3: Speech Acts*. New York: Academic Press, 41-58.
- Hackl, M.: 1998, 'On the Semantics of "Ability Ascriptions", ms., Massachusetts Institute of Technology.
- Hacquard, V.: 2004, 'Aspect and Implication: Too and Enough Constructions', in *Proceedings of Sinn und Bedeutung 9*, Nijmegen.
- Hacquard, V.: 2005, 'Aspects of Too and Enough Constructions', in *Proceedings of SALT XV*. Ithaca NY: CLC Publications, Cornell University.
- Han, C.H.: 1996, 'Comparing English and Korean Counterfactuals: The Role of Verbal Morphology and Lexical Aspect in Counterfactual Interpretation'. ms.
- Heim, I.: 1982, *The semantics of Definite and Indefinite Noun Phrases*. Ph.D. Thesis, University of Massachusetts, Amherst.
- Heim, I.: 1992, 'Presuppositions Projection and the Semantics of Attitude Verbs'. *Journal of Semantics* 9, 183-221.
- Heim, I.: 2000, 'Degree Operators and Scope' in B. Jackson and T. Matthews (eds.) *Proceedings of SALT 10*, CLC Publications, Cornell University.
- Heim, I.: 2002, 'Features of Pronouns in semantics and morphology, handout of a talk given at USC on January 31st, 2002.
- Heim, I. and A. Kratzer: 1998, *Semantics in Generative Grammar*. Oxford: Blackwell.
- Higginbotham, J.: 1985, 'On Semantics'. *Linguistic Inquiry* 16.
- Hintikka, J.: 1962, *Knowledge and Belief*. Cornell University Press.

- Hintikka, J.: 1969, 'Semantics for Propositional Attitudes' in J. W. Davis *et al.* (eds.) *Philosophical Logic*. Dordrecht, 21-45.
- Huitink, J.: 2006, 'Can Quantifiers Scope over Epistemic Modals?', ms., University of Nijmegen.
- Iatridou, S.: 1988/1993, 'On Nominative Case Assignment and a Few Related Things', in MITWPL 19. Cambridge, MA: MITWPL.
- Iatridou, S.: 1990, 'The Past, the Possible and the Evident', *Linguistic Inquiry* **21.1**, 123-129.
- Iatridou, S.: 2000, 'The Grammatical Ingredients of Counterfactuality'. *Linguistic Inquiry* **31.2**, 231-270.
- Iatridou, S., E. Anagnostopoulou, and R. Izvorski: 2001, 'Observations about the Form and Meaning of the Perfect, in M. Kenstowicz (ed.) *Ken Hale: A life in Language*. Cambridge, MA: MIT Press.
- Ippolito, M.: 2003, 'Presuppositions and Implicatures in Counterfactuals'. *Natural Language Semantics* **11**, 145-186.
- Ippolito, M.: 2004, 'Imperfect Modality', in J. Guéron and J. Lecarme (eds.) *The Syntax of Time*. Cambridge, MA: MIT Press.
- Jackendoff, R.: 1972, *Semantic Interpretation in Generative Grammar*. Cambridge, MA: The MIT Press.
- Karttunen, L.: 1971, 'Implicative Verbs'. *Language* **47**, 340-358.
- Karttunen, L.: 1973, *The Last Word*, mimeograph, University of Texas, Austin.
- Karttunen, L.: 1974, 'Presupposition and Linguistic Context'. *Theoretical Linguistics* **1**, 181-194.
- Karttunen, L. and S. Peters: 1979, 'Conventional Implicatures', in Ch. K. Oh and P.A. Dinneen (eds.) *Syntax and Semantics 11: Presupposition*, New York: Academic Press.
- Kayne, R.: 1991, 'Romance Clitics, Verb Movement, and PRO'. *Linguistics Inquiry* **22-4**, 647-686.
- Klein, W.: 1994, *Time in Language*. London/New York: Routledge.
- Koopman, H. and A. Szabolcsi: 2001, *Verbal Complexes*. Cambridge, MA: The MIT Press.
- Kratzer, A.: 1977, 'What *must* and *can* must and *can* mean'. *Linguistics and Philosophy* **1**, 337-355.

- Kratzer, A.: 1981, 'The notional category of modality' in H.-J. Eikmeyer and H. Rieser (eds.), *Words, Worlds, and Contexts. New Approaches in Word Semantics*. Berlin: de Gruyter, 38-74.
- Kratzer, A.: 1991, 'Modality', in A. von Stechow and D. Wunderlich (eds.) *Semantik: Ein internationales Handbuch zeitgenoessischer Forschung*. Berlin: De Gruyter, 639-650.
- Kratzer, A.: 1996, 'Severing the external argument from the verb', in J. Rooryck and L. Zarin (eds.) *Phrase Structure and the Lexicon*. Dordrecht: Kluwer.
- Kratzer, A.: 1998, 'More Structural Analogies Between Pronouns and Tenses', in D. Strolovich and A. Lawson (eds.) *Proceedings of SALT VIII*. Ithaca, NY: CLC Publications, Cornell University.
- Krifka M., F. J. Pelletier, G. N. Carlson, A. ter Meulen, G. Link and G. Chierchia: 1995, 'Introduction', in G. N. Carlson & F. J. Pelletier (eds.) *The Generic Book*, Chicago: The University of Chicago Press.
- Kripke, S.: 1972, 'Naming and Necessity', in D. Davidson and H. Gilbert (eds.) *Semantics of Natural Language*, Dordrecht: Reidel.
- Kusumoto, K.: 2002, 'On the Quantification over Times in Natural Language'. *Natural Language Semantics* 13, 317-357.
- Landman, F.: 1992, 'The Progressive', *Natural Language Semantics* 1.
- Lawler, J.: 1973, *Studies in English Generics*. University of Michigan Papers in Linguistics 1.
- Lekakou, M.: 2004, 'Middles as Disposition Ascriptions', in *Proceedings of Sinn und Bedeutung* 8.
- Lenci, A. and P. Bertinetto: 2000, 'Aspect, Adverbs and Events: Habituality vs. Perfectivity', in J. Higginbotham, F. Pianesi and A. Varzi (eds.) *Speaking of Events*. Oxford/New York: Oxford University Press.
- Levinson, S.: 1983, *Pragmatics*. Cambridge: Cambridge University Press.
- Levinson, D.: 2003, 'Probabilistic Model-Theoretic semantics for 'want'', in *Proceedings of SALT XIII*. Ithaca, NY: CLC Publications, Cornell University.
- Lewis, D.: 1968, *On the Plurality of Worlds*. Oxford: Basil Blackwell.
- Lewis, D.: 1973, *Counterfactuals*. Cambridge, MA: Harvard University Press.

- Lewis, D.: 1975, 'Adverbs of Quantification', in E. Keenan (ed), *Formal Semantics of Natural Language*. Cambridge, MA: Cambridge University Press, 3-15.
- Lewis, D.: 1983, *Philosophical Papers*. New York/Oxford: Oxford University Press.
- Marantz, A.: 1984, *On the Nature of Grammatical Relations*, MIT Press, Cambridge, MA.
- Marantz, A.: 1984, *On the Nature of Grammatical Relations*, MIT Press, Cambridge, MA.
- MacFarlane, J.: 2003, 'Epistemic Modalities and Relative Truth', ms., UC Berkeley.
- Meier, C.: 2003, 'The Meaning of *too*, *enough* and *so... that*'. *Natural Language Semantics* 11.
- Mondadori, F.: 1978, 'Remarks on Tense and Mood: The Perfect Future', in F. Guenther and C. Rohrer (eds.), *Studies in Formal Semantics: Intensionality, Temporality, Negation*. Amsterdam: North Holland.
- Morzycki, M.: 2005, *Mediated Modification: Functional Structure and the Interpretation of Modifier Position*. Ph.D. Thesis, University of Massachusetts, Amherst.
- Moulton, K.: 2006, 'Thoughts towards an Event Analysis of Obligatory Control', ms., University of Massachusetts, Amherst.
- Musan, R.: 1995, *On the Temporal Interpretation of Noun Phrases*. Ph.D. Thesis, Massachusetts Institute of Technology.
- Musan, R.: 1997, 'Tense, Predicates, and Lifetime Effects'. *Natural Language Semantics* 5: 271-301.
- Napoli, D.: 1981, 'Semantic Interpretation vs. Lexical Governance: Clitic climbing in Italian'. *Language* 57: 841-87.
- Nilsen, Ø.: 2003, *Eliminating Positions*. Ph.D. Thesis, Utrecht University.
- Ninan, D.: 2005, 'Two Puzzles about Deontic Necessity', in J. Gajewski, V. Hacquard, B. Nickel and S. Yalcin (eds.) *New Work on Modality, MITWPL 51*. Cambridge, MA: MITWPL.
- Nissenbaum, J.: 2000, *Investigations of Covert Phrase Movement*, Ph.D. Thesis, Massachusetts Institute of Technology.
- Nissenbaum, J.: 2005, 'Kissing Pedro Martinez: (Existential) Anankastic Conditionals and Rationale Clauses', in *Proceedings of SALT XV*. Ithaca, NY: CLS Publications, Cornell University.
- Ogihara, T.: 2000, 'Counterfactuals, Temporal Adverbs, and Association with Focus', in *Proceedings of SALT X*. Ithaca, NY: CLS Publications, Cornell University.

- Palmer, F. R.: 1986, *Mood and Modality*. Cambridge: Cambridge University Press.
- Partee, B.: 1973, 'Some Structural Analogies Between Tenses and Pronouns'. *The Journal of Philosophy*, 601-609.
- Percus, O.: 2000, 'Constraints on some other variables in syntax'. *Natural Language Semantics* **8**, 173-229.
- Pianesi, F. and A. Varzi: 2000, 'Events and Event Talk: An Introduction', in J. Higginbotham, F. Pianesi and A. Varzi (eds.) *Speaking of Events*. Oxford/New York: Oxford University Press.
- Piñón, C.: 2003, 'Being able to' in G. Garding and M. Tsujimura (eds.) *WCCFL 22 Proceedings*. Somerville, MA: Cascadilla Press, 384-397.
- Portner, P.: 1994, 'The Semantics of Mood, Complementation and Conversational Force', ms., Georgetown University, Washington.
- Portner, P.: 1998, 'The Progressive in Modal Semantics'. *Language* **74**: 760-787.
- Portner, P.: 2005, 'The Semantics of Imperatives within a Theory of Clause Types', in K. Watanabe and R. B. Young (eds.) *Proceedings of SALT XIV*. Ithaca, NY: CLC Publications.
- Rizzi, L.: 1982, 'A Restructuring Rule', in L. Rizzi (ed.) *Issues in Italian Syntax*. Dordrecht: Foris, 1-76.
- Rizzi, L.: 1997, 'The Fine Structure of the Left Periphery', in L. Haegeman (ed.) *Elements of Grammar*. Dordrecht: Kluwer.
- Rochette, A.: 1988, *Semantic and Syntactic Aspects of Romance sentential complementation*. Ph.D. Thesis, Massachusetts Institute of Technology.
- Rosen, S. T.: 1989, *Argument Structure and Complex Predicates*, Ph.D. Thesis, Brandeis University.
- Rosen, S. T.: 1990, 'Restructuring Verbs are Light Verbs', in *Proceedings of WCCFL 9*.
- Ross, J. R.: 1970, 'On Declarative Sentences', in R. A. Jacobs and P. S. Rosenbaum (eds.) *Readings in English Transformational Grammar*. Waltham, Mass.: Ginn.
- Sadock, J.: 1974, *Towards a Linguistic Theory of Speech Acts*. New York: Academic Press.
- Sauerland, U.: 2002, 'The Present Tense is Vacuous'. *Snippets* **6**.
- Sharvit, Y.: 2003, 'Trying to be Progressive: the Extensionality of Try'. *Journal of Semantics* **20**, 403-445.

- Schlenker, P.: 1999, *Propositional Attitudes and Indexicality, A Cross-Categorical Approach*. Ph.D. Thesis, Massachusetts Institute of Technology.
- Schlenker, P.: 2005, 'The French Subjunctive as a Semantic Default'. *Tense, Mood and Modality Colloquium*, handout, Paris.
- Schlenker, P.: *to appear*, 'The Lazy Frenchman's Approach to the Subjunctive (Speculations on Reference to Worlds and Semantic Defaults in the Analysis of Mood)', in *Proceedings of Going Romance XVII*.
- Schlenker, P.: *to appear*: 'Ontological Symmetry in Language: A Brief Manifesto'. *Mind and Language*.
- Schubert, L. and F. J. Pelletier: 1989, 'Generically Speaking, or, Using Discourse Representation Theory to Interpret Generics', in G. Chierchia, B. Partee, and R. Turner (eds.) *Properties, Types and Meaning II*.
- Smith, C.: 1991, *The Parameter of Aspect*. Kluwer Academic Press.
- Speas, P.: 2004, 'Person (and Mood and Tense) and Indexicality'. Paper presented at the Harvard Workshop on Indexicals, Speech Acts, and Logophors, November 20, 2004.
- Stalnaker, R.: 1968, 'A Theory of Conditionals'. *Studies in Logical Theory. American Philosophical Quarterly*.
- Stalnaker, R.: 1981, 'A Defense of the Conditional Excluded Middle', in R. Stalnaker, W. Harper and G. Pearce (eds.) *Ifs: Conditionals, Belief, Decision, Chance, and Time*. Dordrecht: Reidel.
- Stalnaker, R.: 1984, *Inquiry*. Cambridge, MA: MIT Press.
- von Stechow, A.: 1984, Comparing Semantic Theories of Comparison. *Journal of Semantics* 3.
- von Stechow, A.: 1996, 'The Different Readings of *Wieder* 'Again': A Structural Account. *Journal of Semantics* 13, 87-138.
- von Stechow, A.: 2002, 'Temporal Prepositional Phrases with Quantifiers: Some Additions to Pratt and Francez (2001)'. *Linguistics and Philosophy* 25.
- von Stechow, A.: 2003, 'Feature Deletion under Semantic Binding: Tense, Person and Mood under Verbal Quantifiers', In *Proceedings of NELS 33*.
- von Stechow, A., S. Krasikova and D. Penka: 2004a, 'The Meaning of German *um zu*: Necessary Condition and *enough/too*', in *Workshop on Modal Verbs and Modality* hand-out, Tübingen.

- von Stechow, A., S. Krasikova and D. Penka: 2004b, 'Anankastic Conditionals', ms., University of Tübingen.
- Stephenson, T.: 2005, 'Assessor Sensitivity: Epistemic Modals and Predicates of Personal Taste', in J. Gajewski, V. Hacquard, B. Nickel and S. Yalcin (eds.) *New Work on Modality, MITWPL 51*. Cambridge, MA: MITWPL.
- Stephenson, T.: 2006, 'A Parallel Account of Epistemic Modals and Predicates of Personal Taste', ms., Massachusetts Institute of Technology.
- Stowell, T.: 1995, 'The Phrase Structure of Tense', in J. Rooryck and L. Zaring (eds.) *Phrase Structure and the Lexicon*, Dordrecht: Kluwer.
- Stowell, T.: 2004, 'Tense and Modals', in J. Guéron & J. Lecarme (eds.) *The Syntax of Time*. Cambridge, MA: MIT Press.
- Stone, M.: 1997, 'The Anaphoric Parallel between Modality and Tense'. IRCS Report 97-06, University of Pennsylvania.
- Thomason, R.: 2005, 'Ability, Action, and Context', ms., University of Michigan, available at: <http://www.eecs.umich.edu/~rthomaso/documents/action/ability.pdf>
- Travis, L.: 1994, 'Event Phrase and a Theory of Functional Categories', in *Proceedings of the Canadian Linguistics Association Meeting*, University of Calgary.
- Villalta, E.: 2000, 'Spanish Subjunctive Clauses Require Ordered Alternatives', in *Proceedings of SALT X*. Ithaca, NY: Cornell University.
- Westmoreland, R.: 1998, *Information and Intonation in Natural Language Modality*. Ph.D. Thesis, Indiana University.
- Wurmbrand, S.: 1998, 'Restructuring Control', in *U.Penn Working Papers in Linguistics 5.1*.
- Wurmbrand, S.: 1999, 'Modal verbs must be raising verbs', in S. Bird, A. Carnie, J. Haugen and P. Norquest (eds.) *Proceedings of WCCFL 18*.
- Wurmbrand, S.: 2001, *Infinitives*. New York: Mouton de Gruyter.
- Zagona, K.: 2005, 'Epistemic Modals and Assertion'. *Tense, Mood and Modality Colloquium*, handout, Paris.