

The Impact of Information Technologies on Air Transportation

R. John Hansman*

Massachusetts Institute of Technology, Cambridge MA 02139, USA

The Air Transportation System and several key subsystems including the Aircraft, Airline, and Air Traffic Management are modeled as interacting control loops. The impact of Information Technologies on each of these subsystems is evaluated through the performance of these control loops. Information technologies are seen to have a significant impact on the safety, efficiency, capability, capacity, environmental impact and financial performance of the Air Transportation System and its components.

Introduction

The US and International Air Transportation Systems have demonstrated remarkable growth and increased performance over the past few decades. Fig.1 demonstrates the growth in passenger and cargo traffic in international regions since 1972. Strong growth can be seen in North America and Europe which continue to dominate the passenger traffic. In addition, extraordinary growth can be seen in Asia/Pacific which has dominated the cargo traffic since the early 1990's.

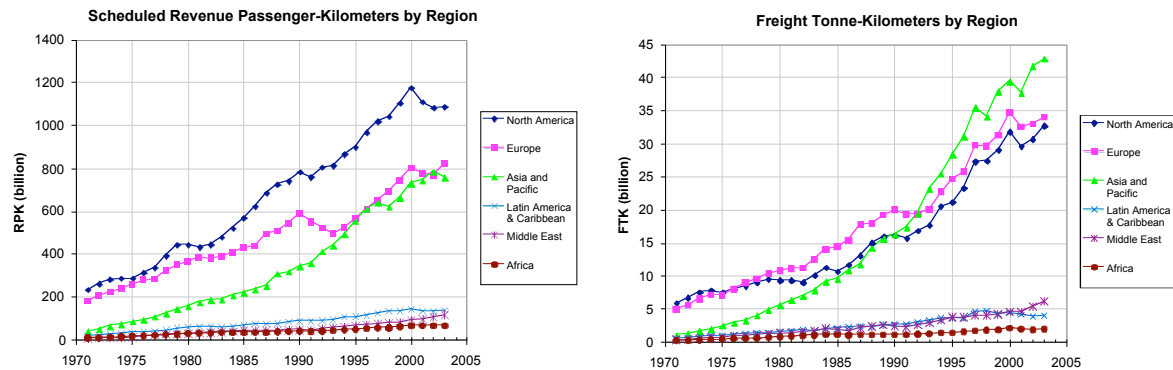

Figure 1. Scheduled Passenger and Cargo Traffic by Region.¹

This growth in traffic has been accompanied by an increase in safety and cost efficiency. The world commercial jet aircraft fatal or hull loss accident rate decreased by a factor of 5 from 1972 to 2002 and by more than 25 from the entry of commercial jet aircraft in the early 1960's.² Cost efficiency has also increased. The average Cost per Available Seat Mile (CASM) for U.S. Airlines has decreased by over 40% since the late 1970's.³ It is interesting to note that this period of strong air transportation performance correlates with both the deregulation of the U.S. Airline Industry in 1978 and the growth in Information Technologies. The commercial introduction of the microprocessor was in 1971 and the introduction of the Intel 8086 processor (which powered most personal computers) occurred in 1978 (Ref. 4) the year the US Airline industry was deregulated.

This paper explores the impact of Information Technologies on Air Transportation and attempts to identify key Information Technology trends, emergent issues and future opportunities for Air Transportation. In order to limit its scope, this paper will focus primarily on Information Technologies that influence operational closed loop feedback control at various levels. It will not address Information Technologies such as CFD and computational modeling which have had a significant impact on vehicle design.

* Professor, MIT Department of Aeronautics and Astronautics, 33-303 MIT, Cambridge MA 02139, AIAA Fellow
Copyright © by MIT. Published by the American Institute of Aeronautics and Astronautics, Inc. with permission.

Air Transportation System Elements

The Air Transportation System is a classic example of what has become known as a “System of Systems”. It is an evolved complex system with many interacting subsystems. These subsystems include technical, operational, organizational and social components. For the purposes of this paper the Air Transportation System will be parsed into several interacting subsystems:

the Vehicle System (Including the Pilot), the Air Traffic Management (ATM) System, the Airline System and the Air Transportation System. The interaction of these subsystems is shown graphically in the Venn diagram in Fig. 2. The Vehicle System is the smallest operational system element in this decomposition. The control of the vehicle and its subsystems constitute the inner loop of the air transportation system. The vehicle is a joint element of Airline and the Air Traffic Management subsystems which interact operationally through joint control of the vehicles they are responsible for. The Airline System also includes a business component that involves scheduling and pricing. All of these subsystems are part of a macro loop that defines the response of the overall Air Transportation System to demand and other social, technical and operational drivers. Each of these systems and control loops will be discussed in more detail below.

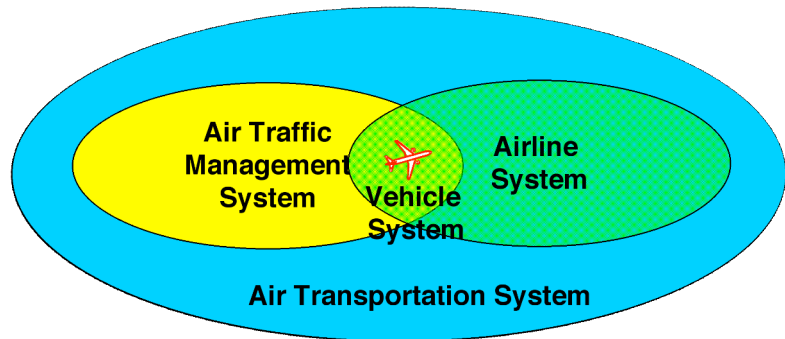

Figure 2. Air Transportation System Elements.

A. Air Transportation System Level

A simple conceptual model of the interaction loop between the Air Transportation Systems and the economy is shown in Fig. 3. The Air Transportation System is represented by the capability of the National Airspace System (NAS), the capability of the vehicles and operators (e.g. Airlines). Internal to the Air Transportation System is a supply and demand loop where the airlines provide supply through their schedule and pricing. At the macroeconomic level the Air Transportation System interacts with the economy through several mechanisms. The economy provides both the source of demand and capital which drives the Air Transportation System. In turn, the Air Transportation System drives the economy through traditional macroeconomic mechanisms such as direct, indirect and induced employment effects. However, air transportation also provides an economic “enabling” effect in the form of rapid access to people, markets, ideas and capital. While this “enabling” effect is difficult to measure directly, it is hypothesized that the availability of low cost air travel, coupled with low cost telecommunication has reduced geographical barriers and stimulated economic and social mobility within the U.S. and internationally. This can be observed in the growth of national and international business activity and perhaps more strikingly in social diffusion as families and other social units expand geographically following economic and quality of life opportunities.

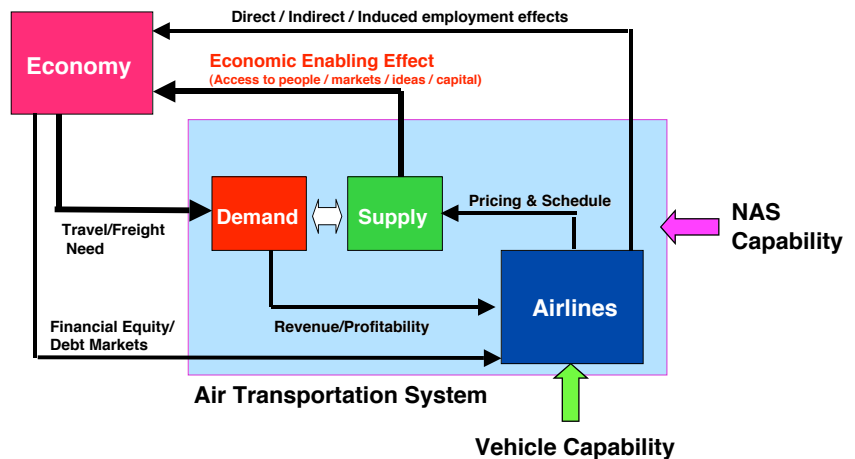

Figure 3. Air Transportation System Macroeconomic Interaction Model.

The interaction between air transportation and the economy can be seen in Fig. 4 which shows the annual growth in U.S. GDP and U.S. Passenger Traffic measured in Revenue Passenger Miles (RPM). The clear correlation between GDP and air transportation activity that is observed in the U.S. is also seen in other parts of the world. It is

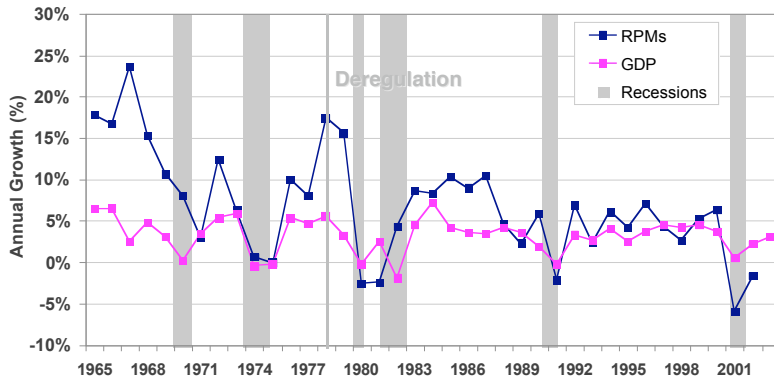

Figure 4. Correlation between U.S. Passenger Traffic and GDP.
Data source: US Bureau of Economic Analysis and Bureau of Transportation Statistics.

not clear if a strong economy simply provides sufficient discretionary income to stimulate air travel or if strong air travel stimulates economic development however it is likely that both contribute.

The U.S. National Airspace System (NAS) includes the Airports, Air Navigation, Surveillance, Communication, ATC and Weather systems. The accessibility of the NAS is illustrated in Fig. 5 which depicts the distribution of the 3175 public airports.⁵ The airport distribution generally correlates with the U.S. population distribution. A majority of traffic flows through the top 60 airports and much of the air

traffic is concentrated in the Eastern U.S. and at hub airports which can be seen in the plot of U.S. air traffic density shown in Fig. 6. This concentration is a natural consequence of the hub and spoke network structure which has evolved in the U.S. This structure is very efficient at providing accessibility throughout the network but also results in peak demand traffic concentrations and non-linear propagation of disturbances in the network.

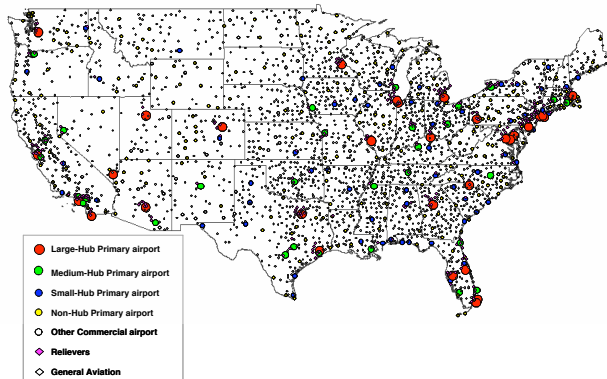

Figure 5. US National Airport System.
Data Source: FAA.⁵

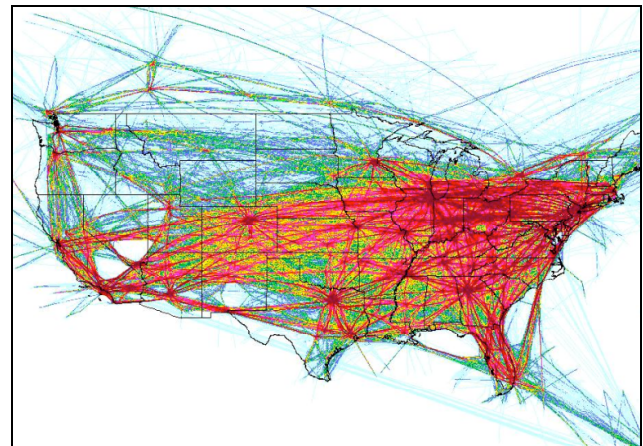

Figure 6. US Air Traffic Density.

There are indications that the U.S. National Airspace System (NAS) is approaching capacity limits at key points in the system. Nominal interruptions due to weather or other factors result in non-linear amplification of delays. This can be seen in the FAA reported monthly delays in Fig. 7. Starting in 2000, the system began to saturate due to traffic growth, weather interruptions, and over scheduling at New York’s LaGuardia (LGA) airport. Decreased traffic following the September 11 attacks in 2001 reduced pressure on the system until late 2003 when a return of traffic and over scheduling of Chicago’s O’Hare airport (ORD) increased delays to record levels.

The factors that determine the capacity limits of the National Airspace System include Airport and Airspace Capacity. At the airport level, the key constraint is runway capacity limited by wake vortex separation requirements.

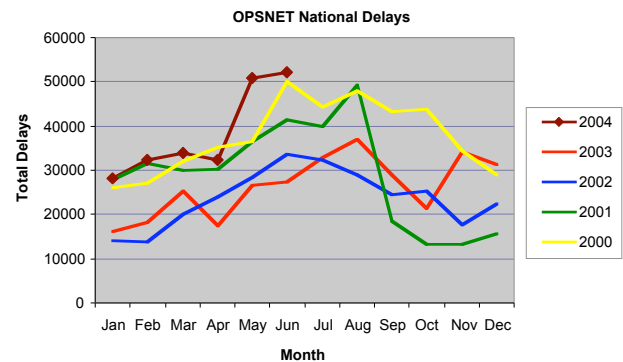

Figure 7. US Flight Delays Reported by FAA.⁶

However it is important to note that the airport, like the NAS, is a complex adaptive system. The capacity of the other elements of the airport system, such as gates, taxiways, and landside systems such as parking are matched to the runway capacity. Increasing runway and airport capacity at the most constrained points of the NAS is difficult due to environmental limitations regarding noise and emissions. Information technology enabled operations such as low noise approaches and efficient airport surface management may mitigate these limitations.

Airspace capacity is limited by controller workload, airspace design, separation standards and the buffering capacity of the system. Aircraft flows are restricted to assure that downstream sectors do not exceed acceptable levels of traffic, which are set by controller workload and procedural limitations. Because of the limited ability of the system to buffer aircraft in the air and difficulties in coordination across multiple sectors, the system normally runs well below the theoretical maximum capacity.

Capacity issues and delays are expected to grow in the future as air transportation activity continues to increase. Only marginal increases in airport and airspace capacity are expected under existing operating procedures. New operating paradigms have been proposed based on information technologies such as airborne self separation to increase airspace capacity and dependant parallel or formation approach and departure procedures to increase airport capacity. However, major changes in operating procedures are difficult to implement and will likely require a major capacity crisis or other transformative event to stimulate system change.

B. Vehicle System Level

At the Vehicle System level there have been profound changes in aircraft systems driven by Information Technologies over the past few decades. This is strikingly apparent in the transformation from “Steam Gauge” cockpits with electromechanical analogue instrumentation to digital “Glass Cockpit” displays. Some aircraft such as the Boeing B-737 and B-747 series have models that span this cockpit transformation illustrating the rapid change in information technologies within the vehicle system. While the cockpit changes may be the most apparent, they are only part of deeper IT changes in the vehicle subsystems.

There have been significant IT impacts at the Vehicle System level. These include safety improvements, resulting from enhanced flight control, the incorporation of alerting systems and improved crew situation awareness displays. Other impacts include capability improvements such as all weather operations and operational efficiency improvements such as increased fuel efficiency and reduction in required crew.

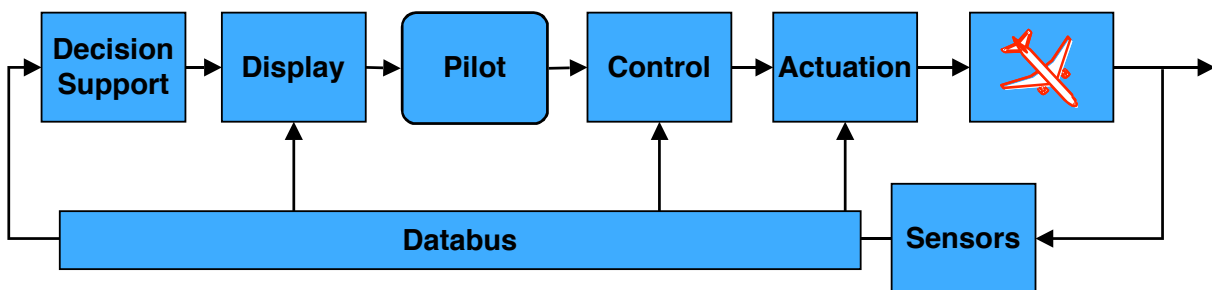

Figure 8. Basic Vehicle Information Flow.

As an example, some of the key IT trends and impacts on each of the major elements in the aircraft information flow loop represented generically in Fig. 8 are discussed below.

Databus – The digital databus has transformed aircraft information architectures. The databus architecture allows data to be used by multiple elements in the information architecture and enables a degree of functional interaction and coordination between components that was not feasible in analogue or pneumatic information transmission systems. The databus architecture includes both the physical elements and the interface standards.

Sensors – Individual sensor technology has been revolutionized by electronic and microprocessor enabled sensor systems. These sensors have enhanced performance and other desirable characteristics such as linear output, automatic compensation and databus compatible outputs. Entirely new classes of sensors are evolving such as micromechanical sensors and multi-sensor systems. An example is the modern air data system that electronically compensates for static system installation errors as well as thermal and other effects. The improved air data system performance has had the effect of allowing Reduced Vertical Separation Minima (RVSM) at high altitudes, doubling the number of flight levels above 29,000 ft and increasing airspace capacity.

Navigation sensors have also evolved and have had a significant impact on vehicle capability. Radio beacon systems such as VOR/DME have been supplemented by Inertial Reference Systems (IRS) and more recently by satellite based systems such as GPS. New complementary satellite systems such as Galileo are in development. For approach navigation, ILS precision approach capability has evolved to allow zero visibility landings (Cat III) for appropriately equipped airports and aircraft. GPS is currently used for non-precision approaches and several augmentation systems have been developed to allow GPS precision approach capability.

Radio communication capability has also evolved. Increased bandwidth in voice and data channels is available through new modulation approaches and software based radios. Satellite based communication networks are emerging from their initial applications in oceanic operations to domestic operations. Air-Ground datalink capability implementation has been somewhat limited by the inability to reach consensus on standards.

A number of External Threat Sensors have been developed which have had a significant impact on flight safety. Airborne weather radar has reduced the convective weather encounters. Radar altimeter based Ground Proximity Warning Systems (GPWS) terrain data base enhancements and Terrain Awareness Warning Systems (TAWS) have reduced the incidence of Controlled Flight Into Terrain (CFIT). Traffic Collision and Avoidance Systems (TCAS) have provided a redundant safety net when Air Traffic Control facilities fail.

Actuation – Actuation capability has evolved from mechanically driven hydraulic actuators to Fly By Wire (FBW) and Fly By Light (FBL) systems. Fly by Wire systems were initially developed for military aircraft to allow enhanced maneuvering performance. Their incorporation on commercial aircraft is primarily driven by cost and manufacturing considerations but does open up opportunities in flight control design. There are, however, significant cost and complexity issues due to the hardware and software integrity requirements in critical flight FBW/FBL control systems.

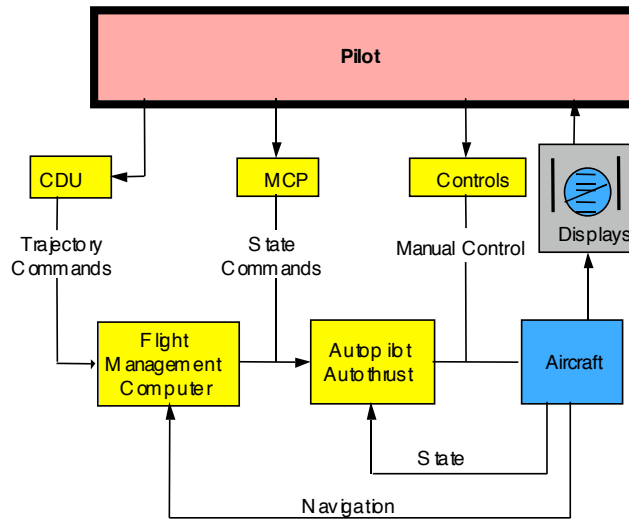

Figure 9. Autoflight Control Loops.

Vertical/Speed Domain				
Stab Augmentation	Attitude Control	State Control	Trajectory Control	Envelope Protection
FBW System	Turn/Pitch Knob Control Wheel Steering Go Around	Altitude Hold Glide Slope Arm Turbulence* EPR Takeoff Vertical Speed Speed Flare Altitude Capture Go Around Idle Thrust Hold Flight Path Angle	Glide Slope Track VNAV Path VNAV Speed VNAV Altitude	Stall protection Overspeed protection
Lateral Domain				
Stab Augmentation	Attitude Control	State Control	Trajectory Control	Envelope Protection
Yaw Dampers FBW System	Turn/Pitch Knob Control Wheel Steering ATT: Hold Engage	Heading Select Heading Hold VOR Track Rollout Takeoff Go Around Track Select Track Hold	Localizer LNAV	Auto Bank Limiting

Figure 10. Mode Proliferation in Boeing Aircraft.⁷

implemented and communicated to the crew. There is some discussion of integrating Terrain Awareness and Warning Systems (TAWS) with FBW envelope protection to prevent CFIT and potential use of aircraft as weapons.

Control – Autoflight systems have evolved from basic autopilot functions such as wing levelers and yaw dampers to more sophisticated 3 axis autopilots and coupled approach capability. Autothrottles evolved from simple mechanically servoed throttles to Full Authority Digital Engine Controllers (FADEC) that provide autothrottle functions and also optimize engine performance and fuel efficiency.

Flight Management Systems (FMS) integrate autoflight and navigation systems to allow trajectory level control (Fig. 9) as well as other flight management functions (e.g. monitoring fuel, estimating weight, performance calculations and automatically tuning the navigation radios). The integrated on Flight Management Systems with Fly By Wire actuation systems has enabled envelope protection (e.g. stall and bank angle limits) as a mechanism to increase flight safety. There are, however, different design philosophies on how these envelope protection limits should be

The evolution of the autoflight systems has resulted in an exponential increase in system complexity, software and the number of autoflight modes as illustrated in Figs. 10 and 11. The increasing role of software in flight critical applications and the growth of software complexity have raised new challenges on the design, certification, operations and life cycle cost containment. The emergence of mode awareness errors in FMS equipped aircraft highlighted the need to include human cognitive considerations in the specification of automation systems and their software.⁷

Displays – As discussed above there has been a significant evolution in cockpit display technologies. Displays have transitioned from electro-mechanically based instrumentation to integrated electronic displays. These displays include Primary Flight Displays (PFD) (Fig. 12) which integrate basic aircraft state and guidance information, Horizontal Situation Displays (HSD) and recently Vertical Situation Displays (VSD) (Figs. 13 and 14) which integrate navigation, FMS and external threat information to enhance pilot situation awareness. Integrated system monitoring displays such as the Airbus Electronic Centralized Aircraft Monitor (ECAM) or Boeing Engine Indicating and Crew Alerting System (EICAS) (Fig. 15) have become standard on modern aircraft cockpits. Head Up Displays (HUD) such as the example in Fig. 16 have emerged in commercial aircraft cockpits primarily for approach and landing guidance and have allowed lower (Cat II) ILS minimums under manual control reducing autopilot calibration and maintenance costs normally required for Cat II approaches.

Information Technology advances such as enhanced databases and communication systems are also changing

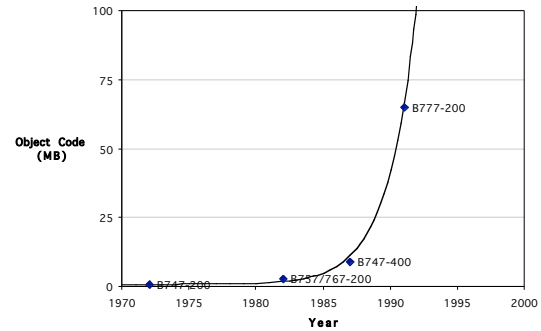

Figure 11. Software Growth in Boeing Aircraft.⁷

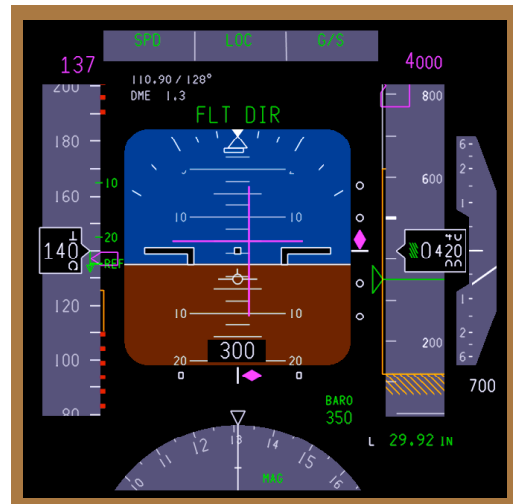

Figure 12. Primary Flight Display.⁸



Figure 13. Boeing Horizontal and Vertical Situation Display.⁸

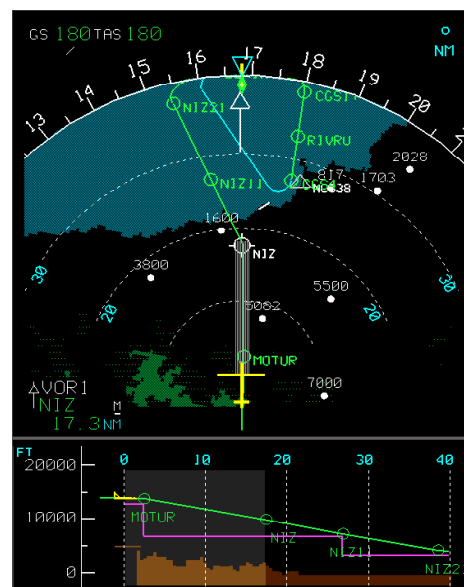

Figure 14. Airbus Horizontal and Vertical Situation Display (courtesy of Airbus).

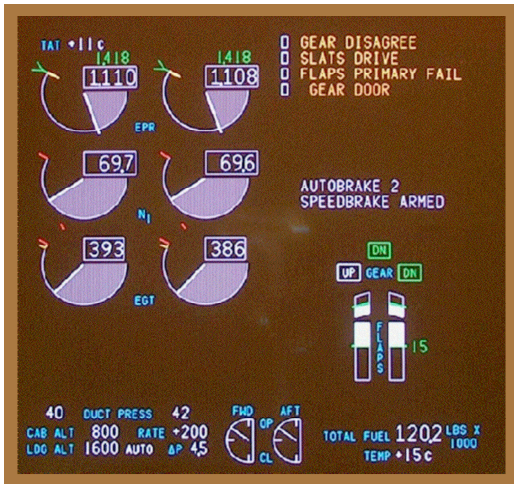

Figure 15. Engine Indicating and Crew Alerting Display.⁸



Figure 16. Head Up Display.⁸

flight documentation from traditional paper based approaches to Electronic documentation systems. Normal and Emergency electronic checklist systems have been incorporated in new aircraft systems (e.g. B777 and A380). Electronic Flight Bag (EFB) systems are emerging which include instrument approach procedure charts as well as Minimum Equipment List (MEL), load planning and other information.

Decision Support - Information Technologies have enabled the emergence of decision support systems including Alerting Systems, Guidance Systems and Planning Systems. Alerting Systems have evolved from basic vehicle state monitoring (e.g. fuel, temperatures, stall warning) to alerting based on external states. This is accomplished based on the advanced sensor technologies discussed above (Weather Radar, EGPWS, TCAS). Guidance Systems have evolved from Course Deviation Indicators (CDI) to Flight Directors (FD) integrated with the aircraft radio navigation or FMS systems. Planning Systems are integrated into the FMS to support flight planning, fuel management, and weight and balance analysis.

Crew - Required flight crew for commercial flight operations have been systematically reduced by the incorporation of Information Technologies as well as the design of simpler systems and procedures. As flight crew are a major operational cost, this has resulted in increased cost efficiency and operational flexibility. In the 1950's a trans oceanic cockpit crew would consist of 5 (Captain, First Officer, Flight Engineer, Navigator, Radio Operator). Advances in radio systems such as frequency tuning and selective addressing (SELCAL) allowed the radio operator to be eliminated. The incorporation of advanced long-range navigation systems (initially IRS systems and subsequently GPS) replaced the Navigator. System simplification and system alerting systems (e.g. EICAS, ECAM) allowed the Flight Engineer to be eliminated resulting in the current crew complement of 2 pilots (Captain and First Officer).

The increasing capability of Autoflight systems coupled with the recent successes of military UAVs has raised the potential of uncrewed air transport for cargo and ultimately passenger carrying operations in the mid or far future. The barriers to uncrewed operations are more social and regulatory than technical. However they raise questions regarding the allocation of function and responsibility between humans and automation.

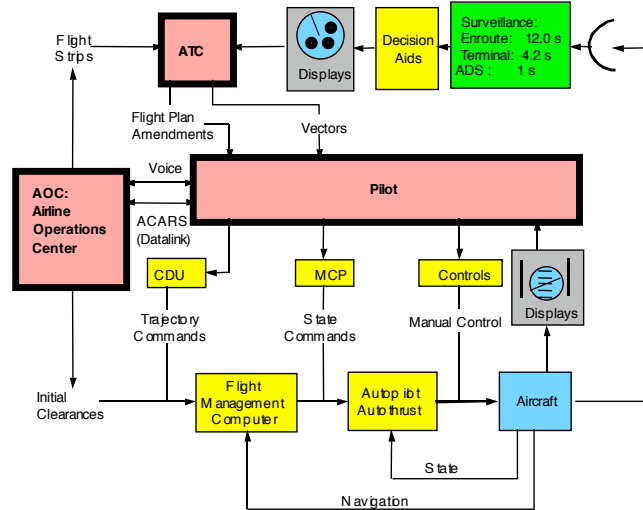

Figure 17. Air Traffic Management Tactical Control Loop.

C. Air Traffic Management System Level

The key Information Technologies in Air Traffic Management are; Communication, Navigation, Surveillance, Decision Support and Information Sharing Systems. At the tactical level the basic control loop is shown in Fig. 17. The Air Traffic Controller receives aircraft state information through surveillance systems and issues commands (i.e. clearances) over voice communication channels. These commands are executed by the pilot using the aircraft autoflight and navigation systems.

The navigation systems historically determine the airway structure of the ATM system as airways were required to pass over traditional radio beacons. As area based navigation systems become dominant, the airway structure will become more flexible and efficient. However, this has yet to be fully realized because the system is required to accommodate legacy navigation systems. Communications are still primarily by voice communications however some datalink ATC communications are slowly emerging generally through airline managed data communication networks such as ACARS.

Aircraft position surveillance is generally through primary or secondary radars. The low update rate of ATC RADARS (typically 12 sec for enroute, 4.2 sec for terminal areas) coupled with radar resolution limits results in conservative radar separation standards and a very slow control loop. Radar resolution has improved significantly over the past 40 years however capacity gains have been limited as separation standards were not changed at the time of improvement and post hoc separation reductions would be perceived as compromising safety. It should be noted that the safety record for aircraft under positive radar control is extraordinary.

Capacity improvements are expected with higher update rate surveillance systems such as Automatic Dependant Surveillance Broadcast (ADS-B) which is in initial implementation. These also offer the potential of direct aircraft to aircraft surveillance which would allow aircraft to self separate in some conditions allowing a much faster and more efficient control process.

Another example of enhanced surveillance are enhanced weather surveillance systems such as the Terminal Doppler Weather Radar (TDWR) which have reduced the exposure to hazardous convective microburst encounters and have been integrated into Integrated Terminal Weather Systems (ITWS) which have increased the safety and capacity of the key airports but providing enhanced and predictive weather information to the controllers.

Information technologies are also being used to improve efficiency and capacity of the ATM system at a more strategic level as seen in Fig. 18 which is adapted from a representation of the ATM system by Haraldsdottier.⁹ The

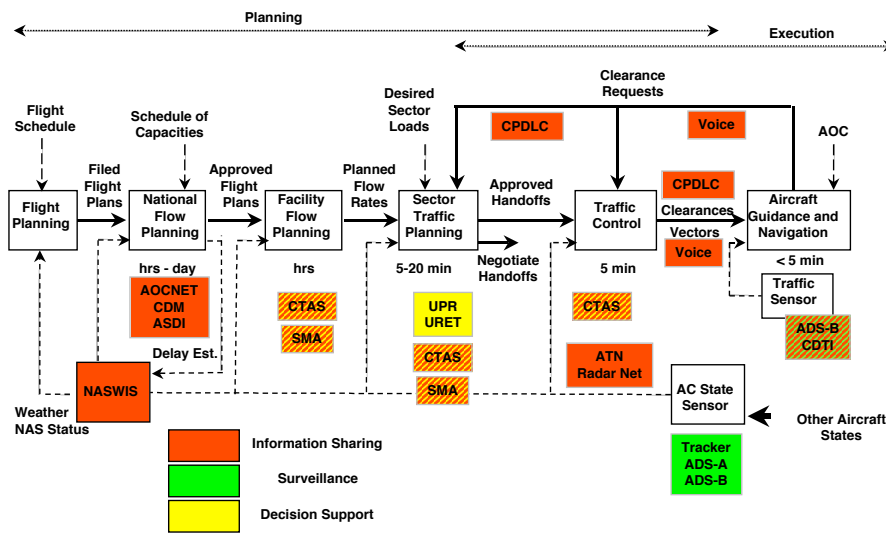

Figure 18. Information Technology Planned Upgrades in the Air Traffic Management Strategic Control Loop (adapted from Ref. 9).

The National ATM system is a series of interacting tactical ATC facilities which must be coordinated to deal with capacity constraints. Currently planned system information system improvements are numerous and beyond the scope of this paper to describe in detail. However, they can be categorized as functionally as improving *Information Sharing*, *Surveillance* or *Decision Support*. It is interesting to note that under current operating conditions the most effective systems appear to be those which support *Information Sharing* to allow enhanced coordination and utilization

of capacity constrained resources in the NAS. Examples include Collaborative Decision Making (CDM) which allow airlines and the FAA to coordinate schedules during weather and traffic based interruptions as well as the Traffic Flow Management function in CTAS which allows schedule coordination between Enroute and Terminal Area ATC Facilities.

D. Airline System Level

A simple model of the key operational control elements at the airline system level is shown in Fig. 15. On the right is the airline operational loop where the Airline Operations Control (AOC) center dispatches and coordinates flights and related resources such as crew, aircraft, maintenance and local station facilities such as gates, ramps, baggage handling, etc. The aircraft are dispatched and controlled in flight in collaboration with Air Traffic Control and the flight crew in a triad of responsibility and control. Passengers and cargo are managed through a passenger processing function that is related to, but separate from, the dispatch control loop. The operational loop is responsible for providing the air transportation services. It's efficiency influences operating costs and the Cost per Available Seat Mile (CASM).

On the left side of Fig. 19 is the business control loop. This loop is responsible for determining flight schedules through the Network Planning process, determining pricing through Revenue Management process and distributing the seat inventory through Marketing and the Computer Reservation Systems. Reservation pattern data is fed back to the revenue management and network planning processes. The efficiency of the business loop controls revenue and determine the Revenue per Available Seat Mile (RASM). The business and operational control loops interact through the flight schedule and individual flight reservations.

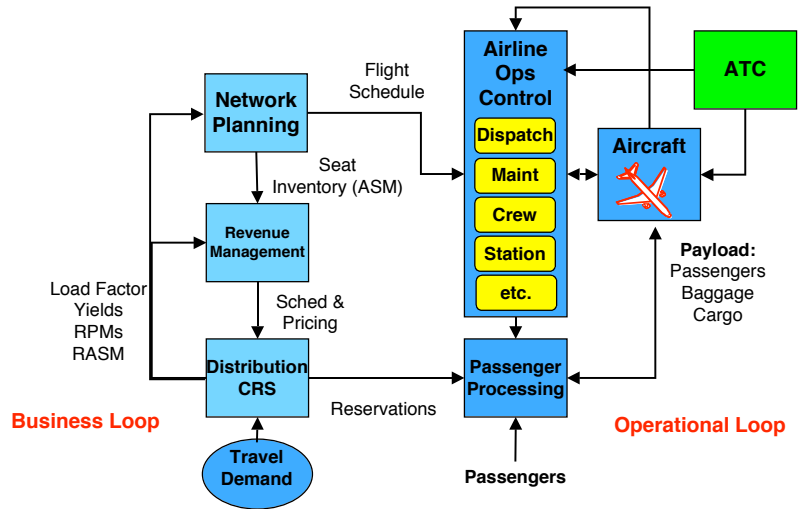

Figure 19. Airline Level Flight Operation and Business Control Loops.

Airline Flight Operations

Communication and surveillance have had a significant impact improving system coordination in the airline operational loop which can often span multiple continents.

For flight operations the Aircraft Communication Addressing and Reporting System (ACARS) VHF datalink is one of the most significant examples. The ACARS system is a commercial air-ground datalink operated by AIRINC limited to text messaging due to it's relatively low bandwidth. ACARS was introduced in the late 1970's and the first application was automatic reporting of aircraft Out, In, Off, On times. Many additional applications followed as illustrated in Fig. 20 and ACARS is now a critical component in many airline operational programs from, dispatch functions, to coordinating passenger transfers, to sending maintenance requests to automatic engine monitoring. These

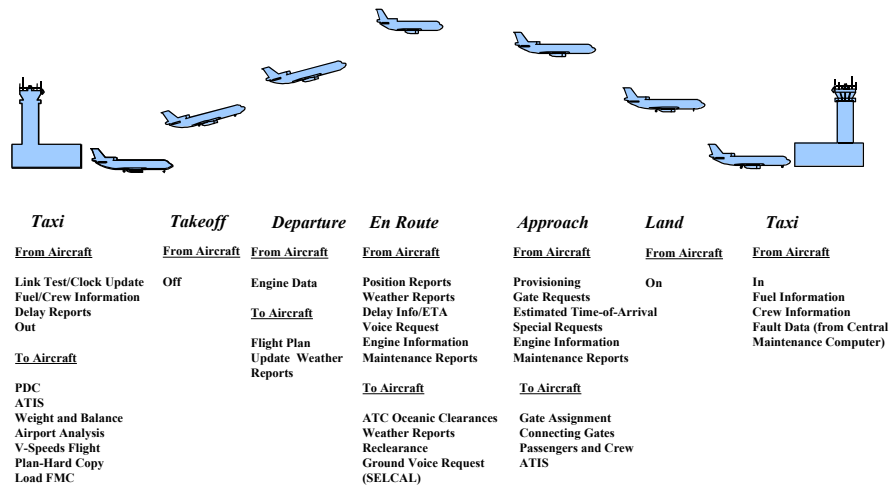

Figure 20. Example ACARS Applications (courtesy of AIRINC).

have had a major impact on cost and operational efficiency. For example, in-flight engine performance monitoring through ACARS is a critical part of engine on-condition maintenance programs which save millions of dollars in extended engine life. ACARS based maintenance reporting improves dispatch reliability by alerting station maintenance of discrepancies so replacement parts can be pre-positioned to allow maintenance within normal scheduled ground times.

Enhanced communication and surveillance systems have also had an impact on the other operational elements of the system. As in many operational industries, cell phones have provided a flexible mechanism to coordinate with crew and personnel distributed over large geographical regions. In-flight communication and passenger entertainment systems have also influence the passenger connectivity. New services such as in-flight internet and cell phone access are in development or testing.

At the station level security requirements such as positive bag match have increased the need for surveillance and tracking of passengers and baggage. Bar code scanning of boarding passes and baggage tags are currently used and RFID approaches have been proposed at several locations. Wireless applications for station level coordination are also being tested.

Scheduling and planning tools have improved the efficiency within many of the airline operational control subfunctions such as maintenance scheduling, crew scheduling and dispatch. However, many of these systems were initially developed and implemented as stand alone systems and airlines are struggling to integrate and upgrade legacy operational systems. There are efforts to integrate the various operational databases into a real time flight operational database to support day of operations activities as illustrated in Fig. 21.

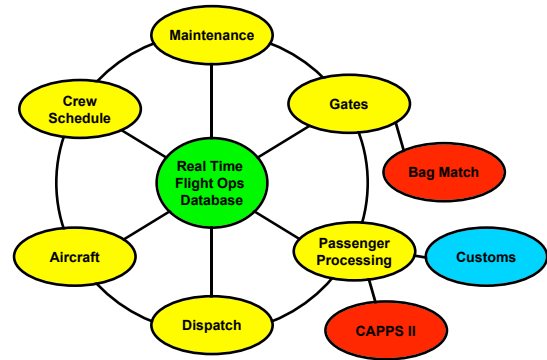

Figure 21. Information Sharing Between Operational Databases.

Airline Business

Optimization and simulation tools have been heavily used to maximize revenue in both the Network Planning and revenue management processes. However clearly the most significant recent IT factor on the airline business loop has been the internet which has shifted the playing field and undermined many of the schedule and pricing assumptions of the traditional airline industry. Airline tickets are the ideal Internet product where a consumer purchases the product online and goes to the point of delivery to receive the product. In 1999, Airline tickets overtook personal computers as the highest category of internet sales in the U.S.¹⁰ The internet has also improved cost efficiency in passenger services through the proliferation of electronic tickets and online or kiosk check-in systems.

The ramification of large volume internet sales has been to increase price competition and decrease the value consumers and airlines place on tightly scheduled airline networks. Traditional Computer Reservation System (CRS) listed flights by elapsed time and there was a premium to be on the first page of the CRS as many ticket agents would not move to the second page. This led to the emergence of hub and spoke systems with very tight connecting banks. As most internet systems display flights by price airlines have begun to modify their scheduling and pricing behavior. In 2003, American Airlines depeaked their bank structure in their DFW and ORD hubs. An example of the DFW original and depeaked departure schedule is show in Fig 22.

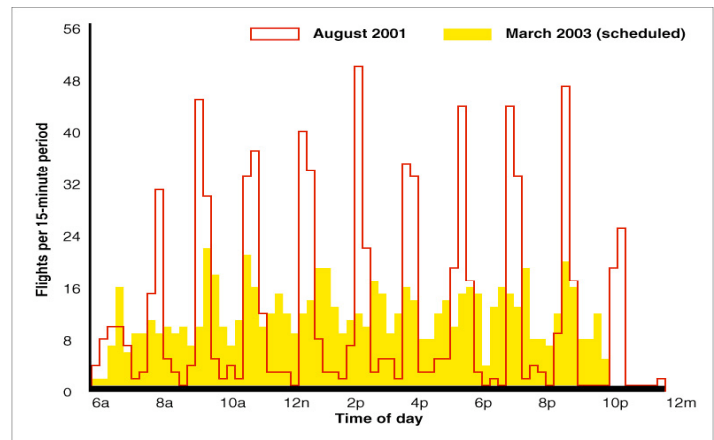

Figure 22. American Airlines Depeaked Schedule at DFW.¹¹

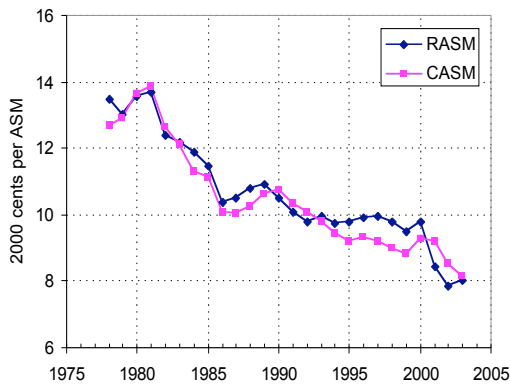

Figure 23. Revenue and Cost per Seat Mile Trends for US Major and Regional Airlines. Source: Air Transportation Association.³

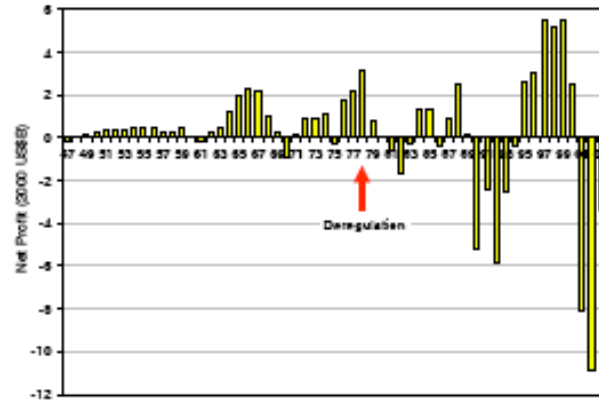

Figure 24. US Airline Net Profits. Source: Air Transportation Association.³

E. Profitability Cycles

The combined impact of industry de-regulation with the efficiencies and competitive pressures resulting from Information Technologies has resulted in greater than a 40% reduction in the average cost per seat mile for US Airlines from 1978 to 2003 as can be seen in Fig. 23 which plots the US industry average RASM and CASM over time. While the major cost reductions have been a boon for the air transportation consumer, the impact on the airline industry has been less positive.

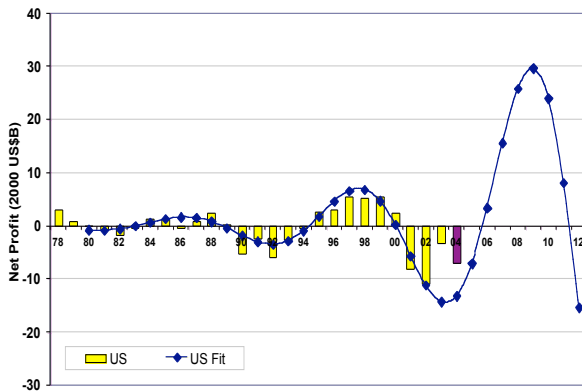

Figure 25. Revenue and Cost per Seat Mile Trends for US Major and Regional Airlines. Source: Air Transportation Association.³

Fig. 24 plots the US Airline net profit in constant 2002 dollars starting in 1947. The system is clearly cyclic with a cycle period of approximately 11.3 years. Prior to deregulation, in 1978, the cycle was stable and the industry was profitable at approximately \$900 million per year averaged over the 11 year cycle. After deregulation the cycle period remained at 11.3 years but the amplitude of the oscillations appears to have grown exponentially in the manner of an undamped second order system as shown in Fig 25. The cause of the profit instability is not fully clear but preliminary simulations indicate that it is partly due to lags in adding capacity during profitable periods, lags in cost adjustment and other exogenous effects such as fuel costs and international conflicts.

Conclusion

Information Technologies have had a substantial role in improving the affordability, safety, capability and efficiency of the air transportation system and influencing the consumer demand for air transportation. The air transportation system is facing substantial challenges in terms of system capacity, financial stability and environmental impact but it is also facing significant opportunities in developing new markets and environmentally friendly operating strategies. Information Technologies will have a key role in these emerging opportunities particularly in the developing regions of the world where air transportation is a key to economic transformation and wireless and satellite based Information Technologies have the potential to allow regions with immature air transportation infrastructure to rapidly reach parity with mature systems.

Acknowledgments

I would like to thank the many current and former students who contributed directly or indirectly to this paper including Helen Jiang, Ryan Tam, Philippe Bonnefoy, Sanjay Vakil, and Aleksandra Mozdzanowska. I would also like to thank Brian Kelly and Aslaug Haraldsdottir of Boeing and John Lauber of Airbus and AIRINC for figures used in this paper.

References

1. ICAO 1966-2002 Civil Aviation Statistics of the World, ICAO Statistical Yearbook, International Civil Aviation Organization, Montreal, 2002.
2. Boeing, 2003 Statistical Summary of Commercial Jet Aircraft Accidents.
3. Jiang, H., Hansman, R. J., "An Analysis of Profit Cycles in the Airline Industry", MIT ICAT Report ICAT-2004-7.
4. Intel, www.intel.com/research/silicon/mooreslaw.htm accessed 1/5/05].
5. FAA National Plan for the Integrated Airport System.
6. FAA OPSNET Data analyzed by Jim Evans, MIT Lincoln Laboratory.
7. Vakil, S., Hansman, R. J., "Approaches to Mitigating Complexity-Driven Issues in Commercial Autoflight Systems," *Reliability Engineering and System Safety*, Elsevier Science, **75** (2002), 133-145, January 2002.
8. Kelly, B., "Flight Deck Design and Integration in Commercial Air Transport", Boeing Presentation to MIT Aircraft Systems Engineering Open Courseware, <http://ocw.mit.edu/OcwWeb/Aeronautics-and-Astronautics/16-885JFall2003/CourseHome/index.htm> [accessed 1/5/05].
9. Haraldsdottir, A., Schwab, R., Alcabin, M., "Air Traffic Management Capacity-Driven Operational Concept Through 2015" 2ne USA/Europe Air Traffic Management R&D Seminar, Orlando, December 1998.
10. U.S Statistical Abstract, 2000.
11. Tam, R., Hansman, R.J., "Impact of Air Transportation on Regional Economic and Social Connectivity in the United States", AIAA Aircraft Technology, Integration, and Operations Forum, Los Angeles, CA, October 2002.