

# Axiomatic Design of a Customizable Pneumatic Automotive Suspension with Hydraulic Ride Height Regulator

by

Amy L. Wong

Mechanical Engineering 2005

SUBMITTED TO THE DEPARTMENT OF MECHANICAL ENGINEERING IN PARTIAL  
FULFILLMENT OF THE REQUIREMENTS FOR THE DEGREE OF

BACHELORS OF SCIENCE IN MECHANICAL ENGINEERING

AT THE

MASSACHUSETTS INSTITUTE OF TECHNOLOGY

The author hereby grants to MIT  
permission to reproduce and to  
distribute publicly paper and  
electronic copies of this thesis  
document in whole or in part

MAY 2005

[June 2005]

© Amy L. Wong. All Rights Reserved

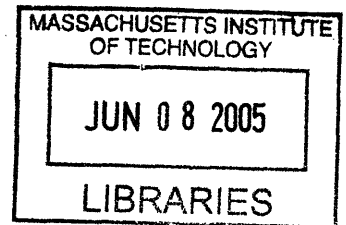

Signature of Author: \_\_\_\_\_

Department of Mechanical Engineering

May 05, 2005

Certified by \_\_\_\_\_

Nam P. Suh

Professor of Mechanical Engineering

Thesis Supervisor

Accepted by: \_\_\_\_\_

Ernest G. Cravalho

Professor of Mechanical Engineering

Chairman of the Undergraduate Thesis Committee

ARCHIVES

# **Axiomatic Design of a Customizable Pneumatic Automotive**

## **Suspension with Hydraulic Ride Height Regulator**

By

Amy L. Wong

Submitted to the Department of Mechanical Engineering on May 05, 2005 in Partial Fulfillment of the Requirements for the Degree of Bachelors of Science in Mechanical Engineering

### **Abstract**

Stiffness has long since governed the way people choose automobiles. Stiffer suspensions allow for the better handling necessary in sporty cars while softer suspensions provide the comfort expected in luxury cars. Automobiles have also been limited by ride height: a higher ride height will yield more clearance from bumps along the ground. However, lower ride height lowers the center of gravity of the car, which is desired for safety. The purpose of this work is to propose a way of using axiomatic design to devise a system that uses orifice controlled dampers, pneumatic springs and hydraulic chambers to achieve a fully customizable suspension system and ride height regulation. In addition, a way to create the best possible user experience is proposed by using control theory to keep the car chassis at the same level at all times, thus giving the user the ability to have a smooth ride at any suspension setting, even stiff suspension systems in the case of sporty car settings. To achieve the goals of this work, a short-long arm (SLA) suspension system was modeled and modified. The SLA suspension system is the most common front wheel independent suspension system that is used today. By keeping a similar overall design for the proposed system, adaptability of the proposed system is increased. The coil spring of the common SLA suspension system is replaced by an air spring with a fluid chamber in series. The air spring has a variable spring stiffness that is related to the volume of air inside. Because air is compressible, the volume changes with the force applied, yielding a nonlinear relationship that must be compensated for by an active control system that monitors the overall volume of the air spring and compensates for any changes during use by addition or removal of air. The fluid chamber is responsible for keeping the chassis at the same level at all times by taking into account the changing volume of the air spring and the changes in the road by having incompressible fluid pumped in and out of the chamber.

Thesis Supervisor: Nam P. Suh

Title: Professor of Mechanical Engineering

## **1.0 Introduction**

Vehicle stability has always been a coveted quality in the automobile industry, whether for safety or for comfort while riding. Current designs of suspension systems for cars have been religiously used for many years. The most basic method this is achieved in current automobiles is by using a passive suspension system in which springs and dampers are used to support the vehicle chassis. Depending on the type of car that the consumer is looking for, a different type of suspension system is used. For example, a race car would have a stiffer suspension in order to have more control on the ground and better handling, yielding a very uncomfortable ride, while a luxury car would have a very soft suspension to yield a much more comfortable ride, rendering their car unable to go very fast. The level of handling as a result of suspension stiffness is examined by Deo and Suh [2004]. As a second example, in terms of safety, the lower the car is to the ground, the lower the center of gravity for the car is, making the car safer. On the other hand, the lower the car is, the more prone it is to hit bumps that are along the ground, yet, in the case of going along a smooth highway, such a possibility would be low. Keeping these two examples in mind, a way to make the car a lot more versatile is to create a system in which the suspension and the ride height are adjustable. This would allow the consumer to “set” his car based on what mood he is in, whether it is going fast along a highway or taking his mother around for a nice ride. This work explores the possibility of creating an adaptive suspension system, which is a passive suspension system that is adjustable based on information input into the system. In addition, variable ride-height is also explored. Ride-height is officially defined as the distance between a specific point on the chassis to the ground. However, this work attempts to go further than maintaining a constant ride height but rather keeping the rider at the same level at all times, yielding the smoothest ride possible, regardless of suspension settings. A similar type of system was first proposed by Deo and Suh [2004]. In this work, however, instead of using traditional coil springs, air springs will be used with a hydraulic ride-height regulator to independently control stiffness and ride-height. The feedback control of this system is also explored. The design of this system will be governed by the principles of Axiomatic Design.

## **2.0 Introduction to Axiomatic Design**

Axiomatic Design is a design method that structures the design process in order to improve the process and the result by sorting crucial elements of the design to minimize the coupling of the design matrix, explained later in this section. Axiomatic Design consists of the four domains of design: customer, functional, physical, and process. These are represented by customer attributes [CAs], functional requirements [FRs], design parameters [DPs] and process variables [PVs]. In designing products, functional requirements must be translated into physical properties of product. In designing processes, physical properties must be translated into processes.

Satisfying functional requirements [FRs] is a major part of Axiomatic Design. The FRs are defined as the minimum set of independent functional needs that the product needs to satisfy. From the FRs, the key physical variables that characterize the design and satisfy the FRs are determined by the designer. These are called the design parameters [DPs]. Two design axioms guide the determination of the DPs:

1. Independence Axiom – Functional requirements must be independent of one another.
2. Informational Axiom – The information content of the design must be kept at a minimum.

To document the effect of DPs on FRs, a design matrix [DM] is used. The DM is also used to determine when design elements are coupled, decoupled, or uncoupled. It also shows when FRs can be satisfied and in what order DPs need to be determined. Below is an example of a DM:

$$\begin{Bmatrix} FR1 \\ FR2 \end{Bmatrix} = \begin{bmatrix} A_{11} & O \\ A_{21} & A_{22} \end{bmatrix} \begin{Bmatrix} DP1 \\ DP2 \end{Bmatrix} \quad . 1$$

$A_{11}$  denotes the effect of DP1 on FR1,  $A_{21}$  denotes the effect of DP1 on FR2, etc. In order to satisfy the Independence Axiom, the DM must be either diagonal or triangular. When the DM is diagonal, it is an uncoupled design. This means that each of the FRs can be satisfied independently by adjusting the corresponding DP. When the DM is triangular, it is a decoupled design. This means that the FRs can only be satisfied independently if the DPs are determined in a specific order. In the above example, to satisfy FR1 and FR2 independently, DP1 must be determined first, followed by DP2. In the case above, if the matrix is full (there is no “O”), then it becomes very difficult to satisfy the FRs because it is a coupled design.

The Information Axiom guides the designer to maximize the probability of satisfaction of the FRs. It becomes increasingly difficult to satisfy FRs when FRs are coupled by the chosen DPs.

### **3.0 Design of the Pneumatic Suspension System and Hydraulic Ride-Height Regulator**

Before delving into the design and modeling of the pneumatic adaptive suspension system and hydraulic ride height regulator, the kinematics of existing passive suspension systems was studied. Figure 1 shows a kinematic representation of the existing short long arm (SLA) suspension system. This work will be exploring a design that is based on the SLA, which is the most common front-wheel independent suspension system. A quarter-car single degree of freedom model (Figure 2) was then used to model the SLA suspension system

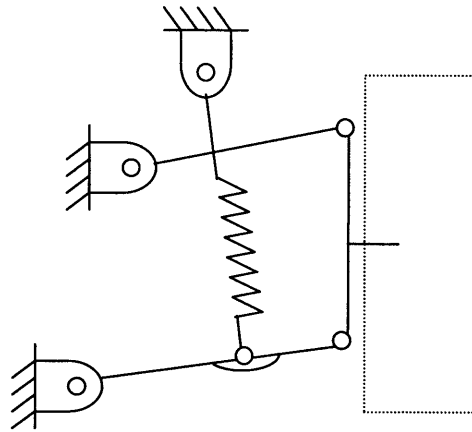

Figure 1: Kinematic representation of existing passive short long arm (SLA) suspension systems

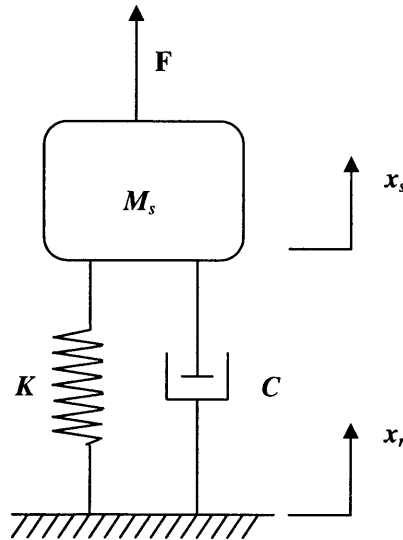

Figure 2: Quarter-car single degree of freedom model

Looking at Figure 2, we can obtain the following equation of motion:

$$M\ddot{x}_s = C(\dot{x}_r - \dot{x}_s) + K(x_r - x_s) + F \quad . 2$$

where  $M_s$  is the sprung mass,  $C$  is the damping coefficient, and  $K$  is the stiffness. The variables in the system are  $F$ ,  $x_s$ , and  $x_r$ .  $F$  represents any additional force that the suspension can feel. This can be a result of the load in the car or forces incurred during driving (for example, when the car is braked or turns a corner, there are forces generated on the wheels of the car).  $x_r$  and  $x_s$  represent the road disturbance and the subsequent response of the sprung mass to the road disturbance, respectively.

This work proposes the use of an air spring in the place of the coil spring in a conventional

suspension system, orifice control for damping variability, and the use of a hydraulic ride height regulator. The kinematic representation is shown in Figure 3.

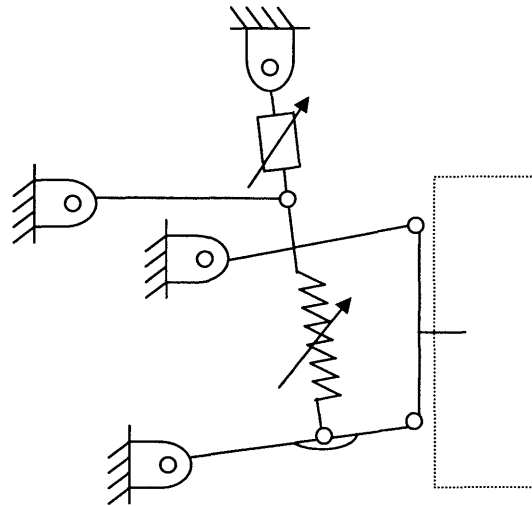

Figure 3: Kinematic representation of the proposed hydraulic adaptive suspension system with ride height regulation

The standard short long arm suspension design is maintained, allowing easy adaptability to current cars. As mentioned previously, the conventional coil spring is replaced by an adjustable air spring and a hydraulic ride height regulator is placed in series with the air spring. Figure 4 shows the same quarter-car single degree of freedom model adapted for the proposed design.

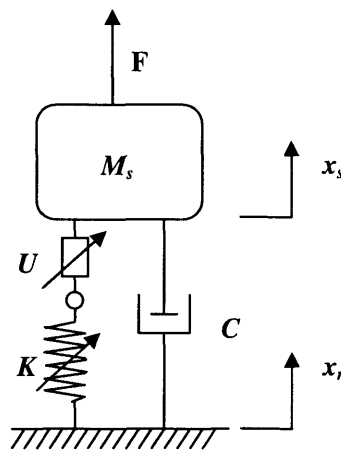

Figure 4: Quarter-car single degree of freedom model for proposed design

The user will be able to select from various ride settings that will in turn set a spring stiffness and damping coefficient that correspond to the selected ride setting. The ride height will also be user defined and maintained throughout the ride through bumps and other disturbances along the road to deliver the most comfortable ride possible.

### 3.1 Concept Development

In developing the concept proposed in this work, principles of axiomatic design were used to determine the functional requirements and constraints of a customizable, adaptive automotive suspension system with ride height regulation. The main functional requirement is to the customizability. This customizability leads to the user being able to control stiffness, damping, and ride height. These three are in turn functional requirements that define the product.

To satisfy the requirement of controlling stiffness (FR1), and air spring with adjustable volume will be used. A relationship between the spring stiffness and the volume of air inside the spring is obtained by modeling the air inside as an ideal gas. The derivation is described below.

Using the Ideal Gas Law:

$$P_o V_o^\gamma = P V^\gamma \quad . 3$$

where  $P$  is pressure,  $V$  is volume,  $P_o$  and  $V_o$  are the initial pressure and volume at time  $t_o$ .

$$F = dPA \quad . 4$$

and

$$F = kx \quad . 5$$

we can see that

$$k = \frac{dPA^2}{dV} \quad . 6$$

because

$$x = \frac{dV}{A} \quad . 7$$

and from differentiating

$$P = \frac{P_o V_o^\gamma}{V^\gamma} \quad . 8$$

$$\frac{dP}{dV} = P_o V_o^\gamma V^{-\gamma-1} (-\gamma) \quad . 9$$

we obtain

$$k = \frac{P_o V_o^\gamma \gamma (A^2)}{V^{\gamma+1}} \quad . 10$$

Looking back at Equation 3, we can see that Equation 10 can be simplified to

$$k = \frac{P\gamma(A^2)}{V} \quad . 11$$

Equation 11 directly relates spring stiffness to volume. The pressure is directly related to the sprung weight, which can vary depending on the load in the car.  $\gamma$  is the specific heat ratio, a constant that, in the case of air, is **1.4**.  $A$  is the cross sectional area of the air spring. Adjusting the volume of air in the air spring will affect the ride height. However, this can be compensated by the additional ride height control discussed below. The volume in the air spring will be the first design parameter, DP1, to be considered.

To provide damping variability (FR2), the existing technology of orifice control can be used. This will be the second design parameter, DP2, to be considered.

To satisfy the requirement of variable ride height (FR3), a fluid chamber is connected in series with the air spring. An incompressible fluid will be taken in and out of the fluid chamber to change the height of the car. The height of the fluid inside is dictated by the cross sectional area of the fluid chamber and the volume of incompressible fluid that is inside. This simple relationship is shown in Equation 12:

$$U_f = \frac{V_f}{A_f} \quad . 12$$

where  $U_f$  is the height of the fluid in the fluid chamber, which subsequently affects the ride height of the car,  $V_f$  is the total volume of liquid inside the fluid chamber, and  $A_f$  is the cross sectional area of the fluid chamber. The height of the fluid chamber will be the third design parameter, DP3, to be considered.

Taking the above FRs and DPs into consideration, we can obtain the following design matrix:

$$\left\{ \begin{array}{l} FR1 : Stiffness \\ FR2 : Ride - Height \\ FR3 : Damping \end{array} \right\} = \begin{bmatrix} X & O & O \\ X & X & O \\ O & O & X \end{bmatrix} \left\{ \begin{array}{l} DP1 : Volume of Air \\ DP2 : Height of Fluid Chamber \\ DP3 : Orifice Control \end{array} \right\} \quad . 13$$

From this design matrix, we can see that this is a decoupled system. As mentioned in Section 2.0, stiffness and ride-height can be varied independently if the design parameters are determined in the correct order. In this case, the Volume of Air (DP1) will need to be determined before the Height of the Fluid Chamber (DP2). We can also see that control of damping is completely independent of the other functional requirements. The orifice control design parameter is also completely independent. Because of these reasons, the orifice control and damping can be excluded from the rest of the system analysis in the remainder of this work as it does not affect the stiffness or the ride-height.



### 3.2 Nonlinearity of Air Spring

In evaluating the performance of the air spring, however, one must realize that air springs do not operate linearly. Again using the Ideal Gas Law:

$$P_1V_1^\gamma = P_2V_2^\gamma = \text{const} \quad . 14$$

we see that pressure has a nonlinear relationship with volume, which in turn makes spring stiffness have a nonlinear relationship with pressure:

$$P = \frac{\text{const}}{V^\gamma} \quad . 15$$

Graphing this in Matlab, we can see the nonlinear relationship graphically:

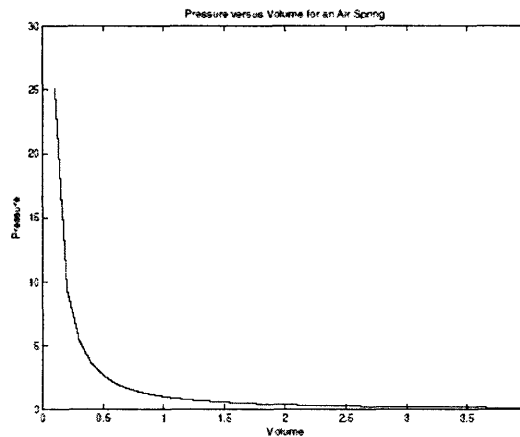

Figure 5: Pressure vs. Volume for an air spring

As we can see from, the air spring is highly nonlinear, meaning that with a slight change in pressure (from the force) can yield a very large change in spring stiffness (from the volume). Because of this, it is necessary to continuously monitor the force applied to the spring and regulate the volume of the air in the spring to maintain constant spring stiffness during ride. This will be accomplished by a control loop that will be explored later on in this work. However, in order to obtain a viable control loop analysis for the control of this system, software implementation of the nonlinear spring equation will be used.

### 3.3 Obtaining Equations of Motion

Looking back at Equation 10, we can consolidate the constant terms into one overall constant:

$$k = \frac{const}{x^{\gamma+1}} \quad . 16$$

Using  $F=kx$  and substituting Equation 16 for  $k$ , we get

$$F = \frac{const}{x^{\gamma}} \quad . 17$$

or, the spring force is a function of the inverse of  $x^{\gamma}$ .

With the above in mind and looking at Figure 4, we can obtain the following equation of motion for the proposed design:

$$M_s \ddot{x}_s = F + \frac{const}{(x_s - x_r)^{\gamma}} - C(\dot{x}_s - \dot{x}_r) \quad . 18$$

where  $M_s$  is the sprung mass and  $C$  is the damping coefficient. As is with the original SLA model studied in Section 3.0, the variable parameters are  $F$ ,  $x_s$ , and  $x_r$ . However, in this case,  $K$  is also variable.

### 3.4 Physical Design of Proposed System

To accomplish the tasks necessary for the proposed system, a physical design has been developed for the potential prototyping of the proposed SLA system.

In order to vary the air inside the air spring, a compressor and filter system will be used to extract ambient air and filter and compress it to the necessary pressure to be pumped into the air spring when a larger volume of air is necessary. There will be two check valves on the air spring that can be opened and closed to regulate the air flow. When a smaller volume of air is desired in the air spring, then the check valve to atmosphere will be opened to release the necessary amount of air.

To vary the volume of the incompressible fluid in the fluid chamber, a fluid reservoir will be used to hold excess fluid that will be pumped in and out of the fluid chamber when necessary. A schematic of the fluid chamber system and the air spring are shown below.

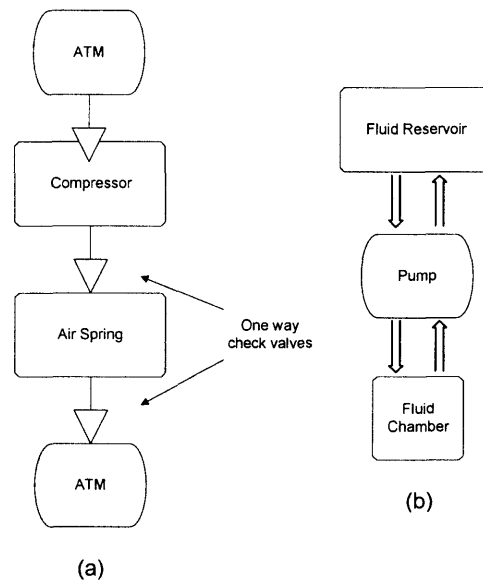

Figure 6: Schematic of the physical design of the proposed (a) hydraulic ride height regulator and (b) pneumatic air spring.

#### 4.0 System Control

As seen in the functional requirements described in Section 3.1, several system attributes must be monitored in order to determine spring stiffness and ride height at any point in time. To determine stiffness, the volume of air in the air spring must be measured. In determining the total ride height, however, three parameters must be measured, the volume of incompressible fluid in the fluid chamber, the volume of the air spring, and the relation of the wheel to the body of the car. Visiting Figure 3, we can see that the height relationship between the wheels of the body to the car can be determined by measuring the angles in the SLA suspension as illustrated in Figure 6 by angle  $\theta_1$  and the volume of the air spring can be determined using a geometrical relationship between  $\theta_1$  and  $\theta_2$ .  $\theta_2$  can also be used to determine the volume of the incompressible fluid in the fluid chamber by measuring the amount the fluid chamber has extended or shortened.

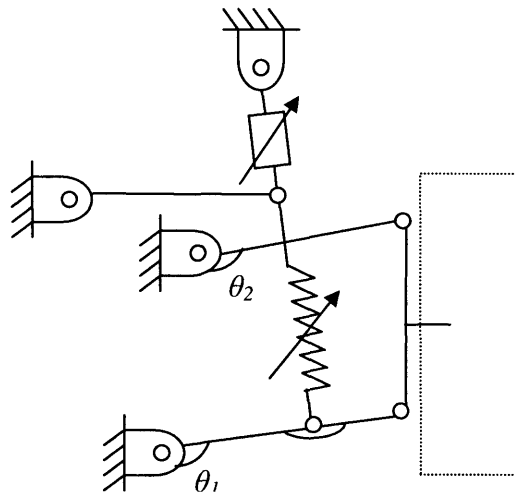

Figure 7: The height relationship of the wheel to the body of the car can be determined by  $\theta_1$ .

Using simple geometry, we can see that  $\theta_1$  is related to the height of the wheel and  $\theta_2$  is related to the height of the fluid chamber by the following equations:

$$height_{wheel} = const_1 \cdot \sin \theta_1 \quad . 19$$

$$height_{fluidchamber} = const_2 \cdot \sin \theta_2 \quad . 20$$

where the constants are a function of the geometry (ie, the length of the linkages, etc). Equation 19 can be used to directly measure the volume of the air spring as well if  $\theta_2$  is known. This is the result of the sequence of events described in Section 3.1 where the variable properties of the spring must be determined before the variable properties of the fluid chamber to maintain the system's decoupled status. Because of this sequence of events,  $\theta_2$  can be modeled as a stiff joint and any displacement in  $\theta_1$  is the result of the compression or extension of the spring.

Revisiting Figure 4, we see a clearer representation of how the fluid chamber and air spring contribute to the total ride height (Figure 7)

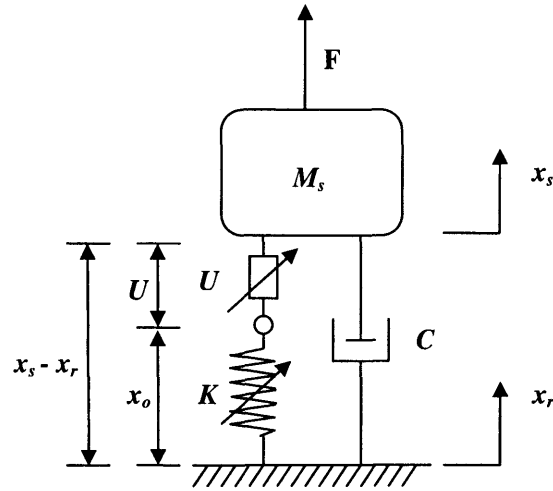

Figure 8: A clearer representation of the effect the fluid chamber and air spring have on total ride height

$x_s - x_r$  represents the total ride height of the car,  $U$  represents the height of the fluid chamber, and  $x_o$  represents the height of air spring, also variable because the volume of the air inside the air spring is variable.

A combination of Equations 12 and 19 yield the total ride height for the car while not in motion:

$$TotalHeight = \frac{V_f}{A_f} + \frac{V_s}{A_s} + const_1 \cdot \sin \theta_1 \quad .21$$

where subscript  $f$  denotes the values for the fluid chamber and subscript  $s$  denotes the value for the air spring.

In motion, however,  $x_r$  must be taken into account. Looking at Equation 21 and combining Equations 19 and 20, we obtain the following equation for Total Height desired:

$$Height_{Desired} = x_r + const_1 \cdot \sin \theta_1 + const_2 \cdot \sin \theta_2 + const_3 \quad .22$$

where the user inputs the  $Height_{desired}$  and  $const_3$  is again due to the geometry of the system.

During car operation, the parameter that changes will be  $\theta_1$  due to  $x_r$ . By measuring  $\theta_1$  during operation, determining and compensating for the change in volume in the air spring, and concurrently adjusting the volume of the fluid in the fluid chamber ( $V_f$ ), then a level ride height can be achieved, minimizing the discomfort the rider will feel in the car, subsequently maximizing comfort. Because variation in the ride height does not affect the stiffness of suspension, this design will enable maximum comfort for the user while giving the user the level of handling he or she desires.

To achieve the proposed stiffness variation and ride height regulation, two main control loops are necessary (Figure 9 and 10). Equations 19 and 20 were used to derive the transfer functions for the plants

for each control loop, respectively.

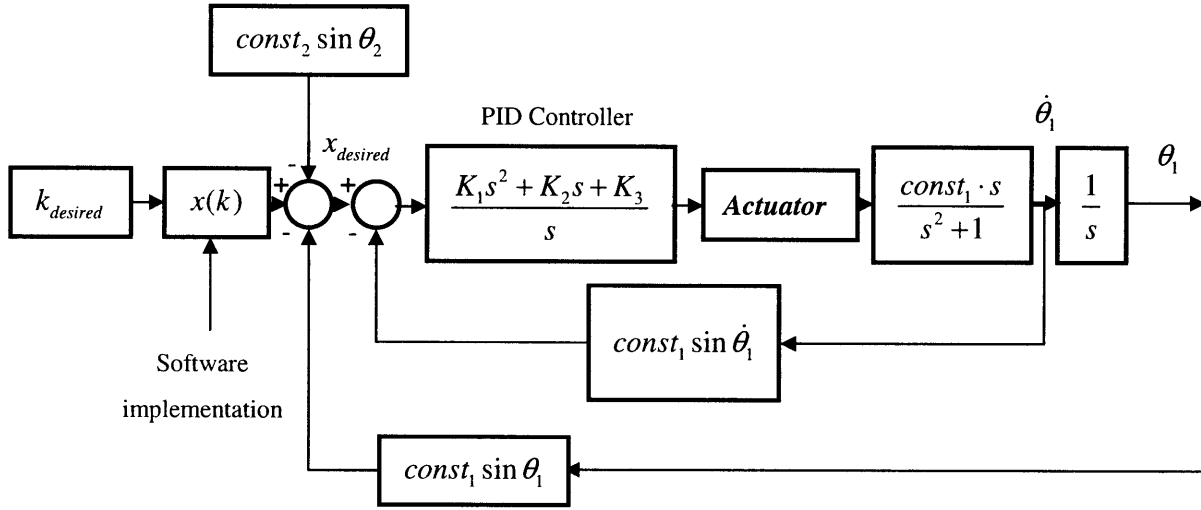

Figure 9: The proposed control loop for the air spring

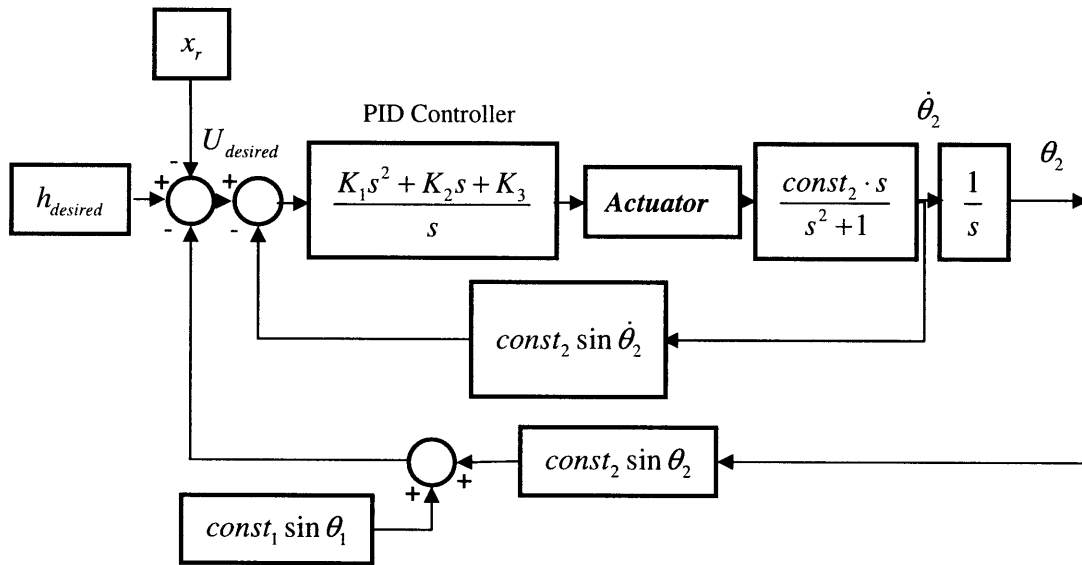

Figure 10: The proposed control loop for the fluid chamber

These two control loops can operate independently, but as stated previously, the spring must be determined before the fluid chamber to maintain the decoupled status of the system. For the air spring loop, the extension of the fluid chamber ( $\theta_2$ ) is inputted in order to determine the volume of the air spring. If the volume has deviated from the desired volume for the desired spring constant, the first adder will yield a non-zero value to be inputted into the embedded loop to be compensated for. Similarly, the control loop for the fluid chamber takes in all the components that contribute to the total height, including the

ground,  $x_r$ , and the total height is different from the desired height, there will be a non-zero value that travels through to the embedded loop to be compensated for.

The actuators for both loops stand for the equation models for the compressor, pump, and control valves that are proposed in section 3.4. An example of a way to model the actuator for a compressor would be to model the induction motor in the compressor.

## 5.0 Conclusion

This paper proposes a way to independently control stiffness, ride height, and damping to provide a truly customizable automobile riding experience. The versatility of axiomatic design as a design tool is also illustrated by its application to this design problem, yielding a design that minimizes coupling and standardizing the design process.

In addition to allowing variability of stiffness, ride height, and damping, this work proposes a method to create the best driver experience possible by allowing for multiple suspension settings while keeping the car chassis relatively level, allowing the user to have the handling he or she desires while still having an overall smooth ride.

The use of air springs in lieu of coil springs in suspension systems has gained popularity in recent years. However, due to their nonlinearity, various methods of linearizing have been attempted. In this paper, a software implementation was used as an alternative solution this problem.

## 6.0 References

1. Anakwa, Winfred K.N. (Dept. of Elec. and Comp. Eng., Bradley University); Thomas, Dion R.; Jones, Scott C.; Bush, Jon; Green, Dale; Anglin, George W.; Rio, Ron; Sheng, Jixiang; Garrett, Scott; Chen, Li, "Development and control of a prototype pneumatic active suspension system", **IEEE Transactions on Education**, v 45, n 1, February, 2002, p 43-49
2. Cronje, Johan M.; Heyns, P. Stephan; Theron, Nico J.; Loveday, Philip W., "Development of a Variable Stiffness Spring for Adaptive Vibration Isolators", *Proceedings of SPIE - The International Society for Optical Engineering*, v **5386**, **Smart Structures and Materials 2004 - Damping and Isolation**, 2004 p. 33-40
3. Deo, Hrishikesh; Suh, Nam P; "Axiomatic Design of Automobile Suspension and Steering Systems: Proposal for a novel six-bar suspension", **SAE International**, 2003
4. Deo, Hrishikesh; Suh, Nam P; "Axiomatic Design of Customizable Automotive Suspension", **The Third International Conference on Axiomatic Design**, 2004
5. El-Tawwab, All M. Abd (Minia Univ); Abou-El-Seoud, S.A., "Theoretical study of the hydro-pneumatic semi-active suspension system with preview", **Heavy Vehicle Systems**, v 5, n 2, 1998, p 167-180
6. Jettapa, Richard Rodrigues, "Asymmetric Response of a Pneumatic Spring", **Machinery Dynamics and Element Vibrations**, v. 6, 1991, p. 91-96
7. Kornhauser, A. A., "Dynamic Modeling of Gas Springs", **Proceedings of the Intersociety Energy Conversion Engineering Conference**, v5, 1991, p. 176-179
8. Kroeker, P. (Vansco Electronics Ltd.); Habibi, S.; Burton, R. "Modeling of a novel fan clutch pneumatic actuation system", **IEEE/ASME International Conference on Advanced Intelligent Mechatronics**, AIM, v 1, 2001, p 422-427
9. Vantsevich, Vladimir V. (Mechanical Engineering Department, Lawrence Technological University); Lomako, Gennady; Opeiko, Alexandre, "Interaction Between Autonomous Vehicles and Road Surface", **International Journal of Vehicle Autonomous Systems**, v 1, n 3-4, 2003, p 291-308
10. Yoshimura, T. (Department of Mechanical Engineering, Faculty of Engineering, University of Tokushima); Hiwa, T.; Kurimoto, M.; Hino, J., "Active suspension system of a one-wheel car model using fuzzy reasoning and compensators", **International Journal of Vehicle Autonomous Systems**, v 1, n 2, 2003, p 196-205
11. Yoshimura, Toshio (Univ of Tokushima); Kubota, Hirofumi; Takei, Kazuyoshi; Kurimoto, Masao; Hino, Junichi, "Construction of an active suspension system of a quarter car model using fuzzy reasoning based on single input rule modules" **International Journal of Vehicle Design**, v 23, n 3-4, 2000, p 297-306