

**Design of a Bias-Weaving Machine:
Thread Manipulation and Other Topics**

by

Jonathan D. Rohrs

Submitted to the Department of Mechanical Engineering
in partial fulfillment of the requirements for the degree of

Master of Science in Mechanical Engineering

at the

MASSACHUSETTS INSTITUTE OF TECHNOLOGY

September 2003

© Massachusetts Institute of Technology 2003. All rights reserved.

Author

.....
Department of Mechanical Engineering

Certified by ..

.....
Samir Nayfeh
Assistant Professor
Thesis Supervisor

Accepted by

.....
Ain A. Sonin
Chairman, Department Committee on Graduate Students

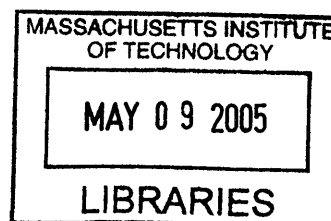

BARKER

**Design of a Bias-Weaving Machine:
Thread Manipulation and Other Topics**

by

Jonathan D. Rohrs

Submitted to the Department of Mechanical Engineering
on August 8, 2003, in partial fulfillment of the
requirements for the degree of
Master of Science in Mechanical Engineering

Abstract

A machine for producing bias weaves (thick, multiaxial weaves) is presented. It consists of a fill/warp weaving apparatus superimposed on a general braiding machine. The braiding machine consists of a set of moveable columns which hold spools of bias fibers, and a mechanism to shift spools from one column to the next. Jacquard-movable warp fibers run between the columns. This machine allows the use of a beat-up mechanism that does not need to be removed from the weave. A large set of braids which are produceable on the proposed bias-weaving machine are described, along with the machine operations required to produce them.

The design of a tension-regulating thread package for use in this bias-weaving machine is also presented. This mechanism can take-up a finite amount of thread and is insensitive to friction variations. The design was chosen based on the systematic development and elimination of alternative designs. It may be easily adapted to other uses—a shuttle is given as an example.

Thesis Supervisor: Samir Nayfeh

Title: Assistant Professor

Acknowledgments

I would first like to thank my advisor, Professor Samir Nayfeh. His guidance, encouragement, perspective, and occasionally-infectious enthusiasm for engineering has been essential during this project. I would also like to thank the other students (and the postdoctoral researcher) who worked on this project: Dr. Osamah El Rifai, Sappinandana Akamphon, Mauricio Diaz, and Emily Warmann. They each have contributed some very hard work and very late nights. Thanks also to Mark Belanger and Gerry Wentworth for their help in the LMP shop, and to Bally Ribbon Mills for sponsoring this project.

Many people have contributed to my broader life here in Cambridge during this time, but Paul Nicholson and Rajay Kumar, two of my friends (and my roommates during this period), deserve special credit. And my parents, constantly supportive, to who I owe so much.

Contents

1	Introduction	17
1.1	The Bias-Weaving Project	20
1.2	Notes on Drawings and Terminology	20
2	Motivation	21
3	Braids	25
3.1	Artin's Theory of Braids	25
3.1.1	Definition of a Braid	26
3.1.2	Equivalence	26
3.1.3	Braid Projections	26
3.1.4	Description of a Braid	28
3.2	Basic Conclusions about Braids	30
3.2.1	3D Braids vs. Flat Braids	30
3.2.2	Twist	32
3.2.3	Complete Braid Descriptions	34
3.2.4	Sub-Braids	34
3.2.5	Necessity of Passable Thread Packages	34
3.2.6	Identity-Braid Textiles	35
3.2.7	Number of Required Passable Thread Packages	36
3.2.8	Requirement for a General Braiding Machine	36
3.3	Biaxial Weaves	36
3.3.1	$0^\circ/90^\circ$ Weaves	37

3.3.2	Specialized Braid Description for $0^\circ/90^\circ$ Weaves	37
3.3.3	Biaxial Subweaves	39
3.4	Compound Braids	39
3.5	Braid Qualities, Besides Topology	41
4	Braiding Machines	43
4.1	Weaving Machines	43
4.2	Multiaxial-Weaving Machines	43
4.2.1	Identity-Braid Machines	44
4.2.2	Carousel-Type Machines	45
4.2.3	Fill and Beat-up Problems	48
4.3	Braiding Machines	51
4.3.1	Horn-gear Machines	51
4.3.2	The 3D-Solid Machine	51
4.3.3	Cartesian Braiding Machines	53
4.3.4	The Two-Step Braiding Machine	54
4.4	Beat-Up	56
4.5	A General Braiding-Machine Model	56
4.5.1	Usefulness?	58
4.5.2	An Alternative Model	59
4.6	A Flat Braiding Machine	59
5	The Proposed Machine	61
5.1	Suggestions for Design	61
5.1.1	Geometric Similarity with the Braid	61
5.1.2	Specialized Thread Movements for Specialized Threads	64
5.1.3	Pass Spools in Front of Reed Blades	66
5.2	The Concept	66
5.2.1	Bias-Package Shifting	67
5.2.2	Filling	71
5.2.3	Beat-Up	72

6	Braiding on the Proposed Machine	73
6.1	Elementary Braids	74
6.2	Simple Bias-Bias Subweave Patterns	76
6.2.1	Limitations in Simple Bias-Bias Subweaves	79
6.3	Compound Bias Subweaves	80
6.3.1	Shift Planning	81
6.3.2	Limitations in Compounding	83
6.4	The Bias-Warp Subweaves	84
6.5	The Bias-Fill Subweave	84
6.6	Axial-Bias-Fill Restrictions	85
6.7	A Criteria for Braidability	87
6.8	Cross-Section Representation	87
6.9	Multiple Shifting Rows	88
7	Comparisons and Conclusions	91
7.1	Manipulation of Thread Ends	91
7.2	Specialized Mechanisms for Specialized Braids	92
7.3	Different Threads Roles	93
7.4	Warp Threads	93
7.5	Correlations in Thread Movements	94
7.6	Geometry on the Braiding Plane	95
7.7	Non-Passing Movements	96
7.8	Crossing Multiple Threads Simultaneously	98
7.9	Putting the Reed Behind Passing Threads	98
7.10	The Main New Features	99
8	Abstract Bias-Package Design	101
8.1	Functional Requirements	102
8.1.1	Thread Capacity	102
8.1.2	Tension Control	102
8.1.3	Take-Up	103

8.1.4	Size	103
8.1.5	Other Requirements	104
8.2	Choice to Use Springs	104
8.3	Tensioning Using Releasing Elements	104
8.3.1	The Releasing Element	105
8.3.2	Ways of Using the Releasing Element	105
8.4	Types of Releasing Elements	107
8.4.1	Force Release	107
8.4.2	Displacement Release	109
8.5	Dynamic Response: Eliminating Series 1	109
9	Tensioner Design, Round 1	111
9.1	Rotary Displacements to Thread Displacements	111
9.1.1	Restrained Spool	112
9.1.2	Squeeze Roller with Guides	112
9.1.3	Squeeze with Shaped Roller	113
9.1.4	Variations on the Squeeze Roller	113
9.2	Tensioner Designs	115
9.2.1	Design 1: Force Release Using Friction	115
9.2.2	Design 2: Displacement Release Using Friction	116
9.2.3	Design 3: Displacement Release Using an Escapement	117
9.2.4	Design 4: Rotary Parallel Displacement-Release	118
9.2.5	Design 5: Linear Parallel Displacement-Release	119
9.3	Friction-Insensitive Force Release	120
10	Tensioner Design, Round 2	123
10.1	Spool Styles and Pay-off Methods	123
10.2	Tensioner Designs	124
10.2.1	Design 6: Force Release, Restrained Spool	124
10.2.2	Design 7: Force Release, Squeeze Roller	127
10.2.3	Design 8: Displacement Release, Shaped Squeeze	129

10.2.4 Design 9: Displacement Release, Nonrotational	133
11 Final Tensioner Design, Comparisons	137
11.1 Problems with Slack Thread	137
11.1.1 Guiding	137
11.1.2 Shaped Rollers	139
11.1.3 Multiple Wraps	139
11.2 Displacement-Release with a Restrained Spool	140
11.3 Final Design	140
11.4 Summary of the Design Process	143
11.5 Shuttle	144
11.6 Adjustable Tension	145
11.7 Comparisons with Prior Art	146
12 The Braiding Machine, As Built	151
12.1 Practical Notes on Bias Weaving	155
12.2 Example Weaves	155

List of Figures

1-1	A Bias Weave	17
2-1	Some Loads on the Wing Spar	22
2-2	Current Design of the Skin-Wing Connection	22
2-3	Weave Deformations	23
3-1	An Example Braid, β_{ex}	27
3-2	A Braid Projection of β_{ex}	27
3-3	Braid Multiplication: $\beta_2\beta_1 = \beta_{ex}$	28
3-4	Inverse of β_{ex}	29
3-5	Some Elementary Braids	29
3-6	Braid Word: $\beta_{ex} = \sigma_2^{-1}\sigma_1\sigma_3^{-2}\sigma_2^{-1}\sigma_1$	30
3-7	A Three Dimensional Braid, Mapped to β_{ex}	31
3-8	Strings Moving in the Braid Cross-Section	32
3-9	An Identity-Braid Textile	35
3-10	A Weave Projection and Side Cross-Section	37
3-11	Binary Representation of the Weave	38
3-12	Fill Representation of the Weave	38
3-13	Bias Subweave Projections	40
3-14	Example Compound Bias Weave	41
4-1	Identity-Braid Bias-Weaving, Top View. Drawing from [5]	44
4-2	Identity-Braid Bias Weave. Drawing from [5]	45
4-3	Carousel-Type Loom, Side View. Drawing from [27]	46

4-4	Carousel-Type Loom, Top and Front View. Drawing from [27]	47
4-5	Filling on Identity-Braid Machine, Side View. Drawing from [5]	49
4-6	Filling and Beat-Up on Carousel-Type Machine. Drawing from [27]	50
4-7	Horn-gear-Type Braiding Machine. Drawing from [10]	52
4-8	The 3D-Solid Braiding Machine. Drawing from [16]	53
4-9	Cartesian Braiding Machine. Drawing from [17]	54
4-10	Two-Step Braiding Machine. Drawing from [13]	55
4-11	Insertion-Type Beat-Up Mechanism. Drawing from [6]	57
5-1	Bias End Outside the Weave, Advancing the Bias Fiber	62
5-2	Bias End Outside the Weave, Filling	63
5-3	The Machine Concept, Isometric View	67
5-4	The Machine Concept, Top View	68
5-5	The Bias Shed	68
5-6	Shifting the Bias Packages	69
5-7	Schematic Diagram Key	69
5-8	Schematic of Bias Shifting	70
5-9	Another Schematic of Bias Shifting	71
5-10	Fill Shed	71
5-11	Passing the Shuttle	72
5-12	Fill Schematic	72
6-1	Producing an Elementary Braid	75
6-2	Example Bias-Shifting Process	77
6-3	Bias-Shifting Process Result	78
6-4	Bias-Shifting Process Result, Straightened	78
6-5	Example Process Schematic	78
6-6	The Coupling Problem	79
6-7	A Way to Fix the Coupling Problem	80
6-8	A Compound Bias-Weave Process	81
6-9	Shift Planning Diagram	82

6-10	A Convenient Shifting Method	82
6-11	Another Convenient Shifting Method	83
6-12	The Same-Direction Crossing Problem	84
6-13	Impossible Weave	85
6-14	Impossible Weave, Stationary Threads Darkened	86
6-15	Cross-Section Representation of a Bias Weave	88
6-16	Shifting Two Adjacent Rows	89
6-17	Shifting Two Non-Adjacent Rows	89
7-1	The Highest-Level New Features of the Machine	99
8-1	Ways of Using the Releasing Element	106
8-2	The Possible Abstract Tensioning Mechanisms	108
9-1	The Restrained Spool	112
9-2	Squeeze Roller with Guides	113
9-3	Squeeze with Shaped Roller	114
9-4	Variations on the Squeeze Roller	114
9-5	Force-Release Using Friction	115
9-6	Displacement-Release Using Friction	117
9-7	Displacement-Release Using an Escapement	118
9-8	A Parallel Displacement-Release Design	119
9-9	Another Parallel Displacement-Release Design	120
9-10	Friction-Insensitive Force Release	121
9-11	Mechanism as Mechanical Feedback System	121
10-1	Some Spool Styles and Pay-off Methods	124
10-2	Bias Package 1: Isometric Views	125
10-3	Bias Package 1: Section View	126
10-4	Bias Package 2: Isometric Views	128
10-5	Bias Package 2: Section Views	128
10-6	Bias Package 3: Isometric Views	129

10-7	Bias Package 3: Section View	130
10-8	Bias Package 3: Escapement Operation	130
10-9	Bias Package 3: Spool Loading, Not Actual Size	132
10-10	Bias Package 4: Isometric Views	135
11-1	Problems with Guiding Slack Threads	138
11-2	Close Guide	138
11-3	Problems with Shaped Rollers	139
11-4	Problems with Multiple Wraps	140
11-5	Final Design, Isometric View	141
11-6	Final Design, Side View	142
11-7	Shuttle, Side View	144
11-8	Shuttle, Top View, Opened	145
11-9	Non-Retracting Tensioning Method. Drawing from [26]	146
11-10	Retracting Tensioning Mechanism. Drawing from [14]	147
11-11	Displacement-Release Tensioning Mechanism. Drawing from [18]	148
11-12	Friction-Based Displacement Release. Drawing from [23]	149
12-1	The Bias-Weaving Machine, As Built	152
12-2	The Column Array	153
12-3	Bias Packages	154
12-4	Example Weave A	156
12-5	Picture of Example Weave A	156
12-6	Example Weave B	157
12-7	Picture of Example Weave B	158
12-8	Example Weave C	159

Chapter 1

Introduction

A bias weave is a multiaxial weave such as the weave shown in Figure 1-1. The typical case, shown, has threads at 0° (warp), 90° (fill or weft), $+45^\circ$ (left-moving bias), and -45° (right-moving bias). Although the example shown is essentially flat, other weaves may be more three dimensional.

Such a weave is useful because, unlike standard weaves, it can sustain shear forces by using the $+45^\circ$ and -45° yarns. It is a more isotropic textile than standard weaves. Chapter 2 discusses how these properties can be put to use in a specific, motivating application. The drawback to bias weaves is that they cannot be manufactured on standard weaving machines, for rather fundamental reasons.

To produce a particular bias weave, or any other braid, a machine do two things: It must move the threads relative to each other in such a way that the product is topologically

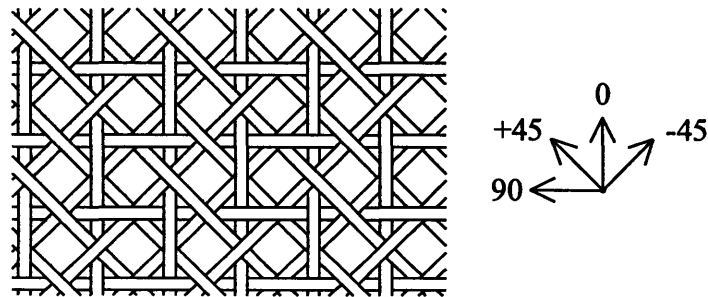

Figure 1-1: A Bias Weave

correct. It must also ensure the threads are geometrically correct—they must have the proper alignment, crimp, etc. Correct topology is a prerequisite for correct geometry, and is also easier to predict. The geometric configuration of threads will be affected by many difficult-to-characterize parameters such as thread tension, beat-up processes, and friction. Topology, on the other hand, depends only on how threads are moved relative to each other.

For these reasons, topology is a useful starting point for designing braiding machines. This thesis will propose a machine to produce bias weaves, and justify its design largely—but not exclusively—from a topological standpoint. To do this, it would be helpful to know something about braids and how they relate to the machines that produce them. More specifically, one would like to know things such as

- How one describes a three-dimensional braid.
- What aspects of a braiding machine are important to braiding.
- Which braids can be produced on a given machine.
- Which machines can produce given sets of braids.
- Which braiding machine is the best.

Artin's theory of braids is presented in Chapter 3. This will concretize what is meant by a braid and what information is necessary to describe it. It is only one way of viewing braids; for some purposes it is useful, for some other purposes it is an awkward basis. It will be useful, for instance, in indicating some fundamental restrictions that the machine structure imposes on the braid. Chapter 3 also explores ways of examining constituent parts of complicated braids, and ways of building up complicated braids from simpler parts. This is moving away from Artin's topological description to a more geometrically-based description, although no complete alternative description of braids is presented.

Chapter 4 presents some example braiding machines. It can be seen that they are all variations on a common structure. One can find, in the details of this structure, all the information that describes which braids can be produced on a given machine. Unfortunately, it is not necessarily easy (or possible) to extract this information in a meaningful way.

The other questions—which machines can produce given braids, and what machine is best—are less useful to answer, or are more difficult to address, partially because they are less well-defined. For instance, in order to truly judge the best machine, one would need to know exactly what braids need to be produced. These may not be known. One would also need some criteria for judging machine performance. This is likely to include matters of cost, mechanical complexity, and speed. All of these things depend on all the mechanical details of the machine, so the question is probably intractable. Similarly, it may not be useful to generate braiding machines based on which braids they can produce, since the machines' usefulness depends on so many other factors.

Instead, the approach taken here is to simply propose a bias-weaving machine, in Chapter 5. This choice is not random, it is educated by fundamental considerations of braiding requirements and mechanical feasibility. The choice is then justified by verifying that it can efficiently produce a wide variety of desirable braids, in Chapter 6.

This is done by describing a few basic, efficient braid patterns; and then describing ways that they can be combined to form more complicated braids. This constructive approach identifies many bias weaves that may be efficiently produced on the proposed machine, enough to show that the machine can efficiently manufacture most (or all) of the desired braids. This strategy avoids the problem of braids that the machine can only slowly manufacture, although these are discussed as well. The proposed machine is compared to existing machines in Chapter 7.

Chapters 8–11 cover the design of a bias-thread package, which contains the bias spool and a tensioning system. Although such a passable thread package is (as shown in Chapter 3) a necessary part of braiding machines, these chapters are independent of the other chapters. The design was chosen based on the systematic development and elimination of alternative designs. Although the tensioning mechanism design was developed for the bias-thread package, it may be easily adapted to other uses. A shuttle is given as an example. The chosen mechanism is also compared with existing tensioning methods.

This bias-weaving machine was built. Photos of it and a braided product are included in Chapter 12.

1.1 The Bias-Weaving Project

This bias-weaving machine was developed in a project involving Professor Samir Nayfeh, Dr. Osamah El Rifai, Sappinandana Akamphon, Mauricio Diaz, Emily Warmann, and myself. The project was sponsored by Bally Ribbon Mills (Bally, PA). The bias-weaving machine concept is presented here at a fairly high functional level: the machine's basic structure, how the bias spools are arranged on it, where the spools move. The details of the structure and mechanisms to move the spools and other machine parts are not covered, as they are largely separate problems. Some of these details, for this same machine, are presented in the theses by the other students who worked on this project [1, 4, 29]. In the future, there may also be a patent with more information.

1.2 Notes on Drawings and Terminology

All braids are drawn as if the braiding machine is located towards the top of the page, as if the braided material were moving toward the reader as it is produced. On the tensioning mechanism diagrams: cut-away pieces may turn freely on their axles, unless otherwise noted.

The words “thread”, “yarn”, and “fiber” are usually used interchangeably to mean a thin, string-like object, whether or not they are composed of filaments or are a single strand. Cases where fiber is intended to mean a filament that is part of a larger thread should be clear from the context.

“Braid” is used as a general term that encompasses both woven materials and what one might normally call a braid. When not preceded by the word “bias”, a “weave” typically means a $0^\circ/90^\circ$ textile—a specific, specialized type of braid—but occasionally it may also refer to whatever textile a machine is producing, such as a bias weave.

The words “twist”, “sub-braid”, “subweave”, “compound braid”, and “thread package” have been adopted for naming concepts that did not seem to otherwise have names. They are not standard terminology, and their meaning may deviate from standard usage. A thread package is the self-contained object that contains a thread end. It likely also contains a spool for the thread and some tensioning mechanism. A shuttle is an example of a thread package.

Chapter 2

Motivation

The machine proposed in this thesis addresses the problem of producing the textile preform for the composite part used to bind the skin to the spars in an airplane wing. This is a typical example of a more general problem in composites manufacture.

A schematic drawing of the parts to be joined is shown in Figure 2-1. The spar and wing skin are essentially two perpendicular intersecting plates which, in reality, are longer than shown. The arrows indicate how the spar will be pulled relative to the skin: the parts are both pulled apart and sheared relative to each other. The composite part must be strong and stiff under those loadings.

Currently, this joining problem is solved using the parts shown in Figure 2-2. A pi-shaped (or sometimes T-shaped) woven preform is used to join the two wing components. This part only contains vertical and horizontal threads; the vertical threads directly take the forces that tend to pull apart the two wing components, while the horizontal threads simply hold the part together until it is epoxied (they remain in place afterwards). The part can only have these two sets of threads because it is woven on a standard loom. During weaving, the vertical legs are folded down, so the part lies flat.

The pi-shaped part, by itself, cannot effectively support the shear stresses. Figure 2-3 illustrates the reason for this. Stretching a $0^\circ/90^\circ$ weave requires stretching the threads (or removing some crimp). Shear, however, can simply deform the weave without stretching. This means that applications which tend to shear the composite must rely on the strength and stiffness of the resin, not the relatively-strong threads.

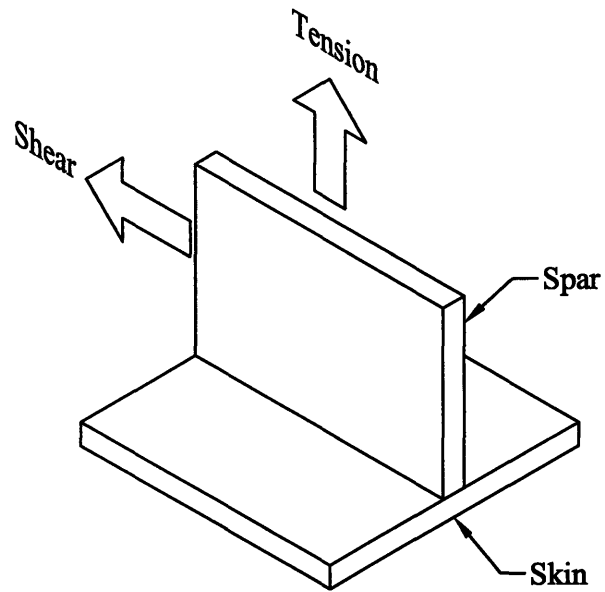

Figure 2-1: Some Loads on the Wing Spar

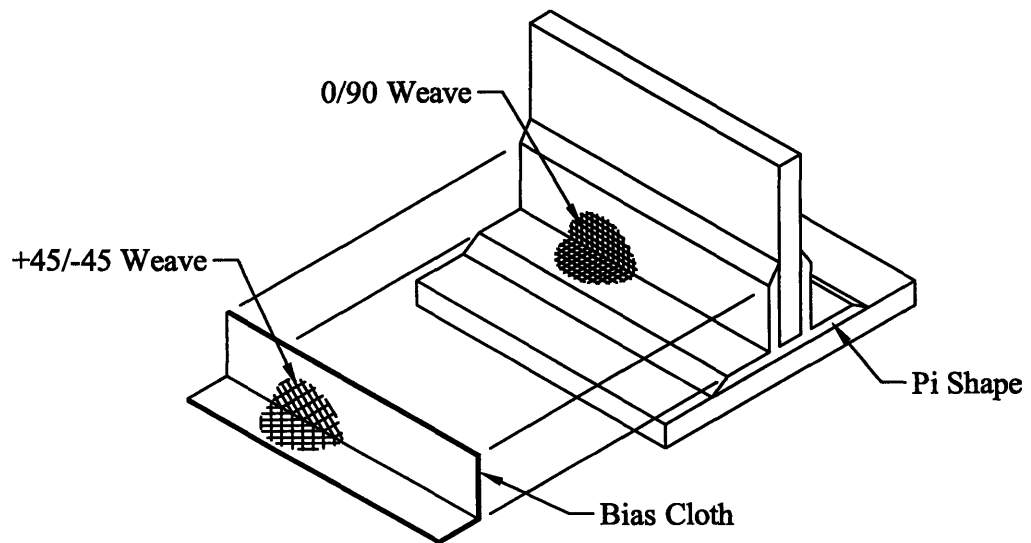

Figure 2-2: Current Design of the Skin-Wing Connection

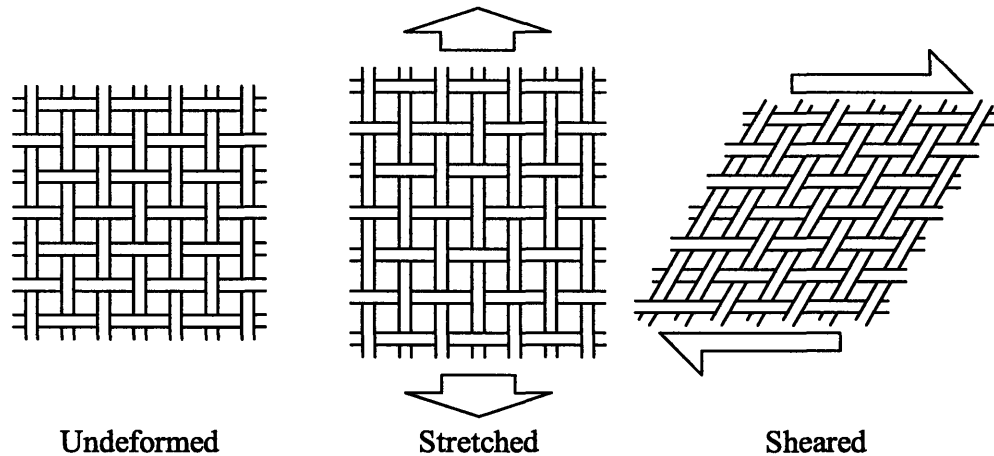

Figure 2-3: Weave Deformations

In the current skin-spar joint, the shear loading is largely taken by a bias cloth that is laid-up on the surface of the pi-shaped preform, as shown in Figure 2-2. This bias cloth contains the $\pm 45^\circ$ yarns, but is really just a piece of $0^\circ/90^\circ$ weave that has been turned 45° relative to the part; it is also produced on standard looms. These bias yarns do get stretched when shear is applied between the skin and spar, and so can effectively resist these forces. However, the pi-shaped preform and bias cloth are bound together by the resin only.

In practice, the problem with this solution is that the bias cloth delaminates from the preform. This may happen as a result of cracks propagating between the parts from the edges, normal stresses between the parts at the corner (for example), or errors in the lay-up procedure. Besides the functional problems, the manual labor involved in lay-up is expensive. The delamination problem can not be fixed by sewing the parts together, because the stitching process causes damage to the woven parts.

Weaving the bias threads among the $0^\circ/90^\circ$ threads would solve the delamination problem, and remove the necessity of some manual labor. Until now, it has been impossible to produce such a weave. The technologies that come closest to this task are 3D braiding and multiaxial weaving [3], but these technologies are inadequate: 3D braiding cannot include fill yarns, which are important for strength. Multiaxial weaving can only produce flat fabrics. These particular technologies will be discussed further in Chapter 4.

Chapter 3

Braids

A braid can be loosely defined as any collection of generally continuous, sometimes intertwined strings that do not loop back along the braid direction. This encompasses what one normally thinks of as braids, as well weaves and bias weaves. Textiles that are not braids include knits and felts.

This chapter begins with a brief overview of the theory of braids developed by Artin. It will provide a more solid notion of what a braid is. It also suggests other conclusions: 3D braids are not fundamentally different from flat braids, passable thread packages are necessary, what a complete braid description is, and what is necessary for a machine to braid every possible braid. It will also demonstrate that the important aspect of thread movement as it relates to braiding is simply whether a given thread moves over or under each thread that it passes.

A few specialized braids are discussed at the end of the chapter: $0^\circ/90^\circ$ subweaves and bias subweaves. Bias subweaves can be joined together (“compounded”) and embedded in a $0^\circ/90^\circ$ subweave to create useful bias weaves (such as one to connect wing skins to spars). Chapter 6 describes how this is done on the proposed machine.

3.1 Artin’s Theory of Braids

The study of braids was well developed as a mathematical subject [21] by Emil Artin around 1925. Braid theory, like any good mathematical theory, is useful for many things beyond the

physical objects on which the model was originally based. None of the those other uses are relevant here. The important thing for this paper is that these mathematical braids have the basic properties of a physical braid.

The mathematical rigor of Artin's construction is not necessary here, but a basic description of the subject will be helpful. His theory organizes a number of physically obvious properties of braids into a coherent whole which makes concrete the braid concept that we are talking about, points to some important requirements of braiding machines, and suggests some alternative ways of thinking of braids. It also provides a theoretical structure that can be used as a starting point for further study of braiding machines.

3.1.1 Definition of a Braid

Artin's model of a braid consists of a set of strings running from a row of points on one plane to a row of points in a parallel plane, as in Figure 3-1. These strings must satisfy the restriction that they do not loop back in the x direction (in the Figure), so every string intersects each y - z cross-section exactly once. Let this particular example braid be called β_{ex} . The x axis will sometimes be referred to as weave or braiding direction. Planes perpendicular to it will be called cross-sectional planes, or braid cross-sections.

3.1.2 Equivalence

Two braids are considered equivalent if and only if the strings in one can be moved—without passing through each other, but possibly changing length—to be in the same position as the strings in the other. This is essentially a topological model; in the end, the exact geometry does not matter. Instead, the braid's identity depends only on how the strings are intertwined.

3.1.3 Braid Projections

In order to more easily represent any braid, one can project the strings along the z axis to produce a diagram such as in Figure 3-2. The string locations should be adjusted so that the strings cross at a finite number of points, with two strings at each crossing.

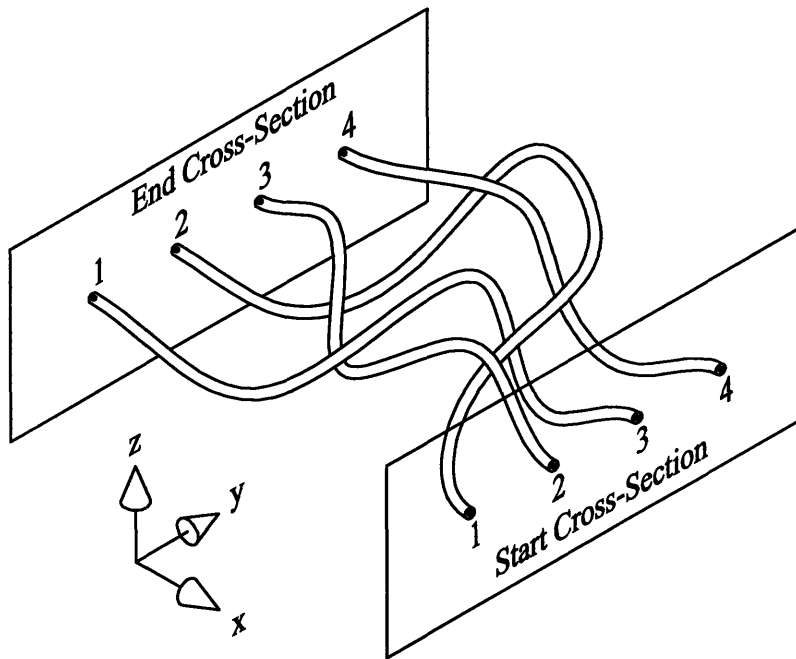

Figure 3-1: An Example Braid, β_{ex}

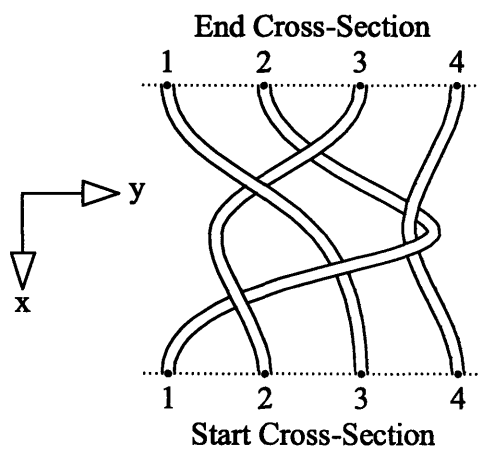

Figure 3-2: A Braid Projection of β_{ex}

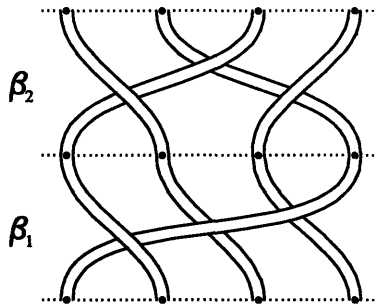

Figure 3-3: Braid Multiplication: $\beta_2\beta_1 = \beta_{ex}$

3.1.4 Description of a Braid

Artin defines a number of operations that describe certain braids based on other braids and fundamental operations. These concepts provide a language for talking about braids, and a basis for one way of thinking about them.

Multiplication

Suppose there are two braids, β_1 and β_2 , with the same number of strings. If the strings at the end cross-section of β_1 are connected to the strings at the start cross-section of β_2 , to produce a single braid, it can be written as $\beta_2\beta_1$. Figure 3-3 illustrates this. The reason this is written as multiplication will become apparent shortly. Obviously, this multiplication does not generally commute.

Identity

Denote the braid where all the strings do not twist at all (and therefore could be made to run parallel) as the identity $\mathbf{1}$. For any braid β , $\mathbf{1}\beta = \beta\mathbf{1} = \beta$.

Inverse

For every braid β , there is another braid, β^{-1} such that $\beta\beta^{-1} = \beta^{-1}\beta = \mathbf{1}$. In a physical sense, this braid simply undoes each of the twists in the original braid. The inverse of the β_{ex} from Figure 3-3, is shown in Figure 3-4. A braid projection of the inverse will appear like a mirror image of the original. In general, $(\beta_2\beta_1)^{-1} = \beta_1^{-1}\beta_2^{-1}$.

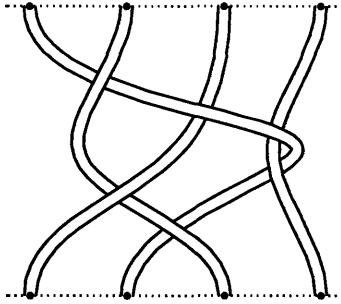

Figure 3-4: Inverse of β_{ex}

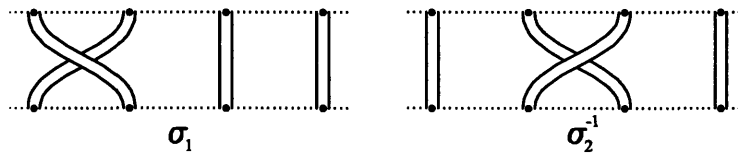

Figure 3-5: Some Elementary Braids

Elementary Braids

Let σ_n be the braid where the strings $n + 1$ and n switch places, with the string that was originally at $n + 1$ moving over¹ the one originally at n . All other strings run parallel without twist. Of course, the inverse, σ_n^{-1} , also exists. Figure 3-5 shows some examples.

Braid Words

One can take any braid, such as the one in Figure 3-2, and adjust the strings (of course, not moving through each other) so that the braid is partitioned into a number of elementary braids. The braid can therefore be described by the multiplication of elementary braids. For example, the braid $\beta_{ex} = \sigma_2^{-1}\sigma_1\sigma_3^{-2}\sigma_2^{-1}\sigma_1$, as shown in Figure 3-6. This decomposition is the braid word.

A given braid may have multiple representative braid words. Any valid braid word can

¹This is an arbitrary choice, and may be opposite in some books.

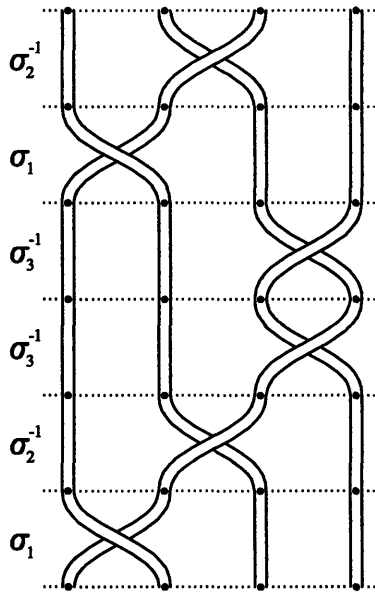

Figure 3-6: Braid Word: $\beta_{ex} = \sigma_2^{-1}\sigma_1\sigma_3^{-2}\sigma_2^{-1}\sigma_1$

be transformed into any other equivalent braid word using the identities [31]

$$\begin{aligned} \sigma_i\sigma_j &= \sigma_j\sigma_i && \text{for } |i - j| \geq 2 \\ \sigma_i\sigma_{i+1}\sigma_i &= \sigma_{i+1}\sigma_i\sigma_{i+1} && \text{for all } i \end{aligned}$$

Both of these have straightforward geometric interpretations.

3.2 Basic Conclusions about Braids

3.2.1 3D Braids vs. Flat Braids

One might complain about the fact that the strings all begin and end in a row, particularly if one wishes to study braids that are not flat. In fact, it does not matter.

Consider the braid shown in Figure 3-7. In this case, the strings all begin and end on a square. If the string ends were moved along some non-intersecting paths so that the strings did end on a line, the braid could then be studied using Artin's theory (this is schematically shown in the illustration). If two braids are not equivalent when the strings end on the square,

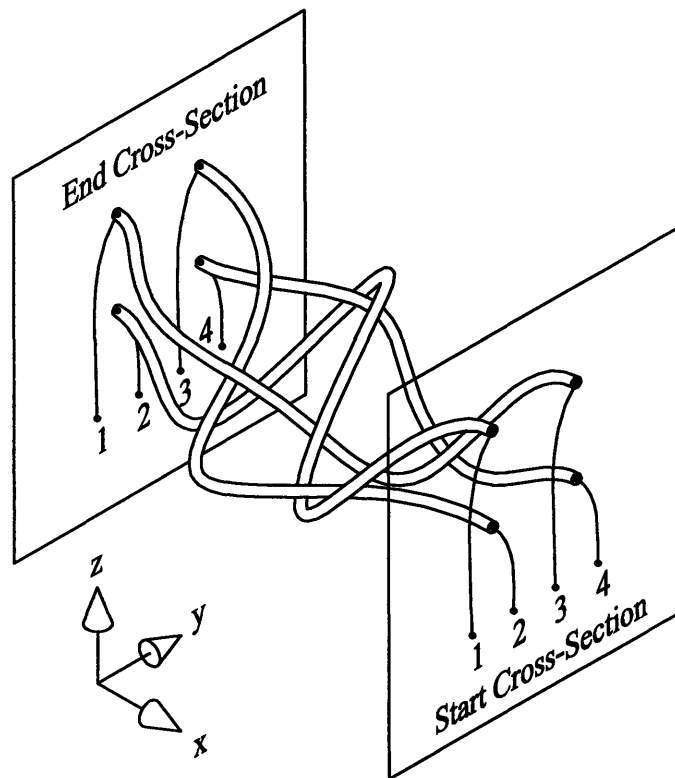

Figure 3-7: A Three Dimensional Braid, Mapped to β_{ex}

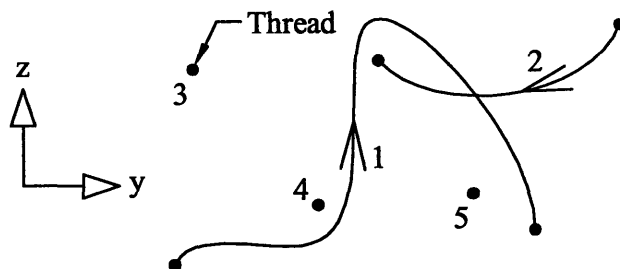

Figure 3-8: Strings Moving in the Braid Cross-Section

moving the strings to the line will still produce two non-equivalent braids. Conversely, if the two braids are equivalent when the strings end on the square, they will still be equivalent when the strings are moved to the lines.

Thus, one can choose a one-to-one mapping between braids with nonstandard endpoints and braids with standard endpoints. With the mapping indicated in Figure 3-7, the braid can be seen to map to β_{ex} . In other words, there is no fundamental difference between “three dimensional” braids and “flat” braids. Similar mappings can be performed when the starting and ending points fall on some other surface besides a plane.

3.2.2 Twist

Informally, what Artin’s description of braids is really doing is codifying a criteria for when threads have crossed each other, and the sense in which this crossing occurs. This (and the discussion that follows) is sort of an interpretation of Artin’s theory, a way of thinking about it that may or may not be useful to other people, and is not so carefully developed. In other words, take it lightly.

Imagine watching, as the braid progresses, the movement of the threads in the braid cross-section, as depicted in Figure 3-8. Threads 1 and 2 are moving. Twist between two threads can be defined as the angle a vector between the two threads rotates through as the braid progresses (as seen from the $+x$ axis). It is positive when the vector rotates in the counterclockwise direction and negative when it rotates in a clockwise direction. In some cases, threads will cause more than one complete rotation.

In Figure 3-8, thread 1 undergoes positive twist with threads 3 and 4, and negative twist

with thread 5. The twist between threads 1 and 2 is not clearly shown. Their trajectories as a function of time would have to be better defined in order to determine it. If one thread completes its move before the other starts moving, the twist sense would depend on which moved first. This ambiguity is resolved by considering a sufficiently small portion of the braid. Notice that when threads are moved between stationary points, twist can only come in a discrete set of values.

The topology of the braid is completely described by how, as a function of time, each string twists with every other string. However, this also contains extra information, since there are twisting movements that do not actually change the topology of the braid. A good braid description should better distill this information.

This can be done by partitioning thread configurations on the braiding plane into equivalence classes. Thread configurations should be considered equivalent only if moving among the configurations of the same equivalence class does not change the braid's topology.² When the thread configuration transitions between equivalence classes, one should describe only as much twist information as is necessary to distinguish that movement from the other non-equivalent movements.³ By this method, a description based on continuous twist variation can be replaced with a discrete description, where twist sense is only indicated when threads pass each other.

Artin's description considers the thread configurations to be equivalent when they preserve the left-right order of threads. If this ordering changes, the different ways of changing are distinguished by the sign of the twist between the two threads that are breaking the order. That is, a single $\sigma_n^{\pm 1}$.

Other thread configuration equivalence classes could be chosen, and in that case, different information may be needed to distinguish ways of transitioning between equivalence classes. Some of these choices may better capture qualities that are hidden in a description that seems to favor flat braids. Since we mainly need Artin's conception of braids to provide a

²The fixed-endpoint notion of braids has been sneakily discarded here, but no replacement criteria has been established for which thread-end movements are allowed when checking braid equivalence. This would have to be rectified. As the very least, staying in the same thread configuration equivalence class should prevent the addition of unbounded amounts twist between the fibers.

³Twist need not be taken as the important information, either. Any other distinguishing information would work. Twist just seems like the information most directly relevant to braids.

solid conceptual anchor—not a system that will be used in detail—no alternative will be further developed here.

3.2.3 Complete Braid Descriptions

The braid word is a complete description of a braid. Any other description of a braid is complete if and only if it can be transformed into a braid word or any other complete description. Therefore, a braid projection, such Figure 3-2, is another complete braid description. A sufficiently detailed description of the operation of a particular braiding machine would also be a complete braid description.

3.2.4 Sub-Braids

Define a sub-braid as what is left when certain threads in the original braid have been removed. If two braids are equivalent, then they can be broken up into equivalent sub-braids. This can be a useful way of comparing braids. The converse is not true: $\sigma_1\sigma_2$ and $\sigma_1^{-1}\sigma_2^2\sigma_1^2\sigma_2^{-1}$ have equivalent smaller sub-braids, but they are not equivalent.

3.2.5 Necessity of Passable Thread Packages

Suppose one has a set of parallel threads, running from an unfinished weave through some machinery to a creel. Suppose the threads initially form an identity braid (if this is not the case a similar argument will still hold). The thread ends located in the unfinished weave and the thread ends in the creel do not move, so if a braid is produced between the unfinished weave and the machinery, then the inverse braid must be produced between the machinery and the creel. At some point this inverse braid will become problematic for thread feeding, so the machinery cannot continuously braid these threads. It may be possible to produce finite-length parts this way, but most likely they would be too short to be useful.

Similarly, suppose the threads run from the unfinished weave to spools held by parts of the machinery. If the machine structure from the spools to ground is movable but not structurally detachable, then continuous braiding cannot occur. In this case the “strings” consisting of the thread between the spool and the unfinished weave, and the structure

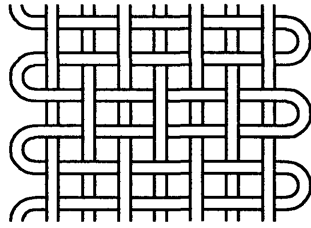

Figure 3-9: An Identity-Braid Textile

between the spool and ground, also form an identity braid (most likely curved weave cross-sectional planes are needed to formally show this). Creating a braid in the thread part of the “string” must produce the inverse braid in the structure part of the “string”. The machine cannot braid itself indefinitely.

In summary, any braiding machine that produces a nonidentity braid must necessarily have thread ends which can pass from one structural loop to another. This is the passable thread package. In standard weaving, the shuttle serves this function. The thread end contained in the shuttle is released from the structure on one side of the weave, and picked-up by the structure on the other side, and vice-versa.

3.2.6 Identity-Braid Textiles

It should be pointed out that there are useful identity-braid textiles. The weave shown in Figure 3-9 is an example. It would be possible to unravel without moving the ends, but if it is wide and later cut up into pieces, this is not really an issue. These sorts of weaves are typically produced by needle looms.

In a mechanical sense, the reason this textile can be produced is that the warp threads can be formed into a shed that allows a fill loop to be poked through. In bias weaving, by contrast, any line that separates completed fabric from unwoven fabric will necessarily have at least three of the four sets of yarns (0° , 90° , $+45^\circ$, -45°) crossing it, and this will make shed-forming difficult. Forming the shed, not passing the shuttle or loop, is really the crux of the problem. In other words, it does not seem like identity braids offer any particular advantage in bias weaving.

3.2.7 Number of Required Passable Thread Packages

It can be seen that for any sub-braid, if an identity braid is not formed, at least one of the threads in that sub-braid must end in a passable thread package. Of course, there are different ways that passable thread packages may be allocated. For instance, in normal $0^\circ/90^\circ$ weaving, the fill could be passable, or all of the warp threads could be passable.

Unless the bias weave is very contrived, any bias thread may braid with any other bias thread (or warp thread). So there must be one passable thread package per bias thread, plus one for the fill. Figure 4-2 shows a braid that is contrived in such a way—bias and warp together form the identity braid—to get around this requirement.

It should be pointed out that the number of passable thread packages is not necessarily equal to the number of independent structural pieces. The carousel-type multiaxial weaving machine in Section 4.2 clearly shows this. In this case, there are two sets of threads, each of which don't braid amongst themselves.

3.2.8 Requirement for a General Braiding Machine

The ability to produce an arbitrary string of elementary braids, $\sigma_n^{\pm 1}$, is a necessary and sufficient condition for general braiding ability. It is necessary because one might be required to produce any string of elementary braids. It is sufficient because every braid can be broken down into these elementary parts.

3.3 Biaxial Weaves

Since it is difficult to analyze arbitrary braids, only specialized braids will be investigated further. The simplest of these is the biaxial weave. These braids have two sets of threads that, taken separately, are identity braids.⁴ Biaxial weaves have also been well studied, on a more practical level, from several hundred years of textile production [30].

⁴This is a property, not a definition. Chain-link fences are not biaxial weaves.

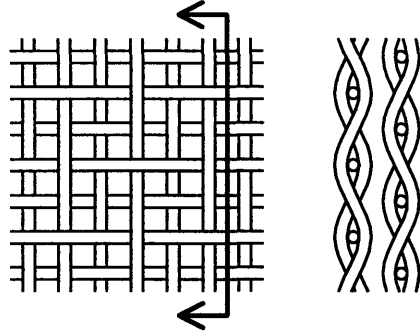

Figure 3-10: A Weave Projection and Side Cross-Section

3.3.1 $0^\circ/90^\circ$ Weaves

A typical $0^\circ/90^\circ$ weave is a biaxial weave. The warp fibers, if looked at separately, form an identity braid. The fill fiber, on its own, just zig-zags back and forth, again forming an identity braid. As with any other braid, the threads can be moved to form a proper braid projection. An example weave projection is shown in Figure 3-10. As is the case with other braid projections, this does not imply the weave is so flat in reality. The weave shown in Figure 3-10 is two plain weaves on top of each other, as shown in the cross-section. This cross-section shows geometric information more than topological information, but may be a useful tool. In general, it takes some work to deduce the likely final geometric configuration from over-under topological information [22, 28]. This is a specific example of a more general problem with braids.

It must be admitted that the edges of the weave are being ignored in Figure 3-10. While the edges are important for getting a complete description of the braid, often one may not care (for example) which way the fill loops around, or even whether the fill is composed of one fiber, or many cut fibers (as is produced by rapier looms where the fill is cut at every pass).

3.3.2 Specialized Braid Description for $0^\circ/90^\circ$ Weaves

These braids contain less information than general braids: Every σ_n in the braid must be followed by a σ_{n-1} , σ_{n-1}^{-1} , σ_{n+1} , or σ_{n+1}^{-1} . This means that a more succinct braid description

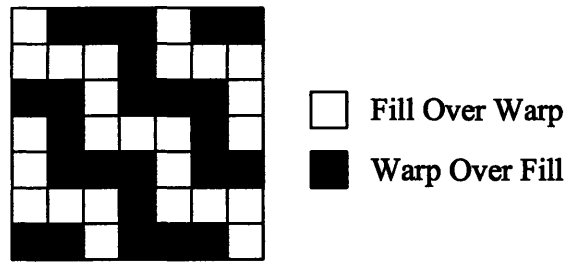

Figure 3-11: Binary Representation of the Weave

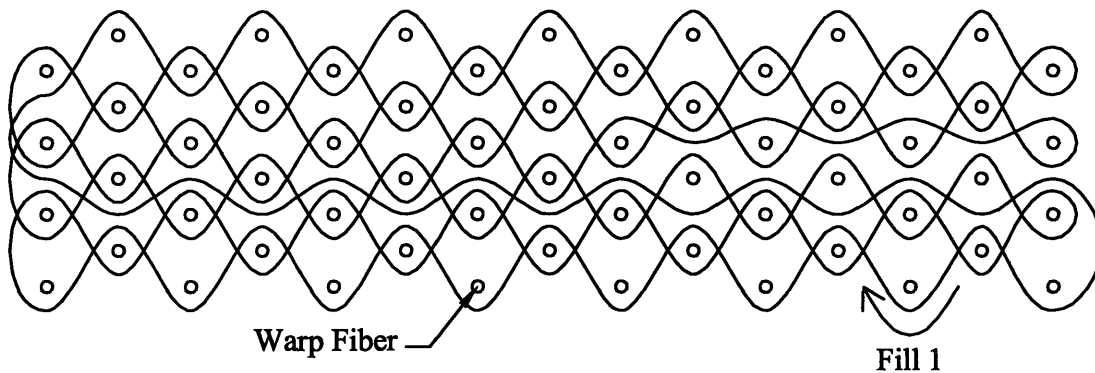

Figure 3-12: Fill Representation of the Weave

may be used.

The crossings can be represented in a binary fashion—warp over weft or weft over warp—as shown in the weave diagram, Figure 3-11. This is the way weave information is presented for programming Jacquard machines, even some electronic ones such as those made by Stäubli.

One could also represent the path of the fill fibers relative to (straight) warp fibers in the weave cross-section, as shown in Figure 3-12. This shows how threads move in the braid cross-section, as in Figure 3-8. This description implicitly should be seen in relation to standard weaving machines (heddles, shuttle, etc.).

With both this and the binary representation, a σ -type description could be extracted with some work and possibly minor additional information. Therefore, it is a complete braid description, or close to it.

3.3.3 Biaxial Subweaves

A biaxial subweave is a sub-braid that happens to be a biaxial weave. As with the other biaxial weaves, one often ignore the edges. That is, the subweave is a patch cut out of the braid, with some strings dissolved.

By removing two of the four sets of fibers (0° , 90° , $+45^\circ$, -45°) in a bias weave, a biaxial subweave is produced. Since there are four sets of fibers, there are a total of six possible biaxial subweaves. These can each be shown in separate weave projections. Figure 3-13 shows the six biaxial subweaves of the bias weave shown in Figure 1-1. As with the previous weaves, they contain over-under information.

These representations are useful in evaluating braiding machine designs for two reasons: Producing all the subweaves of a given braid is a necessary condition to produce that braid (but not sufficient; see Section 6.6). Subweaves also provide convenient building blocks for designing more complicated braids, as described in the next section.

3.4 Compound Braids

Define a compound braid as braid that is produced by simultaneously braiding two or more subweaves—braiding them in parallel, loosely speaking. These braids may or may not interact with each other. Interactions may include crossings, braiding, and threads feeding from one subweave to another.

This way of thinking of braids is a tool that will be used to break the task of analyzing braids into smaller parts. Specifically, one can understand the subweaves separately, and then study the ways in which they can be joined together. This is demonstrated, with regard to the proposed bias-weaving machine, in Chapter 6.

Furthermore, the braids that we most want to produce have a particular compound braid structure: Several parallel, crossing, and turning $\pm 45^\circ$ biaxial subweaves—bias layers—are compounded together, as shown in Figure 3-14. The threads may lead from one subweave to the next. Then, this braid is compounded with a fairly general $0^\circ/90^\circ$ biaxial subweave, by embedding the former inside the latter. The machine proposed in Chapter 5 is well adapted to efficiently produce this particular weave structure.

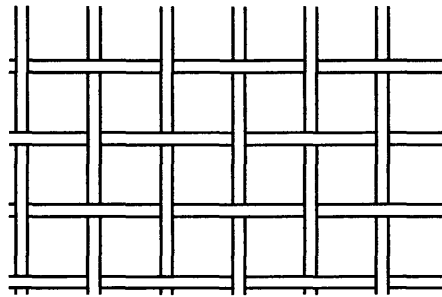

0 vs. 90

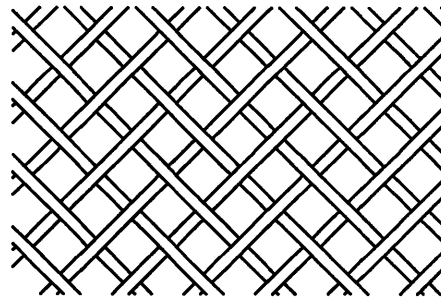

+45 vs. -45

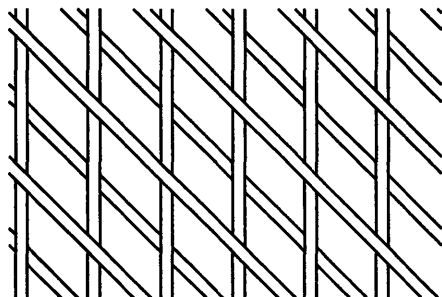

0 vs. +45

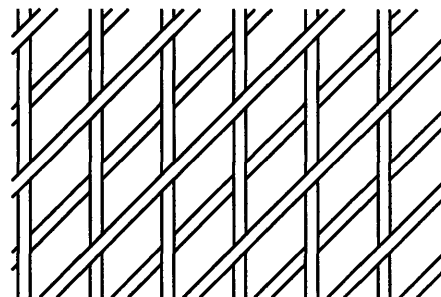

0 vs. -45

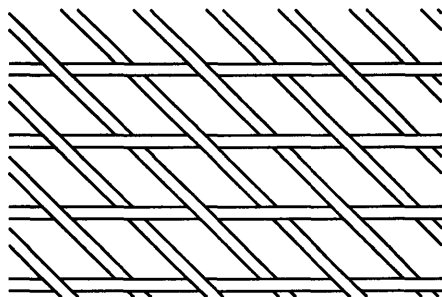

90 vs. +45

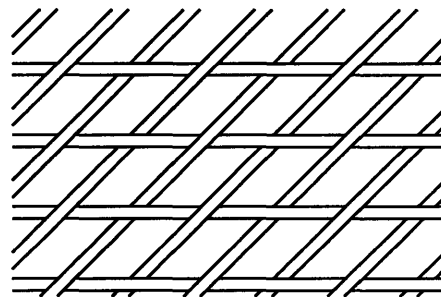

90 vs. -45

Figure 3-13: Bias Subweave Projections

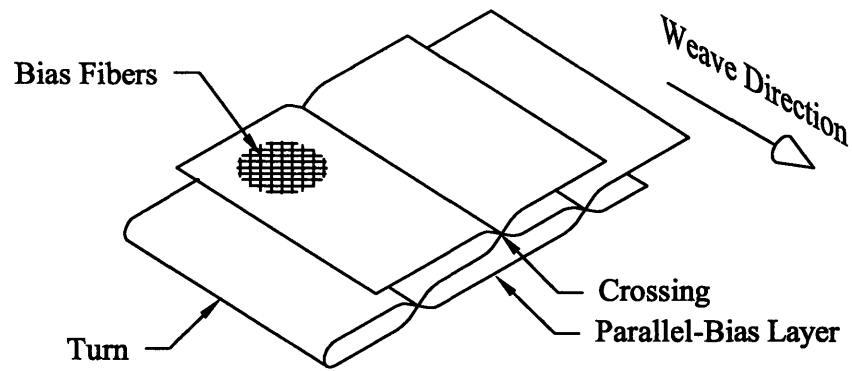

Figure 3-14: Example Compound Bias Weave

3.5 Braid Qualities, Besides Topology

The notion of a compound braid relates more to the geometric relationship between basic braids than the topological relationship between fibers. It is a braid description that is topologically less precise, but better captures some important aspects of the braid. This makes it both useful and acceptable. Physical weaves often have parts that are “on top of” or “under” other parts, and this often implies all that is needed about how they intertwine. A similar situation occurs when describing biaxial weaves. Ignoring the edges in the projection means the description is incomplete, but the description still captures the most important information.

These important aspects of the braid are the qualities that one would most likely use to describe the braid, and also the qualities that one would likely choose when designing it. The intuitive notion of what makes two braids similar or not revolves around these kinds of qualities, which may not be evident from, or even dictated by, the topological description. Artin’s description of braids was intended for very different purposes.

Chapter 4

Braiding Machines

This chapter will discuss some existing types of braiding machinery. It is intended to provide at least some hints of the state of existing prior art, the trade-off between braid generality and other factors, various mechanical considerations, and some common features of all braiding machines.

4.1 Weaving Machines

Typical $0^\circ/90^\circ$ woven cloth is so useful that there is little motive even to think of it as a specialized braid. Quickly manufacturing this most-useful of braids is very important, even though the machines involved cannot manufacture other types of braids.

Weaving machines are prime examples of how specialization can be of benefit in braiding machine design. These machines work as fast as they do because of the use of heddles to form sheds through which a shuttle is passed. This in turn, is only possible because the warp threads all run parallel to each other. In other words, it is only possible because it is a special type of braid.

4.2 Multiaxial-Weaving Machines

The machines known as multiaxial-weaving machines can produce bias weaves with certain restrictions. For instance, bias fibers can only braid with themselves in very particular ways,

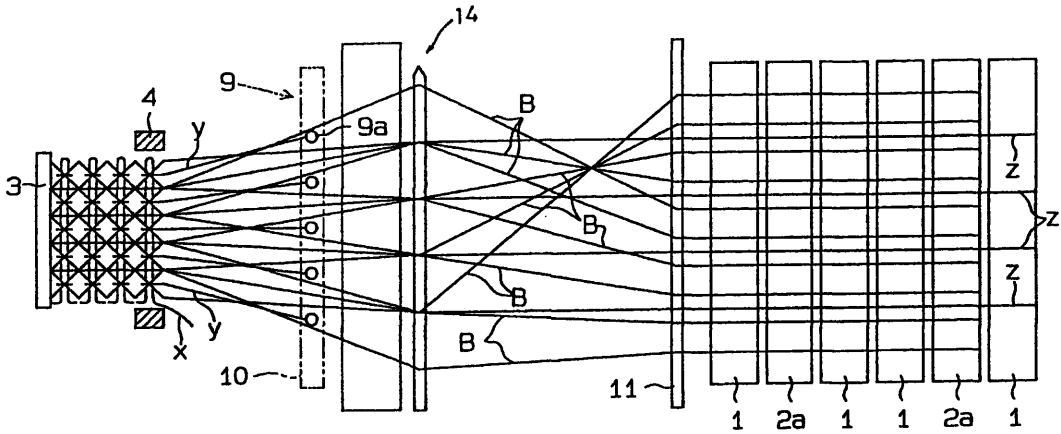

Figure 4-1: Identity-Braid Bias-Weaving, Top View. Drawing from [5]

and the warp fibers cannot cross the bias layers. Specific examples will better illustrate the restrictions, and how these topological restrictions arise from the machine configuration.

4.2.1 Identity-Braid Machines

Some multi-axial-weaving machines function on the principle that an identity braid does not necessarily have only parallel fibers. Rather, the fibers can constantly braid and unbraid.

Suppose that, as the weave progresses, one of the warp fibers zig-zags across the other warp fibers. The fibers still form an identity braid as long as the zig-zag fiber comes back to its original location and undoes, on the way back, each of the crossings it made on the way over. This is one way that a machine can create a single bias thread. Similarly, more warp fibers can move across the weave to form a full bias layer. It is up to the fill fiber, which is possibly in a passable thread package, to hold everything in place, and keep these identity braids from unravelling. This mode of operation is shown in Figure 4-1, from [5].

The warp/bias fibers are restricted in their motion because every twist must be undone later—and, for practical reasons of thread feeding, not too much later—in order to preserve the identity braid. This prevents, for example, bias layers from crossing each other in natural ways or forming bias tubes. It also severely restricts how warp fibers can cross the bias layers. Still, some interesting braids can be made in this fashion, as shown in Figure 4-2, from [5]. This weave uses a rapier; it is an identity braid, even including the fill.

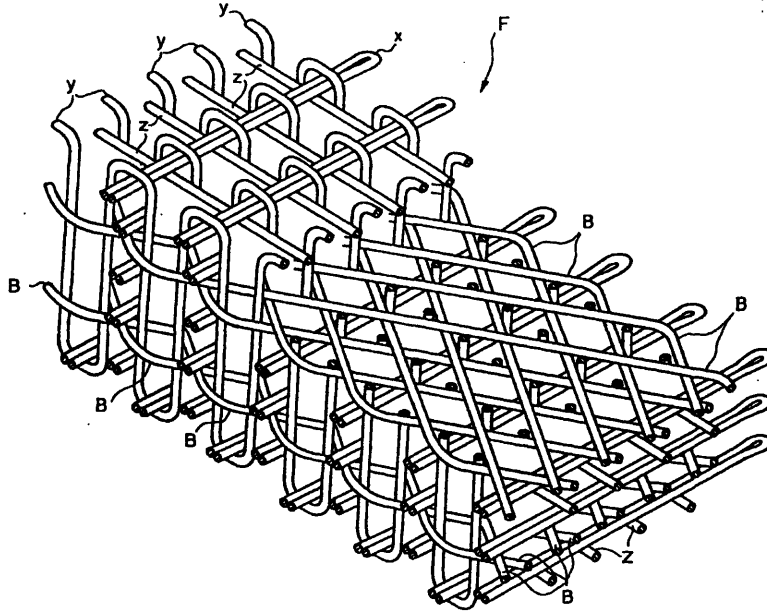

Figure 4-2: Identity-Braid Bias Weave. Drawing from [5]

4.2.2 Carousel-Type Machines

Other multiaxial-weaving machines have bias threads mounted on a large carousel that rotates relative to ground. Figures 4-3 and 4-4 show such a machine, from [27]. If the carousel is moving counterclockwise (as seen from the x -direction), the bias threads move left across the top of the weave, and right across the bottom. Warp threads could be introduced above, below, and in the middle of the carousel. Again, as with the identity braid machines, it is up to the fill yarn to hold everything together.

This structure imposes certain restrictions on the braid: The $+45^\circ$ and -45° bias layers cannot cross or braid with each other, and must be essentially flat. Each warp fiber must stay either above both bias layers, between them, or below them.

An Unusual Feature

The carousel is an object that is passed between structural connections, although these connections are being made and broken in a very continuous fashion. The bias threads are therefore feeding from passable thread packages, but unlike every other example of braiding

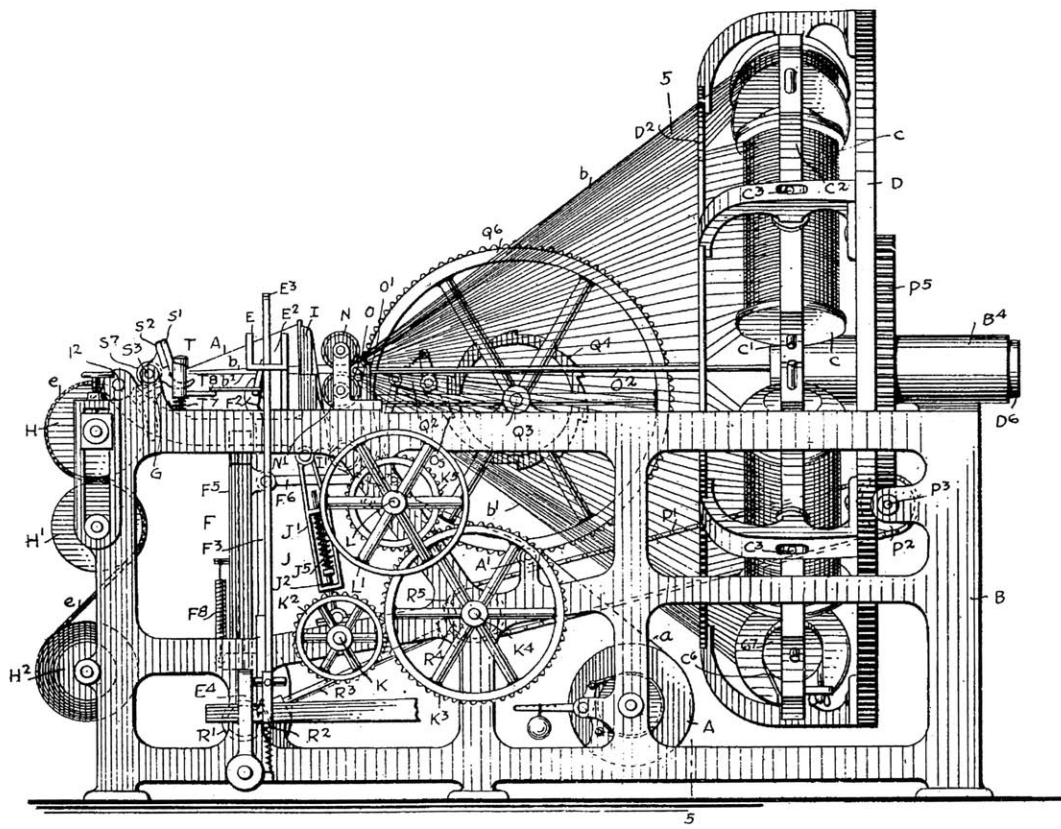

Figure 4-3: Carousel-Type Loom, Side View. Drawing from [27]

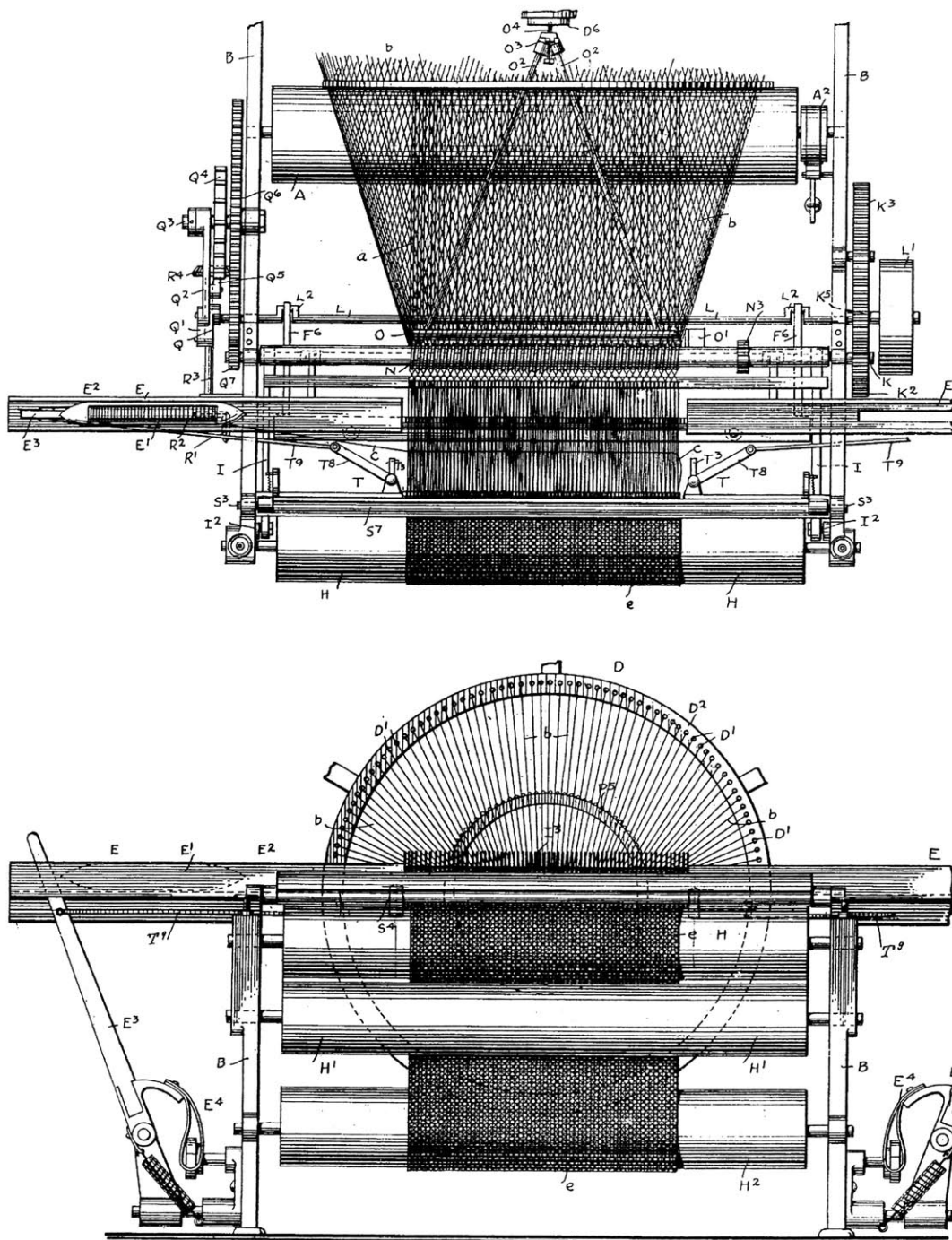

Figure 4-4: Carousel-Type Loom, Top and Front View. Drawing from [27]

machines in this thesis, these passable thread packages are rigidly mounted to each other. While this restricts the braid, it minimized the number of passing objects, and uses a type of passing that is particularly easy.

An Interesting Sidenote

Imagine a carousel-type triaxial weaving machine—no warp fibers—where the carousel is fixed to ground and the machine rotates around it. In this case the “bias” fibers, now grounded, all form an identity braid. A regular weaving machine could, in fact, make such a braid. Furthermore, a regular weaving machine could make the original triaxial weave, if only a twist was given to the final product. Or at least it could make a topologically equivalent braid. Geometrically, they would certainly not come out the same. This is a good illustration of how one does care about things beside geometry.

4.2.3 Fill and Beat-up Problems

One problem with these multiaxial-weaving machines is that the braids are too restricted for some purposes. Another problem lies in the mechanical details of passing the fill yarn. Practically, this is not a trivial task. Because the warp and bias threads lie so close together, the machine must, as in normal weaving, move the threads into a configuration that creates sufficient space for the fill yarn.

But unlike normal weaving, heddles cannot be used, since they would conflict with the moving bias threads. Inevitably, it seems some element must insert into the weave to push the fibers to the appropriate place while the fill thread is passed, and then withdraw before the bias yarns move. This is difficult to do repeatably. Beat-up similarly involves insertion, because the reed blades cannot remain located between both warp and bias threads. Figure 4-5 shows insertion of warp threads through the weave on an identity-braid machine [5], in order to allow fill insertion. Figure 4-6 shows the fill insertion and beat-up process on a carousel-type machine. There is an insertion into the weave for both operations: between Step 6 and 1 for fill, after Step 3 for beat-up. The bias threads would move after Step 6.

A more braider-like machine helps solve these problem, largely by creating more space.

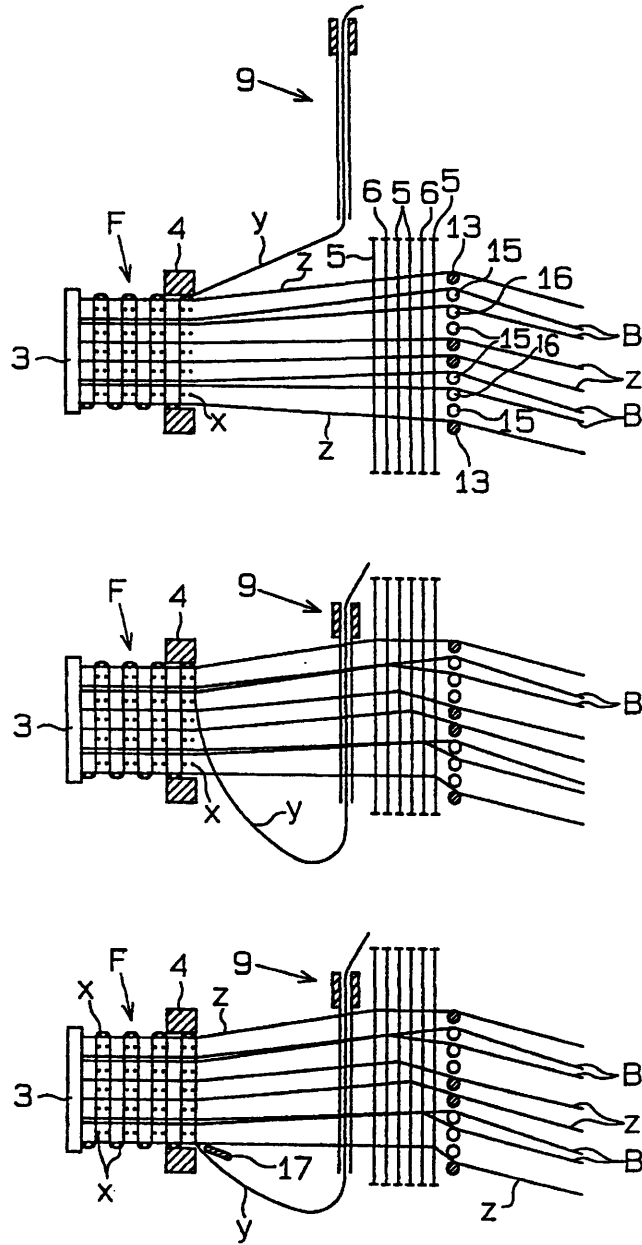

Figure 4-5: Filling on Identity-Braid Machine, Side View. Drawing from [5]

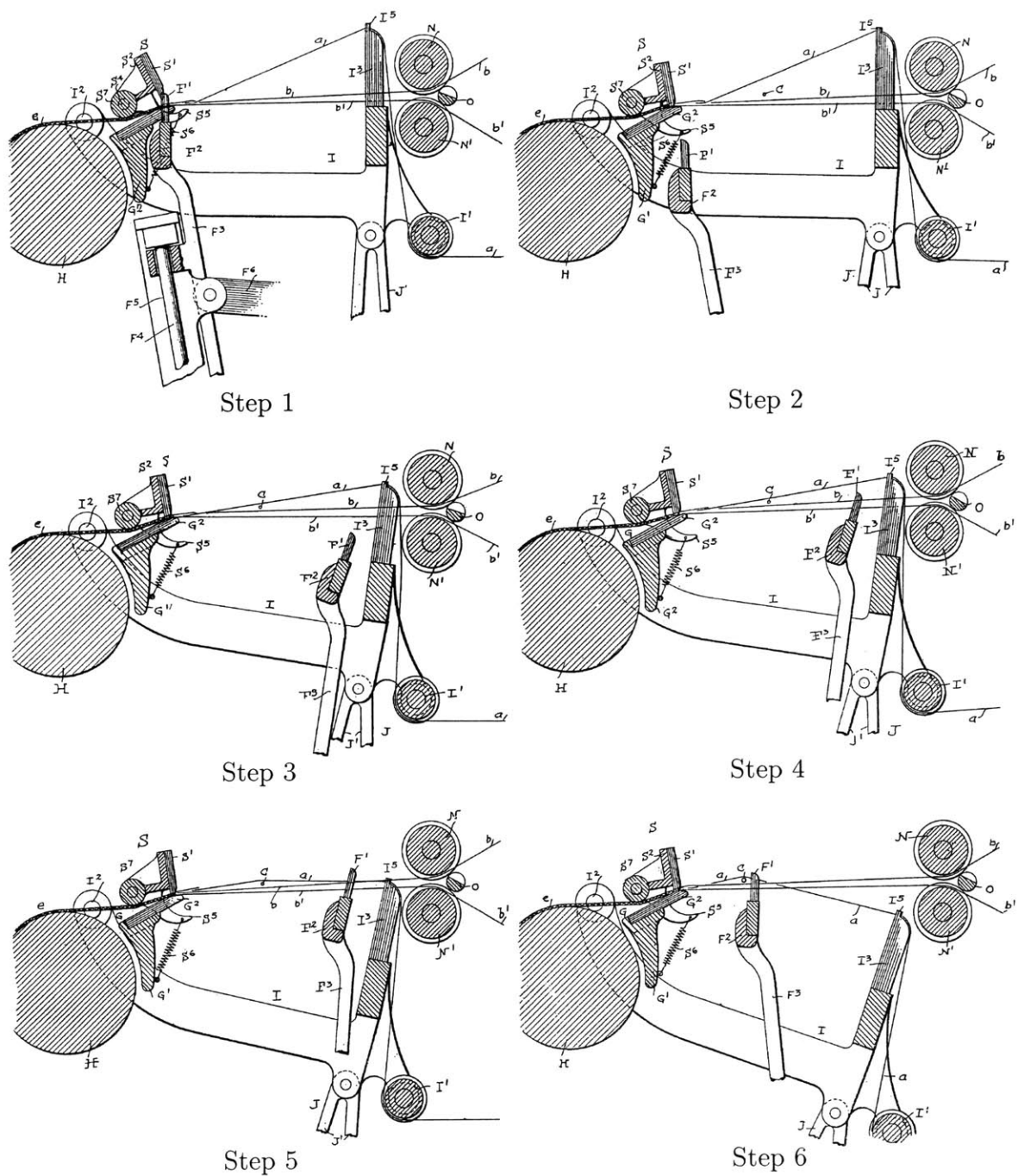

Figure 4-6: Filling and Beat-Up on Carousel-Type Machine. Drawing from [27]

But they sacrifice the ability to make very wide fabrics. The carousel-type machines, in particular, can make bias broadcloth.

4.3 Braiding Machines

A number of machines commonly known as braiding machines or 3D braiding machines have been proposed. They are mechanically different but conceptually similar to each other [19]. All of them use passable thread packages that are moved about the braid cross-section, often around stationary 0° threads. Figure 3-8 is fairly suggestive of this mode of operation. In practice, the thread packages are arranged in a regular pattern (often rectangular or circular), and only certain motions are allowed by the driving mechanisms. The machines differ in the methods that are used to move the thread packages. Some common types are described below, and will be further compared to the proposed braiding machine in Chapter 7.

4.3.1 Horngear Machines

The braiding machines which are typically used in production of braided rope, wires, etc. are the of the horngear type, because of their relative simplicity and speed. These use thread packages which are guided by intersecting tracks on the machine face and are propelled by a horngear mechanism behind the tracks. Stationary axial threads may pass through the machine face.

One common arrangement moves the threads in a maypole fashion around a circle. This is shown in Figure 4-7, from [10]. Appropriate tracks, possibly modular, can be used to fill other sorts of cross sections, such as I-beams [7].

4.3.2 The 3D-Solid Machine

The 3D-Solid machine is similar in its use of rotors for thread package propulsion, but avoids the inflexibility of hard tracks. The basis of this design is a grid of rotors that can each be individually turned. The passable thread packages fit in the spaces between the rotors. The thread packages are shaped so that turning an individual rotor will rotate the neighboring

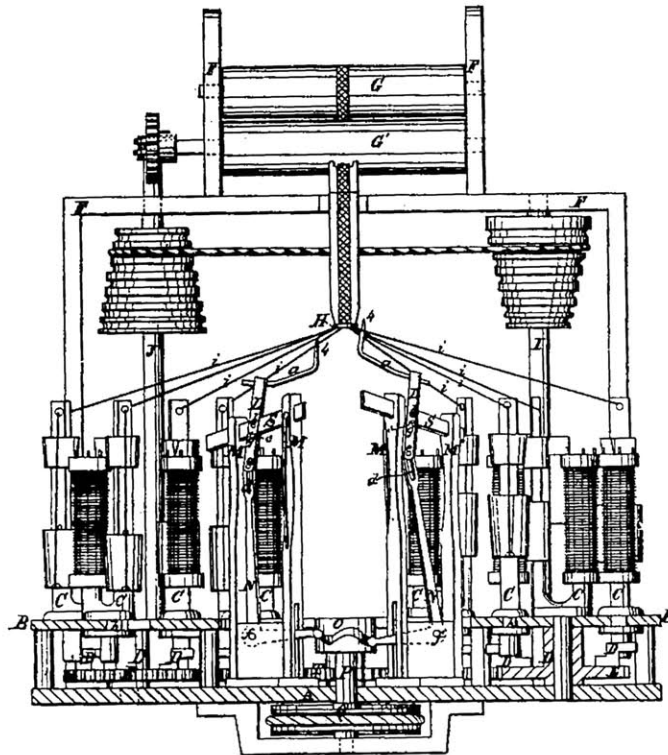
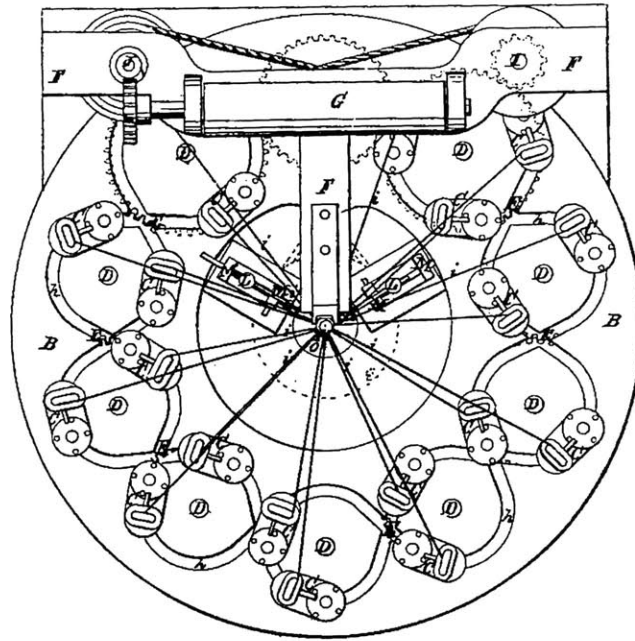

Figure 4-7: Horngear-Type Braiding Machine. Drawing from [10]

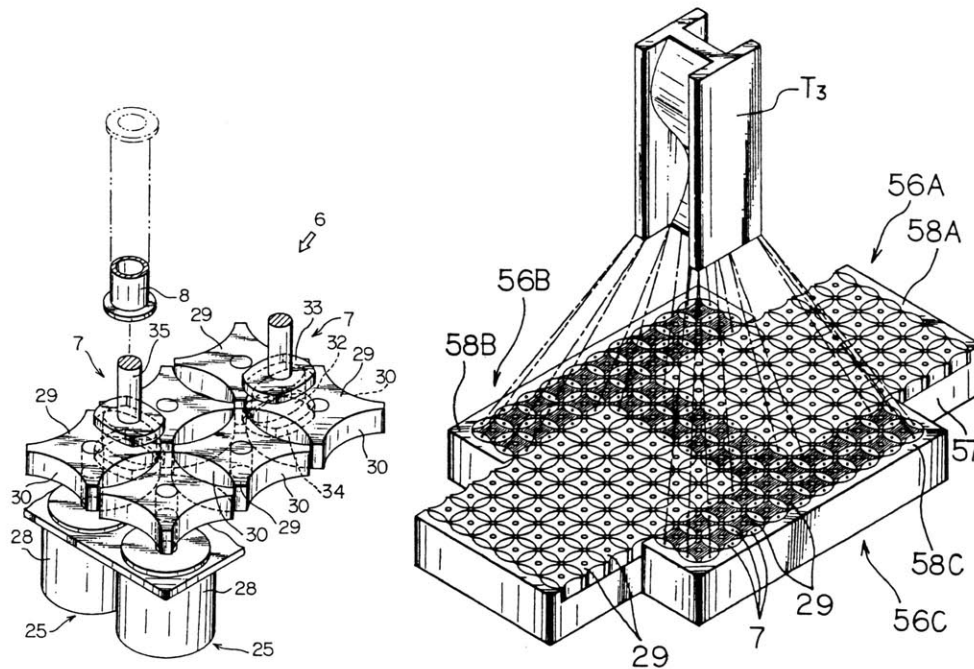

Figure 4-8: The 3D-Solid Braiding Machine. Drawing from [16]

four threads about the rotor center, exchanging their positions. One can see how a similar arrangement could accomplish, directly, the switching operations that form (or can be seen as) the basis of generic braiding. As with the horngear braiders, axial fibers may be run from the centers of the rotors, and the thread packages typically fill an area that mimics the part cross-section. Figure 4-8 illustrates this machine, from [16].

4.3.3 Cartesian Braiding Machines

Another common 3D braiding machine is the Cartesian braiding machine. Here, the movable thread packages are stacked together in grid form. Entire rows can be shifted horizontally, and entire columns shifted vertically. The operation of these machines somewhat resembles the operation of one of those puzzles that has sliding tiles which must be ordered (except there is more than one free space in this case). These braiding machines are also called four- or multi-step machines, depending on the particular shifting patterns used. Axial fibers are not easily introduced into this process, except by planning the shifting sequence so that certain thread packages do not move. Figure 4-9 shows the bed of a Cartesian braiding

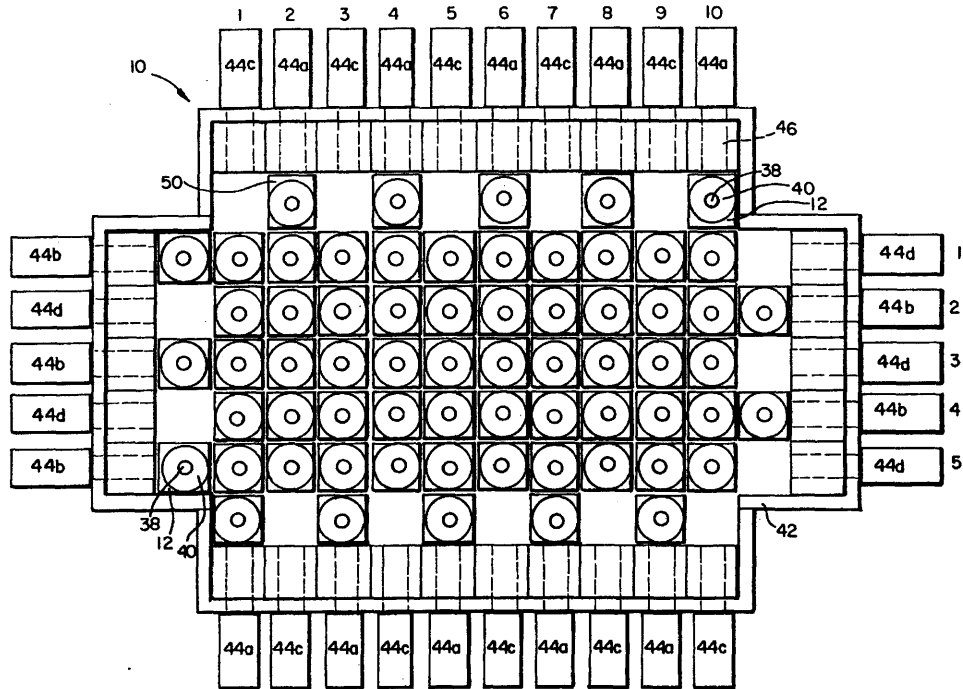

Figure 4-9: Cartesian Braiding Machine. Drawing from [17]

machine, from [17].

4.3.4 The Two-Step Braiding Machine

The “two step” braiding process [13] uses tracks arranged vertically and horizontally to form a square grid. Axial fibers run through the center of each square, and are laid out to form the cross-sectional shape of the part. The passable thread packages are initially placed at locations on the perimeter of the part’s footprint. Braiding proceeds by the repetition of two steps: each movable thread package is pushed horizontally to the opposite side of the part, then they are pushed vertically across the part. A two-step braiding machine is shown in Figure 4-10.

The parts produced by this method have a particular structure. The axial fibers are bound together by two sets of orthogonal fibers. These fibers run essentially perpendicular to the braid axis, instead of moving across diagonally. Or at least they would run perpendicular, if there were some mechanism for beat-up.

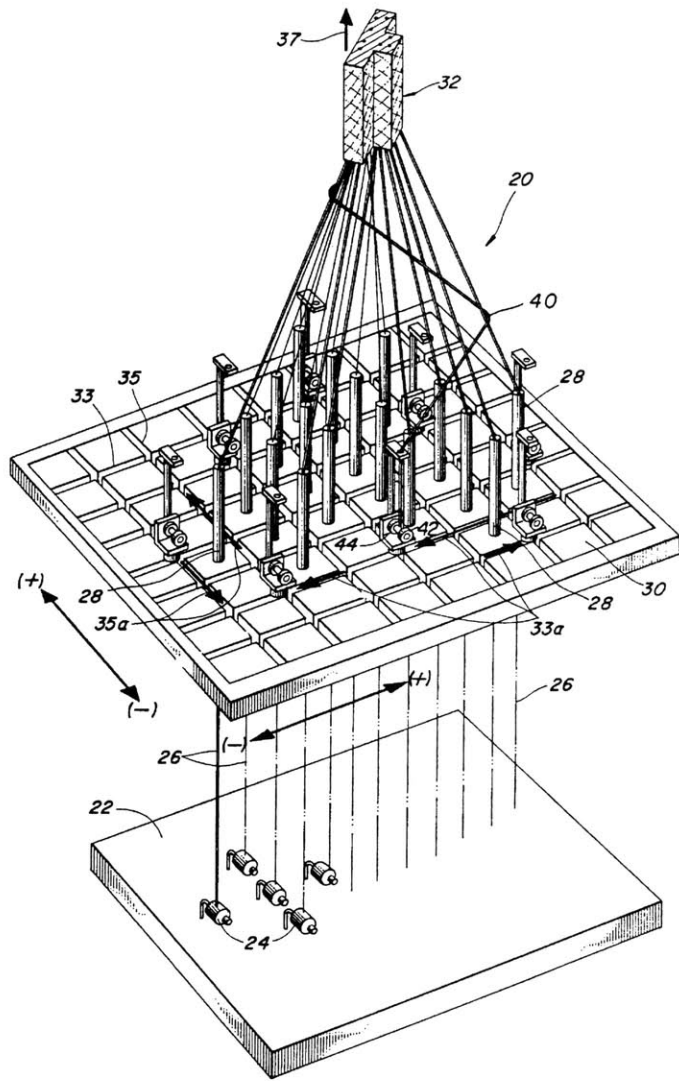

Figure 4-10: Two-Step Braiding Machine. Drawing from [13]

4.4 Beat-Up

With the exception of standard weaving machines, most braiding machines do not have any mechanism for beat-up. In order to ensure the proper geometric form of the braid, most braiding machines rely on balance of tensions, and the geometric similarity between the thread layout on the braiding machine and in the braid. This is often insufficient, though. In particular, friction imposes limits to the angle that threads make with the braiding axis.

Even though the purpose of beat-up is to ensure geometric regularity of the braid—the reed cannot affect the braid topology—it is hard to include a reed in braiding machines for basic topological reasons. Informally, if the reed blades are amongst the braiding yarns while braiding is occurring, the blades will be braided into the product as if they were (vertical) fill fibers.

Weaving machines dodge this problem because the the warp fibers do not braid with each other. A few other existing braiding machine designs solve this braiding-in problem by inserting the reed blades into the braid from the side, beating-up, and then removing them before braiding continues [6, 14]. Figure 4-11 shows this process, from [6]. By this method, the reed blades are never in the braiding area while braiding is occurring. Unfortunately, this approach may be slow, and risks catching threads as the braid is pierced.

4.5 A General Braiding-Machine Model

As far the topology of the manufactured braid is concerned, braiding machines (including weaving machines) usually can be described by

- A set of possible thread positions on a braiding surface. These positions are stationary, and can be empty or occupied by one thread.
- A set of possible machine movements. These are paths on the braiding surface that describe how threads move between thread locations. They may be available or not, depend on which thread locations are occupied.

Figure 3-8 is strongly suggestive of this model. The fact that the operation can be discretized is a consequence of the fact that braids can be broken up into discrete crossing operations.

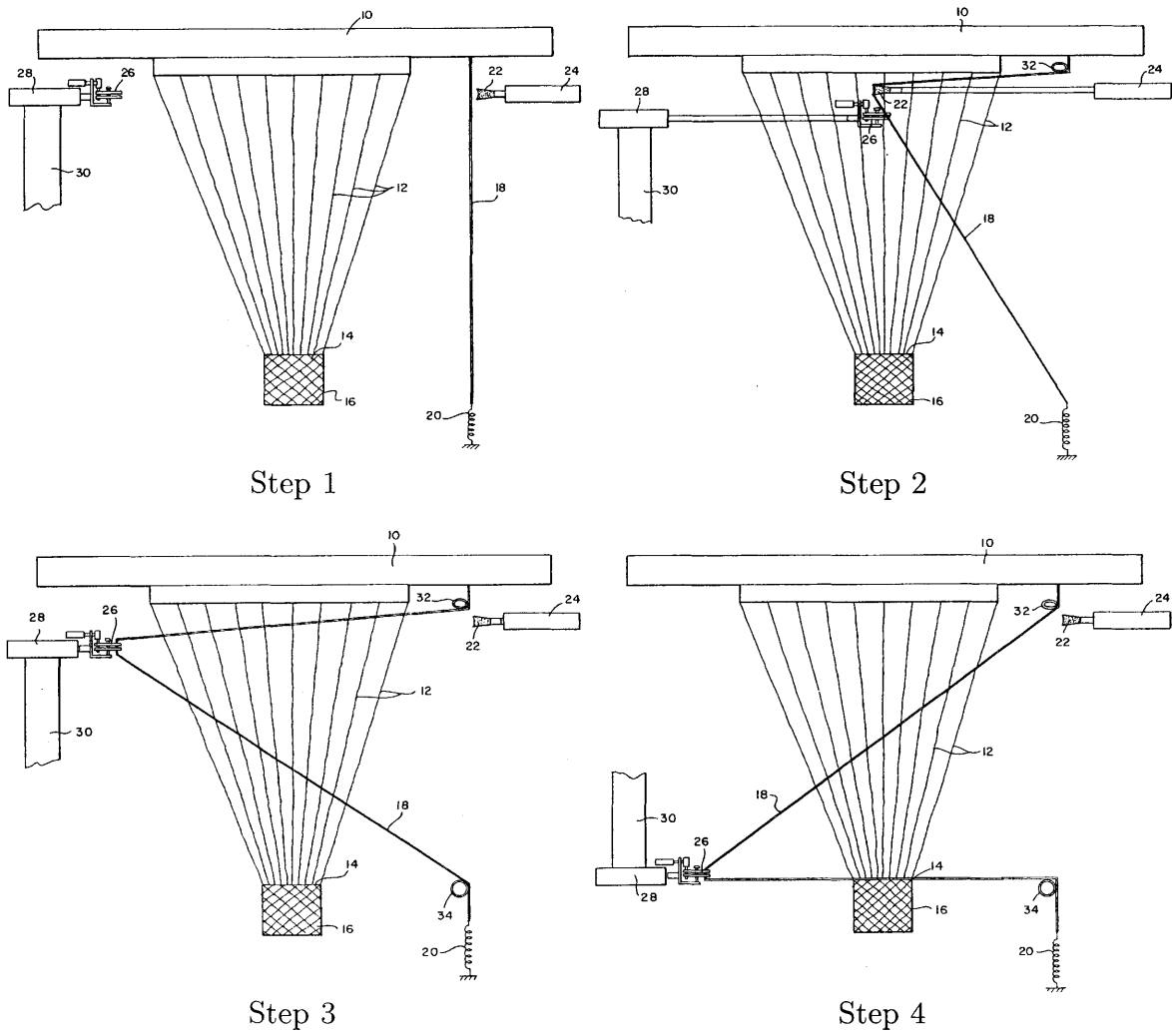

Figure 4-11: Insertion-Type Beat-Up Mechanism. Drawing from [6]

The model may not be unique, as there is some trade-off between the number of positions and the number of possible movements.

In weaving machines, the braiding plane is less obvious than in some other braiding machines, because the warp threads pass through it. The model for a weaving machine might include two thread positions—up and down—for each heddle and two positions—left and right—for the shuttle.

The production of a braid is described by

- The initial state of the machine: which thread locations are occupied.
- A series of chosen machine movements.

Each machine movement creates a small piece of braid (or equivalently, a series of σ -type operations) which depends on the state of the machine. That is, the same machine movement produces different braids (or σ -type operations) depending on whether or not a thread is in each location that gets passed by the moving thread.

4.5.1 Usefulness?

The model implicitly specifies all possible braids a machine can execute. A machine can produce any braid given by an initial setup and a series of allowed thread movements. Conversely, the machine can produce a given braid only if it can be broken down into a series of allowed operations starting from an allowed setup. Of course, there are other aspects of the machine that are not captured by this model, such as mechanical complexity and braiding speed. The implicit definition of braidability and the narrow topological focus mean that this model is only of limited usefulness.

Occasionally, such as in Section 6.6, when one has an idea of how many operations should be used, one can try to fit machine operations to a given braid. The bit of abstraction in this model is not really necessary to do this, but stripping away the other features of the machine may be helpful at times, particularly by highlighting the distinction between thread movements and thread moving mechanisms.

Some machines do not easily fit this model. Specifically, thread movements on a braiding surface are difficult to visualize on machines in which the middle of the thread is manipulated

by poking or forming loops. Carousel-type bias-weaving machines and sewing machines are examples these. Creative choice of braiding surface may be necessary.

4.5.2 An Alternative Model

For some machines, one can consider all the thread locations to be occupied, with some threads earmarked as imaginary. For instance, a movement that, in reality, moves one thread to an empty location can, in the model, be seen as switching two threads. One of these threads is marked as imaginary to represent the movement of the unoccupied thread location. These imaginary threads keep track of the machine state. The braid is given by a series of allowed machine operations—each of which adds to the braid word and does not depend on the state of the machine—and a specification of which threads are to be dissolved. The sub-braid that remains is the actual braid that is manufactured.

4.6 A Flat Braiding Machine

It may seem like the best braiding machine would have thread locations arranged in a line and include movements for switching any two adjacent pairs of threads, as in Artin's formulation of braids. After all, this allows each σ -crossing to be independently specified, rather than each operation creating a string of σ -crossings. While such an arrangement has all the flexibility one could want, it may lack efficiency.

It may be that the braid words for some types of desired braids have particular substrings that turn up often. If the braiding machine can make some of these braid pieces in one movement (or particularly fast), it may be able to make the braids more efficiently than a machine that pieces together the braid from elementary braids.

In fact, the idea for a flat, switching-based machine seems promising only because of the particular choice of braid description. Another choice may make other movements seem more fundamental.

Chapter 5

The Proposed Machine

This chapter presents the bias-weaving machine concept. Factors that suggest—not dictate—the form of the chosen design are presented in Section 5.1, followed by an explanation of the design itself, in Section 5.2.¹ The details of its operation related to the production of bias weaves are the real justification for the design. These are presented in Chapter 6.

5.1 Suggestions for Design

A starting point for the design of a bias-weaving machine is the decision to have continuous warp fibers. From a weave-design point of view, this makes sense, since we are primarily interested in producing long, narrow bias weaves.

5.1.1 Geometric Similarity with the Braid

Since the weave cannot be produced in a single step, there will always be a place that separates the finished weave from the unwoven fibers. In normal weaving, this is called the fell, a label that can be applied on bias weaves as well. The warp fibers necessarily cross the fell. At least two of the remaining sets of fibers must also cross it, since the fell can be only parallel to one set of the fibers. So there is at least one set of bias fibers that crosses the fell.

¹It may be useful to revisit Section 5.1 after reading Section 5.2, as the specifics of the concept may clarify what is meant.

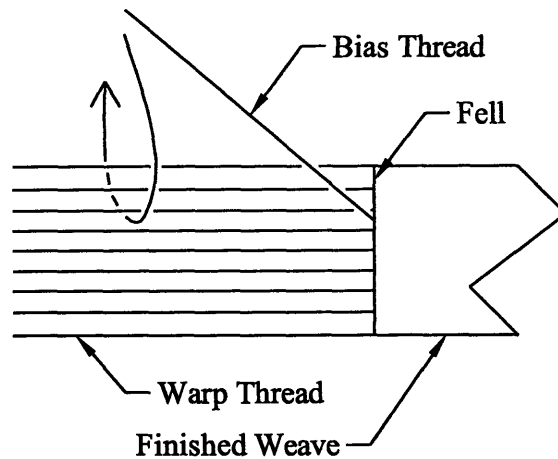

Figure 5-1: Bias End Outside the Weave, Advancing the Bias Fiber

From before, we know that if the bias fibers are to be generally braidable, they will need to be passable. We do not want to be subject to the identity-braid restriction.

Suppose we restrict our attention to one bias fiber that crosses the fell. As the weave progresses, that bias fiber would move along the fell, appearing in the gap between two warp fibers, then the neighboring gap, and so on. This is necessary, because otherwise that bias fiber would run parallel to the warp fibers in the weave, and would not be a bias fiber at all.

The end of this bias fiber (an end, or an end contained in a spool) could be located in various positions, but locating it in the same gap as where the fiber emerges from the fell has its advantages. The disadvantage of locating the end in another place is illustrated in Figure 5-1. Suppose this end must move along the fell in the upward direction (in the figure), while moving under the next fill thread. This would be a very common situation, in fact. In order to do this, the end must be brought through the motion shown: over the top of the weave, through the appropriate gap between warp fibers, and out of the weave on the bottom. If the thread end were already located in the gap between the warp fibers, the thread end could simply be moved directly under the next warp fiber.

A similar situation occurs when filling, as shown in Figure 5-2. Here the requirement is that the fill fiber passes under all the warp fibers, and over that bias fiber. Again, similar situations will be common in practice. In order to accomplish this, the fiber must pass through the motion shown: under the weave, up through the appropriate gap between warp

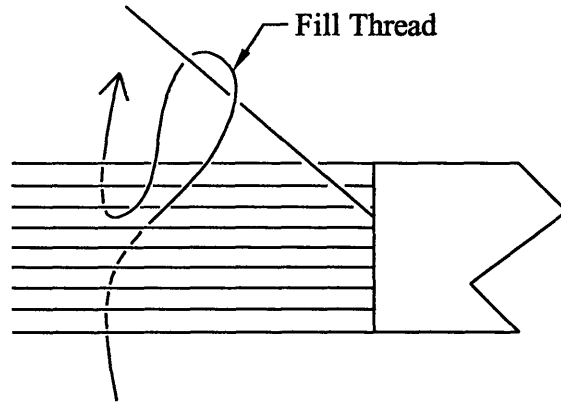

Figure 5-2: Bias End Outside the Weave, Filling

fibers, around the bias fiber, back through the gap, and under the weave again. If the bias fiber were located in the gap between the warp threads, the fill could be passed straight across.

In both the bias-passing and filling cases, keeping the bias thread end between the warp fibers allows for smaller movements as compared to keeping it to the side. This suggests that the bias-weaving machine should be constructed in this way. None of this means that it would be impossible to design a bias-weaving machine another way, but it suggests that it may not be the easiest way, since there is a lot more thread motion than necessary.

It raises the question of just how the bias package will fit between the warp threads. There are two solutions to that: make the unwoven fibers flare out to accommodate a reasonably sized package, or simply make the bias package very small. This decision will yield two radically differently appearing machines. We decided to use the former approach.

The argument above can actually be made slightly more generally, with yarns generally instead of just warp fibers: If the locations of yarns on the braiding machine reflect their actual positions in the braid, the amount of movement required to many particular sets of crossing is minimized. This is a theme that can be seen in many of the existing braiding machines discussed in Chapter 4, and will be revisited in Chapter 7.

5.1.2 Specialized Thread Movements for Specialized Threads

This machine is designed to for producing particular braids—bias weaves—that have particular characteristics. These characteristics can be exploited to simplify the machine. In doing so, some braids become difficult to braid, and others become impossible, but bias weaves become much more practical. This sort of specialization is, of course, a common theme in all sorts of machines (and many non-machines, too).

Warp Fibers

All of the bias weaves that we wish to make have a large identity sub-braid, consisting of all the warp fibers. That is, these fibers do not braid with each other, but do make up a large proportion of the braid. How should these fibers be treated?

In traditional braiding machines, threads are either stationary in on the braiding plane (axial fibers running though holes) or movable by passable thread packages (the braiding spools). Threads belonging to an identity sub-braid could be arranged as axial fibers though holes in the braiding plane. The braid would be made by having the other fibers move around these stationary axial fibers in the appropriate fashion. Alternatively, the threads belonging to an identity sub-braid could be arranged as braiding spools that do not braid about each other (but do braid about the other threads). This could potentially simplify the paths that the other spools need to follow, but comes with the penalty of the additional complexity of more passable thread packages.

The proposed machine instead takes advantage the way used by weaving machines: the threads of the identity sub-braid can move in the braiding plane, but not moved by passable thread packages. It is precisely because of the fact that the threads do not braid with each other that passable thread packages can be avoided even while the threads move. Non-braiding threads are not subject the requirement of forming and breaking structural loops as the threads are moved. This opens up the possibility of using convenient thread movement mechanisms like heddles. This way of treating the threads belonging to the identity sub-braid significantly simplifies both the movements of the remaining passable thread packages, and the mechanisms themselves.

Bias Fibers

Bias weaves have other characteristics beyond the presence of a large identity sub-braid. The bias fibers, for instance generally move across the braid at a constant angle, not up and down. As a result, it is not necessary to be able to efficiently switch the vertical positions of spools in the absence of horizontal movement. It is important to be able to efficiently move large groups of bias spools sideways, though. It is also important to be able to produce a variety of braids with these descriptions. A column-based Cartesian braiding machine, with independently controllable columns, is well adapted to do exactly these things.

Fill Fibers

The final characteristic of bias weaves that we can take advantage of is the presence of fill fibers. The fill fiber is one yarn that crosses many other yarns at one time, generally moving all the way across the braid. These sorts of movements are the most frequent braiding movement in the production of bias weaves; it makes sense that the machine is arranged to facilitate this motion.

To do this, we can reuse the solution that is used in normal weaving: Move the other threads so that they are located on the appropriate sides of the shuttle path. Then move the shuttle through this shed, entirely across the weave.

Moving the threads to the appropriate side of the shuttle path (shedding) is made easier by the particular specializations already planned for the warp and bias fibers. Heddles obviously work well for shedding the warp threads. Columns can be positioned to place the appropriate spools above and below the shuttle path, as long as there is enough space between spools on the columns. A column-based Cartesian braiding machine is particularly well adapted to positioning the bias spools, since the spools will be riding up and down on one piece of structure during this process. That is, the spools do not need to be passed around to position them.

In using columns as a means of positioning the bias spools relative to the shuttle path, we are taking advantage of another characteristic of bias weaves: there is a definite “stacking order” of bias fibers. This means that it is unlikely that a fill pass will be required to pass

over the top spools on the column and under the bottom spools.

5.1.3 Pass Spools in Front of Reed Blades

As discussed in Section 4.4, the few braiding machines (excluding looms) that have beat-up mechanisms move the reed blades into the braiding area by inserting them from the side. The two problems with this is that an insertion movement is large (and so time consuming), and may risk catching yarns in the process.

There is a better approach: locate the reed blades so that the passing threads move in front of them. This prevents the blades from being entrapped in the braid. In some ways this is the same approach as before: moving the blades out of the braiding area. But it takes advantage of a previously overlooked out-of-the-braiding-area location, which is closer, reducing the time required, and involves moving along the threads instead of across them, thus reducing the catching potential.

5.2 The Concept

The chosen concept is shown in Figures 5-3 and 5-4. In this machine, the bias thread packages are placed on columns which are located in between groups of warp fibers. The unwoven warp threads spread to accommodate the size of the bias packages. Stacking the bias packages in this manner allows the spacing between warp thread groups to be kept reasonably small, the number of packages kept reasonably large, and (as will be shown) does not terribly harm the braiding ability of the machine. The columns can move vertically, and there is a mechanism, not shown, for moving the bias packages between columns at the weave level. The warp threads are moved up and down by a Jacquard machine, much like in normal weaving, and a fairly typical shuttle is used for filling. Reed blades also sit between the columns, and can be moved forward to compact the weave. Bias-package shifting, filling, beat-up, and take-up are the basic motions of the machine. Chapter 6 will show how these motions (minus beat-up and take-up, since those motions have no topological effect) combine to make bias weaves.

The columns must be at different angles (arranged in a circular pattern) so that the warp

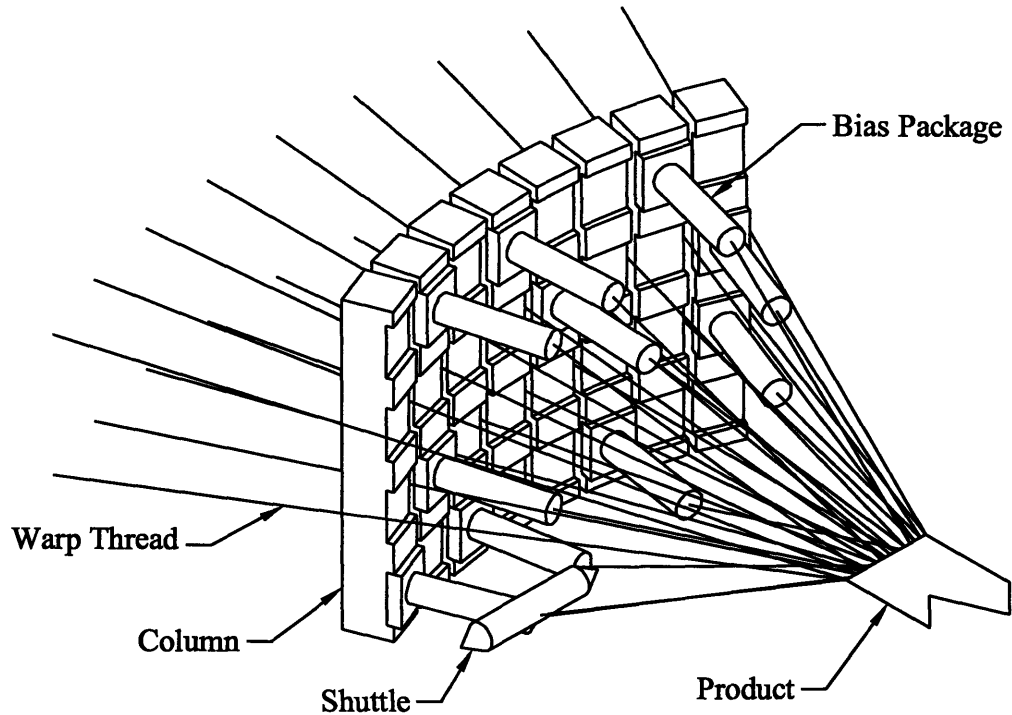

Figure 5-3: The Machine Concept, Isometric View

threads and reed blades can go straight between the columns and past the bias packages without turning any corners.

5.2.1 Bias-Package Shifting

This machine is configured to shift (sideways) one row of bias packages at a time. To accomplish this, the columns are moved up or down in order to line up the chosen bias packages—at most one from each column—along the shifting row. Simultaneously, the warp shed can be modified so that each warp fiber is above or below the shifting row, as desired. This configuration, called the bias shed, is shown in Figure 5-5. Then, all of the bias packages along the shifting row are shifted (together) sideways, left or right, as desired. This is shown in Figure 5-6.

The machine is designed to shift every spool that falls on the shifting row. So, if no spool is supposed to shift on a particular column, that column must place an empty bias position on the shifting row.

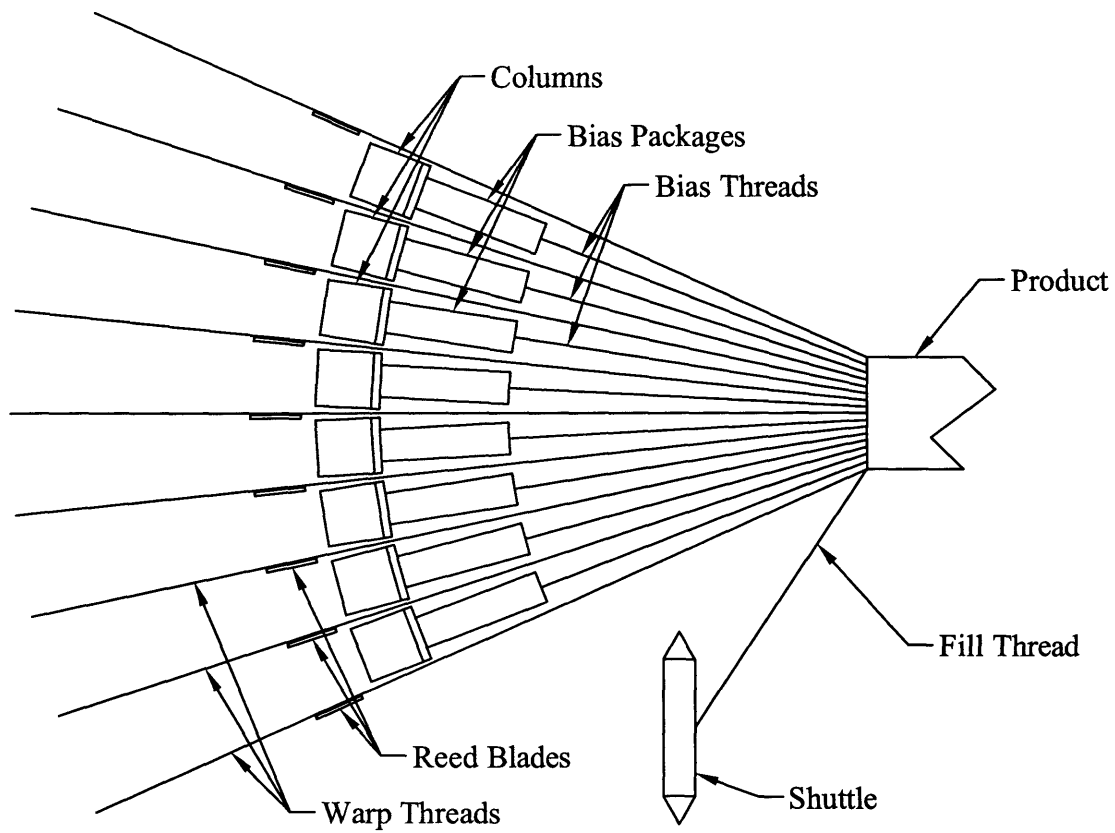

Figure 5-4: The Machine Concept, Top View

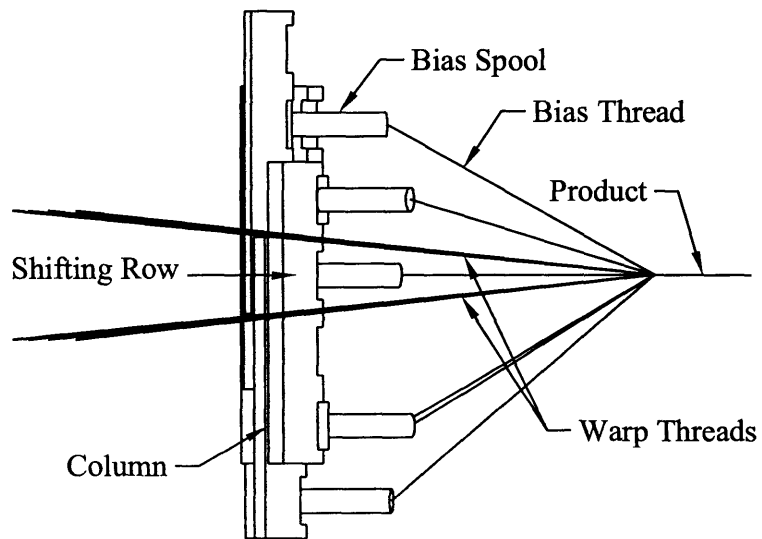

Figure 5-5: The Bias Shed

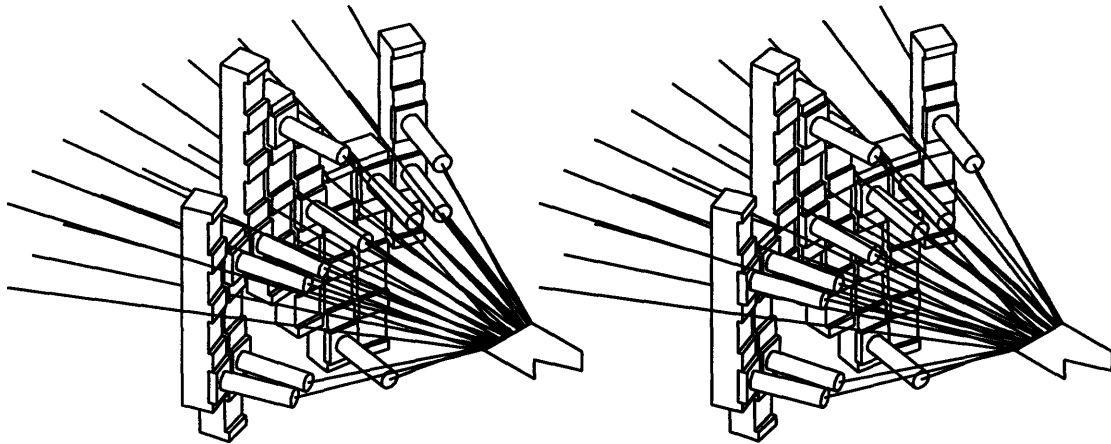

Figure 5-6: Shifting the Bias Packages

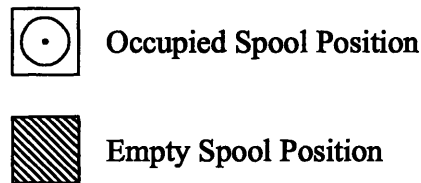
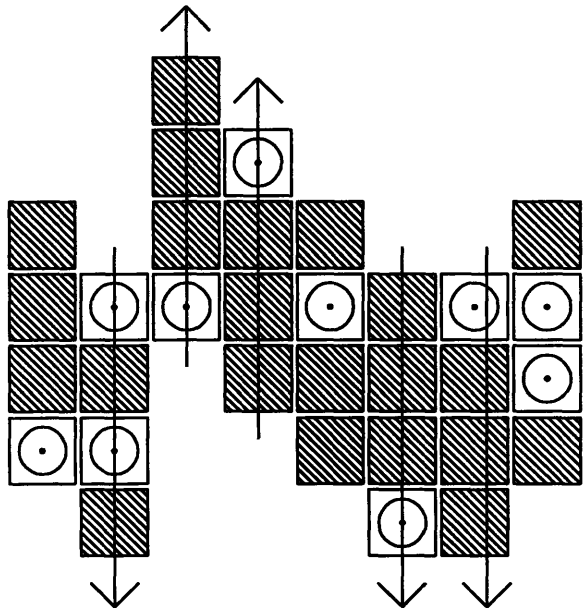

Figure 5-7: Schematic Diagram Key

It will be useful to establish a schematic representation of the bias spool configuration change. These representations will use the symbols shown in Figure 5-7, which represent the bias package positions on the columns, as if looking along the fibers from the finished weave.

One representation of the bias-shifting operation is shown in Figure 5-8. This diagram does not show the warp threads, but their existence and movement is implied. It does contain some redundant information, since which bias spools shift implies how the columns must be moved. A more compact representation is shown in Figure 5-9, where it is implied that the columns will need to be moved in order to line up the moving row.



Step 1: Move Columns Vertically

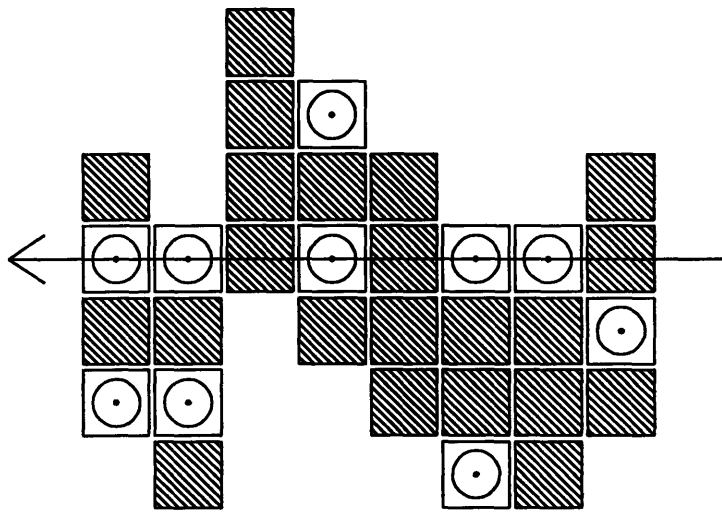

Step 2: Shift Row

Figure 5-8: Schematic of Bias Shifting

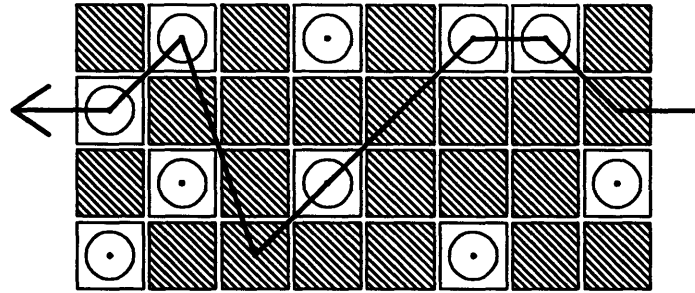

Figure 5-9: Another Schematic of Bias Shifting

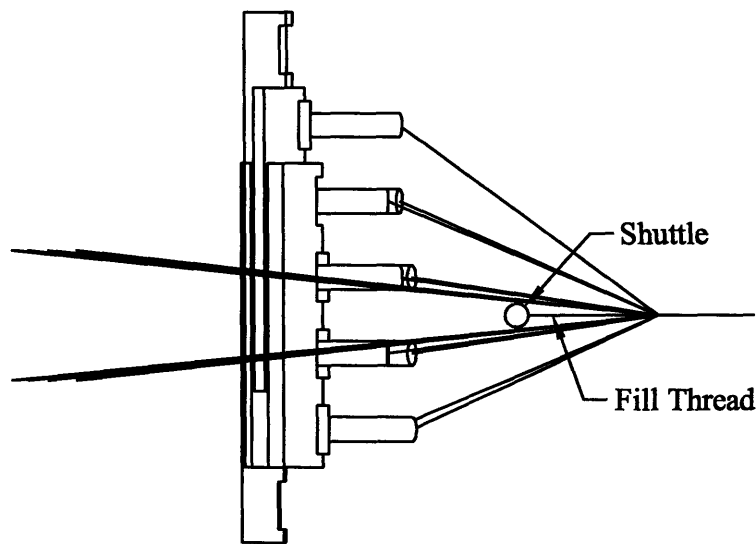

Figure 5-10: Fill Shed

5.2.2 Filling

When inserting a fill fiber, the columns are moved up or down to choose which bias spools the fill fiber passes between. Simultaneously, the individual warp fibers are moved up or down in order to choose which warp fibers the fill passes over and under. This process will be referred to as the fill shed, illustrated in Figure 5-10. After the fill shed is formed, the fill shuttle is passed through the shed, as shown in Figure 5-11.

A schematic representation of the filling process is shown in Figure 5-12. This indicates which bias positions the fill thread goes over and under, analogous to the bias representation in Figure 5-9. Again, the column movements that line up the appropriate column locations

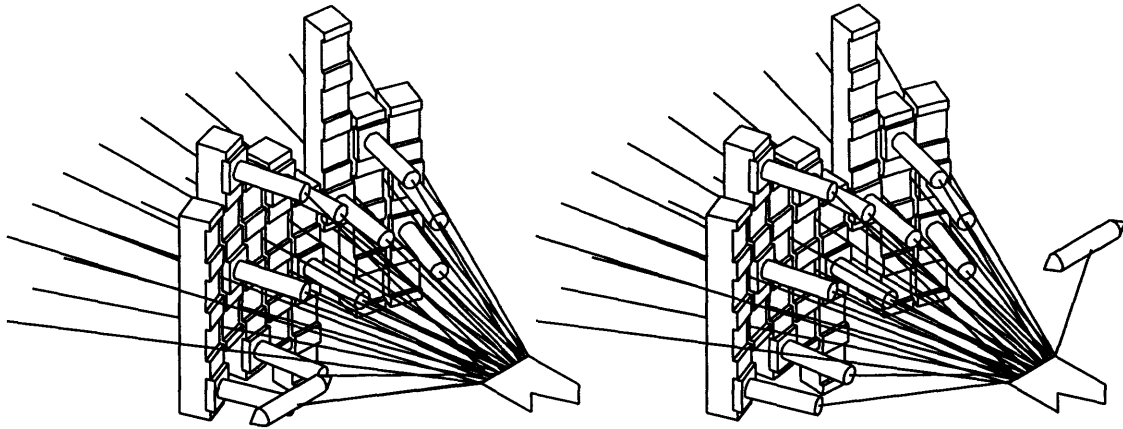

Figure 5-11: Passing the Shuttle

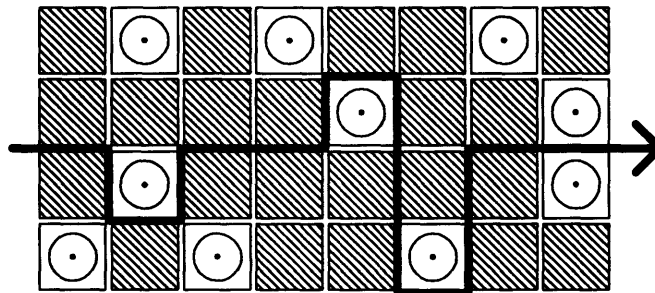

Figure 5-12: Fill Schematic

on the fill path are implied. Also, the warp locations are omitted.

5.2.3 Beat-Up

During beat-up, the reed blades move along the warp fibers to the fell, converging as the warp fibers do. The reed blades must be behind (farther from the fell than) any thread package that is being passed. Specifically, during bias shifting, the blades must be brought between the columns, so the bias threads pass in front of them. Similarly, the reed must be behind the shuttle when it is passed. These things are required so that the reed blades do not get woven into the braid. While beat-up does not affect the topology of the braid, it is highly desirable for ensuring regular geometry.

Chapter 6

Braiding on the Proposed Machine

This chapter will address the problem of which braids can be produced on the machine described in Chapter 5.

Section 6.1 shows that the machine can produce any braid among the bias fibers, as long as the machine has enough space for the required number of threads. These braids may require many steps to produce, and so are not useful in practice. This section is included largely emphasize the need to consider factors besides braidability. The remainder of the chapter will focus on braids that are produced more efficiently. This means large numbers bias spools will be shifted at once.

The approach to determining what can be braided efficiently on this machine is essentially constructive. In Section 6.2, a number of useful bias subweaves are presented. These are compounded together in Section 6.3. Problems in compounding this bias subweave with a $0^\circ/90^\circ$ subweave are explored in Section 6.6, by attempting to decompose a given braid into processes allowed by the machine. This constructive approach will not give every braid that the machine can produce, but will give many useful ones, with some assurance of efficiency.

Finally, the possibility of using multiple shifting rows will be explored in Section 6.9. It turns out to be useful only in very particular cases, and was not used on the built machine.

6.1 Elementary Braids

Chapter 3 showed that the ability to switch the position of any two adjacent fibers—in both a positive and negative twisting sense—is all that is required to produce any braid. The machine introduced in the previous chapter can do this if the warp and fill fibers are ignored and if there is one unoccupied bias position per column.

To show this switching operation, one must establish a mapping from bias positions on the machine to a line, as in Section 3.2.1. For convenience, one can use a mapping analogous to the mapping shown as Figure 3-7: Ordering goes first according to column, and then according to height on the column. Unoccupied bias positions are skipped. With this mapping, general braiding only requires the ability to switch—with either positive or negative twist—adjacent bias packages on each column, and the bottom bias package on each column with the top bias package on the next column to the right. These are all the adjacent threads, according to the chosen mapping.

Figure 6-1 schematically illustrates how to switch two adjacent bias packages on one column. As will be typical in these diagrams, only the bias positions that are used in the operation are shown, and arrows show the operation that has just been completed. In this switching operation, the bias packages are moved first into the empty spool positions on the next two columns, and then back into their new positions. As shown, the bias packages switch in a positive sense. If spool “A” was moved first, they would have switched in a negative sense, instead.

If there are not two columns to the right, the spools could have been initially moved to the left, instead. Similar patterns can be used to switch the bottom spool on one column with the top spool on the next.

From this, one can conclude that this machine can braid, amongst the bias fibers, any given braid. Unfortunately, producing braids by successive multiplication of elementary braids—each requiring eight steps—would be impractically slow. Compare this to standard weaving, where one fill fiber pass produces—in one machine step—as many elementary braids as there are warp fibers. More efficient patterns of operation will be discussed below.

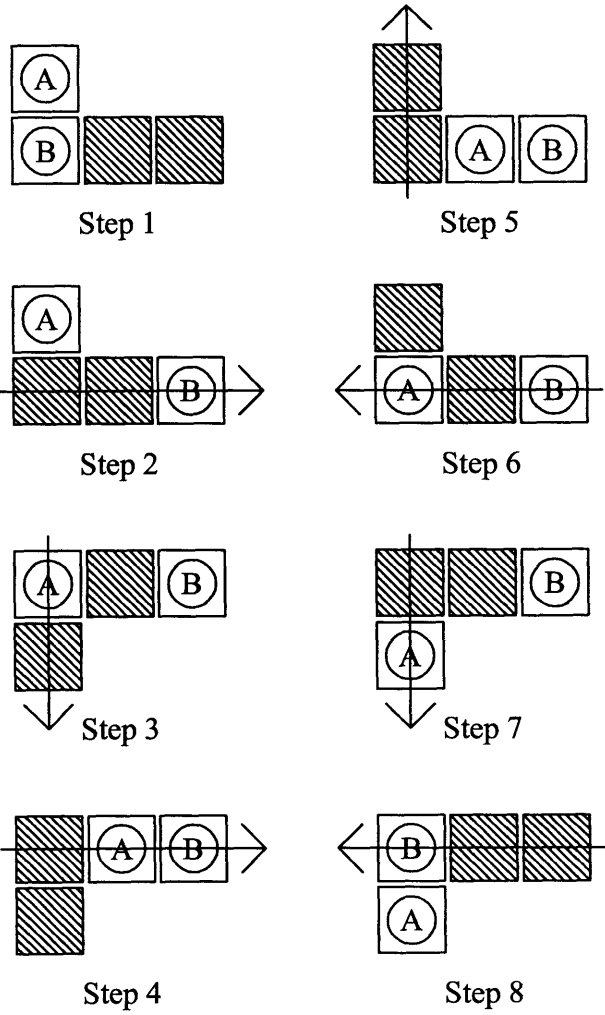

Figure 6-1: Producing an Elementary Braid

6.2 Simple Bias-Bias Subweave Patterns

It seems likely that there three basic things that the bias fibers should be able to do in a particular bias layer:

- Move left and right as the weave progresses, in non-interwoven sheets.
- Move left and right as the weave progresses, in interweaving sheets.
- Turn a left-moving bias fiber around to become a right-moving fiber, and vice-versa.

The proposed machine can do these things and more, as demonstrated below.

Consider the four-step process shown in Figure 6-2. This process will move the bias threads to produce the braid shown in Figure 6-3. Most likely, tension or braided-in constraints (such as tying to a base weave) would cause the threads to be straighter, as shown in 6-4. This is an equivalent braid.

The whole four-step process can be represented schematically as in Figure 6-5. The diagram implies that a left shift must occur first, because if it did not, the spool on the right would fall off the end of the machine. The arrows and lines superimposed on the bias positions indicate which bias packages are involved in which shift. They imply the vertical column movements that are necessary to line up the shifting threads.

This braid demonstrates the three basic items that one would like to produce (non-intertwined and intertwined layers, turns). The corresponding patterns that produce them can be seen in Figure 6-5: Turns occur when there is no column movement between the right and left shifts, so that one bias package is moved by both. Non-interwoven sections of the subweave are produced by parallel paths on the columns, while interwoven sections are produced by crossing paths. The sixth column is used for the production of two separate braids; this may be useful at times.

Of course, variations on these patterns are possible. For instance, one could easily make a non-interwoven sheet where the right-moving threads are on the bottom, instead of the top. Or one could make an interwoven sheet where the right-moving fibers are on the top for two columns, then on the bottom for one, etc.

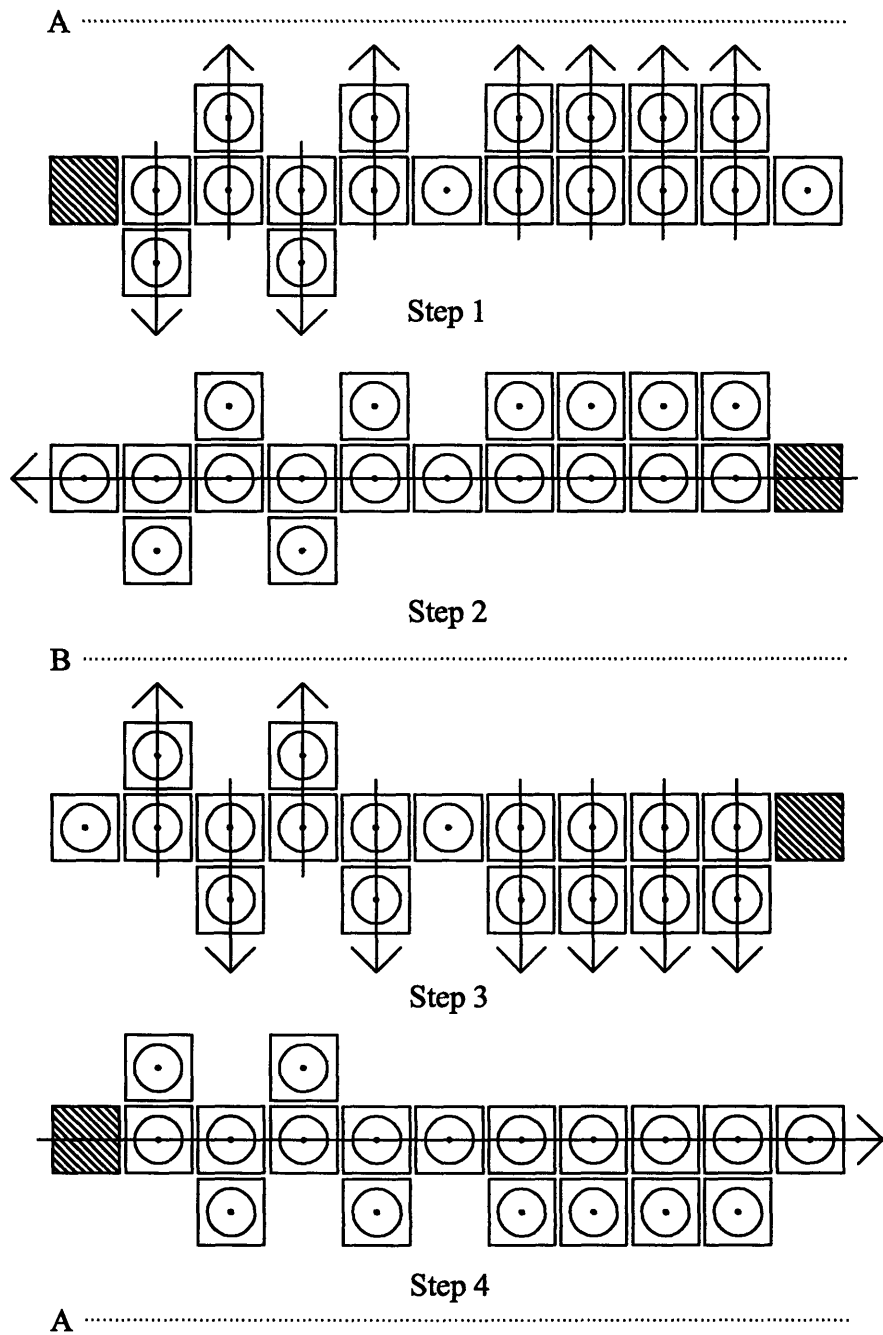

Figure 6-2: Example Bias-Shifting Process

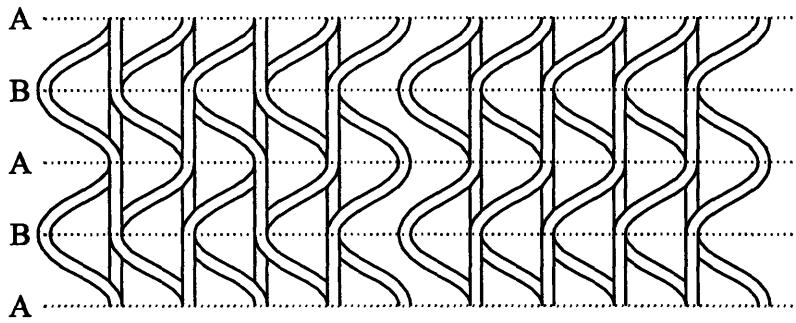

Figure 6-3: Bias-Shifting Process Result

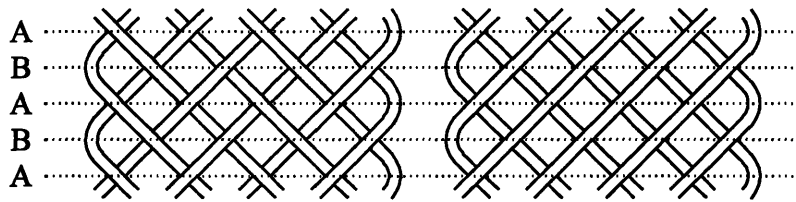

Figure 6-4: Bias-Shifting Process Result, Straightened

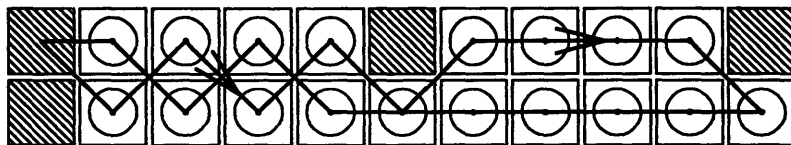

Figure 6-5: Example Process Schematic

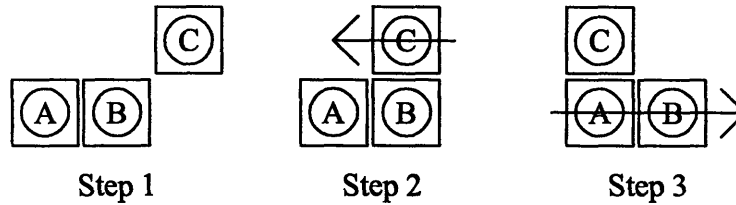

Figure 6-6: The Coupling Problem

Uniaxial bias layers are rather trivial to create—one simply shifts the row in the appropriate direction—but do not make sense in isolation, because other uniaxial bias layers are needed to supply the bias spools on one side, and capture them on the other. The transition between one uniaxial layer and another would look just like a turn in a non-interwoven $+45^\circ / -45^\circ$ sheet, except there would possibly be other bias spools (involved in other bias layers) between the left- and the right-moving parts.

6.2.1 Limitations in Simple Bias-Bias Subweaves

Notice that in Figure 6-4, the interwoven bias fibers have an over-over-under-under pattern. This is a machine limitation that results from coupling between crossings.

The problem can be explained by using the example process shown in Figure 6-6. If we assume the same ordering as in Section 6.1, then Step 2 produces a positive (counterclockwise) twist between fibers B and C. Step 3 produces a positive twist between fibers A and C. If one wanted a negative twist between A and C, the bias package A would have to be put above bias package C. To do this and still move bias package B to the right, one would need extra unoccupied bias positions, and an extra column and shift operation. In other words, decoupling the two crossings requires extra operations.

One way to get around this issue is to place the bias spools half as densely on the columns. A schematic of the process, and the resulting braid, is shown in Figure 6-7. Here, an over-under pattern is made. Incidentally, this is the same solution that is used to get over-under patterns on horngear braiding machines. The one complication with this approach is that the turns become more difficult. If they are done as discussed above, the every-other-column spacing gets disturbed. This is corrected by letting spools delay on the turning column,

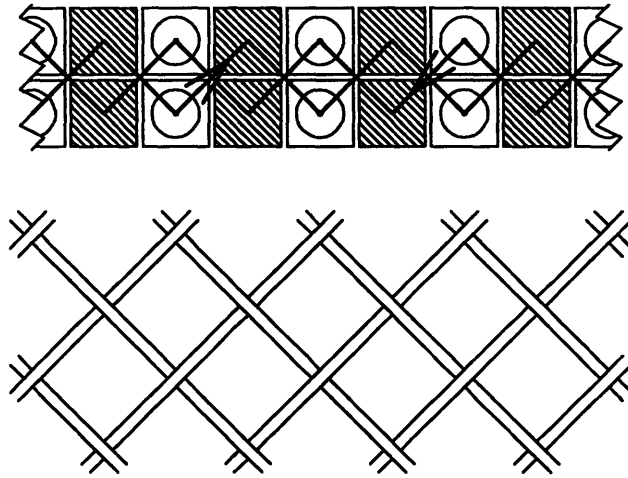

Figure 6-7: A Way to Fix the Coupling Problem

rather than shifting immediately.

Half-density weaving has another advantage: it provides a convenient way for the weave to evolve as it progresses. All of the bias spools on the occupied columns can be arbitrarily restacked as they move onto the empty columns. This provides a relatively efficient way to step outside the initial pattern. This mode of operation will not be further addressed here, in the interest of using the maximum number of bias fibers on a given machine.

6.3 Compound Bias Subweaves

One can compound the bias subweaves by taking the patterns in Section 6.2 (including the uniaxial bias subweaves), and distributing them among the bias package locations on the columns in such a way that their vertical stacking order on the columns corresponds to their actual stacking order in the weave. An example is shown in Figure 6-8.

Such a diagram corresponds roughly to the shape of the bias layers in the braid cross-section. For example, in Figure 6-8 there is a flat, interwoven bias layer that crosses the tails of a non-interwoven, α -shaped bias layer.

The imprecision of the bias subweave language shows a little here. There are many cases where one could mentally split the compound bias subweave in different ways. For instance,

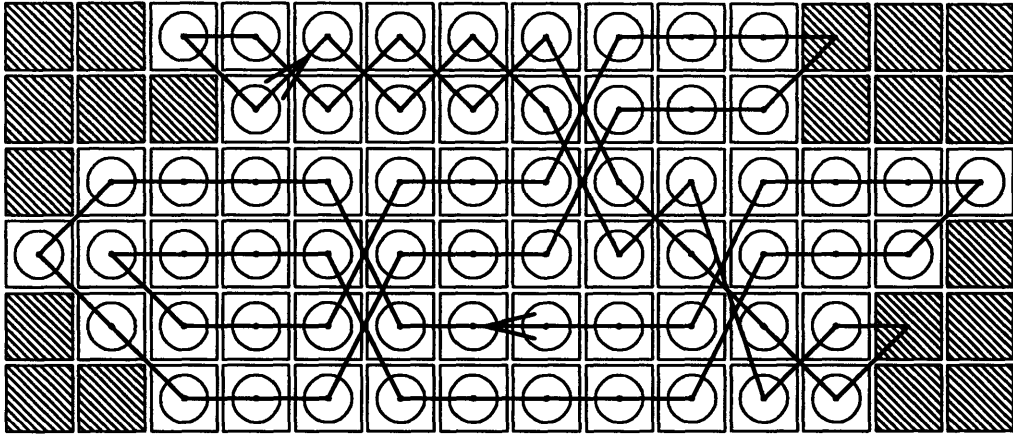

Figure 6-8: A Compound Bias-Weave Process

there is not necessarily a clear distinction between two parallel uniaxial bias layers and a single non-interwoven biaxial bias layer. The idea of simple bias subweaves works better for constructing bias weaves than deconstructing them.

6.3.1 Shift Planning

To advance all the bias spools by one column, the machine must perform as many shifts as there are uniaxial bias layers. That is, a biaxial layer counts as two uniaxial layers. For example, the braid in Figure 6-8 requires six shifting operations.

A certain amount of planning is necessary. For instance: Each left shift moves a bias package out of the column on the right side of the layer (where a turn occurs) and deposits another in the column on left (where another turn occurs). One needs to make sure there is a bias package in the right column, and is not one on the left.

For the purposes of planning the shift order and the initial locations of the bias packages, it may be useful to think of the shift operation as actually moving a spool from one end of a layer to the other. A graph such as the one shown in Figure 6-9 may be useful for representing where shifts move the bias packages to and from. This graph is produced by removing all but the turn positions from Figure 6-8. It can be seen that as long as there is at least one empty and one occupied bias position per loop, then a sequence of shift operations can be concocted to shift every edge in the graph exactly once.

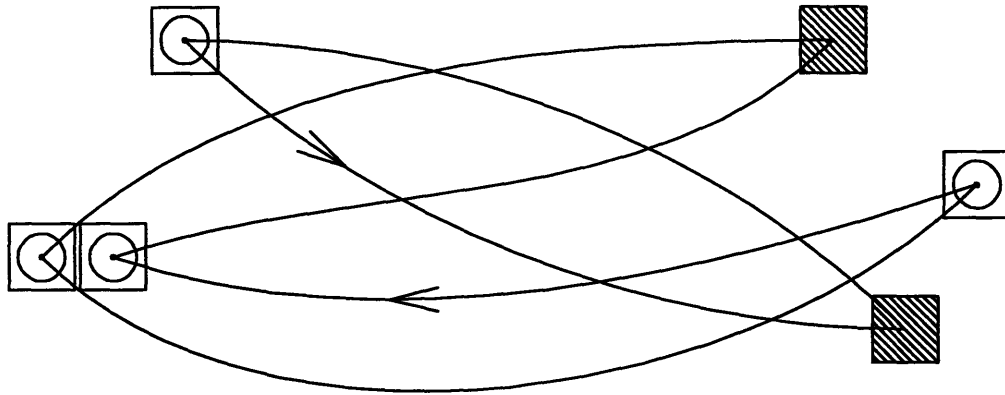

Figure 6-9: Shift Planning Diagram

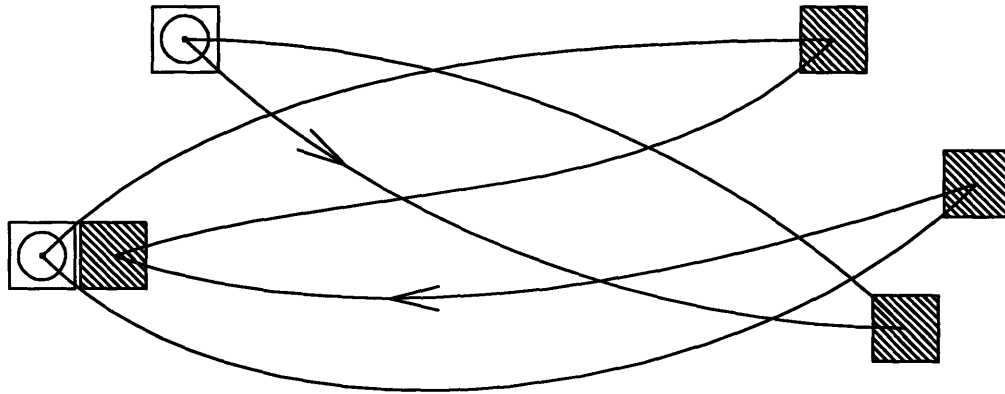

Figure 6-10: A Convenient Shifting Method

One straightforward way of structuring the shifting is to put only one turning spool in each loop, as shown in Figure 6-10, and perform the shifts that push it completely around the loop. Of course, the bias spool layout on the machine (Figure 6-8) must be correspondingly modified.

If a loop has multiple direction changes, this method may not result in the minimum number of shifts. One method that will result in the minimum number of shifts is to fill all the left-to-right turns on a loop (for instance), and leave the right-to-left turns unoccupied, as shown in Figure 6-11. One would then execute all the right shifts first, then all the left shifts. This may reduce the number of shifts required by allowing one to simultaneously shift multiple “legs” of a loop (or multiple loops) if they do not share any columns. This will

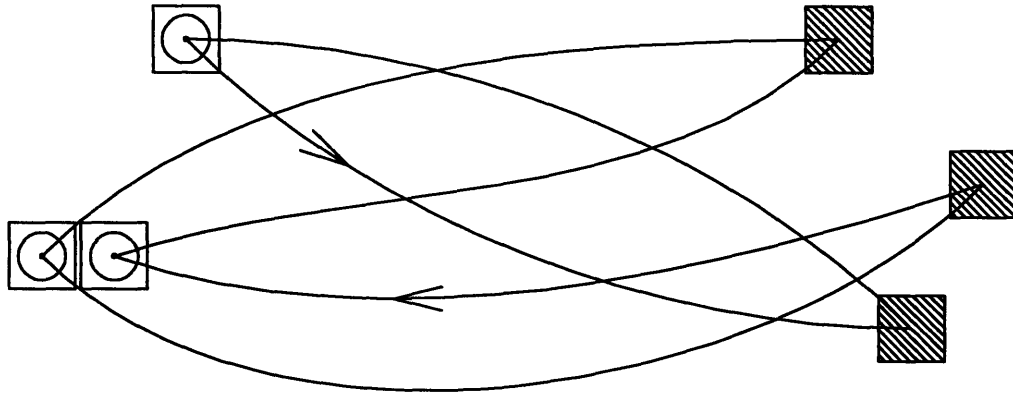

Figure 6-11: Another Convenient Shifting Method

happen, for instance, if the bias spools trace around the outside of an I-shape in the weave cross-section.

All the examples given above return the spool configuration to the original state after advancing the bias spools one step. There are other possibilities that would return to the original configuration after multiple shifts. These cannot be drawn as a single loop on the bias spool array. For instance, one could use two bias spool positions at every turn instead of one, with one position always occupied at all corners at the beginning of the shift sequence. This may give more right-left symmetry, but requires alternating the shifting pattern to avoid shifting into an occupied position or shifting out of an empty position.

6.3.2 Limitations in Compounding

There is an aspect of the compound bias subweave which is not necessarily up to the weave designer. When two threads moving in the same direction cross, the sense of the twist that is created is dictated by the order in which the two threads move. This is illustrated in Figure 6-12. If bias package A is shifted first, the threads get negative twist. If B moves first, the threads get positive twist. In a given weave, one may not be able to choose which spool shifts first, due to the constraints of shift planning.

This is an example of how, at this level in the weave, the geometric relationship of the subweaves is more useful to think about than the topological relationship. One probably

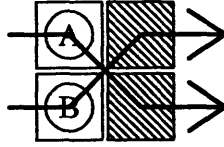

Figure 6-12: The Same-Direction Crossing Problem

does not care about the details of such the crossings. On the other hand, for example, there is likely a close connection between the function the final braid, and the idea that two bias layers should form an “X” in the cross-section.

6.4 The Bias-Warp Subweaves

With a single shifting row, every warp thread is crossed by at most one bias thread at a time. Since each warp thread can be placed above or below the shifting row, the designer can choose the sense of each thread crossing. There are no restrictions on the crossings in a particular bias-warp biaxial subweave.

This situation is similar to fill insertion in normal weaving. The designer lifts the appropriate warp yarns to create the chosen path of fill through the weave. The difference here is that many bias threads share that same path, and they may even belong to in different bias layers.

6.5 The Bias-Fill Subweave

The situation is the same with the bias-fill subweave if one considers only a single bias thread per column. In this case, the columns can be moved up or down—as if they were heddles—to place the bias threads above or below the fill yarn, at will. Bias threads behave basically like warp threads during filling.

Things change slightly when many bias threads on a column are considered, because the bias threads that share a column cannot be moved independently. For instance, if one bias thread stays above the fill, then so will every other bias thread that is located at a higher

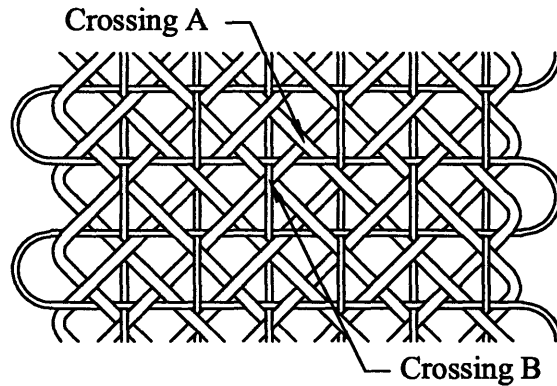

Figure 6-13: Impossible Weave

position on that same column.

This restriction may be circumvented by using multiple fill passes. If bias fiber A is located over bias fiber B on a column, then three fill passes can route a fill fiber over A and under B . Fortunately, geometric considerations mean that this is not so important. If the bias layer containing A is above the one containing B in the weave, there is little motive for introducing such a pathological fill fiber.

6.6 Axial-Bias-Fill Restrictions

The ability to braid all the appropriate sub-braids does not guarantee the machine's ability to braid the complete braid. Equivalent sub-braids do not guarantee equivalent braids. Eventually, everything must be looked-at together. An example will clarify this. Consider the braid shown in Figure 6-13. Each biaxial sub-braid is braidable, according to the previous discussions. However, the complete braid is not efficiently braidable.

To determine whether this braid can be produced on this machine, one can try to fit the braid to the operations allowed by the machine. If (and only if) the weave is braidable on this machine, it can be partitioned—by deforming the braid, without passing threads through each other—so that each piece of the braid corresponds to an allowed operation.

For each operation, threads are either stationary or moving: stationary threads remain in their respective locations, while moving threads move in the allowed ways. Places where

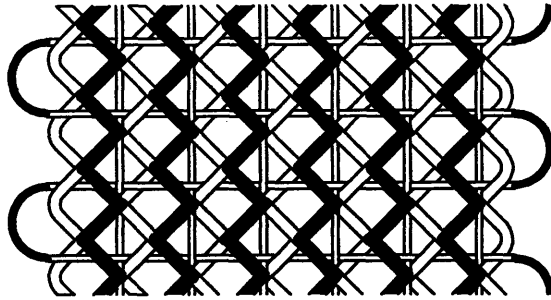

Figure 6-14: Impossible Weave, Stationary Threads Darkened

threads are stationary (or can at least be considered to be stationary) can be picked out in the braid projection. Fill fibers are stationary when they are not crossing the weave. Stationary bias threads can also be recognized, since they are the ones that stay on the top or bottom. Figure 6-14 shows the weave with all the stationary threads darkened. All threads that are not darkened are moving. Note that the zig-zagging darkened sections of thread also indicate the locations of the columns.

One can now try to partition the weave by deforming it in such a way that every piece has a movement allowed by the machine. For the weave in Figure 6-14, notice that the moving bias threads form a set of nearly continuous zig-zags in the weave direction, broken only at the corners. There is no machine operation in which the fill and the bias threads are moving at the same time, so if the braid is weavable by this machine, it must be possible to distort the weave so that the fill crosses only the corners of the dark zig-zag, since that is the only place in the weave where the bias threads are not moving.

Consider the fill thread between Crossings *A* and *B* in Figure 6-13. It must be moved either to Crossing *A* or Crossing *B*, since those are the places where the bias fibers are not moving. There is a stacking order problem in either case.

At Crossing *A*, the fill fiber is over the $+45^\circ$ thread and under the -45° thread. But the $+45^\circ$ thread is over the -45° thread. There is no acceptable stacking order for the three threads. This indicates that the fill fiber cannot be simply moved over Crossing *A*. It could be moved over the crossing if the fiber went left over both bias threads, right between the bias threads, and left under both bias threads. That fill thread actually represents not one

operation per fill crossing, but rather three per bias crossing per fill crossing.

A similar situation occurs at Crossing *B*, but in that case the warp fiber would have turn around, looping back along the weave direction. This is something that the machine cannot do. Since neither of the two options works, the machine must be unable to produce this braid efficiently.

6.7 A Criteria for Braidability

The example above illustrates enough of the process-fitting problem to recognize when a braid is actually braidable. A simple criteria for braidability on this machine that it must be possible to deform the braid so that:

- The bias subweave is valid
- The fill threads occur at the bias crossings
- The warp threads occur between the stationary bias threads

Notice that the last item is equivalent to saying that the warp fibers occur between the columns. This occurs if the warp fibers run across half the bias crossings, as is the case in Figure 6-13.

6.8 Cross-Section Representation

This criteria for braidability suggests a way of envisioning bias weaves. Fill cross-sections are created around stationary warp and bias threads. Then bias threads are advanced past stationary warp threads. A cross-section representation, such as Figure 6-15, provides a good illustration of the weave, at least if a weave repeats often enough.

This diagram is similar to the standard weave cross-section (Figure 3-12), but also indicates where the stationary bias threads are located with respect to the fill threads, and where the moving bias threads are located with respect to the warp threads. Such a diagram highlights how the bias threads behave like warp threads during filling, and like fill threads during shifting.

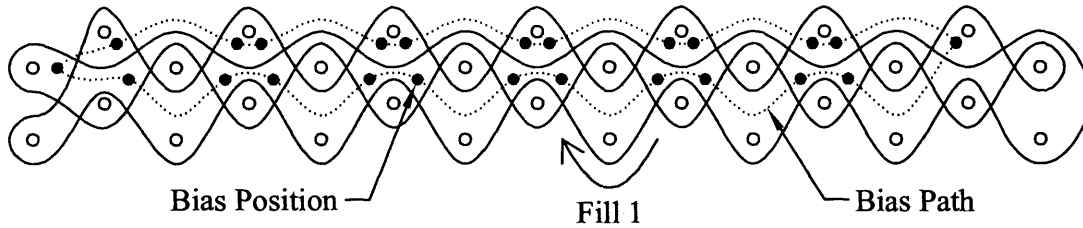

Figure 6-15: Cross-Section Representation of a Bias Weave

It also shows much of the same information as the diagram of the bias array layout (Figure 6-8). In this case, the reader can see that the bias pattern is a single non-interwoven biaxial bias layer. The diagram idea extends easily to multilayered bias weaves.

The representation shown omits some important information. The initial locations of the bias spools and their direction of movement are missing. As is a description of when the shifting should occur relative to the filling. For instance, one may execute all four picks, advance the bias threads, repeat. Or one may execute picks one and two, advance the bias threads, execute picks three and four, advance the bias again, then repeat.

6.9 Multiple Shifting Rows

One might wonder if there are advantages to multiple shifting rows. Any advantages would only be in terms of time, not in terms of which weaves could be produced. The reason is that if a weave can be produced by shifting two rows, it could also be produced by shifting one row and then shifting the other. As it turns out, only a small number of braids could take advantage of the two shifting rows.

Suppose the shifting rows were adjacent to each other and working the two halves of the same $\pm 45^\circ$ bias layer, as shown in Figure 6-16. One problem is that the two layers could not interweave. A second problem is that the column on the end moves upward only. Eventually one would run out of column. Note that this cannot simply be solved by moving the column back down, since the column always contains a bias thread—moving the column downward would interfere with its proper movement. One solution is to use a auxiliary piece of machinery to make the turn. The price is complexity, and likely a fixed bias layer width.

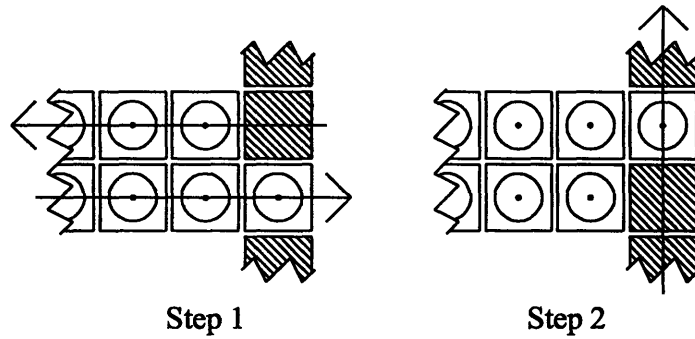

Figure 6-16: Shifting Two Adjacent Rows

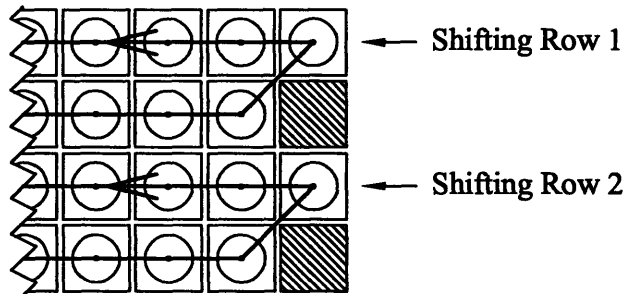

Figure 6-17: Shifting Two Non-Adjacent Rows

Another configuration uses two non-adjacent shifting rows. This is shown in Figure 6-17, with two shifting rows separated by one nonmoving row. In the configuration shown, the machine would weave two parallel $\pm 45^\circ$ loops. Within each loop, the operation would be similar to as with one shifting row. It could take advantage of the parallel moving rows in any weave that is formed by strictly parallel paths. Unfortunately, this is quite a restriction.

Chapter 7

Comparisons and Conclusions

The proposed machine has more in common with conventional braiding and weaving machines than existing bias-weaving machines. Perhaps it can be more appropriately seen as a braiding machine with certain elements—both mechanical and philosophical—of weaving machines, with some new ideas added as well.

7.1 Manipulation of Thread Ends

While the product produced by this machine is typically called a bias or multiaxial weave, the production process is different than the process used by other bias-weaving machines, such as the carousel-type and identity-braid machines. Those machines are characterized by poking bias threads through the weave to form a sort of shed for the insertion of fill threads.

In contrast, this machine creates the braid topology solely by manipulating the thread ends—or in the case of the heddles, a portion of the thread that could be an end—instead of manipulating the middle of threads by poking, forming loops, etc. The middle of the thread is only involved in enforcing geometry during beat-up.

The machine shares this property with conventional braiding and weaving machines, which all create topology by moving thread ends (or eyelets containing the threads) around the braiding surface, with little reliance on exactly how the threads behave between the braiding surface and the finished product. The spools or eyelets that contain the thread do not regularly engage and disengage with the thread and, unlike the thread itself, can

designed specifically for the purpose of reliable manipulation. This is largely responsible for these machines' ability to avoid snags and caught threads.

The mechanisms on the proposed machine to manipulate the warp and fill ends resemble those used in normal weaving machines, with the exception of the distorted geometry: long shed, spreading fibers, etc.

The mechanisms used to manipulate the bias ends resemble braiding machines, specifically the so-called 3D braiders. The braiding-machine-like parts bear particular resemblance to Cartesian braiding machines where the spools are organized into moving columns and rows, especially the machines in which each column is a structural unit and there is some other mechanism to move spools between columns [12, 14].

7.2 Specialized Mechanisms for Specialized Braids

The proposed braiding machine is not intended to produce all sorts of braids. Of the braids it can theoretically produce, only certain kinds—bias weaves—can be produced reasonably fast. Designing for a particular type of braid allows both simplified machinery and improved operation on those particular braids. These ideas guided the concept development, as discussed in Section 5.1.2.

This sort of specialization is seen in weaving machines, which can only produce a certain class of braids—weaves—but can produce them remarkably efficiently. Similarly, the braiding machines that are used most in industry are horngear-type braiding machines, and these are also specialized for particular braids. They produce only one braid (or a few variations on that one braid), determined by the shape of the thread carrier tracks.

On the other hand, some other types of braiding machines, such as the 3D-Solid machine, can produce every braid that has sufficiently few yarns. These general braiding machines are less specialized, and correspondingly less simple and less used.

7.3 Different Threads Roles

One way in which this specialization takes place is by exploiting the different roles that threads play in the braid. For instance, in the bias-weaving machine, the shuttle takes advantage of the fact that the fill runs across a large portion of the braid in the width direction, the heddles take advantage of the fact that the the warp threads are part of the base identity braid, and the bias spools are designed specifically for their role lingering between sets of warp threads.

Specialization of thread roles is nothing new, except the choices are specific to bias weaves. Traditional weaving machines make the distinction between warp and fill threads. Most braiding machines make a distinction between axial and braiding threads.

It seems that the 3D braiding machines have less distinction between threads. Many 3D braiders seem to be specialized for braids which are homogenous in a sense. With the exception of the axial threads, all the threads are behaving in similar ways, specifically moving at similar speeds, more-or-less straight across the geometric cross-section of the weave. It is not surprising that there is some similarities between machines designed to make homogenous braids and those designed to make any braid. In both cases, particular threads do not have, on average, special behaviors.

7.4 Warp Threads

The most important distinction between thread roles is special treatment of the threads that form the base identity sub-braid, the warp threads. Since these threads do not braid with each other, they can be moved around the braiding plane without ever being structurally released. As discussed in Section 3.2.5, this means one can use something like heddles, which remain permanently engaged with both the yarn and actuating parts of the machine, instead of a device that is passed by making and breaking structural connections as in a bias spool or shuttle. It also means the thread need not end at the braiding plane, but rather can pass through to end at some indefinite grounded location beyond the braiding apparatus.

These differences are very important, for three reasons. First, passing an object from

one structural connection to another is not easy, since there is necessarily an over- or underconstraint problem in the transition. Being able to maintain that permanent connection avoids this problem (discussed further in Section 7.7). Secondly, continuing the threads past the braiding plane to some remotely-located and grounded location alleviates some design problems associated with passable thread packages, such as tensioning and size limitations. Thirdly, there are specific thread manipulation devices for warp threads—such as heddles and Jacquard machines—that are very practical, and can operate very quickly.

7.5 Correlations in Thread Movements

Another way in which specialization may occur is the choice of which thread movements are natural for the machine. Certain braids may be characterized by some relation between thread movements, and one then has the option of mechanically embedding this relation in the braiding machine, if it is helpful to do so.

For example, the proposed bias-weaving machine takes advantage of the fact that all the bias threads move at the same speed across the braid. It is useful to take advantage of this fact in shifting entire rows at once. In a similar way, the simultaneous movement of multiple rows or columns on Cartesian-type braiding machines is consistent with braids in which the threads all move at the same rate in a few different directions. In weaving machines that use a dobby, there is a strict correlation between the thread movements which arises from the fact that heddles are located on common frames. These machines that are designed for one type of braid cannot easily braid other types, because of the conflict between the thread movement correlations in the braid, and those in the machine.

The proposed bias-weaving machine can actuate the warp threads independently, even though the movements are not arbitrary. Certain warp threads are above or below other warp threads in the braid. This means if the bottom thread is up, so is the top thread, and if the top thread is down, so is the bottom thread. This is an identifiable correlation that is not reflected in the machine, because it is not useful to do so. Specialized braids increase the number of options the machine designer has, but does not dictate that the more-specialized option must be taken. Indeed, one probably wants to preserve generality if there is no severe

penalty for doing so.

7.6 Geometry on the Braiding Plane

Since the topology of the braid is created by thread end movements in geometrical space, there is necessarily going to be some connection between the geometric arrangement of threads on the braiding plane and the topology of the braid. For instance, if a thread crosses below some bias spool on the proposed machine, it also crosses below all the other bias spools that are above that bias spool. This is a correlation among crossings that results from the geometric arrangement of the spools.

Fortunately, this is also a correlation that one would likely want. The kinds of braids that people want are those that are geometrically sensible. People want the threads to “drive around” the braid cross section in reasonable ways. This can be accomplished by driving the thread carriers around the braiding plane in the same ways.

Of course, a braider does not need to use the desired geometry of the braid in this way, it just needs to get the topology right. But using the braid geometry has advantages. As a very rough approximation, the distance a thread moves is the cost of executing that braiding step (as opposed to the number of crossings, which may depend on the braid description being used). Mimicking the geometry of the braid on the braiding plane prevents the distance threads move from being unnecessarily large. This was discussed more particularly with relation to bias threads in Section 5.1.1.

Because of this concern for distance travelled, the arrangement of threads on the braiding plane in most braiding machines reflects the geometrical arrangement of threads in the braid. For instance, the 3D braiders producing an I-beam often have an I-shaped arrangement of spools on the braiding plane (See figure 4-8). Similarly, the arrangement of spools on most horngear braiders looks like the shape it is braiding.

As with the other braiding machines, the bias spools on the proposed machine are arranged similar to how they are located in the braid, except larger due to the size of the spools. However, the warp threads do not closely mimic their location in the braid. This is also the case in normal weaving machines. It is an indication of how distance traveled

is inadequate as a measure of the cost of performing thread movements—there are other reasons why some movements are easier than others.

7.7 Non-Passing Movements

Certain thread movements involve passing a thread: releasing it from one structural connection and connecting to another. Passing is necessary to move that thread across some other thread’s path, which sits in the “gap” between the two structural connections. As discussed in Section 3.2.5, passing movements are necessary to produce non-identity braids. In the proposed machine, passing movements occur when passing the shuttle across the braid or shifting the bias threads.

Other movements do not require passing. In these cases, the threads move between positions that do not require making and breaking structural connections. Warp threads, as discussed above, can use heddles, which have the distinction of only executing non-passing thread movements.

The distinction between passing and non-passing thread movements is important because passing thread movements are more difficult, since the thread carriers are over- or underconstrained as they make the transition from one side of the gap to the other. This means that the hardware involved may need to work slower, and probably needs to be more accurately made.

One can often replace a single passing thread movement with a combination of non-passing thread movements and an easier passing thread movement, resulting in a net savings of time. “Easier” typically means straighter, and over less distance. In normal weaving, as with the proposed bias-weaving machine, such a situation occurs when one first uses heddles to position the warp threads, and then executes a single, straight, passing operation with the shuttle. This obviates the need to have tortuous shuttle paths that weaves above and below the warp threads. This points to another advantage: fewer passing routes, since the same path makes the passed thread go over or under non-passing threads according to their previous non-passing movements. The benefit of this is mechanical simplification.

Typically, in using such a combination of passing and non-passing movements, the geo-

metric arrangement of threads on the braiding plane becomes less like the geometric arrangement of threads in the braid, since the braid is being distorted to straighten thread paths. One may still get an advantage in time, even though threads move larger distances. The geometric-similarity rule of thumb, described in the previous section, seems to be broken mainly for this reason.

The proposed braiding machine takes advantage of non-passing operations whenever possible, and in this way is closer to weaving machines than braiding machines. As in normal weaving, the warp threads execute non-passing thread movements to the advantage of the filling operations. One suspects filling would be impractical any other way. The bias-weaving machine extends the heddles' role to bias shifts as well. This is one of the things that allows a single shifting row to be used.

In addition, the bias threads undergo non-passing operations in both filling and bias shifting, when the columns move up or down before the respective passing movements. This is an example how a thread can undergo helpful non-passing movements at times, even if it must perform passing movements at other times. The closest approximation of this in prior art is in the Cartesian braiding machines where columns form structural units, but no filling operation is performed there.

Most braiding machines do not take advantage of non-passing thread movements. In a typical horngear braiding machine, threads only move in thread carriers, and every time a thread carrier crosses another carrier's path—which presents itself as a gap in the carrier guide—it is structurally released from the hardware on one side of the intersection and captured by the hardware on the other. Similarly, in the 3D-Solid machine, a passing operation occurs every time a spool moves between rotors. Cartesian braiding machines in which thread carriers are constrained both vertically and horizontally by neighboring carriers (that is, they press directly on each other) can be considered to always execute passing movements, since the objects constraining each spool change with every movement. There are, however, a few circular braiding machines that use non-passing thread movements. These are discussed in the next section.

7.8 Crossing Multiple Threads Simultaneously

A single passing thread may cross the paths of multiple non-passing threads. That is, multiple non-passing threads may sit in the gap. This is useful because each extra non-passing thread often adds little to the length or difficulty of the pass, as compared to multiple passes.

This occurs in standard weaving machines, where the fill thread crosses all of the warp threads at one time. In the proposed bias-weaving machine, the fill thread passes both the fill and bias threads at once. The moving bias threads pass all the fill threads in a particular dent at once.

This is another example of braid specialization being reflected in the braiding machine. The bias-weaving machine embodies the fact that a moving bias thread should cross, at one time, all of the warp threads at some particular position along the width of the weave. Similarly, both normal and bias-weaving machines reflect the fact that fill threads typically cross all the other threads at once. It is true that sometimes one only wishes to move the fill yarn halfway across the weave. In these cases, one must cross the other half, and uncross it in the next movement. But since the extra distance comes so easily, it makes sense operate in this manner.

As noted before, most braiding machines do not take advantage of the special nature of non-passing thread movements. However, there are few circular braiding machines which do use warp-like thread movements to determine how passable threads cross other the other threads [9, 11, 2]. Unlike the proposed braiding machine, none of these machines cross multiple threads in a single gap, and none have heddles in the traditional sense.

7.9 Putting the Reed Behind Passing Threads

Non-passing threads are not the only things that can be located in the gaps. It also makes sense to fit the reed blades in the same gap as the non-passing threads (specifically among the warp threads), so the passing spools can move in front of them. In normal weaving this rather trivially happens, because the only passing spool—the shuttle—moves in front of the

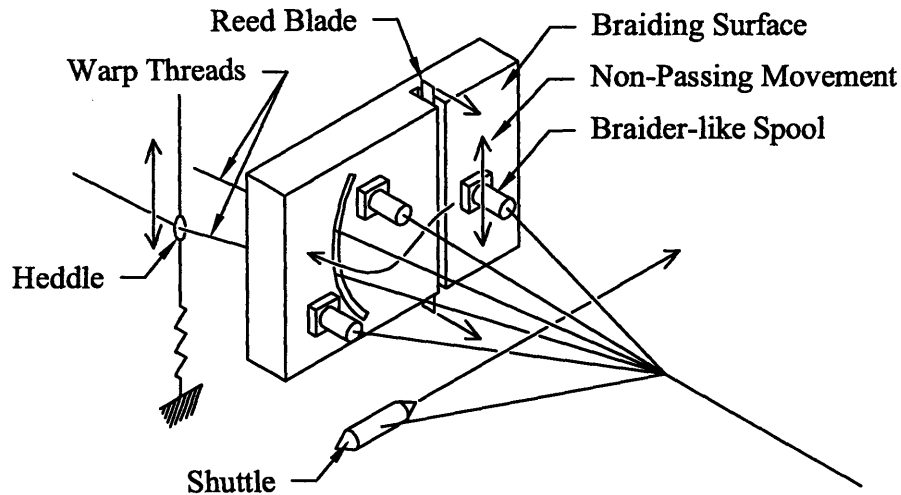

Figure 7-1: The Highest-Level New Features of the Machine

reed. I have not found prior art in which braiding-machine-like thread carriers pass in front of reed blades. Existing braiding machine beat-up mechanisms involve reed blade insertion, instead (see Section 4.4).

7.10 The Main New Features

In summary, the proposed braiding machine is characterized by at least the following new features, some of which are pictured in Figure 7-1:

- A specialized, shuttle-like thread package which passes fill yarn among the other threads—including threads coming from braider-like spools—with non-passing thread operations to choose on which side of the fill path these other threads are located.
- A braider-like thread carrier that crosses the paths of multiple warp threads at once.
- A braider-like thread carrier that crosses a warp fiber that is actuated by a heddle.
- Passing braider-like thread carriers in front of reed blades.

In practice (unlike in the picture), each of these features would occur many times on the machine. These features can be used independently, but they work well together.

Chapter 8

Abstract Bias-Package Design

Section 3.2.5 established that passable thread packages are necessary in braiding machines. Chapters 8–11 will describe the development of a bias-thread package for a bias-weaving machine. The design process is structured as follows:

1. Establish functional requirements.
2. Make the decision to use springs.
3. Enumerate the possible one-dimensional abstract spring designs.
4. Create less abstract—but still schematic—embodiments of promising designs.
 - (a) Develop ways of adapting rotary motion to linear thread motion, as is required for some of the concepts in Step 3.
 - (b) Develop embodiments of the designs in Step 3.
5. Combine promising items from 4a and 4b, to create embodiments which are detailed enough to be built.
6. From thread-feeding experiments, eliminate unworkable designs, leaving one design.
7. Revise that design for manufacture.

The design process was not entirely planned at the beginning, because some parts of the design process influence how the rest of it developed. For instance, the decision to use springs

was not built-in from the beginning, but rather it seemed like a useful and safe decision at that point.

The organization of the tensioner-design chapters follow the design process above. Steps 1–3, dealing with abstract designs, are described in this chapter. Steps 4 and 5, dealing with less-abstract designs, are described in Chapters 9 and 10, respectively. The final steps of the design process are described in Chapter 11. Section 11.4 succinctly recapitulates the the design process.

8.1 Functional Requirements

8.1.1 Thread Capacity

A large thread capacity (length of bias thread contained in the package) is desirable for two reasons. First, it means that thread ends or tie-ins occur less frequently in the weave. Secondly, it means that the refilling operations can occur less frequently in operation.

On the other hand, more thread capacity generally means a larger bias package, which directly causes the size of the machine to increase. It was determined that a capacity of about 100ft of thread would be a good balance. Test wrapping a spool by hand (moderately tight) with the Hexcel IM7G12K carbon-fiber thread indicates that approximately 1cm^3 of wrapping space holds 1m of thread.

8.1.2 Tension Control

The bias package must include a means for controlling the tension of the thread. If the tension is too low, the bias threads will vibrate excessively when the bias package moves. This could lead to tangling if, for instance, a fiber vibrates into the space through which the shuttle is passing. If the tension is too high, the thread will wear excessively during beat-up. Also, the tension will affect the final weave, causing the bias threads to be straighter or wavier according to whether the tension is high or low. Therefore, consistency, at least, is desirable. As a first cut, the design value is $30\text{g} \pm 30\%$.

The $\pm 30\%$ was chosen because it was seemed both small and achievable. 30g was chosen

using another simple experiment. A length of thread was hung with a weight on the end. The length of this thread was equal to the largest free length that would occur in the machine (from the fell to the top bias package when the column is all the way up). Then, the weighted thread end was moved back and forth with motions similar to those that would occur in the machine. 30g was the smallest tension that kept the thread satisfactorily straight.

The final tension value on the bias packages that were built is probably significantly higher.

8.1.3 Take-Up

This is, in some sense, the same tensioning requirement. As the columns move up and down, the distance from the bias package to the fell changes. Therefore, the bias package must be able to both pay-out and take-up thread. The total required to be taken-up is about 20cm.

8.1.4 Size

The bias package directly influences the size of the machine. As it grows wider, the columns must spread more or moved further from the fell. As it grows taller, the warp shed must grow, since they bias package must be able to pass through the warp shed when the bias package shifts.

Spacing between the bias packages on the column will be similar to the warp shed height. If the bias shed is smaller than the warp shed, the shuttle would either be prone to catching bias fibers, or placed farther from the fell. If the bias shed is larger than the warp shed, the columns would be unnecessarily tall, which complicates the column design and increases the amount of thread the bias package must take-up.

This specification was a compromise between the bias package and other aspects of the machine. In the end, the bias packages are required to be less than 3cm wide and 5.5cm tall. They are spaced 8cm on the column.

8.1.5 Other Requirements

The bias package design must be kept inexpensive since, 256 of them are used in the completed machine. Also, wear on the thread must be kept within acceptable limits. These requirements do not have hard specifications.

8.2 Choice to Use Springs

The tension control functional requirements could potentially be met in several ways:

Active devices, such as electrical or pneumatic systems, could be used. But they require routing power to a moving bias package—a difficult task. Electrical systems are especially intriguing on account of the potential simplicity of having a small motor constantly urge the bias package to take-up thread. In practice this is harder than it seems (Section 11.1 will discuss problems with using rotary motion to take-up and pay-out thread). The current and power dissipation of 256 stalled motors also seems problematic.

A passive system means that springs are probably necessary to provide the take-up function. They need not be springs in the metal-coil sense—though they probably will be for cost reasons—but rather any conservative mechanism that pulls back with a relatively constant force. For non-constant force springs, relatively constant force can be achieved by using sufficiently small changes in displacement, or a sufficiently small spring constant.

8.3 Tensioning Using Releasing Elements

Imagine a tensioning system consisting of a spring with one end attached to ground and the other attached to the thread. With an appropriately chosen spring, the thread can be moved in and out by the required amount, while the tension is kept within allowable limits.

However, if the thread is pulled out of the bias package continually, eventually there will come a point where the spring has been pulled too much. That is, the force is too high or the extension is problematic for some other mechanical reason. It seems that any reasonable spring has the property that it can be stretched by a limited amount.

Since the length of the bias package contents is almost certainly larger than the allowable

spring displacement (even with some transmission system), some method must be introduced to allow the spring to contract again, without releasing tension on the bias thread. This is done with a releasing element.

8.3.1 The Releasing Element

A releasing element is an idealized force member, like the spring. It, however, is rigid unless it is triggered to release. When released, the element may or may not sustain some force. In a tensioning mechanism, the releasing element will always be triggered when the spring reaches a critical displacement; the aim is to limit spring displacement to reasonable levels.

8.3.2 Ways of Using the Releasing Element

There are fundamentally three ways to connect the spring and releasing elements:

- Put the releasing element in series with the spring, with the spring connected to ground (Series 1).
- Put the releasing element in series with the spring, with the releasing element connected to ground (Series 2).
- Put the releasing element and spring in parallel.

The possible arrangements are shown in Figure 8-1. The diagrams are one-dimensional lumped-parameter idealizations of mechanical systems, with displacements as the across variable and force as the through variable.

The parallel configuration requires an adding element, in which the output displacement is the sum of the two input displacements and the forces are such that energy is conserved. Similar blocks, where the input displacements are scaled and added, will also work. A set differential gears is an example of such an element.

Each of these arrangements has the same functional behavior if the release element is triggered when the spring reaches a critical length. Under these conditions, each one allows an infinite length of tensioned thread to be payed-out, and can maintain tension while

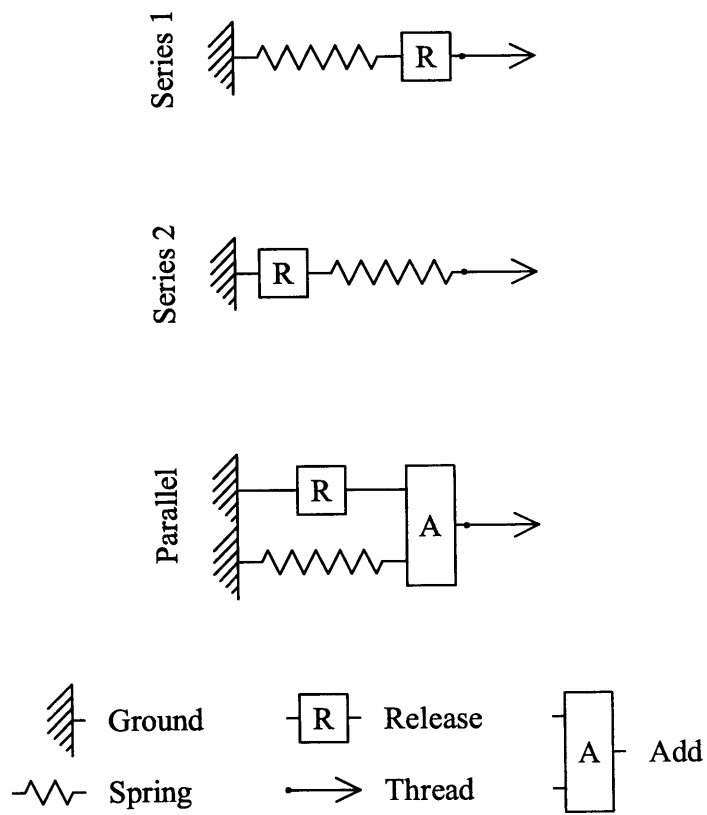

Figure 8-1: Ways of Using the Releasing Element

taking-up a finite amount of thread. These are the main functional requirements for the bias package.

One might complain that the Series 1 and Series 2 configurations are equivalent. If everything is massless, they are. Practical considerations of the mass of parts make it useful to differentiate the two. This is discussed in Section 8.5.

8.4 Types of Releasing Elements

The releasing elements must be activated at the appropriate moment. One may accomplish this in basically two ways:

- Activate when the force on the spring becomes large enough.
- Activate when the displacement on the spring becomes large enough.

These will be referred to as force- and displacement-release mechanisms, further described below. Each can be combined with any of the three ways to connect the spring and releasing element, for a total of six possible designs, as shown in Figure 8-2. Of course, since the force on the spring is related to the spring's displacement, the two approaches can ideally be made to release at the same point.

8.4.1 Force Release

The force-release element works like this: When it is subjected to a force that is below a certain limit, it allows no relative displacement across it. Otherwise it allows slip.

In the tensioning mechanism, the release should work according to the state of the spring. Since force is the through variable, the spring force can be sensed remotely. Therefore, the force-sensing and releasing aspects of the force-release element are bundled together, conceptually and in Figure 8-2.

Clearly, the force-release element could be approximately embodied by a friction connection. While the applied force is below the static friction limit, it stays rigid. When the force is raised to the static friction limit, it slips. Here, it sustains some different force while slipping: the force provided by the kinetic friction.

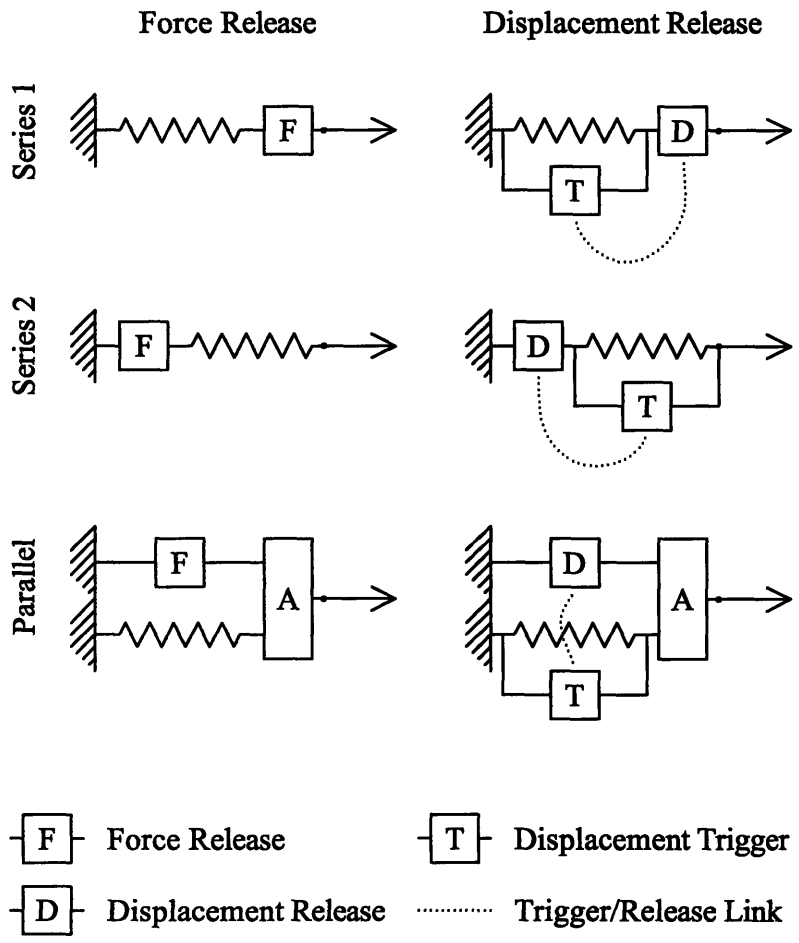

Figure 8-2: The Possible Abstract Tensioning Mechanisms

One might also note—as an example of how these functional blocks could be made by connecting other functional blocks—that an entire tensioning mechanism could also be used as a force-release block.

8.4.2 Displacement Release

The displacement-release element works somewhat differently. It requires a displacement trigger located elsewhere. When the displacement across the displacement trigger is less than some limit, the displacement release acts like a rigid link. Otherwise it allows slip. Ideally, no force is sustained by the displacement trigger, it is solely a measuring device.

In the cases of interest to tensioning, the displacement trigger is always in parallel with the spring, since it is the spring's displacement that needs to be limited. The trigger and releasing functions must be separated because the displacement of the spring cannot be sensed remotely at the displacement release, in contrast to the force release.

Displacement Following

In Series 2 displacement release mechanisms, the displacement of an input that is nearly force-free (the side of displacement trigger that meets the thread) is used to control the displacement of an output (the ungrounded side of the displacement release) that has force being exerted on it. It does this in such such a way that the forced output follows the displacement of the force-free input, at least under pay-out conditions. It is similar to using a capstan to control the descent of a heavy object. With enough wraps, the displacement of the load end of the rope follows the displacement of the controlling end with very little force applied. Concrete examples of this in the design of tensioners are given in Sections 9.2.2 and 9.2.3.

8.5 Dynamic Response: Eliminating Series 1

The idealized tensioning mechanisms capture only the most basic aspects of the tensioner operation. In fact, under certain conditions, the configurations are not even well defined. For instance, suppose that in the Series 1, force-release device, the force-release mechanism

sustains no force when slipping. In that case, if the spring is pulled enough to cause the force-release mechanism to slip, the system will not be well defined, since the spring has a displacement, but cannot be providing any force.

The mass of actual parts will resolve this problem, because the unbalanced force at the spring-release connection will cause something to accelerate. The dynamic aspect of things is not captured in these models. Nor does it need to be for the models to be useful.

In order to capture the basic dynamic properties of the designs, the following experiment may be made: Assume that there is a mass at every connection between elements. Furthermore, assume the release mechanism sustains zero force or reduced force as it slips. These are accurate assumptions; there will be mass in reality, and most conceivable release mechanism will offer reduced force while releasing. Under these conditions, which of the three mechanisms maintains constant tension?

In the Series 2 or Parallel configurations, the dynamic force from the acceleration of the mass at the output of the release provides the necessary balancing force to the spring, so tension is maintained. In Series 1, however, the mass between the spring and the release accelerates towards ground. The connection with the string, unmoved, suddenly has no force on it, and tension in the thread drops. Series 1 designs can be eliminated on this basis.

One advantage that Series 1 displacement-release mechanisms have over the Series 2 displacement-release mechanisms is that the displacement is measured between a moving part and ground, not between two moving parts. Often, this is easier. It shares this property with the parallel displacement-release mechanisms. Perhaps Series 1 designs that more gradually allow slip could be made to work.

Chapter 9

Tensioner Design, Round 1

Bias package development continues in this chapter, with the development of several designs. These designs are less-abstract embodiments of the mechanisms shown in Figure 8-2. Their development is essentially a creative exercise.

In certain cases, the mechanisms will be separated into two functional pieces: a mechanism to convert rotary displacements to string displacements (Section 9.1), and a mechanism that has the required force-displacement properties in rotary form (some designs in Section 9.2). The two functional submechanisms can be mixed-and-matched. For this reason, the rotary-tensioning mechanisms will not be shown coupled to any particular mechanism for adapting rotary displacements to thread displacements.

A note on the diagrams: unless otherwise noted, cut-away pieces may turn freely on their axles.

9.1 Rotary Displacements to Thread Displacements

While designing a rotary system may be desirable for a number of reasons—including the jamming problems of many linear systems—there is a more fundamental reason why it is necessary in some cases.

Consider a linear interpretation of the Series 2 designs in Figure 8-1. As the full 100ft of thread is payed-out, the spring also also moves by approximately 100ft. In a very practical sense, parts of the bias package cannot move by 100ft. In the parallel configuration, the

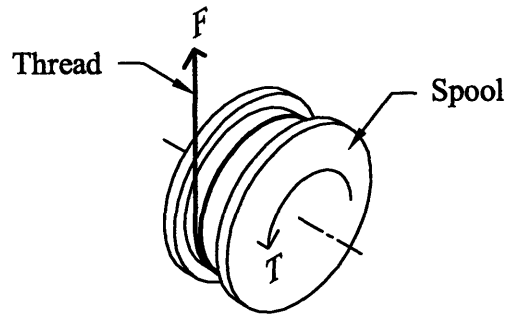

Figure 9-1: The Restrained Spool

ungrounded end of the release mechanism has the same problem. This problem can be cleverly dodged in some cases by incorporating the thread itself into the mechanism (see Section 9.2.5), but this cannot always be done.

The problem can also be resolved by using a rotating mechanism, whereby the mechanism can undergo infinite (angular) displacements, but still does not violate any packaging requirements. This rotary motion has to be somehow converted into the linear motion of the string, however.

Several possible rotary-to-linear concepts are described below. In every case, the tension in the the string, F , is counteracted by the torque, T , coming from the rotary mechanism that embodies one of the abstract tensioning designs.

9.1.1 Restrained Spool

The most straightforward design, shown in Figure 9-1, is the restrained-spool concept. In this concept, the thread's spool is rotationally restrained by the tensioning mechanism. This provides a positive connection between the angular position of the spool and the pay-out of the fiber. But the torque may need to change as the spool empties.

9.1.2 Squeeze Roller with Guides

The next concept is the "squeeze roller with guides" concept, shown in Figure 9-2. In this case, the thread is squeezed between the torque roller to which the rotary tensioning

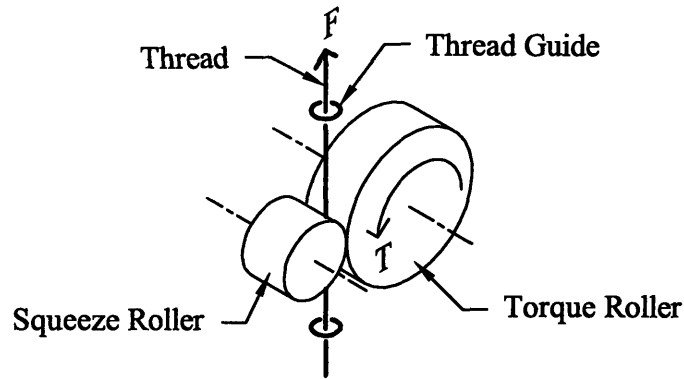

Figure 9-2: Squeeze Roller with Guides

mechanism is attached, and a free-turning squeeze roller. Friction provides the connection between the angular displacement of the torque roller and the linear displacement of the thread. The thread on one side of the mechanism is slack.

Guides are necessary to guarantee that the thread does not walk, as it is payed-out or taken-in, to one side of the rollers, because this would allow the thread to escape from the grip of the mechanism. The guides ensure that the thread feeds into the rollers near the center. That is, as the thread is pulled upward in Figure 9-2, the bottom guide ensures that the slack thread gets gripped near the center of the rollers. When the thread is moving downward, the top guide is ensuring proper entry of the tensioned thread.

9.1.3 Squeeze with Shaped Roller

The third concept, “squeeze with shaped roller”, works in a very similar way, except the guiding is accomplished by the shape of the rollers. This is shown in Figure 9-3. By fitting the squeeze roller in a groove in the torque roller, the thread is captured. The thread cannot easily fit between the walls of the two rollers to escape.

9.1.4 Variations on the Squeeze Roller

Several variations of the squeeze-roller concepts may be used. These are shown in Figure 9-4. Each variation increases the wrap angle on the torque roller. The motivation for doing this

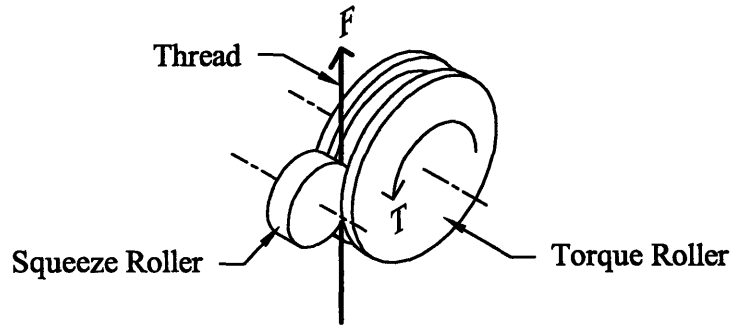

Figure 9-3: Squeeze with Shaped Roller

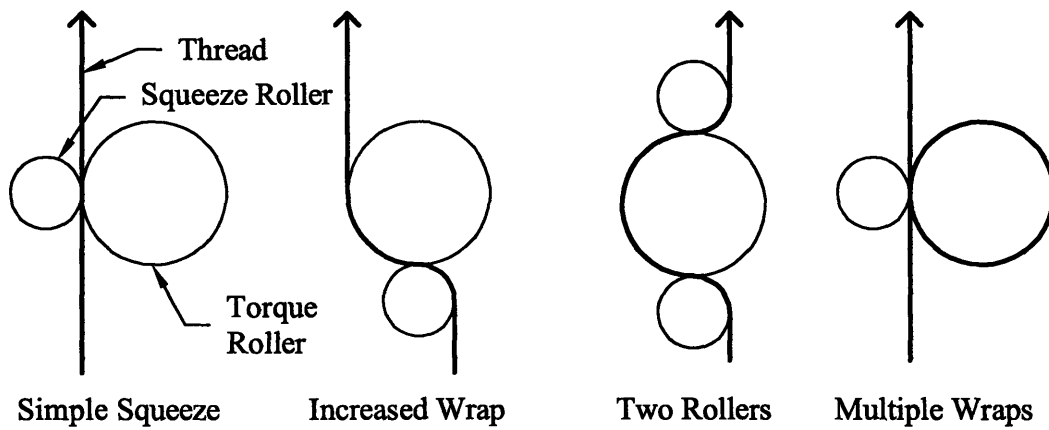

Figure 9-4: Variations on the Squeeze Roller

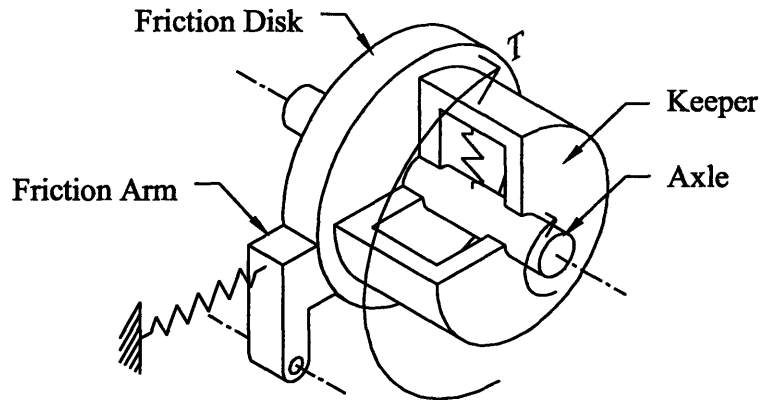

Figure 9-5: Force-Release Using Friction

is that the squeezing preload may be reduced by taking advantage of capstan effects. One suspects that this causes less damage to the thread, and less hysteresis in the mechanism. Increased wrap angle may be formed by relocating the squeeze roller, adding a second roller, wrapping multiple times, or some combination of these.

9.2 Tensioner Designs

9.2.1 Design 1: Force Release Using Friction

As previously stated, friction is a natural embodiment of the force-release element. A design incorporating a friction element for this purpose is shown in Figure 9-5. A clock spring or other large-travel torsional spring is connected between the spring keeper and the axle. The keeper is the output of the mechanism, and would be attached to a device which adapts rotary displacements to thread displacements. This adapting device, in turn, provides the indicated torque on the keeper. Friction between the friction arm and friction disk (attached to the axle) connects the spring to ground. This is an embodiment of a Series 2, force-based mechanism from Figure 8-2.

The main advantage to this design is its simplicity. However, it relies on the force of friction, which may be unreliable in the presence of oil and thread dust. The difference between static and kinetic friction will also cause tension variations. As the the friction disk

slips, it will oscillate about the displacement that causes the spring tension to equal the kinetic friction. It will stick after half a cycle. Therefore, the tension will vary by twice the difference between kinetic and static friction.

There may also be a problem in finding a suitable spring. While clocksprings do have large travel and low spring rate, rubbing coils tend to cause large hysteresis and unpredictable behavior [25].

9.2.2 Design 2: Displacement Release Using Friction

Figure 9-6 shows a mechanism that uses friction in a Series 2, displacement-release mechanism. Again, the keeper is the output, but this time it is sprung to the inner sleeve, which is free to rotate on a fixed axle. A release spring, whose free inner diameter is slightly smaller than the axle diameter, grips the axle by friction (as in a spring clutch), grounding the inner sleeve. A small force lifting the other end of the spring caused it to slip, ungrounding the inner sleeve.

As the thread is pulled out, the keeper can be rotated relative to the sleeve by just under two rotations. After that, the pin on the keeper hits the protrusion on the intermediate disk, forcing it to turn. The pin on the intermediate disk lifts the end of the release spring, causing it to release its grip of the axle. This means the sleeve is free to follow the keeper, limiting the stretch on the spring, as is required. If the thread reverses direction, the keeper can rotate relative to the sleeve by about two rotations, to take-up thread.

The intermediate disk was introduced so that (just under) two rotations the keeper happen before the pin is forced to hit the release spring. In other words, two rotations of take-up can occur. If one rotation was sufficient, the intermediate disk could be eliminated. Practically, given packagable sizes of any torque roller, two rotations are probably necessary. Additional rotations would require additional intermediate disks. A gear ratio between this mechanism and the mechanism to convert rotary displacements to thread displacements could also be used, but it may be more difficult to package.

This design suffers from being enclosed. If something were to go wrong, it would be difficult to troubleshoot. Setting the initial preload may be difficult, as well.

The release spring is an example of the input-output follower described in Section 8.4.2.

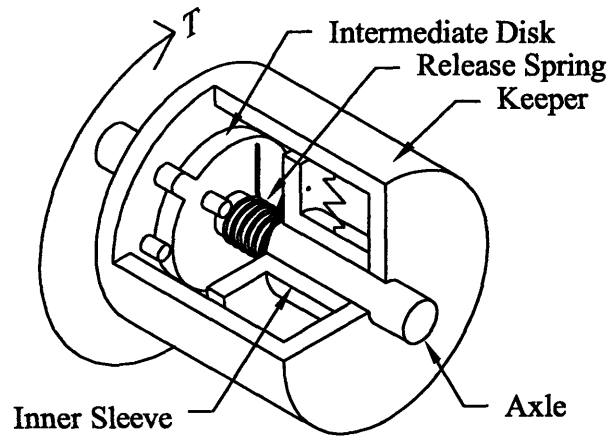

Figure 9-6: Displacement-Release Using Friction

The end of the release spring which is being pulled by the inner sleeve—the forced output—follows the displacement of the other end of the spring—the force-free input. In fact, this design even uses the capstan principle. The fact that a negligible force can unground the release spring means that little additional torque is required for that operation.

9.2.3 Design 3: Displacement Release Using an Escapement

Figure 9-7 shows a Series 2, displacement-release mechanism using an escapement. Again, the spring keeper is the output of the mechanism. The spring runs between the keeper and the axle, which is attached to the catch disk. The escapement arm is constrained to move only vertically.

This mechanism keeps the spring preloaded to within a half turn of its initial preload. As shown, the catch disk grounds the axle (and thus one end of the spring) through catch *A*. This does not change unless the keeper is rotated far enough clockwise that the lift wedge (attached to the keeper) lifts catch *A*. If this happens, the catch disk will rotate and be caught by catch *B*, reducing the preload on the spring by half a turn. From that position the keeper can be rotated (just under) half a turn in either direction without causing any changes. By this method, the spring preload is kept within half a turn of the preload that occurs when a catch is lifting. The keeper can always rotate counterclockwise by half a turn to take-up thread.

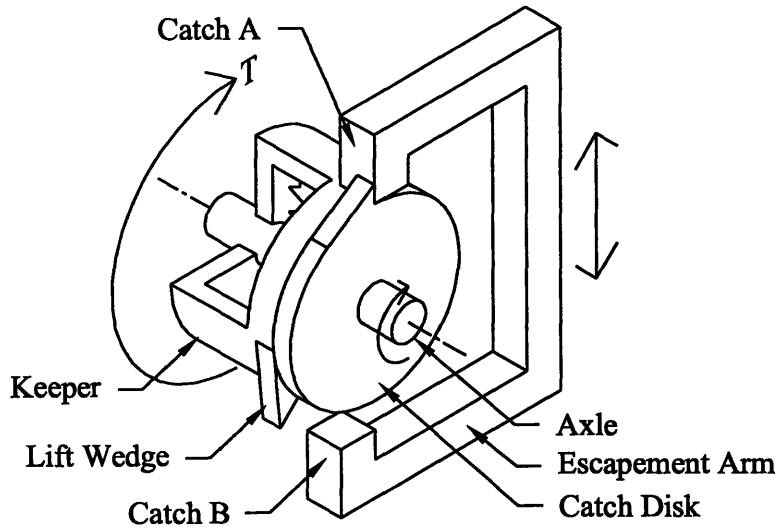

Figure 9-7: Displacement-Release Using an Escapement

The problem with this mechanism is that, as with the mechanism in Section 9.2.2, multiple rotations of take-up would be necessary to make it practical. Something like an intermediate disk might be introduced. The linear movement of the escapement arm may also cause jamming difficulties.

This is another example of the input-output follower described in Section 8.4.2. The motion is somewhat discretized, though. Ideally, the lift wedge causes negligible torque on the keeper, so the input is unforced.

9.2.4 Design 4: Rotary Parallel Displacement-Release

Figure 9-8 shows a design that uses a planetary gearset to perform the adding operation required for the parallel arrangement of the spring and release mechanism. In this case, axle *B* is grounded. Rotating the output roller winds the spring between the keeper and axle *B*. Eventually, the keeper rotates enough that the lift wedge lifts the friction arm, ungrounding the ring gear. This allows the keeper to rotate—even if the output roller is not moving back—to limit the spring displacement. The keeper may turn one rotation back from the release point, meaning that the output roller can turn more than one rotation when it takes-up thread.

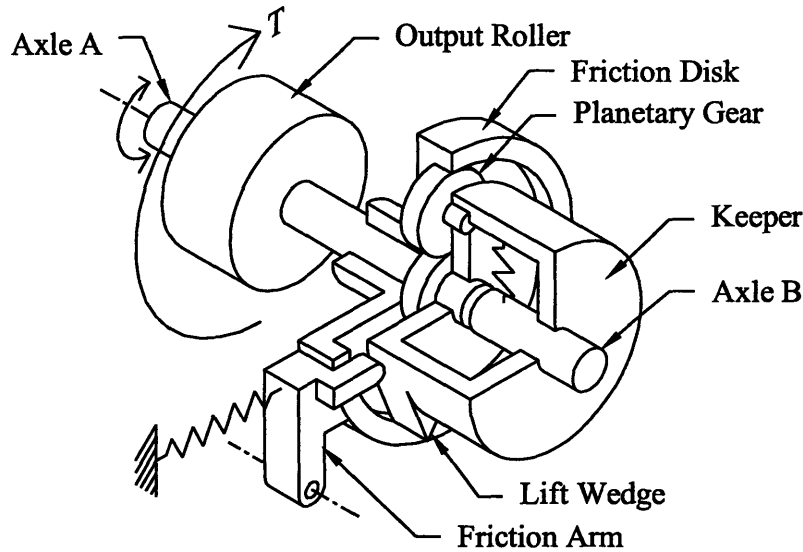

Figure 9-8: A Parallel Displacement-Release Design

While this is a complicated system, it does have some concrete advantages. The adding mechanism has allowed the displacement of the spring to be measured between ground and a moving part, rather than between two moving parts. This simplifies the design of the release mechanism. The planetary gear naturally eliminates the need for an intermediate disk by using the mechanical advantage between the output and the keeper. Lastly, setting the desired tension is particularly easy on this design. Axle *B* could be temporarily ungrounded, rotated to preload the spring to the desired torque, and then locked in place.

9.2.5 Design 5: Linear Parallel Displacement-Release

Another parallel mechanism—one that does not use a differential gearset—is shown in Figure 9-9. It is a system that does not require the use of a rotary-to-linear converter. As stated in Section 9.1, this is done by incorporating the thread itself into the mechanism: the thread forms the output of both the release element and the output of the adding element.

In this mechanism, the friction arm and squeeze roller ground one end of the sprung thread loop until the pulley starts to lift the friction arm. Then, new thread feeds into the mechanism, limiting the spring displacement. When thread is taken-up, the pulley moves down again. This mechanism is fairly simple, and uses mechanical advantage to the benefit

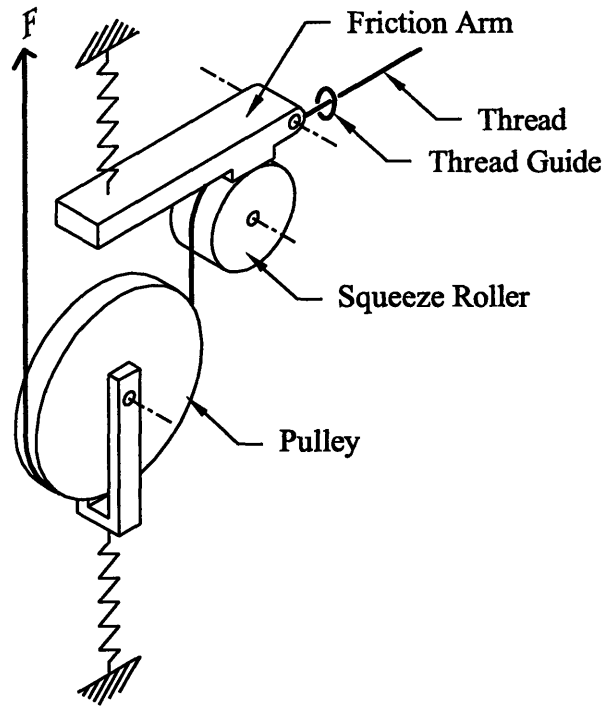

Figure 9-9: Another Parallel Displacement-Release Design

of take-up in the same way as the previous parallel design.

9.3 Friction-Insensitive Force Release

If the pulley in Figure 9-9 were affixed to the friction arm and the rolling elements were removed, one would have a mechanism such as in Figure 9-10. This is the thread tensioning mechanism as specialized for cases where thread take-up is not required. It releases thread according to force, but in a way that is independent of the coefficient of friction.

The thread is squeezed between the lever and the a stationary stop by a spring. The thread exits at the end of the lever, more-or-less perpendicular to the lever arm. When the applied force on the thread becomes sufficiently large, the lever will cease to squeeze the thread. The mechanical advantage between the applied tension and the squeezing normal force desensitizes the mechanism to the coefficient of friction. Essentially, the thread tension is compared to the spring force. If it is greater, thread releases.

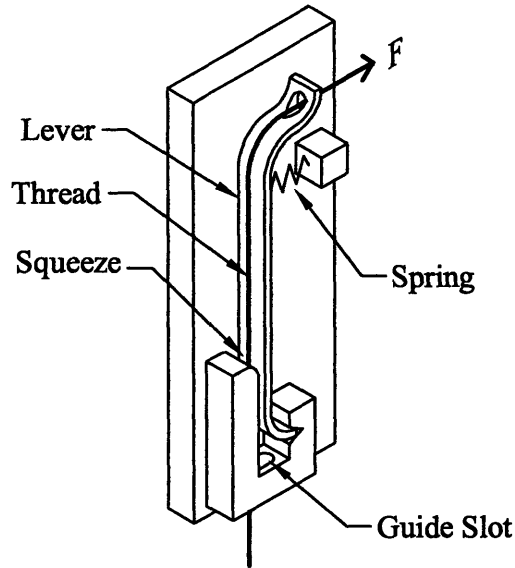

Figure 9-10: Friction-Insensitive Force Release

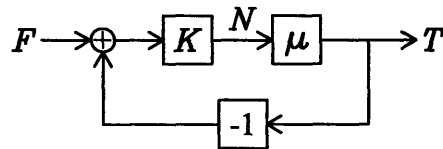

Figure 9-11: Mechanism as Mechanical Feedback System

Its operation while thread is releasing is also interesting, because it provides a well-regulated force. Under pay-out conditions, the mechanism can be represented by the block diagram in Figure 9-11. The tension in the thread, T , is equal to the squeezing force, N , multiplied by the coefficient of friction, μ . The squeezing force is proportional to the difference between the thread tension, T , and the spring force, F . The constant of proportionality, K , is the mechanical advantage between the end of the lever, and the squeezing location. A little algebra shows that

$$T = \frac{F}{1 + \frac{1}{K\mu}}$$

This shows that if K is large enough, the tension will be very near the spring force, even with variations in the coefficient of friction. It is a mechanical feedback mechanism.

The transformation from a displacement-release mechanism (Figure 9-9) to a force-release

mechanism (Figure 9-10) may seem somewhat odd. Actually, many displacement-release mechanisms behave like force-release mechanisms under pay-out conditions. Furthermore, friction-based displacement-release mechanisms (including the final tensioner) often exhibit this very same kind of mechanical feedback during pay-out conditions. Tensioners with discrete-release mechanisms such as escapements do not exhibit this particular mode of operation, but can still produce well regulated output in cases where the spring isolates the string tension from the release tension by dynamics, according the discussion in Section 8.5.

Chapter 10

Tensioner Design, Round 2

This chapter will describe fleshed-out versions of the more promising mechanisms from Chapter 9. Each of the rotary concepts includes both the tensioning mechanism and the mechanism to convert rotary to linear motion. In the pictures, they will be shown approximately actual size unless otherwise noted. But first, ways of paying-out thread from the storage spools must be discussed.

10.1 Spool Styles and Pay-off Methods

Spools may have two, one, or no flanges on the ends, and be payed-off to the side or over the end, as shown in Figure 10-1

The function of the flanges is to provide stability to the thread at the ends of the spool. If the thread was wound straight (perpendicular to the spool axis) and the flanges were not there, it would collapse in a tangle at the ends. This can be overcome by tapering the winding near the ends, or cross-winding the spool.¹

The thread may be removed from the spool in two ways. It can always be pulled off radially (circumferentially, actually), by allowing the spool to rotate. If the spool is cantilevered from one end and there is not a flange on the other, the thread can be removed axially.

¹Cross-winding also has the advantage of preventing “ringers”. These are stray fibers that form a circular tangle around the spool, and eventually jam the pay-off. Twist in the threads on the spool also prevents this.

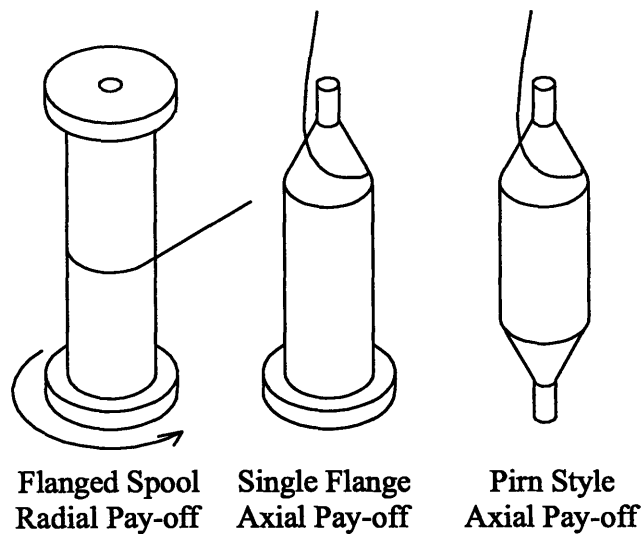

Figure 10-1: Some Spool Styles and Pay-off Methods

In this case the spool does not rotate, which reduces inertial loads, making it suitable for high-speed intermittent motion. Generally, spools that pay off axially are wound in conical layers moving towards the pay-off end. This ensures that the thread being removed is not rubbing unnecessarily against the thread still on the spool. Some restraint on thread must be provided to keep it from unwinding when it is not supposed to. When used in shuttles, for example, the cavity in which the spool sits is sometimes lined with fur for this purpose. [20]

10.2 Tensioner Designs

10.2.1 Design 6: Force Release, Restrained Spool

Since the restrained spool seems like the simplest method of adapting a rotary tensioning mechanism to the thread (see Figure 9-1), and the friction-based force-release mechanism (Figure 9-5) seems like the simplest tensioning mechanism, it makes sense to try to combine the two. Unfortunately, as the spool unwinds, its changing radius means that different torques must be applied to the spool to maintain constant tension. This can be overcome, but it requires some extra mechanism, as shown in Figures 10-2 and 10-3.

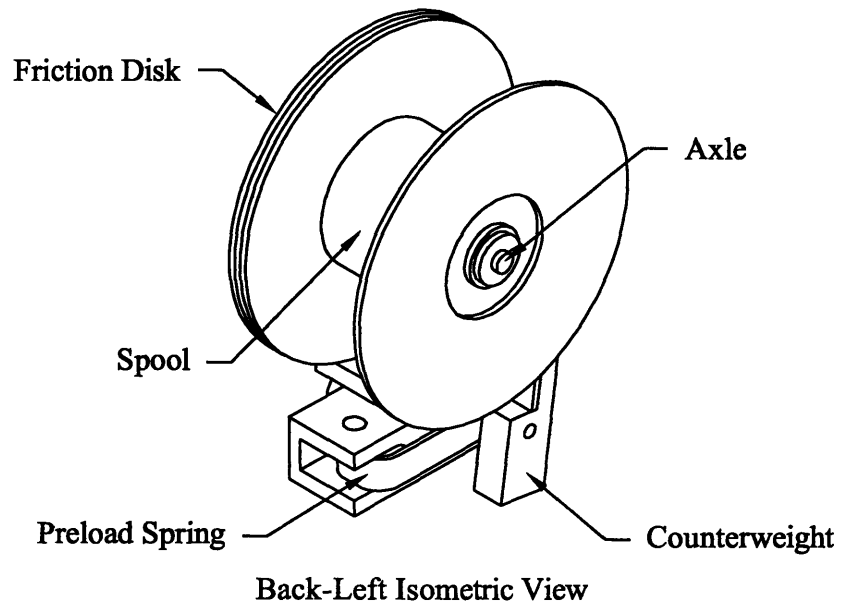
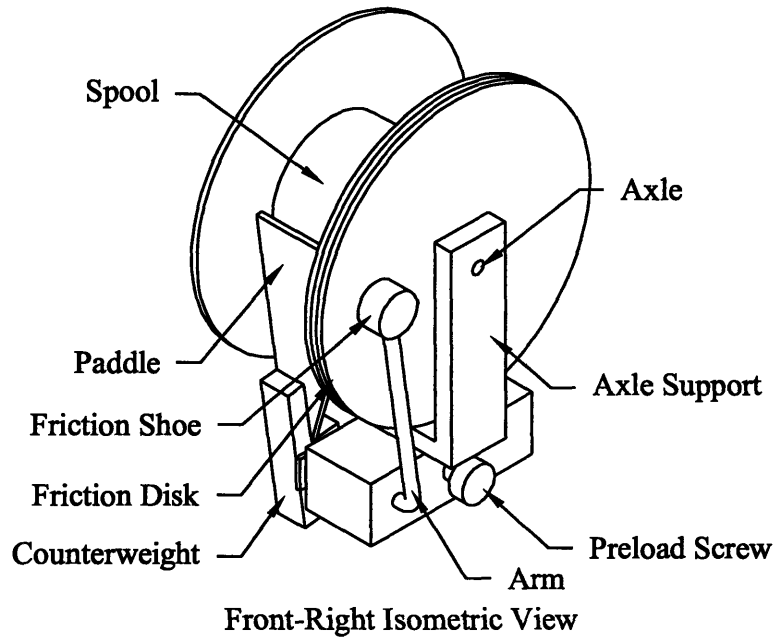

Figure 10-2: Bias Package 1: Isometric Views

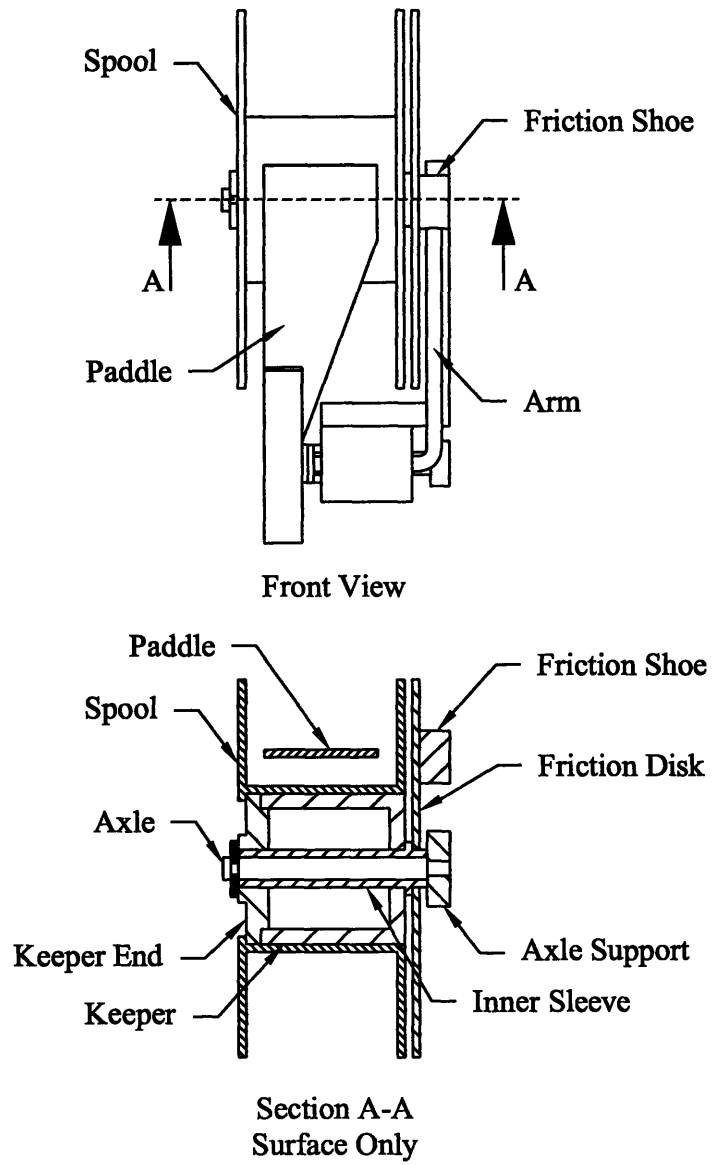

Figure 10-3: Bias Package 1: Section View

This mechanism has two rotating pieces: the inner sleeve and the friction disk, connected together; and the keeper and the spool, connected but separable for changing spools. The spring connects these two subassemblies. The inner sleeve rotates on a stationary cantilevered axle. The axle is cantilevered so that the spool can be easily removed (pulled off to the left in Figure 10-3). A stationary axle and inner sleeve was used because the large overhang would cause binding problems in the bearings of a rotating shaft.

Unlike previous examples, the friction disk is preloaded axially instead of radially. This allows it to be coupled with the paddle that lightly rubs against the thread as it unwinds. The result is that the friction shoe is kept at approximately the same radius as the thread, changing the applied torque in the desired fashion. Some means would have to be provided to maintain contact between the thread and paddle. A counterweight is shown so that linear acceleration will not affect the preload.

In shuttles, a friction drag is sometimes applied directly to the surface of the wound thread. Like in the mechanism above, this results in the friction force being located at the same radius as the thread, so as to provide the required changing torque. Unfortunately, that approach cannot be applied to this tensioning mechanism because of the take-up requirement.

10.2.2 Design 7: Force Release, Squeeze Roller

Avoiding the changing-radius complication in the previous design implies that one of the other rotary adapters should be used. Figures 10-4 and 10-5 show a bias package using a squeeze roller, but still with the friction-based force release. The mechanism is essentially the one shown in Figure 9-5. The spring preload can be adjusted via a screw.

The spool is not shown, but would either be an axial or unconstrained radial payoff spool. As shown in Figure 10-4, the mechanism can be split open for easy loading. When closed, the two half-guides surround the thread to form a guide. The other thread guide is omitted in the hope that the torque roller is wide enough that the thread cannot walk to the edge during take-up.

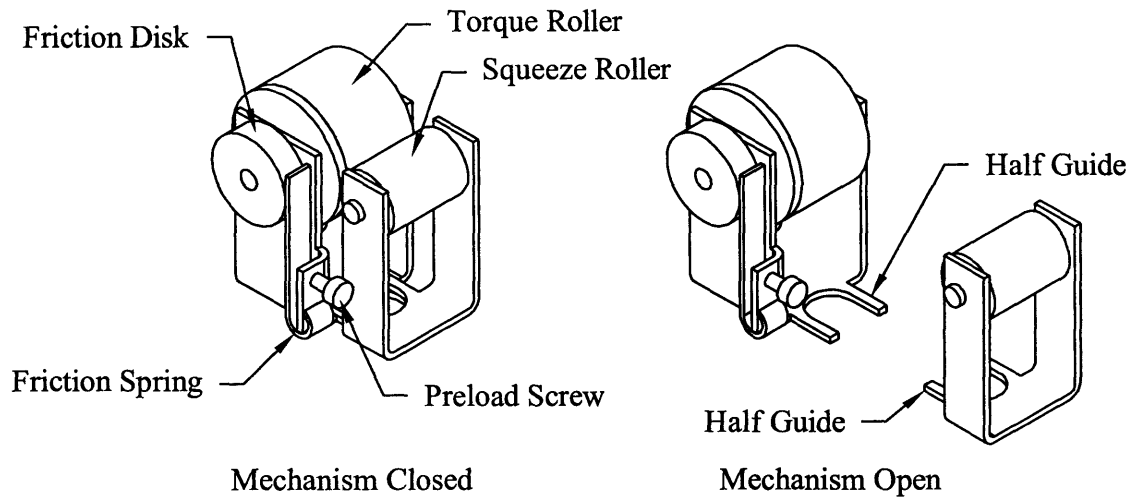

Figure 10-4: Bias Package 2: Isometric Views

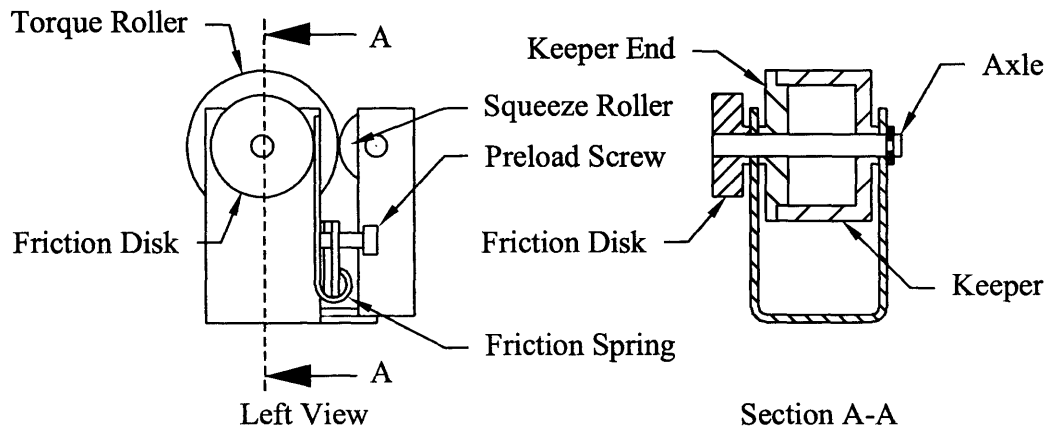

Figure 10-5: Bias Package 2: Section Views

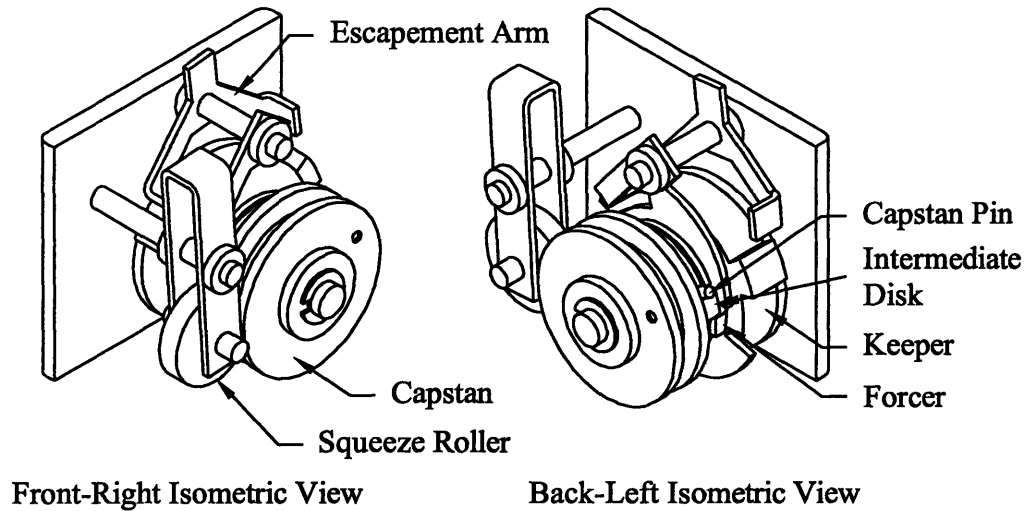

Figure 10-6: Bias Package 3: Isometric Views

10.2.3 Design 8: Displacement Release, Shaped Squeeze

The escapement design shown in Figure 9-7 suffered from linear motion and only a half rotation of take-up. These shortcomings can be addressed by using a different type of escapement. This mechanism, combined with a shaped roller to convert the rotary motion to thread motion, is shown in Figures 10-6, 10-8, and 10-7. The squeeze roller must be preloaded against the shaped roller by a spring (not shown).

Like the design in Figure 9-6, this design also uses an intermediate disk to increase the number of take-up rotations. The intermediate disk is a sheet metal disk with a bent tab. A pin on the capstan can catch the intermediate disk's tab, and the intermediate disk's tab can catch a similar tab on the forcing disk. The tab on the forcer disk is not long enough to directly reach the capstan pin.

This escapement works slightly differently than the escapement shown in Figure 9-7. It has one catch instead of two, and three lift wedges instead of one. Its operation, shown in Figure 10-8, goes like this:

1. The stop arm normally holds the stop attached to the spring keeper.
2. When the capstan has turned sufficiently far that the capstan pin contacts the intermediate disk tab, and the intermediate disk tab contacts the forcer tab, it begins to

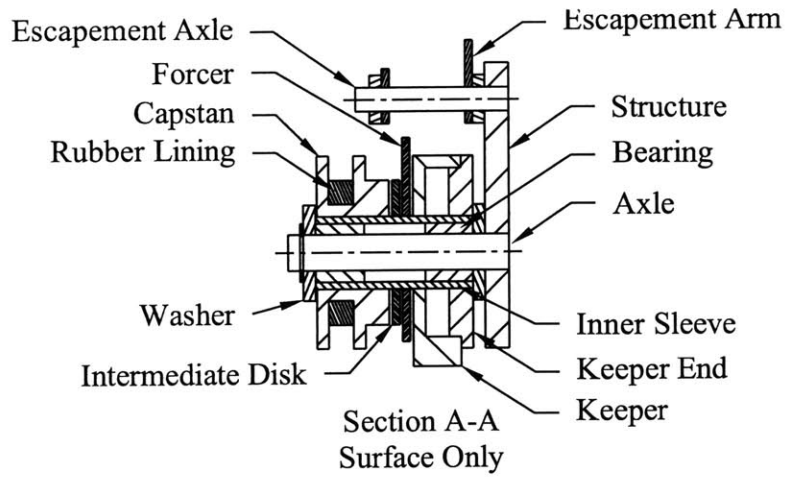

Figure 10-7: Bias Package 3: Section View

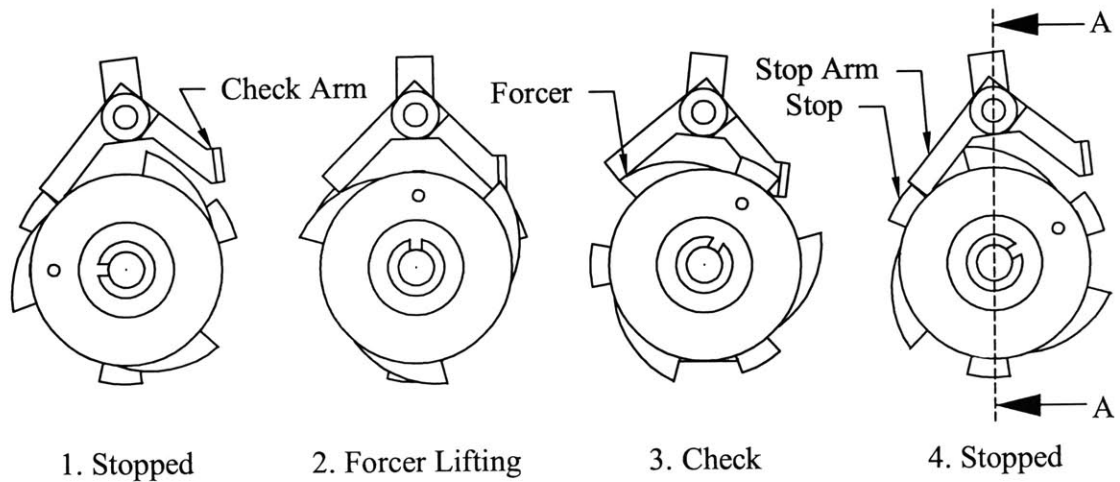

Figure 10-8: Bias Package 3: Escapement Operation

turn the forcer. The forcer begins to lift the stop arm.

3. The capstan continues to turn. The forcer lifts the stop arm enough to release the stop. The main spring moves the keeper forward (clockwise, in the view), and it is stopped by the check arm.
4. The angled check arm forces the escapement arms counterclockwise, so that the next stop on the keeper is caught by the stop arm. The geometry of the arms is such that releasing the stop from the check arm ensures that the stop arm is already in place to catch the next stop. This returns the state of the mechanism to that of step 1.

In this design, the tensioner is connected to an axial pay-off spool, as shown in Figure 10-7. Usability is a concern; the spool should be fairly easy to load. One specification might be that threading the string through holes should not be required. Loading the bias package is envisioned like this:

1. The bias package is opened.
2. A full bias spool is placed in the opened bias package.
3. The bias package is closed.
4. The thread is introduced into the bristle ring, which prevents unwanted thread pay-off.
5. The squeeze roller is lifted off the shaped roller, and the thread is put in between.

Several aspects of the design aid this process. First, the opening bias package assures that the user does not need to reach into a tight space to insert the spool. Secondly, the bristle ring is not closed, so the thread can be introduced without using the thread end. Thirdly, the tensioning assembly is cantilevered from one wall to keep the mechanism as exposed as possible.

Escapement Problems

The tensioning end of this mechanism was built, exposing two design problems.

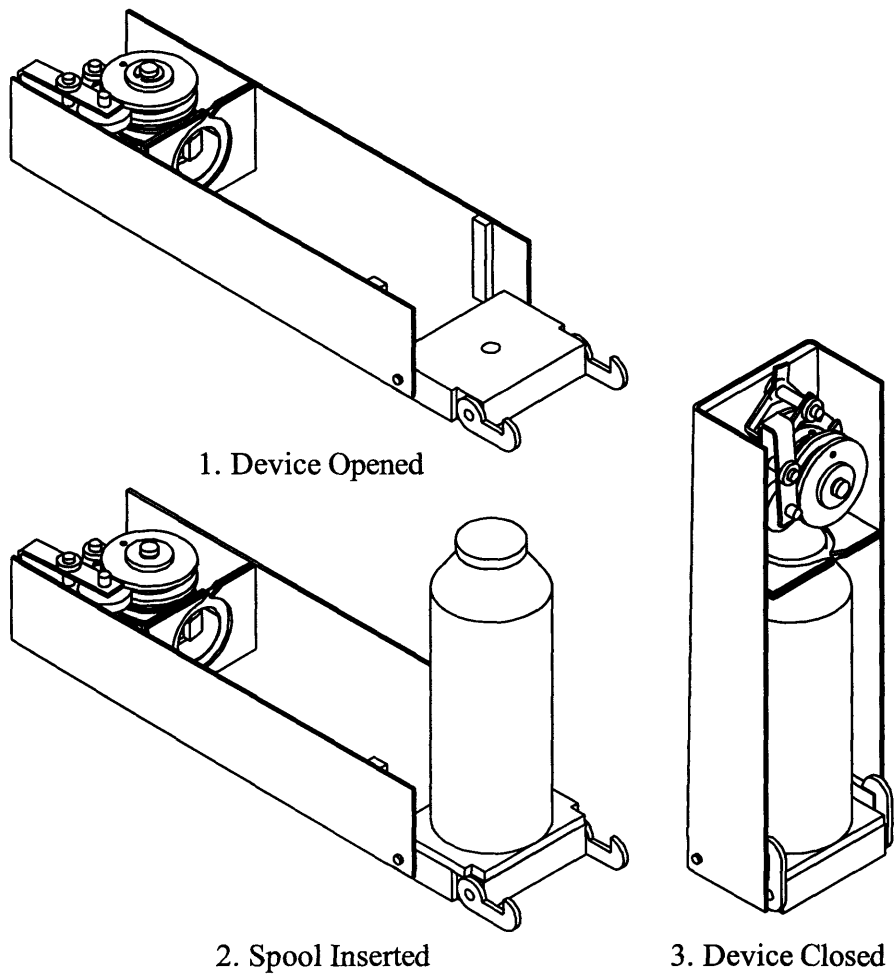

Figure 10-9: Bias Package 3: Spool Loading, Not Actual Size

The first problem happens at Step 3 in Figure 10-8. In order to ensure that the stop is released from the stop arm, the forcer needs to be slightly taller than the stop. This means that the stop arm will still be resting on the forcer when the stop hits the check arm. In this configuration, the mechanism is prone to jamming because turning the forcer further (clockwise) pushes the check arm down. The keeper must move backwards against the spring for this to happen, but this is prevented by friction between check arm and the stop. One might be able to resolve this problem by reducing the angle on the catch arm, but there is a risk here, too. That change would reduce the tendency for the check arm to slide off the stop and move to the stopped configuration (Step 4).

The second problem happens if the forcer disk moves clockwise enough to release the stop, then counterclockwise enough to release the check. This means there is a loss in spring preload as the keeper advances without a corresponding advance in the capstan. If this happens repeatedly, the spring could be entirely unwound. Note that there is nothing that could positively drive the forcer counterclockwise, but it may be driven by friction as the capstan turns counterclockwise. The solution is some mechanism that prevents the forcer from moving backwards.

10.2.4 Design 9: Displacement Release, Nonrotational

A more developed version of the mechanism shown in Figure 9-9 is shown in Figure 10-10. Some changes:

- A unconstrained radial-payoff spool is integrated into the design.
- The friction arm, friction arm hinge, and friction arm spring have been combined into one flexure.
- A release pin is used so that the pulleys do not rub directly on the friction arm.
- Two sprung thread loops are used, so that 5cm of pulley travel will produce 20cm of take-up.
- Pulleys are on cantilevered axles, so that loading a spool does not require the thread end.

- The pulleys partially surround the structure to contain their movement.

The linear motion is not a problem for three reasons: Large clearances can be used because the accuracy of linear motion is not critical. Secondly, the sideways loads are very light, because they are only caused by vibration. Finally, the floating pulleys and structure can be easily shaped to avoid jamming.

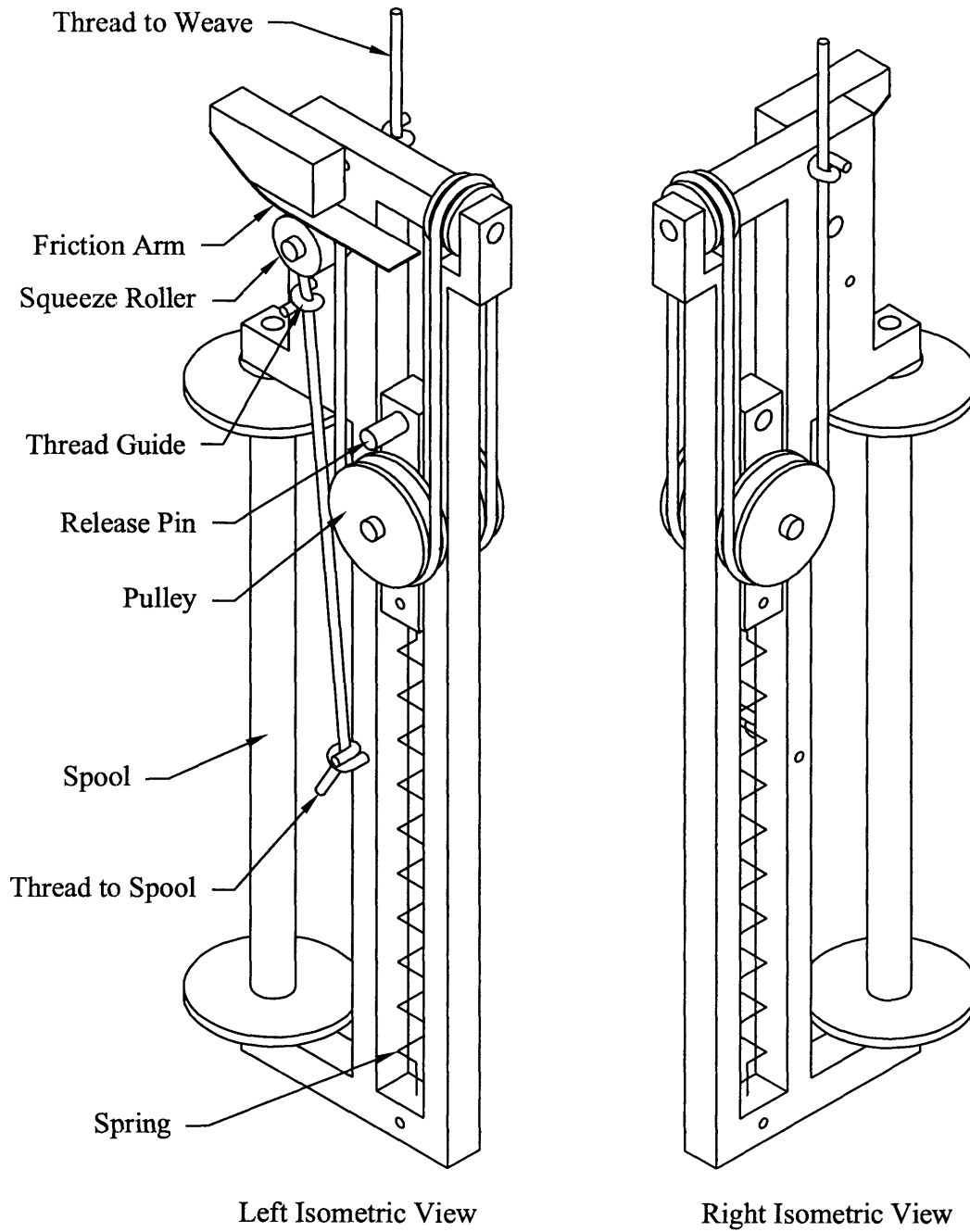

Figure 10-10: Bias Package 4: Isometric Views

Chapter 11

Final Tensioner Design, Comparisons

The final bias package design is chosen and revised in this chapter. The choice dictated by experimentally discovered difficulties with the mechanisms for adapting rotary displacements to thread displacements. The revision takes advantage of the possibility of using a restrained spool in a displacement-release tensioner, as well as various design-for-manufacture considerations. A summary of the design process and comparisons with prior art are given.

11.1 Problems with Slack Thread

All of the friction-roller thread handling mechanisms have the basic problem that any taken-up thread is not stored in an organized fashion. This is a result of the fact that the thread is slack on one side of the roller. It will always be prone to randomly getting caught in some portion of the mechanism.

Mock-ups of the friction-roller mechanisms were built. This uncovered other problems related to the troublesome behavior of slack threads. These problems are described below.

11.1.1 Guiding

As discussed previously, flat squeeze rollers require thread guides on both sides of the rollers. One guide (bottom, in the Figure) ensures that the thread is fed through the middle of the rollers when the thread is paying-out. The other (top, in the Figure) ensures that the thread

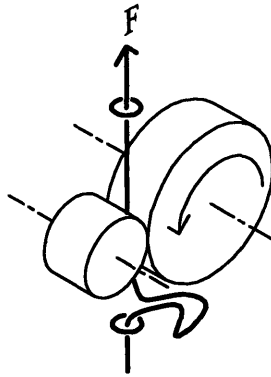

Figure 11-1: Problems with Guiding Slack Threads

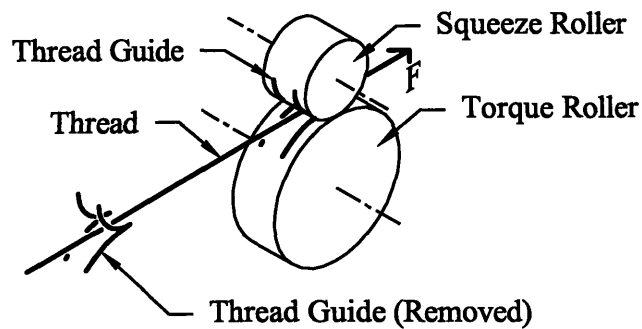

Figure 11-2: Close Guide

is fed through the middle of the rollers when the thread is being taken-up.

Unfortunately, as the thread is being take-up, slack thread is being *pushed* through the bottom thread guide. This often does not work properly. Instead of being pushed through the guide, the thread will often feed to either side of the guide, as shown in Figure 11-1. This is not a problem in itself, but becomes a problem when the thread is payed-out again, since the the thread that is did not feed through the guide is now unguided, and is not guaranteed to enter the rollers in the center. It is likely to escape the squeeze rollers entirely.

One possible way of addressing this problem is to put the thread guide very close to the rollers, as shown in Figure 11-2, so that a very small length of slack thread is being pushed. Experimentally, however, it still remained a problem.

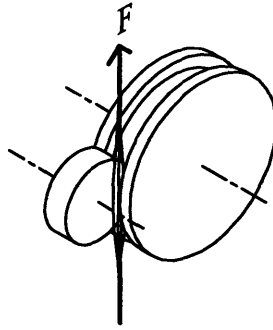

Figure 11-3: Problems with Shaped Rollers

11.1.2 Shaped Rollers

The idea behind the shaped roller was that the two rollers fit into each other tight enough that the thread cannot escape. Due to manufacturing uncertainties, however, the squeeze roller will always be undersized. Since the fibers of the thread are very small, some fibers can creep in between the rollers. This results in some of the thread fibers feeding between the rollers and some not, which shreds the thread, as shown in Figure 11-3. Even if the rollers fit perfectly, they would form a rolling scissor edge, likely to cause fiber damage or at least jamming. This problem is a result of the fact that the slack incoming thread does not necessarily enter the rollers straight-on.

11.1.3 Multiple Wraps

If the roller has multiple wraps, the thread will migrate to one edge of the roller as it is payed-out. This happens because the helix angle of the wrap is necessarily nonzero. Once the thread has reached the roller wall, the thread entering the roller will rub between the outgoing thread and the wall. When thread is being taken-up, this pinching action is enough to cause the slack thread that should be exiting the roller to simply wrap around it, as shown in Figure 11-4. Inevitably this jumble of thread interferes with some part of the mechanism.

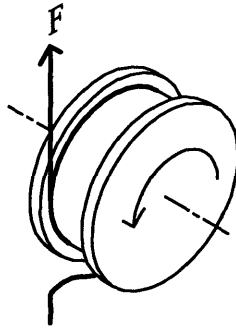

Figure 11-4: Problems with Multiple Wraps

11.2 Displacement-Release with a Restrained Spool

The one rotary thread handling mechanism that does not have any of these problems is the constrained-spool mechanism, because in that case there is no slack thread. This solution is apparently not-so-clean because, as we have seen in Section 10.2.1, there is considerable complication in compensating for different thread diameters as the spool empties.

However, such a conclusion would be a mistake for, as we have already seen, displacement-release mechanisms—at least ones that are not Series 1—do not depend heavily on the details of the force during release (Section 8.5). The torque applied on the spool could even be a binary release/do-not-release choice if it is a properly designed displacement-release mechanism. To be extra safe, one could also desensitize the applied torque to radius variations by using the same mechanical-feedback arrangement that desensitized the mechanism to friction variation (Section 9.3). After all, variation in $R\mu$ can be treated like variation in μ .

The mechanism in Figure 10-10 can be adapted to use a restrained spool. This provides some advantages and gives the final design.

11.3 Final Design

The final bias-package design is illustrated in Figure 11-5. It is a refinement of the design shown in Figure 10-10. The basic structure is two laser-cut 1/8" aluminum plates. The tensioner frame holds all of the thread tensioning components, while the grip plate holds

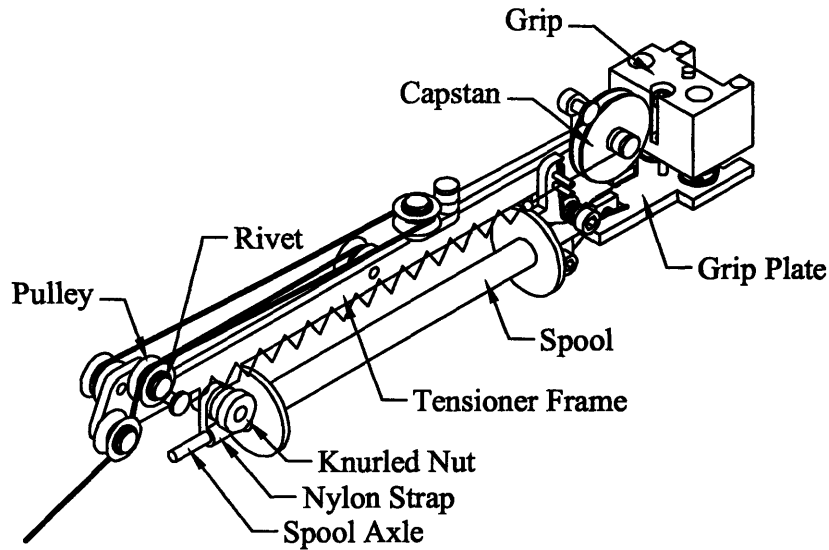

Figure 11-5: Final Design, Isometric View

components related to the bias-package shifting mechanism. The two plates are connected together by two screws and square nuts that fit into features in the plates. Each of the pulleys is made of nylon, and fastened to the frame by a press-fit rivet. The spool itself turns on a brass rod which is affixed to the frame by nylon straps. Removing the spool requires loosening one knurled nut, and sliding the brass rod slightly.

A side view of the tensioner, better illustrating the functionality of the mechanism, is shown in Figure 11-6. In this mechanism, the spring is not connected directly to the floating pulley. Instead, it is connected by a string through a two-diameter capstan. This capstan offers a mechanical advantage between the floating pulley and the spring. This means that even though there is only one sprung loop of thread—rather than the two that were used before—the spring undergoes a smaller deflection over the take-up range. This capstan allows the spring to run along side the sprung loop, a packaging advantage that allows the large motion of the floating pulley. The capstan was manufactured by press-fitting a nylon spacer into a plastic pulley.

The release mechanism works as follows: As the thread is pulled from the package, the floating pulley moves forward, and the spring stretches. As the floating pulley approaches the end of its travel, a bead at the end of the spring comes in contact with the catch pins

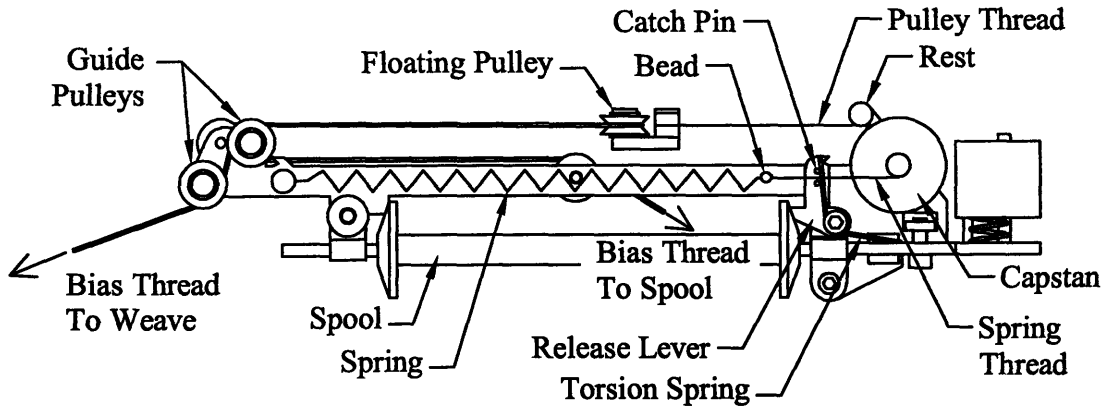

Figure 11-6: Final Design, Side View

on the release lever. Normally, the release lever is preloaded against the spool by a torsion spring, preventing rotation of the spool. But as the bead presses on the catch pins, the lever is lifted off the spool, allowing it rotate and pay-off thread. This limits the travel of the floating pulley. If the thread is fed back into the bias package, the floating pulley takes it up.

In this design, nothing drags on the thread itself. The release mechanism operates on the spool itself, instead. The changing-radius and exit angle of the spool is not a problem because this release is imparting a go-stop force on the spool, not a drag torque, in accordance with the discussion in Section 11.2. The thread tension is set by the critical extension of the main spring. This arrangement has the additional advantages of preventing excess spool rotation—there is never any slack thread anywhere in the system.

To that ensure a minimal tension increase is required to release the spool, there is a large mechanical advantage between the floating pulley and the release lever's contact with the spool. The torsion spring is also as small as reasonably possible, so the normal force is not unnecessarily large. Furthermore, the release lever squeezes the spool against a rubbing feature on the frame, effectively doubling the friction coefficient.

The thread exiting the bias package runs over two pulleys. These replace the eyelet in the previous version, for less thread wear. Their relative location ensures that the thread never loses contact with either, and so the thread is contained. The open design ensures

the entire package can be loaded without letting go of the thread end. That is, the string never needs to be threaded through any holes. The rest near the capstan aids the loading process by forming a place for the floating pulley to sit while the thread is routed through the pulleys.

11.4 Summary of the Design Process

1. The design is driven by the tensioning and take-up requirements. These requirements imply that the tensioner must do work, which means that the tensioner must be powered or store energy. Springs are the sensible choice for energy storage. They are simple and avoid the power-transmission problems of powered tensioners.
2. The displacement of springs must be limited. A release element can accomplish this. There are six possibilities for how release elements may be used. These come from combinations of
 - Three possible arrangements of the release element and spring (Series 1, Series 2, or parallel).
 - Two possible means of determining when the release should occur (force- or displacement-release).
3. There are a number of problems associated with particular possibilities.
 - Force-release mechanisms—if embodied in the simplest way—will depend on the (uncertain) coefficient of friction between rubbing parts. Alternatives are possible, but are likely more complicated (typically using a displacement-release submechanism). Also, there may be a risk of uncertain spring extension due to low spring rates, even where the release force is well controlled.
 - Series 1 designs will likely have poor dynamic behaviors when releasing is in progress.
 - Series 2 designs require a rotary adaptor, which has slack-thread-feeding problems (see next item). If the mechanism is also a displacement-release mechanism, one

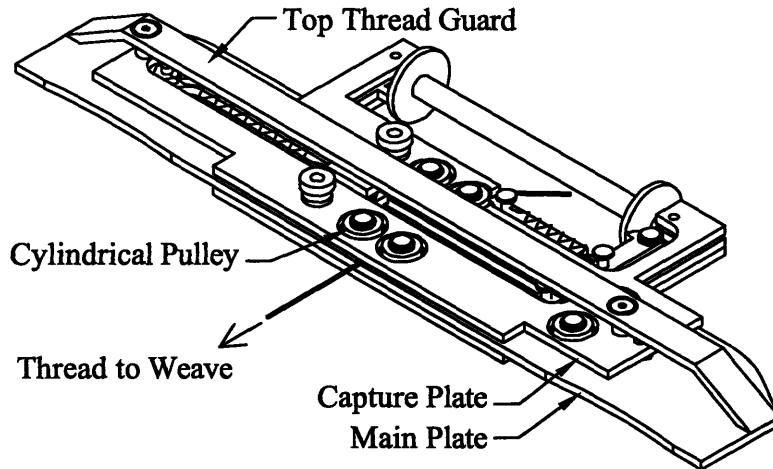

Figure 11-7: Shuttle, Side View

has complications stemming from the need to measure the relative displacement between two moving points.

- In general, it is difficult to prevent slack thread from tangling or getting caught in the mechanism.

4. A displacement-release, parallel mechanism avoids all these problems, and can be made to meet all the other functional requirements.

11.5 Shuttle

This same tensioning approach was also applied to the design of a shuttle, which is shown in Figures 11-7 and 11-8. The different packaging requirements and smaller take-up requirements allowed the same basic mechanism to be applied in a more convenient fashion.

The shuttle is constructed of three aluminum plates. The main plate is shaped according to the requirements of the arms that pass it back and forth. A thread guard on the top and bottom ensures that the threads of the shed do not catch on the mechanism. The top thread guard and capture plate come off as a unit (after the removal of two thumbscrews) to open the mechanism for loading. When closed, the thread is fully captured and can go completely

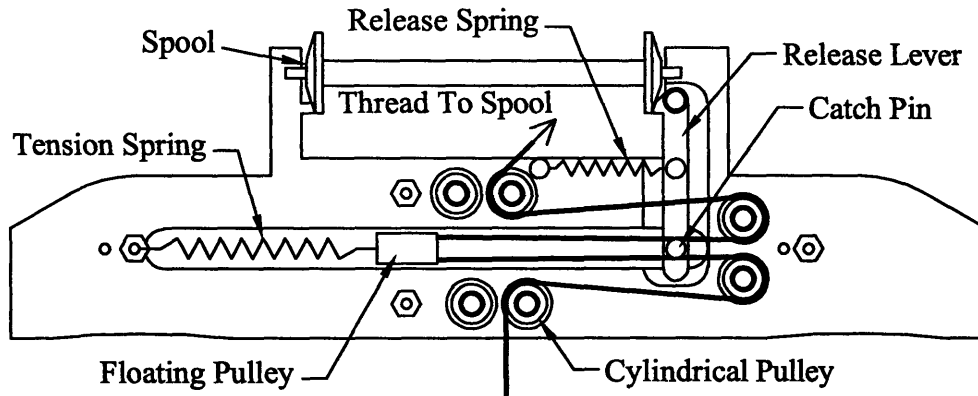

Figure 11-8: Shuttle, Top View, Opened

slack without coming out of position; this is not the case with the bias package, which can count on gentler movements. The thread is captured between the capture and main plate. The pulleys are cylindrical, but extend into a hole on each plate so the thread cannot run off the ends. The floating pulley is similarly constructed.

Less stringent spacing and take-up requirements allow the spring to be directly attached to the floating pulley. This pulley comes into direct contact with the catch pin when the thread loop is empty. Otherwise, its basic operation is similar to the bias package.

11.6 Adjustable Tension

One simple variation that could be applied to this type of mechanism is to use the same spring for tensioning and holding the release lever. This might be done by attaching one end of the spring to each of the two items, or having the three items linked by an adding element. In such an arrangement, the release-lever friction would automatically adjust to the changes in the thread tension. This would allow one to more easily change the tension on the thread, by changing the spring constant or pre-stretch on one spring instead of two.

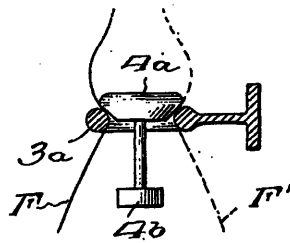

Figure 11-9: Non-Retracting Tensioning Method. Drawing from [26]

11.7 Comparisons with Prior Art

A wide variety of tensioning mechanisms have previously been designed. Some of them reject the the spring premise in favor of active tensioning methods, such as electric motors [15]. Others are embodiments of the mechanisms in Figure 8-2, and some resemble the presented designs. Below are a few examples.

Force-release mechanisms have been developed for non-retracting tension devices. Some of these straightforwardly use friction, others are friction insensitive. In one common device, the thread runs through a ring and a ball or plug is preloaded into that ring. Figure 11-9 shows this mechanism from [26]. Ideally, as the thread tension become great enough to overcome the preload force, the plug lifts and allows more thread to pay-out. This is analogous to the mechanical-feedback device shown in Figure 9-10, although there is likely some unregulated friction effect as well. It appears that less attention is generally paid to using mechanical advantage to get a large K .

Other designs have been proposed for tensioners with the ability to take-up thread. For instance, [14] presents a thread package, shown in 11-10, that is a Series 1, force-release design. It is rather similar to the design shown in Figure 10-2, except the spring and friction elements are in the opposite order, and there is no provision for radius compensation. There is also, as in many of the designs presented here, a mechanical advantage between the thread and the spring.

There is a number of existing designs that are more-similar to the new tensioner developed for the proposed bias-weaving machine. At the highest level, these designs all share the following features with new design:

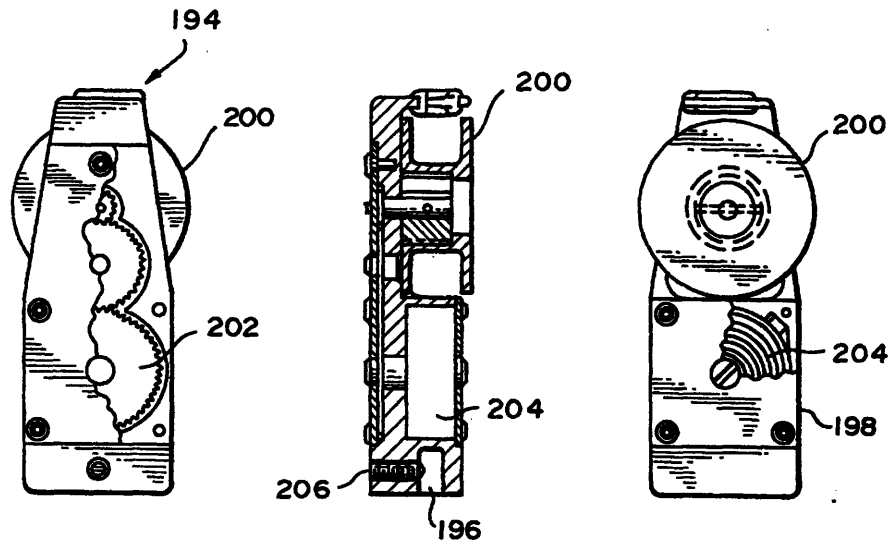

Figure 11-10: Retracting Tensioning Mechanism. Drawing from [14]

1. An accumulator made from one or more moveable pulleys (e.g. the floating pulley). This takes-up any thread that is fed back into the tensioner, and empties as thread is pulled out
2. A mechanism to selectably release or ground the spool
3. A means of actuating the release when the accumulator is sufficiently empty, so that the more thread feeds off the spool into the accumulator

Figure 11-11, taken from [18], shows one such design in a particularly clear manner. One can see functionally analogous pieces of this tensioner and the final tensioner (Figure 11-6).

The next conceptual level to the design is the use of a friction-based release, as opposed to using pawls. In this detail, the most similar [23] directly squeezes the spool between brake shoes—as in our tensioner—although the accumulator looks rather different. This tensioner is shown in Figure 11-12. Other variations have more-similar accumulators, but more-different friction systems, such as a cone clutch [8], a spring clutch [32, 24], or balls jamming against wedges [33].

A common feature of all of these—including the new tensioner presented here—is that mechanical advantage (or a self-energizing brake) is used so that only a relatively small

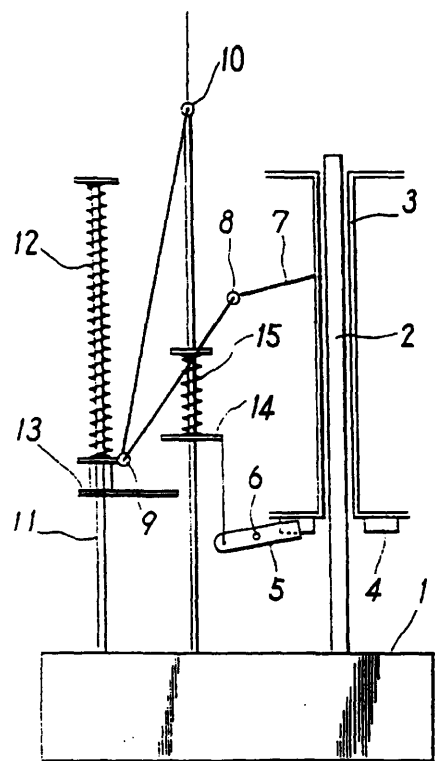

Figure 11-11: Displacement-Release Tensioning Mechanism. Drawing from [18]

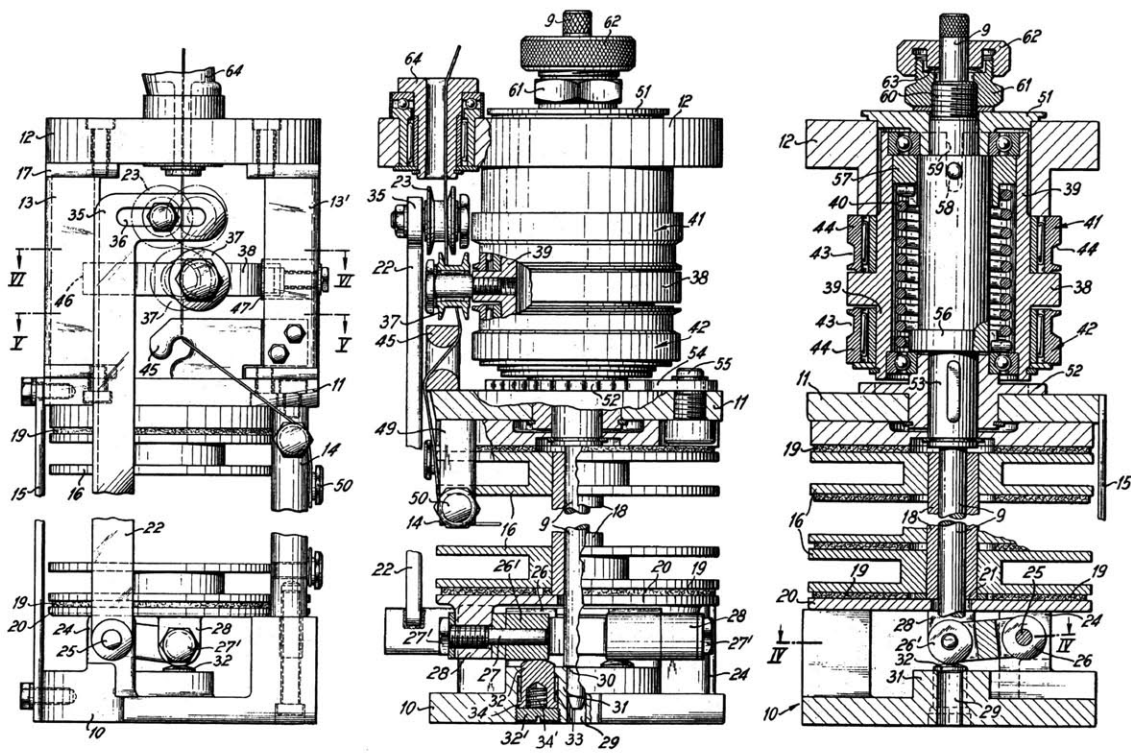

Figure 11-12: Friction-Based Displacement Release. Drawing from [23]

additional force at the thread is necessary to disengage the friction element. It should be emphasized that the release is controlled by displacement of the thread rather than the force on it; the force increase is a necessary side effect.

The new tensioner gets part of this mechanical advantage from the geometry of the release lever (longer distance from the fulcrum to the catch than to the friction area) and by squeezing between two brake shoes, a combination used in [23]. The other part of this mechanical advantage derives from the two-diameter capstan between the floating pulley and the catch bead. This detail seems to be new, and is related to the other differences between this tensioner and prior art.

These differences all surround the floating pulley, which is only supported by tension. The analogous devices on similarly-designed prior art have unnecessary supporting bearings. Similarly, the bead (or other object: e.g. the floating pulley in the shuttle) that catches and pushes the release lever at a certain displacement is supported only by the tension and is directly attached to the connection between pulley and spring.

These items are somewhat separate, but work well together. The two-diameter capstan could be omitted, but (besides the mechanical advantage mentioned before) it adds the benefits of more convenient packaging (spring and floating pulley parallel), and reduced spring extension. These and other construction details result in dramatically simplified construction, with both fewer and less-precise parts.

A quick glance at the “similar” prior art cited will reveal many dramatically different-looking designs. The design process that was used here—building from an idealized abstract design—is very helpful in identifying analogous parts by function. It helps strip away the differences in structure. It also helps to insulate the designer a little, so as not to be unduly influenced by the details of previous designs.

Chapter 12

The Braiding Machine, As Built

The proposed braiding machine was built and operated, with shuttle and bias packages as described. Figure 12-1 shows the machine, as seen from the front-right side. The finished weave is emerges at the bottom left of the photo. The shuttle arms and reed drive motor can also be seen at the front of the machine. The Jácquard machine can be seen at the top; cords from it run through a curved comberboard behind the columns, and to a traditional heddle assembly below that.

Figure 12-2 shows a closer view of the column array with the bias packages. The reed blades can be seen in front of the spools. One can also see how the threads converge towards the fell. As shown, the columns are in the up-most position, for passing fill under all the spools. An even closer view of the spools on the columns is shown in Figure 12-3.

The machine can produce bias weaves up to approximately 4" wide. It has 32 columns and nine bias positions per column. The ninth bias position does not generally contain bias packages during weaving. Rather, it provides empty bias positions that can be lined up on the shifting row when, for example, one wishes to shift half a row of bias packages only. In practice, this is not unusually necessary, because in such cases empty bias positions usually exist naturally elsewhere. The ninth row can also be used to evacuate and replace any bias spools that are almost empty.

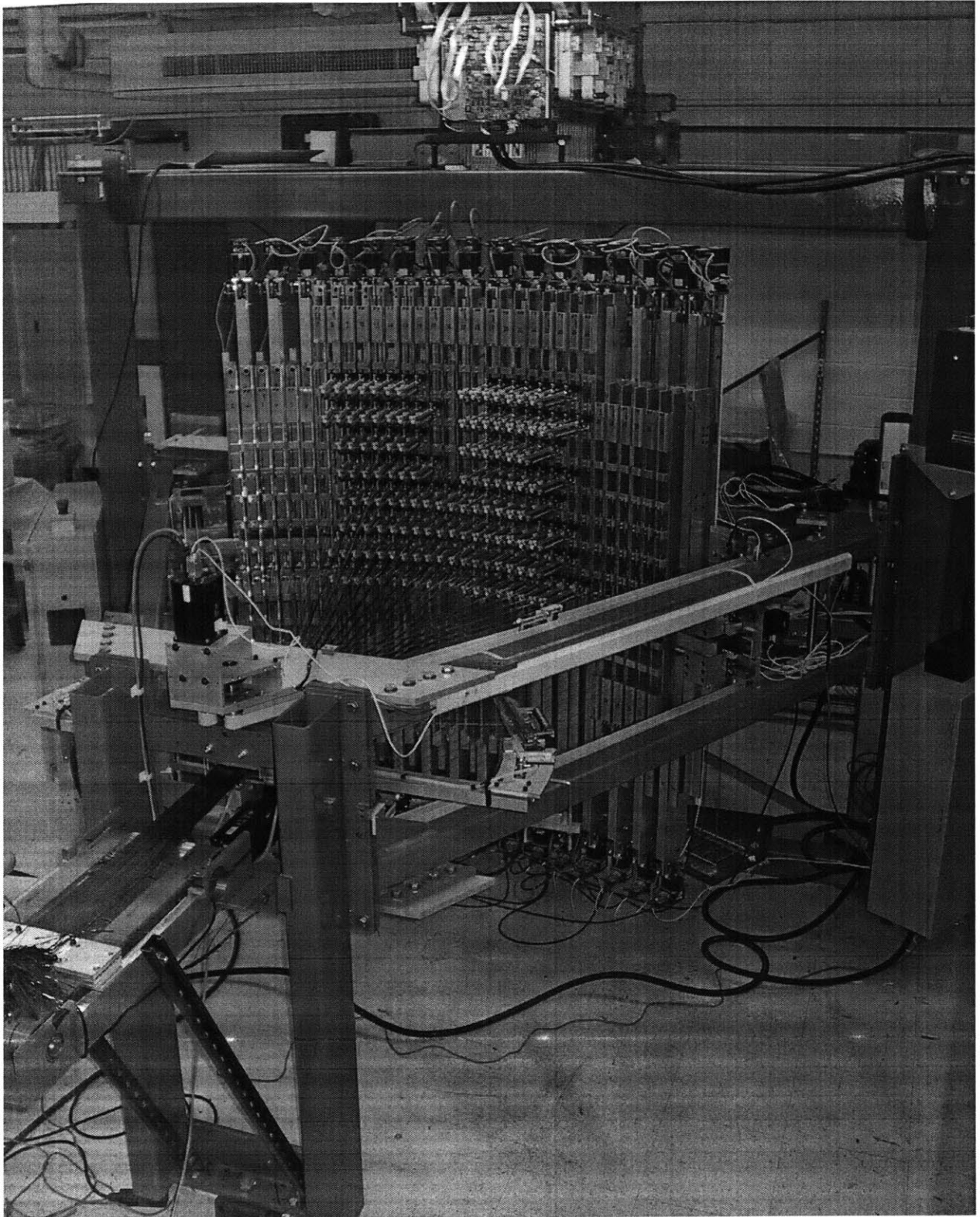

Figure 12-1: The Bias-Weaving Machine, As Built

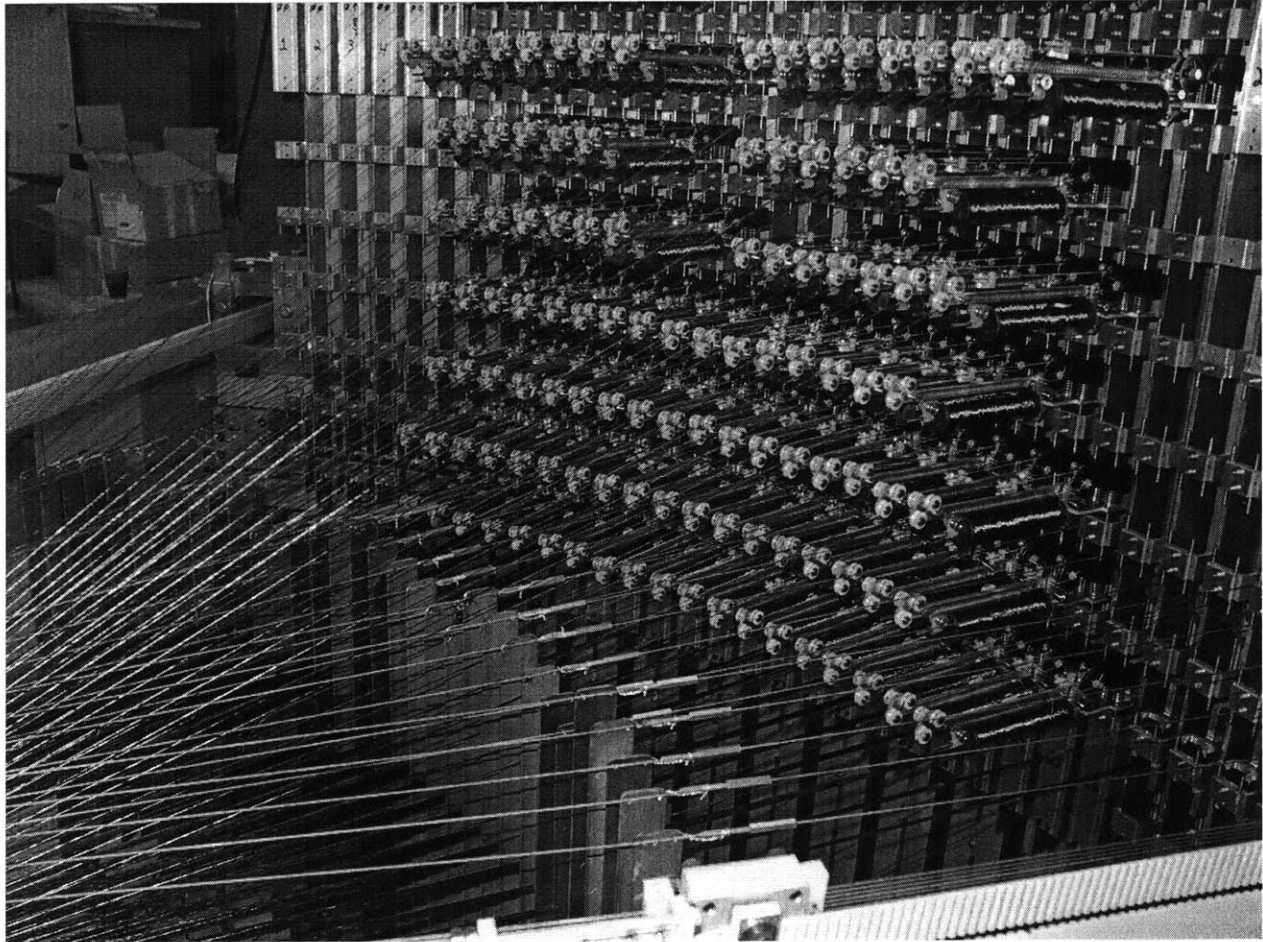

Figure 12-2: The Column Array

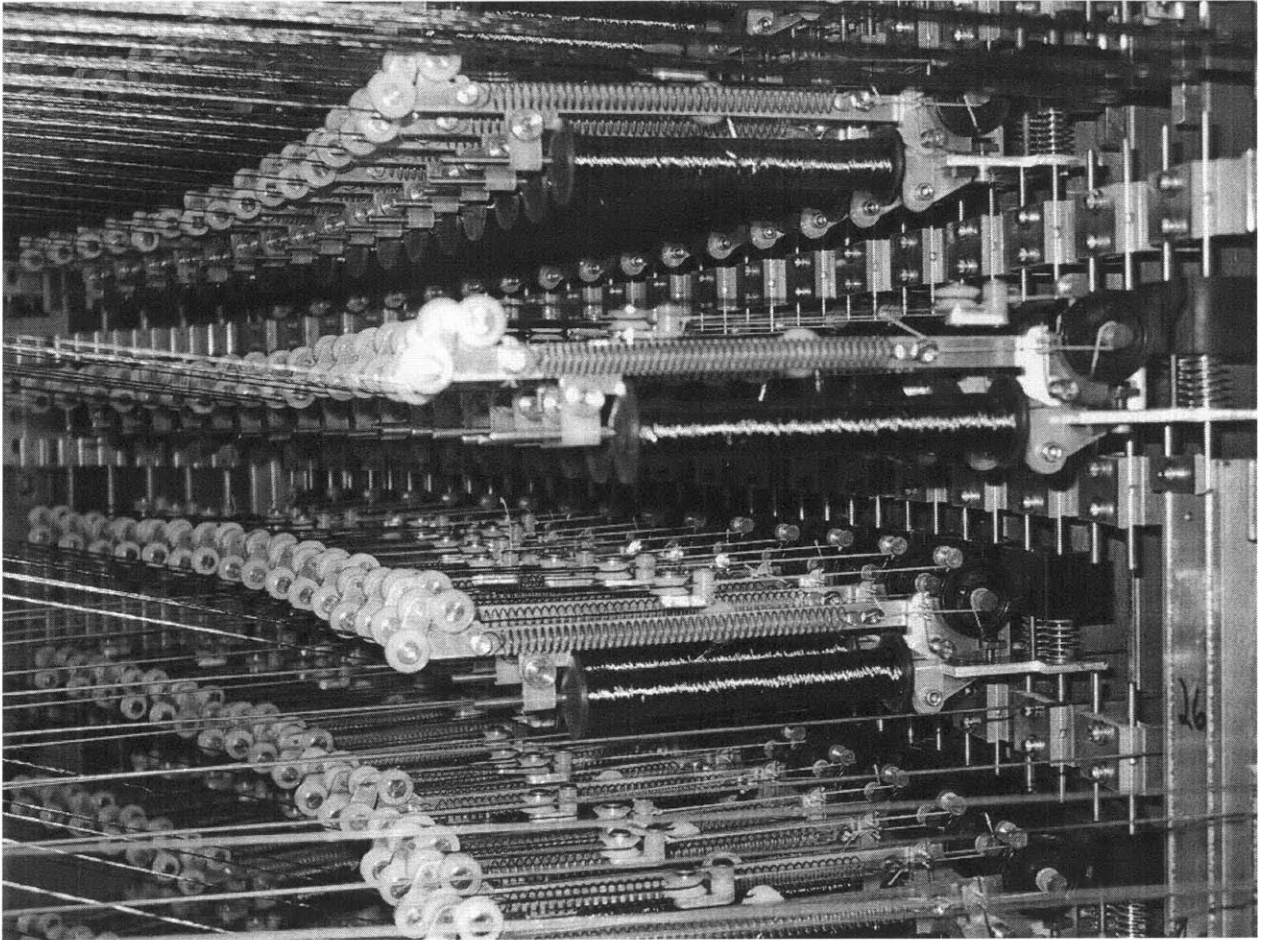

Figure 12-3: Bias Packages

12.1 Practical Notes on Bias Weaving

The machine was used to produce a variety of different weaves; the largest had approximately 125 bias yarns and 400 warp yarns. The weaves were mostly constant cross-section, so the machine could repeat the exact same set of movements indefinitely. Typically, all the fill passes for one cross-section occurred one after the other. Then all the shifting operations happened, to advance the bias spools by one position. Then the sequence repeats. Take-up was usually done in one movement at the end of the sequence, although on the largest weaves another take-up movement was used halfway through the filling portion of the sequence, as well.

Beat-up occurred after each fill pass. Typically, no beat-up was done after the bias shifts, because the bias fibers would just return to their original location afterward, meaning beating-up would just cause extra wear. The bias threads do not hold in the correct position by themselves; the warp and fill threads are needed to hold them there. Because of this, the bias weave does not take its final form right at the fell. Instead, it takes its final form after a few additional cycles, when some more fill had been inserted. This means there was a quarter-inch or so of transition that was always just behind the fell.

Some $0^\circ/90^\circ$ weaves and ways of including the bias layer worked better than others. Below are a few examples of weaves that worked reasonably well. They also demonstrate a few useful details.

12.2 Example Weaves

Figure 12-4 shows a cross-section of the first example weave, called weave A. The diagram uses the same conventions as Figure 6-15, except the direction of the fill and shifts are indicated by an asterisk located near the beginning of the route in question. Weave A has a T-shaped cross-section (shown in Figure 12-5), with one interwoven bias layer, in the center of the left leg and on the surface of the lower-right leg. The bias layer is joined to the rest of the weave by fill fibers that move above and below the bias crossings.

One could imagine tying the bias yarns to the rest of the weave by, instead, using warp

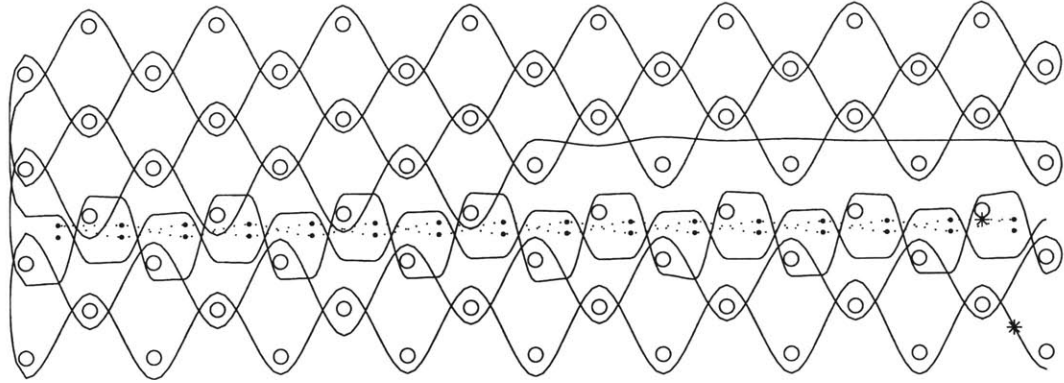

Figure 12-4: Example Weave A

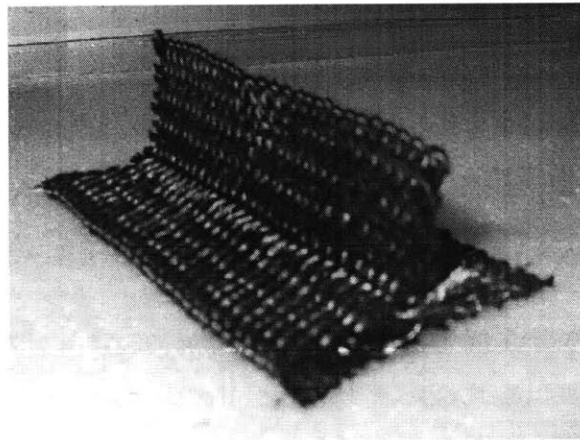

Figure 12-5: Picture of Example Weave A

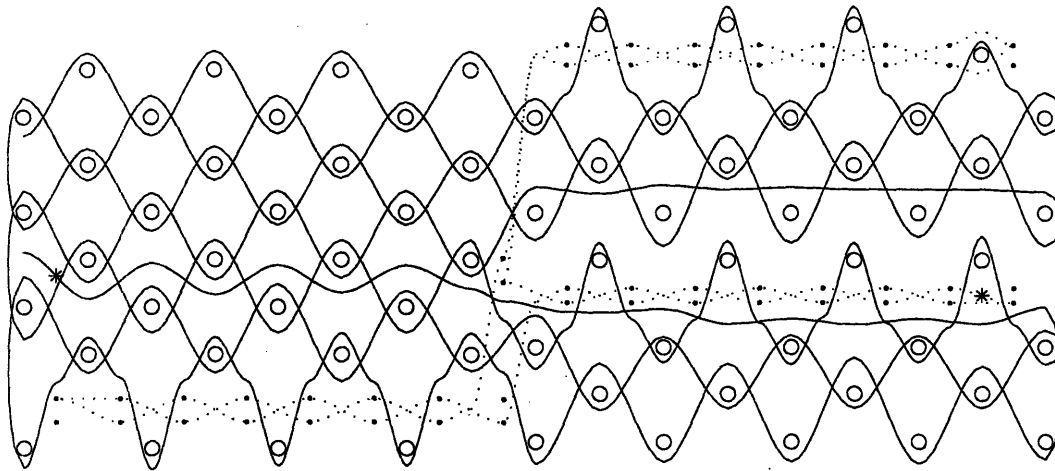

Figure 12-6: Example Weave B

fibers which cross above and below the bias layer, as if the weave were turned 90°. In practice, this alternative type of weave worked less well. It also could not be drawn in cross-section form.

Weave B, shown in Figure 12-6, has a similar cross-section, but a different bias-layer arrangement. Figure 12-7 shows a sample of this weave (the threads on the lower edge of the sample have been cut). In this weave, the bias fibers run along the surface of each leg, in one loop. At the top-left bias turn, the bias yarns encircle a warp fiber, to pin the bias layer to the edge of the weave. Again, the bias layers are interwoven. However, they are tied to the rest of the weave in a different way.

On the left side (for instance), all the fill fibers run above the bias yarns, and there is one set of warp fibers below the bias yarns. One fill fiber passes through the diamond-shaped holes in the bias layer, under those axial fibers, and then back up through the bias layer. It is the combination of warp and fill fibers that binds the bias layer in place. This is a nice way to structure the weave, because the columns move less when inserting fill fibers, and it is very easy to plan.

Weave C, shown in Figure 12-8, uses the same method of tying the bias layer to the rest of the weave, but with a pi-shaped cross section. It has two separate bias loops, forming bias layers in each of the legs. This weave was designed in an effort to guarantee a nice selvedge:

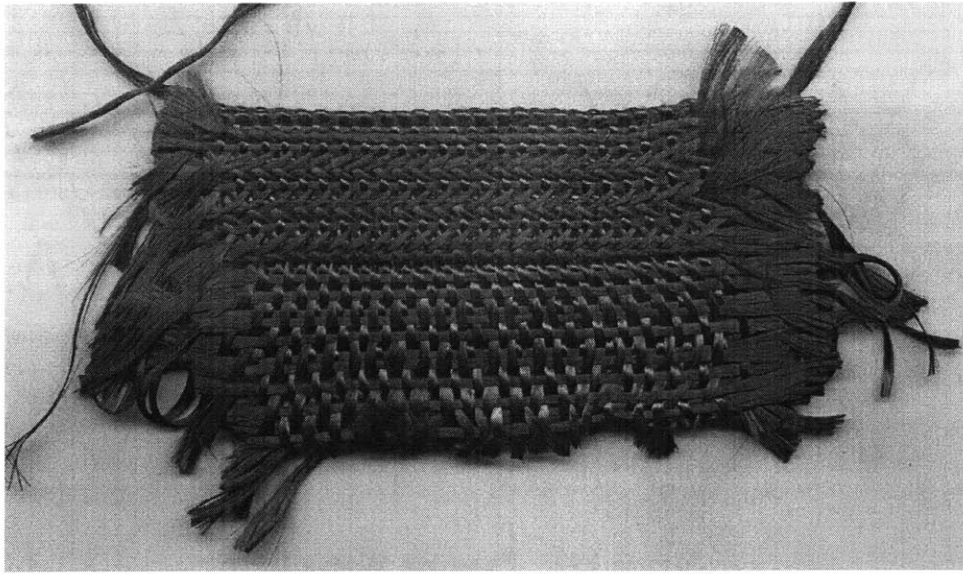

Figure 12-7: Picture of Example Weave B

It was observed that the fill fibers which join the bias layers to the rest of the weave cause an irregular selvedge because they do not lie close to the fell prior to beat-up. Instead, their relatively tortuous path causes them to remain farther from the fell, resulting in excess fiber paying-out from the shuttle, and therefore the creation of a small loop at the selvedge at beat-up.

To alleviate this problem on this weave, an individual fill fiber binds at most half of the bias layer—so that the path is less tortuous and the fiber lies closer to the fell—and is followed by a relatively straight pass that encircles the entire selvedge—to guarantee a properly-tensioned turn around the edge fibers.

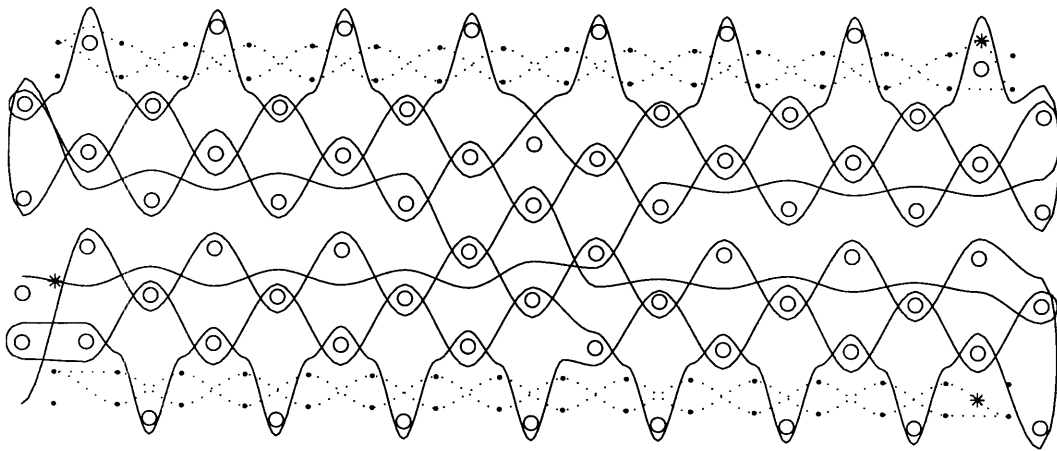

Figure 12-8: Example Weave C

Bibliography

- [1] Sappinandana Akamphon. Control of a bias weaving machine. Master's thesis, Massachusetts Institute of Technology, 2004 [Expected].
- [2] Betta. US Patent 4,380,949: Braided stranded rope forming machine, 1983.
- [3] Steven Clarke. Engineered textile preforms for RTM: A comparison of braiding, knitting and weaving technologies. *SAMPE Journal*, 34(2):35–37, March/April 1998. Note: Does not discuss multiaxial weaves.
- [4] Mauricio Diaz. Design of a bias-weaving machine: Bias thread shifting. Master's thesis, Massachusetts Institute of Technology, September 2003.
- [5] Anahara et al. US Patent 5,137,058: Three dimensional fabric and method for producing the same, 1992.
- [6] Ashton et al. US Patent 4,898,067: Combing apparatus for braiding machine, 1990.
- [7] Brookstein et al. US Patent 5,357,839: Solid braid structure, 1994.
- [8] Bull et al. US Patent 4,529,147: Carrier for strand supply bobbin, 1985.
- [9] Bull et al. US Patent 4,535,675: Apparatus for control of moving strands from rotating strand supply bobbins, 1985.
- [10] Cady et al. US Patent 33,569: Braiding machine, 1861.
- [11] Haehnel et al. US Patent 5,775,195: Rotary braider machine, 1998.

- [12] Ivsan et al. US Patent 4,922,798: Apparatus and method for braiding fiber strands, 1990.
- [13] McConnell et al. US Patent 4,719,837: Complex shaped braided structure, 1988.
- [14] Roberts et al. US Patent 5,337,647: 3 dimensional braiding apparatus, 1994.
- [15] Skelton et al. US Patent 4,909,127: Braiders, 1990.
- [16] Tsuzuki et al. US Patent 5,067,525: Three-dimensional fabric woven by interlacing threads with rotor driven carriers, 1991.
- [17] Florentine. US Patent 4,312,261: Apparatus for weaving a three-dimensional article, 1982.
- [18] Kimbara. US Patent 5,870,940: Yarn tensioning method and device for textile weaving machines, 1999. See Figure 16.
- [19] T. D. Kostar, T.-W. Chou, and P. Popper. Characterization and comparative study of three-dimensional braided hybrid composites. *Journal of Materials Science*, 35:2175–2183, 2000.
- [20] P. R. Lord and M. H. Mohamed. *Weaving: Conversion of Yarn to Fabric*. Merrow Publishing Co. Ltd., Shildon, England, 1982.
- [21] Kunio Murasugi and Bohdan I. Kurpita. *A Study of Braids*. Kluwer Academic Publishers, Boston, 1999.
- [22] A. Newton and B. P. Sarkar. An analysis of compound weaves. *J. Text. Inst.*, (10):427–438, 1979.
- [23] Ostermann. US Patent 3,359,848: Carrier for braiding machines, 1967.
- [24] Richardson. US Patent 3,817,147: Braider carrier, 1974.
- [25] Spring Manufacturers Institute, Oak Brook, IL. *Encyclopedia of Spring Design*, 2000.
- [26] Stevenson. US Patent 2,373,513: Tension and bloom control device, 1942.

- [27] Trautvetter. US Patent 1,184,790: Loom, 1916.
- [28] Ph. Vandeurzen, J. Ivens, and I. Verpoest. A three-dimensional micromechanical analysis of woven-fabric composites: I. geometric analysis. *Composites Science and Technology*, 56:1303–1315, 1996.
- [29] Emily Warmann. Design of a bias-weaving machine: Fill insertion and beat-up. Master's thesis, Massachusetts Institute of Technology, September 2003.
- [30] F.T.I. Watson, William. *Watson's Advanced Textile Design : Compound Woven Structures*. Newnes-Butterworths, Boston, 1977.
- [31] Eric W. Weisstein. Braid group. <http://mathworld.wolfram.com/BraidGroup.html> maintained by Wolfram Research, Inc., accessed 2003.
- [32] Wily. US Patent 3,839,939: Strand carrier for braiding machines, 1974.
- [33] De Young. US Patent 3,756,533: Strand tension-controlling and spool release actuator mechanism, 1973.