

**city of waiting**

a primary healthcare center for laguna beach, california

**ROTCH**

by

timothy m. morshead  
bachelor of environmental design  
university of colorado, 1998

submitted to the department of architecture in partial fulfillment  
of the requirements for the degree of master of architecture  
at  
the massachusetts institute of technology  
february 2004

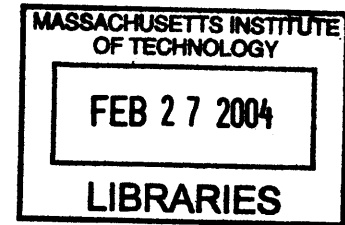

© 2004 timothy m. morshead all rights reserved

The author hereby grants to MIT permission to reproduce and to distribute publicly  
paper and electronic copies of this thesis document in whole or in part.

january 8, 2004

Timothy M. Morshead  
Department of Architecture

J. Meejin Yoon  
Assistant Professor of Architecture  
Thesis Adviser

Bill Hubbard, Jr.  
Adjunct Associate Professor of Architecture  
Chairman, Department Committee on Graduate Students





## **Thesis Committee**

Advisor: J. Meejin Yoon, Assistant Professor of Architecture  
Readers: Fernando P. Domeyko, Senior Lecturer in Architecture  
Ann M. Pendleton-Jullian, Associate Professor of Architecture



## **city of waiting**

a primary healthcare center for laguna beach, california

by

timothy m morshead  
bachelor of environmental design  
university of colorado, 1998

submitted to the department of architecture  
in partial fulfillment of the requirements  
for the degree of master of architecture  
at  
the massachusetts institute of technology  
february 2004

© 2004 timothy m morshead all rights reserved

The author hereby grants to MIT  
permission to reproduce and to distribute publicly  
paper and electronic copies of this thesis document  
in whole or in part.

## **Abstract**

A design inquiry was undertaken into the alienating spatial qualities of healthcare facilities. The spatial tissue of the modern hospital and clinic was found to correspond tightly with Michel Foucault's definition of an institutional "disciplinary environment." As market-driven healthcare systems compete for patients, institutional power structures are being reversed. Patients have acquired the power of consumers. A new healthcare center must be an inherently open, non-disciplinary environment.

On average, half of the time spent within a healthcare building is spent waiting. Yet the activity of waiting is thinly defined and unsatisfactorily inscribed by isolated waiting rooms. This thesis proposes that the realm of waiting be delimited, reconceptualized, and reconfigured in relation to building circulation and medical care spaces in order to catalyze a loosening of the traditionally closed clinical environment and its integration into the physical fabric and social life of the city.

Strategies and tactics are described to reconsider the waiting experience and other overconstrained components of healthcare architecture. These tactics are deployed and tested in the design of a primary healthcare center in a small beach-side city.

Advisor: J. Meejin Yoon  
Title: Assistant Professor of Architecture





Waiting room, Boston

## **introduction**

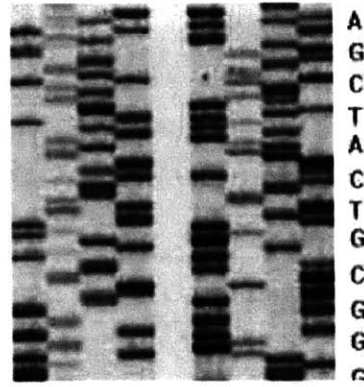

### (De)Limiting Programs

While most every perceptual comparison between man and mouse—size, shape, sound, feel, disposition—evidences a world of difference between the two, an analytical comparison reveals a striking topological similarity. The nucleotide sequence of a mouse differs from that of a human by only a fraction of one percent. Genetically, our species are nearly identical. The 99% of similar DNA is that which is responsible for enforcing basic order on chemical systems, conjuring working cells and tissues out of inert chemicals. And as with most ordering systems, this DNA is essentially a limiting mechanism. It limits which compounds will be assembled, which will interact, and in what order. Yet the other one percent of DNA, the delimited genetic material, is able

to contain and describe a whole difference in species, not to mention the entire range of individual physical variation. The relationship of freedom to constraint is neither linear nor fixed in the cellular system of the body. More constraint does not necessarily mean less freedom.

I am interested in the architecture that architects don't do; or, to be more specific, those situations and/or programs with such excesses of constraint—physical constraint, economical constraint, technical constraint, organizational constraint—that free architectural discourse is almost entirely marginalized. Housing, industrial buildings, transportation infrastructure, and hospital complexes are clear examples. The idea of constraint and contingency has long been anathema to modern architecture. The

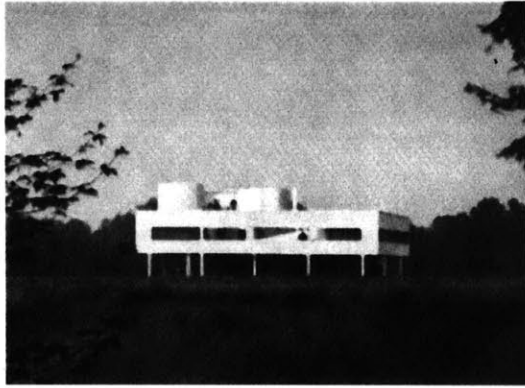

open landscape around Villa Savoye



hillside terraced for subdivision construction!

modernist archetype of the single-family house, for example, operates most effectively in a *carte blanche* condition. In the case of Corbusier's Villa Savoye, a singular wealthy client removed organizational and economic constraints. The smooth grassy site, though accommodated minimally by the house's orientation, presents few physical constraints. The majority of housing, on the other hand, is highly constrained by market forces and available construction techniques.

### Constrained Care

*The hospital* and its more nimble progeny *the clinic* are perhaps the clearest examples of over constrained programs. Firstly, there are immense mechanical constraints. The need for fresh

disease-free air and ample light deep within these often expansive structures requires mechanical spaces that rival in size the inhabitable spaces they serve. Secondly, there are organizational and economic constraints. Whether the product of socialism or private HMOs, health care buildings reflect the strict economic environments in which they were produced. Health care buildings inscribe, accommodate, and support a complicated and expensive service that many perceive as a basic human right. This is increasingly expensive as medical technology becomes more pervasive and sought after.

The hospital is a battleground between the sick individual and the bureaucracy which administers his or her care. These bureaucratic organizations are increasingly unstable. Great Britain is now



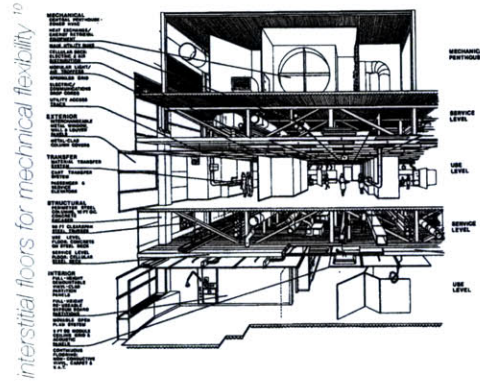

Norwich Park Hospital. The apotheosis of the modern superhospital.<sup>2</sup>

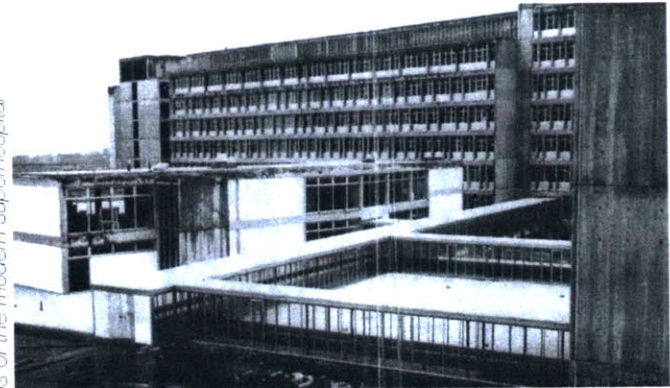

experimenting with selective decentralization, and even privatization, of its bloated National Health Service. The average size of new health care buildings has fallen in response to economic demands. In 1970 the NHS commissioned the Norwich Park District Hospital. This 800 bed behemoth stood on 48 acres of isolated parkland and was the most expensive NHS project ever. Today, the NHS tends to sponsor many smaller primary care centers which operate in networks with larger surgical centers and inpatient facilities. These smaller venues have proven more cost effective for the government and less alienating for the citizens.<sup>7</sup>

In addition to the mechanical, economic, and organizational constraints on the hospital are the cultural and institutional limitations inherent to the program. Clearly, the healing of patients by

the most current needs demands strict and everchanging performance requirements of a building. Performance requirements are objective, quantifiable, and rules-based. As such, they are easily regulated and formalized into crude but very clear architectural diagrams of the constraining forces acting upon them. For



emergency room in Dana Point, California

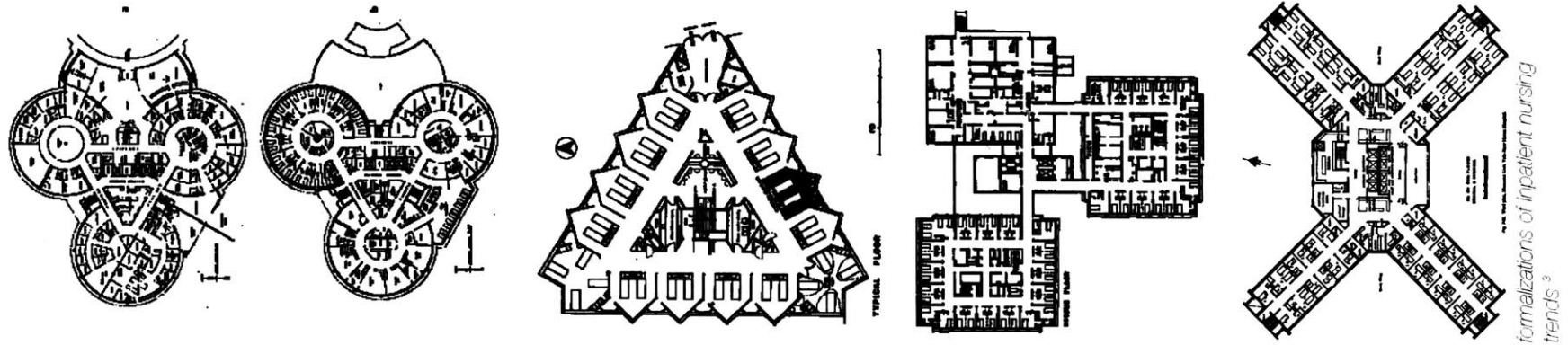

example, the culture of nursing demands quick visual access and short walking distances to patients under care. In the 1960s, researchers at Yale University published a system for quantifying nursing efficiency. This measurement has had a profound effect of the sizes and geometries of inpatient blocks to this day. In response to these constraints, health care buildings and complexes are frequently constructed in remote greenfield locations to avoid the added limitations of site and urbanistic complexities.

### Strategic Freedoms

As architecture becomes increasingly marginalized in our material culture at large, there are lessons to be learned from engagement with these most limiting of programs. Programmatic

limitation can be internalized, transformed, delimited. This transformation requires that form and function enter into a more complex and, perhaps, more slippery relationship. Cause and effect is no longer good enough. Form following function assumes that function is singular, monolithic, and known. The functional requirements of a program are often subjective and plural. And clearly, the forms of buildings alter and create functions.

An uncanny example of leveraging architecture against programmatic constraint is the “Free Lobby” project by Lewis, Tsurumaki, and Lewis. The lobby is a program constrained entirely by its own conventions—a public door leading to a semiprivate space leading to an elevator leading to a single building above. The designers combine the many lobbies of a multi-building city



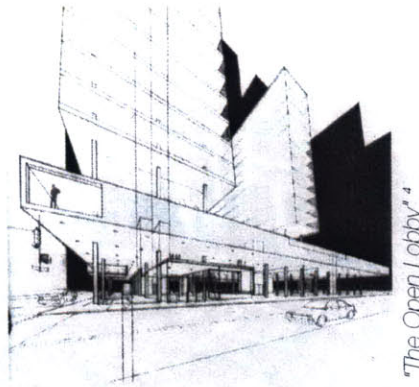

"The Open Lobby" 4

block into a single public space continuous with the life of the street and pierced by multiple elevator cores. The existing formal tissue is selectively transformed, deleted, or amplified to give rise to a new formal and functional hybrid.

L.E.FT Architects also manipulate the existing tissue of a banal program in their "Bed, Bath, and Beyond" hotel project. Here, the hotel room is transformed according to the measured observation that a business traveler spends 50% of his time in the bathroom and 50% in the bedroom of a hotel suite. A redistribution of hotel room space opens up new possibilities for the treatments of materials and surfaces within each room. This delimited architecture creates its own degrees of freedom by creatively engaging the formal and functional seams of a conventional program.

The metaphor of the seam is useful in further examining the relationship

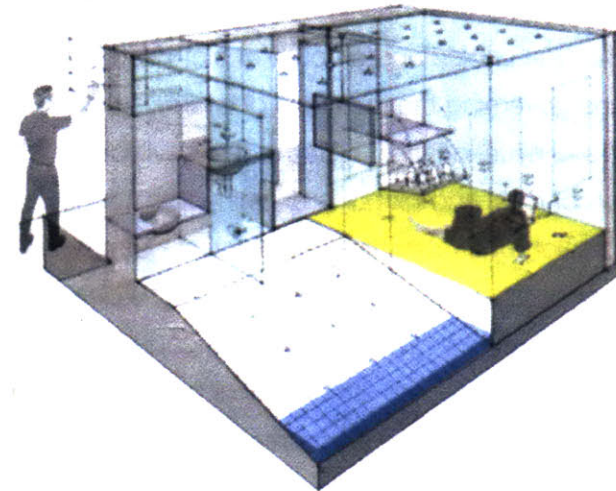
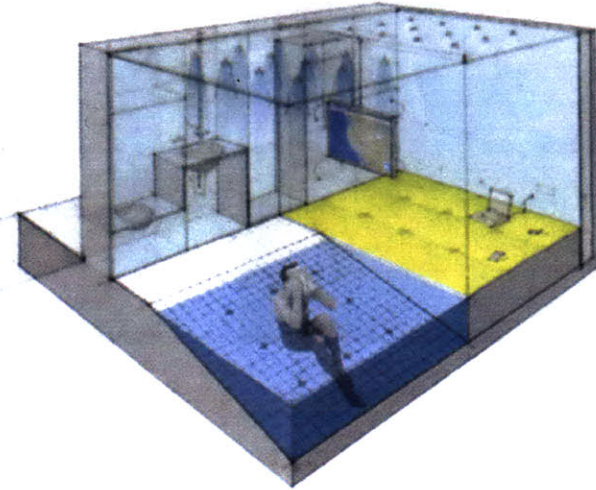

"Bed, Bath, and Beyond" 5



*the seam as a form-giving entity*



*modern carte blanche*

of freedom and constraint. The seam is a local condition, a break and a connection point in a global homogeneous field. The seam in a dress can establish the size of a waistline or the shape of the hem; while the choice and amount of cloth establishes the global conditions governing the locations of seams, such as the types of weather and situations in which the dress will be worn. This juxtaposition of local and global is examined by Michel De Certeau in his conception of strategies versus tactics. Strategies are global definitions, organizations, and orders. They define the boundaries of debate and lay the ground rules for a course of action—design or otherwise. Tactics, are specific local moments where strategies are applied, transgressed, or manipulated.

Though often considered independently, tactics and strategies

are clearly interdependent. For example, part of Israel's strategy for sustained statehood and economic prosperity includes a limited freedom of movement across borders with the occupied territories to allow an influx of cheap Palestinian labor. Palestinian extremists take advantage of this strategic imperative by employing the subversive tactic of suicide bombing. In this way, the global strategy of control influences the mode of local tactical resistance. Or for a more benign example, consider the urban design proposal of OMA for La Defense in Paris. The city's goal was an imposition of meaning and clarity on a large, already developed urban area. OMA determined that the given situation was over-constrained in relation to the lofty goal. In response, the designers made the strategic decision to remove and wipe clean

whole areas of the city according to the age of the buildings. This strategic decision to essentially change the rules of the project released a flood of new opportunities for tactical insertion of a new urban organization—in this case the Manhattan grid.

Furthermore, other tactics were applied in contravention of OMA's own strategy. Buildings of quality or perceived importance within areas of demolition were allowed to remain, adding local specificity to the areas of erasal; in a sense complicating what could have been a problematic *carte blanche* condition. The proposal stands apart from Corbusier's *Plan Voisin* in its acceptance of contingency. The designers operated on both strategic and tactical levels to overcome an overconstrained problem.

When degrees of freedom are created, the question becomes

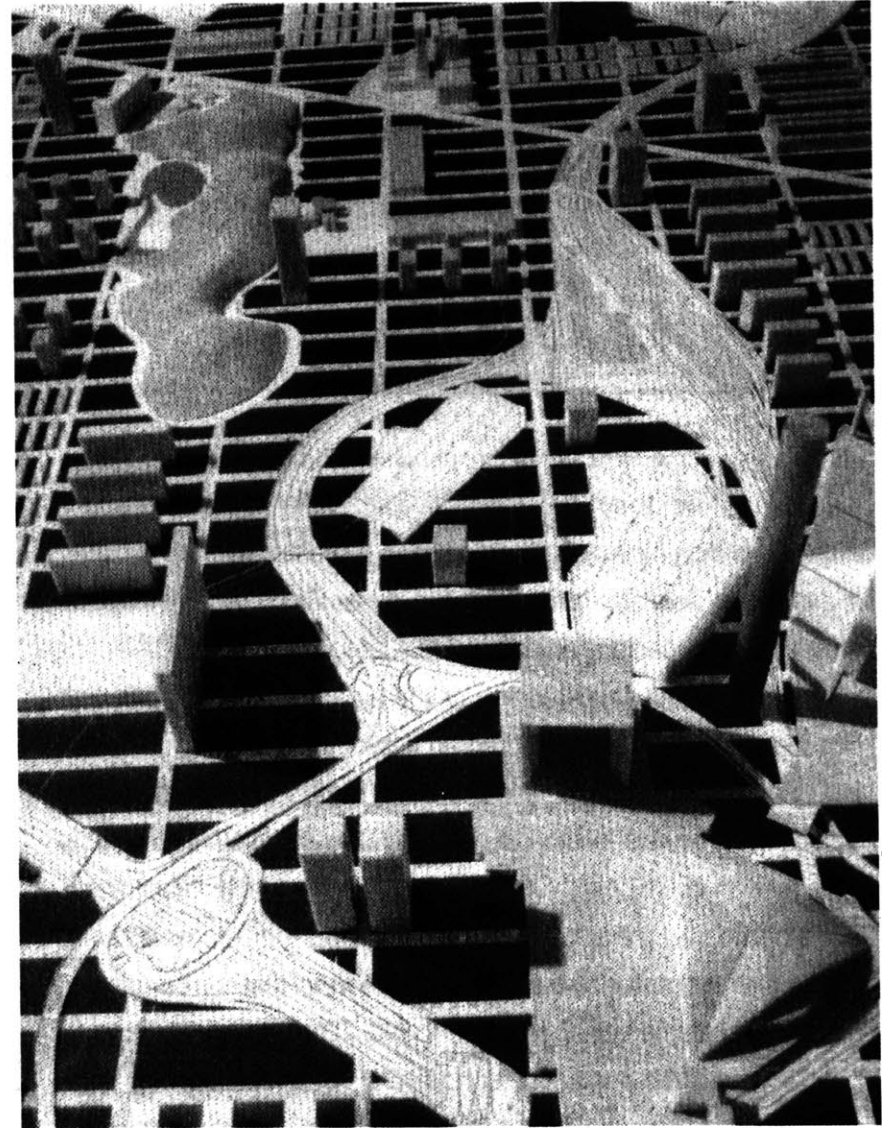

post-modern *carte blanche*



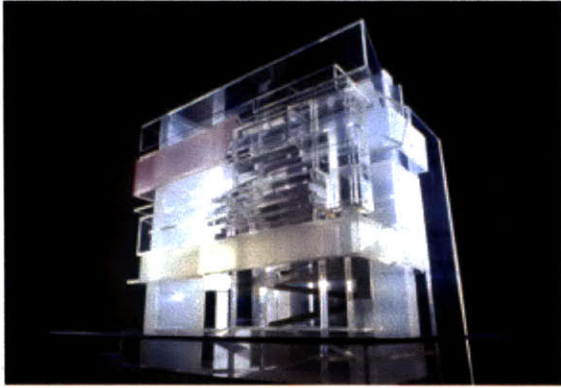

Zaha Hadid



Smith, Miller + Hawkinson

what to do with them? In the above example, OMA chose to insert a foreign infrastructure, the grid, which purported to offer the greatest flexibility and diversity. In her Cincinnati Art Museum project, Zaha Hadid manipulated the tissue of a gallery sequence to accommodate an extension of the sidewalk into and throughout the museum. By encouraging a synthesis of the museum with the life of the street, she softened the boundaries of the institution. In their submission to the “Big Shoulders Small Schools” competition in Chicago, SMH (Smith, Miller + Hawkinson) stacked classrooms into linear blocks which allowed them to selectively define the perimeter of a school in relation to the surrounding urban blocks and transportation nodes. The perceived need for the security of an enclosed “schoolyard” was married with the specific urban needs of the site. Both of the above examples

manipulate existing programmatic tissues in ways that support meaningful integrations of the proposals into their contexts.

In this project, I approached the problem of a health center in a small American city from both opposing positions of global and local, generic and specific, strategy and tactic. Such an approach first requires a thorough understanding of the tissue to be manipulated, as well as the specific conditions of site and context. The health care tissue I have examined can be roughly divided into two classes: physical tissue and experiential tissue. The physical tissue is the history and analysis of the formal language of health care. The experiential tissue is the sequence of events, activities, emotions, and velocities of the patient in his or her encounters with doctors, nurses, and the various forms of health care infrastructures at large.

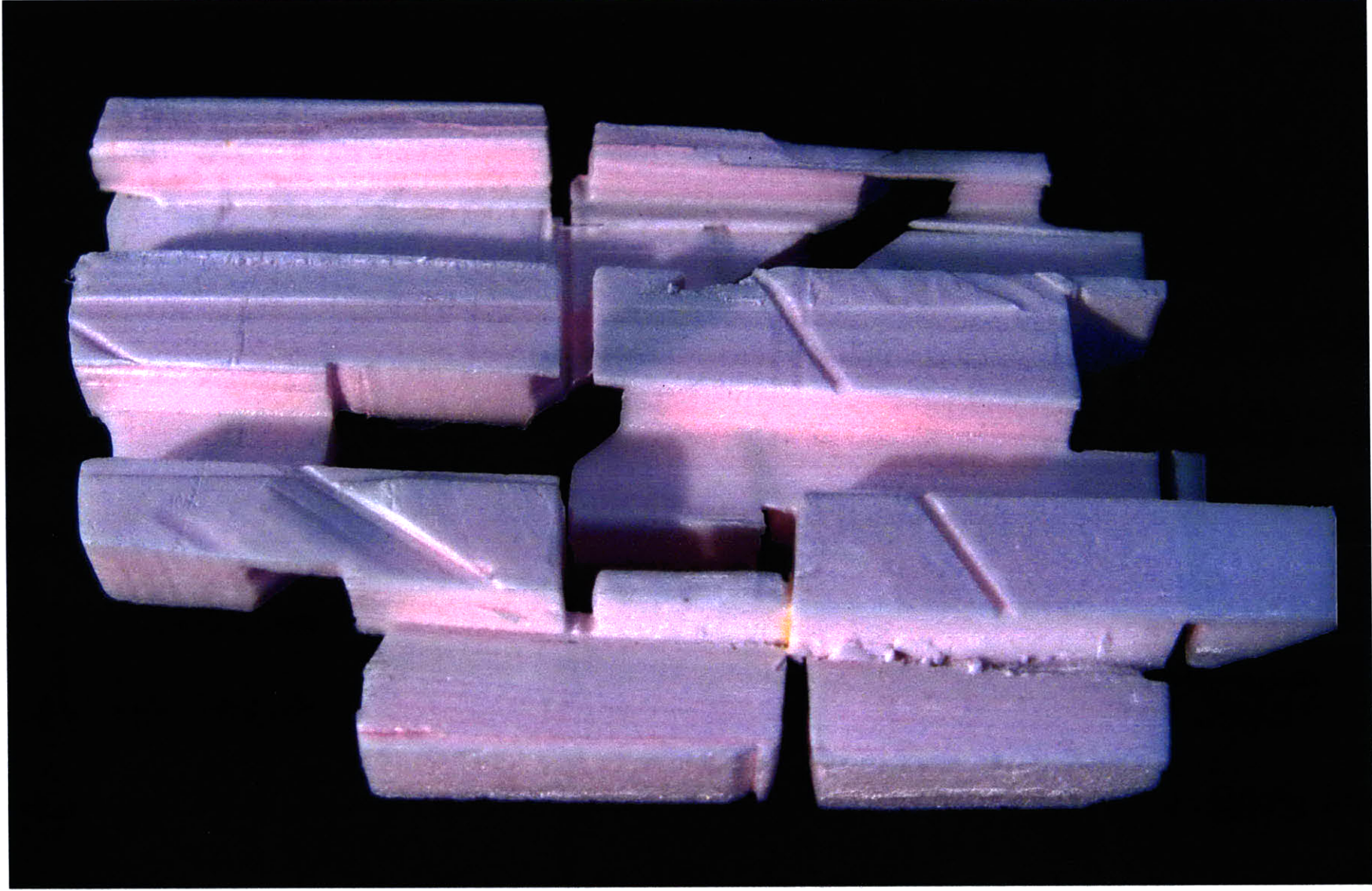

# physical tissue

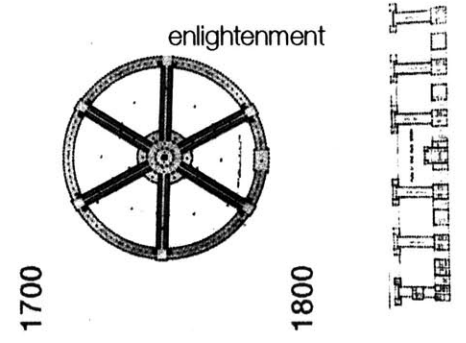



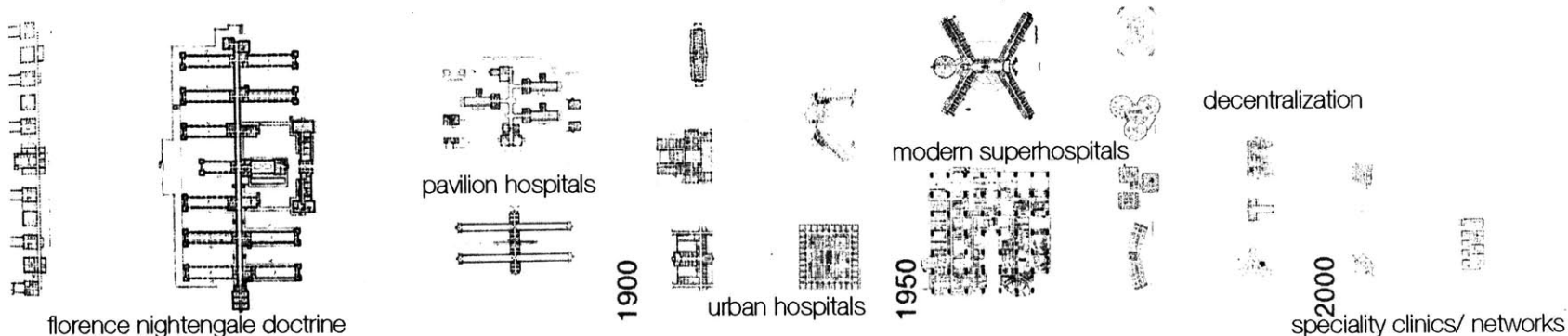

"The disciplinary space is always, basically, cellular" - Michel Foucault, Discipline and Punish.

Despite the shared constraints and similar requirements of healthcare worldwide, the facilities show a surprising range of sizes, shapes, and organizations. The inability to sufficiently cope with constraint has been manifest in a array of earnest attempts, false starts, and spectacular failures which are difficult to link together into a cohesive temporal lineage. The canon of health-care architecture has yet to be written (and it is certainly beyond my scope to consider it here). But there is one broadly legible shift in the spatial character of hospitals. In the 1870s while working with the disease chicken cholera, Louis Pasteur formulated the

hypothesis that a disease could be linked to a specific microorganism; and furthermore, that these microorganisms could move through bodily fluids or through the air. Germ theory along with the distinctly modern desire for personal privacy were the death knell of the large common ward of the 18<sup>th</sup> and 19<sup>th</sup> century. Pavilion hospitals such as the Moses Taylor Hospital in Pennsylvania, that were part of a hospital building tradition dating back to the earliest hospitals in medieval French monasteries, gave way to modern hospital blocks. The ironic production of diversity through limitation continues to the present day. Given the multiplicity of hospital and clinic types, why do the healthcare buildings of today always feel the same? The answer is that they are composed of the same basic spatial tissue. A tissue which

THE MOSES TAYLOR HOSPITAL . SCRANTON . PENNSYLVANIA . U . S . A .  
 SCALE OF 0 10 20 30 40 50 60 70 80 90 100 110 120 130 140 150 160 170 180 190 200 210 220 FEET

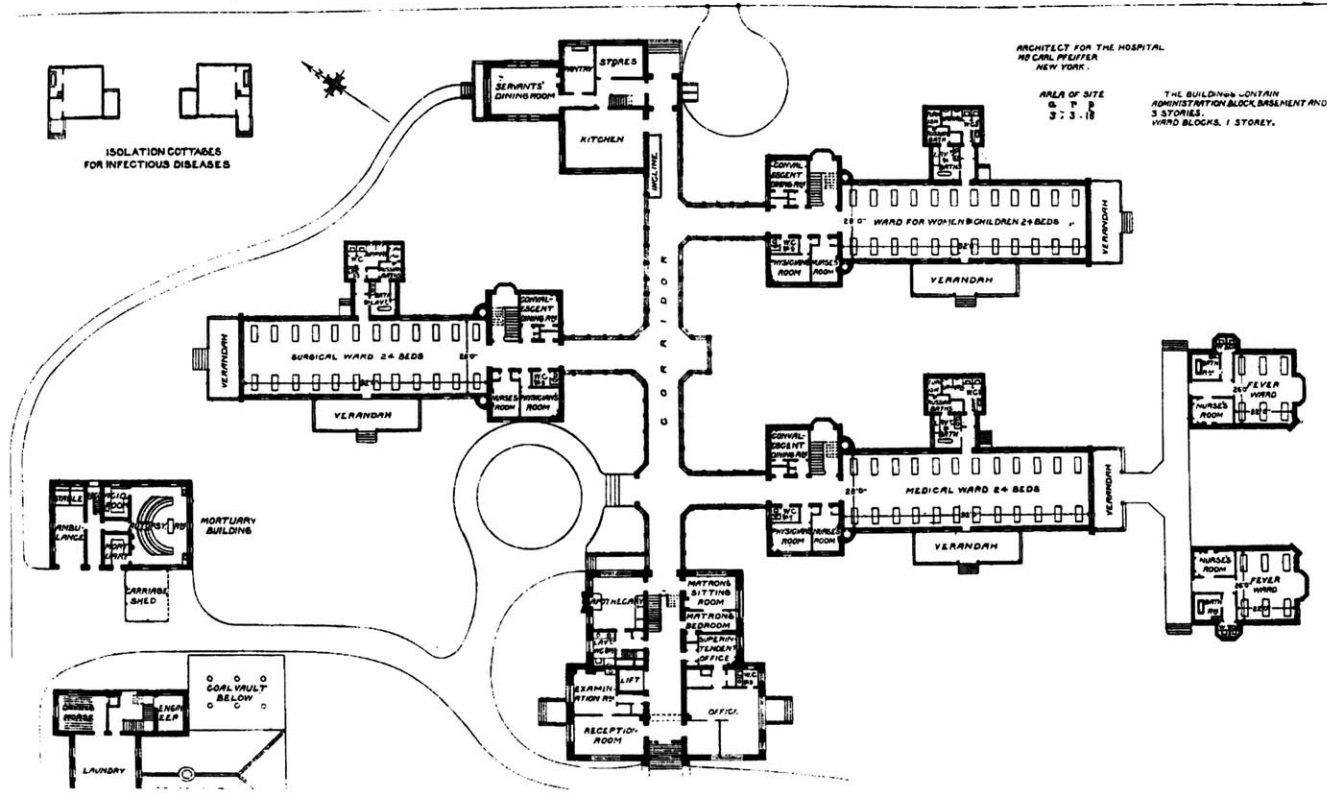
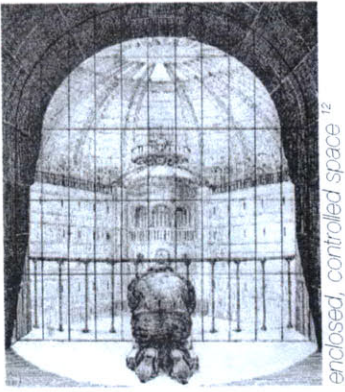

Fig. 172. Plan of Moses Taylor Hospital, Scranton, Pa.

*open pavilion wards, pre-germ theory."*



adheres to Foucault's conception of the "disciplinary environment."

Foucault included hospitals under the umbrella of the disciplinary environments because they are infrastructure which support the control and/or manipulation of many by a few. But it was primarily in his study of prisons that Foucault demarcated the three spatial characteristics of a disciplinary environment.

These are:

- (1) A disciplinary environment is enclosed and inward looking.
- (2) The methods of spatial control are predominately visual.
- (3) A disciplinary environment is cellular, diffuse, and partitioned into choreographed, easily controlled spaces .

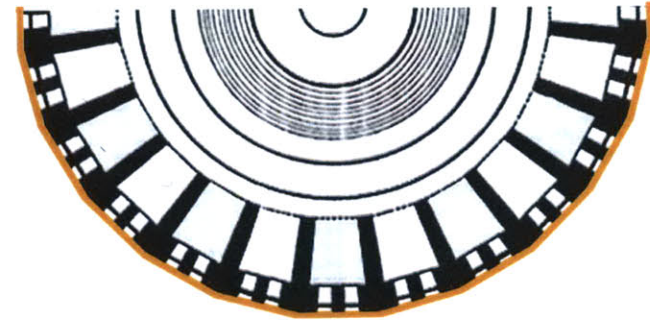

enclosure

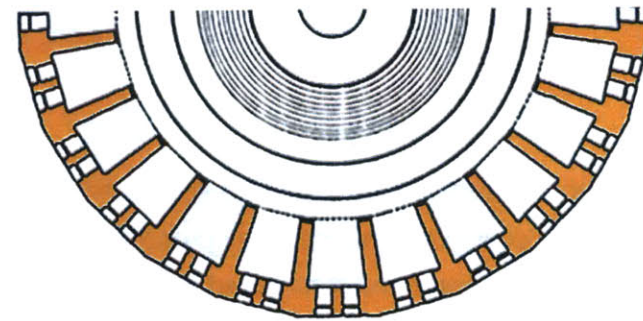

partitioning

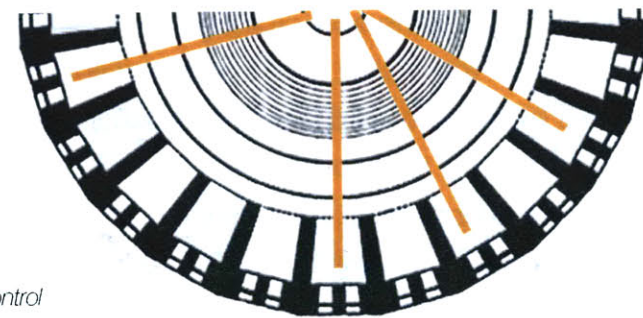

visual control

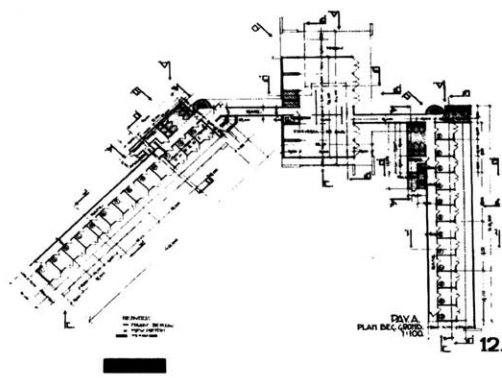

Jan Duiker's tuberculosis sanatorium - an anomalous programmatic need for daylight provides the rare opportunity for the modern transparency cult to infiltrate the hospital



"sun therapy"<sup>14</sup>

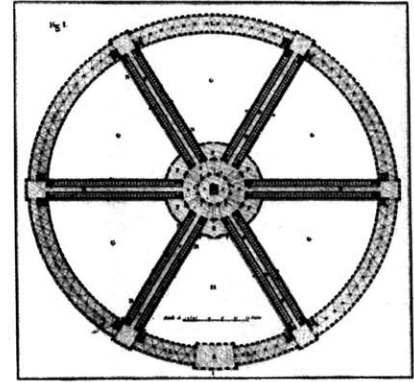

La Chapelle

### Enclosure

For most of the hospital's history, it has eschewed both the urban *and* the out of doors. The monastic precedents of the hospital, among other factors, have contributed to this isolation. In the 18th century, the French government built the first wholly secular hospitals which were described as "communal houses of the sick," thereby serving as devices for protecting the healthy from the sick, the sick from the healthy, and, to some extent, the sick from themselves (in separate wards for each disease). The envelope of the hospital was a threshold between the indoor world of the sick and the outdoor world of the healthy. I believe that this basic notion of separation remains to this day, perhaps reinforced by the mechanization of modern medicine and the cult of "healthy living."

Tuberculosis sanatoriums are one notable exception to the rule of enclosure. In the late nineteenth century, nurses found that exposure to sunlight hastened the recovery of TB patients and prevented the infections of others. As a result, an alternative type of rural sanatorium was born. Jan Duiker's Zonnestraal sanatorium at Utrecht of 1926 is a late example of this anomalous trend. The building included continuous glazed balconies connecting every patient room.

### Control

Visual control predominated both in the premodern hospital environment and in the clinical culture of the day. Like the prison, the enlightenment hospital was an environment characterized by institutional control and the privilege of visibility. The open ward

disease registered as "sign" -  
medical visibility was reflected in  
spatial visibility<sup>8</sup>

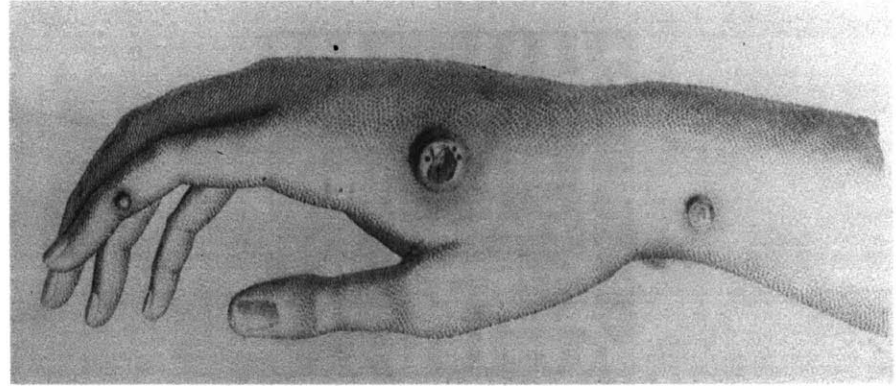

was laid out to be always under the administrative gaze. Huge radial hospitals, not unlike the panopticon, were proposed by French architects. And the radial form survives in many inpatient blocks to this day. This visibility was also tied to the practice of medicine in the 18<sup>th</sup> century. A doctor, after all, could not put his ear to the chest of a female patient. Doctors were taught to “read” the symptoms displayed on the body and classify the pathogen by its tell tale signs.

### Partitioning

It was only in the nineteenth century that medicine shifted from an interpretive, visually-based mode of diagnosis to a analytical, sensory mode of diagnosis thanks to the stethoscope and the

dissection of cadavers. The body was then understood as a collection of overlaid parts and systems the functions of which could be divined by touching them, listening to them, and manipulating them. This new understanding, combined with the advent of germ theory, gave rise to the modern hospital—a strictly constructed environment of pathological discipline. Space is ruthlessly partitioned to demarcate the domains of specific bodily systems. Air is rigorously controlled, filtered, and recirculated. The section is equally divided into interval of mechanical support and occupation. The space of the doctor, the nurse, the patient coagulate into strict hierarchies. And doctor and patient meet in the exam room, a tight, enclosed space of palpitation and bodily manipulation.



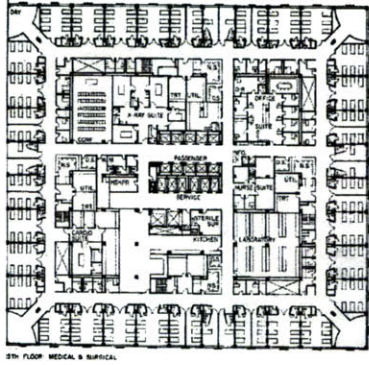

Bellevue Hospital, New York 1964 - characteristic volumetric taughtness, partitioning, and controlled circulation

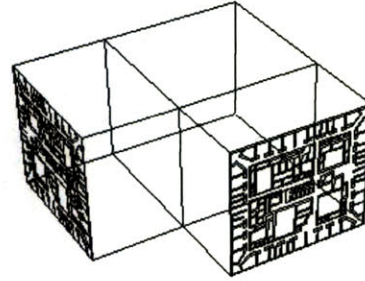

bidirectional extrusion

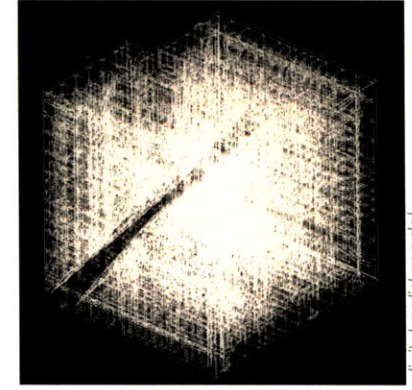

digital solid model

## Cellular Spaces

The partitioning common to modern healthcare space creates cellular spatial systems. Rooms aggregate into labyrinthine clusters wherein one moves from one space to another with little transition or hierarchy. Like veins, the hallways and double-loaded corridors interrupt and feed the cells, providing the only heirarchy in the system. Otherwise the spaces are all similar in scale and finish. And the thresholds between the spaces are nearly identical doors differentiated only by signage.

I asked the question, "Can this cellular structure be radicalized to the hospital's advantage?" Can cellularity be a strategy in plan and section, such that rooms begin to function more like cells in the body; absorbing information and resources from all

directions and forming links in mechanical networks?

For this investigation, I chose a hospital that exemplifies the generic cellularity common to mid-century urban hospitals: The Bellevue Hospital in New York. I drew the plan of a typical floor of the hospital and then extruded this plan in two directions. The resulting solids were overlapped and bisected to see the types of spaces and interrelations that resulted. The 3D resultant was cut along carefully chosen vectors and printed by stereolithography.



stereolithography model

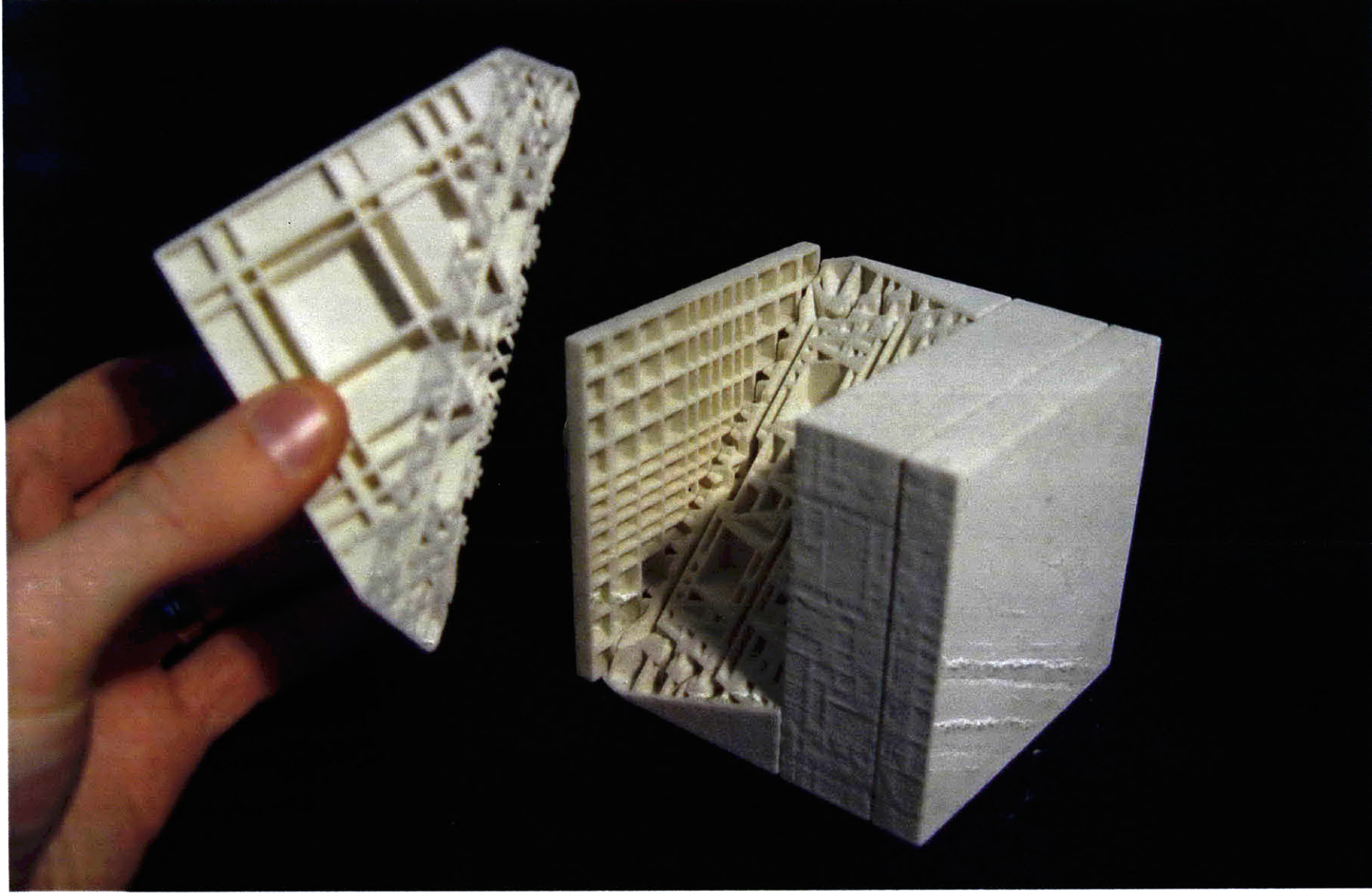

stereolithography model



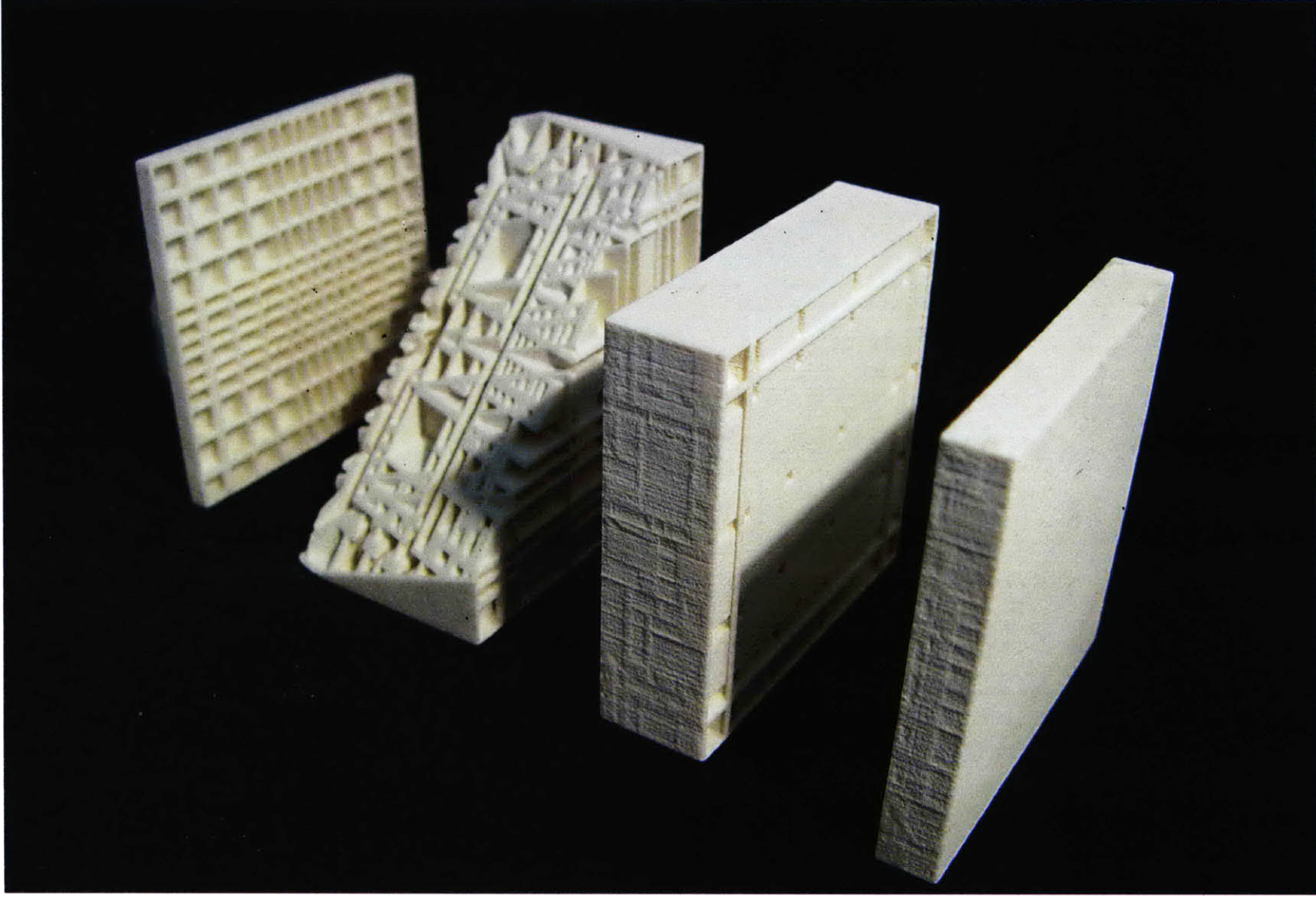

stereolithography model





*adjacent hallways in South Coast Hospital, Dana Point, California*

### Alternatives

The modern hospital collapsed under the weight of its own complexity. The death of the hospital has been widely proclaimed from as early the 1960s. For the patient, the experience was dehumanizing. For the administrator the closed environment was inflexible. The only mechanism of growth or change was the tacking on of another closed environment to the first. Confusing aggregate hospital complexes resulted such as the Massachusetts General Hospital. But the alternatives are unclear. Attempts to mitigate the dehumanizing effect of the institution with carpeting, chair rails, and pastel paint colors only amount to wallpapering over the existing spatial topology. And the accelerated rates of technological change and mechanical demands promise only more architectural ad-hocism in the future.



*implosion of outmoded hospital*

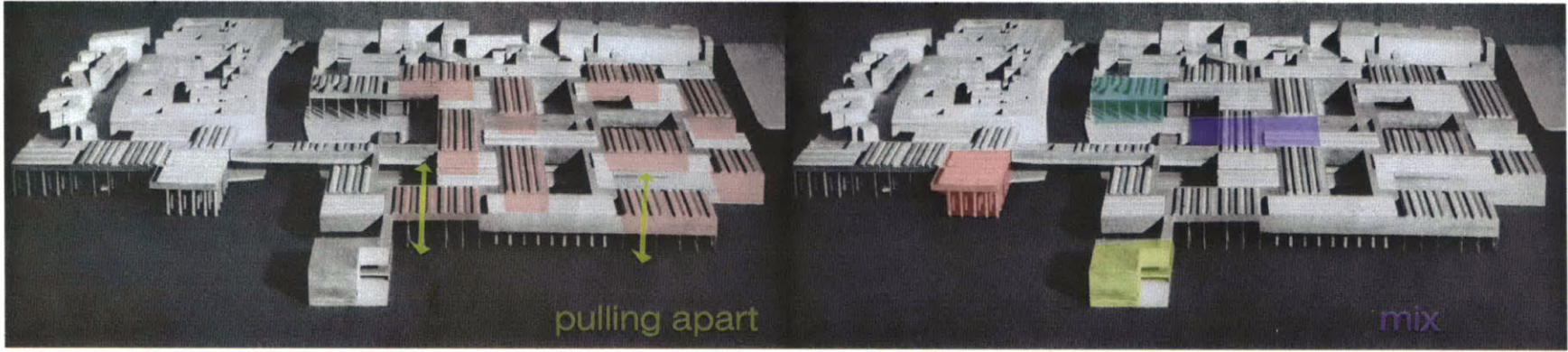

Le Corbusier's Hospital of Venice was both a subtle alternative to and economic casualty of the shift away from the superhospital. The project, one of the last designed by Corbusier before his death in August 1965, was never built. But this project teaches interesting lessons about mechanisms for tactically engaging civic structure and the urban life around the institution. This hospital is fragmented into smaller sub-hospitals that are organized vertically. These subhospitals are pulled apart to allow the urban structures of promenades and plazas to invade the hospital. The mat superstructure accomadates a complex mix of uses and modes of circulation. Ultimately, these strategies are still valuable signpost for today's clinics and hospitals.

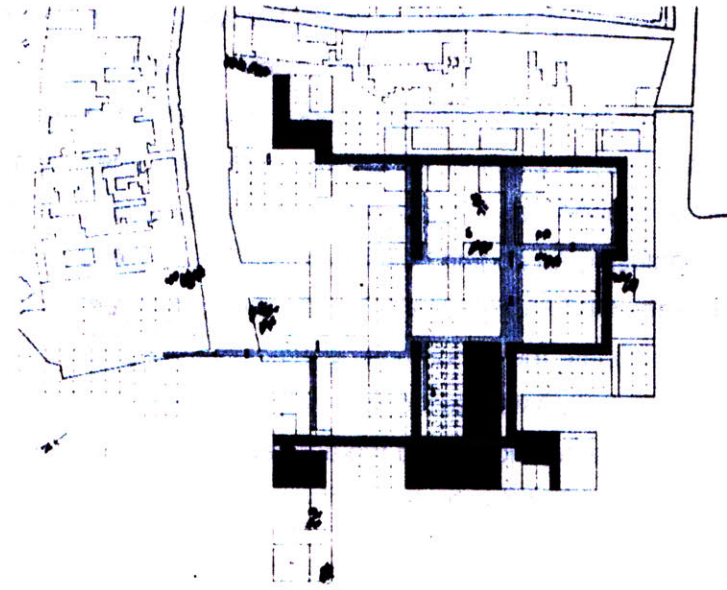

Hospital of Venice, plan



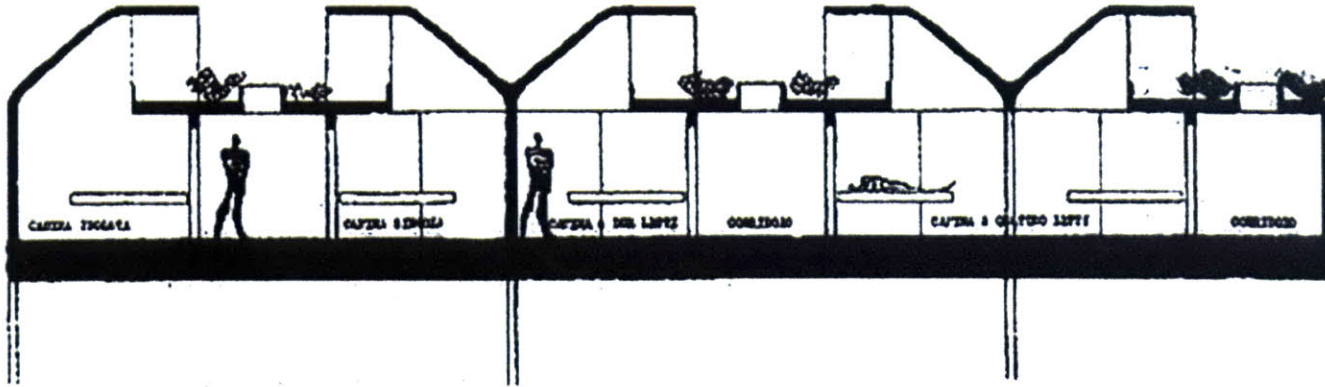
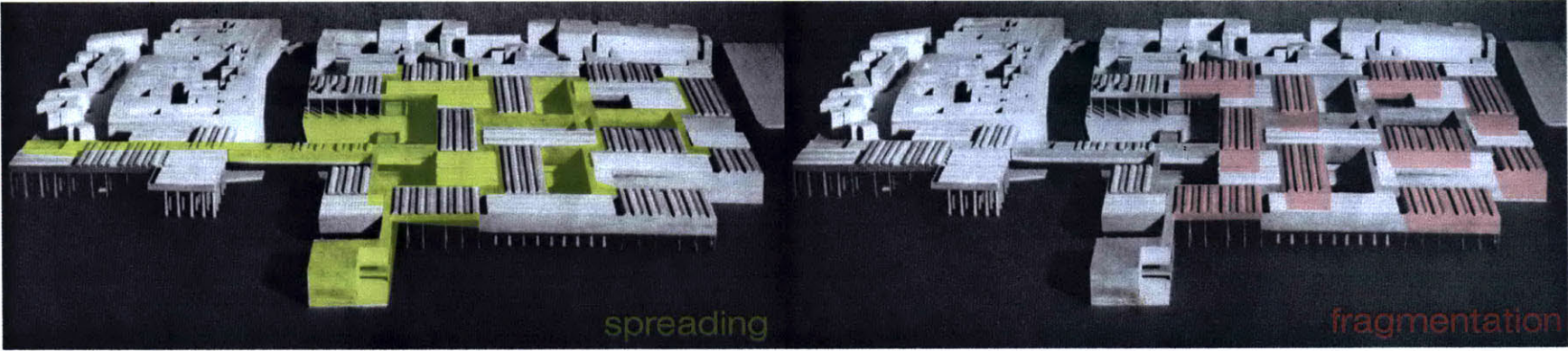



## Decentralization

Programmatically, the neighborhood clinic was proffered as an alternative to the hospital (or at least a substantial substitute). Finsbury Health Clinic in England, the first of its kind, was built in 1938. Though more orderly than the hospital, the clinic sacrificed the technical resources. It was still planned as a closed environment, resistant to change. And in practice the clinic became more like a gatekeeper to the services of the hospital—another mechanism of control.

At present, the health care delivery complex is again being reinvented due to issues of management and technology. Technology has shifted the medical diagnostics back to the visual

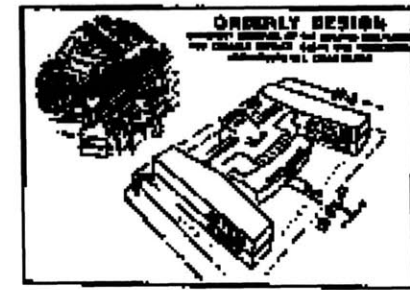

privilege of the enlightenment. Why listen to the heart when a CT scan can show you the structure of the failing aorta? The tactile connection is now not between the patient and her doctor but between the patient and the diagnostic tools of her environment. Healthcare management is privatizing and decentralizing. Small organizations are competing for patients. The patient as customer now enforces a level of control over the healthcare provider. The disciplinary environment is now subject to market discipline. Therefore, the old power structure of the enclosed environment must be reversed. We need an extroverted model of clinic where the patient has visual control of the space and connection to the outside. A new healthcare center must be an inherently open, non-disciplinary environment.



## Subjectivity

“To each movement are assigned a direction, an aptitude, a duration; their order of succession is prescribed. Time penetrates the body and with it all the meticulous controls of power.”- Michel Foucault, Discipline and Punish

Experience is inherently subjective. Literature and cinema are rife with descriptions and imagery of healthcare environments. We all have a feeling for the space of the clinic.

I was interested in the rhythms, cadences, and textures of the healthcare experience. What are the circadian rhythms of our shadowy pathological lives? How do our collective pathological

lives overlap with our normal lives? To this end I undertook a series of discussions with people about their lives spent in and out of the medical institutions. These interviews in turn led a mapping of these individuals' paths through the health care system. This graphic explorations in the form of networked medical history charts created room for unique speculations on the experiential tissue of the health care institution.

## experiential tissue

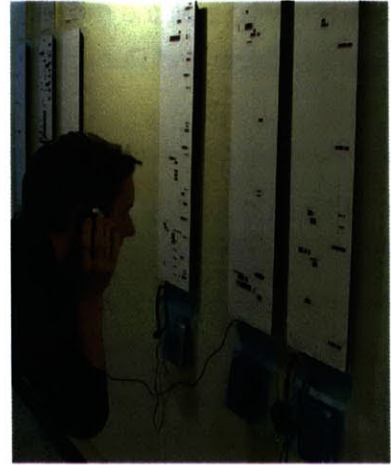

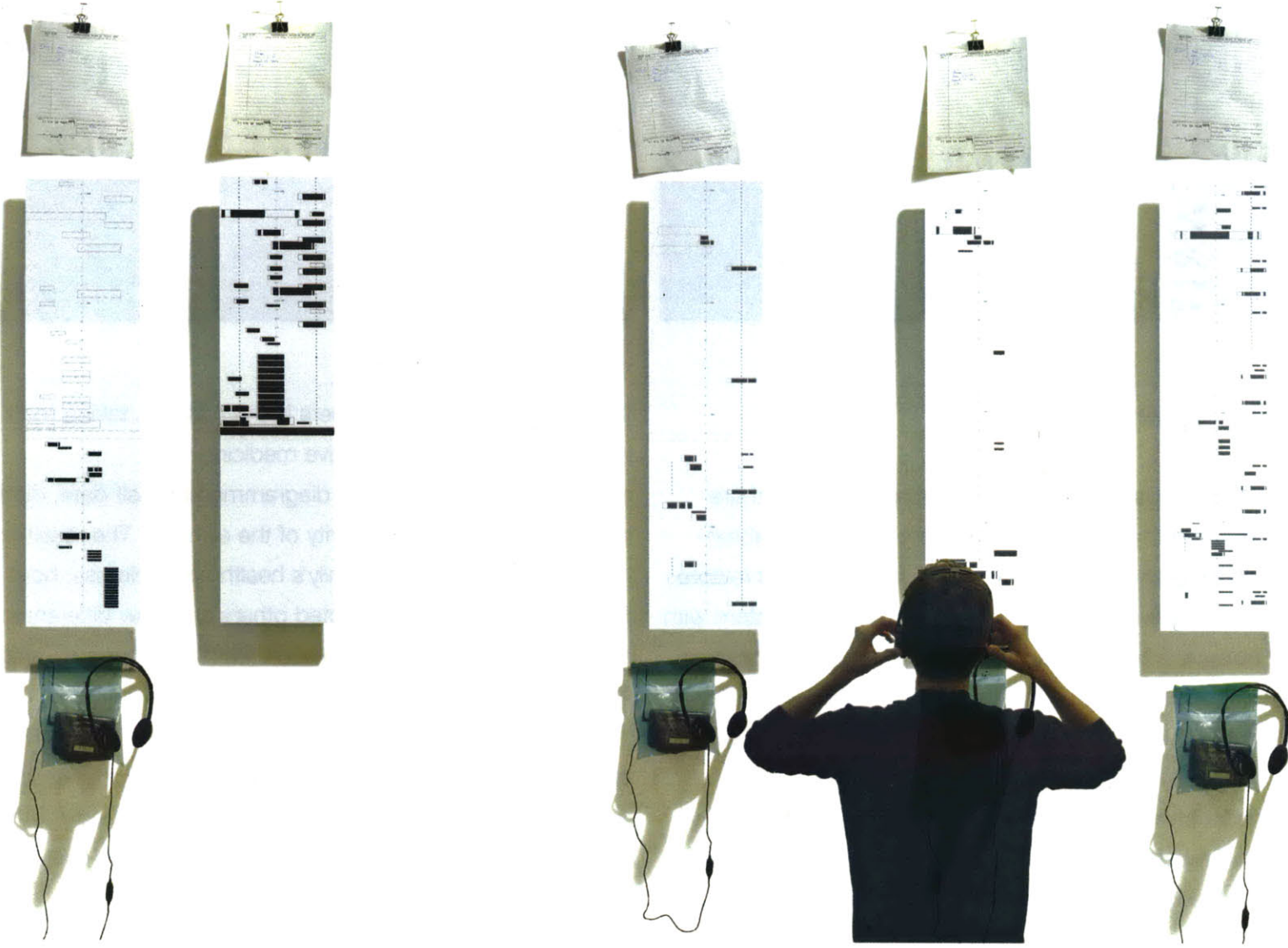

*recorded interviews with family members,  
interpretive diagrams,  
medical histories*



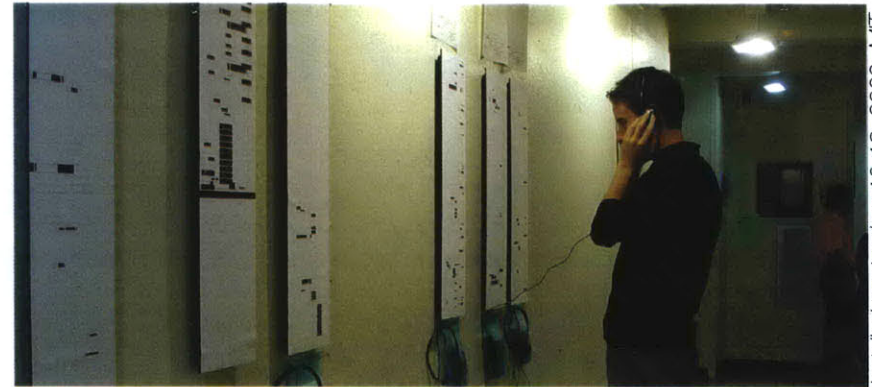

installed september 13-18, 2003 MIT

## Familial Pathologies

The traditional positivist medical institutions hold that there exists an ideal, healthy body. The role of the medical establishment is to observe and identify the pathological body and restore it to the ideal. However, everyone moves through this system with a different body, a different ideal, and differing degrees of engagement, ambivalence, or alarm. The notions of normal and pathological are subjective and are often defined and challenged within the family unit.

This installation included five recorded interviews with family members that traced all of their interactions with the health care system over a period of three years—including regular checkups,

emergency care, visiting others in the hospital, taking medications, and any forays into alternative medicine.

These interactions were diagrammed by visit date, duration, activity, place, and the severity of the ailment. The result was an engaging portrait of one family's health and sickness; how one family member's health affected others and how different ages and attitudes towards the body affected the frequency and severity of one's visits to the clinic or hospital.

Also, the interviews and diagrams clearly show the importance of the experience of waiting. Waiting consumes almost half of one's time in the system. And how one perceives that waiting experience strongly affects how one perceives the overall quality of treatment received.



Time

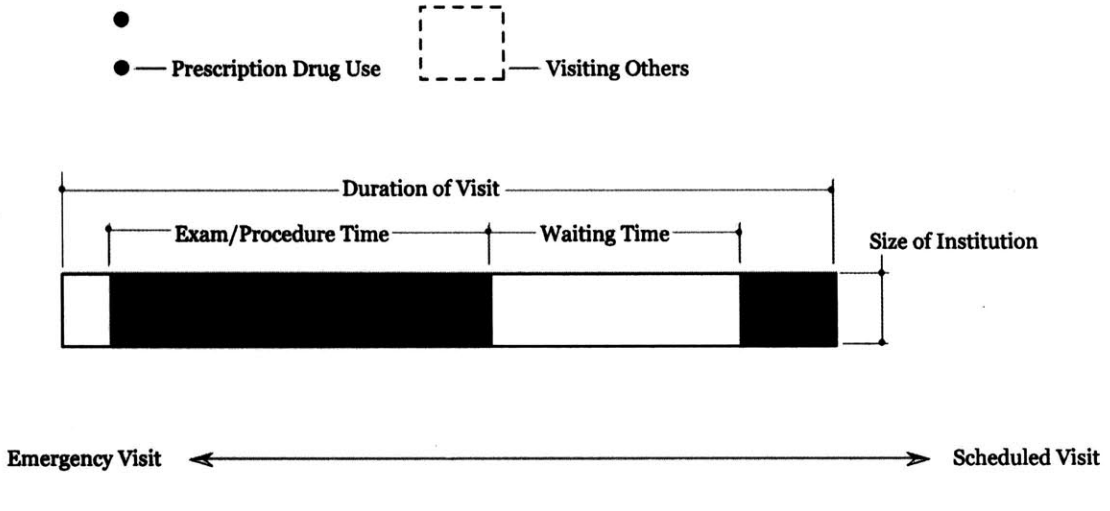

## Mapping Waiting

I produced a waiting map that traced a day in the life of a clinic, as patients moved back and forth through waiting spaces and care spaces.



waiting room, los angeles

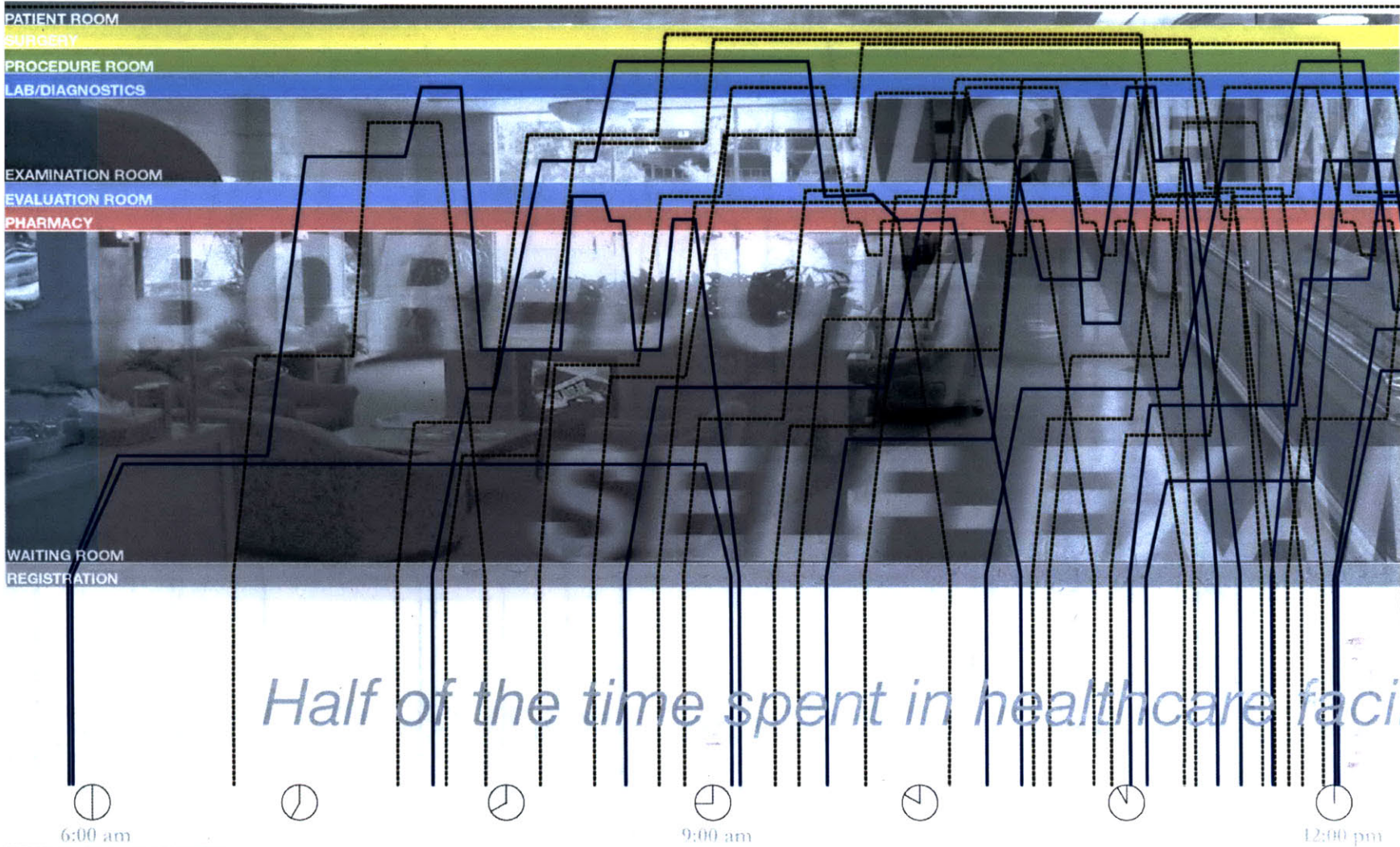

*Half of the time spent in healthcare facilities*

**CLINIC VISITS IN ONE DAY**  
 - - - - - EMERGENCY  
 ————— SCHEDULED



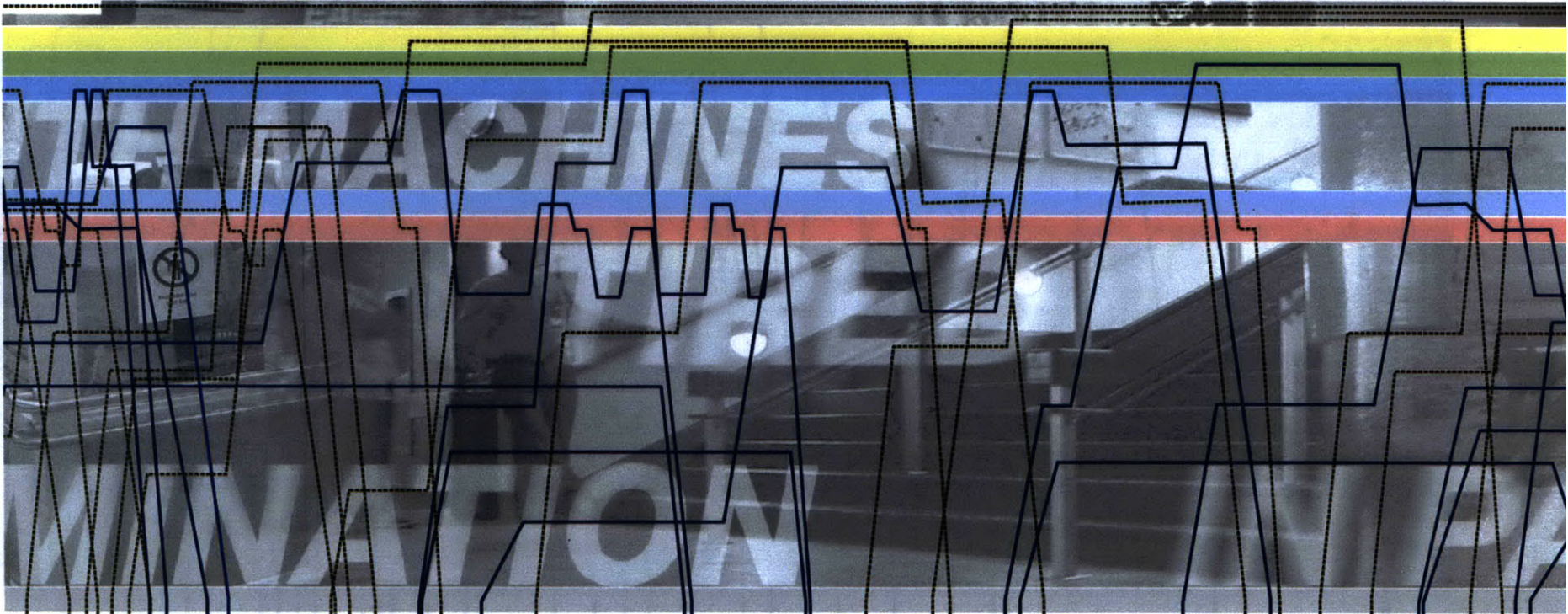

*ilities is spent outside the exam room, moving betw*



6:00 pm



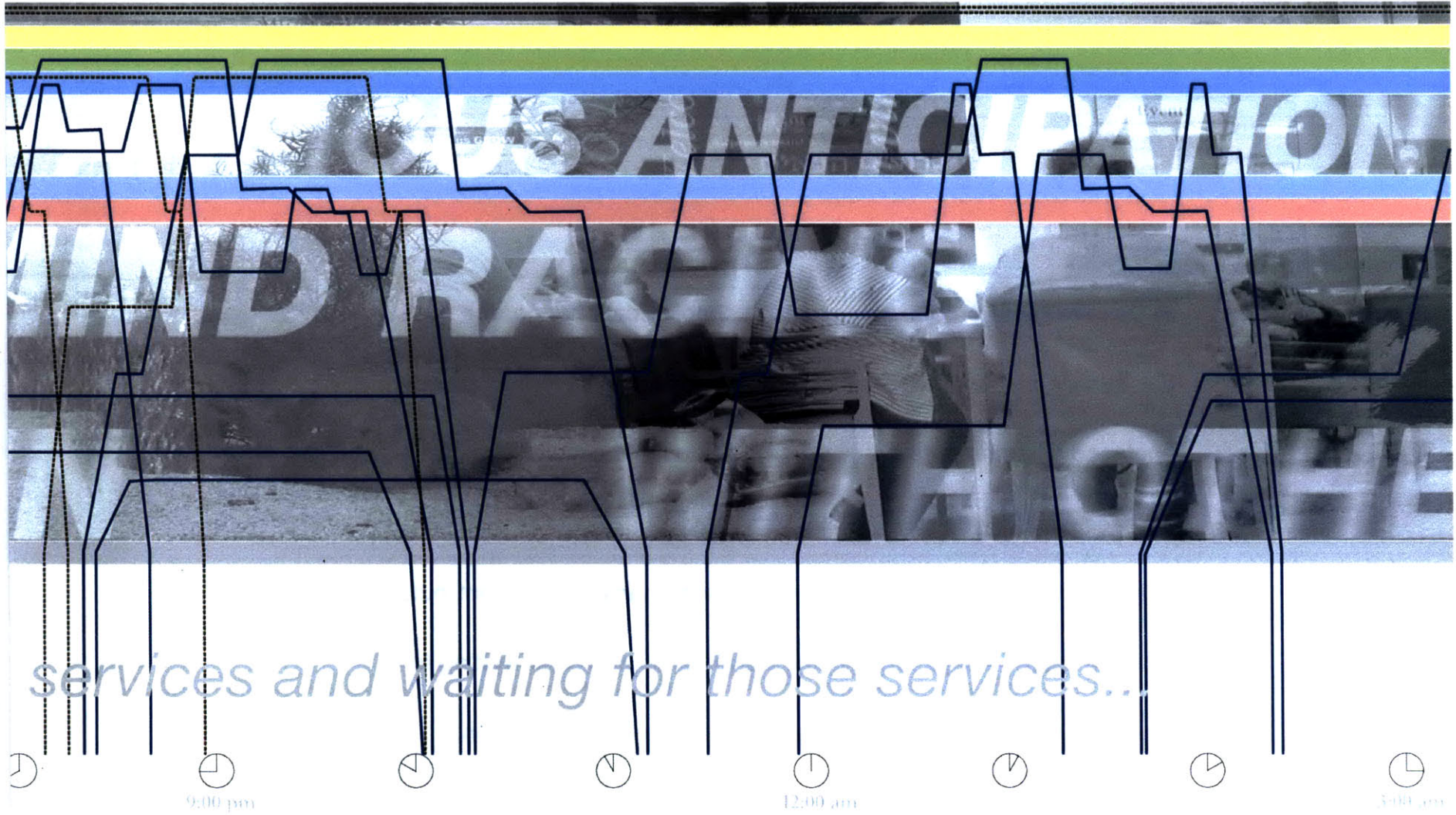

*services and waiting for those services...*

## **conclusions**

- 1) Despite rapid organizational and technological change, the spatial quality of hospitals and clinics has been unwavering: strictly enclosed environments ruthlessly partitioned into cellular structures and accessed by double-loaded corridors.
- 2) Nearly half of the time spent in healthcare facilities is spent outside the exam room, spent moving between services and waiting for these services. The clinic has become a space of anticipation.

## **thesis**

I propose that this space of anticipation be consolidated, reorganized, and leveraged as a means to pull apart the tissue of the clinic. Reconceptualizing and reconfiguring medical waiting rooms in relation to circulation, context, and clinical space can catalyze a loosening of the traditionally closed clinical environment and its integration into the physical fabric and social life of the city.

# presentation





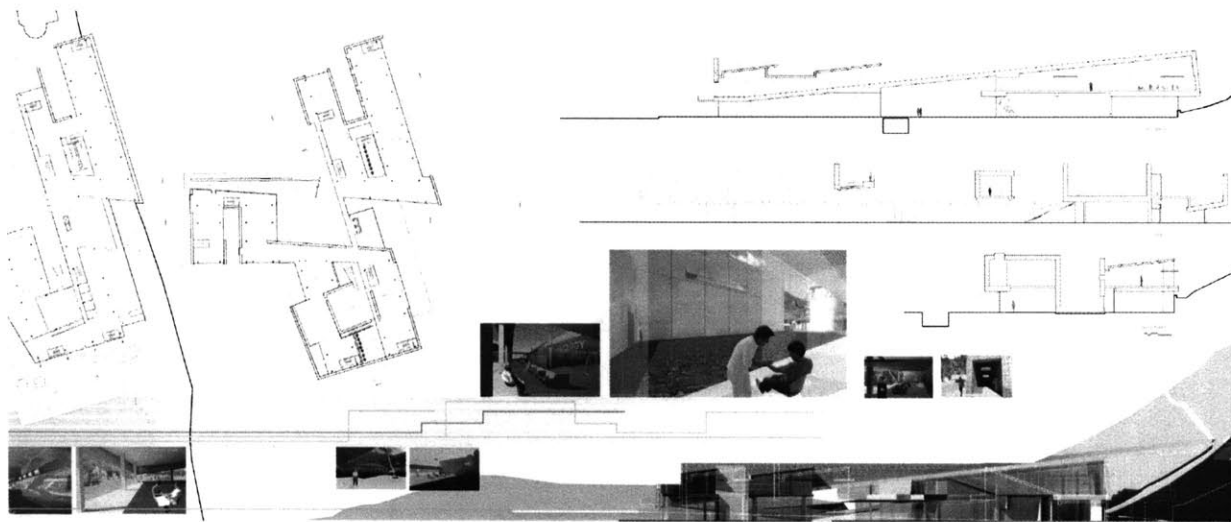

**Introduction**

6 .....Introduction

18 .....Physical Tissue

32 .....Experiencial Tissue

**table of contents**

44 .....

**Site Analysis**

46 .....Urban

50 .....Medical

**Strategies**

52 .....Primary

58 .....Secondary

**Tactics**

62 .....Pulling Apart

64 .....Crossing Over

66 .....Systems Integrations

68 .....Privacy Gradient

70 .....Waiting Infrastructure



**Paths**

74 .....*doyenne*



80 .....vacationers



90 .....working mother



98 .....hiker

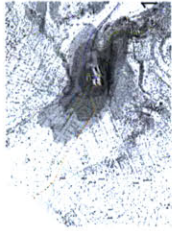

**Drawings**

104 .....site plan

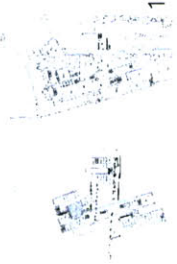

105 .....plan

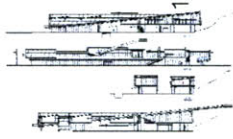

106 .....sections

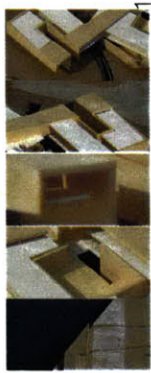

**Models**

108 .....study 1" = 32"



110 .....study 1" = 16'

## site analysis

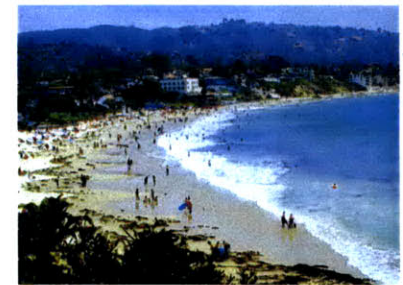



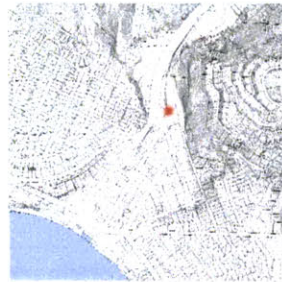

## Laguna Beach, California

Along the the Orange County coast, about one and a half hours south of Los Angeles is the town of Laguna Beach, long recognized as a healthful retreat from the inland empire. The average daily population is an eclectic mix of beachgoers, rich homesteaders, retirees, and migrant workers.

The site lies at the mouth of Laguna Beach canyon, where the grid of the small downtown emerges from the canyon. The site is bracketed by steep hillsides and cut in half by the concrete wash that controls the river. One of the hillsides is undeveloped open space that is contiguous with a larger network of trails and open space. A stand of eucalyptus provides shade that is rare in this part of southern California.

Presently, the site is occupied by parking for both the adjacent city hall and the adjacent Festival of the Arts, a popular summer destination.



*Parking and industrial ruins*



*eucalyptus stand*







commercial



civic



residential

### Urban Structures

The site sits along a chain of civic buildings from the high school through the city hall to the festival pavilions in the canyon. On the opposing axis the site sits at the head of the commercial triangle of the downtown. The site is poised in good walking distance from a large number of residential properties, and the town's bus station is one block away.

### Land Forms

The mouth of the canyon has clear implication for the directionality of wind and water moving through the site. The site sits high enough that there are views of the ocean from third story windows. And the connection to open space trails reveals the possibilities for more urban connectivity through the site.

### Cultural Oddities

Laguna Beach is one the only places in southern California that is walkable. The commercial properties downtown take advantage of this traffic with open air mall-type spaces that support a number of types of small business and boutiques, including beauty salons, tanning beds, and art galleries.

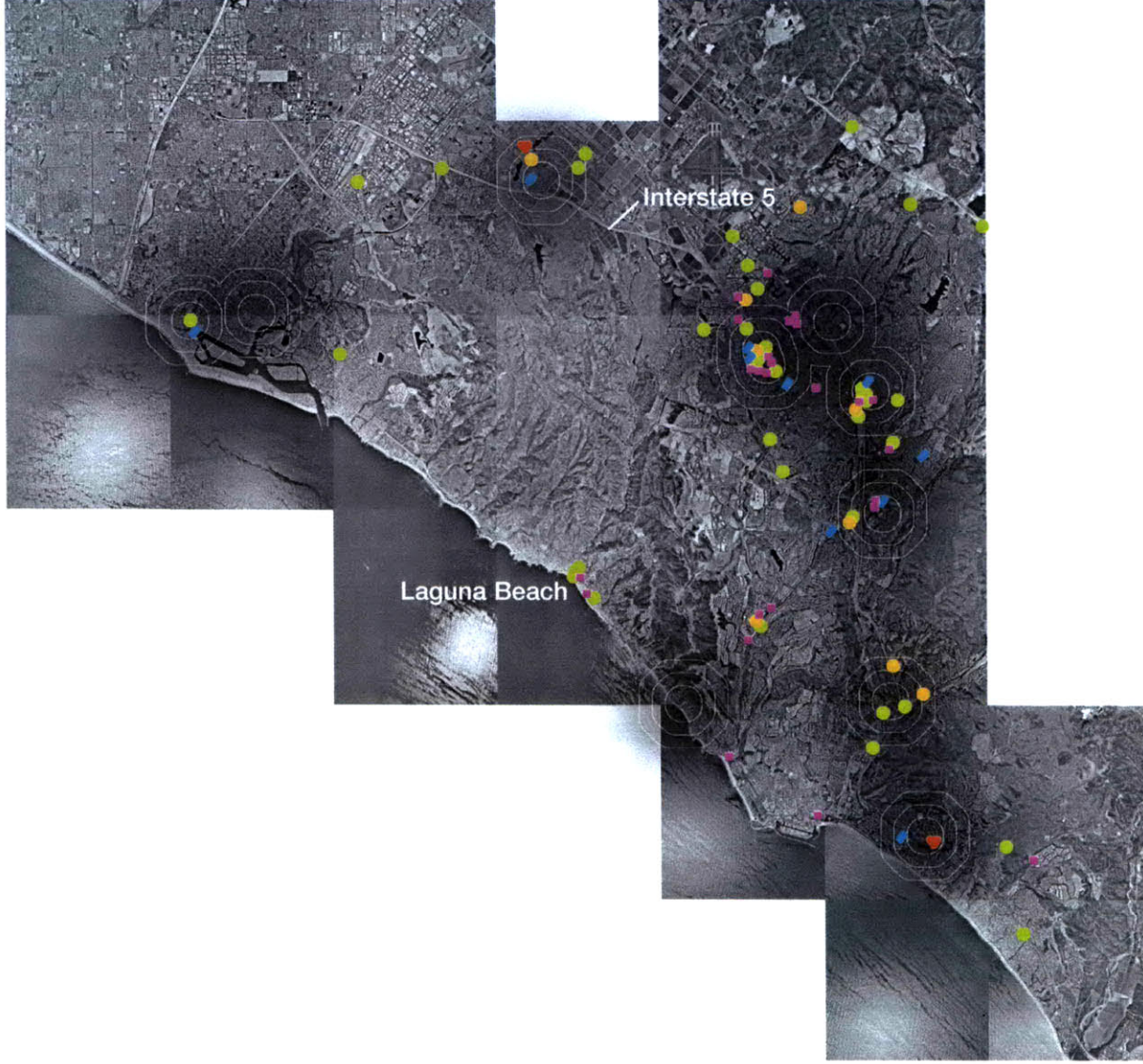

Map of medical resources in Orange County:  
-White rings indicate hospital wards  
-Colored shapes are different types of support services





South Coast Medical Center



### Medical Landscape

A map of the the medical institutions around the town of Laguna Beach shows that services are clustered along the corridor of the interstate about 20 miles inland. Large hospitals serve as the hubs of large networks of smaller clinics and services. However, Laguna Beach is isolated and underserved.

The nearest facility with any real services beyond basic care is the South Coast Medical Center about 8 miles south of downtown. Discussion with administrators at the hospital revealed that, while their number of inpatients was down, utilization of their imaging and laboratory capabilities was up. Technical resources attracted doctors and referrals. But their isolated location cut down of their potential market.

## primary strategy









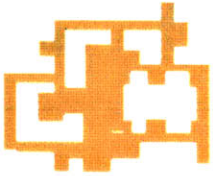

### Programming

Previous studies of healthcare buildings by Valins have diagrammed public (circulation and waiting) versus private spaces (care spaces). The diagrams on the right are adapted from these studies.

Interestingly, the program areas devoted to public space and those devoted to care seem nearly equal in size. But clearly, the relationships of public and private were not strategized in a coherent or meaningful way.

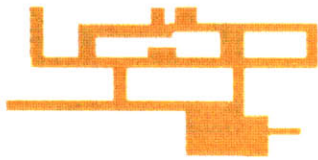
Rather than propose a strategy of public versus private, I propose to strategize the program in term of three areas: circulation, waiting spaces, and care.

| CIRCULATION/ WAITING SPACES  | CARE SPACES   |
|--|---|
|    |    |
|   |    |
|    |    |
|  |  |

massing diagrams of public and private space

NETWORK CARE



NETWORK CIRCULATION

DIFFUSE CARE



NETWORK WAITING

LINEAR CARE



DIFFUSE CIRCULATION



DIFFUSE WAITING

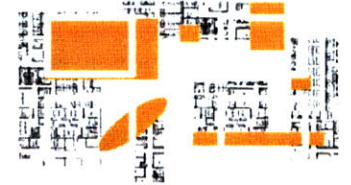

LINEAR CIRCULATION



LINEAR WAITING

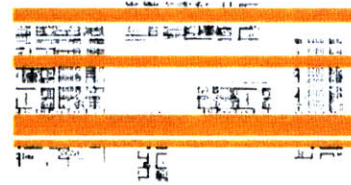



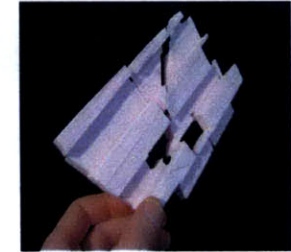
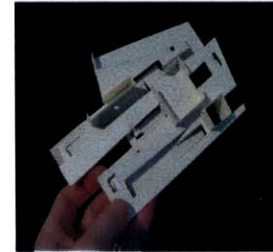

## Overlaid Organizations

Three potential modes of organization of any programmatic element are (1) network organization, (2) linear organization, and (3) diffuse organization. A network organization overlaps similar program elements creating a continuous interwoven tissue. A linear organization establishes isolated directional zones which extend to the exterior boundaries thereby imparting a grain to the system. A diffuse organization separates programs into discrete and independent zones.

I applied these three organization to my three programmatic divisions and overlapped the various results.

After some consideration, I decided that the most fruitful combination might be linear care, linear circulation, and networked waiting. The circulation generates a grain in the system and efficiently supports and differentiates various zones of care spaces. The waiting space

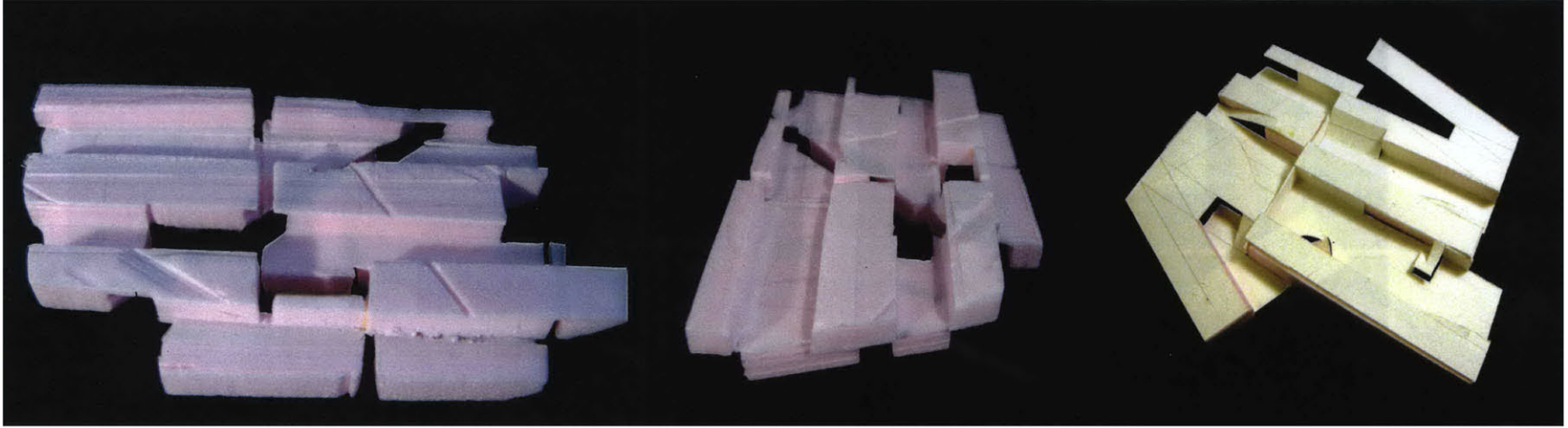

become the anomalies, a overlaid system which intersects the care in a targetted, cross-grain fashion and engenders an alternate low-velocity circulation space. Furthermore, the grain could flip in section providing an opportunity for mechanical systems to weave through the structure.

### **The Mat Building**

The establishment of a dominant diagram began a generalized investigation into the making of a mat building and the making of a mat building that conforms sensitively to a complicated, difficult site. A series of study models ensued that attempted to find the middle ground between mat and the figure, between object and texture.

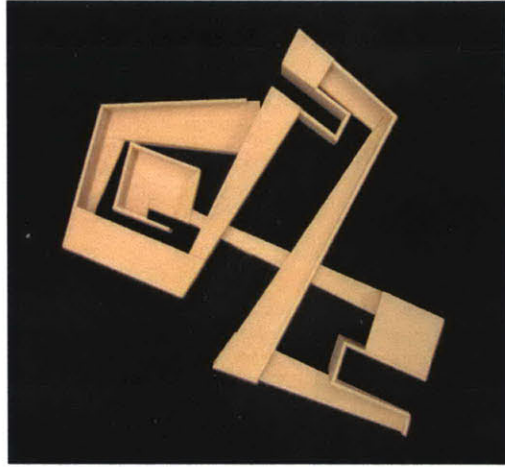
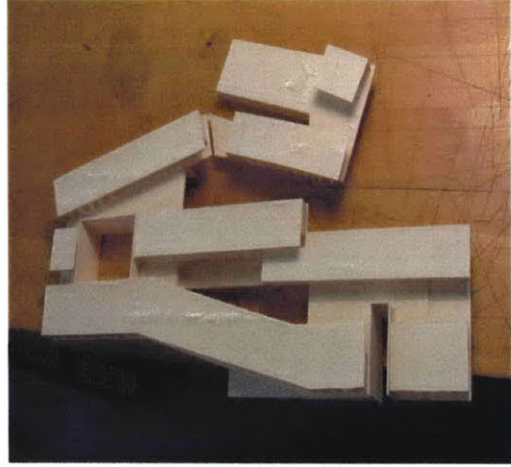
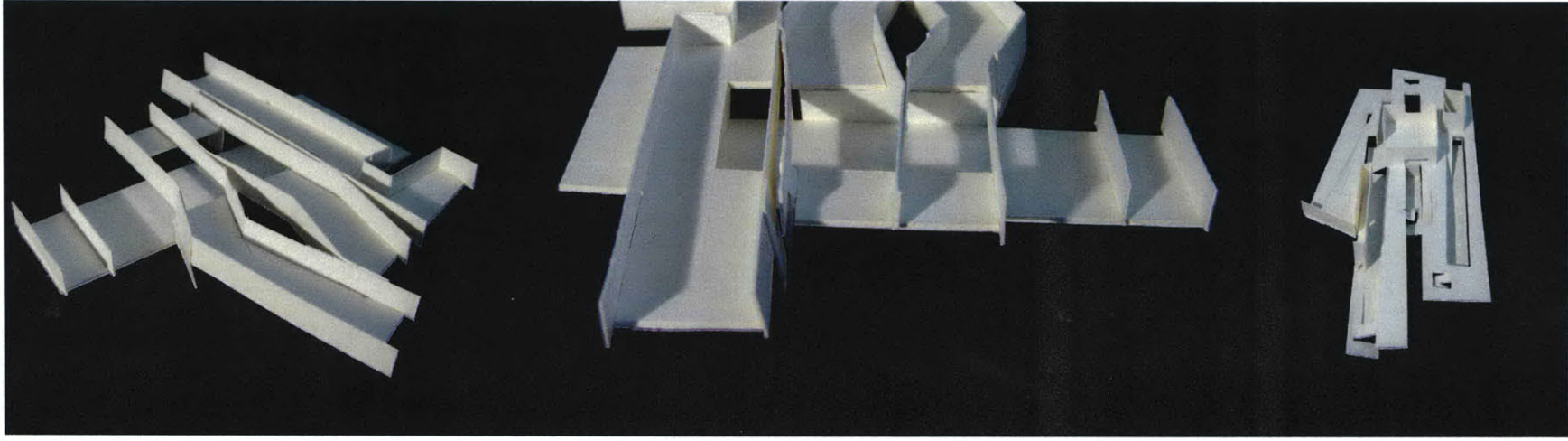



## secondary strategies





### **Waiting Infrastructures**

Medical waiting rooms provide for only one experience, that of sitting in a lounge chair and maybe reading a magazine. This arrangement is suitable to small, thinly defined waiting rooms. A waiting infrastructure (as opposed to a waiting room) requires a different attitude toward the specificities and diversities of activities occurring in the waiting zone. Seating systems need to accommodate and provide for this flexibility and diversity.

### **Institutional Gradients**

The clinic, at present, is the space of the doctor. And it feels this way. When one crosses the threshold, one forfeits privacy and control to the institution. I propose a strategy of threshold thickening, to create a middle ground between doctor and patient and between inside and outside.

### **Systems Integrations**

In many interstitial hospitals, the space of the mechanical systems is equal in dimension that of the inhabitable space—a sectional sandwich. Though this may maximize institutional efficiency, it kills any spatial differentiation in section due to the huge floorplate

dimension. An alternative approach to mechanical services, especially in low-rise buildings in warm climates, may be an integration of systems into a thick surface that can wrap around programmatic spaces and conform to the site in a targeted and specific manner.

### **Urban Extensions**

The site is urbanistically strategic because it lies at the edge of the downtown commercial district and bridges between the town and the landscape. I propose that the hillside trail system be extended downtown and the building serve as a conduit to bring people up onto the hill and back down again. Furthermore, it is strategically advantageous for some of the downtown commercial activity to bleed into the health clinic and provide transitory programs for patients while waiting (massages, parlors, and cafes).

### **Urban Tethers**

The space of the clinic must be tethered to the experience of the site and of the larger town. Waiting spaces must be strategically placed to take advantage of the unique qualities of light, wind, and view on the site.

# tactics

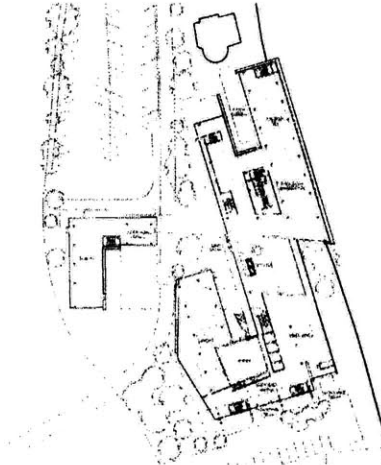

ground level plan

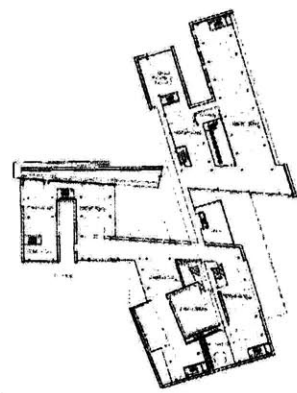

upper level plan



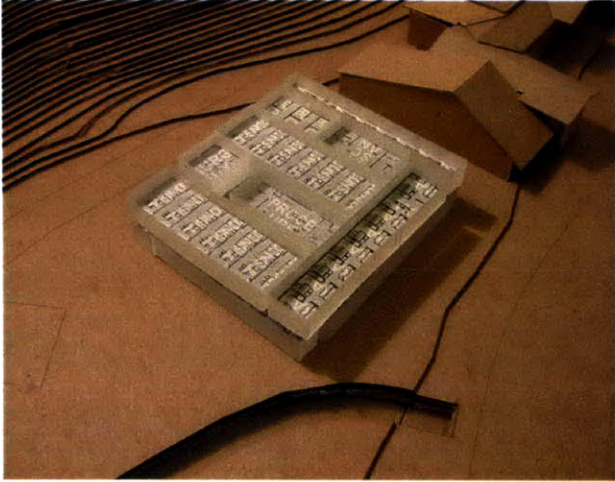

programming study

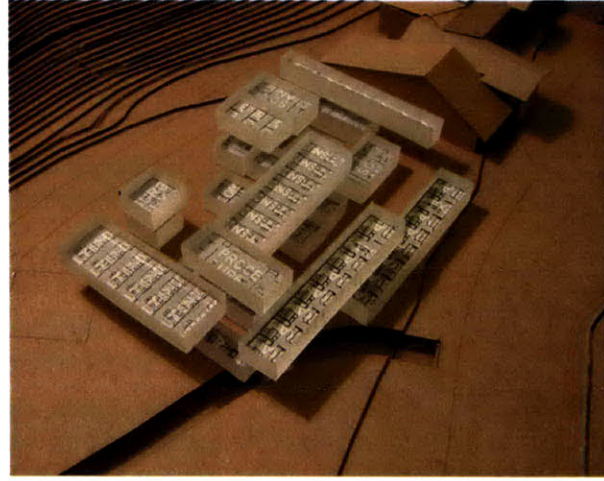

programming study pulled apart

### Pulling Apart

My initial inclination while tactically engaging the issue of the dense mat structure of the clinic was to pull apart that structure. By pulling tissue apart one creates interstitial space that can be occupied with different velocities and in different modes.

In this case, both the site and the program provides impetus for pulling. The building mass was pulled apart to allow the river to bisect the complex. This cross-grain pulling created the space for the river as well as the secondary outdoor courtyard spaces linked by circulation spines moving parallel to the water, the wind and canyon. Programmatically, this allowed the doctors to move with the grain of the site and the patients to move across the grain—between care, support, and waiting spaces



first study model



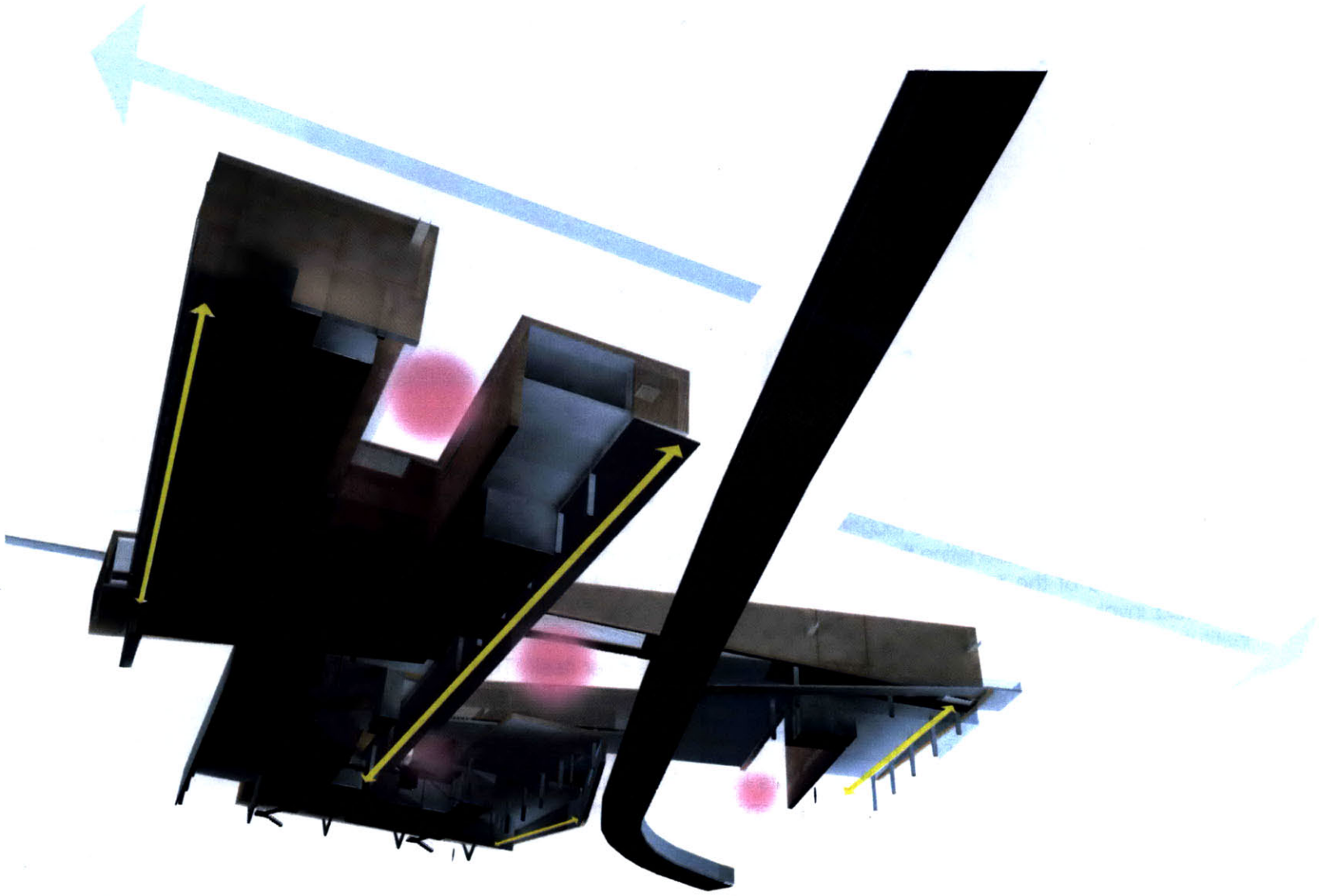

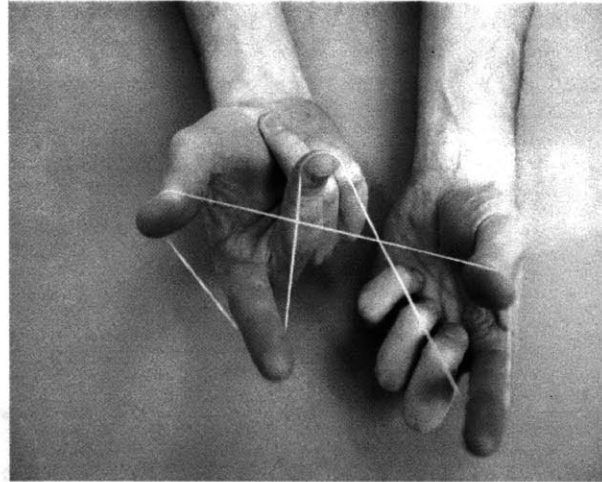
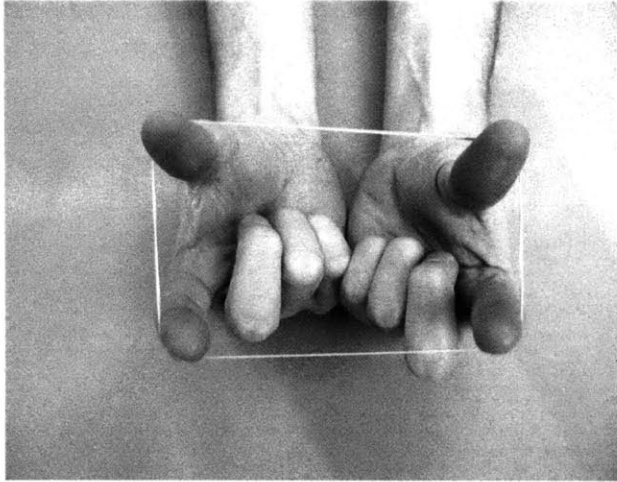

### Crossing Over

One of the Foucault elements of disciplinary space was the strictly defined enclosure. Like a prison wall, the taught skin of the hospital and clinic usually provides a clear and often alienating threshold between the space of the institution and the outer world of the public (or the inner world of the individual). Crossing the threshold involves handing over some agency of control over one's body to the institution.

Turning a skin inside-out involve making that skin cross over itself. This automatically complicated the relationships between inside and out, establishing different thickness of thresholds and more ambiguous subregions and middle grounds.

In this case, the space of the hillside pushes across the grain of the complex creating a singular cross-over event that results in an entry court and defines the primary waiting spaces, public amenity zones, and points of vertical circulation.

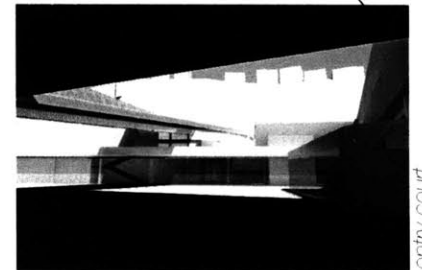
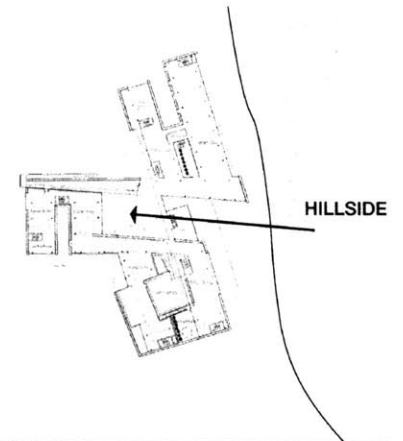

entry court

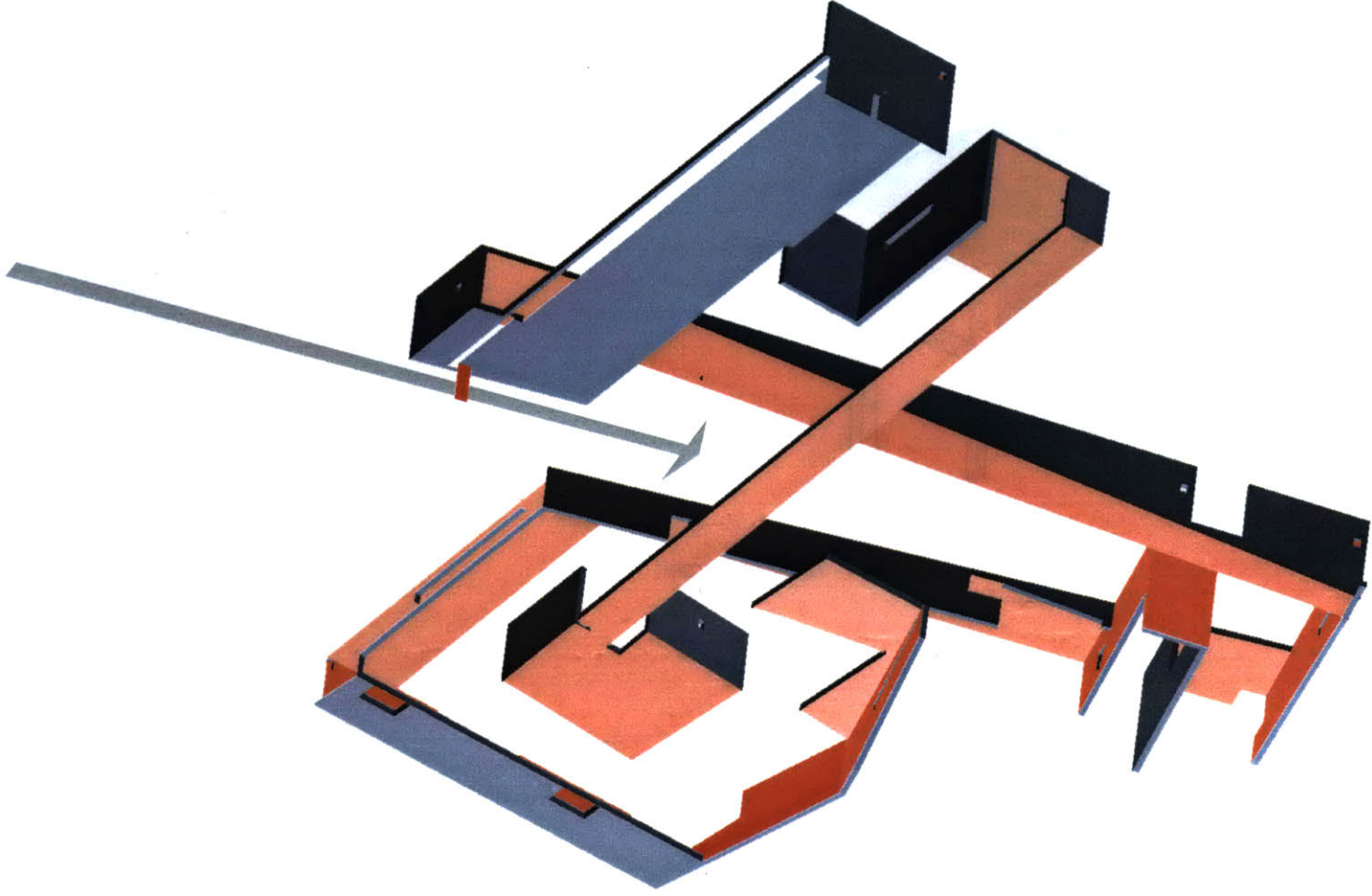

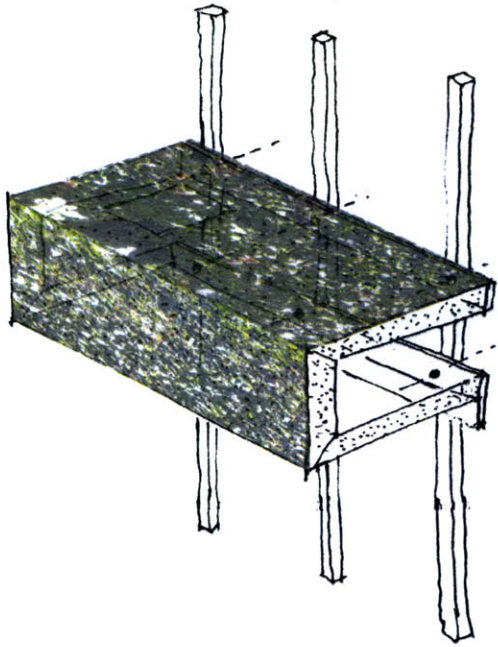

*brick as garden*

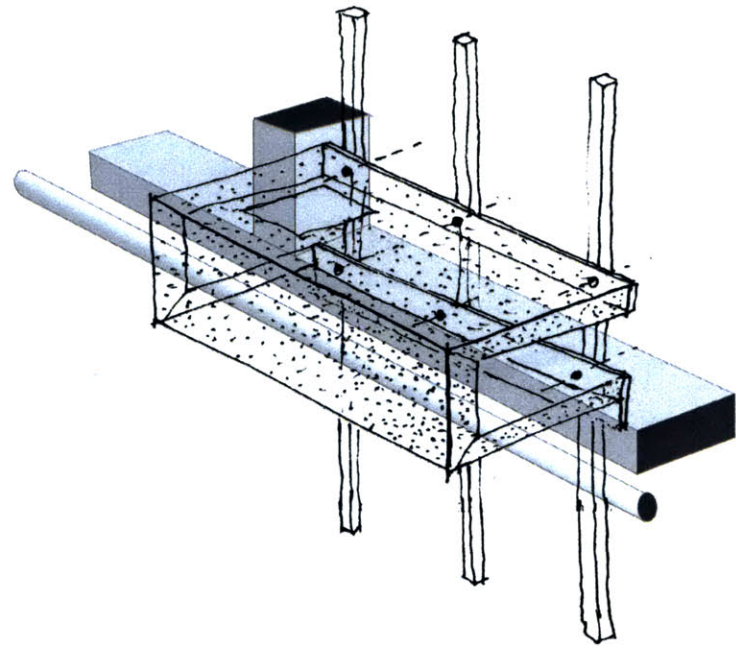

*brick as infrastructure*



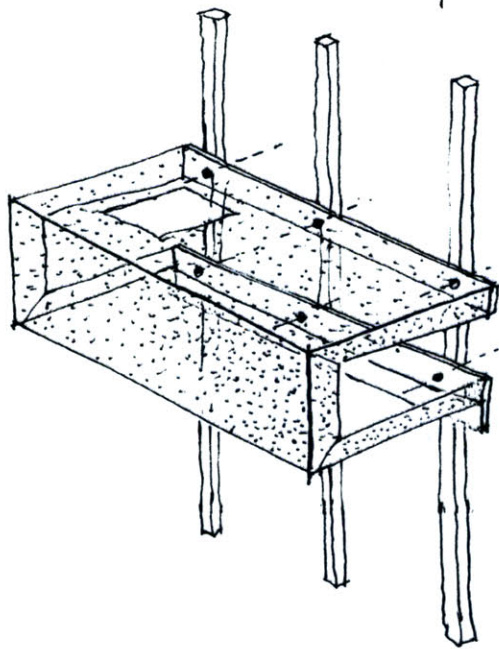

*brick as rainscreen*

### **Systems Integration**

I propose a light, thick skin composed of perforated metal bricks mounted on a changeable backing wall. The backing wall can be sometimes transparent, sometimes planter, sometimes solid, etc. Such a thick skin allows for the tactical reinterpretation of the poche space as a space for mechanical services. Especially in a warm climate, the skin can be a conduit for wrapping air, electricity, water and light around the building. A 2-3 foot thick exterior wall composed of these hollow bricks could absorb needs for shade, light, color, and mechanical services and addressed them all in a combined, dynamic response.



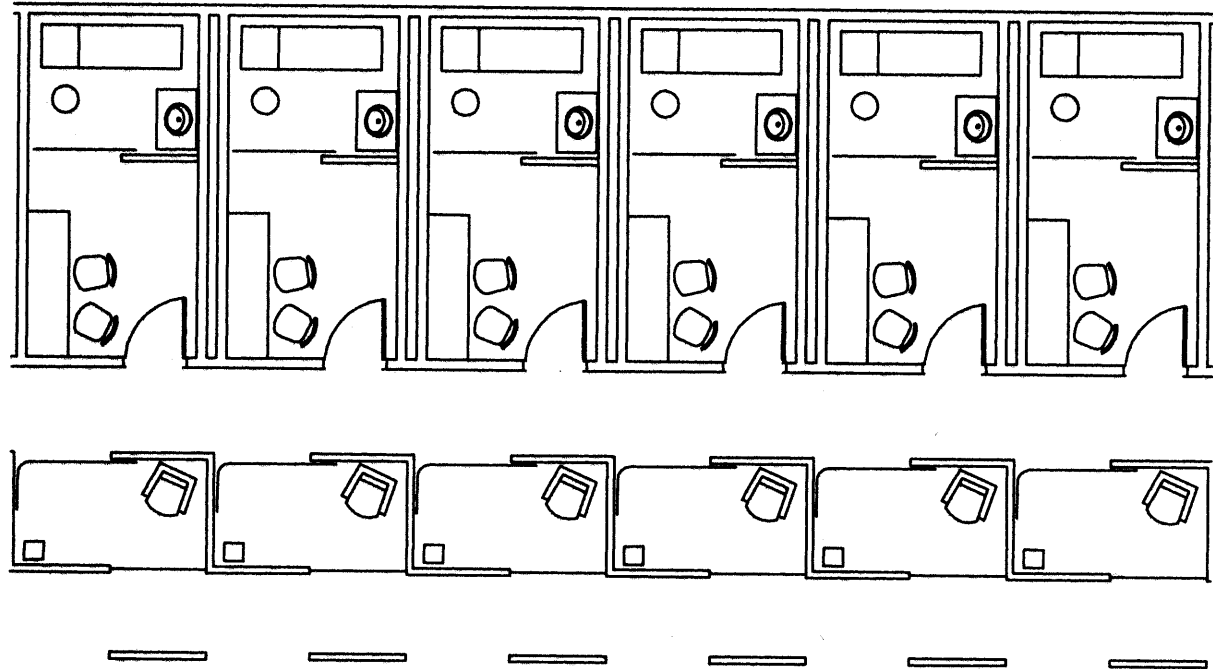

*Sub-waiting spaces double as changing rooms and places for patients to leave their belongings or family members during an exam.*

### Privacy Gradient

As a tactical approach to the thickening of the traditionally stark threshold between the individual and the institution, I propose a series of sub-waiting spaces and semi-private consultation spaces. These would create a gradient of privacy cessation that would ease the individual into the space of the doctor and provide a neutral middle ground between the two.

At the scale of the building this same thickening can occur between exterior and interior environments by softening the perimeter envelop and bringing patients slowly into the fold of the clinical environment (see "Crossing Over" tactic).

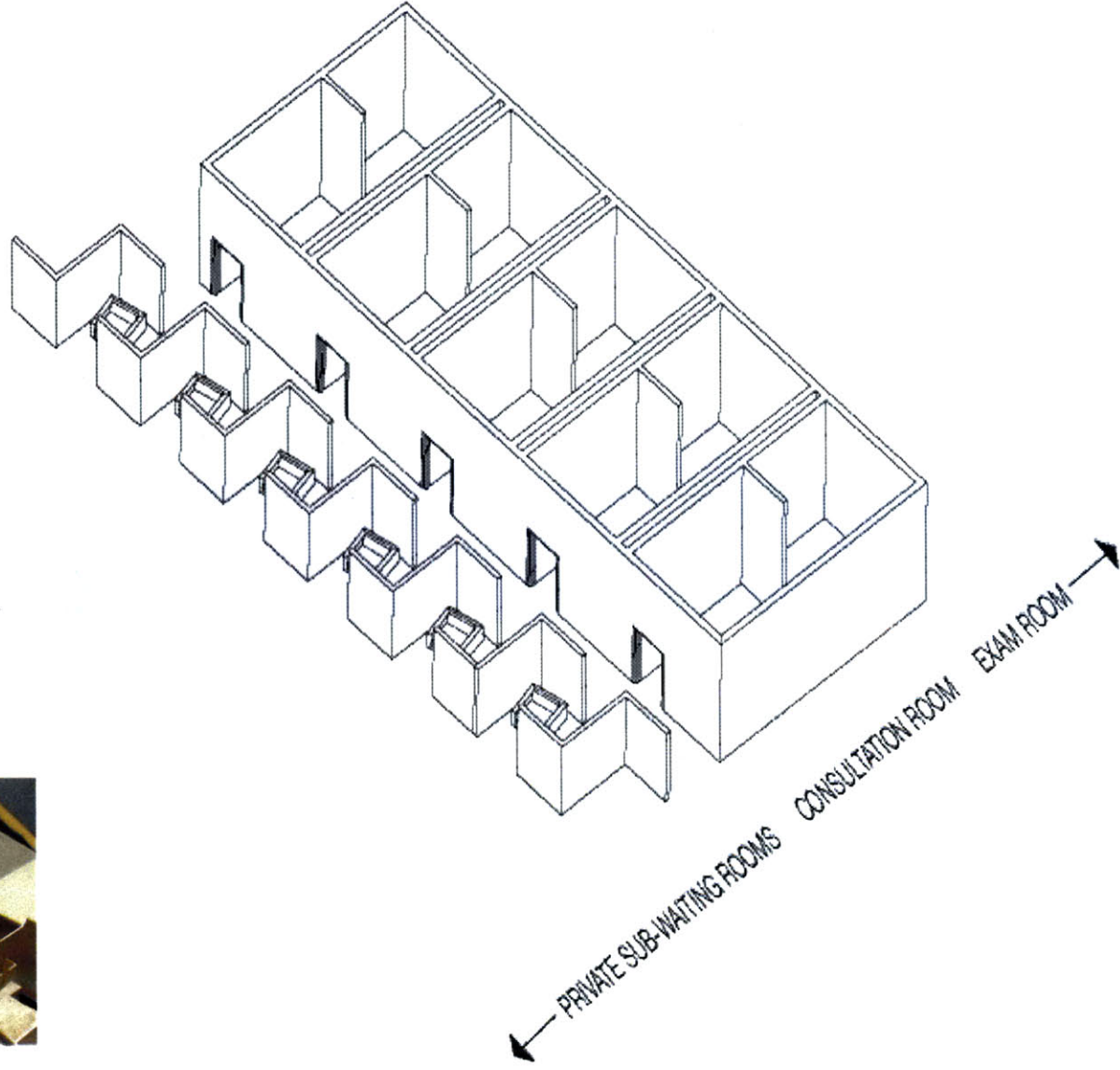
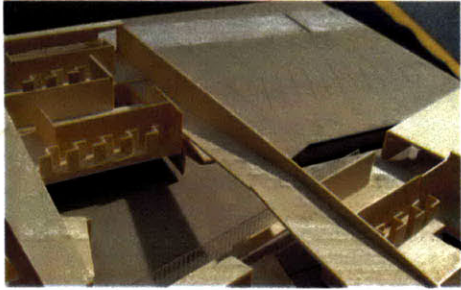

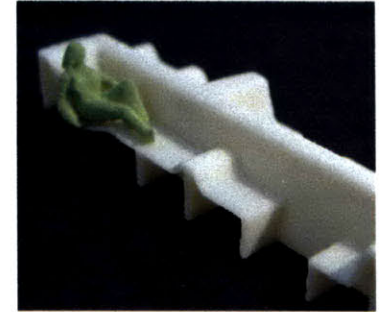

## Waiting Infrastructure

This seating system tactically addresses the issue of an effective waiting infrastructure. Upholstered modulators plug into a spine structure that can be any length. The systems accommodate many modes of inhabitation, degrees and socializing, and levels of comfort for various lengths of sitting and degrees of sickness and discomfort.



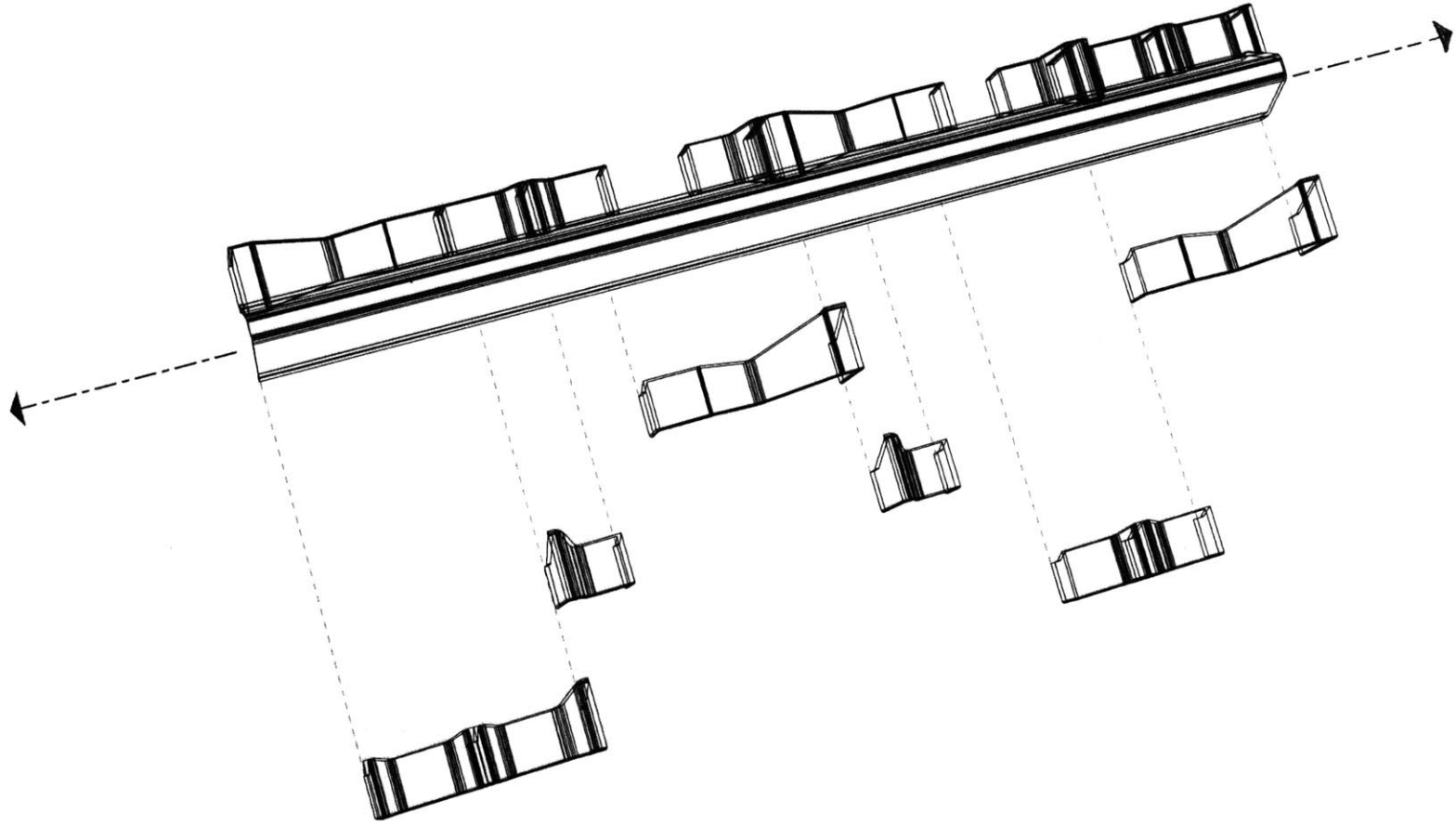

# paths



doyenne



hiker



vacationers



working mother

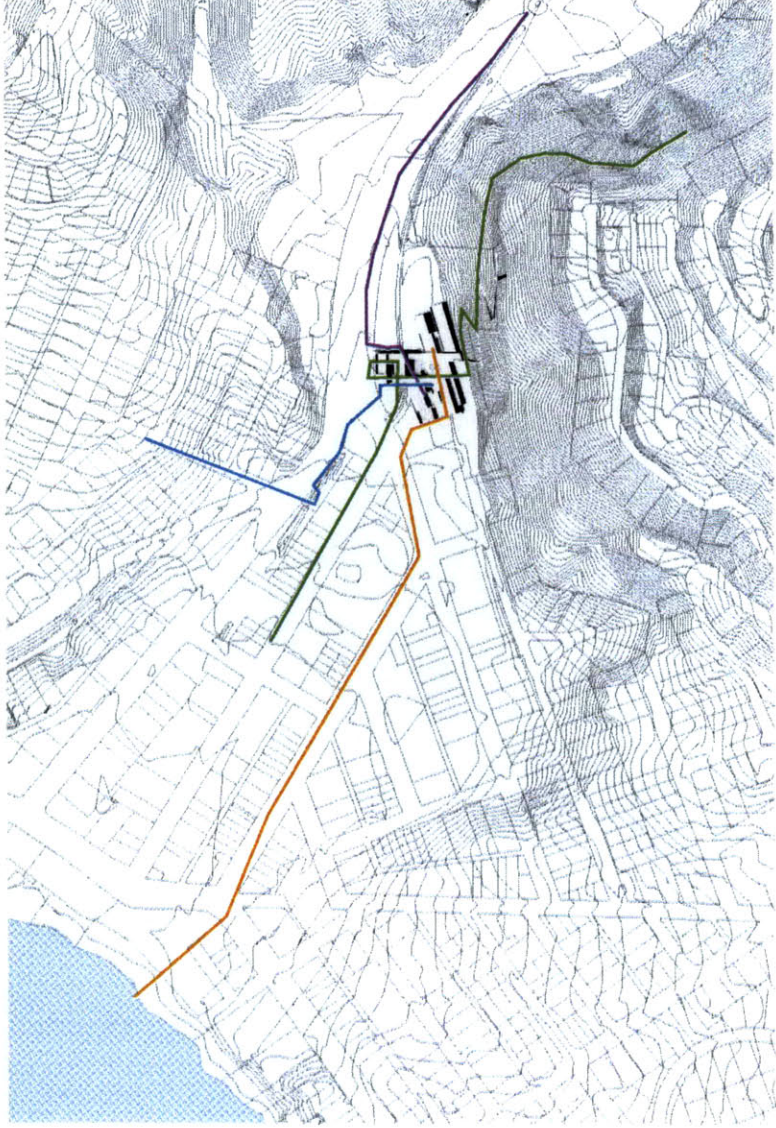

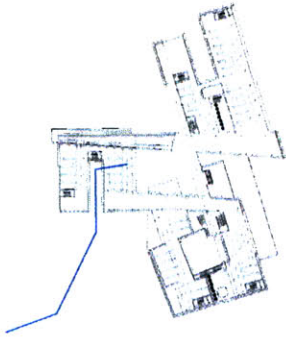

doyenne | enters from the 3rd avenue bus stop



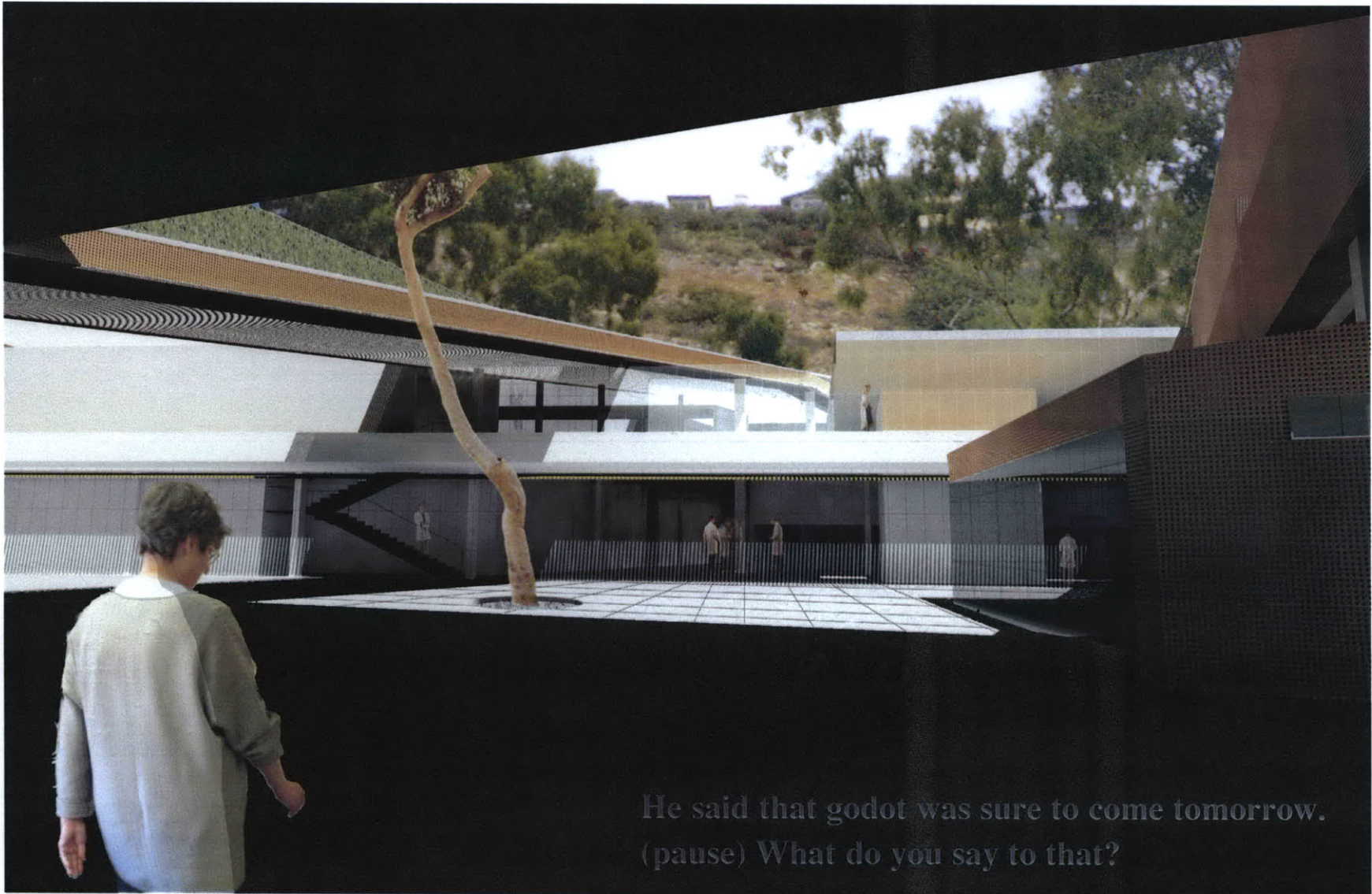

He said that godot was sure to come tomorrow.  
(pause) What do you say to that?

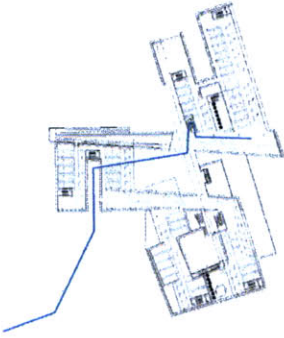

doyenne | after registering she waits 15 minutes at radiology

Then all we have to do is to wait on here





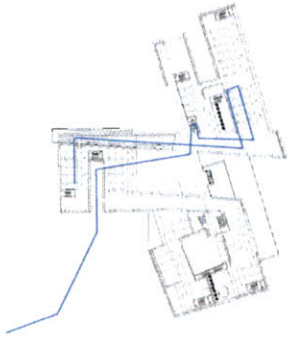

doyenne | while her x-rays are developed she has a manicure



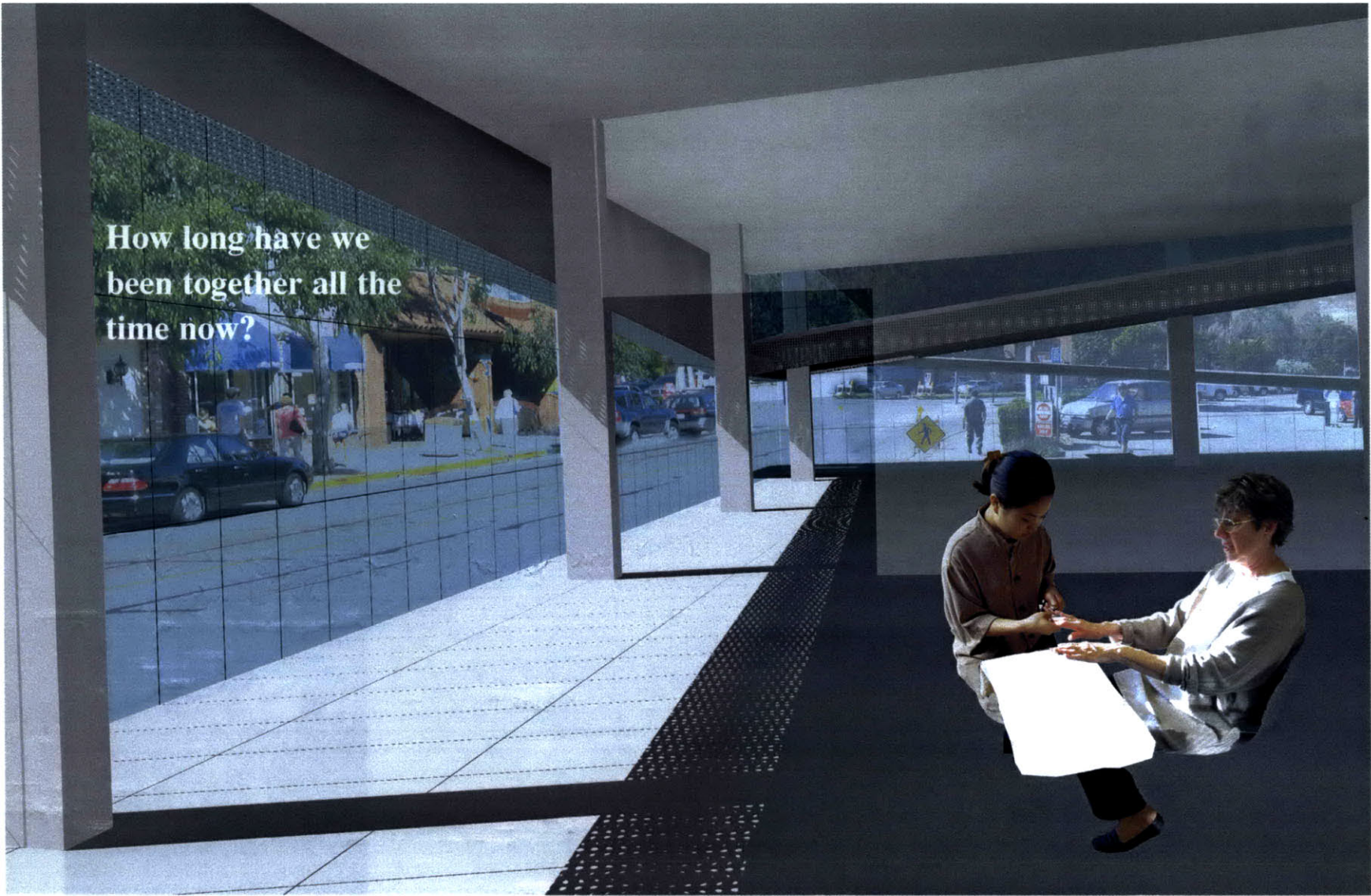



**vacationers** | he cuts his foot at the beach, they walk down forest avenue to the clinic

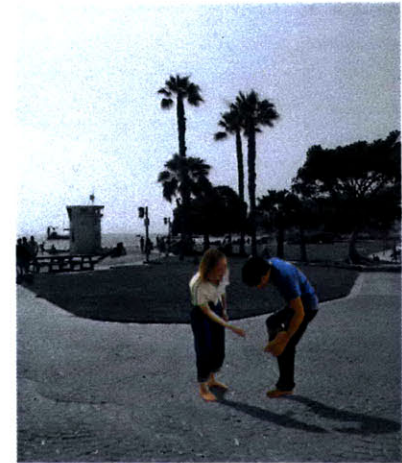





I don't know, fifty years maybe.

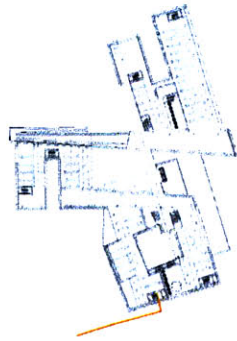

**vacationers** | he watches TV in the emergency room



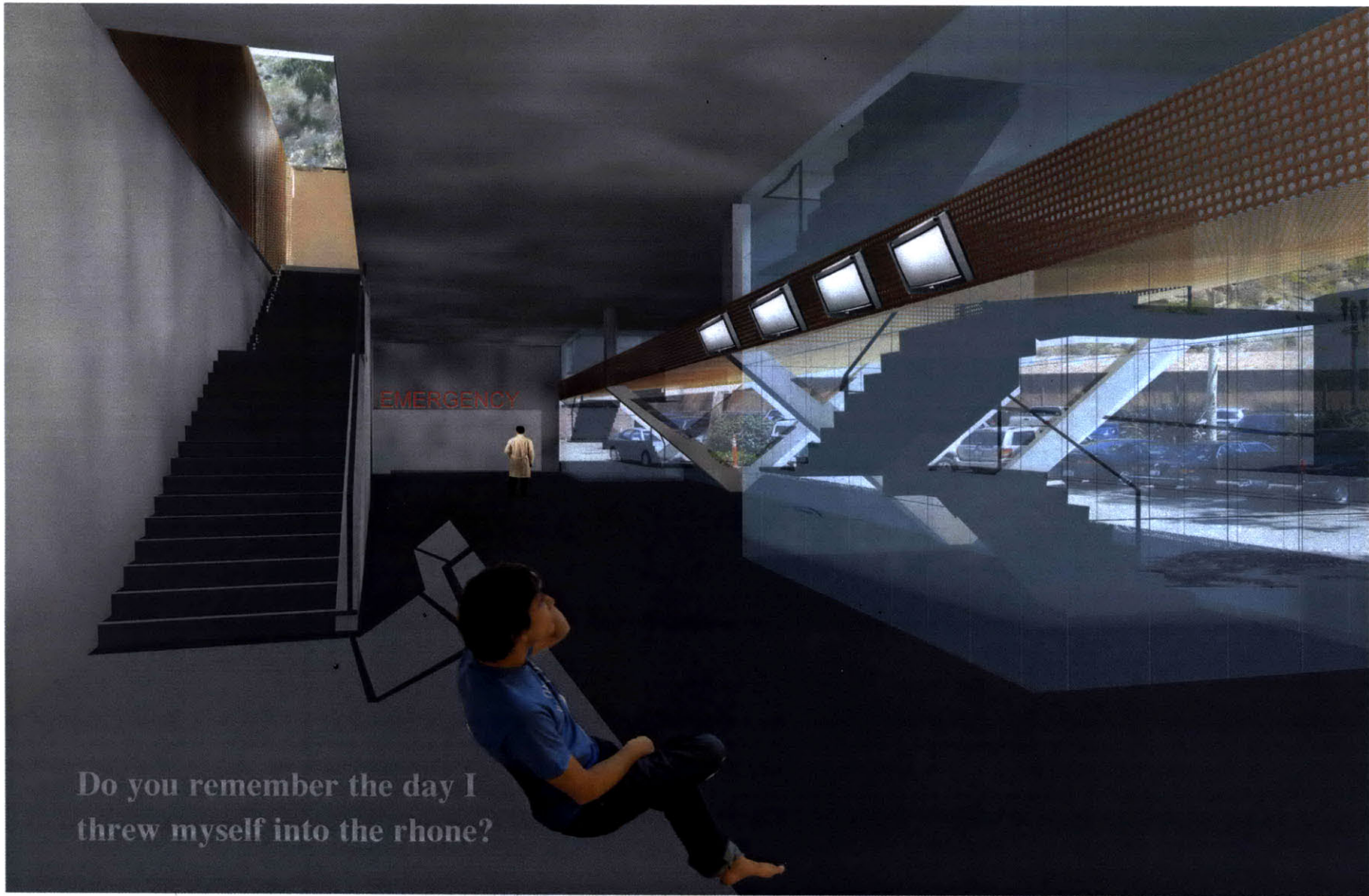

Do you remember the day I  
threw myself into the rhone?

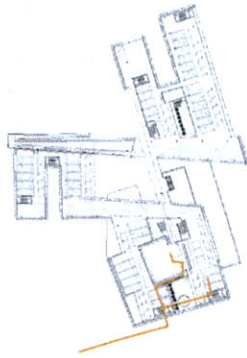

**vacationers** | she gets coffee from the cafe



There's no good barking  
back on that. Come on.

COFFEE



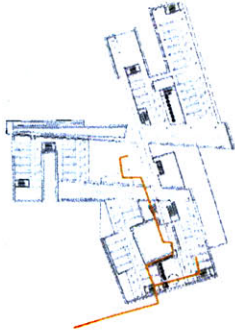

**vacationers** | she waits in the hard garden while he gets stitches





**Wait!**  
**I'm cold!**

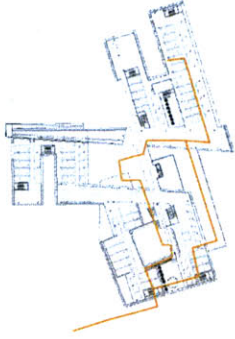

**vacationers** | he gets blood drawn while looking at the water

I sometimes wonder if we wouldn't have been better off alone.



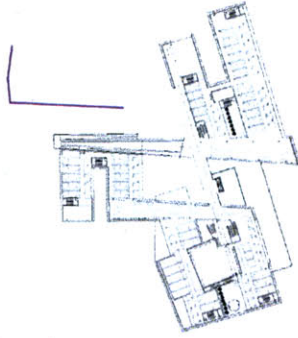

working mother | arrives by car



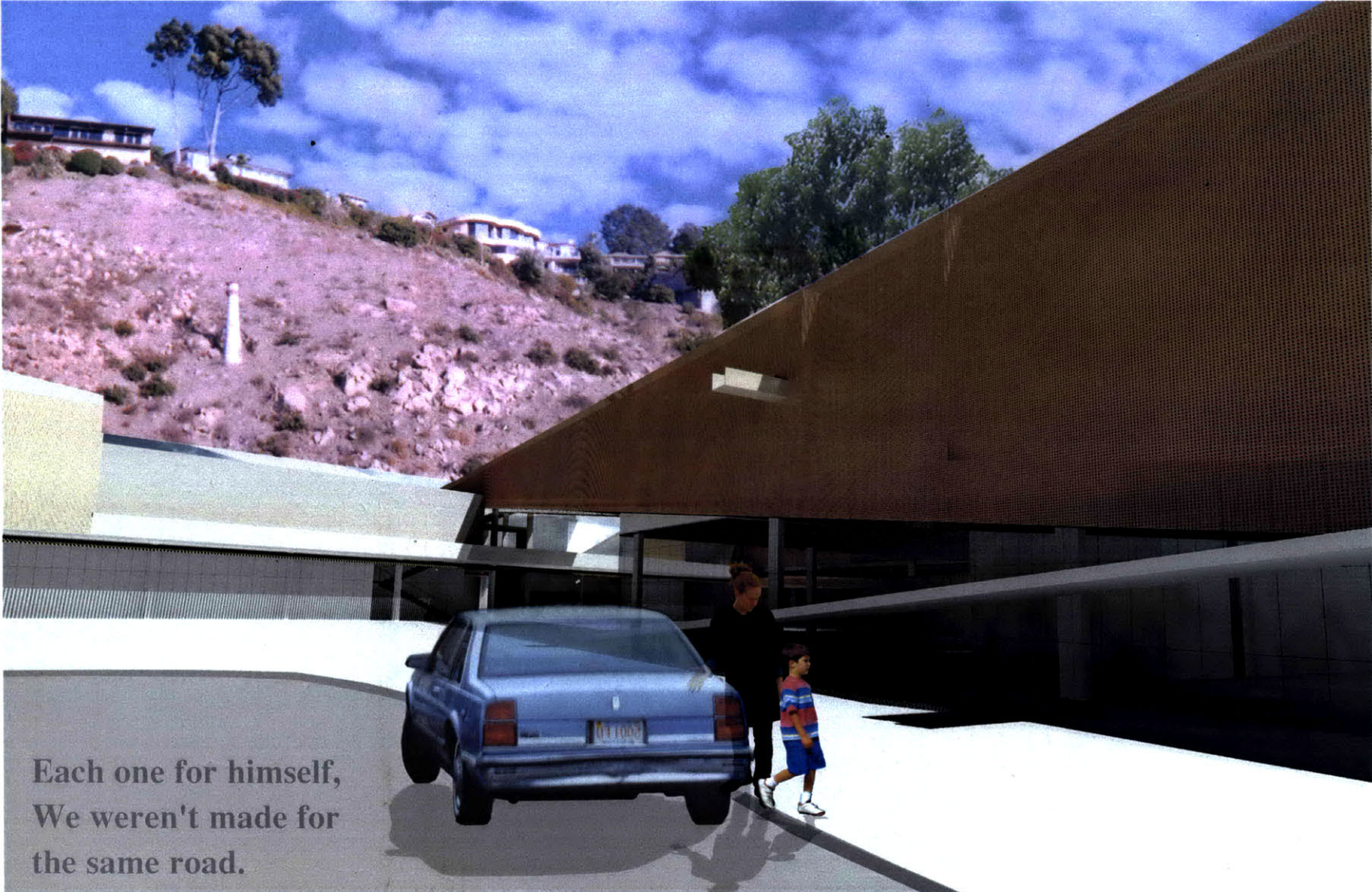

Each one for himself,  
We weren't made for  
the same road.

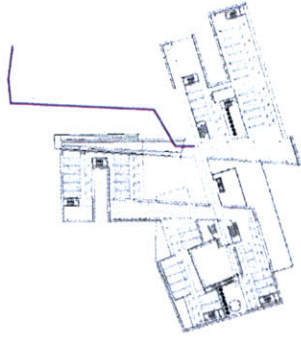

**working mother** | registers, waiting time will be 30 minutes



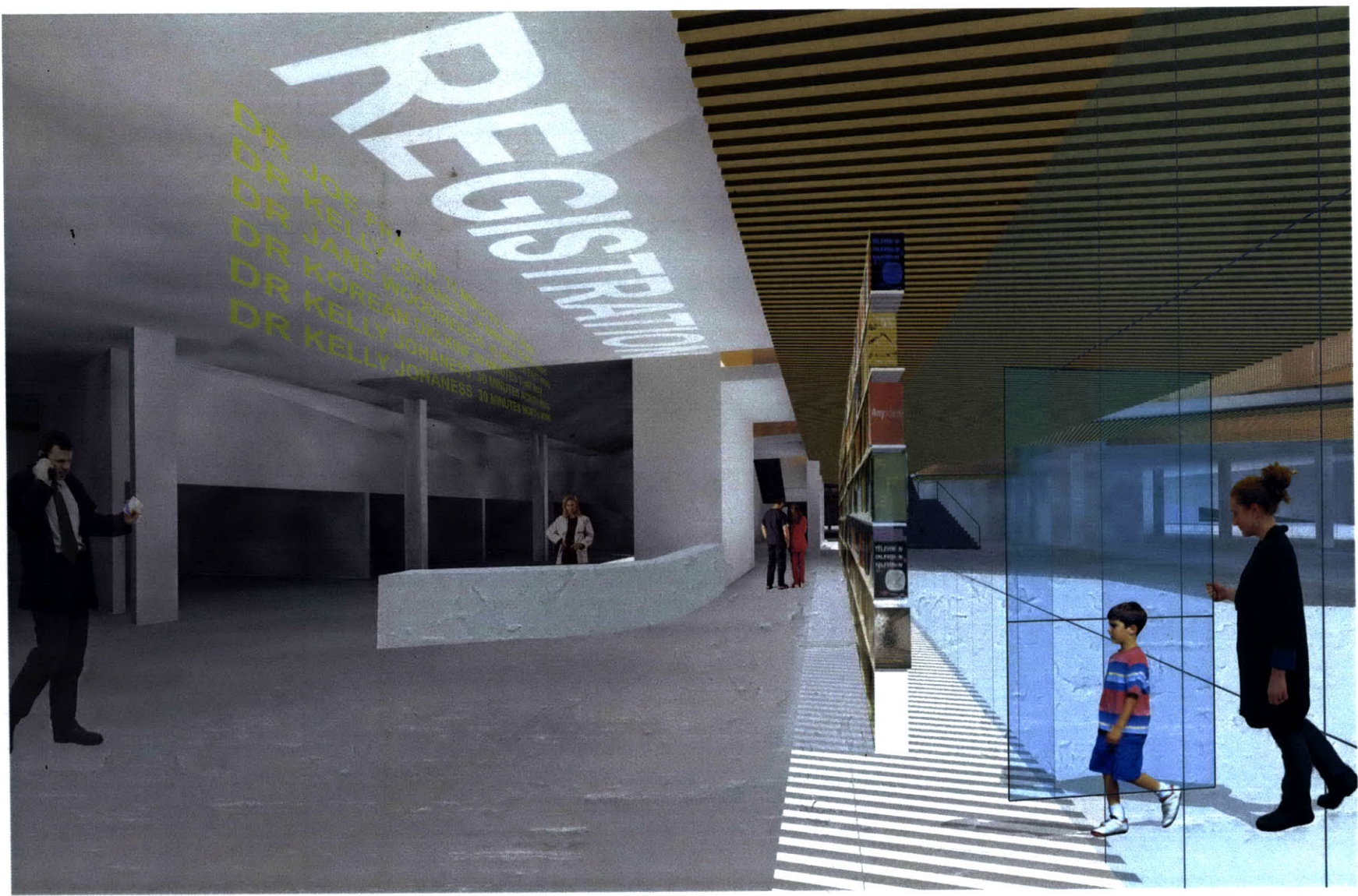

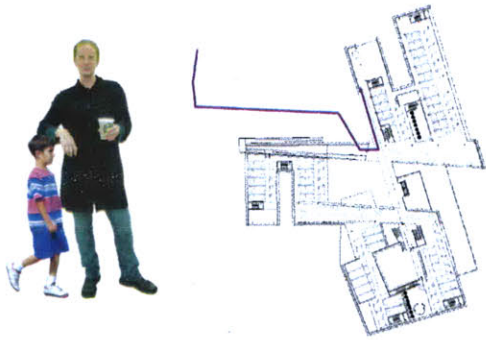

working mother | drops her kid off at the day care





(without anger). It's not certain  
no, nothing is certain.

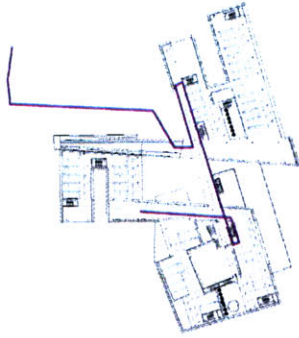

working mother | waits at her doctor's office



we can still part, if you think it would be better .

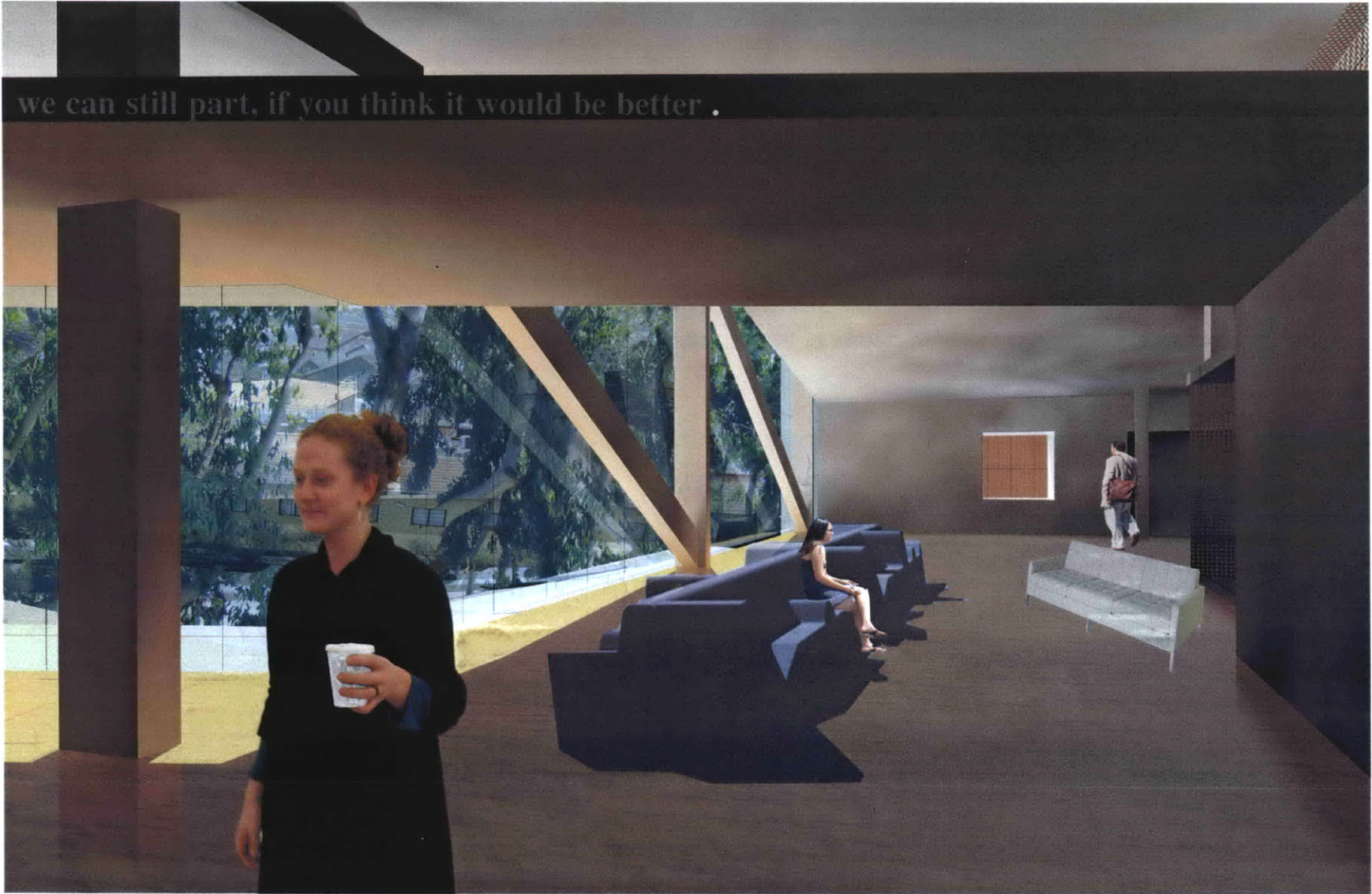



**hiker** | he buy trails mix, rounds the ramp, heads for the hill....and looks back.











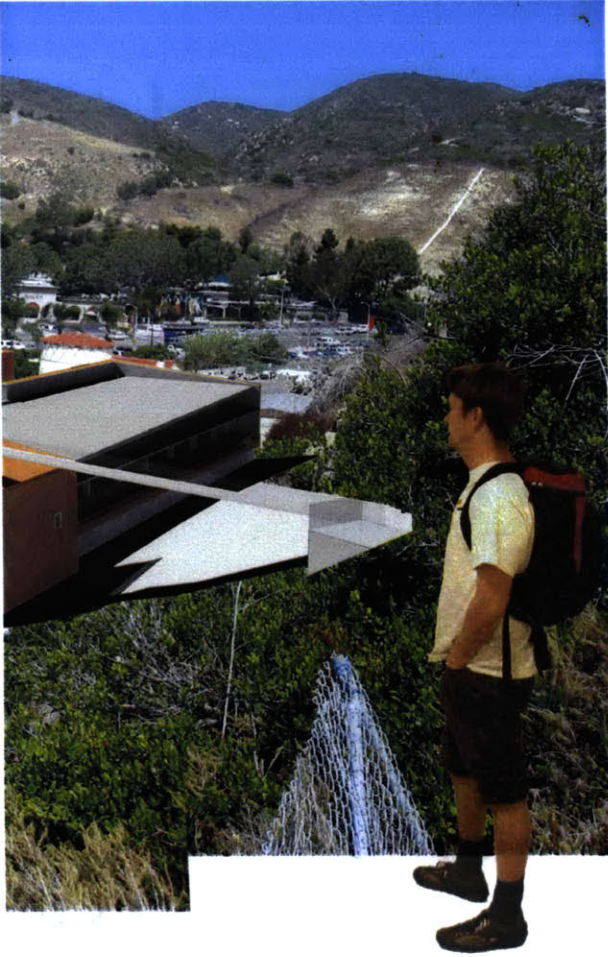

**well, shall we go?**

**yes, let's go.  
(they do not move.)**

# drawings

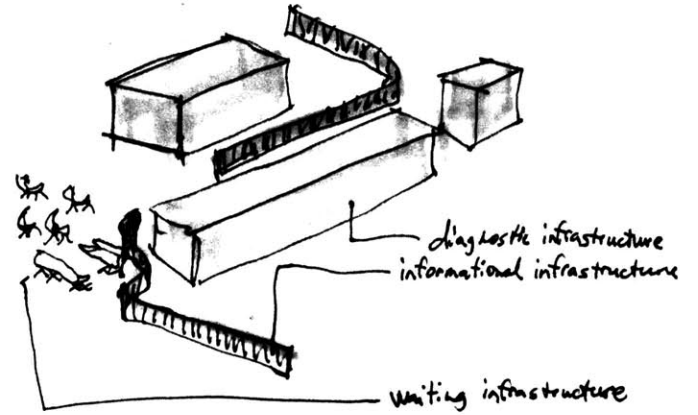





site location plan

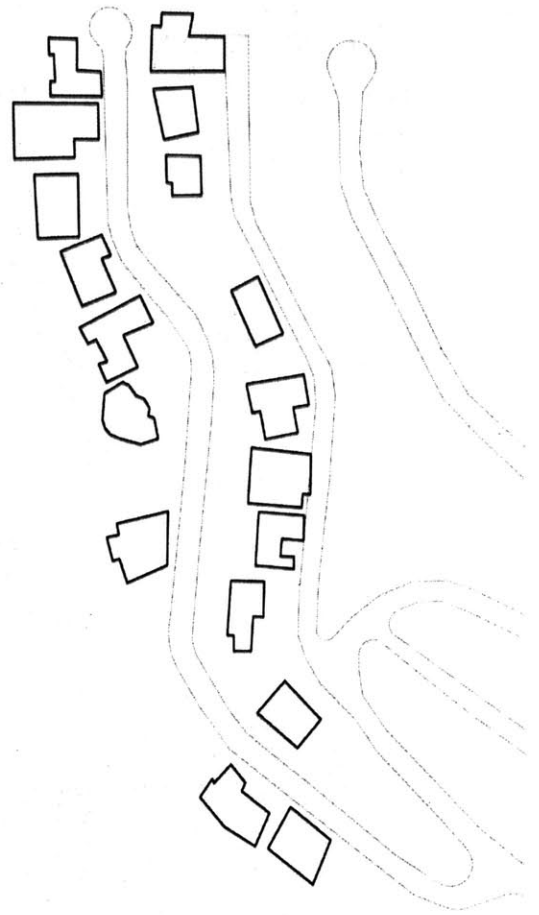

site plan

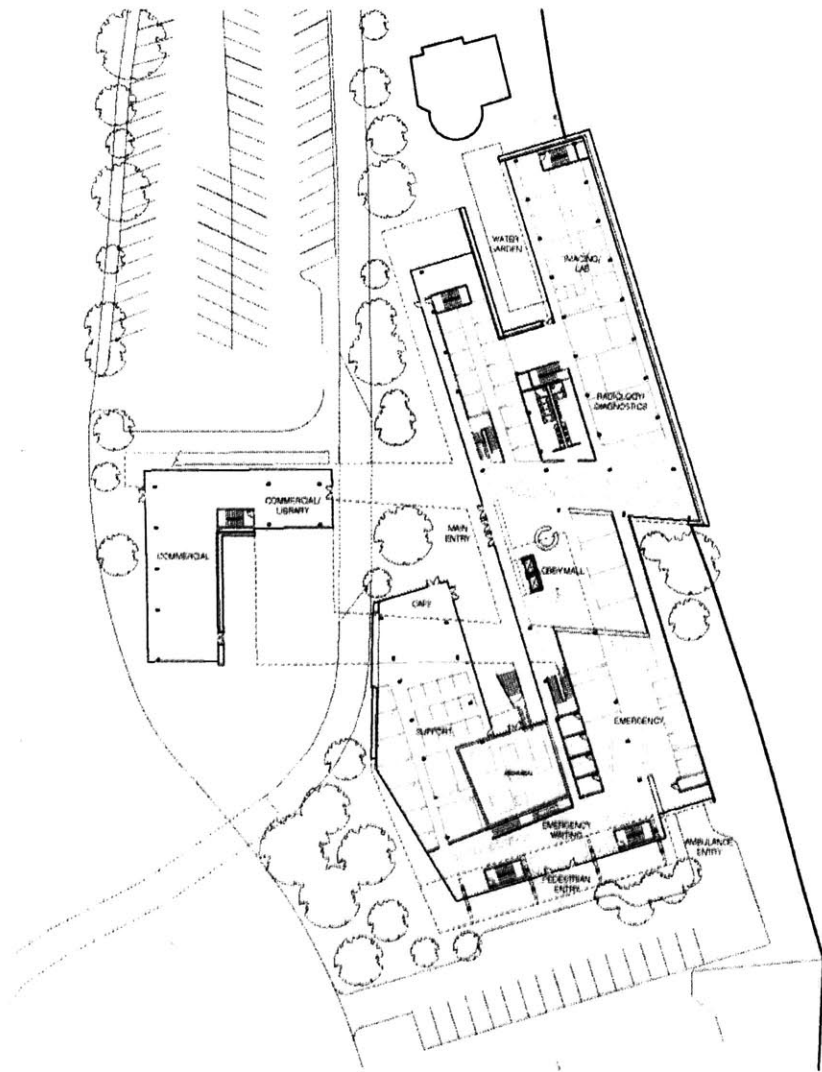

ground level plan

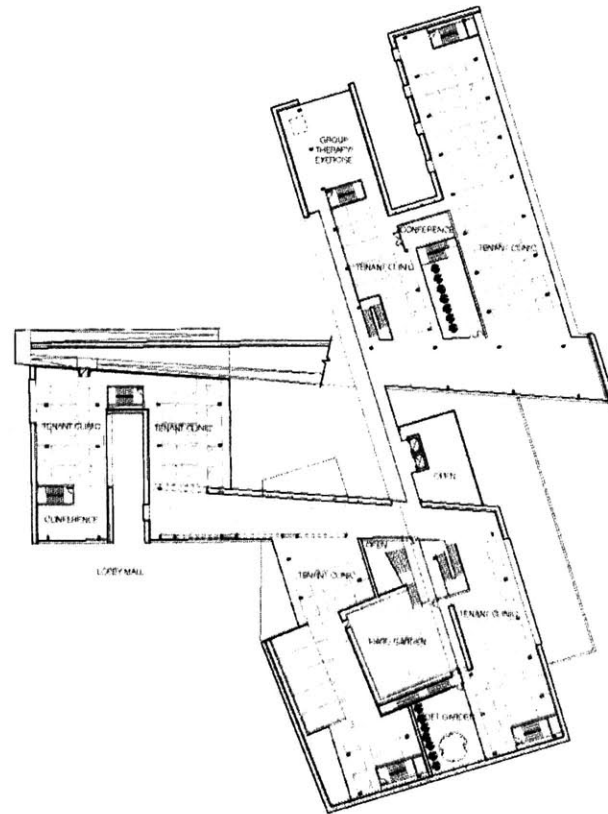

upper level plan



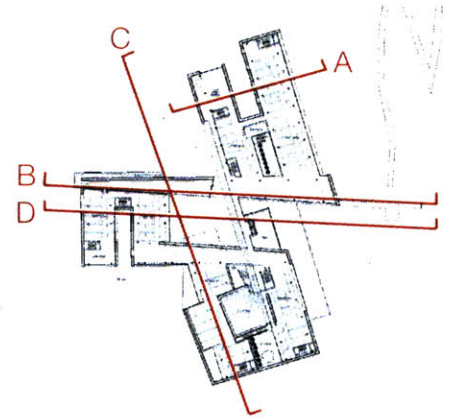
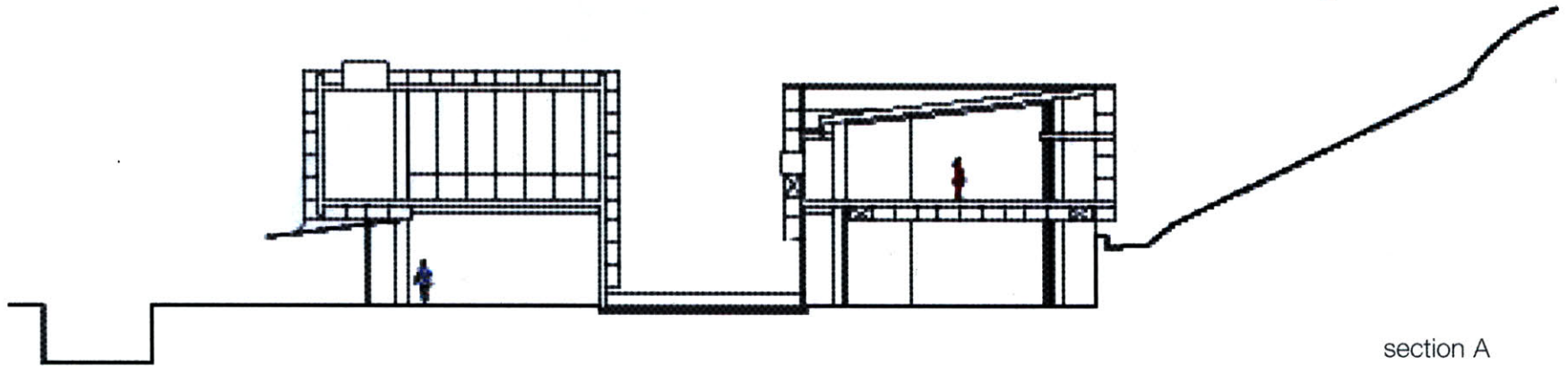

section A





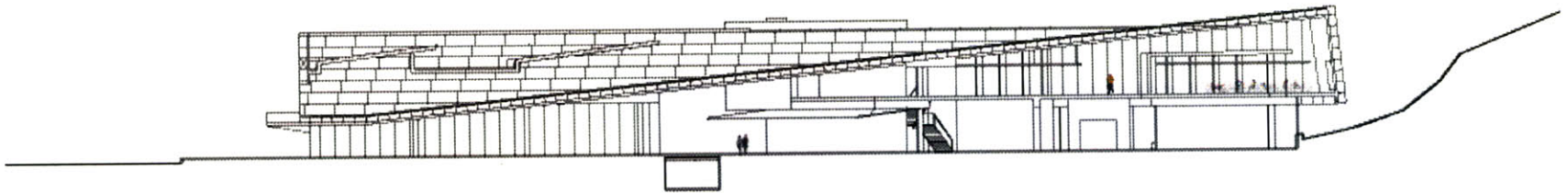

section B

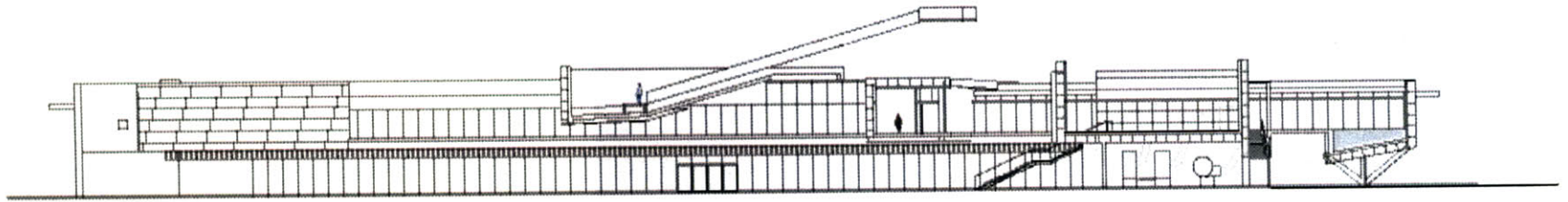

section C

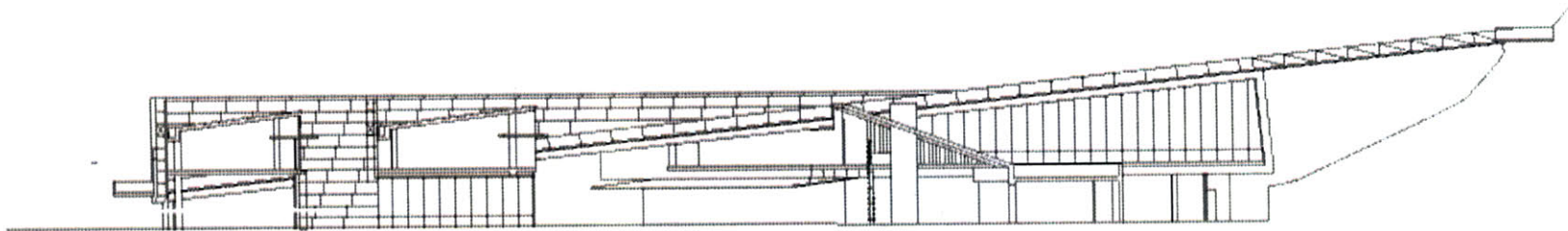

section D



**models**



1/32" model



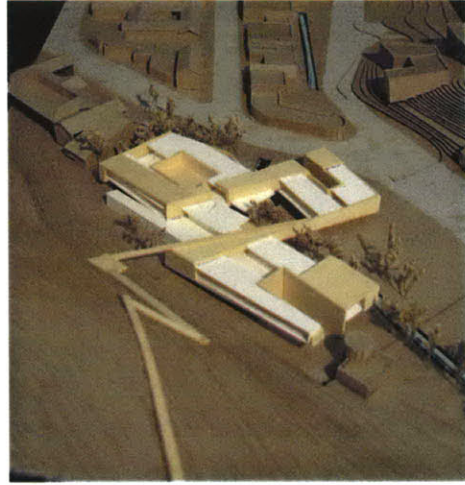
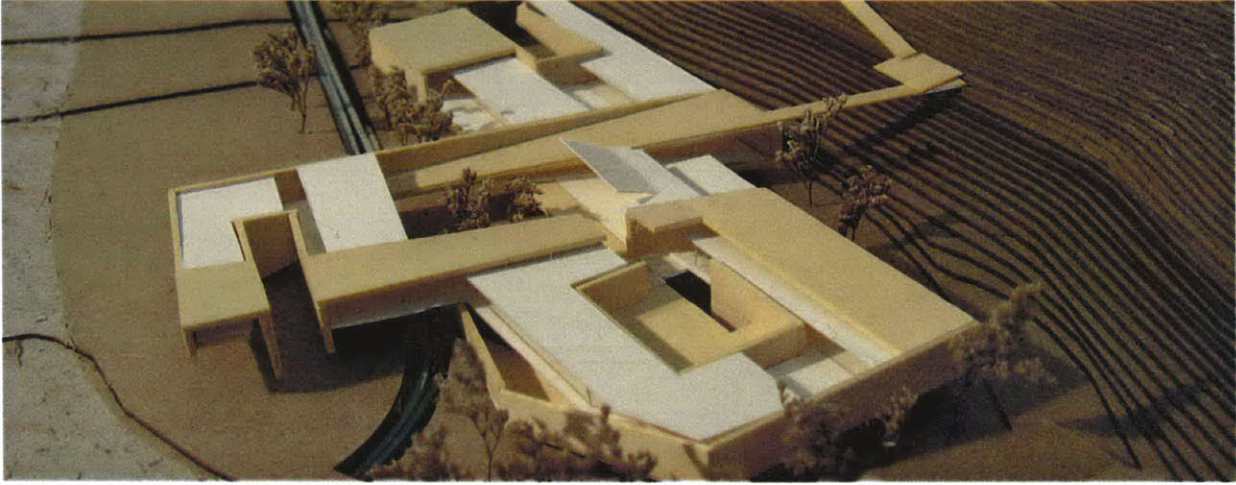



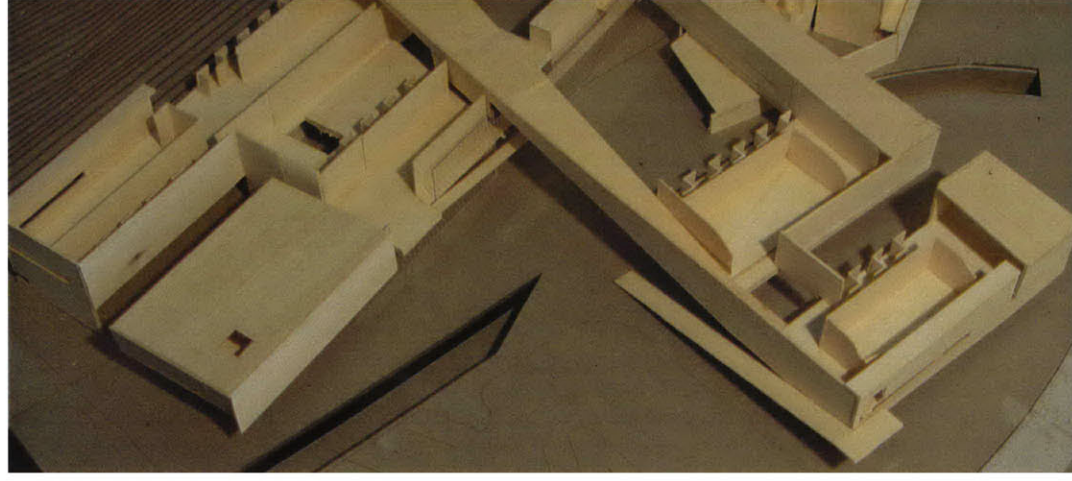
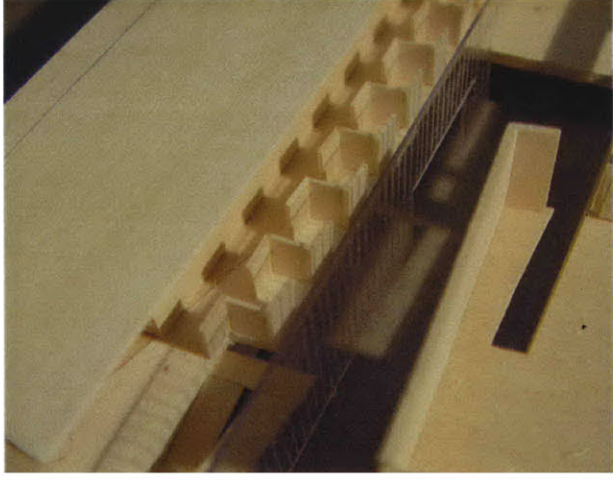



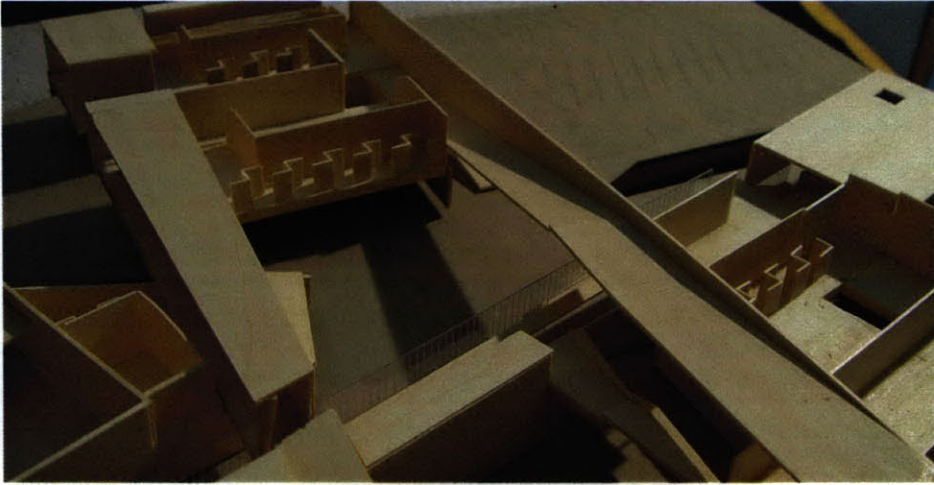

1/16" model

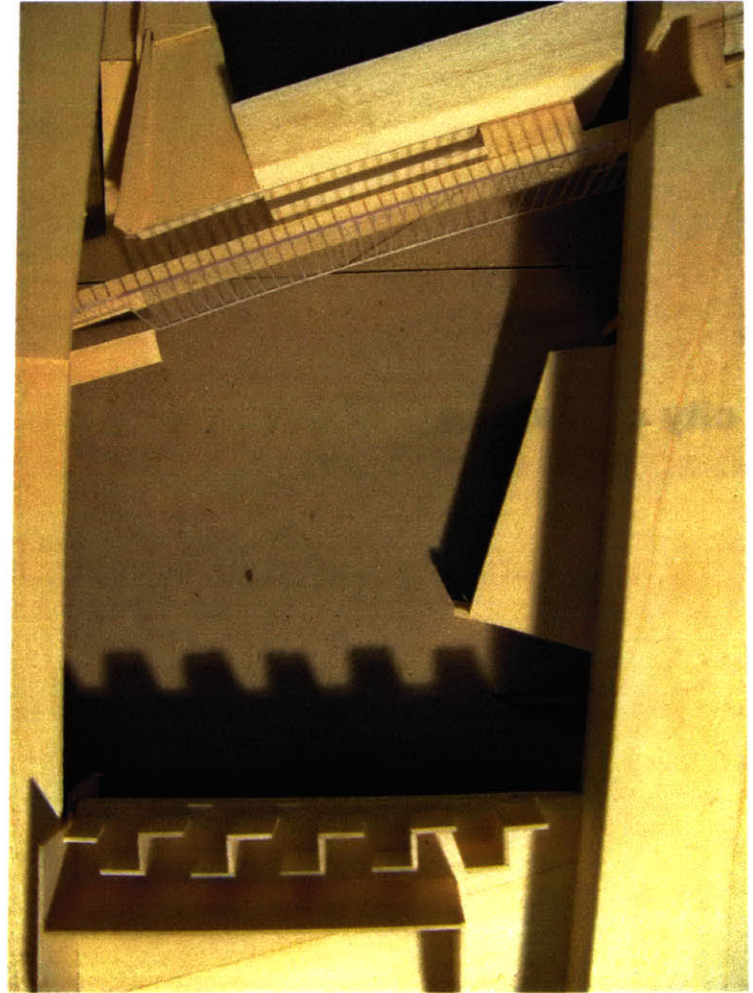

**city of waiting**

## References & Illustration Credits

<sup>1</sup>Corner and MacLean, p.67.

<sup>2</sup>Verderber, p.52.

<sup>3</sup>IBID

<sup>4</sup>Lewis et al.

<sup>5</sup>*Material Process*, p.65

<sup>6</sup>Valins

<sup>7</sup>Koolhaas, p.1133.

<sup>8</sup>Stafford

<sup>9</sup>Hernandez

<sup>10</sup>Verderber

<sup>11</sup>IBID

<sup>12</sup>Foucault

<sup>13</sup>IBID

<sup>14</sup>Verderber

<sup>15</sup>IBID

**city of waiting**



## Bibliography

Adorno, Theodore W. "Functionalism Today." trans. Jane Newman and John Smith. *Oppositions* 17. Summer 1979. pp.30-41

Bachelard, Gaston. *Poetics of Space*. (trans. Maria Jolas. Boston: Beacon Press, 1969, pp. 3-20.

"*Barcos & Enríquez: cenro de salud, Buñuel, Navarra*" *AV monografias*. Jan.-Apr. 2002. pp.110-114.

Bloomer, Jennifer. "Abodes of Theory and Flesh: Tabbles of Bower." *Assemblage* 17, April 1992.

Canguilhem, Georges. *The Normal and the Pathological*. New York: Zone Books, 1991.

Corner, James; MacLean Alex S. *Taking Measures Across the American Landscape*. New Haven: Yale University Press, 1996.

Crary, Jonathan and Kwinter Sanford. (1992). *Incorporations*. New York: Zone Books.

Czarnecki, John E. "Health care: specialized wellness." *Architectural Record*. July 2002. pp.131.

De Sola-Morales, Ignasi. "Weak Architecture." trans in *Differences: Topographies of Contemporary Architecture*. ed Sarah Whiting. trans Graham Thompson. Cambridge: MIT Press. 1996.

Deleuze, Gilles. "Postscripts on the Societies of Control." *October*. v 59, 1992. pp.3-8.

Dyck, Isabel. "Everyday Geographies: Home, Space, and the Contested Body" *Putting Health into Place: Landscape, Identity, and*

*Well Being*. (1998). New York: Syracuse University Press.

Eisenman, Peter. "Post-Functionalism." *Opposition 6*. Fall 1976.

Eyles, John; Litza, Andrea. "Place, Participation, and Policy: People in and for Health Care Policy." *Putting Health into Place: Landscape, Identity, and Well Being*. (1998). New York: Syracuse University Press.

Feher, Michel ed. *Fragments for a History of the Human Body*. New York: Zone Books, 1989.

Foucault, Michel. "Space, Knowledge, and Power." Interview with Paul Rabinow.

Foucault, Michel. *The Birth of the Clinic*. 1973 translation. New York: Vintage Books, 1994.

Foucault, Michel. *Discipline and Punish*. trans. Alan Sheridan, 1977. New York, Vintage Books, 1979.

Hawthorne, Christopher. "The IDEO cure." *Metropolis*. Oct. 2002. pp.100-105,141,143-144.

Hernandez, Anthony. *Waiting for Los Angeles*. Tucson: Nazraeli Press, 2002.

Jameson, Frederic. *Postmodernism, or the Cultural Logic of Late Capitalism*. London: Verso, 1991. pp.1-6, 38-45.

Jullian De La Fuente, Guillermo. "The Venice Hospital Project of Le Corbusier." *Architecture at Rice* 23 (1968).

Kobus, Richard L. et al. *Healthcare Facilities*. ed. Stephen A. Klimont. New York: John Wiley & Sons, Inc. 2000.

Koolhaas, Rem; Mau, Bruce. *S,M,L,XL*. ed. Jennifer Sigler. The Monacelli Press. 1994.

Kozlowski, Hill. "Towards sustainable health: a planning perspective." *Australian planner: journal of the Royal Australian Planning Institute*. 37.2 2000. p.87-94.

Kwinter, Sanford. "La Citta Nuova: Modernity and Continuity" *Zone* 1-2. New York: Urzone, 1986.

Lewis, Paul; Tsurumaki, Marc; and Lewis, David J. "Situation Normal..." *Pamphlet Architecture 21* New York: Princeton Architectural Press, 1998.

Lawson. "Healing Architecture." *Architectural Review*. 211.1261, 2002. p.72-75.

*Material Process*. Young Architects Series 4. ed. Jennifer N.

Thompson. New York: Princeton Architectural Press, 2003.

Moon, Graham; Brown, Tim. "Place, Space, and Health Service Reform." *Putting Health into Place: Landscape, Identity, and Well Being*. . New York: Syracuse University Press, 1998.

Stafford, Barabar Maria. *Body Criticism: Imaging the Unseen in Enlightenment Art and Medicine*. Cambridge: MIT Press, 1991.

Takahashi, Lois M. "Concepts of Difference in Community Health." *Putting Health into Place: Landscape, Identity, and Well Being*. New York: Syracuse University Press, 1998.

Valins, Martin S. *Primary Health Care Centres*. New York: John Wiley and Sons, 1993.

Verderber, Stephen. *Healthcare architecture in an era of radical transformation*. New Haven: Yale University Press, 2000.

Vidler, Anthony. "Dark Space." from *The Architectural Uncanny: Essays in the Modern Unhomely*. Cambridge: MIT Press, 1992.

Viriliò, Paul. "The Over-Exposed City." *Zone 1-2*. New York: Urzone, 1986.







## **Thanks to-**

Meejin for bleary-eyed, yet coherent crits while on she was on charrette

Ann for her unshakable optimism and enthusiasm

Fernando for giving my project eyes and ears (as well as a great name)

Sheila for keeping me tied to my family

and Katrina for always being there and still managing to like me after all this.





