

# Role of Torque in Haptic Perception of Virtual Objects

by

Steve Wang

B.S., Mechanical Engineering  
University of California, Los Angeles, 1995

SUBMITTED TO THE DEPARTMENT OF MECHANICAL ENGINEERING  
IN PARTIAL FULFILLMENT OF THE REQUIREMENTS FOR THE DEGREE OF

MASTER OF SCIENCE IN MECHANICAL ENGINEERING  
AT THE  
MASSACHUSETTS INSTITUTE OF TECHNOLOGY

FEBRUARY 2001

© 2001 Massachusetts Institute of Technology.  
All rights reserved.

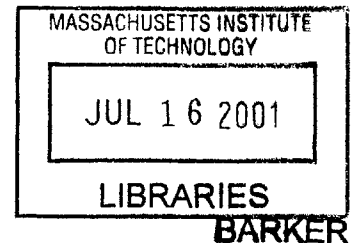

Signature of Author: \_\_\_\_\_

Department of Mechanical Engineering  
January 19, 2001

Certified by: \_\_\_\_\_

Mandayam A. Srinivasan  
Principal Research Scientist, Department of Mechanical Engineering  
Thesis Supervisor

Accepted by: \_\_\_\_\_

Ain A. Sonin  
Chairman, Department Committee on Graduate Students



# **Role of Torque in Haptic Perception of Virtual Objects**

by

Steve Wang

Submitted to the Department of Mechanical Engineering  
on January 19, 2001 in Partial Fulfillment of the  
Requirements for the Degree of  
Master of Science in Mechanical Engineering

## **ABSTRACT**

An experimental study was performed to determine the role of torque feedback in haptic perception of object location within virtual environments. The experimental setup consisted of two Phantom haptic interfaces connected by a common stylus and a ray-based rendering technique for modeling the interactions between the user-controlled stylus and the virtual environment. Subjects were asked to identify 7 locations of a virtual object under various force display conditions, which ranged from force feedback only at the stylus tip to accurate force and torque feedback. Subjects' ability to determine the location of a real object was also examined in order to establish the effectiveness of the hardware and software utilized in the study. In order to obtain their best performance, subjects were trained in each case with correct-answer feedback.

Results indicate that the most significant improvement in perception occurred during the first training session. The accuracy of subjects' haptic perception of virtual object location was the same as the perception of real object position when full force and torque feedback were provided, thus validating the realism of the simulated haptic environment. Estimated percentage JND for these conditions, ranged from approximately 20% for the nearest objects to 12% for the farthest objects. The information transmitted (IT) for these conditions were also the same, at approximately 1 bit (out of a maximum of 2.81 bits). When subjects probed the virtual object by rocking against it, thus freely changing the orientation of the rod, even with forces reflected only at the front tip of the stylus, performance was the same as when true force and torque feedback were provided. However, when subjects were permitted only to tap the probe against the object, thereby limiting the motions and orientations of the rod, providing force feedback only at the tip of the stylus resulted in poor identification of object location. In this case, percentage JND ranged from 37% to 27%, while IT was .17 bits. Torque feedback and object contact with multiple probe orientations, then, provide equivalent haptic information in terms of determining object position. Denying both results in inaccurate haptic perception of object distance.

Thesis Supervisor: Mandayam A. Srinivasan

Title: Principle Research Scientist, Department of Mechanical Engineering



## Acknowledgements

I wish to express my thanks and appreciation to all the people who have made this thesis possible, both those directly involved in my research as well as those whose guidance and support helped me to reach graduate school in the first place.

I would like to thank my advisor, Srini, for introducing me to such an interesting field. In a short year and a half, I have been exposed to many exciting areas of research and learned many things that I never expected to have the opportunity to explore.

My thanks to all the members, past and present, of the Touch Lab. At one time or another, each one has aided me in my research. Especially Chih-Hao and Wan-Chen who taught me the ropes of programming haptic virtual environments, and Raju for patiently answering my countless questions. You're right, Raju, there isn't anything Matlab can't do.

My love and thanks to my family. Mom and Dad, for their unwavering support and the weekly reminder to eat well and take care of myself; my sister, Lisa, and her husband, Babak, my advisors long before I reached MIT; and my brother, Henry, for...I don't know, being my brother, I guess.

I wish to thank my friends, many of whom I neglected during my academic pursuits. It'll never happen again. I would especially like to thank Kristina and Carina, my links to the world outside of studying, experimentation, and writing; and Ted, who since the fifth grade, has provided me with a source of competition that motivates me to work harder.

And finally, I would like to thank the Mass. Ave. food truck and LaVerde's Market for providing my daily sustenance for the last year and a half.

This research was funded by the Office of Naval Research, grant N0001497-1-0635.



# Table of Contents

<b>Chapter 1: Introduction</b> .....	<b>11</b>
1.1 Virtual Environments.....	11
1.1.1 Hardware for Haptic Interfaces .....	11
1.1.2 Software for Haptic Rendering.....	15
1.2 Haptic Perception.....	16
1.2.1 Real World Experiments .....	16
1.2.2 Haptic Perception in VEs .....	17
1.2.3 Torque Feedback Issues in Haptic VEs.....	19
1.3 Organization of Thesis.....	20
<b>Chapter 2: Experimental Design</b> .....	<b>21</b>
2.1 General Method.....	21
2.1.1 Experimental Setup.....	22
2.1.2 Software.....	23
2.1.3 Experimental Conditions .....	24
2.1.4 Procedure .....	26
2.2 Detailed Methods .....	27
<b>Chapter 3: Experimental Results</b> .....	<b>31</b>
3.1 Data Analysis .....	31
3.2 Information Transfer (IT).....	34
3.3 Results.....	35
3.4 Comparison of Performance under different Experimental Conditions .....	55
3.5 Measure of Resolution .....	62
<b>Chapter 4: Discussion</b> .....	<b>68</b>
4.1 Summary of Results .....	68
4.2 Computational Theories.....	69
4.3 Hardware Requirements for Accurate Haptic Perception in VE .....	72
<b>Chapter 5: Future Work</b> .....	<b>75</b>
5.1 Additional Object Distance Discrimination.....	75
5.2 Extension to 6 DOF Experiments .....	75
5.3 Multi-Modal Experiments.....	76
<b>Appendix</b> .....	<b>77</b>
<b>Bibliography</b> .....	<b>87</b>

## List of figures

Figure 1: Force-Feedback Gloves.....	12
Figure 2: "PHANToM" Haptic Interface by SensAble Technology, Inc.....	13
Figure 3: Difference between true torque and torque felt by user.....	14
Figure 4: Two Phantom Configuration.....	14
Figure 5: Point-based vs. Ray-based rendering.....	15
Figure 6: Stimulus positions for a preliminary experiment.....	18
Figure 7: Experimental setup.....	23
Figure 8: Collision detection model.....	24
Figure 9: Effect of reaction force, $R$ , on the subject's hand achieved through forces $F_1$ and $F_2$ applied by the two Phantoms.....	25
Figure 10: Sample plot illustrating the effect of bias on subject response curve....	31
Figure 11: Sample plot illustrating the effect of standard deviation on subject response curve.....	33
Figure 12: Experiment 1: Mean Subject Response.....	37
Figure 13: Experiment 2 (Real Object): Mean Subject Response.....	39
Figure 14: Effect of Training for Experiment 2.....	41
Figure 15: Standard Deviation grouped by training session.....	42
Figure 16: Standard Deviation grouped by object position.....	43
Figure 17: Experiment 3 (True Force and Torque Feedback): Mean Subject Response.....	44
Figure 18: Effect of Training for Experiment 3.....	46
Figure 19: Standard Deviation grouped by training session.....	46
Figure 20: Standard Deviation grouped by object position.....	46
Figure 21: Mean Subject Response according to probing style.....	47
Figure 22: Experiment 4 (Tip Force Feedback): Mean Subject Response.....	48
Figure 23: Experiment 5a (Tip Force Feedback, Rocking): Mean Subject Response.....	49
Figure 24: Effect of Training for Experiment 5a.....	51
Figure 25: Standard Deviation grouped by training session.....	51
Figure 26: Standard Deviation grouped by object position.....	51
Figure 27: Experiment 5b (Tip Force Feedback, Tapping): Mean Subject Response.....	52
Figure 28: Effect of Training for Experiment 5b.....	53
Figure 29: Standard Deviation grouped by training session.....	54
Figure 30: Standard Deviation grouped by object position.....	54
Figure 31: Test Sessions: Mean Subject Response.....	56
Figure 32: Performance under different force display conditions.....	58
Figure 33: Standard deviation under different force display conditions.....	59
Figure 34: Normalized Standard deviation under different force display conditions.....	60
Figure 35: Confusion Matrix for test stage of Experiment 2.....	61



Figure 36: Information Transfer under different force display conditions.....	62
Figure 37: Percentage JND for different force display conditions.....	66
Figure 38: Static force model for determining object position.....	69
Figure 39: Determining object distance based on intersection of two or more probe orientations.....	70
Figure 40: Special case for determining object position based on geometry in which object is used as a fulcrum.....	71
Figure 41: Special case for determining object position based on geometry in which height of object is known.....	72
Figure A1: Experiment 1: Individual Subject Results.....	78
Figure A2: Experiment 2: Individual Subject Results.....	79
Figure A3: Experiment 3: Individual Subject Results.....	80
Figure A4: Experiment 5a: Individual Subject Results.....	81
Figure A5: Experiment 5b: Individual Subject Results.....	82
Figure A6: Confusion Matrices for Experiment 2 (Real Object).....	83
Figure A7: Confusion Matrices for Experiment 3 (Force and Torque).....	84
Figure A8: Confusion Matrices for Experiment 5a (Tip Force, Rocking).....	85
Figure A9: Confusion Matrices for Experiment 5b (Tip Force, Tapping).....	86



# Chapter 1

## Introduction

### 1.1 Virtual Environments

Virtual environments (VEs) are computer-generated worlds in which one or more senses of the human user are stimulated interactively in real time in an attempt to immerse the user in a simulated setting. The wide variety of applications of VEs, ranging from entertainment such as rides and games to training simulations for surgeons or pilots, continues to expand in number and disciplines. The principal component of most current VEs is the graphical display, such as in a head mounted display, aided frequently by auditory stimulation. However, as virtual worlds become more immersive and realistic, there is a need to provide stimulation to senses other than vision and hearing. Advancements in haptic interfaces and rendering methods are beginning to allow the sense of touch to be incorporated in interaction with virtual environments.

#### 1.1.1 Hardware for Haptic Interfaces

Haptic interfaces can generally be divided into two categories: tactile displays and net-force displays (Srinivasan, 1995). A tactile display distributes the net forces and torques that result from contacting an object directly with the skin. Due to the complexities of human tactile sensation, construction of convincing tactile displays is extremely difficult. While this does not deter the continued effort in the development of tactile displays (see Ikei et al., 1997 for a recent example), net-force displays are currently a more practical

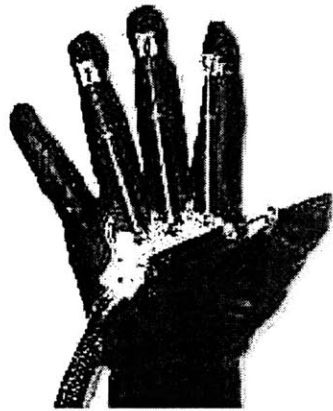

a)

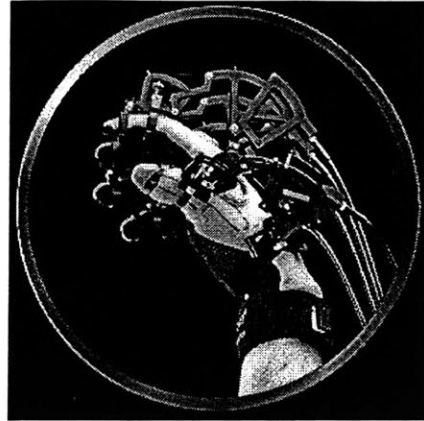

b)

**Figure 1: Force Feedback gloves. a) “RM II” developed at Rutgers University  
b) “CyberGrasp” by Virtual Technologies, Inc.**

means of providing haptic sensations in virtual environments. Net-force displays, or force-feedback devices, simulate the interactions between the user and the environment through an intermediate tool. A variety of net-force displays have been developed and are in use today. There are two basic types of force-feedback devices: body-based and ground-based. Body-based interfaces are exoskeletal devices that are worn by the user. A common type of body-based device is an augmented glove (Figure 1). While such a device provides a large workspace, the calculations required during haptic rendering of virtual objects are very complex. Also, to fully re-produce the physical forces that act on the hand for everyday tasks, the force-feedback glove would require an actuator for every degree of freedom of the hand. Therefore, an interface whose purpose is to stimulate all the joints of the hand would require approximately twenty degrees of freedom (DOF) and additional degrees of freedom if the mobility of the wrist is taken into account. At present, achieving the same level of resolution as human perceptual and motor abilities is not possible. In ground-based displays, the reflection of forces through the end-effectors simulates the indirect contact with an object that results from feeling the world through a

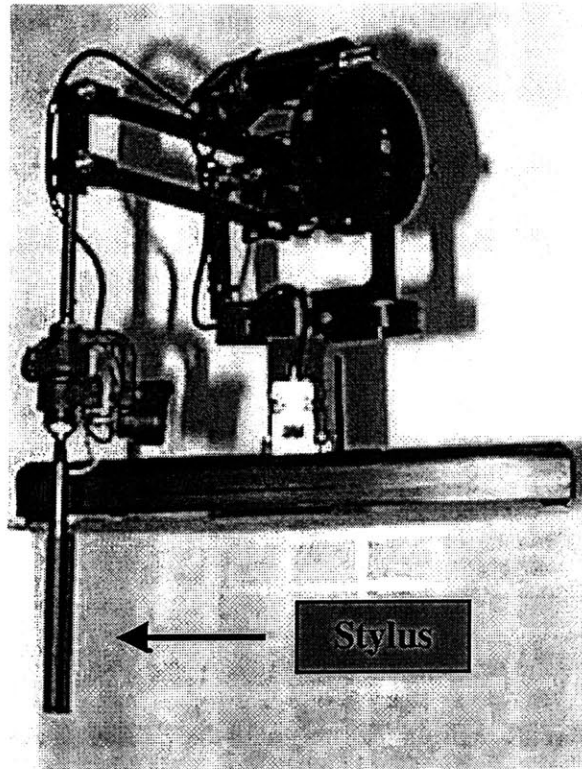

**Figure 2: "PHANTOM" Haptic Interface by SensAble Technology, Inc.**

stick. Types of ground-based displays range from 1 degree of freedom devices that provide force reflection in a single direction (Beaugard and Srinivasan, 1996) to 6 DOF devices that provide force feedback in three directions and torque feedback about three axes (SensAble Technologies). (For a more extensive review of haptic interfaces, see Srinivasan, 1995; Biggs and Srinivasan, 2001). The Phantom haptic interface (Figure 2) designed in the MIT Artificial Intelligence Laboratory (Massie and Salisbury, 1994) provides force feedback in three translational degrees of freedom and position sensing in all six degrees of freedom. In using this device, the user typically grasps the end effector of the device in the form of a stylus and manipulates it as if wielding a stick in order to interact with pre-programmed VEs. The three active degrees of freedom allow the forces to be applied on the user through the tip of the stylus, while the six translational and rotational degrees of freedom allow the user to position and orient the stylus in 3-D

space. Contact between the stylus and an object results in a force and a torque felt by the user's hand. If contact between any part of the stylus other than its tip is made with a virtual object, the torque the user feels at the hand is not physically accurate. The torque the user feels corresponds to contact at the tip of the stylus rather than at the actual point of contact (Figure 3).

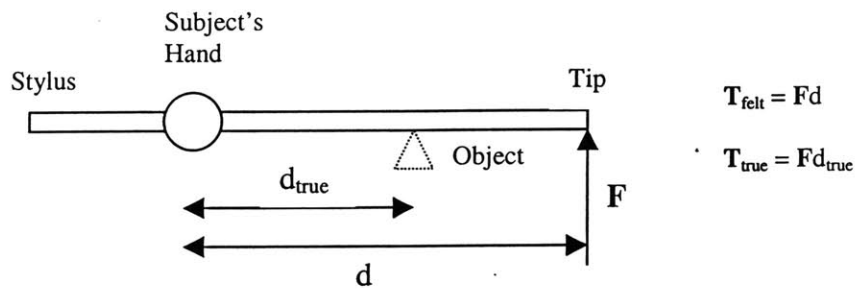

**Figure 3: Difference between true torque and torque felt by user**

In order to present both the true force and true torque for contact at any point along the stylus, the haptic interface used in this study connects two Phantoms with a common probe (Figure 4).

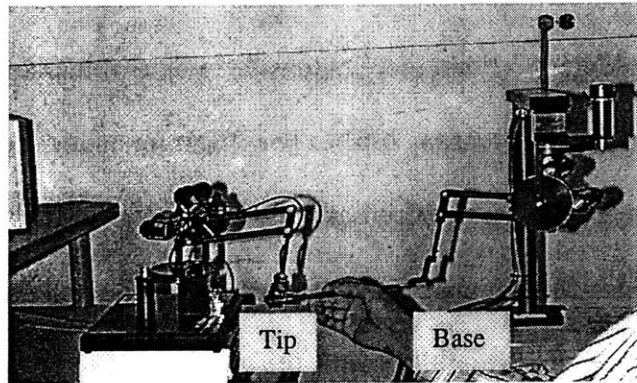

**Figure 4: Two Phantom Configuration**

The main principle used is that the desired combination of force and torque values can be applied at any point on the probe through an appropriate combination of forces acting at the two ends of the probe. This configuration provides five degrees of freedom. Rotation

about the instrument itself is not controllable, though Iwata (1993) presents a solution to this problem by attaching a screw mechanism to the stylus. While this parallel configuration of Phantoms effectively doubles the cost in terms of hardware, it is currently a cheaper and more compact alternative to a single serial manipulator with 6 DOF force and torque feedback.

### 1.1.2 Software for Haptic Rendering

Haptic interaction with objects within virtual environments is defined by the software and requires an algorithm to define the nature of the intersection between the virtual object and the representation of the stylus of the haptic interface. In point-based rendering (Salisbury et al., 1995), the stylus is modeled as a single point. Therefore, regardless of the orientation of the probe, the cursor representing the end-effector of the haptic interface dictates the force reflected to the user. It is possible, then, for unrealistic situations to occur, such as the stylus can be oriented such that its tip is contacting the surface of a virtual object, yet the stylus itself may be passing through the object (Figure 5).

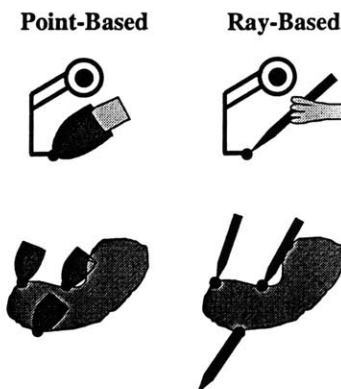

Figure 5: Point-based vs. Ray-based rendering

In many applications of haptic interfaces the interaction of the entire stylus, not just the stylus tip, with the virtual environment is of importance. In these situations, point-based rendering is not an adequate representation of the probe. A ray-based haptic rendering algorithm has been developed to address this deficiency (Basdogan et al., 1997; Ho et al., 2000). In this rendering method, the stylus is modeled as a line segment such that collision detection occurs between objects and the side of the probe as well as at its tip. With this rendering technique, the entire stylus may interact with the VE, providing a more intuitive interface.

## **1.2 Haptic Perception**

### **1.2.1 Real World Experiments**

The sense of touch simulated by most force-feedback devices in VEs today is not experienced directly by the skin; instead, the interaction takes place between a hand-held probe and the environment. Several studies have been conducted on haptic perception through probing of real objects. For example, Chan and Turvey (1991) investigated the mechanical parameters that influence the perception of the height of a surface through dynamic touch. The rotational inertia of the probe, the orientation of the surface, and the distance between the point of contact with the surface and the probe's center of percussion were discovered to be factors that affect perception of the distance between the surface and the user's hand. Quantitative results in the form of power laws were found for perceiving distances of probed surfaces as functions of these parameters (Carello et al., 1992). Perception of roughness and textures through probing was studied by Klatzky and Lederman (1999). Two probes, whose tips differed in diameter, were



used to explore textures consisting of collections of raised dots. Results were compared with perception with a bare finger. Perception of textures when using the probes was not as sensitive as perception when using a bare finger. However, some discrimination of roughness was possible even when the probes were used. Further experiments examined the effects of speed of probing on perceiving roughness through a probe (Lederman, et. al. 2000). Other related investigations revealed the effects of probe diameter and density (Chan, 1995) and method of manipulation and prior experience (Chan, 1996) on perception of rod length. While these studies identify the relationships between mechanical properties and haptic perception, it remains unclear what the role of torque is when these mechanical parameters, such as probe properties, are fixed and object position is the only variable. Also, all of these experiments were performed in the real world and while virtual environments can achieve a suspension of disbelief, VEs do not perfectly mimic reality. Therefore, study of haptic perception of physical objects alone cannot provide sufficient information on how virtual objects are perceived.

### **1.2.2 Haptic Perception in VEs**

In order to determine optimal methods to simulate touch in virtual environments, investigation into haptic perception in VEs must be conducted in addition to understanding haptic perception in the real world. In the real world, the forces, torques, velocities, accelerations, etc. that result from the interactions between objects are dictated by physics and cannot be altered. In virtual reality, on the other hand, a programmer defines the physics of the environment. Controlling the laws that govern the interactions

between objects provides a useful tool in investigating human haptic perception in general as well as specifically in virtual environments.

Our focus in this thesis is to investigate the role of torque feedback in the haptic perception of object location. Preliminary experiments examined the importance of torque feedback in VEs for judging object position relative to hand position (Wu, 1999). Using the parallel Phantom configuration and ray-based rendering technique described above, a simple VE was created in which the only object in the environment was an infinitesimally thin vertical plate located below the probe. Object location was varied between three positions: 60 mm forward of the hand, 60 mm behind the hand, or at the hand, as shown in Figure 6.

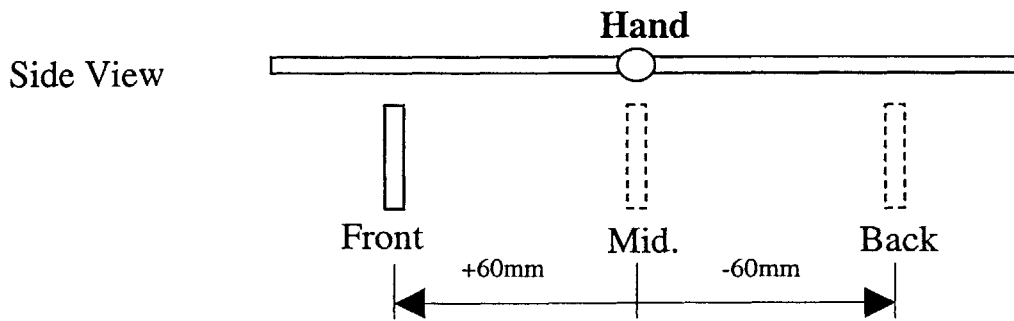

**Figure 6: Stimulus positions for a preliminary experiment**

Under four different force display conditions (tip force only, pure force, pure torque, and both force and torque), subjects were asked to determine whether the object was “front”, “middle”, or “back”. The results of this experiment indicated that under the tip force condition, subjects almost always perceived the object to be forward of the hand, regardless of actual position. In the pure force case, subjects tended to respond that the object was in the middle. Under pure torque, subjects were able to determine when the object was placed forward of the hand or behind the hand. However, when the object was placed directly below where the hand grasped the rod, subjects were not as certain.

In the case where both force and torque were presented to the subject, judgement of the position of the object was quite accurate. These results demonstrate the need for both force and torque feedback when the object can be located anywhere along the probe.

### **1.2.3 Torque Feedback Issues in Haptic VEs**

In most applications, however, the stylus will not be grasped at its center, but near or at its base. The question, then, becomes what is the role of torque feedback when the object is always located forward of the hand. Hancock (1996) suggests that a single 3 DOF force-feedback device is sufficient to perform some of the tasks in which 6 DOF are typically used. Hancock argues that while no true torque feedback is presented by the 3 DOF force feedback haptic interface, the user can voluntarily supply the sense of torque. If this is true, then the cost and complexity of haptic interface hardware and software are considerably reduced. It seems, however, that this voluntary torque can only be supplied in situations in which the user knows, prior to contact, how the probe should respond. This implies a visual representation, which displays the probe and the object, is required as well as prior experience with such a situation. However, this brings up an interesting point: are there conditions in purely haptic virtual environments in which torque feedback is not required? If this is the case, is haptic perception not a function only of the forces and torques experienced during contact, but of other factors (such as user's intent, prior knowledge, arm kinematics, etc.) as well? Is torque feedback providing haptic information that can be presented in another form? Can the same level of haptic perception be maintained if the number of degrees of freedom of the haptic interface is reduced? Answers to these questions ultimately lead to the specification of the hardware

requirements for a haptic virtual environment. However, in order to answer these questions, it is first necessary to identify the information needed for accurate haptic perception within a virtual environment.

### **1.3 Organization of Thesis**

This thesis identifies the conditions in which torque feedback is required in virtual environments by first comparing haptic perception in virtual environments with haptic perception in the real world. Additional studies on identifying the necessary and sufficient information in perceiving the positions of virtual objects are also conducted. Chapter 2 describes the design of experiments, which involved the use of a probe, under various conditions of force and torque display (without visual or auditory stimulation), to contact an object whose position was changed from trial to trial. For example, experiments examining the use of full force and torque feedback versus reflecting only the force at the stylus tip, and tapping versus rocking exploration methods are described. Chapter 3 provides the experimental results and quantitative measures by which subject performance was evaluated. Chapter 4 provides a discussion of the results and conclusions. This includes several models for the possible methods by which object distances are determined. Possible lines for future experimentation are suggested in Chapter 5. Data on individual subject performance can be found in the Appendix.

## Chapter 2

### Experimental Design

#### 2.1 General Method

The exploration and manipulation of objects in virtual reality requires the user to have a sense of how those objects are situated within the environment. Locating objects, then, is a primary task that needs to be accomplished before further interaction with the virtual environment can take place. Therefore, these experiments focus on perception of object position. More precisely, experiments were designed to investigate the role of torque in the haptic perception of the location of virtual objects. Many of the experiments that cannot be conducted in the real world due to the laws of physics can be conducted in virtual environments. Most virtual environments attempt to mimic reality, but this need not always be the case. For example, the programmer can choose to provide the user with only a limited set of haptic cues or create completely non-physical responses to interactions with the environment. In Experiments 4 and 5 (see below), the force displays do not attempt to mimic reality. Instead, for the contact of the probe with a virtual object, the subject was presented with a physically accurate force, but an inappropriate torque. However, while physical laws do not dictate the interactions within virtual reality, there are limitations on what can be presented in a virtual environment due to the state of the hardware and software used to create the VE. Therefore, before examining human perception under non-physical conditions, it was necessary to establish that the imperfection of current virtual environment technology was not a factor in subjects' perceptual abilities. Experiment 3 examined haptic perception in virtual environments in

order to determine how well our rendering technique and hardware configuration simulated reality. Therefore, before experiments were conducted in virtual reality, experiments were run in the real world (see below, Experiments 1 and 2) to determine if subjects were capable of accurate haptic perception of object position in general. In order to ensure that the reasonable comparison could be made between perception in the real world and VE, the highest possible level of consistency for the experiment materials was maintained. Due to limitations in rendering rates, it is currently not possible to simulate perfectly rigid objects in VE. Therefore, the stimulus used for the real object was chosen according to its stiffness to match that of the virtual object. The same probe and hardware setup (see below) were used throughout all experiments regardless of the experimental condition in order to neutralize the effects of varying probe properties, such as rotational inertia, density, etc., on haptic perception.

### **2.1.1 Experimental Setup**

The end-effectors of two Phantom haptic interface devices (Model A1.0 and Model T1.0, each capable of 3 DOF force feedback) were connected by a hollow aluminum rod 54 cm in length. The object, whose location was to be determined by subjects wielding the rod as a probe, was either a prism-shaped rubber eraser or in the case of a virtual object, a thin vertical plate. A large cardboard box and cloth screen hid the apparatus and experimenter from the subject (Figure 7). A cross was cut into the cloth screen such that the subject could reach through and grasp the probe, while still keeping the apparatus hidden from view. A tape measure ran along the side of the cardboard box for the subject to indicate, by pointing, where he/she perceived the object to be. Pointing to the



**Figure 7: Experimental Setup**

perceived object location provided subjects with a physical reference point to judge the position of the stimulus rather than merely choosing a numerical abstraction. The subjects wore headphones to mask the sound of contact between probe and object as well as any possible sound coming from the Phantom motors.

### **2.1.2 Software**

A software program, written in C++, provided control of the virtual environment, presentation of correct-answer feedback (for some trials, see below) and recording of results. Software functionality included: collision detection between probe and object, control of force output for both Phantom haptic interfaces, random positioning of virtual objects, on-screen messages, and data recording. Raw data consisted of subject responses for each trial. While data from all experimental trials were recorded, trials in which the probe was not moved and oriented in accordance with the experimenter's instructions

were tagged and not included in the analysis. The collision detection model for this virtual environment, which consists of a single virtual object and the probe, is shown in Figure 8.

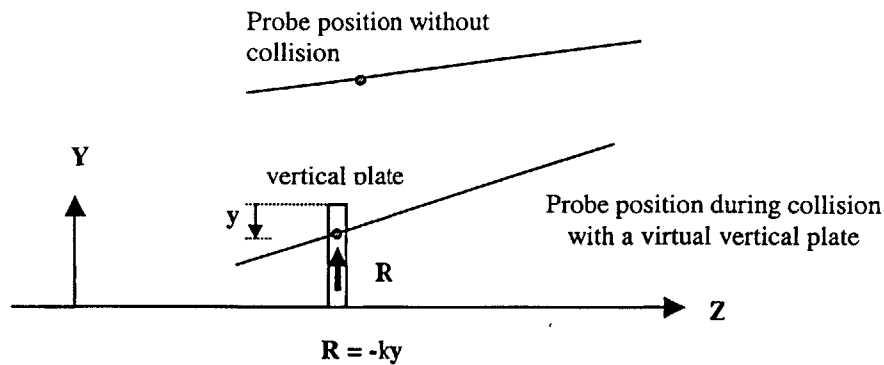

**Figure 8: Collision detection model**

The reaction force due to contact between the probe and object,  $R$ , is computed from Hooke's Law,  $R = -ky$ , where  $k$  is the stiffness of the object and  $y$  is the vertical depth of penetration of the line segment past the top of the plate. The simplicity of this virtual environment enabled us to achieve high rendering rates of up to 15000 kHz. However, due to the length of the probe and limitations of the encoder resolutions in the haptic interface, some vibrations were felt through the probe during contact with the virtual object. To minimize these vibrations, the stiffness of the virtual plate ( $k = 6.4\text{N/mm}$ ) was optimized according to the experimenter's judgement.

### 2.1.3 Experimental Conditions

Three different force display conditions were implemented.

1. Neither Phantom provided force feedback. The haptic cues presented to the subject resulted from actual contact between the probe and the physical object.



2. Both Phantoms provided force feedback. The haptic interfaces simulated the presence of an object by reflecting both the true forces and torques whenever the probe intersected the virtual object.
3. A single Phantom provided force feedback. Contact between the probe and the virtual object resulted in force reflection only at the Phantom connected to the tip of the probe (i.e. the torque feedback experienced by the user was physically inaccurate).

The position encoders of both Phantoms were active during all trials, however, in order to monitor the position and orientation of the probe.

Conditions 2 and 3, both of which involved interaction with virtual objects employed the following force computations (Figure 9):

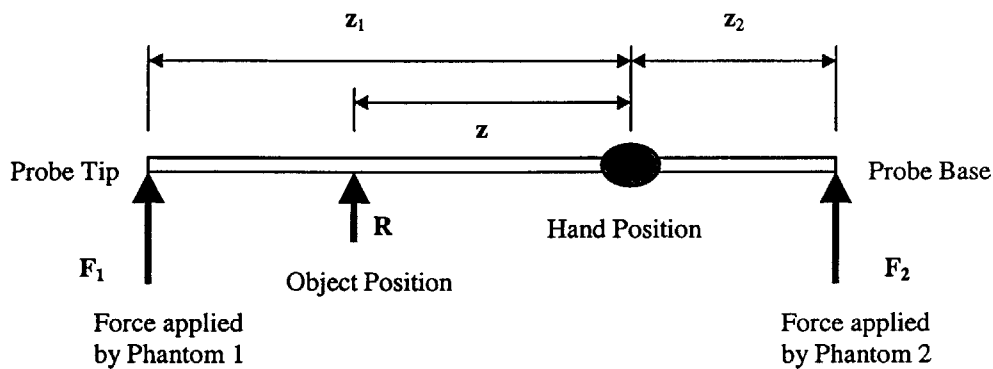

**Figure 9: Effect of reaction force,  $R$ , on the subject's hand achieved through forces  $F_1$  and  $F_2$  applied by the two Phantoms.**

**Force and Torque:** The forces applied by the two Phantoms give a resultant force equal to the magnitude of the reaction force,  $R$ , and result in a torque equal to the moment created by that force with moment arm  $z$ .

$$F_1 + F_2 = R$$

$$(\mathbf{z}_1 \times \mathbf{F}_1) + (\mathbf{z}_2 \times \mathbf{F}_2) = \mathbf{z} \times \mathbf{R}$$

Tip Force: This condition is identical to having a single Phantom connected to the tip of probe.

$$\mathbf{F}_1 = \mathbf{R}$$

$$\mathbf{F}_2 = 0$$

Where,  $\mathbf{F}_1$  and  $\mathbf{F}_2$  are forces reflected by the Phantoms connected to the tip and base of the probe, respectively.  $\mathbf{z}_1$  and  $\mathbf{z}_2$  denote the relative displacements from the hand to Phantoms 1 and 2.  $\mathbf{R}$  is the reaction force computed from Hooke's Law ( $\mathbf{R} = -ky$  as in Figure 9) and  $\mathbf{z}$  is the displacement from the hand to the point of intersection of the object with the probe.

#### 2.1.4 Procedure

Subjects were asked to sit in a chair facing the computer monitor such that he/she could comfortably grasp and manipulate the rod with the right hand. The rod was grasped as one would a pointer. A piece of tape on the rod indicated where the subject was to grip the probe so that hand position was kept constant for all trials, experiments, and subjects. Instructions to subjects varied by experiment. However, in all cases, the subject was asked to grasp the probe and in a specified manner (see below) make contact with the object. Subjects were permitted as much time as they needed to determine the position of the object. The position of the object was fixed in each trial, but was changed randomly from trial to trial. To simplify the problem, rather than placing the object randomly in 3-dimensional space, only the z-component of the object position was varied. (Axes orientations are such that the z-axis is the longitudinal axis of the probe when it is parallel

to the ground, the y-axis is perpendicular to the z-axis and vertical, and the x-axis is perpendicular the z-axis and horizontal). In each trial, the subject was asked to judge the absolute position of the object by pointing to the tape measure. There were a total of ten sets of trials for each experimental session. The number of sessions varied for each experimental condition, depending upon the amount of training provided (see below). A total of twenty trials for each stimulus per experimental condition were presented to each subject. In addition, one practice set was given to the subjects at the beginning of each session.

## **2.2 Detailed Methods**

### **Experiment 1: Real Object (4 object positions; restricted probing)**

Experiments 1 and 2 made use of the first force display condition (i.e. forces and torques experienced by subject were from contact with a prism-shaped rubber eraser). In Experiment 1, the object was placed at four different object positions between 24 and 36 centimeters forward of the initial hand position at 4 cm increments. Subjects were instructed to hold the rod oriented horizontally and tap the object through pure vertical motion of the rod. Subjects were notified by messages on the computer screen when the rod moved outside a longitudinal range of  $\pm 3$  mm. Seven naïve subjects from the MIT community ranging in age from 18 to 31 were paid to participate in this experiment. All subjects were right-hand dominant.

### **Experiment 2: Real Object (7 object positions; unrestricted probing)**

In Experiment 2, in order to determine the effects of learning on haptic perception, subjects were trained using correct-answer feedback. As in Experiment 1, a prism-

shaped rubber eraser was used as the stimulus. In this experiment and in the remaining experiments, the object was located at seven different object positions between 9 and 33 centimeters forward of the initial hand position at 4 cm increments. In order to obtain their optimal performance, subjects were permitted to use any exploration method they chose, so long as the probe remained approximately in the vertical plane. Training occurred in three stages. In the first stage, the subject's initial performance was measured. No correct answer feedback was given to the subject. This stage provided a baseline performance with which the subsequent results could be compared. In the second stage of training, the same object and the same set of object positions was presented to the subject, this time with correct-answer feedback following each trial. Subjects completed a total of four sessions of these experiments. The final step in the training was a repetition of the first stage. The purpose of this third phase was to measure the performance of these experienced subjects following extensive practice. Eight naïve subjects from the MIT community ranging in age from 18 to 27 were paid to participate in this experiment. All subjects were right-hand dominant.

**Experiment 3: Virtual Object (True force and torque feedback; unrestricted probing)**

After testing the ability of subjects to distinguish different object positions when using real objects in Experiments 1 and 2, Experiment 3 investigated haptic perception of virtual objects. Experiment 3 made use of ray-based rendering (see –Sections 1.1.2 and 2.1.2) and force reflection at both the tip and base of the probe, effectively providing the subject with both force and torque feedback as one would expect from the physics of contacting a real object. In this experiment, subjects were trained as in Experiment 2.

However, subjects completed only one session with correct-answer feedback rather than four sessions as in Experiment 2, whose results indicated that the additional correct-answer feedback sessions produced minimal improvement (See Section 3.3). Subjects were permitted to use any exploration method they chose, so long as the probe remained in the vertical plane. However, the subject was asked to limit his/her longitudinal range of motion to +/- 30 mm of its starting position. Subjects were notified by messages on the computer monitor if the motion of the probe exceeded this range. Six of the eight subjects that participated in Experiment 2 took part in this experiment.

**Experiment 4: Virtual Object (Tip force only; unrestricted probing)**

In order to determine the role of torque in haptic perception, Experiment 4 examined subject performance under the limited force display condition of having only force feedback at the tip of the probe. The torque experienced by the subjects depended only on the force and not on the position of the object as it did in Experiment 3. Thus torque provided misleading information about object position.

**Experiment 5: Virtual Object (Tip force only; restricted probing)**

Subjects were trained under this force display condition using two different modes of exploration: rocking (Experiment 5a) and tapping (Experiment 5b). Again, subjects were limited to a longitudinal range of +/- 30 mm of the starting position.

***Experiment 5a: Rocking***

Exploration was restricted to rocking the probe against the object. However, subjects were allowed to re-position the probe relative to the object as they chose (i.e. using

different pivot points along the probe). Taking Experiment 4 to be initial subject performance, Experiment 5a consisted of a single correct-answer feedback session and a test session. The same six subjects that participated in Experiments 3 and 4 took part in Experiment 5a.

Experiment 5b: Tapping

The method of exploration was restricted to tapping against the object such that the probe always struck the object with the same orientation. As in Experiment 5a, training consisted of one correct-answer feedback session and a test session. Five of the six subjects that participated in Experiment 5a took part in this experiment.

## Chapter 3

### Experimental Results

#### 3.1 Data Analysis

Figure 10 provides a sample plot of several possible subject responses versus actual

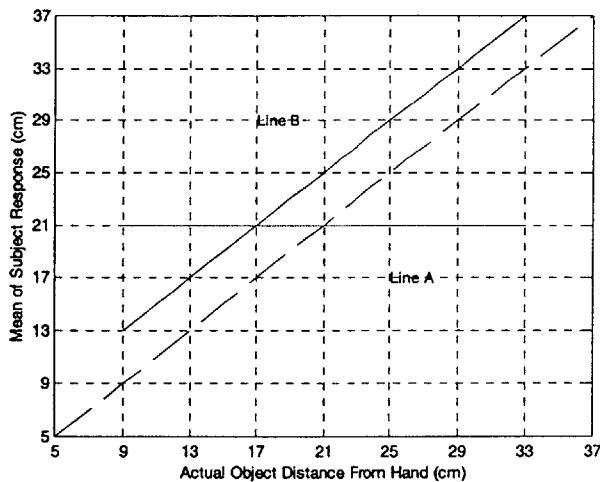
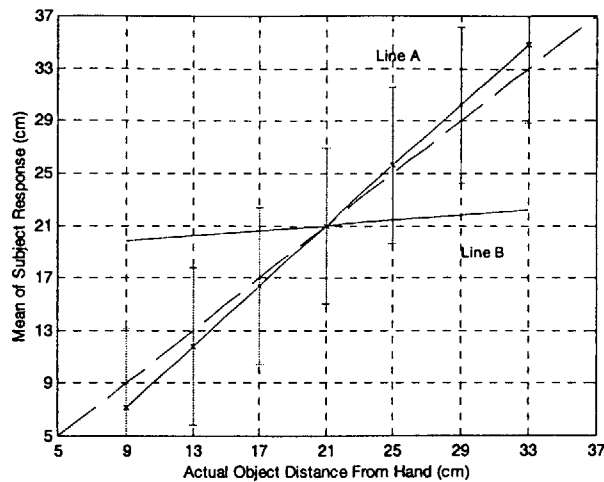

**Figure 10: Sample plot of mean subject response. Line A shows zero offset and zero slope. Line B shows unity slope and finite offset.**

object position. The object positions are measured according to their initial distance from the hand before the subject begins probing, which is constant for each trial. The dotted line represents perfect identification of each object position for every trial. From the results, below, it can be seen that the data points, which are the mean of all responses for a given stimulus (object distance) averaged across all subjects, are monotonically increasing with object distance and approximately linear (in general, the mean responses actually form an S-curve). The line segments represent sample best-fit straight lines (to be referred to as the mean subject response) through these data points. The slope of the

mean subject response, then is a measure of subjects' ability to locate each object, within the stimulus set, relative to the hand. A zero slope (i.e. a horizontal line) as shown in the figure by Line A, implies that regardless of the actual position of the object, the subject perceived the object to be at the same position for every trial. A non-zero slope indicates that the subject can distinguish between different object positions. As seen in Figure 10, the slope of the ideal performance trace is unity. Therefore, the closer the slope of the subject response curve is to unity, the better the subject is able to identify the position of the object. A slope larger than unity means that the actual relative distance between objects is smaller than what was perceived, whereas a slope less than unity indicates that relative distance between objects is larger than what was perceived. The slope of the mean subject response, however, does not completely characterize subjects' perceptual ability. For example, in Line A of Figure 11, the mean subject response lies very close to the ideal performance line. However, imagine that subject responses for each stimulus was distributed over a large range of values (the variance associated with the mean response for each stimulus is described by the standard deviation and indicated by the vertical bars). While the mean response would accurately locate the object, any single response could lie anywhere within that range of distances and would likely not be as accurate. This scatter is due both to variability across subjects as well as inconsistencies in individual subject responses for the same stimulus. If, on the other hand, the mean subject response has a very shallow slope (Line B in Figure 11), but there is no standard deviation associated with any of the mean responses, one could conclude that each object position was perfectly distinguished from the others, but the absolute positions were poorly judged. Therefore, the standard deviation indicates the level of confidence





**Figure 11: Sample plot of mean subject response. Line A shows finite standard deviations with accurate mean response. Line B shows shallow slope with no standard deviations.**

associated with the mean response (i.e. indicates how well the object positions were consistently discriminated). Another important measure of performance is bias. Where the slope of the mean subject response line gives an indication of how well subjects perceived object distances within a group of objects, bias shows us how well subjects perceived the position of the group of objects as a whole (i.e. how the entire set of subject responses is shifted with respect to the set of actual object locations). The bias is computed by taking the average of the difference between the mean subject response curve and the ideal performance curve. Therefore, the units of bias is centimeters. Mathematically, this value is equivalent to the vertical offset of the midpoint of the mean subject response line segment from the ideal performance line. A positive bias denotes an average underestimation of object distance on the part of the subject, while a negative bias indicates an average overestimation. Line B in Figure 10 shows an example of a subject with perfect identification of objects within the set of stimuli, but with a negative bias. Ideal performance can be characterized as having unity slope with no standard deviation and zero bias.

### 3.2 Information Transfer (IT)

Another way to look at subject performance makes use of information theory. Due to the correct-answer feedback sessions and the fact that the same seven object positions were used throughout these experiments, the task of determining the object distance ultimately falls under the absolute identification paradigm. In other words, for a set of  $k$  stimuli  $S_i$ ,  $i = 1..k$ , and a set of  $k$  responses  $R_j$ ,  $j = 1..k$ , there is a single correct response,  $R_i$  for stimulus  $S_i$ . A confusion matrix can be constructed in which the entry in row  $i$ , column  $j$  indicates the number of times that the response  $R_j$  was given for stimulus  $S_i$ . Information transfer can then be calculated according to the entries in the corresponding probability matrix (Garner and Hake, 1951) in which each cell contains the frequency with which response  $R_j$  was given for stimulus  $S_i$ . The amount of information that is contained in the occurrence of an event, in this case a particular response for a given stimulus, is dependent upon the total number of possible responses. The amount of information is actually equivalent to the uncertainty that the event will occur. For example, if there is no uncertainty as to the occurrence of an event, no information is gained when that event happens. If, on the other hand, there are a number of equally possible responses for a given stimulus, then the occurrence of one particular response provides more information. The measure used to quantify the amount of information or uncertainty is the logarithm to the base two of the probability of the occurrence of an event. The resulting units for this measure of information are bits.

### **3.3 Results**

#### **Individual Subject Performance**

Most of the results reported in the following sections of this thesis have been averaged across a number of subjects, which ranged from 5 to 8, depending on the experiment. However, it should be noted that not all subjects had the same perception of the object distances. In fact, looking at the mean response for each of the 7 individual subjects for Experiment 1 in Figure A1 of the Appendix, we see that no subject could accurately locate the objects and no two subjects agreed on the distance of the stimuli. While Subjects 2, 3 and 4 each perceived, on average, that each of the stimuli were located at the same distance from the hand (indicated by the horizontal slope), there was more scatter in Subject 4's responses as shown by the larger standard deviations. Both Subjects 2 and 3 were more consistent in their responses with standard deviations of approximately 2 cm for each stimulus, however, the bias for Subject 3 is 8 cm larger than that of Subject 2. Subject 6's mean responses were fairly accurate as shown by the near unity slope, however, the large standard deviations (at least 5 cm and for the two farther stimuli, greater than 10 cm) indicate that there was little consistency or confidence in any single response. Subject 7 was unable to properly order the stimuli as shown by the staggered nature of the responses for the different object distances. This large range of responses from the different subjects is not unreasonable for Experiment 1. Without correct-answer feedback and no prior experience, naïve subjects could respond to any one stimulus with any position in a continuous range of 60 cm (size of the box hiding the apparatus). However, examining the mean response of the 8 subjects for the final stage of Experiment 2 (i.e. the test session for real object force display condition, see Section

3.3) in Figure A2 of the Appendix, shows that there is still a large degree of variation across subjects following training with correct-answer feedback. The responses of Subjects 2, 6 and 9 followed pronounced S-curves, whereas the S-curves traced by the responses of Subjects 3, 5 and 8 were less prominent and the responses for Subjects 10 and 12 were almost linear for increasing stimulus distance. In terms of vertical offset (bias), Subject 8's perception of object distance was the closest to ideal performance. Subject 8 underestimated the object positions as a group by .31 cm. Subjects 3 and 9 each had offsets of 2.09 cm, however where Subject 3 underestimated stimulus distance on the average, Subject 9 overestimated. Offset is an easily corrected characteristic with correct-answer feedback, however. It indicates that subject perception of the set of stimuli as a group was shifted relative to their actual positions. When correct-answer feedback is provided, subjects can adjust their mapping of the object space accordingly. While Subjects 3 and 9 had the most significant offsets, they were able to accurately distinguish the different object positions relative to the other stimuli as indicated by the near unity slopes and small standard deviations. Subject 6, on the other hand, had a smaller offset, but the slope of the response line was much shallower (.65 slope) and farthest from unity among the 8 subjects. While this subject was able to shift the mapping of the stimuli as a group to be closer to the actual object positions than Subjects 3 and 9, within the set of object positions, was unable to accurately perceive the relative distances. In this regard, Subject 5 had the best performance. The slope of the mean response line for Subject 5 was unity, indicating that, on the average, the perceived relative distances between object positions within the stimulus set matched the actual distances between the stimuli (4 cm). The slope of the mean response line for each of the

subjects was less than or equal to unity aside from Subject 9 (1.04). The slopes for 5 of the 8 subjects were within 6% of each other and included the slope for the average response across all subjects (Figure 13f, below). This indicates that there was not a lot of variation in slope across subjects. Subject 6 is the only significant exception. Subject 2 had the largest average standard deviation of 4.94 cm. The average standard deviation for Subject 12, who had the smallest scatter for each stimulus, is more than 1 cm smaller than that of the average across all 8 subjects (2.17 cm versus 3.23 cm, see below), and more than 2 cm smaller than the average standard deviation for Subject 2 (4.94 cm). This indicates that there was some variation across subjects in the scatter of responses for the different stimuli.

**Experiment 1: Real Object (4 object positions; restricted probing)**

Figure 12 shows mean response as a function of actual object position averaged over all subjects for Experiment 1 with one-sided error bars showing one standard deviation from the mean.

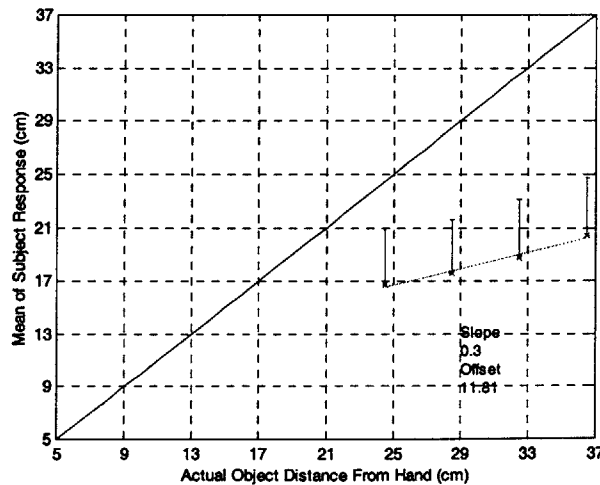

**Figure 12: Experiment 1: Mean Subject Response**

A large discrepancy is seen between the actual location of the object and where subjects perceived the object to be. The .30 slope indicates that for two adjacent objects placed 4 cm apart, subjects perceived only a 1.2 cm separation ( $.30 * 4\text{cm}$ ). The standard deviations for each stimulus ranged from 3.98 cm to 4.34 cm. The positive bias of 11.81 cm shows that, on the average, subjects underestimated the object group location by nearly 12 cm. No information transfer was computed for Experiment 1 as it was not an absolute identification experiment. No correct-answer feedback was given to the subjects. Therefore they were unaware of the actual position of the objects.

**Experiment 2: Real Object (7 object positions; unrestricted probing)**

Figure 13 shows mean subject response for each stage of the training for Experiment 2. Initially, before any correct-answer feedback was given to the subjects, perception of object distance was not very accurate or consistent. While the monotonic increase in perceived position indicates the ability to properly order the stimuli by distance, the slope of .63 in Figure 13a implies that, on the average, a 2.52 cm distance between objects was perceived for an actual separation of 4 cm. The average standard deviation for the seven object positions was 7.49 cm, which tells us there was a large degree of scatter for each stimulus. Figure 13b shows subject response for the first correct-answer feedback session. A drastic change in subject perception is seen between the initial training stage and this first feedback session. Slope improved from .63 to .89 and bias decreased in magnitude from 3.41 cm to .28 cm. There was also a decrease in the standard deviations for each stimulus (the average dropping to 4.53 cm), indicating more consistent responses for a given object distance. A relatively smaller improvement resulted from the next

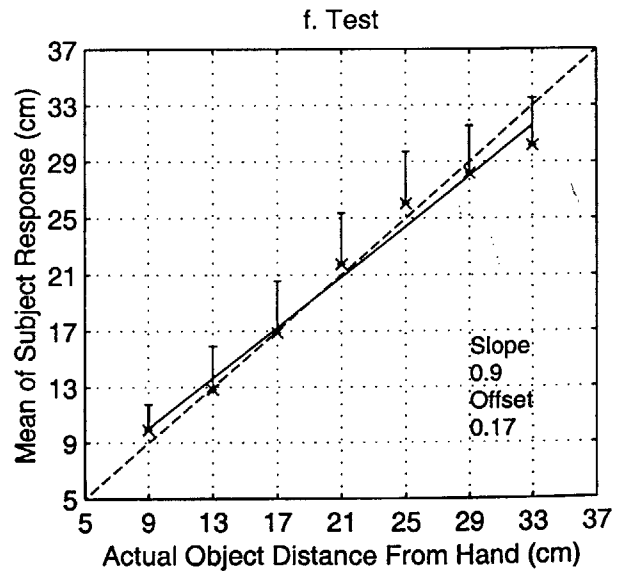
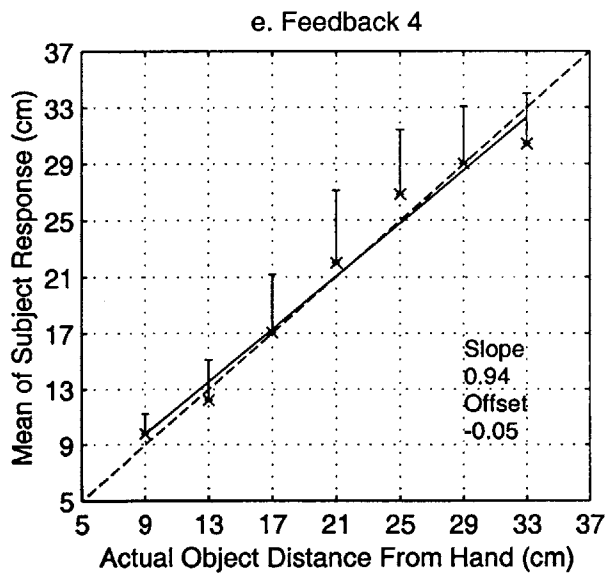
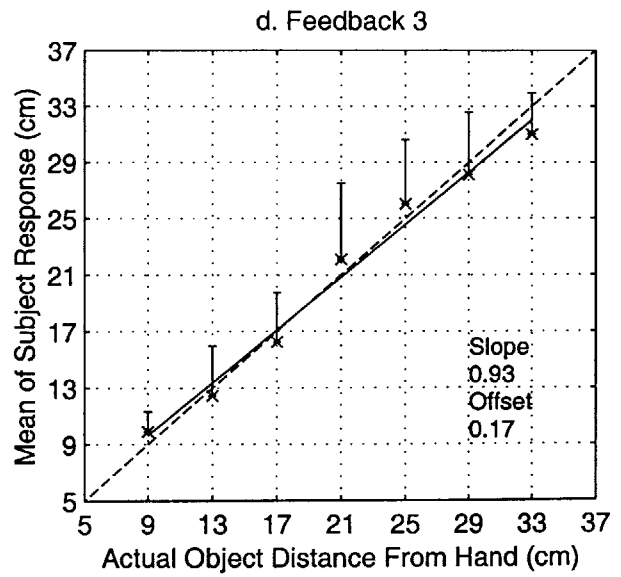
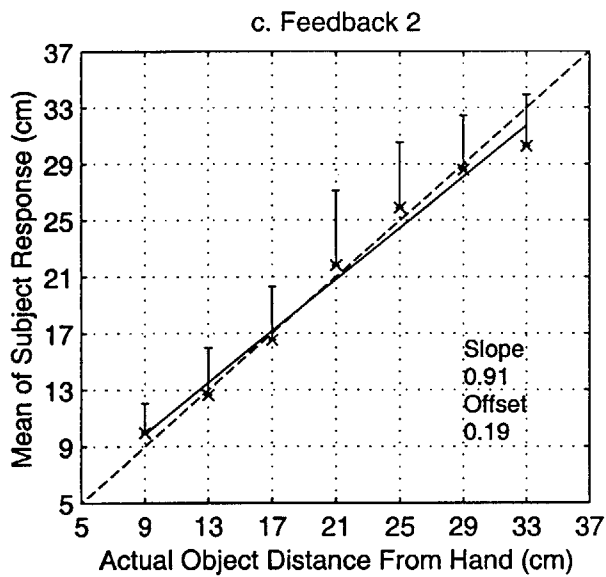
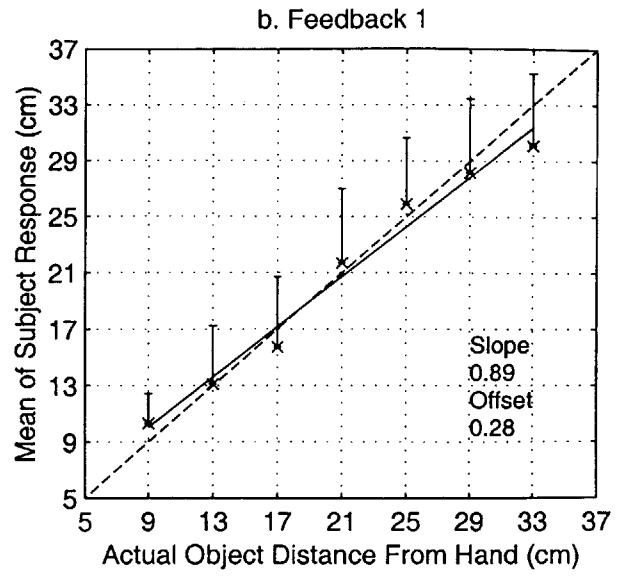
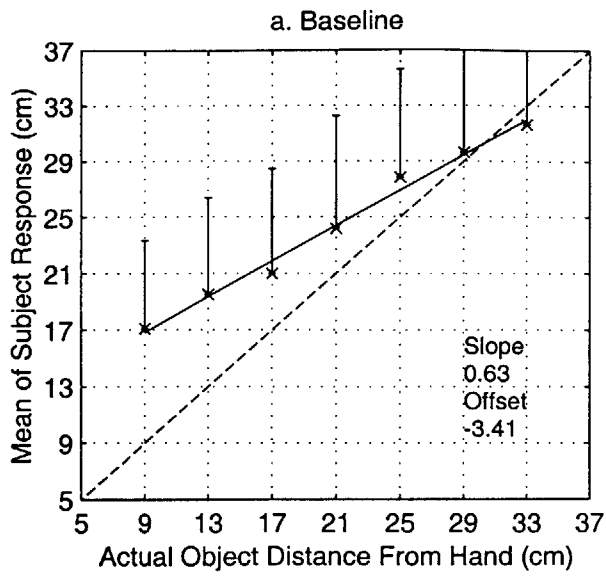

Figure 13: Experiment 2 (Real Object): Mean Subject Response

feedback session, the results of which are plotted in Figure 13c. The slope was found to be .91 and the bias was .19 cm. The average standard deviation also improved to 3.81 cm. Identification of absolute positions continued to improve in feedback session 3 as seen in Figure 13d, though only slightly in comparison to the two previous sessions. The slope of the mean subject response and the bias for the third feedback session were .93 and .17 cm, respectively, while the average standard deviation decreased again, this time to 3.69 cm. There was little change in object location identification between the third and fourth feedback sessions. The slope and average standard deviation for the final correct-answer feedback remained relatively unchanged at .94 and 3.68 cm, respectively, and bias reduced to .05 cm in magnitude. Training through correct-answer feedback proved to be an effective method for improving haptic perception of object distance as indicated by the results for the test stage in Figure 13f by the .90 slope (the 4 cm distance between objects was perceived to be 3.6 cm) and small bias of .17 cm (less than 2 mm underestimation on average). There was also more confidence in each response as seen by the average standard deviation of 3.23 cm. The information transfer was calculated to be 1.05 bits. The 10% difference in slope between subject perception and ideal perception may seem large at first, however, if one realizes that this amounts to only a one-millimeter difference for each centimeter the object is moved, a .90 slope is, in fact, quite accurate. The standard deviation about the mean should also be taken into account. Though the mean response does not exactly match the actual position, it can be seen from Figure 13f that for each stimulus, actual object distance lies within one standard deviation of the mean. Figure 14 shows the effect of training on subject performance, in terms of slope and percentage bias, as a function of the phase of the training, from the initial stage



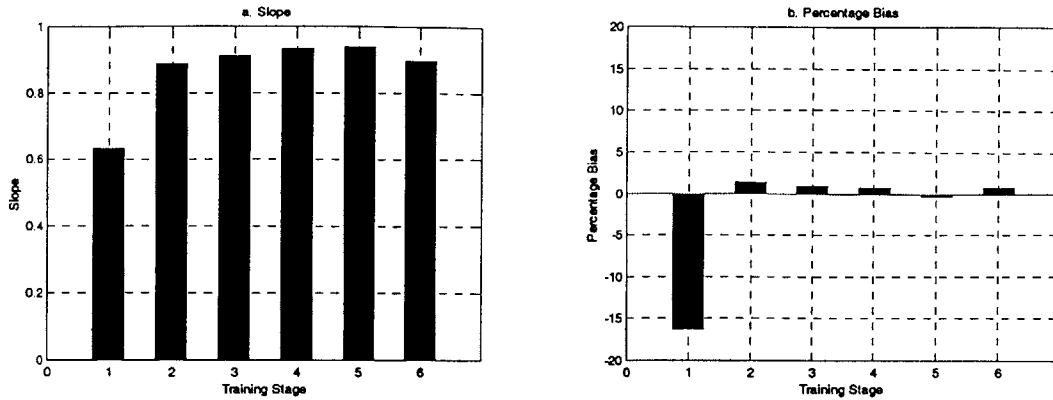
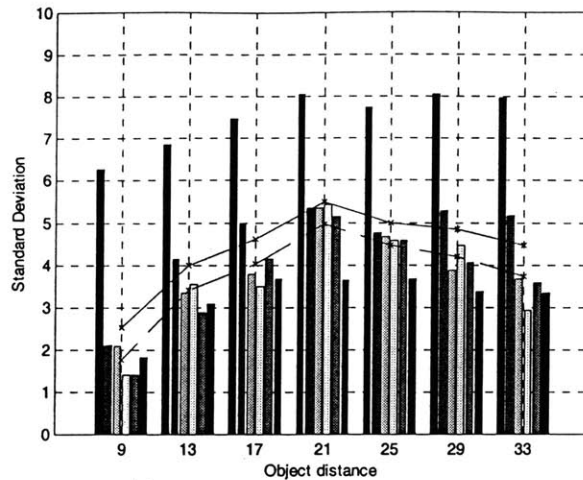

Figure 14: Effect of Training for Experiment 2 (Real Object)

through the four correct-answer feedback sessions, and finally the test stage. The slope increased considerably between stages one and two of training from .63 to .89. In the remaining training stages, the slope did not vary by more than 5%. Percentage bias is the offset of the mean subject response line normalized by the average stimulus distance from the hand (21 cm). As with the slope, the most significant effect of the training took place during the first correct-answer feedback session in which percentage bias decreased in magnitude from approximately 16% to 1%. The percentage bias remained under 1% for the other training stages. Figure 15 shows how standard deviation varied by actual object distance. Within each group is the standard deviation for each training stage. The solid line joins the average value of each group, while the dotted line is the average value of the group, excluding the initial training stage. The standard deviations are lowest for the first stimulus (i.e. the object closest to the hand). This indicates that subjects were able to distinguish this object distance with greater ease than the other positions. The greatest uncertainty in responses (i.e. the largest standard deviations) is associated with the object distances in the middle of the stimulus set. In fact, average standard deviations in each grouping increases with object distance between the first object position until it



**Figure 15: Experiment 2 - Standard Deviation Grouped by Training Sessions**

reaches its peak at the middle object distance, and then decreases with object distance with the remaining stimuli. This trend exists regardless of whether the initial training stage is included in the average. The effect of the baseline experiment merely increases the average by approximately .5 cm. Figure 15 also shows that the effects of training on the consistency of subject response followed approximately the same pattern for each stimulus. In each case, variance in subject response in the initial stage was fairly large (greater than 6 cm), decreased significantly during the first correct-answer feedback session, and decreased slightly and settling to an approximate limit of 3.75 cm in the subsequent feedback sessions before decreasing again in the test stage. This may be more apparent in Figure 16, which groups the standard deviations by object distance and is plotted as a function of training session. The average standard deviation starts high, approximately 7.5 cm, dips considerably after the first feedback session to approximately 4.5 cm, then settles at approximately 3.75 cm for the feedback sessions. Due to these results, the training of subjects for the remaining experiments consisted of only a single correct-answer feedback session separating the initial and test phases. While the

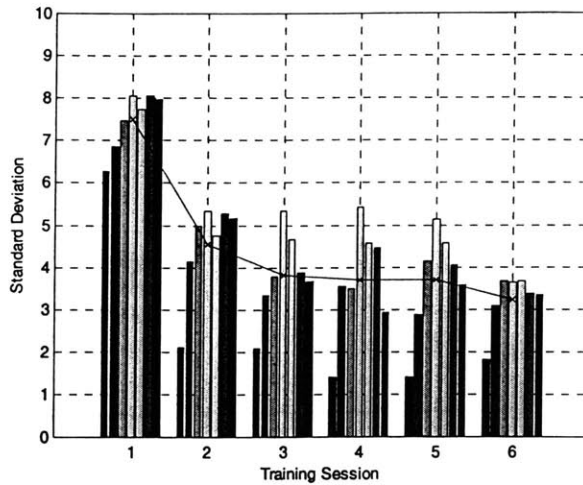

**Figure 16: Experiment 2 - Standard Deviation Grouped by Object Position**

additional feedback sessions led to improvement in subject performance in terms of accuracy and consistency, the change was not significant enough to warrant the extra training.

**Experiment 3: Virtual object (True force and torque feedback; unrestricted probing)**

Figure 17 shows the plot of subject response versus actual position of the virtual object for each stage of the training for Experiment 3, in which subjects were presented with both true force and true torque feedback. Again, perception of object distance prior to correct-answer feedback was not very accurate as seen in the .73 slope, 3.82 cm average standard deviation, and 3.26 cm bias of Figure 17a. As in Experiment 3, there was considerable improvement made during the next phase of training, which provided subjects with correct-answer feedback. The slope of the mean subject response increased to .91, while average standard deviation was reduced to 3.55 cm, and bias decreased to .4 cm. The test stage resulted in a slope of .95, which implies that for objects placed 4 cm apart, on the average, a 3.80 cm separation was perceived. The standard deviation

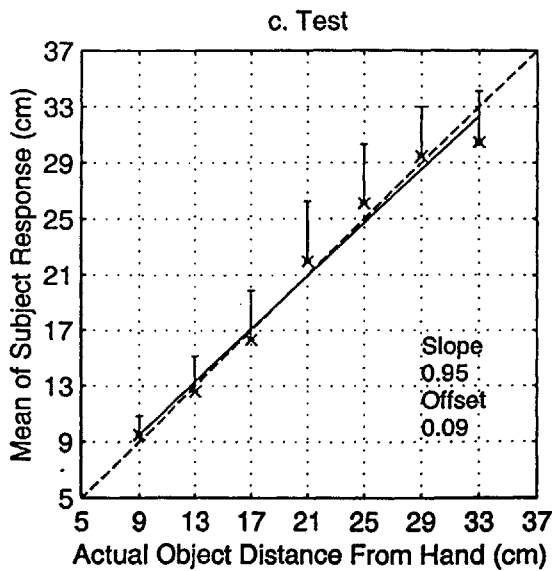
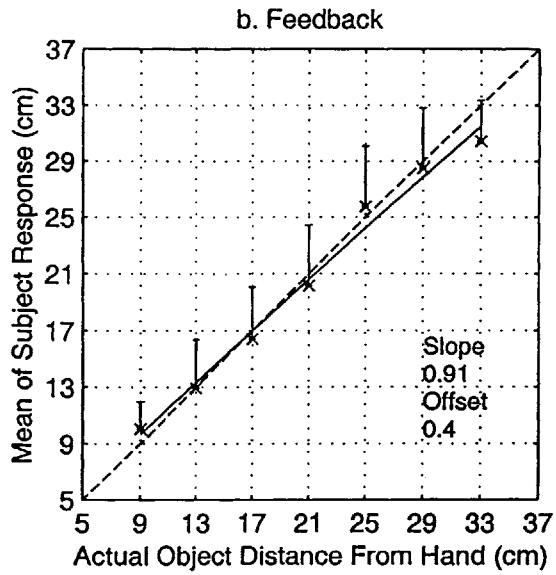
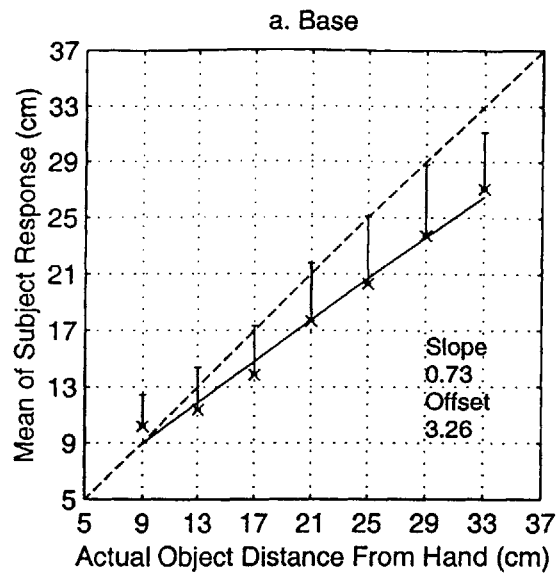
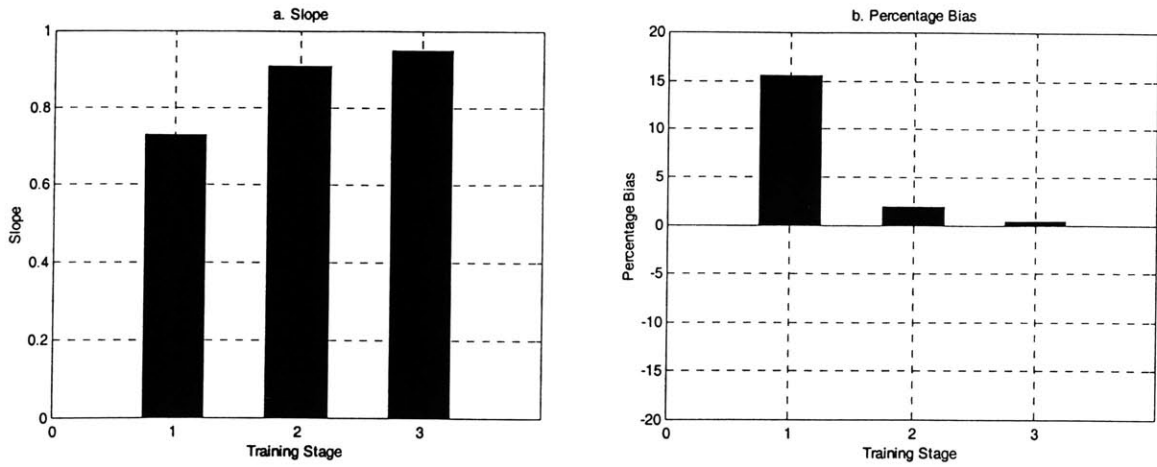

Figure 17: Experiment 3 (True Force and Torque Feedback): Mean Subject Response

decreased to 3.30 cm, suggesting that subjects were more confident of their responses despite no longer receiving correct-answer feedback. The bias of .09 indicates that there was an average underestimation of less than a millimeter for each object distance. The information transfer for this test stage was computed to be 1.16. These results demonstrate the effectiveness of ray-based rendering and the parallel configuration of the two force-feedback devices as haptic perception in the virtual environment was at least as good as haptic perception in the physical world. From Figures 18 and 19, it is seen that slope, average standard deviation, and bias improved for each stage of training. Figure 20 shows the same trend for the average standard deviation as seen in Experiment 2. That is, minimal standard deviation at the extreme object positions and a maximum peak at an intermediate distance.

Note: while subjects were permitted to use any exploration method(s) they chose, observations by the experimenter and comments from the subjects indicated that each of the subjects chose to focus only on one technique. Three of the subjects (Subjects 5, 10, and 12) practiced a rocking method in which the object was used as a fulcrum and the remaining three subjects (Subjects 6, 8, and 9) employed a tapping method. Figure 21 shows that performance in each subgroup was comparable for each stage of the training. In the test phase, there was only a 2% difference in slope and less than 2 mm difference in bias between the two graphs. However, looking at the mean standard deviations, we can see that those subjects in the rocking subgroup responded more consistently on the average. In the test stage, the average standard deviation for the rocking subgroup was 2.72 cm versus 3.88 cm for the tapping subgroup.



**Figure 18: Effect of Training for Experiment 3**

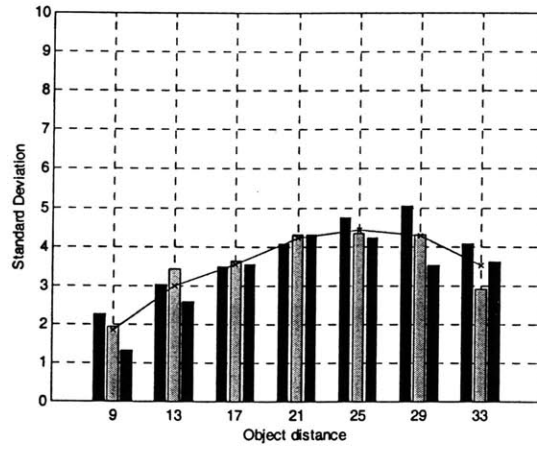

**Figure 19: Standard Deviation Grouped by training session for Experiment 3**

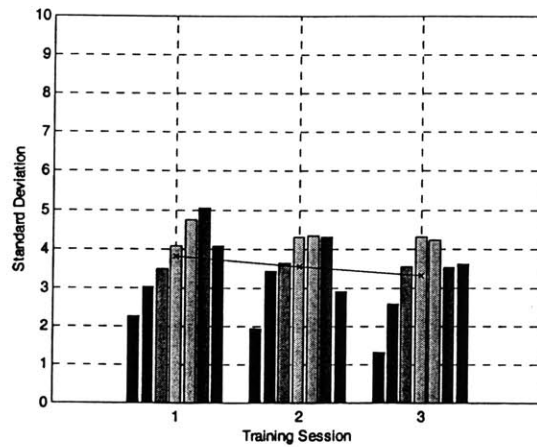

**Figure 20: Standard Deviation Grouped by object position for Experiment 3**

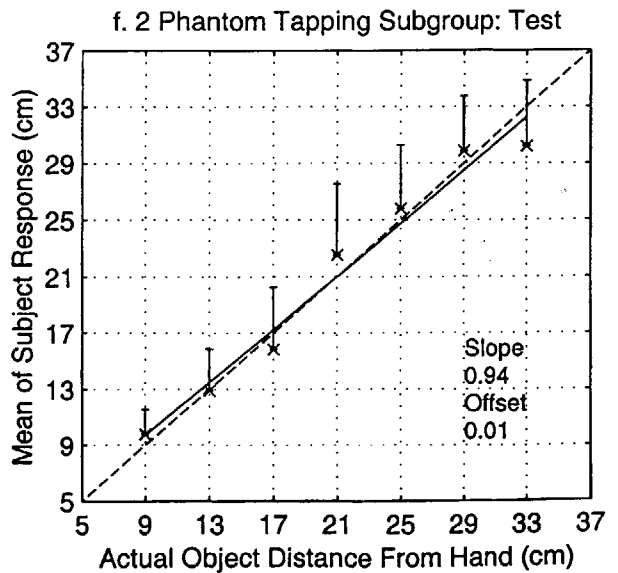
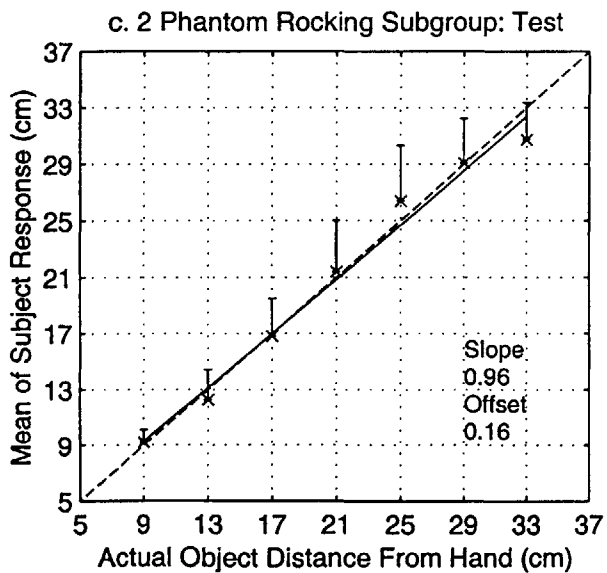
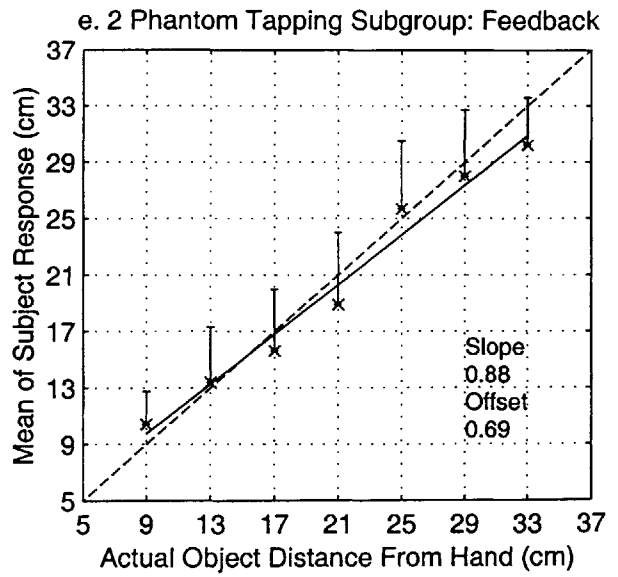
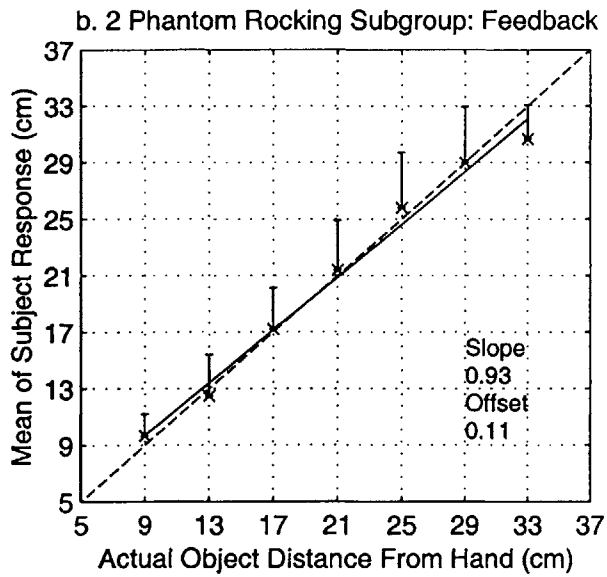
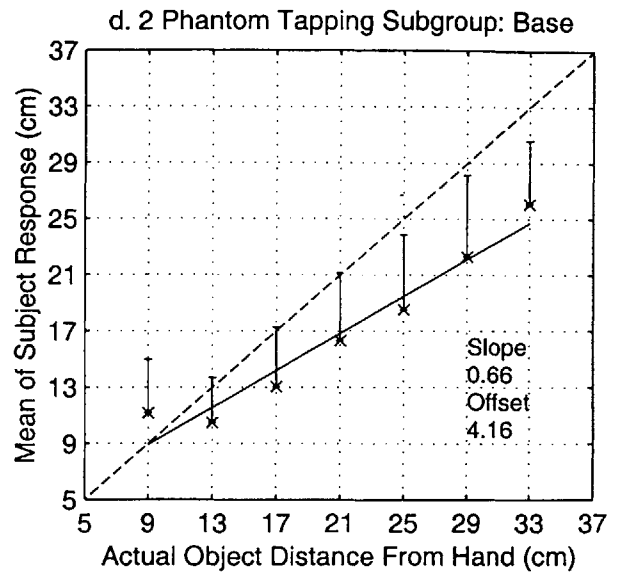
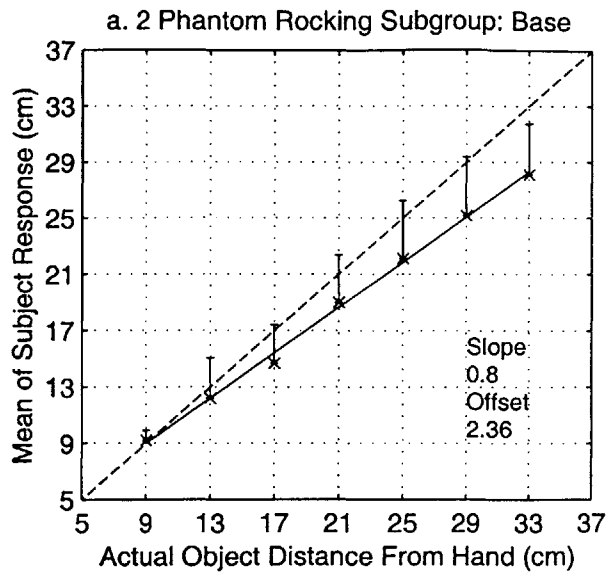
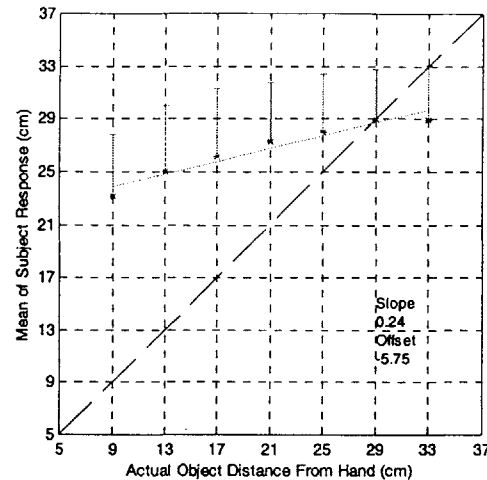

Figure 21: Mean Subject Response for Probing Style Subgroups in Experiment 3

**Experiment 4:** Virtual object (Tip force only; unrestricted probing)

Figure 22 shows the mean subject response for probing the virtual object with only force feedback at the tip of the stylus.



**Figure 22: Experiment 4: Mean Subject Response**

Perception was rather poor with subject perceiving, on the average, a .96 cm separation between adjacent object positions when, in fact, the distance between neighboring objects was 4 cm (indicated by the .24 slope). The high average standard deviation of 4.51 cm indicates that subjects were unable to consistently distinguish the stimulus from the neighboring object positions. The negative bias of 5.75 cm implies a fairly large average overestimation in distance perception.

**Experiment 5a:** Virtual object (Tip force only; probing restricted to rocking)

Figure 23 shows the plot of subject response versus actual object position for each stage of the training for Experiment 5a, in which subjects were presented only with tip force feedback and the style of exploration was limited to rocking the probe against the object.



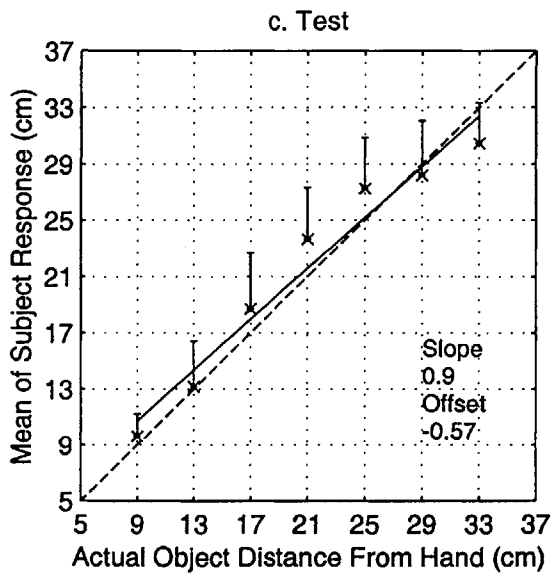
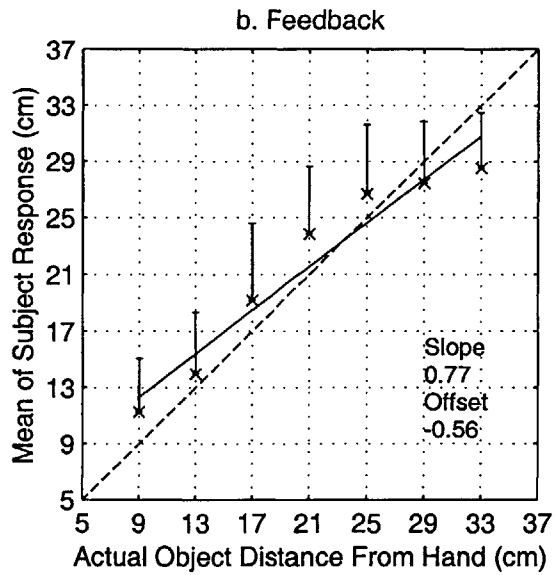
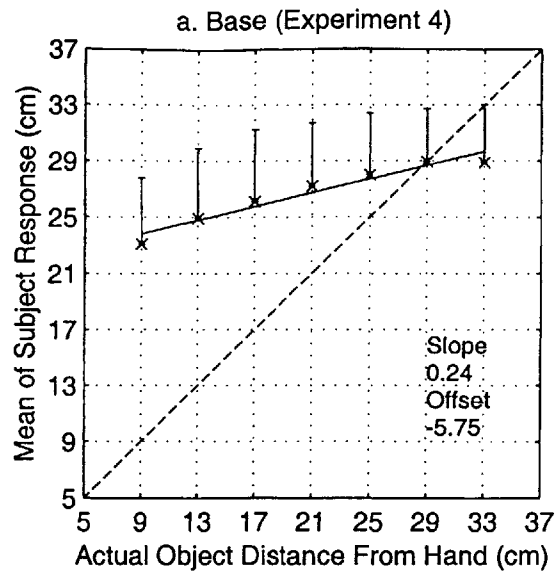

Figure 23: Experiment 5a (Tip Force Feedback, Rocking): Mean Subject Response

As in Experiments 2 and 3, subject performance improved relative to Experiment 4 after the correct-answer feedback session, in which slope and bias were .77 and -.56 cm, respectively. Average standard deviation did not change relative to Experiment 4, however. Perception improved again in the test phase with slope and average standard deviation of .90 and 3.26 cm, respectively. The bias remained the approximately the same, however, at -.57 cm. The presence of bias may be corrected with more training sessions, however, as indicated by the results of Experiment 2. The effects of training on slope, bias, and standard deviation can be seen in Figures 24, 25, and 26. Each follows a similar trend as for Experiments 2 and 3. The information transfer was calculated to be 1.01 bits for the test stage. These results demonstrate that under circumstances in which probe orientation is not restricted, true torque feedback is not required to haptically perceive object distance; ray-based rendering with only one 3 degree of freedom force-feedback device is sufficient.

**Experiment 5b:** Virtual object (Tip force only; probing restricted to tapping)

As in Experiments 4 and 5a, force-feedback was provided at the tip of the probe. However, in this experiment, probing was restricted to tapping. As a means of comparison, initial perception for this experiment was taken to be Experiment 4 as the force condition did not change. The plot is reproduced along with the feedback and test stages for this experiment in Figure 27 for more convenient comparison. Unlike in previous training experiments, the correct-answer feedback session did not result in significant improvements in subject perception. The slope was .35 and the bias was

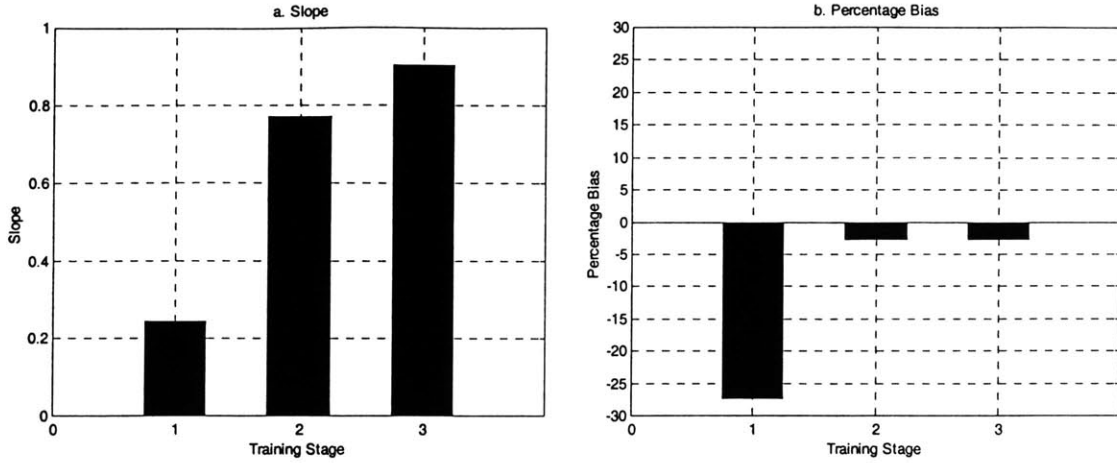

Figure 24: Effect of Training for Experiment 5a

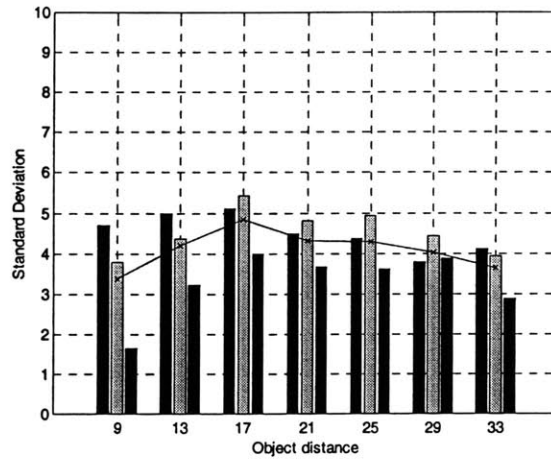

Figure 25: Standard Deviation grouped by training session for Experiment 5a

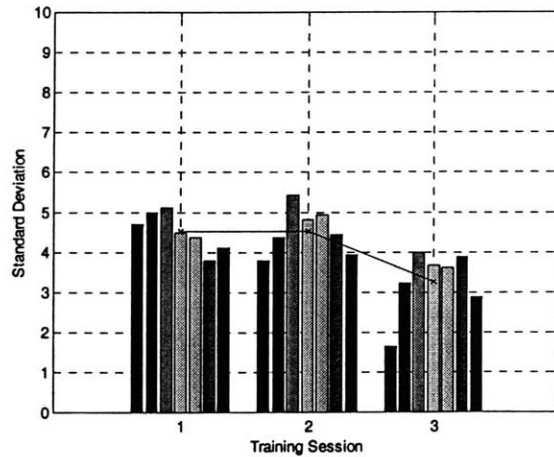

Figure 26: Standard Deviation grouped by object position for Experiment 5a

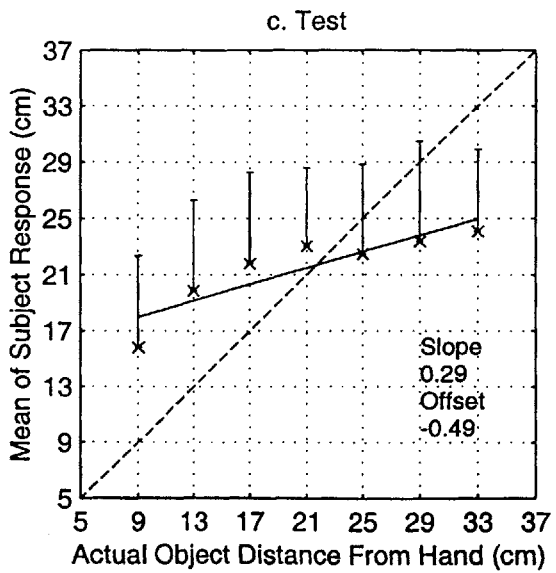
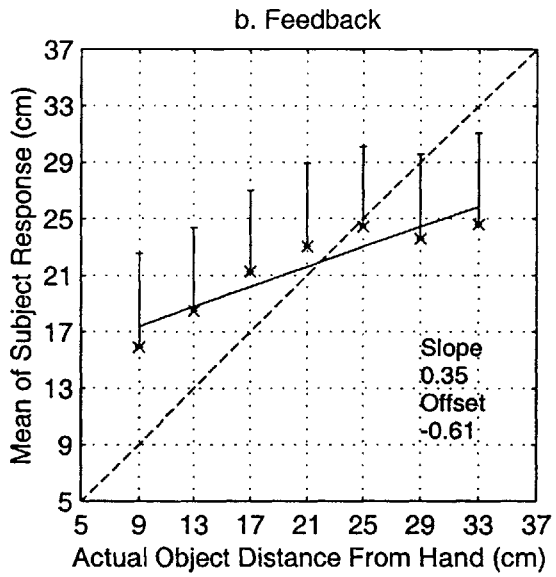
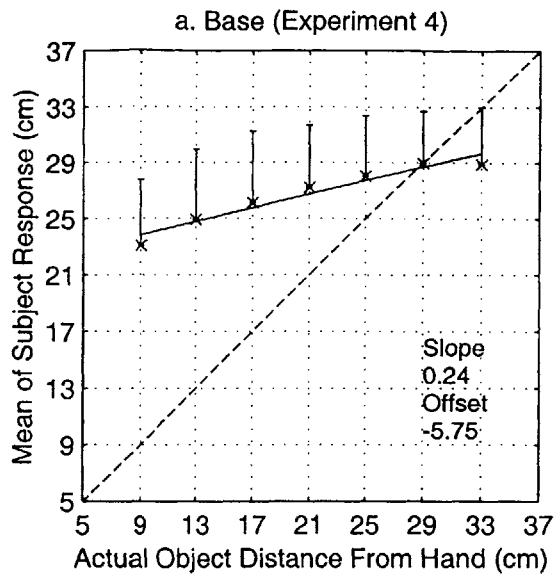
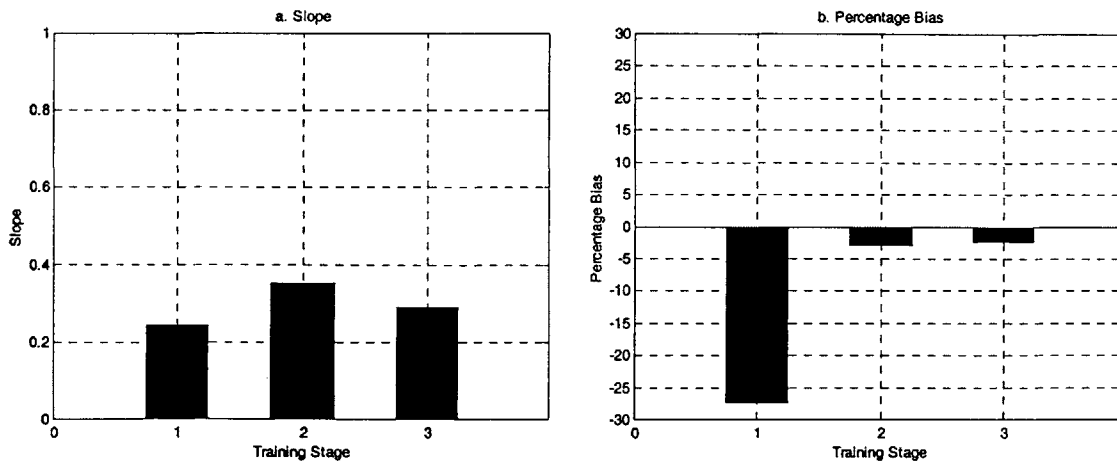

Figure 27: Experiment 5b (Tip Force Feedback, Tapping): Mean Subject Response

reduced to  $-0.61$  cm. On the average, responses were distributed by an even larger margin during this session than in the initial stage as indicated by the average standard deviation of  $6.05$  cm. The  $.35$  slope indicates that subjects still perceived the actual  $4$  cm separation of neighboring object positions to be only  $1.4$  cm. The slope and bias of  $.29$  and  $-0.48$  cm, respectively, for the test stage were comparable to the previous stage results. The average standard deviation was also approximately unchanged at  $6.33$  cm. The effects of training on subject ability to identify the absolute position of the object are seen in Figure 28.



**Figure 28: Effect of Training for Experiment 5b (Tip Force, Tapping)**

While the bias was largely corrected, the slope remained very poor. Figure 29 shows that, on the average, standard deviation did not vary a great deal as object distance increased. Figure 30 indicates that the scatter of subject responses increased with each training session. The information transfer was found to be  $.17$  bits. These results imply that when restricted to tapping, torque feedback is a necessary haptic cue since, in Experiment 3 (true force and torque feedback), subjects were able to accurately discern the different object positions when only tapping. The required haptic information to

judge the distance of the objects was not adequately presented when tapping with force-feedback only at the tip.

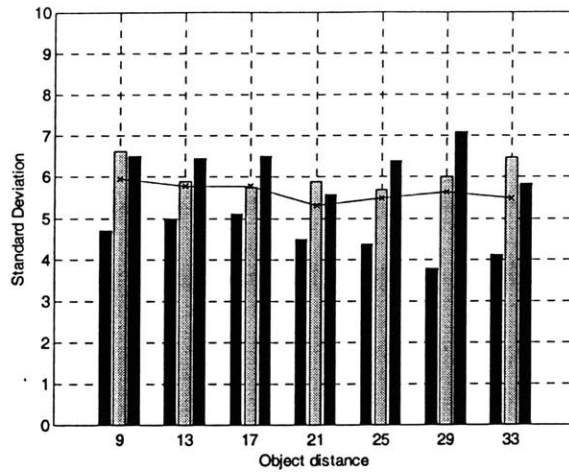

**Figure 29: Experiment 5b - Standard Deviation Grouped by Training Session**

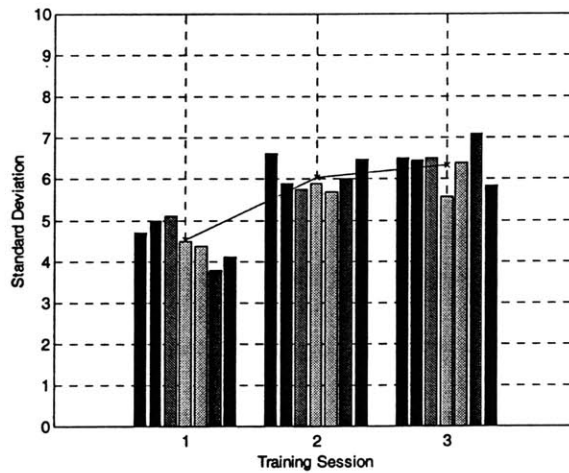

**Figure 30: Experiment 5b – Standard Deviation Grouped by Object Distances**

Note: Another subject employed a tapping method as well. However, he did not restrict the probe to a single orientation at the time of contact with the object. He intentionally tapped the object with the probe held at various angles. His performance was considerably better than that of the other subjects.

### 3.4 Comparison of Performance under different Experimental Conditions

The results of the test phase for each experiment is summarized in Table 1.

Table 1

Experiment	Slope	Average Standard Deviation	Bias (cm)	Information Transfer (bits)
1	.30	4.20	11.81	N/A
2	.90	3.23	-.03	1.05
3	.95	3.30	.09	1.16
5a	.90	3.26	-.57	1.01
5b	.29	6.33	-.48	.17

The conditions under which the subjects were asked to judge object distance in Experiment 1 (exploring the object by tapping such that the probe was horizontal at the moment of contact, and with no previous experience or correct-answer feedback) proved to be too impoverished as seen by the shallow slope and high bias. More significant conclusions are drawn from the subsequent experiments. The plots of subject response for the test stages in Experiments 2, 3, and 5 are collected in Figure 31. No substantial differences are seen when comparing plots for the real object, true force and torque, rocking under tip force conditions in Figures 31a, 31b, and 31c nor in the tabulated values for slope and bias. In each case, subjects were able to resolve the seven different stimuli into distinct distances, and perceived the 4 cm separation of neighboring objects to between 3.60 and 3.80 cm. The major discrepancy is seen in Experiment 5b, in which the slope was significantly lower than for the other conditions. These results may be more apparent in Figure 32a, which shows the slope of mean subject response as a function of experiment number (recall that the ideal slope is unity). The difference in slopes and average standard deviations for experiments 2, 3, and 5a are negligible when

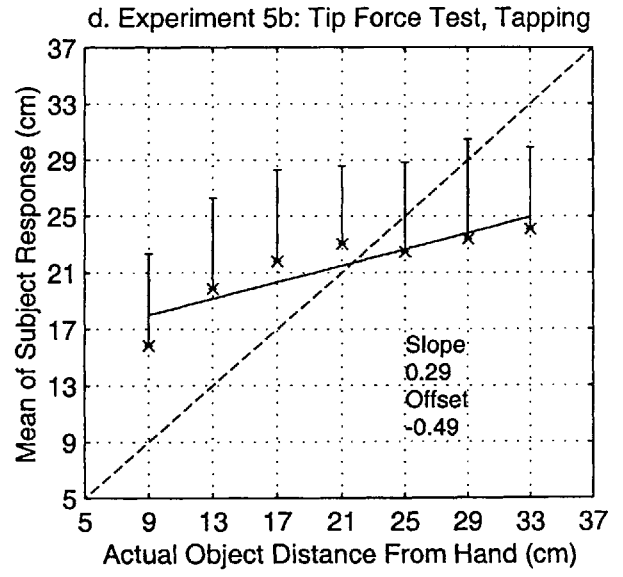
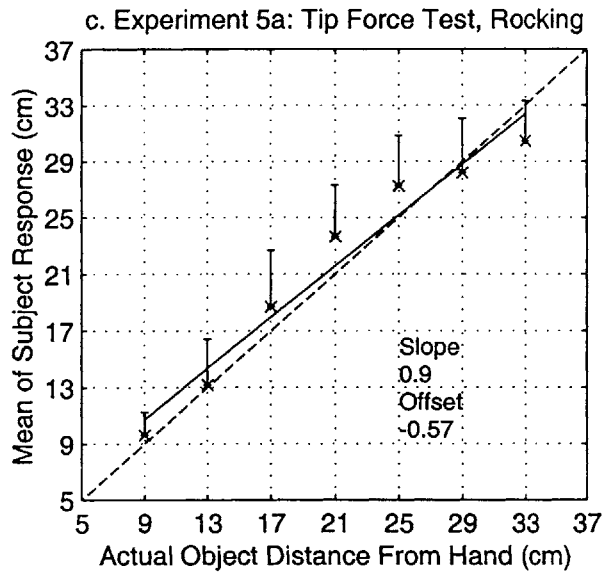
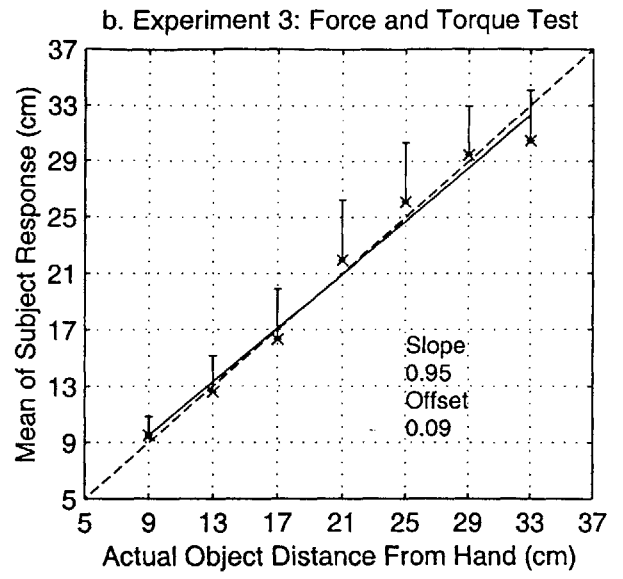
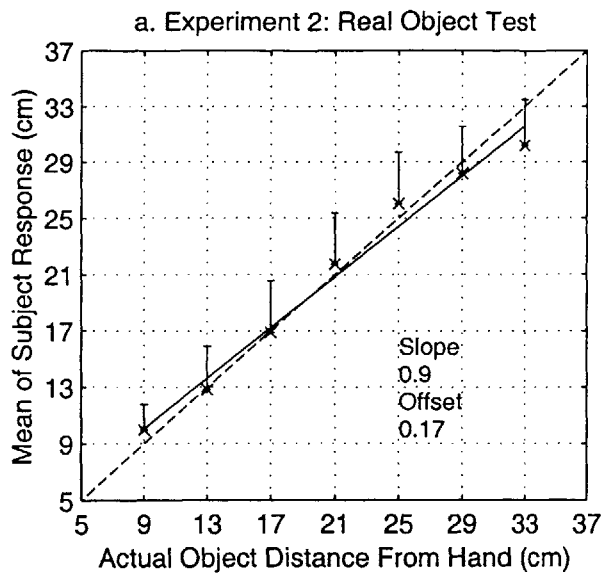

Figure 31: Test Sessions - Mean Subject Response



compared to those for Experiments 5b. Figure 32b shows subject bias as a function of experiment number (recall that ideal performance has zero bias). The biases for experiments 5a and 5b may seem large. However, these are absolute offsets from the ideal performance curve. If these values are normalized against the actual distance of the object, these biases are not as significant. For example, a .5 cm bias for an object located 21cm away is a 2.4% offset. The percentage bias as a function of experiment number is shown in Figure 32c. Though the biases for Experiments 5a and 5b are larger than those in Experiments 2 and 3, they are small relative to the average object distance (21 cm). Figure 33 shows how the standard deviation varied by object distance for each of the test experiments. For Experiments 2, 3, and 5a, a general trend is seen in which standard deviation levels off just under 4 cm. This indicates that, in general, with the mean response Experiments 2, 3, and 5a near the ideal response line, these standard deviations will not contain any of the discrete object positions other than the stimulus itself. Therefore, there is a high likelihood that the subject response will correspond to the correct object distance, with occasional errors in judgement resulting in responding with the immediate neighboring positions. For Experiment 5b, however, standard deviations are consistently greater than 6 cm. This means that the two object positions adjacent to the stimulus are each within one standard deviation of the mean response. Therefore, the subject response is most often distributed between these three object positions, with occasional responses in the adjacent object positions, which results in poorer performance. Figure 34 gives the standard deviation as a percentage of the distance of the actual object for each stimulus. This shows that following an early peak, there is a decrease in percentage standard deviation as object distance increases.

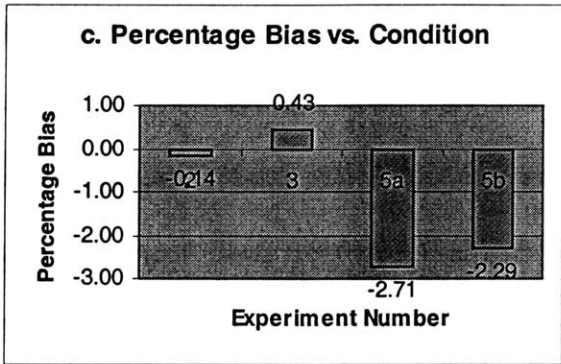
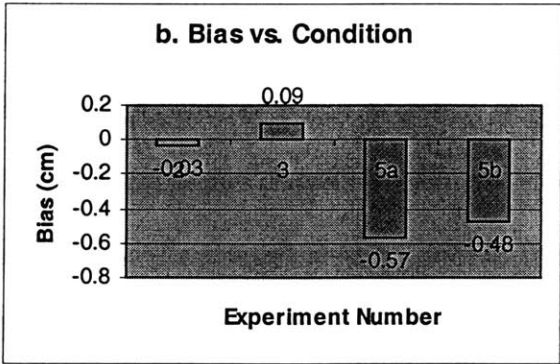
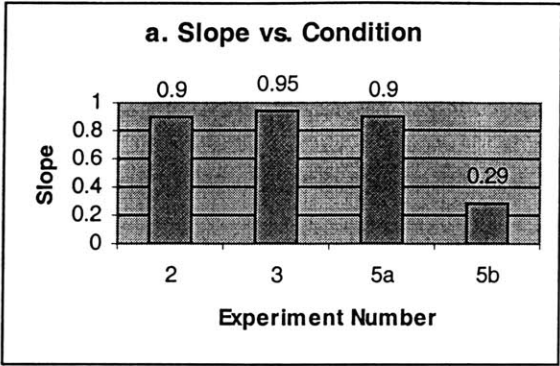

Figure 32: Performance under different force display conditions

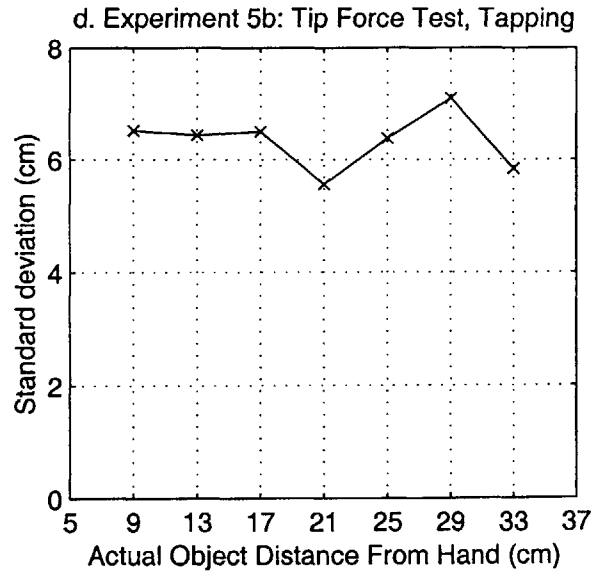
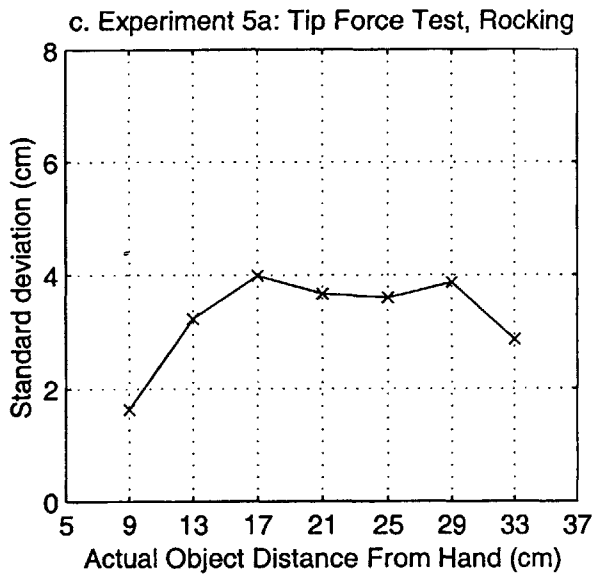
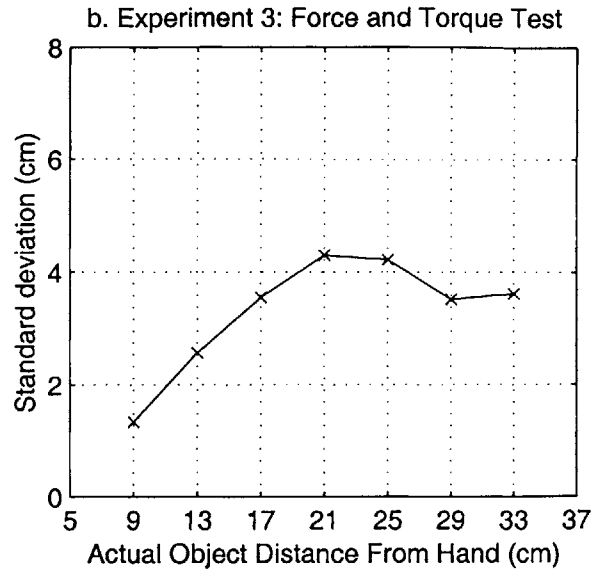
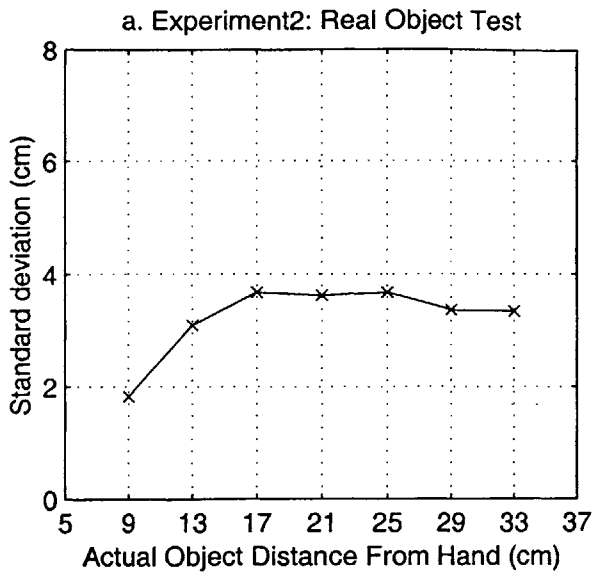

Figure 33: Standard Deviation under different force display conditions

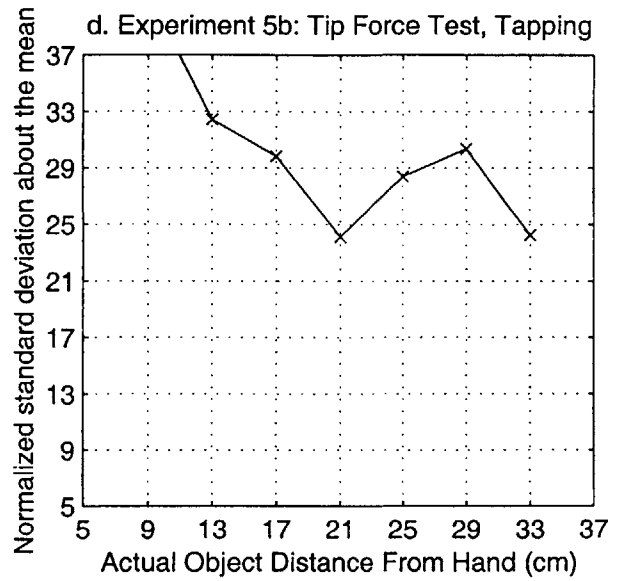
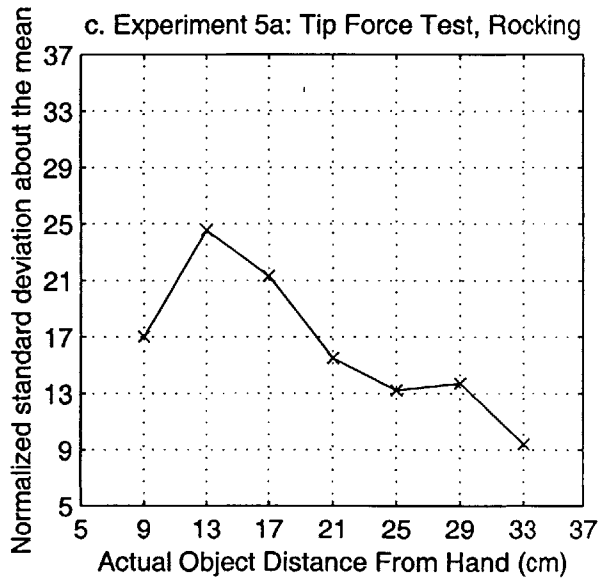
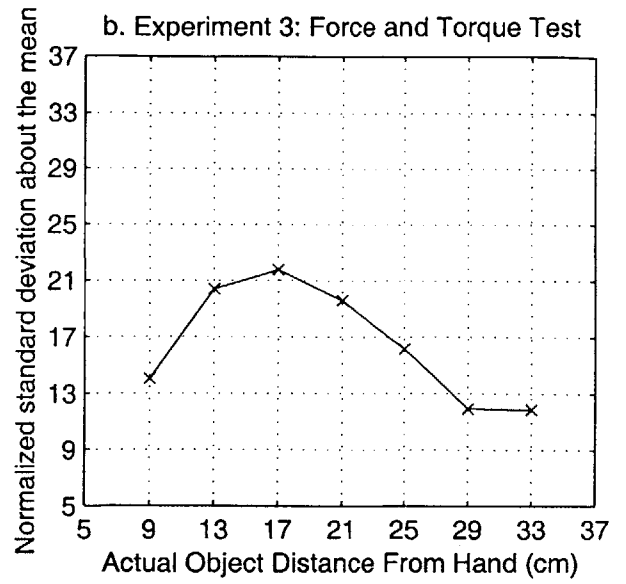
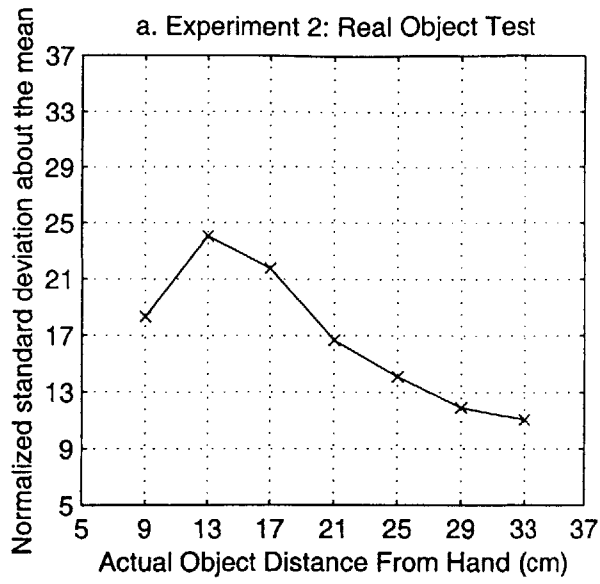
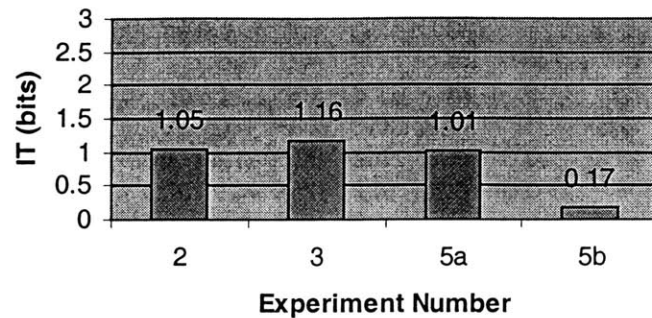

Figure 34: Normalized Standard Deviation under different force display conditions

		Response (cm)						
		33	29	25	21	17	13	9
Stimulus (cm)	33	54.4	28.6	11.0	4.7	0.6		0.6
	29	27.4	38.4	23.6	7.5	3.1		
	25	15.9	27.2	30.6	20.6	5.0		0.6
	21	0.3	11.6	25.2	37.1	21.4	3.8	0.6
	17	0.9	0.6	5.3	17.0	44.7	26.7	4.7
	13	0.6		0.9	2.8	10.0	60.0	25.6
	9			0.6		2.8	15.6	80.9

Figure 35: Experiment 2 Test Stage-- Confusion matrix in which the value in cell (i,j) is the frequency with which response  $R_j$  was given for stimulus  $S_i$ .

The maximum possible amount of information that can be transferred for the 7 object position experiments is 2.81 bits. This is determined from the total number of possible responses for a given stimulus. Due to the training sessions in which correct-answer feedback was provided following each trial, subjects were aware of the values of the seven distinct object positions. Therefore, for each stimulus, subjects knew the object to be at one of seven possible distances. The logarithm to the base two of the number of possibilities (seven) gives 2.81 bits, which gives the number of two-choice distinctions that have to be made in order to specify one particular response from the total of seven options. The amount of information transferred was calculated for each experiment and tabulated in Table 1. The probabilities used in calculating information transfer are taken from the confusion matrices constructed for each experimental condition. The probability confusion matrix for the test stage in Experiment 2 (real object) is shown in Figure 35 (the probability confusion matrices for all the other experiments can be found in the Appendix). As with the slope of the mean subject response line, the information transfer for each experiment shows no drastic change between experiments 2, 3, and 5a. However, there is a large reduction in information transmission in experiment 5b. These results agree with the conclusions drawn from the analysis, above. That is, considerably



**Figure 36: Information Transfer for each test stages**

less information was transmitted when subjects limited probe contact to a single orientation. Whereas the information transmitted with physical contact, provision of true force and torque feedback, and tip force feedback with freedom of multiple probe orientations is approximately equal, indicating comparable performance. Figure 36 shows IT as a function of experiment number. While subject performance in experiments 2, 3, and 5a is much better than in Experiment 5b, when compared to the maximum possible amount of information available, IT seems rather low. This is due to the fact that information transfer takes into account the entire spread of subject responses. These relatively low information transfers indicate that the mean of subject responses was quite accurate as shown by the majority of the responses lying on the diagonal of the confusion matrix (Figure 35). However, the actual responses were distributed about the mean, as indicated by the significant percentage of responses in the neighboring positions, which is why the information transferred was low compared to the maximum.

### **3.5 Measure of Resolution**

The just noticeable difference (JND) between two object positions describes the smallest distance separating the two objects such that each one can be distinguished on a

consistent basis, for example 70% correct discrimination may be used as the minimum requirement for consistent accurate perception. Typically, JND is computed from the results of pair-wise discrimination tests. While the results obtained in the previous chapter are taken from identification experiments, it is possible to compute a measure of haptic perceptual resolution of distance based on signal detection theory and a decision model for the one-interval, 2AFC (two alternative, forced choice) paradigm (Durlach, 1968). Due to the imprecision caused by attempting to measure perception of a continuous random variable (distance) with a finite number of discrete object positions, the values reported here are merely estimates of JND for the specific conditions examined. It is likely that these values can be taken as the upper bounds for JND. Perception of the different object positions is expected to be better for pair-wise discrimination experiments since the number of possible responses is reduced. In order to apply the decision model for a one-interval, 2AFC paradigm, each interval must be examined independently. Each of the 7 object positions can be viewed as a reference position with which the remaining 6 positions are compared. For this study, however, only neighboring object positions were analyzed. The sensitivity index ( $d'$  or  $d_{\text{prime}}$ ), measures the separation of the probability density functions for two stimuli (i.e.  $d_{\text{prime}}$  indicates how well the two different object positions could be distinguished). For this study,  $d_{\text{prime}}$  was estimated by the difference in the means for two neighboring object positions and divided by the average of the standard deviations. JND is defined as the distance between two stimuli at which  $d_{\text{prime}}$  has the value of 1. One way to visualize the meaning of this value is to imagine the two probability density functions are shifted farther apart (or closer together as the case may be) until the overlap between the two

gives a  $d'$  equal to 1. This corresponds to a 70% probability of responding correctly for a given stimulus. A  $d'$  of infinity corresponds to perfect resolution, while a  $d'$  of zero corresponds to random guessing, which gives 50% correct response. For  $d'$  to equal unity, JND must equal the average of the standard deviations of the two stimuli. The values for  $d'$  and JND are tabulated below for each of the 6 distance intervals for the test stages of the various experimental conditions.

Table 2:  $d'$

Force Display	Interval 1 (9cm – 13cm)	Interval 2 (13cm – 17cm)	Interval 3 (17cm – 21cm)	Interval 4 (21cm – 25cm)	Interval 5 (25cm – 29cm)	Interval 6 (29cm – 33cm)
Real Object	1.2	1.2	1.3	1.2	.6	.6
True Force and Torque	1.6	1.2	1.4	1.0	.9	.3
Tip Force: Rocking	1.5	1.5	1.3	1.0	.3	.7
Tip Force: Tapping	.7	.3	.2	.1	.1	.1

Table 3: JND (cm)

Force Display	Interval 1 (9cm – 13cm)	Interval 2 (13cm – 17cm)	Interval 3 (17cm – 21cm)	Interval 4 (21cm – 25cm)	Interval 5 (25cm – 29cm)	Interval 6 (29cm – 33cm)
Real Object	2.5	3.4	3.6	3.7	3.5	3.4
True Force and Torque	2.0	3.1	3.9	4.3	3.9	3.6
Tip Force: Rocking	2.4	3.6	3.8	3.6	3.7	3.4
Tip Force: Tapping	6.5	6.5	6.0	6.0	6.7	6.5

Table 3 shows that for all intervals for each of the experiments, excluding tapping under tip force-feedback only, the JND is less than the separation of the stimuli (4 cm). This agrees with the results presented in the previous chapter, which indicated that in each of these situations, subjects were able to accurately distinguish each object distance. The



last row, however, shows JNDs consistently greater than 6 cm. Since the separation between object positions was less than the JND, discrimination of two adjacent stimuli was beyond subject haptic perceptual ability. Another useful quantity to look at is percentage JND, which is found by normalizing JND with respect to the mean of the two object positions that define the corresponding interval (mean stimulus distance). %JND is tabulated below.

Table 4: % JND

Force Display	Interval 1 (9cm – 13cm)	Interval 2 (13cm – 17cm)	Interval 3 (17cm – 21cm)	Interval 4 (21cm – 25cm)	Interval 5 (25cm – 29cm)	Interval 6 (29cm – 33cm)
Real Object	21.6	22.8	18.9	15.3	13.0	11.5
True Force and Torque	17.7	21.2	20.5	17.7	13.9	11.9
Tip Force: Rocking	21.4	22.7	18.1	14.3	13.5	11.5
Tip Force: Tapping	36.3	31.1	26.9	26.2	29.4	27.3

In Figure 37 we see how %JND varies by mean stimulus distance relative to the hand. Weber’s Law states that percentage JND will remain constant and independent of variations in the reference stimuli (i.e. change in object distance in our case). For the real object, true force and torque feedback, and rocking under tip force conditions, we see that this is not the case. Instead, excluding the first stimulus interval distance, we have a fairly linear relation, in which the percentage JND is inversely related to the mean stimulus distance from the hand. If you recall Figure 33, above, in which the standard deviation was plotted against stimulus distance, the standard deviation settled at approximately 4 cm. Naturally, for increasing object distance, the ratio of this constant

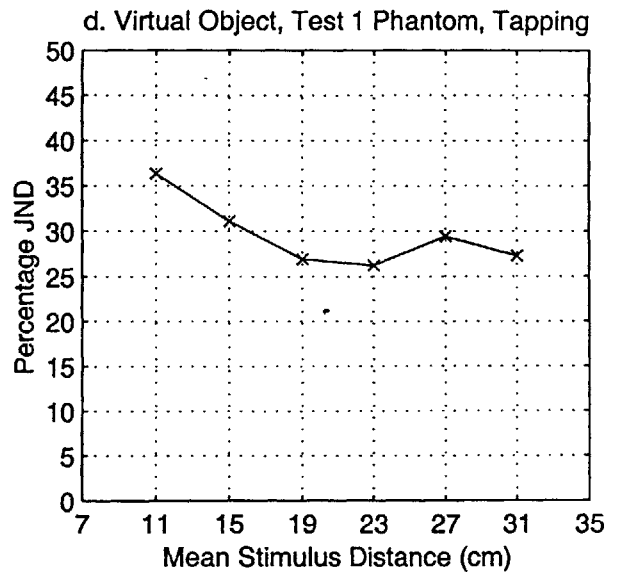
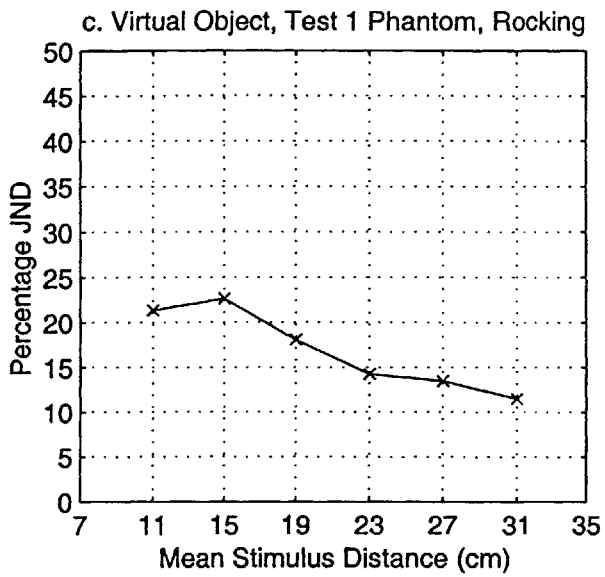
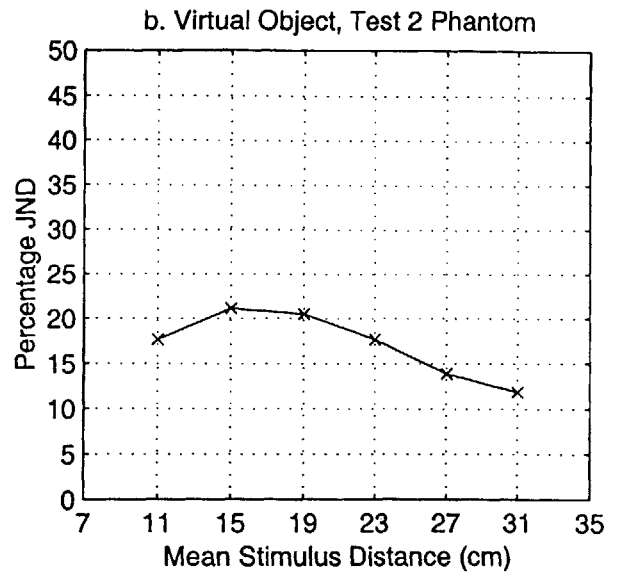
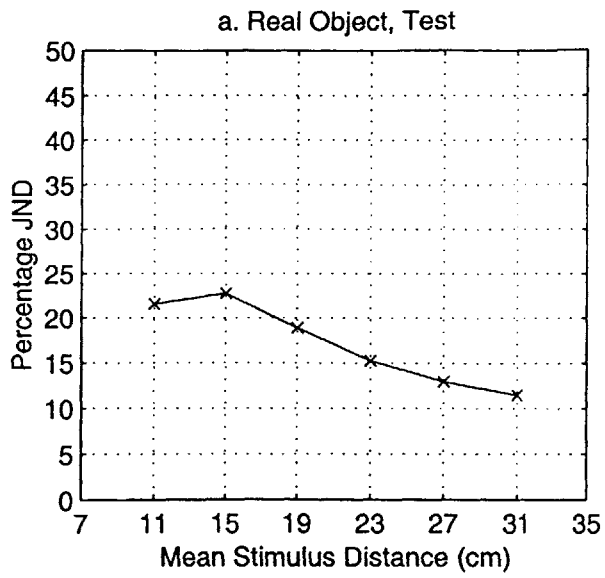

Figure 37: Percentage JND for different force display conditions

value to the stimulus distance will decrease. It is not a coincidence that the standard deviations in mean response approached the separation distance between adjacent objects. Knowledge of the seven discrete object distances, gained from the correct-answer feedback sessions, required subjects only to bin their judgements into one of seven categories rather than responding with any other distance in the continuous range of positions. Therefore, errors in perception will not result in slight variations in response, but correspond to immediate neighboring positions. For gross errors, the responses may not necessarily correspond to adjacent object positions to the actual stimulus but those farther away. This is likely the case for the tapping under tip force feedback condition. Initially, %JND is high (over 35%), and settles at approximately 27% for interval distances from 19 cm to 31 cm. Clearly, regardless of the distance of two stimuli from the hand, %JND is much higher for this experimental condition than in the others. This explains why subjects performed so poorly. In order for subjects to distinguish between two objects at different distances, the separation between the objects must be at least 25% of their mean distance from the hand, and even larger for object positions closer to the hand.

## **Chapter 4**

### **Discussion**

#### **4.1 Summary of Results**

From the results shown in the figures of Chapter 4, we see that perception of object distance when probing a real object after training was quite accurate as the subject response line was very close to the ideal performance line in terms of both slope and bias. This indicates that there is enough haptic information available in the act of probing a real object to distinguish various object positions, at least when the objects are 4 cm apart. Ray-based rendering techniques combined with the 5 DOF haptic interface provided both true force and torque feedback, producing an effective simulation of the haptic cues as demonstrated by the exceptional performance of subjects in Experiment 3. As the precision in perceiving object position with virtual objects proved to be almost the same as with real objects, Experiment 4 examined how much of the haptic information presented in Experiment 3 is actually required to make accurate judgments on object distance. Experiment 4 reduced the amount of haptic information presented to users by providing only force-feedback at the tip of the probe. Therefore, the magnitude of the torque felt at the hand was physically inaccurate. Even with this impoverished and misleading force display, subjects were able to accurately perceive the various object positions when exploration of the object was performed by rocking the probe against the object. True torque feedback proved to be unnecessary in this situation. This means that perception of object position through rocking was not based solely on force and torque information. However, when probing was limited to tapping against the object such that

the probe always struck the object with the same orientation, subject performance was quite poor. Thus, indicating that true torque feedback was needed during tapping. These last two results suggest that, in terms of perceiving object distance, orientation of the probe at the time of contact and the torque feedback provide redundant haptic information. One or the other is sufficient, with force-feedback and ray-based rendering, to determine the location of an object as shown in Experiments 3 and 4a. However, when the user is denied both true torque feedback and freedom of exploration, haptic perception of object distance is very poor, as shown in Experiment 4b. More in depth discussions concerning the possible methods by which subjects perceived object distance are presented below.

#### 4.2 Computational Theories

One might expect torque information to play a vital role in the haptic perception of object location. Indeed, examining the static force diagram of a probe in contact with an object (Figure 38), one can easily calculate the moment arm,  $d$ , if the reaction force,  $R$ , and the torque,  $T$ , are known.

$$d = T/R$$

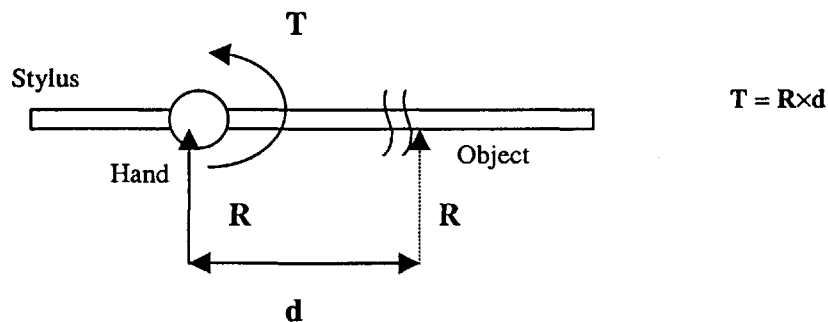
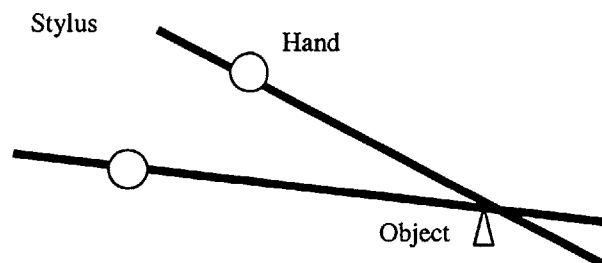

Figure 38: Static force model for determining object distance

But the distance of the object from the hand,  $d$ , is equal to the magnitude of the moment arm,  $|d|$ , since the moment arm is the distance over which  $\mathbf{R}$  acts to create a torque,  $\mathbf{T}$ . For this approach to finding  $d$ , knowledge of the value of  $|\mathbf{T}|$  is required. However, if subjects had used this method for determining object distance, they would not have been able to perceive the various object positions in Experiment 4a when the magnitude of the torque did not agree with the position of the object. Therefore, the method by which object distance is perceived is not dependent solely on force and torque feedback.

If we take a kinematic rather than kinetic approach to finding  $d$ , knowing torque is not necessary. Below is one such computational theory for determining  $d$  based on geometry by examining the intersection of two or more probe orientations at time of contact with the object (Figure 39).

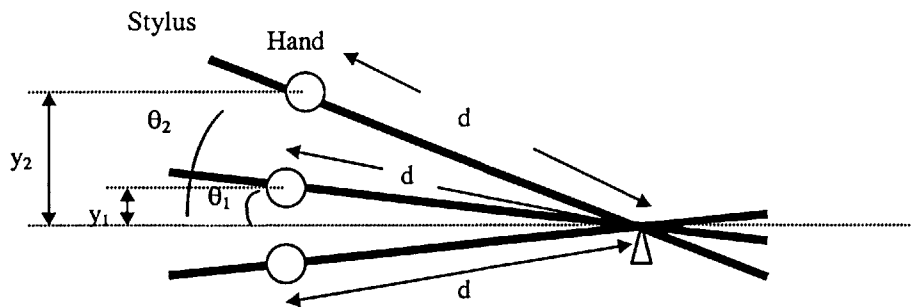

**Figure 39: Determining object distance based on intersection of two or more probe orientations**

However, since the rod and object are hidden from view of the subject, this approach is dependent upon the subject's haptic sense of probe orientation, which is possibly related to awareness of positioning of the arm and hand. The magnitude of the force felt at the moment of contact is not important. The force itself is only important in that it indicates contact has been made at that moment with the probe held in a particular orientation. If at the next moment of contact, the probe is in a different orientation, the position of the

object can be determined by locating the point at which the two probe orientations intersect.

A special case exists when using the object as a fulcrum and rocking the probe against it. This provides a continuous change in orientation for a fixed pivot point (Figure 40).



**Figure 40: Special case for determining object position based on geometry in which object is used as a fulcrum**

Therefore, all the orientations would intersect at the same point. One way to determine the mathematical expression for finding this intersection point is to examine the relationship between the angle of contact and the relative position of the hand. From simple geometry, it can be found that

$$d = (y_2 - y_1) / (\sin\theta_2 - \sin\theta_1),$$

where  $y_1$  and  $y_2$  are the vertical components, measured from a fixed reference height (in this case, the top of the object) at two different moments of contact and  $\theta_1$  and  $\theta_2$  are the corresponding angles of contact.

A second, but similar special case, requires knowledge of only a single orientation of the probe during contact with the object. The height of the object was constant throughout all trials and experiments, though subjects were not informed of this fact. If a subject

hypothesized that the height of all objects was the same, then a horizontal line could be projected on which the object must lie. By contacting the object with a single non-horizontal orientation of the probe, the location of the object can be determined from the intersection of the horizontal line with the orientation of the probe at the time of contact (Figure 41).

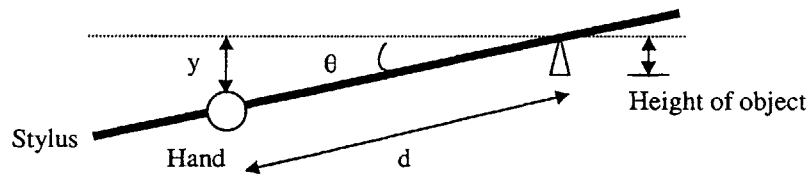

**Figure 41: Special case for determining object position based on geometry in which height of object is known**

The subject, then, needs to have a sense of the horizontal line and therefore, the height of the object, as well as the orientation of the probe. Geometrically, this is the same as the case presented above with one of the contact angles equal to zero. In this case, the mathematical expression is even simpler than the previous formula.

$$d = y/\sin\theta$$

Following Experiment 5b, several subjects commented that the height of the object seemed to be changing from trial to trial. So subjects may have been attempting to use this approach, but were unable to do so since they perceived the height of the object to be shifting between trials.

### 4.3 Hardware Requirements for Accurate Haptic Perception in VE

For any application in which the interaction of the entire stylus/tool with the environment is of interest, the collision detection algorithm must allow contact between objects and any point along the stylus, such as in the ray-based rendering technique. Determining the



hardware requirements for accurate haptic perception in virtual environments is not so straightforward. As one might expect, the necessary hardware will depend upon the application of the VE, however, force and torque requirements are not the only factors that should be considered. Taking into account the workspace of the application may lead to a reduction in the number and/or complexity of the haptic interfaces required for realistic haptic perception. In cases in which the user is free to move the stylus/tool through any motion and orientation, a single 3 DOF haptic interface is sufficient to present the haptic cues for locating the objects in the environment. This is because the information needed to locate the object can be obtained from the geometry of the situation. Torque feedback becomes a redundant cue provided that the user is permitted to change the orientation of the probe. Virtual sculpting is one such application. If the sculptor is to have the freedom to approach the piece from any direction, he must have the ability to manipulate a sculpting tool through a wide range of motions and orientations. This freedom, while possibly expensive in terms of manipulator workspace, eliminates the need for more than 3 DOF force feedback. If, however, there are constraints placed upon the motion of the stylus, such as in a laparoscopic surgical simulator, both force and torque feedback are needed to obtain a sense of the distances of the objects that come into contact with the instrument. In minimally invasive procedures, the motion and orientation of the instrument is restricted by the incision point through which it must pass. By removing the information obtained from varying the orientation of the tool, torque feedback becomes a necessary cue. Therefore, a 6 DOF haptic interface, or a parallel configuration of two 3 DOF devices as described above, is required.

It should be noted, however, that in the majority of virtual environments, haptics is not the only percept that is utilized. Some virtual environments will make use of sound, but in most cases, vision plays a large part in creating the virtual environment. Numerous studies have shown that combining modalities has an impact on one's overall perception (e.g. Wu, et al. 1999; Srinivasan, et al., 1996; Miner, et al., 1996). Therefore, while these results demonstrate the role of torque and in pure haptic environments, with the addition of other sensory information, the results would likely be considerably different.

## **Chapter 5**

### **Future Work**

#### **5.1 Additional Object Distance Discrimination**

To verify the theories presented in the Discussion section, above, additional perceptual experiments may include the following:

- Instruct subjects to probe object by tapping, but in more than one orientation.
- If it is true that the reflected force is significant only in that it indicates contact, then the magnitude of the force presented to the user should not affect perception.

Therefore, an experiment can be designed such that the force reflected by the haptic interface is not based on Hooke's Law, but rather a completely random function.

- In order to determine actual haptic resolution, conduct standard JND experiments in which subjects are presented with an object at a fixed reference distance and an object whose distance varies from trial to trial and asked to judge which one is closer.

#### **5.2 Extension to 6 DOF Experiments**

The current results are from a hardware setup that provided 5 DOF and varying the object distance in only a single direction. Varying object position in another direction(s) may lead to the mapping of a haptic perspective. More complex tasks such as object manipulation or placement rather than simple position determination may also be considered.

### **5.3 Multi-Modal Experiments**

Studies have shown that combining touch with another sensory modality increases the realism of the VE in comparison to either modality alone. While the majority of this work has been done through real world experiments (reviewed by Heller and Schiff, 1991), some studies concerning the perception of size and stiffness have been conducted in virtual environments (Wu et al., 1999, Cividanes, 2000?). Results from these studies indicate that human visual and haptic systems compensate for the perceptual biases that occur when either is used alone. Similar biases may affect one's perception of distances. Similar experiments to those discussed above can be repeated with the addition of graphics and/or sound to determine the difference between pure haptic perception of object distance with multi-modal perception.

## Appendix

- Individual subject results are presented here for the test stages of each of the experimental conditions.
- Probability confusion matrices for each experimental condition and all training stages over all subjects are presented here. The value in each cell of the matrix corresponds to the frequency with which the response  $R_j$  was given for stimulus  $S_i$ .

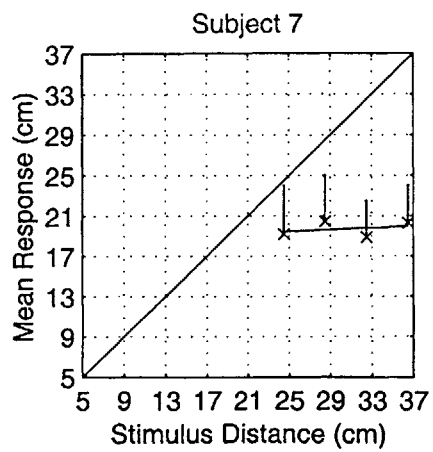
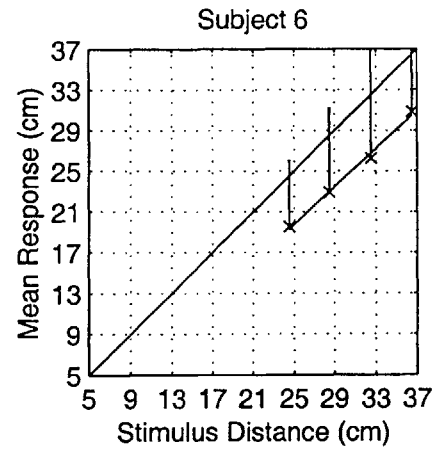
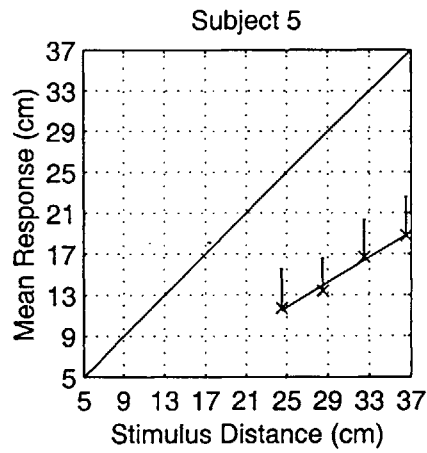
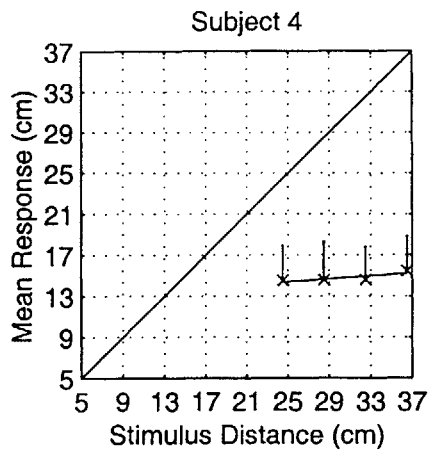
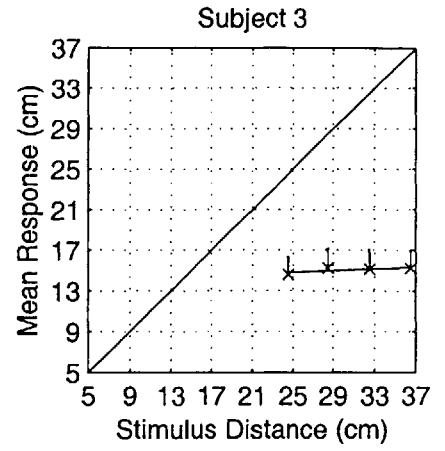
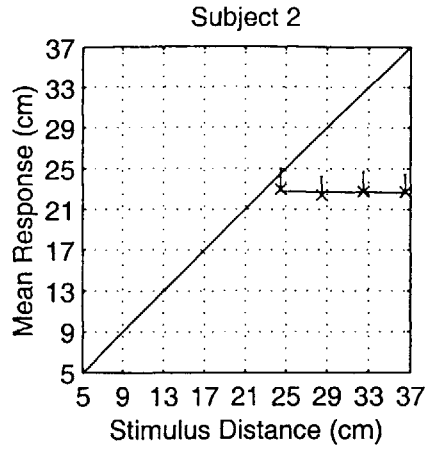
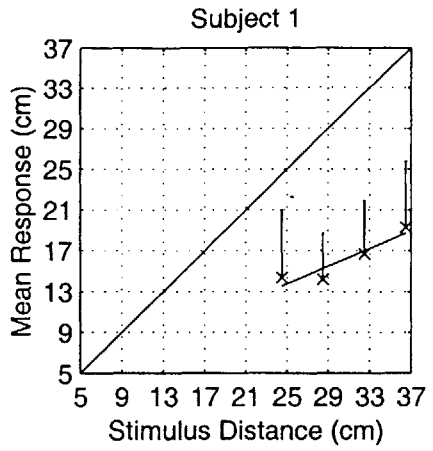

Figure A1: Experiment 1 (Real Object, Tapping), Individual Subject Response

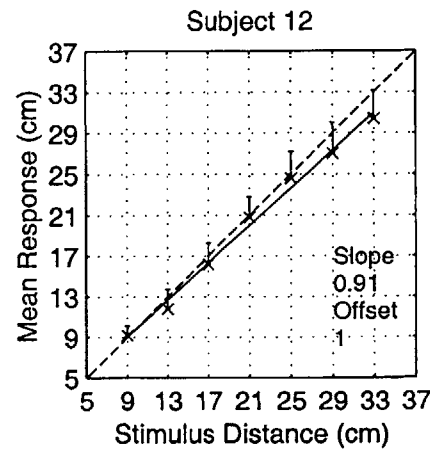
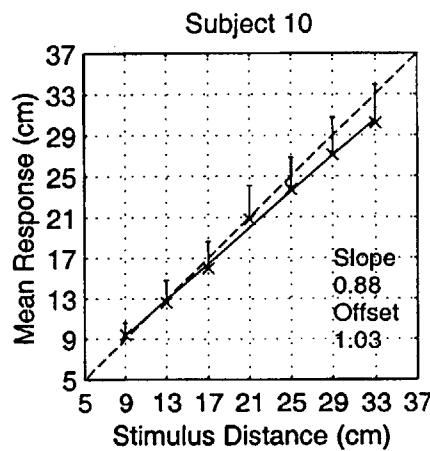
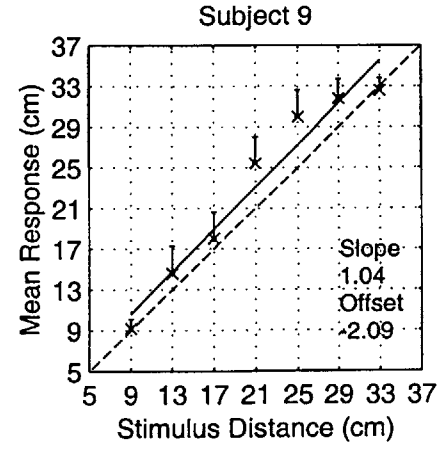
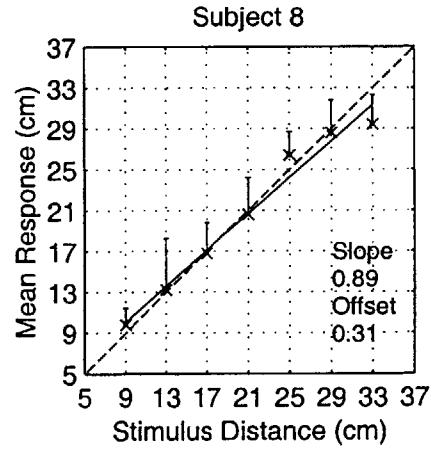
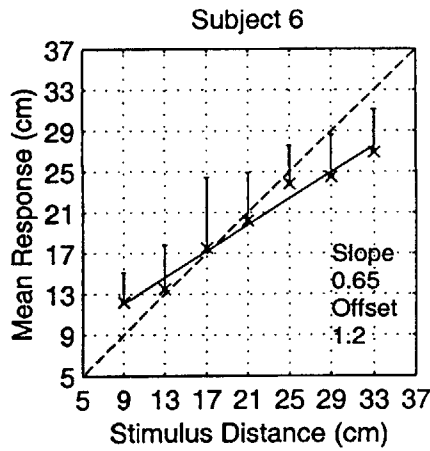
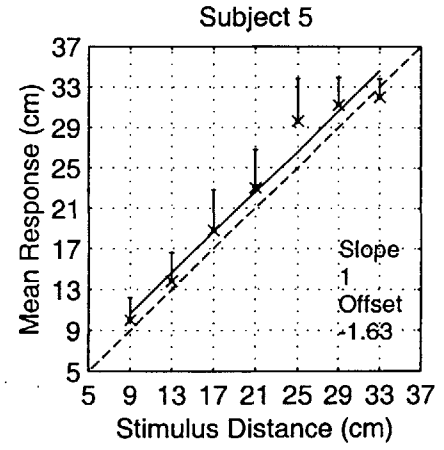
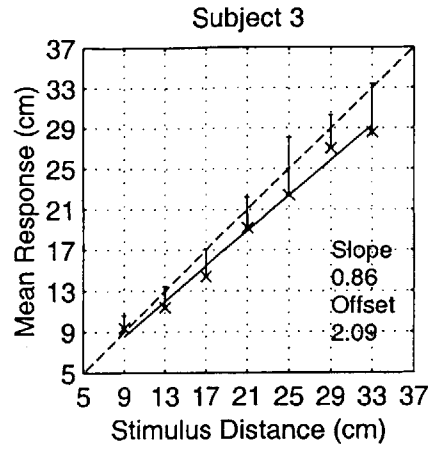
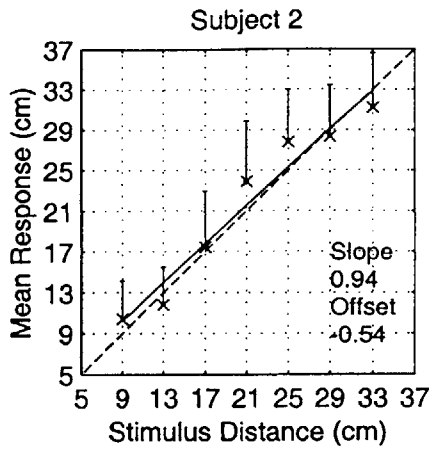

Figure A2: Experiment 2 (Real Object Test), Individual Subject Response

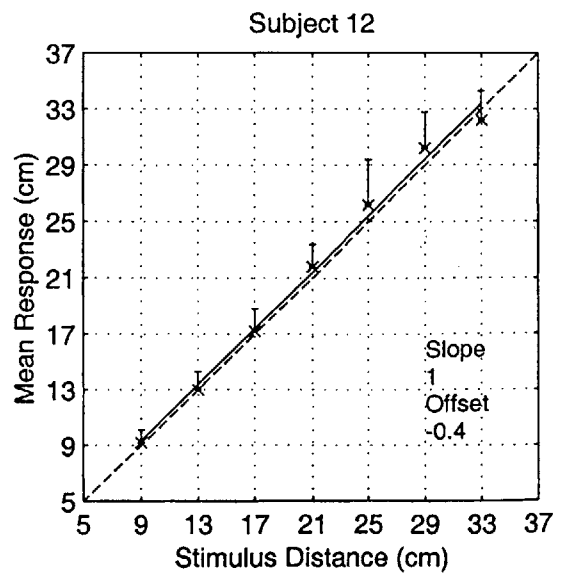
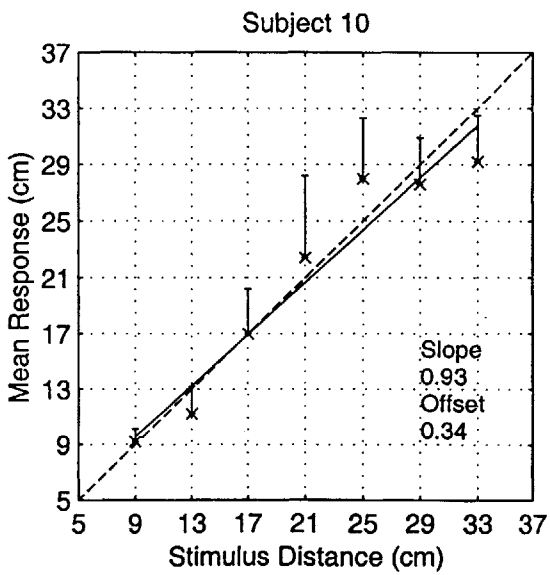
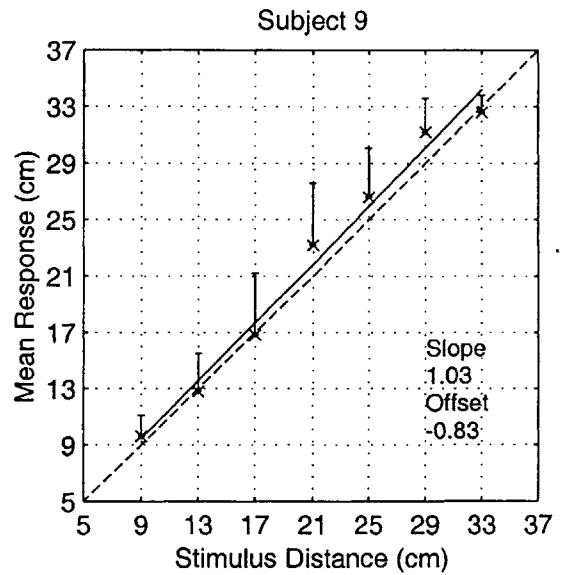
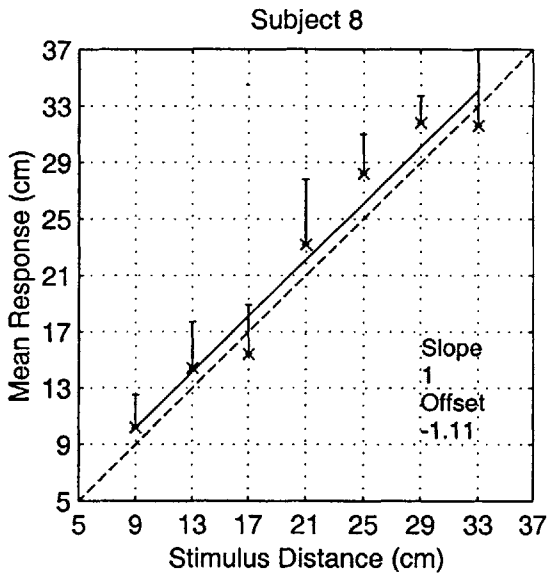
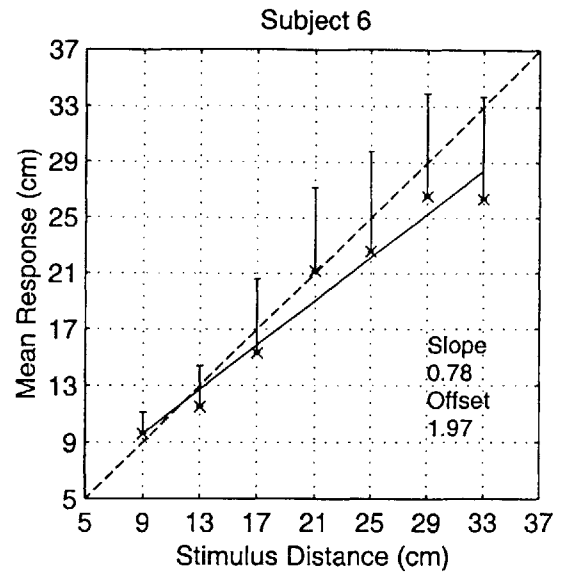
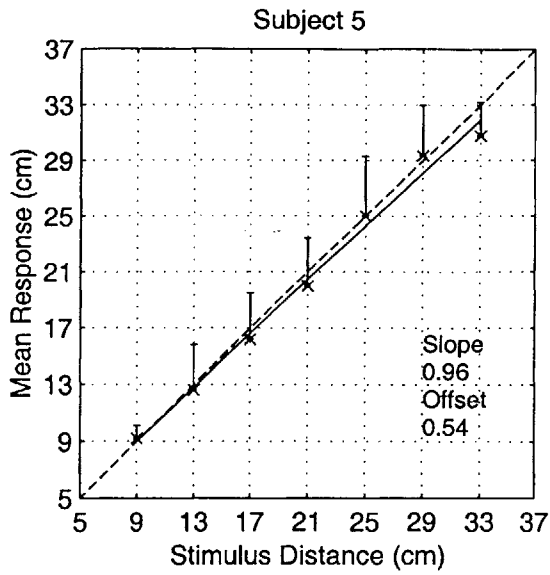

Figure A3: Experiment 3 (Force and Torque Test), Individual Subject Response



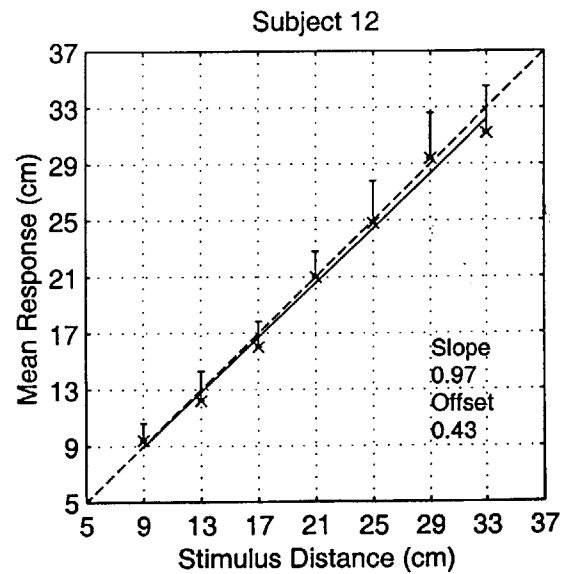
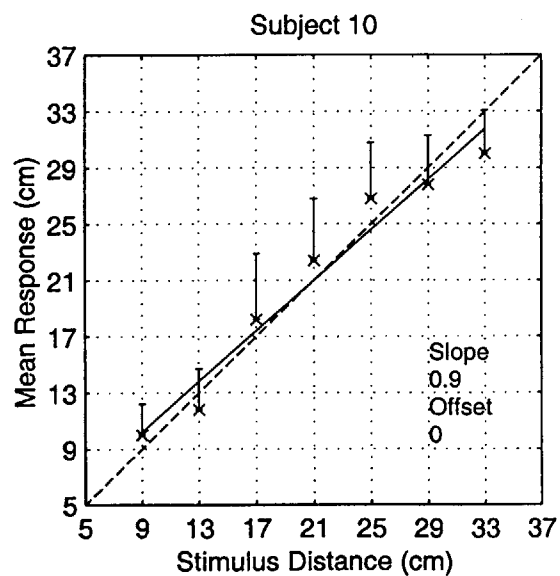
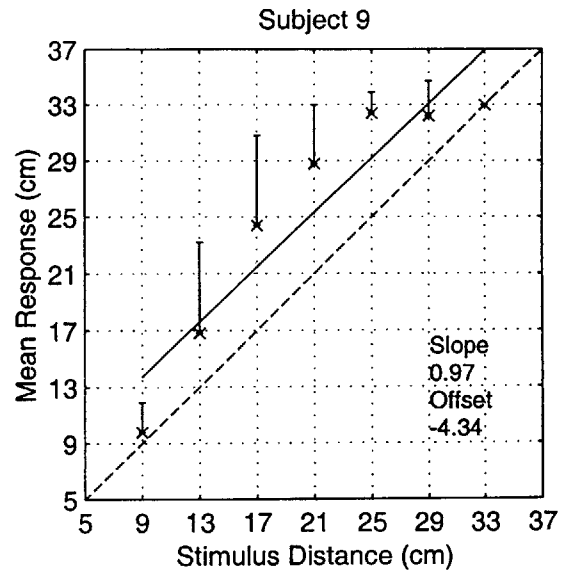
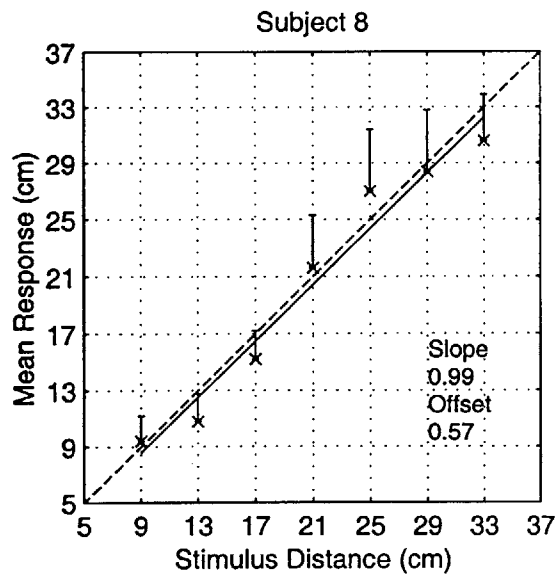
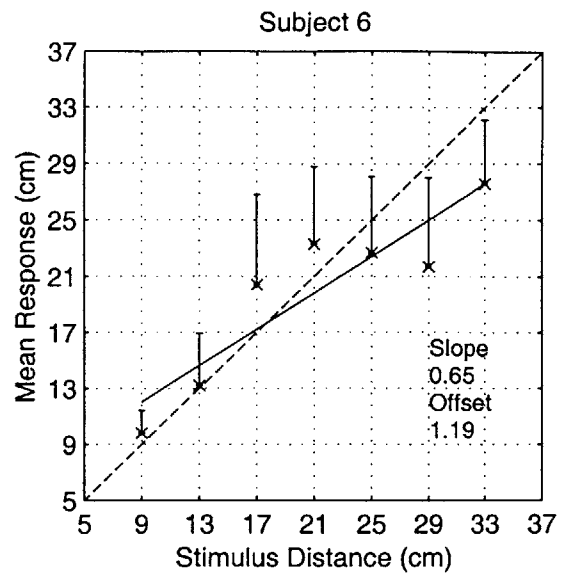
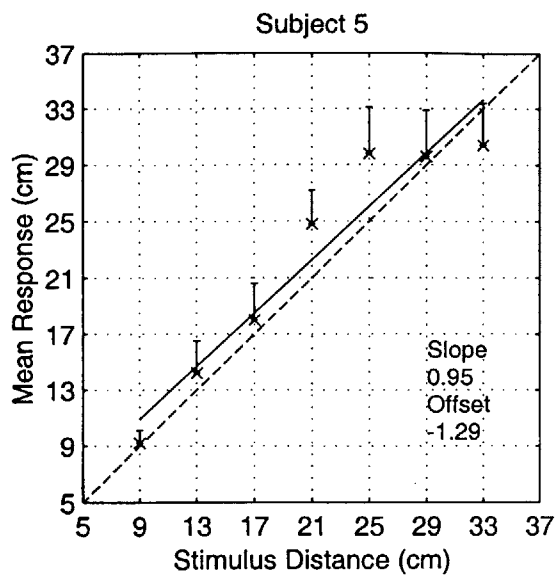

Figure A4: Experiment 5a (Tip Force Test, Rocking), Individual Subject Response

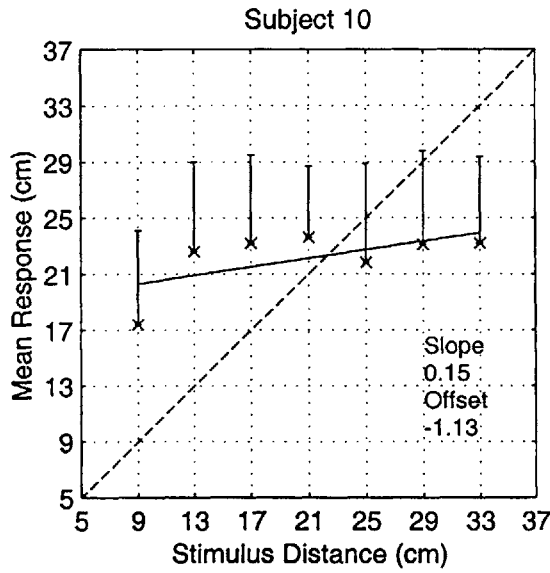
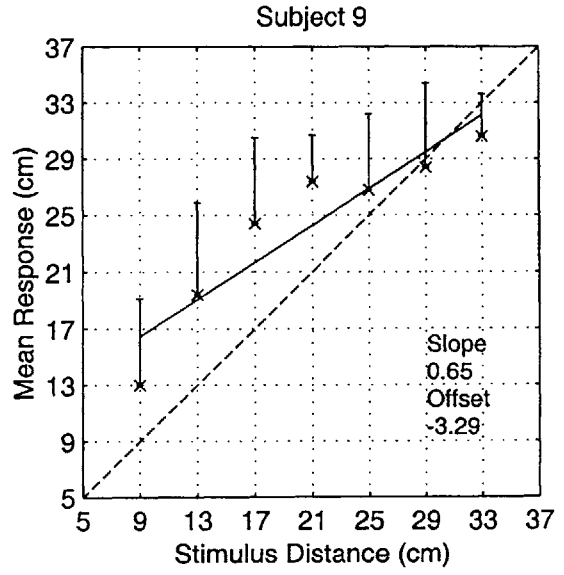
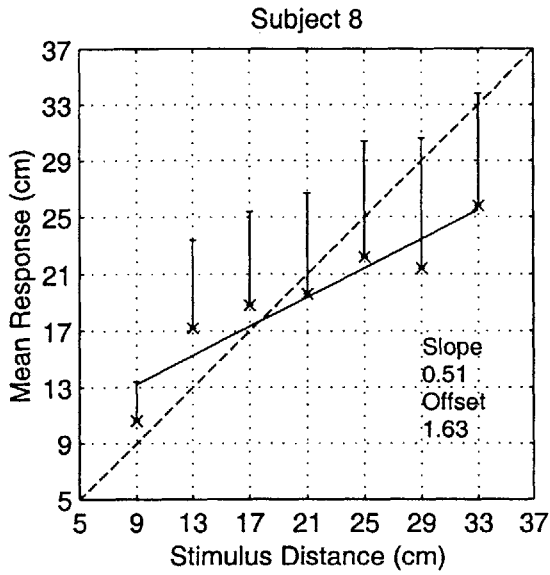
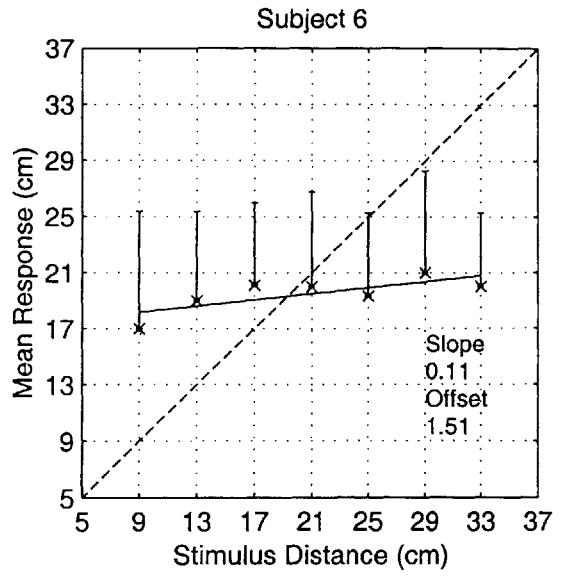
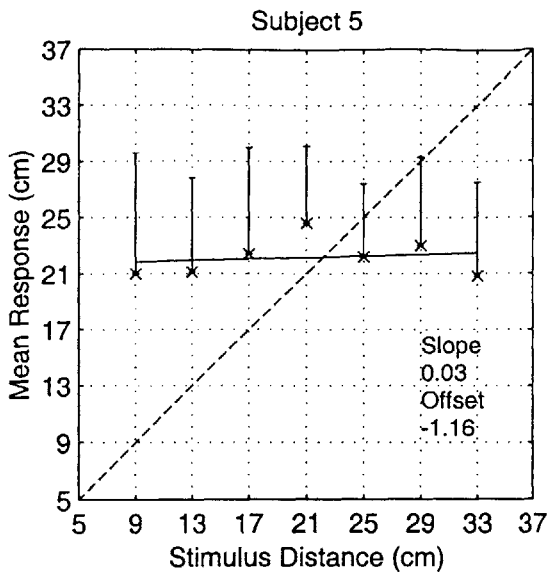

Figure A5: Experiment 5b (Tip Force Test, Tapping), Individual Subject Response

		Real Object: Feedback Session 1						
		Response (cm)						
		33	29	25	21	17	13	9
Stimulus (cm)	33	49.6	32.7	7.3	3.2	2.8	3.2	1.2
	29	28.8	33.6	20.8	10.0	2.0	3.2	1.6
	25	13.4	35.1	29.4	8.8	8.4	3.4	1.5
	21	2.8	15.4	22.0	22.0	18.5	17.7	1.6
	17	1.1	3.7	4.1	11.2	27.2	37.3	15.3
	13	1.4	1.4	0.7	3.9	17.6	34.9	40.1
	9				0.7	2.9	20.1	76.3
		Real Object: Feedback Session 2						
		Response (cm)						
		33	29	25	21	17	13	9
Stimulus (cm)	33	60.9	19.7	11.5	6.3	1.0		0.7
	29	32.6	36.5	22.3	6.5	1.6	0.6	
	25	16.4	28.3	28.9	18.9	4.4	1.9	1.3
	21	5.1	15.0	23.9	21.7	23.6	8.6	2.2
	17	0.6	3.1	3.8	12.2	42.5	32.2	5.6
	13		0.6	0.3	3.5	12.2	47.8	35.6
	9		0.6			2.9	14.7	81.7
		Real Object: Feedback Session 3						
		Response (cm)						
		33	29	25	21	17	13	9
Stimulus (cm)	33	63.6	28.2	7.0	0.0	1.3		
	29	30.1	34.8	24.4	7.6	1.9	0.6	0.6
	25	14.8	28.9	29.2	23.2	1.3	2.0	0.7
	21	3.8	14.8	26.4	25.2	20.4	8.2	1.3
	17		1.3	3.4	9.7	52.2	28.4	5.0
	13	0.6	0.3	0.9	0.9	10.4	52.5	34.3
	9				0.6	2.8	14.1	82.5
		Real Object: Feedback Session 4						
		Response (cm)						
		33	29	25	21	17	13	9
Stimulus (cm)	33	59.4	27.0	10.4	0.9	1.6	0.6	
	29	34.1	40.9	17.5	4.1	2.8	0.6	
	25	19.1	27.8	37.8	8.4	4.1	2.8	
	21	3.5	12.9	27.7	27.0	17.6	11.3	
	17	0.3	1.6	4.4	18.4	46.9	22.8	
	13				1.6	14.4	49.7	34.4
	9					1.6	16.6	81.9

Figure A6: Confusion Matrices for Experiment 2 (Real Object)

		Virtual Object: 2 Phantom, Base						
		Response (cm)						
		33	29	25	21	17	13	9
Stimulus (cm)	33	10.0	22.5	52.5	15.0			
	29	5.0	37.5	20.0	32.5	5.0		
	25	10.0	15.0	20.0	15.0	25.0	15.0	
	21	5.0	5.0	15.0	15.0	55.0		5.0
	17	5.0	2.5	7.5	5.0	30.0	45.0	5.0
	13			10.0	15.0	15.0	25.0	35.0
	9		5.0		5.0	5.0	25.0	60.0

		Virtual Object: 2 Phantom, Feedback						
		Response (cm)						
		33	29	25	21	17	13	9
Stimulus (cm)	33	57.9	27.9	10.0	1.7	1.3	1.3	
	29	37.1	31.7	18.8	7.9	3.3	1.3	
	25	10.4	31.3	36.7	12.9	5.8	2.9	
	21	1.7	4.6	20.4	32.1	30.0	7.9	3.3
	17	0.4	1.3	2.5	17.9	39.6	33.3	5.0
	13		0.4	0.4	5.0	16.3	47.1	30.8
	9			0.4	0.4	0.8	21.3	77.1

		Virtual Object: 2 Phantom, Test						
		Response (cm)						
		33	29	25	21	17	13	9
Stimulus (cm)	33	64.2	21.3	10.4		0.4	2.9	0.8
	29	42.9	37.9	13.3	2.5	0.4	2.9	
	25	10.8	38.8	29.6	12.9	4.6	2.5	0.8
	21	4.6	10.0	18.8	43.3	18.3	5.0	
	17	0.4	0.4	3.3	13.8	47.5	28.8	5.8
	13				1.3	16.3	53.3	29.2
	9					0.8	10.8	88.3

		Virtual Object: 1 Phantom, Base						
		Response (cm)						
		33	29	25	21	17	13	9
Stimulus (cm)	33	25.8	25.4	30.4	13.8	2.5	2.1	
	29	10.0	21.7	23.3	26.7	10.8	5.0	2.5
	25	2.1	9.2	21.7	27.1	19.2	18.3	2.5
	21	1.7	1.7	9.2	20.8	39.6	19.6	7.5
	17	1.3	0.4	0.8	7.5	19.2	47.5	23.3
	13	0.8			0.8	9.2	32.9	56.3
	9	0.8	0.8	0.8	0.8	1.3	12.1	83.3
		Virtual Object: 1 Phantom, Rocking, Feedback						
		Response (cm)						
		33	29	25	21	17	13	9
Stimulus (cm)	33	41.7	25.8	20.8	4.6	5.4	1.7	
	29	33.3	28.3	15.0	17.5	2.9	1.3	1.7
	25	22.9	32.1	25.4	10.4	5.0	1.7	2.5
	21	8.8	23.8	25.8	21.3	14.2	4.6	1.7
	17	5.8	7.5	6.7	20.0	37.5	20.0	2.5
	13	0.8	1.7	5.0	5.0	10.8	54.2	22.5
	9	0.8	2.5	0.8	2.1	4.2	21.3	68.3
		Virtual Object: 1 Phantom, Rocking, Test						
		Response (cm)						
		33	29	25	21	17	13	9
Stimulus (cm)	33	57.5	27.5	9.6	5.0	0.4		
	29	36.7	27.9	24.6	4.2	2.5	4.2	
	25	28.3	26.3	25.8	13.3	5.4	0.8	
	21	7.6	15.1	28.2	34.5	13.4	1.3	
	17	3.8	7.9	5.8	14.2	47.9	18.8	1.7
	13	0.8		2.1	5.4	11.3	52.1	28.3
	9					2.5	10.0	87.5

Figure A8: Confusion Matrices for Experiment 5a (Tip Force, Rocking)

Virtual Object: 1 Phantom, Tapping, Feedback  
Response (cm)

	33	29	25	21	17	13	9
33	17.5	29.0	20.5	10.0	10.0	8.0	5.0
29	17.0	21.0	22.5	12.0	11.0	9.5	7.0
25	19.5	19.5	21.5	17.0	12.0	10.5	0.0
21	10.0	19.5	27.5	14.0	15.5	10.5	3.0
17	9.5	11.0	14.0	27.5	24.0	8.0	6.0
13	4.0	12.0	6.0	26.5	11.5	26.0	14.0
9	2.0	11.0	7.0	13.5	5.5	26.0	35.0

Virtual Object: 1 Phantom, Tapping, Test  
Response (cm)

	33	29	25	21	17	13	9
33	20.0	21.0	18.0	16.0	12.0	8.0	5.0
29	18.5	20.0	18.5	14.0	11.5	9.5	8.0
25	10.0	23.0	13.5	21.5	16.0	11.0	5.0
21	7.0	25.5	22.5	18.5	14.5	7.0	5.0
17	10.5	16.0	13.5	25.0	17.5	12.5	5.0
13	3.1	11.7	21.4	21.4	15.3	14.8	12.2
9	5.1	6.1	13.3	4.6	14.3	15.8	40.8

## Bibliography

1. Armstrong, L. and Marks, L.E. (1999). Haptic perception of linear extent. *Perception and Psychophysics*, 61(6), 1211-1226.
2. Basdogan, C., Ho, C-H., and Srinivasan, M.A. (1997). A ray-based haptic rendering technique for displaying shape and texture of 3D objects in virtual environments, *Proceedings of the ASME Dynamic Systems and Control Division*, Ed. G. Rizzoni, DSC-Vol. 61, 77-84.
3. Beauregard, G.L. and Srinivasan, M.A. (1996). Sensorimotor interactions in the haptic perception of virtual objects, *Touch Lab Report 5*, RLE Technical Report No. 607, MIT.
4. Biggs, S.J. and Srinivasan, M.A. (In Press). Haptic interfaces, *The Virtual Environment Technology Handbook*, Ed: K. Stanney, Lawrence Erlbaum: New Jersey.
5. Carello, C., Fitzpatrick, P., and Turvey, M.T. (1992). Haptic probing: Perceiving the length of a probe and the distance of a surface probed. *Perception & Psychophysics*, 51, 580-598.
6. Chan, T-C. (1995). The effect of density and diameter on haptic perception of rod length. *Perception & Psychophysics*, 57, 778-786.
7. Chan, T-C. (1996). The situational effects on haptic perception of rod length. *Perception & Psychophysics*, 58, 1110-1123.
8. Chan, T-C. and Turvey, M.T. (1991). Perceiving the vertical distances of surfaces by means of a hand-held probe. *Journal of Experimental Psychology: Human Perception & Performance*, 17, 347-358.
9. Cividanes, A. (2000). Visual - haptic illusions in the perception of object compliance in virtual environments, B.S. Thesis, Department of Mechanical Engineering, Massachusetts Institute of Technology.
10. Durlach, N.I. (1968). A decision model for psychophysics. Unpublished manuscript, available at the Research Laboratory of Electronics, Massachusetts Institute of Technology.
11. Garner, W.R. and Hake, H.W. (1951) The amount of information in absolute judgements. *Psychological Review*, 58, 446-489.
12. Hancock, D. (1996). The sense of torque with a single phantom haptics device, *Proceedings of the First PHANToM User's Group Workshop*.
13. Ho, C-H., Basdogan, C., Srinivasan, M.A. (2000). Ray-based haptic rendering: Force and torque interactions between a line probe and 3D objects in virtual environments, *International Journal of Robotics Research*.
14. Ikei, Y., Wakamatsu, K., and Fukuda, S. (1997). Vibratory tactile display of image-based textures, *IEEE Computer Graphics and Applications*, November, 53-61.
15. Iwata, H. (1993). Pen-based haptic virtual environment, *Proceedings of IEEE Virtual Reality Annual International Symposium*, 55-5, 287-292.
16. Klatzky, R.L. and Lederman. S.J. (1999). Roughness perception with a rigid link interposed between skin and surface. *Perception and Psychophysics*, 61(4), 591-607.
17. Lederman, S.J. , Klatzky, R.L., Hamilton, C.L., and Ramsay, G.I. (1999). Perceiving roughness via a rigid probe: Psychophysical effects of exploration speed and mode of

- touch. *Haptics-e The Electronic Journal of Haptic Research*, 1(1). Available at: <http://www.haptics-e.org>.
18. Massie, T.H. and Salisbury, J.K. (1994). The phantom haptic interface: A device for probing virtual objects. *Proceedings of the ASME Dynamics Systems and Control Division*, number 55-1 in ASME, 295-301.
  19. Miner, N., Gillespie, B., and Caudell, T. (1996). Examining the influence of audio and visual stimuli on a haptic display. *IMAGE Conference Proceedings*.
  20. Salisbury, J.K., Brock, D., Massie, T.H., Swarup, N., and Zilles, C.B. (1995). Haptic rendering: Programming touch interaction with virtual objects. *ACM Symposium on Interactive 3D Graphics*.
  21. Srinivasan, M.A. (1995). Haptic interfaces, *Virtual Reality: Scientific and Technical Challenges*, Eds: N. I. Durlach and A. S. Mavor, Report of the Committee on Virtual Reality Research and Development, National Research Council, National Academy Press, 161-187.
  22. Srinivasan, M.A., Beauregard G.L., and Brock, D.L. (1996). The impact of visual information on the haptic perception of stiffness in virtual environments. *Proceedings of the ASME Dynamics Systems and Control Division*, number 58 in ASME, 555-559.
  23. Wernecke, J. (1994). *The Inventor Mentor*, Addison Wesley.
  24. Wong, T-S. (1977). Dynamic properties of radial and tangential movements as determinants of the haptic horizontal-vertical illusion with an 'L' figure. *Journal of Experimental Psychology: Human Perception and Performance*, 3(1), 151-164.
  25. Wu, W-C. (1999). Visual - haptic interactions in multimodal virtual environments, M.S. Thesis, Department of Mechanical Engineering, Massachusetts Institute of Technology.
  26. Wu, W-C., Basdogan, C., and Srinivasan, M.A. (1999). Visual, haptic, and bimodal perception of size and stiffness in virtual environments. *Proceedings of the ASME Dynamic Systems and Control Division*, Ed. N. Olgac, DSC-Vol. 67, 19-26.