

ROOT AND STRUCTURE-PRESERVING TRANSFORMATIONS

by

JOSEPH E. EMONDS

M.A., University of Kansas

(1964)

SUBMITTED IN PARTIAL FULFILLMENT  
OF THE REQUIREMENTS FOR THE  
DEGREE OF DOCTOR OF  
PHILOSOPHY

at the

MASSACHUSETTS INSTITUTE OF  
TECHNOLOGY

August, 1970

Signature of Author . . . . .  
Department of Foreign Languages and Linguistics  
March 3, 1970

Certified by . . . . .  
Thesis Supervisor

Accepted by . . . . .  
Chairman, Departmental Committee  
on Graduate Students



## ROOT AND STRUCTURE-PRESERVING TRANSFORMATIONS

by

Joseph E. Emonds

Submitted to the Department of Foreign Literatures  
and Linguistics on March 3, 1970, in partial fulfillment  
of the requirements for the degree of Doctor of Philosophy.

## ABSTRACT

In this study, I have been motivated by essentially the same problem as was Ross in his doctoral dissertation (Ross, 1967): that of imposing constraints on grammatical transformations. Like Ross, I start from the premise that various conditions and restrictions on when various transformations may apply are not *ad hoc* specifications which are part of the individual rules, but are rather reflections of some deeper grammatical principles which define the formal framework in which transformational rules operate. The constraints proposed in Ross's dissertation (for example the co-ordinate structure constraint or the complex NP constraint, but the others as well) essentially specify that constituents cannot be moved out of certain structural configurations, even though these configurations otherwise satisfy the structural description of a transformation which would move these constituents.

This study is an attempt to define the conditions when the structural changes of transformations can actually apply, just in the way that Ross tried to define the conditions when the structural descriptions of transformations are actually applicable (more correctly, "satisfied"). That is, my constraints essentially specify that constituents cannot be moved into certain structural configurations.

From a study of English transformations, I have arrived at the following tentative hypothesis, subject of course to testing and refinement and perhaps rejection on the basis of other languages. Constituents are to be divided into "phrase nodes" (NP, S, VP, PP, AP) and "non-phrase nodes." Various ways in which the class of phrase nodes may be formally characterizable are mentioned in appropriate places in the text, but in any case, they can be listed as a set of substantive universals in linguistic theory. A phrase node X in a tree T can be moved, copied, or inserted into a new position in T, according to the structural change of a transformation whose structural description T satisfies, only if at least one of two conditions is satisfied: (i) In its new position in T, X is immediately dominated by the highest S or by any S in turn immediately dominated by the highest S. (A transformation having such an effect is a "root transformation.") (ii) The new position of X is a position in which a phrase structure rule, motivated independently of the transformation in question, can generate the category X. (A transformation having such an effect is a "structure-preserving transformation.")

Non-phrase nodes may also be moved, copied, or inserted by either a root or a structure-preserving transformation, but they may also be moved by a third type of transformation: a single, specified non-phrase node may be moved over a single specified adjacent node (but not over more than one such node or over a variable). This is a "minor movement rule." (Further restrictions are placed on this type of rule in Chapter IV.)

It is interesting to note at the outset that such important transformations as wh fronting, dative movement, there insertion, adjective-over-noun movement, complex NP shift, and (verbal) affix movement\* (among many others, depending on the analysis used) are counter-examples to this claim in their usual formulations. Such transformations will be discussed in the text in the appropriate place.

---

\* Affix movement becomes a counter-example when one realizes that verbal affixes must move over pre-verbal adverbs as well as verbs.

## ACKNOWLEDGEMENTS

Many thanks are owed to all my teachers and fellow students at M.I.T. and elsewhere who discussed this material with me, but most of all I have benefited from the close readings and careful criticisms of Noam Chomsky, Morris Halle, John Ross, and Michael Brame. I also owe much to extended discussions with Ray Jackendoff, John Bowers, Frederick Newmeyer, Ken Hale, Adrian Akmajian, and many others.

I would like to thank Katrina Streiff for preparing the final copy, and to apologize at the same time (though words without deeds mean little) for utilizing the unfair divisions of labor of our academic world which inevitably heap the boring work of typing on women who have better things to do.

## TABLE OF CONTENTS

CHAPTER I: ROOT TRANSFORMATIONS	1
I.1 Preliminaries	1
I.2 The Phrase Structure Rule for Expanding S	4
I.3 Subject-Auxiliary Inversion	5
I.4 Verb Placement in German	10
I.5 Tag Questions	12
I.6 Adverb Preposing	14
I.6.1 Negated Constituent Preposing	14
I.6.2 Directional Adverb Preposing	15
I.7 Parenthetical Clauses	17
I.7.1 Another Use of Subject-Simple Verb Inversion	17
I.7.2 Quote Preposing	19
I.7.3 Non-Factive Parentheticals	21
I.8 Some Other Preposing Rules	24
I.8.1 Topicalization	24
I.8.2 VP Preposing	24
I.9 Right and Left Dislocation	25
I.10 Preposing around <u>Be</u>	27
Conclusion to Chapter I	32
CHAPTER II: STRUCTURE-PRESERVING NP MOVEMENT TRANSFORMATIONS	33
II.1 The Passive Construction	34
II.1.1 The Active-Passive Relation in English	34
II.1.2 The Structure-Preserving Property	37
II.1.3 The Passive Rules in the Structure-Preserving Framework	39
II.1.4 The Optionality of the <u>By</u> Phrase in the Passive	43
II.2 <u>There</u> Insertion	47
II.2.1 <u>There</u> Insertion as Structure-Preserving	47
II.2.2 The Status of the Auxiliary <u>Be</u>	55
II.3 Dative Movement Rules	62
II.4 <u>It</u> Replacement	67
II.5 Conjunct Movement	72
II.6 The Possessive Transformation	73
II.6.1 The Phrase Structure Rule for Expanding NP	73
II.6.2 A Comparison of NP Preposing and the Possessive Transformation	78
II.7 Obligatorily Reflexive Verbs	84
II.8 <u>There</u> Replacement	88
Conclusion to Chapter II	89

CHAPTER III: THE STATUS OF EXTRAPOSITION	91
III.1 Arguments that Sentences and Infinitives Are not NP's	93
III.1.1 Two Exceptional Classes of Gerunds	93
III.1.2 The Deep Structure of Sentence and Infinitive Complements	95
III.1.3 The Position of Object Complements	97
III.1.4 Sentences and Infinitives in Other Non-Subject NP Positions	99
III.1.5 Sentences and Infinitives in Subject Position	103
III.1.6 Other Arguments Confirming the Non-NP Status of Infinitives and Sentences	110
III.2 An Alternative to Rosenbaum's Explanations	119
III.2.1 Rosenbaum's Noun Phrase Complements	119
III.2.2 Rosenbaum's Verb Phrase Complements	125
Conclusion to Chapter III	133
CHAPTER IV: EXTENDING THE STRUCTURE-PRESERVING CONSTRAINT	134
IV.1 Adjective Phrase Movement Rules	134
IV.1.1 Adjective Movement	134
IV.1.2 Adverbial Adjective Phrases	144
IV.2 Structure-Preserving Rules Which Move S Nodes	163
IV.2.1 Cleft Sentences	163
IV.2.2 Extraposition from Noun Phrase	172
IV.2.3 Complement Extraposition	174
IV.3 The Node PP and its Distribution	180
IV.4 Wh Fronting as a Structure-Preserving Rule	190
IV.5 Complex NP Shift	204
CHAPTER V: MOVEMENTS OF NON PHRASE NODES	206
V.1 Structure-Preserving Movements of Pre-Terminal Symbols	208
V.1.1 NEG Transportation	208
V.1.2 Affix Movement	211
V.1.3 AUX Movement	218
V.1.4 Some Considerations on Clitic Placement in French and Spanish	226
V.2 Minor Movements of Pre-Terminal Symbols	234
V.2.1 DEG Postposing	234
V.2.2 DET Incorporation	235
V.2.3 Particle Movement	236
V.2.4 Article Movement	237
V.2.5 Verb Clitic Inversion in Spanish	238
V.2.6 Quantifier Postposition	238
V.2.7 Further Restrictions on Minor Movement Rules	242
Bibliography	244

## CHAPTER I: ROOT TRANSFORMATIONS

This study is an attempt to restrict the notion of "grammatical transformation" in a generative grammar. In particular, I will claim that those synchronic, syntactic rules that have until now been included in the rather general class of transformations are in fact members of one of three much more restricted classes of grammatical rules. These three kinds of rules will be called "root transformations," "structure-preserving transformations," and "minor movement rules."

The definitions of these classes and the arguments for their existence will require discussion of many syntactic processes. An adequate formulation will entail making revisions and innovations in the accepted forms of a transformational generative grammar, so it is well to begin by reviewing those grammatical notions that provide a relatively fixed basis of the discussion.

I.1 Preliminaries I assume familiarity with many of the notions of transformational grammar; in particular, with those underlined in this section. A generative grammar consists of semantic, phonological, and syntactic components. Part of the syntactic component is a set of phrase structure rules. A phrase structure rule consists of a symbol A on its left-hand side and a sequence of symbols B . . . C on its right-hand side.

These rules define a set of formal objects called phrase-markers, which can be diagrammatically represented as trees. In exposition, I will ignore this distinction, referring to phrase-markers as trees. A partial tree can be constructed (graphically) from a phrase structure

rule R by writing its left-hand symbol A over its right-hand symbols B . . . C, and connecting A to each of B, . . . , C by lines. A is then said to be expanded as B . . . C by R. A full tree is then constructed by expanding in turn each of B, . . . , C according to the phrase structure rules, and subsequently expanding the results of this until pre-terminal symbols are reached. Pre-terminal symbols are defined as those which do not appear on the left-hand side of phrase structure rules. To complete the tree, a terminal element, chosen from the lexicon, is placed under each pre-terminal element. The terminal elements are lexical entries of semantic, phonological, and syntactic features; we will use capitals to represent all symbols in phrase structure rules and all features, but we will abbreviate entire lexical entries by using, as closely as possible, English orthography (underlined). The lexicon and the phrase structure rules together comprise the base.

The trees defined or generated by the base are called deep structures. They are subject to a linearly ordered series of mappings called transformations, each of which maps input trees which satisfy its structural description into output trees according to the instructions in the transformation's structural change. The trees which result from applying in order to the deep structures all the transformations whose structural descriptions are satisfied are the surface structures. These are the input to the phonological component. It has previously been held that the deep structures were the input to the semantic component, but some recent work, especially that of Chomsky (forthcoming) and Jackendoff (1969), indicates that this input may consist of pairs of a deep and a surface structure (DS,SS), where SS is the surface structure that results from applying all the transformations to DS.



The branch points in the trees are nodes, whose labels are given by the phrase structure rules. Node A (immediately) dominates node B if it appears (immediately) over B in the path from B to the highest node in the tree, called the root of the tree. A string of lexical entries (morphemes) which is dominated by a node labeled A (more briefly, dominated by A) when A dominates no other lexical entries, is a constituent of type A; i.e., it is an A.

If the reader is not familiar with the terms underlined above, he should consult discussions of them in Chomsky (1965) and Chomsky (1957).

Although the aim of this paper is to define three restricted classes of transformational rules, possible membership in these classes will be seen to depend on the phrase structure rules and not on the notation used to write the transformations. Since the empirical content of my claims will rest on the precision and adequacy of the phrase structure rules, much of the discussion will center on them.

If my claims prove to be correct, it may be that the transformational notation devised by Chomsky in earlier work should be revised in order to reflect the restrictions on transformations imposed by these claims. In fact, different notations may be appropriate for the three classes of rules. These questions have not been approached in this study; suffice it to say that, at least for expository purposes, the transformational notation of Chomsky (1961) has been adequate.

I assume familiarity not only with the notion "phrase structure rule," but also with the particular phrase structure rules that have been proposed for English, as, for example, those given in the second and third chapters of Chomsky (1965). But none of these will in the end be adopted without some revision. All the rules that will be used

will be introduced explicitly in the first discussion that directly concerns them.

A few other preliminary notions may be useful. The nodes N, V, A, M, and P will be referred to as lexical nodes. (N = noun, V = verb, A = adjective, M = modal verb, and P = preposition.) The nodes NP, VP, AP, S, and PP will be called phrase nodes. A relation holds between lexical nodes and phrase nodes: each phrase node can immediately dominate at most one lexical node. A lexical node dominated by a phrase node is said to be the head of that phrase node. Furthermore, NP's may have only N heads, and similarly for VP and V, AP and A, S and M, and PP and P. (But I do not claim that a phrase node must have a head.) The class of phrase nodes may be characterizable as the only nodes under which an unlimited amount of recursion is <sup>ever</sup> permitted in surface structure, but I have not investigated this possibility in detail.

The above restrictions do not rule out the possibility of phrase structure rules which expand phrase nodes as a sequence of non-lexical nodes. Nor do they exclude lexical (or other) nodes from dominating phrase nodes; however, a restriction on recursion under non-phrase nodes would limit this latter phenomenon.

In attempting to define and delimit the classes of root and structure-preserving transformations, I will confine myself to studying the grammatical processes of English, unless another language is explicitly mentioned. The permanent linguistic value of the notions to be introduced, of course, cannot be established until they are tested and refined through a study of other languages.

I.2 The Phrase Structure Rule for Expanding S The root of a tree, as mentioned earlier, is the highest node. In English, and probably

universally, the root must be S. We need now to write the phrase structure rule for expanding S, since this rule plays an important part in defining root transformations. In writing this rule, I exclude from the constituent "verb phrase" (VP) certain elements which do not occur in English in the clauses traditionally termed "non-finite"; i.e., in infinitives, participles, and gerunds.\* These elements include present and past tense verb endings (TENSE) and modal auxiliaries. Thus, I take the underlined phrases in (1) to be VP's.

- (1)        John continued counting his money.  
             To have been chosen for this post is a great honor.  
             He helped by being cheerful at the right moment.

Formal justification for using the symbol VP in this way will be given in Chapter V. The resulting S expansion rule is (2):

- (2)        S → COMP - NP - TENSE - (M) - VP

COMP is the morpheme that, and perhaps than and as. M is will, can, may, etc. Subject pronouns occur only in NP's immediately dominated by S. TENSE in (2) can be either the morpheme s/∅ (the present tense ending) when it (TENSE) occurs with the syntactic feature -PAST, or the morpheme ed (the past tense ending) when it occurs with +PAST.

I.3 Subject-Auxiliary Inversion    Rather than set down immediately a definition of root transformation, I will approach this central idea gradually, through the rules which it covers. In this way, needed modifications of accepted terms can be made more plausible, and apparent

---

\*POSS-ING and FOR-TO complements in the terminology of Rosenbaum (1967).

counter-examples can be eliminated before hand.

We will consider first the subject-auxiliary inversion which occurs in direct questions, except when the subject itself is questioned. By auxiliary in this study I will always mean just those verbal elements which undergo this rule: modals, have (in certain uses), be, and do. Whether or not this term, used here for convenience, corresponds to some syntactic feature or node AUX will be discussed in later sections and chapters. This inversion is also used in certain exclamations, wishes, and sentences with preposed negative constituents.

- (3)        Wasn't that brave of him!  
              Isn't it cold out!  
              May you always be as thoughtful as she was!  
              Never in my life have I spoken to him.

The mechanics of this transformation are well-known; if the subject of the highest S is preceded by a questioned (wh) or a negated constituent, the order of the subject and the following auxiliary, which includes a TENSE affix and a possible n't are reversed. According to Katz and Postal (1964), there is an underlying preposed questioned constituent whether even in yes-no questions, which causes auxiliary inversion like other wh constituents. This whether appears explicitly in embedded questions.

- (4)        John wonders whether Mary is coming.  
              The question of whether they will support us is still undecided.

I will show in Chapter V that the first post-subject auxiliary (including do, have, and be) is always in the M position when subject-auxiliary inversion applies. I will assume that the rule essentially changes (5a) into (5b), where X is a node that dominates wh or NEG.

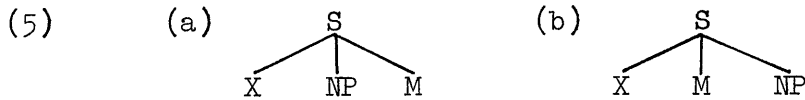

The important characteristic of this inversion rule for our purposes is that it applies only in the highest S; it doesn't apply in relative clauses and indirect questions:

- (6) We talked about how we would escape.  
 She doesn't know why they weren't co-operative.  
 The papers which you burned were important.

"Highest S," however, does not describe exactly the contexts for subject-auxiliary inversion, since this rule also applies in conjoined sentences immediately dominated by the highest S:

- (7) She didn't do the dishes, and why should she?  
 I know it was expensive, but never in my life have I been  
 so thrilled.  
 When is he coming, and where is he from?  
 Come in right now, or do I have to use force?

(The conditions under which such mixed sentence types can be conjoined are not known with precision, but this is of no consequence here.)

Sometimes the conjoined sentence exhibiting inversion is only an abbreviated (tag) form of a full sentence. Thus, "neither-auxiliary-NP" is derived from "NP-auxiliary-not either" by preposing the negated constituent not either, which in turn causes the inversion. Like full sentences containing inversion, such tags cannot be embedded:

- (8) \*Bill didn't come to the party because neither did Mary.  
 \*John thought that Bill hadn't come, and that neither had Mary.  
 \*Mary doesn't know why Susan is leaving, and we don't know  
 why is she either.

The affirmative tag "NP-auxiliary-too" can also be paraphrased by

preposing too and changing it to so, yielding, after inversion, "so-auxiliary-NP." Again, the inverted form can't be embedded.

- (9) \*I am in great danger, and the knowledge that so are you  
isn't very comforting.  
\*I'm worried, and I'm sure so are you.

Inversion in negative imperatives also takes place only in a root S or in a conjunct S immediately dominated by an S:

- (10) Don't you be so impolite!  
Don't you talk like that, or I'll send you home!  
Don't anybody move!

Another class of S's which are not strictly speaking the highest S's and in which subject-auxiliary inversion applies are the "reported sentences" or "quotes" of direct discourse.

- (11) John said, "What should she eat?"  
The man asked, "Can my son have a key?"  
She exclaimed, "Isn't it cold out!"

As we proceed, we will see that the class of S's in which subject-auxiliary inversion regularly occurs in English is also the class of S's in which a great many other rules also apply. The purpose of this chapter is to enumerate and study this class of rules, which I will call "root transformations." For this, we need two definitions.

Definition From this point on, a root will mean either the highest S in a tree, an S immediately dominated by the highest S, or the reported S in direct discourse.

I do not rule out the possibility that the last condition in the preceding definition is superfluous, since the surface structure of direct discourse may well be as in (12).

(12)

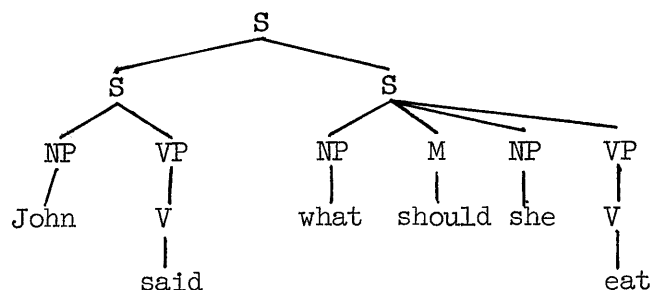

In the cases so far covered, a root S immediately dominated by another S is set off by commas. We will be able to extend this to other cases as we proceed.\*

---

\* Something should be said here about the inversions that occur after the S-introductory words than and as. The auxiliary inversion that occurs in "sentence relatives" introduced by as is to be expected, since these S's are probably root S's.

John must do his own laundry, as must every student here.

I was looking for faults in his presentation, as was my friend.

Comparative clauses introduced by than and as are not root S's. They therefore should not exhibit inversion according to the rules of Modern English proposed in this paper. If the following sentences are completely regular and to be accounted for by the subject-auxiliary inversion rule, there is a deficiency in my analysis.

We saw the same man as did John

She hasn't bought as many souvenirs as has her husband.

She spoke more convincingly than did Harry.

?Bill seems smarter in math than does Harry in science.

?The Chinese are as ready to fight as are the Japanese to talk.

\*I hope you found the play more interesting than did we.

\*Our friends can't afford to buy records as often as can you.

\*John likes Beethoven more than do I.

\*He'll cut more cake than will Mary be able to eat.

However, the fact that pronouns cannot invert in the above sentences indicates that subject-auxiliary inversion does not operate the same way in as and than clauses as it does in questions, exclamations, etc. Furthermore, even the acceptable sentences with inversion are somewhat less acceptable than their counterparts without inversion:

We saw the same man as John did.

She hasn't bought as many souvenirs as her husband has.

She spoke more convincingly than Harry did.

Bill seems smarter in math than Harry does in science.

The Chinese are as ready to fight as the Japanese are to talk.

Another difference between inversion in as and than clauses and normal subject-auxiliary inversion is that the former is optional and the latter is obligatory.

For these reasons, I am willing to regard the as and than clauses (other than sentence relative as clauses) that exhibit inversion as either not fully grammatical in English or as derived by means of some secondary inversion rule which is not a root transformation but rather a "minor movement rule" of the type defined and described in Chapter V.

Definition A root transformation is one in which any constituents moved, inserted, or copied are immediately dominated by a root in the derived structure.

Of course, to simply enumerate a class of grammatical rules which have a certain property, as I will do in the remainder of this chapter, is without empirical interest, if nothing further can be said about the rules which do not have the property. However, I will try to show in subsequent chapters that non-root transformations are subject to severe restrictions, so that the class of possible grammatical transformations which can attach nodes to non-roots is greatly narrowed. In the remainder of this chapter, I want to precisely delineate that class of transformations in English (root transformations) which will not be subject to the constraints on <sup>other</sup> transformations proposed later in this study.\*

Our first example of a root transformation is of course subject-auxiliary inversion. On the other hand, it should be clear that a great many well-known transformations are not root transformations. For example, the passive transformation, affix movement, and wh fronting, as these have been formulated in transformational literature, are not root transformations, since they can apply in embedded sentences freely.

I.4 Verb Placement in German German is in interesting contrast to English with regard to the placement of the verb. In German, the

---

\* In a theory which distinguishes between "cyclic" and "last cyclic" transformations, it is clear that every root transformation is last-cyclic, although the converse is not necessarily true. There are problems connected with these notions which I will not treat here. It would be extremely interesting if the class of root transformations and the class of last-cyclic rules were co-extensive.



finite verb, i.e., the verb which carries the tense ending, is generally in second position in a root.

- (13) Gestern ist er nach Hause gekommen.  
 Welches Buch können die Studenten nehmen?  
 Mit einem Messer wird er den Kuchen schneiden.  
 Hans stahl ein Buch.  
 Mich hat er geschlagen.

In embedded (non-root) sentences the finite verb is last in the verb phrase. (In this section, "last" means "last except for sentence complements.")\*

- (14) Ihm tat es leid, dass er gestern nach Hause gekommen war.  
 Er weiss nicht, welche Bücher die Studenten genommen haben.  
 Er wird mehr Kuchen mit dem Messer schneiden, als ich essen kann.  
 Weil Hans einen Bleistift gestohlen hat, wird er bestraft.  
 Dass er ein Auto stehlen würde, erstaunte seine Eltern und seinen Lehrer.

If the German verb is last in its clause in deep structure, as argued in Bierwisch (1963), the rule which moves it to second position in root S's can be formulated as a root transformation. That is, the V moved can be attached to the highest S. The alternative position would be to assume that the German verb is generated in second position by

---

\* German has two indirect discourse constructions. In one of these, the reported sentence is like other non-root S's in that it is introduced by dass, its verb is in final position, certain fronting transformations cannot occur in it, etc.

Er sagte dass er krank sei.

\*Er sagte dass gestern er nach Hause gekommen sei.

\*Er sagte dass mich sie geschlagen habe.

In the other type of indirect discourse, the reported sentence, like the reported sentence in direct discourse, is a root S. The verb is second, certain fronting transformations can apply; dass does not introduce the clause, and the clause is set off by a comma.

Er sagte, er sei krank.

Er sagte, gestern sei er nach Hause gekommen.

Er sagte, mich habe sie geschlagen.

the phrase structure rules and is moved, in non-root S's only, to final position in the VP. Cf. Ross (1967).

The constraints I will place on movement transformations in embedded sentences in subsequent chapters are in fact inconsistent with this latter assumption, as they will in principle exclude such a movement rule. (At the same time, they predict that a rule moving the verb from final position to second position could only apply in root S's.) Thus, if the constraints on transformations which I will propose in this study are correct, the German verb must be last in its clause in deep structure.

I.5 Tag Questions A tag question is a declarative sentence, followed by a repetition of the first auxiliary (do if the preceding declarative has no auxiliary) and a pronominalized form of the subject. Thus, some typical tags in tag questions are shouldn't he? hasn't he? did they? were you? etc. Two rules are probably involved in forming tag questions: a tag formation rule copies an entire declarative sentence with probably the addition of whether (deleted, as usual, in roots in surface structure)\*, and the subsequent deletion of what follows the first auxiliary is due to an independently motivated "VP deletion" rule.

- (15) Mary had come, hadn't she?  
 Mary won't buy this dress, will she?  
 Bill dates someone, doesn't he?  
 You were dissatisfied, were you?

I assume that the surface structure that results from the tag formation rules is as in (16). The fact that the right-hand S in (16)

---

\* I am ignoring the problems associated with positioning NEG correctly in these constructions.

is a root means that subject-auxiliary inversion may apply. Also, the comma that sets off the tag from the preceding declarative is consistent with the remark about commas and root S's made in section I.3.

(16)

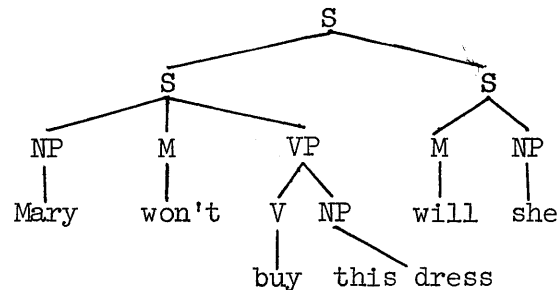

The tag formation rule itself is a root transformation, since tag questions are never non-root S's; the highest S immediately dominates the tag S.

- (17) \*Bill wanted to know whether Mary had come, hadn't she?  
 \*Bill asked if he could date someone, could he?  
 \*The question of who Mary dates, doesn't she, doesn't bother him.  
 \*The idea that Bill knew whether Mary had come, hadn't she,  
 is preposterous.

Sometimes the tag S is a copy of the complement to I imagine, I suppose, I guess, etc., as in (18).

- (18) I imagine he is dating my wife, isn't he?  
 I guess he likes foreign beers, doesn't he?

However, the definition of a root transformation only demands that the constituents copied by tag formation be immediately dominated by a root S in derived structure. There is no reason to believe that the tags in (18) are not so attached, given the examples of (19).

- (19) The idea that I imagine he is dating my wife (~~isn't he~~)  
 bothers him.  
 The foreign beers that I guess he likes (~~doesn't he~~) are  
 expensive.

I.6 Adverb Preposing Several kinds of adverbs may be preposed in a sentence. A basic division can be made between those which, in preposed position, are followed by an optional (sometimes obligatory) comma or breath pause, and those which are not. This division is further justified by noting that the former class never causes inversion in the main clause, while the latter class in almost every instance does.

Possible deep structure sources for the former class of adverbs, and the question of whether they can freely appear in embedded sentences will be discussed in section IV.1.2; I will say no more about them here. The latter class, which we can call inversion adverbs, results from root transformations, and hence is subject matter for this chapter.

I.6.1 Negated Constituent Preposing Preposed negative constituents, which are sometimes NP's but are usually adverbs, cause subject-auxiliary inversion and are never separated from the main clause by a comma.

- (20) Under no conditions may they leave the area.  
 Never have I had to borrow money.  
 At none of the beaches are the lifeguards alert.  
 Only on weekends did I see those students.  
 It was expensive, but seldom has John been so pleased.  
 Few movies have we enjoyed so thoroughly.  
 Nothing did I see that I liked.  
 In not many years will Christmas fall on Sunday.  
 (Cf. In not many years, Christmas will fall on Sunday.)

Examples generally indicate that this preposing is limited to S's which are roots.

- (21)\*        \*If under no conditions may they leave the area, how can they  
                     pay their debt?  
 ?I have worked so hard that never have I had to borrow money.  
 \*The proof that at none of the beaches are the lifeguards alert  
                     is that there have been many fatalities.  
 \*The students that only on weekends did I see are living in the  
                     country now.  
 ?We wouldn't do it again, even though seldom has John been so  
                     pleased.  
 \*The employees are happy that in not many years will Christmas  
                     fall on Sunday.

I.6.2 Directional Adverb Preposing    If the verb of a sentence is in the simple past or present tense (no auxiliaries being allowed), a prepositional phrase indicating spatial direction may be preposed. This includes adverbs of direction which, like other adverbs of time and space, will be considered intransitive prepositions in this paper. (For example, away, around, down, etc.) This construction seems limited to exclamatory statements. Also, the simple present seems to paraphrase the present progressive of sentences with normal word order.

---

\* Some of the examples of (21) do not sound totally unacceptable. However, the fact that auxiliary inversion clearly occurs after wh constituents only in roots indicates that such examples may not be strictly grammatical.

Moreover, the general heuristic subscribed to here for classes of sentences of doubtful grammaticality (acceptability judgments in such classes being erratic) is that they are ungrammatical, provided that they are not semantically difficult or of undue length or embedding. The reason for this is that it would be hard to explain even slight unacceptability for sentences that are relatively short and simple, semantically clear, and perfectly grammatical. But it is to be expected that intelligent language users would possess strategies of interpretation to render sentences that are relatively short and simple, semantically clear, and slightly ungrammatical perfectly understandable and nearly perfectly acceptable. According to this heuristic then, I take the sentences of (21) to be ungrammatical.

- (22) In came John!  
 Down the street rolled the baby carriage!  
 Up trotted the dog!  
 Round and round spins the fateful wheel!  
 Here he comes! (Cf. the synonymous "he is coming here.")  
 Away they ran!

Substituting verb forms containing auxiliaries into (22) produces ungrammatical examples.

The sentences of (22) are not obtained by simply exchanging the first and last constituents of the corresponding declaratives, since pronoun subjects are not inverted. Rather, two processes seem involved; the first is the preposing of the adverbial PP, which is perhaps part of some other rule, and the second is the movement of the simple verb into second position. This is similar to the movement of the auxiliary into second position after the preposing of wh and negated constituents. (Cf. section I.3.) I will call this subject-simple verb inversion (because no auxiliaries can be involved); at the point of this inversion in a derivation, the pronoun subject is apparently already attached to the verb form as a prefix, so that the verb is already in second position after the preposing of the directional adverb.

Both of these rules, directional adverb preposing and subject-simple verb inversion, take place in the highest S; i.e., they are root transformations.

- (23) \*I noticed that in came John.  
 \*It seems that away they ran.  
 \*The fact that down the street it rolled amazed her.  
 \*I was surprised when up trotted the dog.

Simple verb inversion cannot be combined with auxiliary inversion because (i) in this case, if an auxiliary is present, the rule does not

apply, whereas in the other case, the rule only applies to auxiliaries, and (ii) pronominal subjects do not count as taking up the second position in simple verb inversion, but in auxiliary inversion they do.

Actually, it is hard to combine even the preposing of the directional adverb with any other rule, because it depends on the sentence's verb form not containing any auxiliaries, and no other adverb preposing rule has this proviso.

- (24)        \*In John was coming!  
              \*Down the street the baby carriage was rolled!  
              \*Here he does come!  
              \*Round and round the wheel has spun!  
              \*Away they didn't run!

It appears therefore that directional adverb preposing and subject-simple-verb inversion are distinct rules, and that moreover they are respectively separate from other adverb preposing rules and subject-auxiliary inversion. If this is true, two adverb preposing rules are root transformations, negated constituent preposing and directional adverb preposing, and two subject inversion rules are root transformations, subject-auxiliary inversion and subject-simple verb inversion. Although directional adverb preposing never occurs without subject-simple verb inversion, the latter has another use, as described in the following section.

## I.7 Paranetical Clauses

I.7.1 Another Use of Subject-Simple Verb Inversion A main verb in English without auxiliaries inverts over the (non-pronoun) subject (i) if a directional adverb is preposed, as discussed above, and (ii) if part of a direct quote which in deep structure is a complement to

this verb is preposed. The identical conditions on absence of subject pronouns and auxiliaries leave little doubt but that a single rule is involved. This inversion is optional in most dialects. (Nothing depends on this in what follows.)

- (25) In John came!  
 Down the street the baby carriage rolled!  
 Round and round the fateful wheel spins!  
 Into the parking lot the car lurched!  
 There John goes!  
 ?Up the dog trotted!

In case (ii), the inversion is clearly optional, since normal or inverted word order is allowed in (26).

- (26) "John may come," said Mary, "but he will not be welcome."  
 "John may come," Mary said, "But he will not be welcome."  
 "On weekends," exclaimed Bill, "I really feel lonely."  
 "On weekends," Bill exclaimed, "I really feel lonely."

Of course, if the conditions for subject-simple verb inversion are not satisfied, normal word order must be used.

- (27) \*"John may come," said they, "But he will not be welcome."  
 \*"On weekends," did Bill exclaim, "I really feel lonely."

The examples of (23) show that one use of subject-simple verb inversion can not occur in embedded sentences. Its use with preposed quotes cannot be embedded either:

- (28) \*"The game is over," I think exclaimed Bill.  
 \*I know that, "let's get out of here," shouted John.

Thus, subject-simple verb inversion is a root transformation in all its uses.



I.7.2 Quote Preposing When part or all of a direct quote is placed at the beginning of a sentence so that it precedes the clause in which it was originally embedded as in the examples of (26), this latter clause is then called a **parenthetical**, or, more accurately, a **direct quote parenthetical**. These parenthetical clauses are clearly the highest S in deep structure (the entire quote being a complement to the verb in the parenthetical), and, as the possibility of subject-simple verb inversion in (26) shows, they are the highest S in surface structure also. (This is not circular because we demonstrated in connection with directional adverb preposing that this inversion was a root transformation.)

Therefore, for examples like (29), the deep structure is (30). As was pointed out in section I.3, the circled S in (30), at least when the rule of subject-auxiliary inversion is reached, is a root.

- (29) "John will buy any dress," Sue said, "which he thinks Mary likes."  
 "John," said Sue, "will buy any dress which he thinks Mary likes."

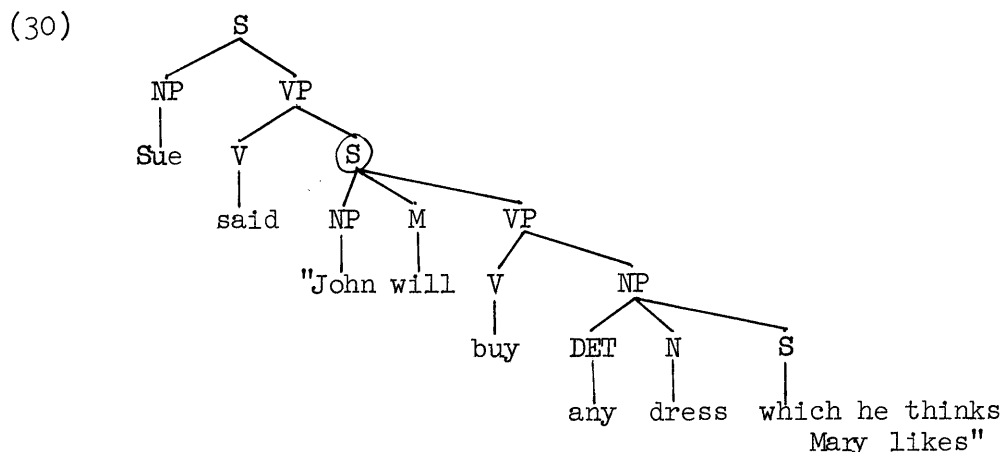

For explicitness, I assume that direct quote preposing works as follows: when part of the circled (root) S in (30) is preposed, both this part and the part left behind are dominated by S, as in (31). (Circled S's

in (31) are roots.)

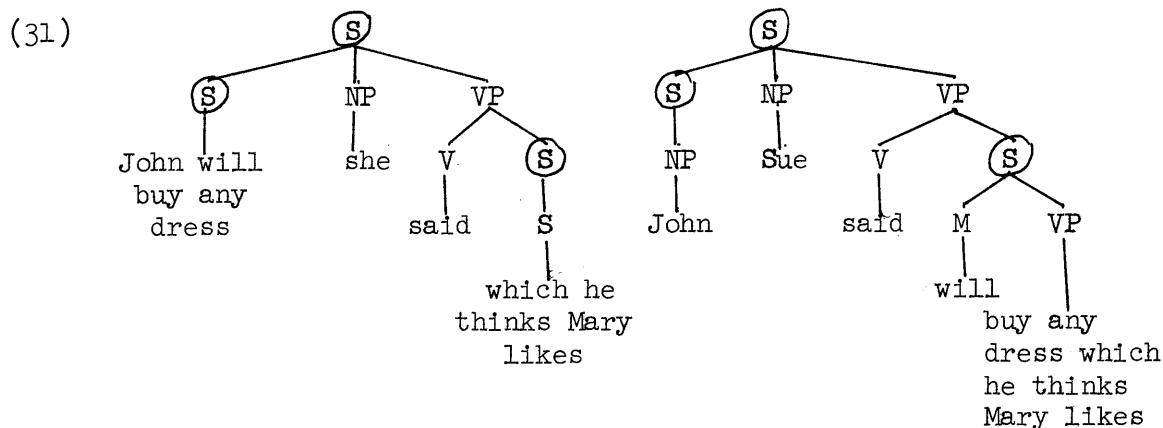

The non-branching S's in (31) are pruned (absent) in surface structure.

The comma or breath pause which separates the parenthetical from the quote material is predictable from the presence of root (circled) S's in (31). Since some of these roots can be pruned, it would appear that the comma is present before pruning.

The most important observation to be made is that this preposing of part or all of a quote is a root transformation. For the preposed material must be moved to the front of the entire sentence, which implies that it is attached to the root S. (No one would claim that the preposed quote is attached to the subject NP.)

- (32) \*I think, "The game is over," Bill exclaimed.  
 \*I started, "I like beef," to say, "but not beef liver."  
 "The game is over," I think Bill exclaimed.  
 "I like beef," I started to say, "but not beef liver."

Incidentally, the examples in (33) indicate that a condition on this rule is that the quote be sentence final in the deep structure; this has no bearing on matters here.

- (33) John said, "I know I'm guilty, but I shouldn't be punished,"  
       just to attract attention.  
       "I know I'm guilty," John said, "but I shouldn't be punished."  
       \*"I know I'm guilty," John said, "but I shouldn't be punished,"  
       just to attract attention.

It will be obvious when the constraints on non-root transformations are defined in subsequent chapters that direct quote preposing violates such constraints. My general claim then would predict that direct quote preposing should always attach material only to roots. This is borne out, as shown above, and moreover my analysis is consistent with the appearance of verb inversion in, and commas around, the parenthetical clause itself.

I.7.3 Non-factive Parentheticals There is another kind of parenthetical besides the direct quote parenthetical, which almost certainly is related to it. Some interesting properties of this construction have been studied by Rardin (1968).

The construction results from placing part or all of certain non-factive complements at the beginning of a sentence so that this precedes the clause in which it was originally embedded. Some typical non-factive parentheticals are it seems to me, it is true, we can assume, one would think, it is believed, I don't doubt, etc. Any of these, for example, can be inserted in (34) at the blank.

- (34) John will buy any dress, \_\_\_\_\_, which he thinks Mary likes.

In many cases, the positions in which a non-factive parenthetical can occur are just those where a direct quote parenthetical occurs. (Cf. (29)). If and how these two types of parentheticals differ in their distribution

cannot be determined by a few more random examples, so I will leave the pursuit of this matter to the reader's curiosity. But the similarity is striking enough to lead us to believe that the syntactic analyses for the two cases must be parallel.

Among other things, it is easy to show that non-factive preposing is like direct quote preposing in that it too is a root transformation. Parallel to the non-grammatical examples of (32) are those of (35):

- (35) \*It amazed me that a criminal, they claimed, had no rights.  
 \*John replied that we had forgotten, it seemed to him, our origins.  
 \*The fact that the economy, we were led to believe, was sound caused us to invest in stocks.

If non-factive preposing were not a root transformation, the examples of (35) would be grammatical paraphrases of those in (36).

- (36) It amazed me that they claimed a criminal had no rights.  
 John replied that it seemed to him we had forgotten our origins.  
 The fact that we were led to believe the economy was sound caused us to invest in stocks.

My analysis of non-factive parentheticals would be roughly the same as that given for direct quote parentheticals. The material preposed as well as that left after the parenthetical clause are dominated by S's. At least the preposed material is dominated by a root S (since this S is immediately dominated by the highest S). Thus, the surface structure of (34), with the S which is pruned out circled, is as in (37).

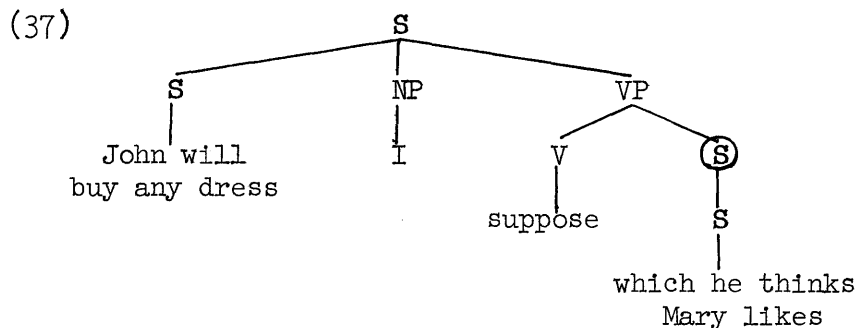

The fact that the parenthetical clause and the preposed material are both under root S's is attested to by the inversion which is sometimes possible in one or both clauses. (I make no attempt to predict such inversions; this analysis predicts only that they are possible.)

- (38) Will John buy any dress, do you suppose, which he thinks  
Mary likes?  
John is quite a bore, don't you think?  
Will he come in, I wonder, right during the dinner?

A final group of sentences should be mentioned.

- (39) Would her father die at night, Mary wondered, or would he  
survive until daybreak?  
(40) Mary wondered if her father would die at night or if he would  
survive until daybreak.

It seems unlikely that (39) is derived from (40). If it were, we could not explain why the S complement to wonder in (40), which is not a root, suddenly becomes a root in (39). I.e., why is there inversion in the second clause in (39) but not in (40)? Rather, it is more plausible that (39) is derived from (41); the construction exhibited in (41) is analogous to the indirect discourse without dass construction in German in that the complement S of wonder is a root S.

- (41) Mary wondered: would her father die at night or would he  
survive until daybreak?

## I.8 Some Other Preposing Rules

### I.8.1 Topicalization Consider the following sentences:

- (42)        These steps I used to sweep with a broom.  
               Each part John examined carefully.  
               Our daughters we are proud of.  
               Poetry we try not to memorize.

These examples result from a transformation called "topicalization," which moves noun phrases to the front of the sentence; that is, it attaches them to the highest S. This transformation is a root transformation, since examples like (42) cannot be embedded.

- (43)        \*Have I shown you the broom (that) these steps I used to  
    sweep with.  
               \*I fear (that) each part John examined carefully.  
               \*We are going to the school play because our daughters we  
    are proud of.  
               \*Are you aware (of the fact) that poetry we try not to memorize?  
               \*Do you think Socialist theory many Czechs would deny?  
               \*That this house he left to a friend was generous of him.

### I.8.2 VP Preposing Consider the following sentences:

- (44)        Mary once predicted that John would pass an exam eventually,  
    and pass one he now has.  
               John hoped that Mary would find his hat, but find it she  
    could not.  
               John intends to make a table, and make one he will.  
               We thought someone would fail the exam, and fail it plenty  
    of people have.

These sentences are derived from the structures underlying those in (45) by preposing a VP to the front of an S. I will show in Chapter IV (as I have mentioned previously) that the first auxiliary have, be, or do is outside the VP in M position when rules like this apply to VP; hence, the rule is not overly complicated.

- (45) Mary once predicted that John would pass an exam eventually,  
and he now has passed one.  
John hoped that Mary would find his hat, but she could not  
find it.  
John intends to make a table, and he will make one.  
We thought someone would fail the exam, and plenty of people  
have failed it.

The rule in question, VP preposing, cannot apply in non-root S's.

- (46) Mary once predicted that John, who now has passed an exam,  
would pass one eventually.  
\*Mary once predicted that John, who pass(ed) an exam now has,  
would pass one eventually.
- John hoped that Mary would find his hat, but I wonder how she ever  
could find it.  
\*John hoped that Mary would find his hat, but I wonder how find  
it she ever could.
- \*John intends to make a table, and his wife thinks that make one  
he could.  
\*John intends to make a table, and we're afraid that make one he  
will.  
\*John intends to make a table, and I'll get the materials so that  
make one he can.
- \*We were looking for someone who failed the exam, and now we've  
found someone who fail(ed) it (he) has.

Thus, VP preposing is also a root transformation.

I.9 Right and Left Dislocation In this section, we consider rules  
which remove NP's from their ordinary position in sentences, set them off  
by **commas**, and replace them with pronouns. One such rule, "left dis-  
location", moves an NP to the beginning of the sentence.

- (47) This room, it really depresses me.  
John's sister, she won't do anything rash.  
Bill, you ought to see a doctor. (May be a different rule)  
These clams, I buy them right at the shore.  
This movie, I told you you wouldn't like it much.  
Jane, she visits this park every weekend.

This rule apparently attaches NP's to the highest S; if this condition is not fulfilled, the impression is that of broken speech.

- (48) \*I told you that this movie, you wouldn't like it much.  
 \*Bill hopes that John's sister, she won't do anything rash.  
 \*They put so much furniture in here that this room, it really depresses me.  
 \*The fact that these clams, I buy them right at the shore means that they are sure to be fresh.  
 \*I'm afraid that Bill, you ought to see a doctor.  
 \*He doesn't like the park that Jane, she visits it every weekend.

I conclude that left dislocation is a root transformation.

Corresponding to left dislocation there is a rule of right dislocation, as exemplified in (49).

- (49) It really bothers me, John's big cigar.  
 She won't do anything rash, John's sister.  
 You ought to see a doctor, Bill.  
 I buy them right at the shore, these clams.  
 I told you you wouldn't like it much, this movie.  
 Jane visits it every weekend, this park.

The crucial examples for determining whether or not right dislocation is a root transformation are trees which have an embedded sentence which is not rightmost in a constituent (NP or VP) immediately dominated by a root. An S which is rightmost in a subject NP or in a VP immediately dominated by a root does not qualify because the right "dislocated" NP could be attached to the root, as in (50). (On the other hand, if (50) is unacceptable, it may mean that right dislocated NP's only appear on the right of the highest VP; thus, we can conclude nothing from (50).)



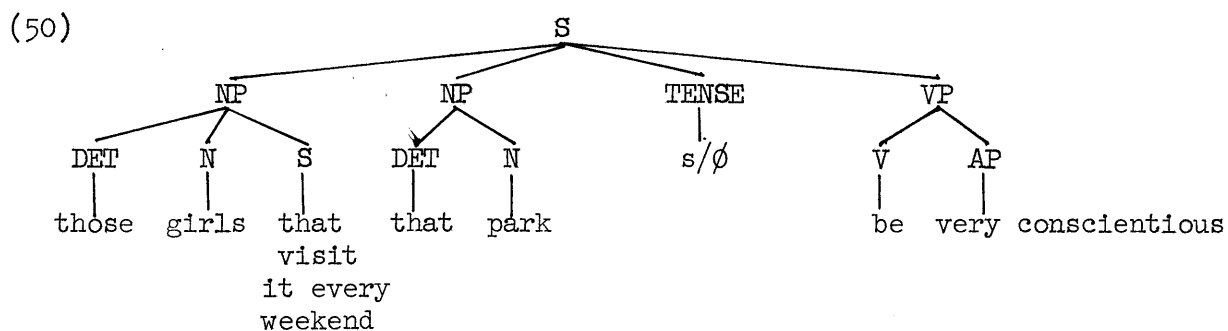

Crucial examples are therefore those in (51).

- (51)
- \*John has sold the garage that you store it in, that old car, to Mary.
  - \*I predicted that her attempt to do something daring, John's sister, would end in disaster.
  - \*The fact that the girl Bill bought it for, the camera, is visiting him doesn't seem to improve his disposition.
  - \*He doesn't realize that the girl he bought it for, the camera, doesn't like him.
  - \*I didn't say that it bothered me, riding in the back seat, on the trip out.
  - \*John gave the boy she used to go out with, his girl friend, a dollar.

Since these crucial examples are ungrammatical, I conclude that right dislocation is a root transformation. But I leave undecided the question of whether it can attach NP's between the subject NP and the VP, as in (50).

I.10 Preposing around Be In this section, I will discuss some constructions that are not so clearly root transformations, as are those previously discussed. These constructions throw into relief rather the possibility of falsification of the hypothesis which I will propose in subsequent chapters, and ways in which other syntactic or semantic processes may interrelate with the constraints on transformations I will propose. The rules which produce these constructions are not

structure-preserving, according to the definition of that term to follow in Chapter II; nonetheless, they sometimes (not always) can apply in non-root S's in normal English speech. In order to retain the hypothesis I will make, that non-structure-preserving major constituent movement rules must be root transformations (the "structure-preserving constraint"), I will be forced to assert that the use of these rules in embedded sentences is ungrammatical in the strict sense, and that the structure-preserving constraint is being broken for purposes of emphasis, clear communication, etc. Since I am not in a position to be able to characterize the conditions under which ungrammatical sentences can be used, my theory, in the only sense that I can make it precise, does not always coincide with judgments of acceptability. However, it seems likely to me that the way to correct it is to study the conditions under which the structure-preserving constraint can be broken, and not to abandon the constraint itself.

Consider first the rule by which predicate adjective phrases whose heads are compared by means of more, less, most, least, or as are permuted with the subject NP. (Whether or not the rule operates in sentences which have linking verbs other than be is of no interest here.) Call this rule "comparative substitution."

- (52)        More important has been the establishment of legal services.  
               Just as surprising was his love for clothes.  
               Most embarrassing of all was losing my keys.  
               No less corrupt was the ward boss.  
               Equally difficult would be a solution to Russell's paradox.

The substitution of an AP for an NP is not a structure-preserving rule, according to the definition of this to be given in Chapter II. Therefore, comparative substitution should be a root transformation, and

constructions like those in (52) should not occur in embedded sentences. And in some embedded sentences, they are indeed unacceptable.

- (53) \*Bill wonders why more important has been the establishment of legal services.  
 \*A love for clothes that just as surprising was also got him into debt.  
 ?That equally difficult would be a solution to Russell's paradox is not at all clear.  
 \*The deputies could extort with impunity, as long as no less corrupt was the ward boss.

In other instances, however, the sentences of (52) sound acceptable when embedded, at least to some speakers.

- (54) ?We convinced the authorities that more important would be the establishment of legal services.  
 ?Your admission that just as surprising was his love for clothes indicates a lack of understanding.  
 ?I am sure that most embarrassing of all was losing your keys.

John Bowers has pointed out to me (personal communication) that the embedded sentences which violate the structure-preserving constraint in (54) all seem to be complements to verbs, nouns, or adjectives which report attitudes or statements of their subjects; i.e., these verbs, nouns, and adjectives are functioning to introduce indirect discourse. If part of the meaning of a sentence is to be found in the surface order of elements (for a discussion of this possibility see Chomsky (1968) and Jackendoff (1969)), then the simplest way to report this meaning in indirect discourse would be to break the structure-preserving constraint and reproduce this order directly.

By mentioning the possibility of an explanation along these lines, I do not mean to deny that the structure-preserving constraint, as it now stands, makes some doubtful predictions about the sentences in (54).

But as I said above, the proper path for further study would seem to be investigation of the conditions under which the constraint can be broken. In the great majority of cases, as we will continue to see, the constraint makes just the right predictions; for example, if the constraint were abandoned, what would explain the ungrammaticality of the sentences in (53)?

Another rule which preposes constituents around be we might term "participle preposing." In section II.2 I will give evidence that what follows the progressive or passive uses of be is a single sister constituent to be (a VP). The sentences of (55), which have limited use in English, seem to corroborate this contention.

- (55)      Speaking at today's lunch will be our local congressman.  
 Taking tickets at the door was a person I had previously roomed with.  
 Examined today and found in good health was our nation's first executive.  
 Taking turns, as usual, were his two sisters.

Inasmuch as participle preposing is used as a rule of English, it seems to exhibit root transformation behavior quite clearly.

- (56)      \*Bill wonders why speaking at today's lunch will be our local congressman.  
 \*The person who taking tickets at the door was had roomed with me at Yale.  
 \*Since examined today and found in good health was our nation's chief executive, we can all breathe more easily.  
 \*The fact that taking tickets at the door was my old Yale roommate made it easy to get in.  
 \*Bill said that taking turns, as usual, were his two sisters.  
 ?Bill announced that speaking at today's lunch would be our local congressman.

A third transformation which permutes constituents with subject NP's over be (and a few other verbs, in this case) is a rule which we

can call "PP substitution."

- (57) In each hallway is (hangs, has long stood) a large poster of Lenin.  
 Among the guests were (sat) John and his family.  
 On the porch is a large wicker couch.  
 Upstairs is (stands, lies) all the wine we bought in Europe.  
 Here will be (will stand) the memorial to the war dead.

Since PP substitution is not a structure-preserving rule (according to the definition of Chapter II), it should be, according to the structure-preserving constraint, a root transformation. And, as was the case with comparative substitution, there are embedded S's in which it may not operate.

- (58) \*I have no idea how often among the guests were (sat) John and his family.  
 \*The posters that in each hallway are (have long stood) subtly influence the children.  
 \*That here will stand a memorial to the war dead upsets the pacifists.  
 \*I won't be satisfied until upstairs is all the wine we bought in Europe.  
 \*Now that on the porch is a large wicker couch, we can all relax.

However, there are also cases of acceptable embedded sentences which exhibit PP substitution (at least for some speakers).

- (59) ?The belief that in each hallway is (hangs, has long stood) a large poster of Lenin is erroneous.  
 ?She convinced Bill that among the guests were (sat) John and his family.  
 ?Bill is happy that on the porch is a large wicker couch.  
 ?I've noticed that upstairs is (lies) all the wine you bought in Europe.  
 ?Bill was just explaining that here will be (will stand) a war memorial.

I believe that what was said earlier vis-à-vis comparative substitution is also appropriate here. It should be remarked that the

contexts in (53) and (58) are similar, as are those in (54) and (59). It seems to me that the structure-preserving constraint which I will state in the next chapter (that rules like PP substitution can apply only in root S's) should be retained in its simple form, and efforts should be made to isolate special properties of the rules and lexical items involved in (54) and (59) to see what allows this constraint to be broken.

Conclusion to Chapter I A large class of transformational rules of highly specific character, the class of root transformations, has been isolated. These rules attach constituents only to root S's. (One could define the traditional grammatical clause "independent clause" as a clause in which root transformations apply.) In Chapter III, one further important root transformation will be added to our list, and still another will be discussed in Chapter IV. In Chapter III, we will also see that further general restrictions can be placed on the class of root transformations.

I will now try to show how the class of non-root transformations of English can be constrained in an empirically interesting way.

## CHAPTER II: STRUCTURE-PRESERVING NP MOVEMENT TRANSFORMATIONS

In Chapter I, I defined a root transformation, and I enumerated and discussed the root transformations of English. In this chapter, I will define, in the course of discussing the English passive construction, a structure-preserving transformation. The bulk of the chapter will then be given over to showing that almost all the (non-root) transformations of English which move NP's should be formulated so as to be structure-preserving. For many transformations, this means only a trivial formal modification in the generally accepted formulations of these rules, while for others, it will involve showing inadequacies in accepted formulations which can be removed by assuming that they have the structure-preserving property.

In following chapters, I will discuss transformations which move other nodes besides NP's, and show that they too have the structure-preserving property. Again, in some cases, accepted formulations need major revisions. But in each case of a major revision, evidence that this revision is necessary will be presented.

Ultimately, the claim of this paper is that every non-root transformation is structure-preserving, unless it is in the highly restricted class of minor movement rules yet to be defined. As might be expected, presently accepted notions of grammatical structure must in many cases be modified in order to make our claim hold in general. Although one or two of these modifications will weaken our initial claim to some degree, the narrowing of the notion "possible transformational rule" that emerges from this study is considerable.

## II.1 The Passive Construction

### II.1.1 The Active-Passive Relation in English Transformational

grammarians generally agree that English contains a "passive" rule relating pairs of sentences like the following:

- (1) (a) Russia defeated Germany.  
 (b) Germany was defeated by Russia.

Furthermore, there is agreement that the trees corresponding to (1a) and (1b) after the application of the passive rule are (2) and (3), respectively. (There is disagreement over the status of the passive auxiliary be, which will be returned to later; in (3) it is simply represented in ad hoc fashion.)

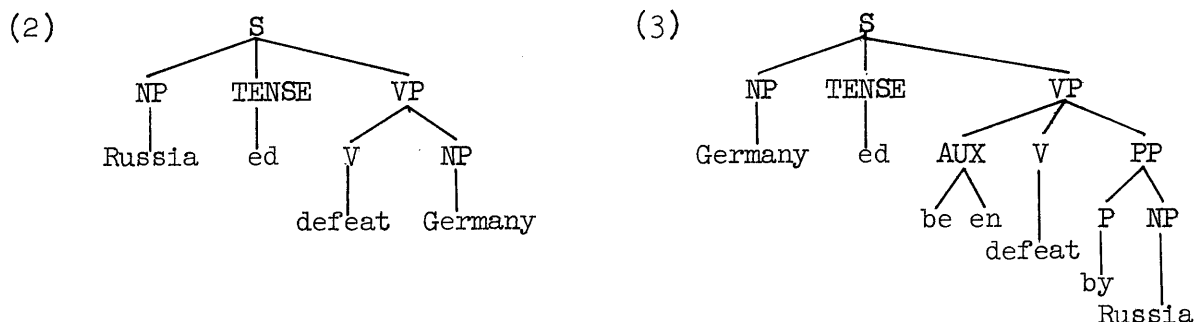

There is ample justification for assigning the structure

(<sub>PP</sub> (<sub>P</sub> by ) (<sub>NP</sub> X ) ) to an "agent phrase" like by Russia in (3). For example, it behaves like a PP in relative clauses and questions:

- (4) By whom has this book been read?  
 Who has this book been read by?  
 The people this book has been read by are not typical.

Also, this by, like other prepositions, cannot have a for-to (infinitive) object:



- (5) \*The tension would be lessened by for Europe to disarm.  
 \*The bankers would be angered by to suggest devaluation.

The relation in (1), the active-passive relation, is sometimes thought to hold also between pairs of noun phrases such as those in (6) and (7).

(6) Russia's defeat of Germany

(7) Germany's defeat by Russia

There are, however, differences between "passive noun phrases" like (7) and passive sentences. If and exactly how passive noun phrases and passive sentences are grammatically related is not of direct interest here, since I will only be demonstrating that the rule or rules which derive passive sentences from active ones have a certain property. I return to the derivation of passive noun phrases in section II.6.

There is some disagreement over what the common deep structures of actives and passives should look like. In particular, it is not certain whether the agent phrase (Russia in the preceding examples) should originate in subject position or in the by phrase. The force of what follows does not depend on the resolution of this question. However, for purposes of exposition, I will assume that agent phrases are subjects in deep structure, in line with most transformational work. Under this assumption, (3) is a transform of (2).\*

---

\* The alternative would be to assume with Fillmore (1968) that the by phrase is non-empty in deep structure and that any subject of an active which can alternatively appear in a by phrase in a passive is derived from that source by an "agent preposing" rule. In this view, the (a) and the (b) sentence below are derived from the deep structure (c).

(a) John received the letter.

(b) The letter was received by John.

A second question concerning the proper formulation of the passive rule(s) is whether, in fact, one rule which moves two NP's or two rules which move one NP apiece are involved. Again, the results of this section are neutral with respect to this question. For purposes of

(footnote cont.)

(c)

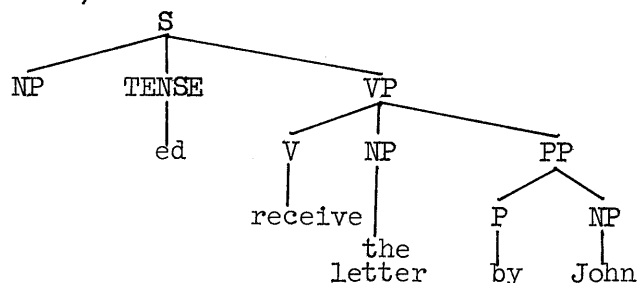

Such an analysis would have certain advantages. First, the fact that the subject NP of an S is an obligatory node means that it must be filled at some point in a transformational derivation. Thus, either NP preposing or agent preposing must apply to (c), yielding (a) or (b). (If we use the agent postposing rule adopted in the text, we must impose an ad hoc obligatory condition on NP preposing, so that agent postposing does not apply alone, leaving (c) as an acceptable surface structure.) By contrast, NP's do not have an obligatory subject NP as do S's, and the possessive transformation which plays a role similar to NP preposing need not apply inside NP structures analogous to (c): "The reception of the letter by John."

Second, an argument for agent preposing (and against agent postposing) might be constructed from the following evidence:

- (d) The {thief  
soap} slipped into the closet.  
The {bird  
dictionary} flew across the room.
- (e) The closet was slipped into by the thief.  
\*The closet was slipped into by the soap.
- (f) The room was flown across by the bird.  
\*The room was flown across by the dictionary.

These sentences show that if agent postposing is a rule, it will sometimes have to take into account the deep structure interpretation of the NP to be postposed. For while the sentences of (d) are ambiguous when they have an animate subject, the grammatical sentences of (e) and (f) are not, showing that only an agent NP can be postposed over an intransitive verb. Such a condition on a transformational rule would seem to be undesirable.

On the other hand, if agent preposing is a rule, the agent interpretation of a subject could be associated with a deep structure by phrase position, and the non-agent interpretation could be associated with the subject NP position. While this would seem to be a promising channel for investigation, I have not been able to formulate a comprehensive analysis of all the consequences of using an agent preposing rule at this time, so I will not go into the matter further.

exposition here, I will assume that one rule moves the deep structure subject NP into the by phrase, and that a separate rule moves a deep structure object into the subject position. Following the terminology of Chomsky (1970), I will call these rules "agent postposing" and "NP preposing" respectively.

II.1.2 The Structure-Preserving Property Agent postposing and NP preposing are both good examples of the structure-preserving transformations which are to be defined and studied in this chapter. Both move NP constituents into positions where NP's are permitted by independently motivated phrase structure rules. Agent postposing moves the subject NP into the NP position provided for in the rule:  $PP \rightarrow P - NP$ . NP preposing moves an object NP into the position provided for by the rule:  $S \rightarrow NP - TENSE - (M) - VP$ . This notion of moving a constituent labeled X into a position where a node X is already provided for by the phrase structure rules is the central idea in the definition of a structure-preserving transformation.

To make this notion precise, I drop the requirement that all nodes dominate terminal elements. Rather, I require only that a node dominate terminal elements at some point in a transformational derivation. Thus, trees may contain "empty" nodes like NP, S, P, etc., which dominate nothing. (These empty nodes are ignored by semantic interpretive rules and selection restrictions.)

Definition A structure-preserving movement rule is a transformation such that (i) the structural description specifies the location in trees of two nodes  $B_1$  and  $B_2$  bearing the same label X, and (ii) the structural change moves  $B_2$  and all the material dominated by it into the position

of  $B_1$ , deleting  $B_1$ .

The deletion of  $B_1$  is subject to a recoverability condition, as in Chomsky (1965), so  $B_1$  is either empty or else what it dominates is specified in the rule that deletes it. Similarly, I assume that an empty node labeled X remains in the original  $B_2$  position, and that the movement rule can specify material to be inserted into the  $B_2$  position.

Structure-preserving insertion and deletion rules can be defined analogously; an insertion specifies the location of a node in trees and replaces it with material explicitly mentioned in the rule, whereas a deletion rule specifies the location of a non-empty node in trees and removes the material it dominates, leaving an empty node. By this definition, a structure-preserving movement rule transforms

$W - (B X) - Y - (B \text{ --- }) - Z$  into  $W - (B \text{ --- }) - Y - (B X) - Z$ .  
(Of course, the movement may be from left to right or right to left.)\*

We may wish to extend the term "structure-preserving" later to any transformation which is a combination of structure-preserving transformations as we have just defined them. Of course, only certain specific kinds of combinations should be highly-valued grammatical rules. For example, one could in effect substitute a fully specified NP which lacked, however, a relative clause S for an NP which was empty except for a relative clause S by substituting a sequence DET - NUM - N - PP for a similar empty sequence. I will not introduce such extensions, however, unless they arise from the discussion of individual rules.

---

\* I don't mean to imply that any structure-preserving rule is a possible rule. Other constraints are certainly operating in the grammar. Several such constraints are proposed and discussed in Ross (1967).

An obligatory node X may be empty in deep structure, just as an optional node may be. However, an obligatory node differs from an optional one by definition in that it must be chosen. Since I require (in the second paragraph of this section) that any node dominate terminal elements at some point in a transformational derivation, it follows that obligatory nodes are just those which must be present and non-empty at some point in a transformational derivation. (Optional nodes need not be since they need not be chosen in deep structures.)

II.1.3 The Passive Rules in the Structure-Preserving Framework The agent postposing rule (or the part of the passive rule which moves the subject) moves an NP into the by phrase object position, as shown by the arrow in (8). By formulating this rule as structure-preserving (i.e., by assuming that by and an empty object NP are present in the deep structure of the passive), we can account for the derived PP structure which results from this rule without postulating any ad hoc symbols such as PASSIVE in deep structure.

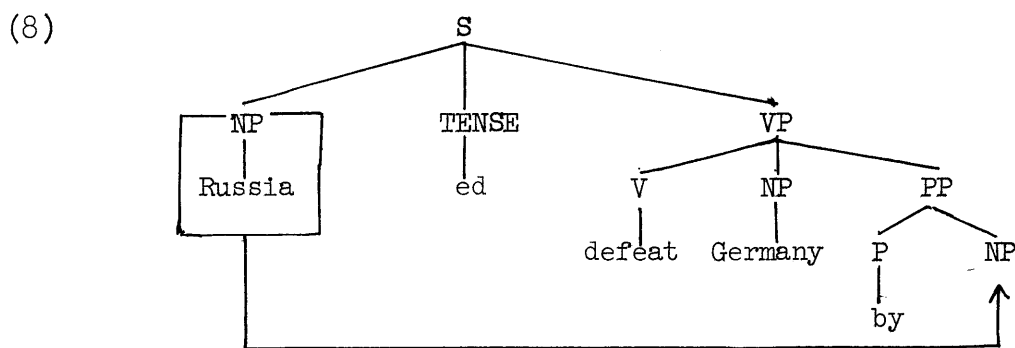

The optional phrase structure choice of a PP with the preposition by provides an empty node for receiving a postposed agent NP. This formal mechanism (essentially that utilized by Chomsky (1965) to account for

the PP structure of the by phrase) explains why the output of agent postposing results in a prepositional phrase similar to other prepositional phrases in its position under VP, in its internal structure, and in its transformational behavior.

The structure-preserving framework also provides a principled reason for why agent postposing is obligatory, once agentive by with an empty object NP is chosen in deep structure. (There are no sentences like "\*Russia defeated Germany by."\*) The agentive by is like a number of other prepositions such as with, for, toward, at, etc. (as opposed to in, around, near, locative by, etc.) in that it has an obligatory object NP. Since an obligatory node must be non-empty at some stage of a transformational derivation (not necessarily in deep structure), an object NP is always generated with agentive by in deep structure, and this NP must be filled either in deep structure or by a transformation.\*

Very often in this paper, I will be able to use the structure-preserving framework in this way to eliminate the need for stating that a given rule is optional or obligatory by means of ad hoc conditions on the rule itself. Perhaps the structure-preserving framework could give rise, in the long run, to some general claim about when rules are optional and when they are obligatory, with special conditions always being due to the phrase structure involved (sub-categorization especially might play a role) and other more general considerations. For the moment, I will limit myself to showing, at several points in the paper, how the structure-preserving constraint explains obligatory or blocking conditions on

---

\* Whether this NP is ever filled in deep structure is a separate question from our concern here.

several rules and eliminates the necessity of placing conditions of applicability on the rule itself.

One of the reasons that an attractive general claim about when rules are optional and obligatory cannot be made is the fact that the next rule to be discussed, NP preposing, is obligatory. Since the deep subject NP of a passive sentence is non-empty in deep structure (at least if the by phrase is present in surface structure), there is no reason, in the framework developed so far, why NP preposing should be obligatory. Yet it does seem that the requirement that this rule apply whenever agent postposing removes a deep subject ~~is~~ related to the fact that the subject NP of an S is an obligatory node. This problem was discussed in more detail in the last footnote of section II.1.1. In any case, NP preposing in sentences is probably not the same rule that preposes deep object NP's inside noun phrases, as in "Germany's defeat by Russia." Arguments to this effect are given in section II.6.

The important fact about NP preposing, for our purposes here, is that it is structure-preserving. It moves object NP's into the empty NP position provided for by the phrase structure rule that expands S. (I treat the passive auxiliary in totally ad hoc fashion in this section; it is discussed in more detail in later sections.)

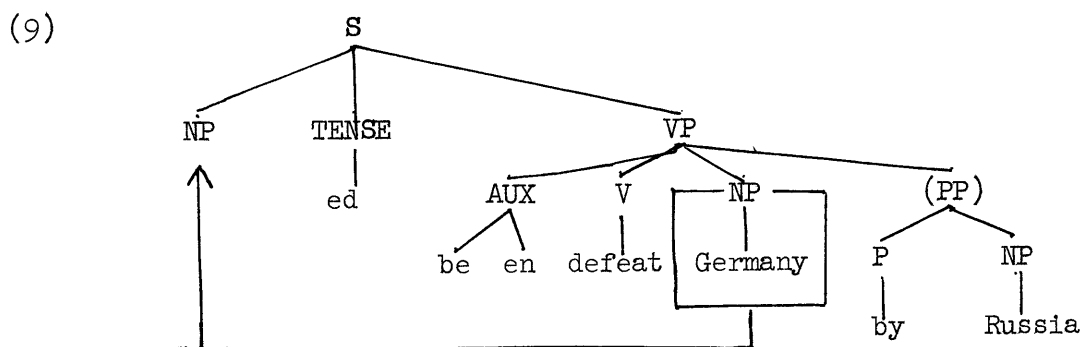

It may be well to dwell here at the outset on the importance just of showing that transformations have the structure-preserving property, even if no other problems could be resolved by this observation. The reason we want to limit transformations to being of certain types (root or structure-preserving) is that the expressive power of transformations is too great. Many hypothetical rules which are non-structure-preserving are just as easily expressed in the generally accepted algebra of transformations as those which are.

For example, let A be a hypothetical language identical to English except that the agent phrases in passive constructions are placed immediately before the passive verb or noun rather than among the other complement PP's. Thus, the grammar of A yields the following grammaticality judgments, where # signifies ungrammatical in A, and \* represents ungrammatical in English.

- (10)       Some countries couldn't defeat Germany with conventional arms.  
           #Some countries couldn't with conventional arms defeat Germany.  
           #Some countries couldn't Germany defeat with conventional arms.  
       (\*##) #Germany couldn't be defeated with conventional arms by some  
                   countries.  
       (\*##) Germany couldn't be by some countries defeated with conventional  
                   arms.
- This country's second defeat of Germany in this century.  
           #This country's second Germany defeat in this century.  
           #This country's second in this century defeat of Germany.  
       (\*##) #Germany's second defeat by this country in this century.  
       (\*##) Germany's second by this country defeat in this century.
- (\*##) #The second defeat of Germany in this century by this country.  
       (\*##) The second by this country defeat of Germany in this century.

In presently accepted transformational theory, the grammars of A and of English differ in an accidental way -- in the formulation of the agent postposing rule -- and each language is equally highly valued. But yet



English seems a more regular language in a significant way: the postposed agent PP in English appears in a typical PP position, whereas the agent PP of language A does not appear in a typical PP position. (Recall that language A has the same phrase structure rules as English.) Thus, it would seem that the evaluation measure should be revised to favor English over language A. Adoption of the structure-preserving hypothesis achieves this, since A could not be described without an ad hoc addition of a PP to the phrase structure rules for VP and NP expansion. More generally, adoption of the structure-preserving hypothesis excludes on principle any language whose transformations, like those of language A, do not "obey" its phrase structure rules in embedded sentences.

Any number of hypothetical alternatives to English can be devised whose passive rules, like those of language A, do not have the structure-preserving property. In all cases, there are fairly clear intuitions that these languages are irregular in a sense that English is not. It is this sense that the claim that non-root transformations are structure-preserving makes precise.

II.1.4 The Optionality of the By Phrase in the Passive The agent by phrase is optional in English passive constructions:

- (11) Germany was defeated (by Russia).  
       Germany's defeat (by Russia).

Transformationalists have accounted for this by postulating an optional rule which deletes by - NP. In the framework of this paper, an alternative to this ad hoc device is to attribute the optional presence of the by phrase in passive constructions to the optionality of PP under the nodes VP or NP. In this view, the deep structure of a passive lacking an agent

phrase in surface structure has an empty NP in the subject position. Agent postposing cannot apply to such deep structures since there is no empty node to move the subject NP onto. Thus, the deep structures of (12) and (13) would be (14) and (15), respectively.

(12) Germany was defeated.

(13) Germany's defeat.

(14)

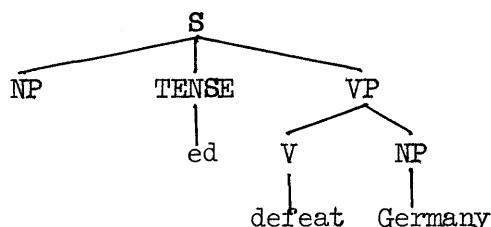

(15)

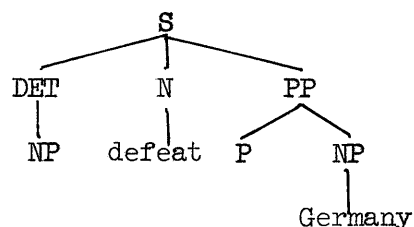

In this way, by phrase deletion can be eliminated from the grammar.

Eliminating by phrase deletion also eliminates the syntactic problem of determining what element is actually deleted in this rule. That is, in (15a), the understood agents are, respectively, everyone, someone, and his father.

(15a) John wants to be left alone in his room.  
A hitchhiker here will probably be picked up.  
He was never physically harmed by his father, but he was often threatened.

One might ask what the difference is in such a framework between the differently interpreted "the corn grew" and "the corn was grown." One possible answer is that the deep structure grammatical relation of the corn to grow is the subject relation in the first case and the object relation in the second. Another possible answer is that the deep structure of the second example contains the deep structure of the first, and also an abstract "causative" verb which is replaced by grow in surface structure.

Thus, the deep structure of "the corn was grown" would be as in (15b), while that of "the corn grew" would be as in (15c).

(15b)

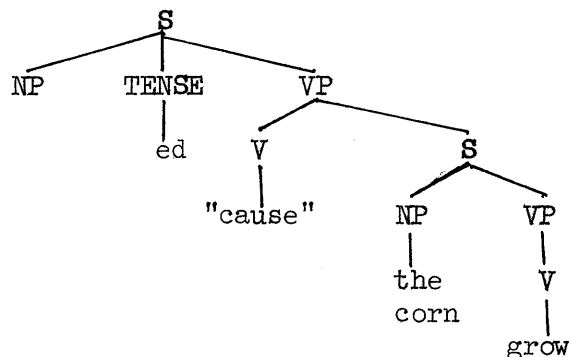

(15c)

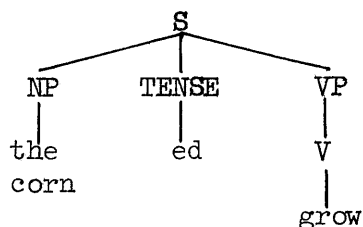

This analysis of agentless passives will also account for a verb like be born (in the sense of be given birth to, not that of be carried), which cannot appear in the active and which never occurs with an agent by phrase.

- (16a) \*This child was born by my sister on Memorial Day.  
 \*My sister bore this child on Memorial Day.

The use of the progressive with be born shows that it is a verb rather than an adjective, since the progressive is not used with adjectives formed from past participles:

- (16b) Unwanted children are being born every minute.  
 \*Unwanted children are very often being still-born.

We need only stipulate that bear (in the sense of give birth to)

may not take a deep structure subject; this has nothing to do with the fact that an (empty) subject NP appears before this verb in deep structure, once we admit the notion of empty node. Thus, the deep structure of (16c) is (17).

(16c) This child was born on Memorial Day.

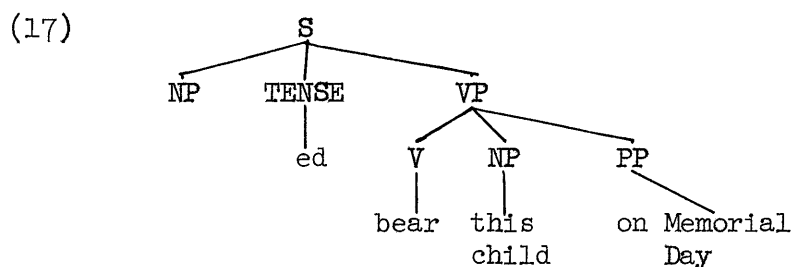

In connection with bear (give birth to), which can not have a deep structure subject, a few verbs which must should be mentioned: precede, follow, own:

- \*The dinner was preceded.
- \*The speech was followed.
- \*Some of the chairs are owned.

The normal case is that a verb may or may not take a deep structure subject.

This concludes the introduction of the concept of a structure-preserving transformation. The main purpose of this section has been to illustrate how the two NP movement transformations, NP preposing and agent postposing, which together account for the passive construction in English, satisfy what I have defined as the structure-preserving property. In the remainder of this chapter, other non-root transformations which move NP's will be shown to have this property. In Chapter IV, a number of structure-preserving transformations which move other phrase nodes (AP, S, and PP) will be studied, and in Chapter V rules which move

non-phrase nodes are discussed in some detail. All in all, almost every movement transformation which has found acceptance in transformational literature as relevant to the description of English is discussed somewhere in this paper.

## II.2 There Insertion

II.2.1 There Insertion as Structure-Preserving Transformationalists generally agree that the following pairs of sentences are transformationally related by a rule usually called there insertion.

- (18)      A small dog is in that room.  
             There is a small dog in that room.
- Several prizes are distributed on Saturday.  
             There are several prizes distributed on Saturday.
- Some children have been playing in the yard.  
             There have been some children playing in the yard.
- A new house is being built next door.  
             There is a new house being built next door.
- Few students are entirely without means of support.  
             There are few students entirely without means of support.
- A hatless stranger appeared.  
             There appeared a hatless stranger.
- A solution to this problem may not exist.  
             There may not exist a solution to this problem.

This rule moves the subject NP to a position after the first be in the following verb phrase, provided no non-auxiliary verb intervenes, and provided that the subject NP which is moved has an indefinite determiner, as in (18). The vacated subject NP position is filled with the morpheme there, which other transformations treat as an NP.\*

---

\* The operation of this rule when the main verb is occur, appear, exist, etc., is discussed in section II.7.

Morris Halle (personal communication) has suggested to me that there

- (19) I didn't assume there to be any reason for this.  
Harry didn't want there to be any trouble.

We can assume that two processes are involved; the first, which we can more appropriately call indefinite subject movement, moves the subject NP out of the subject position, and the second, there insertion proper, fills this empty NP with the morpheme there. Probably the feature of indefiniteness is retained on the empty subject NP, which causes there rather than it to be inserted in English, but this is not of importance here.

Our particular interest in this section is to show that the NP movement rule, indefinite subject movement, is structure-preserving. Three arguments to this effect follow.

First, we note that be has an obligatory complement, just like the prepositions for, with, agentive by, etc. mentioned in the preceding section.

- (20) \*Some of the workmen were.  
\*Only Bill and John will be.  
\*Some people who like beer are.

However, no one kind of constituent is obligatory after be. Either a predicate nominal (NP) or a predicate adjective (AP) or a prepositional phrase may be chosen, with an S possibly substituting for the predicate nominal NP. We will see how an S substitutes for a subject or object NP

---

(footnote cont.)

may be no definiteness restriction on the subject movement part of the rule, and that it rather than there is inserted into subject position when a definite deep subject is moved, yielding sentences like:

It's Bill in the back seat.

It's that old friend of mine coming down the street.

It was a vacuum cleaner making that noise.

It's (cf. \*are) my friends outside.

in Chapter III. (There is a sense of be meaning exist which sometimes occurs without a complement, but such cases are marginal.)

In the discussion of the passive we saw how an empty node in deep structure could fulfill an obligatory sub-categorization condition (on by) provided that this node be filled at some stage of the transformational derivation. Thus, by had an empty object NP in deep structure, which had to be filled by a transformation. With reference to be, this means that an empty deep structure predicate nominal NP which is filled by indefinite subject movement should fulfill the condition that be have a complement. If indefinite subject movement is not formulated as a (structure-preserving) substitution of subject NP for the predicate nominal NP, a very awkward set of ad hoc conditions results: indefinite subject movement is obligatory instead of optional just in case nothing follows be and be can be missing a deep structure complement just in case it has an indefinite subject. And in fact, just these conditions hold:

- (21) \*Lots of people who don't like beer are.  
       There are lots of people who don't like beer.
- \*One person with a hat on was.  
       There was one person with a hat on.

Thus, we see that the structure-preserving formulation removes a cumbersome ad hoc restriction from the indefinite subject movement rule.

A second argument for the structure-preserving nature of indefinite subject movement can be made by examining the use of be as a modal (M) either of expectation or necessity or of futurity (in connection with going or "gonna"). These uses, exemplified in (22), are modal uses because they do not occur inside VP's (i.e., after other modals or in infinitives, gerunds, etc.; I justify analyzing M as a sister to VP in Chapter V).

- (22) A demonstration is going to be held at six.  
 \*A demonstration may be going to be held at six.  
 \*They expect the demonstration to be going to be held at six.
- Three senators are to be here for the conference.  
 \*The senators' being to be here surprises me.
- You are to read one book every evening.  
 \*They insisted on your being to read one book every evening.

If indefinite subject movement is not structure-preserving, a simple statement of it without ad hoc conditions concerning modals would place the subject NP after the first occurrence of be, as in (23).

- (23) There is a new house being built next door.  
 \*There is being a new house built next door.
- There were only three students being obnoxious.  
 \*There were being only three students obnoxious.

But when the first be is an M, such a statement of the rule yields the wrong results:

- (24) \*There is a demonstration going to be held at six.  
 \*There are three senators to be here for the conference.

Rather, the indefinite subject movement moves the subject NP to a position after the first be under the VP:

- (25) There is going to be a demonstration held at six.  
 There are to be three senators here for the conference.

The structure-preserving constraint not only accounts for this but explains it, in the sense that another formulation of indefinite subject movement (for English) which would place the subject NP between M and V when M is be would be impossible, since the phrase structure rules do not provide an empty NP in that position. Thus, the structure-



preserving constraint removes a second ad hoc condition on indefinite subject movement.

As a preliminary to a third argument that indefinite subject movement is a structure-preserving rule, I digress to examine how predicate nominals and predicate adjectives are generated by the phrase structure rules. I will refer to both predicate adjectives and predicate nominals as predicate attributes.

Semantically, a predicate attribute modifies the subject NP, whereas a direct object NP or an adverbial AP complete the meaning of the verb without standing in a direct relation with the subject NP. Examples of predicate attributes are underlined in (26).

- (26)      The boy was a good swimmer.  
           Some teenagers are very submissive.  
           Three of the managers became vice-presidents.  
           John became violently ill.  
           One boy seemed too polite.  
           He seems the perfect choice.  
           The girl looked happy.  
           He remained the only Latin teacher in the school.

A variety of syntactic facts correlate with the difference in grammatical relations between predicate attributes and verb complements.

- (i) In many languages with declined adjectives, the head of a predicate attribute AP (but not an adverbial AP) agrees with the subject NP in number, case, and grammatical gender. (ii) A predicate attribute NP agrees with the subject NP in number and, in many languages with case systems, in case. (iii) In English, any AP immediately dominated by VP or S is marked with an ly suffix, the exceptions (besides a few lexical items like fast and hard) being just the predicate attribute AP's. (iv) The NP preposing (passive) rule and the rule which moves

NP's from complements of certain adjectives like easy and difficult into the subject NP's of these adjectives does not apply to predicate attribute NP's. (v) There are restrictions on when wh fronting can move a predicate attribute NP in relative clauses.

It is clear, then, that predicate attribute nodes must be structurally differentiated from complement nodes. I introduce a feature +PRED for this purpose and assume that the rules that account for (i) through (v) above involve the feature +PRED. The VP expansion rule is then (27).\*

$$(27) \quad VP \rightarrow V - \left( \begin{array}{c} NP \\ +PRED \\ \{ NP \} \\ \{ AP \} \end{array} \right) - (PP)^* - (S)$$

The appearance of a feature (+PRED) in a phrase structure rule need not be considered formally unusual; compare the rules for expanding NP in section II.6.

It is clear from (27) that indefinite subject movement should not apply in sentences with deep structure predicate attributes if this rule is structure-preserving. (If predicate attributes are present in deep structure, no empty node which the subject NP can move

---

\* In view of sentences like "Harry made the other men furious" and "I found the movie quite boring," it is possible that (27) should be revised to allow some verbs to have both an object NP and a predicate attribute, which in such cases modifies the object. If this is the case, then we must make the stipulation that empty nodes in deep structure are always subject to sub-categorization conditions in order to exclude the ungrammatical sentences of (28) on principled grounds. This would have undesirable consequences in formulating certain other structure-preserving rules, so I reject this alternative here. Further study of the role of sub-categorization features in the structure-preserving framework is certainly warranted, even if this framework is essentially correct.

onto is generable by (27).) In fact, this is the case:

(28)     Some graduate students are union members.  
\*There are some graduate students union members.

      Few taxi drivers are too rich.  
\*There are few taxi drivers too rich.

      One man was a pharmacist.  
\*There was one man a pharmacist.

      Many home owners are angry.  
\*There are many home owners angry.

      A few photographs were too dark.  
\*There were a few photographs too dark.

      In this course, three books are important.  
\*In this course, there are three books important.

There are a few words such as available, absent, and missing which are sometimes used as adjectives and which can appear after predicate nominals in sentences akin to those in (28). These cases are discussed below, and shown not to be counterexamples to the claim that indefinite subject movement doesn't apply in sentences which have predicate adjectives.

In some dialects, the sentences of (29) are acceptable, though the class of adjectives which can appear in such sentences is restricted.

(I do not always find these sentences completely acceptable.)

(29)     ?There might be some students hungry.  
          There are probably a dozen people drunk.  
          ?There was a man very sick.

I have no explanation at present for why these sentences should be acceptable. (If the adjectives in (29) could be shown to be inside the predicate nominal NP's as remnants of reduced relative clauses, these sentences would not be a problem for the analysis proposed here.)

We must now determine why indefinite subject movement is optional when the deep structure complement of be is a PP; cf. (18). Two explanations are possible.

In one view, a sentence like "John was a doctor in Denver" exhibits an NP-PP combination in the complement of be in deep structure, so a structure-preserving rule could yield this same combination, as in "There were some doctors in Denver."

In a second view, the deep structure complement to be may be a predicate attribute or a PP, but not both. In this case, the locative PP must be outside the lowest VP in "John was a doctor in Denver," but inside the lowest VP in "Some doctors were in Denver" (and similarly in "There were some doctors in Denver." However, if we assume that empty nodes in deep structure need not fulfill sub-categorization conditions but only the requirements of the phrase structure rules,\* then (27) provides an empty NP for indefinite subject movement when the deep structure complement of be is a PP but not when it is a predicate attribute (i.e., NP-PRED sequences are excluded.) This is the position I will follow in this study.

This excludes in turn the possibility, mentioned in a previous footnote, that sentences like "Harry made the other men furious" or "I found the movie quite boring" are generated directly by the VP expansion rule (rather than by a transformational deletion of be.)

Some apparent counter-examples to the claim that indefinite subject

---

\* This is actually a rather natural assumption. Morris Halle has pointed out to me that it would be difficult to motivate a transformational rule on syntactic grounds if it were structure-preserving and if its outputs were subject to all deep structure sub-categorization conditions.

movement does not take place in sentences with deep structure predicate adjective AP's are given in (30).

- (30)        There are quite a few students missing.  
               There were three doctors available.  
               There are at least three students absent.

Available, missing, and absent appear at first to be predicate attributes. However, while these three words sometimes function as adjectives, it is also true that they function as adverbs of place (i.e., as intransitive prepositions), analogous to here, inside, around, etc. Such usage can be seen clearly in noun phrases in which all these adverbs occur after head nouns; if they were ordinary adjectives, they could only appear before the nouns in question.

- (31)        The people missing bought up all the seats inside.  
               We will take any seat available at this late date.  
               They told the people here that the seats available are cheap.  
               All the books around show how the people absent feel.

I therefore assume that available, missing, and absent in (30) are adverbs (intransitive prepositions) in deep structure, and not predicate adjectives at all. As we have seen above, predicate attributes can occur before adverbial PP's after be, so the sentences of (30) are to be expected.

II.2.2    The Status of the Auxiliary Be    I have presented three arguments that indefinite subject movement is a structure-preserving substitution rule. This result in turn sheds light on the question of whether the participles which follow be are constituents or not.

In this discussion, I will designate the pre-terminal symbol dominating be by  $\left[ \begin{array}{c} V \\ AUX \end{array} \right]$  (and hence any phrase node of which be is the

head by VP.) AUX is an ad hoc feature which will be used in section V.1 to state the rule that distinguishes be from other verbs. However, we could as well replace  $\left[ \begin{smallmatrix} V \\ \text{AUX} \end{smallmatrix} \right]$  with an entirely different category symbol, say BE, as far as the argument in this section is concerned.

The presence of one ad hoc feature in the auxiliary analysis of this section is paralleled in the auxiliary analysis given in Chomsky (1957). Chomsky used the ad hoc feature or node "small v" to designate the class of elements which take the verbal affixes (ed, s/ø, en, and ing) in stating the "affix movement rule."

The following argument that the participles following be are constituents rests on the assumption that both be's in (32) have the same source (i.e., that they both are from the be-ing combination characteristic of the English progressive construction.)

- (32)        Some children may be riding horses.  
              There may be some children riding horses.

If this is incorrect, which would mean that the analysis of indefinite subject movement of section II.2.1 is incorrect, the following argument cannot be made.

Let us now construct two possible deep structures for the first example in (32). In (33), we assume that the present participle after be is not a constituent, and that be is an auxiliary particle modifying the main verb. (I am not concerned here with the placement of ing and en.)

(33)

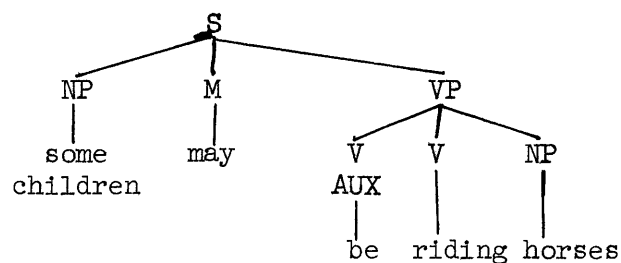

In (34), we assume that the present participle after be is a constituent.

(34)

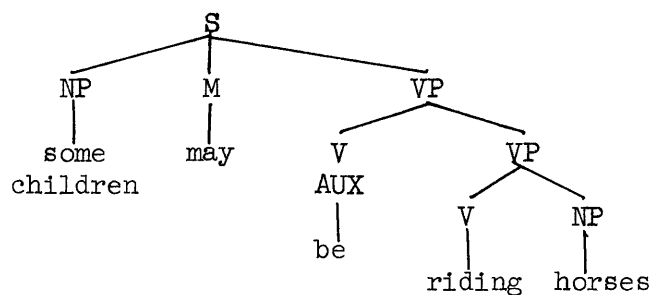

Indefinite subject movement moves the subject NP to a position after the first non-modal be. I showed in section II.2.1 that this rule should be formulated as a structure-preserving rule. Therefore, the deep structure of the second example in (32) would be (35) if (33) is correct, and (36) if (34) is correct.

(35)

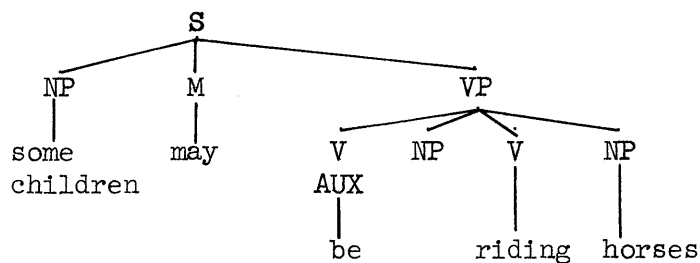

(36)

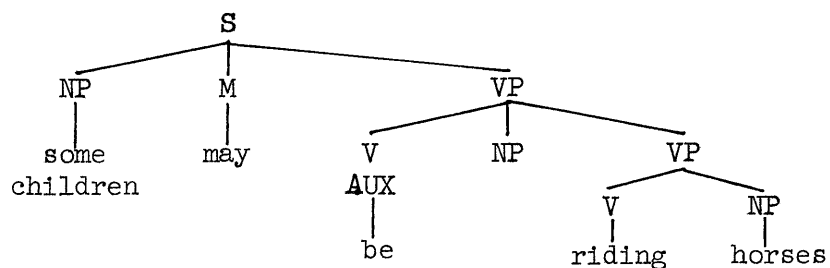

We can reject (35) (and hence (33), which differs from (35) only by an empty node) as a possible deep structure, because the phrase rule for expanding VP does not generate a PRED node or an NP node of any type before the main verb (V) node. Thus, if we accept the formulation of indefinite subject movement given in section II.2.1, the underlying structure of a progressive (or of a passive, by the same argument) is as in (34).

By accepting the structure (36), I do not mean to imply that the combination be-NP-VP occurs in deep structure with both NP and VP non-empty. But if we assume (cf. section II.2.1) that empty nodes need not fulfill sub-categorization conditions, then the VP expansion rule (27) is the only factor which chooses between (35) and (36). Since V-NP-VP is a possible VP expansion, but V-NP-V-NP is not, I chose (36) over (35).

There is some question as to the ultimate source of the lowest VP in (34) and (36). However, this is the same question that must be answered concerning the VP complements of verbs like begin, finish, tend, hasten, hesitate, etc. The subject NP's of the complements to these verbs (or to the progressive be) never appears between the verb in question and the complement, so it is not known whether the VP's should be generated directly (as complements to verbs) by the phrase structure rules, or whether they are remnants of deep structure S's whose subject NP's have either been raised or deleted.

The structure of the progressive construction arrived at here (34) is similar to the structure of complements of verbs of temporal aspect (begin, start, continue, commence, go on, keep, keep on, resume, finish, stop, etc.) These are the only intransitive English verbs which have



VP complements introduced by ing which are not NP's. Rosenbaum (1967) argued these complements were not NP's because they do not move to subject position by the NP preposing (passive) rule. They also do not appear in focus position in cleft sentences.

- (37) \*It was typing the letter that John resumed.  
\*Typing the letter was resumed by John.
- (38) John began appreciating music at Harvard.  
\*It was appreciating music that John began at Harvard.  
\*Appreciating music was begun by John at Harvard.

(There is a sense of begin, meaning "initiate," which takes an NP clause object introduced by ing, and this is the only sense of begin when it appears in passive and cleft sentences. This interpretation of the VP complement in (38) is marginal.)

The same prohibitions apply to the complements of the progressive and passive be, as expected.

- (39) \*It was riding horses that the children were.  
\*It was found by the minister that the children were.

The structure of the complements of verbs of temporal aspect is then as in (40); compare this to (34).

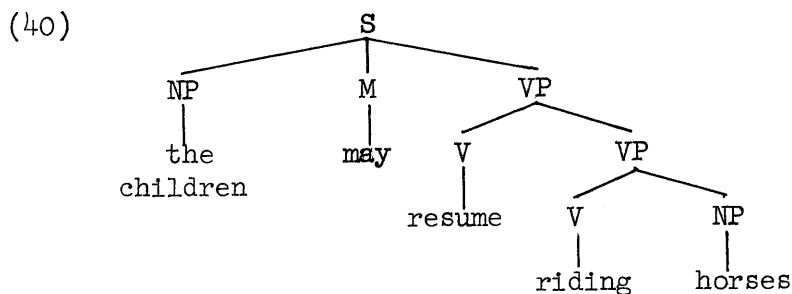

For purposes of exposition, I will assume that the participle after have (which expresses the perfect) is also a constituent, in the same way

that the participles after be are constituents; however, I have no independent evidence for this assumption.

The following questions then arise: why does the auxiliary have never follow itself or the progressive be, and why does the progressive be never follow itself? (That is, what accounts for the ordering of the auxiliary verbs?)

Concerning the auxiliary have, it is a fact (which I will not try to explain here) that clause complements which may not have expressed subjects in surface structure never begin with the perfective auxiliary have. (These include the complements to verbs like try, like persuade, like prevail on, and like begin discussed in Rosenbaum (1967).)

- (41)
- |        |  |  |
|--------|--|--|
| *John  | $\left\{ \begin{array}{l} \text{began} \\ \text{continued} \\ \text{resumed} \\ \text{stopped} \\ \text{went on} \end{array} \right\}$ | $\left\{ \begin{array}{l} \text{having said something important.} \\ \text{having eaten dinner.} \\ \text{having been examined.} \end{array} \right\}$ |
| *Harry | $\left\{ \begin{array}{l} \text{tried} \\ \text{tended} \\ \text{hesitated} \\ \text{started} \\ \text{went on} \end{array} \right\}$  | $\left\{ \begin{array}{l} \text{to have written a letter.} \\ \text{to have overeaten.} \\ \text{to have spoken on politics.} \end{array} \right\}$    |

Since the complements to the perfective have and the progressive be are in this class (they never have expressed subjects in surface structure), I will assume that they are subject to this more general restriction also.

- (42)
- |                 |  |
|-----------------|--|
| *John was       | $\left\{ \begin{array}{l} \text{having said something important.} \\ \text{having eaten dinner.} \\ \text{having been examined.} \end{array} \right\}$ |
| *John will have | $\left\{ \begin{array}{l} \text{had eaten dinner.} \\ \text{had overeaten.} \\ \text{had written a letter.} \end{array} \right\}$                      |

The fact that the progressive be does not follow itself can be attributed to the general prohibition of the sequence be-ing-V-ing in surface structure.

- (43) \*John regretted being eating when Mary arrived.  
 \*After being singing for so long, I'd like to eat.  
 \*The people being telling the story are tired.  
 \*John, being studying French, would be the person to ask.  
 \*John was being studying French.  
 \*The people were being telling a long story.

Thus, the ordering restrictions on the auxiliaries can be accounted for by general principles, even though they are not sister constituents, as in Chomsky (1957).

Another objection that might be made to treating the gerund complements of be and of verbs like finish in the same way (as VP sister constituents to the pre-terminal symbols dominating finish and be) is that it would not account for the difference between (44) and (45). In (44) the active-passive pair are paraphrases, while in (45) the active has a sense that the passive lacks, in which the subject NP is an agent.

- (44) John was playing my record.  
 My record was being played by John.
- (45) John finished playing my record.  
 ?My record finished being played by John.

However, when we assumed in Chapter I that a single **AUX** constituent does not dominate all auxiliary verbs in a given S, an implicit consequence was that the passive rule (NP preposing) must be stated so that it moves the object of a verb only if no V intervenes between the verb and the subject NP position. If we write  $\left[ \begin{array}{c} V \\ \text{AUX} \end{array} \right]$  as BE, or if we equivalently change the condition on the passive that it not apply if any verb with

the feature  $\neg$ AUX so intervenes, then NP preposing will not apply to the string underlying the active in (45), although it will apply to the string underlying the active in (44).

In summary, the conclusion of this section is a limited one: a structure-preserving indefinite subject movement rule implies that the progressive and passive participles after be are constituents.

II.3 Dative Movement Rules In the theory of movement rules I am trying to construct in this paper, any movement rule which applies freely in embedded sentences must either be a structure-preserving rule or a (yet to be defined) minor movement rule. I think it is possible that all phrase node movement rules (in particular, all NP movement rules) are structure-preserving, in which case the dative movement rules provide an important indication of what types of structure-preserving rules are allowed, as we will see. On the other hand, the dative movement rules fit quite naturally into the highly restricted class of minor movement rules to be investigated in Chapter V, so we cannot be sure if we should require that all phrase node movement rules be structure-preserving without exception.

The dative movement rules in English relate pairs of sentences such as the following:

- (46) The paper which I wrote John a letter on was old.  
 The paper which I wrote a letter to John on was old.
- To refuse visitors permission to enter is bad enough.  
 To refuse permission to enter to visitors is bad enough.
- John's parents are happy because he carved them a statue.  
 John's parents are happy because he carved a statue for them.
- They were talking about building the residents a park.  
 They were talking about building a park for the residents.

Thus, a dative movement rule has two functions: (i) it deletes a preposition (to or for) and (ii) it reverses the order of two postverbal NP's.\*

The deletion of a preposition is not unparalleled in English grammar, and it is formally distinct from the operation which reverses the order of the two NP's. Another example of a preposition deletion rule in English is the optional deletion of for and on in certain adverbial expressions of time.

- (47) John has been working on this table (for) three hours.  
 I'm going to step outside (for) just a moment.  
 The guests registered here (~~on~~) October first.  
 You should pay your bill (on) the last day of the month.

The deletion of a preposition before adverbs of time is obligatory in certain cases:

---

\* Fillmore (1965) proposed that English has two dative movement rules because the indirect objects derived from deep structure to phrases can undergo the NP preposing (passive) rule, while those derived from deep structure for phrases cannot. That is, most speakers of American English find the sentences of the first group below completely acceptable and those of the second group somewhat unacceptable.

The visitors must have been refused permission.  
 The children were told a bedtime story.  
 A few natives are being taught Spanish by the volunteer.  
 John has just been promised a large refund.

- \*The visitors must have been found some food.
- \*His parents were carved a statue.
- \*Mary is being built a table by John.
- \*The guests have just been roasted a duck.

This discrepancy can be explained by assuming that the objects of to phrases but not those of for phrases are moved in front of the direct object (optionally) before the NP preposing rule applies, and are hence subject to being preposed. That is, ordering to dative movement before NP preposing and for dative movement after it accounts for the difference between the two groups of sentences given above.

What is said in the text is independent of whether Fillmore's suggestion is correct or not.

- (48) He paid the rent (\*on) last Saturday.  
 They deliver the paper at noon (\*on) every weekday.  
 I'll finish my dessert later (\*in) this afternoon.  
 Cf. I'll finish my dessert later in the afternoon.

Postulating a P deletion rule for time adverbial NP's means that the phrase structure rule expanding NP need only allow PP's and S's (and not NP's) after the head noun. That is, the underlined NP's in (49) can be derived from deep structure PP's.

- (49) The discussion last Saturday disturbed him.  
 They predict a big storm this afternoon.  
 The traffic jam every weekday makes city life less desirable.

The deletion of to and for in dative movement is formally similar to the deletion of on, for, or in in time adverbials, and is a part of any formulation of dative movement rules. On the other hand, the reversing of order of the two post-verbal NP's which result from this P deletion could logically be formulated in various ways: the second NP could move over the first, the first over the second, or the two could exchange positions. The first two possibilities are not structure-preserving (without ad hoc elaborations), as illustrated in (50).

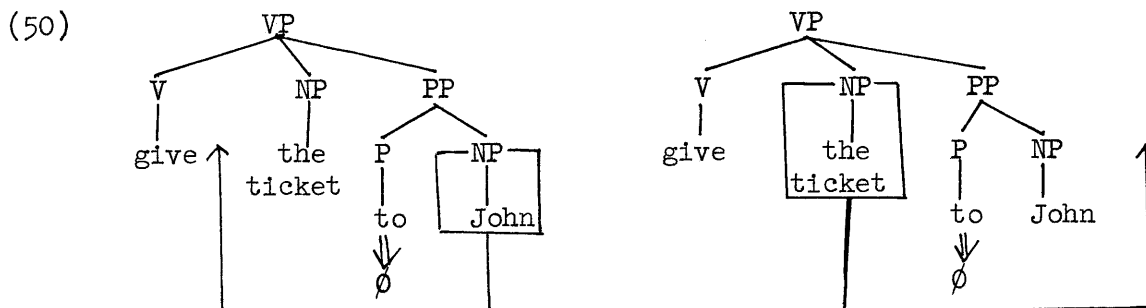

On the other hand, a rule interchanging the position of two constituents of the same category is always structure-preserving, in the sense that

both constituents are moved into positions where the phrase structure rules allow such constituents.

More precisely, recall that in section II.1 the general form of structure-preserving rules was as in (51):

$$\begin{array}{lcl}
 (51) & X - B - Y - B - Z & \Rightarrow & 1 - 4 - 3 - \left. \begin{array}{c} \emptyset \\ \text{or} \\ +\text{PRO} \end{array} \right\} - 5 & \text{(movement to left)} \\
 & X - B - \bar{Y} - B - Z & \Rightarrow & 1 - \left. \begin{array}{c} \emptyset \\ \text{or} \\ +\text{PRO} \end{array} \right\} - 3 - 2 - 5 & \text{(movement to right)}
 \end{array}$$

We can formulate the permutation of dative movement as a structure-preserving rule if we allow the right-hand side of (51) to also have the form "1 - 4 - 3 - 2 - 5" (permutation). Such a formulation of dative movement makes crucial use of the fact that dative movement reverses the order of two constituents of the same category (given the deletion of the preposition as a separate part of the rule). In this view, to dative movement has the form (52).

$$(52) \quad X - \text{NP} - \underline{\text{to}} - \text{NP} - Z \Rightarrow 1 - 4 - \emptyset - 2 - 5, \text{ where } X \text{ dominates } Y+V.$$

(There are other restrictions on (52); the head of VP must be in a certain class, the second NP in most cases must be +ANIMATE, etc.)

According to (52), the derived structure of sentences like (53) is that of (54).\*

---

\* For some verbs, like give, bring, deny, sell, etc., to dative movement doesn't apply if there is no (non-empty) direct object NP: \*"John gave Bill," \*"We read Bill", etc. For others, like pay, teach, tell, etc., to dative movement must apply if a direct object NP is missing: "We paid (\*to) the landlord," "John told (\*to) his brother," "He teaches (\*to) children," etc. Cf. also "He is writing (to) the president."

(53) John { gave  
taught  
paid  
read  
promised } Bill { a letter  
French  
the rent  
the verdict  
a book } .

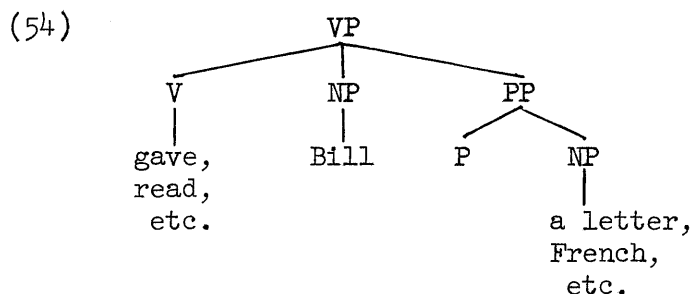

There is evidence to confirm the claim that the derived structure of sentences like (53) have an empty P, as in (54). This evidence is the existence in English of a class of verbs which, like give, deny, sell, pay, teach, etc., have complements in which to dative movement applies, and which furthermore require that a preposition be inserted into the empty P provided for by the dative movement rule. Such verbs are supply, furnish, provide, and credit, which appear in examples like (55).

(55) They credited Smith (with this discovery).  
They credited this discovery to Smith.

The company furnishes us with a car.  
The company furnishes a car (to us).

France used to supply Israel (with jets).  
France used to supply jets (to Israel).

Verbs like supply can be analyzed like other verbs with indirect objects, with the added stipulation that the preposition with be inserted into the empty P of (54), as in (56). This "use" of the empty P in (54) accounts in simple fashion for a paradigm like (55) which differs from the ordinary indirect object paradigm, and hence justifies in some measure the derived structure that a structure-preserving formulation



of dative movement assigns to sentences with indirect objects.

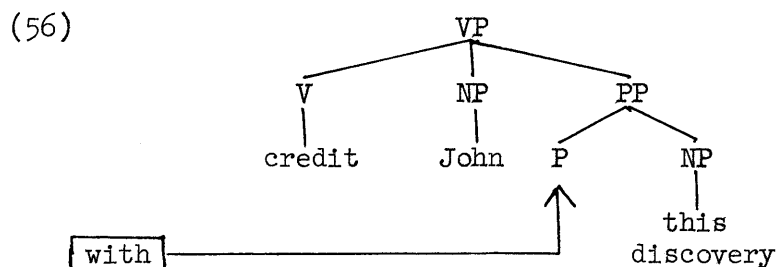

One might possibly wish to exclude permutations of the type given in (52), allowing only structure-preserving movement rules of the kind given in (51). This will gain plausibility in Chapter V, when we investigate a highly restricted class of permissible non-structure-preserving rules which can apply in embedded sentences, the "minor movement rules." Rules of this class have as their principal characteristic that a single constituent is moved over a contiguous single constituent. If such rules can also move phrase nodes, the dative movement rules can be considered as members of this class. I return to this possible alternative to (52) in Chapter V. For the moment, I will consider dative movement as a structure-preserving interchange of NP's, as in (52), and will retain the stronger hypothesis that phrase node movement rules in embedded sentences must always be structure-preserving.

II.4 It Replacement In Chapter III, I will argue that no S complements such as those underlined in (57) at the end of the constituents NP, AP, and VP are themselves NP's.

- (57) It  $\left\{ \begin{array}{l} \text{appears} \\ \text{happens} \end{array} \right\}$  that this coat is waterproof.  
 It was  $\left\{ \begin{array}{l} \text{likely} \\ \text{a sure bet} \end{array} \right\}$  that John owned a house.  
 She  $\left\{ \begin{array}{l} \text{believes} \\ \text{considers} \end{array} \right\}$  that Bill has stayed too long.  
 We can  $\left\{ \begin{array}{l} \text{depend} \\ \text{count} \end{array} \right\}$  on it that their paper has printing errors.  
 It is  $\left\{ \begin{array}{l} \text{said} \\ \text{thought} \end{array} \right\}$  that this inflation is due to productivity.

The trees corresponding to the examples of (57) are then roughly those of (58) - (62). (TENSE is omitted.)

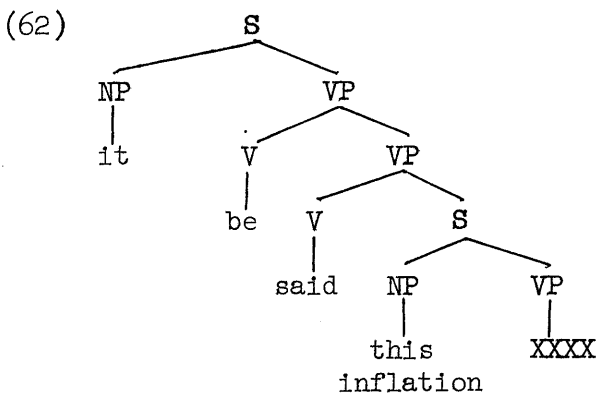
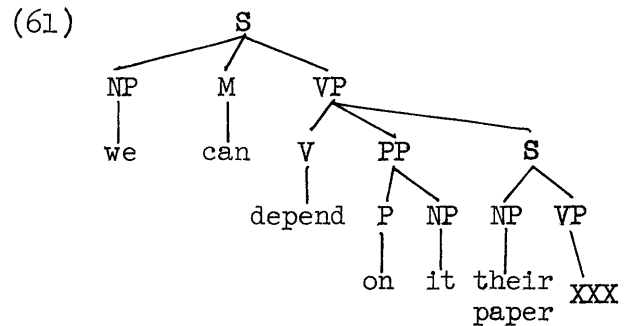
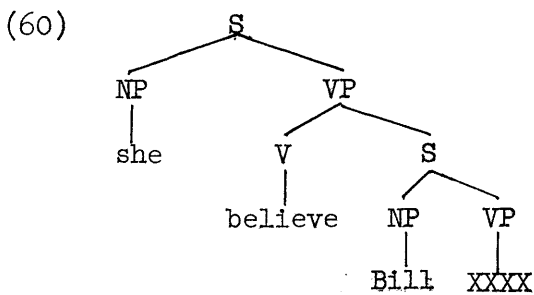
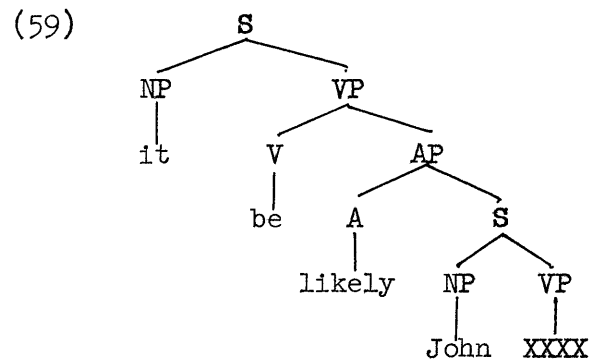
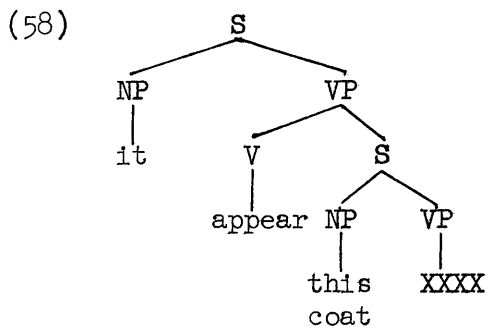

In the framework of Rosenbaum (1967), the underlying structure corresponding to (60) contains an it which is deleted in surface structure. If such an it is present in deep structure, (60) should be modified to (63), in the framework to be developed in Chapter III.

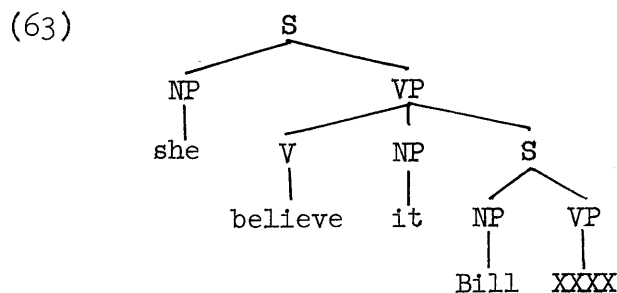

The sentences of (57) are paraphrased by those of (64).

- (64) This coat {appears  
happens} to be waterproof.  
 John was {likely  
a sure bet} to own a house.  
 She {believes  
considers} Bill to have stayed too long.  
 We can {depend  
count} on their paper to have printing errors.  
 This inflation is {said  
thought} to be due to high productivity.

Rosenbaum (1967) argues that the sentences of (64) should be derived from those of (57); to accomplish this, he introduced a rule of it replacement whereby the subject NP's of the embedded S's in (57) are substituted for the it's in higher S's.

We can easily adapt Rosenbaum's formulation of it replacement (which depends on his assumptions about the deep structure of sentence and infinitive complements) to the results of Chapter III. Given the underlying structures (58) - (63), it replacement becomes a structure-preserving NP movement rule which has the effects indicated in (65).

(65)

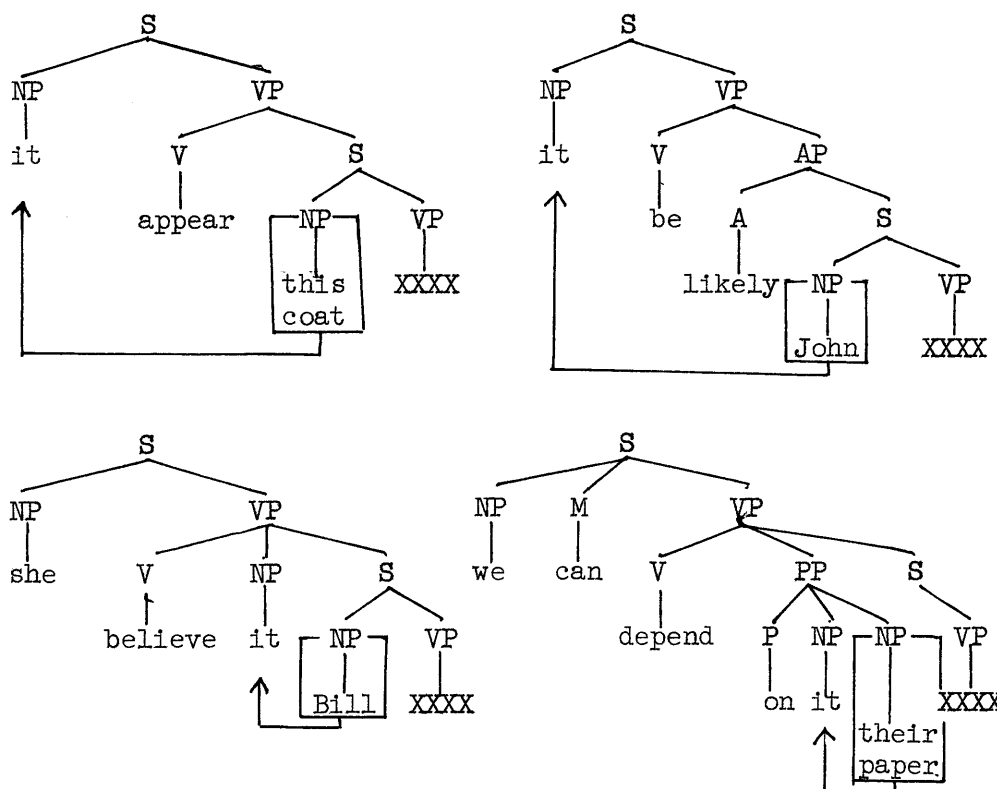

Whether this rule which moves the subject NP of embedded sentences replaces NP's which dominate it (deleting it in the process) or empty NP's\* is not of direct interest here. As far as the structure-preserving hypothesis is concerned, the important fact is that Rosenbaum's it replacement rule (or the appropriate modification of it) moves NP's into positions where the phrase structure rules generate NP's: subject position, direct object position, and prepositional object position.

Another it replacement rule relates the pairs of sentences in (66). This rule differs from the previous it replacement rule, which is sometimes alternatively called "subject raising," in that it removes NP's from the VP complements of embedded sentences rather than from

---

\* It may be that some or all of the it's in (58) - (63) are transformationally inserted, and that the NP's dominating them are still empty when they are replaced by the subject NP of the embedded S.

subject position. We might call it, rather imprecisely, "object raising."

- (66) It is easy to lift John onto the horse.  
 John is easy to lift onto the horse.
- It is hard to lift John onto the horse.  
 The horse is hard to lift John onto.
- It would be a lot of fun to talk to a movie star.  
 A movie star would be a lot of fun to talk to.

This rule is also structure-preserving, as is shown in (67). \*

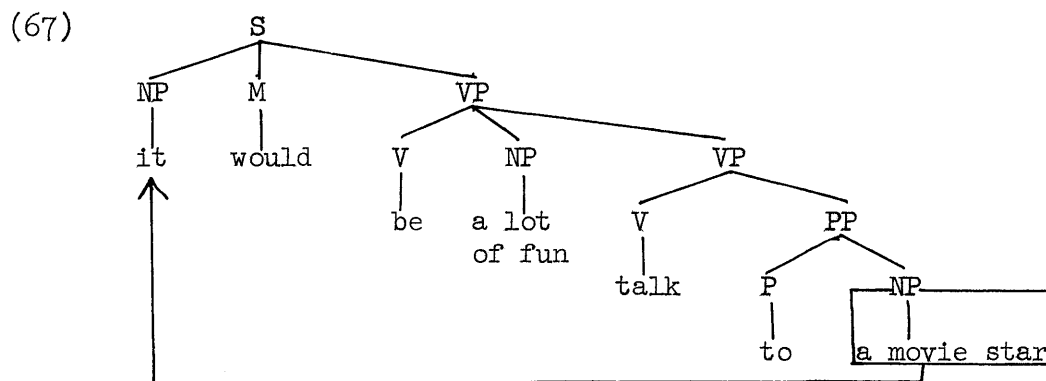

The structure-preserving constraint explains why English does not have rules which move NP's out of complement S's into a non-NP position, such as, say, the beginning of the VP which is a sister to M, as in (68).

- (68) \*It may this coat appear to be waterproof.  
 \*The fact that it will John be likely to be away disturbs me.  
 \*The man who it is Bill believed to dislike is here.  
 \*It has this task been easy to finish.

---

\* By citing any movement rules that have been discussed in the literature of generative grammar, I do not mean to imply that I am arguing that they should not or could not be replaced with another analysis which might use, say, a deletion rule. I simply mean to point out that, if a movement rule is involved, the rule is (i) structure-preserving, (ii) a minor movement rule, or (iii) a root transformation, as the case may be.

II.5 Conjunct Movement Lakoff and Peters (1966) have proposed that the second sentences in the pairs of (69) be derived from the first sentences by a rule called "conjunct movement". There are arguments against this rule given by Dougherty (1968) and Perlmutter (1968). I do not mean to counter these arguments; I wish only to discuss the rule in light of the structure-preserving constraint in case that, given some revision in the theory of grammar, these criticisms can be answered.

(69) Bill and Mary walked downtown. ("together", not "both" sense)  
Bill walked downtown with Mary.

My brother and his friends are reading Marx.  
My brother is reading Marx with his friends.

Sam and Mary and Sue and Fred are co-operating.  
Sam and Mary are co-operating with Sue and Fred.

Beer and chocolate don't mix well.  
Beer doesn't mix well with chocolate.

The formal effect of conjunct movement described by Lakoff and Peters can be trivially modified in the structure-preserving framework, so that this rule fills an empty deep structure object NP of with, as in (70).

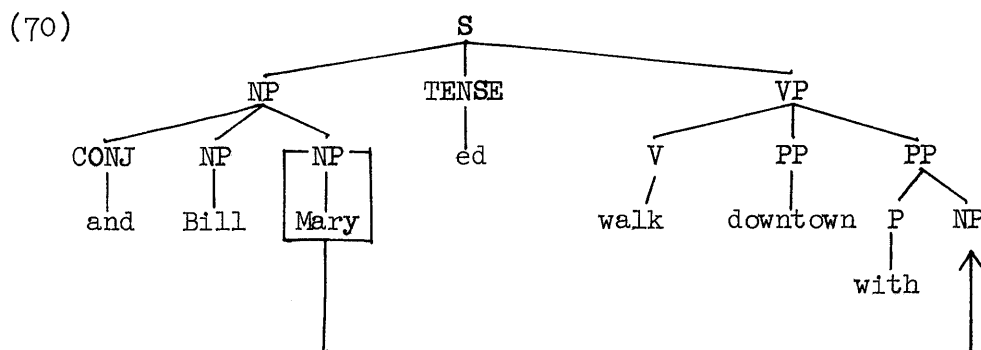

## II.6 The Possessive Transformation

II.6.1 The Phrase Structure Rule for Expanding NP As a preliminary to the discussion in this section, a formulation of the NP expansion rule is in order.

Perlmutter (1968b) has argued persuasively that the indefinite article a(n) is not a determiner (DET) in the class of morphemes containing the, this, that, every, each, etc., but that it is rather a reduced form of the numeral (NUM) one. Further, he argues that some numeral is always present with a singular count noun in deep structures, and that unstressed one (i.e., a(n)) is deleted after a preceding determiner, such as a possessive NP or the definite article, only at a relatively superficial level. (If the plural morpheme is taken as an instance of NUM, then NUM is obligatorily present in deep structure with all count nouns.)

Let NUM then be the pre-terminal symbol dominating any cardinal numeral including a(n), and let DET be the class of morphemes within the NP which can immediately precede NUM: the, this, that, NP's, every, each, which, any, some, no, what, such. (Compare what a man, such a man). NUM can be extended to include other elements which can follow DET and/or which never immediately precede or follow a numeral: many, few, much, little, several (a few and a little?). All and both can occur before NUM and before certain elements of DET also, namely, NP-'s, the, this, that, and such; we need not decide here whether they are dominated by DET or not.

With the two categories DET and NUM defined, we can write a tentative phrase structure rule for expanding NP's:

$$(71) \quad NP \rightarrow \begin{pmatrix} \text{DET} \\ \text{(NP)} \end{pmatrix} - (\text{NUM}) - N - (\text{PP})^* - (\text{S})$$

Chomsky (1970) has given two arguments that the phrase structure rules should generate NP's in the DET position, according to a rule roughly like (71). (However all and both are analyzed, this NP can appear when they are present as well as when they are not.) First, he argues that noun phrases such as those underlined in (72) cannot be derived from the corresponding sentences in (73) without reducing the notion of "grammatical transformation" to vacuity.

- (72) The enemy's destruction of the city was complete.  
The destruction of the city by the enemy was complete.  
The city's destruction by the enemy was complete.
- The corn's growth was amazing.  
The growth of the corn was amazing.
- John's stupidity exceeded only his desire for books.  
The stupidity of John exceeded only his desire for books.
- He didn't measure the table's length.  
 He didn't measure the length of the table.
- (73) The enemy destroyed the city.  
 The corn grew.  
 John was stupid.  
 The table was long.

Given this, if we want to have the same order of elements and grammatical relations in the deep structures of the noun phrases of (72) as in the corresponding sentences of (73), we must generate "subject" NP's of noun phrases inside NP's by a rule like (71). (That is, the deep structure order of elements in (72) must be the enemy's destruction, the corn's growth, John's stupidity, the table's length, etc.)

Second, Chomsky points out that certain uses of possessive NP's (those followed by 's) such as those underlined in (74a) cannot be



plausibly derived from deep structures in which these NP's are not in the DET position. For example, the sentences of (74b) are not paraphrases of those in (74a).

- (74) (a) John's bad eyes are his greatest handicap.  
 Have you seen John's measles?  
 Bill doesn't like Mary's father.
- (b) \*The bad eyes of John are his greatest handicap.  
 \*Have you seen the measles of John?  
 \*Bill doesn't like the father of Mary.

In view of these arguments, I incorporate (71) into the grammar of English.

One further observation can be made about DET. Postal (1966) has argued that the personal pronouns I, we, you, he, they, etc., are forms of the definite article; if this is so, they are instances of DET in this analysis, according to the following paradigm: (All the combinations in (75a) can appear as NP's.)

(75a)	we three boys	we boys	we three	<u>we</u>
	you three boys	you boys	you three	<u>you</u>
	these three boys	these boys	these three	<u>these</u>
	those three boys	those boys	those three	<u>those</u>
	the three boys	the boys	the three	<u>they</u>

The wh (relative and interrogative) pronouns probably have a similar source under DET, according to the paradigm of (75b). (The apparent use of that as a relative pronoun will be taken up in Chapter IV.)

(75b)	which three boys	which boys	which three	<u>which</u>
	what three boys	what boys	what three	<u>who</u>
	what three lamps	what lamps	what three	<u>what</u> (interrogative use only)

Rule (71) does not permit an NP to immediately follow an N or a NUM

or a DET, which is the case in surface structures in English. The possibility of an NP following an N in deep structure will be discussed in the next section.

The asterisk after (PP) in (71) implies that the limitations on the number and order of post-nominal PP's are determined by the lexical properties of the head noun, and not by a general constraint on internal NP structure. (Of course, one could alternatively define this asterisk as, say, "three at most," rather than as "indefinitely many" if a principled reason to do so were found.) The (S) is the source for full sentence and infinitive complements to nouns. It cannot be used as a source for relative clauses, however, since the latter co-occur with clause complements to nouns. I leave open the question of a deep structure source for relative clauses. Perhaps, since more than one such clause can modify a single noun, a recursion-permitting rule such as  $NP \rightarrow NP - S$  is appropriate.

Several important noun phrase constructions have been omitted from consideration to avoid disagreement over what are here unessential matters and for the sake of simplicity in exposition. No stand is taken here on whether NP's like several of the boys have an embedded PP in them, although I will argue in Chapter V that they do. Ordinal numerals (first, second, etc.) and the similarly behaving superlatives (best, last, cleanest), which most often precede NUM, have been ignored. Only also belongs with this class (all the members of the class can take infinitive relative clauses); Perlmutter (1968b) derives the surface structure the one from the only. Also ignored are the "degree" words too, enough, very, as, so, how, rather, etc., and their accompanying S complements which can modify the quantity words few, many, little, and much as well

as the traditional class of descriptive adjectives. The comparative morphemes (more-less) and accompanying than complements are similarly excluded.

The last point about (71) concerns the recent speculation (Chomsky, 1970) that all the material to the right of the DET position may be a separate constituent, say NOM. The evidence for this should at least be mentioned. First, if the personal and relative pronouns are instances of DET, then "pronominalization" (of either type) could be stated as a deletion of NOM, and combined with the rule that produces the examples of (76).

(76)        Although I haven't seen John's yet, I think I'll buy this bike.  
              I want a car, but I don't want yours.

Second, the examples of (77) indicate that NOM as well as NP constituents may be conjoined. \*

(77)        The victims in this war and executioners in the next (are a  
              very resourceful race).  
              John's first long talk and last good one (was the one on  
              politics).

Third, the internal NP structure that NOM provides, shown in (78), makes the definition of "grammatical subject of" extendable from sentences (S) to noun phrases (NP).

---

\* The conjoined NOM's in (77) must have the same reference, but this would be predicted if the referential index of an NP were located in DET. This is at least superficially plausible, since DET elements (pronouns, demonstratives, wh words, etc.) seem most crucially involved in specifying co-reference.

(78)



In any case, it will be necessary to speak of the NP on the right-hand side of (71) as the "subject NP" of the NP which dominates DET, whatever the correct definition for this notion is in grammatical theory. For purposes of exposition in familiar terms, the node NOM will not be adopted here; nothing crucial in the formulation or defense of our hypothesis seems to depend on its existence or non-existence. It should be noted that the usual transformational statements of the passive rule in no way depend on the hierarchical structures displayed in (78); they depend only on the order of constituents and the condition that the lowest S or NP dominating all the affected constituents be the same.

#### II.6.2 A Comparison of NP Preposing and the Possessive Transformation

Consider now the "passive noun phrases" of (79). These noun phrases are paraphrases of the "active noun phrases" of (80) and the "mixed noun phrases" of (81).

(79) The city's destruction by the enemy.  
The offer's acceptance by John.  
John's arrest by the police.

(80) The enemy's destruction of the city.  
John's acceptance of the offer.  
The police's arrest of John.

(81) The destruction of the city by the enemy.  
The acceptance of the offer by John.  
The arrest of John by the police.

If we assume that the sentences in (79) - (81) are transformationally related, and if we assume that the deep structure order of the head and

its object should be the same as that in the corresponding active sentences (82), it would appear that the noun phrases of (79) are derived from the structures underlying the mixed noun phrases of (81), by some transformation which preposes (inside the NP) a deep structure object NP.

- (82)       The enemy destroyed the city.  
           John accepted the offer.  
           The police arrested John.

I assume that the of's following the head nouns in (80) and (81) are not present in deep structure; this allows us to enter noun-verb pairs such as destroy-destruction in the lexicon as both transitive (i.e., it isn't necessary to specify one as appearing before of). If a rule of of insertion follows the rule which derives (79) from (81), then this latter rule need not mention either of or P.

Given the rule (71) for expanding NP's, the derivation of (79) from the structures underlying (81) can be expressed by a structure-preserving rule having the effect shown in (83). (As just mentioned, of is not yet inserted when this rule applies.)

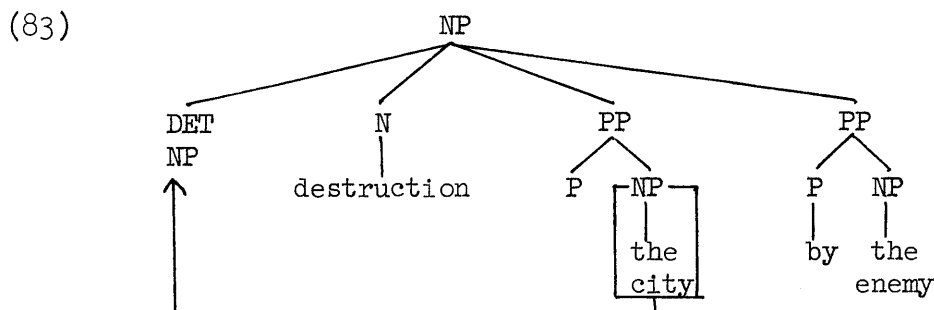

I now give several arguments that the rule operating in (83) is not the previously discussed NP preposing rule, but a separate structure-preserving rule we can call the "possessive transformation."

First, NP preposing moves an NP over a verb (or adjective) followed by a lexical preposition in many cases, but the rule operating in (83) never does. (No of follows the head noun in (82); in any case, NP preposing moves NP's over other prepositions besides of and these prepositions are retained in surface structure.)

- (84)      The strike was referred to briefly in the communique.  
           \*I saw the strike's brief reference to in the communique.
- Correct procedure was insisted on by Mary.  
           \*Correct procedure's insistence on by Mary was admirable.
- A recession is now hoped for.  
           \*A recession's hope for has receded.
- The delay was compensated for by an increase in cost.  
           \*The delay's compensation for was more than adequate.
- This problem was worked on by the Germans.  
           \*This problem's work on by the Germans was extensive.
- John approved of my behavior.  
           \*My behavior's approval (of) by John was gratifying.
- Cf. John approved the contract.  
       The contract's approval by John was gratifying.
- Such a tactic was unheard of fifty years ago.  
           This was an unprepared for surprise.  
           John is very well cared for.

Second, NP preposing in sentences with passive verbs or adjectives is associated with the insertion of the morphemes be-en, whereas these morphemes never appear in passive noun phrases.

Third, NP preposing is obligatory in sentences, once agent postposing has applied, whereas the possessive transformation is not. Thus, the "mixed" sentences corresponding to the "mixed" noun phrases of (81) are ungrammatical.

- (85)      \*Destroyed the city by the enemy.  
           \*Accepted the offer by John.  
           \*Arrested John by the police.

Fourth, the possessive transformation apparently can apply to other NP's besides the one immediately following the head noun, whereas NP preposing only applies to NP's which are not separated from V by an intervening NP. The condition on the possessive transformation is only that the NP moved be the object of an empty P when the rule applies. (Compare the examples in (84).) This condition allows certain time adverbial NP's whose preposition is deleted (cf. section II.3 for discussion) to be preposed by the possessive transformation, and this in fact happens:

- (86) I liked the discussion of novels by the librarian last week.  
I liked last week's discussion of novels by the librarian.
- The speech this morning by the president was optimistic.  
This morning's speech by the president was optimistic.

But such time adverbial NP's are not movable by NP preposing:

- (87) \*I liked it that last week was discussed novels by the librarian.  
\*This morning was spoken by the president.

(One could claim that the rule operating in (86) is different from the one operating in (83); but all I am really trying to show here is that there is a preposing rule inside NP's which is distinct from NP preposing, which produces passive sentences, and (86) is evidence for this in any case.)

These arguments all indicate that the possessive transformation is a separate (structure-preserving) rule in the grammar of English.

While we are speaking of movement rules inside NP's, it is appropriate to mention that the rule relating the pairs of sentences in (88) is also structure-preserving.

- (88) The corn's growth was rapid.  
The growth of the corn was rapid.
- The king's sleep should not be disturbed.  
The sleep of the king should not be disturbed.
- Mary commented on John's stupidity.  
Mary commented on the stupidity of John.
- The table's length exceeds its width.  
The length of the table exceeds its width.
- They disregarded John's belief that the world was cubic.  
They disregarded the belief of John that the world was cubic.

In view of the deep structure order of elements in sentences like (89), it appears that the first sentences in the pairs of (88) are more basic, whether or not one accepts the arguments in Chomsky (1970) that the sentences in (88) are not derived directly from structures underlying the sentences in (89).

- (89) The corn grew.  
The king slept.  
John was stupid.  
The table was long.  
John believed that the world was cubic.

This means that the rule relating the pairs of (88) is not the possessive transformation, but some different structure-preserving rule, say, NP postposing. Again, we can assume that this rule precedes of insertion and the insertion of 's, so that it applies as in (90).

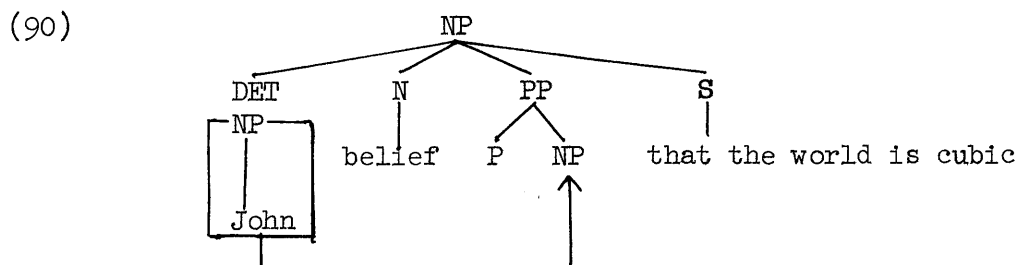



A final note in this section concerns the full paradigms of determiners that appear in the mixed noun phrases of (91).

- (91) Each defeat of Germany by Russia.  
 Those defeats of Germany by Russia.  
 Which defeat of Germany by Russia.  
 Any defeat of Germany by Russia.

To account for these examples, I introduce the notion that more than one constituent labeled X can be generated in deep structure in a given phrase structure position for X, as in (92).

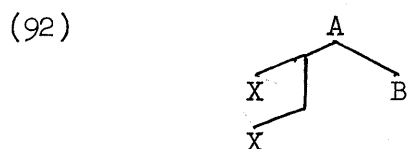

It is required only that at most one constituent with label X can appear in the given position in surface structure. This requirement has the consequence here of permitting other (lexical) determiners besides an NP to be generated under DET in deep structure, provided NP is removed transformationally. (That is, agent postposing or NP postposing are in effect obligatory if both a lexical determiner and an NP are generated under DET.) It also has the consequence of blocking the possessive transformation if a lexical DET other than the is present at the beginning of an NP. (We might want to insert the under an empty DET after all these NP movement rules inside NP's apply; I leave this matter open.)

Thus, the device of permitting "doubly-filled" (as well as "empty") nodes in deep structure seems to be appropriate for describing the interplay of lexical and NP determiners.

II.7 Obligatorily Reflexive Verbs Certain verbs in English cannot appear with a direct object other than a reflexive pronoun.

(93) The witness perjured herself.  
\*The witness perjured the lawyer.

Mary absented herself yesterday.  
\*Mary absented Martha yesterday.

The guests should avail themselves of the hotel's services.  
\*The guests should avail each other of the hotel's services.

The children were behaving (themselves) wonderfully.  
\*The mother was behaving the children wonderfully.

They braced (themselves) for a shock.  
\*They braced their parents for a shock.

The panelists repeat (themselves) too much.  
\*The panelists repeat the moderator too much.

Some of these verbs (perjure, absent, avail) have an obligatory reflexive object NP, while others (brace, behave, repeat) have an optional reflexive object NP. I return to this distinction below.

Especially since certain of these verbs do not require a reflexive object, it would seem that in deep structure they are all intransitive verbs in the sense that their meanings  $M(V)$  have only a subject position which may be interpreted. If this is the case, we can assume that the source of the reflexive object pronouns is a structure-preserving copying transformation which copies the subject NP into the object position. (The subject NP is, of course, not removed, but there is nothing in the definition of a structure-preserving movement rule which demands that an empty node be left behind.) This rule, the "identical object rule," is illustrated in (94). (TENSE is omitted in (94).)

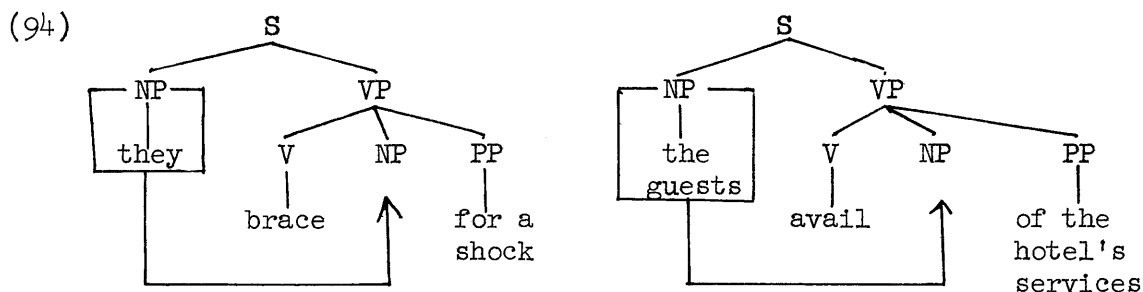

I assume that the appearance of a reflexive pronoun in (93) is due to the fact that reflexivization applies after the identical object rule.\*

A structure-preserving formulation of the identical object rule implies that it is not an accident that the redundant reflexive pronouns in sentences like (93) appear in object position rather than, say, before the verb, immediately after the subject, at the end of the VP, etc. Since these latter are not NP positions, a copying of an NP is not allowed in them, according to the structure-preserving constraint. That is, the structure-preserving constraint rules out a language A in which reflexives which alternate with other object NP's appear in object position but in which redundant reflexives, as in (93), appear in a position not typical of NP's. In (95), # signifies ungrammatical in A.

- (95)     The witness killed herself.  
           #The witness herself killed.  
  
           #The witness perjured herself.  
           The witness herself perjured.  
  
           The children were bathing themselves  
           #The children were themselves bathing.

---

\* An alternative analysis of the verbs in question could simply insert the reflexive pronoun NP into object position. This would be necessary if the usual source of reflexives (those that alternate with other NP's) is the base rather than the transformational component. But this insertion would be structure-preserving, in the sense that the remarks in the text à propos the examples of (95) apply equally as well to an identical object insertion rule as to a copying rule.

(95 cont.)

#The children were behaving themselves.  
 The children were themselves behaving.

We can account for the fact that the identical object rule is obligatory after some verbs (perjure, absent, avail) by assigning them the sub-categorization feature + \_\_\_NP. That is, we require that such verbs appear with an object NP in deep structure. The requirement that every node dominate a terminal element at some stage of a transformational derivation, and the fact that the only source for such an element in the object position after these verbs is the identical object rule insure that this rule must (rather than may) apply.

This use of obligatory sub-categorization to account for a transformation being obligatory is the same as was found in section II.2, in the discussion of indefinite subject movement and in section II.1, in the discussion of agent postposing into by phrases.

I have previously assumed that empty nodes can appear in complements to verbs even if the verb is not sub-categorized for such an optional node. (This question is distinct from the contention that an empty node satisfies an obligatory sub-categorization, provided it is filled during the transformational derivation.) This assumption bears on how we are to analyze verbs with optional reflexive objects, such as brace, behave, repeat, etc. However, the existence of such verbs does not validate or invalidate the assumption itself.

If empty nodes can appear even when non-empty object NP's are not allowed by sub-categorization, then we can assign the verbs like brace and behave the sub-categorization feature - \_\_\_NP. In all cases, the identical object rule is in itself optional (given the class of verbs in

(93)), and the difference between perjure, absent and avail vs. brace, behave, and repeat can be attributed to the obligatory sub-categorization feature + \_\_\_NP common to the former (but not the latter) class of verbs.\*

It should be clear, however, that the structure-preserving formulation of the identical object rule in no way depends on using sub-categorization to account for optional-obligatory conditions on this rule. Rather, once the structure-preserving framework is accepted, this is a device which becomes available.

The remarks above concerning the questionable sub-categorization of optionally reflexive verbs like brace, behave, and repeat apply as well to verbs other than be which can appear in constructions in which indefinite subject movement applies.

- (96)     A catastrophe occurred in that century.  
           There occurred a catastrophe in that century.
- A problem exists in this regard.  
           There exists a problem in this regard.

The meanings of these verbs M(V) have only a subject position. However, indefinite subject movement can remove the deep structure subject, placing it in a post-verbal NP position (probably the +PRED position). Again, if empty nodes were specified by sub-categorization, these verbs would have a feature + \_\_\_PRED. But if empty nodes do not have to satisfy a sub-categorization feature, as I am assuming, these verbs can be assigned the feature - \_\_\_PRED. (In either case, the meanings of these verbs M(V) do not have an object or predicate nominative

---

\* If empty nodes could appear only if the sub-categorization features of the verbs allow them, then verbs like brace and behave would have the optional feature + \_\_\_NP, even though their semantic meanings M(V) admit of no object position.

position.)

II.8 There Replacement Consider the pairs of sentences in (97).

- (97) a. There are some pine trees behind that barn.  
b. That barn has some pine trees behind it.

- a. There will be a hole in Jack's pocket.  
b. Jack's pocket will ~~have~~ a hole in it.  
b. Jack will have a hole in his pocket.

- a. There are some paintings hanging on the wall.  
b. The wall has some paintings hanging on it.

Ross (1967) argued that the (b) sentences of (97) should be derived from the (a) sentences by a rule he called "there replacement." (Ross did not explicitly mention sentences like the third pair in (97), however.) The movement part of this rule, which has the effect indicated in (98), is clearly structure-preserving. It should be stated so that either of the boxed NP's in a tree like (98) can be moved by it.

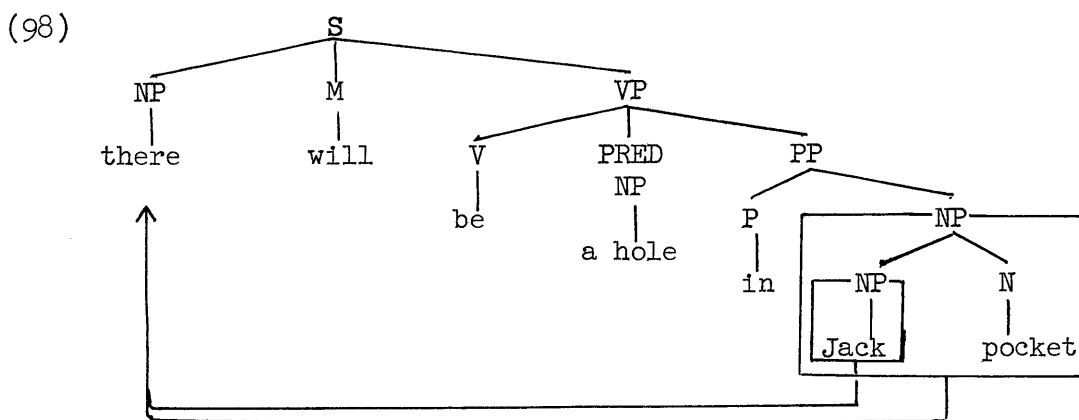

(I assume this rule applies before 's insertion. We could think of it as leaving behind either a pronoun copy or the original NP which is subsequently pronominalized, but not subsequently reflexivized.)

If a rule like there replacement is correct, it suggests that have

and be are inserted transformationally (under empty V's, in the structure-preserving framework), as suggested by Bach (1967). That is, have would be inserted under V's which are sisters to NP's which lack the feature +PRED (and into a few auxiliary positions, of no interest here), while be would be inserted under all other empty V's. In this view, the rule of there replacement would remove the PRED feature in trees like (98), and would apply before have and be were inserted. A de:facto effect of there replacement would be changing be to have, although only the feature +PRED would be mentioned in the rule itself. (This possible account of how have might result from applying there replacement is of course totally independent of the observation that there replacement is a structure-preserving rule.)

An alternative analysis which accounts for the alternations of (97) is given in Lee (1967). However, I disagree with enough of Lee's judgments of grammaticality so as to make a short yet adequate discussion of his ideas impossible here. That is, before I would want to discuss his analysis in the structure-preserving framework, I would have to justify certain modifications in it which would lead me too far afield at this point.

Conclusion to Chapter II I have discussed a wide variety of the NP movement rules which have been proposed by various transformationalists as part of a grammar of English: agent postposing, NP preposing, there insertion (indefinite subject movement), to dative movement, for dative movement, various it replacement rules (subject raising and object raising), conjunct movement, the possessive transformation, NP postposing, the identical (reflexive) object rule, and there replacement.

All of these rules, except the dative movement rules, are either obviously structure-preserving, or should be reformulated as structure-preserving according to arguments given in this chapter. The dative movement rules were shown to be structure-preserving, if we allow such rules to "exchange" constituents. However, if this is prohibited, dative movement rules also satisfy the basic defining condition of minor movement rules, which are the only non-structure-preserving rules that the structure-preserving constraint allows to apply in embedded sentences. (This class of rules will be studied extensively in Chapter V.) Thus, I conclude that the structure-preserving constraint, as defined in section II.1, limits the class of possible NP movement rules in English.

An appropriate question at this point is as follows: what NP movement rules of English which have found general acceptance in transformational analyses and which are not root transformations or minor movement rules have not yet been shown to support the structure-preserving hypothesis? I know of three: (i) The crucially important rule of wh fronting which operates in relative and interrogative clauses (embedded or not); this rule is discussed in section IV.5. (ii) The "complex NP shift rule" discussed in Ross (1967); this rule is discussed in section IV.6. (iii) The "focus placement" rule which plays a part in deriving cleft and perhaps pseudo-cleft sentences. This rule is discussed in section IV.2.1.

In the subsequent discussions of these three rules, we will see that there is evidence that all of them are structure-preserving. (However, the complex NP shift rule suggests a possible extension of the notion of structure-preserving rule -- see section IV.6.) Thus, the subsequent material in the paper will not weaken the claim that NP movement rules are subject to the structure-preserving constraint.



### CHAPTER III: THE STATUS OF EXTRAPOSITION

In this chapter, I will try to show that embedded sentences with finite verbs and introduced (at least optionally) by that and infinitives (with or without expressed subjects) are not instances of the constituent NP.\*

- (1)        John believed (that) Mary was a foreign agent.  
            John will see to it that you have a reservation.  
            Bill would prefer for Mary to stay awhile.  
            Barbara decided to buy a car.  
            That Bill knows German thoroughly is obvious to all.  
            To read so many magazines is a waste of time.  
            For the house to be painted would irritate him.

My arguments will differentiate such constituents not only from NP's with head nouns but also from the gerund constructions, underlined in (2). (Gerunds should be distinguished from participles, which will not be discussed here. Gerunds substitute for an NP, whereas participles modify NP's. Another difference is that participles never have an expressed subject apart from the NP they modify, whereas gerunds sometimes do have an expressed subject.)

- (2)        John regretted stealing Mary's book.  
            John will see to your getting a ticket in time.  
            Bill would prefer buying fewer foreign books.  
            Your being able to find a new job would be surprising.  
            Reading so many magazines seems a waste of time.  
            Mary's having so many books surprised him.

I will claim that the last examples of (1) and (2) should be represented in surface structure as (3) and (4) respectively.

---

\* This does not mean they cannot be part of an NP, as in "the fact that John came," "the decision to leave town," etc. I return to embedded sentences introduced by wh constituents rather than that (in particular, "indirect questions") in section IV.4.

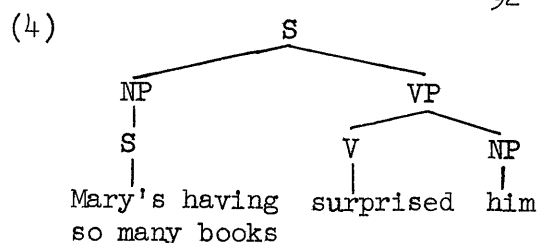
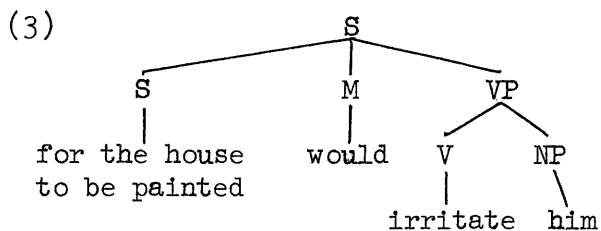

The deep structure I propose for (3) will be given in the course of the arguments to be presented.

The analysis of sentence and infinitive subject and object complements to be given here is at variance with that given in Rosenbaum (1967). Nonetheless, some of the grammatical facts he elucidated are important for establishing my hypothesis. On the other hand, I believe there are some flaws in his analysis, which I will discuss in this section. In section III.2, I show how the analysis of this chapter accounts for those aspects of Rosenbaum's analysis which were not faulty.\*

---

\* However, if one assumes that Rosenbaum's analysis of sentences and infinitives is correct, it is easy to see that his important rule of extraposition (whose status is the main topic of this chapter) is structure-preserving. Extraposition derives, for example, the second sentence of the following pair from the first.

For the house to be painted would irritate him.

It would irritate him for the house to be painted.

Since Rosenbaum's VP expansion rule generates an optional S in final position, extraposition (from subject position, in this case) has the following structure-preserving effect:

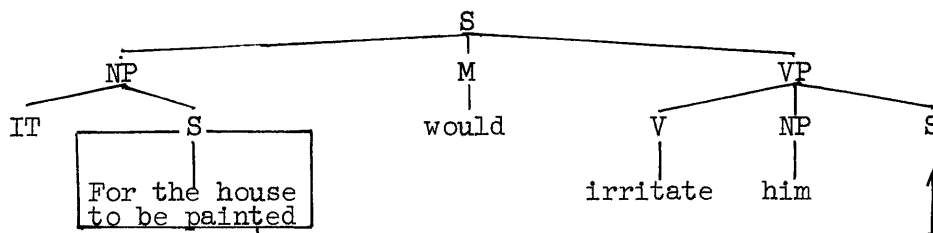

In fact, given the above assumption, confirmation that extraposition must be structure-preserving is given by the fact that if the S under VP is non-empty, a subject S may not be extraposed:

That John has blood on his hands proves (that) Mary is innocent.

\*It proves (that) Mary is innocent that John has blood on his hands.

To see that movie is to relive the past.

\*It is to relive the past to see that movie.

III.1 Arguments that Sentences and Infinitives are not NP's The arguments in this section consist generally in showing differences between sentences and infinitives on the one hand and gerunds and noun phrases with head nouns on the other which can be accounted for by assuming that only the latter two are instances of the constituent NP.

III.1.1 Two exceptional Classes of Gerunds However, I agree with Rosenbaum (1967) that there are two classes of gerunds (i.e., VP's whose heads have ing affixes and which are not participles) which are not NP's. One such class contains the complements to "verbs of temporal aspect" which include: begin, start, finish, continue, commence, stop, keep, keep on, go on, resume, cease, etc.

(5)                    John  $\left\{ \begin{array}{l} \text{began} \\ \text{kept} \\ \text{continued} \\ \text{resumed} \\ \text{stopped} \end{array} \right\}$  eating that steak.

(In (5), I am concerned only with the senses in which John is the understood subject of eat.) Two reasons for not considering eating that steak in (5) as an NP are that this constituent cannot be the subject of a passive sentence (this argument is due to Rosenbaum), nor can it be the focus constituent in a cleft construction, as can other NP's.

---

(footnote cont.)

That John is late persuades me that the train was delayed.

\*It persuades me that the train was delayed that John is late.

Thus, Rosenbaum's analysis supports the structure-preserving constraint. On the other hand, the structure-preserving constraint leads to a reanalysis of Rosenbaum's work, which, as will be seen in the text, also accounts for the above sentences.

- (6) \*Eating that steak was  $\left. \begin{array}{l} \text{begun} \\ \text{kept} \\ \text{continued} \\ \text{resumed} \\ \text{stopped} \end{array} \right\}$  by John.
- \*It was eating that steak that John  $\left. \begin{array}{l} \text{began} \\ \text{kept} \\ \text{continued} \\ \text{resumed} \\ \text{stopped} \end{array} \right\}$ .

Another class of gerunds which are not VP's are the VP complements to many transitive verbs of perception (see, watch, observe, notice, smell, hear, listen, feel) and to a few other verbs like find, catch, etc.

- (7) I saw John cleaning the table.  
They noticed some smoke coming out of the window.  
John found her studying algebra.

These complements can be shown to be reduced progressive forms of infinitives. First, infinitives after these verbs lack a characteristic to.

- (8) I saw John clean the table.  
They noticed some smoke come out of the window.

But, infinitives in progressive form are excluded:

- (9) \*I saw John be cleaning the table.  
\*They noticed some smoke be coming out of the window.

We can account for this by deriving the sentences of (7) from those in (9) by a be deletion rule. The underlying progressive nature of the forms in (7) is confirmed by observations like the following:



The crucial difference between mine and Rosenbaum's analysis is that I take the S in (12) to also be the deep structure source for the sentential and infinitival subject and object complements underlined in (1) and (2) above (where the verbs are believe, prefer, irritate, seem, etc.)

This immediately raises numerous questions, the most obvious perhaps being how I can account for the interpretations of the complements in (1) and (2) as objects and especially subjects, if I claim that these complements have the same post-verbal deep structure positions. I think the question can be adequately answered in a fairly simple way, and I return to it in section III.2 after I have established my analysis on syntactic grounds. The question is essentially concerned with the semantic component, since it is in this component and not in syntax or phonology that grammatical relations are used.

An alternate way to state my position is to say that the phrase structure rule  $NP \rightarrow S$  (perhaps alternatively  $NP \rightarrow NP - VP$ ) is never the source for infinitives or sentences introduced by that. It is rather the source of gerunds.

An initial advantage of this assumption is that the rule differentiating between to and ing as VP markers can be stated in terms of a well-motivated (as we shall see) structural difference between S's which are NP's and those which are not, rather than in terms of an ad hoc feature, as in Rosenbaum.\*

---

\*The complements to verbs of temporal aspect introduced by V-ing which were discussed above are irregular exactly in that they are exceptions to this rule. A way to remove this exception would be to assume the analysis of Newmeyer (1969) that the VP complements to verbs of temporal aspect originate in the subject NP, and are postposed by a (structure-preserving) rule as follows:

I now turn to an examination of various NP positions, and attempt to show that, in each such position, sentences and infinitives either do not occur or they are not present in this position in deep structure.

III.1.3 The Position of Object Complements It might at first be thought that the underlined complements in (15) are NP's, whereas these complements are extraposed (no longer NP's) in the corresponding synonyms of (16).

- (15) John already said that he was sick yesterday.  
 They proved that John had taken bribes in District Court.  
 Mary promised to be quiet reluctantly.  
 I like it that they played those records very much.

- (16) John already said yesterday that he was sick.  
 They proved in District Court that John had taken bribes.  
 Mary promised reluctantly to be quiet.  
 I like it very much that they played those records.

However, the adverbs which can precede or follow object clauses in (15) - (16) are those adverbs which are not closely tied to the verb: locative adverbs of space and time, manner adverbials, etc. These same classes of adverbs can in fact precede or follow extraposed subject clauses, as in (17).

(footnote cont.)

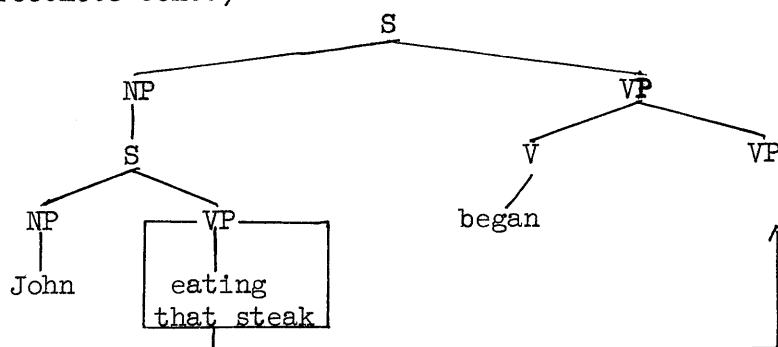

We could account for the presence of ing rather than to by inserting ing in gerunds before this postposing applies.

- (17) It seems that victory is unattainable today.  
 It seems today that victory is unattainable.
- It proves nothing to demonstrate simultaneity in Einstein's framework.  
 It proves nothing in Einstein's framework to demonstrate simultaneity.
- It isn't required that the players be tall in this school.  
 It isn't required in this school that the players be tall.
- It pleased me that they played those records very much.  
 It pleased me very much that they played those records.
- It doesn't frighten me to watch horror movies anymore.  
 It doesn't frighten me anymore to watch horror movies.
- It isn't necessary to be smart on this campus.  
 It isn't necessary on this campus to be smart.

In section IV.3, I will propose an adverb movement rule by which adverbs originally outside a VP may move inside it (so as to precede an extraposed S), in order to account for the alternations in (17). If we assume that the underlined complements in (15) - (16) have the same (extraposed) status as those in (17), this adverb movement rule automatically accounts for (15) - (16). Thus, (15) - (16) are irrelevant for deciding whether object clauses are ever found in the object NP position or whether they are always generated in extraposed position. The real test for deciding this question is the order of object clauses with respect to phrases whose meanings are determined by the head verb, such as those underlined in (18).

- (18) They told a fairy tale to the children.  
 They told the children a fairy tale.  
 \*They told how to build a kite to the children.  
 They told the children how to build a kite.
- \*She won't tell she is sick to the doctor.  
 She won't tell the doctor she is sick.



(18) cont.

- You promised a new hat to Mary.  
 You promised Mary a new hat.  
 \*You promised to be quiet to Mary.  
 You promised Mary to be quiet.
- \*You promised you would do the wash to Mary.  
 You promised Mary you would do the wash.
- The man taught the importance of books to his sons.  
 The man taught his sons the importance of books.  
 \*The man taught that books were important to his sons.  
 The man taught his sons that books were important.
- I take this responsibility upon myself.  
 \*I take to fix the lamp upon myself.  
 I take it upon myself to fix the lamp.
- They expect some co-operation of (from) you.  
 \*They expect that you co-operate of you.  
 They expect it of you that you co-operate.
- John said something nasty to Mary.  
 \*John said to leave him alone to Mary.  
 John said to Mary to leave him alone.
- Bill got a free meal.  
 Bill got to eat out.  
 Bill got a free meal for Joe.  
 Bill got Joe a free meal.  
 \*Bill got to eat out for Joe. (where Joe is the understood  
 subject of eat out)  
 Bill got Joe to eat out.

The underlined PP's in (18) are deep structure sisters to V, and in every case an infinitive or sentence object complement must follow them. (I make no attempt to explain in principled fashion why an it sometimes appears in object position in (18) and sometimes does not.) Thus, there is no distributional evidence that such complements occur in object NP position in deep structure. (That is, extraposition from object position in Rosenbaum's framework is always obligatory.)

#### III.1.4 Sentences and Infinitives in Other Non-Subject NP Positions

A clear-cut indication that infinitives and sentences are not in the same

category as gerunds and noun phrases with head nouns is that the latter two but not the former two appear after the traditional class of prepositions (from, at, into, toward, by, with, on account of, because of, despite, etc.).

- (19) John just came back from his job.  
 John just came back from driving a cab.  
 \*John just came back from to drive a cab.  
 \*John just came back from that he drove a cab.

He blamed it on Bill's strictness.  
 He blamed it on Bill's being too strict.  
 \*He blamed it on for Bill to be too strict.  
 \*He blamed it on that Bill was too strict.

Because of John's age, Mary gets a pension.  
 Because of John's being so old, Mary gets a pension.  
 \*Because of for John to be so old, Mary gets a pension.  
 \*Because of that John is so old, Mary gets a pension.

\*Because John's age, Mary gets a pension.  
 \*Because John's being so old, Mary gets a pension.  
 Because John is so old, Mary gets a pension.

It might be thought that the future participle, "about + infinitive", is an exception to the prohibition on infinitives after prepositions, but this about has no semantic or syntactic connection with the preposition about; for example, the future participle is not a PP:

- (20) It is about New York that they are talking.  
 \*It is about to leave that John seems.

Prepositions do appear in pseudo-cleft constructions which have sentences and infinitives in focus position, as in (21). This is sometimes taken as certain evidence that the traditional class of prepositions does appear before infinitives and sentences in underlying syntactic structure.

- (21)       What we are aware of is that she is poor.  
               What he insisted on was that we not pay for the food.

Whether (21) is evidence for this contention or not depends, however, on one's analysis of the pseudo-cleft construction. For consider a pseudo-cleft construction of the form (22):

- $$(22) \quad \left( \left( \begin{array}{c} \text{what} \\ \text{where} \\ \text{when} \end{array} \right) \right) - X - Y \quad \left( \begin{array}{c} \text{focus constituent} \\ C \end{array} \right) - \text{be} - \left( \begin{array}{c} \\ C \end{array} \right)$$

Can (22) be derived by a deletion of the second X and Y in an assumed underlying structure of the form (23)?

- $$(23) \quad \left( \begin{array}{c} S \\ S \end{array} X - \left( \text{wh} - \text{something} \right) - Y \right) - \text{be} - \left( \begin{array}{c} S \\ S \end{array} X - C - Y \right)$$

Suppose the answer is yes, and consider (24). In the first sentence, for example, X = John should be doing, Y =  $\emptyset$ , and C = working the bar.

- (24)       What John should be doing is working the bar.  
               What John was doing to Bill was kicking him in the shins.

In these sentences, X dominates ing; but C dominates ing also, implying two ings in the underlying righthand S in (23), hardly a satisfying result. The problem is the assumption that (23) is the underlying structure of a pseudo-cleft of the form (22).

The undesired consequence of this assumption can be avoided if we replace "wh - something" in (23) with W, where W dominates "wh - something" and is subject to other conditions. But then W can be constituents like "doing wh - something" or "of wh - something", and it no longer necessarily is so that prepositions must precede sentences and infinitives (i.e., be the last element in X in (23)) in deep structure.

Thus, any analysis of the pseudo-cleft construction which assumes that the focus constituent is the remnant of a deep structure sentence on the right-hand side of the copula does not require that I abandon the claim that infinitives and sentences do not appear as NP's after prepositions. There are other possible approaches to pseudo-cleft constructions, but I think that arguments to the same effect as the one I have given here could be constructed for any precise alternative analysis of pseudo-cleft sentences.

Infinitives and sentences do not appear before 's in gerunds and noun phrases with head nouns, but this alone proves nothing, since gerunds and certain other "complex" noun phrases, from which we are trying to differentiate them, do not either. However, there is a discernable difference in ungrammaticality between gerunds before 's and infinitives before 's, the latter being less acceptable. Compare:

- (25) \*Does he know about smoking pot's being illegal?  
 \*(worse) Does he know about to smoke pot's being illegal?

This intuition can be strengthened by noting that, in most American speech, 's can be omitted in many cases after the subject of a gerund. When this optional rule is applied to the sentences in (25), the result is that the first, but not the second, sounds completely acceptable.

- (26) Does he know about smoking pot being illegal?  
 \*Does he know about to smoke pot being illegal?  
 Cf. Does he know about it being illegal to smoke pot?

We agree about shoveling snow being ridiculous.  
 \*We agree about to shovel snow being ridiculous.  
 Cf. We agree about it being ridiculous to shovel snow.

Actually, the same kind of change in acceptability between (25) and (26) appears when NP's with N heads, as well as gerunds, lose their 's.

- (27) \*I didn't know about the purchase of a car's putting them into  
bankruptcy.  
I didn't know about the purchase of a car putting them into  
bankruptcy.

This further demonstrates the similarity between gerunds and other NP's, as well as the dissimilarity between gerunds and infinitives.

A few examples with NP's in appositive positions are perhaps in order. Very little is known about the special properties of this construction. However, in connection with our concern here, we can note that infinitives, although interpretable in this position, are not as natural as gerunds. Compare, for example, the infinitives and gerunds used as appositives in (28).

- (28) All this constant activity, buying food twice a day and going  
out every night, is wearing me out.  
\*All this constant activity, to buy food twice a day and to go  
out every night, is wearing me out.
- We have finished the most irksome part, filling out the long  
registration form.  
\*We have finished the most irksome part, to fill out the long  
registration form.

Thus, by examining non-subject NP positions, we can see that infinitives and sentences generally do not occur as NP's.

III.1.5 Sentences and Infinitives in Subject Position Sentences and infinitives occur in surface structure in subject position, as in the examples of (1), repeated here for convenience.

- (29) That Bill knows German thoroughly is obvious to all.  
To read so many magazines is a waste of time.  
For the house to be painted would irritate him.

According to the analysis I am pursuing, these sentences must be

derived from the corresponding sentences in (30), since the only source for sentence and infinitive complements is the "extraposed" S (and perhaps VP) generated by (12).

- (30) It is obvious to all that Bill knows German thoroughly.  
 It is a waste of time to read so many magazines.  
 It would irritate him for the house to be painted.

A straightforward rule to accomplish this derivation would be one which replaces a subject NP dominating it (or perhaps nothing at the point when the rule applies) with the complement S, as in (31). I will call this rule "subject replacement." (Care will have to be taken to insure that the only S's which undergo subject replacement are those which are in fact interpreted as deep structure subjects. I take up this question in section III.2.)

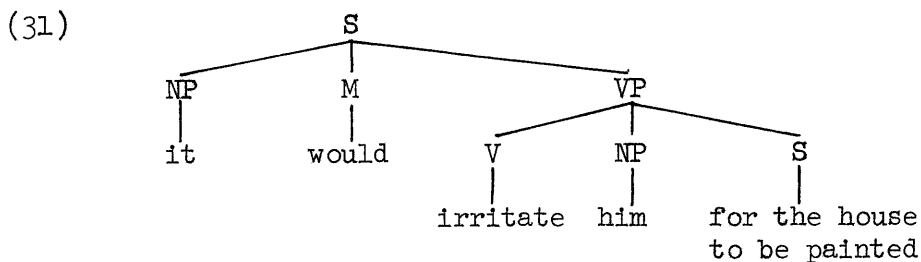

The result of applying subject replacement to (31) was given earlier as

(3):

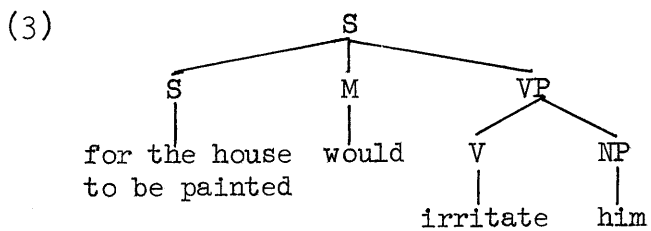

According to this formulation, subject replacement is not a structure-preserving rule. But the structure-preserving constraint then requires that it be a root transformation. That is, it must not apply in non-root S's. This is in fact the case; gerunds, but not infinitives or sentences, are acceptable subjects in non-root S's.\*

- (32) \*That for Bill to smoke bothers the teacher is quite possible.  
 That it bothers the teacher for Bill to smoke is quite possible.  
 That Bill's smoking cigarettes bothers the teacher is quite possible.
- \*For that you pay that tax to be necessary would be an inconvenience.  
 For it to be necessary that you pay that tax would be an inconvenience.  
 For paying that tax to be necessary would be an inconvenience.
- \*He protested the decision that for the bill to be marked paid meant nothing.  
 He protested the decision that it meant nothing for the bill to be marked paid.  
 He protested the decision that the bill's being marked paid meant nothing.
- \*John was happy that to own a car didn't disqualify you.  
 John was happy that it didn't disqualify you to own a car.  
 John was happy that owning a car didn't disqualify you.
- \*I don't believe for you to take that course was worth it.  
 \*I don't believe that you took that course was worth it.  
 I don't believe your taking that course was worth it.
- \*He didn't want that he was Indian to be known at his club.  
 He didn't want it to be known at his club that he was Indian.  
 ?He didn't want his being Indian to be known at his club.  
 ?His being Indian wasn't known at his club.  
 (The grammaticality of a subject gerund does not depend on the notion "root S".)
- \*A day at the beach is more fun than to play golf is.  
 A day at the beach is more fun than playing golf is.
- \*These car-rides don't seem as rewarding as to ride a horse used to seem.  
 These car-rides don't seem as rewarding as it used to seem to ride a horse.

---

\* When gerunds are not acceptable, they are not acceptable in roots either: \*"John's going downtown was false," etc.

(32 cont.)

These car-rides don't seem as rewarding as riding a horse used to seem.

\*I ran so fast that to breathe deeply wore me out.  
I ran so fast that breathing deeply wore me out.

\*Although that the house is empty may depress you, it pleases me.  
\*Although for the house to be empty may depress you, it pleases me.  
Although the house's being empty may depress you, it pleases me.

\*The children for whom to diagram sentences is easy often become mathematicians.  
The children for whom it is easy to diagram sentences often become mathematicians.  
The children for whom diagraming sentences is easy often become mathematicians.

\*She likes the kind of man that to see a few movies a year will satisfy.  
She likes the kind of man that it will satisfy to see a few movies a year.  
She likes the kind of man that seeing a few movies a year will satisfy.

The contrasts in grammaticality in (32) are a necessary consequence of the structure-preserving hypothesis if we assume that sentence and infinitive complements are generated at the end of the VP by (12).

On the other hand, the contrast must be accounted for in ad hoc fashion in Rosenbaum's framework. That is, the extraposition rule carries a condition that it is obligatory on a sentence or infinitive subject of a non-root S.

A previous attempt to attribute this condition to a more general principle was made by Ross (1967). He proposed that it is due to a general prohibition on the configuration  $\begin{array}{c} \text{NP} \\ | \\ \text{S} \end{array}$  in "sentence interior" position. As Ross himself pointed out, however, the fact that gerunds, which may be S's dominated by NP's, occur in sentence interior position casts doubt on the generality of this constraint. A clearer counter-



example is provided by "headless" relative clauses, which occur quite freely in sentence interior position.

(33) She won't tell { what she heard } to the doctor.  
                                   { \*she is sick }

The man taught { what he had learned from the missionaries }  
                                   { \*that the missionaries were evil }

to his sons.

He takes { whatever is necessary to prove his point } for granted.  
                                   { \*that his assumptions are unchallengeable }

John was happy (that) { what he had done } hadn't disqualified him.  
                                   { \*to own a car }

I never assumed { what I heard on the news } was true.  
                                   { \*that we were in danger }

He ran so fast that { what he had on fell off. }  
                                   { \*to breathe deeply wore him out. }

Although { what I have learned } doesn't impress you, it did her.  
                                   { \*that I own a yacht }

The children for whom { whatever the teacher says } is  
                                   { \*that the teacher is always right }  
                                   gospel aren't very interesting.

He protested the decision that

{ however much had not been paid would be added to his taxes. }  
                                   { \*for the bill to be marked paid meant nothing. }

For { what that company makes } to be well-known would surprise  
                                   { \*that they make saddles }  
                                   me.

I conclude that the condition that infinitives and sentences must be extraposed in non-root S's is an ad hoc condition in Rosenbaum's framework, and not the consequence of a universal principle.

The subject replacement rule (i.e., my counterpart to extraposition) has further similarities to root transformations. As Ross noted in formulating the constraint just discussed, a sentence or infinitive complement cannot appear in subject position if anything (at least,

anything which is not separated from the subject by a comma) precedes this position.

(34) Why did { \*that Mary liked old records } irritate him?  
           Mary's liking old records

Is { \*that this stock will be sold } certain?  
       ?this stock's being sold

Cf. ?This stock's being sold is certain.

When was { \*to arrive an hour early } a requirement?  
           arriving an hour early

\*Never will for us to be comfortable be possible in this climate.  
 Never will it be possible for us to be comfortable in this  
 climate.

A disease like that { \*to take a lot of pills } won't cure.  
                           ?taking a lot of pills  
                           ?frequent exercise

This is automatically accounted for in the analysis I am pursuing, once we note that this is a general condition on all the fronting root transformations of English: only one of them can apply in a given S. To see that this is so, let us list the preposing root transformations studied in Chapter I.

- (35) Directional adverb preposing (a)  
 Negated constituent preposing (b)  
 Direct quote preposing (c)  
 Non-factive complement preposing (d)  
 Topicalization (e)  
 VP preposing (f)  
 Left dislocation (g)  
 Comparative substitution (h)  
 Participle preposing (i)  
 PP substitution (j)

Also subject to this condition, for reasons unknown to me, is wh fronting (k). We first note that the ungrammatical examples of (34) are forbidden combinations of the preposing root transformation of subject replacement with (b), (e), and (k). Combinations of rules (a) through (k) with each other, all of which produce ungrammaticality, are given in (36). The

notation (x-y) after the examples in (36) means that first rule x and then rule y applies to yield the example in question.

- (36)
- \*John, away he ran. (a-g)
  - \*Away, John, he ran. (g-a)
  
  - \*This house into ran the boys. (a-e)
  
  - \*She never has bought a car, and buy one never will she. (b-f)
  - \*She never has bought a car, and never {will buy one she.} (f-b)
  - {buy one will she.}
  
  - \*These steps never did I sweep with a broom. (b-e)
  - \*Never did these steps I sweep with a broom. (e-b)
  - \*Never these steps did I sweep with a broom. (also e-b)
  
  - \*Which plays of his {never have} we read? (b-k)
  - {have never}
  
  - \*Who into the house dashed? (a-k)
  - \*Into the house who dashed? (k-a)
  
  - \*What {these steps did} you used to sweep with? (e-k)
  - {did these steps}
  
  - \*These steps {what did} you used to sweep with? (k-e)
  - {did what}
  
  - What did he assume all the people in the crowd were carrying?  
All the people in the crowd, he assumed, were carrying flags.
  - \*All the people in the crowd, what did he assume, were carrying? (k-d)
  
  - \*My brother, only a few students did he meet in the east. (b-g)
  - \*Only a few students, my brother, did he meet in the east. (g-b)
  
  - \*In this field never has a memorial stood. (b-j)
  - ?Never in this field has a memorial stood. (j-b)
  
  - \*"Bill likes corn," John, he said, "but I don't." (g-c)
  - \*John, "Bill likes corn," he said, "but I don't." (c-g)
  
  - \*He said I would like her, and her like I do. (f-e)
  - \*John said she would help him willingly, and help willingly him she does. (e-f)
  
  - \*John, her he likes. (e-g)
  - \*Her, John, he likes. (g-e)
  
  - \*The president speaking to now is our top reporter. (i-e)
  - \*Speaking to now the president is our top reporter. (e-i)

(36 cont.)

\*Was among the guests standing John? (j-k)  
 \*Among the guests was John standing? (k-j)

\*What would easier to solve be? (h-k)  
 \*Easier to solve what would be? (k-h)

Thus, all the preposing root transformations (and wh movement) can apply only if no other transformation of the same type applies in the same root S. (I do not pretend to have captured this restriction in a formal way; I use it only to show that subject replacement is like other root transformations.) This restriction predicts, as a special case, the ungrammaticality of subject replacement in the root sentences of (34), since, in these examples, a constituent precedes the subject NP position as a result of a preposing root transformation (or wh fronting).\*

A study of the sentence and infinitive complements which occur in subject position thus favors the view that they originate at the end of the VP in deep structure. For it is this assumption, coupled with the structure-preserving constraint, which automatically predicts the ungrammaticality of the sentence and infinitive subjects in (33) - (34). In Rosenbaum's framework, on the other hand, these facts can be accounted for only by an ad hoc condition making extraposition of a sentence or infinitive complement not immediately dominated by a root S obligatory rather than optional.

### III.1.6 Other Arguments Confirming the non-NP Status of Infinitives and Sentences (i) In noun phrases with noun heads, at some point in

\* Michael Brame has pointed out to me the possibility that the condition that no two preposing root transformations may apply in the same S may be a principle of universal grammar, and hence not a formal problem in the grammar of English.

the transformational derivation a rule must insert 's in the context  
 [NP [NP X \_\_\_\_\_] Y]. (This is not a deep structure condition,  
 because it is not an NP in this position in deep structure which receives  
 the 's in phrases like "John's expulsion by the principal.") But accord-  
 ing to this rule, gerunds should be noun phrases and sentences and  
 infinitives should not be, since the initial (subject) NP in gerunds but  
 not in infinitives and sentences can be followed by an 's suffix.

(ii) If sentences and infinitives are not NP's, they should  
 not conjoin freely with NP's. It was pointed out by Gleitman (1965)  
 that this is the case. On the other hand, gerunds and NP's with head  
 nouns can be conjoined.

- (37) She used to like watching television and physical exercise both.  
 \*She used to like watching television and to play volleyball  
 both.  
 \*She used to like to watch television and physical exercise both.  
 (where physical exercise is the object of like.)  
 \*She used to like physical exercise and to watch television both.

Outdoor bathrooms and pitching a tent every day would bother me.  
 \*To pitch a tent every day and outdoor bathrooms would bother me.  
 \*Eating canned foods and to pitch a tent every day would bother me.

He proposed a 20% reduction for the elderly and discontinuing  
 the translation service.  
 \*He proposed a 20% reduction for the elderly and that the office  
 be moved to the suburbs.  
 \*He proposed that the office be moved to the suburbs and dis-  
 continuing the translation service.

(iii) Rosenbaum noted that the extraposition does not apply to  
 gerunds:\*

---

\* The few exceptions to this, such as "It's fun talking to foreigners,"  
 should be classed with the non-NP ing complements to verbs of temporal  
 aspect discussed above.

- (38) \*It was understandable John's owning two cars.  
 \*It is irritating everybody in the back seat John's driving fast.  
 \*It never scared him when he was young sleeping in the dark.

Some speakers of English find the starred sentences of (38) acceptable, but even these demand that a comma-like pause precede the extraposed gerunds, so that what is probably involved is the right dislocation rule (a root transformation) discussed in Chapter I.

- (39) It was understandable, John's purchase of a gun.  
 It irritates everybody in the back seat, John's big cigar.  
 It never scared him when he was young, the skeleton in the closet.

Since gerunds do not appear "in extraposition" from the subject, the extraposition rule in Rosenbaum's framework must be made to depend on an ad hoc difference between gerunds and infinitives. But the counterpart of the extraposition rule in the framework of this study, the subject replacement rule, does not depend on (is not formulated in terms of) such an ad hoc feature. This is because gerunds and infinitives have different rather than the same underlying sources. This formal advantage is the result of generating both subject and object sentence and infinitive complements at the end of the VP.

(iv) I will try to show in section III.2 that certain (not all) of Rosenbaum's conclusions about complements from the way such complements behave in the pseudo-cleft construction are faulty. In particular, I will argue that the focus position of the pseudo-cleft construction is not a diagnostic context for the category NP.

On the other hand, we can replace Rosenbaum's pseudo-cleft test for NP status (which I will show to be unsatisfactory) with a more appropriate

one, the cleft test. Examples of the cleft construction, with the focus constituent underlined, are given in (40).

- (40) It's the custard pie that I disliked.  
 It was a tax break that I counted one.  
 Was it John that broke the window?  
 It was to John that she spoke.  
 It's because of the flood that they are leaving.  
 It is with great pleasure that I present our speaker.  
 It was buying a new hat that I enjoyed.  
 It was John's knowing the location of the mailbox that surprised her.  
 It was because it was raining that they left.

- \*It's very unhappy that Bill is.  
 \*It was useless that the meeting seemed.  
 \*It was explicitly that he rejected our assumptions.  
 \*It was too carefully that she spoke.  
 \*It is blow up some buildings that you should do.  
 \*It is playing for time that they are doing.  
 Cf. What you should do is blow up some buildings.  
     What they are doing is playing for time.  
 \*It was throwing away some letters that John noticed Bill.  
 \*It was ask John for money that I heard you.  
 \*It was stealing my money that she caught him.  
 \*It was drinking beer from the bottle that she kept.  
 \*It was to report on time that we failed.  
 \*It was that he passed out that John drank so much.

The cleft construction appears to be a perfect diagnostic for the categories NP and PP.\* In particular, the gerund can appear in focus position, as in two of the examples of (40). By this test, however, sentences and infinitives are not noun phrases:

- (41) \*It was to buy a new hat that I wanted.  
 \*It's for her to be late that upsets me.  
 \*It was that you explain your motives that was of importance.  
 \*It's that John has come too late that Bill realizes.  
 \*Was it that he bought dope for Mary that Bill admitted?  
 Cf. It's her being late that upsets me.  
     It was explaining your motives that was of importance.  
     Was it buying dope for his own usage that Bill admitted?

---

\* I am treating adverbs like now, before, inside and here as intransitive prepositions, and subordinating conjunctions like because, before, now that, and while as prepositions with S rather than NP complements. This is discussed in detail in section IV.3.

The ungrammaticality of the examples of (41) is automatically explained by generating sentence and infinitive complements at the end of the VP and designing the grammar so that just NP's and PP's appear in focus position in cleft sentences. (How this can be done in very natural fashion will be discussed in the next chapter.)

(v) There are several clausal constructions of various types, most of which are rather poorly understood, which seem to have one characteristic in common: they do not exhibit noun phrase behavior.

The horse is too old to ride far.  
 The table isn't high enough to write on.  
 John is as silly as Bill is smart.  
 Studies are more important than recreation is.  
 Golf is so dull that I threw away my clubs.  
 He is such a good dentist that I had all my teeth out.  
 John has the ~~same~~ model as (that) you have.  
 She was the second student to have swum the channel.  
 I still have Egypt to see.  
 This drawer is to store records in.  
 She is the last person that saw him.  
 The garage is easy to put a car into.  
 The workmen are about to install the phone.  
 John sent Mary a book to review.

The fact that so many diverse constructions which do not exhibit NP behavior are expressed as sentences and infinitives indicates that the few ing-introduced clause constructions which do not act like NP's (participles, for example) are the exceptional case. In fact, I have shown that the ing-introduced clauses after verbs of perception like see are reduced infinitives, and suggested (in a footnote) that the complements to verbs of temporal aspect (begin, resume, etc.) may originate in gerunds in underlying structure. Thus, we seem to be left with a grammar in which it is true both that NP's are never sentences and infinitives and that clauses which are not NP's are not (at least in the regular case) marked with an ing affix on the verb.



(vi) According to Rosenbaum's analysis, the underlined subject clauses in (42) are NP's.

- (42) For John to arrive would cause embarrassment.  
That the children are always late shows the necessity of discipline.  
That you spoke out of turn didn't help the situation.  
To suggest devaluation would anger the bankers.  
That the boys were dancing together was amusing John.

However, the agent postposing (passive) rule does not apply to these supposed NP's. Rosenbaum apparently was under the impression that agent postposing and a subsequent rule deleting by would produce grammatical sentences, but this is not the case either.

- (43) \*Embarrassment would be caused (by) for John to arrive.  
 \*The necessity of discipline is shown (by) that the children are always late.  
 \*The situation wasn't helped (by) that you spoke out of turn.  
 \*The bankers would be angered (by) to suggest devaluation.  
 \*John was being amused (by) that the boys were dancing together.

Rosenbaum was led to this conclusion by the existence of sentences like those in (44).

- (44) John was disturbed (\*by) that the neighbors were so noisy.  
 Mary was pleased (\*by) that she had found a job.

But such sentences are due to the fact that disturbed and pleased are "passive adjectives," similar to sorry and glad in (45), as well as passive verb forms.

- (45) John was sorry (\*by) that the neighbors were so noisy.  
 Mary was glad (\*by) that she had found a job.

We know the passive forms that appear in sentences like (44) are adjectives because they can be modified by characteristically adjectival modifiers

like very.

- (46) John was very disturbed that the neighbors were so noisy.  
 Mary was very pleased that she had found a job.  
 John was very sorry that the neighbors were so noisy.  
 Mary was very glad that she had found a job.

\*Embarrassment would be very caused by his arrival.  
 \*The necessity of discipline is very shown by their tardiness.  
 \*The situation wasn't very helped by your comments.  
 \*John was being very amused by their antics.

(Angered and amused are also passive adjectives and can be used alone with very; the ungrammaticality of the last two examples in (43) is due to the fact that these adjectives can't be used with infinitive complements or with the progressive.)

Another proof that the passive forms in (44) are adjectives is their ability to appear after seem.

- (48) John seemed { disturbed } that the neighbors were so noisy.  
                   sorry  
 Mary seemed { pleased } that she had found a job.  
                   glad

\*Embarrassment seemed caused by his arrival.  
 \*The necessity of discipline seemed shown by their tardiness.  
 \*The situation didn't seem helped by your comments.

Finally, we know the passive forms in (44) are not verbs because they could occur with the progressive if they were:

- (49) That the neighbors were so noisy was disturbing John.  
 ?That John is looking for a job is pleasing Mary.  
 That John didn't have a job was depressing Mary.

\*John was being disturbed that the neighbors were so noisy.  
 \*Mary is being pleased that John is looking for a job.  
 \*Mary was being depressed that John didn't have a job.

These three arguments show that agent postposing doesn't apply to

sentences and infinitives. This means that the agent postposing rule requires an ad hoc condition in Rosenbaum's framework. This condition simply states that sentences and infinitives do not act like NP's as far as agent postposing is concerned, thus reflecting directly my contention that these constructions are never NP's.

In the framework I am proposing, the underlined subject clauses in (42) are generated at the end of the VP, and moved to subject position by the subject replacement rule. By ordering subject replacement after the passive rules, the generation of the examples of (43) is avoided. We know on independent grounds that this ordering is correct because sentence and infinitive clauses can also replace deep structure object instances of it which are moved to the subject position by the NP preposing rule:

- (50) That John is brilliant is known by few people.  
 For John to be arrested would be condemned by the newspapers.  
 That we have permits will be proven by our willingness to  
     show our luggage.  
 That Mary stay the night was insisted on by Susan.  
 To remain silent was preferred by everyone.  
 That the house was old was denied by John.

I conclude that the fact that agent postposing does not apply to sentence and infinitive subjects in Rosenbaum's framework is a fault that can be eliminated if we assume that sentence and infinitive complements are always generated at the end of the VP.\*

---

\* There remains a question about my analysis which deserves an answer. As should be clear, I take the deep structure strings for the sentences of (42) to be as follows:

- It would cause embarrassment for John to arrive.  
 It shows the necessity of discipline that the children are  
     always late.  
 It didn't help the situation that you spoke out of turn.  
 It would anger the bankers to suggest devaluation.

In this section I have given six supporting arguments that sentences and infinitives are not instances of the configuration NP. In the following section, I will show how certain grammatical phenomena which are accounted for adequately in Rosenbaum's grammar can equally well be described in the revised grammar I am proposing, though in a somewhat different fashion.

---

(footnote cont.)

It was amusing John that the boys were dancing together.

Suppose now we form the passive construction without applying subject replacement:

\*Embarrassment would be caused by it for John to arrive.

\*The necessity of discipline is shown by it that the children are always late.

\*The situation wasn't helped by it that you spoke out of turn.

\*The bankers would be angered by it to suggest devaluation.

\*John was being amused by it that the boys were dancing together.

I must be able to explain this unexpected ungrammaticality in order to preserve the integrity of my analysis.

In section II.1 I argued that the passive by phrase is present in deep structure, being distinguished from other deep structure PP's only by the fact that its object NP is empty. If such a PP is not present, agent postposing cannot apply, since this rule is structure-preserving.

Now there is a general prohibition against a great many (but not all) combinations of PP's and complement S's. I attribute the ungrammaticality of the above examples to the same prohibition.

\*I agree with it that John walked out.

\*We talked about it that the weather was warm.

\*John spoke against it for Bill to receive the prize.

\*We took a vote on it that John had a right to speak.

Cf. John saw to it that we had reservations.

If one objects that the above underlying strings are permitted, but are simply changed into gerunds transformationally (see examples following), the same reasoning can be applied to the combination by-NP-S. In either case, the by phrase has the same status as a number of other PP's.

I agree with John's walking out.

John spoke against Bill's receiving the prize.

We talked about the weather's being warm.

We took a vote on John's having a right to speak.

Embarrassment would be caused by John's arriving.

The necessity of discipline is shown by the children's always being late.

The situation wasn't helped by your speaking out of turn.

The bankers would be angered by suggesting devaluation.

John was being amused by the boys' dancing together.

### III.2 An Alternative to Rosenbaum's Explanations

III.2.1 Rosenbaum's Noun Phrase Complements Sentences such as those in (51) are often taken as evidence that the underlined antecedents of it must be NP's:

- (51) John tends to eat too much, although Mary disapproves of it.  
 John guessed that Mary would be coming, although I had said nothing about it.  
 If this house had fewer windows, it would bother me.  
 It would have been pointed out by John if there had been any danger.

However, it seems to me that the sentences of (51) only show either that the underlined antecedents of it are NP's or that it may have antecedents which are S's.\* In the absence of other pertinent arguments, these sentences could not decide for us which conclusion it would be correct to draw.

In the previous section, I gave several independent arguments that the underlined constituents in (51) are not NP's. Hence I conclude that it may also have S antecedents. Assuming that a pronoun and its antecedent are marked with co-referential indices, the fact that S's do not appear in NP positions in deep structure (as shown previously) suggests a theory of co-reference in which some (perhaps all) anaphoric pronouns are generated in the base and in which structural conditions for co-referentiality of constituents are stated for various grammatical levels. That is, certain co-referential pairs of constituents are prohibited according to structural conditions or constraints defined at the deep structure level, at the surface structure level, or at some (or all)

---

\* Assuming, as I will throughout this section, that infinitives are reduced S's.

intervening levels. One of the conditions which must ordinarily be fulfilled in order for two constituents to be co-referential, for example, is that one of them be a pronoun (or an epithet).

Given such a theory, a natural way to explain how a sentence or infinitive complement "in extraposition" (at the end of the VP) in deep structure is interpreted as a subject or object of a given verb is to assume that such a complement is co-referential with an it in the appropriate subject or object NP position. Thus, the embedded S in (52) is interpreted as the subject of the verb, and the embedded S in (53) is interpreted as the object of the verb.

(52)

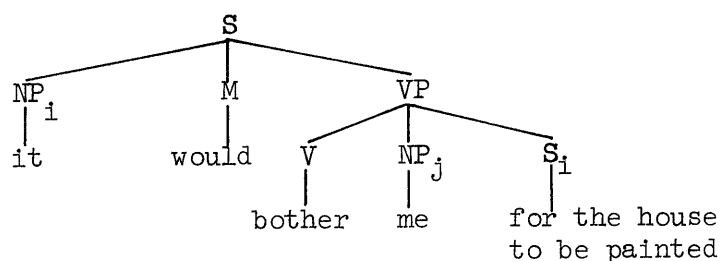

(53)

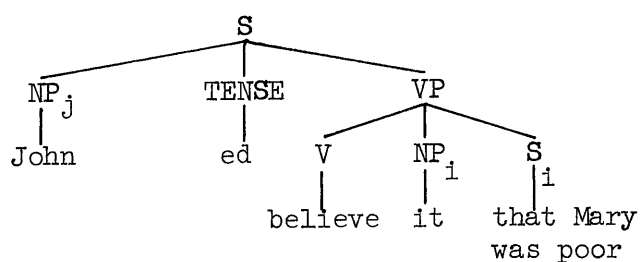

The embedded S's in (54), and hence the larger trees of which they form a part, are uninterpretable because the meanings of the main verbs in these trees do not admit of "oblique" S complements,\* but only of

---

\* An oblique S complement is one which is not co-referential with a subject or object it; such complements will be discussed in the next section. They correspond roughly to Rosenbaum's "Verb Phrase Complements", whereas the complements under discussion here correspond to his "Noun Phrase Complements."

I am assuming that each verb V has a lexical semantic meaning M(V)

subjects and objects. (That is, no special sub-categorization conditions are needed to exclude the trees of (54); the projection rule for forming the meaning of an S from the lexical meaning of the main verb of S cannot operate on trees with superfluous constituents not specified in the meaning of that verb.)

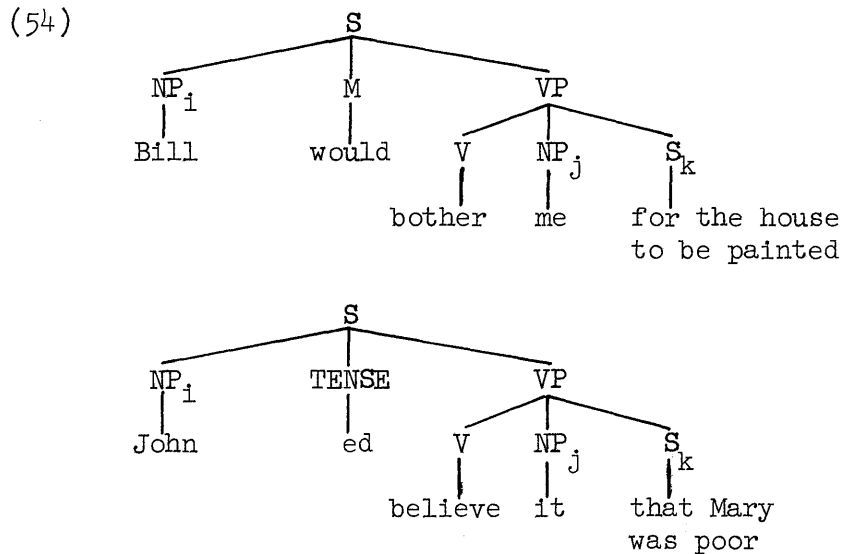

The theory of verb complementation I am proposing agrees with that of Rosenbaum's in an interesting way: the distribution of the deep structure it's whose antecedents are sentence and infinitive (but not gerund) complements is essentially the same in both theories. In Rosenbaum's analysis, NP complement clauses are generated by the phrase structure rule: NP → IT - S, where a surface structure IT dominates the terminal symbol it. In each case (excepting the complements to a very few verbs

---

(footnote cont.)

which contains some combination of the symbols X ("subject position"), Y ("object position"), and Z ("oblique position"). Thus, M(V) = ...X...Y...Z... for a verb with three complements. The definitions of grammatical relations in terms of deep structure trees specify the constituents whose meanings are to be placed in the X, Y, and Z positions of M(V) so as to obtain (at least part of) the meaning M(S) of the sentence of which V is the main verb.

like seem, which I discuss in the next section) that Rosenbaum postulates a deep structure configuration

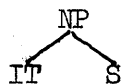

for a sentence or infinitive

complement, I postulate a deep structure  $\begin{array}{c} \text{NP}_i \\ | \\ \text{it} \end{array}$ , where  $\text{S}_i$  appears

simultaneously at the end of the VP "in extraposition." The difference between the two analyses is that Rosenbaum considered IT to always be a deep structure sister to its S antecedent, while I consider the corresponding it to be co-referential with its antecedent S, which is in extraposition.

Rosenbaum's rule of IT-deletion, ordered after his extraposition rule, is essentially (55).

$$(55) \quad [\text{NP IT - S}] \Rightarrow \emptyset - 2$$

Certain discrepancies as in (56) must be accounted for in Rosenbaum's framework by special conditions either on (55) or on the extraposition rule itself.

- (56)      John believed (it) that Mary was coming.  
             John thought (\*it) that Mary was coming.  
             John liked it that Mary was coming.  
             \*John liked that Mary was coming.

In the framework I am proposing, the conditions which determine the examples of (56) aside, it deletion can be restated as (57).

$$(57) \quad \text{NP}_i - \text{S}_i \Rightarrow \emptyset - 2$$

(Of course,  $\text{NP}_i$  can **dominate only** it if a co-referential  $\text{S}_i$  appears in the same tree.)

Similarly, the subject replacement rule must be stated in terms of



co-referential indices, as in (58).

(58)  $[S \text{ NP}_i - X - S_i - Y] \Rightarrow 3 - 2 - \emptyset - 4$

where no NP, PP, or S  
dominated by the S whose  
subject is replaced  
dominates 3.

The condition on (58) prevents S's which are "too far down" in the tree from replacing the subject. An example of such an S in the one underlined in (59).

(59) It would have been pointed out by John if there had been any danger.

The formulation of subject replacement in terms of co-referential indices prevents subject replacement from applying to the underlined S's in (60).

(60) The government's action wasn't surprising, but it persuaded John that the president wasn't lying.  
That observation is interesting, but it doesn't prove that we should abandon our efforts.

A third rule in the grammar of English besides it deletion and subject replacement (as they are formulated here) which is stated in terms of co-referential indices is the Equi-NP deletion rule, also discussed in Rosenbaum (1967).

There is a further condition on subject replacement which it is appropriate to discuss here. The rule is obligatory when a verb has both a subject complement and an object or oblique complement, as in (61).

- (61) That John has blood on his hands proves that Mary is innocent.  
 \*It proves that Mary is innocent that John has blood on his hands.

To see that movie is to relive the past.  
 \*It is to relive the past to see that movie.

That John was late persuaded me that the train was delayed.  
 \*It persuaded me that the train was delayed that John was late.

In fact, when such a verb is in a non-root S (which means subject replacement is impossible), there is no way to obtain grammaticality without resorting to paraphrase.

- (62) \*The decision that (that) John has blood on his hands proves that Mary is innocent is ridiculous.  
 \*The decision that it proves that Mary is innocent that John has blood on his hands is ridiculous.  
 Cf. The decision that John's having blood on his hands proves that Mary is innocent is ridiculous.

I will now show how the ungrammatical examples in (61) are a natural consequence of other factors in the grammar, and not of a special condition on subject replacement. In the discussion of passive noun phrases in section II.6, I introduced the concept of a "doubly-filled node" in deep structure, whereby two constituents of the same category can occupy one phrase structure position, as in (63), provided that only one such constituent is present at the level of surface structure.

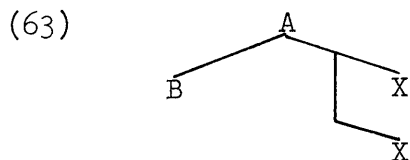

For verbs like prove, mean, imply, be, persuade, convince, show, etc., as exemplified in (61), my analysis requires that I assume a deep structure (64), which is a special case of (63). (The indices of the two embedded

S's in (64) are assigned arbitrarily.)

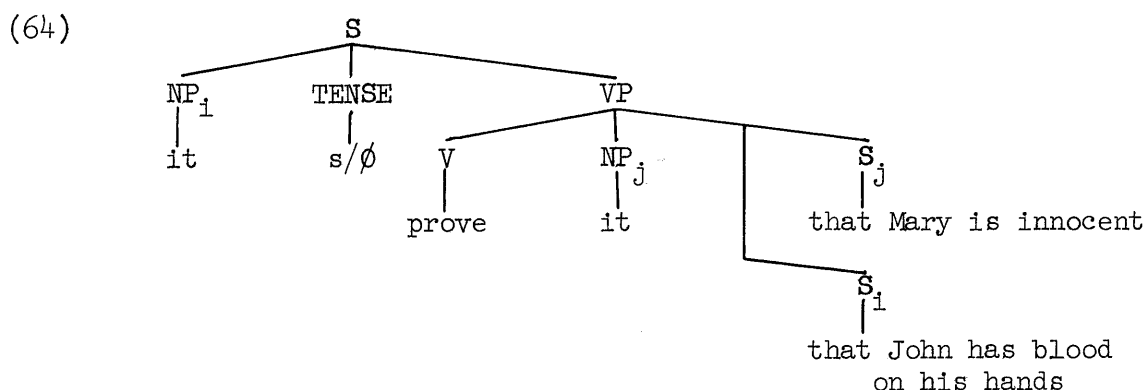

The fact that subject replacement (58) is formulated in terms of co-referential indices means that  $S_1$  in (64) may move to the position of  $NP_1$  in a root S. The fact that a doubly-filled node is never permitted in surface structure means that  $S_1$  must so move. This explains the ungrammaticality of the starred examples in (61) and (62).

III.2.2 Rosenbaum's Verb Phrase Complements Rosenbaum noted that some verbs which take object clause complements appear in the passive, as in (65), and that some do not, as in (66).

(65) That the house was old was denied by John.  
It was denied by John that the house was old.

To remain silent was preferred by John.  
It was preferred by John to remain silent.

(66) \*To buy the Times would be 

tended
started
continued
condescended
hesitated
hastened
failed

 by many of my friends.

(66) (cont.)

\*It would be  $\left. \begin{array}{l} \text{tended} \\ \text{started} \\ \text{continued} \\ \text{condescended} \\ \text{hesitated} \\ \text{hastened} \\ \text{failed} \end{array} \right\}$  by many of my friends to buy  
the Times.

\*That he could pass without trying was  $\left\{ \begin{array}{l} \text{guessed} \\ \text{quipped} \end{array} \right\}$  by John.

\*It was  $\left\{ \begin{array}{l} \text{guessed} \\ \text{quipped} \end{array} \right\}$  by John that he could pass without trying.

\*Sobbing mournfully was  $\left. \begin{array}{l} \text{began} \\ \text{started} \\ \text{kept} \\ \text{resumed} \\ \text{continued} \\ \text{ceased} \\ \text{stopped} \end{array} \right\}$  by John.

\*It was  $\left. \begin{array}{l} \text{began} \\ \text{started} \\ \text{kept} \\ \text{resumed} \\ \text{continued} \\ \text{ceased} \\ \text{stopped} \end{array} \right\}$  by John sobbing mournfully.

Rosenbaum attributed this difference to the difference between the underlying structures (67) and (68). (In this section, I omit writing out deep structure NP's deleted by Equi-NP deletion.)

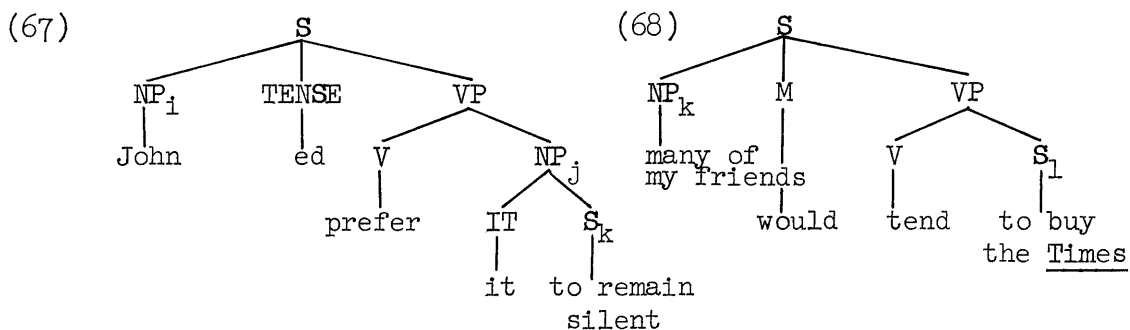

In my analysis of complementation, (67) is replaced by (69), as discussed in the preceding section. However, I retain Rosenbaum's structure (68) for the complements of the verbs in (66) without modification. Thus, I attribute the difference between (65) and (66) to the difference between the underlying structures (69) and (68).

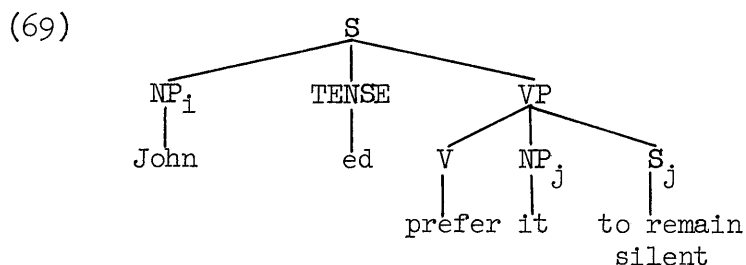

In either mine or Rosenbaum's analysis, NP preposing cannot apply to (68) because there is no NP following the main verb. This accounts for the examples in (66).

Similarly, wh fronting cannot apply to the non-existent object NP in (68). (There are, however, some verbs which appear in the structure (68) which alternatively take object NP's, such as start. These do of course appear in sentences with wh fronted object NP's.)

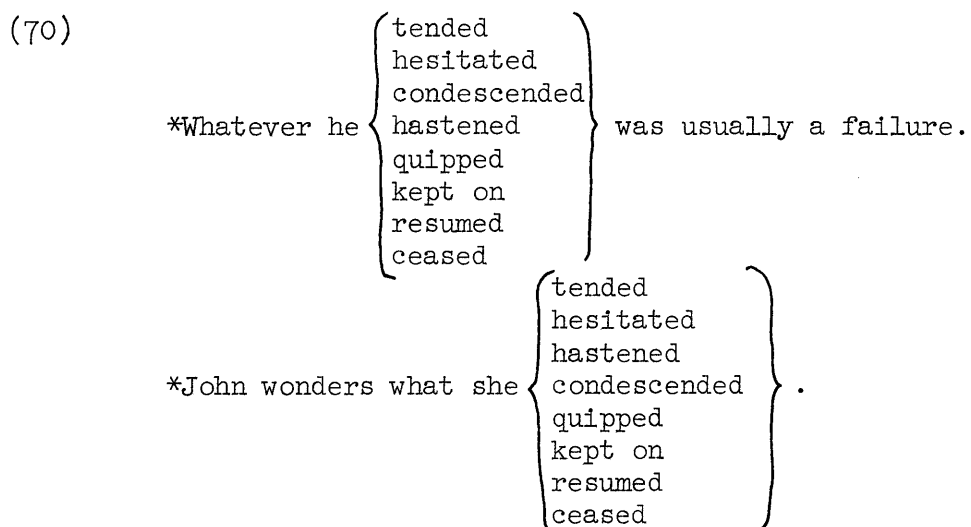

In connection with the impossibility of applying wh fronting to a (non-existent) object NP in structures like (68), it is appropriate to comment on Rosenbaum's conclusions about the pseudo-cleft construction vis-à-vis the non-appearance of the verbs in (66) in the left-hand-side sentences of these constructions.

- (71)
- \*Under pressure, what I  $\left. \begin{array}{l} \text{tend} \\ \text{start} \\ \text{continue} \\ \text{condescend} \\ \text{hesitate} \\ \text{hasten} \\ \text{fail} \end{array} \right\}$  (to) is to visit my psychiatrist.
- \*What John  $\left\{ \begin{array}{l} \text{guessed} \\ \text{quipped} \end{array} \right\}$  was that he could pass without trying.
- \*What she  $\left\{ \begin{array}{l} \text{began} \\ \text{started} \\ \text{kept} \\ \text{continued} \\ \text{resumed} \\ \text{ceased} \\ \text{stopped} \end{array} \right\}$  was sobbing mournfully.

It seems to me that Rosenbaum applied a faulty argument to data like (71) and yet came to the right conclusion. Rosenbaum assumed that the ungrammaticality of the examples in (71) was due to the fact that only NP's could appear to the right of the main copula in the pseudo-cleft construction (i.e., in "focus" position). But this assumption obliterates the well-motivated distinctions among the phrase nodes NP, AP, PP, VP, and S. In particular, the fact that just NP's and PP's appear in focus position in the cleft construction (discussed in section III.1) could not be stated if this assumption were accepted.

The examples of (72) show that the opposite of Rosenbaum's assumption holds: any of the five major phrase nodes can appear in focus position in the pseudo-cleft construction:

- (72)
- What I dislike is custard pie. (NP)
- What we counted on was getting a tax break. (NP)
- What John is is very brave. (AP)
- What Bill seems is quite dishonest. (AP)
- What upsets me is for her to be late. (S)
- What you don't realize is that John is cheating. (S)
- What you should do is blow up some buildings. (VP)
- What John is doing is kicking me in the shins. (VP)
- Where he rolled was down the hill. (PP)

The limitations on what can appear in focus position in the pseudo-cleft constructions are due almost entirely to limitations on what wh words can occur in the "headless relative" S on the left side of the copula. In the most restricted dialect, only what can so appear (meaning that the last example in (72) is ungrammatical). In my dialect, what, where, and when can so appear; in still another, I understand that any wh word can so appear, as in (73).

- (73)       ?How I came was by boat.  
               ?Why John left was because he had a cold.  
               ?Who Mary likes is John.

In spite of his misleading assumption about the nature of the focus constituent in pseudo-cleft constructions, the structure assigned by Rosenbaum to the verbs appearing in (71) can account for the ungrammaticality in (71) adequately. According to him, a typical verb in (71) appears in the following basic structure:

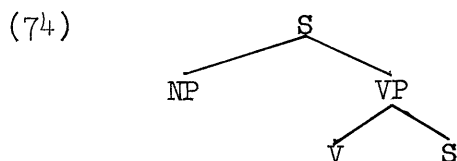

Now suppose the pseudo-cleft construction is formed by deleting the second X-Y (under identity with the first X-Y) in (75), where C stands for the focus constituent.

- (75)       [<sub>S</sub> X - W - Y ] - TENSE - be - [<sub>S</sub> X - C - Y ]

It is clear that W must be able to dominate wh if a pseudo-cleft is to be formed from (75). But suppose that the sentence X-C-Y is "I condescended to visit my psychiatrist," and the pseudo-cleft sentence to be formed has

as its focus constituent the VP "to visit my psychiatrist." (I differ from Rosenbaum in that it is perfectly permissible in my analysis for a VP to be the focus constituent.) This means that in (75),  $X = \underline{I}$  condescended and  $Y = \emptyset$ . But W cannot then be an NP dominating what, since condescend only appears in the configuration (74); thus, \*What I condescended was to visit my psychiatrist" is impossible. (On the other hand, W may be the VP "to do wh-something", so as to yield "What I condescended to do was to visit my psychiatrist.")

A similar argument can be constructed if one assumes the pseudo-cleft is formed by moving a constituent out of a "headless relative" S subject into focus position, leaving behind a wh in an appropriate position. Whatever the analysis of the pseudo-cleft one adopts, the basic point about verbs whose S complements are not antecedents to a subject or object it (i.e., the verbs under consideration in this section) is that the lack of an object NP makes it impossible for wh fronting to apply to produce the pseudo-cleft sentences of (71). These sentences are not excluded because of any limitation on the type of constituent that may appear in focus position in the pseudo-cleft construction.

There remains one further improvement I believe can be made on Rosenbaum's analysis of complementation in terms of the concepts developed in this chapter. Suppose we call the sentence and infinitive complements which are antecedents to a deep structure it "antecedent complements" (these correspond to Rosenbaum's "noun phrase complements") and those which are not, "oblique complements" (these correspond to Rosenbaum's "verb phrase complements"). An interesting question is whether the S complements underlined in (76) are antecedent complements or oblique complements.



- (76) It seems to John that we ought to leave.  
 It happens that I am out of money.  
 It appeared to him that the train had left.

If these complements are antecedents to the subject it, as seems apparent on first glance, then we would expect that subject replacement could operate, as in (77), but it can not.

- (77) \*That we ought to leave seems to me.  
 \*That I am out of money happens.  
 \*That the train had left appeared to him.

We could account for this by assuming that in fact the verbs seem, appear, and happen (in one of its senses) do not take subjects; i.e., that the subject NP's of these verbs are empty in deep structure and that their S complements are oblique complements. (By contrast, the subject NP of predicates like show, irritate, be necessary, be a lie, etc., is a deep structure it if they have a subject complement clause.) Since the subject replacement rule is formulated in terms of co-referential indices, it will not operate if a subject NP is empty.

The source of the it surface subject for seem, appear, and happen would then be the same rule that provides the dummy subject of verbs like rain, snow, etc.

Confirmation of the claim that the subject of seem, appear, and happen is empty in deep structure is given by the fact that, for the senses of these verbs in question, this subject cannot be questioned, as shown in (78). This is behavior which is typical of oblique complements, as we have seen above.

- (78) \*What seems to John?  
 \*What happens?  
 \*What appeared to him?
- \*What seemed to John was that the food was stale.  
 \*What happens is that I don't have any money.  
 \*What appeared to him was that the train had left.

The predicates seem and appear should not be confused with the predicates seem-AP and appear-AP. The latter construction is derived from the former by means of the subject raising rule discussed in section II.4, according to the following sequence of steps (TENSE omitted):

- (79) Deep structure string: Empty NP - seem - that  $it_1$  be A that  $S_1$ .  
 Subject raising:  $It_1$  - seem - be A that  $S_1$ .  
Be deletion:  $It_1$  - seem - A that  $S_1$ .

According to this analysis, the derived predicates seem-(to be)-AP and appear-(to be)-AP have antecedent, not oblique, complements. That is, the complement S's at the end of the VP are co-referential in the derived predicates with the subject it. This is confirmed by the fact that such subjects can be questioned and removed by subject replacement.

- (80) What seems to you to be strange?  
 What appeared interesting?
- What seems strange is that John has left.  
 What appears to be obvious is that Mary is guilty.
- That John has already left seems strange.  
 That we buy these books appears to be necessary.  
 For us to understand this would seem to me to be important.  
 To finish the assignment appeared useless at the time.

In summary, my antecedent complements correspond exactly to Rosenbaum's sentence and infinitive (not gerund) noun phrase complements.

The only exception to this is that I analyze the sentence complements to seem, appear, and happen (in one of its senses) as oblique (i.e., "verb phrase") complements.

Conclusion to Chapter III The main result of this chapter is the conclusion that sentences introduced by that and infinitives are never noun phrases, but are rather S (and perhaps VP) complements generated at the end of VP's, AP's, and NP's. This has been established in large part by the realization that the inverse of Rosenbaum's (1967) extraposition rule has all the properties of a root transformation. Introduction of this rule ("subject replacement") eliminates several irregularities and deficiencies in Rosenbaum's analysis of complementation. The subject replacement rule should therefore be added to the list of other root transformations compiled in Chapter I, and should replace Rosenbaum's extraposition rule.

## CHAPTER IV: EXTENDING THE STRUCTURE-PRESERVING CONSTRAINT

A structure-preserving constraint on movement transformations was proposed in Chapter II, and it was shown that most NP movement rules of English which apply in embedded sentences are subject to this constraint. In this chapter, I will show how the structure-preserving constraint applies to movements of other phrase nodes besides NP's.

IV.1 Adjective Phrase Movement Rules By "adjective phrase" (AP) I mean the constituent whose head is an adjective and which also dominates any of the modifiers characteristic of adjectives (very, so, how, too, more, most, measure phrases like five miles, other adjectives like tremendously, slowly, etc.) and the PP and S complements of adjectives.

One important rule which moves AP's is the wh fronting rule. Some examples of constituents which it moves to the front of an S are given in (1). However, I will not discuss wh fronting in this section, since this rule and its effects are taken up in section IV.4.

- (1) How does the patient seem today?  
How quickly did he finish the boat?  
How capable do you consider him?  
How long a chapter should he write?  
John wondered how important it was to return on time.  
How brave he became when he was safe at home!  
I don't want to go with you, no matter how slow you go.  
I don't want to go with you, however slow you go.

(The wh word in the modifier of the AP, how, can stand alone in questions just as the wh words in the determiner of an NP can: "What did he buy?")

IV.1.1 Adjective Movement In general, nouns can be modified by a following VP introduced by ing, as in (2). These VP's are called

participles. As (2a) and (2c) show, this ing is not simply a reduced form of the progressive morpheme pair be-ing.

- (2) (a) We picked up a box containing some books.  
Cf.\*The box was containing some books.
- (b) The workers burning the boxes were sweating.
- (c) The students having seen this movie should let us know.  
Cf.\*The students were having seen this movie.

However, not any VP (i.e., not any sequence of verbs excluding TENSE and modals which can appear in sentences) can modify a noun in this way:

- (3) (a) \*We were speaking to a man being very jealous of his father.  
(VP = ing + be very jealous of his father)
- (b) \*I loaned him a book being important for his studies.  
(VP = ing + be important for his studies)
- (c) \*The books being contained in the box were worthless.  
(VP = ing + be contained in the box)
- (d) \*The boxes being being burned at the dump are foul-smelling.  
(VP = ing + be being burned at the dump)
- (e) \*The boxes being burning at the dump are foul-smelling.  
(VP = ing + be burning at the dump)
- (f) \*The person being being kindest to me was my aunt.  
(VP = ing + be being kindest to me)

Instead of the ungrammatical sequences of (3), we find a corresponding set of grammatical sentences (4). Each example of (4) can be obtained from (3) by deleting the first being underlined in each example of (3).

- (4) (a) We were speaking to a man very jealous of his father.  
(b) I loaned him a book important for his studies.  
(c) The books contained in the box were worthless.  
(d) The boxes being burned at the dump are foul-smelling.  
(e) The boxes burning at the dump are foul-smelling.  
(f) The person being kindest to me was my aunt.

I assume, therefore, that the initial being in a participle which is a sister to a head noun is deleted. According to this analysis, (2b) and (4e) are ambiguous, being derivable from an underlying participle which may or may not be in the progressive form. On the other hand, (4d) and (4f) can have only an underlying progressive source, since an underlying ing + be + en + burn would become simply burned. This is confirmed by the fact that verbs which cannot appear with the progressive auxiliary in full sentences are also excluded in sentences like (4d) and (4f):

- (5)       \*The books being contained in the box are worthless.  
           \*The person being most important to me was my aunt.

Thus, in this type of participle, the progressive-simple form alternation appears in surface structure only in the passive voice.

The rule of being deletion which derives (4) means that AP's can sometimes immediately follow nouns inside NP's, as in (4a) and (4b) above. It is well-known, however, that AP's derived from participles by being deletion which end in an A (i.e., they contain no PP or S complements, as do (4a) and (4b)) precede rather than follow the nouns they modify in surface structure. Compare the pairs in (6):

- (6)       \*We were speaking to a man very jealous.  
           We were speaking to a very jealous man.
- \*The tourists anxious boarded the bus.  
           The anxious tourists boarded the bus.
- \*I loaned him a book important.  
           I loaned him an important book.
- \*The possibility of a decision crucial being made is minimal.  
           The possibility of a crucial decision being made is minimal.

Similarly, it appears that certain participles can also move over the

nouns they modify. (The VP's which move must, like AP's, end in their head.)

- (7)        The quietly sleeping children shouldn't be disturbed.  
               This often retold story is now being made into a movie.

To account for the position of adjectives in (6), Smith (1961) proposed an "adjective movement" rule which would derive the grammatical strings in (6) from structures underlying the strings of the corresponding starred examples. If we want this rule to account for the sentences of (7) also, it should be formulated as a VP movement rule. (There are restrictions, in this case, on just which VP's can move: cf. "\*The stopping cars are mostly old" vs. "The cars stopping are mostly old.") If the AP's derived from underlying participles (VP's) by being deletion are still dominated by VP when "adjective movement" applies, this rule has roughly the form (8):

$$(8) \quad X - N - VP - Y \Rightarrow 1 - 3 + 2 - \emptyset - 4$$

where 1-2-3-4 is an NP  
of which 2 is the head,  
and where the head of 3  
is rightmost in 3.

It is well-known that adjective movement does not move constituents over composite pronouns like nobody, everything, someone, someplace, etc. I think this can be explained by analyzing these pronouns as DET's rather than N's, at least when rule (8) applies. Independent justification for this is that these pronouns are formed from the determiners no, some, every, and any, and these morphemes retain their syntactic characteristics in the composite forms. For example, the some-any distribution in negative contexts carries over to something-anything, etc., and the

composite forms of every are definite just as every is. These facts mean that composite pronouns are dominated either by a single pre-terminal symbol DET or by the sequence of such symbols DET-N. But the fact that these pronouns are spelled as single words and that their second element must be unstressed, unlike other DET-N sequences (each boy, that thing, any body, etc.) indicates that they are single morphemes in surface structure, i.e., instances of DET. (Further, the form -body in composite pronouns does not have the syntactic characteristic -ANIMATE of the noun body.)

The noun-modifying participles that I have been describing (including the adjective phrases derived from them) are generally synonymous with relative clauses whose subject is a relative pronoun and which have no modal (M). Thus, these participles are probably derived transformationally from relative clauses by deletion of [NP who] - TENSE and insertion of ing. (Another possibility is that the projection rules which interpret the two noun-modifying clause constructions, participles and relative clauses, have the same output.)

It seems unlikely, however, that all adjectives which appear in pre-nominal position in surface structure can be derived from an underlying participle or relative clause. In the first example of (9), for example, the second clause has one meaning (in fact, the principal meaning in the context) which is not paraphrasable by a relative clause like "she is a bridge-player who is eager." This clause rather has the meaning "she is eager to play bridge."



- (9) Mary is quite retiring, but she is an eager bridge-player.  
 A good track man should be a slow eater.  
 John scolded the most willing hikers for not co-operating in  
 other matters.  
 John is a frequent caller.  
 A likely early leader is now approaching the starting gate.

Similar remarks apply to the other examples in (9).

(10a) cannot be paraphrased (in one of its senses, at least) as "students are the revolutionaries who are traditional"; rather, it means "students are traditionally the revolutionaries." In (10b), "three possible suspects" should not be derived from "\*three suspects who are possible." The adjectives in (11) cannot appear as predicate attributes (although four of them do appear as adverbs in ly), so it is unlikely that they are derived from underlying relative clauses.

- (10) (a) Students are the traditional revolutionaries in that country.  
 (b) They have arrested three possible suspects.
- (11) Potential criminals are hard to detect.  
 Don't overestimate the actual importance of the election.  
 The main purpose of these assignments has never been made known.  
 We witnessed an utter failure.  
 Chasing butterflies is his favorite pasttime.

In (12), the pre-nominal adjectives have meanings that are seemingly related to the usual (predicate attribute) meanings of these adjectives. On the other hand, these meanings of the adjectives in question cannot be directly derived from relative clauses.

- (12) The poor man has more money than he can handle.  
 ≠ The man who is poor has more money than he can handle.
- My little sister weighs 200 pounds.  
 ≠ My sister who is little weighs 200 pounds.
- He is one of my oldest friends.  
 ≠ He is one of my friends who is oldest.

(12) (cont.)

- Do you have any later word on that flight?  
 ≠ Do you have any word on that flight which is later?

Faced with several kinds of pre-nominal adjectives which cannot be derived from relative clauses in a straightforward way, I conclude that adjective movement presents no definite evidence for or against the structure-preserving constraint. The reasoning is as follows:

If all pre-nominal adjectives could be shown on independent grounds to be derived from an underlying (not necessarily deep structure) post-nominal source, such as relative clauses, so that it was known that a rule like (8) is the only source for pre-nominal adjectives, then (8) could not be a structure-preserving rule. But such a demonstration seems quite problematic at this time.

However, even in this case, adjective movement, like dative movement, satisfies the definition of a minor movement rule which will be given in Chapter V. Although I am trying to defend the stronger position that phrase-node movement rules are always structure-preserving, we will see in Chapter V that a limitation of movement rules to the structure-preserving and minor movement rule class would still be a strong empirical (though perhaps less elegant) constraint on transformations. It is important to emphasize that the two phrase node movement rules whose structure-preserving status seems doubtful (dative movement and adjective movement) are the only phrase node movement rules which will satisfy the definition of minor movement rules to be given in Chapter V.

On the other hand, if it could be shown that one of the classes of pre-nominal adjectives in (9) through (12) is pre-nominal in deep structure, then adjective movement would be definite evidence in favor of the structure-preserving constraint. On the assumption that deep structures

are the same as surface structures unless we have some convincing argument to the contrary, some or all of the classes of adjectives in (9) through (12) are pre-nominal in deep structure, and (8), at least as far as AP's are concerned, is structure-preserving. But this is only a temporary position since it is possible that arguments for post-nominal sources of the adjectives in question will be discovered.

An important observation about the adjective movement rule (8) is that this formulation, whether or not it is structure-preserving, does not explain in any way the condition the pre-nominal AP's (and VP's) must end in their head, or else the rule does not apply. There is a different line of reasoning which would both explain this condition and which would involve only structure-preserving rules, but which involves certain other difficulties and assumptions which I will not try to deal with fully here. Rather, I will limit myself to sketching the possible analyses which might follow from it.

For different reasons, Smith (1964) and Jackendoff (1968) have argued that relative clauses should originate in pre-nominal position. (Whether they should originate under DET or as a sister to DET I take no stand on here.) If we take this position, we must replace adjective movement (8) with a "relative postposition" rule which applies either to a full sentence relative (S) or a reduced participial relative (VP), roughly as in (12a).

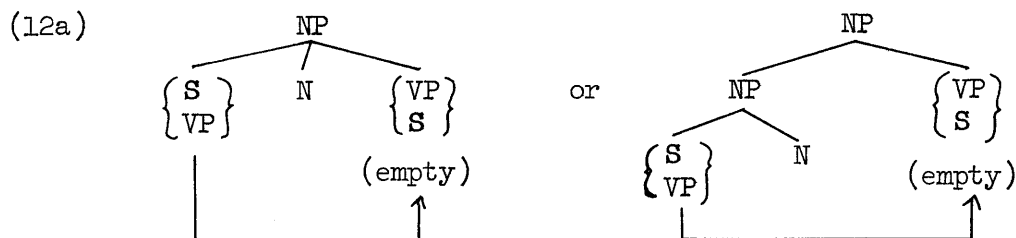

It seems plausible to assume that the phrase structure rules could be written to provide empty S and VP nodes for such a rule in a non ad hoc way.

If this is possible, an explanation for why adjectives without PP or S complements do not appear in post-nominal position seems available. Such complements to adjectives appear in very few AP positions. In particular, ly adverbs with such complements (underlined in (12b)) are excluded.

- (12b) \*John politely to the girls answered.  
 \*The crowd was milling about anxiously to board the bus.  
 \*John eagerly to please brought us our coats.

(In the parentheticals especially to me, certainly in this case, etc., the adverbs probably modify the PP rather than vice-versa.) To explain this, one might propose that AP's only dominate DEG-A sequences, and that PP and S complements to predicate adjectives are immediately dominated by VP. (This raises questions with wh fronting which I will not try to answer here.) Now, if one makes the further assumption that non-branching phrase nodes without heads are pruned, the rule of being deletion in a participle dominating a predicate but no PP or S complement causes the loss of the VP node, as in (12c).

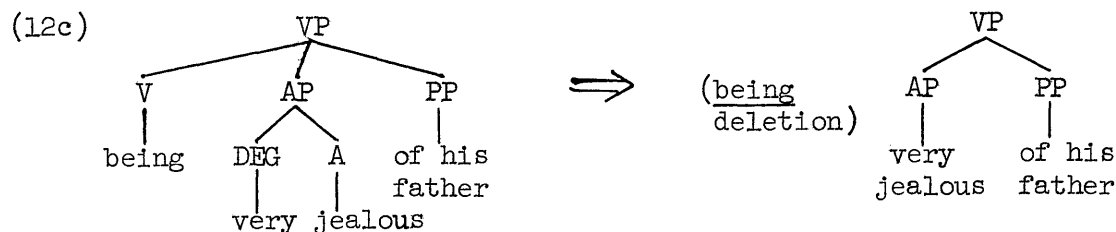

(12c) (cont.)

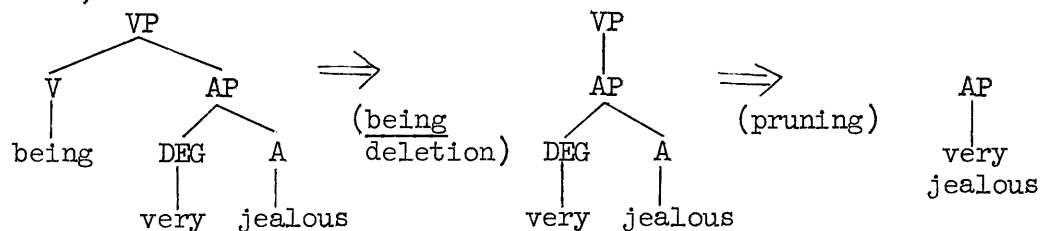

In this way, if the relative postposition rule (12a) is formulated as a rule moving VP's and S's, the fact that adjectives without complements may not be postposed is automatically explained. (Still unexplained is why some, but not all, participles which end in V are optionally postposed. But this difference is unexplained in the adjective movement rule formulation also.)

A somewhat different analysis might proceed from the same original assumption that relative clauses and participles are in pre-nominal position in underlying structure. However, we now generate PP and S complements under AP's. We next assume that "relative postposition" is a structure-preserving rule which actually applies to the PP or S complements inside AP's like very jealous of his father, polite to girls, ready to board the bus, as in (12d).

(12d)

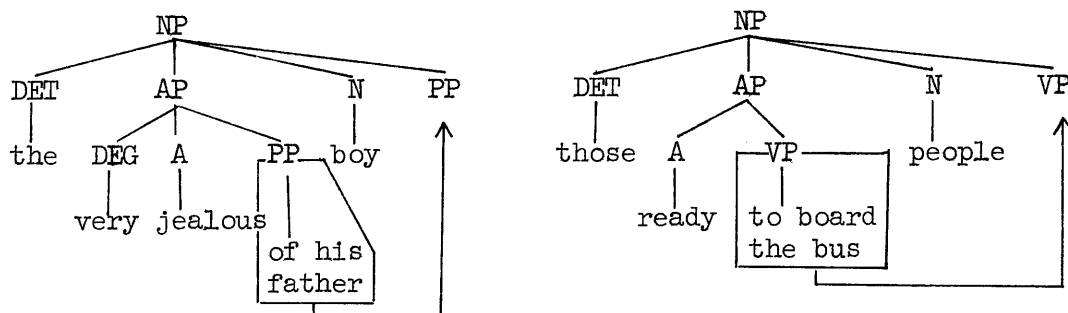

It would again follow that relative postposition, this time formulated as a movement of S, VP, or PP, could not apply to an AP without an S, VP, or PP complement. In this case, however, we would have to explain why

the entire AP, and not just the S, VP, or PP complement it dominates, is placed in post-nominal position. Such an explanation would have to be along the lines suggested in section IV.5 for the "complex NP shift rule." In complex NP shift, an S is moved in structure-preserving fashion, but the NP which immediately dominates it moves along with the S. That is, NP is related to S in the complex NP shift rule as AP is related to S, VP, or PP in the formulation of relative postposition being discussed here. However, since I am not able at this point to define the exact conditions under which a larger constituent can be moved along with one it dominates, this solution also remains problematic.

A structure-preserving formulation of adjective phrase movement along one of the two lines suggested here, starting from the assumption that relative clauses (and other AP's) have a pre-nominal source in deep structure, may therefore hold the key to an insightful explanation of the as yet unexplained condition on adjective phrase movement, the condition that prenominal adjective phrases must end in their head and that post-nominal adjective phrases may not.

IV.1.2 Adverbial Adjective Phrases In this section, the positions of adverbial AP's (i.e., AP's whose head ends in the suffix ly) will be discussed vis-à-vis the structure-preserving constraint. We cannot, at the outset, focus our attention on specific adverbial AP movement rules, since there has been no general acceptance by transformationalists of any particular formulation of such rules, even though there is general agreement that such rules exist. Nor have transformationalists been able to agree on the source in the base for adverbial AP's of various sorts.

Because of the uncertainties involved in an analysis of adverbial

AP's, I will restrict the discussion to the placement and meaning of these constituents in declarative clauses with finite verbs, in the hope that my conclusions can be extended so as to be valid in non-finite clauses (infinitives, gerunds, participles, imperatives, and questions) as well.

It is well-known that ly adverbials can appear in finite clauses in several positions. For example, in (13), the adverbs in parentheses by each example can appear in any of the blanks.

- (13)
- \_\_\_\_\_, John \_\_\_\_\_ could \_\_\_\_\_ have ?? been there by six.  
 (probably)
- \_\_\_\_\_, John \_\_\_\_\_ has ?? been \_\_\_\_\_ answering questions \_\_\_\_\_  
 for an hour \_\_\_\_\_. (oddly)
- John has ?? been \_\_\_\_\_ answering questions \_\_\_\_\_ for an  
 hour \_\_\_\_\_. (nervously)
- \_\_\_\_\_, John \_\_\_\_\_ has \_\_\_\_\_ been ?? answering questions  
 for an hour. (evidently)
- John has \_\_\_\_\_ been \_\_\_\_\_ answering questions for an hour.  
 (merely)

At first, this apparent freedom of occurrence seems to indicate that English adverbial AP's are not subject to the structure-preserving constraint. However, care must be taken in distinguishing what constitutes evidence against this constraint. If a constituent X appears in two surface structure positions, P and P', with the same meanings (except perhaps for differences due to the different roles X might play in the two positions with regard to surface structure rules of interpretation), this is evidence against the structure-preserving constraint. For in this case, either position, say P, can be taken as the deep structure position of X. Semantic projection rules then associate this position with appropriate meanings, and a non-structure-preserving transformation T moves X from P to P'.

In this case, in order to avoid a non-structure-preserving transformation, either X must be generated in both P and P' in deep structure, in which case two sets of projection rules operating on X, each yielding the same meanings, must be written for P and P', or else an X which is always empty must be generated in P' by the phrase structure rules only for the (ad hoc) purpose of making T structure-preserving. In either case, the generalization captured by a non-structure-preserving transformation would be lost.

(If the same projection rules can interpret X in P and in P' without recourse to additional symbols, the evidence against the structure-preserving constraint disappears, for there is no objection to accounting for distribution alone by phrase structure rules rather than transformations.)

However, assuming that the set of meanings of X common to both P and P' is M, suppose that in at least one position, say P', X has a further set of meanings M'. (Evidence for this in a particular case might be ambiguities of X in P', a wider range of lexical entries for X in P', etc.) An obvious way to account for the discrepancy would be to associate the deep structure position P' with projection rules yielding the meanings M' for X, and to associate P with projection rules yielding M for X. The transformation T, which moves X from P to P', is now positive evidence for the structure-preserving constraint rather than evidence against it, since one needs an explanation of why T moves X to another deep structure position of X and not to some arbitrary position. (Of course, the existence of one or two rules in the grammar of this sort could be an accident, but I am trying to show that all non-root transformations in English which are not minor movement rules have this property.)



I will try to show in this section that adverbial AP's in English exhibit the behavior described in the last paragraph, and hence are actually evidence for the structure-preserving constraint. Consider now the bracketed adverbs in (14).

- (14)
- John answered the questions  $\left\{ \begin{array}{l} \text{intelligently} \\ \text{with intelligence} \\ \text{in an intelligent way} \end{array} \right\}$  .
- They called  $\left\{ \begin{array}{l} \text{loudly} \\ \text{in a loud manner} \end{array} \right\}$  through the halls.
- They called through the halls  $\left\{ \begin{array}{l} \text{loudly} \\ \text{in a loud manner.} \end{array} \right\}$  .
- He puts his books away  $\left\{ \begin{array}{l} \text{carefully} \\ \text{with care} \\ \text{in a careful way} \end{array} \right\}$  in the drawer.
- He puts his books away in the drawer  $\left\{ \begin{array}{l} \text{carefully} \\ \text{with care} \\ \text{in a careful way} \end{array} \right\}$  .
- He uses symbols in his explanations  $\left\{ \begin{array}{l} \text{understandably} \\ \text{in understandable fashion} \end{array} \right\}$  .
- He uses symbols  $\left\{ \begin{array}{l} \text{understandably} \\ \text{in understandable fashion} \end{array} \right\}$  in his explanations.
- China has industrialized  $\left\{ \begin{array}{l} \text{rapidly} \\ \text{in rapid fashion} \end{array} \right\}$  .
- The rain is cleaning our car  $\left\{ \begin{array}{l} \text{thoroughly} \\ \text{in thorough fashion} \end{array} \right\}$  .
- John took the wallpaper off  $\left\{ \begin{array}{l} \text{efficiently} \\ \text{in an efficient manner} \end{array} \right\}$  first.

Adverbial AP's which can be paraphrased as in (14) are manner adverbials. For purposes of exposition, I assume here that an adverbial AP which follows and modifies a verb V without an intervening breath pause (comma) is a sister to that V. This position will be slightly modified in section IV.3, but not in any way crucial to the discussion here. (Adverbial adjectives in phrases like barely on time and hardly a dozen people are not sister constituents to verbs even when they follow them, but they do not modify the preceding verbs either; they rather are part

of the constituents PP and NP.)

Most of the adverbial AP's which follow a verb as a sister constituent to the verb are manner adverbials. In some cases, the PP paraphrases for these adverbials, of the kind given in (14), are clumsy and even ungrammatical. But if such PP paraphrases do not distort the meaning of the adverbial AP, I will assume the adverbial in question is a manner adverbial. Examples of this kind are given in (15); nothing in what follows strictly depends on enlarging the manner adverbial class in this way.

- (15) This business has failed completely.  
 Ungrammatical, but similarly interpreted:  
 \*This business has failed in a complete way.
- The sun is shining dimly through the clouds.  
 Ungrammatical, but similarly interpreted:  
 \*The sun is shining in dim fashion through the clouds.

The adverbial AP's which follow a verb but are preceded by a comma can be shown to be derived by means of a root transformation; hence, they are immediately dominated by S, not by VP. This root transformation is similar to the "right dislocation" rule which moves NP's out of sentences to the right (cf. section I.9), so I will call this rule "adverbial dislocation." The adverbials which undergo this rule are not manner adverbials, but rather factive adverbials. The deep structure source of these adverbials is discussed later in this section.

Examples of dislocated adverbials are given in (16), along with paraphrases.

- (16) We aren't doing our share, actually.  
We aren't actually doing our share.
- That man could have been replaced, possibly.  
That man could possibly have been replaced.
- John sneaked away in time, evidently.  
John evidently sneaked away in time.
- John didn't answer any questions, wisely.  
John wisely didn't answer any questions.
- John won't co-operate, supposedly.  
John supposedly won't co-operate.
- Bill took the wrong turn, fortunately.  
Bill fortunately took the wrong turn.

The examples of (17) show that adverbial dislocation is a root transformation, since an adverbial AP cannot apparently be "dislocated" out of an embedded S which is not rightmost under a root S.

- (17) \*Her accusation that we aren't doing our share, actually,  
is groundless.  
Her accusation that we aren't actually doing our share is  
groundless.
- \*They gave the only man that could have been replaced, possibly,  
a tenured position.  
They gave the only man that could have possibly been replaced  
a tenured position.
- ?Even though John sneaked away in ~~time~~, evidently, his wife was  
caught.  
≠Even though John evidently sneaked away in time, his wife was  
caught.
- \*The fact that Mary didn't answer any questions, wisely, allowed  
John to avoid prosecution.  
The fact that Mary wisely didn't answer any questions allowed  
John to avoid prosecution.
- \*The people saying that I don't co-operate as much as John does,  
supposedly, are slanderers.  
The people saying that I don't co-operate as much as John  
supposedly does are slanderers.

(17) (cont.)

\*I think that the fact that Bill took the wrong turn, fortunately,  
saved our lives.

I think that the fact that Bill fortunately took the wrong turn  
saved our lives.

I return now to the question of finding a deep structure source for manner adverbials. Katz and Postal (1964) have suggested that they should be derived from an underlying PP roughly of the form "in a(n) AP way." Such a derivation would accomplish the following: (i) It would account for the meaning of (and certain selectional restrictions on) adverbial AP's without a special projection rule for interpreting the configuration

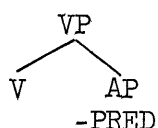

(ii) It would explain why post-verbal manner adverbials

can appear both before and after certain other post-verbal PP's, as in (14), since the PP's of the type they are derived from can also so appear.

(iii) It could utilize a rule needed independently in the grammar for deleting in before an object whose head is way.

(18) John answered the questions (?in) the wrong way on purpose.  
They call through the halls (?in) this loud way to get people up.  
I'll put my books away (?in) any way I want to.  
He used that lemma in his proof (?in) the understandable way.  
Russia industrialized the rapid way.  
John took the wallpaper off (?in) the efficient way first.

Sentences in which this in deletion rule would apply before a(n) are not usually grammatical.

(19) \*John answered the questions a wrong way on purpose.  
\*They call through the halls a loud way to get people up.  
\*I'll put my books away a careful way.  
\*He used that lemma in his proof an understandable way.  
\*Russia industrialized a rapid way.  
\*John took the wallpaper off an efficient way first.

However, we can allow in deletion to apply before a(n) if we subsequently reduce the sentences of (19) to manner adverbial AP's by deleting a(n) and way, as in (20).

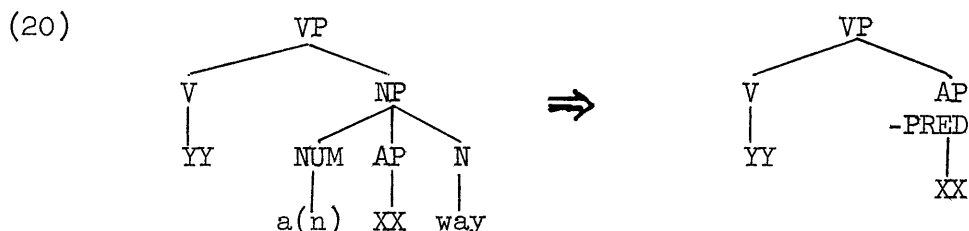

(If the NP node were retained over manner adverbials, they would appear in focus position in cleft sentences, which they do not. This was discussed in section III.1.) The deletion in (20) produces the examples of (21):

- (21)
- John answered the questions wrongly on purpose.
  - They call through the halls loudly to get people up.
  - I'll put my books away carefully.
  - He used that lemma in his proof understandably.
  - Russia industrialized rapidly.
  - John took the wallpaper off efficiently first.

This derivation of manner adverbials is compared with an alternative analysis later in this section.

A manner adverbial often precedes rather than follows the V that it modifies. When manner adverbials appear in this position, they do not always seem to be an exact paraphrase of the post-verbal manner adverbial, but the differences in meaning are slight, and may well be due to surface structure interpretation of what represents the "focus" or "new information" of the sentence. Thus, the following pairs are near paraphrases (even though the second examples may have an alternate sense too).

- (22) John has answered the questions intelligently.  
John has intelligently answered the questions.
- They called through the halls loudly.  
They loudly called through the halls.
- He puts his books away carefully.  
He carefully puts his books away.
- He can use symbols understandably in his explanations.  
He can understandably use symbols in his explanations.
- China has industrialized rapidly.  
China has rapidly industrialized.
- The rain is cleaning our car thoroughly.  
The rain is thoroughly cleaning our car.
- John has taken the wallpaper off efficiently.  
John has efficiently taken the wallpaper off.
- The sun is shining dimly through the clouds.  
The sun is dimly shining through the clouds.
- This business has failed completely.  
This business has completely failed.

Certain manner adverbials do not exhibit this alternation, under conditions which I will not try to specify here.

- (23) We must eat simply in this town.  
≠ We must simply eat in this town.
- John explained that theorem understandably.  
(?)≠ John understandably explained that theorem.

Most manner adverbials cannot, however, precede the auxiliaries or the subject NP. Adverbial AP's in these latter positions have either no meaning or else a non-manner sense in the great majority of cases.

- (24) Intelligently, John has answered the question.  
≠ John has answered the question intelligently.
- ?Carefully, I will put my books away.  
≠ I will put my books away carefully.

(24) (cont.)

\*Thoroughly, the rain cleaned our car.  
 ≠ The rain cleaned our car thoroughly.

Conscientiously, Bill is working under his father.  
 ≠ Bill is working under his father conscientiously.

\*This business completely has failed.  
 ≠ This business has failed completely.

\*The sun dimly is shining through the clouds.  
 ≠ The sun is shining dimly through the clouds.

The government rightly has already acted in this manner.  
 ≠ The government has already acted rightly in this manner.

My lawyer has actually been helping me.  
 ≠\*My lawyer has been helping me actually.

We simply must eat in this town.  
 ≠ We must eat simply in this town.

They nearly were crushed by the throng.  
 ≠\*They were crushed nearly by the throng.

The examples of (24) show that manner adverbials do not have freedom of occurrence in all adverbial positions in the sentence. Rather, they occur in the positions of the PP's of which they are paraphrases and also immediately before the verb they modify. If the source of a manner adverbial AP is a PP, as suggested above, the second sentences in the pairs of (22) must be derived from the first by means of a "manner movement" transformation. This rule would move an adverbial AP sister of a V to a position just preceding that V. Since such a rule would not be a root transformation or a minor movement rule, it would be important to determine if it were structure-preserving or not.

Before we turn to this crucial question, let us see if any alternative analyses of manner adverbials could furnish evidence against the structure-preserving constraint.

If the manner movement transformation were rejected in favor of generating manner adverbials pre-verbally in the base, this would not in itself be evidence against the structure-preserving constraint, for it no movement rule applies to manner adverbials, such constructions obviously provide no evidence for or against any constraint on movement transformations. However, generating manner adverbials in pre-verbal position would entail duplicating the interpretive mechanisms for manner adverbial PP's which follow the verb.

If manner adverbial AP's were generated in the base in pre-verbal position and if a "manner postposing" rule moved such AP's into post-verbal positions, this would be evidence against the structure-preserving constraint. Such a rule would not be a root transformation or a minor movement rule, and it would not be structure-preserving because manner adverbial AP's can appear post-verbally in positions that predicate adjective AP's cannot:

- (25)     John disappeared last night quite abruptly.  
           \*John appeared last night quite abrupt.  
           John appeared quite abrupt last night.
- John answered some questions at the police station impatiently.  
           \*John became at the police station impatient.  
           John became impatient at the police station.

The hypothetical "manner postposing rule" would be formulated roughly as in (26):

$$(26) \quad [{}_{VP} \text{ AP} - X - (\text{PP})^* + (\text{S})] \Rightarrow \emptyset - 2 + 1 - 3$$

(26) has three disadvantages which lead to its rejection. First, such a rule doesn't explain why manner adverbials have PP paraphrases, as in (14). Second, at least two classes of adverbial AP's can appear in pre-verbal



position (these classes are discussed below) which may not appear in post-verbal position. These AP's would have to be prevented from undergoing (26) in ad hoc fashion. (On the other hand, a corresponding restriction on the manner movement preposing rule previously suggested does not arise.) Third, if post-verbal PP's can be reduced to manner adverbial AP's, then (26) is totally redundant. Therefore, if (26) is in the grammar, manner adverbial PP's should not be reduced to AP's by deletion of in and of a(n) way. This in turn means that there is no principled explanation for the discrepancy between the sentences in (18) and (19), juxtaposed here in (27).

- (27) John answered the questions  $\left\{ \begin{array}{l} \text{the wrong way} \\ *a \text{ wrong way} \end{array} \right\}$  on purpose.
- They call through the halls  $\left\{ \begin{array}{l} \text{this loud way} \\ *a \text{ loud way} \end{array} \right\}$  to get people up.
- I'll put my books away  $\left\{ \begin{array}{l} \text{any old way} \\ *a \text{ careful way} \end{array} \right\}$ .
- He used that lemma in his proof  $\left\{ \begin{array}{l} \text{the understandable way} \\ *an \text{ understandable way} \end{array} \right\}$ .
- Russia industrialized  $\left\{ \begin{array}{l} \text{the rapid way} \\ *a \text{ rapid way} \end{array} \right\}$ .
- John took the wallpaper off  $\left\{ \begin{array}{l} \text{the efficient way} \\ *an \text{ efficient way} \end{array} \right\}$  first.

(If manner adverbial AP's are derived from manner adverbial PP's as previously suggested, the starred phrases in (27) are ungrammatical because they are obligatorily transformed into manner adverbial AP's.)

Thus, there are three reasons for rejecting (26) as a transformational rule of English.

If manner movement (from post-verbal PP position to pre-verbal position) is a rule of English, we must determine whether or not it is

structure-preserving. Structurally, manner movement performs the change indicated in (28). The crucial question, given such a rule, is whether there is any justification for generating AP's at the beginning of VP's (in the base) for other constructions besides manner adverbials.

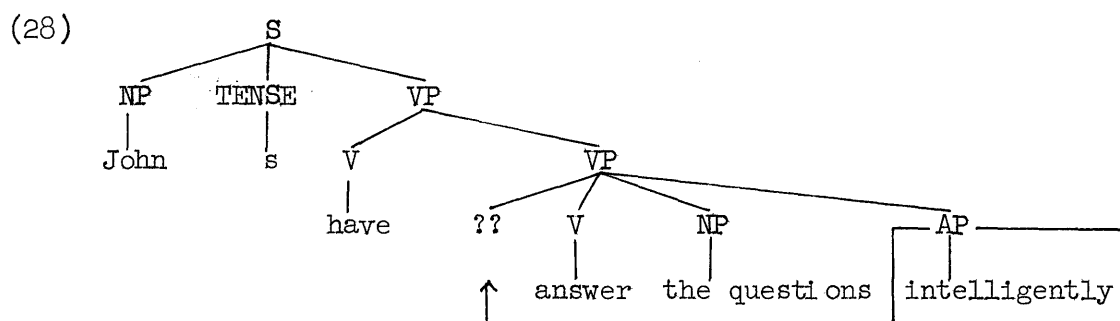

If there is not, then manner movement is evidence against the structure-preserving constraint. If there is, then the rule is evidence in favor of the constraint.

With this in mind, consider the class of adverbs simply, merely, hardly, barely, scarcely, nearly. These adverbs do not follow the V's that they modify and cannot be paraphrased (in the senses we are interested in here) by a PP; thus, a post-verbal source is not appropriate for them. (Of interest later will be the fact that these adverbs cannot precede the subject NP either, except, in some cases, by virtue of the root transformation of negative preposing discussed in Chapter I.) Typically, an adverb of the scarcely class can appear in all (and only) the blanks in an example like (29).

(29) John \_\_\_\_\_ would \_\_\_\_\_ have \_\_\_\_\_ been \_\_\_\_\_ {questioned  
injured} by  
the police.

These adverbs indicate a necessity for a new source of adverbs, such as that given in the modified base rules (30) and (31); if each auxiliary

is the head of a VP, as was shown in section II.2.2, (30) and (31) account for all the positions of scarcely adverbs in (29).

(30) VP  $\rightarrow$  (  $\begin{matrix} \text{AP} \\ \text{-PRED} \end{matrix}$  ) - V - ....

(31) S  $\rightarrow$  COMP - NP - (  $\begin{matrix} \text{AP} \\ \text{-PRED} \end{matrix}$  ) - M - ....

The scarcely class is generable in any of the AP positions given by (30) and (31), as (29) shows. Manner movement, on the other hand, moves manner adverbials only to the AP position immediately preceding the V they modify. Thus, manner adverbials cannot appear in any of the blanks in (32), as can members of the scarcely class.

(32) John \_\_\_\_\_ would \_\_\_\_\_ have \_\_\_\_\_ been questioned by the police.  
           (\*intelligently)  
 He \_\_\_\_\_ could \_\_\_\_\_ have \_\_\_\_\_ been driving his car.  
           (\*cautiously)  
 The building \_\_\_\_\_ was \_\_\_\_\_ being destroyed. (\*completely)

Since adverbs of the scarcely class have a different origin than do manner adverbials, we expect that they will not satisfy the requirement that verbs like phrase and word have manner adverbials.

(33) \*John has  $\left\{ \begin{matrix} \text{merely} \\ \text{barely} \\ \text{nearly} \end{matrix} \right\} \left\{ \begin{matrix} \text{worded} \\ \text{phrased} \end{matrix} \right\}$  the announcement.

With the modification of (30) in the grammar, manner movement is a structure-preserving rule, as shown in (34). It should be re-emphasized that the basis of this argument is the existence of a class of strictly pre-verbal AP's which cannot be analyzed as manner adverbials, and which, contrary to the behavior of the latter, can precede any V, not just a non-auxiliary V.

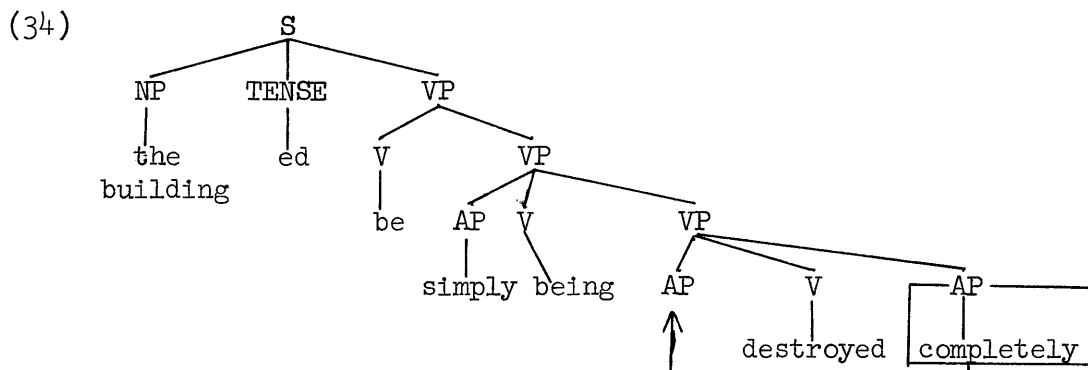

(The building was simply being completely destroyed)

Confirmation of the structure-preserving analysis of manner movement is furnished by the unacceptability of placing a manner adverbial before the V if a member of the scarcely class occupies that position in surface structure. (Evidence on this matter can be obscured by the possibility of manner adverbials themselves being modified by a scarcely class adverb, but the examples in (35) avoid this.)

- (35) John was simply driving his car more cautiously.  
 John was (\*simply) more cautiously driving his car.
- John was merely questioned by the police briefly.  
 John was (\*merely) briefly questioned by the police.
- John merely answered all the questions intelligently and then left.  
 John (\*merely) intelligently answered all the questions and then left.
- She was hardly speaking politely to her parents.  
 She was (\*hardly) politely speaking to her parents.
- She nearly killed her brother accidentally.  
 She (\*nearly) accidentally killed her brother.
- I can barely speak French intelligibly.  
 I can (\*barely) intelligibly speak French.

A third class of ly adverbials may be called the "factive adverbials." Like the scarcely class, they cannot appear after a V and be immediately dominated by VP, and either they lack PP paraphrases or the PP paraphrases

are not the same ones (i.e., "in an AP manner," "in AP fashion," etc.) that manner adverbials have. They differ from the scarcely class, however, in that they can precede the subject NP, provided a breath pause (comma) follows, and in that they seem increasingly unacceptable after a second, third, and fourth auxiliary, and very often after a not or n't. In (36), factive adverbials can appear in all and only the blanks indicated. (Factive adverbials are also the only adverbials which can undergo the previously discussed adverbial dislocation rule.)

- (36) \_\_\_\_\_, John \_\_\_\_\_ sneaked away in time, \_\_\_\_\_. (evidently)  
 \_\_\_\_\_, John \_\_\_\_\_ could \_\_\_\_\_ have ?? been replaced, \_\_\_\_\_.  
 (possibly)  
 \_\_\_\_\_, we \_\_\_\_\_ haven't \_\_\_\_\_ been ?? trying too hard, \_\_\_\_\_.  
 (actually)  
 \_\_\_\_\_, there \_\_\_\_\_ was \_\_\_\_\_ no reason for the disturbance, \_\_\_\_\_.  
 (truly)  
 \_\_\_\_\_, John \_\_\_\_\_ didn't answer the question, \_\_\_\_\_. (wisely)  
 \_\_\_\_\_, John \_\_\_\_\_ won't co-operate, \_\_\_\_\_. (supposedly)  
 \_\_\_\_\_, the birds \_\_\_\_\_ have \_\_\_\_\_ been ?? surviving the  
 pollution, \_\_\_\_\_. (strangely)  
 \_\_\_\_\_, they \_\_\_\_\_ may \_\_\_\_\_ have ?? been taking the right  
 pills, \_\_\_\_\_. (fortunately)

Factive adverbials also differ from both scarcely adverbials and manner adverbials in that a sentence S with a factive adverbial AP can usually (not always) be paraphrased by "it is AP that S." Sentences with the other two kinds of adverbial AP's never have such paraphrases. (The classes of items which may be factive and manner adverbials overlap, but in most cases there is a clear difference in meaning between the two uses; compare (24) on this point.)

The pre-subject position of factive adverbial AP's is possibly due to a root transformation; if so, it would not be a possible deep structure source for these adverbials. There are many types of embedded S's in which such adverbial positions are excluded:

- (37) John bought more paper than I usually do.  
 \*John bought more paper than usually I do.
- The men you supposedly saw were my employees.  
 \*The men supposedly you saw were my employees.
- I wonder whether John has truly lost his talent?  
 \*I wonder whether truly John has lost his talent?
- He came to the realization that John conscientiously would work under his father.  
 \*He came to the realization that conscientiously John would work under his father.
- I am aware that Mary unfortunately has no other home.  
 ?I am aware that unfortunately Mary has no other home.
- He answered the same questions as you wisely had skipped.  
 \* He answered the same questions as wisely you had skipped.
- It angered my employer that I might possibly quit.  
 ? It angered my employer that possibly I might quit.

The judgments of grammaticality in sentences like (37) are not always clear-cut, but there does seem to be a consistent difference. There are some embedded sentences in which pre-subject factive adverbials are acceptable, but these S's seem to be just those in which the restrictions against other root (i.e., non-structure-preserving) transformations are sometimes relaxed. Thus, pre-subject factive adverbials are sometimes acceptable in the S complements of subordinating conjunctions like because, although, so that, etc., and of verbs like believe, say, etc.

Either there is a root transformation of AP preposing, and the acceptable embedded S's with pre-subject factive adverbials are to be explained by appeal to devices of semi-grammaticality, or else the pre-subject AP position is represented in the phrase structure rules, and the starred sentences of (37) must be explained by some other device. But even without taking a stand on this issue, it is possible to argue that the existence of a third class of adverbial AP's in English (beside the

manner and scarcely adverbials) can only strengthen the structure - preserving hypothesis. Alternative arguments can be presented as follows:

(i) Suppose some of the factive adverbial AP's which appear in surface structure positions generated by (30) and (31) are moved to these positions from some other source position. (This source might be the pre-subject position if this is a deep structure position, or it might be from a paraphrase of the type "it is AP that S.") Since these sources are not appropriate for either manner or scarcely class adverbials which appear in these same surface positions, we need some principle which explains why the surface positions of the different classes of adverbials are the same. (For instance, why are the factive adverbials not placed between the verb and its direct object NP?) This principle is the structure-preserving hypothesis.

(ii) Suppose the factive adverbial AP's which appear in surface structure positions generated by (30) and (31) are in these positions in deep structure. (That is, suppose they have the same deep structure sources as scarcely adverbials when they appear between subject NP and main verb.) In this case it would be likely that pre-subject factive adverbials would result from a root transformation. But more important, even though this would not give a new argument for the structure-preserving hypothesis, it would strengthen the argument given earlier based on the partially similar and partially dissimilar distribution of the manner adverbial class and the scarcely adverbial class, since the somewhat small class of scarcely adverbials would be expanded to include the large factive class. A partial similarity between the surface distribution of two such large adverb classes (manner and factive) which have different deep structures cannot be dismissed as accidental.

Thus, whatever the correct analysis of factive adverbials, the structure-preserving hypothesis should not be weakened by it.

A final word in this section concerns adverbial AP's that can occur in all the adverbial AP positions (pre-subject, between subject NP and main V, and after V) with the same meaning. Frequency adverbials (frequently, usually, occasionally, rarely) and certain manner adverbials (gradually, accidentally, quietly, immediately, etc.) appear to have this property. This could be accounted for by moving them transformationally into any AP position required for the correct analysis of the other adverbial classes, or by analyzing them as both factive and manner adverbials which have the combined distribution of both classes but are synonymous in either usage. If all adverbials had this freedom of occurrence it would be evidence against the structure-preserving hypothesis. But once it is evident that at least three other classes have partially the same and partially different distributions, the arguments for separate deep structure positions and structure-preserving rules for adverbial AP's cannot be weakened by the existence of a class with a wider range of occurrence in these positions (i.e., the frequency adverbials and similar types).

This concludes the discussion of AP movement rules. Although the evidence that AP movements are structure-preserving is not as strong as that available concerning NP movements, this lack seems attributable to the relatively small number of generally agreed on transformations which move AP's. A close examination of a rule like manner movement reveals that these rules do not place AP's randomly in trees, but rather in positions which are characteristically shared by other AP's with different deep structure sources.



## IV.2 Structure-Preserving Rules Which Move S Nodes

IV.2.1 Cleft Sentences The reader may wish to refer to the discussion of cleft sentences in Chapter III. I repeat here some of the examples with the focus constituent underlined and the extraposed S, which is characteristic of this construction, parenthesized.

- (38) It was buying a new hat (that I enjoyed).  
 It was a tax break (I counted on).  
 It was the custard pie (which I disliked).
- (39) It was to John (that I spoke).
- (40) It was because it was raining (that I left).

It should be recalled that only NP's and PP's can appear in focus position. Excluded are full sentences, infinitives, adjective phrases, and other verb phrases.

The cleft construction has been a source of confusion to grammarians, since the extraposed S has many but not all the characteristics of a relative clause. For example, the relative pronoun that as well as wh words may appear, while words like why and how, excluded in ordinary relative clauses, can not. Thus, why cannot replace that in (40). There are other factors favoring deriving the extraposed S from a relative clause source, which are set down in a transformational framework in a paper by Akmajian (1970). According to his analysis, the examples of (38) - (40) are derived (roughly) from the structures of (41) - (43), respectively. (Since the focus constituent can be a proper noun, the extraposed S must be a relative clause in the subject NP in deep structure.)

TENSE is omitted in (41) - (43) for simplicity of exposition.

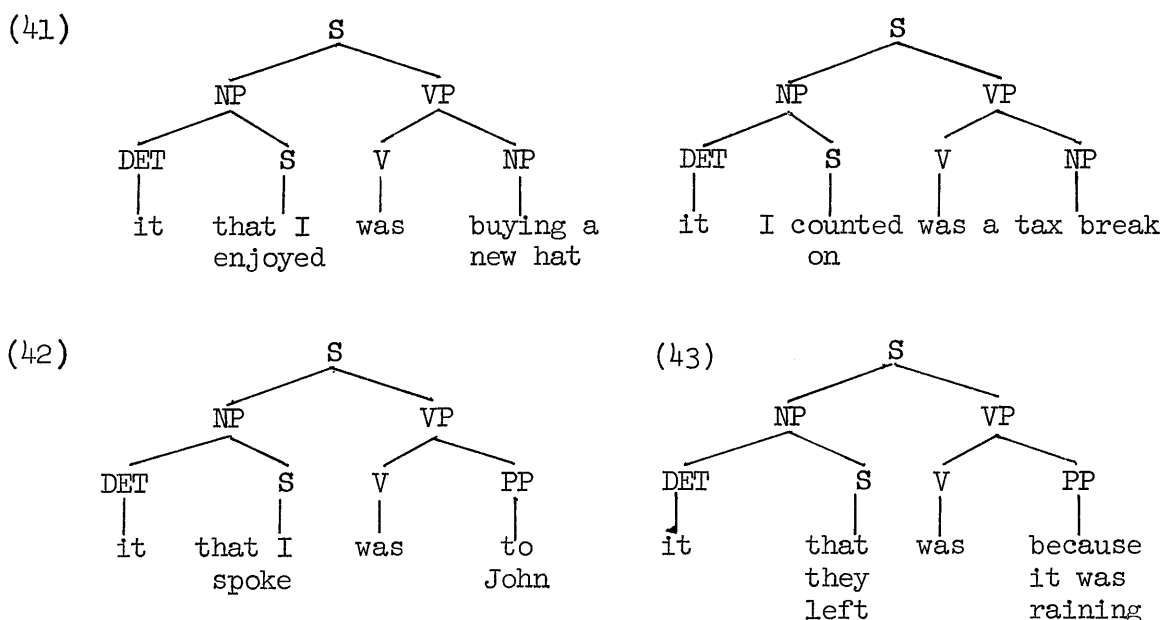

Akmajian assumes that the S's in the deep structure subjects in (41)-(43) are generated as "headless" or "independent" relative clauses, of the type discussed in Kuroda (1968). The trees of (41) - (43) incorporate the suggestion in Postal (1966) that it and other personal pronouns are actually manifestations of the definite article rather than N's.

In fact, it may be a characteristic of cleft sentences that everything except the embedded relative S is (or may be, since various modals may appear in the highest S) empty in deep structure. The definite determiner (it) is inserted into certain empty subject NP's, as discussed at the end of Chapter III; the be in the highest S may be due to an insertion rule (see section II.8); and the constituent in focus position in a cleft sentence may be empty in deep structure (this matter is taken up later in this section). However, I will not pursue this possible characterization of the deep structure of a cleft sentence in detail.

It should be noted that the gender of the DET in the subject NP of

a cleft sentence does not agree with the gender of the predicate nominative: "It (\*he) was John with whom I was speaking." In this, cleft sentences resemble answers to the question "Who's there?" These answers are of the form "It's me" and "It's John" rather than "\*He's me" or "\*He's John."

The principal difficulty with Akmajian's analysis, which has been noted by several grammarians, is the unlikely deep structure such as (42), in which the preposition that appears in the focus PP is (and must be) missing in the relative clause: "It was to John that I spoke (\*to)." Let us accept this defect for the moment, returning to a solution later. This problem is bound up with the question of whether the focus constituent in a cleft construction is in focus position in deep structure or is moved to focus position by another transformation, and for the moment I take no stand on this issue.

In Akmajian's analysis, the cleft construction is due to a transformation which moves the relative clause S to a position at the end of the VP in the highest S, "the cleft extraposition." Such a transformation is structure-preserving, because an S is generable by the phrase structure rules at the end of a VP. If the cleft transformation moved an S to a position where S can't be generated by an independently motivated phrase structure rule, such as before the predicate nominative NP (yielding, say, "\*It may be that owns this car John" rather than "It may be John that owns this car"), then it would not be a structure-preserving rule.

Thus, viewed as a structure-preserving rule, cleft extraposition moves an S constituent according to the arrow in (44). (It should be recalled that empty nodes need not fulfill sub-categorization conditions.)

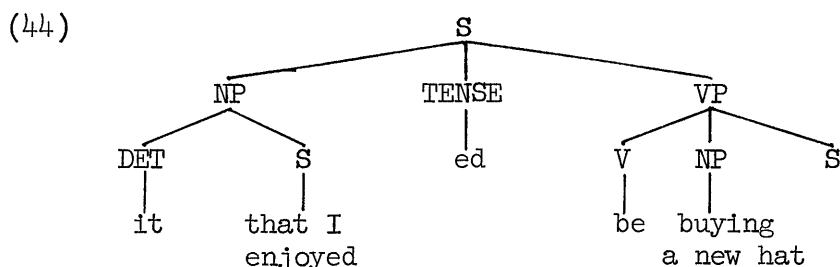

We are now in a position to explain why sentences, infinitives, and other verb phrases cannot appear in focus position in cleft sentences. In section III.1 we saw that, although in some cases intuitions of grammaticality are somewhat unclear, such constituents are generally unacceptable in such constructions. Typical examples are as in (45):

- (45)
- \*It is that we are careless that we should admit.
  - \*It was that they all leave early that the teacher required.
  - \*It was that Mary came home early that John was happy (about).
  - \*It would be for her to be late that would upset me now.
  - \*It is blow up some buildings that you should do.
  - \*It is playing for time that they are doing.
  - \*It was to buy a new house that I wanted.

In order to obtain the sentences of (45) with a structure-preserving cleft transformation, at least one of the following phrase structures would have to be generable by the phrase structure rules:

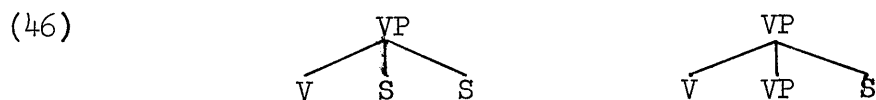

But the impossibility of more than one clausal complement at the end of the VP in surface structure was shown to be the reason why subject replacement is obligatory with a verb like prove when it has both (non-NP) subject and object clauses. (See section III.2.) Thus, the VP expansion rule does not provide the structures of (46); this means that the cleft transformation, which is ordinarily obligatory, cannot move VP's and S's

so as to generate the sentences of (45).

Consider now the fact that predicate nominatives and predicate adjectives do not appear in focus position in the cleft construction.

- (47)
- \*It is quite unhappy that Bill is.
  - \*It was impudent that Mary seemed.
  - \*It was very sick that the children became.
  - \*It is the football coach that John is.
  - \*It was an interesting lecturer that John remained.
  - \*It was tired that John grew.

The ungrammaticality of (47) is not due to the structure-preserving constraint on transformations, but is rather simply further evidence in favor of Akmajian's derivation of extraposed clauses in cleft sentences from deep structure relative clauses. For it is well-known that predicate nominative NP's cannot generally be relativized:

- (48)
- \*The football coach that John was lost the game.
  - \*I saw a German teacher that Harry was.
  - \*Mary was listening to the interesting lecturer that John remained.
  - \*The incompetent fool that the doctor seemed lost the patient.

We can therefore attribute the ungrammaticality of (47) to the fairly general prohibition on relative clauses of the form: "relative pronoun - NP - TENSE - linking verb."

Let us now return to the problem of finding a deep structure source for (39). Akmajian points out in his paper that a structure such as (42) is a dubious deep structure for (39). (Cleft extraposition applied to (42) yields (39).) The reason for this, of course, is that a relative clause of the type "that I spoke" can not be generated in deep structure in any natural way.

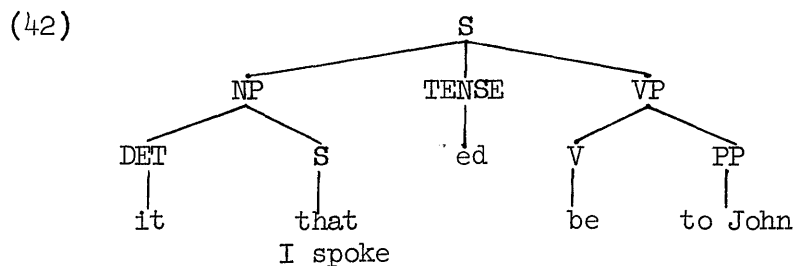

This problem is not directly related to the structure-preserving framework. However, in as much as Akmajian's analysis of cleft sentences provides additional evidence for the structure-preserving hypothesis, it would be helpful if we could eliminate a weakness in this analysis.

The impossibility of generating relative clauses of the type "that I spoke", as in (42), in deep structure by normal rules for relative clauses indicates that (42) itself may be transformationally derived from another source. An obvious candidate for this source is one in which the focus constituent is empty in deep structure. In this view, (42) would be derived from (49) by a movement rule ("focus placement") which has the effect indicated in (49). (Focus placement would precede cleft extraposition.)

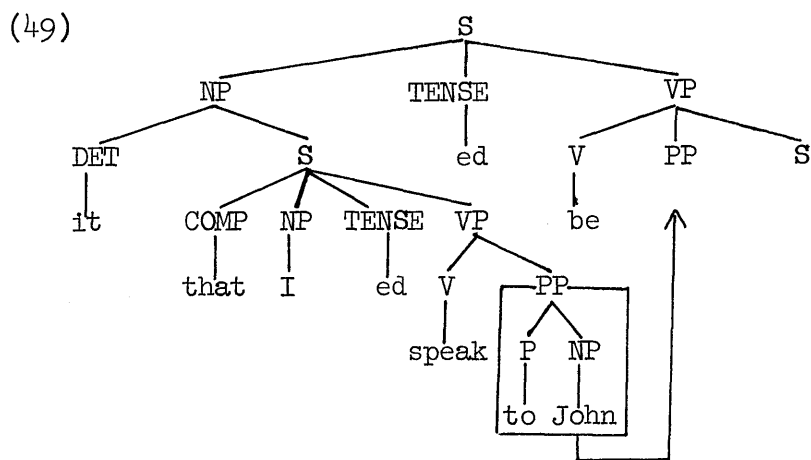

I return to the question of whether this tentative rule (focus placement) is structure-preserving at the end of this section.

The most important general observation about focus placement is that it would play a role analogous to the relativization rule in removing a fully specified NP from a relative clause structure. To see how this is so, we must digress to discuss the derivation of ordinary relative clauses.

Many grammarians have held that that is not a relative pronoun when it introduces relative clauses, but rather the same particle that introduces other (non-relative) dependent clauses. In this view, an NP or a PP replaces COMP (the morpheme that in most clauses) by means of the wh fronting rule. Such an analysis accords the same status to all S-introductory that's, explains why prepositions never precede that even though they precede other relative pronouns, and limits relative pronouns to being a subset of the wh question words. I will accept this position for the present, amplifying on it (but not crucially changing it) in section IV.5.

Furthermore, I will assume that relativization is accomplished in steps, the first step being pronominalization. This means that a deep structure NP which is to be relativized is first either replaced by a personal pronoun or else totally deleted, and is secondly (if it has been pronominalized) moved to the front of its clause and changed to a relative pronoun by wh movement. Thus, a typical relative clause can be derived through the steps outlined in (50).

(50) Deep Structure:  
The friend (that I spoke to a friend) drove away.

Removal of NP by relativization; optional pronoun is left behind:  
A. The friend (that I spoke to him) drove away.  
B. The friend (that I spoke to) drove away.

(50) (cont.)

Wh fronting in A of either NP or PP dominating pronoun  
(obligatory):

- A. The friend (who I spoke to) drove away.
- A. The friend (to whom I spoke) drove away.

Optional that deletion in B:

- B. The friend ((that) I spoke to) drove away.

A similar derivation of cleft sentences is given in (51); notice the analogous roles of relativization and focus placement.

(51)

Deep Structure:

It (that I spoke to a friend) was \_\_\_\_\_.

Removal of NP or PP by focus placement; optional pronoun is left behind if NP is removed:

- A. It (that I spoke to him) was a friend.
- B. It (that I spoke to ) was a friend.
- C. It (that I spoke ) was to a friend.

Wh fronting in A of either NP or PP dominating pronoun  
(obligatory):

- A. It (who I spoke to) was a friend.
- A. It (to whom I spoke) was a friend.

Optional that deletion in B or C:

- B. It ((that) I spoke to) was a friend.
- C. It ((that) I spoke) was to a friend.

Cleft Extrapolation (obligatory):

- A. It was a friend who I spoke to.
- A. It was a friend to whom I spoke.
- B. It was a friend (that) I spoke to.
- C. It was to a friend (that) I spoke.

This analysis correctly predicts the ungrammaticality of "\*It was to a friend who I spoke."

The addition of the focus placement rule to Akmajian's analysis provides a plausible deep structure source for (42). Thus, it appears that cleft extraposition as originally formulated by Akmajian is essentially correct, so that the argument for the structure-preserving hypothesis, presented above in connection with the examples of (45), can stand.



Any thorough investigation of the focus placement rule would have to consider the pseudo-cleft construction in detail. The pseudo-cleft construction resembles the cleft construction in that it has a headless or independent relative clause as a deep structure subject and a be plus attribute predicate; typical examples are given in (52), with the focus constituent underlined.

- (52)      What I enjoyed was buying a new hat.  
           What I counted on was a tax break.  
           What I did to Bill was twist his wrist.  
           What they are doing is painting the house.  
           What the teacher requires is that they all leave early.  
           What would upset me now would be for her to be late.  
           What John is is stupid.  
           What these requirements are are harassment techniques.  
           \*What John spoke was to a friend.

Whatever the correct analysis of the pseudo-cleft construction, and whatever the relation between the pseudo-cleft and cleft constructions, it is doubtful that they would lead to any crucial new evidence for or against the structure-preserving hypothesis. In the first place, if no movement rule such as focus placement is involved in forming the pseudo-cleft construction\* (i.e., if focus placement is limited to the cleft construction or if in fact some other solution to the problem of (42) is ultimately correct), then the structure-preserving hypothesis, principally concerned with movement rules, is not affected.

In the second place, if the correct analysis of the pseudo-cleft construction does involve a movement rule like focus placement, there is

---

\* Bach and Peters (1968) suggest an analysis involving only deletion rules. Another possibility, suggested by Akmajian (personal communication) is that no transformations are involved at all; rather, some principle yet to be made precise would allow predicate attributes to identify not only the subject NP but also, under certain conditions, larger deep structure constituents such as do something to someone.

no reason to suspect that the rule could not be formulated in a structure-preserving manner without changing the rest of the grammar (in particular, without changing the phrase structure rule for expanding VP). For focus placement, if used in deriving pseudo-cleft sentences, would move constituents out of the relative clause dominated by the subject NP into positions immediately dominated by the highest VP, which would dominate only be and empty nodes in deep structure. Since the VP expansion rule provides for every type of major constituent under it (NP's, PP's, S's, VP's, and predicate NP's and AP's), focus placement would be structure-preserving.

Since an exact analysis of the pseudo-cleft construction and of the focus placement rule would seem not to affect the structure-preserving hypothesis, I have omitted a lengthy discussion of them. The important point of this section concerns not focus placement, which I introduced only as a possible solution for a problem in Akmajian's cleft analysis, but rather Akmajian's cleft extraposition rule. As explained above, the fact that this latter rule does not move a clause (VP or S) around a clause already in focus position is independent evidence for the structure-preserving framework, which allows but one (non-NP) clause complement per VP.

IV.2.2 Extraposition from Noun Phrase Besides the cleft transformation, another rule which moves S's from subject NP's to the end of the following VP is "extraposition from NP." It derives the underlined relative clauses in (53) from a position of being immediately dominated by the subject NP.

- (53) A student was speaking who knew very little about politics.  
 (A student who knew very little about politics was speaking.)

(53) (cont.)

A person has arrived who we all like very much.  
 (A person who we all like very much has arrived.)

The conditions for the application of this rule are discussed in some detail in Akmajian (1970). Similar rules or an extension of the same rule probably also move relative clauses to the end of an NP and from inside an object NP to the end of the VP, as suggested in Ross (1967).

(54) The donation of money to the party which had been stolen  
 caused trouble.  
 (The donation of money which had been stolen to the party  
 caused trouble.)

They brought a boy into the room who looked hungry.  
 (They brought a boy who looked hungry into the room.)

Mary typed out a letter to her brother which didn't make sense.  
 (Mary typed out a letter which didn't make sense to her brother.)

Whatever the details of the conditions on this rule, it is clearly structure-preserving, since it moves S's to the end of the VP or NP, where S complements are generable by the phrase structure rules.

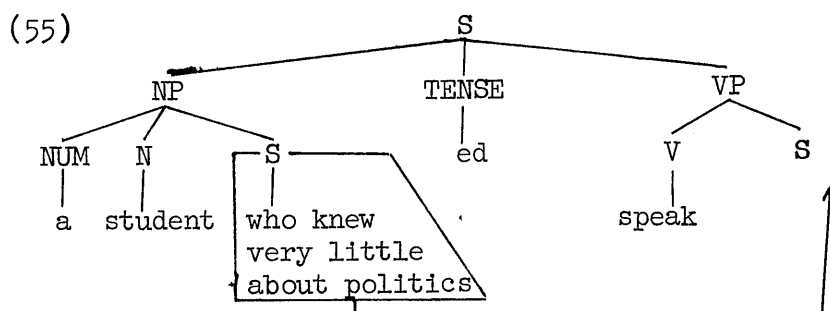

(Compare the "sentential relative" construction in "Mary typed out a letter to her brother, which didn't make sense," where we can assume the wh is not dominated by the VP of the main clause.)

It is important to see how the structure-preserving hypothesis explains rather than simply describes this extraposition rule (or the cleft extraposition). Given the phrase structure rules of English, this

hypothesis claims that extraposition rules with outputs like the examples in (56) are impossible. Without the hypothesis, such rules would have the same status as the existing English extraposition rules, a counter-intuitive result.

- (56) \*A student was speaking who knew very little about politics  
to John.  
\*A man entered who was from Philadelphia the room.  
\*A person has who we all like very much arrived.

IV.2.3 Complement Extraposition In this section, I will describe a rule which produces sentences which may not be fully grammatical. It is nonetheless important, because it distinguishes two sets of examples, one of which has totally ungrammatical members, and the other of which has grammatical or marginally grammatical members, depending on the meanings involved, etc. The transformation which produces these differences, "complement extraposition," may therefore be an extra-grammatical device, but there is no doubt as to its being part of English usage. It is of interest here because it is a structure-preserving rule.

Of course, complement extraposition may be totally grammatical in some dialects, but the more complex constructions in which it plays a part seem only marginally acceptable to most speakers. The main point is that, for any given level of complexity, the sentences which do not involve complement extraposition do not permit, with the same degree of acceptability, certain operations that sentences which do involve it do. Thus, the reader should lower his "acceptability threshold" in this section, paying attention to the differences in acceptability that the paired starred-unstarred examples exhibit.

In (57), the head nouns of the deep structure objects have S

complements.

(57) John made the claim that the rain was causing the accidents.  
The claim that the rain was causing the accidents was made  
by John.

Susan made the assumption that Mary would reject her offer.  
The assumption that Mary would reject her offer was made by  
Susan.

John made a guess that the river was somewhere to the east.  
A guess that the river was somewhere to the east was made  
by John.

Tom made the conjecture that Bill was telephoning Harry.  
The conjecture that Bill was telephoning Harry was made by Tom.

They made the assertion that we couldn't prove Riemann's theorem.  
The assertion that we couldn't prove Riemann's theorem was made.

The same can be said for (58).

(58) John ridiculed the claim that the rain was causing the accidents.  
The claim that the rain was causing the accidents was  
ridiculed by John.

Susan questioned the assumption that Mary would reject her offer.  
The assumption that Mary would reject her offer was questioned  
by Susan.

John relied on a guess that the river was somewhere to the east.  
A guess that the river was somewhere to the east was relied on  
by John.

Tom discussed the conjecture that Bill was telephoning Harry.  
The conjecture that Bill was telephoning Harry was discussed  
by Tom.

They didn't appreciate the assertion that we couldn't prove  
Riemann's theorem.  
The assertion that we couldn't prove Riemann's theorem wasn't  
appreciated.

In (57), the sentence complements of the deep structure objects can be extraposed in the passive construction, but this is not so in (58). In general, the condition for this extraposition seems to be that the main verb be a "pro-verb" (of minimal semantic content), such as make

or have, which does not in this context have its literal meaning before such objects.

- (59) The claim was made by John that the rain was causing the accidents.  
 The assumption was made by Susan that Mary would reject her offer.  
 A guess was made by John that the river was somewhere to the east.  
 The conjecture was made by Tom that Bill was telephoning Harry.  
 The assertion was made that we couldn't prove Riemann's theorem.
- \*The claim was ridiculed by John that the rain was causing the accidents.  
 \*The assumption was questioned by Susan that Mary would reject her offer.  
 \*A guess was relied on by John that the river was somewhere to the east.  
 \*The conjecture was discussed by Tom that Bill was telephoning Harry.  
 \*The assertion wasn't appreciated that we couldn't prove Riemann's theorem.

The optional structure-preserving S movement that precedes the passive transformation, making possible the acceptable passive constructions of (59), is indicated by the arrow in (60).

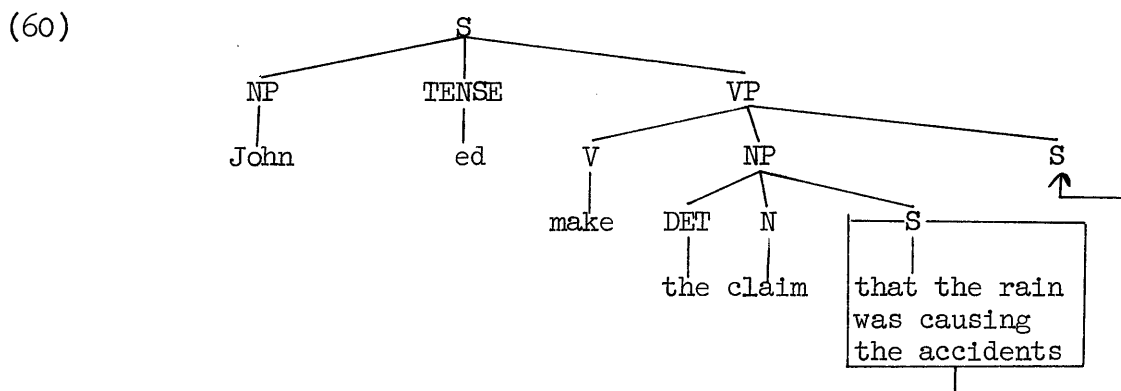

I will call this rule "complement extraposition."

This rule provides an explanation for certain other characteristics of S complements to phrases like make the claim, make a guess, etc.

The introductory that of S complements to nouns ordinarily cannot

be deleted. For example, that cannot be deleted in (58) or in the passive sentences of (57). However, an introductory that may be deleted in many S complements to verbs, as in (61a).

- (61a) John claimed (that) the rain was causing the accidents.  
 Susan assumed (that) Mary would reject her offer.  
 John guessed (that) the river was somewhere to the east.

It is also true that that may be deleted in at least some of the sentences of (57) in what are superficially S complements to nouns; the extent of the deletability of that seems subject to dialectal variation.

- (61b) John made the claim the rain was causing the accidents.  
 Susan made the assumption Mary would reject her offer.  
 John made a guess the river was somewhere to the east.

The important point here is that that can be deleted in S complements to nouns only if that complement is extraposed. That is, that cannot be deleted in complements to nouns which may not be extraposed:

- (61c) \*John ridiculed the claim the rain was causing the accidents.  
 \*Susan questioned the assumption Mary would reject her offer.  
 \*John relied on a guess the river was somewhere to the east.  
 \*Tom discussed the conjecture Bill was telephoning Harry.  
 \*They didn't appreciate the assertion we couldn't prove  
 Riemann's theorem.

Thus, we can preserve the generalization that that deletion doesn't occur inside noun phrases by making it contingent on complement extraposition. (In my dialect, that deletion sometimes may not take place even when complement extraposition takes place. For example, it may not take place in the grammatical passive sentences of (59).)

According to the complex NP constraint given in Ross (1967), the rule of wh fronting may not extract an NP from an S which is dominated by an NP

which has a head noun (and place it outside the dominating NP). In particular, wh fronting may not remove an NP which is part of an S complement to a noun. This constraint predicts the ungrammaticality of the sentences in (62a).

- (62a) \*The rain that John discussed the claim caused the accidents lasted for hours.  
 \*Who did Susan question the assumption would reject her offer?  
 \*They set out for the river which John had relied on a guess was to the east.  
 \*What did John ridicule the claim the rain was causing?  
 \*Where did John rely on a guess the river was?  
 \*The offer Susan is questioning the assumption Mary will reject is quite generous.

Sentences in which wh fronting extracts an NP from an S complement to phrases like make the claim and make a guess are much more acceptable, at least in many cases, than the corresponding sentences of the type given in (62a):

- (62b) The rain that John made the claim caused the accidents lasted for hours.  
 ?Who did Susan make the assumption would reject her offer?  
 They set out for the river which John had made a guess was somewhere to the east.  
 What did John make the claim the rain was causing?  
 ?Where did John make a guess the river was?  
 The offer Susan is making the assumption Mary will reject is quite generous.

We can ascribe the acceptability of these sentences to the fact that the S complements from which wh fronting extracts an NP are extraposed. That is, the complex NP constraint does not prevent wh fronting from applying in (62b) since the S complements in the structures underlying (62b) are not immediately dominated by an NP with a head noun when wh fronting applies. (A dialect in which the examples of (62b) are unacceptable and those of (62a) doubly unacceptable could be described by



ordering wh fronting before complement extraposition. In such a dialect, these two rules would have to apply in the wrong order to produce the somewhat unacceptable sentences of (62b), but there would be no ordering of rules which could yield the totally unacceptable sentences of (62a).)

Another rule which cannot extract NP's from S complements to nouns is the non-factive complement preposing rule of section I.7.3.

- (63) \*The incessant rain, John ridiculed the claim, was causing  
the accidents.  
\*The river, John relied on a guess, was somewhere to the east.  
\*Bill, I accept the idea, could live elsewhere.

Again, if the extracted NP's are from S complements to phrases like make the claim and make a guess, the resulting sentences are more acceptable:

- (64) The incessant rain, John made the claim, was causing the  
accidents.  
The river, John made a guess, was somewhere to the east.  
Bill, I have an idea, could live elsewhere.

I attribute the ungrammaticality of sentences like (63) to the fact that the complex NP constraint does not permit rules to take constituents out of S complements to nouns which are not extraposed, as are those in (64).

It appears therefore that the rule of complement extraposition is well-motivated, and another example of a structure-preserving S movement rule. Of course, the more instances there are of transformations with the same output (S's as the last constituents under a VP in the case at hand), the more important it is that the non-accidental character of this be reflected by appropriate general principles (such as the structure-preserving constraint) which limit the notion "possible transformation."

IV.3 The Node PP and its Distribution\* In this study, the node label PP indicates not only prepositional phrases in the traditional sense of that term (preposition with NP object), but also clauses introduced by subordinating conjunctions and certain other adverb phrases. Some justification for this should be given.

The traditional prepositional phrase, generated by the rule  $PP \rightarrow P - NP$ , can serve as an adjunct to a noun, verb, or adjective; the extremely varied uses of PP in English are well known. Such phrases, however, are better seen not as an isolated phrase type, but as part of a larger paradigm.

Among the traditional "parts of speech," only verbs and prepositions generally take (direct) "objects." But some verbs take no object, others take only sentence or infinitive (S) complements, and others take various combinations of  $\emptyset$ , NP, and S. If we extend these properties of verbs to prepositions, the traditional "prepositions" become transitive prepositions, the heads of prepositional phrases; the traditional subordinating conjunctions become prepositions with sentence complements, the heads of prepositional clauses; and certain traditional simple adverbs (of those not derived from adjectives) become intransitive prepositions. In this way, the following structural parallels can be set up:

---

\* Many of the ideas of this section are due to personal communications with Edward S. Klima, especially those which postulate similarities between verbs and prepositions. Michael Geis, (1970), *Following the Lead of the Verb*, derives all subordinate clauses from (traditional) PP's. This analysis is compatible with any remarks made later in this section on PP movement rules in connection with the structure-preserving hypothesis. It is these remarks, of course, and not the introductory analysis of the node PP, which is important to our hypothesis.

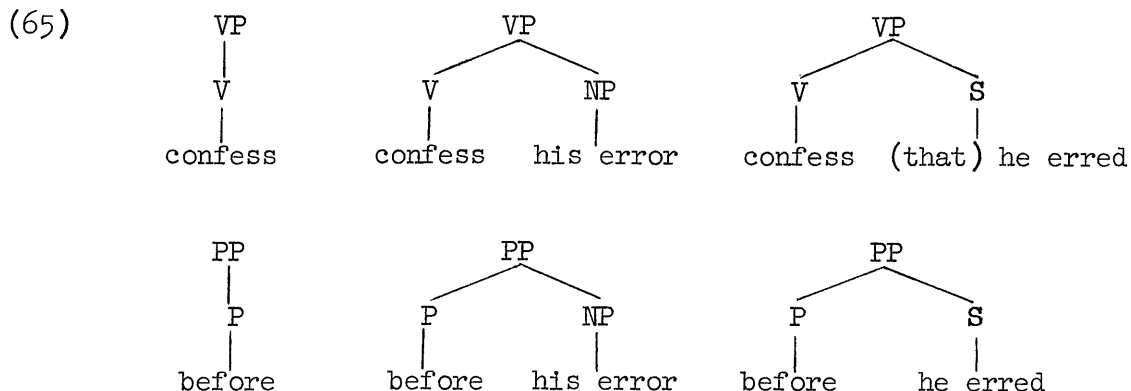

Prepositions which take different combinations of complement types are given in (66):

- (66)
- John arrived before the last speech.  
 John arrived before the last speech ended.  
 John arrived before(hand).
- He did it because he was proud.  
 He did it because of his pride.  
 \*He did it because.
- They were singing in(side) the house.  
 They were singing inside.  
 \*They were singing in(side) the people were dancing.
- I haven't seen him since the party began.  
 I haven't seen him since the party.  
 I haven't seen him since.

One might also want to relate the following:

- (67)
- They are unwise in trying to escape.  
 They are unwise in that they are trying to escape.
- What would he say now?  
 What would he say now that the news is out?

In section IV.2.1 I discussed the cleft construction in detail, showing why only NP's and PP's could occupy the "focus" position. This accords well with the extended notion of PP introduced here, since the adverbs and subordinate clauses that I am analyzing as PP's can be found

in this position also:

- (68) It was because John left that Mary cried.  
 It was after the president had finished that the disorder  
       began.  
 It was afterwards that the news broke.  
 It's upstairs that we have no heat.

Certain NP's like yesterday, every morning, last week, etc. are used as adverbs of time. Their ability to prepose inside other NP's (cf. the possessive transformation discussed in section II.6) indicates that they are NP's:

- (69) Yesterday's newspaper, every morning's news, last week's  
       weather, etc.

In order to regularize statements of NP distribution, I will assume that these NP's are dominated by PP in deep structure (whose head is probably on). The P of this PP is then deleted in surface structure. (Cf. "He is (at) home"; "He did it (in) the wrong way.") This deletion of P was discussed in detail in section II.3.

Confirmatory evidence in favor of combining prepositions, subordinating conjunctions, and certain adverbs into the single syntactic category P is the behavior of the particle right. The members of the category P which express spatial or temporal location and direction (but not frequency) can all be preceded by right.

- (70) He kept on drinking right until midnight.  
 She put it right into her pocket.  
 The boy came right from the store.  
 They kissed right after the ceremony.
- He came in right before the party started.  
 He kissed her right while her boy friend was looking.  
 I know right where he is.

(70) (cont.)

Come in here right now!  
I know I put it right here.  
I should be doing it right this minute.

(Notice, for example, that while, which takes only S complements, can be preceded by right.) Before adjectives and before manner or frequency adverbials, right is not allowed in standard English.

(71) \*They came over right often.  
\*John drove right carefully.  
\*She is right pretty.  
\*Fights happen right seldom around here.

There are, as expected in this analysis, prepositional clauses containing infinitives rather than full sentences, such as those introduced by so as and in order. There is even one preposition (lest) which takes a present subjunctive S complement, parallel to verbs like require. Thus, prepositions take the same range of complements as do verbs; however, there is the difference that prepositions take apparently at most one complement.

The general rule for expanding PP, then, is (72). RT is the pre-terminal symbol for right, and co-occurs only with P's of a certain semantic class, as shown by (70) and (71).

$$(72) \quad PP \rightarrow (RT) - P - \left( \begin{array}{c} NP \\ S \end{array} \right)$$

(72) is a rule specifying the interior structure of PP's; let us now consider rules which generate PP's under other constituents. Rules of the following kind have appeared earlier in this paper:

$$(73) \quad \begin{array}{l} NP \rightarrow \dots N \dots - (PP)^* - (S) \\ VP \rightarrow \dots V \dots - (PP)^* - (S) \end{array}$$

(The S in (73) yields a full sentence or an infinitive, at least in surface structure.) Probably the rules in (73) are part of a more general rule schema, such as that given in (74), but this is not important for our purposes here.

$$(74) \quad \left\{ \begin{array}{l} \text{NP} \rightarrow \dots \\ \text{VP} \rightarrow \dots \\ \text{AP} \rightarrow \dots \end{array} \right\} - (\text{PP})^* - (\text{S})$$

(73) or (74) are not sufficient, however, to account for all prepositional clauses and phrases. A number of prepositions (because (of), in case (of), on account of, in order, so that, in that, now that, if, unless, despite, although, in spite of, etc.) are not generable inside NP, AP, or, if we judge by the position of the S complement, inside VP's which immediately dominate V's. (Appropriate constituents are underlined in (75).)

- (75) \*Stalin's military blunders because of his ideology are understandable. (NP)  
 Cf. It is understandable that Stalin blundered militarily because of his ideology.
- \*I had heard of John's despair because he had lost his money. (NP)  
 Cf. I had heard that John despaired because he had lost his money.
- \*He forbid his son because of the unrest to attend that college.  
 Cf. He forbid his son to attend that college because of the unrest. (VP)
- \*How rich if you are a farmer can you become? (AP)  
 Cf. How rich can you become if you are a farmer?
- \*Tom's co-operation despite his previous mistreatment was surprising. (NP)  
 Cf. That Tom co-operated despite his previous mistreatment was surprising.
- \*It upset John because his parents were there that Mary was late.  
 Cf. It upset John that Mary was late because his parents were there. (VP)

(75) (cont.)

\*A crisis on account of widespread unemployment is sure to come.  
 Cf. On account of widespread unemployment, a crisis (NP)  
 is sure to come.

PP's in the class being discussed here characteristically appear only at the end of VP's; more precisely, they may and often must follow S or VP complements to the main verb. All but two of the grammatical sentences of (75) exhibit such constructions. I will assume, therefore, that PP's introduced by words like because are not generated by (73), but should originate at the end of sentences or infinitives (i.e., at the end of S's or VP's) or perhaps at the end of both, by means of a rule like (76) or (77).

(76) S → S - PP

(77) VP → VP - PP

For the moment, whether (76) or (77) is part of the grammar is not important; for purposes of exposition, I arbitrarily choose (77).

Consider now the paraphrases in (78).

(78) John knew before he married her that she was intelligent.  
 John knew that she was intelligent before he married her.

It isn't necessary on this campus to be very smart.  
 It isn't necessary to be very smart on this campus.

It seems sometimes that we'll never obtain peace.  
 It seems that we'll never obtain peace sometimes.

Mary demonstrated in very convincing fashion last Saturday  
 that John shouldn't be licensed.  
 Mary demonstrated last Saturday that John shouldn't be licensed  
 in very convincing fashion.

It frightened me when I was a child to be examined by a doctor.  
 It frightened me to be examined by a doctor when I was a child.

(78) (cont.)

It meant nothing after Einstein had devised his theory to  
speak of simultaneity.

It meant nothing to speak of simultaneity after Einstein  
had devised his theory.

Given the rule (77), the following surface structures can be assigned  
to a typical pair of sentences in (78):

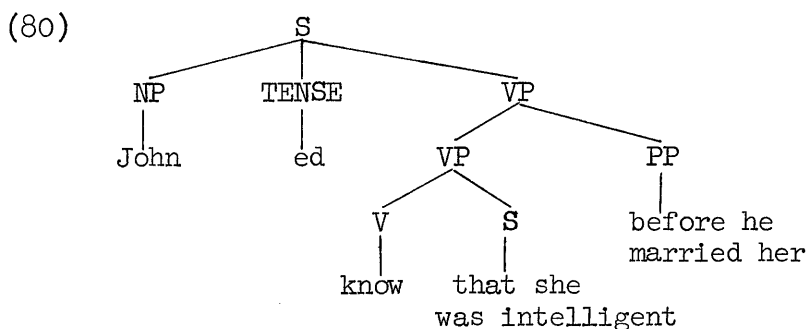
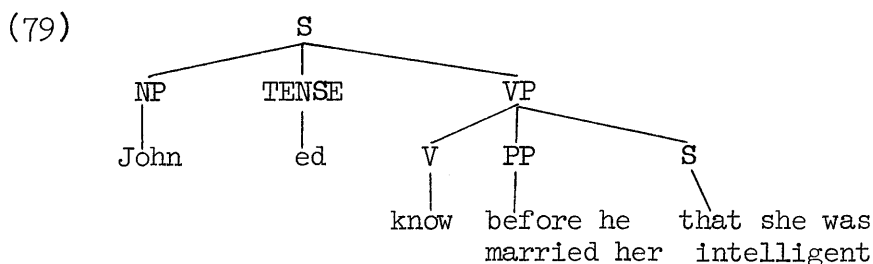

I will not take a position on which of (79) and (80) is basic. Since the phrase structure rules generate PP's in positions of the PP's in both (79) and (80), independently of the constructions being considered here (locative PP's of space and time, manner adverbial PP's, etc.), any movement transformation which relates (79) and (80) can be formulated as structure-preserving. For example, if (79) is to be derived from (80), the rule accomplishing this derivation has a structure-preserving effect, as indicated in (81):



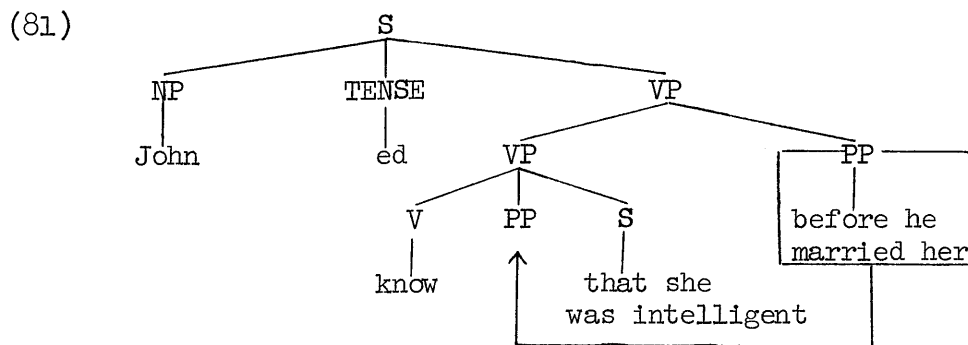

The structures generated by (77) allow us to extend the results in Lakoff and Ross (1966) concerning the do so construction. They propose that a sentence like (82) be derived from a structure like (83) by means of a rule like (84).

(82) John told us the game was cancelled before we left, and Mary did so at the airport.

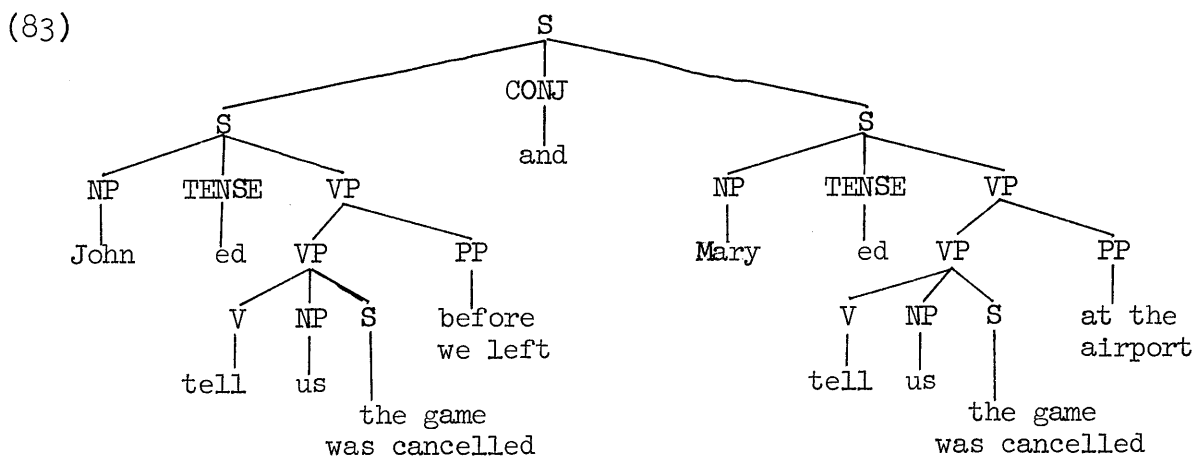

(84) X - VP - Y - VP - Z  $\Rightarrow$  1 - 2 - 3 - do so - 5,

where 2 = 4 and  
2 begins with a non-stative  
verb.

(84) similarly derives (85) from a structure like (83) in which at the airport is replaced by before we left (and too is added as a constituent immediately dominated by the S whose subject is Mary).

- (85) John told us the game was cancelled before we left, and  
Mary did so before we left, too.

But (84) also (correctly) derives (86) from such a structure:

- (86) John told us the game was cancelled before we left and  
Mary did so too.

The fact that either of the VP's in the righthand S of a structure like (83) can be deleted by (84), given identity with a VP in a lefthand S, is justification for the rule (77) which specifies a VP-over-VP configuration.

There can be little doubt that the do inserted by (84) is dominated by V, since the TENSE affixes attach to this verb as to any other. This has led Ross (forthcoming) to investigate the possibility that VP's whose heads are non-stative are complements to a deep structure do in underlying structure. That is, he assumes that the VP in (83) which is deletable by (84) should be replaced by the following structure, in which the lower VP is essentially transformationally replaced by so.

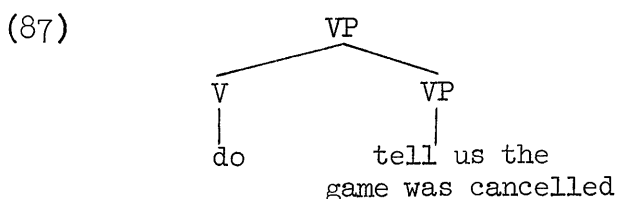

(Actually, Ross assumes that the lower VP in (87) is immediately dominated by NP; I discussed this assumption in detail in Chapter III. For the purpose of this discussion, this discrepancy between Ross's analysis of (83) and mine is not important.)

This hypothesis of Ross's, if correct, leads to the question of whether the so in sentences like (82), (85), and (86) continues to occupy

the S position at the end of the VP whose head is do. If the so in sentences like (88) is inserted by the same rule which deletes clause complements after do (a modified version of (84)), evidence is available on this question.

(88) John said the play would soon start and Bill said so too.

S complements generally follow the to phrase after say:

(89) \*John said that the play would soon start to Mary.

Yet so must precede rather than follow a to phrase after say:

(90) John said to Mary that the play would soon start, and

Bill said { so to Joan }.  
                  { \*to Joan so }

Thus, it seems that so, as inserted by (84), is a particle which immediately follows do and not an S or a VP sister to do. This means that the S position at the end of a VP like do so or think so is empty in derived structure. In turn, this explains why a structure-preserving rule like extraposition from NP may sometimes insert an S at the end of such a VP.

(91) A woman came in who had two books and a man did so who had one.  
      Nobody thought so who had any sense.  
      Cf. \*Nobody thought that the movie was good who had any sense.

If so is not in the S position in derived structure, an empty S is available at the end of the VP for a rule like extraposition from NP:

(92)

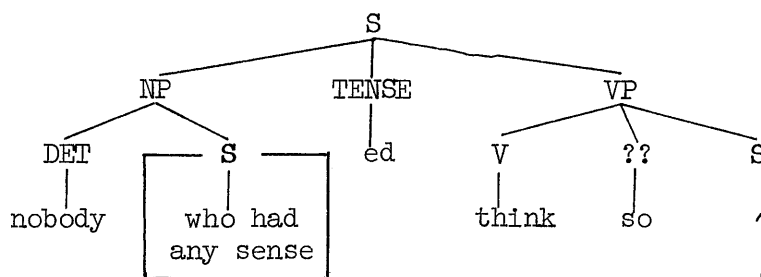

We have seen in this section that if the pairs of sentences in (78) are to be related transformationally, the PP movement rules which accomplish this are structure-preserving. (They can be formulated in a structure-preserving way because PP's which are sisters to V's and to VP's are generable by independently motivated phrase-structure rules.) In section IV.2, we saw that there is possibly a focus placement rule for cleft sentences which is structure-preserving and applies to PP's. In the following section, we will see that the evidence for a structure-preserving formulation of wh fronting involves the transformational movement of PP's in a crucial way (i.e., certain special conditions on wh movement will be inexplicable unless we assume that the structure-preserving constraint applies to PP movement rules). Thus, there is a fair amount of evidence that PP movement rules are, like NP, S, and AP movements, structure-preserving.

IV.4 Wh Fronting as a Structure-Preserving Rule In this section I discuss the problem of wh fronting in the structure-preserving framework. This rule moves an NP, PP, or AP to the front of the clause if they are introduced by one of the wh words such as who, what, which, when, where, why, how, whose, whether, and a few others. (The wh word may be preceded by a preposition.) In certain contexts the rule may not operate, and in others it moves a constituent which dominates the constituent introduced

by the wh word, as in "the father of whom." It is usually held that general conditions on movement rules predict these special cases automatically, so that the statement of wh fronting itself is straightforward; these general conditions were studied extensively in Ross (1967).

Some typical uses of wh fronting are given in (93), along with the usual name given to the construction which the wh word introduces.

(93) Direct questions in full sentence form:

Whose father was the president?  
 In which town does he reside?  
 How did he achieve this?  
 How big does this appear on a screen?

Direct questions in infinitive form; only why permitted:

Why buy more stock at this time?  
 Why knock yourself out for someone else?

Exclamations:

What big paws he has!  
 How brave he is!

Conditional clauses:

Whatever measures they take, they are sure to fail.  
 However long you stay, you will be welcome.

Relative clauses in full sentence form:

I found a man who you can buy tickets from.  
 I found a man from whom you can buy tickets.  
 The taste of what they are serving is delicious.  
 The only place where I feel at home is in a city.

Relative clauses in infinitive form:

I found a man from whom to buy tickets.  
 You have fifteen days in which to finish.  
 Some tools with which to work will soon arrive by mail.

Indirect questions after nouns in full sentence form:

The problem of how often we should meet hasn't been discussed.  
 John's understanding of how this works is faulty.

Indirect questions after verbs in full sentence form:

I wonder whether he will show up.  
 I forgot how efficient she was.  
 They weren't sure (of) why she left.

(93) (cont.)

Indirect questions after nouns in infinitive form:

The question of who to consult in this matter is perplexing.  
They have no knowledge of which routes to take.

Indirect questions after verbs in infinitive form:

They told you how to operate that.  
John asked Mary when to stop.

It is imperative that we investigate wh fronting carefully, for it is certainly not a minor movement rule or a root transformation. (It operates in embedded sentences which do not exhibit subject-auxiliary inversion; furthermore, root transformations which are fronting rules take constituents to the very front of the highest S in the tree, as pointed out in section III.1.) Thus, if our structure-preserving hypothesis is to stand in its present form, wh fronting must be a structure-preserving rule. That is, it should operate according to the diagram of (94) in embedded sentences at least, subject to movement constraints such as those formulated in Ross (1967).

(94)

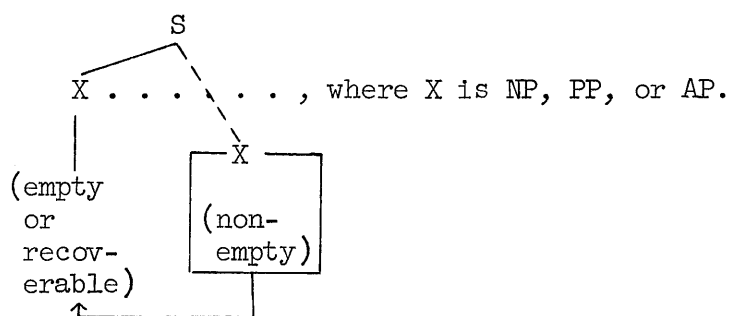

(The dotted line in (94) signifies domination which need not be immediate domination.)

In this section, I will discuss in detail the operation of wh fronting in relative clauses in order to see if there is any basis for a structure-preserving formulation of wh fronting, as in (94). I will conclude with some incomplete remarks on indirect questions; any definite conclusion

that wh fronting is a structure-preserving rule will require a more thorough analysis of this rule than I can make at this time.

In the discussion of cleft sentences (section IV.2.1), some reasons were given for considering that wh fronting in relative clauses substitutes an appropriate NP or PP for the COMP node which ordinarily dominates that in surface structure. Even without appealing to the structure-preserving constraint, this assumption would mean that wh fronting in relative clauses is at least a substitution transformation, as in (95).

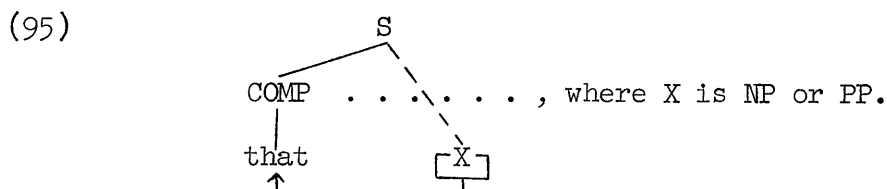

In order to show that wh fronting is structure-preserving, we must show that (95) should be revised to (96), which would mean that the phrase structure rule for expanding S is (97). (I assume that essentially the same formal devices are appropriate for both relative clauses and indirect questions; hence I include AP in (96) and (97).)

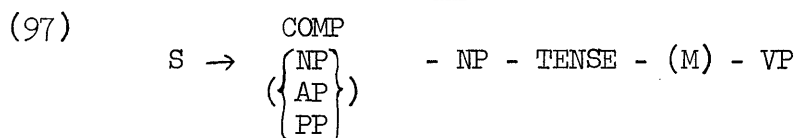
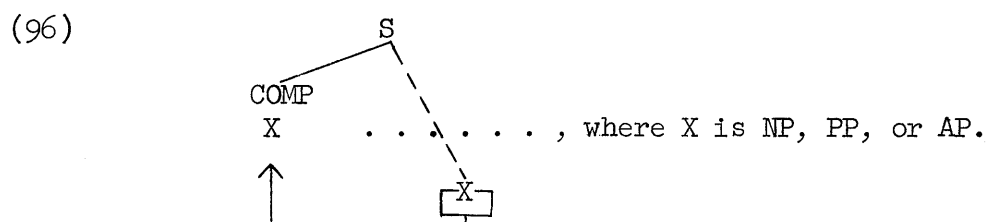

If (97) is correct, wh fronting should be stated as moving any phrase node, the exclusion of VP and S being accounted for by the S expansion

rule. The impossibility of fronted AP's in relative clauses is apparently due to a more general prohibition on how in relative clauses:

- (98) The students { \*how many  
whose parents } I've met are friendly.  
\*The way how he got here was strange.

(97) is undesirable in that the phrase nodes under COMP are always empty in deep structure; i.e., no semantic projection rule or rule of interpretation operating on deep structures refers to them. There is nonetheless evidence that (96) and (97) do reflect the nature of wh fronting. For example, a minor advantage of (97) is that it automatically excludes the possibility of two wh constituents being fronted in the same S.

A proper presentation of the main evidence for (96) and (97) requires that I first digress to examine a seemingly unrelated problem: I must determine the structure and origin of an expressed subject of an infinitive, when these are preceded by for, as in (99).

- (99) It is too cold for her to swim.  
For the radio to be on would add to the tension.  
It wouldn't be polite for them to leave.  
Some clothes for you to mend will be arriving soon.  
I prefer for the room to be air-conditioned.

Two possible structures for such infinitives suggest themselves:

(100) (a)

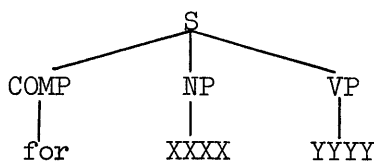

(b)

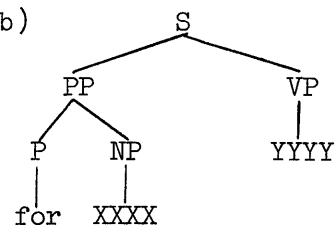



There are two reasons why (100b) is preferable to (100a).

(i) We would like to be able to characterize the subject pronouns of English (I, he, she, we, they) as the pronouns which appear in just those NP's immediately dominated by S, or at least to reduce the exceptions to this statement. For example, Klima (personal communication) has pointed out that a very common dialect of children exhibits subject pronouns in single NP subjects, but object pronouns in conjoined NP subjects, as in "Me and him left" or "Me and him, we left." This can be explained by noting that the subject NP's in conjoined subjects are immediately dominated by another NP rather than by S. Immediate domination by S as a condition for subject pronouns also explains the common dialect of Modern English in which whom, an object pronoun, appears only if a PP is wh fronted, whereas who appears in any fronted NP. ("To whom did you write?" vs. "Who did you write to?")

If (100b) is the structure of an infinitive with a for-NP subject, such subject NP's, which always exhibit object pronouns, are not an exception to the general condition on subject pronouns. But if (100a) is the structure, then an ad hoc exception to this condition stated in terms of a lexical property of for must be made.

(ii) It does not seem to be an accident that almost every morpheme X which is transformationally inserted under an empty node of category C also has a regular lexical meaning in which it is also of category C. (This is true of do, it, the, of and perhaps of have and be, while it is not true of there.) Since for is a P (preposition) in one of its regular lexical meanings, it is to be expected that it is transformationally inserted under the category P, as in (100b).

This correlation between deep structure categories of a morpheme and

the categories under which this morpheme is transformationally inserted might be accounted for along the following lines: Every lexical meaning for a given morpheme X is really an insertion rule for X which is to be applied at the level of deep structure. Thus, transformational insertions of X may be listed in the grammar as part of the lexical entry of X, with a special marking that the insertion in question operates not at the deep structure level, but at some other point of the transformational derivation. In this way, all the insertions of X, both deep structural and transformational, would be listed together in the lexical entry for X. It would be a simple matter to mention the category of X but once in all those cases that X has the same category, and this would reflect the high frequency of transformational insertions of morphemes of deep structure category C under empty nodes of category C.

I conclude, therefore, that (100b) is the structural representation of the infinitives of (99). Given this, we must next determine the source of such a structure.

Infinitives of the kind found in (99) are very closely related in form, distribution, and meaning to the present subjunctive constructions.

In form, the two constructions differ only in that the present subjunctive subject has a COMP-NP structure, whereas the infinitive subject has a  $PP \left[ P-NP \right]$  structure. Otherwise, they both lack modals and the finite TENSE affixes, they both exhibit the same placement of not, etc.

- (101) They say that John isn't (is not) given special treatment.  
 They demand that John not be given special treatment.  
 \*They demand that John be not given special treatment.  
 They arranged for John not to be given special treatment.  
 \*They arranged for John to be not given special treatment.

(101) (cont.)

He says that John must read that book.  
 He demands that John (\*must) read that book.  
 He arranged for John to (\*must) read that book.

The distribution of present subjunctives is more limited than that of infinitives with for-NP subjects, but almost every word which can take a present subjunctive complement can also take an infinitive, or at least the word taking a present subjunctive complement is in a class of words which ordinarily take infinitive complements. Thus, the adjectives of the class including important, necessary, preferable, desirable, urgent, etc. and verbs of the class order, command, require, prefer, etc. take either present subjunctive complements or infinitive complements. The few words which take only present subjunctive complements, such as the verb demand (when the complement has an expressed subject) or the subordinating conjunction lest, are closely related to similar words which take infinitive complements (respectively, the verb require and the subordinating conjunction in order).

More important than the similar distribution of present subjunctives and infinitives with for-NP subjects, however, is the fact that they are identical in meaning when both can appear as the complement of a given word, as in (102).\*

---

\*There are verbs which can take a present subjunctive complement, and an infinitive complement with a slightly different meaning, but in these cases for does not precede the subject NP of the infinitive. The usual explanation is that the NP following the higher verb is really not the subject of the infinitive (hence no for), but rather the object of the higher verb (this can account for the meaning difference), the subject of the complement being deleted in surface structure. Examples of such distinctions are as follows:

He ordered that the boy leave the room.  
 He ordered (\*for) the boy to leave the room.  
 He ordered that the lawn be cut.  
 \*He ordered the lawn to be cut.

- (102) It is important that the room be air-conditioned.  
 It is important for the room to be air-conditioned.  
 ≠ It is important that the room is air-conditioned.
- He prefers that his officers be militarists.  
 He prefers (for) his officers to be militarists.  
 ≠ He prefers it that his officers are militarists.

Let us assume with Kiparsky and Kiparsky (1968) that a rule of modal deletion can derive present subjunctives from full sentences. The similarities between infinitives and present subjunctives and the similarities that full sentences, present subjunctives, and infinitives all have in common, can all be accounted for by subsequently deriving infinitives with for-NP subjects from present subjunctives by a rule of "infinitive formation." (In some cases, this rule is obligatory, while in others, as with the complements of prefer and important, it is optional.)

Thus, I assume that the structure of a present subjunctive is as in (103). This means that infinitive formation must derive a structure very close to that of (100b) from that of (103).

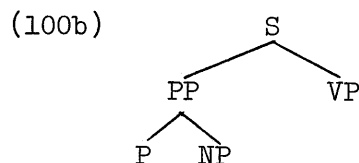

For purposes of exposition, I will use the rule whose existence I am trying to justify, the S expansion rule (97), to set up a tentative formulation of the rule deriving infinitives from present subjunctives. I will subsequently show that this procedure makes some very precise predictions about the grammaticality of certain classes of sentences which are empirically confirmed, thus validating the original use of (97) as a guide for formulating the infinitive formation rule.

Proceeding in this fashion, we note that if (97) were a rule of the grammar, the derivation of (100b) from (103) could be accomplished by an NP movement rule as indicated in (104). Such a rule is clearly structure-preserving in its own right, since it fills an empty NP with an NP from another position.

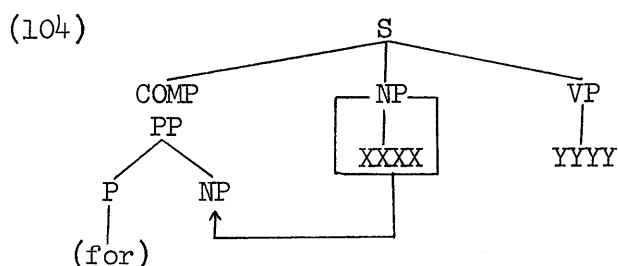

The P in (104) can be taken to be empty before infinitive formation operates; for can be inserted either as part of this rule, just as there might be inserted as part of indefinite subject movement, or it may be inserted at a later point in the transformational derivation.

Up to this point, I have given no evidence that (97) is in fact a rule of the grammar. I have just shown that, given its correctness, it can be utilized to formulate infinitive formation (the derivation of (100b) from (103)) in a straightforward and structure-preserving fashion.

However, there are two very specific empirical consequences of this formulation of infinitive formation, given the structure-preserving hypothesis. It should be recalled that the conventions of Chapter II on generating empty nodes in deep structure and on leaving behind empty nodes after a deletion rule (such as Equi-NP deletion, which can remove the subject of an infinitive) imply that any S whose subject NP undergoes infinitive formation has a PP under COMP at every stage of the transformational derivation from deep to surface structure. (It is empty in deep

structure, and may be empty in surface structure if Equi-NP deletion applies.)

(a) In particular, this PP, present under COMP throughout the transformational derivation, takes up the position for fronted wh constituents and rules out the possibility of a wh-fronted NP. Thus, any infinitive with a possible for phrase subject which is also a wh construction should not exhibit a wh-fronted NP. The only such infinitives are relative clauses;\* indirect question infinitives (to which we return below) never have a for phrase subject, so there is no reason to assume that they undergo infinitive formation as in (104). And, as predicted, an infinitival relative clause can have a wh-fronted PP, but cannot have a wh-fronted NP.

(105) I found an usher from whom you should buy tickets.  
I found an usher who (that) you should buy tickets from.

I found an usher from whom to buy tickets.  
\*I found an usher who to buy tickets from.

Some tools with which you can fix the table will soon arrive.  
Some tools which (that) you can fix the table with will soon arrive.

Some tools with which to fix the table will soon arrive.  
\*Some tools which to fix the table with will soon arrive.

John works for the firm which (that) we should consult in this matter.  
\*John works for the firm which to consult in this matter.

According to the convention of multiple constituents first introduced in section II.6, it is possible that intermediate (but not surface) structures of infinitival relative clauses have more than one constituent

---

\* I am referring to the subordinate infinitive clauses in (105) as "relative clauses". Perhaps they should be derived from some other source; the only relevant point is that wh fronting applies in them.

under the node  $\begin{matrix} \text{COMP} \\ \text{PP} \end{matrix}$  in the same phrase structure position. Thus, the examples of (105) imply nothing about whether or not Equi-NP deletion (which makes a wh-fronted PP in surface structure possible) precedes wh fronting.

(b) If Equi-NP deletion does not apply in an infinitival relative clause, the unremoved for phrase subject should take up the COMP position in surface structure. In such clauses, therefore, it should be impossible for any NP or PP to undergo wh fronting. (In terms of the analysis of relativization given in section IV.2.1, relativization can either remove an NP or leave a pronoun copy for an NP which is subsequently wh-fronted; this means that the latter option is excluded in infinitival relative clauses with expressed for phrase subjects.) This prediction is also borne out.

- (106) I found an usher for you to buy tickets from.  
 \*I found an usher who for you to buy tickets from.  
 \*I found an usher from whom for you to buy tickets.

Some tools for you to fix the table with will soon arrive.  
 \*Some tools which for you to fix the table with will soon arrive.  
 \*Some tools with which for you to fix the table will soon arrive.

Thus, the particular grammatical characteristics of infinitival relative clauses, as exhibited in (105) and (106), indicate that the PP position of the for phrase subjects under COMP directly limits the fronting of wh constituents into this position in accordance with the constraints and conventions of the structure-preserving framework. In the absence of some insightful alternative explanation to the facts presented in (105) and (106), this is evidence in favor of a structure-preserving formulation of the wh fronting rule (i.e., in favor of incorporating the S expansion rule (97) into the grammar).

It is important to note that other embedded infinitives which have fronted wh constituents (i.e., indirect questions) do not exhibit the limitations of infinitival relative clauses:

- (107) I asked John who to consult about this matter.  
 They told us what firm to buy tickets from.  
 The question of how many renters to take in is difficult.  
 She wasn't sure about how to move the table.

I attribute this to the fact that such infinitives never have for phrase subjects; thus there is no reason to assume that they undergo the rule of infinitive formation represented in (104). Either they are directly generated as infinitives in the base, or else they undergo Equi-NP deletion while the subject NP is still immediately dominated by S.

- (108) \*I asked John who for them to consult about this matter.  
 \*They told us what firm for the company to buy tickets from.  
 \*The question of how many renters for an older landlord to take in is difficult.  
 \*She wasn't sure about how for them to move the table.

Since these infinitives do not necessarily have a PP under COMP throughout the transformational derivation, any wh constituent is free to undergo wh fronting.

Concerning indirect questions in general, I have not been able to isolate any specific data which favors or damages the structure-preserving analysis of wh fronting suggested by the above investigation of relative clauses. Nonetheless, a definitive structure-preserving formulation of wh fronting would require an explanation of certain facts about indirect questions which at present eludes me. These facts concern not the internal structure of indirect questions (at least superficially they do not seem to), but rather the distribution of this construction.



The preliminary generalization about the distribution of indirect questions (IQ) is that it is closer to NP distribution than to S distribution.

- (109) S: The denial that John was guilty.  
\*The denial of that John was guilty.
- NP: \*The denial John's guilt.  
The denial of John's guilt.
- IQ: \*The question why John feels guilty.  
The question of why John feels guilty.
- S: They agreed that they should leave.  
\*They agreed on that they should leave.
- NP: \*They agreed a departure time.  
They agreed on a departure time.
- IQ: \*They agreed when they should leave.  
They agreed on when they should leave.
- S: I am aware that he owns several houses.  
\*I am aware of that he owns several houses.
- NP: \*I am aware his extensive holdings.  
I am aware of his extensive holdings.
- IQ: \*I am aware which houses he owns.  
I am aware of which houses he owns.
- S: It doesn't mean much to our children that there is  
widespread unemployment.  
That there is widespread unemployment doesn't mean much  
to our children.
- NP: The widespread unemployment doesn't mean much to our  
children.  
It doesn't mean much to our children, the widespread  
unemployment. (comma required)
- IQ: How many people are unemployed doesn't mean much to our  
children.  
It doesn't mean much to our children, how many people are  
unemployed. (comma required)

Since I have not been able to explain this discrepancy between indirect questions and other embedded S's in an enlightening fashion, I cannot

give a thorough account of wh fronting at this time. However, the evidence of (109) would not seem, on the surface, to argue against the structure-preserving analysis of wh fronting given above.

It seems reasonable to conclude, then, that wh fronting, like other major constituent movement rules which operate in embedded sentences, is structure-preserving.

IV.5 Complex NP Shift A counter-example to the structure-preserving constraint as I have formulated it here is the rule of complex NP shift discussed in Ross (1967). The rule relates the pairs in (110).

- (110) I've sent every letter I ever received to my lawyer.  
I've sent to my lawyer every letter I ever received.
- They brought the robe I had asked for into my room.  
They brought into my room the robe I had asked for.
- She presented a plan for redistributing the land before the council.  
She presented before the council a plan for redistributing the land.

This rule moves object NP's to the end of the verb phrase if they dominate an S. In some cases, it is sufficient that the NP dominate a PP. (When, if ever, the rule is obligatory is not of interest here.) The structure in a typical example in (110) after this rule has applied is as in (111).

- (111)
- 
- ```

graph TD
  VP --> V
  VP --> PP
  VP --> NP
  
```

Since the sequence "V - PP - NP" is not generable by the phrase structure rules of English (i.e., since no empty NP is generable after PP's in a VP), this rule is not structure-preserving.

On the other hand, it does not seem to be an accident that the

condition on complex NP shift is that the NP dominate an S (or PP), and that the NP in question is moved to the S (or PP) position at the end of the VP. Thus, this counter-example to our present formulation of the structure-preserving constraint may in fact lead to a refinement of this constraint which is more accurate. For it may be that the complex NP is moved along with the S embedded in it, and that the latter is moved to the S position at the end of the VP in structure-preserving fashion, as in (112).

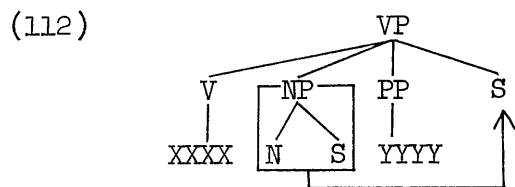

The appropriate revision of the structure-preserving constraint would state that under certain conditions, a node X (S or PP in this case) may move to another phrase structure position for X, but may or must "bring with it" a larger constituent (NP in this case). The conditions under which this may happen and which constituents may be affected I cannot begin to answer here. If these conditions cannot be stated with generality, the structure-preserving hypothesis loses plausibility; on the other hand, it may be that a rule like complex NP shift which violates the structure-preserving constraint as stated here should be considered as part of the semi-grammatical processes which are more in the domain of grammatical performance than of grammatical competence.

## CHAPTER V: MOVEMENTS OF NON PHRASE NODES

In this chapter, movement rules which do not apply to phrase nodes will be investigated. As far as I know, phrase nodes are the only nodes in the phrase structure rules which are never pre-terminal symbols, so that we will in effect be discussing transformations which move pre-terminal symbols. (The phrase nodes are S, NP, VP, PP, and AP; the further possibility of a phrase node NOM was discussed in section II.6.)

We will see that some of the non-root transformations which move pre-terminal symbols are structure-preserving, and that some are not. This means that we cannot simply require that all transformations are either root transformations or structure-preserving transformations.

On the other hand, we can still formulate the structure-preserving constraint in an empirically interesting way, because strong restrictions can be placed on the class of movement rules which are not root or structure-preserving rules. One such restriction (more will be added at the end of this chapter) is that such rules may only reverse the order of two contiguous constituents. Let us call such rules "minor movement rules" and take this as their tentative defining characteristic:

Definition A minor movement rule is a transformation which moves a specified constituent B over a single adjacent constituent C.

An important question is whether we can limit rules which move phrase nodes to the classes of root and structure-preserving transformations. That is, are there minor movement rules which move phrase nodes?

In Chapter II, we saw that dative movement is possibly such a rule. If structure-preserving rules which interchange the positions of two constituents (rather than moving one constituent over another) are not

allowed, then dative movement is not structure-preserving. In any case, however, dative movement interchanges two adjacent constituents, so it does satisfy our preliminary definition of a minor movement rule. But for the present, it seems to me preferable to consider dative movement as a structure-preserving rule which interchanges constituents, as in section II.3.

Another possible minor movement rule which moves a phrase node, as we saw in Chapter III, is the adjective-noun interchange rule. But we also saw that this rule might be structure-preserving, because of the existence of certain classes of pre-nominal adjectives which do not seem to derive from a post-nominal source. Furthermore, even if adjective-noun interchange is not structure-preserving, it might still be the case that the noun N moves over the adjective phrase AP instead of vice-versa.

The uncertainty of these remarks being kept in mind, it nonetheless seems plausible that we can add the following specification to the definition of minor movement rules.

Condition A minor movement rule may not move a phrase node.

We can now state the structure-preserving constraint in final form.

Condition The only non-structure-preserving transformations are root transformations and minor movement rules.

(This statement includes the restriction that insertion as well as movement rules are subject to the structure-preserving constraint. Since deletion rules introduce no new material into a given position in a tree, they are structure-preserving by definition.)

Before examining the class of minor movement rules, I continue with some further examples of structure-preserving rules.

V.1 Structure-Preserving Movements of Pre-Terminal Symbols

V.1.1 NEG Transportation To fix ideas, I will assign NEG (not) a specific position in the phrase structure rules, although the discussion in this section does not depend crucially on what this position is.

For various reasons, it appears that the S expansion rule specifies an optional NEG according to (1a).

(1a)  $S \rightarrow \text{COMP} - \text{NP} - (\text{AP}) - \text{TENSE} - (\text{M}) - (\text{NEG}) - (\text{EMP}) - \text{VP}$

One reason for generating NEG outside the VP is that it does not delete when VP does.

(1b) Bill came early, but Mary did not.  
Ellen refuses to buy grapes, and I try not to.

EMP represents the emphatic particles so, too and (after n't) either.

If these particles were dominated by VP, we could not explain why they never occur in non-finite clauses (gerunds, infinitives, and participles) or why they do appear in clauses where VP is deleted:

(1c) Bill should too buy this book.  
Mary did so say they would come.  
John didn't either send me a postcard.  
  
Bill came early, and Mary did too.  
Bill came early, and so did Mary.  
John doesn't buy grapes, and Mary doesn't either.  
John doesn't buy grapes, and neither does Mary.

Another reason for generating a NEG under S is the fact that n't precedes this either (i.e., EMP), which we have just seen precedes VP.

Why not follows rather than precedes have (auxiliary usage) and be will be explained in section V.1.3; for the moment, the grammar generates

not and these elements in the wrong order, since these auxiliaries originate in deep structure under VP.

The rule of NEG transportation, first discussed by Klima (1964), derives the second sentences (or at least one reading of the second sentences) in the pairs of (1d) from the first sentences.

- (1d) John might believe that Mary didn't pass the course.  
 John might not believe that Mary passed the course.
- John seems not to read much.  
 John doesn't seem to read much.
- We expect them not to be too happy about it.  
 We don't expect them to be too happy about it.

(The TENSE movement rule and the rule which determines the distribution of the auxiliary do are also involved in (1d); they will be discussed in the next section.) The effect of NEG transportation in the first example of (1d) is indicated by the arrow in (2).

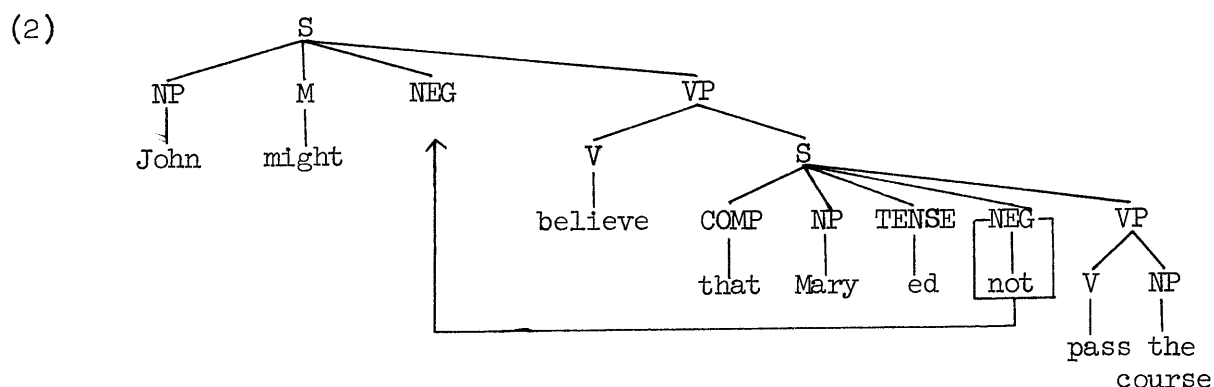

If NEG transportation exists as a transformational rule, it is clearly structure-preserving; i.e., the not is not moved to some arbitrary position within the higher sentence, but to the very position ordinarily assigned to not by the phrase structure rule for VP expansion.

Klima (1964) pointed out that the syntactic arguments favoring NEG transportation face certain difficulties due to the fact that the complement S's of predicates such as to doubt and to be unlikely share many of the "negative context" characteristics of the complements to not believe, not seem, etc. (Cf. "I doubt that he'll come until six.") I will not try to resolve these difficulties here, even though it might be necessary to abandon a NEG movement rule in order to do so. Until such an alternative can be definitely rejected, I can only make a conditional conclusion; if NEG transportation is a transformation, it is an example of a structure-preserving movement rule which affects a pre-terminal symbol.

A word on a class of apparent exceptions to the usual pre-main-verb position of not in English is perhaps in order.

- (3)        I think not.  
              I think so.
- She hopes not.  
              She hopes so.
- If so, I'll be happy to come.  
              If not, I'll be happy to come.

A plausible explanation for this class of exceptions has been advanced by Lakoff (1966). He proposes that the so and not in (3) are pro-forms for deleted (understood) sentence complements of think, hope, and if. Whether so or not appears in surface structure depends on whether or not the deleted sentence contains not. Thus, when an S complement is deleted, a grammatical marker indicating whether it is asserted or denied in deep structure appears in surface structure.

According to this explanation, "I think not" and "I don't think so"



result from the same deep structure; the former is obtained when NEG transportation does not apply before the understood complement S is deleted, and the latter is obtained when NEG transportation does apply (moving not out of the complement and leaving a positive assertion). The sentences of (3) and Lakoff's explanation of them do not constitute a definitive argument in favor of NEG transportation (over the difficulties observed by Klima), however.

V.1.2 Affix Movement The verbal affixes in English (s/φ, ed, ing, en) have several different deep structure and transformational sources (which will be discussed below), but they invariably appear in surface structure as suffixes on verbs. I will argue in this section that the structure-preserving hypothesis allows us to account for this surface-structure restriction in a natural way.

In section II.2.2, I argued that each auxiliary which appears in infinitives and other non-finite constructions is the head of a separate VP. Accepting this, if we assign the verbal affixes ing and en to a category AF, and if we generate the progressive morpheme pair be-ing and the perfective morpheme pair have-en as in Chomsky (1957), the VP expansion rule should be modified to (4).

$$(4) \quad \text{VP} \rightarrow (\text{AP}) - \underset{\text{(AUX)}}{\text{V}} - (\text{AF}) - \dots *$$

---

\* It is no doubt true that AF is dominated by V in surface structure. There is probably a general rule or convention by which AF and similar suffixal elements are attached to the preceding pre-terminal node as follows:

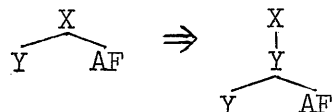

We saw in Chapter III that the VP complements to verbs of temporal aspect (begin, start, continue, cease, resume, etc.) which are introduced by ing are not NP's. (Arguments for this included consideration of the behavior of these complements vis-à-vis the passive rule and the cleft transformation.) I will assume that the ing on the heads of these complements, like the ing on the head of a complement to a progressive be, is generated in deep structure as a sister constituent AF to the verb which governs it. In this view, the underlying structures of two phrases like "be playing" and "finish playing" are as in (5).

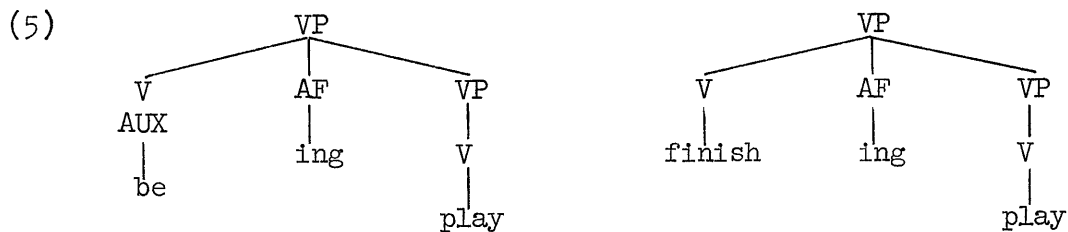

On the other hand, I do not attribute the ing which introduces gerund NP complements such as those underlined in (6) to the AF in (4), since I showed in Chapter III that all NP's which are S's are gerunds (i.e., they all have an ing suffix on the highest verb). This means that ing is simply due to the configuration  $\begin{array}{c} \text{NP} \\ | \\ \text{S} \end{array}$ , and not to some added sub-categorization of the governing verb:

- (6) Bill enjoyed playing the trumpet.  
 Mary's being absent disturbs me.  
 They were counting on Bill's knowing the area.

---

(footnote cont.)

In the text, I will be concerned only with determining the correct positioning of various instances of AF in surface structure, and will assume that some formal device of this sort derives the correct surface structure dominance relations.

Rule (4), in conjunction with the structure-preserving constraint, explains why the NP preposing (passive) rule inserts a morpheme pair be-en into a position typical of such elements and not into arbitrary positions (after the main verb, before the subject, etc.). That is, NP preposing inserts this auxiliary-affix pair into the empty nodes circled in (7), yielding "Mary was insulted by Bill."

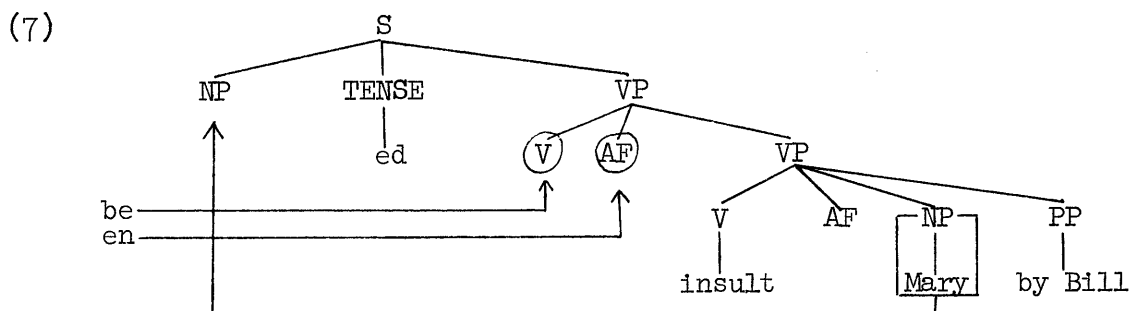

In the discussion of adjective-over-noun movement (section IV.1.1), we saw that the ing which introduces participles is not the ing of the progressive form. By similar reasoning, neither is the ing that marks the gerund. (This ing appears on stative verbs, on the auxiliary have, etc.) Now these two instances of ing in participles and gerunds may be directly inserted into the proper surface structure positions, or they may be moved into these positions by a movement transformation; in either case, the fact that these ing's occupy the same post-verbal position as other AF's is also predicted by the structure-preserving constraint.

The affix movement rule, first formulated by Chomsky (1957), moves the affixes ing and en one AF position to the right, as in (8). Again, the structure-preserving constraint predicts that any movement of AF can only be to another phrase structure AF position.\*

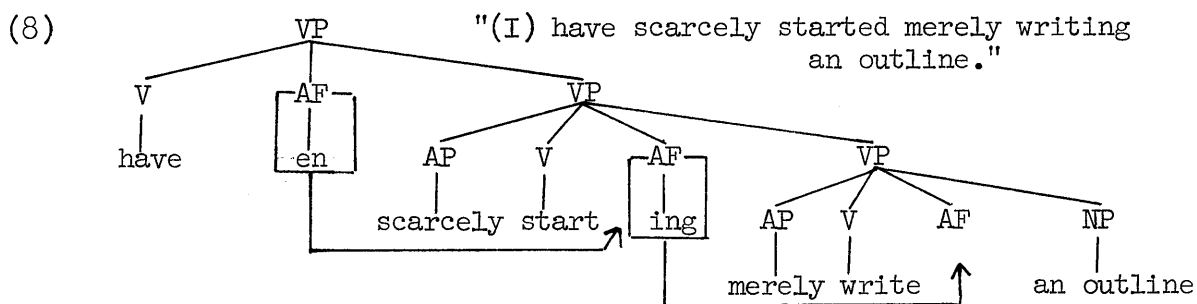

(Affix movement either precedes the insertion of ing in gerunds and participles, or else these ing's originate to the left of the verbs which in surface structure precede them, and are themselves moved by affix movement.)

It is well-known that TENSE (s/∅ and ed) appears in surface structure as a suffix on the first verb of the VP (i.e., in AF position) in S's which lack a modal M or the auxiliary do. If we assign the feature AF to TENSE, the structure-preserving constraint in fact predicts that

---

\* Affix movement cannot be stated as a minor movement rule over a single constituent, since the affixes move over adverbs as well as verbs, as in (8). Thus, the structure-preserving constraint does not allow an alternative formulation of affix movement as a non-structure-preserving rule.

Throughout the paper, I have noted several instances of empty nodes in deep structure in positions where non-empty nodes would be excluded by sub-categorization features (although generable, of course, by the phrase structure rules). The empty node in (8) and the non-circled AF node in (7) are just further instances of this phenomenon.

Affix movement demands some convention on the applicability of transformational rules, so that it can apply more than once in a given S. One possible convention is that it iterates, scanning the terminal string from right to left for two successive AF positions.

TENSE could move to no other position except the AF position. An example of TENSE movement is given in (9).

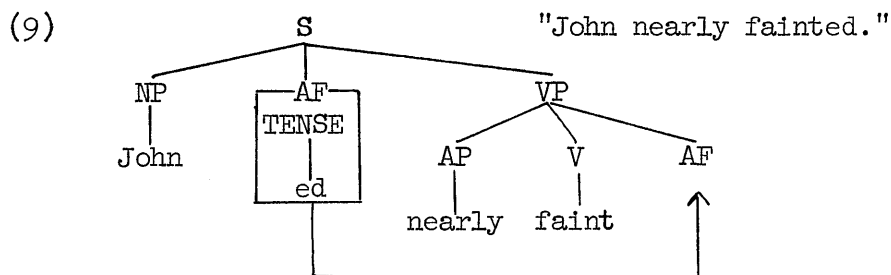

There would be no need for a separate feature TENSE (distinct from AF) at all if the choice between s/∅ and ed on the one hand and ing and en on the other could be made to depend on whether S or VP immediately dominated AF in deep structure. However, I will retain TENSE here, at least for the sake of clarity.

The correctness of analyzing TENSE as AF is confirmed by the fact that affix (ing and en) movement and TENSE movement can be written as a single AF movement rule, as in (10).

(10) X - AF - Y - AF - Z → 1 - ∅ - 3 - 2 - 5, where Y does not dominate AF.

Before we can leave the affix movement rule (10), we must add a condition to it. In section V.1.3 I will discuss criteria which show that the auxiliaries be, do, and have which immediately follow the subject NP are in the M position in surface structure, even though most uses of be and have are V's in deep structure. (That is, they are immediately dominated by VP, since they can appear in infinitives, gerunds, participles, and after modals.) There are also modal usages of be and have which are generated in M position in deep structure, such as those underlined in (11). In these usages be and have are modals because such constructions



- (13) John did faint.  
 \*John did faint. (did unstressed)  
 \*John did merely wave. (did unstressed)  
 John did not faint.  
 John didn't wave.  
 Why did John faint?  
 John did so faint.  
 John did too wave.

The elements which permit an unstressed do to precede them, as in (13), are just these which we know are outside the VP following this do. The reasons why NEG and EMP (the emphatic particles) should be generated outside VP were given in V.1.1. We also know that an inverted subject NP is outside the VP because the rule which causes the inversion is a root transformation and so could not place a constituent under a VP. This means we can formulate an obligatory do deletion rule as in (14) (do deletion precedes AF movement.)

- (14)  $X - [{}_M \underline{do}] - AF + VP + Y \Rightarrow 1 - \emptyset - 3$ , where do is not contrastively stressed.

Since a condition on affix movement is that AF can move only if a M does not immediately precede it, the deletion rule (14) in effect permits the TENSE affix to move only if do is deleted. That is, AF can move onto the main verb just in case the latter is not preceded by an inverted subject NP, NEG, or EMP. (Recall that I revised the S expansion rule to make M obligatory.) This prediction is exactly right:

- (15) John (merely) fainted.            \*John waved not.  
 \*John not fainted.                \*Why waved John?  
 \*Why John fainted?                \*John too waved. (where too ≠ also)  
 \*John so fainted.

The reason why do never precedes the auxiliaries have and be which are

dominated by VP in deep structure will be given in the following section.

In conclusion, the structure-preserving formulation of AF movement explains why the deep structure positions of ing and en, the position of en inserted by NP preposing, the surface structure positions of those cases of en, ing, s/ø, and ed which originate in deep structure, and the surface positions of the ing associated with gerunds and participles are always fixed post-verbal (and post-modal) positions.

V.1.3 AUX Movement In Chapter I, I defined the clause constructions traditionally termed infinitives, gerunds, and participles (excluding their subjects) to be VP's. By this definition, material which may follow a modal (M) (except EMP and NEG) in a full sentence is a VP. Under this assumption, be and the auxiliary have are generated under VP in deep structure, since they can follow modals and since they occur in non-finite clause constructions. (I am not referring here to the modal uses of be and have exemplified in the expressions be to, be going to, and had better, which were discussed in the preceding section.)

However, be and the auxiliary have behave differently than ordinary verbs in many ways; the purpose of this section is to account for this behavior in a simple manner, and to see if any structure-preserving rule emerges from this account.

The basis of the analysis is the assignment of the feature AUX to just these elements.\* Earlier in this paper, a minor use of this feature

---

\* I have not been able to isolate any serious empirical differences between the following three options: i) AUX is a feature that co-occurs with V. ii) There is a phrase structure rule  $V \rightarrow \text{AUX}$ , and the only AUX's are have and be. iii) The phrase structure rule expanding VP gives an optional choice between AUX and V. The seeming equivalence of the three options is in part due to the formulation of AF movement given as (10), which does not mention the categories V or AUX. For purposes of exposition, I have arbitrarily chosen (i) in the text.



was mentioned: the NP preposing (passive) rule moves an object of a verb into the subject position, provided no other verb intervenes between the subject and this verb; however, an AUX may so intervene. That is, NP preposing moves an NP over X-V, where X does not dominate  $\left[ \begin{array}{c} V \\ -AUX \end{array} \right]$ .

The principal characteristic of AUX verbs that differentiates them from ordinary verbs is that they act like modals when they immediately follow the subject NP. For example, the subject NP is inverted around a modal in questions, but not around a main verb. (Alternatively, one could say the modal moves around the subject NP.)

- (16) Will John help him?  
 Why did the boy leave?  
 \*Refuses John to help him?  
 \*Why left the boy?

But if the first verb after the subject is be or the perfective have, these also invert:

- (17) Was John helping him?  
 Why had the boy come?

In conjunction with this fact, note that the auxiliary do does not precede AUX verbs as it does ordinary verbs.\*

- (18) \*Did John be helping him?  
 \*Why did the boy have come?  
 \*John did be helping him.  
 \*The boy did have come.

---

\* I am not speaking here of the emphatic do of imperatives, which seems to be derived from a deep structure will after the operation of the AUX movement rule discussed in the text. Cf. "Do come in, won't you," "Do be more polite, will you," etc.

These two facts can be accounted for by an AUX movement rule which obligatorily replaces the modal do with a following AUX verb, as in (19).

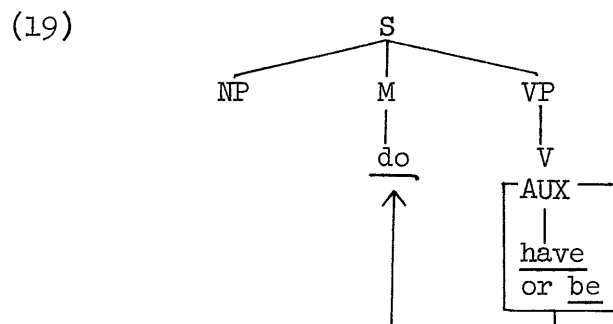

(The formal question of whether V is moved with AUX in (19) is considered below.)

According to (1a), the NEG and EMP particles can follow M but not V. The AUX movement rule correctly predicts that these particles will follow the first be after a subject and any use of have which inverts in questions. (In my dialect, only the perfective have and had better have this property.)

- (20) (a) The children mustn't play in the streets.  
 They did not get examined.  
 You could too take that with you.  
 John does so know French.

\*The children playn't in the streets.  
 \*They got not examined.  
 \*He took too that with him.  
 \*John knows so French.

The children aren't in the streets.  
 They were not examined.  
 John has not followed directions.  
 Bill has so seen a doctor.

\*John has not a maid come in on Saturdays.  
 \*Bill has so to see a doctor.

In contrast to the preceding, recall that in present subjunctives, in which M is deleted (making AUX movement impossible), not precedes be, as predicted by (1a).

- (20) (b) She requests that they not be examined.  
 \*She requests that they be not examined.  
 It is of great importance that the children not be in the street when he comes.  
 \*It is of great importance that the children be not in the street when he comes.

We know that certain classes of adverbs can appear at the beginning of the VP, i.e., after M. (Cf. section IV.1.2.) These adverbs cannot come between a verb and a following predicate attribute or object NP, however.

- (21) I wonder if they could ever buy a car.  
 \*I wonder if they bought ever a car.  
 John does frequently visit his parents.  
 \*John visits frequently his parents.  
 Mary can barely speak French.  
 \*Mary speaks barely French.
- Did Mary suddenly become a radical?  
 \*Mary became suddenly a radical.  
 I may already look fat.  
 \*He looks already fat.

The AUX movement rule correctly predicts that such adverbs may follow be and the auxiliary have, but not non-auxiliary have.

- (22) I wonder if he was ever a radical.  
 He has frequently visited his parents.  
 Mary was suddenly a radical.  
 I am already fat.
- \*He has frequently to visit his parents.  
 \*They have frequently a maid come in.

In section V.2, I will discuss a quantifier postposition rule by which the determiners all, each, and both may appear after the modal M. (These determiners have their deep structure source in the subject NP.) However, they may not appear after a verb V under the VP.

- (23) You would all enjoy a movie.  
 \*We enjoyed all a movie.  
 They didn't both enter the store.  
 \*They entered both the store.  
 They should each buy lots of books.  
 \*They buy each lots of books.

Again, the AUX movement rule predicts that these determiners can follow a be or an auxiliary have which follows the subject NP:

- (24) We were all enjoying a movie.  
 They have both entered the store.  
 They are each avid readers.  
 \*They had both two steaks brought in.  
 Cf. They both had two steaks brought in.

In tag S's, as exemplified in (25), the VP is deleted. This VP deletion precedes deletion of unstrressed do, so that the latter appears in tag versions of sentences without other auxiliaries:

- (25) His son may not drive a car, may he?  
 \*His son doesn't drive a car, drives he?  
 His son doesn't drive a car, does he?  
 Susan sees movies as often as she can.  
 \*Susan sees movies as often as Bill sees.  
 Susan sees movies as often as Bill does.

By ordering the AUX movement rule before VP deletion, we can account for the appearance of be and the auxiliary have in tags, and for the fact that do does not "substitute" for them as in (25).

- (26) The reason is that he drove too fast, isn't it? (\*doesn't it?)  
 Susan has seen this movie as often as Bill has. (\*does)  
 Cf. John always had to take pills, didn't he? (\*hadn't he?)

(As expected, the non-auxiliary have does not appear in tag S's.)

In a study of contractions of auxiliaries, Zwicky (1969) has found

that the initial phonological grouping "optional consonant - vowel" of will, would, have, had, has, is, am, and are can be dropped after pronominal subjects. (Has and is can be contracted elsewhere as well, but this is not of interest here.) However, the contraction may apply to forms of have, according to Zwicky, only in those usages of have which can invert in questions. For example, in all dialects studied, the perfective have and the modal had better invert in questions and may contract. On the other hand, the causative have and the have of obligation invert in no dialect, and also never contract.

- (27)        \*Have they to take lots of pills?  
              \*They've to take lots of pills.
- \*Have they a maid come in?  
              \*They've a maid come in.

Just in the dialects where a simple transitive have may invert in questions, Zwicky claims, a simple transitive have may contract; that is, the examples of (28) are equally grammatical in any dialect.

- (28)        ?Have you many books?  
              ?You've many good books, I know.

Given the AUX movement rule, we can make the contraction depend on have, will, or be being in the M position (i.e., not dominated by VP), and thus explain the correlation noted by Zwicky.

This concludes my justification of the AUX movement rule; we must now ascertain if the AUX movement rule is structure-preserving.

One line of argument which might be pursued (though I will not adopt it here) is that V and M are actually the same category for purposes of the structure-preserving constraint. The fact that VP's and S's have

similar surface distribution suggests that closer investigation might reveal that these two nodes are treated as a single category in transformations and/or in the phrase structure rules, just as NP's which have head nouns and gerund NP's are. Since V and M are respectively the heads of VP and S, and since I require that the category of a phrase node uniquely determine (cf. section I.1) the category of its head, it would follow that M and V would be the same node vis-à-vis the structure-preserving constraint if S and VP were the same node.

However, I do not think it is necessary to establish the above (although it would be sufficient) in order to show that AUX movement is structure-preserving. Even if M and V are distinct categories, there is a non ad hoc way to formulate AUX movement as structure-preserving.

I mentioned in section V.1.2 that the only M's which exhibit the third person singular verbal s or es ending are the auxiliary do and the modal be in the expressions is to (obligation) and is going to. This means that the grammar must contain a rule (29) to differentiate the modals which take s from those that don't.

(29)  $s/\phi \rightarrow \phi / \left[ \begin{array}{c} M \\ +F \end{array} \right] \text{---}$ , where only do, be and have are -F.

Now, we can eliminate one feature in the grammar by identifying +F as -AUX. That is, if we analyze the modals do, be, and have as +AUX, we can use the same feature in (29) as in the AUX movement rule. Moreover, this choice makes AUX movement itself structure-preserving, in that it operates as in (30). (No formal difference between features and nodes is being assumed in this study; "node" is simply a convenient way of designating "principal (or only) feature associated with a branch point or a terminal point in a tree.")

(30)

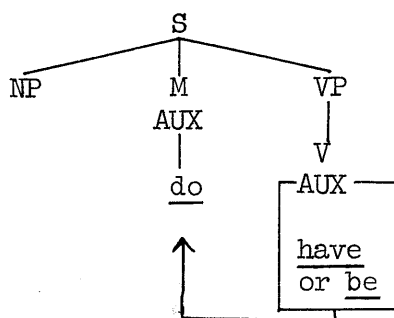

A further consequence of identifying the F in (29) with -AUX is that be is then the only verb in English which is in every usage +AUX. Whether this fact can be used to advantage in specifying the special idiosyncratic forms of be (was, were, am, are) in the lexicon, or for some other purpose in the grammar, I cannot say with certainty here.

One might ask if the AUX moved in (30) is associated with the **feature** M or the feature V in derived structure. Various transformations which move NP's in and out of the possessive ('s) position inside NP's are instructive in this regard. For example, the possessive NP's Russia and a boy in "Russia's defeat of Germany" and "a boy's growth" occur with the feature ±DEF under DET, yet there is little reason to suspect that the feature ±DEF is present with these NP's in the derived phrases "The defeat of Germany by Russia" and "the growth of a boy." In fact, it seems that DEF is specifically "left behind" and causes the subsequent insertion of the. Because of considerations like these, I assume that the V in (30) is "left behind" by AUX movement and that the auxiliaries has, is, are, etc. are dominated by M in surface structure.

One would certainly not want to base the structure-preserving hypothesis on arguments as weak as the one made here that AUX movement is structure-preserving. (If one could show that S = VP and hence that M = V for purposes of transformations, then in fact AUX movement would be

strong support for the structure-preserving constraint.) However, the small advantages of a structure-preserving formulation of AUX movement should not be overlooked, in view of the fact that numerous other rules give the structure-preserving constraint a high credibility.

#### V.1.4 Some Considerations on Clitic Placement in French and Spanish

Perlmutter (1968) has shown that conditions on transformations cannot adequately express the ordering restrictions on unstressed pre-verbal "clitics" in French and Spanish, and that these clitics must be independently subject to a "surface structure constraint" which determines their order relative to one another. (In Spanish, the clitics can follow the verb in infinitives and participles. I return to this point later.)

Perlmutter shows in some detail that such surface structure constraints have formal similarities to phrase structure rules. For one thing, he showed that surface structure constraints specify combinations of elements which may occur, rather than combinations which may not. For another, he showed that they consist of linear sequences of elements which can be abbreviated by the parenthesis and bracket notations also used in phrase structure rules. The permitted sequences of pre-verbal clitics in Spanish and French are to be stated, following Perlmutter (1968), as follows. (REF = reflexive, SUB = subject forms, ACC = accusative forms, II = second person, etc.)

(31) (REF) - (II) - (I) - (III) (Spanish)

(32) (SUB) - (NEG) - (  $\left\{ \begin{array}{c} \text{I} \\ \text{II} \\ \text{REF} \end{array} \right\}$  ) - (  $\left[ \begin{array}{c} \text{III} \\ \text{ACC} \end{array} \right]$  ) - (  $\left[ \begin{array}{c} \text{III} \\ \text{DAT} \end{array} \right]$  ) - (Y) - (EN)  
(French)



Perlmutter argues that clitics cannot be generated by phrase structure rules, but it is clear from the arguments that he means that clitics cannot be generated in their surface positions in deep structure. Once we have the notion of a structure-preserving constraint on transformations and the concept of empty nodes in deep structure, Perlmutter's surface constraints can be handled in the same way as the restriction in English that AF always follow a verb. We simply incorporate (31) and (32) into the right-hand side of the phrase structure rules which expand VP:

(33) VP → (REF) - (II) - (I) - (III) - V - ... (Spanish)

(34) VP → (SUB) - (NEG) - ... - (EN) - V - ... (French)

As Kayne (1969) has pointed out, the pre-verbal clitics, like AF in English, should be immediately dominated by V at least in surface structure; I return to this point below.

The clitic nodes (features) in (33) and (34) are generally empty in deep structure because there are few sub-categorization features on the following verbs which demand preceding particles, and few projection rules or other semantic devices which interpret pre-verbal particles which are generated freely. In the same way, a deep structure AF dominated by VP in English is almost always empty; only the progressive be, the perfective have, and the verbs of temporal aspect are sub-categorized to take a deep structure AF sister (ing or en).

In fact, the pre-verbal clitic nodes given by (34) for French are not always empty. There would seem to be little reason to generate the negative particle ne in any other position besides that given in (34). (This does not exclude the possibility of a NEG transportation rule in

French whereby a NEG generated by (34) in one VP moves into the NEG position in another VP.) Kayne (1969) has gone to some length to show that the se (REF) which appears with a certain productive class of impersonal verbs is also generated in pre-verbal position in deep structure.\*

There are certain ambiguities inherent in simply imposing (31) and (32) as surface constraints on the order of clitics in Spanish and French that can be resolved naturally by considering these constraints as part of the phrase structure rules. For example, these constraints apply only to sequences of clitics immediately dominated by the same node.\*\* The underlined sequences in (35), in which the clitics are immediately dominated by different nodes, are perfectly acceptable even though the order required by (31) is broken.

- (35) EL hombre que quiere lavar-se se fue'.  
 EL hombre que quiere besar-la me lo dijo.

One could, in a grammar without the structure-preserving constraint, require that surface structure constraints apply only to sister constituents. But this is just another way in which such constraints formally resemble phrase structure rules (which specify the order of sister constituents) and another reason for simply expressing the former as part of the phrase structure rules in a grammar with the structure-preserving

---

\* Recall that the structure-preserving formulation of wh fronting in English (section IV.4) includes the notion of generating nodes under COMP which are never non-empty in deep structure.

\*\* Kayne (1969) has shown that the subject pronoun clitics in French are immediately dominated by the same node as the other clitics, the V node. At this point, my analysis has the French clitics being immediately dominated by VP, but this will be remedied below.

constraint and empty nodes.

It is also not clear that surface structure constraints in Perlmutter's original sense can naturally express the restriction that movement rules must move clitics to the positions specified in (33) and (34). A theory of grammar without the structure-preserving constraint but with surface structure constraints on the ordering of clitics would supposedly permit a language A identical to French except that the particle en is placed in pre-verbal position only if it originates to the left of the verb, and that en is placed to the right of the verb phrase if it originates to the right of the verb. Language A would then have grammatical judgments as in (36), where % indicates ungrammaticality in A.

- (36) Le dehors de cette maison est laid, mais le dedans en est joli.  
 %Je n'en aime pas le dehors.  
 Je n'aime pas le dehors en.  
 %J'en étais très fier.  
 J'étais très fier en.

A surface structure constraint demands that a pre-verbal en follow all other clitics in French, but it does not ensure that any rule producing the clitic en will move it into pre-verbal positions. On the other hand, interpreting surface constraints as parts of the phrase structure rules and imposing the structure-preserving constraint on grammars excludes in principle a language like A.

If surface structure constraints are part of the phrase structure rules, any movement rules which place clitics where such clitics are not specified in the phrase structure rules should be root transformations or minor movement rules. In Spanish, clitics can precede or follow the main verb in embedded infinitives and participles. This indicates the need

for a minor movement rule which moves a single constituent B over a single constituent C. However, according to (33) and (34), the clitics are not in themselves a single constituent. In order to make the statement of such a rule possible, I revise (33) and (34) to (35) - (37).

- (35) VP → (CL) - V - ... (French and Spanish)
- (36) CL → (REF) - (II) - (I) - (III) (Spanish)
- (37) CL → (SUB) - (NEG) - (  $\begin{Bmatrix} I \\ II \\ REF \end{Bmatrix}$  ) - ( [ACC] ) - ( [DAT] ) - (Y) - (EN)  
(French)

We can now write a minor movement rule for Spanish which moves CL over V provided the latter does not have a finite ending. I return to this rule briefly in section V.2.5. \*

There are also some instances where clitics appear elsewhere besides in the structures generated by (35) - (37) in French. First, a subject pronoun inverts over a following verb in a direct question.

---

\* Kayne (1969) has argued convincingly that all pre-verbal clitics in French should be dominated by the adjacent V. In this the CL node resembles the AF node in English. In an earlier footnote, I pointed out that some rule or convention should change a deep structure

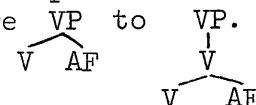

That is, AF has the property that it is the suffix of the preceding pre-terminal symbol, M or V. Similarly, CL in French and Spanish has the property that it is the prefix of the following verb. What the phrase structure rules given here generate as

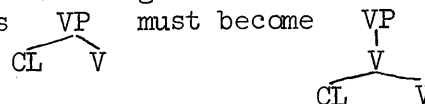

(I understand, though I am not at all competent to comment on such languages, that the clitics in languages like Serbo-Croatian attach to the preceding pre-terminal symbol, which is not the verb, but even possibly the noun of a noun phrase, an adverb, etc. Thus, CL in these languages would be suffixal, like AF in English.)

- (38) Quand parlerez-vous à Jean?  
 Ne s'est-il pas souvenu de nous?  
 Vous y ont-ils ammenés à temps?

However, as Kayne (1969) has pointed out, the rule which causes this inversion does not apply in embedded sentences. (It is not to be confused with a rule which optionally inverts fully specified NP's in questions, which also applies in embedded sentences. The two rules, as Kayne shows, differ in many respects; I return to the full NP inversion rule below.) Thus, pronoun inversion appears to be a root transformation in the structure-preserving framework.\* It is interesting to note that it cannot be expressed as a minor movement rule (i.e., as a movement over a single constituent), as the diagram in (39) shows.

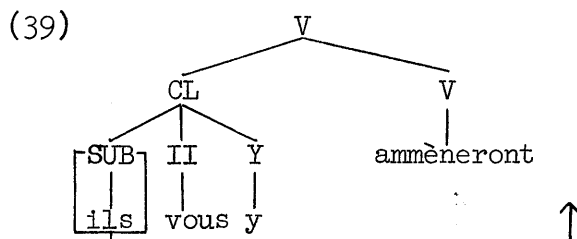

The other instance of clitics appearing post-verbally in French is the affirmative imperative construction.

---

\* The two root transformations discussed here which apply to French clitics indicate that it is not quite correct to require root transformations to attach clitics to the highest S. No non-root S can dominate a clitic moved by a root transformation, but the status of a clitic as an affix somehow overrides the requirement that a root transformation attach a constituent to the root directly. I am not capable of elucidating the exact nature of the dominance relations involving clitics at this time. The main point in the text is that it is striking that the only two violations of pre-verbal clitic positions in French occur in non-embedded sentences. This was pointed out to me by Richard Kayne (personal communication).

- (40)      Donnez-le-moi!  
           Conduisez-les-y dans mon auto.  
           Présentez-la-nous avant le diner.  
           Apportez-les-y-moi plus tard.

Again, this type of sentence cannot be embedded, so a root transformation is involved. And again, it should be noted that the affirmative-imperative construction, like the pronoun inversion in questions, is not adequately describable by minor movement rules. It might be thought at first that two minor movement rules, one an inversion of CL and V and the second the inversion of two clitics, could derive this construction. But in fact, the second inversion must invert elements like moi over a possible sequence of sister clitics, as in (40), so a minor movement rule cannot be used.\*

As Perlmutter has noted, the fact that even the surface structure constraint on the order of clitics is violated in (40) makes it "necessary to discover just what types of rules can apply after the application of surface-structure constraints, constraining this class of rules as much as possible." If we consider Perlmutter's surface structure constraints as part of the phrase structure rules, the structure-preserving constraint automatically provides a necessary condition that such rules must fulfill: they must be minor movement rules (like verb-clitic inversion in Spanish) or root transformations (like pronoun inversion in questions and affirmative imperative inversion in French).

A final word concerns the French "stylistic inversion" transformation

---

\* The appearance of moi rather than me in affirmative imperatives may result from the feature "I" (first person) not being dominated by CL after the appropriate root transformation operates.

studied by Kayne. This rule differs from pronoun inversion in that it is optional, in that it may apply in embedded sentences, and in that it moves a subject NP over both the auxiliary and the following main verb.

- (41) Je me demande quand partira Jean  
 L'homme qu'a vu mon père veut partir.  
 Les étudiants pour qui a été conçu ce cours ne l'utilisent pas.  
 Nous avons oublié pourquoi est parti Pierre avec sa femme.  
 Je vais prendre la table qu'a construite Jean pour Guillaume.

According to the structure-preserving constraint, this rule must be structure-preserving, since the subject NP moves over more than one constituent (it isn't a minor movement rule) and the rule applies in embedded sentences. The fact that for some speakers the rule does not move a subject NP to a position before a PP is not relevant to the discussion here.

The only way that stylistic inversion can be structure-preserving is if it moves the subject NP into the object NP position. Confirmation that this is what happens is provided by the fact that the rule does not apply if a direct object NP follows the verb in surface structure. (The examples of (42) are ungrammatical even in dialects in which all the sentences of (41) are acceptable.)

- (42) \*Quand mangera Jean cette pomme?  
 \*Je me demande comment trouvera Pierre ses livres.  
 \*Les étudiants pour qui a introduit le professeur ce cours  
 ne l'utilisent pas.  
 \*Nous avons oublié pourquoi a acheté Paul ces cadeaux avec  
 sa femme.  
 \*J'ai vu l'homme avec qui a écrit Jean un livre.  
 \*Prenez les outils avec lesquels a construit Jean une table  
 pour sa femme.

I conclude that "stylistic inversion" in French is a structure-preserving NP movement rule, while subject pronoun inversion in questions

is a root transformation.

V.2 Minor Movements of Pre-Terminal Symbols A minor movement rule, as defined at the beginning of this chapter, moves a node B over a node C. The minor movement rules of English which may possibly apply to phrase nodes are dative movement and adjective-over-noun movement. In dative movement, B and C are both NP's. In adjective-over-noun movement, B is an AP (or possibly a VP, as discussed in section IV.1) and C is an N.

The fact that B and C are sisters before the minor movement rule applies in both these instances will be of interest below, when a further restriction is placed on minor movement rules. First, however, let us consider a number of minor movement rules of English which apply to pre-terminal symbols.

V.2.1 DEG Postposing Adjective modifiers generally precede the head adjective of an AP. This includes not only adverbial and noun phrase modifiers, as in surprisingly bold, actually stupid, five miles long, a few days old, etc., but also the characteristically adjectival modifiers very, quite, so, as, how, too, more, and most. But the three adjectival modifier morphemes enough, er, and est (heavy enough, heavier, heaviest) are exceptions to this rule, since they follow the head adjective in surface structure. Thus, one postulates a permutation by which "DEG - A" becomes "A - DEG", where DEG is er, est, or enough only. (I will not deal here with the derived structure assigned by a minor movement rule.) This "DEG postposing" rule is a minor movement rule, in which B is DEG and C is A.



V.2.2 DET Incorporation There is a limited class of deep structure PP's with pronominal NP objects which are transformed into adverbs (intransitive prepositions).

|      |                   |                   |                    |
|------|-------------------|-------------------|--------------------|
| (43) | in this = herein  | in that = therein | in which = wherein |
|      | by this = hereby  | by that = thereby | by which = whereby |
|      | of this = ?hereof | of that = thereof | of which = whereof |
|      | after this        | after that        | after which        |
|      | = hereafter       | = thereafter      | = whereafter       |
|      | upon this         | upon that         | upon which         |
|      | = hereupon        | = thereupon       | = whereupon        |

These adverbs can be derived by a rule of "DET incorporation," which has the form (44).

$$(44) \quad \left[ \begin{array}{c} \text{PP} \\ \text{P} - \text{DET} \end{array} \right] \Rightarrow \begin{array}{c} 2 \\ +\text{LOC} \end{array} + 1 - \emptyset, \quad \text{where DET} = \begin{array}{c} \text{which, this,} \\ \text{or that.} \end{array}$$

(It is probable that  $2 + 1$  in (44) is dominated by P as well as by PP in derived structure, but the derived structure produced by minor movement rules is not at issue here.)

DET incorporation is a minor movement rule in which B is DET and C is P. However, B and C are not sisters when this rule applies. Rather, DET is "in construction with" P, since the NP dominating DET is a sister to P. (Klima (1964) defined a node B to be "in construction with" a node C if and only if the node immediately dominating C, but not C itself, dominates B.) In the minor movement rules previously discussed, B and C are sisters when the rules apply; the relation of being sister constituents is a special case of the relation "in construction with." For convenience, I will say henceforth that B and C are "mutually in construction" if either B is in construction with C or C is in construction with B.

I now place the following restriction on minor movement rules, beyond that of the original definition of this class. If a minor movement rule moves a node B over a node C, then B and C must be mutually in construction. (This restriction says nothing about the derived structures of minor movement rules.)

V.2.3 Particle Movement The category PRT (particle) includes up, down, back, away, in, out, off, on, over, apart, together, and a few others.

I assume that PRT is generated by the VP expansion rule between V - AF and the object NP node. Particles can occur only with certain classes of verbs (discussed in Fraser (1968)), and either they follow the verb immediately or they follow the first NP after the verb. (They never follow a predicate attribute NP, however.)

- (45) They were talking over the situation.  
They were talking the situation over.
- We brought our children back some gifts.  
We brought back our children some gifts.  
\*We brought our children some gifts back.
- The office sent the members out a letter.  
The office sent out the members a letter.  
\*The office sent the members a letter out.
- Bill mixed John up a martini.  
Bill mixed up John a martini.  
\*Bill mixed John a martini up.
- He grew up a Republican.  
\*He grew a Republican up.

The last example in (45) is also evidence for the feature PRED on predicate attribute NP's, since a PRT does not permute around these attributes.

I have concentrated in (45) on examples in which an indirect object

occurs, since such sentences are important evidence that PRT movement does not place the particle in a PP position after the direct object NP.

Rather, it moves PRT to a position after the first post-verbal NP, in non-structure-preserving fashion. If the phrase structure rules also generated a PRT node in this position, we would expect sentences with PRT's in both positions as in (46).

- (46)       \*John paid off his clerk back.  
               \*They have dammed off the river up.  
               \*They dished up the ice cream out.  
               \*He knocked in the door down.

Particle movement is therefore a non-structure-preserving rule, but it does satisfy the conditions for a permissible minor movement rule. It permutes a node PRT around a following NP (i.e., around a single constituent). Furthermore, PRT and this NP are mutually in construction.

V.2.4    Article Movement    Consider now the examples in (47).

- (47)       Mary wouldn't associate with a girl less fortunate than her.  
               Mary wouldn't associate with a less fortunate girl.  
               Is a very young kitten able to go outside?  
               That is a most depressing movie.

The indefinite article (a(n)), like other instances of NUM (numerals), precedes pre-nominal adjective phrases such as most depressing, less fortunate, very young, etc. However, if that adjective phrase is introduced by too, as, or how, this is not the case.

- (48)       \*A how young kitten is able to go outside?  
               How young a kitten is able to go outside?  
               \*John is an as nice boy as you will find.  
               John is as nice a boy as you will find.  
               \*This is a too depressing movie to see a second time.  
               This is too depressing a movie to see a second time.

This permutation of NUM (= a(n) only) and AP (= AP's introduced by as, how, and too only) can be formulated as a permitted minor movement rule, since NUM and AP are sisters, and hence mutually in construction when the rule applies. For the moment I leave open the question of whether NUM moves around AP or vice-versa; the resolution of this question will follow from restrictions on what nodes can play the roles of B and C in minor movement rules, which I will try to impose in section V.2.7.

V.2.5 Verb-Clitic Inversion in Spanish In the discussion of clitic placement (section V.1.4), it was noted that the sequence of verbal clitics (CL) in Spanish could, in embedded infinitives and participles, appear after as well as before the main verb, subject to the same ordering constraints according to grammatical person. This can be stated as a permutation of the constituents V and CL in the presence of non-finite verb endings. Since V and CL are sisters, according to the analysis given in section V.1.4, they are also mutually in construction, and hence a minor movement rule which permutes them does not violate the structure-preserving constraint.

V.2.6 Quantifier Postposition Dougherty (1968) has formulated a rule by which the three determiners all, both, and each can sometimes appear between the subject NP and the modal M. The source of these determiners in this position is an underlying subject of the form DET-of-NP. By this rule, quantifier postposition, the B. sentences in (49) are derived from the A. sentences.

- (49) A. All of us can speak Russian.  
 B. We all can speak Russian.  
 C. \*All of us each can speak Russian.

- (49) (cont.) A. Each of the boys were playing in both the parks.  
 B. The boys each were playing in both the parks.  
 C. \*Each of the boys both were playing in the parks.

It should be recalled that the auxiliaries have and be are in the M position when they are not preceded by other auxiliaries, due to the AUX movement rule.

It may be that the same rule which relates sentences in (49) also relates the grammatical pairs in (50).

- (50) John gave all of them some new clothes.  
 John gave them all some new clothes.  
 ?John gave the boys all some new clothes.
- We have been dealing with both of them.  
 We have been dealing with them both.  
 \*We have been dealing with the problems both.

I will assign a somewhat different underlying structure to NP's like all of us and each of the boys than Dougherty does:

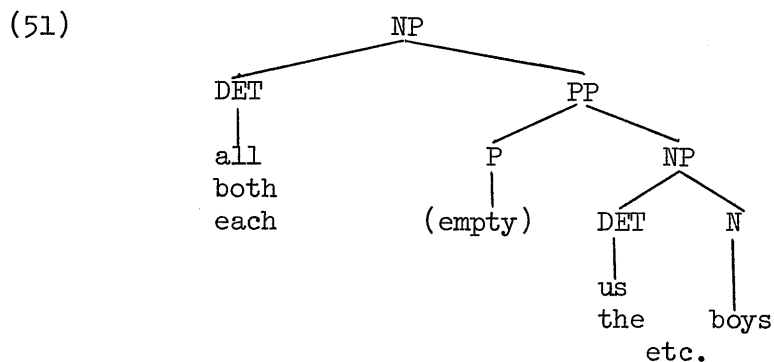

The reasons for choosing a structure like (51) are the following. In section IV.4 I argued that it was desirable to reduce the number of exceptions to the general statement "NP's exhibit subject pronouns in English if and only if they are immediately dominated by S." The object pronouns in (51) are explained by the intervening PP node between the pronoun NP and the highest S. Also, given a structure like (51), of can be inserted

automatically by the same rule that inserts of in "the destruction of the city," "the length of the table," "the sleep of the king," "that hat of John's," etc. (Any empty P with an NP object under a PP immediately dominated by NP has an of inserted in it near surface structure.)

According to the NP expansion rule in section II.6, DET can be expanded only as a single morpheme (that, every, any, all, etc.) or as an NP. According to this view, the only way a given noun can be modified by two determiners (each--the, any--John's, etc.) is if an embedded PP with an empty P provides two DET nodes, as in (51). (Recall the personal pronouns like us are DET's.)\*

Given an underlying structure like (51) for NP's like all of us and each of the boys, the quantifier postposition transformation must be restated roughly as follows:

$$(52) \quad \left[ \begin{array}{c} \text{NP} \\ \text{DET} - \text{NP} \end{array} \right] - e \Rightarrow \emptyset - 2 - 1, \text{ where DET} = \begin{array}{c} \text{all, both,} \\ \text{each} \end{array}$$

This is a minor movement rule in which B is DET and in which C is NP; C is in construction with B, so the requirement that B and C be mutually in construction is fulfilled.

The elements moved by (52) can also follow the modal auxiliary:

---

\* One might at first think that all the boys and both my friends are exceptions to this. But there are many instances of DET which all and both cannot precede: \*all us, \*both you, \*both which, \*all any Midwestern state (cf. all of any Midwestern state), \*all some classes (cf. all of some classes), \*all whom, etc. It would appear that of can be deleted after it is inserted after all and both, under certain circumstances.

An underlying structure like (51) for NP's means that the statement of selection restrictions for such NP's is not always in terms of the (highest) head noun. I will not attempt any exact solution to this problem here, although it is clear that the empty P and the lack of an independent head N in (51) figure crucially in determining what elements are subject to selection restrictions.

- (53) We can all speak Russian.  
 \*All of us can each speak Russian.

The boys were both playing in the parks.  
 \*Both the boys were each playing in the parks.

This fact means that we have to introduce the equivalent of another minor movement rule which interchanges the elements transformed by (52) and M. Whether this further inversion should be directly incorporated into (52), with a corresponding extension of the notion of possible minor movement rule, I will not try to answer here. If it is not so incorporated, a separate minor movement rule (but no extension of the notion "minor movement rule") is needed to account for (53).

In the worst case, from the point of view of enriching the class of possible non-structure-preserving transformations, quantifier postposition would be rewritten as (54):

- (54)  $[_{NP} \text{ DET} - \text{ NP}] + (\text{M}) - e \Rightarrow \emptyset - 2 - 1$ , where DET = both,  
all, each

Notice that this is essentially a movement of B over C-(D), where C-(D) is interpreted to mean that B can move over C alone even if D is present. Even given the necessity of (54), we could still exclude minor movements of a node B over C-D or over C-(D), where the latter means B must move over D if D is present. (Note that DET and M in (54) are mutually in construction.)

Another possible way to account for the sentences of (53) might lie in determining the derived structure assigned by (52). It may be that the quantifiers are attached to the sentence adverbial (AP) node which may precede M, and undergo subsequent (structure-preserving) movements as part of that constituent.

In any case, the fact that the quantifiers all, both, and each can occur after the modal M remains a problem for a structure-preserving grammar of English, but not one which seems insurmountable.

V.2.7 Further Restrictions on Minor Movement Rules A list of the various minor movement rules which I have proposed is given in (55).

It should be recalled that these are the only permissible movement rules in embedded sentences which are not structure-preserving, according to the final statement of the structure-preserving constraint. Certain arbitrary decisions are made in (55) as to which node is moved. These have, as far as I can tell, no empirical consequences.

| (55) | Name of Rule                            | Node Moved: B | Node Moved Over: C |
|------|-----------------------------------------|---------------|--------------------|
|      | (?)Dative Movement                      | NP            | NP                 |
|      | (?)Adjective-over-Noun                  | AP (or VP)    | N                  |
|      | DEG Postposing                          | DEG           | A                  |
|      | DET Incorporation                       | DET           | P                  |
|      | Particle Movement                       | PRT           | NP                 |
|      | Article Movement                        | NUM           | AP                 |
|      | Verb-Clitic Inversion (Spanish)         | CL            | V                  |
|      | Quantifier Postposition                 | DET           | NP                 |
|      | Quantifier Postposition,<br>second step | DET           | M                  |

We can divide the nodes in the phrase structure rules into three categories: those that are never pre-terminals and under which unlimited recursion seems possible in surface structure, the phrase nodes; the heads of phrase nodes, the lexical category nodes (N, A, V, P, M); and the other nodes, the function category nodes (DEG, DET, PRT, TENSE, CL, NEG, COMP, RT, etc.). It is clear from (55) that we should, on the basis of English, tentatively exclude lexical category nodes from being B (moving) nodes and function category nodes from being C (moved over) nodes in minor movement rules. We can also exclude the nodes PP and S from being either B or C



nodes in minor movement rules.

Thus, the class of minor movement rules can be delimited as follows (subject to the remarks in the preceding section about the second stage of quantifier postposition): The only non-structure-preserving rules which can apply in embedded sentences are movements of a node B over a single node C, where (i) B and C are mutually in construction, (ii) B is not a lexical node, and (iii) C is not a function category node. Furthermore, neither B or C are PP or S. If dative movement and adjective-over-noun movement are structure-preserving, we can exclude phrase nodes from being moved by minor movement rules entirely.

## BIBLIOGRAPHY

- Akmajian, A., 1970, "On Deriving Cleft Sentences from Pseudo-Cleft Sentences," Linguistic Inquiry, 1, 149-168.
- Bach, E., 1967, "Have and be in English Syntax," Language, 43, 462-485.
- Bach, E., and S. Peters, 1968, English Pseudo-Cleft Sentences, unpublished paper, University of Texas.
- Bierwisch, M., 1963, "Grammatik des deutschen Verbs," Studia Grammatica II, Akademie Verlag, Berlin.
- Bierwisch, M., and K.E. Heidolph, (forthcoming), Recent Advances in Linguistics, Mouton, The Hague.
- Chomsky, N., 1957, Syntactic Structures, Mouton, The Hague.
- Chomsky, N., 1961, "On the Notion 'Rule of Grammar,'" in Fodor and Katz (1964), 119-136.
- Chomsky, N., 1965, Aspects of the Theory of Syntax, Massachusetts Institute of Technology Press, Cambridge, Mass.
- Chomsky, N., 1970, "Remarks on Nominalization," in R. Jacobs and P. Rosenbaum, Readings in Transformational Grammar, Blaisdell, Waltham, Mass.
- Chomsky, N., (forthcoming), "Deep Structure, Surface Structure, and Semantic Interpretation," in R. Jakobson and S. Kawamoto, Studies in General and Oriental Linguistics: Commemorative Volume for Dr. Shiro Hattori, TEC Corporation, Tokyo.
- Dougherty, R.C., 1968, A Transformational Grammar of Coordinate Conjoined Structures, unpublished Doctoral dissertation, Massachusetts Institute of Technology.
- Fillmore, C.J., 1965, Indirect Object Constructions in English and the Ordering of Transformations, Mouton, The Hague.
- Fillmore, C.J., 1968, "The Case for Case," in E. Bach and R.T. Harms, Universals in Linguistic Theory, Holt, Rinehart, and Winston, New York, 1-88.
- Fodor, J.A., and J.J. Katz, 1964, The Structure of Language: Readings in the Philosophy of Language, Prentice-Hall, Englewood Cliffs, N.J.
- Fraser, B., 1968, The Verb-Particle Construction of English, Massachusetts Institute of Technology Press, Cambridge, Mass.

- Geis, M., 1970, Adverbial Subordinate Clauses in English, unpublished Doctoral dissertation, Massachusetts Institute of Technology.
- Gleitman, L.R., 1965, "Coordinating Conjunctions in English," in Reibel and Schane (1969), 80-112.
- Jackendoff, R.S., 1968, "Possessives in English," Studies in Transformational Grammar and Related Topics, Brandeis University, Waltham, Mass., 25-51.
- Jackendoff, R.S., 1969, Some Rules of Semantic Interpretation for English, unpublished Doctoral dissertation, Massachusetts Institute of Technology.
- Katz, J.J., and P.M. Postal, 1964, An Integrated Theory of Linguistic Descriptions, Massachusetts Institute of Technology Press, Cambridge, Mass.
- Kayne, R.S., 1969, The Transformational Cycle in French Syntax, unpublished Doctoral dissertation, Massachusetts Institute of Technology.
- Kiparsky, P., and C. Kiparsky, 1968, "Fact," in Bierwisch and Heidolph (forthcoming).
- Klima, E.S., 1964, "Negation in English," in Fodor and Katz (1964), 246-323.
- Kuroda, S.-Y., 1968, "English Relativization and Certain Related Problems," in Reibel and Schane (1969), 264-287.
- Lakoff, G., 1966, "A Note on Negation," Report NSF-16, Harvard University Computation Laboratory, Cambridge, Mass.
- Lakoff, G., and S. Peters, 1966, "Phrasal Conjunction and Symmetric Predicates," in Reibel and Schane (1969), 113-142.
- Lakoff, G., and J.R. Ross, 1966, "A Criterion for Verb Phrase Constituency," Report NSF-17, Harvard University Computation Laboratory, Cambridge, Mass.
- Lee, P.G., 1967, "The English Preposition WITH," Working Papers in Linguistics, I, Ohio State University, Columbus, Ohio, 30-79.
- Newmeyer, F.J., 1969, "English Aspectual Verbs," Studies in Linguistics and Language Learning, VI, University of Washington, Seattle, Washington.
- Perlmutter, D.M., 1968, Deep and Surface Structure Constraints in Syntax, unpublished Doctoral dissertation, Massachusetts Institute of Technology.

- Perlmutter, D.M., 1968b, "On the Article in English," in Bierwisch and Heidolph (forthcoming).
- Postal, P.M., 1966, "On So-called 'Pronouns' in English," in Reibel and Schane (1969), 201-224.
- Rardin, R., 1968, Sentence Raising and Sentence Shift, unpublished paper, Massachusetts Institute of Technology.
- Reibel, D.A., and S.A. Schane, 1969, Modern Studies in English: Readings in Transformational Grammar, Prentice-Hall, Englewood Cliffs, N.J.
- Rosenbaum, P.S., 1967, The Grammar of English Predicate Complement Constructions, Massachusetts Institute of Technology Press, Cambridge, Mass.
- Ross, J.R., 1967, Constraints on Variables in Syntax, unpublished Doctoral dissertation, Massachusetts Institute of Technology.
- Ross, J.R., 1967b, "Gapping and the Order of Constituents," in Bierwisch and Heidolph (forthcoming).
- Ross, J.R., (forthcoming), Act, unpublished paper, Massachusetts Institute of Technology.
- Smith, C.S., 1961, "A Class of Complex Modifiers in English," Language, 37, 342-365.
- Smith, C.S., 1964, "Determiners and Relative Clauses in a Generative Grammar of English," in Reibel and Schane (1969), 247-263.
- Zwicky, A., 1970, "Auxiliary Reduction in English," Linguistic Inquiry, 1, 321-336.

#### BIOGRAPHICAL NOTE

The author was born on April 7, 1940, in Minot, North Dakota, to Joseph F. and Margaret Emonds. He received a bachelor's degree from Loras College in 1962 and a master's degree in mathematics from the University of Kansas in 1964. While at the University of Kansas he was elected to Phi Beta Kappa and Sigma Xi. In 1964-65 he taught mathematics at the Naval Academy in Annapolis, Md. In the fall of 1965 he entered the doctoral program in linguistics at M.I.T., spending, however, one year (1968-69) as a fellow at the Center for Advanced Study in Urbana, Illinois. At present he is teaching at the Centre Experimental de Vincennes in Paris, France. Chapter III of this thesis is to be published, in slightly altered form, in the forthcoming volume Goals of Linguistic Theory, edited by Stanley Peters.