

ENERGY LABORATORY
LIBRARY

MONOGRAPHS

on

ALTERNATE ENERGY AND ELECTRIC POWER SOURCES

Assembled and Prepared

for

PUBLIC SERVICE COMPANY OF NEW HAMPSHIRE

ENERGY LABORATORY INFORMATION CENTER

William J. Jones
James W. Meyer

1 June 1975

Energy Laboratory
Massachusetts Institute of Technology
Cambridge, Massachusetts 02139

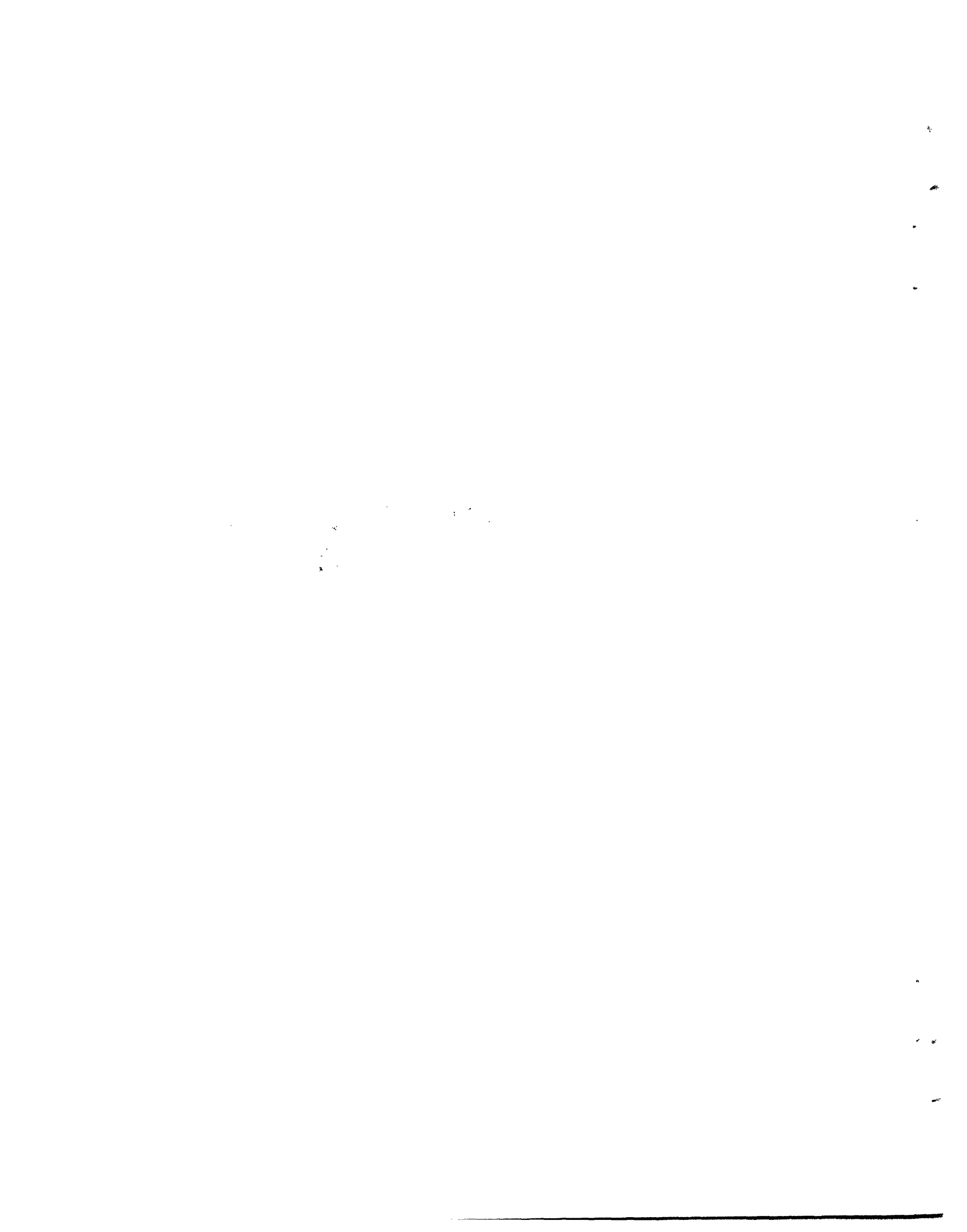

TABLE OF CONTENTS

Executive Summary

Monograph No. 1 - Solar Energy

Monograph No. 2 - Wind Energy

Monograph No. 3 - Ocean Thermal Energy Conversion

Monograph No. 4 - Geothermal Energy

Monograph No. 5 - Hydroelectric Power

Monograph No. 6 - Oil Shale

Monograph No. 7 - Solid Waste for the Generation
of Electric Power

Monograph No. 8 - Energy from Forests, Plantations
and Other Biomass

Monograph No. 9 - Hydrogen Fuel

Monograph No. 10 - Gas Turbines

Monograph No. 11 - Fuel Cell Generation of Electric
Power

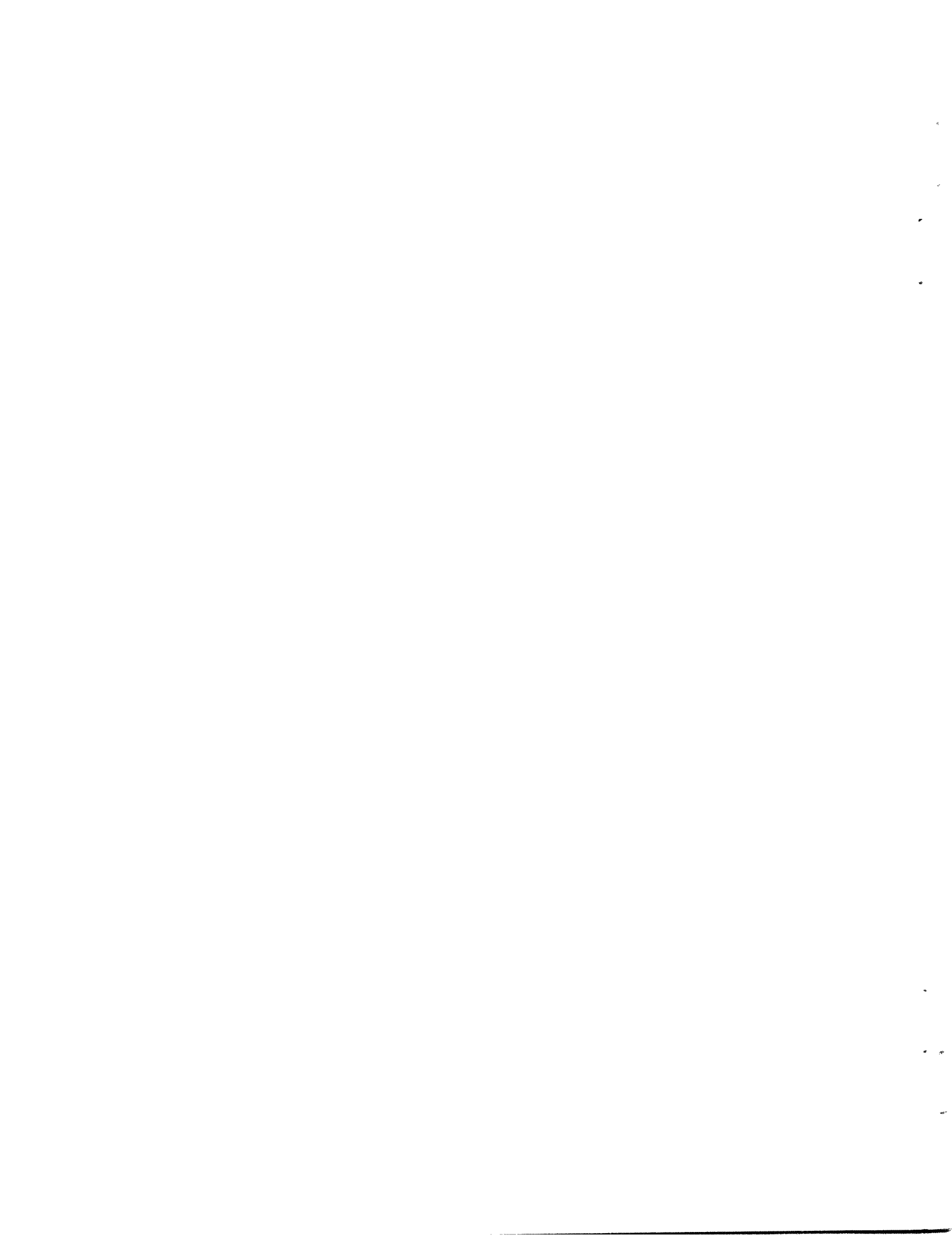

Monographs

on

ALTERNATE ENERGY AND ELECTRIC POWER SOURCES

Executive Summary

Eleven monographs have been prepared as background material supportive of general conclusions that might be drawn regarding the efficacy of alternate energy and electric power sources in meeting the projected needs of New England in general and New Hampshire in particular. In preparing the working papers, every effort was made to avoid a position of advocacy, but to present the facts revealing the current situation and some prospects for the future in each case. From these facts, we believe logical conclusions can be drawn.

We took the Public Service Company of New Hampshire's projected need of a 2300 megawatt base-load capacity as given. We discuss alternate sources in this context.

The subjects of the monographs fall into three categories:

1. Direct Energy Sources; 2. Alternative Fuels; and 3. Advanced Energy Conversion Technologies. Direct energy sources are those which need not involve a fuel intermediary in their conversion to useful energy or power forms (heat or electric power). Alternative fuels are those not now widely employed for the generation of electric power. Advanced conversion technologies are those which promise increased efficiency in the conversion of hydrocarbon fuels into electric power.

We believe the monographs support the following general conclusions:

- o While the basic technology of these alternatives may offer no problems, the general lack of full-scale engineering prototypes at the present time does not support confidence that reliable operational units are less than 10 to 15 years away.
- o Most of the alternatives studied are more appropriate as supplemental energy sources rather than as base load serving facilities.
- o Because of their geographically distributed nature, some of these alternatives would be better consumer implemented than producer implemented.
- o Alternative fuels would be better used to lessen our need for high-grade fossil fuels in electric power generating systems, i.e. use for meeting peak load demand.

Specific comments:

- o Solar Energy: A reasonable supplementary source for space heating and domestic hot water. Storage is a problem. Need mass production facilities, distribution, maintenance, and service organizations for new construction and retrofit equipment.
- o Wind Energy: Like the sun, a reasonable supplementary source. One-time experience with megawatt electric power production. Current demonstration research at the 100 kilowatt level. Storage and power conditioning equipment are problems.

- o Ocean Thermal Gradient: More appropriate to the tropic or subtropic zones. Biofouling of massive heat exchangers is a major problem. Large quantities of water, with a temperature difference in the order of 22°C (40°F), would have to be introduced into two different sectors (depths and surface). Adverse environmental effects, if any, are unknown. If the problems of utilizing small temperature differences for generation of power are solved, the resulting system would be more appropriately applied as a bottoming cycle for large New England power plants having access to cold ocean water to serve as a heat sink.
- o Geothermal Energy: No readily accessible New England sites. Development of available sources elsewhere could lessen pressure on fuels and other types of energy generation that New England and the rest of the U.S. uses.
- o Hydroelectric Power: Because available water is generally fully utilized, expansion of existing capacity can only be done at the expense of operating time. In the "falling water" class only one large new site available to New England, Dickey-Lincoln. Passamoquoddy, Maine, is a potential in the "tidal" class. Earlier studies did not reveal economical production. Today, environmental impact considerations could be decisive.
- o Oil Shale: Just beginning to face problems of large-scale production of oil from shale. Major problems are connected with disposal of shale residue and competition for available water in arid shale regions. In some areas the net energy of the resultant energy obtained minus the amount consumed in order to extract the oil is negative.

- o Solid Waste: An attractive supplemental fuel for fossil fuel power plants. Can be processed to gas or liquid fuel or burned shredded when separated. Large urban centers offer desirably concentrated source. There is a growing body of practical experience to draw on.
- o Biomass: Another useful supplement. Collection and concentration present problems. A rural rather than an urban operation. Consumer oriented systems may provide farm fuel supplements.
- o Hydrogen Fuel: Attractive future fuel. Now need cheap electric power for economical electrolytic production of hydrogen. Hydrogen embrittles materials used in pipe lines and storage tanks. New methods of producing hydrogen need development. Might be an attractive supplementary fuel for distributed power generation with fuel cell power plants. Hydrogen important in the production of other alternative fuels, e.g. methanol or methyl fuel.
- o Gas Turbines: Offer potential for improved thermal efficiencies when combined with a steam cycle. Reduces waste heat per unit of energy produced. Units in production now are relatively small, less than a hundred megawatts. Need clean fuels. NO_x major pollution problem.
- o Fuel Cell: Twenty six megawatt unit for distributed power generation nearing production. Competes for scarce clean fuels. Most efficient in a peaking application. Hydrogen is the best fuel for fuel cells, but production and distribution systems for hydrogen must be set up to serve the distributed electric power generating plants.

Monograph No. 1
MIT Energy Laboratory
SOLAR ENERGY

PRECIS

New Hampshire has an average annual solar power flux of 135 watts/ M^2 with a daily mean of 60 watts/ M^2 in December and 245 watts/ M^2 in July. Day to day variations between peak and average are 1.5 to 1 in the winter and 2 to 1 in the summer. The dispersed nature and variability of this energy are serious challenges to its ability to provide large amounts of reliable electric power service. Large collectors and sizeable storage are essential.

There are two methods for converting solar energy to electrical power. Photovoltaic Conversion produces power directly from silicon or Cd sulphide solar cells. Silicon panels currently cost \$40,000/ M^2 or about \$300/watt. Total photovoltaic conversion equipment, to produce 60 cycle 120 volt ac in New Hampshire, would currently cost about \$1200/watt of capacity. Projections indicate that with today's technology this could be reduced to about \$10/watt in a few years and perhaps ultimately below \$1/watt.

Solar/Thermal/Electric conversion systems heat water or other two phase fluids such as ammonia or Freon to the gaseous state to drive turbine-generators. To achieve high temperatures for thermal efficiency, concentrators for the incident solar radiation are necessary. Estimates of concentrators in the southwestern United States range from \$60/ M^2 to \$1800/ M^2 (in volume production). In New Hampshire, assuming the same construction cost, this would mean a cost between \$4/watt and \$12/watt.

To produce 1000 MWe (average), allowing for steam turbine efficiency and concentrator losses, would require a concentrator area, allowing for other facilities, of about $33 \times 10^6 M^2$ (10,000 acres) oriented to the south and at 45° to the vertical and a land area of about $200 \times 10^6 M^2$ (about 50,000 acres or 9 miles x 9 miles). Unsolved technical problems include deterioration of collector reflective surfaces and increasing the collector output temperature. One limitation is that clear skies, to insure parallel rays, are necessary for a concentration. Present designs are projected to operate at an efficiency of about 50% at $500^\circ C$.

To solve the energy storage problem, latent heat storage, using rocks, salt, etc., of about 1000°C , has been proposed for short-term storage and the production of hydrogen fuel for long-term storage. Hydrogen production by high pressure electrolysis at an energy efficiency of 80% to 94% appears practical. A 1000 MWe plant would reduce about 6×10^5 kg of hydrogen from 1.5 million gallons of pure water per day. The hydrogen, stored unpressurized, would require about $7 \times 10^4 \text{ M}^3$ of storage. The electrolysis/storage system is projected to cost \$100/kg of hydrogen produced per day or 60 million dollars.

A cooling tower facility would be needed for the solar/thermal system because in New Hampshire a solar plant is too large (15 KM x 15 KM) (9.3 miles x 9.3 miles) to locate near a large body of water.

A dry cooling tower facility to handle 1000 MWe has not been designed. The cost of a wet cooling tower is projected at \$60,000/MWe. The size of a natural draft hyperbolic wet tower would be approximately 125 meter (410 feet) (base) and 115M (375 feet) (height).

Solar augmented heating and cooling of individual buildings appears practical and desirable in New Hampshire.

Flat plate collectors can produce temperatures up to 50°C above ambient at an estimated cost of $\$45/\text{M}^2$ in volume production. Short-term thermal storage (≈ 1 day) using heated water or rocks is practical. An optimized system is about 200 gallons of water per square meter of collector area. Total space conditioning cost (installed) has been projected at about $\$2.00/10^6$ BTU of collected solar energy.

Systems for space conditioning using solar energy are compatible with electric heating and can be used to reduce peak demand while increasing the utilization of base load demand.

OUTLINE - SOLAR ENERGY

I. Parameters of Solar Energy

- A. Solar Conditions
- B. Solar Conversion
- C. Solar Applications

II. Solar Energy for Electric Power Generation in New Hampshire

- A. New Hampshire Solar Flux
- B. System to Produce 1000 MWe
 - 1. Solar-Voltaic
 - 2. Solar-Thermal
 - 3. Energy Storage
 - 4. Cooling Tower
- C. Solar Augmented Space Heating

III. Summary

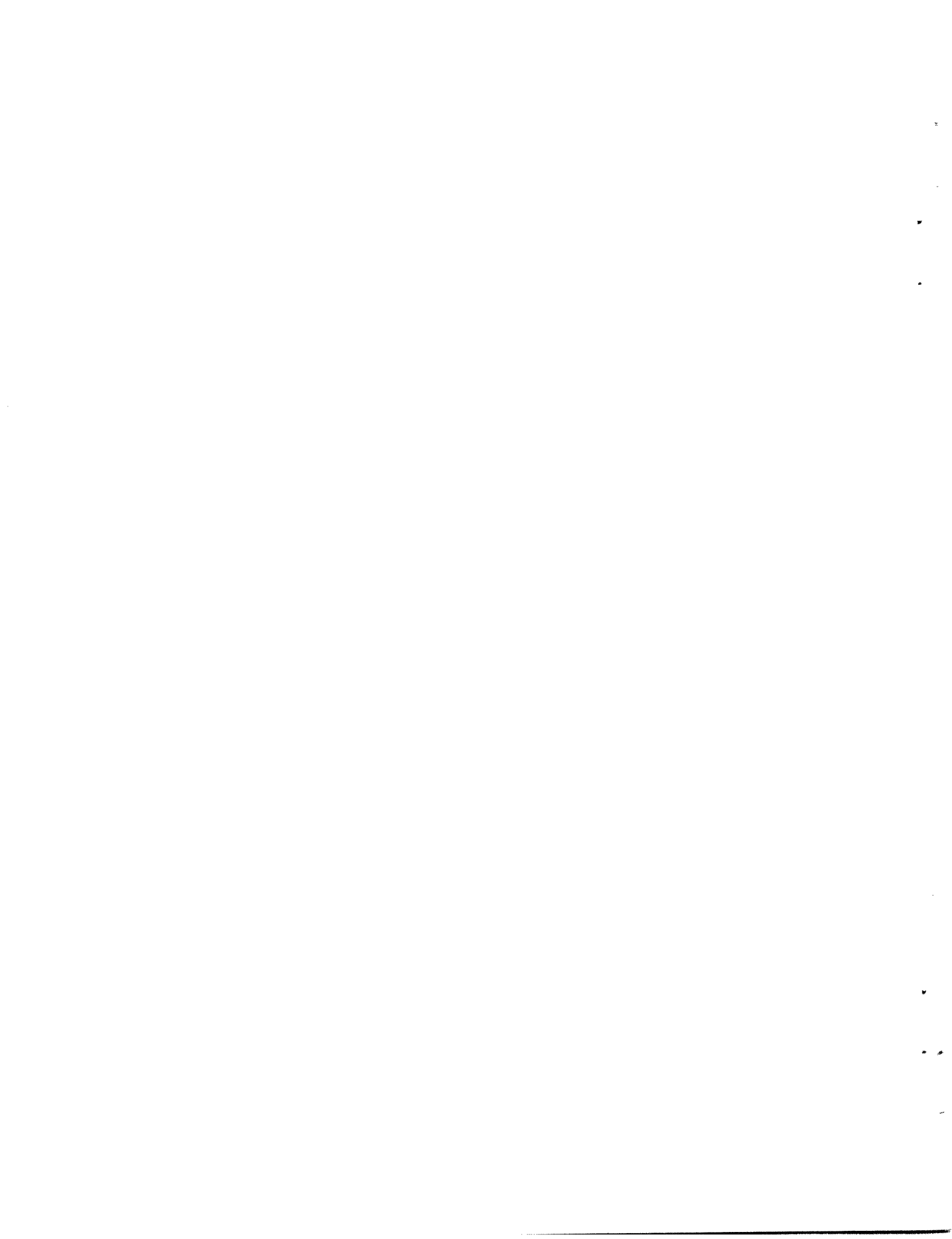

MIT ENERGY LABORATORY WORKING PAPER

SOLAR ENERGY

I. PARAMETERS OF SOLAR ENERGY

A. Solar Conditions

Outside the earth's atmosphere the sun is a steady source of energy. The solar constant, or energy received, is equivalent to 430 BTU/FT² per hour, or 1360 watts per square meter. On the surface of the earth the solar intensity is diminished by atmospheric absorption, becomes unsteady depending upon climatic conditions, and varies greatly with seasonal changes and terrestrial location. Figure 1 shows the effect of latitude on energy flux on a horizontal surface in June and December, including both clear days and average days together with the annual average value.¹

Figure 1 shows that compared to the 1360 watts/M² that is available outside the atmosphere, or the 100 watts/M² on the earth's surface which is available when the sun is directly overhead on a clear day, the average daily input on the ground is significantly less. Also the latitude of a locality is considerably less important in determining its solar-energy reception than is the local cloudiness. By tilting a receiving surface toward the equator to favor the winter sun, a large part of the seasonal variation in solar incidence can be eliminated. The effect of collector tilt at 40° latitude is indicated in Figure 2.

B. Solar Conversion

The sun represents an enormous inexhaustible source of energy which can be harnessed. However, as shown by Figure 1 and Figure 2, the solar energy at the surface of the earth is highly variable and extremely dilute; its average flux density is only about five-hundredths of that of a modern steam boiler. In most applications, solar energy must be concentrated, converted to a more useful form, and then stored for use when the sun is not available. The fuel (solar energy) is free, but the equipment associated with concentration, conversion, and storage can be expensive.

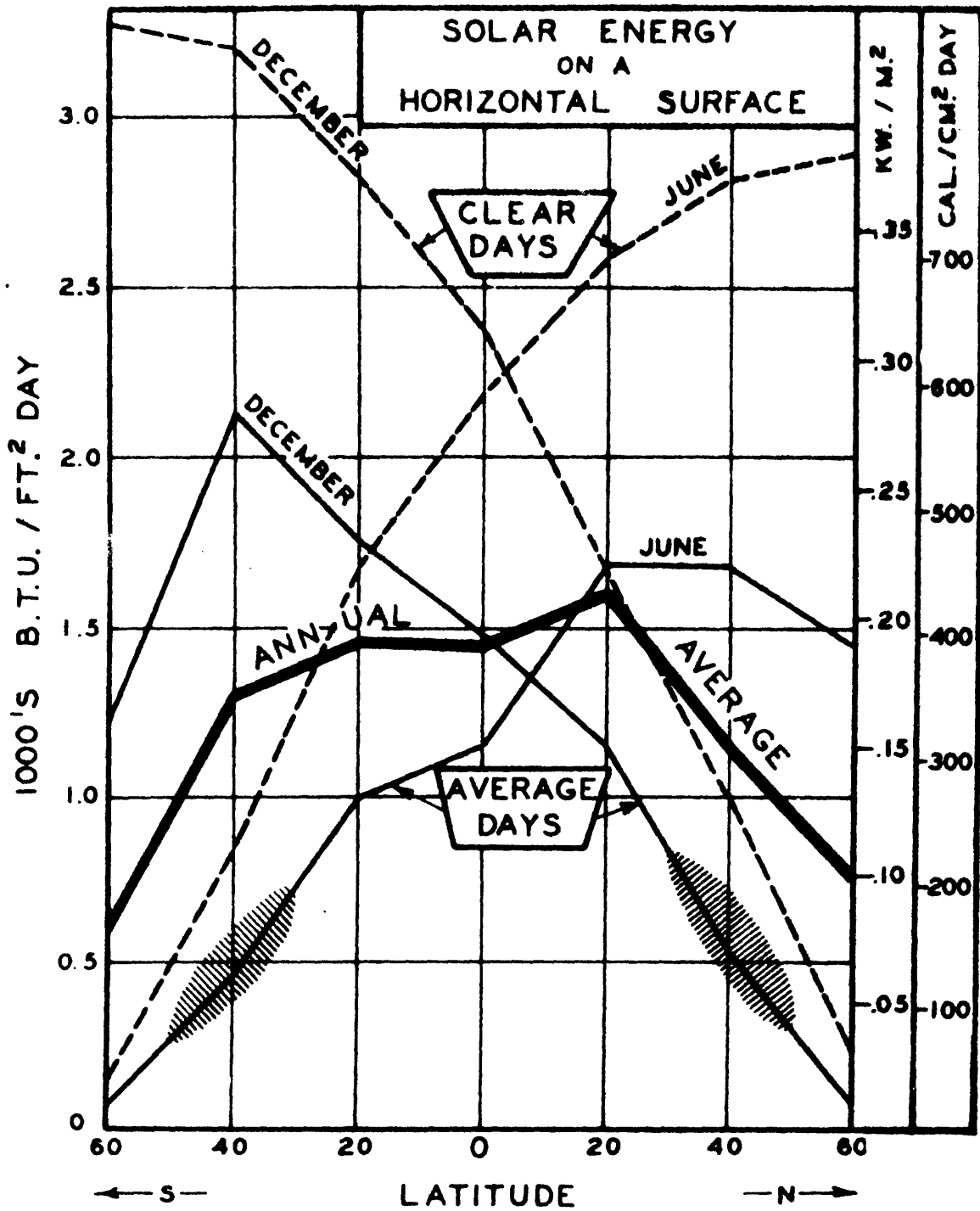

Figure 1: Solar-Flux Latitude

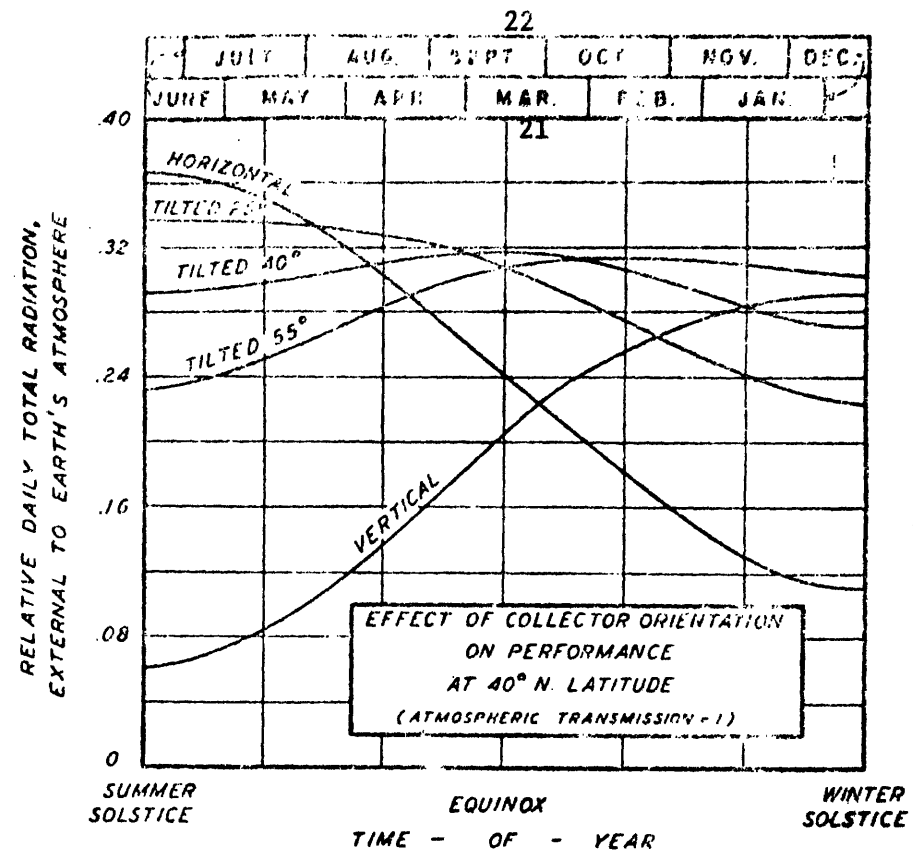

Figure 2: Effect of Collector Tilt

There are a variety of energy-conversion techniques;² solar radiation may be converted to electricity by solar cells and may be utilized in conventional heat engines (such as steam turbines). Electricity can also be generated indirectly from the sun in the form of winds or ocean thermal gradients.^{3,4} Gaseous, liquid, and solid fuels can also be produced by direct solar radiation in a number of ways; photodecomposition of water, photosynthetic growth of organic matter which can be converted to fuels by destructive distillation, fermentation, by high pressure chemical processing, or photochemical conversion processes. These renewable fuels can in turn be used in conventional energy processing plants to produce electrical energy. The type of solar energy appropriate to fulfill a need is dependent upon a complex set of socio-economic conditions, but certain invariant parameters are discernable:

- (1) The sun is a uniformly distributed source.
- (2) Although solar flux is higher in equatorial zone ($\pm 23^\circ$), it is sufficient, up to perhaps $\pm 45^\circ$ latitude, to satisfy most applications providing sufficient storage can be implemented to compensate for varying climate conditions.
- (3) The solar flux is so dilute that to produce temperatures in a working fluid greater than about 85°C above ambient requires concentration of the solar flux.
- (4) Equipment for the collection of solar energy profits little by economics of scale.
- (5) The day/night dependence and weather dependent variability of solar energy makes it necessary to include an energy storage facility in any (every) solar power system.

C. Solar Applications

There are three general ways that solar energy can be applied to augment conventional power systems:

Electric Power Generation - Directly from the sun using thermal and/or photovoltaic conversion techniques, or indirectly using wind or ocean thermal gradients.

Production of Synthetic Fuels - By photosynthesis of organic

materials or electrolysis of water to produce hydrogen.

Production of Thermal Energy for Space Heating

II. SOLAR ENERGY FOR ELECTRIC POWER GENERATION IN NEW HAMPSHIRE

A. New Hampshire Solar Input

The average solar flux falling on a horizontal surface in various locations in the U.S. are shown in Figure 3.⁶ The average solar flux can be used only when long-term storage is available (\approx 6 months). For systems with short-term storage (\approx 2 weeks), the winter values shown in Figure 4 must be used. Higher densities can be obtained by orientation of the solar collectors. Table I shows estimates of the annual and winter average flux intensities that would be available on oriented collectors in New Hampshire.

TABLE I

<u>Collector Orientation</u>	Estimate of Average Solar Energy Flux Density (Watts per Sq. Meter)* BTU/M ² -hr			
	<u>Annual Average</u>		<u>December Average</u>	
Fixed-Horizontal	(145)	500	(55)	185
Fixed-Facing South at 45° Above Horizontal	(160)	545	(130)	450
One-Axis Steerable in Elevation	(195)	665	(140)	475
Two-Axis Steerable	(270)	925	(145)	500

* Watts/M² x 3.41 = BTU/M² -hr

B. System to Produce 1000 MWe

Several studies have produced conceptual drawings that depict the large scale use of solar cells (Figure 5 and Figure 6) or solar thermal concentrators (Figure 7) to generate electrical energy from the sun. A particularly imaginative proposal is one that generates power in space,

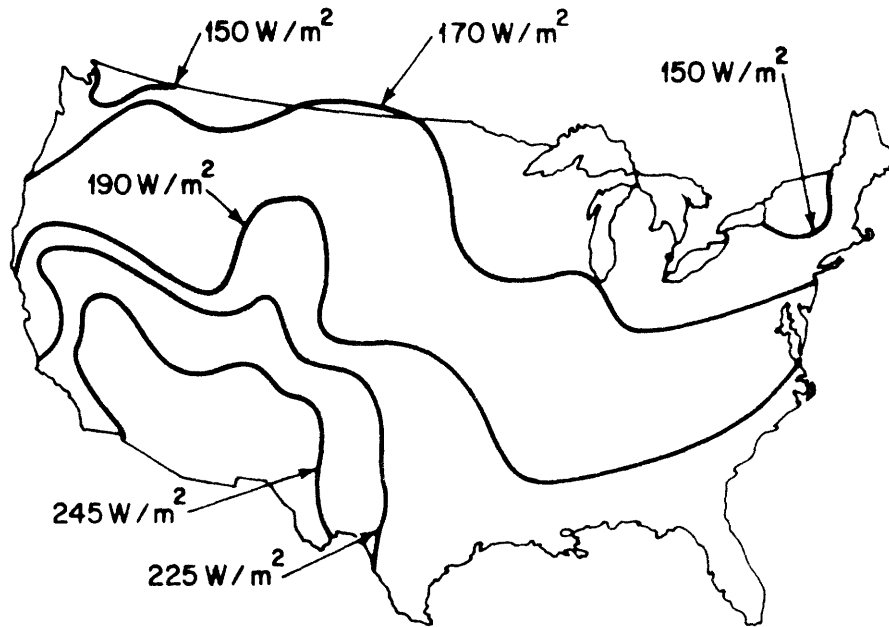

Fig. 3: Yearly Average of Solar Energy Incidence in Watts per Square Meter (Horizontal surface)

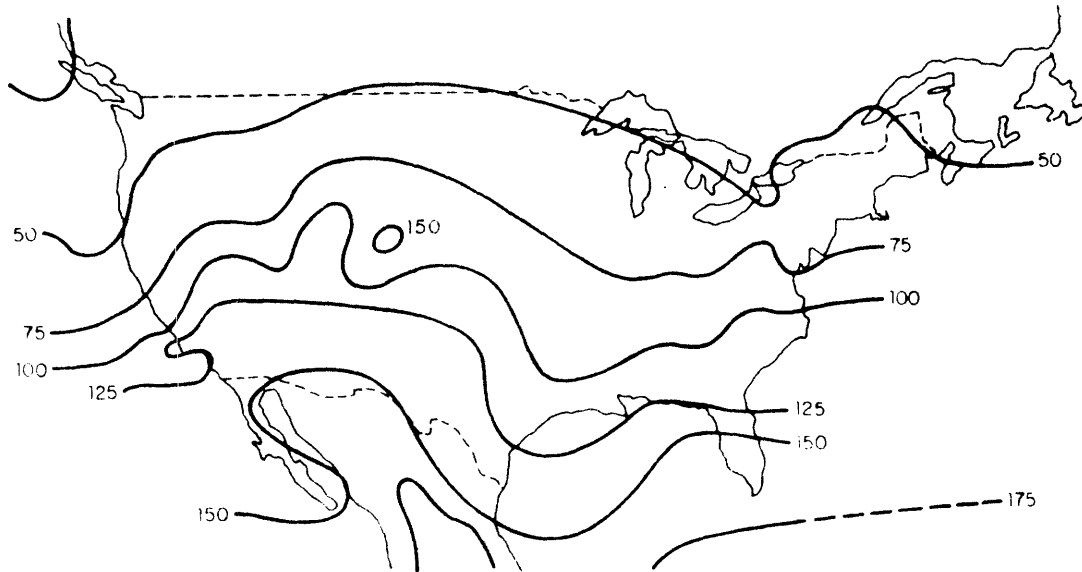

Fig. 4: December Average of Solar Energy Incidence in Watts per Square Meter (Horizontal surface)

SOLAR CELL PARK

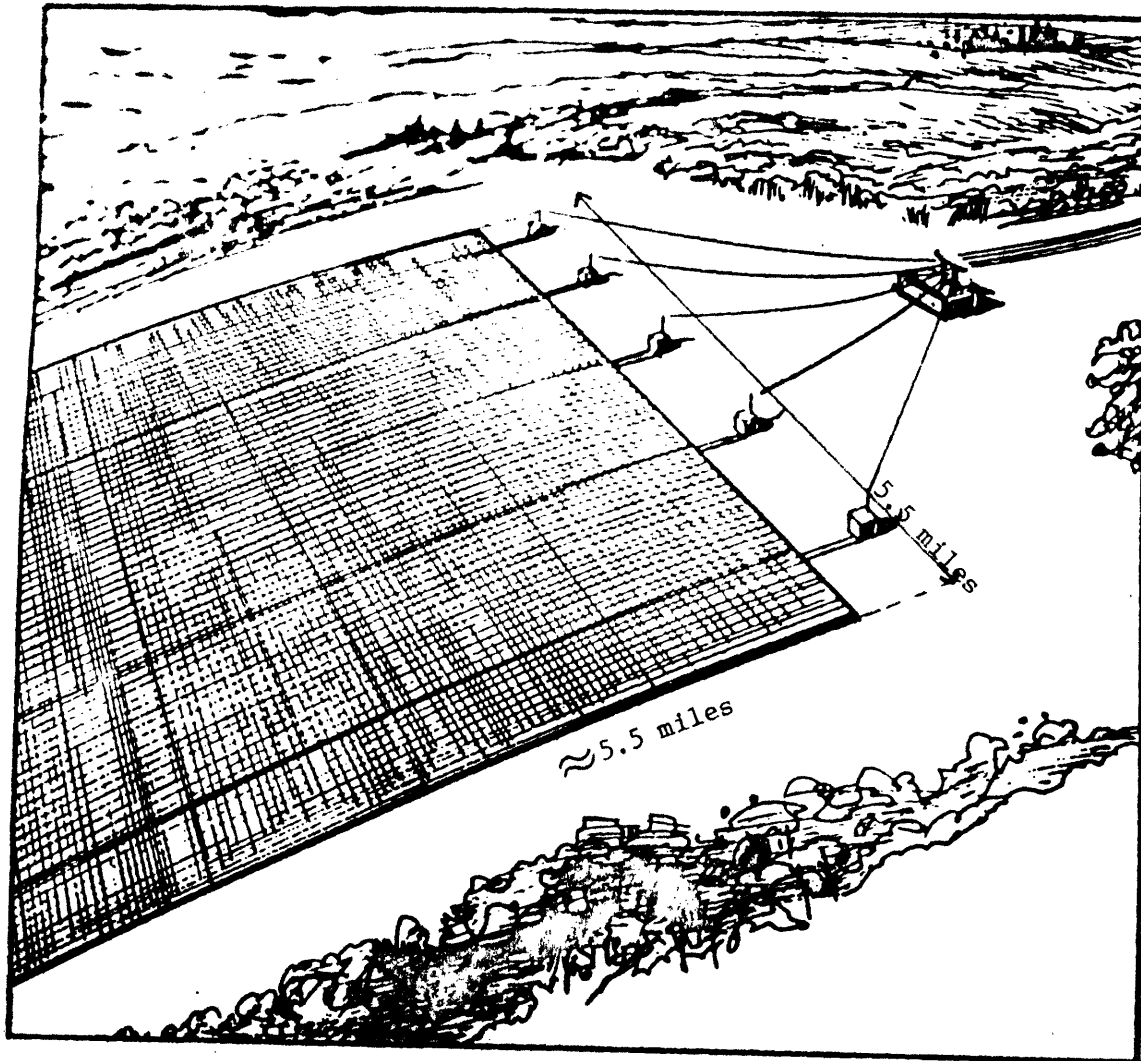

Figure 5: Power Generation with Solar Cells
1000 mWe

(Reference 14)

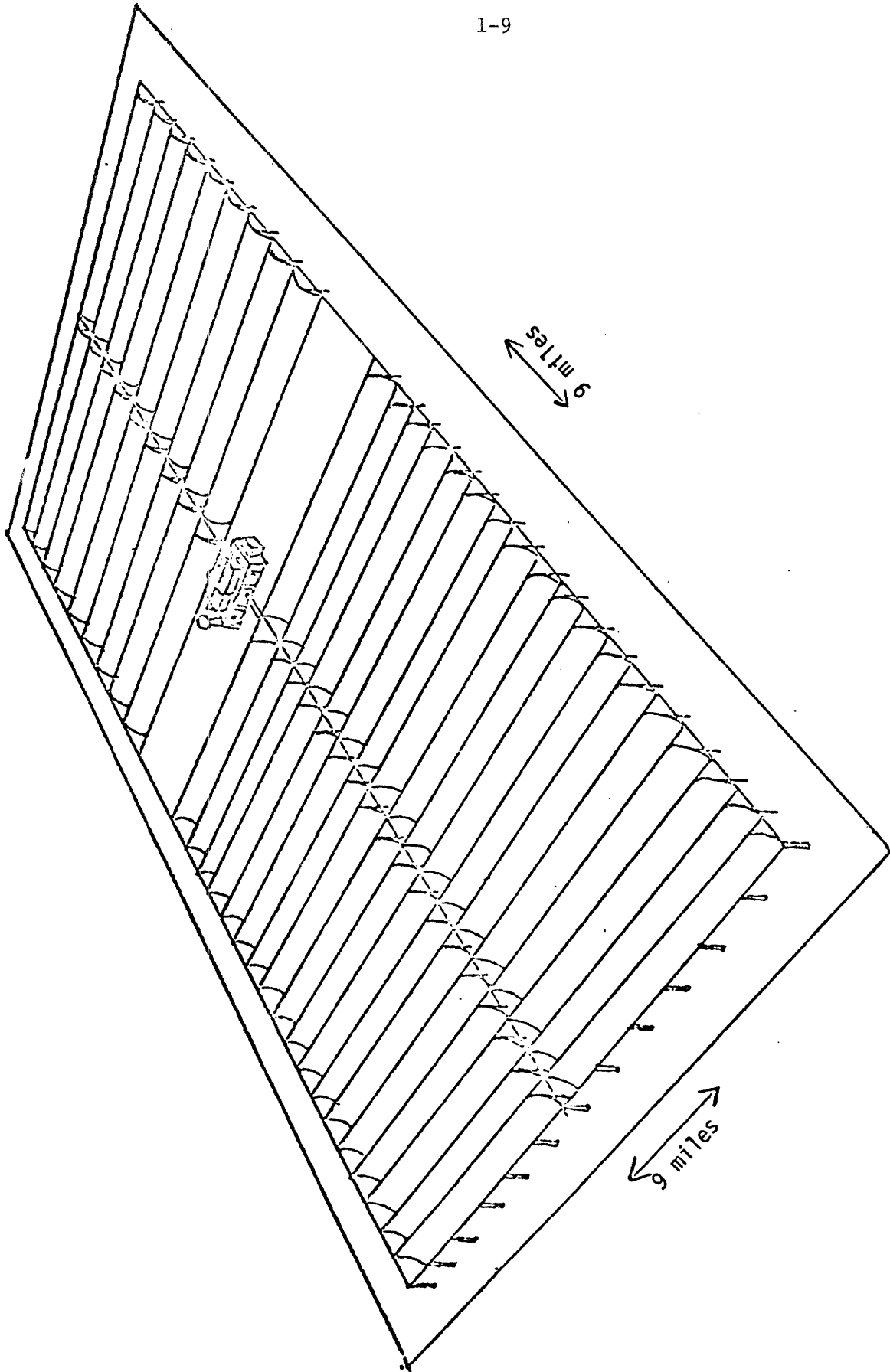

Figure 6: Solar Farm A

(Reference 14)

**CROSS SECTION DIAGRAM OF A TYPICAL COLLECTOR PANEL USING
A CYLINDRICAL REAR-SURFACED MIRROR AS THE CONCENTRATOR**

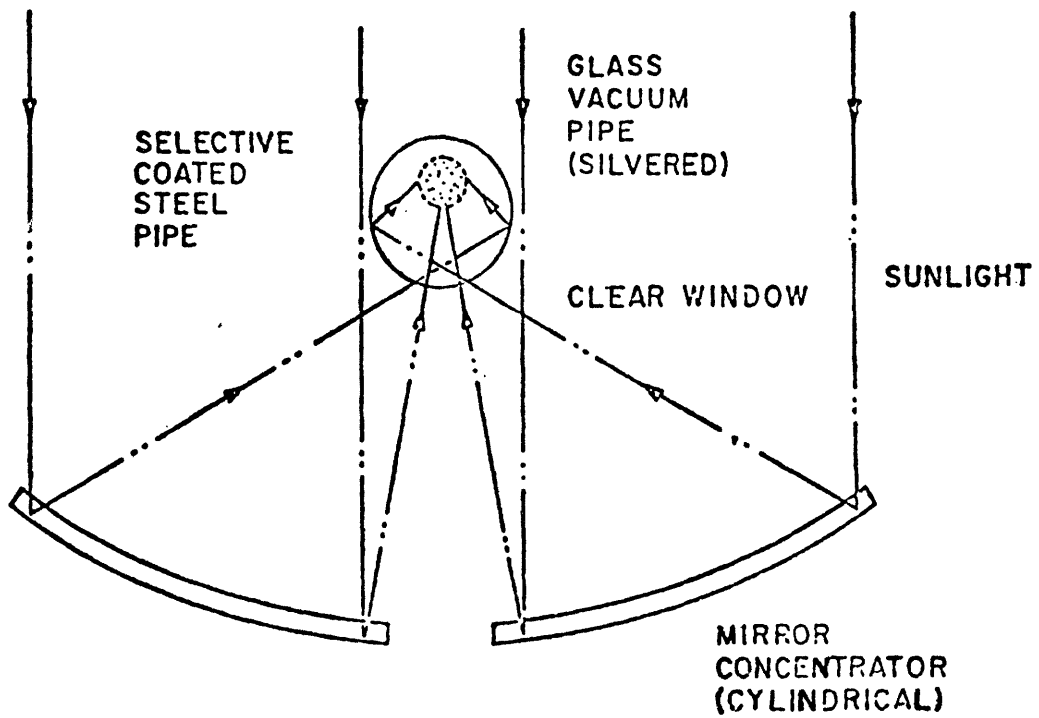

Figure 7: Typical One-Axis High-Temperature Collector

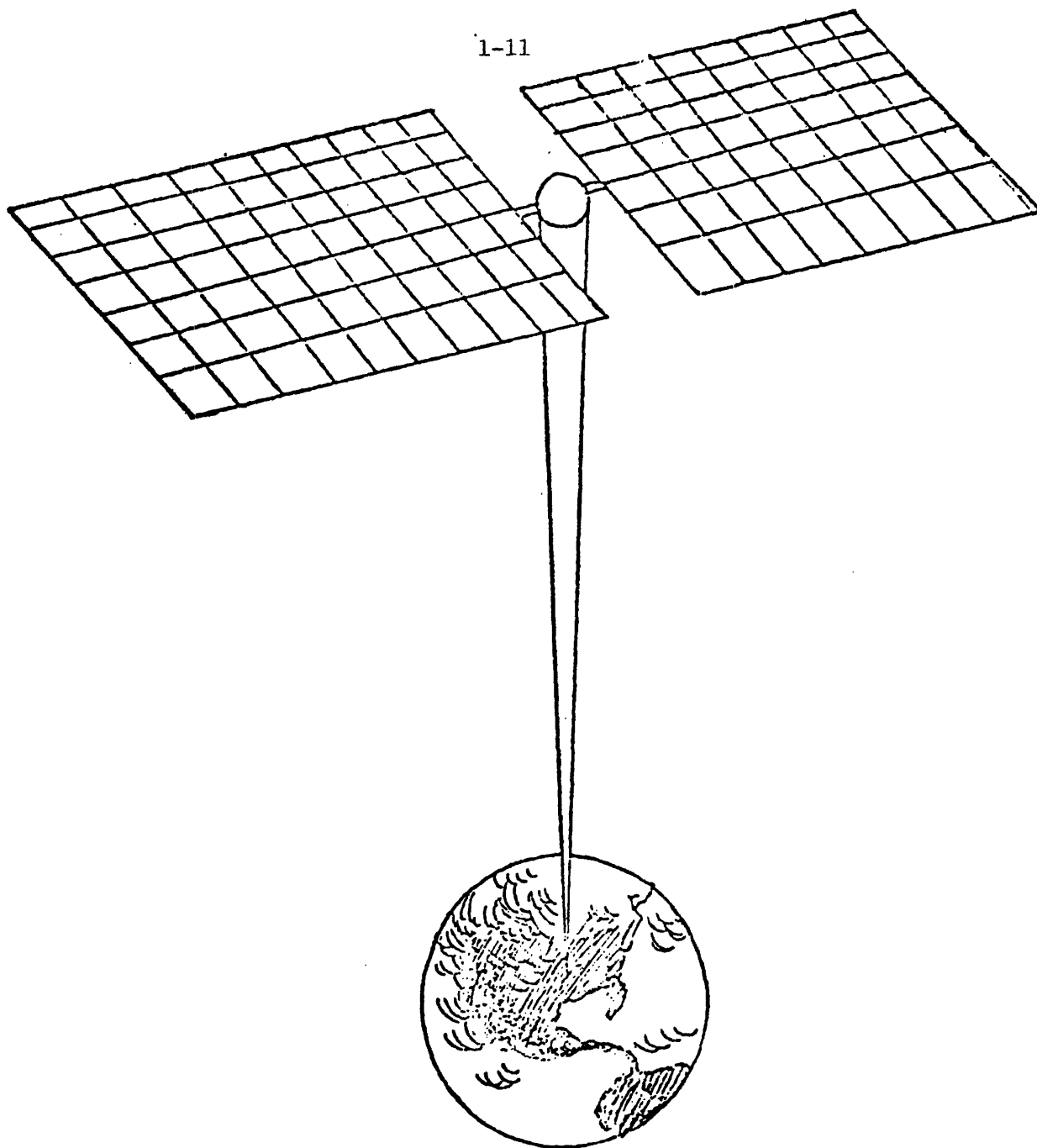

Figure 8: (Reference 7)

SOLAR COLLECTOR IN STATIONARY ORBIT has been proposed by Arthur D. Little, Inc. Located 22,300 miles above the Equator, the station would remain fixed with respect to a receiving station on the ground. A five-by-five mile panel would intercept about 8.5×10^7 kilowatts of radiant solar power. Solar cells operating at an efficiency of about 18 percent would convert this into 1.5×10^7 kilowatts of electric power, which would be converted into microwave radiation and beamed to the earth. There it would be reconverted into 10^7 net kilowatts of electric power, or enough, for example, for New York City. The receiving antenna would cover about six times the area needed for a coal-burning power plant of the same capacity and about 20 times the area needed for a nuclear plant.

where solar energy can be obtained continually, and then sends the power to earth via microwaves (Figure 8). This would eliminate the need for large capacity energy storage.⁷ Notwithstanding the long term promise of such proposals, at the present the problems are formidable.

1. Solar Photovoltaic Conversion

New Hampshire receives solar energy at an annual rate of about 155 watts/M². For a surface tilted south by 45° this value increases to about 160 watts/M². The best individual solar cells have a conversion efficiency of 12% to 15% at a room temperature of 20°C. In a panel, however, the light transmission of protective cover plates decrease with time due to UV-darkening and dirt, the ambient temperature is higher, cell matching losses occur, etc., and the conversion efficiency will drop perhaps to about 8.5% or less. A "solar farm" with 8.5% efficiency panels facing 45° south would produce about 13.5 watts/M². Accordingly, to produce 1000 MWe would require about 75 x 10⁶ M² (8.6 KM x 8.6 KM) of solar cells.

At the present time (1974) solar cells for space applications cost about \$40,000/M² (\$300/watt x 135 watts/M²). There is no real consensus as to what could be achieved if produced on a large scale for terrestrial applications but \$5/watt with silicon appears to be possible within a few years.^{1,8,9,10} With an appreciable R and D effort, using polycrystalline materials, such as copper sulfide and cadmium sulfide, perhaps \$1 to \$1.50 per watt might be obtained in a few years, with an ultimate cost as low as 40¢ to 60¢ per watt.¹⁰ Small quantities of thin film Cu₂-CdS solar cells have been produced in pilot lines with efficiencies of 4 to 6 percent.¹¹ Their fabrication processes appear amenable to mass production methods but so far yields have been low and the cells degrade.¹²

Projected cost estimates for panel structure designed to withstand the rigors of New England environment^{12,14} and to protect solar cells range from \$20 to \$40 per square meter. Using a cost of \$30/M² for the panel structure and a 300 to 1 reduction from the present cost of solar cells (i.e. \$40,000/M² to \$133/M²) we obtain a projected-lower-cost

estimate of about $\$163/\text{M}^2$ ($\$30/\text{M}^2 + 133/\text{M}^2$) photovoltaic panels. With New Hampshire's annual solar input this is $\$12,000/\text{KW}$.

2. Solar/Thermal/Electric Conversion Systems

In order to achieve high temperatures high enough to produce electricity by conventional methods, collectors that concentrate the solar flux are required. These collectors are relatively expensive because they must have low emissivity and low conduction losses.

One thermal conversion proposal^{9,15} includes the use of one-axis steerable cylindrical parabolas. The collectors, as shown in Figures 8 and 9, would be east-west oriented and cover about 50% of the land area. Vacuum insulated heat collection pipes would be used at the focal points of the collectors. The energy would be stored as thermal energy in molten salt. Conventional steam turbine generators would be used to produce electricity. Typical parameters of a 1000 MW continuous output plant have been estimated as follows:^{9,15}

Area of plant	-	40 km ²
Area of collectors	-	22 km ²
Outlet temperature of collectors	-	500° - 600°
Collection efficiency	-	≈ 60%
Thermal plant efficiency	-	≈ 40%
Overall efficiency	-	≈ 25%

The allowable construction budget for such a farm to produce power at a cost of 5.3 mills/kwh at a 25% conversion efficiency has been estimated in 1971 by Meinel⁹ at $\$60/\text{square meter}$ for a site in the southwest having 330 clear days a year. Hottel and Howard² believe Meinel estimates assume overly optimistic optical and lifetime performance for selective coating and do not adequately account for degradation in optical transmittance in glass piping due to weathering and ignores pumping power required to circulate heat transfer fluids; they find an overall conversion efficiency of about 10% more reasonable.

Cost of utilizing solar energy will be much greater in New England than in the southwest because the collector array needs to be about twice as large. Moreover, the land costs are greater and the environmental conditions differ.

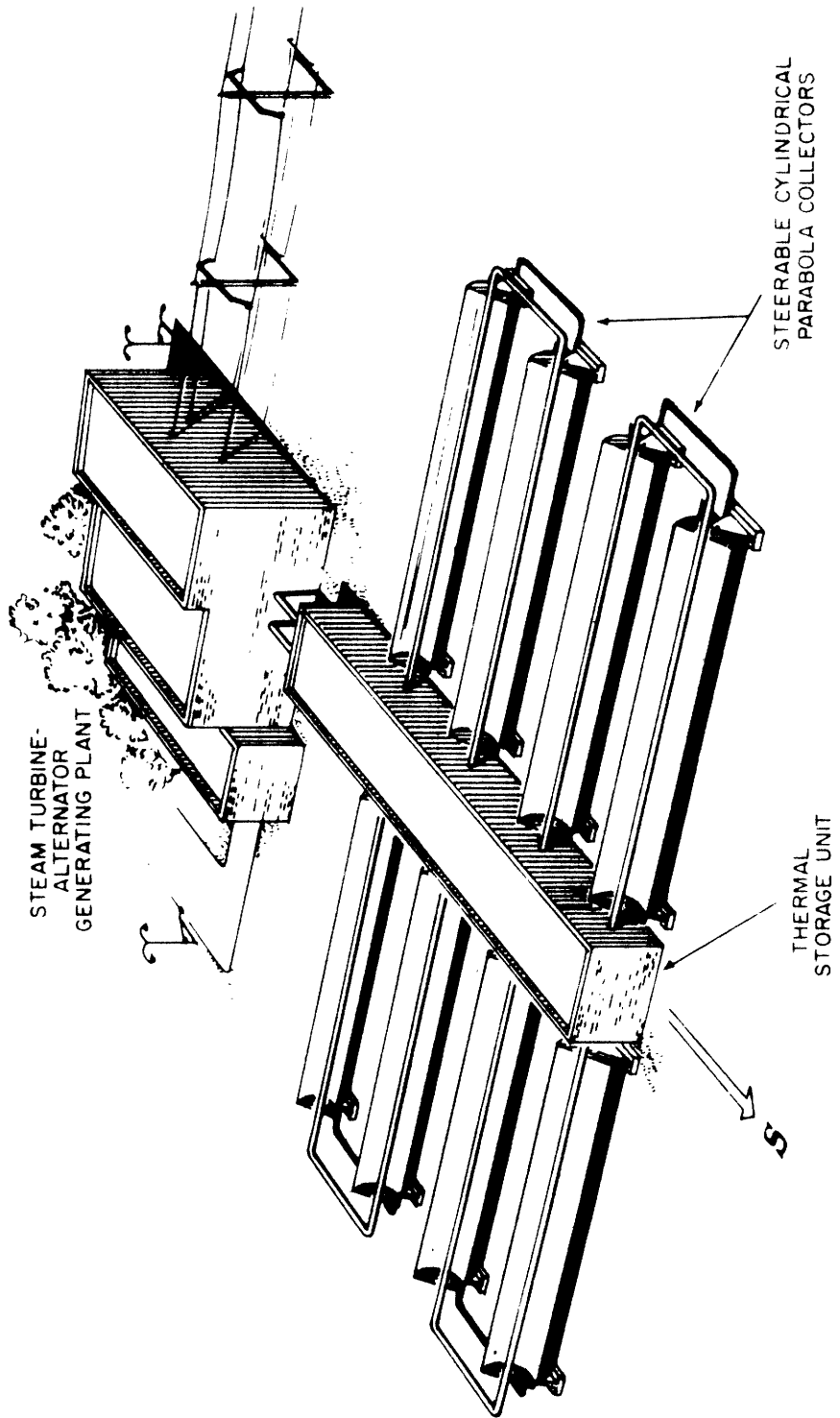

Fig. 9: Solar-Ground-Based Electric Generating Plant using Single-Axis Steerable Concentrators

Reference 9

In addition to the solar/thermal collection elements, a thermal storage subsystem will be required in order to satisfy energy generation deficiencies at night and on cloudy days. A long-term chemical storage system can be used to convert surplus solar power generated during the summer months into hydrogen or a hydrocarbon fuel that can be burned in the winter to make up the deficiency in sunlight. Optimum design of energy storage subsystems is required to minimize the total amount of solar collector surface area required for a fixed, steady electrical generating capacity. The general relationship of both a short-term thermal storage and long-term chemical storage to the solar farm concept is shown schematically in Figure 10.

3. Energy Storage

Any practical solar energy system for large scale electrical power production must include efficient methods for both short- and long-term energy storage.

Short-term storage systems include chemical batteries, mechanical fly-wheels and thermal storage.¹ Table II shows the capability for candidate systems.

TABLE II

<u>Sensible Heat Storage Materials</u>			
<u>Material</u>	<u>Joules --- Per kg -----</u>	<u>Per Cubic Meter</u>	<u>M³/kg</u>
Water	1.6×10^5	1.6×10^8	1×10^{-3}
Rocks	0.4×10^5	0.5×10^8	$.8 \times 10^{-3}$
Glauber Salt ($\text{Na}_2\text{SO}_4 - 10\text{H}_2\text{O}$)	2.4×10^5	3.5×10^8	$.6 \times 10^{-3}$
<u>Latent Heat Storage Materials</u>			
<u>System</u>	<u>Joules --- Per kg -----</u>	<u>Per Cubic Meter</u>	<u>M³/kg</u>
Rocks Heated to 1000°C	1×10^6	1.68×10^9	$.6 \times 10^{-3}$
Salt Heated to 1000°C	1×10^6	2×10^9	$.5 \times 10^{-3}$
<u>Chemical Storage</u>			
Lead Acid Batteries	0.16×10^6	0.5×10^9	$.32 \times 10^{-3}$

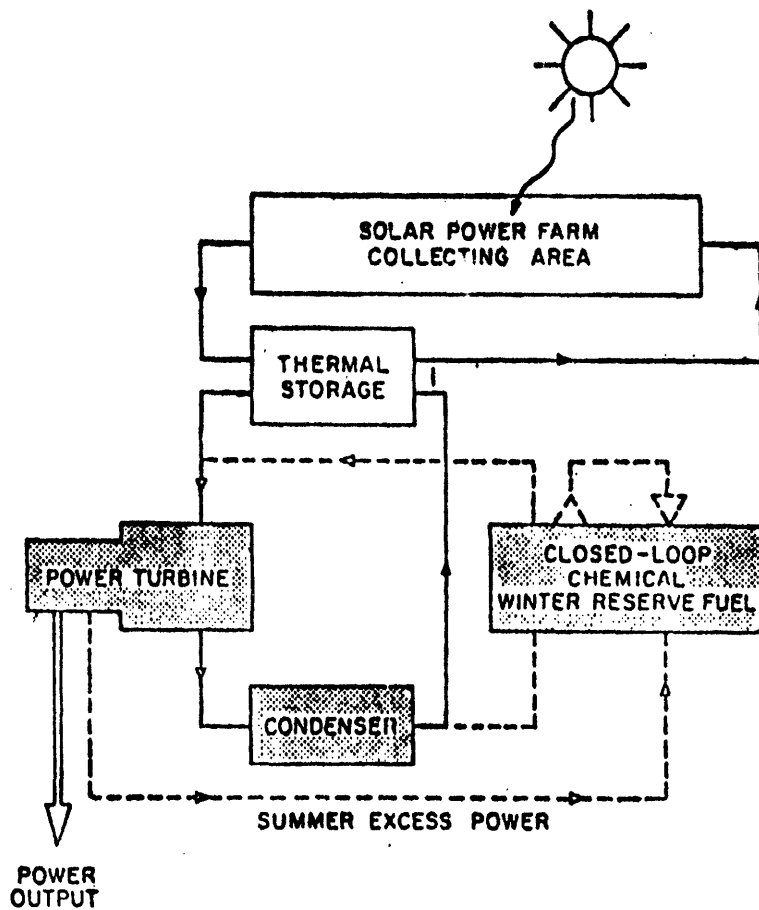

Figure 10

The Meinels' Proposal for a Solar Energy Form (Reference 9)

Because of energy losses, long-term storage must be in the form of fuel storage or pumped water. The most attractive fuel appears to be hydrogen.¹⁶ Stored at high pressure and burned with oxygen, the energy storage capability of hydrogen is:¹⁵

<u>Stored At</u>	<u>Joules/kg</u>	<u>Joules/M³</u>	<u>M³/kg</u>
1 Atm. pressure	15.8×10^6	0.0014×10^9	11.3
100 Atm. pressure	15.8×10^6	0.14×10^9	.113
Liquid	15.8×10^6	1.12×10^9	.014

Electrolysis facilities can convert electricity into hydrogen at a rate of about 25 grams per kW-hr, which is equivalent to an efficiency* of 94%. This would mean that in one day a 1000 MWe plant operating continuously would produce 600,000 kg of hydrogen per day. Such an electrolysis facility is projected¹⁴ to cost about \$100 per kilogram hydrogen produced per day and when stored at 100 Atm. pressure would require about $6.7 \times 10^4 \text{ M}^3$ of storage.

A source of pure water or equipment to capture and recycle the recombined water (result of combustion) is required.

Both hydrogen and oxygen are dangerous gases, so special equipment and handling procedures are necessary.

5. Cooling Facilities

It seems unlikely that a 1000 MWe solar farm (14 km x 14 km) would be located near the ocean or a large lake in New Hampshire. Accordingly, a solar powered steam driven generator would be forced to use a cooling tower facility. The operation of the cooling facility is substantially the same with solar derived energy as with other fuels and therefore the size and cost should be comparable. "As yet no one has built a large dry cooling tower but estimates for a dry cooling facility for a 1000 MWe fossil fuel plant ($\eta = 40\%$) is \$40 to \$60 per kW and \$60 to

* The efficiency for the production of hydrogen has been quoted from 65% to 94%.

\$75 per kW for a nuclear fuel plant ($\eta = 33\%$). The cost of a wet cooling tower for a 1000 MWe plant would be about 50 percent of dry unit cost."*

The actual cost depends upon many factors but data from 20 completed jobs show the cost scatter of \$/kW is $\pm 40\%$.^{22,23} The size required for a natural draft hyperbolic wet cool tower for a 1000 MWe plant is about 125 meters at the base with a height of 115 meters.²⁴

C. Solar Augmented Space Heating and Cooling

Studies show that of all possible uses of solar energy, space heating and cooling has the highest probability of success in the near future.^{12,13,14,17} Even though it is dilute and intermittent, enough solar energy strikes the roof of an ordinary home in New Hampshire to provide several times its annual heating and cooling requirements. The problem is to design systems that will economically capture and store the solar energy until it is needed.

In the past 25 years about 1000** solar heated houses and laboratory structures have been built with various combinations of collector designs, heat storage, heat distribution techniques and auxiliary energy supplies. This work, while generally successful, did not receive much attention because fuel cost has been low and suitable structural and coating materials have been expensive. These buildings were experimental and not readily adaptable to standard construction methods. Past experience has therefore demonstrated technical feasibility of solar-powered space heating but not its practical or economic viability.

Figure 11 illustrates the required components of a system for solar heating and cooling and Figure 12 shows a specific example. Using these diagrams as a reference, some important aspects of each component are discussed.

* Professor L. Glicksman

** Solar Heated Buildings: A Brief Survey. 9th Edition. May 27, 1975, W.A. Shurcliff, Cambridge, Massachusetts.

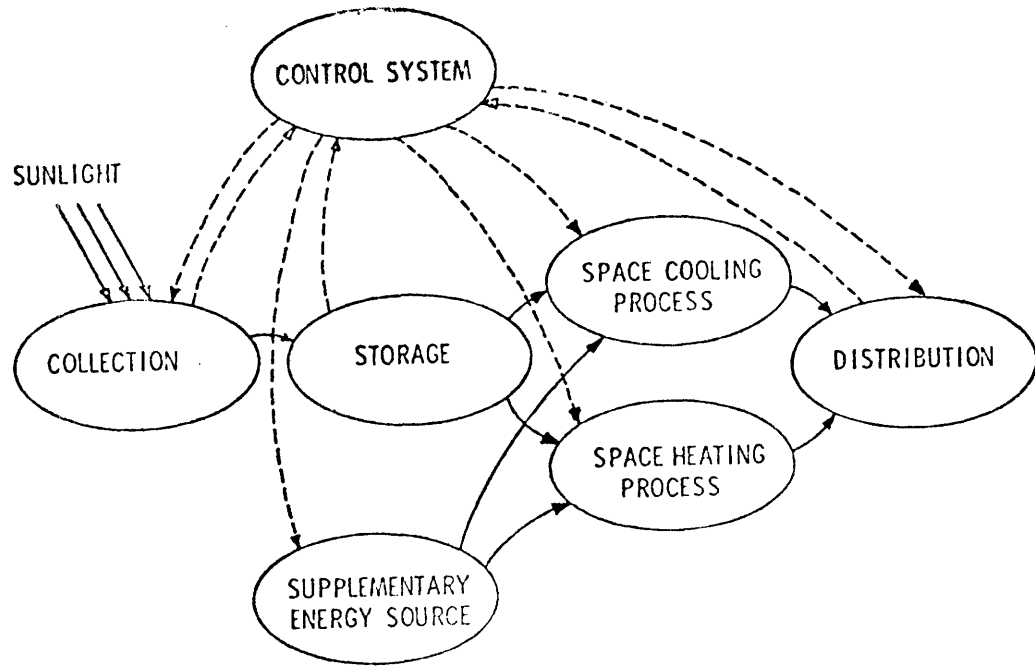

Figure 11: Required Components for Space Conditioning

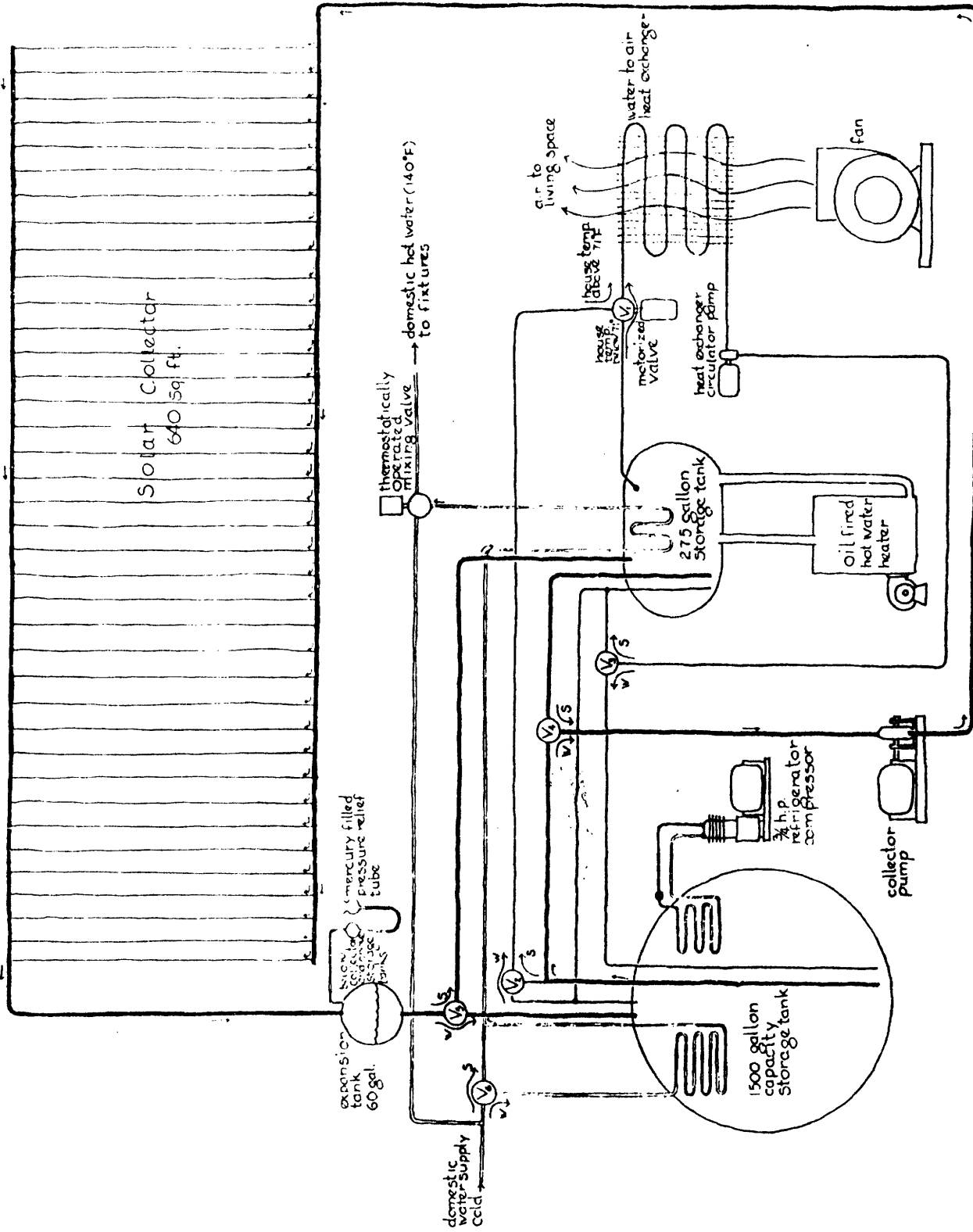

Figure 12: Example of Space Conditioning System

From: "Solar House IV," M.I.T. Press, Cambridge, 1958.

Solar Insolation in New Hampshire

The mean daily irradiance on a horizontal surface in selected geographical locations is shown in Table III. Day to day variations are large, with a typical range between peak and average of 1.5 to 1 in the winter, and 2 to 1 in the summer.^{13,18,19}

The data of Table III show that Concord, New Hampshire, at the peak (July/July), receives solar energy at a rate ($245 \text{ watts}/\text{M}^2$) which is equal only to the yearly average rate in Arizona. Moreover, the 2 to 1 variation in the mean daily solar flux between summer and winter implies long-term (6 months) as well as short-term (daily and weekly) energy storage is required in order to fully utilize the available energy. It is interesting to note that the per capita consumption of energy for the USA for the year 1968 was about 3×10^8 Btu, which is equivalent to a constant power level of about 10 kW per person. The consumption for residential and commercial purposes were each about 20% of the total, or 2 kW per person. Accordingly, an average home in Concord, New Hampshire, assuming six people per home, would need a yearly average of 12 kW. To supply this amount even a December sun would require only a 30 feet by 30 feet area if all the available energy could be collected and stored.

Solar Collectors

Flat plate fluid (including air) collectors are useful in low temperature application up to a temperature of about 85°C of the fluid. They consist of a surface which is a good absorber of solar radiation and a means of removing the absorbed energy by allowing a heat transfer fluid (usually air or water) to flow over the absorbing surface. A major difficulty in collector design is due to the large area for heat transfer which causes heat loss and lower collector efficiency. To limit losses, the back of the collector must be well insulated. The losses from the upper surface are then suppressed by placing one or more transparent surfaces above the absorbing surface. By using materials such as low iron content glass, which are transparent to visible, and opaque to infrared energy, most of the solar energy reaches the absorber, yet the outward heat losses are minimized (greenhouse effect).

TABLE III

Mean Daily Insolation in $\text{Btu}/\text{M}^2\text{-day}$ and $(\text{Watts}/\text{M}^2)$

Area	December		June		Entire Year
	Horizontal Surface	Tilted ¹ Surface	Horizontal Surface	Tilted Surface	Horizontal Surface
Arizona	10,700 (130)		23,000 (340)		20,000 (245)
Entire U.S.	7,500 (90)		23,500 (290)		15,000 (185)
New England	4,250 (50)		17,000 (210)		11,500 (140)
Concord, ² N.H.	5,100 (60)	11,200 (135)	20,000 (245)	19,300 ³ (240)	12,500 (155)

1. Tilt angle equal to latitude, at local noon
2. June/July Average
3. In Concord, New Hampshire, in June, a surface tilted by 45° receives less power than a horizontal surface.

With present designs, flat plate collectors are capable of raising the temperature of heat transfer fluids to approximately 50° above the ambient temperature with an efficiency of 50%. A common method of raising collector fluid temperature is by increasing the number of transparent covers. Typically, one cover will give a 5°C to 34°C increase over ambient, two cover plates 35°C to 55°C , and three covers yield a rise of 55°C to 85°C . Other attempts to increase the temperature-efficiency performance include the use of selective coating of silicon on the absorber, low reflectance coatings on the transparent cover plates, better insulating materials around the back of the collector, and the use of honeycomb material to suppress convection losses. Drawbacks of many selective coatings are their instability (particularly at high temperature) and their high cost. Coating instability could be a problem. In addition, collector maintenance due to freeze-up, dirt, vandalism etc. is a serious consideration.

Current estimates for collector cost range from a low of $\$15/\text{M}^2$ to over $\$100/\text{M}^2$ with an average of about $\$45/\text{M}^2$ using contemporary technology in large volume production.

Thermal Storage

A flat plate collector and a low temperature thermal storage system has the advantage that for space heating, the stored energy is directly usable in thermal form. The success of a thermal storage system is dependent upon the ability to store the thermal energy in a small volume with low loss.

The length of time over which heat is to be stored influences greatly the design and cost of thermal storage systems. Recent studies^{2,20} of solar house heating show that the only systems that presently make sense economically are the partially solar heated house with one or two day storage.

Water and rocks (see Table II) are the most commonly used thermal storage media in solar heating systems. Water is plentiful, inexpensive, and has high specific heat. It works well for collectors with temperatures between 0°C and 100°C . Rocks can be used where air is used for energy transport between collector and storage. Generally, rocks have a lower specific heat (.2 to 1.0) and the storage volume is greater.

Estimates by Tybout and Lof²⁰ show that an optimum system is one with a ratio of about 200 lbs (25 gallons) of water per square meter of collector area. In a typical installation this gives a storage cost of about 50 cents per gallon of water.

Economic Considerations of Space Conditioning with Solar Energy

The cost of solar-thermal space conditioning can be divided into collector cost (i.e. the collector) and utilization cost (i.e. storage, pumps, controls, etc.).

According to one study¹⁷ the collector cost is about $\$45/M^2$ when the collection efficiency is approximately 50%. With a life of 20 years and an interest on capital of 8%, cost for solar heat would be about $\$2.00/10^6$ Btu when (if) all the collected heat can be utilized.

The assumption that all the heat can be effectively utilized implies either an efficient long-term storage system or that demand for heat is uniform over the entire year. The requirements for constant demand is most nearly satisfied by a system that supplies a combination of domestic hot water, heating, and cooling.

Heat energy from coal costs about $\$2.00/10^6$ Btu, and from oil and gas about \$2 to \$3.50 per million Btu. "Therefore, under idealized conditions, the cost of low temperature solar heat appears to be approaching competitiveness."¹⁷

The cost of various storage, pump and control configurations have been studied using computer modeling techniques.^{17,20} The results for an optimized least cost heating and cooling system indicate that utilization costs are about $\$30/M^2$ of collector area.

Other Aspects of the Use of Solar Energy for Space Conditioning

Due in part to the latitude, but more importantly the climatic conditions in New Hampshire, the use of solar energy is only practical as a supplement to conventional supplies. There are two reasons for this: (1) the extended periods of cloudiness and the attendant variations in the available solar energy make necessary a large amount of long-term energy storage, and (2) the seasonal variations in the available solar energy is out of phase with the heat load demand. As a

consequence, without the use of auxiliary power, the solar collector and thermal storage systems are too large to be economically competitive.

• Studies indicate^{2,13,17,20} that the best balance in the New England area is a system to produce from 33% to 50% of the total space conditioning load. Above this amount the required energy storage system is too large.

• Flat-plate collectors produce temperatures in a range from 0°C to 85°C which is compatible with the technology that is now used in hot water storage and distribution systems for homes.

• The bulk of the solar input occurs around noon (in New Hampshire, in December, 60% in three hours). Consequently, some thermal storage is necessary. These self-contained storage systems can be "charged" electrically during periods of off-peak loads and therefore can represent an effective means for cutting peak loads.

• Solar energy is more competitive when used with new buildings; one of the basic requirements is that solar-powered buildings must be as well-insulated as possible. It is also important to make maximum use of natural ventilation. Typically, new structures designed for solar space conditioning would emphasize energy efficiency. For example, walls and roof must be as small as is compatible with the space requirements. The outside skin of the building must be selected with good thermal performance. For air conditioning (cooling) purposes, all windows facing south should be equipped with moveable overhangs (one wants to accept solar heat in the winter), and all other windows sized to reduce heat exchange.

• In order for solar space conditioning to be effectively utilized, architectural concepts and construction practices will have to change somewhat from the recent past.²¹ For implementation of this technology, means to overcome what are essentially social problems are likely to be necessary. Developing the technology is not enough because the fragmented building industry is traditionally slow to adopt new techniques. Also, solar assisted heating systems, despite their lower fuel cost, will entail higher initial cost, thus discouraging consumer acceptance. In any event, the slow rate of replacement of housing guarantees that it will be several decades before a new heating system will have a significant impact on total energy use.

In relation to the total energy consumed in New Hampshire, solar derived power is destined to remain small. Nevertheless, solar space conditioning can have a significant and favorable impact on electric utilities. There are several reasons for this: (1) the solar input is generally consistent* with the time of daily peak electrical demand; (2) the installation (first) cost of solar/thermal conditioning systems tend to be high while the first cost of electric heating systems tend to be low. Accordingly,** it is reasonable to combine the two installations using electrical energy as the auxiliary source of energy; (3) electrically powered hot water storage systems are easy to install, simple to operate and maintain; and (4) thermal storage units can be routinely charged at off-peak hours using base load facilities.

III. SUMMARY

Solar energy can be characterized as being identical to the radiation from a black body at 6000⁰K. Although its thermodynamic potential is high, solar flux is dilute and therefore solar collectors are large area devices.

The least developed technique for utilizing solar energy is the large scale production of electric power. Substantial capital cost reductions are necessary, perhaps by a factor of 10 using thermal conversion and a factor of 100 using photovoltaic conversion techniques. In order to achieve reductions of this magnitude, much work will need to be done to obtain low cost materials and material processing methods.

There is strong evidence that a large market exists for solar

* Generally consistent with the time of daily peak electrical demand means: peak solar input is between 10:30 a.m. and 1:30 p.m. during which the solar powered hot water storage is charged as much as it will be by, say, 2:00 p.m. It is available and can be used for space heating during the (5-6) p.m. daily customer peak for electricity.

** If solar/thermal space conditioning systems are to be used and the first-cost do tend to be high, then it is indeed fortuitous that it is easy to add an electrical heating element to the hot water storage of the solar system. The demand for electricity for this purpose can be made to coincide with the off-peak electrical hours of the bulk, central generation plant.

heating and cooling in residential and commercial buildings. Here little additional development effort is needed and future improvements in the performance and cost of roof collectors, etc. will only hasten the acceptance of solar augmented space conditioning. An important economic consideration is the fact that in any space conditioning system that utilizes solar/thermal energy there is a need for auxiliary heat energy in order to obtain a minimum-cost system. Because of this and the fact that most structures are installed with heating (and cooling) on a lowest-cost basis, a combination of solar/thermal and electrical auxiliary power appears to offer substantial benefits to both the consumer and utilities.

The present status of solar utilization is summarized by Table IV.

TABLE IV
Present Status of Solar Utilization

Technique	STATUS					
	Research	Development	System Test	Full-Scale Demonstration	Model Plant	Commercial Readiness
<u>Thermal Energy for Buildings</u>						
Water Heating - - - - -	X	X	X	X	X	X
Space Heating - - - - -	X	X	X	X		
Space Cooling - - - - -	X	X	X			
Combined System - - - - -	X	X	X			
<u>Electric Power Generation</u>						
Thermal Conversion- - - - -	X					
Photovoltaic						
Residential - - - - -	X	X				
Commercial- - - - -	X	X				
Ground Central Station- - - - -	X					
Space Central Station - - - - -	X					

REFERENCES

- (1) H.C. Hottel, "Residential Uses of Solar Energy," Publication No. 60 of the Cabot Solar Energy Conversion Research Project, M.I.T. P-104.
- (2) H.C. Hottel, and J.B. Howard, "New Energy Technology, Some Facts and Assessments," The M.I.T. Press, Cambridge, Massachusetts, 1971.
- (3) P.C. Putnam, "Power from the Wind," D. Van Nostrand Co., Inc. 1948.
- (4) W.E. Heronemus, Preprints "8th Annual Conference and Exposition, Marine Technology Society," September 11-13, 1972, Washington, D.C.
- (5) C.M. Summer, "The Conversion of Energy Review Article," Scientific American, September 1972, p. 148.
- (6) G.O.G. Lof, J.A. Duffie and C.O. Smith, "World Distribution of Solar Radiation," Report No. 21, Solar Energy Laboratory, The University of Wisconsin, July, 1966.
- (7) P. Glaser et al, "Feasibility Study of Satellite Solar Power Stations," NASA Report CR 2573, February, 1974.
- (8) F. Daniels, "Direct Use of the Sun Energy," Yale University Press, 1964.
- (9) A.B. Meinel and M.P. Meinel, "Physics Looks at Solar Energy," Physics Today, February, 1972, p. 44.
- (10) Solar Energy as a National Energy Resource, a Report of the NSF/NASA Solar Energy Panel, University of Maryland, December, 1972.
- (11) Palz, W., Besson, J., Fremy, J. Duy, T. Nguyen, Vedel, J., "Analysis of the Performance and Stability of CdS Solar Cells," Proceedings of the 9th IEEE Photovoltaic Specialists Conference, Silver Spring, Maryland, May 2-4, 1972.
- (12) Bernatowics, D.T. and Brandhorst, H.W., Jr., "The Degradation of Cu_2S -CdS Thin Film Solar Cells Under Simulated Orbital Conditions," Conference record of the 8th IEEE Photovoltaic Specialists Conference, Seattle, Washington, pp. 24-29, August 4-6, 1972.
- (13) A.D. Little Inc., Solar Heated and Cooled Office Buildings for Massachusetts Audubon Society, Final Report, June, 1973.
- (14) F.R. Eldrige, Solar Energy Systems, The MITRE Corporation, Technical Study M73-26, March, 1973.

- (15) W.E. Morrow, Jr., "Solar Energy Utilization," M.I.T. Lincoln Laboratory, June, 1973.
- (16) D.P. Gregory, "The Hydrogen Economy," Scientific American 228, 13 (1973); L.W. Jones, "Liquid Hydrogen as a Fuel for the Future," Science 174, 367 (1971); W.E. Winsche, T.V. Sheehan, and K.L. Hoffman, "Hydrogen -- A Clean Fuel for Urban Areas," 1971 Inter-society Energy Conversion Engineering Conference, p. 23.
- (17) Terrestrial Applications of Solar Technology and Research, Final Report, NASA Grant Study, School of Engineering, Auburn University, September, 1973.
- (18) 3-16 -- Climatic Atlas of the United States, U.S. Government Printing Office, 1968.
- (19) 3-17, Kusuda, T., editor, Use of Computers for Environmental Engineering Related to Buildings, U.S. Government Printing Office, 1971, p. 202.
- (20) Tybout and Lof, Solar House Heating Natural Resource Journal, Vol. 10, April, 1970, pp. 263-325.
- (21) A.L. Hammond, Research News, Solar Energy, the Largest Source, Science, Vol. 177, September 22, 1972, pp. 1088-1090.
- (22) J. Dickey, Jr., R. Cates, Managing Waste Heat with the Water Cooling Tower, 2nd edition, The Marley Company, Mission, Texas.
- (23) R. Budenholzer, "Selecting Heat Rejection Systems for Future Steam-Electric Power Plants," Combustion, October, 1972, pp. 30-37.
- (24) Foster Wheeler Corp. Heat Engineering Vol. XXXXVI, No. 7, April, 1974.

Richard H. Baker
December 1, 1974
Amended June, 1975
William J. Jones

Monograph No. 2
MIT Energy Laboratory
WIND ENERGY

Wind Energy

Wind energy is not distributed evenly over the globe. On the average it is more plentiful in temperate and polar latitudes. Also, it is generally higher in coastal areas than inland. Wind velocity increases logarithmically with altitude up to the heights which one would consider in windmill (turbine) use and its flow patterns near the ground are strongly influenced by topography. New England is one of the earth's windy regions; the world's record wind velocity, 231 m.p.h., was recorded on top of Mount Washington on April 12, 1934.

Aeolian energy, as wind energy is sometimes referred to, is widely available, inexhaustible, clean and free. There is no question that it works; it has been used for centuries serving individuals or small group users. Like hydroelectric power it can be used directly for the generation of electricity without the large losses associated with thermal to mechanical energy conversion. But wind energy is intermittent, variable and is diffuse. Consequently, its utilization (like solar) [for bulk central power generation] requires a large number of collectors and adequate storage systems.

In New Hampshire large scale use of wind power for the generation of electricity is possible.¹ It is a windy region with abundant high mountains (forty-four over 4000 ft. elevation) near large population centers.

Large-Scale Electrical Power Generation

In order to be practical, large-scale wind-powered generating systems must have a good site location with a high mean wind velocity. The wind turbine must have an efficient aerodynamic design to operate over a wide range of wind speeds, and the electrical system must be properly integrated with established power grids. This requires careful voltage and frequency

control of the power output which otherwise would be just as variable as the wind.

Site Location

The energy available is proportional to the cube of the wind velocity. The wind velocity increases and turbulence decreases with height above the surrounding ground. Mountain peaks, therefore, as well as high narrow ridges running in a north-south direction are good potential sites.¹ The repeatability of the pattern from year to year is also important. The best overall descriptor is a wind Velocity-Duration Curve. From these data and the characteristics of the wind turbine, the total utilization factor (kWhr/year generated per kW machine capacity) can be calculated. Other important site/wind factors are the frequency-distribution of wind direction, the vertical distribution of both the horizontal and vertical components of the wind velocity, the characteristics of gust fronts, etc.¹ These data are not now available for New Hampshire except for Mount Washington.

Large Wind Turbines

Wind has low energy per unit area. Because of this, wind turbines are necessarily large and must be designed to operate efficiently over a wide range of torque speed and load conditions. Present rotor designs are low solidity, high tip-speed, high stress structures.² Some of the technical design problems are: 1) determination of vibratory loads in presence of windshears resulting from earth boundary layers; 2) aeroelastic instabilities including effects of high coning angles and stall flutter; 3) control for optimum power output and speed regulation; 4) protection from high winds; and 5) icing on turbine or fan blades and on supporting structures.

The only large American wind turbine ever built and tested was in Vermont.¹ This machine was designed to produce 1.2 megawatts in a 35 m.p.h. wind with an overall efficiency of 30%. It had two 8 ton blades (175' tip to tip), one of which failed from metal fatigue.

The energy in a wind stream is proportional to $\frac{1}{2} \rho A V^3$ where ρ is the density of the air, A is the area, and V the wind velocity. The maximum power that a windmill can extract from an air stream is 59.3%³ of the kinetic

energy passing through the area swept by the blades. Windmills of good aerodynamic design can achieve about 70% of the theoretical maximum, i.e., 41.5%.

The output from a windmill increases linearly with the area, or as R^2 ($A = \pi R^2$), while blade stress increases as R^3 . This "square-cube" relationship limits the maximum size of a windmill because of the diminished power to weight ratio.

With available materials, the largest size windmills presently envisioned are about 200' tip to tip, mounted on a tower about 150 feet high. Studies^{1,2,4} indicate that such a windmill (located at a suitable site) would be a nearly optimum design and could produce up to 10 MWe at a cost between \$350 per kW and \$400 per kW of installed capacity. To generate the equivalent output of a single fossil fuel or nuclear 1000 MWe plant would require a hundred of these windmills. These windmills will produce that amount of power only for a small fraction of the day.

Windmill Control and Integration with Existing Power Grids

There are two ways to design a wind turbine to operate efficiently over a wide range of wind speeds. One is to allow the windmill to operate at a constant blade-tip to wind speed ratio and design the load to absorb power as the cube of the wind speed. The other is to change the blade pitch, thereby varying the torque but keeping the blades at a constant rpm. The constant-pitch, variable-speed system is simpler mechanically but requires a frequency-controlled alternator. Direct nonsynchronous machines, where the variable ac is converted to dc and back to ac again, using batteries for the intermediate storage, have also been proposed.^{2,5} This type of conversion has the advantage of decoupling the variable frequency windmills from the mixed power grid.²

In order to avoid double conversion losses, it is important to utilize wind energy on-line as much as possible. On the other hand, in order to extract the maximum average energy available from an intermittent and variable wind system, it is necessary to have an energy storage facility.

Candidate storage systems include: Secondary batteries which have the advantage of storing at an overall efficiency of about 75%. Energy densities

are from 10 to 100 watt-hours/pound and 30 to 100 watts per pound with a battery life of about five years. The cost is estimated² at about \$80 per kilowatt hour. The use of battery storage systems are now being studied from critical materials standpoint (lead and zinc).

Pumped water storage systems are quoted at 67% efficiency and at a typical cost of \$180 per kilowatt hour.²

Compressed air storage is about 67% efficient and would cost about \$100/kW of installed capacity.

A system for the electrolysis of water to produce hydrogen is a popular concept.^{1,2,6} Cost estimates vary from \$100 to \$250 per kilowatt of installed capacity.⁹ One problem is the availability of suitable pure water for electrolysis.¹ The feasibility of storing hydrogen in the gaseous state along with the problem of hydrogen induced embrittlement of metals is also being studied.

The availability of water and the need for high pressure storage has led some to propose an off-shore-wind program with windmills out in the ocean off the coast of New England.^{6,10} The arguments are that the wind is more consistent, there is abundant water for electrolysis, and the hydrogen can be securely stored in deep water at very high pressure.

Considerable research is required to determine the effects of seasonal variations in wind direction, velocity range, gusts, and sea state. A salt water/atmosphere environment is very hostile to machinery and electrical equipment. The combined effects of corrosion and hydrogen embrittlement on the hydrogen storage tanks must be predictable.

Off-shore oil drilling and production platforms for anchorage in depths of water up to 300 feet have been in use for some time. A wind-power system designed and constructed to survive the combined forces and stresses due to ocean currents (surface and sub-surface), wind gusts, yawing due to attempts to remain orthogonal to wind direction, and the Coriolis force (effect of earth rotation) is a significant engineering task.

Studies Concerning Small Windmill Systems

Before 1950, when rural electrification became widely used, about 50,000 small windmills were used in the midwest. The enactment of the Rural Electrification Act brought low cost, reliable central generating station electricity to the farms.

It is interesting to note that wind energy is now being evaluated as a supplemental fuel in megawatt-size wind turbines, and medium size (100kW) installations that may also combine water electrolysis and fuel cells for commercial power production.²

Consideration of the use of windmills to produce supplemental energy for individual residential and small commercial applications is also growing. However, such wind systems, complete with tower structure, windmill, storage batteries, and dc to ac inverters are available with ratings of 10 to 1000kW-hour/month at a cost of about \$1,500/kW capacity.⁷ In addition, the owner would either have to be technically competent or hire persons to maintain such systems.

Results from on-going research and development efforts appear to offer much improved performance by simpler systems. Both the National Science Foundation and the Energy Research and Development Agency are funding R & D efforts, albeit the total dollar funding is considered by many to be too low. Horizontal-Axis Wind Turbine Studies include:

- NASA, 125' diameter, 100 kW-turbine design emphasizing a low-cost technology. This system is designed to operate directly into a power system grid without storage and is scheduled to be operational in July, 1975.
- Oklahoma State University, Bicycle-wheel Turbine; high-lift/low-drag structure designed for light weight and low cost. Early results indicate the efficiency is close to the theoretical limit of 59%.
- Princeton University, 25' diameter Sailwing. The blades have a cross section similar to a high performance glider wing giving maximum lift and minimum weight. Both Grumman and Fairchild are working with the design. Results to date are

outstanding, the lift/drag ratio is 20:1, the complete wing weighs only 44 pounds and has survived 160 knot wind tests.

The Darrieus Vertical-Axis wind rotor was invented in 1931. The vertical-axis configuration has the advantage that its operation does not depend upon the wind direction and therefore it has a high potential for high efficiency in rapidly varying wind directions. This, together with the advantage that the output is at the bottom of the structure, simplifies the design, reduces cost and allows wind power to be used in more turbulent wind patterns.^{2,8} A disadvantage is that the device is supported only at the base and the foundation and bearings are subject to high bending forces.

Summary

It appears that the earliest application of modern wind power will be, as it has been in the past, to meet individual or small community needs supplementing the more conventional sources. This allows efficient utilization of the distributed nature of wind energy. There are a number of active research programs in this area.

Conceptual designs for large central power plants have been done and cost estimates made. We have little practical experience with even the components of such large systems. The construction of large plants would involve substantial risk. No environmental impact analyses have been made.

Present cost ranges appear to be as follows:

Wind Turbine: \$350 - \$400 per kW installed capacity.

Storage:

Pumped Water: \$180 - \$220 per kilowatt hour

Electrolysis of Water: \$100 - \$250 per kilowatt installed capacity.

Hydrogen Storage

(High Pressure System): \$75 - \$110 per kWh - day.

Batteries: \$80 - \$100 per kilowatt hour.

Compressed Air: \$80 - \$100 per kilowatt hour.

System Integration and Control:

In order to make a realistic estimate of cost for the integration and control of a large windmill system into the existing power system, it is necessary to know in fair detail the quantity or quality of the wind in New Hampshire. The trade-offs are complex; for example, if the windmills are clustered in one region, the cost of crew housing, power transmission, etc. are reduced. On the other hand, if 200 or 300 windmills are widely dispersed, the total output power produced by the "wind-grid" would probably be more even and therefore require less energy storage capacity, etc. Maintenance costs for the windmill would be increased by its remoteness; however, the windmill is less complex than some other systems, etc. As a guess, a first-cost of \$100 per kWh installed capacity for system integration and control, along with 5% per year maintenance, might be reasonable.

In order to develop a dispersed wind energy powered electric generation utility, a number of issues, actions and developments must take place.

- 1) The state or region must be surveyed for average, peak, and gustiness of winds, preferably over a span of a few years.
- 2) Assemblage of data on icing conditions and snow fall amounts.
- 3) Determination of site availability, access to and from for construction, maintenance and coupling to regional electrical grid.
- 4) Selection of optimum size and support structure for each site.
- 5) Establishment schedules for that portion of electricity obtained from wind energy.

The time necessary to accomplish the above for a system that would deliver 1000 megawatts average would be in the order of ten to fifteen years.

REFERENCES

1. P.C. Putnam, Power from the Wind. D. Van Nostrand Company, Inc., 1948.
2. Wind Energy Conversion Systems, Workshop Proceedings, NSF/NASA, Washington, D.C., June 1973.
3. H. Glavert, The Elements of Airfoil and Airscrew Theory. Cambridge University Press, 1948.
4. N. Wade, "Windmill Technology," Science, Vol. 184, June 7, 1974, pp. 1055-1058.
5. R.H. Miller et.al., Research on Wind Energy Conversion Systems, Proposal submitted to NSF from MIT Department of Aeronautics and Astronautics, July 1, 1974.
6. W.E. Heronemus, "Reprints, 8 Annual Conference and Exposition, Marine Technology Society." Washington, D.C. (C) 1972 MTS, September 11-13, 1972.
7. K. King, Sales Agent, Solar Wind Company, Fryeburg, Maine.
8. P. South and R. Rangi, "The Performance and Economics of Vertical-Axis Wind Turbines." Presented at 1973 Annual Meeting of the Northwest Region of the American Society of Agricultural Engineers, Calgary, Alberta, October 10-12, 1973.
9. Elihu Feie, "A Hydrogen Based Economy," Report 69-09-10, The Futures Group, Glastonbury, Connecticut, October 1972.
10. Dambolena, I.E., "A Planning Methodology for the Analysis and Design of Wind-Power Systems," PhD Dissertation, University of Massachusetts, January 1974.

Monograph No. 3
MIT Energy Laboratory
OCEAN THERMAL ENERGY CONVERSION

Sea water is always colder at depth.* Surface waters are warmed by capturing solar energy and storing it. The deeper one goes the colder it is, and often approaches the freezing point. The possibility of using heat engines, operating on the temperature difference between surface and deep waters to produce electricity for direct use or for production of fuel, perhaps hydrogen, excites the interest of scientists and industrialists alike.

The maximum absolute temperature and the maximum temperature differential of surface and deep waters varies with latitude. In the region between 20°N and 20°S the differentials encountered are sufficient¹ (20°C) to vaporize other working fluids (freon, ammonia, etc.). The lower temperature behavior characteristics of such fluids permit one to operate turbines and hence generate electricity.⁸ (see Figures 1, 2 and 3).

Between the Tropic of Cancer 23°N and the Tropic of Capricorn 23°S , the ocean's surface stays almost constantly at 25° because of the heat collected from the sun and heat lost due to evaporation and other processes.

This warm water moves toward the poles (the Gulf Stream is one ocean current in the Atlantic Ocean) where it melts the ice. The water of the melted ice is very cold, hence much denser than the surface water. The cold water sinks to the ocean floor where it moves towards the equator and upwells to replace the warm surface water that has moved towards the poles. In the tropics the water at depths of 3000 feet is about 5°C . It is in this region only that solar/sea electric power generation is possible.

The efficiency of an ocean thermal generating plant would be very low. The maximum thermodynamic efficiency for a temperature differential of ten to twenty degrees for the working fluid, which corresponds to an

* There are situations where this may not be so, but are not pertinent to this discussion.

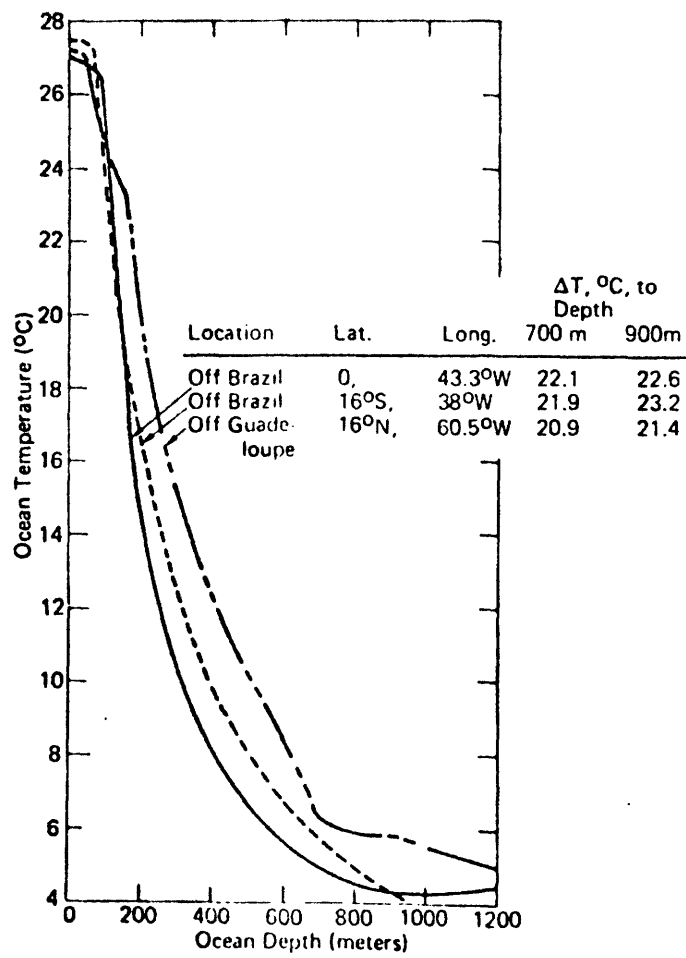

Figure 1: Thermoclines in the Tropical Atlantic Ocean

Reference 8

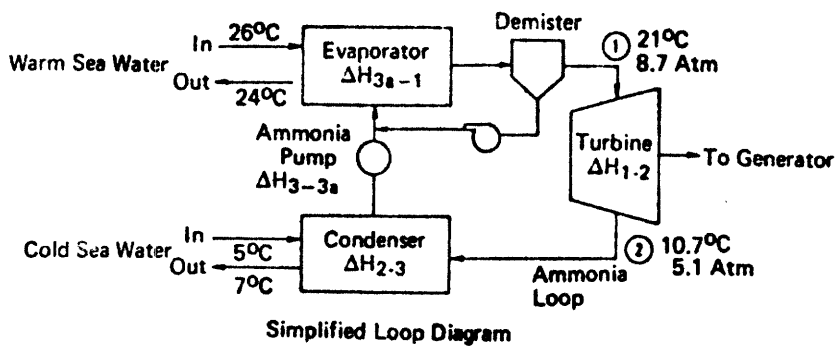

Fig. 2 Simplified loop diagram (for tropical ocean temperatures and ammonia working fluid), T-S diagram, and H-S diagram for the closed-Rankine cycle, Ocean Thermal Energy Conversion (OTEC) plant.

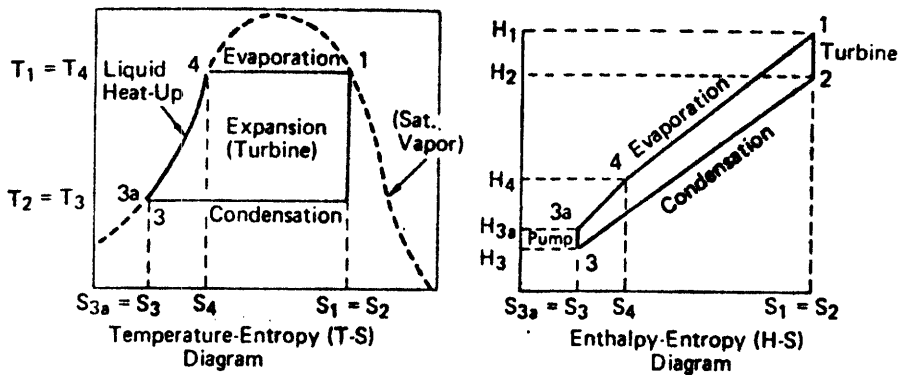
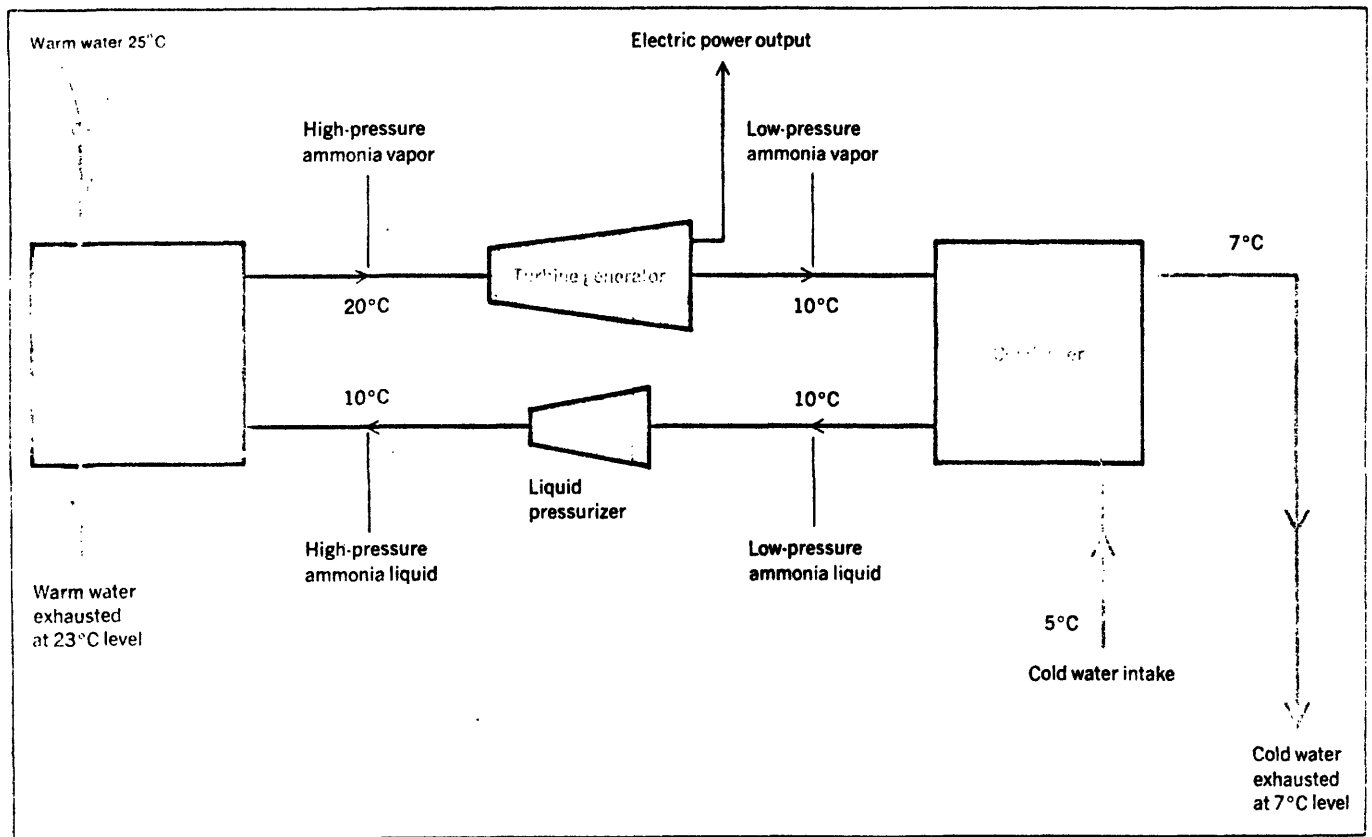

Figure 2



Schematic diagram of a solar sea power plant. Ammonia is assumed to be the working fluid in the boiler, turbine and compressor in this example, but more recently developed refrigerating

fluids, such as the freons, might be preferable. The quantity of water passing through the boiler is comparable with that passing through a hydroelectric plant with the same output.

Figure 3

Source: Zener, Clarence, "Solar Sea Power," *Physics Today*, pp. 48-53, January 1973.

ocean surface/deep temperature difference of 21°C is about 3 percent. Practically, the efficiency obtainable would be no more than 2 to 2.5 percent. This, in itself, is not a serious drawback; the temperature difference (fuel) is free. The low efficiency is important because the size of the plant would be greater than any other type of electric power plant. Large amounts of water must be circulated through the heat exchanger. The costs need not necessarily be greater because the pressure differentials are not great and boilers, heat exchangers and turbines need not be constructed so as to withstand 1500 pound differentials. Solar sea systems can be designed for pressure differentials of only a few pounds. It is the cost-per-kilowatt hour of electricity produced that is most important.

In 1929 a Frenchman, George Claude, built⁹ an ocean thermal gradient power plant in Cuba that produced 22 kW of useful power. The system used sea water as the working fluid which proved to be inefficient because of its low vapor pressure. The system, as a competitor to fossil-fueled plants, was an economic failure at that time.

Anderson and Anderson¹ carried out a detailed study of an ocean thermal power plant in 1966. Their studies resulted in an estimate of capital cost of \$165/kW for a 100 MW sea power plant. At that time, the estimate was comparable to the cost of a conventional fossil-fuel plant.

Fossil-fuel plants currently cost \$350-400/kW and nuclear reactors are now approaching \$500/kW in capital cost. Even if one allows for inflation, ocean thermal power plants are increasingly attractive. Avery's estimates for the cost of a 1000 megawatt (electrical) plant are reproduced as Table 1.

Rust³ estimates a capital cost of approximately \$560 per kilowatt for a solar sea power plant. Hence, a 1000 megawatt power plant would cost 560 million dollars, about twice the estimate of Avery.

Rust³ estimates that the amount of sea water required to produce 1000 MWe would be 5.6×10^{10} pounds per hour (about a hundred million gallons per minute, or over one-third the flow of the Mississippi River) through the condenser. The separation between the inlet ducts for these

ELECTRIC POWER COST AT OTP

CONSTRUCTION COST 1000 MW PLANT	=	\$263M	169M
FIXED CHARGES AT 11.8%		\$ 31M	20M
INCLUDES COST OF MONEY	8.2%		
DEPRECIATION & REPLACEMENTS	1.2%		
INSURANCE	.2%		
INCOME TAXES	2.2%		
OPERATING COSTS		\$ 10M	9M
TOTAL ANNUAL COST		\$ 41M	29M
COST MILLS/KWH		4.67	3.3

3-6

Table I

Source: Avery (2)

10/28/74

two systems would be in the order of 4000 feet. To move these amounts of water over these distances would require considerable energy. Pumping energy requirements could be reduced with large cross section ducts and heat exchangers.

The area of the ocean between latitudes 10° north and 10° south around the earth is about 30 million square miles. The average insolation energy on the surface is about 20 watts per square foot. One may, then, consider this the heat replacement rate. At an extraction efficiency of 3%, 60 square miles 0.0004% of that tropical ocean area, where the depths exceed 2000 feet, would support a 1000 megawatt electric power plant.

A solar sea power plant need not be used to produce only electricity. The warm surface waters in the tropics are often exhausted by the high rate of photosynthesis, of nutrients that are necessary for marine life. The cold water that upwells brings with it large quantities of bottom nutrients and no organisms which produce disease in humans, predators and parasites in shellfish. This formerly bottom water can be used in mariculture (artificial forms of sealife that can be eaten by man or introduced into his food chain). In addition, large quantities of fresh water could be produced for shipment to the shore communities. The combined revenues from power generation, mariculture and desalination, could make solar sea energy development very beneficial.

Ammonia is manufactured for use in the production of chemicals and other products. The principal use is in fertilizers. In the U.S., natural gas is the feedstock for the ammonia factories. Natural gas is in critical short supply. Production of ammonia at an ocean thermal plant would require only nitrogen from the atmosphere and hydrogen from the sea water. Since the demand for fertilizers will continue to increase, the economic attractiveness of such an adjunct to an Ocean Thermal Energy Conversion (OTEC) plant will increase.

On one hand OTEC is very attractive economically; on the other hand, a great expanse of the sea and nearby estuaries would be involved. Pas-kausky⁴ suggests that the environmental impact by the redistribution of dissolved oxygen, nutrients, isotherms and corrosion products needs

thorough investigation because oceanic fauna are much more sensitive than estuarine fauna.

On 13 July 1974, the Solar Energy Task Force of the Project Independence Blueprint Study issued a report on Ocean Thermal Energy Conversion. It describes a program which is designed to "establish the technical, economic, and geopolitical feasibility of large-scale floating power plants capable of converting ocean thermal energy into electrical energy, leading to the commercial utilization of such plants and the production of significant amounts of energy."

The OTEC intends to initiate construction of a proof-of-concept experiment very early in the 1980's. This is expected to lead to a 100 MWe demonstration plant before the middle 1980's and a total production capacity of 1000 MWe by the mid-1980's.

Based on certain assumptions, two scenarios are postulated for availability of ocean thermal powered, electric generating plants:

I. "Business-as-Usual"

1985	1,000 MWe*
1990	4,000 MWe
1995	16,000 MWe
2000	65,000 MWe

II. "Accelerated" (government incentives, etc.)

1985	1,000 MWe
1990	6,300 MWe
1995	40,000 MWe
2000	260,000 MWe

These estimates are based on the belief that the technology required for OTEC is relatively low-level and only a few scientific or technical breakthroughs are required.

* MWe - megawatts of electricity

The authors of the "Blueprint" further acknowledge that environmental consequences cannot be predicted before at least a pilot plant is built. Also, siting limitation associated with availability of thermal resource and of suitable ocean conditions, plus regulatory problems, such as freedom-of-navigations and law-of-the-sea considerations may impose certain limits to the availability of ocean areas for this application.

Such problems as biofouling of components and subsystems, anchoring, mooring, dynamic positioning of materials compatibility and corrosion, construction system and methodology for power plant installation and maintenance are considered "avoidable or corrective." Means of transporting (including conversion and storage, as necessary) large amounts of power generated at a distance at sea is not discussed.

In view of the complete lack of experience in the generation of electricity from solar sea thermal differential, the wide range of capital costs (estimates both for the plant and the transmission lines to the shore) and the nature of the problems anticipated, the timetable of Project Independence Blueprint for OTEC appears rather optimistic.

BIBLIOGRAPHY

- 1) Anderson, J.H. and Anderson, J.H., Mechanical Engineering, U.S. Patent 3 454 081, page 41, April 1966.
- 2) Avery, William H., Ocean Thermal Power, a special presentation to U.S. Senator Mathias and Mr. J. Sawhill of the FEA at the Applied Physics Laboratory of the Johns Hopkins University, October 30, 1974.
- 3) Rust, James H., "More on Solar-Sea Power," Physics Today, pp. 9-13, September 1973.
- 4) Paskausky, David F., "Solar Sea Power Impact," Physics Today, letters p. 15 and 115, January 1974.
- 5) Othmer, D.F. and Roels, O.A., "Power, Fresh Water, and Food from Cold, Deep Sea Water," Science Volume 182, pp. 121-125, October 12, 1973.
- 6) Zener, Clarence, "Solar Sea Power," Physics Today, pp. 48-53, January 1973.
- 7) Metz, William D., "Ocean Temperature Gradients: Solar Power from the Sea," Science Volume 180, pp. 1266-1267, June 22, 1973.
- 8) Avery, et.al., "Tropical Ocean Thermal Powerplants and Potential Products," American Institute of Aeronautics and Astronautics and the American Astronautical Society Conference on Solar Energy for the Earth, AIAA Paper No. 75-617, 21 April 1975, New York, New York 10019.
- 9) Claude, Georges, "Power from Tropical Seas," Mechanical Engineering Volume 93, No. 10, 1971, pp. 21-25.

Monograph No. 4
MIT Energy Laboratory
GEOTHERMAL ENERGY

In man's quest for low cost energy, geothermal energy has met some of his requirements for several thousand years. Hot springs have been contained or the waters channeled to baths, to assist in agriculture, to move machinery directly and, most recently, to generate electricity. As a substitute for fossil and nuclear fuels, it beckons consideration.

Geothermal energy, in the broadest sense, is the natural heat of the earth. One may consider the earth as consisting of a core of molten material at a temperature of 4000°C with ever-increasing layers of material (like skins of an onion) between it and the earth's surface. The temperature decreases as one approaches the surface of the earth. The heat at the center flows out to the surface at a low rate (1.5 calories per square centimeter per second).

The "layers" referred to above are not constant in thickness all over the volumes that they enclose. In addition, there are "breaks," "depressions," and "bumps" which result in an uneven outward flow of heat at certain spots and hence great differences in near surface temperature. The extreme case is an active volcano where there may seem to be a hole or passage from the center core radially outwards to the surface.

A very crude section of the earth is shown in Figures 1 and 2.¹¹ In the outer layer, the crust is composed mostly of rock formations. The base of the crust is about 10 to 50 Km (6-10 miles) below the surface of the earth, with the smaller figure applying under the oceans. As we go down into the earth, the temperature rises by about 10° to 20°C per Km so that temperatures in the crust can rise to as high as 1000°C (1800°F).¹²

Frequently "hot spots" exist where the unevenness of the layers or breaks in some of the "layers" below them allow more heat to flow from the core so that much higher temperatures occur at that place than exist elsewhere beneath the earth's surface at that depth.

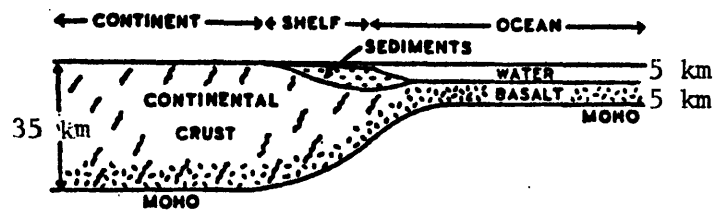
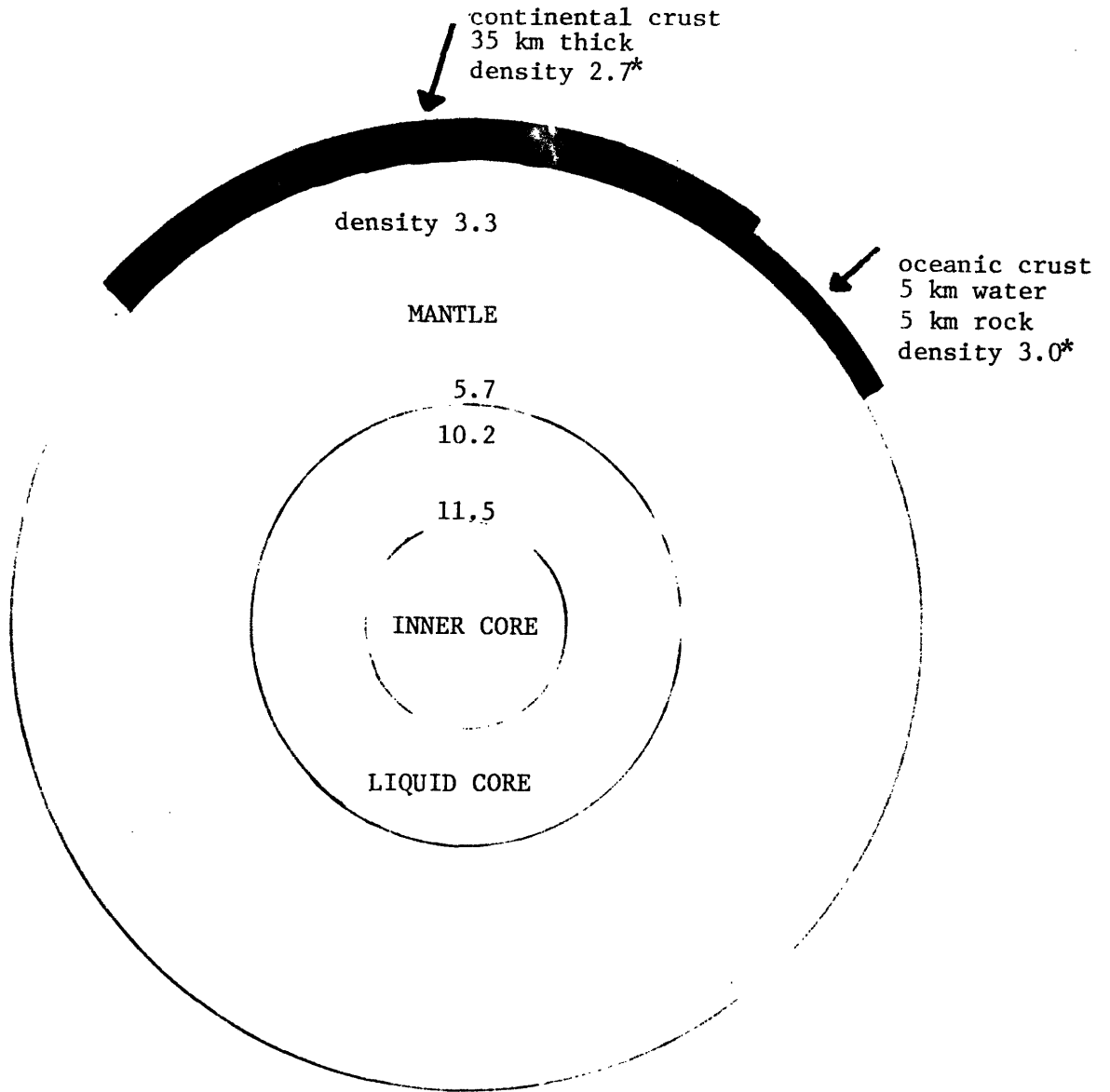

Figure 1: Schematic section through earth's crust at an inactive coastline, such as that of eastern North America.

Reference 11



* not to scale

Figure 2: Crust, mantle and core. The figures are densities in g/cm^3 .

Reference 11

There are locations where the rain (surface) water oozing down through the outer "layers" comes in contact with these "hot spots" (Figure 3). The water is heated, may turn to steam, and force its way to the surface. Depending upon the temperature of the "hot spot" and the path to the surface, the water may emerge as steam, hot water, or a mixture of both. The heated water, at depth, is under pressure and may "flash" to steam upon approaching the surface where the pressure is less.

If seismic and geophysical data so indicate, holes are drilled down towards the irregularities in the contours to "hot rocks." Water is pumped down the holes, and upon contact with the high temperature material, turns to steam and transfers the heat to the surface.

Geothermal resource areas are: 1) areas on the surface of the earth where steam or hot water emerge, or 2) where artificial stimulation is possible because of the "bumps" which are close enough to the surface (less than 9000 feet) to be reached by drilling.

These areas are not evenly distributed over the earth's surface. The west, Alaska and the Virginias are the only such places in 49 of the United States, as Figures 4 and 5 show. Figures 6 and 7*show world-wide distribution. In Hawaii the Center for Science Policy and Technology Assessment of the Governor's office is considering a plan for using the geothermal energy in that state. It is believed that deep-lying hot rock might be used to create electricity-generating steam.

The Hawaiian Islands are volcanic in origin and there are a number of active and dormant volcanoes. The most probable source is on Hawaii, where University of Hawaii scientists are seeking evidence of steam or super-hot water.

New England and the Midwest are almost completely devoid of any opportunities to develop geothermal energy. This is not to say that one cannot obtain geothermal energy in New England. It is the depths to which one must drill and the kinds of materials that will be encountered on the way down which make it very unlikely that it will ever be done, even though geothermal energy may be considered "free." In addition, the energy necessary to pump cold water down and then up again after it has been heated may be greater than that extracted.

* Figures 4-7 are from Armstead, Christopher, editor, "Geothermal Energy: Review of Research and Development" UNESCO, Paris, 1970.

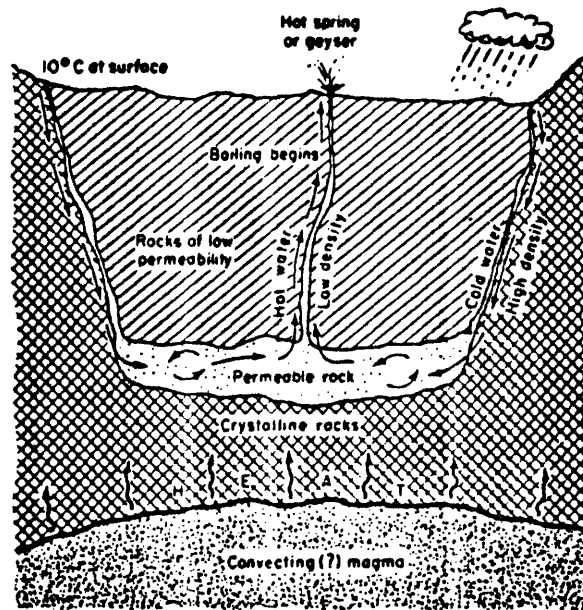
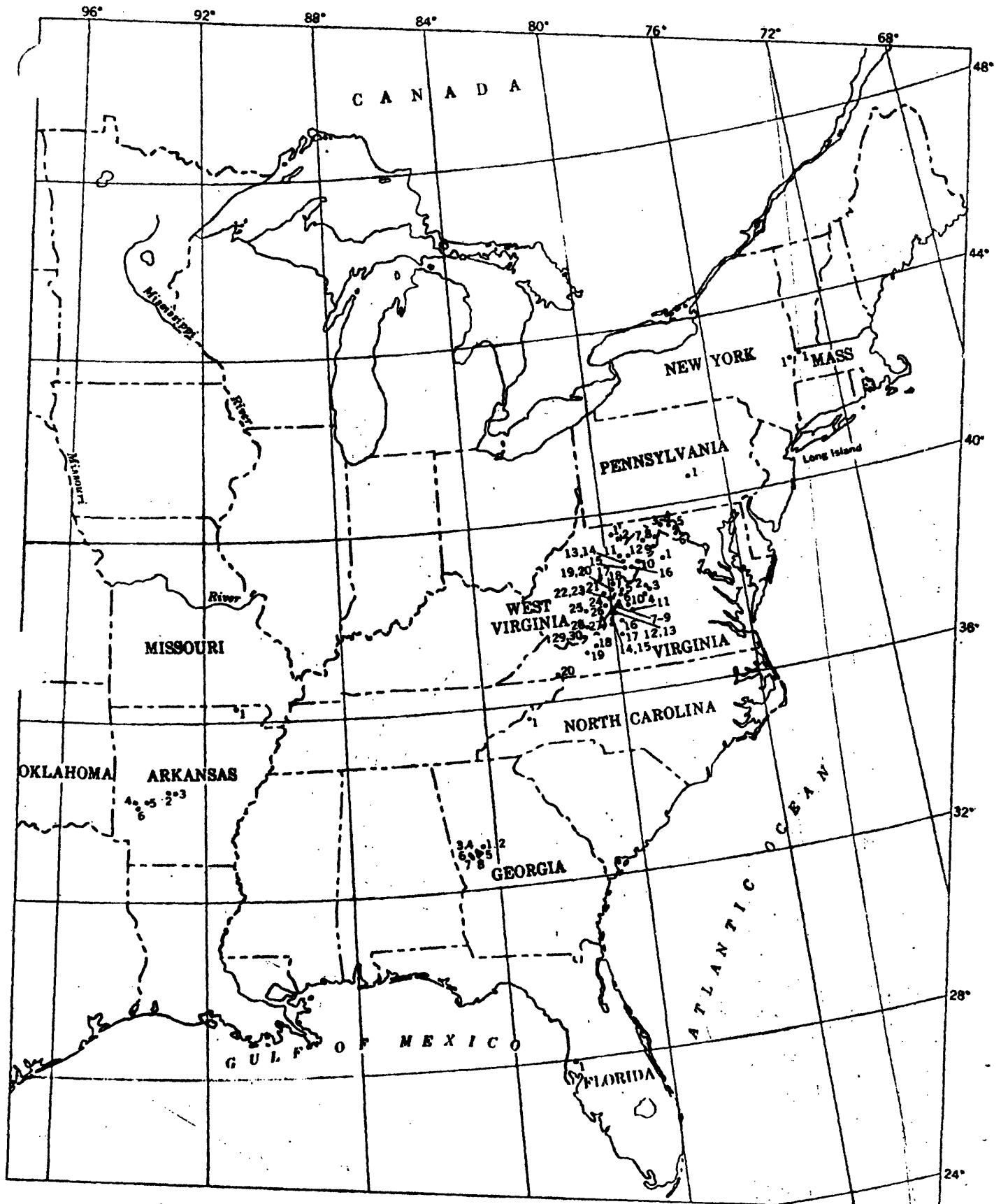

Figure 3: Illustrations of a geothermal field showing how heat can be tapped. Adapted from Muffler, L.J.P., and White, D.E. (1972). *The Science Teacher* 39 (3), p. 40.

DESCRIPTION OF THERMAL SPRINGS



Eastern part of the contiguous United States showing location of thermal springs.

Figure 4

THERMAL SPRINGS OF THE UNITED STATES AND OTHER COUNTRIES OF THE WORLD

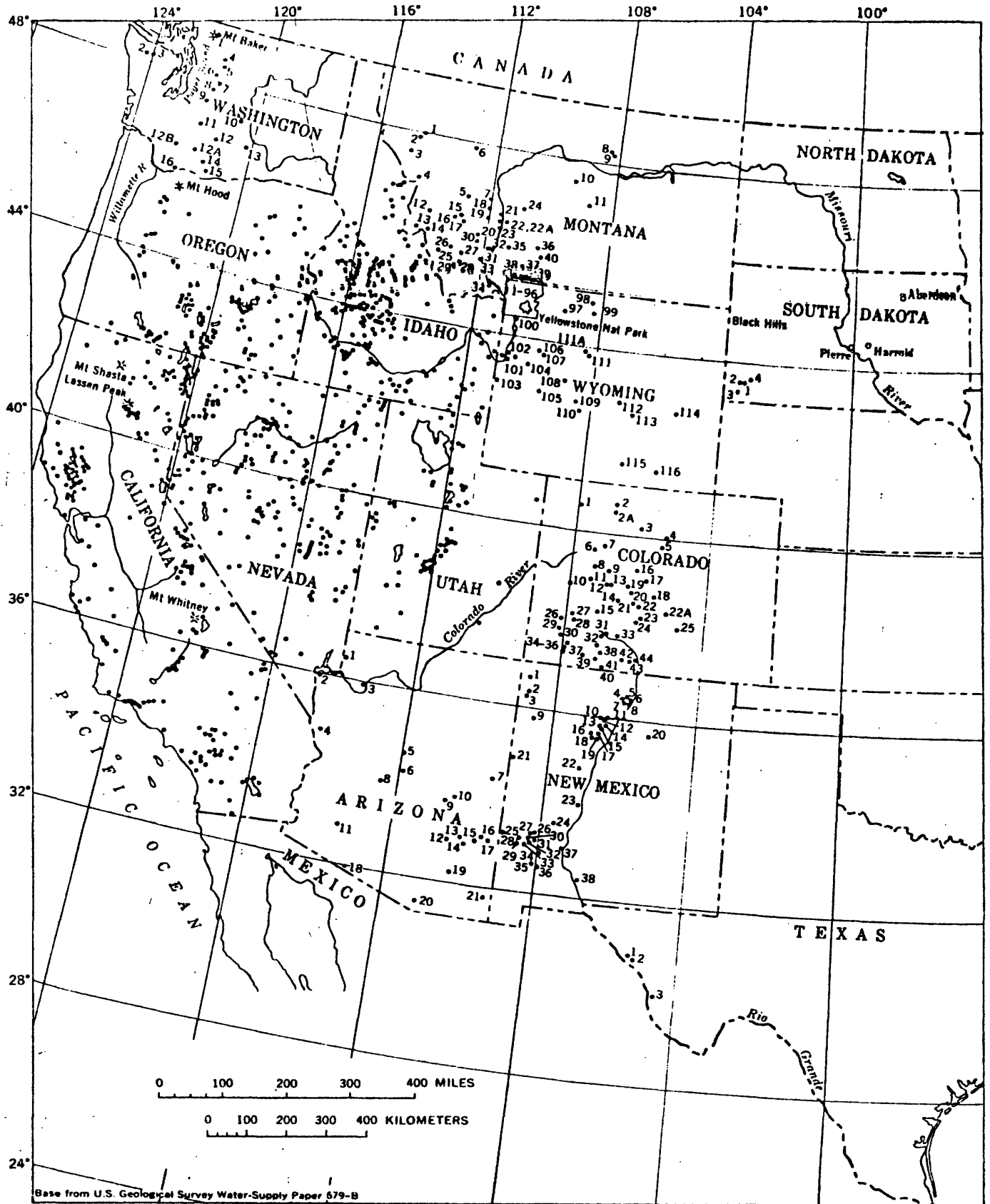

Western part of the conterminous United States showing location of thermal springs.

Figure 5

THERMAL SPRINGS OF THE UNITED STATES AND OTHER COUNTRIES OF THE WORLD

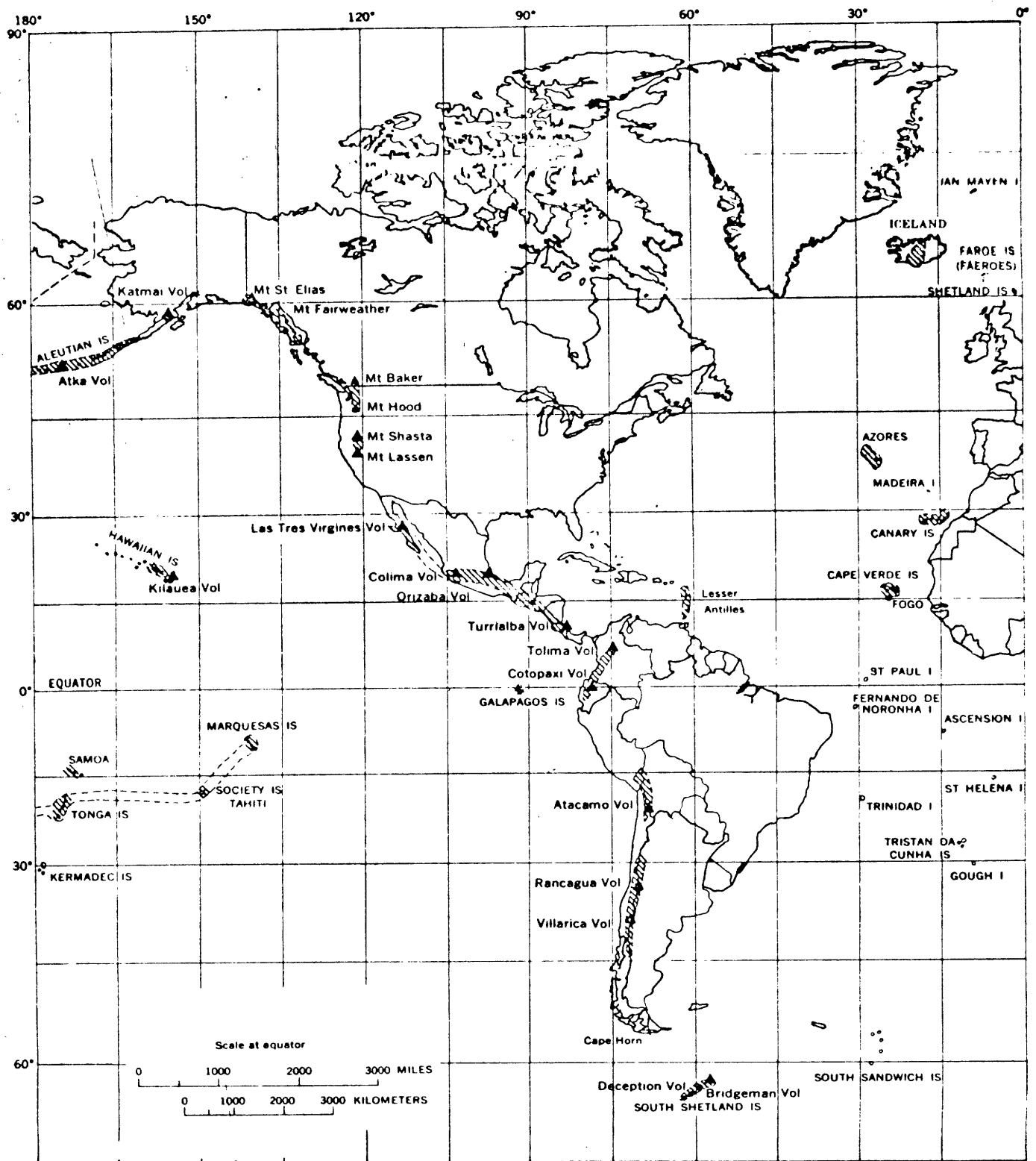

Figure 6

THERMAL SPRINGS

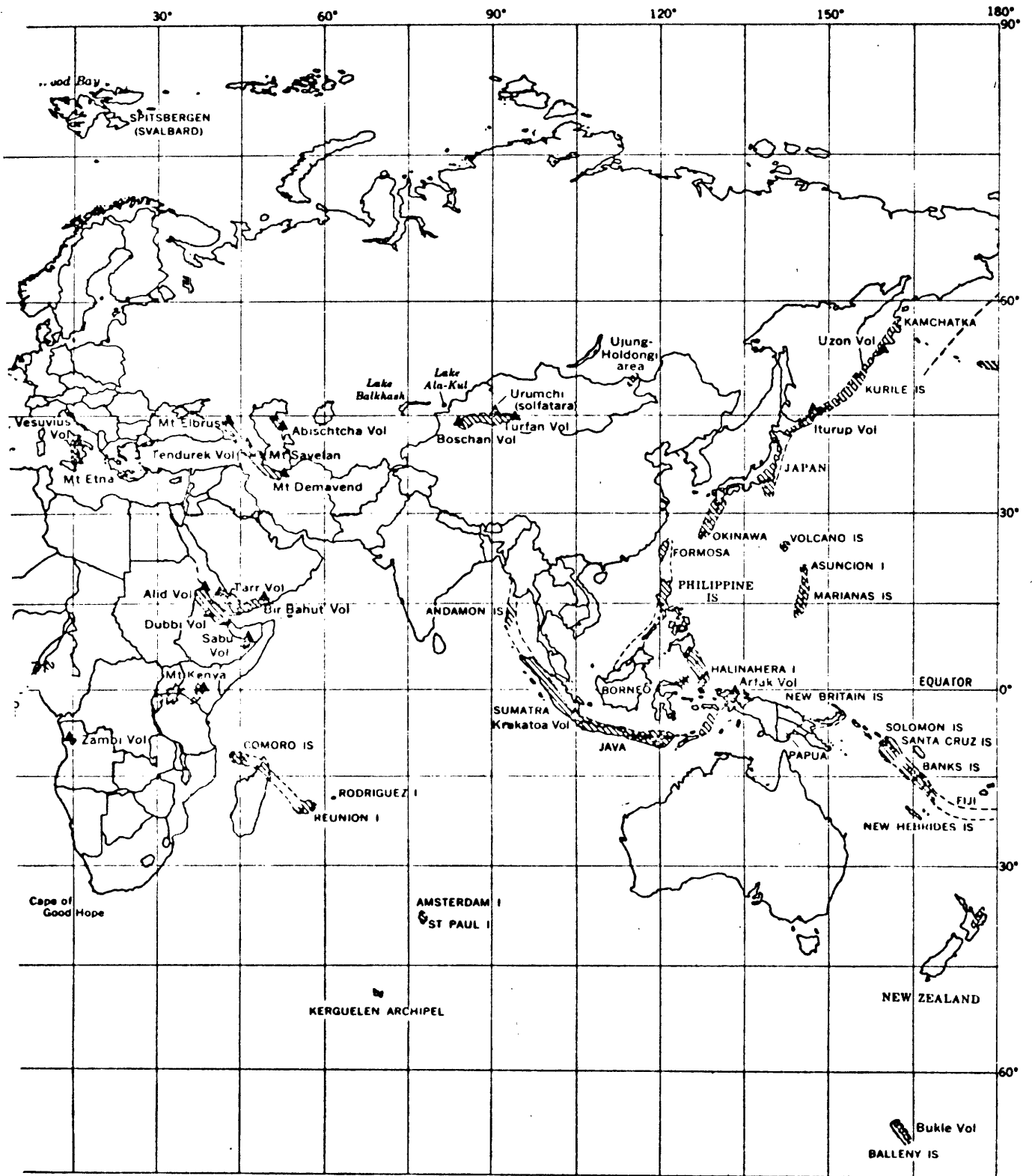
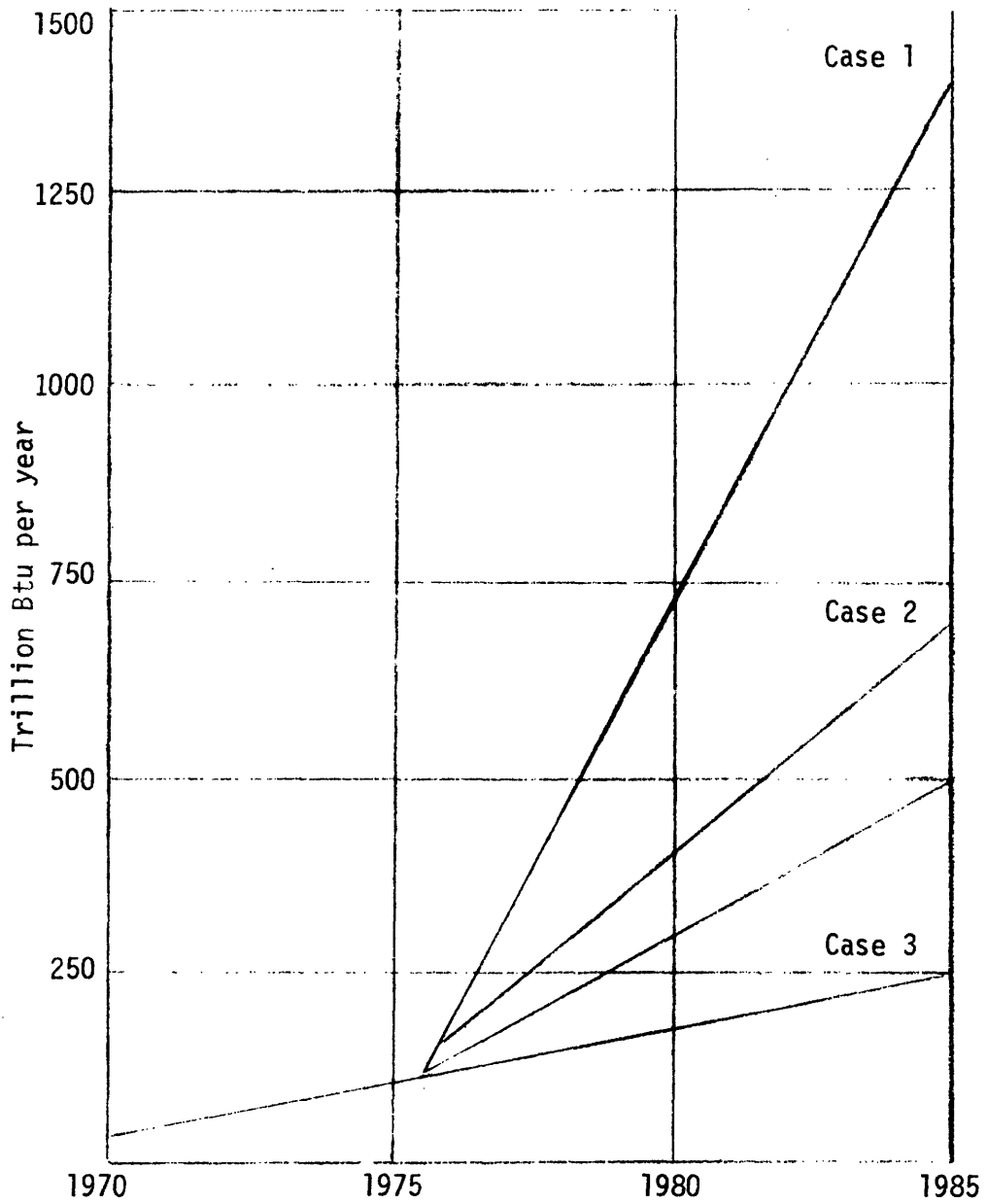

Figure 7



NOTE: In 1985, Case 1 represents 19,000 MWe of installed capacity; Case 2 - 9,000 MWe; Case 3 - 7,000 MWe
Case 4 - 3,500 MWe.

Figure 8
TOTAL U.S. ENERGY FROM GEOTHERMAL SOURCES

SOURCE: National Petroleum Council

We should encourage the exploration for and exploitation of geothermal energy in localities where it is close to the surface and of sufficiently high heat quality. This would permit release of scarce conventional fuels for use in non-geothermal areas. The primary uses to date have been for the generation of electricity and for space heating.

World-wide geothermal generating capacity (Figure 8) is about 900 MW, which is about 1/10 of 1 percent of world generating capacity from all modes. Most of this generating capacity is in three areas: Larderello in Italy, the Geysers in California, and Wairakei in New Zealand. There are also generating plants at Monte Amiata in Italy, Kawerau in New Zealand, Matsukawa and Otake in Japan, Pauzhetsky and Paratunka on the Kamchatka Peninsula in the USSR, Manafjall in Iceland, and Pathe in Mexico. Geothermal energy is used directly for space heating (Figure 9) in Iceland, the USSR, Hungary, New Zealand, and the United States.

There are several other, as yet minor uses (Figure 10), of geothermal heat. It is used in agriculture to heat greenhouses and soil. At Kawerau, New Zealand, geothermal heat is used in paper manufacture, and at Namafjall, Iceland for drying diatomite. At Rotorua in New Zealand, geothermal heat is used via a lithium bromide absorption unit to air condition hotels. Some geothermal fluids contain potentially valuable mineral by-products. Various schemes of desalination using geothermal heat have been proposed. And finally, there are the time-honored uses of geothermal waters for bathing and therapeutic purposes.

GEOHERMAL RESERVES

A concept as superficially simple as geothermal reserves has considerable room for ambiguity and uncertainty. Furthermore, when we consider our inadequate knowledge of the nature and distribution of geothermal resources, we can see that there is reason for considerable disagreement on the magnitude of our geothermal energy reserves.

Potential annual production from geothermal sources under varying conditions as studied by the National Petroleum Council, ranges from 250 trillion Btu to 1.4 quadrillion Btu in 1985. Table I lists the types of resources; Figure 5 indicates three possible situations based on:

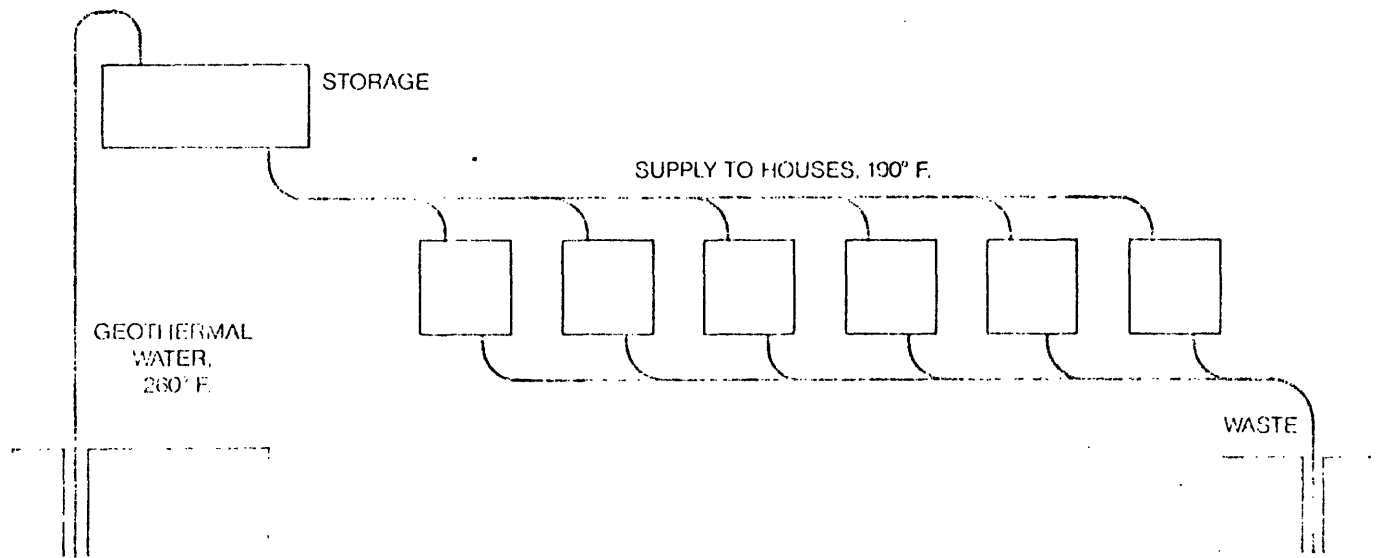

HEATING OF HOUSES and other buildings is done in a few places by a scheme such as the one shown here. Geothermal water

is pumped to a storage tank, from which it flows to the building. Such systems are in use or being developed in several countries.

Figure 9*

* from Barnea, Joseph, "Geothermal Power," Scientific American, Volume 226, Number 1, January, 1972, p. 76.

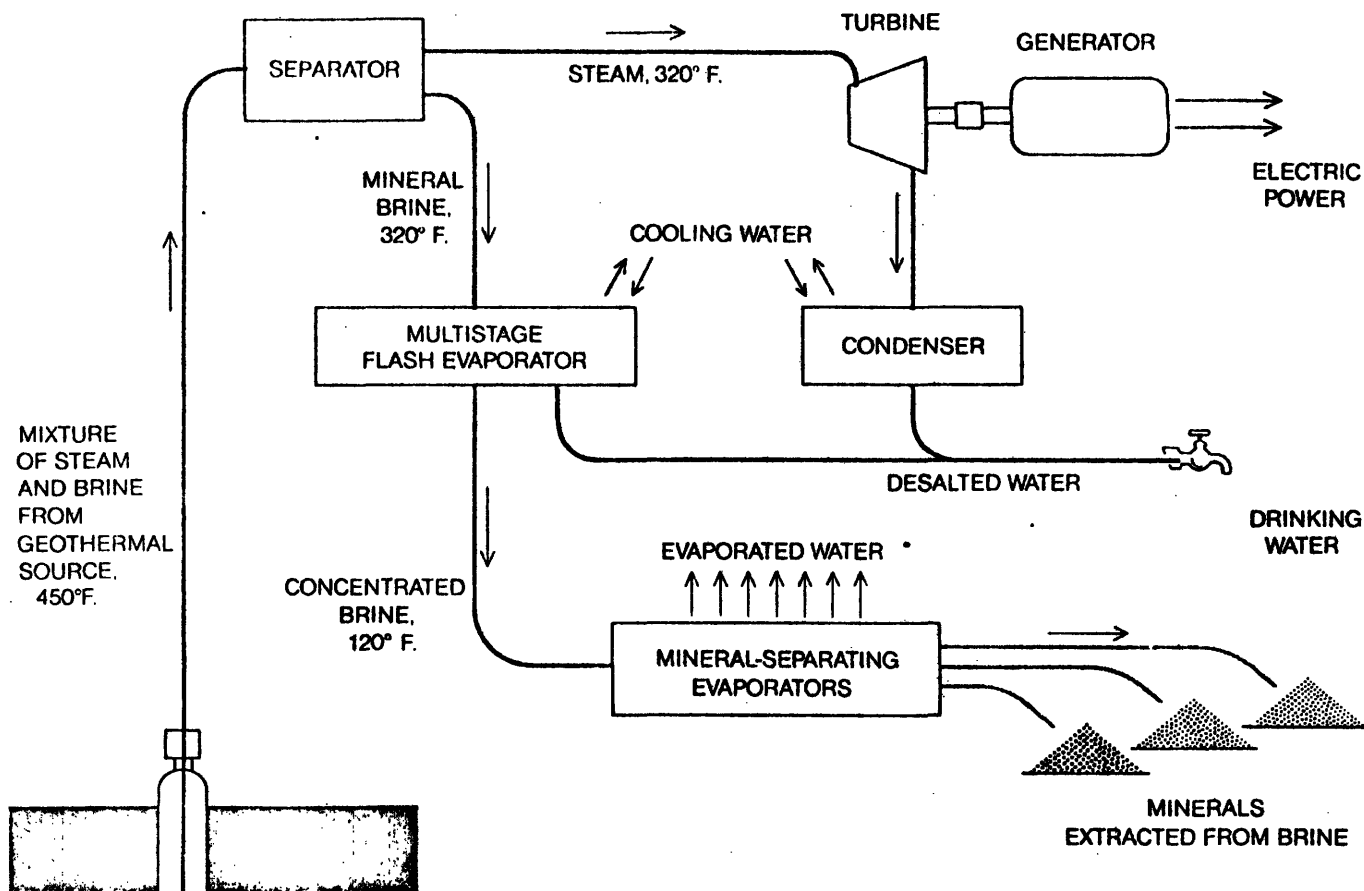

MULTIPURPOSE DEVELOPMENT based on geothermal energy is being designed by the UN and the government of Chile for a geothermal field recently discovered in Chile. In this case the geothermal source produces a mixture of steam and mineral-rich brine.

The steam and brine are separated, and the steam drives a turbine to produce electric power while the brine is put through an evaporator that concentrates it, thereby producing desalted water. The concentrated brine goes to a separator that extracts the minerals.

Figure 10*

* from Barnea, Joseph, "Geothermal Power," Scientific American, Volume 226, Number 1, January, 1972, p. 77.

TABLE I
 IN-SITU HEAT RESOURCES
 (quadrillion Btu)

<u>Geothermal Target</u>	<u>Reserve Target for 1985</u>	<u>Resource Base</u>
Localized hydrothermal systems, down to 2 mi. deep	5.6	560
Localized hydrothermal systems, down to 6 mi. deep	2.8	2,800
High-enthalpy waters, sedimentary basins	119	64,000
Magna chambers, within depths of a few miles	119	120,000-400,000
Low-enthalpy waters, sedimentary basins	635	640,000
Cratonic and platform areas, down to 6 mi.	2,000	20,000,000

*For comparison, heat of combustion of 1 bbl of oil is 5.8 million Btu. The recoverable amounts of heat are one to two orders of magnitude lower than the in-situ figures shown in this table.

Source: National Petroleum Council

- (a) Large areas, including Federal lands available for prospecting
- (b) A high success ratio in exploration and drilling (Case 1)
- (c) Good success ratio (Case 2)
- (d) Poor success ratio (Case 3)
- (e) Availability of technology for hot water systems

A U.S. Geological Survey report¹³ stated that over 1.83 million acres in ten Western states are within known geothermal areas, Table II. An additional 99 million acres are considered to have "prospective value" for geothermal steam. The USGS requirements for appreciable potential exploration are:

- (a) Temperatures above 150^o to 400^o F, depending on use and processing technology;
- (b) Under 10,000 feet depth for economic drilling;
- (c) Rock permeability allowing heat transfer agent to flow at steady, high rate; and
- (d) Sufficient water recharge.

ELECTRIC POWER GENERATION

There are two types of geothermal systems from which electrical energy is generated today. The first type is a vapor-dominated or "Dry Steam" system. Both steam and water are present at depth, with steam being volumetrically dominant in the hydraulically controlling phase. As water flows towards the well, it is vaporized. When the steam reaches the well head, it is superheated to become "dry" steam. The "dry" steam is piped directly into a turbine, where it drives an electric generator. Exhaust steam is condensed and the condensate discharged to the surface or reinjected into the ground. Examples of vapor dominated systems are the 356 MWe facility at Larderello, Italy and the 192 MWe combined generation capacity at the Geysers, California facility. At depth the temperatures in these reservoirs are 240^o C (464^o F) at pressures of about 530 lbs. per square inch. Unfortunately, these economically very favorable dry systems appear to be relatively rare.

Most geothermal systems appear to be of the hot-water type. The fluid at depth is a single phase - water - at temperatures well above surface boiling, owing to the hydrostatic pressure. Temperatures in hot water

TABLE II

KNOWN GEOTHERMAL RESOURCES AREAS

ALASKA

Pilgrim Springs
 Geyser Spring Basin and
 Okmok Caldera

CALIFORNIA

The Geysers
 Salton Sea
 Mono-Long Valley
 Calistoga
 Lake City
 Wendel-Amedee
 Coso Hot Springs
 Lassen
 Glass Mountain
 Sespe Hot Springs
 Heber
 Brawley
 Dunes
 Glamis

IDAHO

Yellowstone
 Frazier

MONTANA

Yellowstone

NEVADA

Beowawe
 Fly Ranch
 Leach Hot Springs

NEVADA (Cont.)

Steamboat Springs
 Brady Hot Springs
 Stillwater-Soda Lake
 Darrough Hot Springs
 Gerlach
 Moana Springs
 Double Hot Springs
 Wabuska
 Monte Neva
 Elko Hot Springs

NEW MEXICO

Baca Location No.1

OREGON

Breitenbush Hot Springs
 Crump Geyser
 Vale Hot Springs
 Mount Hood
 Lakeview
 Carey Hot Springs
 Klamath Falls

UTAH

Crater Springs
 Roosevelt

WASHINGTON

Mount St. Helens

reservoirs have been measured as high as 380°C (716°F) at Cerro Prieto in Baja, California. As the water passes up the well, it partly flashes to steam. Steam and water are separated at the surface, with only the steam passing through to the turbine generator. The major hot water system producing electricity today is Wairakei, New Zealand at 160MW capacity. Cerro Prieto at 75 MWe is scheduled to go on line this year.

When one looks at geothermal reserve figures, one must ask whether a given reserve figure represents heat in the ground, heat at the well head, heat at the turbine intake, or electricity generated. By no means can one get all the heat out of the ground. There will be in each field a temperature below which heat extraction becomes uneconomic. Furthermore, not all the heat above this temperature can be extracted, owing to local impermeability and non-optimum well spacing. Second, in a hot water system, for example Wairakei, half the heat brought up the well is in the water phase and cannot be run through the turbine. And thirdly, because of the relatively low pressures and temperatures of geothermal steam, electric power plant efficiencies are about 15%, considerably lower than modern fossil fuel or nuclear plants.

Present day geothermal plants that use steam directly (single fluid conversion) in the turbine require a reservoir temperature of at least 180°C . At lower temperatures, the steam flashed is quantitatively insufficient. There are several technological breakthroughs that are being actively pursued today.

The first involves a potential method for generating electricity from a low-temperature hot-water system. The proposed system doesn't involve flashing and theoretically can use waters down to 100°C and lower. Water is pumped to the surface under pressure so that it does not vaporize, and its heat is exchanged with a low-boiling point fluid such as iso-butane. The iso-butane vapor drives a turbine, is condensed and recirculated in a continuous loop. A variant of this scheme is to be tested this year by San Diego Gas and Electric in the Imperial Valley of California. The Russians have a similar pilot plant using "Freon" at Paratunka in Kamchatka, where the intake water is only 90°C . The results are not known.

Another technological breakthrough may lie in the exploitation of what are called hot dry rock systems; that is, geothermal systems that are hot but lack natural permeability and naturally circulating fluids. There are two groups of investigators that are attempting to develop such systems. One group, involving Battelle Northwest, Roger Engineering, and Southern Methodist University, plans to put a deep drill hole at the heat flow anomaly discovered at Marysville, Montana. Another group, at Los Alamos Scientific Laboratories in New Mexico, is investigating an area of high heat flow just west of the Valles Caldera.

The basic idea is to drill a hole to a depth of about 4 km. and to fracture the earth about the end of the hole, up to 4 km. in radius. A second hole is drilled to intersect this region. Then cold water is pumped down the first hole, is heated, and rises to the surface with a temperature of 250° C and 80 kg/cm², where it flashes to steam (see Figure 11).

Fracturing of the hot rock at depth can be accomplished with cold water, dynamite or nuclear devices.

In July, 1974, a U.S. interagency task force reported that geothermal electric-power generating plants could be producing 30,000 megawatts by 1985 and 100,000 megawatts by 1990. This task force recommended that the National Geothermal Energy Research Program of the National Science Foundation be "accelerated on an orderly basis" so that a million barrels a day of oil could be saved by 1990 and 3-6 million barrels per day by the year 2000.

LAND USE (The Geysers)

Table III gives estimates of land needed to support a 1000 megawatt plant. Surprisingly, coal and geothermal developments occupy about the same areas. However, the coal plant is essentially a strip mine. The geothermal plant represents far less intensive use. At Larderello, Italy, it is possible to grow grapes among the geothermal fields to take advantage of the increased moisture content of the air. Cattle grazing is being experimented with at The Geysers. The question of desirability of significant human habitation close by is more difficult to deal with. It is also clear that if land use is the prime consideration, then the nuclear power plant deserves high marks.

TABLE III
LAND USE ESTIMATES

1000 Megawatts of electrical output 30 year estimated life time
in square miles

	Fuel Recovery	Power Plant
Coal ¹	10 - 40	3/4
Geothermal ²	10 - 15	Included
Nuclear ³	1/4 - 1/2	1/2

¹Four Corners Plant, New Mexico, Coal Strip Mine

²The Geysers, verbal estimates from Union Oil Company based on vapor type source.

³Converse Uranium Mine, Environmental Impact Statement, Wyoming Proposed Mendocino Power Plant site (two units totalling 2260 megawatts on one site)

The above estimates of necessary land imply decisions about well spacing and allowances for possible additional drilling to sustain production for 30 years. These are based on company classified information of which we have no knowledge.

LIFE TIME OF THE FIELDS

Most of the knowledge in this area is company classified; however, we do know that the fields at Larderello, Italy, have been in operation for nearly 70 years. Perhaps one really finds out by trying. It is important to realize that a vapor dominated system gives little warning of impending depletion. There is more heat than water and the steam pressure remains high until the very end.

It may be possible to inject more water to rejuvenate the field. Right now only about 20% of the condensed steam is reinjected. The rest is evaporated to cool the outlet of the turbines to improve the thermodynamic efficiency.

LAND SUBSIDENCE AND EARTHQUAKES

These are not big problems around the Geysers. The pressure remains constant until the field is depleted and the rocks are not subject to new stresses until then. In a hot water system, removing water has caused land subsidence (Wairakei in New Zealand). There have been noticeable increases in microearthquakes around The Geysers and the meaning of this is not clear.

COOLING PROBLEMS

Nature provides the geothermal steam at 179° C compared with about 500° C steam used in fossil fuel plants. Thus, the thermodynamic efficiency of the geothermal plant is less - 15% being typical. To achieve even this efficiency it is necessary to cool the exhaust of the turbines to reduce the back pressure to almost a vacuum. This requires cooling towers. Fortunately, there is enough water from the steam to supply the towers. The potential for atmospheric modification is present and has not been studied in detail; however, the plants are distributed over a large area and locating the cooling towers in places where there are stronger winds should aid in the dispersion of the heated air.

POTENTIAL AIR QUALITY DEGRADATION

The sulfur as H_2S is perhaps the most significant problem health-wise and this is reflected in very stringent air quality standards. Table IV reveals that the Geysers' geothermal steam is worse than an oil-gas fired plant. The Geysers output is nearly pure steam with only 0.55% H_2S . Unfortunately, the thermodynamics are poor and we must use 18.2 lbs. of steam to produce a kilowatt hour, or about 0.1 lb. of sulfur per kilowatt hour.

At an oil fired plant, approximately 0.5 - 0.6 lbs. of oil will do the same job. Thus, the geothermal steam is equivalent to 1.8 - 2.3% sulfur content oil - Table IV. This is high sulfur fuel by present standards.

The potential for solving this problem is somewhat better than at a coal or oil fired plant. First, the non-condensable gases are already collected separately. Thus they can be dealt with. The portion of the gas evaporating from the cooling towers is harder to deal with, though. Secondly, the reinjection well provides a ready disposal site, back into the earth. Reinjection was initially begun to prevent the slight amount of boron from contaminating the surface waters. At present time there appears little risk of substantial surface water contamination.

EARLY ESTIMATES

The residence time of the sulfur compounds in the air was considered to be less than a week (The Sulfur Cycle, Science, 175, 587 (1972)). Recent studies indicate that the time is proportional to many factors and is being reviewed and studied. Thus, while the problem is serious and must be dealt with, one should maintain some perspective. The problem most directly affects people living near the geothermal areas and these areas, to date, are not thickly settled.

NOISE

Measurements of noise levels as they existed at The Geysers on March 11, 1973 are given in Table V. Conclusions depend very much on the reference frame of the observer. They are not much above those found in relatively quiet residential neighborhoods. It would seem that the noise of routine

TABLE IV
COMPARATIVE WASTE PRODUCTS

In tons per day for 1000 Megawatts electrical output

Substance	Oil & Gas Plant ¹	Geysers ²	Nuclear ³
H ₂ O	8,400	217,000	---
CO ₂	16,400	1,700	---
Organics	.23	260	---
Sulfur Compounds	1.7	110	---
Nitrogen Oxides	19.2	---	---
Radioactive Wastes	---	---	0.26

¹Data are for PG&E Pittsburg Plant (1971) taken from Air Pollution and the San Francisco Bay Area, Seventh Edition, Bay Area Air Pollution Control District, San Francisco, CA, 1972. This plant burned a combination of oil and natural gas during the period reported on.

²Data of geothermal steam composition are from Finney, J.P., The Geysers Geothermal Power Plant. Chem. Engineering News 68, 83 (1972). The organics are methane and ammonia. The sulfur is as hydrogen sulfide.

³Data from Preliminary Safety Analysis and Environmental Impact Statement for PG & E proposed nuclear power plant: Mendocino Units 1 and 2. Tonnage is for total of shipments from the site averaged over a year and scaled to 1000 megawatts. Breakdown: 0.07 tons of spent fuel and 0.19 tons of packaged wastes.

TABLE V

NOISE LEVELS AROUND THE GEYSERS

Measurements on 3 - 11 - 73

<u>Location of Measurement:</u>	<u>Level in decibels "A" weighting</u>
Outside Units 5 & 6 - inside protective fence	73
Geyser Resort approximately .5 mile from field	63
1.5 miles across valley	53

For comparison the following are offered:

Valley not associated with geysers approximately 7 miles distant	43
Near Stream in above valley	63
Berkeley, east side of campus, evening of 3-2-73	60
Vallejo, residential area, early evening of 3-2-73	58
Home, 5850 Henning Road ¹⁰ Sebastopol, evening of 3-11-73	43

¹⁰Dunning, Sonoma State College, Sonoma California, private conversation.

power generation can be reduced to almost arbitrarily low levels.

LONG RANGE QUESTIONS

These are largely concerned with effects too subtle to show up now, because of the small scale of activities or the long time scale over which they act. Among them are field life time, earthquake possibilities, subtle effects on the water in tables, and possible meteorological effects. Many of these questions will be best resolved by careful monitoring of the effects in question while continuing geothermal development. Constraints, as suggested by the NPC, are listed in Table VI.

Geothermal Target	Current Constraints	Subsequent Constraints	Outer Contingency
Localized hydrothermal systems down to 2 mi. deep	Leasing, exploration, economics	Small resource base	Air and water pollution
Localized hydrothermal systems down to 6 mi. deep	Economics	Leasing, exploration	Air and water pollution
High-enthalpy water, sedimentary basins	Exploration, deep drilling	Economics	Brine disposal and utilization
Magma chambers within a depth of a few miles	Exploration, R&D Magmas	Economics	Unknown
Low-enthalpy waters, sedimentary basins	R&D power generation	Exploration, economics	
Cratonic and platform areas, down to 6 mi.	R&D Plowshare	Economics	Radioactive pollution

Source: National Petroleum Council

TABLE VI
CONSTRAINTS TO GEOTHERMAL RESOURCE DEVELOPMENT

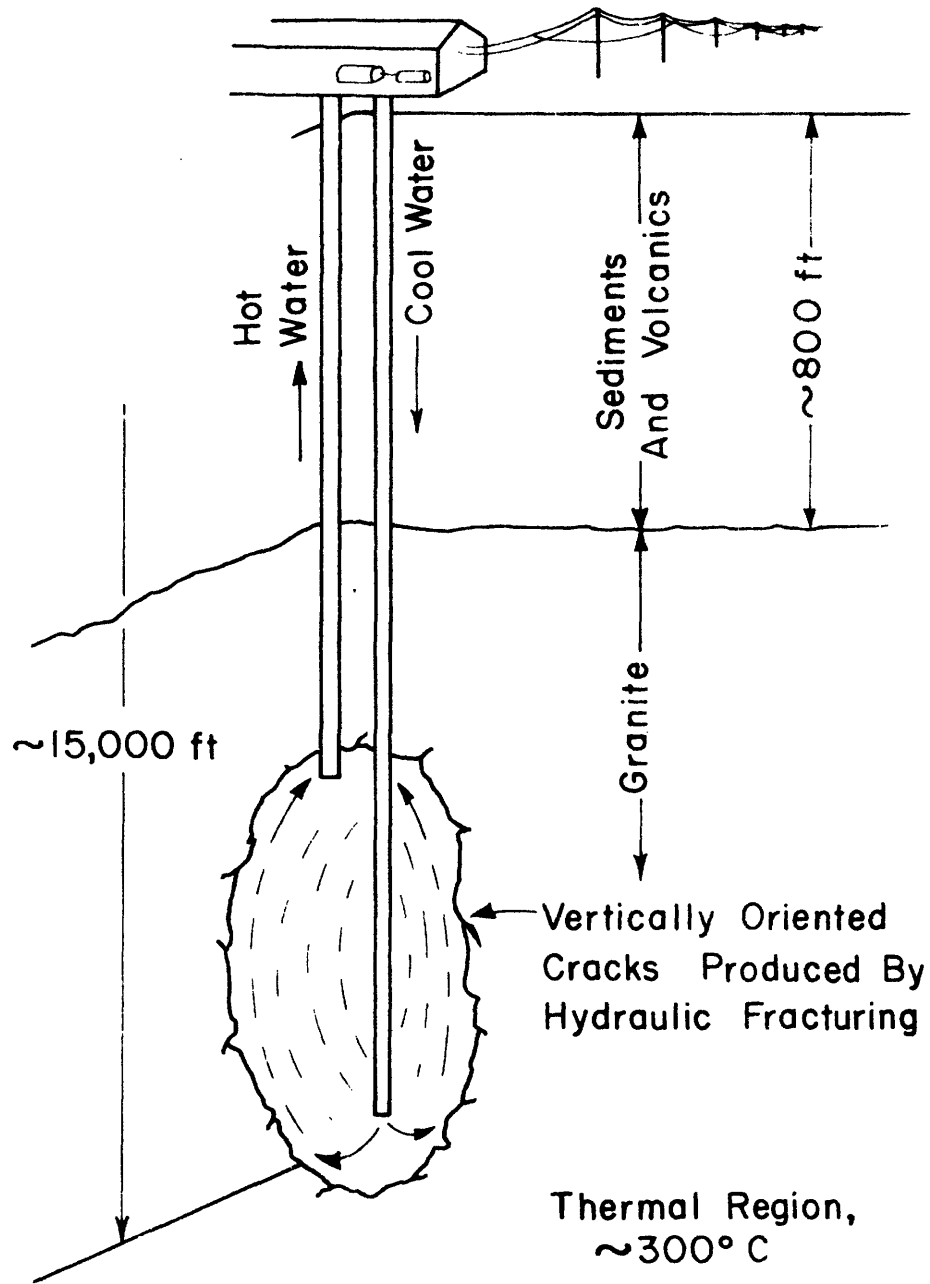

Figure 11: Dry Rock Geothermal Energy System by Hydraulic Fracturing

Source: AEC, 1973 See reference 15.

BIBLIOGRAPHY

- 1) Muffler, L.J.P., "Geothermal Resources and their Utilization," Heat Flow Symposium Geological Society of America, Portland, Oregon, March 1973.
- 2) White, Donald E., "Characteristics of Geothermal Resources and Problems of Utilization," in Kruger and Otte (eds.), 1973, Geothermal Energy: Resources Production, Stimulation: Stanford University Press, June 1973.
- 3) Senate Committee on Interior and Insular Affairs, "Geothermal Energy Resources and Research," serial 92-31, June 1972.
- 4) Hickel, Walter J., Geothermal Energy, Final Report of the Geothermal Resources Research Conference, Battelle Seattle Research Center, Seattle, Washington, September 18-20, 1972; sponsored by the National Science Foundation (RANN).
- 5) Muffler, L.J.P., "Geothermal Research in the U.S. Geological Survey. Talk presented at the Geothermal Symposium held at the 42nd Annual International Meeting of the Society of Exploration Geophysicists, Anaheim, California, November 30, 1972.
- 6) Muffler, L.J.P., "United States Mineral Resources: Geothermal Resources," U.S. Geological Survey Prof. Paper 820.
- 7) White, Donald E., "Geothermal Energy," Geological Survey Circular 519, First Printing, Washington, 1965.
- 8) Hamilton, R.M., 77,11,2081, Journal of Geophysical Research.
- 9) "The Sulfur Cycle," Science 175, 587 (1972).
- 10) Dunning, John, "Federal Power Commission National Power Survey, 1973."
- 11) Bullard, E., 1973 "Geothermal Energy, UNESCO, Paris, France.
- 12) Lackenbruck, H.H. (1970) "Crystal Temperature and Heat Production," L. Geophys. Res. Vol. 75, pp. 3291-3300.
- 13) U.S. Geological Survey, Circular 647 "Classification of Public Lands Valuable for Geothermal Steam and Associated Geothermal Resources," Reston, Virginia 22092.
- 14) Muffler, L.J.P., and White, D.E. "Geothermal Energy," The Science Teacher 39(3), 1972, p. 40.
- 15) Atomic Energy Commission (1973). "The Nation's Energy Future; a Report to Richard M. Nixon, President of the United States," submitted by Dixie Lee Ray, Chairman, U.S. Government Printing Office.



James W. Meyer
December 1, 1974

Monograph No. 5
MIT Energy Laboratory
HYDROELECTRIC POWER

In mid-1974 the total conventional hydroelectric power developed in the contiguous United States averaged 260 billion kilowatt-hours annually from a capacity of 55,000 megawatts. Nearly one-half of this capacity and more than one-half of the generation is in the pacific states, Washington, Oregon and California.

Nearly 7,000 megawatts of capacity are now under development, 90% of which is in the pacific states.

A review of potential sites for hydroelectric developments with capacities of 100 megawatts or more, or additions of 25 megawatts or more found 44 new sites and 26 potential additions that might be completed through 1983. Of this total of 70 sites, only one is in New England: Dickey-Lincoln School. The expected installed capacity of Dickey-Lincoln School would be 830 megawatts with an average annual generation of just over one million megawatt hours. Friends of the St. John aver that "The Dickey-Lincoln Project will never solve the energy crisis because the project is not big enough. Nor can it be made bigger or be operated for a longer period daily, because the water supply is too limited for large or larger operation. New units, such as Boston Edison's Mystic No. 7 or Pilgrim No. 1, each produce about four times as much as Dickey-Lincoln would. Thus, the dams cannot take the place of new nuclear or fossil-fueled power plants."

Forty existing hydro facilities could be expanded to add 12,700 megawatts of capacity. Most of these facilities use all of the available water now so that expanding capacity could only be done at the cost of reduced operating time.

The number of favorable sites available for conventional development is limited. There are pros and cons for the development of the remaining potential such as the production of power without consuming fuel versus the replacement of flowing streams with reservoirs and changing the character of a scenic valley. It might be mentioned that because of their

ability to pick up load and change the rate of output quickly, hydroelectric plants are particularly suited for providing peak and reserve capacity for utility systems.

Pumped storage is closely related to hydro power in that a reservoir at a height to provide a head is kept full using excess capacity from fossil fueled or nuclear plants during off peak periods so that hydrogeneration from this storage could be used to meet peak load demands.

Pumped storage also presents controversial issues. Consolidated Edison Company of New York has been involved in a decade of proceedings and litigation over its proposed 2000 megawatt hydroelectric facility in the Hudson River highlands, the (Storm King) "Cornwall Project."

As of May 1974, the total developed pumped storage capacity in the contiguous United States amounts to a little over 8,000 megawatts.

There is only one sizeable tidal power project in the world -- the 240-megawatt Rance project in France. Passamaquoddy Bay is the most favorable site in the United States and Canada. Studies of the project in the 1960s indicated that the contemplated 500 megawatt plant was not economically justified. Even if increasing costs of power from alternative sources and improvements in the techniques of construction result in economic feasibility, substantial environmental issues would have to be resolved such as the flooding of valleys, the relocation of populations and wildlife, alteration of ground water tables and changes to drainage patterns of stream and river flows. Tidal projects affect shipping, fishing, and coastal ecology and pumped storage has the problem of a widely varying waterline with the ebb and flow of electric power demand. Detractors claim that it lessens the pumped storage pond's value as a recreational site, and at low water is an eyesore.

BIBLIOGRAPHY

1. Staff Report on the Role of Hydroelectric Developments in the Nation's Power Supply, Federal Power Commission, Bureau of Power, May 1974.
2. Luther J. Carter, "Con Edison: Endless Storm King Dispute Adds to its Troubles", Science, Volume 184, pp. 1353-1358, 28 June 1974.

Monograph No. 6
MIT Energy Laboratories
OIL SHALE

For years the hundreds of billions of barrels of oil equivalent locked in several basins of the Rocky Mountain's Green River Formation in the tri-state area of Utah, Wyoming, and Colorado has looked like an unexploited (perhaps unexploitable) bonanza of fossil fuel. Oil shale is neither oil nor shale, strictly speaking, the "oil" being an organic polymer called kerogen, the "shale" a marlstone-type inorganic component. Cowboys used to burn oil shale in their campfires and some hapless early settlers of the region attempted, with disastrous results, to build fireplaces with the attractive grey-tan stone.

In the Piceance Creek Basin, Colorado, there are an estimated 160-billion barrels of shale reserves near the surface; of which 34-billion barrels are considered recoverable.

Most processes for recovering oil from oil shale involve heating to decompose the kerogen to volatile oil and gas followed by condensation and recovery of the vapors. Most oil shale in the western formations contain at least 25 gallons of oil per ton of shale.

The three major components of shale oil production are mining, crushing, and retorting. The Oil Shale Corporation (TOSCO) has operated a 1,000-ton per day semiworks plant near Grand Valley, Colorado, to develop the TOSCO II process. Commercial design is now underway. Yields of the TOSCO II process with shale from the Piceance Basin were 33 gallons per ton of shale. Shale oil differs from petroleum in that it contains a higher proportion of nitrogen and oxygen.

The U.S. Bureau of Mines' Laramie, Wyoming Research Center has experimented with in situ extraction of oil from shale. In the experiment shale was fractured with nitroglycerin, ignited and allowed to burn six weeks, resulting in recovery of 190 barrels of shale oil. Gerald Dinneen, Director of Research, believes oil shale retorting and in situ extraction may be the most economical. Experiments thus far have been on far too small a scale to permit meaningful extrapolation of economic factors to large scale

commercial production.

Garrett Research and Development Co., research arm of Occidental Petroleum Corporation, has reported a test project for in situ recovery of shale oil on a 4,000-acre tract on the southern edge of the Piceance Basin. The process involves some mining, large-scale rock breakage, and retorting in place. Total recovery of oil has not been disclosed but consistent pumping of 25-30 barrels per day has been mentioned. The pilot plant is on a very small scale but the Garrett firm believes commercial scale is feasible within 3 years with intensive development effort. The problems of expanding the scale of the plant have to be fully explored and when they are uncovered and solved, 3 years is likely to be quite optimistic if a 40,000 barrels per day plant is to become operational. The technique does have promise of producing shale oil at lower cost than mining and surface processing, and it does require less water. It is the only one of several in situ techniques for which much success has been claimed.

Morton M. Winston, President, TOSCO expects the completion of the first commercial oil shale complex in the spring of next year. The plant will produce 46,000 barrels per day of refined products (equivalent to 51,000 barrels of crude). Winston estimated that 600-billion barrels of shale oil were recoverable from the Green River Formation. He also stated that first generation commercial plant complexes can be commenced as early as 1979.

Fred L. Hartley, Union Oil Company, has reported a process that will recover 82% of the thermal energy in the shale in the form of syncrude or high BTU gas. The three main problems facing oil shale development are:

1. Political
2. Financial
3. Water

Water availability could limit shale oil production to 1-2-million barrels per day.

Hartley reported estimated costs for a 100,000 barrel per day shale oil complex for the years, 1970, 1974, and 1980, and the per barrel price of oil based on a 15% return on investment:

1970	\$ 525-million	\$ 5.00/bbl
1974	\$ 790-million	\$ 7.00/bbl
1980	\$1400-million	\$11.50/bbl

In face of such huge investments to produce a product equivalent to that produced elsewhere in the world for as little as 25¢ - 75¢ per barrel, there is increasing scepticism about the viability of extensive production of oil from shale. This scepticism is expressed even by those companies that have spent hundreds of millions of dollars for their leases. Moreover, Montana Governor Thomas L. Judge warns that land and water supplies cannot support both an expanded agricultural economy and a full-scale energy development. According to an environmental impact statement published by the Department of the Interior in August, 1973, a 1-million-barrel-a-day operation would require between 107,000 and 170,000 acre feet of water a year, and municipal development associated with industrialization of the area would require another 14,000 - 19,000 acre feet of water. The impact statement suggests that about 340,000 acre feet of water is potentially available for oil shale operations. The chief consumers of water in oil shale production are spent shale disposal and shale oil upgrading so that it can be transported by pipeline.

The above water problems make in situ processing appear attractive; however, one indication of the fact that most of the oil industry is not willing to venture into this unknown area is that of the six tracts of land put up for lease by the Federal government, the two that were suitable for in situ methods failed even to attract a single bid.

An AEC study recommended that the Federal government assist industry to establish a plant capable of producing 30,000 to 50,000 barrels of oil a day to demonstrate the technology of in situ processing on a commercial scale. If construction were to begin in 1975, the demonstration plant would be in operation in 1977, and if proven successful, an industry production capability of about 1.8 million barrels per day could be achieved by 1985.

BIBLIOGRAPHY

1. Mark T. Atwood, "The Production of Shale Oil", p. 617, CHEMTECH October 1973.
2. Colin Norman, "Huge Resources Needed to Exploit Shale Oil", Nature, Volume 259, June 21, 1974.



James W. Meyer
December 1, 1974
Amended June, 1975
William J. Jones

Monograph No. 7

MIT Energy Laboratory

SOLID WASTE FOR THE GENERATION OF ELECTRIC POWER

Solid waste is an ubiquitous, self-renewing energy source concentrated in our population centers. Americans produce between 200 and 300 million tons of solid waste a year, around a ton for every man, woman and child in the country, enough to cover the entire state of New Hampshire with a layer six inches deep. Estimated on the basis of population, New Hampshire accounts for 700,000 tons/year. We dispose of 90% of our waste in land fills, 8% in incinerators, and 2% by other means. Urban solid waste consists typically of 40-45% paper, 20-25% organic materials, and the remainder, 30-40% metals and glass. Such solid waste has an energy content of from 4,500 to 5,500 Btus per pound.

Most major metropolitan areas are running out of places to put it all. New York City for example, expects to overflow its available dumping grounds in the next several years. More than twenty cities are looking for other solutions.

The Union Electric Company in St. Louis has been processing and firing a mix of solid waste with coal to produce 125 MWe electricity. The proportion of solid waste is 15-20% of the heating value of coal or 400 to 600 tons per day. The heating value of coal averages 11,500 Btu/lb, the heating value of the waste 4,600 Btu/lb. This experimental prototype has been in operation since mid-1972. A new \$70-million plant is being built which will generate about 6% of its power from solid waste and will draw trash from St. Louis and six adjoining Missouri and Illinois counties. The project is scheduled to be in operation by mid-1977 and could save Union Electric up to \$10-million a year in fuel costs. Annual operating costs of the facility are expected to be \$11-million.

Garrett Research and Development Company, La Verne, California has developed a solid waste pyrolysis process which produces from each ton of refuse almost 1 barrel of oil, 140 pounds of ferrous metals, 120 pounds of glass, 160 pounds of char, and varying amounts of medium energy gas (400 to 500 Btu per scf). A 200-ton-a-day demonstration plant handles all the solid wastes produced by Escondido and San Marcos, California. Oil from the plant will be sold to the San Diego Gas and Electric Company. Garrett

estimated in 1972 that a full-scale, 200-ton-per-day plant to process wastes from a city of 500,000 would cost about \$12-million.

Monsanto Enviro-Chem Systems, St. Louis, Missouri, has operated a 35-ton-per-day pyrolysis plant which served as a prototype for a 1000-tons-per-day plant for the City of Baltimore (population 900,000). Two waste heat boilers will produce steam for Baltimore Gas and Electric Company; 200,000 pounds per hour of steam for each 1000 ton-per-day boiler. The project cost is just under \$15-million and anticipated operating costs are roughly \$6-per-ton.

The Nashville Thermal Transfer Corporation, Nashville, Tennessee (population 500,000) is operating a district heating and cooling system on solid waste. Two units, each able to handle 860 tons-per-day are being installed in the \$16.5-million total system which includes distribution. Presently 200-tons-per-day are being burned to produce 200,000 pounds of steam per hour. Both steam and chilled water are distributed in a four-pipe system.

The City of Seattle (population over 500,000) has made an exhaustive study of the disposal and/or utilization of 550,000 tons-per-year of solid waste. As a result of the study, a recommendation was made that Seattle's solid waste be converted to methanol at an estimated rate of about 40-million gallons a year. It was suggested that methanol would be an ideal fuel for a gas turbine powered electrical plant. Methanol is also a good fuel for use in fuel cells.

Columbia University workers have studied the problem of the economic utilization of municipal refuse for the City of New York in a National Science Foundation (RANN) sponsored program. It was concluded that, for New York City, the Union Carbide Oxygen Refuse Converter would be the best choice. The Union Carbide Corporation is currently proceeding with plans to erect a 200-ton-per-day demonstration in Charleston, West Virginia to be operated with mixed municipal refuse supplied by that municipality. The disposal of de-watered sewage sludge by pyrolysis can also be evaluated.

Parson and Whittemore Inc. is to build a \$44.6-million, 2000-tons-per-day recycling plant for Hempstead, L.I., a city of 800,000 people. Long Island Lighting Company will buy combustibles to produce 225 megawatts of

electricity.

Characteristics of these planned and operating facilities is that they are designed for populations of 500,000 or more in a reasonably compact area. This facilitates the collection and eases the transportation costs of solid waste. Energy costs of collection and transportation rise quickly for dispersed populations. Many of these urban centers have populations equal to or greater than the entire State of New Hampshire.

If we base our estimates on population, the Cities of Portsmouth and Dover produce about 50,000 tons of solid waste a year. About 10,000 BTUs are required to produce a kilowatthour of electric energy in a conventional steam plant. If the solid waste used has an average energy content of 5,000 BTUs per pound or 10-million BTUs per ton, one megawatt hour of electric energy can be produced from each ton of solid waste. If it were possible to collect, transport and produce all the solid waste from Portsmouth and Dover, for example, we could produce 50,000 megawatt hours per year. It would be necessary that the plant operate all of the time and it would be possible to store and use waste independently of day-to-day variations in amount and kinds of waste.

A 1200 megawatt electric generating plant, operating only half the time, produces over 5 million megawatt hours a year. To produce an equivalent amount of electric energy from solid waste, we would have to derive it from an aggregate population of 5 million people---about the population of the State of Massachusetts. From a consideration of energy, these conversion methods are severely restricted by the limited amount of solid wastes available and transportation costs and problems from over the entire region to the central bulk generating plant.

For urban regions and smaller sized urban centers, waste must be considered more as sources of supplementary fuels than alternative total resources.

7-4
REFERENCES

- Wisely, Horner & Shifrin, Inc., "City of St. Louis - Union Electric Co. Energy Recovery Process Solid Waste as a Boiler Fuel", The US/Japan Energy Conservation Seminar, San Antonio, Texas, February 1974.
- Hammond, Allen L., William D. Metz, and Thomas H. Maugh II, "Energy and the Future", American Association for the Advancement of Science, Washington, D.C., 1973.
- Thomas H. Maugh II, "Fuel from Wastes: A Minor Energy Source", Science, Volume 178, 10 November 1972.
- Helmut W. Shulz, "A Pollution Free System for the Economic Utilization of Municipal Refuse for the City of New York", Columbia University in the City of New York, March 1, 1973.
- Robert G. Sheehan, "Methanol from Solid Waste ... Its Local and National Significance", City of Seattle, July 1974.
- John Papamarcos, "Power from Solid Waste", Power Engineering, Volume 78, September 1974.
- James G. Albert, Hawey Alter, and Jo Frank Bernheisel, "The Economics of Resource Recovery from Municipal Solid Waste", Science, Volume 183, 15 March 1974.

Monograph No. 8

MIT Energy Laboratory

ENERGY FROM FORESTS AND PLANTATIONS, AND OTHER BIOMASS

The first source of "artificial" energy was wood. It furnished heat and light and, indirectly, power. Trees, bushes, straw and farm by-products still provide fuel in a sizeable portion of the world. Its use is mostly limited to single family units.

Wood as a Fuel for Electric Power

Much to the surprise of many people, New England has increasing numbers of acres of its land area in forests. A century ago, Massachusetts was two-thirds cleared and one-third forest -- today the reverse is true. Seedlings quickly spring up in abandoned clearings which in time become dense second growth timber stands. The Forest Resource Report Number 20, October 1973 gave the following figures for wooded land in the states of New England:

	Acres of Land Area (in thousands)	Forested Area (in thousands)
Maine	19,797	17,748
New Hampshire	5,781	5,131
Vermont	5,935	4,391
Massachusetts	5,013	3,520
Rhode Island	671	433
Connecticut	3,116	2,186

Source: U.S. Department of Agriculture, Forest Service,
Forest Resource Report Number 20, October 1973.

The Forest Survey Project of the Northeastern Forest Experiment Station of the U.S.D.A. Forest Service has estimated the volume of hardwoods grown each year that is not used for other forest products which could be consumed in each state as firewood without depleting the forests, that is,

growth and harvesting would be equal. These estimates are shown in the following table:

	Estimated cords of hardwood available for fuelwood (in thousands)	Tons (in thousands)
Maine	338	845
New Hampshire	727	1,817
Vermont	215	537
Massachusetts	409	1,022
Rhode Island	65	162
Connecticut	442	1,105

If weed trees, culls and tops and limbs of trees harvested for other purposes are included, the estimate about doubles for each state. The heat value of wood varies from about 27 million Btu/cord for the best dry hardwood to a little over 10 million Btu/cord for the poorer green wood. Thus the best wood has a heat value equivalent per cord to just under 200 gallons of fuel oil. If all the available fuelwood in New Hampshire were to be used under boilers for generating electric power, about 15 trillion Btu/year would be produced (assuming 20 million Btu/cord). Further assuming a heat rate for the power generating plant of 10,000 Btu/kWh, 1.5 million megawatt-hours per year would be produced. This is equivalent to a 200 megawatt station operated year round. Clearly the task of cutting, chipping and transporting this much wood-fuel from all over the state of New Hampshire would be a prodigious task.

Forests are like any other agricultural product. The soil must furnish nutrients in order for the trees to grow. In an undisturbed forest, leaves and dead trees remain on the ground and by their decay return the nutrients to the soil. Forest harvesting will require that the nutrients, lost by removal of the wood to a generating plant, would have to be made up by commercial fertilizers, which currently require petrochemicals.

Szego and Hemp⁽¹⁾ have made an extensive study of the potential for energy forests and fuel plantations and estimated that 400 megawatts of electric power could be continuously supplied from a land area of 400

square miles managed and harvested in a manner similar to southern pulp mill plantations. In their 1973 paper, they estimated the capital costs for the plantation and power station at about \$400/kW. A portion is attached as Appendix I. Sidney Katell, referee of Szego and Kemp's paper independently estimated the cost of southern pine wood fuel as being equivalent to \$25 per ton coal. He based this estimate on the following assumptions for a forest in a southern state (e.g. Georgia):

1. Production: 5 tons per acre-year
2. Land cost: \$50 per acre
3. Harvesting cost: \$9 per ton
4. Interest plus taxes: 8.6% of land cost.

These assumptions are admittedly optimistic.

The Green Mountain Power Corporation of Burlington, Vermont is considering the establishment of a small 4000 kilowatt wood-burning electric generating facility as a pilot project to test the feasibility of procuring wood chips as a fuel. Satisfactory results could lead to the construction of a larger wood-fired generation facility. The following sets forth the basic assumptions¹ concerning wood supply, costs, and other procurement considerations which led to the initiation of this feasibility investigation.

Vermont is 73 percent forested. At its current rate of growth, there is an annual growth surplus after harvests of 1.8 million tons of wood. It takes about 7.5 tons of wood each year to fuel a one-kilowatt electric generating plant. There should be, therefore, adequate annual surplus growth to fuel a plant one-half as large as the Vermont Yankee nuclear powered 550 megawatt

¹Beardsley, William, "Wood--An Electric Generating Fuel in Vermont--A Procurement Point of View", Green Mountain Power Corporation, private communication, June 12, 1974.

electricity generating plant.

In theory, and perhaps with improved forest management, Vermont's entire electricity requirements could be derived from wood. With the current price of fossil fuel hovering between \$1.50 - \$2.00 per million Btu, a competitive price for delivered green wood chips would be \$10.50 per ton (\$26.00 per cord, a stack of wood 4 Ft. X 4 Ft. X 8 Ft.)

The cost and benefit implications of a wood-fired electric generating plant for Vermont's forest industry, economy and environment will be internalized as part of the feasibility study.

The power plants operating on this type of fuel would have to be situated at "mine mouth." This is almost as restrictive as that required for location of an ocean thermal powered electric utility.

In view of the increasing awareness and concern with the political aspect, availability, reliability of supply, costs and the environmental and ecological effects of the fossil fuels, the conversion of organic materials into more readily useable fuel forms (like gas and light distillates) merits serious study.

In the conventional combustion (fire) process wood, straw or other vegetable matter is heated until it begins to release gases which burn and, in the burning process, heats other portions of the fuel so that more gases are released to be burned.

When organic material decays it yields useful by-products. The kinds of by-products depend upon the conditions under which decay takes place. Decay can be aerobic (with oxygen) or anaerobic (without oxygen). Any kind of organic matter can be broken down either way. Methane gas, an easily

transported fuel, is one by-product of anaerobic decay. The efficiency and rate of decay can be optimized artificially. The kinds of organic material used as "feedstock" also governs the quantity of gas produced per unit of organic matter.

The utilization of organic wastes for the production of methane⁽²⁾ should reduce the magnitude of the waste problem and be economically attractive.⁽¹⁾ Taking the present gas consumption as 2.2×10^{13} ft³/yr., the total current gas demand could be met by processing 2.2×10^9 tons of organic wastes through anaerobic digestors. Conversions of the dry organic fraction of the solid waste generated annually would yield 25 to 40 percent of the gas demand.

Not all of this can be collected since the available organic wastes are not sufficient to satisfy the current gas demand; it is necessary to consider, as an alternate or supplementary feedstock, the growth of crops specifically for their energy content. This results in a system which converts solar energy to methane via photosynthesis and anaerobic fermentation.

The Solar Energy Task Force report for the Project Independence Blueprint includes a section on bioconversion to fuels which can be paraphrased as follows:

The overall goal of the bioconversion to fuels program is to produce as much as 15×10^{15} BTU's (2.5×10^9 barrels of oil equivalent) in the year 2000 from energy crops (terrestrial and marine) and from organic wastes (urban solid waste and agricultural residues).

To achieve this level of production, an accelerated program of R & D and subsidized early commercial production facilities may be required as the estimated price of energy from these organic sources is not expected to be less than about \$2.00 per/BTU during this period. This price does
million

take into account credits for by-products in the form of food products and chemical feedstocks, which may be obtained in the production of biomass.

Energy planning systems are not expected to become economically attractive until the costs of alternative energy sources exceed the equivalent of \$11 per barrel of oil.

There must be a sequence of steps before a reliable and economically viable system can be established.

Deriving clean fuels from biomass or waste organic materials is the only "renewable" method of fuel production known. Two important considerations are present. First, the number of possible forms of energy crops, and conversion processes is very large. Second, the degree of development of the different production and conversion processes varies greatly.

The Project Independence Blueprint study contains a schedule showing the anticipated schedule for the research and development program which will lead to Proof-of-Concept. They are reproduced as Appendix II.

An R & D program has to be formulated and completed that will develop the technology base for large scale fuel and energy producing systems for:

- a) producing significant economic quantities of biomass
(feedstock plantation)
- b) converting this biomass into useful fuels and energy

The conversion processes will have two environmental consequences. Conversion of urban solid waste and agricultural residues (particularly feedlot wastes) will reduce many of the problems associated with disposal of these materials. Additionally, the residues from conversion of agricultural residues and energy crops may prove to be useful as organic

fertilizers, soil conditioners or as animal food supplements.

On the other hand, conversion of urban solid waste may produce waste water and filter cake with little utility and some potential disposal problems.

The biomass stock is low in sulfur content and most other pollutants characteristic of fossil fuels. Non-point source pollutants associated with agricultural operations may present some problems, especially with regard to fertilizers and pesticides. The large use of irrigation water presents salinization problems.

REFERENCES

- (1) Szego, George C. and Kemp, Clinton C., "Energy Forests and Fuel Plantations", Chemtech, May 1973.
- (2) Schneider, T.R., "Substitute Natural Gas from Organic Materials", ASME 72-WA/Ener-7, July 1972.
- (3) Green Mountain Power Corporation, Burlington, Vermont.

APPENDIX I

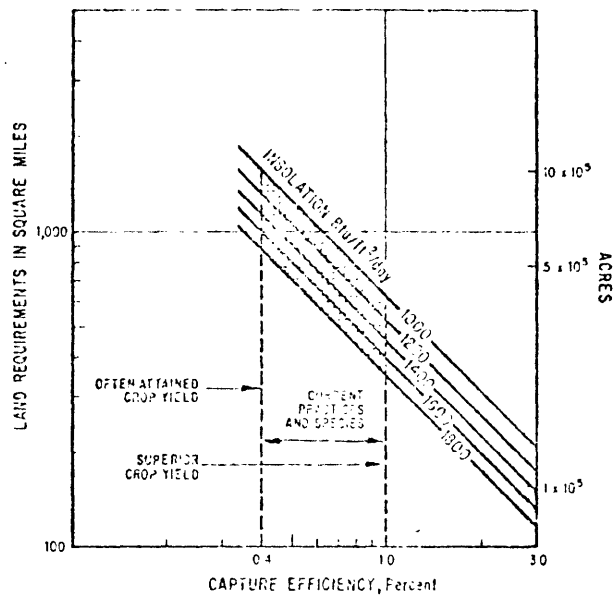

Figure 1. Land required for a 1000 MW steam-electric plant (35% efficiency, 75% load factor)

APPENDIX I

Land requirements

The land requirements for energy plantations are manageable. This conclusion is supported by a comparison with the land bases that support kraft pulp mills in the South.

At the end of 1971 there were 26 kraft pulp mills in the South having a daily production capacity of 1000 tons or more of pulp (23). Assume that

—1.7 cords of softwood are required per ton of pulp

—pulp mills operate 350 days a year

—75 percent of their pulp wood requirement is supplied as round wood (23)

—softwood growth yields are, on a sustained basis, about 2 cords per acre per year (a relatively high average yield), then about 350 square miles of pulpwood forest will thus be required to support a 1000 ton per day kraft pulp mill. An area about this big will support a 400 megawatt electric generating station even if only 0.4 percent of the solar energy incident on it is converted to fuel value, as the estimate in the next paragraph indicates.

Assume that the thermal efficiency of a generating station fired with plant fuel is about 35 percent. This efficiency, which is low for modern stations fired with conventional fossil fuels, is about equivalent to 10,000 Btu per kilowatt-hour. Further assume that the load factor of the station is 55 percent on an an-

nual basis (approximately the national average). Under these conditions the energy plantation land area required to supply the fuel for the station will be about 370 square miles. The energy plantation required to support a 1000 MW base load generating station (75 per cent load factor) at various insolation rates and conversions of solar energy to fuel value will be about as shown in Figure 1.

It may thus be concluded that since the area for an energy plantation adequate to supply a generating station of a capacity in line with many modern stations is of the same order of magnitude as the land areas presently being managed for each of two dozen large pulp mills, areas of similar size can be managed for energy plantations without serious difficulty.

Economics

Adoption of energy plantations as a significant source of fuel will depend in part on the cost of the fuel produced, and in part on the convenience with which it can be utilized. The cost of producing fuel value in an energy plantation will depend on:

—the yield of fuel per unit area per unit time (i.e., on Btu per acre per year), and

—the cost incurred per unit plantation area per unit time (i.e., dollars per acre per year).

(1) Szego, George C. and Kemp, Clinton C., "Energy Forests and Fuel Plantations" Chemtech, May 1973.

8-11
APPENDIX II

SUMMARY OF KEY MILESTONES AND RELATED DECISION POINTS

FY	MILESTONE	DECISION POINTS
75	<p>Initiate POCE: Process for Producing Methane Gas from Urban Solid Wastes (3)</p> <p>Initiate Total System Studies of Promising Energy Farming Concepts (1,2)</p>	<p>Final Review Engineering Systems Study Evaluation of Process</p> <p>Evaluation of Response to RFP and Award Contract (3)</p>
76	<p>Initiate Total System Study of Promising Agri-Waste Energy Conversion Opportunities (2)</p> <p>Initiate POCE Design Studies for Agri-Waste Energy Conversion Systems (4)</p>	<p>Review Panel Evaluation of Previous Engineering Systems Studies (2)</p> <p>As above plus Interim Results of Total System Study (4)</p>
77, 78, 79	<p>Complete POCE: Process for Converting Urban Solid Wastes to Methane</p> <p>Initiate POCE's Agri-Waste Energy Conversion Systems</p> <p>Complete Agri-Waste POCE's</p> <p>Initiate Energy Farming System POCE's</p>	<p>FY79 (1)</p> <p>FY77, FY78</p> <p>FY79 (2,3,4) FY80 (1,2)</p> <p>FY77 (2) FY78 (2) FY79 (2)</p>
80 - 85	<p>Initiate Demonstration Projects: Urban Solid Waste to Methane Process</p> <p>Agri-Waste Energy Systems</p> <p>Marine Energy Farm</p> <p>Terrestrial Energy Farms</p>	<p>FY80</p> <p>FY81</p> <p>FY81</p> <p>FY 81, FY 82</p>

Number in () refers to quarter of year in which activity is scheduled.

APPENDIX II (cont.)

FY	MILESTONES	DECISION POINTS
80 - 85	Complete Demonstration Projects:	
	Urban Solid Waste to Methane	FY82
	Agri-Waste Energy System	FY83
	Marine Energy Farm	FY85
	Terrestrial Energy Farm(s)	FY85, FY86

from Table 12 of the Report of the Task Force on Solar Energy of the Project Independence Blueprint Study, Federal Energy Administration, November 1974.

James W. Meyer
December 1, 1974

Monograph No. 9

MIT Energy Laboratory

HYDROGEN FUEL

Recently, hydrogen has received attention as a possible alternative fuel to natural gas, for the following reasons:

- 1) Reserves of natural gas are severely limited and are being depleted rapidly;
- 2) Reserves of petroleum, and especially tar sands and oil shale are somewhat limited, but the latter two are recoverable only at higher costs and are facing serious opposition from the environmentalists;
- 3) Reserves of coal are relatively large, but mining costs promise to rise steeply as increasing quantities required for liquefaction, gasification, etc., are mined from increasingly unfavorable deposits;
- 4) A clean gaseous fuel will apparently always be needed to fill the country's pipelines. Hydrogen is the prime candidate here if natural or synthetic methane becomes unavailable or unattractive; and
- 5) Today's indications are that electrical power generation in the long run will increasingly be taken over by nuclear plants of enormous size, operating in remote locations near large volumes of cooling water. There are indications that this electrical energy might be advantageously converted to hydrogen, both to supply the needed fuel gas and to obtain the economy of low gas transmission costs relative to electric energy transmission.

Hydrogen's suitability as a natural gas substitute derives from the following:

- 1) Hydrogen of high purity can be made by water-decomposition, so operated that only water and energy are consumed. The by-product oxygen produced can be safely vented into the atmosphere without pollution hazard. The raw material required, namely water, is

available in substantially limitless supply; and

- 2) Hydrogen burns to produce only water when combusted only with oxygen; thus, formation of the usual undesirable pollutants, namely CO, unburned hydrocarbons, sulfur compounds, and particulates, is entirely avoided. As when burning any fuel in air, nitrogen oxides will form in combustions when carried out at high enough temperatures. Formations of these undesired oxides can be minimized, as usual, by operating at lowest possible temperatures.

Hydrogen's characteristics as a fuel can be judged from the following:

- 1) Comparing on a volume basis, hydrogen has about 1/3 the heating value of natural gas. Thus, if methane saturated with water vapor shows a "higher" heat of combustion of 1000 Btu per cubic foot (60°F, 30" water), hydrogen is 313 Btu/cubic foot under the same conditions;
- 2) Hydrogen's use involves hazards somewhat greater than with natural gas: its flammability limits (4% to 75% in air) are much wider than for methane (5% to 15%) or for any other gas, for that matter; its low viscosity relative to other gases means that hydrogen escapes more rapidly through a given leak; the energy required for ignition of an explosive mixture of hydrogen in air is smaller than for methane. Hydrogen burns with a substantially invisible flame, which could, however, be rendered visible with suitable additives. Hydrogen is colorless, but could be supplemented with the same odorizers (mercaptans) as natural gas;
- 3) With proper burner and settings, hydrogen can be burned in household appliances about as successfully as natural gas;
- 4) Hydrogen, unlike natural gas, undergoes "flameless" combustion when passed (mixed with air) through a process plate filled with a catalyst. The heat evolved in this porous plate is re-radiated; thus these plates act as "hot plates." Such heating may be of importance for appliances;
- 5) Hydrogen uniquely is an excellent fuel for fuel cells operating at near atmospheric temperature with aqueous electrolytes; and
- 6) Hydrogen can, of course, serve as fuel for properly designed

internal and external combustion engines.

Hydrogen can be used with relatively high efficiency in a fuel cell.

- 1) The efficiency of hydrogen use in a fuel cell is a sensitive function of current density, cell design, etc. It is probably possible to attain an 80% efficiency here in converting hydrogen's energy to electrical energy.
- 2) It seems probable that the energy efficiency of interconverting electrical energy and hydrogen is 80% either way. Thus, an overall energy efficiency of 64% in converting electrical energy to hydrogen and back again to electrical energy appears reasonable.

Hydrogen transmission through gas pipelines may present new problems:

- 1) A gaseous hydrogen pipeline grid, 130 miles long, is operated in the Ruhr by Chemische Werke Huls A.G., with diameters of from 6 to 12 inches and a design pressure of 250 psi. Seamless steel pipe (SAE 1015) is used, with no compressor stations needed. There is reportedly a 50 mile hydrogen line in South Africa. Air Products Inc. operates near Houston, Texas, a 15 mile long hydrogen line, 8" in diameter, at 200 psi;
- 2) There is a tremendous background of know-how on natural gas pipelines, relatively little on hydrogen lines. Whether hydrogen could safely be put through existing natural gas lines and compressor stations, apparently remains to be established. There seems little doubt that pipelines designed specifically for hydrogen can be built using existing technology;
- 3) Hydrogen transmission costs by pipeline can only be approximated at this time. These transmissions cost per mile are a sensitive function of through-put (pressure and pipe diameters), pumping costs as influenced by fuel costs, and terrains as this affects capital costs. All these factors are optimized in pipeline design. It is to be remembered that costs also depend on the load factor;
- 4) Costs per mile of transmissions of 10^3 cubic feet of hydrogen, very roughly, will be about the same as for 10^3 cubic feet of natural gas, assuming total flows, pressure, etc., comparable. Thus, per million Btu costs for hydrogen are three-fold those for natural

gas. Very roughly typical costs of transmission of one-thousand cubic feet of natural gas (10^6 Btu) is around 2¢ per 100 miles in larger pipe. Thus, costs of transmission of one million Btu of energy as hydrogen would be 6¢ per 100 miles (6.8¢/1000 kWh/100 miles versus 20.4¢/1000 kWh/100 miles); and

- 5) Hydrogen might alternatively be transported cryogenically in tanks as a liquid, or in solid combination as a hydride. Such possibilities are highly speculative, and are "far out."

Hydrogen can be generated from water and electrical energy by electrolysis:

- 1) Water Electrolysis, whereby water is decomposed to gaseous hydrogen and gaseous oxygen, is an old art. Water electrolysis has never been an important source of hydrogen industrially, because of the high costs of the electrical energy required (roughly 90 kW hours for 1000 cubic feet of H_2 and 500 cubic feet of associated oxygen). Only in remoter regions of countries like Norway and Canada, where electricity has been available at 1 to 2 mills/kWh, has hydrogen been produced electrolytically for large scale use;
- 2) In this country, the enormous quantities of hydrogen consumed in petroleum refining, ammonia productions, etc., have come from reactions of steam with natural gas, petroleum fractions, and to a limited extent, with coal. By these routes, hydrogen is far cheaper today than by electrolysis. Of course, as fossil fuel costs increase due to decreased availability, electrolysis using relatively cheap electrical energy (from nuclear plants) will become more attractive;
- 3) Because of the low level of industrial interest, electrolytic hydrogen plants are not highly evolved, and cost data are not abundant or trustworthy. Designs have come typically from European engineering concerns, who are especially secretive. The Allis Chalmers Corporation in this country estimates investment costs (based upon an assumed advanced plant design) of \$37,500,000 for a capacity of 44,000 lbs. H_2 /hour (equivalent to 400,000,000 cubic feet/day, or 16.7 million cubic feet per hour. This plant cost is probably significantly underestimated,

but nevertheless is smaller by almost an order of magnitude than the costs of the large SNG Lurgi plants planned in this country;

- 4) Theoretical energy needs by electrolysis, when operating at or relatively near to room temperature, are 82 kW hours for 1000 cubic feet of hydrogen. Actual operations (all depending on cell design, current densities, temperature, operating pressures, etc.) are around 90 kW hours per 1000 cubic feet of H₂; and
- 5) By the Allis Chalmers design, operating costs have been estimated as follows:

Per day (400,000,000 cubic feet H ₂ /day)	
Labor, Maintenance, etc.	\$ 3,100
Energy, 36 x 10 ⁶ kW hours @ ½¢	180,000
Depreciation @ 5%	<u>5,000</u>
	\$189,000

The foregoing shows the overriding importance of the electrical energy cost component. Note that theory shows this cost cannot be reduced more than about 10% at most.

Hydrogen production from water plus energy available only as high temperature heat has been proposed, but success here is by no means assured.

- 1) While design problems will be significant, nuclear reactors could probably be designed to make large quantities of heat available at as high as 1000^o C. Very little increase in this temperature is foreseeable at this time. This heat would be available in cooling tubes somehow passing through the reactors. For safety, the heat absorbing medium flowing through these tubes, in which air endothermal reaction presumably occurs, would have to be as controllable and "reliable" as water in boiler tubes.
- 2) Various reaction series can be proposed whereby, when operating between 1000^o and 25^o C (the surroundings temperature, or close to it), water can be made to decompose to its elements. Nothing would be consumed in this operation except heat and water, making

it a "thermal equivalent" of electrolysis, in which only electrical energy and water are consumed.

- 3) In theory, there are many reaction schemes whereby the above can be accomplished. Whether, however, either energy efficiency or equipment costs can be superior to those of an orthodox nuclear power plant operating on this same high temperature heat, plus a water electrolysis plant, remains to be demonstrated.

BIBLIOGRAPHY

Derek P. Gregory, "The Hydrogen Economy", Scientific American, Volume 228, Page 13, January 1973.

J. O'M. Bockris, "A Hydrogen Economy", Science, Volume 172, Page 1323, June 1972.

Alden P. Armagnac, "Hydrogen: Fuel of the Future?", Popular Science, Page 64, January 1973.

W. E. Winsche, K. C. Hoffman, F. J. Salzano, "Hydrogen: Its Future Role in the Nation's Energy Economy", Volume 180, Page 1325, June 29, 1973.

Robert L. Savage et. al. (Eds) "A Hydrogen Energy Carrier, Volume 1 - Summary NASA-ASEE University of Houston, Johnson Space Center, Rice University, 1973.

William J. D. Escher, "Prospects for Hydrogen as a Fuel for Transportation Systems and for Electrical Power Generation", Volume ORNL-TM-4306, September 1972.



Monograph No. 10
MIT Energy Laboratory
GAS TURBINES

A burner/boiler/steam engine (steam turbine) combination is a class of external combustion engine that is basic in the electric power industry. The gases from the burning fuel heat a fluid which drives a rotating machine connected to an electric generator.

A gas turbine is another class of external combustion engine. The gases from the burning fuel drive a rotating machine (turbine) directly. For electric power production, the gas turbine is connected to an electric generator.

Gas turbines have relatively low capital cost, short installation time, and can respond to load changes quickly. Large numbers have been recently installed by the electric utilities. The original motivation was to provide spinning reserve and peak power.

With the increased demand for electricity, the gas turbines are often used for periods of 2000 hours per year and more. The extended utilization of gas turbines has been a factor in the trend of the electric industry to install combinations of gas turbines and steam plants to generate electricity.

THE PATTERN OF THE PAST

The load pattern is a key determinant in the selection of generation technologies and in consequent fuel requirements. A typical composite weekly load pattern taken from the Federal Power Commission's 1970 National Power Survey report is shown in Figure 1.

Up to the early 60's fossil fuel fired under-boiler generating plants served in almost the whole range of load. New efficient plants were operated as nearly as possible full-time; older, less efficient, partially written off plants were used in the intermediate load range in which 12-14 hour operation, 5 days a week as an operational norm; still older, smaller plants would be placed on load only a few hours a day at the peaks. Hydro capacity, where available, would be used near the peaks also because of quick start-up capacity.

FIGURE 1

ELECTRICITY LOAD CURVE U.S.
(A TYPICAL UTILITY COMPOSITE EXAMPLE)

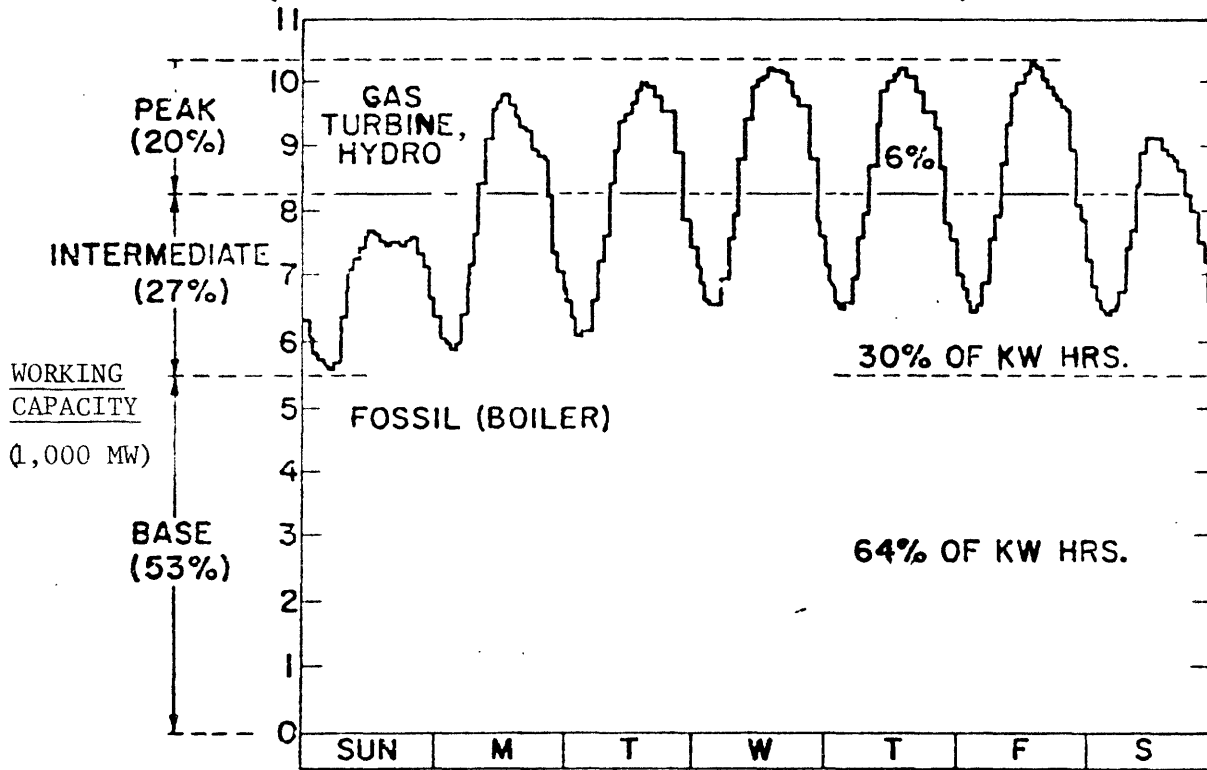

THE PATTERN OF THE FUTURE

A pattern for the future is shown in Figure 2. Until 1981 the data are taken from the National Electric Reliability Council's Fall 1972 report of utility plans. Much of this capacity for 1981 is already existent or under construction (especially the nuclear and the high pressure supercritical fossil). The forward projection for nuclear is the most recent AEC estimate: the total capacity projection is simply a run-out at the historic 7% per year growth rate, divided into peaking, intermediate and base load in the same ratio as for the 70's.

Important aspects of this pattern are:

- (1) Base load capacity most likely will be 50% nuclear within 8-9 years and perhaps 75% within 15 years.
- (2) Within 12-15 years (1985-1988) essentially all base load capacity will be of "nondemotable" types (i.e., nuclear and supercritical steam). From this point onward, all intermediate load capacity growth will have to be filled by the installation of new equipment-fuel systems specifically optimized for part-time service.
- (3) This new type intermediate load capacity "GAP" begins to open in the early 80s.*

A technology which might fill this "GAP" is the "gas turbine-steam turbine combination," also known as STAG (STeam And Gas Turbine) or PACE (Power At Combined Efficiency).

Due to the delays in commissioning dates for new base load stations which have been caused in the last few years by environmental considerations, regulatory problems and design and construction delays, some utilities have decided to ensure themselves against a shortage of base load capacity in the mid-70's by beginning to order new "combo" units now, since they can be had with a 2-3 year delivery time. This movement began in 1972 when 6300 MWe were placed on order. Since the forces which caused this advance ordering are continuing, a more realistic expectation for the "GAP" could take place in 1974 instead of in 1981, as shown in Figure 3.

* A basic assumption in this calculation was that the annual commissioning of new under-boiler type capacity for base load will drop to a negligible amount by 1981. This is the only assumption which is consistent with present technology trends, present ordering trends, and present utilities' planning. The validity of this assumption, and the consequences of various kinds of deviation, are explained in the Addendum.

FIGURE 2

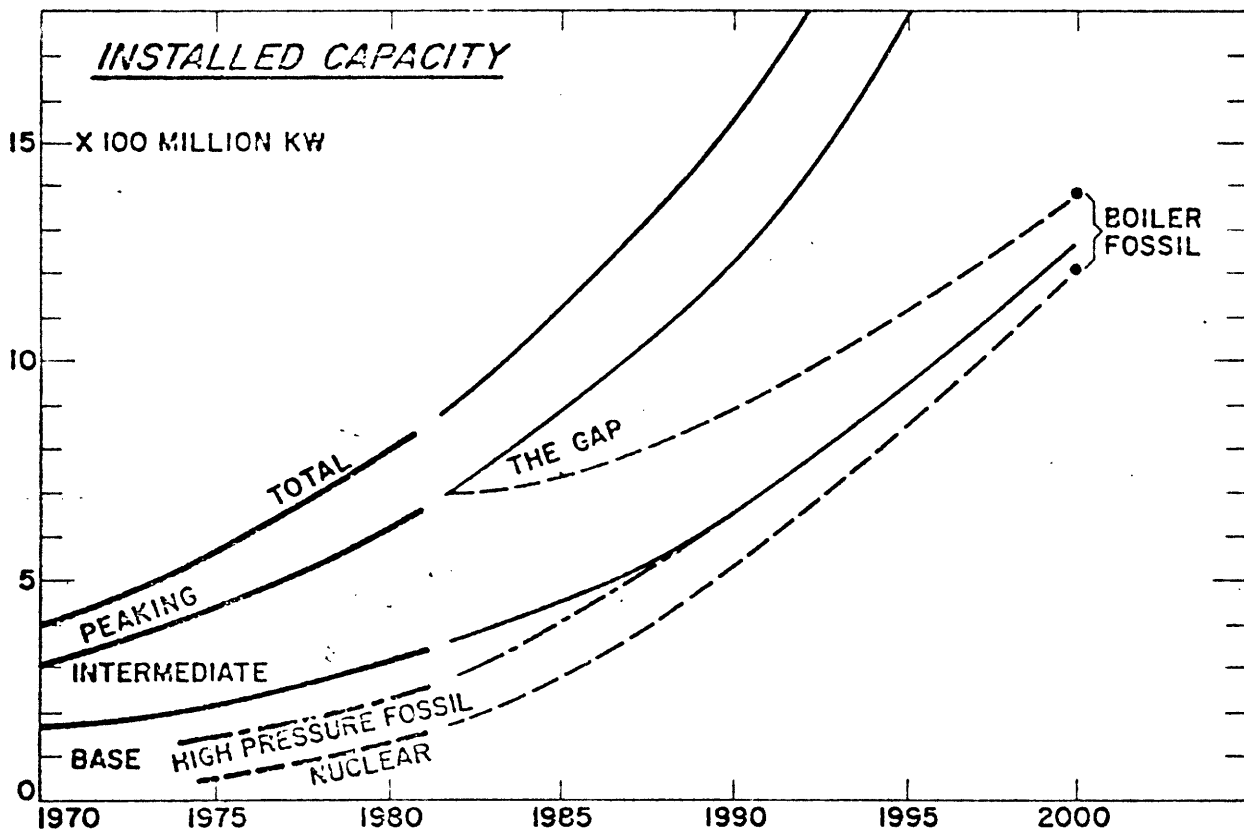

"Gap between projected installed capacity of electric power plants and demand."

Source: Federal Power Commission

This implied growth of gas turbine-steam turbine combination capacity is plotted directly in Figure 2, 3, 4 and 5.

In the combined system, a fuel is burned and the hot gases therefrom drive the gas turbine. The exhaust (the hot gases) from the turbine, still at a very high temperature, are used to generate steam. This steam then drives a conventional steam turbine. The gas turbine and the steam turbine each drives its own electric generator.

The present efficiency of a gas turbine alone is about 25%. The efficiency of a fossil fired steam plant may be about 35%. The thermal efficiency of a combined gas turbine/steam turbine power plants which are due to come into operation this year will be slightly below 40%.

The efficiency of the steam turbine portion of the combined cycle system has, for all practical purposes, reached its limit.

It is anticipated that gas turbine efficiencies can, within a decade, reach 35% and, in another decade, 40%. The advances in thermal efficiencies described above can only be achieved if the improvements in high temperature materials, turbine cooling techniques and aerodynamic design derived from current aircraft engine programs can be translated into higher maximum operating temperatures and cycle pressure ratios in industrial gas turbines for electric utility applications.

The combined cycle systems could reach efficiencies between 40% and 50% at the end of this decade and during the next decade could move towards 55%.

Since conventional nuclear power plants have efficiencies around 32% it is reasonable to ask why one would choose plants with a thermal efficiency limited to about 32%, rather than those presently 40% efficient and expectations of reaching 50% to 60%.

Special Problems

There are a number of considerations. Some are important only in light of assumed objectives and others represent constraints that greatly limit the number of opportunities to use gas turbines alone or in combination with steam and turbines.

FIGURE 3

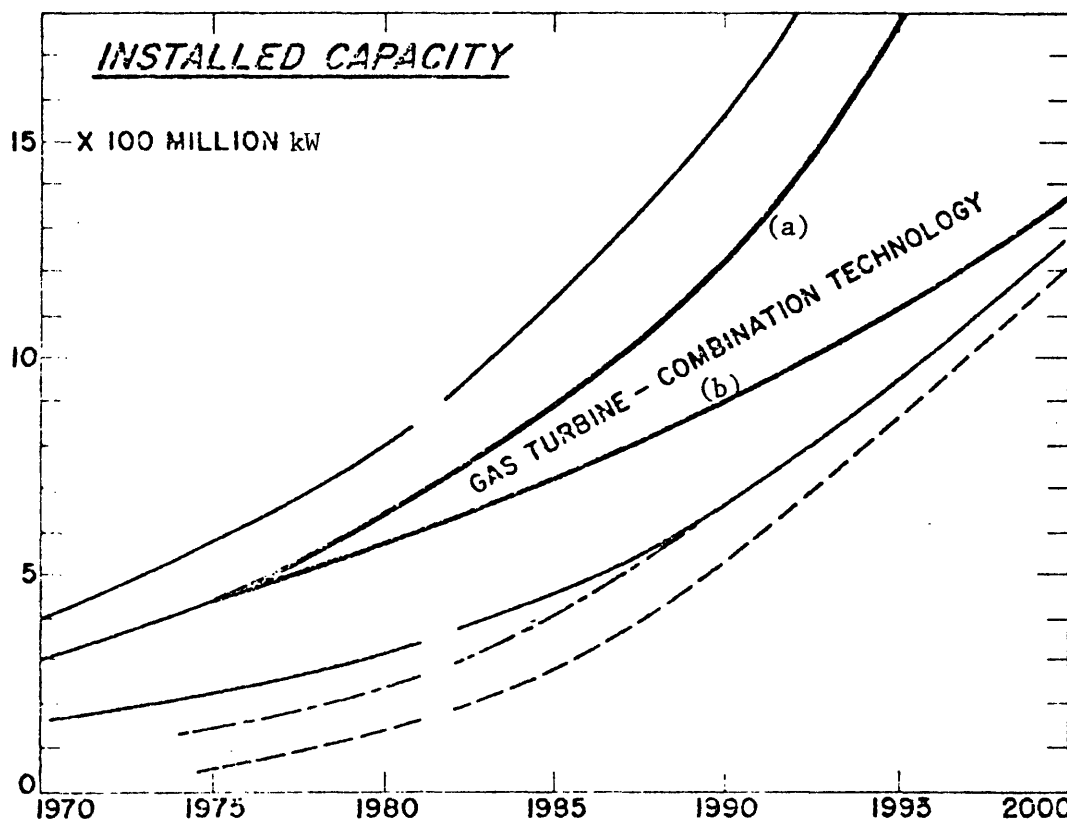

Recommended scheme for filling gap between unfilled demand (a) and capacity (b).

Source: Federal Power Commission

This implied growth of gas turbine-steam turbine combination capacity is plotted directly in Figure 4.

FIGURE 4

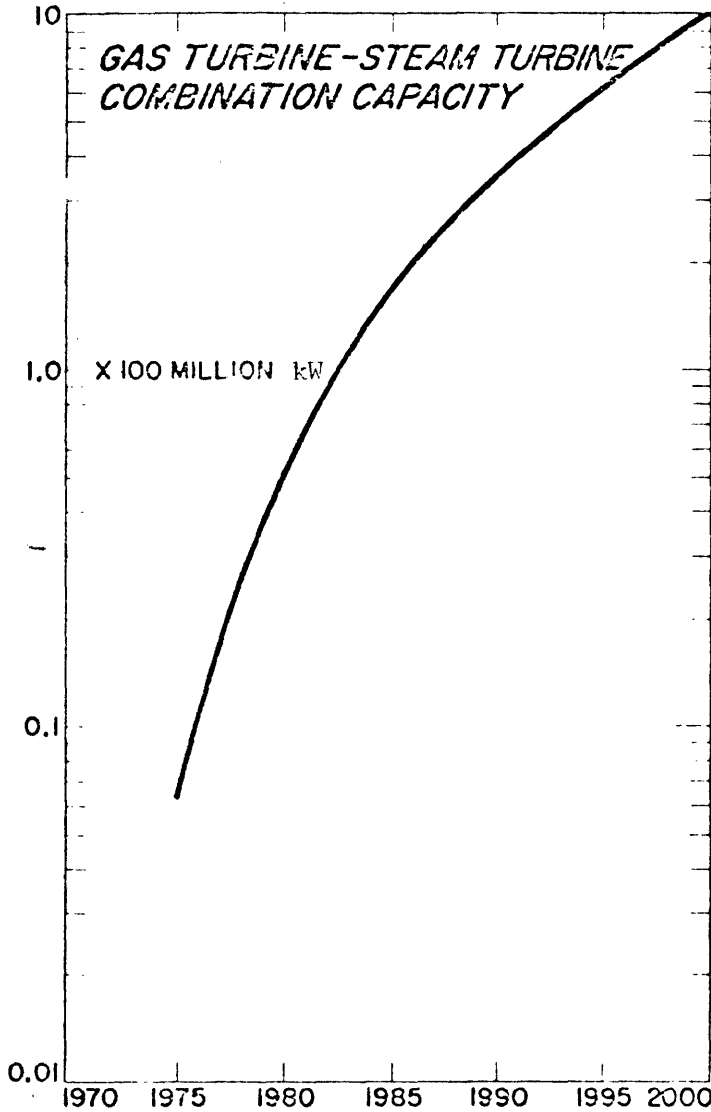
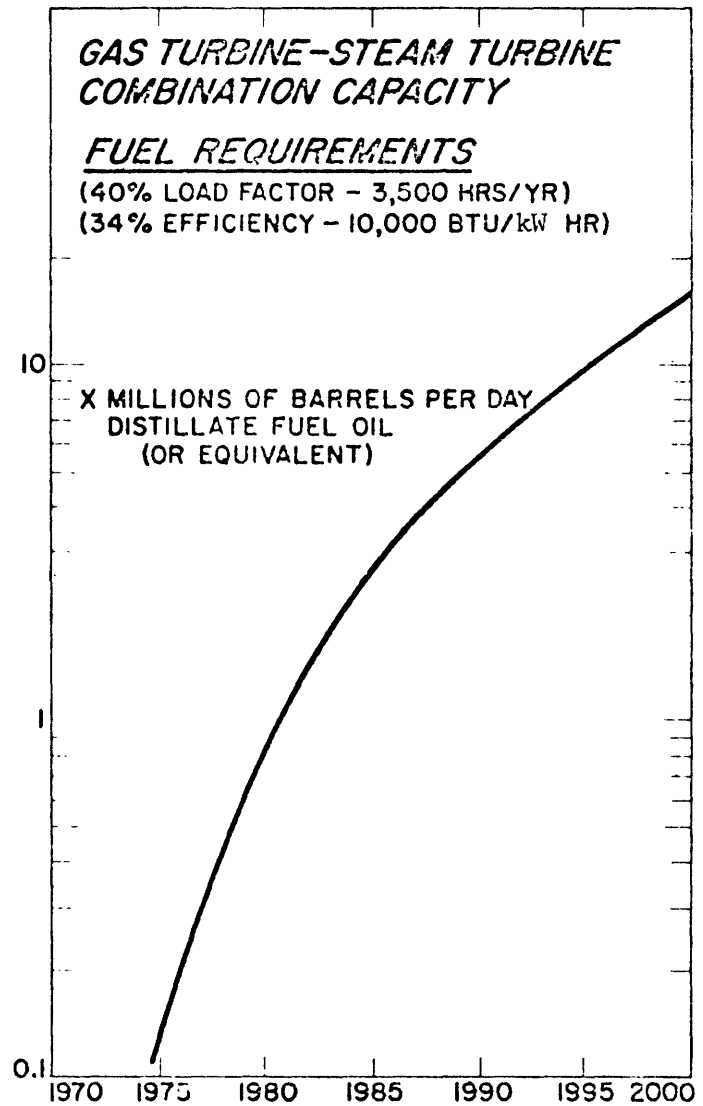

FIGURE 5



Only light petroleum distillates such as numbers 1 and 2 and diesel fuel, natural gas, butane, propane and low Btu gas, free of harmful alkali and sulphur compounds, can be used in advanced gas turbines. Heavy residual fuels which are used in conventional fossil fixed electric power plants would seriously reduce the maximum operating temperatures in order to avoid erosion, ash deposition, vanadium corrosion and sulfidation of turbine blades and vanes. Coal cannot be burned directly.

If more readily available coal, heavy oils, etc., are to be used, they have to be converted into a clean liquid or gaseous fuel. The conversion of heavy oil and coal into a clean high or low Btu gas results in a loss of some of the energy in the original fuel, hence the overall efficiency is reduced. It is necessary, therefore, to use fuels which are in short supply, or await the development and construction of facilities which can convert more abundant, but unsuitable, dirty fuels to clean fuels.

Size of Gas Turbines

Present gas turbines are of sizes up to around 60 megawatts; however, it may be expected that the maximum size of industrial gas turbines may soon double. With a power turbine operating at 1800 RPM instead of 3600 RPM, units up to around 250 MW could be developed.

It has been suggested that one could develop an integrated system (coal gasifiers, low and high temperature cleanup processes and combined cycle systems); however, the development would have to be preceded by a study devoted to identifying the areas of technology needing exploration in order to realize the advantages of the integrated system. Then there would be a need to further analyze the various identified technologies in order to define actual programs needed to bring them to commercial realization.

An electric generating power plant is a complex system in itself. To include a complete coal gasification or liquifaction plant would require a new organization of engineers and technicians at each plant. Disposal of the residue (ashes, etc.) at or from the electricity generation site may not be feasible.

Gas Turbines and Pollution

Simple and complex cycle gas turbines can be used where the availability of cooling water is limited. Combined cycles provide means to reduce the amount of heat rejected at the condenser per unit of electric power produced. Since gas turbines have to burn clean fuels free of sulfur, alkali and lead content, nitrogen oxides are the main pollutants to be concerned with. The combustion of fossil fuels with air results in the formation of nitrogen oxides in all power systems. Further, the control of NO_x in the stack gases is quite complex, since nitric oxide is relatively unreactive. Thus, the most attractive method of NO_x control is to limit their formation in the combustion products and in their subsequent cooling. The amount of NO_x formed depends on the conditions in the primary combustion zones and on the subsequent temperature and concentration distribution of the combustion products.

The combustor primary zones are operated at near stoichiometric conditions and recirculation is used to enhance complete combustion. High primary zone temperature and long residence time promote NO_x formation. In stationary power plants, water injection can be used to cool primary combustion gases before much NO_x is formed. Premixing of fuel and air can also be used to obtain lean primary combustion, achieve lower flame temperature and reduce the NO_x formation. The appreciable mass flow of low Btu gas to air ratio should allow good premixing and good sub-stoichiometric combustion. It would therefore appear that the NO_x emissions achievable in advanced gas turbines can be maintained at a low permissible level without compromising turbine performance.

The site location considerations of a combined-cycle and fuel processing plant are many orders of magnitude more complex. The sources of fuel (there should be a minimum of two), required transportation facilities environmental impact of the fuel processing plant and disposal of the unique effluents (keeping in mind that the residues are not conventional ash) and the overall system economics are issues that would be added to those present for a conventional utility.

It is possible to generate 2000 megawatts with a plurality of small combined systems. The economics and complexity of such an installation need detailed study.

Major technology changes, environmental and societal concerns are altering electricity generation and its fuel consideration. The requirement for clean gaseous or liquid fuels for gas turbines and conceivably other technologies too, will have to be sufficient to warrant the time and effort for research, development and construction stages. Gas turbines fuel requirements are in competition with present domestic, commercial and industrial demands. Clean fuels in necessary quantities to eliminate the need for nuclear or high pressure supercritical, or other sources of energy, will not be available for two decades.

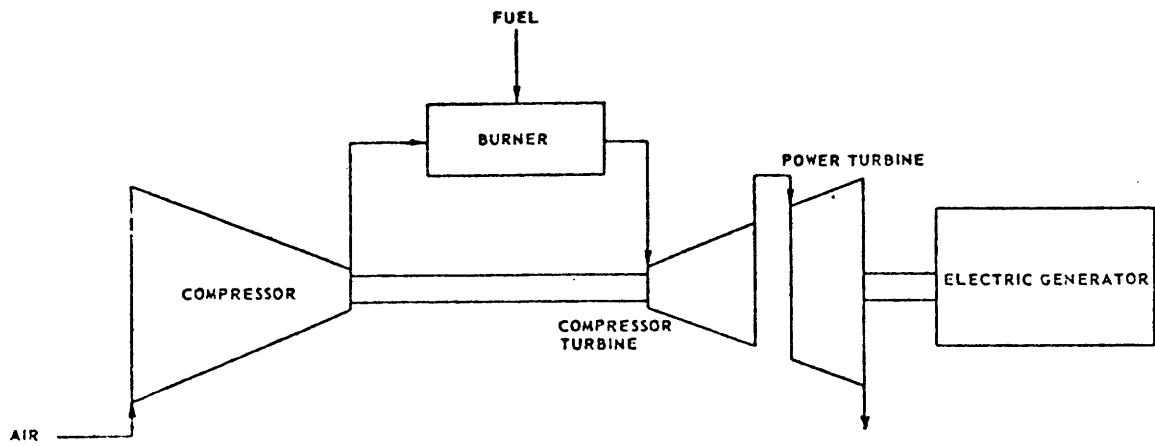

Gas Turbine

Figure 6

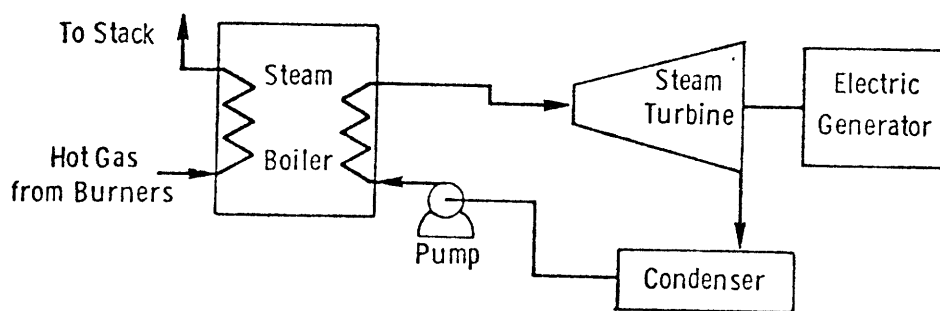

Steam Turbine

Figure 7

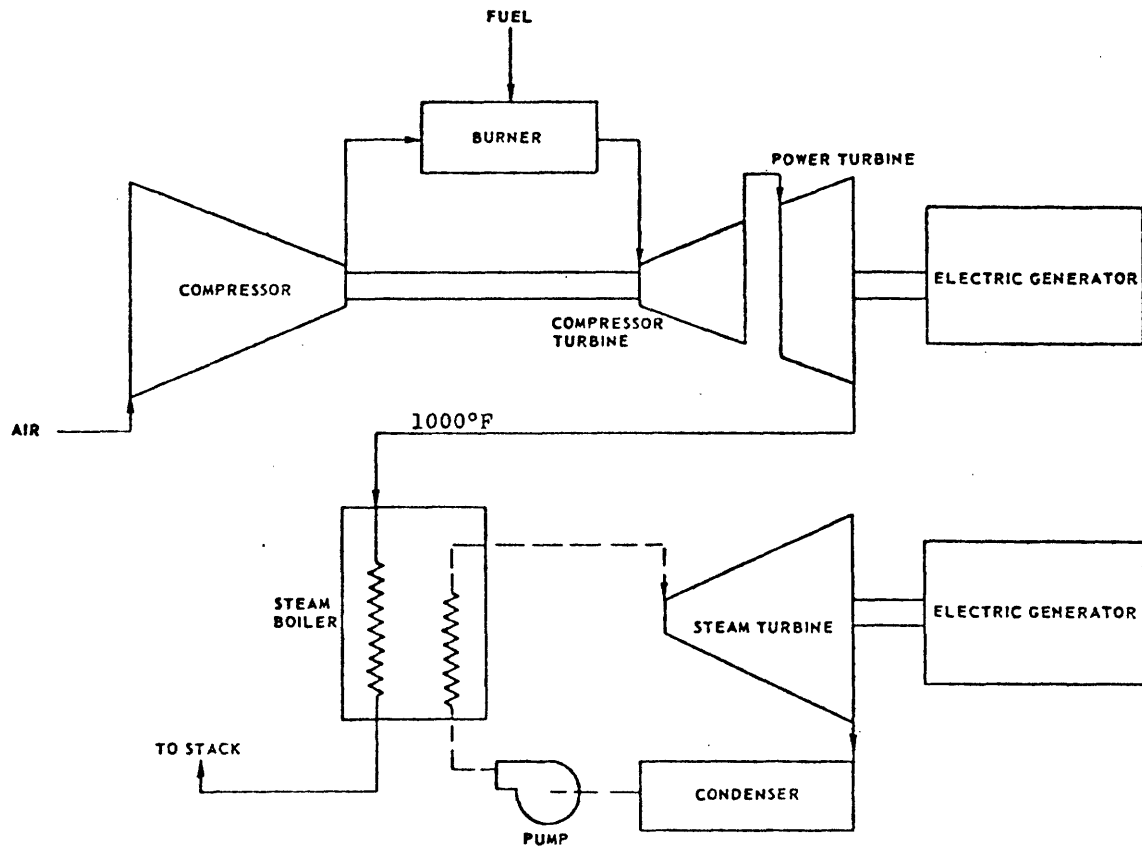

Combined Cycle System

Figure 8



Monograph No. 11
MIT Energy Laboratory
FUEL CELL GENERATION OF ELECTRIC POWER

To solve the problem of providing electric power for space vehicles and for certain military application, the federal government provided funds for fuel cell research which peaked at about \$16-million in 1963 and had fallen off to about \$3-million in 1970. Only one company, Pratt & Whitney Aircraft, division of United Aircraft Corporation, East Hartford, Connecticut, persisted in the direction of providing a commercialized fuel cell system with potential application to electric utility systems.

The basic fuel for fuel cells is hydrogen and oxygen which, when reacted in a cell, produces electric power and forms water as a by-product. A fuel cell power plant also contains a reformer and an inverter. The reformer is a chemical reactor which converts the primary fuel (e.g. natural gas, distillate fuel oil, methanol) into hydrogen for use in the fuel cell with oxygen derived from the air. The inverter changes the direct current output of the fuel cell into alternating current at the frequency and voltages required for distribution and use in conventional electric utility circuits.

Commercial applications approached by the Pratt & Whitney program are three related but different size units:

- 1) On-site conversion of natural gas to electricity
- 2) Supplementary power plants to central station facilities
(25 to 100 megawatts)
- 3) Electric power for remote locations and unattended operation
(10 to 200 kilowatts)

Only Westinghouse Electric Corporation, Pittsburgh, Pennsylvania, has investigated the use of fuel cells for central station generation. Westinghouse has no present program for the commercialization of such units.

On-site generation of electricity for residences and small businesses has received most field testing thus far. Thirty-five natural gas companies formed a Team to Advance Research for Gas Energy

Transformation (TARGET) and have installed nearly sixty 12.5 kilowatt fuel cell power plants at 37 locations in the United States and Canada. A goal of the program was to demonstrate the commercial feasibility of providing all utilities for a residence or small business with but a single fuel: natural gas. The same units, perhaps with a different reformer technique to accommodate other primary fuels, have application also in the remote location category.

The program for the commercial development of supplementary power plants of a unit capacity of twenty-six megawatts (enough to provide electricity for a community of 20,000 people) has been supported by a group of electric utilities, and by Pratt & Whitney's own funds.

The electric utility industry plans to employ these units for dispersed power generation, a non-traditional approach, that locates generating units within the distribution network which disperses pollution sources, lessens transmission line requirements, and reduces reserve requirements. An advantage of the system is its agility in responding to changes in load. Units respond "instantaneously" (in less than a cycle) to a step load increase (or decrease) from zero to 100% of rated power. This makes the system particularly suitable to meet peak demands on a utility system which it can do more efficiently than can conventional peaking equipment.

The 26 MW FGC-1 Fuel Cell Power Plant being developed by Pratt & Whitney has a fuel equivalent heat rate of 8500 Btu/kWh at part load, and at full 26 MW output, 12,000 Btu/kWh reflecting a loss of plant efficiency at peak loads. This is to be compared with that of a conventional steam plant usually taken to be 10,300 Btu/kWh. Sulfur compounds are potentially harmful to Powercel because they poison the reformer catalyst. Both unsaturated and heavy hydrocarbons cause carbon formation in the reformer. Ammonia (nitrogen) deposits in the fuel cell, and water reduces the charcoal capacity. Liquid fuels suitable for FGC-1 are limited to:

Jet A

Jet B

Naptha

No. 2 Heating Oil

or the following gases:

Natural gas

Process gas

Propane

Butane

Hydrogen

The FGC-1 thus is competing for the premium fossil fuel and its effective heat rate exceeds that of a conventional steam system at its maximum rated continuous power of 26 MW.

Pratt & Whitney production plans are to deliver the first production generator in mid-1977 and to establish a manufacturing capability to deliver at least 50 generators by year 1980. These are the only fuel cell systems at this or comparable power levels this close to commercial service.

To replicate the generating capacity of a 1200 MW power plant with these fuel cell systems, operating at half rated power for maximum fuel efficiency, would require 90 units, nearly two years' production in the 1980s.

Northeast Utilities, Hartford, Connecticut has conducted studies of utilization economics. In particular, they compared the annual production costs of a 250 MW nuclear system with a 250 MW fuel cell power plant as a function of fuel cost at the substation. The base load fuel cell has lower annual production costs for fuel costs up to \$.80/MBtu. The nuclear fuel price was taken to be \$.21/MBtu. Fuel cell capital costs were taken to be \$165/kw and those for the nuclear plant as \$325/kw. If the nuclear installed cost is taken to be \$400/kw, the break-even fuel cost is greater than \$1/MBtu. Twelve-dollar-a-barrel oil is a fuel cost in excess of \$2/MBtu. Fuel and construction costs have changed dramatically since these studies were performed. The above figures are quoted only to indicate the economic context in which the study was done.

REFERENCES

Hammond, Allen L., William D. Metz, and Thomas H. Maugh II, "Energy and the Future," American Association for the Advancement of Science, Washington, D.C., 1973.

Thomas H. Maugh II, "Fuel Cells: Dispersed Generation of Electricity," Science, Volume 178, 22 December 1972.

W.J. Luecket, L.G. Eklund and S.H. Law, "Fuel Cells for Dispersed Power Generation," Paper presented at the IEEE meeting in New York, 1973.