

MASSACHUSETTS INSTITUTE OF TECHNOLOGY
ARTIFICIAL INTELLIGENCE LABORATORY

A.I. Memo No. 1423

May, 1994

A Simplified Method for Deriving Equations of Motion For Continuous Systems with Flexible Members

Neil C. Singer
Warren P. Seering

Abstract

A method is proposed for deriving dynamical equations for systems with both rigid and flexible components. During the derivation, each flexible component of the system is represented by a “surrogate element” which captures the response characteristics of that component and is easy to mathematically manipulate. The derivation proceeds essentially as if each surrogate element were a rigid body. Application of an extended form of Lagrange’s equation yields a set of simultaneous differential equations which can then be transformed to be the exact, partial differential equations for the original flexible system. This method’s use facilitates equation generation either by an analyst or through application of software-based symbolic manipulation.

Copyright © Massachusetts Institute of Technology, 1993

This report describes research done at the Artificial Intelligence Laboratory of the Massachusetts Institute of Technology . Support for the laboratory’s research is funded in part by the Advanced Research Projects Agency of the Department of Defense under Office of Naval Research contract N00014-91-J-4038. Neil Singer was supported by the Office of Naval Research Fellowship Program, and by C. S. Draper Laboratory’s Internal Research and Development Program.

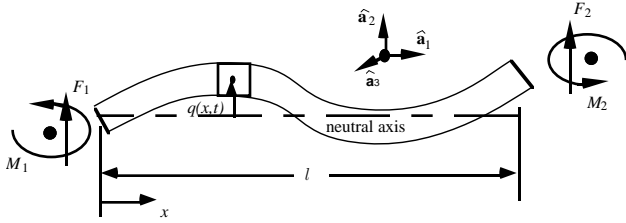

Figure 1: Forces and moments generated at the boundaries of a Bernoulli-Euler beam.

1 Introduction

Derivation of the exact partial differential equations describing motion of systems with flexible elements is at best tedious and at worst so difficult as to drive the analyst toward other pursuits. A method is presented here which simplifies the process of equation development for a wide variety of system configurations. The key to the method involves modeling each flexible component in the system as a single dynamic element which captures the essential characteristics of the flexible member. This “surrogate element”, which can be treated substantially as if it were a rigid body, stands in for the flexible member through most of the derivation. Any of the standard continuum models may be used in the form of a surrogate element (i.e. Bernoulli-Euler beam, Timoshenko beam, etc.) The method also works for systems with rigid body rotations. [Singer 92] demonstrates the use of the surrogate element using Kane’s Method.

First, the dynamic system is modeled with surrogate elements substituted for flexible members. State variables are then assigned. Next, any of the conventional methods for deriving system equations can be applied. When Lagrange’s method is employed, use of surrogate elements simplifies mathematical manipulations and eliminates the need to apply integration by parts. (Integration by parts is, generally, the most time consuming step in the solution process for continuous systems.) The equation generation process becomes very similar to that for systems made up of only rigid elements. This representation and derivation strategy was developed to facilitate computer generation of equations of motion for flexible systems. Its use also provides advantages when the equations are generated by the analyst.

2 The Surrogate Element

A flexible component in a dynamical system will typically exhibit the characteristics of both a mass and a spring. It will contain kinetic and potential energy and will exert forces and moments on adjacent components at its boundaries. If a flexible component is beamlike, it is frequently represented as a series of lumped elements, each with specified degrees of freedom. Bernoulli-Euler Beam elements and Timoshenko Beam elements are two common element representations. Each element of the series exerts a force and a moment only on its immediate neighbors. These forces and moments result from local deformations within the bodies. More specifically, the

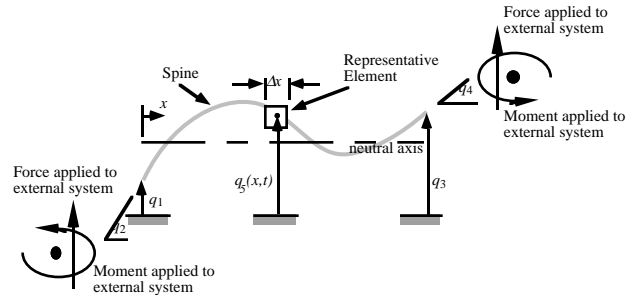

Figure 2: This is an example of a surrogate element.

load applied by an element depends only on the shape of the element at the point of application. (Of course, from a slightly different perspective, the shape is dependent only on the load.) An arbitrary number of similar elements can be chosen to represent a flexible component.

Just as the load applied by an element onto its neighboring element depends only on its shape at the boundary, the forces and moments applied by the entire flexible component onto adjacent lumped or flexible components are functions only of the flexible component’s shape (spatial derivatives) at its boundaries. For a Bernoulli-Euler Beam of length l , pictured in Figure 1, these forces and moments are [Crandall 82]

$$F_1 = -\frac{\partial}{\partial x} \left[EI \frac{\partial^2 q(x,t)}{\partial x^2} \right] \Big|_{x=0} \vec{a}_2 \quad (1)$$

$$F_2 = \frac{\partial}{\partial x} \left[EI \frac{\partial^2 q(x,t)}{\partial x^2} \right] \Big|_{x=l} \vec{a}_2 \quad (2)$$

$$M_1 = EI \frac{\partial^2 q(x,t)}{\partial x^2} \Big|_{x=0} \vec{a}_3 \quad (3)$$

$$M_2 = -EI \frac{\partial^2 q(x,t)}{\partial x^2} \Big|_{x=l} \vec{a}_3 \quad (4)$$

The sign convention chosen for these equations is as set by the directions of the vectors in Figure 1.

The surrogate element is a model or representation of a flexible component which can be used instead of a traditional continuous representation during equation generation. The surrogate element exhibits the essential dynamic characteristics of the component. It consists of a single elemental particle of the continuum (called a “representative particle”) and a spine defining the element’s shape. The element can exert forces and moments at the boundaries that connect it to the rest of the system. The surrogate element contributes a kinetic energy term because of motion of its elemental mass, and a potential energy term due to energy storage at the location of the representative particle. Because every internal particle of the continuum is topologically identical, the response of one particle can be used to represent that of the continuum. The forces and moments at the boundaries enforce the connection of the surrogate element to the rest of the system. (Appendix A justifies this description of the surrogate element.)

Generalized coordinates must be assigned to the surrogate element at each of the two boundary points and

at the representative particle (Table 1 shows coordinate selection for a variety of surrogate elements.) Frequently the generalized coordinates which locate the ends of the surrogate element will also locate the bodies to which the corresponding beam is rigidly attached.

To satisfy constraints set by Lagrange's method, the generalized coordinates locating the representative particle must be referenced to a coordinate system which is geometrically compatible with that of the bodies to which the surrogate element is connected. For example, in Figure 2:

$$\begin{aligned} q_1 &= q_5(0, t) \\ q_3 &= q_5(l, t) \\ q_2 &= \frac{\partial q_5(0, t)}{\partial x} \\ q_4 &= \frac{\partial q_5(l, t)}{\partial x} \end{aligned} \quad (5)$$

The condition of geometric compatibility is discussed in Appendix B. Note that the surrogate element in Figure 2 represents a Bernoulli-Euler beam and so the position of the representative point can be set with a single generalized coordinate [Crandall 82]. If this were a surrogate element for a Timoshenko beam, two generalized coordinates would be required to set both position and orientation at that point.

While the Bernoulli-Euler beam has only one coordinate for describing the motion of each beam element, two coordinates are required at each boundary to specify position and orientation of the end of the beam. This fact is consistent with the continuous derivation of the Bernoulli-Euler beam model [Crandall 82] and is not a product of the surrogate element definition. (The surrogate element concept simply highlights this anomaly.)

For the case of the Bernoulli-Euler Beam, the surrogate element has kinetic coenergy, potential energy, and Lagrangian given by

$$T^* = \frac{1}{2} \rho \Delta x (v_{abs})^2 \quad (6)$$

$$V = \frac{1}{2} EI \left(\frac{\partial^2 q}{\partial x^2} \right)^2 \Delta x \quad (7)$$

$$L_s = T^* - V \quad (8)$$

with terms as defined at the bottom of Table 1.

Note that the kinetic energy term contains the absolute velocity of the surrogate element's representative particle, v_{abs} . If the neutral axis of the beam is stationary, then $v_{abs} = \frac{\partial q}{\partial t}$. However, if the beam is rotating or translating, the absolute velocity of the representative particle must be determined (see Example 1). This is consistent with the specification of the kinetic energy of a lumped mass. Table 1 includes expressions for kinetic and potential energy for several types of surrogate elements.

In the derivation strategy developed below, surrogate elements are assumed to communicate with adjacent lumped components by applying loads to them. Table 1 includes expressions for these loads as they should appear in the equations. The lumped components will, in

turn, communicate with the surrogate elements through the enforcement of boundary position and orientation compatibility. The loads applied by adjacent components on the surrogate element are captured implicitly by these geometric constraints. Consequently, they are not included explicitly in the derivation (see Appendix A).

3 An Extended Form of Lagrange's Equations

The common expression of Lagrange's equations:

$$\frac{d}{dt} \left(\frac{\partial L}{\partial \dot{\xi}_j} \right) - \frac{\partial L}{\partial \xi_j} = \Xi_j \quad j = 1, 2, \dots, n \quad (9)$$

is valid for Lagrangians of the form, $L(\xi_1, \dots, \xi_n; \frac{d\xi_1}{dt}, \dots, \frac{d\xi_n}{dt}; t)$. Here Ξ_j (for $j = 1, 2, \dots, n$) are the generalized forces [Crandall 82]. When a system model includes surrogate elements, the potential energy terms become functions of the spatial derivatives of the ξ_i ; $\frac{\partial \xi_i}{\partial x}$ and $\frac{\partial^2 \xi_i}{\partial x^2}$. Appendix A demonstrates that a special form of Lagrange's equations,

$$\begin{aligned} \frac{\partial}{\partial t} \left(\frac{\partial L_s}{\partial \dot{\xi}_j} \right) - \frac{\partial L_s}{\partial \xi_j} + \frac{\partial}{\partial x} \left(\frac{\partial L_s}{\partial (\frac{\partial \xi_j}{\partial x})} \right) \\ - \frac{\partial^2}{\partial x^2} \left(\frac{\partial L_s}{\partial (\frac{\partial^2 \xi_j}{\partial x^2})} \right) = {}^s \Xi_j \quad j = 1, 2, \dots, n \end{aligned} \quad (10)$$

can be derived for systems whose models include rigid and surrogate elements. For this equation, L_s is the Lagrangian formulated to include surrogate element terms and the ${}^s \Xi_j$ (for $j = 1, 2, \dots, n$) are the generalized forces which include the loads applied by the surrogate elements onto adjacent components. The first two terms of Equation 10 are those of Equation 9. The last two terms are those required when spatial derivatives appear in the Lagrangian. This result is shown by [Lanczos 70] and [Meirovitch 90] and is also derived for use in Lagrangian density functions by Low and Vidyasagar [Low 88].

4 Derivation Strategy

The steps in a strategy for using surrogate elements to derive exact partial differential equations of motion for systems with flexible components will be described here. The description assumes the use of Lagrange's equation and is followed by a sample derivation chosen to illustrate application of the method.

1. Model the system as a collection of rigid and flexible elements.
2. Temporarily substitute for each flexible component a surrogate element.
3. Assign the required generalized coordinates to the surrogate elements. If the system configuration precludes motion in any direction, a generalized coordinate in that direction need not be included.

4. Assign any additional generalized coordinates required to specify the states of the system's rigid elements.¹
5. List the kinetic and potential energies of all surrogate elements as presented in Table 1.
6. List the kinetic and potential energies of the lumped elements.
7. From these terms for kinetic and potential energy, form a Lagrangian.
8. List the generalized forces. The portions of the generalized forces applied by the surrogate elements to adjacent components are given in Table 1.
9. Apply the extended form of Lagrange's equations to the Lagrangian for each state variable.
10. For those resulting equations for which the variable specifying the width of the representative particle is a common factor, divide through by it. In the example below, this variable is Δx . Note that these equations will be those for generalized coordinates representing displacements of representative particles from their neutral positions.
11. Integrate along the spine of each surrogate element those terms of the equations which still contain Δx , the variable specifying the width of the representative particle of the surrogate element. Performing this step removes the surrogate elements from the analysis and yields the exact, partial differential equations of motion and the boundary conditions for the system as modeled in step 1.

5 Example One

A flexible beam is fixed to a moving mass, m_b , as shown in Figure 3a. A mass, m_a , is connected to ground with a spring. m_b is constrained to move only vertically and is connected with a spring and a damper to m_a . The mass, m_c is connected to ground through a third spring. A distributed force, $f(x)$, is applied to the beam. System parameters are as presented in the figure.

Figure 3b shows the system with a surrogate element substituted for the flexible beam. Because the left end of the surrogate element spine cannot rotate, a generalized coordinate is assigned for translation (q_2) but not rotation. Coordinates q_4 and q_5 represent the displacement and rotation of the right end of the beam respectively. Coordinate q_1 locates mass, m_a . Note that q_2 , q_3 , and q_4 are all referenced to the same coordinate system; they all have been defined relative to mass, m_a .

The independent coordinates are chosen as:

$$\xi_i = q_i \quad i = 1, 2, \dots, 5 \quad (11)$$

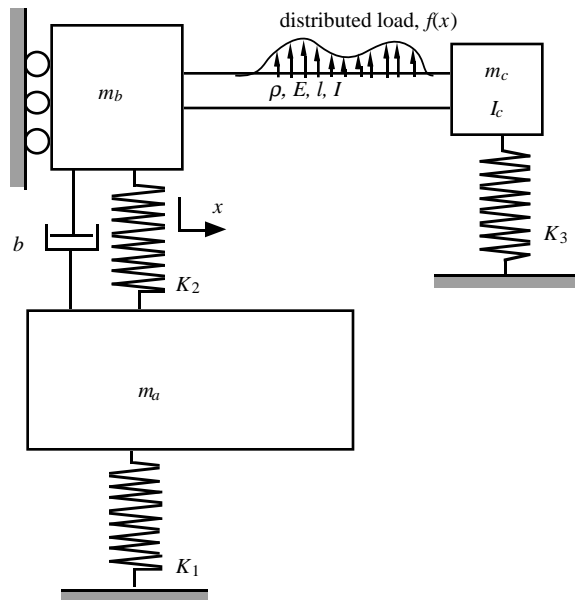

a) Model of system with both rigid body and continuous elements.

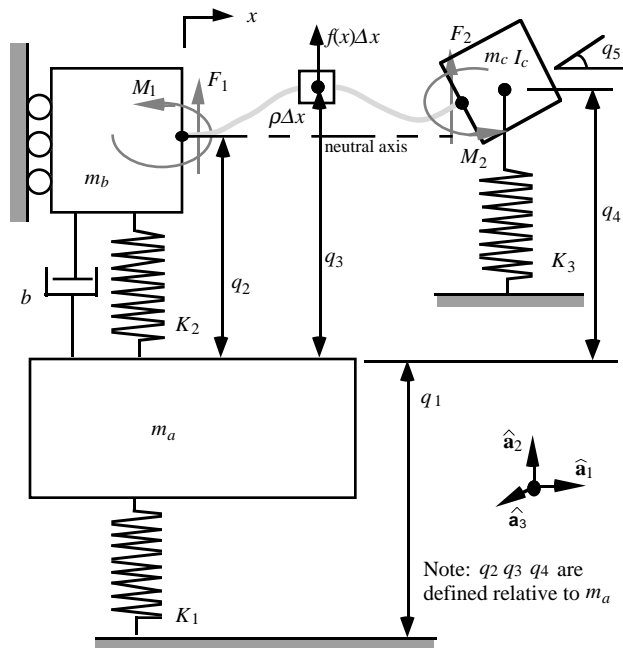

b) Model of system with surrogate element and assigned coordinates.

¹Be certain that the coordinates for the parts of the rigid system that connect to each surrogate element are defined to be compatible with the coordinates for the corresponding continuum. Appendix B elaborates on this requirement.

The kinetic coenergy, potential energy, and Lagrangian are expressed as:

$$T^* = \frac{1}{2}\rho\Delta x \left(\frac{\partial q_3}{\partial t} + \frac{dq_1}{dt} \right)^2 + \frac{1}{2}m_a \left(\frac{dq_1}{dt} \right)^2 + \frac{1}{2}m_b \left(\frac{dq_1}{dt} + \frac{dq_2}{dt} \right)^2 + \frac{1}{2}m_c \left(\frac{dq_1}{dt} + \frac{dq_4}{dt} \right)^2 + \frac{1}{2}I_c \left(\frac{dq_5}{dt} \right)^2 \quad (12)$$

$$V = \frac{1}{2}EI \left(\frac{\partial^2(q_3 - q_2)}{\partial x^2} \right)^2 \Delta x + \frac{1}{2}K_1q_1^2 + \frac{1}{2}K_2q_2^2 + \frac{1}{2}K_3(q_1 + q_4)^2 \quad (13)$$

$$L_s = T^* - V \quad (14)$$

Note that V is now a function of $\frac{\partial^2 q_3}{\partial x^2}$ (or $\frac{\partial^2 \xi_3}{\partial x^2}$).

The new generalized forces, ${}^s\Xi_i$, as defined in Section 3 are determined for each degree-of-freedom:

$${}^s\Xi_1 = f(x)\Delta x \quad (15)$$

$${}^s\Xi_2 = F_1 - b\frac{dq_2}{dt} \quad (16)$$

$${}^s\Xi_3 = f(x)\Delta x \quad (17)$$

$${}^s\Xi_4 = F_2 \quad (18)$$

$${}^s\Xi_5 = M_2 \quad (19)$$

For this example the terms to be substituted into Lagrange's equations (10) for $\xi_1 = q_1$ are

$$\begin{aligned} \frac{\partial}{\partial t} \left(\frac{\partial L_s}{\partial \dot{q}_1} \right) &= \frac{\partial}{\partial t} \left[\rho\Delta x \left(\frac{dq_1}{dt} + \frac{\partial q_3}{\partial t} \right) + m_a \frac{dq_1}{dt} + m_b \left(\frac{dq_1}{dt} + \frac{dq_2}{dt} \right) + m_c \left(\frac{dq_1}{dt} + \frac{dq_4}{dt} \right) \right] \\ -\frac{\partial L_s}{\partial q_1} &= K_1q_1 + K_3(q_1 + q_4) \end{aligned} \quad (20)$$

$$\begin{aligned} \frac{\partial}{\partial x} \left(\frac{\partial L_s}{\partial \frac{\partial q_1}{\partial x}} \right) &= 0 \\ -\frac{\partial^2}{\partial x^2} \left(\frac{\partial L_s}{\partial \frac{\partial^2 q_1}{\partial x^2}} \right) &= 0 \end{aligned} \quad .$$

The terms for $\xi_2 = q_2$ are

$$\begin{aligned} \frac{\partial}{\partial t} \left(\frac{\partial L_s}{\partial \dot{q}_2} \right) &= \frac{\partial}{\partial t} \left[m_b \left(\frac{dq_1}{dt} + \frac{dq_2}{dt} \right) \right] \\ -\frac{\partial L_s}{\partial q_2} &= K_2q_2 \\ \frac{\partial}{\partial x} \left(\frac{\partial L_s}{\partial \frac{\partial q_2}{\partial x}} \right) &= 0 \\ -\frac{\partial^2}{\partial x^2} \left(\frac{\partial L_s}{\partial \frac{\partial^2 q_2}{\partial x^2}} \right) &= 0 \end{aligned} \quad (21)$$

The terms for $\xi_3 = q_3$ are

$$\begin{aligned} \frac{\partial}{\partial t} \left(\frac{\partial L_s}{\partial \dot{q}_3} \right) &= \frac{\partial}{\partial t} \left[\rho\Delta x \left(\frac{dq_1}{dt} + \frac{\partial q_3}{\partial t} \right) \right] \\ -\frac{\partial L_s}{\partial q_3} &= 0 \\ \frac{\partial}{\partial x} \left(\frac{\partial L_s}{\partial \frac{\partial q_3}{\partial x}} \right) \Delta x &= 0 \\ -\frac{\partial^2}{\partial x^2} \left(\frac{\partial L_s}{\partial \frac{\partial^2 q_3}{\partial x^2}} \right) &= \frac{\partial^2}{\partial x^2} \left[EI \frac{\partial^2 q_3}{\partial x^2} \right] \Delta x \end{aligned} \quad (22)$$

The terms for $\xi_4 = q_4$ are

$$\begin{aligned} \frac{\partial}{\partial t} \left(\frac{\partial L_s}{\partial \dot{q}_4} \right) &= \frac{\partial}{\partial t} \left[m_c \left(\frac{dq_1}{dt} + \frac{dq_4}{dt} \right) \right] \\ -\frac{\partial L_s}{\partial q_4} &= K_3(q_1 + q_4) \\ \frac{\partial}{\partial x} \left(\frac{\partial L_s}{\partial \frac{\partial q_4}{\partial x}} \right) &= 0 \\ -\frac{\partial^2}{\partial x^2} \left(\frac{\partial L_s}{\partial \frac{\partial^2 q_4}{\partial x^2}} \right) &= 0 \end{aligned} \quad (23)$$

The terms for $\xi_5 = q_5$ are

$$\begin{aligned} \frac{\partial}{\partial t} \left(\frac{\partial L_s}{\partial \dot{q}_5} \right) &= \frac{\partial}{\partial t} \left[I_c \frac{dq_5}{dt} \right] \\ -\frac{\partial L_s}{\partial q_5} &= 0 \\ \frac{\partial}{\partial x} \left(\frac{\partial L_s}{\partial \frac{\partial q_5}{\partial x}} \right) &= 0 \\ -\frac{\partial^2}{\partial x^2} \left(\frac{\partial L_s}{\partial \frac{\partial^2 q_5}{\partial x^2}} \right) &= 0 \end{aligned} \quad (24)$$

Applying Equation 10 yields

$$\begin{aligned} & m_a \frac{d^2 q_1}{dt^2} \\ & + m_b \left(\frac{d^2 q_1}{dt^2} + \frac{d^2 q_2}{dt^2} \right) \\ & + \rho\Delta x \left(\frac{\partial^2 q_3}{\partial t^2} + \frac{d^2 q_1}{dt^2} \right) \\ & + m_c \left(\frac{d^2 q_1}{dt^2} + \frac{d^2 q_4}{dt^2} \right) \\ & + K_1q_1 + K_3(q_1 + q_4) = f(x)\Delta x \quad (25) \\ m_b \left(\frac{d^2 q_1}{dt^2} + \frac{d^2 q_2}{dt^2} \right) + K_2q_2 &= -b\frac{dq_2}{dt} \\ & -\frac{\partial}{\partial x} \left[EI \frac{\partial^2 q_3}{\partial x^2} \right] \Big|_{x=0} \\ & \rho\Delta x \left(\frac{\partial^2 q_3}{\partial t^2} + \frac{d^2 q_1}{dt^2} \right) \end{aligned} \quad (26)$$

$$+ \frac{\partial^2}{\partial x^2} \left[EI \frac{\partial^2 q_3}{\partial x^2} \right] \Delta x = f(x) \Delta x \quad (27)$$

$$m_c \left(\frac{d^2 q_1}{dt^2} + \frac{d^2 q_4}{dt^2} \right) + K_3 (q_1 + q_4) = \frac{\partial}{\partial x} \left[EI \frac{\partial^2 q_3}{\partial x^2} \right] \Big|_{x=l} \quad (28)$$

$$I_c \frac{d^2 q_5}{dt^2} = -EI \frac{\partial^2 q_3}{\partial x^2} \Big|_{x=l} \quad (29)$$

Dividing Equation 27 by Δx (Step 10) yields

$$\rho \left(\frac{\partial^2 q_3}{\partial t^2} + \frac{d^2 q_1}{dt^2} \right) + \frac{\partial^2}{\partial x^2} \left[EI \frac{\partial^2 q_3}{\partial x^2} \right] = f(x) \quad , \quad 0 < x < l \quad (30)$$

$$(31)$$

Terms in Equation 25 can then be integrated over the length of the beam (Step 11). For example,

$$\rho \Delta x \left(\frac{\partial^2 q_3}{\partial t^2} + \frac{d^2 q_1}{dt^2} \right) \Rightarrow \int_0^l \rho \left(\frac{\partial^2 q_3}{\partial t^2} + \frac{d^2 q_1}{dt^2} \right) dx$$

or

$$\int_0^l \rho \frac{\partial^2 q_3}{\partial t^2} dx + m_{\text{beam}} \frac{d^2 q_1}{dt^2}$$

where m_{beam} is the total mass of the beam.

The final set of partial differential equations (after Step 11) is:

$$\begin{aligned} & m_a \frac{d^2 q_1}{dt^2} \\ & + m_b \left(\frac{d^2 q_1}{dt^2} + \frac{d^2 q_2}{dt^2} \right) + \\ & \int_0^l \rho \frac{\partial^2 q_3}{\partial t^2} dx + m_{\text{beam}} \frac{d^2 q_1}{dt^2} \\ & + m_c \left(\frac{d^2 q_1}{dt^2} + \frac{d^2 q_4}{dt^2} \right) \\ & + K_1 q_1 + K_3 (q_1 + q_4) = \int_0^l f(x) dx \quad (32) \end{aligned}$$

$$\begin{aligned} m_b \left(\frac{d^2 q_1}{dt^2} + \frac{d^2 q_2}{dt^2} \right) + K_2 q_2 &= -b \frac{dq_2}{dt} \\ & - \frac{\partial}{\partial x} \left[EI \frac{\partial^2 q_3}{\partial x^2} \right] \Big|_{x=0} \quad (33) \end{aligned}$$

$$\begin{aligned} \rho \left(\frac{\partial^2 q_3}{\partial t^2} + \frac{d^2 q_1}{dt^2} \right) \\ + \frac{\partial^2}{\partial x^2} \left[EI \frac{\partial^2 q_3}{\partial x^2} \right] &= f(x) \quad (34) \end{aligned}$$

$$m_c \left(\frac{d^2 q_1}{dt^2} + \frac{d^2 q_4}{dt^2} \right)$$

$$+ K_3 (q_1 + q_4) = \frac{\partial}{\partial x} \left[EI \frac{\partial^2 q_3}{\partial x^2} \right] \Big|_{x=l} \quad (35)$$

$$I_c \frac{d^2 q_5}{dt^2} = -EI \frac{\partial^2 q_3}{\partial x^2} \Big|_{x=l} \quad (36)$$

6 Conclusions

A method has been proposed for deriving the partial differential equations of motion for systems of lumped and flexible components. When used in conjunction with Lagrange's method, the process of equation generation is significantly simplified. Particularly, integration by parts is no longer required. Both system equations and expressions of boundary conditions result directly from application of this method. The method contains the same simple steps used to derive the equations of motion for lumped parameter systems.

7 Appendix A

In this section it will be shown that the application of the surrogate element method yields correct equations of motion and boundary conditions when applied to a dynamic system of rigid and flexible elements. First, equations will be derived for a general system using the variational formulation. Then the surrogate element formulation will be employed, yielding identical equations.

A Lagrangian for a system of rigid and flexible components can be expressed as,

$$L = \sum_{j=1}^n L_{\text{flexible}j} + L_{\text{rigid}} \quad (37)$$

where $L_{\text{flexible}j}$ contains all of the kinetic and potential energy terms for the j th of n continuous elements, and L_{rigid} contains the rest of the terms, those not dependent on spatial orientation within an element. $L_{\text{flexible}j}$ is the sum of the energy terms for the elemental particles in the j th continuum, so the Lagrangian can be written

$$L = \sum_{j=1}^n \sum_{z_j} L_{fj} \Delta z_j + L_{\text{rigid}} \quad (38)$$

where the L_{fj} is a Lagrangian density function (see [Low 88] and [Meirovitch 90]) and z_j is a variable expressing the position of each element along the j th continuum.

The components of the Lagrangian for the system are expressed in functional form as

$$\begin{aligned} L_{fj} &= L_{fj} (r_i, \dot{r}_i, e_j(z_j), \dot{e}_j(z_j), \\ & e'_j(z_j), e''_j(z_j), t) \quad (39) \end{aligned}$$

$$\begin{aligned} L_{\text{rigid}} &= L_{\text{rigid}} (r_i, \dot{r}_i, e_j(z_{j_a}), e_j(z_{j_b}), \\ & \dot{e}_j(z_{j_a}), \dot{e}_j(z_{j_b}), e'_j(z_{j_a}), e'_j(z_{j_b}), \\ & \dot{e}'_j(z_{j_a}), \dot{e}'_j(z_{j_b}), t) \quad (40) \end{aligned}$$

where the r_i are state variables defining the positions of the m rigid elements (for $i = 1, 2, \dots, m$); the $e_j(z_j)$ are coordinates which define deflections within the flexible elements; z_{j_a} and z_{j_b} are the locations of the endpoints of the j th continuous element; and $e_j(z_{j_a})$ and $e_j(z_{j_b})$

Boundary Forces and Particle Energy Terms for Various Surrogate Elements ¹			
Continuum	Boundary Forces	Boundary Moments	Particle Energy Terms
Bernoulli-Euler Beam 	$F_1 = -\frac{\partial}{\partial x} \left(EI \frac{\partial^2 y}{\partial x^2} \right) \Big _{x=0} \hat{\mathbf{a}}_2$ $F_2 = +\frac{\partial}{\partial x} \left(EI \frac{\partial^2 y}{\partial x^2} \right) \Big _{x=l} \hat{\mathbf{a}}_2$	$M_1 = EI \frac{\partial^2 y}{\partial x^2} \Big _{x=0} \hat{\mathbf{a}}_3$ $M_2 = -EI \frac{\partial^2 y}{\partial x^2} \Big _{x=l} \hat{\mathbf{a}}_3$	$T^* = \frac{1}{2} \rho \Delta x \left(\frac{\partial y}{\partial t} \right)^2$ $V = \frac{1}{2} EI \left(\frac{\partial^2 y}{\partial x^2} \right)^2 \Delta x$
Timoshenko Beam 	$F_1 = \kappa GA \left[\frac{\partial \eta}{\partial x} - \phi \right] \Big _{x=0} \hat{\mathbf{a}}_2$ $F_2 = -\kappa GA \left[\frac{\partial \eta}{\partial x} - \phi \right] \Big _{x=l} \hat{\mathbf{a}}_2$	$M_1 = EI \frac{\partial \phi}{\partial x} \Big _{x=0} \hat{\mathbf{a}}_3$ $M_2 = -EI \frac{\partial \phi}{\partial x} \Big _{x=l} \hat{\mathbf{a}}_3$	$T^* = \frac{1}{2} \rho \Delta x \left(\frac{\partial \eta}{\partial t} \right)^2 + \frac{1}{2} I I \Delta x \left(\frac{\partial \phi}{\partial t} \right)^2$ $V = \frac{1}{2} EI \left(\frac{\partial \phi}{\partial x} \right)^2 \Delta x + \frac{1}{2} \kappa GA \left(\frac{\partial \eta}{\partial x} - \phi \right)^2 \Delta x$
Uniaxial 	$F_1 = EA \frac{\partial \xi}{\partial x} \Big _{x=0} \hat{\mathbf{b}}_1$ $F_2 = -EA \frac{\partial \xi}{\partial x} \Big _{x=l} \hat{\mathbf{b}}_1$		$T^* = \frac{1}{2} \rho \Delta x \left(\frac{\partial \xi}{\partial t} \right)^2$ $V = \frac{1}{2} EA \left(\frac{\partial \xi}{\partial x} \right)^2 \Delta x$
Torsion 		$T_1 = G I_p \frac{\partial \phi}{\partial x} \Big _{x=0} \hat{\mathbf{b}}_1$ $T_2 = -G I_p \frac{\partial \phi}{\partial x} \Big _{x=l} \hat{\mathbf{b}}_1$	$T^* = \frac{1}{2} I I \Delta x \left(\frac{\partial \phi}{\partial t} \right)^2$ $V = \frac{1}{2} G I_p \left(\frac{\partial \phi}{\partial x} \right)^2 \Delta x$
String In Tension 	$F_1 = P \frac{\partial \eta}{\partial x} \Big _{x=0} \hat{\mathbf{a}}_2$ $F_2 = -P \frac{\partial \eta}{\partial x} \Big _{x=l} \hat{\mathbf{a}}_2$		$T^* = \frac{1}{2} \rho \Delta x \left(\frac{\partial \eta}{\partial t} \right)^2$ $V = \frac{1}{2} P \left(\frac{\partial \eta}{\partial x} \right)^2 \Delta x$
Definitions: η = String local displacement ² ξ = Uniaxial Stretch ² ϕ = Rotation of Beam Particle ² y = Beam local displacement ²	x = Dimension along Continuum Δx = Elemental length of representative particle ² Referenced to neutral axis (undeformed initial position)	ρ = Mass per unit length P = String Tension l = Length of Continuum I_p = Torsional Constant I = Area Moment of Inertia II = Particle Area Moment of Inertia	κ = Shear Coefficient Shape: Rectangle = .83 Circle = .85 Typical I - Beam = .95 ¹ see references [Blevins 79] [Crandall 82] [Kane 85]

Table 1: This is a table of example surrogate elements

are the coordinates at those endpoints. Differentiation in time is denoted with a dot ($\dot{e}_j(z_j) = \partial e_j(z_j)/\partial t$); spatial differentiation is denoted with a prime ($e'_j(z_j) = \partial e_j(z_j)/\partial z_j$). The time derivative of $e'_j(z_j)$ is denoted as $\dot{e}'_j(z_j)$.

The L_{fj} functions contain the terms in L which are to be spatially integrated, while the L_{rigid} function includes the remaining terms. The L_{rigid} function contains continuous coordinates specified at the boundaries of the continuum (the $e_j(z_{j_a})$ and $e_j(z_{j_b})$). For a system of only rigid elements, a single variable would be selected to specify the motion of each rigid component. However, for mixed systems, coordinates assigned to continuous elements specify the motion of some rigid components of the system so additional variables are not needed. For example, in Figure 3, $q_3(0) = q_2$. For the variational approach, $q_3(0)$ appears in L_{rigid} . With the surrogate element approach, q_2 would be used instead.

7.1 The Variational Approach

The summation of the energy terms in Equation 38 becomes an integral when the continuous case is considered,

$$L = \sum_j \int_{z_j} L_{fj} dz_j + L_{\text{rigid}} \quad (41)$$

The Variational Indicator may be formed from the Lagrangian, L and the work, W , done by generalized forces:

$$\begin{aligned} \delta \int_{t_1}^{t_2} (L + W) dt = & \int_{t_1}^{t_2} \sum_j \int_{z_j} \delta L_{fj} (r_i, \dot{r}_i, e_j(z_j), \dot{e}_j(z_j), \\ & e'_j(z_j), e''_j(z_j), t) dz_j dt \\ & + \int_{t_1}^{t_2} \delta L_{\text{rigid}} (r_i, \dot{r}_i, e_j(z_{j_a}), e_j(z_{j_b}), \dot{e}_j(z_{j_a}), \dot{e}_j(z_{j_b}), \\ & e'_j(z_{j_a}), e'_j(z_{j_b}), \dot{e}'_j(z_{j_a}), \dot{e}'_j(z_{j_b}), t) dt \\ & + \int_{t_1}^{t_2} \left\{ \sum_i \Xi_{\text{rigid}_i} \delta r_i + \sum_j \int_{z_j} \Xi_{fj} dz_j \delta e_j(z_j) \right. \\ & + \sum_j \Xi_{\text{bc}1j} \delta e_j(z_{j_b}) + \sum_j \Xi_{\text{bc}2j} \delta e_j(z_{j_a}) \\ & \left. + \sum_j \Xi_{\text{bc}3j} \delta e'_j(z_{j_b}) + \sum_j \Xi_{\text{bc}4j} \delta e'_j(z_{j_a}) \right\} dt \quad (42) \end{aligned}$$

The Ξ_{rigid_i} are the generalized forces in the δr_i directions (associated with the rigid body coordinates). The Ξ_{fj} are the generalized forces in the $\delta e_j(z_j)$ directions (associated with the flexible coordinates). The $\Xi_{\text{bc}1j}$, $\Xi_{\text{bc}2j}$, $\Xi_{\text{bc}3j}$, and $\Xi_{\text{bc}4j}$ are the generalized forces in the $\delta e_j(z_{j_b})$, $\delta e_j(z_{j_a})$, $\delta e'_j(z_{j_b})$, and $\delta e'_j(z_{j_a})$ directions respectively.

These generalized forces are derived using the Principle of Virtual Work, and therefore do not contain internal force terms. The subscript $\Xi_{\text{bc}1} \dots \Xi_{\text{bc}4}$ refer to the Ξ 's associated with the four boundary coordinates of each flexible element.

The variation operator is applied to each term,

$$\begin{aligned} \delta \int_{t_1}^{t_2} (L + W) dt = & \sum_i \int_{t_1}^{t_2} \left\{ \sum_j \int_{z_j} \frac{\partial L_{fj}}{\partial r_i} dz_j \delta r_i + \frac{\partial L_{\text{rigid}}}{\partial r_i} \delta r_i \right. \\ & + \Xi_{\text{rigid}_i} \delta r_i + \frac{\partial L_{\text{rigid}}}{\partial \dot{r}_i} \delta \dot{r}_i \\ & + \sum_j \left[\int_{z_j} \frac{\partial L_{fj}}{\partial \dot{r}_i} dz_j \delta \dot{r}_i + \int_{z_j} \frac{\partial L_{fj}}{\partial \dot{e}_j(z_j)} dz_j \delta \dot{e}_j(z_j) \right. \\ & + \int_{z_j} \frac{\partial L_{fj}}{\partial e_j(z_j)} dz_j \delta e_j(z_j) + \int_{z_j} \Xi_{fj} dz_j \delta e_j(z_j) \\ & + \int_{z_j} \frac{\partial L_{fj}}{\partial e'_j(z_j)} dz_j \delta e'_j(z_j) + \int_{z_j} \frac{\partial L_{fj}}{\partial e''_j(z_j)} dz_j \delta e''_j(z_j) \\ & + \frac{\partial L_{\text{rigid}}}{\partial e_j(z_{j_a})} \delta e_j(z_{j_a}) + \frac{\partial L_{\text{rigid}}}{\partial e_j(z_{j_b})} \delta e_j(z_{j_b}) \\ & + \Xi_{\text{bc}1j} \delta e_j(z_{j_b}) + \Xi_{\text{bc}2j} \delta e_j(z_{j_a}) \\ & + \frac{\partial L_{\text{rigid}}}{\partial \dot{e}_j(z_{j_a})} \delta \dot{e}_j(z_{j_a}) + \frac{\partial L_{\text{rigid}}}{\partial \dot{e}_j(z_{j_b})} \delta \dot{e}_j(z_{j_b}) \\ & + \frac{\partial L_{\text{rigid}}}{\partial e'_j(z_{j_a})} \delta e'_j(z_{j_a}) + \frac{\partial L_{\text{rigid}}}{\partial e'_j(z_{j_b})} \delta e'_j(z_{j_b}) \\ & + \Xi_{\text{bc}3j} \delta e'_j(z_{j_b}) + \Xi_{\text{bc}4j} \delta e'_j(z_{j_a}) \\ & \left. + \frac{\partial L_{\text{rigid}}}{\partial \dot{e}'_j(z_{j_a})} \delta \dot{e}'_j(z_{j_a}) + \frac{\partial L_{\text{rigid}}}{\partial \dot{e}'_j(z_{j_b})} \delta \dot{e}'_j(z_{j_b}) \right\} dt \quad (43) \end{aligned}$$

Next, the variation is integrated by parts. The terms in the variation of time derivatives are integrated first in time. The terms in the variation of spatial derivatives are integrated first in z_j ,

$$\begin{aligned} \delta \int_{t_1}^{t_2} L dt = & \int_{t_1}^{t_2} \left\{ \sum_i \left[\sum_j \int_{z_j} \frac{\partial L_{fj}}{\partial r_i} dz_j \right. \right. \\ & + \frac{\partial L_{\text{rigid}}}{\partial r_i} - \sum_j \int_{z_j} \frac{d}{dt} \left(\frac{\partial L_{fj}}{\partial \dot{r}_i} \right) dz_j \\ & \left. - \frac{d}{dt} \left(\frac{\partial L_{\text{rigid}}}{\partial \dot{r}_i} \right) + \Xi_{\text{rigid}_i} \right] \delta r_i \\ & + \sum_j \left[\int_{z_j} \frac{\partial L_{fj}}{\partial e_j(z_j)} dz_j \right. \end{aligned}$$

$$\begin{aligned}
& - \int_{z_j} \frac{d}{dt} \left(\frac{\partial L_{fj}}{\partial \dot{e}_j(z_j)} \right) dz_j \\
& - \int_{z_j} \frac{\partial}{\partial z_j} \left(\frac{\partial L_{fj}}{\partial e'_j(z_j)} \right) dz_j \\
& + \int_{z_j} \frac{\partial^2}{\partial z_j^2} \left(\frac{\partial L_{fj}}{\partial e''_j(z_j)} \right) dz_j \\
& + \int_{z_j} \Xi_{fj} dz_j \Big] \delta e_j(z_j) \\
& + \sum_j \left[- \frac{d}{dt} \left(\frac{\partial L_{\text{rigid}}}{\partial \dot{e}_j(z_{jb})} \right) + \frac{\partial L_{\text{rigid}}}{\partial e_j(z_{jb})} \right. \\
& + \frac{\partial L_{fj}}{\partial e'_j(z_{jb})} - \frac{\partial}{\partial z_j} \left(\frac{\partial L_{fj}}{\partial e''_j(z_{jb})} \right) \\
& \quad \left. + \Xi_{bc1j} \right] \delta e_j(z_{jb}) \\
& + \sum_j \left[- \frac{d}{dt} \left(\frac{\partial L_{\text{rigid}}}{\partial \dot{e}_j(z_{ja})} \right) + \frac{\partial L_{\text{rigid}}}{\partial e_j(z_{ja})} \right. \\
& - \frac{\partial L_{fj}}{\partial e'_j(z_{ja})} + \frac{\partial}{\partial z_j} \left(\frac{\partial L_{fj}}{\partial e''_j(z_{ja})} \right) \\
& \quad \left. + \Xi_{bc2j} \right] \delta e_j(z_{ja}) \\
& + \sum_j \left[- \frac{d}{dt} \left(\frac{\partial L_{\text{rigid}}}{\partial \dot{e}'_j(z_{jb})} \right) + \frac{\partial L_{\text{rigid}}}{\partial e'_j(z_{jb})} \right. \\
& + \frac{\partial L_{fj}}{\partial e''_j(z_{jb})} + \Xi_{bc3j} \Big] \delta e'_j(z_{jb}) \\
& + \sum_j \left[- \frac{d}{dt} \left(\frac{\partial L_{\text{rigid}}}{\partial \dot{e}'_j(z_{ja})} \right) + \frac{\partial L_{\text{rigid}}}{\partial e'_j(z_{ja})} \right. \\
& \quad \left. - \frac{\partial L_{fj}}{\partial e''_j(z_{ja})} + \Xi_{bc4j} \right] \delta e'_j(z_{ja}) \Big\} dt \quad . \quad (44)
\end{aligned}$$

Note that the summation in i is for each of the rigid body equation terms; the summation over j is for the terms due to the flexible components. Now the equations of motion can be extracted from Equation 44. The first set of equations arises from setting the coefficient of each δr_i to zero,

$$\begin{aligned}
& - \sum_j \int_{z_j} \frac{\partial L_{fj}}{\partial r_i} dz_j - \frac{\partial L_{\text{rigid}}}{\partial r_i} \\
& + \sum_j \int_{z_j} \frac{d}{dt} \left(\frac{\partial L_{fj}}{\partial \dot{r}_i} \right) dz_j \\
& + \frac{d}{dt} \left(\frac{\partial L_{\text{rigid}}}{\partial \dot{r}_i} \right) = \Xi_{\text{rigid}i} \quad i = 1, 2, \dots, m \quad (45)
\end{aligned}$$

The next set of equations is derived from setting the coefficient of each $\delta e_j(z_j)$ to zero. The summation over j disappears because each term of the summation contains a different $\delta e_j(z_j)$ for any given j , and therefore, becomes a separate equation. For the integral in z_j to be zero for arbitrary variations, the integrand must be zero yielding

$$\begin{aligned}
& - \frac{\partial L_{fj}}{\partial e_j(z_j)} + \frac{d}{dt} \left(\frac{\partial L_{fj}}{\partial \dot{e}_j(z_j)} \right) + \frac{\partial}{\partial z_j} \left(\frac{\partial L_{fj}}{\partial e'_j(z_j)} \right) \\
& \quad - \frac{\partial^2}{\partial z_j^2} \left(\frac{\partial L_{fj}}{\partial e''_j(z_j)} \right) = \Xi_{fj} \quad ,
\end{aligned}$$

$$e_j(z_{ja}) < e_j(z_j) < e_j(z_{jb}) \quad j = 1, 2, \dots, n \quad . \quad (46)$$

The last four sets of equations are boundary conditions at the edges of the continuum corresponding to $e_j(z_{ja})$ and $e_j(z_{jb})$. Note that the summation over j is dropped for the same reason as in the previous equation.

$$\begin{aligned}
& \frac{d}{dt} \left(\frac{\partial L_{\text{rigid}}}{\partial \dot{e}_j(z_{jb})} \right) - \frac{\partial L_{\text{rigid}}}{\partial e_j(z_{jb})} - \frac{\partial L_{fj}}{\partial e'_j(z_{jb})} \\
& + \frac{\partial}{\partial z_j} \left(\frac{\partial L_{fj}}{\partial e''_j(z_{jb})} \right) = \Xi_{bc1j} \quad j = 1, 2, \dots, n \quad (47)
\end{aligned}$$

$$\begin{aligned}
& \frac{d}{dt} \left(\frac{\partial L_{\text{rigid}}}{\partial \dot{e}_j(z_{ja})} \right) - \frac{\partial L_{\text{rigid}}}{\partial e_j(z_{ja})} + \frac{\partial L_{fj}}{\partial e'_j(z_{ja})} \\
& - \frac{\partial}{\partial z_j} \left(\frac{\partial L_{fj}}{\partial e''_j(z_{ja})} \right) = \Xi_{bc2j} \quad j = 1, 2, \dots, n \quad (48)
\end{aligned}$$

$$\begin{aligned}
& \frac{d}{dt} \left(\frac{\partial L_{\text{rigid}}}{\partial \dot{e}'_j(z_{jb})} \right) - \frac{\partial L_{\text{rigid}}}{\partial e'_j(z_{jb})} \\
& - \frac{\partial L_{fj}}{\partial e''_j(z_{jb})} = \Xi_{bc3j} \quad j = 1, 2, \dots, n \quad (49)
\end{aligned}$$

$$\begin{aligned}
& \frac{d}{dt} \left(\frac{\partial L_{\text{rigid}}}{\partial \dot{e}'_j(z_{ja})} \right) - \frac{\partial L_{\text{rigid}}}{\partial e'_j(z_{ja})} \\
& + \frac{\partial L_{fj}}{\partial e''_j(z_{ja})} = \Xi_{bc4j} \quad j = 1, 2, \dots, n \quad (50)
\end{aligned}$$

In total there are m rigid body equations, n flexible component equations, and $4n$ boundary equations.

7.2 The Surrogate Element Method

The equation derivation presented above is now performed with the same notation but using the surrogate element method outlined in this paper. The Lagrangian for this case is

$$L_s = \sum_{j=1}^n \sum_{z_j} L_{fj} \Delta z_j + L_{\text{rigid}} \quad (51)$$

with terms as defined in Equations 39 and 40. The Lagrangian is formed from the equivalent rigid-particle surrogate element model. Equation 10 is applied to the Lagrangian,

$$\begin{aligned}
& \frac{\partial}{\partial t} \left(\frac{\partial L_s}{\partial \dot{\xi}_k} \right) - \frac{\partial L_s}{\partial \xi_k} + \frac{\partial}{\partial z_j} \left(\frac{\partial L_s}{\partial \left(\frac{\partial \xi_k}{\partial z_j} \right)} \right) \\
& - \frac{\partial^2}{\partial z_j^2} \left(\frac{\partial L_s}{\partial \left(\frac{\partial^2 \xi_k}{\partial z_j^2} \right)} \right) = {}^s \Xi_k \quad k = 1, 2, \dots, p \quad . \quad (52)
\end{aligned}$$

The first m of the ξ_k correspond to coordinates r_i above; the next n of the ξ_k correspond to coordinates $e_j(z_j)$; the last $4n$ of the ξ_k correspond to coordinates $e_j(z_{j_a})$, $e_j(z_{j_b})$, $e'_j(z_{j_a})$, and $e'_j(z_{j_b})$ respectively. Therefore, $p = m + 5n$, and $j = k - m$ so that the z_j refer to the spatial variables along the continuum corresponding to ξ_k . The ${}^s\Xi_k$ are the generalized forces defined in terms of the generalized forces from the variational approach given by

$${}^s\Xi_k = \begin{cases} \Xi_{\text{rigid}k} & \text{for } k = 1, 2, \dots, m \\ \Xi_{\text{f}(k-m)} & \text{for } k = m+1, m+2, \dots, m+n \\ \Xi_{\text{bc}1(k-m-n)} + \Xi_{\text{table}k} & \text{for } k = m+n+1, m+n+2, \dots, m+2n \\ \Xi_{\text{bc}2(k-m-2n)} + \Xi_{\text{table}k} & \text{for } k = m+2n+1, m+2n+2, \dots, m+3n \\ \Xi_{\text{bc}3(k-m-3n)} + \Xi_{\text{table}k} & \text{for } k = m+3n+1, m+3n+2, \dots, m+4n \\ \Xi_{\text{bc}4(k-m-4n)} + \Xi_{\text{table}k} & \text{for } k = m+4n+1, m+4n+2, \dots, m+5n \end{cases} \quad (53)$$

where the $\Xi_{\text{table}k}$ are obtained from Table 1 and can only be non-zero for coordinates at the boundaries of the continua.

The ξ_k correspond to three different variable types; the rigid body coordinates, the continuous coordinates, and the continuous coordinates at the boundaries. The evaluation of Equation 52 is treated separately for each case. For $k = 1, 2, \dots, m$, Equation 52 becomes,

$$\begin{aligned} & - \sum_j \sum_{\Delta z_j} \frac{\partial L_{\text{f}j}}{\partial r_i} \Delta z_j - \frac{\partial L_{\text{rigid}}}{\partial r_i} \\ & + \sum_j \sum_{\Delta z_j} \frac{d}{dt} \left(\frac{\partial L_{\text{f}j}}{\partial \dot{r}_i} \right) \Delta z_j \\ & + \frac{d}{dt} \left(\frac{\partial L_{\text{rigid}}}{\partial \dot{r}_i} \right) = \Xi_{\text{rigid}i} \quad i = 1, 2, \dots, m \end{aligned} \quad (54)$$

The third and fourth terms in Equation 52 are zero because the ξ_k are rigid coordinates.

For $k = m+1, m+2, \dots, m+n$, Equation 52 becomes,

$$\begin{aligned} & - \frac{\partial L_{\text{f}j}}{\partial e_j(z_j)} \Delta z_j + \frac{d}{dt} \left(\frac{\partial L_{\text{f}j}}{\partial \dot{e}_j(z_j)} \right) \Delta z_j \\ & + \frac{\partial}{\partial z_j} \left(\frac{\partial L_{\text{f}j}}{\partial e'_j(z_j)} \right) \Delta z_j - \frac{\partial^2}{\partial z_j^2} \left(\frac{\partial L_{\text{f}j}}{\partial e''_j(z_j)} \right) \Delta z_j \\ & = \Xi_{\text{f}j} \Delta z_j \quad j = 1, 2, \dots, n \end{aligned} \quad (55)$$

For $k = m+n+1, m+n+2, \dots, m+5n$, Equation 52

becomes,

$$\frac{d}{dt} \left(\frac{\partial L_{\text{rigid}}}{\partial \dot{e}_j(z_{j_b})} \right) - \frac{\partial L_{\text{rigid}}}{\partial e_j(z_{j_b})} = \Xi_{\text{bc}1j} + F_{1j} \quad j = 1, 2, \dots, n \quad (56)$$

$$\frac{d}{dt} \left(\frac{\partial L_{\text{rigid}}}{\partial \dot{e}_j(z_{j_a})} \right) - \frac{\partial L_{\text{rigid}}}{\partial e_j(z_{j_a})} = \Xi_{\text{bc}2j} + F_{2j} \quad j = 1, 2, \dots, n \quad (57)$$

$$\frac{d}{dt} \left(\frac{\partial L_{\text{rigid}}}{\partial \dot{e}'_j(z_{j_b})} \right) - \frac{\partial L_{\text{rigid}}}{\partial e'_j(z_{j_b})} = \Xi_{\text{bc}3j} + M_{1j} \quad j = 1, 2, \dots, n \quad (58)$$

$$\frac{d}{dt} \left(\frac{\partial L_{\text{rigid}}}{\partial \dot{e}''_j(z_{j_a})} \right) - \frac{\partial L_{\text{rigid}}}{\partial e''_j(z_{j_a})} = \Xi_{\text{bc}4j} + M_{2j} \quad j = 1, 2, \dots, n \quad (59)$$

where the F_{1j} , F_{2j} , M_{1j} , and M_{2j} are obtained from Table 1. The Table defines these values as the forces and moments acting from the continuum onto the adjacent components. The values used in creating the table are given by

$$F_1 = \frac{\partial L_{\text{f}j}}{\partial e'_j(z_{j_b})} - \frac{\partial}{\partial z_j} \left(\frac{\partial L_{\text{f}j}}{\partial e''_j(z_{j_b})} \right) \quad (60)$$

$$F_2 = - \frac{\partial L_{\text{f}j}}{\partial e'_j(z_{j_a})} + \frac{\partial}{\partial z_j} \left(\frac{\partial L_{\text{f}j}}{\partial e''_j(z_{j_a})} \right) \quad (61)$$

$$M_1 = \frac{\partial L_{\text{f}j}}{\partial e''_j(z_{j_b})} \quad (62)$$

$$M_2 = - \frac{\partial L_{\text{f}j}}{\partial e''_j(z_{j_a})} \quad (63)$$

Following the procedure presented in Section 4, Δz_j is canceled from every term of Equation 55 to yield Equation 46. Next, all terms in Δz_j that remain in any of the equations are integrated along the z_j . These terms are all found in Equation 54. The integration yields Equation 45. Finally, Equations 56–59 can be rewritten with substitutions from Table 1 for the F_1 , F_2 , M_1 , and M_2 to obtain Equations 47–50.

8 Appendix B

The surrogate element derivation above assumed that the coordinate describing the location of the representative particle in a continuum be geometrically compatible with the coordinates for adjacent elements at the boundaries of that continuum. Geometric compatibility means that the variation of the surrogate element coordinates and the variation of the boundary coordinates be equal. Consider the example shown in Figure 4. Coordinate r_2 at $x = 0$ equals r_1 , and r_2 at $x = l$ equals r_3 . However, q_2 at $x = 0$ is equal to zero, and q_3 equals the sum of q_1 plus q_2 at $x = l$. The method outlined above assumes that the consistent coordinate set (r_1, r_2, r_3) be chosen. The requirement on the coordinate selection,

$$\delta r_2|_{x=0} = \delta r_1 \quad (64)$$

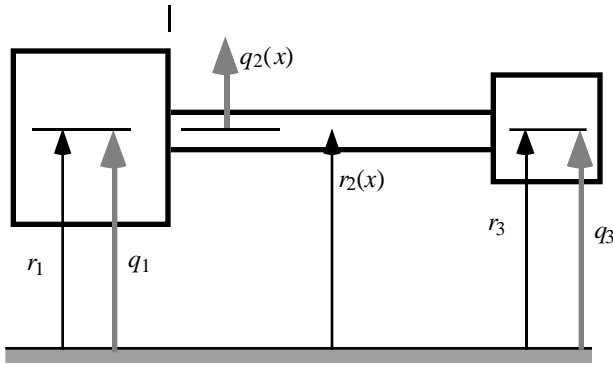

Figure 4: Example using coordinates with different reference frames. The r_1, r_2, r_3 frame is referenced to ground. The q_1 and q_3 are referenced to ground while q_2 is referenced to the left hand mass.

and

$$\delta r_2|_{x=l} = \delta r_3 \quad (65)$$

is satisfied. The force terms on the end of the continuum are multiplied by the variations of the coordinates at those boundaries ($\delta r_2|_{x=0}$ and $\delta r_2|_{x=l}$ in this example). The force terms acting on the rigid components are multiplied by the variations of the rigid component coordinates (δr_1 and δr_3 in this example). The method outlined above implicitly equates these two sets of forces. However, if the two sets of variations are not equal for the chosen coordinate system, then the equating of these force terms can not be justified.

The requirement discussed above can be relaxed by realizing that the force terms can be corrected when using a selection of coordinates that is not geometrically compatible. In the example above using the q_1, q_2, q_3 system, $\delta q_2|_{x=0} = 0$. The force term F_1 , which would be applied to the mass on the left when using a geometrically compatible coordinate system, is not added to ${}^s\Xi_1$. Also, $\delta q_2|_{x=l} = \delta q_3 - \delta q_1$. Therefore, for Lagrange's method to provide correct equations of motion, F_2 , the force at the right end of the beam must be added to the generalized force term for the q_3 equation (${}^s\Xi_3$), and subtracted from the generalized force term for the q_1 equation (${}^s\Xi_1$). This modification is convenient when applying the surrogate element method to more complex systems such as those with rotating flexible components.

References

- [Blevins 79] **Blevins, Robert D.**, *Formulas for Natural Frequency and Mode Shape*, Van Nostrand Reinhold Company, New York, 1979.
- [Crandall 82] **Crandall, Stephen H.; Karnopp, Dean C.; Kurtz, Edward F., Jr.; and Pridmore-Brown, David C.**, *Dynamics of Mechanical and Electromechanical Systems*, Robert E. Krieger Publishing Company, Malabar, Florida, 1982. pp 332–351.
- [Kane 85] **Kane, Thomas R.; and Levinson, David A.**, *Dynamics: Theory and Applications*, McGraw-Hill, Inc., New York, 1985.

- [Low 88] **Low, K. H.; and Vidyasagar, M.**, "A Lagrangian Formulation of the Dynamic Model for Flexible Manipulator Systems.", *Journal of Dynamic Systems, Measurement, and Control*, June, 1988. Vol. 110, pp 175–181.
- [Lanczos 70] **Lanczos, Cornelius**, *The Variational Principles of Mechanics*, University of Toronto Press, Toronto, 1949. Reprinted by Dover Publications, 1970. pp 35–72.
- [Meirovitch 90] **Meirovitch, Leonard**, *Dynamics and Control of Structures*, John Wiley and Sons, New York, 1990. pp 270-1.
- [Singer 92] **Singer, Neil C.; and Seering, Warren P.**, "Two Extensions To Kane's Method For Simplifying Equation Derivation.", Accepted for publication in the *Journal of the Astronautical Sciences*, April 1993.