

The Lean Aircraft Initiative
Report Series
#RP96-07-28
November 1996

Understanding Lean Manufacturing According to Axiomatic Design Principles

Prepared by: Vicente A. Reynal and David S. Cochran

Lean Aircraft Initiative
Center for Technology, Policy, and Industrial Development
Massachusetts Institute of Technology
Massachusetts Avenue • Room 33-407
Cambridge, MA 02139

The authors acknowledge the financial support for this research made available by the Lean Aircraft Initiative at MIT sponsored jointly by the US Air Force and a consortium of aerospace companies. All facts, statements, opinions, and conclusions expressed herein are solely those of the authors and do not in any way reflect those of the Lean Aircraft Initiative, the US Air Force, the sponsoring companies and organizations (individually or as a group), or MIT. The latter are absolved from any remaining errors or shortcomings for which the authors take full responsibility.

© Massachusetts Institute of Technology, 1996

ABSTRACT

The design and evaluation of manufacturing system design is the subject of this paper. Though much attention has been given to the design of manufacturing systems, in practice most efforts still remain empirically-based. Numerous idioms have been used in the attempt to describe the operation of manufacturing systems. When a company tries to become "lean" or wants to increase the production and become more efficient, the company will start to introduce numerous concepts developed by Toyota and others. The problem is that a company does not know the order in which to implement the lean changes or why they should implement what they are implementing. This approach greatly slows manufacturing improvements when complementary or contradictive concepts are introduced on an ad-hoc basis. In this paper, a sequence of implementation steps will be developed through the application of axiomatic design. This sequence will provide a design methodology for lean production which connects manufacturing system design objectives to operation design parameters. This paper will use the methodology developed to improve manufacturing processes in two different companies.

Keywords: Manufacturing systems; Design Theory, Lean Manufacturing; Process Improvement; Cellular Manufacturing

Introduction

Though much attention has been given to the design of manufacturing systems, in practice most efforts still remain empirically-based. This is surprising given the substantial capital investment required for new manufacturing systems. There is basically no consensus on the right approach to design the most efficient and the most effective manufacturing system. For this reason, when a company wants to become "lean" or

VICENTE A REYNAL is a Graduate Research Assistant at Massachusetts Institute of Technology (MIT). He is a candidate for a Master of Science in Mechanical Engineering and a Master of Science in Technology and Policy.

DAVID S. COCHRAN is an Assistant Professor in the Department of Mechanical Engineering at Massachusetts Institute of Technology (MIT). He is the Director of the Lean Production Laboratory at MIT. His areas of study are the control and design of manufacturing systems.

Address reprint request to David S Cochran and/or Vicente A Reynal, 77 Massachusetts Ave., Room 35-229, Cambridge, MA, 02139 USA. Phone: +1 (617) 253 6769; Fax: +1 (617) 253 2123; email: dcochran@mit.edu, reynal@mit.edu

wants to increase the production and become more efficient, the company will introduce numerous concepts developed by Toyota and others. The problem is that companies do not know the order in which to implement the lean changes. In addition, the cause and effect relationship of lean practice implementation is not well understood. The result is that companies do not know why they are implementing certain practices. This approach greatly slows manufacturing improvements when lean practices are introduced on an ad-hoc basis. Without a fundamental understanding of key manufacturing principles, progress towards an optimal manufacturing paradigm will be highly iterative and subjective.

The increasing necessity for more efficient and competent manufacturing systems, which simultaneously producing a low cost and high quality product when the customer demands it, are the central drivers for the continual survival of manufacturing organizations today. Like design in any discipline, if the fundamental nature of the design is unsound, only limited improvements can be made. In manufacturing systems this means that the possibility of arriving to a highly integrated and well rounded manufacturing system is rather remote. The goal is to make the total productivity greater than the sum of the parts.

Overview

In this paper, axiomatic design will be used to help the authors redesign the assembly area of a Boston Area Manufacturing Company (Company VRA). The sequence of implementation steps developed through application of axiomatic design will then be adopted as the infrastructure to create a more lean production system. The

methodology will then be used to improve an existing cell in another company (Company XYZ) and will show that even though this second company (XYZ) thought they had achieved an optimal cell design, we will see that they only performed one step of the lean manufacturing methodology presented in this paper. The authors will use the axiomatic design methodology in order to improve the existing process. This methodology will create a better manufacturing design, which will lead to a better and highly integrated manufacturing system. Not only will this methodology be used to improve two manufacturing processes, but also will show why, when and how several "practices" described for implementing "lean" manufacturing systems should be applied.

Key Concepts of Axiomatic Design

Axiomatic Design defines design as the creation of synthesized solutions in the form of products, processes or systems that satisfy perceived needs through mapping between functional requirements (FRs) and design parameters (DPs) [1]. The Functional Requirements (FRs) represent the goals of the design or what we want to achieve. FRs are defined in the functional domain in order to satisfy the needs, which are defined in the customer domain. The Design Parameters (DPs) express how we want to satisfy the functional requirement. DPs are created in the physical domain to satisfy the FRs. The domains are shown in Figure 1. The customer domain is where the customer needs reside. These needs must be mapped to the functional domain where the customer needs are translated into a set of functional requirements (FRs). Not only will Functional Requirements be defined for the new design, but also constraints will appear as a result of translating customer wants to FRs. Constraints have to be obeyed during the entire

design process. They refer to FRs, as well as to DPs and PVs. This fact is indicated in Figure 1 by placing the constraints above the functional, physical and process domain. The FRs are then mapped to the physical domain and the DPs are mapped to the process domain in terms of process variables (PVs).

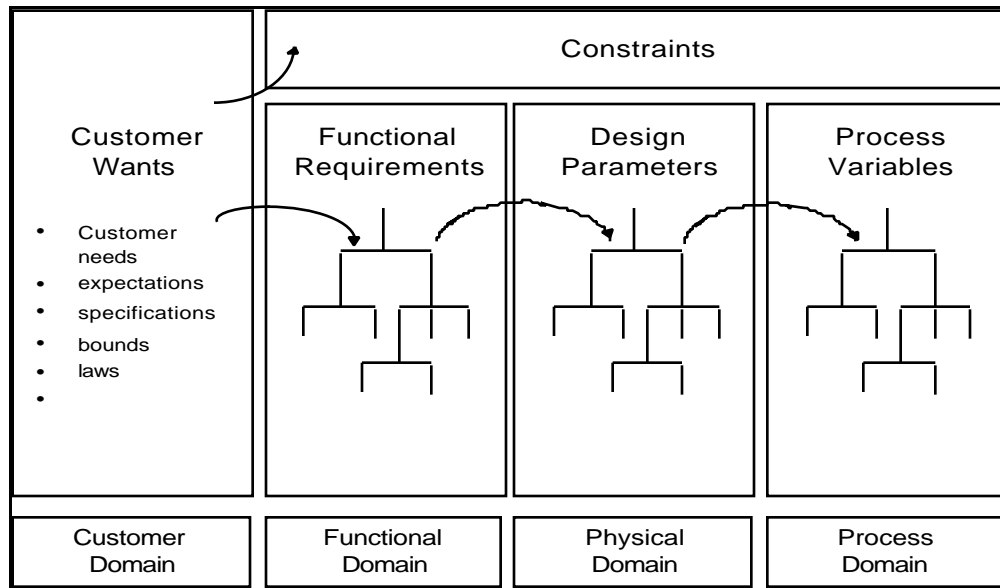

Figure 1: All designs can be represented in four domains [1]

In most design tasks, it is necessary to decompose the problem. Figure 2 indicates hierarchies in the functional, physical and process domain. The development of the hierarchy will be done by zigzagging between the domains. The zigzagging takes place between two domains. After defining the FR of the top level a design concept has to be generated. This results in the mapping process as shown in Figure 2. The authors believe that for the design of manufacturing systems only the Functional and Physical Domains are needed.

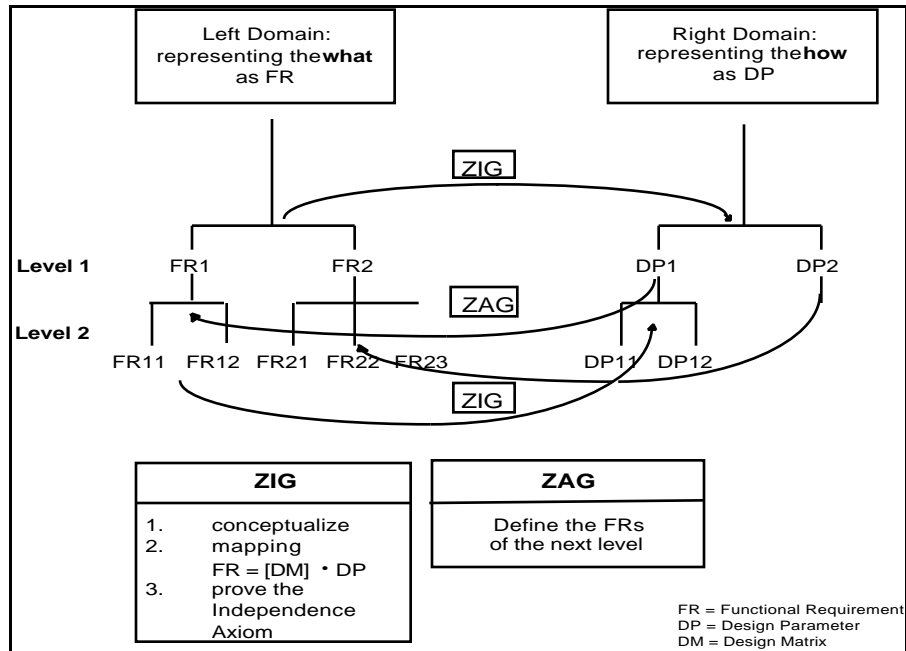

Figure 2: Zigzagging between the domains to developed the hierarchy

In order for this mapping to be satisfied, two axioms must be followed [1]:

Axiom 1: The Independence Axiom

Maintain the Independence of the FRs

Axiom 2: The Information Axiom

Minimize the Information Content of the design

The FRs and DPs are described mathematically as a vector. The Design Matrix (DM) describes the relationship between FRs and DPs.

$$\{\text{FRs}\} = [\text{DM}]\{\text{DPs}\} \quad (1)$$

An element in the design matrix DM_{ij} is given by

$$DM_{ij} = \frac{FR_i}{DP_j} \quad (2)$$

which is a constant in linear design. In order to satisfy the Independence Axiom, [DM] must be a diagonal or triangular matrix. The design with a diagonal matrix is called an uncoupled design and a design with a triangular matrix is called a decoupled design.

Decoupled designs satisfy the Independence Axiom provided that the DPs are implemented or set in a specific sequence. All other designs are coupled.

The second axiom (information axiom) is defined in terms of the probability of successfully achieving FRs or DPs. The information is defined as:

$$I = \sum_{i=1}^n \log_2 \frac{1}{p_i} \quad (3)$$

where p_i is the probability of DP_j satisfying FR_i and \log is either the logarithm of base 2 (with the units on bits) or the natural logarithm (with the units in nats). Since there are n FRs the total information content is the sum of the probabilities. The Information Axiom states that the design with the smallest I is the best design, since it requires the least amount of information to achieve the functional requirements of the design.

Companies studied

Two different manufacturing plants were studied. For the first plant, VRA, an assembly area was redesigned in order to increase production and to meet other requirements established by management to improve customer responsiveness and reduce product delivery lead time. The second company studied, which in this paper will be referred to as XYZ, is a manufacturer of power tools. The area studied in this company was the machining area, specifically a cell that is producing one of the most common products that this company manufactures.

Background of Company VRA

The first case study discussed in this paper took place at a company located in the Boston Area between March and May 1996. The company, which will be referred to

as VRA, manufactures optical tables and vibration isolation equipment to be used in precision laboratories.

The main reason for VRA to change was due to a new product that will be launched during Fall 1996. For this new design, VRA wanted to introduce a new very large optical table. This table required new machines, new equipment and space for translating the table from one operation to the other. Furthermore, there were some problems in the control and design of the assembly area in the plant.

The major concerns of the managers about the existing plant were three fold:

1. unpredictable lead times
2. inconsistency in the material flow
3. inconsistency in the flow of information.

These problems created long lead times, high inventory, quality problems and many others.

VRA produces a wide range of product dealing with optical tables, but about ninety percent of what is produced in this company can be divided into three major categories:

- Workstations
- Individual Mounts
- Platforms

The main and most important feature in all the products mentioned is that they contain an automatic height control leveling system. This leveling system is composed of a servo valve system that feeds air from a pressurized air source or bleeds air from the legs, so that the isolated tabletop is conveniently maintained at a preset deflection level independent of load addition or removal. Precision can be obtained in the range of

± 0.015 " to ± 0.0025 " depending on the valve type. The most common isolation mount or system is composed of a valve (two types: delco and arm valves), a drop air mount, and a regulator.

Background of Company XYZ

Company XYZ is also located in the Boston Area. The Company manufactures power tools with sales of over \$50 million per year with approximately 100 employees. For one of their newest products, they were experiencing such an increase in demand that they could not produce more products than they were selling. Deliveries were not on time and they started to lose customers due to this situation. At Company XYZ, an existing machining cell was studied and improved in order to meet customer demand.

Axiomatic Design for Process Improvement Methodology

In order to meet the concerns of management and to meet customer demand, the goals for redesigning the assembly and machining area were the following:

1. Decrease Work In Process and Finished Goods Inventory.
2. Reduce Customer Order Lead Time.
3. Produce only what it is needed when it is needed.

STEP 1: High Level of FRs and DPs

The goals mentioned above will bring most of the benefits to this company. Therefore, when redesigning the manufacturing system, these customer wants will lead to the high level functional requirements for improving the assembly and machining area:

FR1: Create a Predictable Output

FR2: Create Continuous Flow

FR3: Produce what is needed, when it is needed (JIT)

The design parameters mapped by functional requirements are:

DP1: Standardized Work

DP2: Connect Processes with same volume requirements

DP3: Create a Pull System

The design equation is represented as:

$$\begin{array}{rcccc}
 \text{FR1} & & \text{X} & \text{X} & 0 & \text{DP1} \\
 \text{FR2} & = & 0 & \text{X} & 0 & \cdot \text{DP2} \\
 \text{FR3} & & \text{X} & \text{X} & \text{X} & \text{DP3}
 \end{array}$$

where X represents a non zero element, and 0 represents a zero element. From the matrix above it can be seen that by starting with standardized work and then following it with a continuous flow is not the most efficient sequence to follow. If a process or work is standardized and then the layout is changed to a continuous flow, the operations and process will need to be standardized again due to this change [2]. For example VRA tried to standardize the assembly of the valves before implementing a continuous flow. The result is that the operators never followed the sequence implemented by the engineering department. The main problem was that the engineering department designed a standard procedure to follow; however in the assembly area there was no physical location or tools available to follow the determined sequence. Having this concept in mind, the most efficient implementation sequence can be determined with the help of axiomatic design. Rearranging the previous design matrix, we obtain the following:

$$\begin{array}{rcccc}
 \text{FR2} & & \text{X} & 0 & 0 & \text{DP2} \\
 \text{FR1} & = & \text{X} & \text{X} & 0 & \text{DP1} \\
 \text{FR3} & & \text{X} & \text{X} & \text{X} & \text{DP3}
 \end{array} \quad (4)$$

The design equations for the above matrix are:

$$\text{FR2} = \text{A11} * \text{DP2}$$

$$\text{FR1} = \text{A21} * \text{DP1} + \text{A22} * \text{DP2}$$

$$\text{FR3} = \text{A31} * \text{DP1} + \text{A32} * \text{DP2} + \text{A33} * \text{DP3}$$

This design matrix is called "decoupled" meaning that the matrix is triangular. Decoupled designs are path dependent. In other words, to get the best results the following sequence must be followed:

1. Connect Process with same volume requirements
2. Standardize Work with Consistent Cycle Time
3. Create a Pull System

The pull system links production between the assembly, machining and purchasing areas. The "pull system" controls the machine start time mentioned by DP3. These are the major areas within a manufacturing system that can be turned into a pull type production environment. To achieve this DP, we also need to follow a sequence in order to improve the process. This sequence as shown in Figure 3, is to first convert the assembly area to a pull production, then the machining process and lastly the purchasing or supplier leg of the production chain.

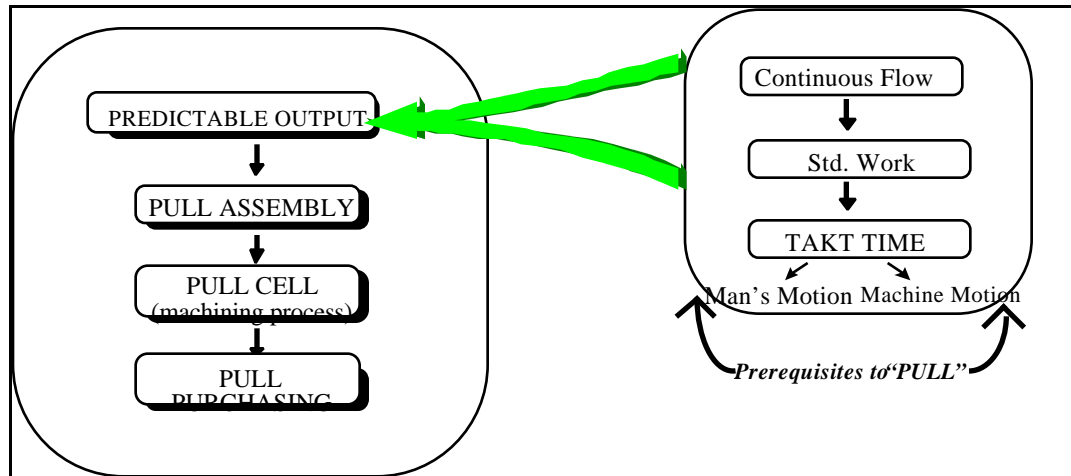

Figure 3: Sequence to follow in order to design or improve a process for Lean Production

STEP 2: Decomposing FRs and DPs (second level)

Since the design solution can not be finalized or completed by the selected set of DPs at the highest level, the FRs need to be decomposed further. This decomposition is done in parallel with the zigzagging between the FRs and DPs.

FR2 (Create Continuous Flow) is the first FR to be done in order to improve a process, therefore it will be decomposed first to determine what the functional requirements are for a continuous flow.

FR2: Create a Continuous Flow

FR21: “Jidoka”: Separate Machine’s Work from Operator’s Work
(Operator can use more than one machine)

FR22: Manpower Flexibility

FR23: Reduce Inventory between operations/machine

The same is done with FR1 and FR3:

FR1: Create a Predictable Output

FR11: Identify production rate

FR12: Determine number of operators

FR13: Determine sequence each worker will work within takt time frame

FR3: *Create a Pull System***FR31:** Control Start Time of Machine/Cell**FR32:** Make a Consistent Quantity

By doing the zigzagging between FRs and DPs, as done on the first level, the DPs for the second level corresponding to FR2 were identified in order to maximize independence.

DP2: *Connect Processes with same volume requirements***DP21:** Multi-functional worker**DP22:** "U" shaped layout of machines**DP23:** Units from one operation to the next 1 by 1

FR21 captures the importance of cross training employees in a manufacturing process. FR21 is of considerable significance in the area of cellular manufacturing. The second requirement, manpower flexibility, means that in the new, redesigned area, it is desired that the number of operators working in one product family or cell can fluctuate depending on the demand. This is very important in order to keep costs down, when no more than one operator is needed (low demand). When demand increases, operators are added to the process. The design parameter for the mentioned FR was chosen to be "U shaped layout of machines" because it is the most efficient way to create flexibility not only in the worker but also in the number of workers allocated to a cell. One example of this is shown in the next figure (Figure 4), where only one operator is used when the demand is low, but when demand increases another operator can be brought to the cell in order to meet the specified takt time ($\text{takt time} = \frac{\text{available operating hours}}{\text{customer demand}}$).

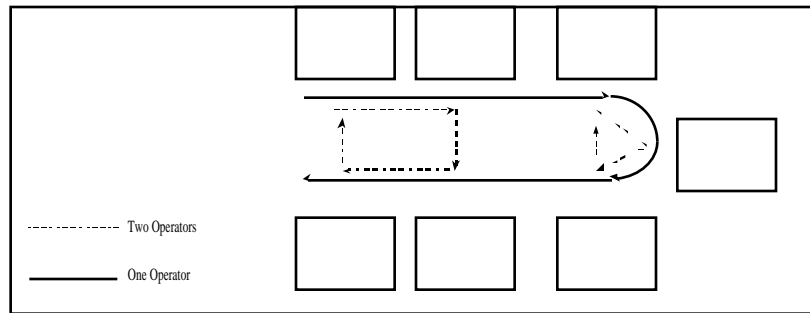

Figure 4: Manpower Flexibility

The design matrix that will describe FRs referring to FR2 and DPs relating to DP2 is the following

$$\begin{array}{rcccc}
 \text{FR21} & \text{X} & 0 & 0 & \text{DP21} \\
 \text{FR22} & = & \text{X} & \text{X} & 0 \cdot \text{DP22} \\
 \text{FR23} & & 0 & 0 & \text{X} \text{ DP23}
 \end{array}$$

The design matrix at this level is also a decoupled design. As seen from the matrix, in order to meet FR22, DP21 and DP22 need to be implemented. This is due to the fact that it will be a more efficient cell if the operator knows how to operate all the different machines. The optimum will be to train the operator before he/she goes to work on the cell. Not only on the new machines, but also on how to work in a cellular manufacturing environment in which employees within a cell need to work as a team. This is an obvious characteristic, but most of the time a company develops a cell or improves the process, but no training is given to the operator before working in a cell. Training is necessary since working in a cellular manufacturing environment is totally new for him/her.

The effective design parameters (DPs) for **FR11**, **FR12** and **FR13** are the following:

DP11: Determine Takt Time

DP12: Manual Time required to produce one part divided by the takt time

DP13: Create standardized operation routine worksheet

The design matrix for this DPs and the respective FRs is the following:

$$\begin{array}{rcl}
 \text{FR11} & \text{X} & 0 \quad 0 \quad \text{DP11} \\
 \text{FR12} & = & \text{X} \quad \text{X} \quad 0 \quad \text{DP12} \\
 \text{FR13} & & \text{X} \quad \text{X} \quad \text{X} \quad \text{DP13}
 \end{array}$$

The figure below is an example of a standardized operation routine worksheet to define the actions of the operator under single piece flow in a cellular manufacturing system. The solid horizontal line represents the manual time of the operator (i.e. load and unload of part to be produced). The dotted horizontal line denotes the machining time for the respective machines, and the solid diagonal line is the walking time that it takes the operator to go from one machine to the other.

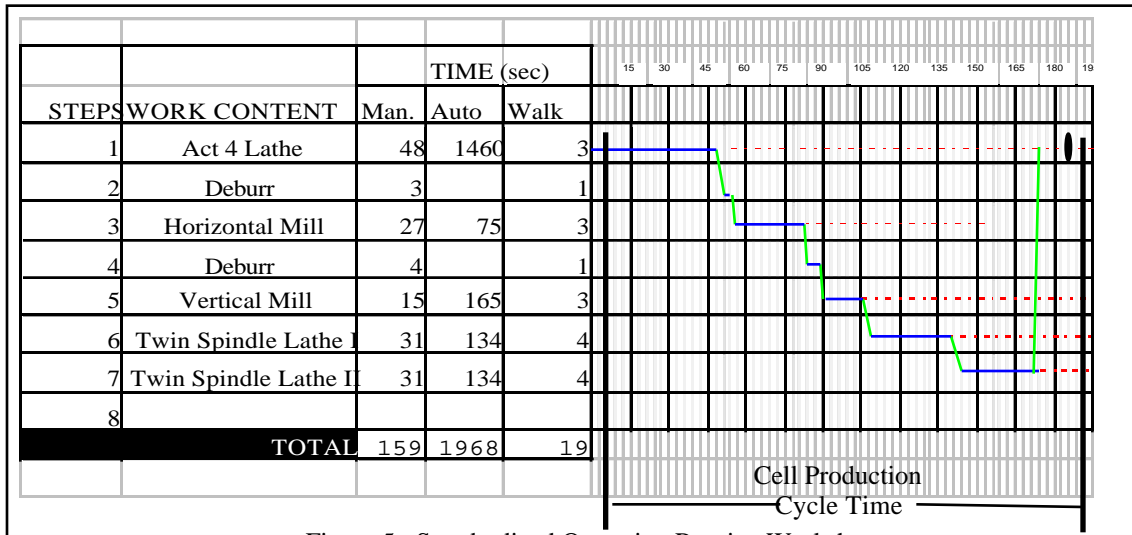

Figure 5: Standardized Operation Routine Worksheet

The next step in improving a process, stated as the last functional requirement (“FR3: Produce what it is needed and when it is needed”) is done after a continuous flow has been created and after the work has been standardized. As mentioned earlier (Figure 3), in order to create a pull system (produce the right quantity at the right time) across the manufacturing plant, first the assembly needs to be converted into a "pull assembly". Once done, the machining area and the purchasing department are converted. The first

two steps affect only internal operations but the last will involve the suppliers in order to integrate their production in synchronization with the customer plant. This is sometimes called supply chain management. Before performing the pull system within an area the other two functional requirements (FR1: Create a Predictable Output and FR2: Create a Continuous Flow) need to be done first. In other words, when rearranging an assembly area the steps will be 1.continuous flow, 2.standardized work and 3.pull assembly (produce right quantity at the right time). When moving on to the machining area, the same three steps will be performed, except that the last step will be “pull machining”.

Effective DPs to implement **FR31** and **FR32** may be selected as

DP31: Time of Kanban Card Arrival

DP32: Kanban Quantity

The design matrix is uncoupled as shown:

$$\begin{array}{ccc} \text{FR31} & \text{X} & 0 \\ \text{FR32} & 0 & \text{X} \end{array} = \begin{array}{c} \text{DP31} \\ \text{DP32} \end{array}$$

This design matrix illustrates uncoupled design that autonomously controls the parameters of production time and quantity in manufacturing systems. Figure 6 represents the three different types of cards to implement the pull production system supply chain.

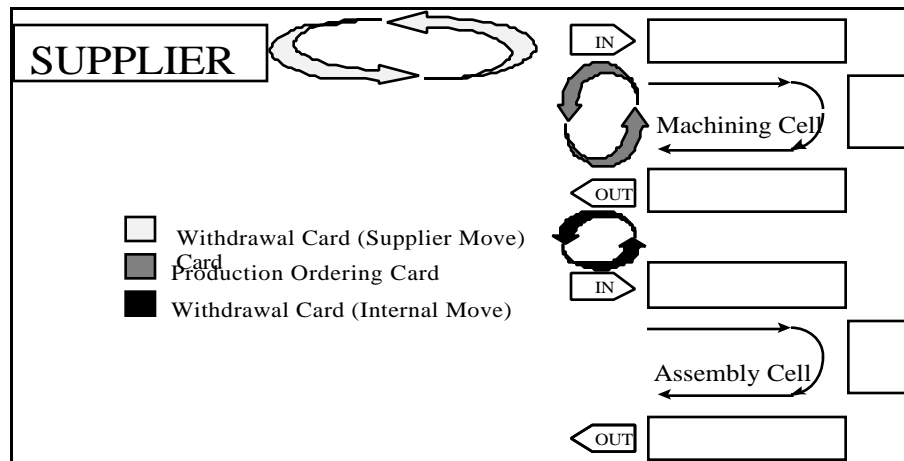

Figure 6: Production Controller Cards to be used in the Floor

Step 3: Decomposing second level to third and fourth levels of FRs and DPs

FR13 defines the work sequence each worker is required to follow, subject to constraint in cost. This constraint means that manufacturing cells no longer tie one operator to one machine. In other words, cost is controlled by most effectively allocating the proper number of workers per area. This allocation enables developed countries with higher labor costs to remain competitive in the world market place. The only way this can be done is through the improvement of existing operations in order to eliminate all the non-value added operations. With this design objective in mind, FR13 is decomposed further. The functional requirement under FR13 is

FR131: Reduction of Man-hours

and the respective DP will be

DP131: Improve Operations

This FR needs to be decomposed even further in order to find out what the necessary procedures are to be able to reduce man-hours in the company.

FR131: Reduce Manual Operation Time

FR132: Reduce Worker's Movement [3]

FR133: Reduce Machine Cycle Time

It may seem that FR131 and FR132 are the same, but a distinction needs to be made between each FR, in order to improve the operations or process.

FR131, "Reduce Manual Operation Time" is capturing all those operations that even though there is no added value to them, they must be done under the prevailing working conditions [4]. Some examples of this situation include walking to another location to retrieve parts, or walking to another room to get the necessary tools [5].

FR132 refers to unnecessary operations which can be eliminated. For example, transporting the final product to a place other than the final destination, having to walk around from table to table or from machine to machine in order to find a spot to work in order to produce a part, stockpiling intermediate products, changing hands to pick up parts, etc. This FR establishes the connection to the field of ergonomics and workplace organization.

FR133 applies to machine design for manufacturing systems. The machine design DPs are:

DP131: Eliminate operations without added value

DP132: Eliminate wasted movement

DP133: Eliminate non value added machining time

The design matrix is uncoupled as shown:

FR131	X	0	0	DP131
FR132	= 0	X	0	• DP132
FR133	0	0	X	DP133

The elimination of operator's movement can also be decomposed even further to determine two types of movements that are important to be analyzed. These two FRs are:

FR1321: Reduce Walking time

FR1322: Reduce Material Handling Time

The desired design parameters that satisfy FR1321 and FR1322 are the following:

DP1321: Move Machines/Stations Closer

DP1322: Place Material to be used at Point of Use

These types of improvements, in which wasted movements and non value added work is eliminated and a better ergonomic design is achieved is referred to by Toyota as “Kaizen events” [6]. The goal is not to fire or lay off anybody, but to decrease the production cost through the elimination of non-value added time and waste.

In order to determine when to start production within a cell or assembly area, we need some type of triggering system that allows the operator to produce the needed parts. In order to determine the required system, FR31 "Control Start Time of Machine/Cell", is decomposed to a lower level.

FR311: Authorize the production of a standard container of parts

FR312: Authorize preceding cell to replenish demanding cell

FR313: Authorize supplier's cell to replenish customer plant's cell

The respective design parameters are the following :

DP31: Production Card

DP32: Internal Move Card

DP33: Supplier Card

The FRs and DPs developed in this paper for designing manufacturing systems process improvement are summarized in Table 2. FRs and DPs are indented every time a design decomposition occurs to show the decomposition to lower levels of functional requirements and design parameters.

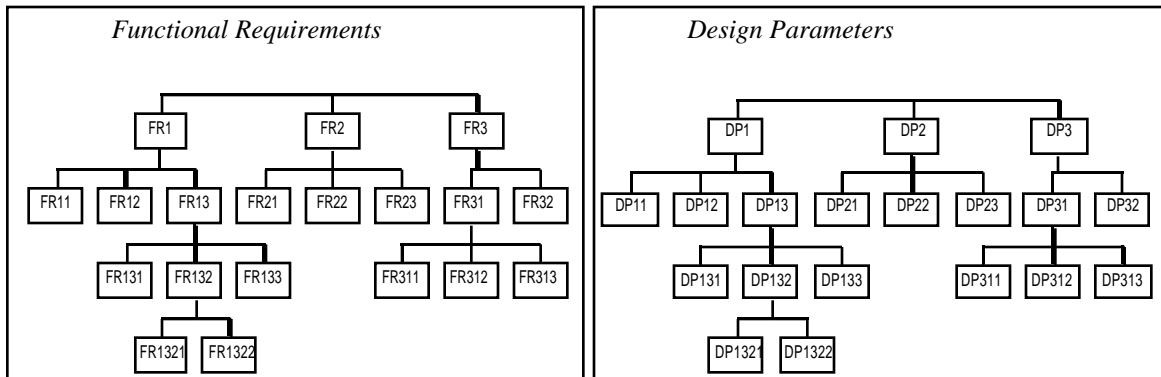

Figure 7: Tree diagram for FRs and DPs

FR1	Create a Predictable Output	DP1	Standardize Work
FR11	Identify production rate	DP11	Determine Takt Time
FR12	Determine number of operators	DP12	Manual time/Takt Time
FR13	Determine sequence each worker will work within Takt Time	DP13	Create standardized operation routine worksheet
FR131	Reduce Manual Operation Time	DP1311	Eliminate operations without added value
FR132	Reduce Worker's Movement	DP1312	Eliminate wasted movement
FR133	Reduce Machining Cycle Time	DP1313	Eliminate "non value added machining time"
FR1321	Reduce Walking Time	DP13121	Move machines/stations closer
FR1322	Reduce Material Handling Time	DP13122	Place material at point of use
FR2	Create Continuous Flow	DP2	Connect processes with same volume requirements
FR21	"Jidoka" Separate Machine's Work from Operator's Work	DP21	Multi-functional worker
FR22	Manpower Flexibility	DP22	"U" shaped layout
FR23	Reduce Inventory between Operations/Machine	DP23	Units from one operation to the next one 1 by 1
FR3	Produce what it is needed and when it is needed	DP3	Pull System
FR31	Control Start Time of Machine/Cell	DP31	Kanban Delivery
FR32	Make Consistent Quantity	DP32	Kanban Quantity
FR311	Authorize Production of a standard container	DP311	Production Ordering Card
FR312	Authorize preceding cell to replenish demanding cell	DP312	Withdrawal Card (Internal Move Card)
FR313	Authorize supplier's cell to replenish customer plant's cell	DP313	Withdrawal Card (Supplier Move Card)

48	Write down in notebook part # and valve #	95						
49	Engrave part # & valve #		38	29	32	32	29	30

Total of non value added time	1970 sec. or 33 min						
Total time in sec. for each valve		582	482	1191	429	408	606
Total Non-Value added time/Total Value added time	65 %						

Table 3: Process Analysis on the assembly of six level valves

The steps and operator's motions are shown in Figure 9.

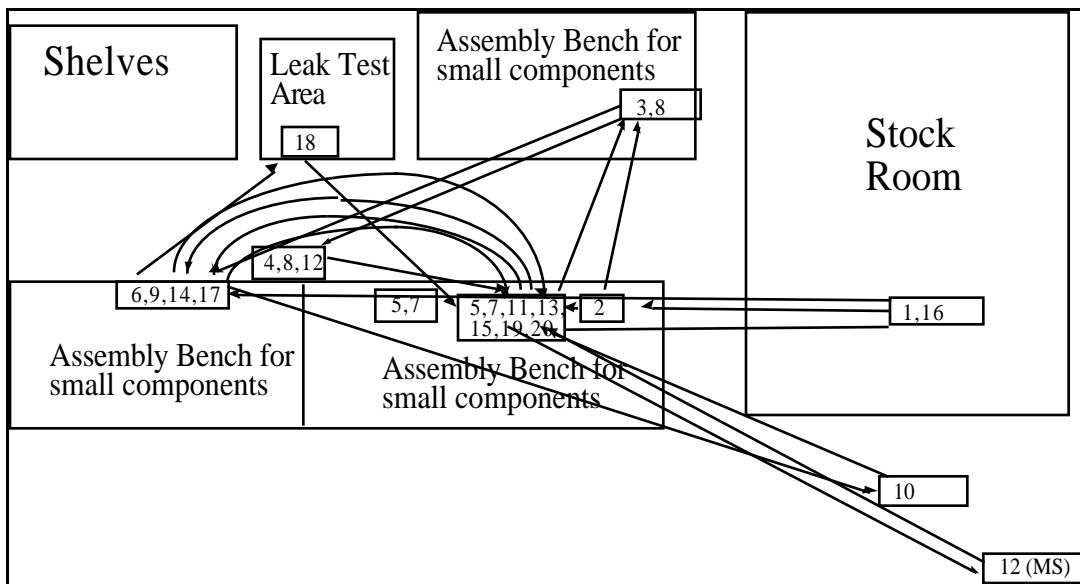

Figure 9: Traditional Flow for assembling level valves at VRA

The same study was done with the regulators, level arms and delco valve assemblies.

Original Configuration of Company XYZ

In the original cell design, the fixturing was designed so that the machine cycle time was balanced by increasing or decreasing the number of parts made at the same time by each machine. In other words, the objective function in this company was to design the Cycle Time as a function of the part numbers in each machine.

$$CT_i = F(P_i) \tag{5}$$

where P_i is the number of parts in the machines. They thought was that by maximizing machine utilization the performance of the manufacturing system would increase. To maximize machine utilization, the operator were made to follow a series of "13 non-sequential" steps in order to produce 8 parts as a result of the 13 steps. The best way to describe this design is by representing the 13 steps in the next figure (Figure 10)

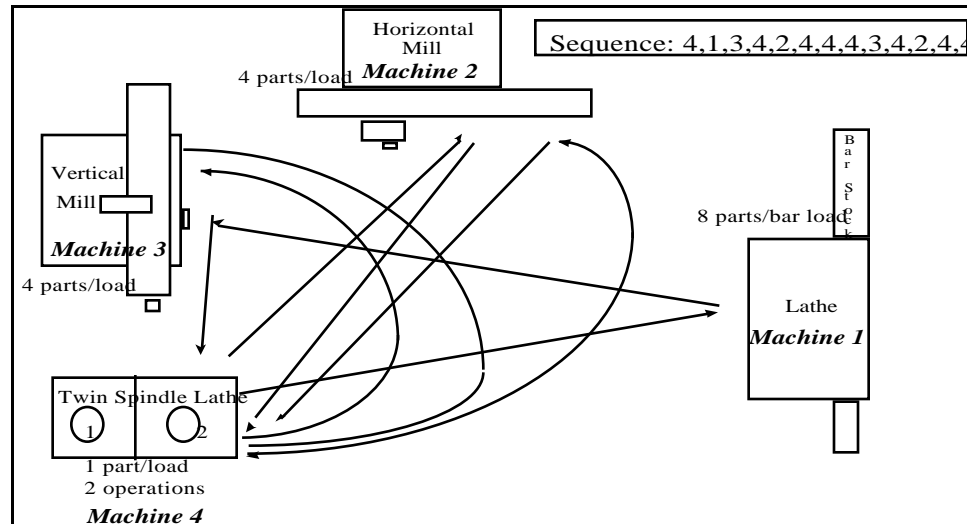

Figure 10: (13) Non-sequential steps to produce 8 parts

The original design did not meet the required production of 400 parts/day. This new design was planned to produced 384 parts/day; however they were only able to produce 310 parts/day.

Basically what was done at this company was 1) to find “the constraint”, which in this case they selected to be the “bottleneck machine”, then 2) schedule the production around the constraint or bottleneck machine[7].

This company accepted the improvements suggested by this design, but did not realize that the production problem was not solved. What was done at this company by developing a design to optimize the bottleneck resulted in hiding the problems (in terms of machine and operator’s motion) by increasing the batch size. The ultimate

improvement that was recommended to achieve the target production was to buy new equipment.

Results from Company VRA and Company XYZ

By following the steps or methodology described previously and developed with the help of axiomatic design, the authors were able to perform improvements in two companies. Not too many details will be given in order to illustrate the main points of axiomatic design application to manufacturing systems design. The first company to be discussed will be VRA, in which the assembly area was completely redesigned. The second company, Company XYZ, will be discussed afterwards.

Company VRA

Some of the results created by redesigning the assembly area are the following:

1. Elimination of the Stock Room
2. Cycle Time of parts in assembly decrease by more than 50 %
3. Work In Process inventories reduced by more than 60 %
4. Space Reduction by more than 40%
5. Better quality of final product

An example of the new valve assembly process is show in Figure 11. This can be compared with the traditional or original flow, which is represented in Figure 9.

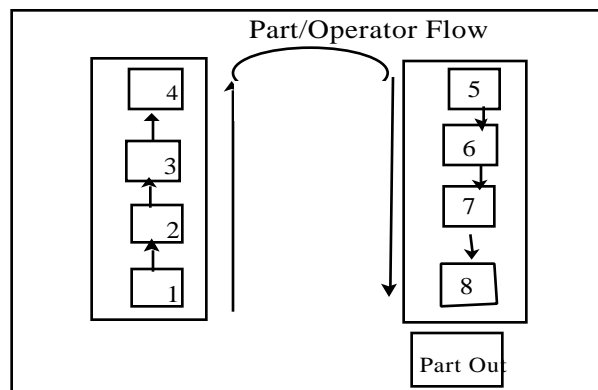

Figure 11: Level Valve Continuous Flow

The production controller system, like the one shown in Figure 6 has been implemented, but it will not work perfectly until the machining area is converted to a better system by following the same design sequence developed for the assembly area. The next step in this company will be to convert the machining area to a cellular manufacturing environment.

Company XYZ

The second company that was studied, was basically analyzed with the same concept as before. The primary result is that the problems for not meeting demand were identified and solved. A production rate of 400 parts per day was achieved; therefore the customer demand will be met.

The first step taken in the improvement of the current process, was to analyze the current production and become familiar with the product. After this, the guidelines developed with the use of axiomatic design were applied.

In this cell the operator knew how to use every machine, and the machines were arranged in a "U" shaped layout. Initially, these two aspects were basically the only two steps done from the guidelines developed in previous sections. In order to improve the process, the authors followed the methodology developed with the help of axiomatic design. By decomposing to the lowest possible level, the root cause of the problem was found and the operations were improved. The production rate of 400 parts per day was achieved. No major redesign of machines was done and even a manual horizontal machine could replace a CNC horizontal machine (Machine 2 in Figure 10). The CNC machine can be moved to another cell that really needs the capabilities and flexibility of the existing

CNC machine. Single piece flow was implemented causing a drastic reduction in work-in-process inventory (more than 80%).

Since one piece flow was implemented and machines were improved, the operator will follow the sequence of the machines (1,2,3,4 and back to 1). The machines are setup in order to follow the process of the part. The new operator sequence is shown in the next figure (Figure 12):

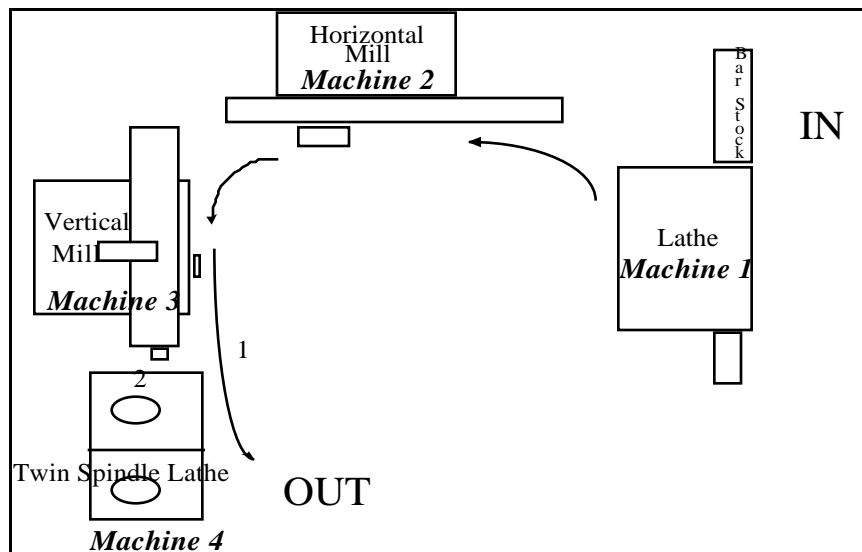

Figure 9: Sequence Operator will follow to produce parts

In order to accomplish FR1313, which is reduction of machining cycle time, an extensive analysis of the machines needs to be performed. When studying the bottleneck machine (Machine 3), it could be seen that there was coupling between the fixture that holds the part and the tool changing motion. The reason it is taking so long for this machine to change a tool is that the working bed has to move to the starting position (outside the working area) when the machine changes a tool. By looking at the dotted lines in Figure 13, it can be seen that if the working bed does not move out of the working area, the tool will contact the fixture and the parts on the fixture, causing the tool, the part, and the fixture to be damaged.

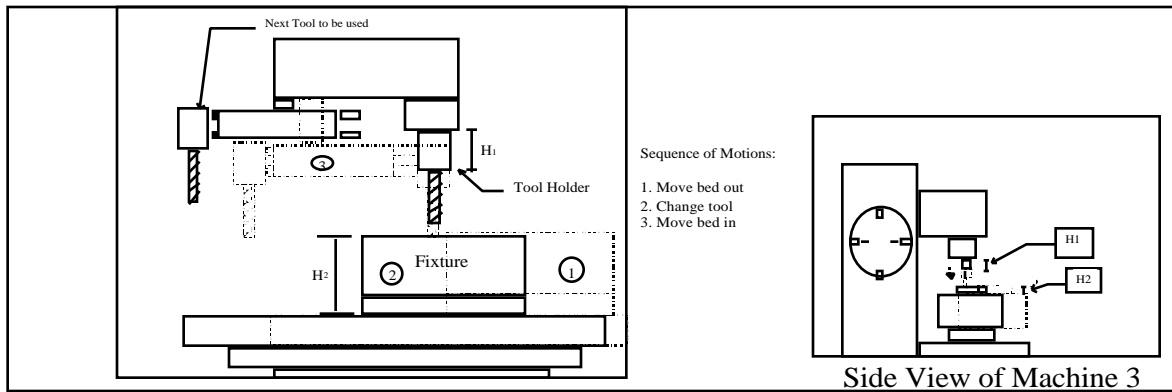

Figure 13: Tool Change Motion of Machine 3

By redesigning the fixture, the cycle time on this machine was reduced by more than 30 seconds. Other cost-effective design improvements were made in order to meet the customer demand.

Conclusions

This paper provides a design methodology for lean production which connects manufacturing system design objectives to operation design parameters. It also focuses the design of operations by eliminating non value added time or waste.

By analyzing the requirements of internal and external customers within a company, a manufacturing system design methodology is proposed. In this paper, the methodology was used to design an assembly area and to improve a machining cell at two different companies. The design of new and existing manufacturing processes is analyzed by design axioms and improved by decoupling processes. These guidelines not only are used to improve an existing process or design a new process, but also will show why, when and how, several practices described for “lean” manufacturing systems need to be applied.

For future work, the authors will redefine and extend the current approach, so that a comprehensive design structure that treats all design elements results. This type of methodology will be extended to treat, in general, other large systems [8]

References

- 1 Suh, Nam P., *The Principles of Design*, Oxford Press, New York, 1990.
- 2 Cochran, David S., *The Design and Control of Manufacturing Systems*, Auburn University, Alabama, 1994.
- 3 Gilbreth, Frank Bunker, *Fatigue study, the elimination of humanity's greatest unnecessary waste; a first step in motion study*, Sturgis & Walton Company, New York, 1916.
- 4 Japan Management Association, *Kanban and Just-in-Time at Toyota*, Productivity Press, Massachusetts, 1989.
- 5 Shingo, Shigeo, *A Revolution in Manufacturing: The SMED System*, Productivity Press, Massachusetts, 1985.
- 6 Ohno, Taichi, *Toyota Production System, beyond large-scale production*, Productivity Press, Massachusetts, 1988.
- 7 Goldratt, Eliyahu, *An introduction to theory of constraints: the production approach*, Avraham Y. Goldratt Institute, New York, 1992.
- 8 Suh, Nam P., *Journal of Manufacturing Systems, Trends and Perspectives: Design and Operation of Large Systems*, Vol. 14 #3, 1995.