

THINKING AND PRACTICE IN PRIMARY SCIENCE CLASSROOMS:
A CASE STUDY

Robin Graham Smith
2

Submitted in accordance with the requirements
for the degree of PhD

The University of Leeds, School of Education

December 1988

ABSTRACT

This thesis presents a case study of the thinking and practice of an experienced primary teacher as he planned and taught a term's science topic on toys with his class of 9-10 year olds. The teacher planned the topic as a series of activities intended to promote investigation and problem-solving by his pupils. Most of the time pupils worked in small groups, testing and making vehicles or models. Information about the teacher's theories and his plans for teaching the topic was collected through interviews, conversations and written notes over the school year. In the third term, when the topic was taught, his actions and thoughts in the lessons were traced through classroom observation and audiorecording.

Analysis of the teacher's theories identified his beliefs and his repertoire of knowledge on which he drew in planning; his specific subject knowledge in science was related to his general theories of teaching and learning. His planning was seen to be a layered process in which he formed images of the flow of activity in each layer: the year, term, activity and lesson. The teacher's thinking during lessons, referred to as thinking-in-action, was closely related to the classroom action but involved more than thoughts about immediate interactions and decisions. The analysis of dilemmas identified by the teacher provided insights into the nature of his thinking-in-action and its influence on his theories.

The relationship of thinking and practice in this case of teaching was compared to Schon's (1983,1987) account of the reflective practice of professionals, particularly to his concept of reflection-in-action. A model was developed within which a teacher's theories, planning and thinking-in-action can be related to one another and to action in a particular situation. Implications for research into teachers' thinking, for primary science and technology, and for the professional development of teachers are discussed.

CONTENTS

LIST OF TABLES
LIST OF FIGURES
ACKNOWLEDGEMENTS

		<u>Page No</u>
CHAPTER 1	INTRODUCTION; THE ORIGINS, CONTEXT AND FOCUS OF THE STUDY	
1.1	<u>Origins of This Study</u>	1
1.2	<u>The Primary Science Context and Teachers' Thinking</u>	3
1.3	<u>Focussing the Problem and Selecting the Site</u>	7
1.4	<u>Working with a Teacher</u>	11
1.5	<u>Structure of the Thesis</u>	13
CHAPTER 2	METHODOLOGY; CASE STUDY, QUALITATIVE RESEARCH, METHODS USED IN STUDYING TEACHERS' THINKING, METHODOLOGICAL DECISIONS IN THIS STUDY	
2.1	<u>Introduction</u>	18
2.2	<u>Case Study</u>	18
2.3	<u>Case Study Related to Fieldwork, Ethnography and Qualitative Research</u>	25
2.4	<u>Choosing Methods in Case Study, Fieldwork and Ethnography</u>	28
2.5	<u>Methods Used in Research on Teachers' Thinking</u>	33
2.6	<u>Methods Used in This Study</u>	36
2.7	<u>Methodological Decisions Through the Study</u>	53
2.8	<u>Questions of Validity: Checks on Data and Analysis</u>	57
CHAPTER 3	REVIEW OF LITERATURE ON PRIMARY SCIENCE AND TEACHERS' THINKING	
3.1	<u>Introduction: the Scope and Sequence of this Review</u>	61
3.2	<u>Primary Science: the Background and Contemporary Developments</u>	62
3.3	<u>The Growth of Design, Technology and Problem-Solving</u>	66
3.4	<u>Views on the Nature of Science and its Learning</u>	67
3.5	<u>Analysis of Processes in Primary Science</u>	72
3.6	<u>Analysis of Concepts in Primary Science</u>	76
3.7	<u>Theories of Learning in Primary Science</u>	78
3.8	<u>Views on the Learning and Teaching of Concepts</u>	80
3.9	<u>Views on the Learning and Teaching of Processes</u>	84
3.10	<u>Organisation of the Review of Literature on Teachers' Thinking</u>	90
3.11	<u>Why Study Teachers' Thinking?</u>	90
3.12	<u>Conceptualising the Field</u>	92
3.13	<u>A Descriptive Framework for Defining the Field</u>	97

3.14	<u>Influences of the Immediate Setting and the Broader Context on Teachers' Thinking</u>	99
3.15	<u>Teachers' Theories</u>	102
3.16	<u>Teachers' Planning</u>	108
3.17	<u>Interactive Thinking, Teachers' Thinking and Decisions During Lessons</u>	112
3.18	<u>Toward an Integrated Account of Thinking and Practice</u>	115
3.19	<u>Summary of Implications of the Literature Review</u>	116
CHAPTER 4	THE WORKING MODEL USED AS A FRAMEWORK FOR THE CASE STUDY	
4.1	<u>Introduction: Origins of the Model</u>	119
4.2	<u>Generation of the Framework in this Case</u>	121
4.3	<u>Use and Modification of the Framework during Fieldwork</u>	123
4.4	<u>Development of the Working Model During Analysis</u>	124
4.5	<u>The Situation</u>	128
4.6	<u>The Teacher's Theories</u>	129
4.7	<u>Planning Thoughts</u>	130
4.8	<u>Thinking-in-Action</u>	132
CHAPTER 5	A DESCRIPTIVE AND CHRONOLOGICAL OVERVIEW OF THE CASE	
5.1	<u>Introduction</u>	134
5.2	<u>Downhill</u>	138
5.3	<u>Uphill Struggles</u>	140
5.4	<u>Mangonels</u>	141
5.5	<u>Choices</u>	142
CHAPTER 6	SITUATION: THE SCHOOL SETTING AND THE PEOPLE IN THE STUDY; INFLUENCES ON THE TEACHER'S THINKING	
6.1	<u>Introduction</u>	144
6.2	<u>The School</u>	145
6.3	<u>The Children</u>	151
6.4	<u>The Teacher</u>	157
6.5	<u>The Researcher</u>	164
6.6	<u>Relationships Between the Situation and the Teacher's Thinking</u>	166
CHAPTER 7	THE TEACHER'S THEORIES	
7.1	<u>Introduction and Overview</u>	174
7.2	<u>The Data and Analysis of George's Theories</u>	175
7.3	<u>George's Theories of Science Teaching and Primary Science</u>	177
7.4	<u>George's Theories of Primary Science and Children's Learning</u>	186
7.5	<u>George's Theories of Teaching</u>	191
7.6	<u>A Repertoire of Knowledge</u>	193
7.7	<u>Discussion of the Teacher's Theories</u>	194
7.8	<u>Relationships Between Theories and Other Aspects of Thinking</u>	199

CHAPTER 8	THE TEACHER'S PLANNING	
8.1	<u>Introduction and Overview</u>	204
8.2	<u>The Data</u>	206
8.3	<u>The Frame and Aims for the Year</u>	208
8.4	<u>George's Image of the Summer Term</u>	210
8.5	<u>Planning the Content. Selection and Sequencing</u>	212
8.6	<u>Discussion of the Process and Structure of George's Planning</u>	216
8.7	<u>Planning a Lesson</u>	221
8.8	<u>Putting the Plan into Practice: the first Lesson of the Topic</u>	224
CHAPTER 9	DOWNHILL	
9.1	<u>Introduction and Overview</u>	227
9.2	<u>George's Plans for 1 May</u>	229
9.3	<u>George's Setting of the Task on 1 May</u>	231
9.4	<u>The Action on 1 May</u>	233
9.5	<u>George's Evaluations of the Lesson and Follow Up Work</u>	237
9.6	<u>George's Plans for 4 May and After</u>	244
9.7	<u>George's Setting of the Task on 4 May</u>	247
9.8	<u>The Action on 4 May</u>	250
9.9	<u>The Action on 8 May</u>	251
9.10	<u>The Action on 11 May</u>	252
9.11	<u>Discussion of the Analysis of George's Thinking and Primary Science Issues</u>	255
CHAPTER 10	UPHILL STRUGGLES	
10.1	<u>Introduction and overview</u>	260
10.2	<u>George's Planning</u>	264
10.3	<u>Setting the Task and Into Action with Bobbin Tanks on 14 May</u>	271
10.4	<u>Continuing the Bobbin Tank Investigations - 18 May</u>	276
10.5	<u>Onto the Design Task - 24 and 25 May</u>	281
10.6	<u>Difficulties and Dilemmas - Reflections on 27 May</u>	286
10.7	<u>Difficulties and Decisions - Action and Thought on 7 June</u>	288
10.8	<u>Discussion of the Analysis of George's Thinking and Primary Science Issues</u>	292
CHAPTER 11	MAKING MANGONELS	
11.1	<u>Introduction and Overview</u>	300
11.2	<u>George's Planning</u>	303
11.3	<u>Setting the Task and Into Action on 12 June</u>	306
11.4	<u>Ideas and Investigation - Planning for 15 June</u>	308
11.5	<u>Ideas and Investigations - the Lesson on 15 June</u>	
11.6	<u>The Siege - the Lesson of 21 June</u>	317
11.7	<u>Making Remote Controls - a Problem-Solving Brief for 2 July</u>	323
11.8	<u>Discussion of the Analysis of George's Thinking and Primary Science Issues</u>	327

CHAPTER 12	CHOICES	
12.1	<u>Introduction and Overview</u>	335
12.2	<u>George's Planning</u>	337
12.3	<u>Choices - Setting the Task on 10 July</u>	338
12.4	<u>The Lesson on 10 July - The Action</u>	338
12.5	<u>13 July - My Last Visit</u>	342
12.6	<u>Discussion and Evaluations</u>	343
CHAPTER 13	ON REFLECTION. MODELS REVISITED	
13.1	<u>Introduction</u>	350
13.2	<u>The Situation</u>	353
13.3	<u>A Teacher's Theories</u>	354
13.4	<u>Planning</u>	360
13.5	<u>Thinking-in-Action</u>	366
13.6	<u>Summary of Relationships and Concepts in an Integrated Model of Teachers' Thinking</u>	372
CHAPTER 14	IMPLICATIONS OF THE STUDY: TEACHERS' THINKING, PRIMARY SCIENCE, PROFESSIONAL DEVELOPMENT AND THE CHALLENGE OF CURRICULUM CHANGE	
14.1	<u>Research in Teachers' Thinking: Methodological Issues Concerning the Style and Use of Research with Teachers</u>	380
14.2	<u>Research in Teachers' Thinking: Substantive Issues Concerning the Context, Content and Structure of Teachers' Thinking</u>	387
14.3	<u>Primary Science: Promoting Investigation and Problem-Solving</u>	397
14.4	<u>Primary Science: Learning and Teaching Scientific Ideas</u>	404
14.5	<u>Teachers' Professional Development and In-Service Education</u>	413
BIBLIOGRAPHY		422
APPENDICES:		
APPENDIX 1	CODING SYSTEM USED FOR LISTING AND REFERRING TO DATA	437
APPENDIX 2A	LIST OF DATA HELD	438
APPENDIX 2B	SAMPLE OF DATA RELATING TO ONE LESSON	441
APPENDIX 3A	SUMMARY OF INTERVIEWS AND CONVERSATIONS	469
APPENDIX 3B	NOTES ON EACH INTERVIEW AND CONVERSATION	470
APPENDIX 3C	TRANSCRIPTS OF TWO INTERVIEWS	478
APPENDIX 4	DATA USED IN ANALYSIS OF EACH CHAPTER OF THE STUDY	495
APPENDIX 5	METHODOLOGICAL ISSUES AND DECISIONS OVER THE YEAR	498
APPENDIX 6	PROCEDURES USED IN ANALYSIS OF INTERVIEWS	502
APPENDIX 7	ANALYTICAL CATEGORIES AND COMMENTS FOR CODING DATA	504
APPENDIX 8	PROCEDURES FOR TRIANGULATING ANALYSIS OF INTERVIEWS WITH OTHER DATA	508
APPENDIX 9	NOTE ON THE ETHICAL FRAMEWORK	509
APPENDIX 10	CONVENTIONS USED IN TRANSCRIPTION	511

LIST OF TABLES

		<u>Page No</u>
TABLE 1.1	SUMMARY OF THE TEACHER'S AIMS AND STRATEGIES	11
TABLE 1.2	CHRONOLOGY OF THE RESEARCH OVER 1983-84	13
TABLE 2.1	APPROACHES USED IN RESEARCH ON TEACHER'S THINKING	32
TABLE 2.2	OUTLINE OF SIX MAIN INTERVIEWS	48
TABLE 2.3	STAGES IN THE ANALYSIS	58
TABLE 5.1	PREPARATIONS FOR THE SUMMER TERM SCIENCE ACTION AND RESEARCH	135
TABLE 5.2	ACTIVITIES OVER THE SUMMER TERM	137
TABLE 8.1	GEORGE'S AIMS AND STRATEGIES FOR THE SUMMER TERM'S SCIENCE TOPIC	207
TABLE 9.1	OUTLINE OF THE ACTION AND DATA IN 'DOWNHILL'	228
TABLE 9.2	GEORGE'S ASSESSMENT SCHEME FOR PUPILS' WORK OF 1 MAY	239
TABLE 10.1	OUTLINE OF THE ACTION AND DATA IN 'UPHILL STRUGGLES'	263
TABLE 11.1	OUTLINE OF THE ACTION AND DATA IN 'MAKING MANGONELS'	302
TABLE 12.1	OUTLINE OF THE ACTION AND DATA IN 'CHOICES'	336
TABLE 14.1	DILEMMAS OF THINKING AND PRACTICE IDENTIFIED IN THIS STUDY	396

LIST OF FIGURES

		<u>Page No</u>
<u>Figure 2.1</u>	<u>Classroom plan showing common starting point for observations and initial movement of teacher</u>	41
<u>Figure 2.2</u>	<u>Flow of analytical activities</u>	55
<u>Figure 3.1</u>	<u>Features of a model of learning for primary science (Osborne and Harlen, 1983)</u>	89
<u>Figure 3.2</u>	<u>Framework for reviewing the field of teachers' thinking</u>	98
<u>Figure 4.1</u>	<u>Starting point for the working model</u>	120
<u>Figure 4.2</u>	<u>Representation of the initial framework in the study</u>	122
<u>Figure 4.3</u>	<u>Working model used in analysis</u>	127
<u>Figure 5.1</u>	<u>The teacher with a group of pupils</u>	135
<u>Figure 5.2</u>	<u>Pupil with his powered model vehicle</u>	135a
<u>Figure 5.3</u>	<u>Pupils testing their mangonels</u>	135a
<u>Figure 6.1</u>	<u>School plan based on drawing by Luke, one of the target pupils</u>	148
<u>Figure 6.2</u>	<u>Classroom layout on a preliminary observation visit</u>	149
<u>Figure 7.1</u>	<u>Extract from document produced by George for use with teachers</u>	179
<u>Figure 7.2</u>	<u>Components of teachers' knowledge base in Wilson, Shulman and Richert (1986)</u>	196
<u>Figure 7.3</u>	<u>Representation of the structure of the teacher's repertoire of knowledge in terms of pedagogical content knowledge</u>	197
<u>Figure 8.1</u>	<u>The nesting of the teacher's planning</u>	217
<u>Figure 8.2</u>	<u>The teacher's plans for the topic related to imagined and real chronology</u>	219
<u>Figure 8.3</u>	<u>George's written plan 10/4/84</u>	222
<u>Figure 9.1</u>	<u>Position of target pupils on 1 May</u>	232
<u>Figure 9.2</u>	<u>Pupil's work</u>	240
<u>Figure 9.3</u>	<u>Pupil's work</u>	241
<u>Figure 9.4</u>	<u>Pupil's work</u>	242

<u>Figure 9.5</u>	<u>Basic chassis design used in constructing vehicles</u>	248
<u>Figure 9.6</u>	<u>Board diagram summarising options for final competition</u>	249
<u>Figure 10.1</u>	<u>Luke and Danny's early work with bobbin tanks</u>	261
<u>Figure 10.2</u>	<u>Extracts from TV programme notes</u>	266
<u>Figure 11.1</u>	<u>Dorothy's report on her first Mangonel task</u>	301
<u>Figure 11.2</u>	<u>Published source of mangonel ideas</u>	305
<u>Figure 11.3</u>	<u>Rebecca's jotter on 15 June</u>	310
<u>Figure 11.4</u>	<u>Rebecca's report on the results of her mangonel investigation</u>	315
<u>Figure 11.5</u>	<u>William's model</u>	318
<u>Figure 11.6</u>	<u>Susan's written 'report to the General'</u>	321
<u>Figure 11.7</u>	<u>Steven's written 'report to the General'</u>	322
<u>Figure 13.1</u>	<u>Headings and relationships in the original framework used in analysis</u>	352
<u>Figure 13.2</u>	<u>Major elements and relationships identified in this study of thinking</u>	373

ACKNOWLEDGEMENTS

My thanks are due to the following:

Dr Rosalind Driver and Dr Roger Beard for the quality and quantity of their supervision.

Sheffield City Polytechnic and my colleagues for their support.

Claire Bacon and Margaret Lee for their typing and their skill in deciphering my writing.

My family for their patience during my immersion in this case study.

Above all to George Packham and Class 6 for allowing me to share in their work.

CHAPTER 1 INTRODUCTION; THE ORIGINS, CONTEXT AND FOCUS OF THIS STUDY

1.1 Origins of This Study

This study originated in consultancy work with experienced primary teachers who were concerned to improve their science teaching. The underlying approach to professional development in the consultancy was one in which practitioners make explicit their thinking, and reflect upon it with the support and discipline provided by critical friends. A group of primary teachers met twice a term to discuss their ideas and teaching. This informal arrangement had developed from my contacts with teachers and schools as a teacher educator working from the Polytechnic in a northern industrial city. At the time of the study the group had grown to include ten teachers who taught children aged from five to twelve, representing all stages of primary schooling and a variety of school situations. Its activities were formalised in a commitment whereby each member in turn presented evidence of their planning and teaching based on a term's work. I worked with the group, providing support also for individual teacher's collection of evidence in school. We explored the aims and beliefs of the teachers, their plans and decisions, and their classroom interactions. The teachers examined the fit between their ideas and their practice. I acted as a co-ordinator and consultant, and in return gained evidence of thinking by experienced practitioners which suggested

questions and approaches for further systematic study. Teachers' reports on their actions, thoughts and problems are one source for studying the complexity of professional thinking and practice. Previous research such as the work of Lampert (1984) with elementary teachers had illustrated the potential of such starting points for studying the relationship between thinking and action in teaching. Lampert also suggested that analysis of how teachers talked about their own work might lead researchers to understandings and a language which they could share with practitioners. The present study arose in this context, stimulated by the literature and by work with teachers. It was a detailed case study of one teacher from the group, designed to explicate his thinking and practice.

An extended case study was undertaken because it allows exploration of the dynamic relationships between thought and action as they develop in a particular context. It was hoped that this would extend our understanding of how thinking and practice actually occur. The case study was informed by a review of the literature on teachers' thinking and a heuristic model was developed which guided the data collection and analysis.

The account of reflective practice that Schon (1983) developed through work with a number of professions offered a general description which promised a useful perspective. His notion of reflection-in-action and his picture of professional knowledge had been derived from close observation of the actual practice of

experienced professionals. My study of teachers of primary science began with a concern to support thoughtful practice within one area, but it seemed worthwhile to investigate how far it fitted a more general account of professional thinking. I set out to develop accounts of particular teaching situations, testing whether that picture was confirmed or not, without premature reduction of the complexity of thought and action in each case. By studying individual teachers as they taught primary science and thought about it I sought to incorporate the substantive concerns and the context, rather than dealing with the processes of thinking in isolation, as many studies of thinking appeared to do.

1.2 The Primary Science Context and Teachers' Thinking

At the time of this study there were major questions about the practice of primary science and its relation to the aims, policies and plans of teachers or curriculum developers in need of attention, but few rigorous and detailed accounts of these relationships. While the study was being undertaken in 1983-88 there was a rapid growth in primary science in Britain accompanied by a shift to more centralised policy culminating in the National Curriculum (DES 1987, 1988b). Surveys by HMI had highlighted the uneven practice of science teaching in primary classrooms despite several major curriculum projects. Monitoring by the Assessment of Performance Unit included science at age eleven; ten year olds were among the populations surveyed as part

of an international study (Keys, 1987). These surveys and work in other countries are reviewed in Chapter 3 with the literature on primary science. A number of common issues emerging from research, policy documents, and work with teachers were identified as general problems to address in this study. There was a concern over the gulf between what was prescribed as an ideal for primary science and what was found to be the actual practice found in the majority of cases. Surveys and studies by curriculum developers all supported this general concern. A few studies had considered possible solutions to this problem (eg Smith and Sendelbach, 1982). Difficulties were often attributed to the teaching force's lack of appropriate knowledge (eg DES, 1978) but this was not underpinned by any sound or consistent research evidence of what such knowledge should be, and how it was held or used in practice. There were proposals to give those teachers with suitable knowledge or experience important roles in the development of science. There was a growth of curriculum material and support services or resources, but differing views about the way these should be matched to primary practices. More consensus existed over the goals and views of learning, where the emphasis was usually on process and the influence of developmental psychology was still strong. However there were new views and ingredients entering the primary science debate. Scientific concepts and children's ideas were being considered more seriously as the process-content argument was seen as an unhelpful polarisation. Problem-solving and technology were being associated with science as primary schools in many parts of

Britain rapidly adopted developments in craft and design.

At the centre of these changes were those few teachers with interest and with varying degrees of subject knowledge and experience in teaching science, who sometimes had an officially defined responsibility for work in their school or beyond. Teacher educators, advisers and other agencies worked with them in some cases and they were later supplemented by, or joined, another tier of advisory teachers appointed as part of a national strategy to extend primary science. In their own teaching they were working towards a professional knowledge base grounded in practice, but this was often an isolated activity and one where there was little research. Some interesting related work had been done in the Ford Teaching Project, where teachers seeking to develop inquiry/discovery teaching had been supported in action-research. The teaching approaches, research strategies and some of the cases were relevant to the present study (Ford Teaching Project, nd). In Britain there had been few case studies of primary school science other than descriptive accounts and vignettes within curriculum projects (eg Nuffield Junior Science, 1967b). Some more rigorous case studies had been reported from multi-site research during surveys of the state of science in other countries, or as part of curriculum development projects (eg Stake and Easley, 1978; Smith and Sendelbach, 1982; Penick, 1983). There were rather more examples to be found in the research literature on science teaching with older pupils but the prevailing paradigm was quantitative and experimental.

There was evidently a need at this time for research which investigated in depth the thinking and practice of primary science teachers in a manner which could contribute to the knowledge base in this rapidly growing field. A number of important general questions had to be focussed on the situations in which practitioners worked and reflected. The particular settings and broader context needed to be incorporated in investigations which were supportive of professional development for those involved, and which yielded studies of thoughtful practice with wider significance for science education. Beyond this there was a more general area of research which could inform, and be informed by, the particular study of primary science teachers. This was the growing field of teachers' thinking.

Investigations of teachers' thoughts in lessons, their planning and increasingly of their more general theories or beliefs, were accumulating at the time this study was being planned. In America the Institute for Research on Teaching, Michigan State University, was a source of papers (for example, Clark, 1983), and in Europe the first conference was held of the International Study Association on Teacher Thinking. Studies of experienced teachers and of students in training were, in many cases, concerned with elementary school teaching. A range of techniques for collecting and exploring thoughts were being developed (see for example Calderhead, 1981). The potential for relating those

to classroom practice, and of examining the complexity of thinking in more naturalistic ways, was being explored, and a case was made for the reporting of findings in case studies (see for example Clark and Peterson, 1983). I drew upon this research in my work with students who were training to teach in primary schools, and became associated with a study which explored the neglected area of subject knowledge (later reported in Calderhead and Miller, 1985). The investigation of experienced teachers' thoughts over a period in relation to practice in a crucial curriculum area seemed to have potential for illuminating more general models of thinking as well as the particular subject area. There was, however, the danger of extending the original study into one that was too diffuse and too demanding for a single part-time researcher. Care was needed to focus the research questions and define the boundaries of the case.

1.3 Focussing the Problem and Selecting the Site

The group of teachers with whom I worked shared views of what learning in science should be like, although members had considerable autonomy to develop their own ideas in their varied school setting. The teachers were interested to explore how far their intentions were realised in their teaching, and a number of limited studies were supported which generated material for use by the group and other teachers. However more detailed and rigorous research was required to answer questions about how and why teachers thought and acted as they did. The internal links

among different aspects of thinking, and the external links with actions, needed to be traced over time. A portrayal which illuminated the general processes of thinking was necessary, but not sufficient. Substantive concerns in primary science had been identified which needed to be addressed: the use of the subject and professional knowledge; the emphasis on process learning, and emerging interest in concepts; the development of technology and problem-solving. The study needed to address these concerns, but in the context of the normal practice of classroom teaching.

In order to examine the complexities of the issues involved in detail it was decided to work with one teacher in depth on a case study of his thinking and teaching in relation to a term's science project. The negotiation of this began a year before the term in question, and involved progressive focussing of the study as he defined his plans for that term. Table 1.1 summarises the expressed aims and strategies which the teacher intended should underpin his work for that term. These served as a framework for the initial collection of data, within a working model of teachers' thinking, developed as described in Chapter 4.

The teacher taught the whole primary curriculum to his ten year olds in a junior school where he also had a post of responsibility for science and mathematics. Much of his science teaching occurred within cross-curricular topics, which were often related to the local environment. This was a characteristic of the work in the school and the local education

authority, as was the emphasis on pupils' activity and experience as a basis for their learning. His science teaching in the summer term 1984 which was the focus of my study was based on a topic concerning 'Toys and Models'. He intended to use this chiefly as a vehicle for teaching skills and attitudes which would help pupils plan and pursue investigations independently, but also as an opportunity for extending their ideas about forces and structures.

I interviewed the teacher at intervals over the year 1983-84 to explore his thinking, and kept records of all our unplanned conversations and his notes. I observed and recorded the science lessons over the summer term, collecting copies of pupils' work and interviewing a sample of pupils who were the target for my observations of the teacher's interactions.

The lessons of the science topic were grouped in units, each based on an activity or related activities that the teacher had anticipated in his initial plans. However the selection and sequence of those activities was not determined at the start of the term. The teacher's selection and use of the activities was influenced by his evaluation of the progress of the topic, his general theories and more specific constraints and opportunities in this particular situation. The study examined how the images he formed of the term's topic, the activities and the individual lessons related to the classroom action.

The case study reports the action and thinking in chapters which reflect the units of activities over the term:

Downhill; in which pupils tested toy cars and made simple model vehicles.

Uphill struggles; in which pupils made and tested powered models.

Mangonels; which were model siege catapults built, tested, and elaborated by pupils.

Choices; in which pupils had a choice of activities; including investigations with bicycles.

The uneven progress toward this freer choice and pupils' increasing ability to pursue independent investigations is traced. The teacher's own thinking is reported in relation to that action. The analysis of his thinking identifies the concepts of a repertoire of professional knowledge and of dilemmas of practice; it examines the extent to which Schon's (1983) general picture of the reflective practice of professionals is consistent with the present case.

TABLE 1.1 SUMMARY OF THE TEACHER'S AIMS AND STRATEGIES

A. Processes and Roles

From the start of the year the teacher was concerned to foster more independence and inquiry. Within this general intention he itemised

1. pupils' readiness to pursue their own ideas, and
2. to think for themselves, and
3. to plan and organise their own investigations.

The strategies he identified as appropriate for this were

1. to avoid forcing his ideas on pupils
 2. to allow time for development of their own ideas
 3. to change the form of recording and reduce the emphasis on written records.
-

B. Concepts and Content

As a vehicle for this learning he had in mind at first a topic on cars, transport or forces for the summer term. This developed into plans for a topic on toys and cars in which he saw opportunities for lots of work on forces, particularly friction, and structures.

The content and activities were seen as providing opportunities for incidental learning and some direct teaching of scientific ideas, skills and application of learning in making and testing models, and above all the processes identified in A.

1.4 Working with a Teacher

In this style of research it is sometimes difficult to identify the point at which the study can be said to have begun, and the initial negotiations are part of the developing design. They are also crucial in establishing relationships and protocols. In this case they grew out of the general procedures agreed with the group of teachers, but required particular attention to issues such as negotiation of entry, field roles and controlling release of data. Roles and procedures during data collection are

discussed in Chapter 2. Clearance of written records by those involved and an assurance of anonymity were features of the ethical framework governing work with the group of teachers. Once cleared, the data would be lodged in my case record for use. Any other uses of raw data, eg for quotation or teaching purposes, would be agreed with the teacher. He and his colleagues showed little concern or awareness of the need to formalise such procedures, but it was seen as part of the responsibility of a researcher to make explicit agreements over details for particular circumstances. Access and support from the head and Local Education Authority advisers was given readily, perhaps reflecting the trust placed in the teacher as well as the response to my interest in the school and support for the work of all parties. Care was taken to explore at an early stage with the teacher what he stood to gain from involvement and to ensure on the other hand that the data could be collected as required for my study. The study in fact developed into a valued professional experience for both parties, but attention had been given to the creation and formalisation of a framework within which this was possible and problems had been anticipated. The rights of the pupils had also been considered and the pupils' permission was sought for collection of reports or work from them. Exit from the site was planned and visits phased out. At the end of the term's observations feedback and thanks were given to pupils and teacher and the head was formally thanked and invited to comment on the study. The chronology of the research in 1983-84 is summarised in Table 1.2. Detail of these and the

ensuing steps in analysis leading to the account in this thesis are given in Chapter 2. The procedures and data are listed in the appendices, which are summarised at the end of this chapter.

TABLE 1.2 CHRONOLOGY OF THE RESEARCH OVER 1983-1984

Summer 1983	Identification of site, negotiations with teachers
Autumn 1983	Meetings with teacher, first interview, first contacts with class made on field trip
Spring 1984	Visits to school, classroom observations and recording trialled, two interviews with teacher - focus and framework of study agreed, plans made for summer term. Small-scale study on another site piloted methods.
Summer 1984	Detailed study on site, three interviews and other conversations with teacher, interviews with pupils, documentary evidence and products, observation of lessons throughout term, audiorecording of teacher, some videotaping. Data checked and indexed. Analysis begun. Exit from site.
Autumn 1984	Clearance of data by teacher. Analysis continued.

1.5 Structure of the Thesis

This introductory chapter has described the origins of the study, the development of the research questions in relation to the fields of primary science and teachers' thinking, the focussing of the research problem on a single site, and the negotiation of a framework for working with a teacher. The organisation of the report which follows is designed to meet the need for a coherent account of the case, the development of an argument derived from analysis of the data, and examination of issues related to the literature. The presentation seeks to provide sufficient detail

of the data and the means whereby it was collected and analysed. Case study reporting requires a balance between such detail and the production of a readable account which is not unwieldy. This issue and questions about appropriate standards in qualitative research are discussed in Chapter 2 which deals with methodological matters. The identification of the case and development of methodologies are so closely related in case study that it was judged appropriate to follow the introduction with the methodological chapter. Following a detailed examination of the case study method, it discusses more general issues in relation to ethnography and qualitative research. Approaches used in the study of teachers' thinking are noted as the choice and use of methods for this case are reviewed. The chapter maintains the argument that methodological decisions should be consistent with the research problem and illustrates how those decisions were made in the course of the case study. The chapter ends by summarising the analytical steps from the data to the final account.

The literature in the two substantive fields of primary science and teachers' thinking is reviewed in Chapter 3. It examines significant issues in science education and aspects of teachers' thought which need to be analysed and related. The review identifies and presents a framework within which the study could be organised, and a description of reflective practice to be examined in the light of the case. The argument for presenting an integrated account of thinking in context is advanced.

Chapter 4 explains the development of a working model from the interplay of the literature and the case in the early stages of the study. The research questions and the priorities agreed with the teacher, introduced in Table 1.1, are located within this broader framework for studying a teachers' thinking and practice. This working model structured the collection and analysis of data, and the organisation of the account which follows. It is revisited and reviewed after that account.

Chapter 5 provides a descriptive, chronological overview of the case. It can be read separately and referred to for a summary of the action and research over the school year 1983-84 when the study occurred. The case study opens with Chapter 6 which gives details of the setting and the people involved in the study. It analyses the situation in relation to the aspects of thinking and practice to be investigated, referring to the broader context and influences as well as the immediate setting.

Chapter 7 analyses the teacher's theories and beliefs concerning science, children, learning and teaching. His professional and subject knowledge is related to his view of pupils' learning, and analysed with reference to planning and practice. Chapter 8 traces his planning up to the start of the summer term. It develops a picture of the planning process as layered or nested. The internal structure of the teacher's plans is analysed and related to his theories, the situation and his classroom practice and thinking. Chapters 9 to 12 trace those relationships through

the summer term science topic. Those chapters present a chronological account of the term's work. Issues are identified and documented within each phase of the work. The analysis cumulates from chapter to chapter, exploring the substantive issues in context and deriving a picture of reflective practice in relation to the working model introduced in Chapter 4. Chapter 13 revisits that model, and critically reviews it in the light of the case that has been presented. Models and terms are discussed as the analysis is summarised. Chapter 14 considers the implications of this study with reference to research on teachers' thinking, to primary science, and to in-service education and professional development. Considerable common ground is noted as approaches to building a professional knowledge base for thoughtful practice are discussed under those three headings.

The bibliography list all publications and sources to which reference is made in the text. The appendices include a listing of all data held. The procedures by which this was derived from the case data and used in analysis are outlined at the end of Chapter 2. The content and organisation of the appendices represents a concern to present a suitable selection of material which is manageable yet meets standards of dependability and confirmability. They include summaries of all interviews and related conversations or written communication with the teacher, a range of data sets used in the analysis of one section of the study, and summaries of the data base for each of the Chapters 6

to 12. Any data cited in the text is identified by date and type, either as it is introduced in the account (for instance, "at the start of our interview on 12 April the teacher volunteered his comments on the lesson I had observed the previous day") or by a standardised subscript and form of presentation. The full code and references to data (for example, identifying audiotape and counter number or location on a transcript, page and time for fieldnotes) were only removed at the final stage of writing to produce a more readable account.

CHAPTER 2 METHODOLOGY; CASE STUDY, QUALITATIVE RESEARCH, METHODS USED IN STUDYING TEACHERS' THINKING, METHODOLOGICAL DECISIONS IN THIS STUDY

2.1 Introduction

This chapter examines general methodological issues in relation to the study. It begins by developing the argument for selecting case study as the strategy in the present research. The nature of case study and appropriate standards are considered. Then issues in the broad research tradition which includes case study, ethnography, field work and qualitative methodologies are discussed more generally. After a summary of approaches that have been used in research on teachers' thinking specific methods used in this study are examined, with detailed discussion of observation and interview. Finally the chapter traces the methodological decisions made throughout the study and the checks on data and analysis, with reference to questions of validity as they relate to this style of research.

2.2 Case Study

Case study was selected as the appropriate strategy to investigate the thinking and practice of primary science teachers in the circumstances for the following reasons. The principles of conducting case studies, and their concern with the meanings and perspectives of the actors, were consistent with my stance toward professional development in the related work with

teachers. It was a feasible strategy for the circumstances as I could easily negotiate entry to suitable sites; as a lecturer involved in training primary teachers I had experience of working in classrooms in a number of roles and knowledge of the context and content of the field of primary science. The detailed study of a case using multiple methods can capture the complexity of thought and action. The portrayal of a particular instance provides an opportunity to analyse thinking in relation to practice as it occurs. This can be used to check out the implications of models and may indicate directions for research in the field of teachers' thinking. A teacher's thinking is personal and oriented toward practice in unique situations. Holistic accounts which convey that, and are sufficiently thorough, may be particularly appropriate for reporting on teachers' thinking. In the long term case studies can be a basis for cumulating professional knowledge toward more perceptive interpretation and prudent judgement (Stenhouse, 1985). The field of primary science is not short of prescription, policy, action or ideas; but there is a dearth of detailed, rigorous studies linking thought to practice. Case studies have a contribution to make to the development of a knowledge base in this rapidly growing field.

Definitions of case study tend to emphasise the examination of an instance in action (for example, Macdonald and Walker, 1975), and talk of a bounded instance or bounded system (Kemmis, 1980). The uniqueness of a case and its creation through the study were

stressed by Kemmis, in one of the articles collected under the carefully chosen title of Towards a Science of the Singular (Simons, 1980). The imprecision of definitions has been criticised by Atkinson and Delamont (1986), who point out that boundaries, instances and cases do not exist but have to be constructed. Purely methodological definitions have been eschewed and advocacy of educational case study has origins in opposition to existing research and evaluation paradigms. There is a tendency in general writing on research methods to relegate it to a simpler or preliminary stage of research, or to identify it with the content or techniques of particular studies, or subsume it under ethnography. In defining those features that distinguish case study from other strategies in social science research, Yin (1984) emphasises that it is an empirical study of a contemporary phenomenon in its context using multiple sources of evidence.

Kenny and Groteleuschen (1984) pointed out that arguments for case study have been reactionary where they arise from criticisms of traditional educational research or methodology, but they identified other grounds for its advocacy. In addition to epistemological arguments they noted the appeal of pragmatic arguments and parallels with a historical approach, surprisingly without referring to the work of Stenhouse who cited historical research as he developed the case for case study (Stenhouse, 1978; 1985).

There are a number of questions to consider relating to the conduct, reporting and use of case studies. At the outset there are decisions to make about the ethical stance and the design. Questions about the ethics of research have been much explored by case study workers such as Walker (eg 1983 and 1986). A democratic stance and an agreed ethical framework for matters such as roles, ownership and release of data does not always eliminate difficulties (see eg MacDonald, 1980). In planning and carrying out a study the initial research questions act as foreshadowing problems, but the research design has to respond to the nature of the case. This will involve methodological decisions throughout and a flexibility which can lead to shifts away from the original concerns. Yin (1984, p45) argues that the largest criticism of case studies is based on this type of shift. The conduct of the case and the choice of methods has to be responsive, and the study will be a dynamic activity in which the researcher interacts with the situation; there is a fine line between that and the eclectic use of methods or the idiosyncratic invention of a case study. The effects of the researcher's interventions and bias will also need to be considered.

The evolving, particular and reflexive nature of a case study adds to the difficulties in reporting presented by the extent of the material that may be considered as evidence. Somehow a report must provide an account which can be checked, yet is not too long. It has to be suitable for the audience and purpose: for instance, material for discussion by teacher groups, or

alternatively a thesis, can be produced from a study such as the present one. The structure of a written report has to provide a readable account which is more than descriptive, and provide access to the data and analysis. The reader needs to be able to trace the conduct and analysis of the study as well as believe in the authenticity of the account. The assembly of a data-base, referred to as the case record, from which analysis develops the final account, was explored by Stenhouse (1978) to address the problems of verification and cumulation in case study. However Rudduck (1985) has noted that, although this worked well for the condensed interview-based studies for which it was developed, it may not be the way forward for bigger studies involving long term participant observation.

Questions about the verification and use of case studies have sometimes been framed in terms of a different tradition, for example referring to approaches to validity and generalisation used in experimental and survey research. There is a need for case study research to develop and apply suitable standards. In doing so it can draw upon the more appropriate research tradition of ethnography, field work and qualitative methodology which is discussed in the next section. Researchers working with teachers are also identifying approaches and criteria based on the argument for critical studies of practice to cumulate practical professional knowledge, building on the work of Stenhouse. In the course of an article arguing for action-research and practitioner case study to be combined in a model termed

action-inquiry, Bell (1985) proposed the following summary of criteria of rigour:

Credibility - the study must be believable by those who are competent to judge the subject

Transferability - the study most able to promote the exchange of experience; lessons must be capable of being learned from the evidence provided

Dependability - the study must be trustworthy through having gathered evidence by reliable procedures

Confirmability - the study must be capable of being scrutinized for absence of bias by making its evidence and methods of analysis accessible

(Bell, 1985, p 381)

These seem appropriate criteria to apply in judging the validity of any particular case study and in improving the standards and procedures in case study research which has often been criticised for its lack of established standards or its eclectic, uncritical approach to methodology.

Underlying all these questions at different stages of a case study is the issue of validity. The commonest methodological check used during a study is to collect data using different methods and sources. The comparison of several sets of data or perspectives, often termed triangulation, has been used in educational studies such as the Ford Teaching Project (eg Elliott and Partington, 1975). The use of triangulation is not restricted to case study, and can be widened to a notion of multiple strategies used to overcome bias (Burgess, 1984b). The choice of methods will be guided by the research questions and the purposes of a study (Cohen and Manion, 1985). Different sets or sources of data can be compared in various ways; for instance

interviews may be used to check observations or vice versa with different purposes, as discussed by Stenhouse (1982). In the present study the teacher's statements were compared in an iterative process with field notes and audiotapes of lessons, and statements made at different times were contrasted. The teacher's perspective could be set against that of the pupils where appropriate. The combination of perspectives and methods was guided by the underlying concern to explicate the teacher's thinking and relate it to his practice. Multiple methods can lead to a proliferation of data. In case study this tendency is exaggerated as the researcher strives to be faithful to the case, seeks to avoid premature closure and sees new possibilities as he reflects analytical insights back into the data collection process.

It is now common in case study to have the participants or informed peers review drafts. This is additional to the ethical procedure agreed for release of material, and can range from sharing of vignettes drawn from the study to full reading of a draft report. Face validity in the eyes of the teacher or colleagues was explored during the study by releasing material to the group of teachers and by seeking the comments of the teacher on my records. He had expressed his doubts over the trust that could be placed in many accounts of primary science, which seemed selective and idealised, and was concerned that his practice be portrayed with "warts and all". The comments he and the other teachers provided on the authenticity and detail of records were

therefore seen as valuable checks. A full reading and critical commentary on my analysis, or an audit of data, was not a reasonable demand on busy teachers. Their concerns focussed on criteria of credibility and transferability.

2.3 Case Study Related to Fieldwork, Ethnography and Qualitative Research

In the 1970's and 1980's there was considerable growth of educational research in a tradition encompassing case study, ethnography and field work. This is often associated with qualitative methods, but the contrast with quantitative methods has sometimes confused the issues as they can in practice be complementary. Often the shift to this newer tradition has been in reaction to more positivistic approaches to classroom research, such as observation using prespecified schedules, as signalled in Hamilton and Delamont (1974). Revisiting their paper Delamont and Hamilton (1986) note that in educational research ethnography is booming (sic) but that the long tradition in sociology and anthropology has not always been recognised. There are in fact a number of traditions and styles of research which need to be distinguished.

Burgess (1984b) introduced his guide to field work with two quotations that illustrated a similar style of research in an anthropological study of a distant society by Malinowski (1922) and in an example of a recent educational study by Delamont

(1976). In his earlier anthology (Burgess, 1982) he provided sources from the intervening period, including many who had studied sub-cultures in their own society. Anthropologists have been developing their methodologies and standards since the last century; the related sociological tradition derives from work at the University of Chicago in the 1920's and 1930's. Educational ethnography is a much more recent, and as yet ill-defined, field of investigations which presents an emergent interdisciplinary fusion as Goetz and LeCompte point out in their extended account of its origins (1984). They trace anthropological studies of education and enculturation in distant and local societies, and the influence of psychological and evaluation studies as well as sociology. Educational ethnography draws upon those in defining its focus, methodologies, and outcomes. At this early stage in its development it is not surprising that debate still rages as to its use and abuse and its specific character (see for example Goetz and LeCompte, 1984; Delamont and Hamilton, 1986; Lutz, 1986).

Fieldwork and field research are somewhat ambiguous terms. They refer to methods such as participant observation and unstructured interviews, and to a methodology in which the design of the research develops and is monitored throughout the study (Burgess, 1984b; 1985a). They emphasise the process and development of a field study, and the formation of relationships in the field.

The term ethnography has been loosely used at times to refer to research techniques, particularly participant observation, but it

signifies a specific approach in anthropology. It seeks to uncover the way of life of a group, emphasises the meanings of the members, and produces holistic accounts. Ethnographers strive to remove their preconceptions and to work from the perspectives of the informants toward an interpretation of a cultural scene or group (Goetz and LeCompte, 1984). Fieldwork and ethnography clearly have much in common with case study and their literature was an important methodological source for the present research. For example, the conduct of the study was informed by the literature on the stages in field research and on the role of early data analysis in developing a study (eg Becker and Geer, 1960; McCall and Simmons, 1969; Burgess, 1982). The ethnographic tradition emphasised the importance of thick description based on the perspectives of those involved, and of extended involvement; reflexivity was recognised as more than merely a source of bias (Hammersley, 1983). Proponents of ethnographic research in education have argued that it gets away from the simplistic reduction of prespecified observation schedules (Delamont and Hamilton, 1986) and is particularly suited to bridging the gulf between research and practice (Woods, 1986). However there are distinctions to draw between ethnography and case study and the description of classroom research as ethnographic needs some qualification.

Firstly, many researchers in classrooms are not strangers in an unfamiliar society, unlike anthropologists and social scientists in the ethnographic tradition. Stenhouse (1985) contrasted the

ethnography of outsiders immersing themselves in a strange society with a historical tradition on which case study could draw. His work led to the development of research by practitioners in their own classrooms and to studies by outsiders who are often, as in my case, teachers or educators with cultural knowledge pertinent to the study. Secondly, the focus of educational research need not be on the interpretation of the society and its relationships, although many ethnographies of schooling have been (eg Woods, 1979). Thirdly, case studies which are focussed on a particular issue, or based on intermittent encounters with a group, may use methods which can be described as ethnographic, but are not ethnographies as stressed by Lutz (1986).

2.4 Choosing Methods in Case Study, Fieldwork and Ethnography

Delamont and Hamilton (1986) argued for an open-ended attitude towards research, in which eclectic combinations of research methods can be used, and in which different problems can be tackled by different, mutually appropriate methods. They suggested that instead of looking for one solution to all problems, more consideration be given to the nature of the specific problems being faced and hence to choosing a particular research strategy appropriate for that problem (1986). The methods of ethnography, and of qualitative research in general, cannot be neatly separated from the broader methodological questions. Indeed one of the characteristics of field method is

the intertwining of practical decisions about techniques and methods with theoretical concerns (Burgess, 1985a). The choice of techniques may be eclectic, but should match the research problem and the stance. There is a temptation to adopt techniques that generate a range of data without rigorous review of the possibilities to determine which are most appropriate. In planning a study it is necessary to review, and practice in context, techniques that are feasible as well as productive. In the present case considerable trialling of audiorecording and observational techniques was needed to find the best methods for collecting data on the unpredictable interactions in active science lessons. Technical problems, such as where to locate myself as observer and how to get a transcribable record of the teacher's talk, had to be resolved in ways that were consistent with the context of a fluid primary classroom. The solutions had to serve the overall purpose of investigating the teacher's thinking in relation to his practice. Piloting of methods not only aids these decisions and develops the researcher's skill in using techniques 'in situ', but also suggests how his presence may affect the setting. It is important to monitor this throughout a study. My early contacts with the class were carefully phased so they grew accustomed to me in the role of an interested colleague of their teacher. Then classroom observations and recording were piloted and the impact of my activities was noted. The views of the children and the teacher on this were sought at intervals during the study. It was not surprising to find that the videocamera was the most intrusive

element. Video was in fact being used for a number of reasons which needed clarification. It was incorporated into the design of the research as a stimulus to the teacher's recall of lessons, and to his accounts of his thinking. It also provided a service to the teacher who wanted to gain insights into his classroom practice which were not restricted to my research questions. In the early stages of classroom observation it was an additional record against which to check fieldnotes and audiotapes. However it became clear in the early days of the study that it was not a crucial source of direct evidence and its use could be restricted.

In Chapter 1 it was noted that methodological issues would be reviewed first as they are intimately connected to the development of the study. It is characteristic of qualitative research in natural settings that it can become more focussed as it proceeds, as the investigation identifies what is to be important and how best to collect and handle data. This is a continuation of the sampling or bounding of the case which begins when the problem is identified and sites considered (Miles and Huberman, 1984). On the other hand the early stages of a study may indicate the need to collect other sorts of data or to provide alternative perspectives. With hindsight it is often possible to see a more selective, rigorous approach to the problem and be critical of the naturalistic style as Hammersley (1984) noted in reviewing his own development as a researcher. However looking back at a completed study is not the same as

facing methodological problems at the start, as Walker (1980) points out.

At the time of planning the present study there were a number of collections of articles from the sociological tradition of fieldwork and general accounts of qualitative research methods on which to draw (eg Adams and Preiss, 1960; McCall and Simmons, 1969; Bogdan and Taylor, 1975; Patton, 1980; Burgess, 1982). These offered guidance on issues such as entry and access, ethics, roles and relationships, sampling and ways of collecting and handling data. There was some general advice on approaches to analysis although this was often underrepresented in texts on method. An important source published after the fieldwork was completed offered ideas and urged rigour in analysis (Miles and Huberman, 1984). A literature was accumulating based on accounts of educational studies, including commentaries on their methodology by researchers as well as specific discussion of methods or of issues such as reflexivity (eg Ball, 1983; Burgess, 1984a and 1984b; Hammersley, 1983; Hammersley and Atkinson, 1983). Methods most fully treated in the literature have been, in order of the attention given to them, observation, interview and document analysis. These will be considered in turn as they relate to this study. First it is necessary to note the range of techniques used specifically in studies of teachers' thinking which were reviewed before designing the present one.

TABLE 2.1 APPROACHES USED IN RESEARCH ON TEACHERS' THINKING

experimental quantitative reductionist correlational	underlying <-----> traditions	naturalistic qualitative holistic descriptive
controlled conditions	OBSERVATION structured observation using prespecified schedules	participant observation, 'fieldwork' and ethnography
structured interviews, questionnaires, policy capturing	VERBAL REPORTS semi-structured/ focussed interviews, repertory grid, stimulated recall, think-aloud	unstructured interviews, incidental talk and conversations
records and assessments, surveys, pupils' products	DOCUMENTS ETC plans, evaluations, teaching materials and documents	journals, diaries

2.5 Methods Used in Research on Teachers' Thinking

The range of techniques found in the review of research on teachers' thinking conducted at the start of the study is summarised in Table 2.1.

There had been studies of thinking under controlled conditions, such as classroom laboratories, or simulated planning, sometimes termed policy capturing (Shavelson and Stern, 1981; Clark and Peterson, 1983). Teachers' thoughts during their normal planning had been traced through techniques requiring them to think aloud as they carried out a task such as lesson planning (eg Peterson, Marx, and Clark, 1978). The method may be more intrusive or even disrupt the flow of thinking if used during classroom events to trace decisions, but can be adapted to more naturalistic use when a teacher is able to make comments or keep notes at intervals. There are questions concerning the status and analysis of such verbal self-reports which are not restricted to the study of teachers' thinking, but are particularly relevant where the concern is to tap the thoughts and meanings of an individual teacher. Despite these qualifications it seems any attempt to reconstruct teachers' thinking must draw upon their reports, recognising they are themselves constructed in the research context and subject to a number of influences (as discussed for example in Nisbett and Ross, 1980). Analysis may yield different descriptions if done in different ways and teachers will vary in

their ability to comment on their thinking while teaching. In this case the teacher often made remarks to me as I observed his lessons, reporting on his assessment of progress, or problems he faced, or decisions he was considering. This became one source of evidence, but obviously the sampling was determined by the other pressures on him in the lesson.

Various ways of prompting a teacher's thoughts had been used by researchers, usually to assist recall of thinking which could not be reported during busy lessons: audiorecords; feedback from field notes; still photographs; verbal comment from an observer or pupil; reference to plans and intentions or to particular incidents; or simply the existence of an audience or the requirement to produce some report. Video recordings were increasingly being used as a stimulus. Stimulated recall was the method used in most of the studies of thinking during lessons reviewed by Shavelson and Stern (1981, table 3), and Clark and Peterson (1983, table 4). They varied in the extent to which the researcher or the teacher had control of the stimulus, and the extent to which there was free response or predetermined questioning (cf McKay and Marland, 1975; Marland, 1978; Peterson, Marx and Clark, 1978; McNair, 1978-9). Such variations are likely to yield different emphases in accounts produced by teachers, who may themselves feel that their reports do not really capture what was in their minds at the time (as noted in Calderhead, 1986). The limits and possibilities of stimulated recall had been discussed by Calderhead (1981). In combination

with other sources of data, and collected over time, techniques for stimulating recall have considerable potential for investigating thinking in context. They can be a starting point for more extended interviewing.

Approaches to interviewing in studies of teachers' thinking extended from highly structured questioning, through less structured probing of teachers' thoughts and plans, to more conversational styles emphasising the informants' control over the process (eg Elbaz, 1983). Other methods such as repertory grid had been employed to elicit teachers' theories and beliefs, as advocated by Munby (1982), and elaborated by Pope and Keen (1981). Observation in the classroom, or in the staffroom and wider school context, had increasingly been used to contextualise and trace teachers' thinking in relation to action. Mackay and Marland (1978) and Morine-Dershimer (1984) argued that this combination of methods gave a more coherent and insightful account. A few detailed ethnographic studies had focussed on a teacher's thinking (eg Janesick, 1977). There was a growth of interest in collecting biographical evidence to inform the picture of a teacher's thinking derived from interview and classroom study, as advocated by Goodson (1983). Documentary evidence had been used, including journals kept by teachers, and collection of their written plans, assessments or records.

2.6 Methods Used in This Study

The position reached by reviewing the methods used in research into teachers' thinking was that multiple strategies were essential to the design of the present study. Appropriate selection and combination was needed in order to check accounts and perspectives, to trace changes over time, to relate aspects of thinking and action, and to produce a holistic account that was authentic. A rich observational data base was necessary to relate practice to thinking. The teacher's interactions with pupils and his thoughts before, during and after lessons had to be recorded. Evidence was needed of his plans, evaluations, his more general theories and his knowledge base. This data had to be collected in ways that were appropriate to the teaching situation. The methods selected were observation and audiorecording in lessons, supplemented by some videorecording as noted above; recording of volunteered comments during lessons, discussions before and after lessons, extended interviews phased over the year, and unplanned conversations; collection of any written documents used or produced by the teacher, and pupils' work; some use was made of videorecords and other data to stimulate recall and reflection.

2.6.1 Classroom Observation

Observers in classrooms can take a variety of roles, ranging from full participation to the detached stance of a fly on the wall (or the man in the Wendy house as in King, 1984). Each has its problems and advantages, and the position taken needs to be

explicit, appropriate to the situation and the purpose of the study, and theoretically consistent. Participant observers enter into the life of the group and gain experience and insights which may be denied those who seek to reduce their impact on the setting and to avoid being influenced by their involvement. If the researcher is concerned to describe the life of a group through the perceptions of the members then participation is more appropriate, but should the goal be to report on features from the view of an outsider then detached observation is in order. In practice other matters also have to be considered. Access, acceptance, the response of people in the study, the researcher's own background and skills, and the ethical framework within which a study is conducted will all affect the roles that should and can be taken. Different roles may also suit different parts of a study, as discussed by Burgess (1984b). None of these decisions can be left to chance and should be agreed and recorded, even though teachers may be reluctant to formalise arrangements (Rudduck, 1982).

In this case a general agreement for the range of roles I would adopt in working with the group of teachers had been agreed and details were negotiated for any work on individual sites. The framework for the collection and analysis of data was developed in the two terms leading up to the term of fieldwork, as described in Chapter 4. At the same time the discussions with the teacher established the procedures and stance for my classroom activities. The basis of the ethical framework is

summarised in Appendix 9. My position as a teacher and tutor with experience of operating in schools in a number of roles was an advantage, inasmuch as it gave me insights, easy access and familiarity with being in classrooms as an observer and recorder. It did mean however that I might slip into roles such as teacher, adviser, helper or evaluator unintentionally, or be perceived as such by pupils. I presented myself as a colleague of their teacher, interested in the science work, and there to find out about it; I avoided teaching or disciplining pupils and was not in fact faced with the dilemma of whether to intervene in extreme cases, for instance in the interests of safety. My involvement extended to talking with pupils and being interested in their progress and problems. They came to accept this role and my recording of activities and talk; their views on this were sought at intervals and are reported in context in later chapters of the case. The account of the situation in Chapter 6 gives details of the teacher, myself and the pupils, and the way in which the sample of target pupils was generated from the agreed framework for the study. It was impossible to observe all the pupils in any detail and the focus was to be on the teacher, so we agreed a procedure for tracking his interactions with them individually or as a part of the whole class. Four pairs of pupils were observed initially and this was focussed down to four children who are described in detail in the study.

Sampling decisions have to be made in qualitative studies on grounds appropriate to the methodology and the research

questions, rather than left to chance. The notion of theoretical sampling, derived from Glaser and Strauss (1967), can be used to support an approach whereby early analysis generates theory that guides the later selection of data (Burgess, 1984b), but decisions have to be made at the start of a study on sound grounds. In this case those grounds were the style and concerns of the investigation, qualified by consideration of what was possible for one researcher with some four days a week for one term available and no funding. It was crucial to trace the teacher's thoughts as they developed over time in relation to the classroom action. The sampling of that could not be determined in advance on any sound theoretical basis and it was therefore necessary to observe all lessons connected with the science topic under study, until such time as the analysis indicated grounds for selection. In the event almost all lessons were observed over the term. This was in part due to the customary reluctance of a fieldworker to miss any possible significant data. Accounts by those who have made the journey through a long case study reflect their concern about missing data and the corresponding problems of grappling with data overload (for instance Ball, 1984; Hammersley 1984). In this study there was much redundancy in the evidence of the fieldnotes. However this can only be said with hindsight and there were many events which did not seem significant at the time that subsequently proved useful in analysis or writing. More fundamentally there is an argument that participant observation cannot be replaced by brief encounters, however carefully those are planned (Atkinson and

Delamont, 1986). Being there is important for the researcher and to those being researched. The focus of the study, on the teacher's practice and thinking and on tracing the relationships in this, required my presence in the classroom to witness events and record the teacher's perceptions. It was necessary to know what the teacher's references meant by having experienced them and being able to empathise with him. This meant that his comments out of lessons made sense in relation to his teaching.

When in school I observed, recorded, avoided judgemental remarks about the practice we were studying, but sought information with which to extend and check the description. It was easier to stick to a role in lessons than in informal contacts where social chat and shared professional concerns were also involved. When the teacher was working with the class I sited myself to see him and the pupils he was involved with, scanning regularly to monitor the children we had identified as a sample. On the occasions when he talked to the whole class, or I was using a video camera, my position was usually near the desk, out of the line of eye contact between pupils and teacher; later, when the class was more accustomed to it, a little videorecording was done from the corner by the window where a better picture was possible. Figure 2.1 locates these activities on a plan of the classroom.

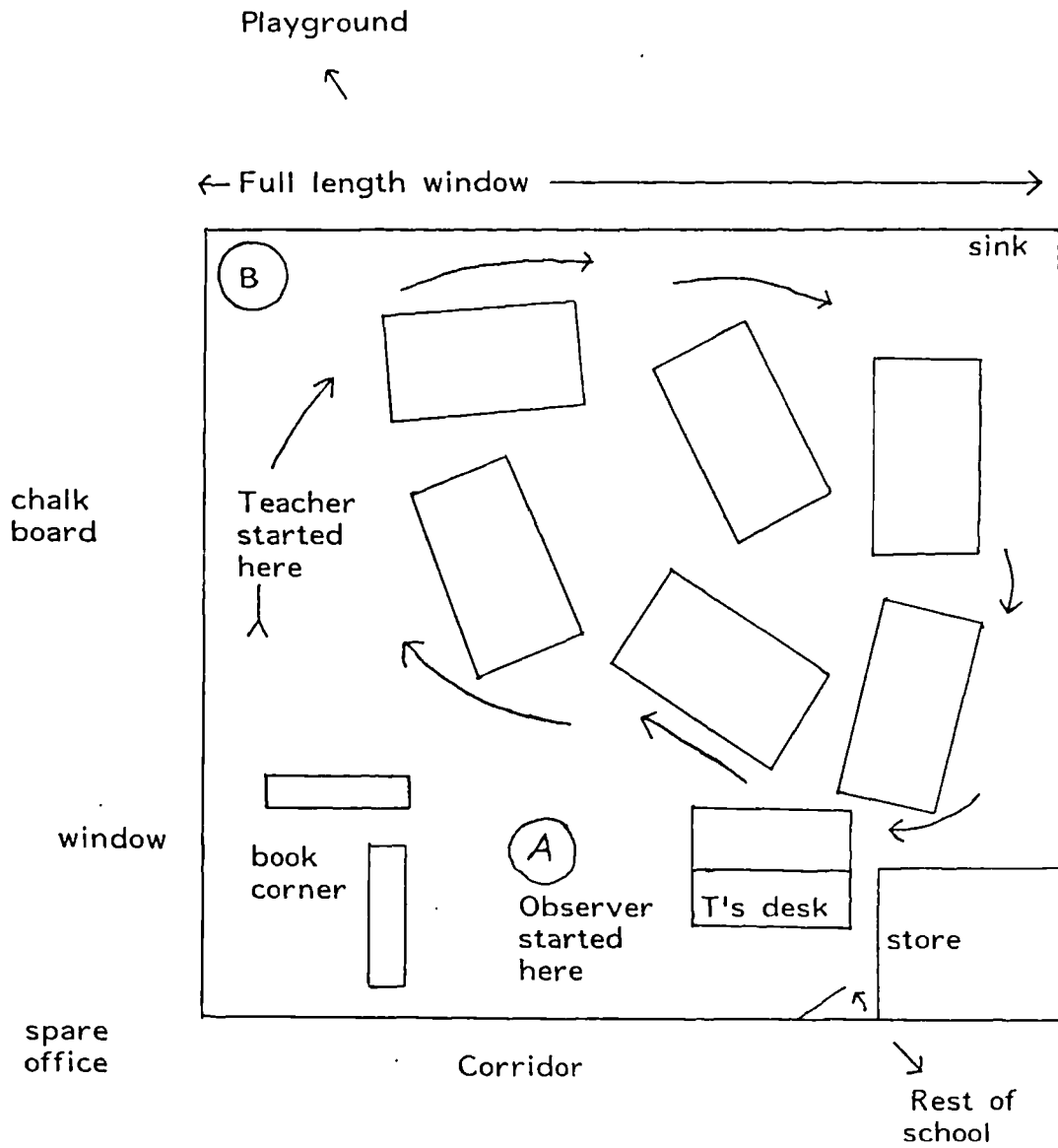

Figure 2.1 Classroom plan showing common starting point for observations and initial movement of teacher. (Observations begun at A. Some done later from B.)

Most of the lesson time involved pupils actively working around the room, and outside, with the teacher circulating. I traced this movement as necessary, and sought to merge into the fluid activity of unpredictable, pupil-centred lessons. This was not as difficult as it sounds; I had practised 'in situ' in the preceding term as well as drawing on years of observing students and pupils in primary classrooms. That experience also helped with the keeping of notes. Fieldnotes were made on file paper, with broad margins for comment and later coding. The early notes were guided by the framework generated from the teacher's plans and priorities and the underlying model of teachers' thinking, but were also very open as examination of the data gathered at this stage was expected to shape the later collection. They also served to provide contextual material and points of reference for comparing to later action or comments by the teacher. The teacher's actions, interactions with pupils, details of activities and progress with tasks were included, with timing and events that served as markers for comparing with other data. The teacher's talk with the whole class and the target pupils was audiotaped, using a small cassette recorder which he attached to his belt as he toured the classroom. This gave the optimum audiorecord of his interactions in the unpredictable and sometimes noisy lessons. Writing up of fieldnotes at the end of a day was accompanied by replay of the audiorecord and production of a summary on card. This was done after each visit to check the record of each lesson, and as a control on the quality of the

data. On average visits were made two days per week over the summer term and twice this time was available for the preparation and work on the data collected. Appendix 2 includes an example of fieldnotes and the index later made of the corresponding record of the lesson. Margins were used for cross references to other data on the same lesson, preliminary categorising and comments and memos, and references to data collected at other times in which themes could be traced or interpretations checked. The process of reduction and analysis is described below, including this triangulation of different data sets, but first the collection of that other data is discussed, beginning with interviews.

2.6.2 Interviews

Interviews and other conversations with the teacher were the central source of data on his thinking.. The term interview can refer to a range of encounters: highly structured, formal settings where the interviewer has control over the questions and form of response; more flexible, but planned, situations where there is some structure or focus; and informal discussions over which the informant has control. The latter can be extended to include spontaneous comments and incidental conversations. In structured interviewing information is sought from respondents and analysed in a framework that can be predetermined. It was inappropriate for the purposes and style of this study, although there were times when simple information was needed and direct

questions could be put. The semistructured interview, where the researcher has an agenda of concerns to act as a check list during conversation, was the starting point for my planning of interviews with teacher and pupils. The case for this was based on the relationship which was being established; the need for the flexibility to pursue any themes identified as the study developed; the focus of the investigation on the teacher's thinking and his meaning; and the opportunity for him to explore and make explicit that thinking. I would allow the teacher or pupil to take control of the interview while seeking to cover issues which I had anticipated. In terms of the contrast used later by Powney and Watts (1987) the interviewee was being treated as an informant rather than a respondent.

There are several risks in this approach. First it can easily become an excuse for lack of rigour and a haphazard style of interviewing. Second it can ignore the peculiar features of an interview and its purpose, seeing it as simply an extension of the equal social exchange of a conversation. Third it can lapse into talk unconnected with the research questions, and produce bulky material which cannot be analysed. Fourth it may fail to probe beneath surface accounts, or check on reports.

Interviews with the teacher were conducted in a relaxed setting at my home away from the immediate pressures of school. Our meetings involved some other business, such as making arrangements for classroom observations; outside the hour or two

devoted to that and to the interview some time was available for socialising. The teacher and I had first met some years before; our shared experience assisted with the rapport and trust essential to interviewing, but did carry risks. For example, assumptions might not be made explicit or probed. It also exaggerated the tendency to slip into a more natural conversational exchange. Listening to the earlier interviews and reading the transcripts, led me to be less intrusive during later interviews and to distinguish more clearly the eliciting of the teacher's thoughts from the practical or social functions of our meetings. However the early interviews were necessarily concerned to establish relationships, to agree frameworks and procedures for the research, and to create a dialogue in which the teacher could provide an account of his thinking. Denscombe (1983) has argued that such interviews, if sensitively handled, may stimulate informants into describing and justifying their opinions, activities, and the interpretation of events, thus demonstrating the reasoning involved without damaging the naturalness of the setting. Planning for each interview included the preparation of headings reflecting the main themes in the study and, increasingly over the year, of probes arising from earlier interviews or conversations and interviews. This agenda was used as a private check list, from which questions were raised if the topic did not come up as the teacher talked.

The main headings of my agenda were:

- a) Practical Arrangements
eg dates and times for visits; recording arrangements;
resources; collecting products.
- b) Methodological Matters
eg ethical framework; data clearance; research procedures;
reflexive effects
- c) Information to Collect or Pass on
eg contextual detail; events; pupil details.
- d) Issues and Aspects of Thinking in the Working Model
eg situational features and influences; teacher's plans -
long and short term; teacher's views and theories;
teacher's thoughts relating to particular
lesson/incident/pupil;
- e) Matters arising from previous interview / discussion / other
communication / observed events or other data.

Six planned interviews were held with the teacher over the year of the study. Table 2.2 locates and summarises the six interviews. Details of these and of unplanned conversations are provided in Appendix 3. All the planned interviews were tape recorded. Some supplementary notes were made when necessary to contextualise a remark, or at those times when the tape was not running and the teacher volunteered his thoughts. Normal face to face contact with minimum distraction was the goal and the tape recorder was largely ignored after its use at some preliminary

meetings. Tapes were summarised on a card when I listened to them shortly after an interview, subsequently transcribed at a first level and eventually in full. The early transcriptions were fed back to the teacher, as were notes made on less formal conversations, without any comment or interpretation. He chose sometimes to respond to those in notes or at a later meeting, elaborating on a statement or reporting on developments in his thinking or the situation. This provided some productive checks and insights, as indicated in the case study, but care was needed to avoid judgements and to recognise this as another way in which my involvement influenced the case. However it was consistent with the expectation that the teacher would gain from involvement by having an audience for his reflections. His comments on this are noted in Chapter 14. A further principle of our agreement was that this data would not be lodged in my case record until he cleared it. This ethical stance has its risks if informants veto valuable material, or the database becomes selective. As it happened the teacher only requested one small omission where he felt he had personalised a comment, although like many people reading their first transcript he was at first concerned by how inarticulate he sounded. In fact he was a fluent and open informant who spontaneously explored his thinking and reflected critically on the account he provided at interviews and in many comments and conversations that were not planned.

The six planned interviews traced the teacher's thoughts from his earliest intentions at the start of the school year through to

TABLE 2.2 OUTLINE OF SIX MAIN INTERVIEWS

Date and stage of study	Interview	Summary of Content
12/10/83 Autumn term, early in school year	First main interview	Negotiation of procedures, Teacher's plans for year, his underlying theories, Situation
20/3/84 Spring term, a month before Easter holidays	Second main interview, last before 'Toys' topic introduced	Clarification of teacher's plans for summer term and of research procedures. More situational details
12/4/84 End of Spring term	Third main interview, following an introductory lesson on 'Toys' on 10/4/84	Teacher's planning and theories. Roles, sampling and data collection confirmed
2/5/84 Early in Summer term	First interview during summer term. Followed lesson of 1/5/84	Teacher's recall of lesson, his plans, views on primary science. Links between thinking and actions
27/5/84 Summer half-term	Interview half-way through the topic	Teacher looked back and ahead, reflected on plans and theories in relation to the action, discussed dilemmas. A rich transcript for analysis
24/7/84 At start of summer holiday, end of school year	Final interview after topic completed and term finished	Teacher's final evaluations and reflections, and remaining background information collected in a more structured interview

the beginning of the holidays following the summer term's science topic. The first three, in October, March and April, focussed on his longer term planning, beliefs and theories, and explored methodological matters; the framework of his goals and strategies for the summer term was identified and the protocol for the research agreed; contextual information was collected. The first interview in the summer was held early in the term, the day after a lesson had been observed. A full transcript of that interview is included in Appendix 3. The teacher began by talking about that lesson, and a videorecording stimulated further comments. He rehearsed his plans, and provided insights into his views of primary science, as well as reflecting on issues arising from the lesson. When we met for a second interview at half term he could look back and forward, reflect on his developing plans in relation to the action, and on some of the dilemmas that emerged. He elaborated on his own theories and beliefs. A full transcript of that interview is also included in Appendix 3. At the final meeting, just after the term finished, a more structured interview ensured that information and opinions were collected and the teacher provided his overall evaluation of the project.

During the summer term there were many conversations initiated by the teacher before, after, or between lessons, and occasionally on journeys to and from school or over the phone. These were all noted down at the earliest possible moment, sometimes on the basis of a written or taped record that had been possible. These

are all summarised in Appendix 3. During lessons the teacher also made comments to me which were recorded with the field notes. This talk often related to classroom action or to his thoughts reported in other conversations and interviews. The variety and extent of such data allowed for cross-checking between verbal reports made at different times and in different circumstances. In analysis, and in reporting them for this study, the circumstances were noted. The volunteering of similar statements in a variety of natural settings can be seen as enhancing their significance, even if they are elicited and reported in less controlled circumstances than a planned interview. In many cases the teacher was able to elaborate on, or qualify, hurried comments later in written notes or at the more systematic interviews. It was possible to trace the development of the teacher's thoughts on a theme, or to hear him review his own report.

Interviews and conversations with the teacher could not have been so fruitful without the accompanying participant observation. Being there and sharing the experience was crucial, not only for subsequent triangulation of data but also to create the conditions in which the interviews could be productive. This was true at an even more basic level when it came to pupil interviews. The activities, progress and problems that the children had experienced and I had witnessed gave us a shared subject to discuss; my interest was more genuine and convincing because I had been present. Even so there were more problems in interviewing pupils than the teacher, as was expected. The main challenge remained that of stimulating a relevant account by

children while putting them at ease. Some of the problems noted by Simons (1981), for example relating to status and role expectations and setting, were expected. The target pupils and their different responses are introduced in Chapter 6, and traced in the context of the study in later chapters. Early conversations were held in the classroom as they worked, establishing interest and allowing the children control of the talk. Later interviews moved to the office adjacent to the classroom or to the staffroom; the children were asked if they were willing to come and talk, and declined to when they were busy. With their permission our conversations were tape-recorded. My preparation included attention to the setting, the building of rapport, verbal and non-verbal strategies, and the subjects I hoped to explore. I sought pupils' views on my role and influence, as well as on the substantive issues derived from the study of the teacher's thinking. The chief purpose of the interviews was to seek their perspectives on their teacher's thinking and practice, through comments on the term's plans and activities. The task in hand and recall, or replay, of earlier activities was the reference point for our conversations. Pupils' feelings and interpretations were valued. All the children were invited at the end of term to view themselves at work on a hastily edited video and to comment. However the four target pupils were interviewed at the start and end of term, and twice in between, with other less formal meetings and many incidental conversations. The results varied, but even the least forthcoming provided relevant and extended comment and showed

insights into their teacher's thinking. The children's accounts could be set against his reports, my observations, and the results of their work which were collected along with other documentation.

2.6.3 Documentary Evidence

Curriculum documents, pupil products, plans and other writing by the teacher were collected to supplement the main data gathered from observation and interview. These were not solicited specifically for the research, but we agreed that a copy would be made of any written materials referred to or produced in connection with the science topic. The teacher made some written plans and evaluations, and occasionally wrote comments directed to me, but was not asked to add systematic diary keeping to his workload. It would have imposed a further burden and not been consistent with his normal practice. The writing he did was copied, producing a varied collection which could only loosely be termed a journal. However evidence relating to his thinking and practice from documents was useful to set against the observations and accounts, serving as a comparison and check. Its use is illustrated in the case study - for instance, in Chapter 7 the teacher's reference to a document produced for in-service work gives insights into his theories, and in Chapter 8 his plan for a lesson is included. Pupils' work over the summer term was collected in the form of their rough notes in jotters, completed writing and drawing, and evidence of the

progress of models from photographs, videorecording, or sketches I made. Much of this was useful for other purposes but redundant for the final analysis. However it was important for checking my notes during data collection, for relating to the pupils' and teacher's talk, and for giving substance and contextual detail to the final account in Chapters 9 to 12.

2.7 Methodological Decisions Through the Study

Throughout the study methodological memos were kept which themselves became a source as analysis proceeded. The history of the study was carefully logged along with my commentary. Methodological issues and decisions as the study developed over a year are summarised in the flow chart in Appendix 5. This was drawn up late in the summer term, on the basis of memos made at each stage of fieldwork, to capture the process at the time.

Before the first entry to the school site there were a number of overlapping activities involving definition of the problem, identification of the site, and agreement of access and procedures, which have been introduced in Chapter 1. After the fieldwork was completed there was an intensive period of checking records, transcription, and organisation of material. Then the long, iterative process of analysis had to be done intermittently outside my normal workload. The extent of the data and my commitment to deriving the explanations from the case required lengthy immersion and movement back and forth between sets of data.

It has already been noted that analysis in case study overlaps with data collection and informs that during the stages of fieldwork. The reduction of data begins in a sense before a study, in the sampling and methodological decisions made at the start, and continues through and beyond the collection stages. The flow model outlined by Miles and Huberman (1984) provided a concise representation of this which is related to the development of the analysis in this case in figure 2.2.

The earliest reduction of data and tentative identification of analytical categories derived from the working framework for the study as described in Chapter 4. The concern to investigate relationships among the elements of the teacher's thinking and practice required that his plans, decisions and more general theories were identified in his statements and cross-referenced to his teaching. The aims and strategies he had confirmed as his priorities for the term guided the initial notes and organisation I made of observational data. Review of this at half term, and then at the end of the period of collection, led to the development and sharpening of categories which were used to code the data (see Appendix 7). These were used to inspect a range of data and applied in detailed analysis of interviews, then modified by collapsing some categories which were too fine and introducing others where data was not categorised. At the same time more interpretative analysis of interviews was undertaken,

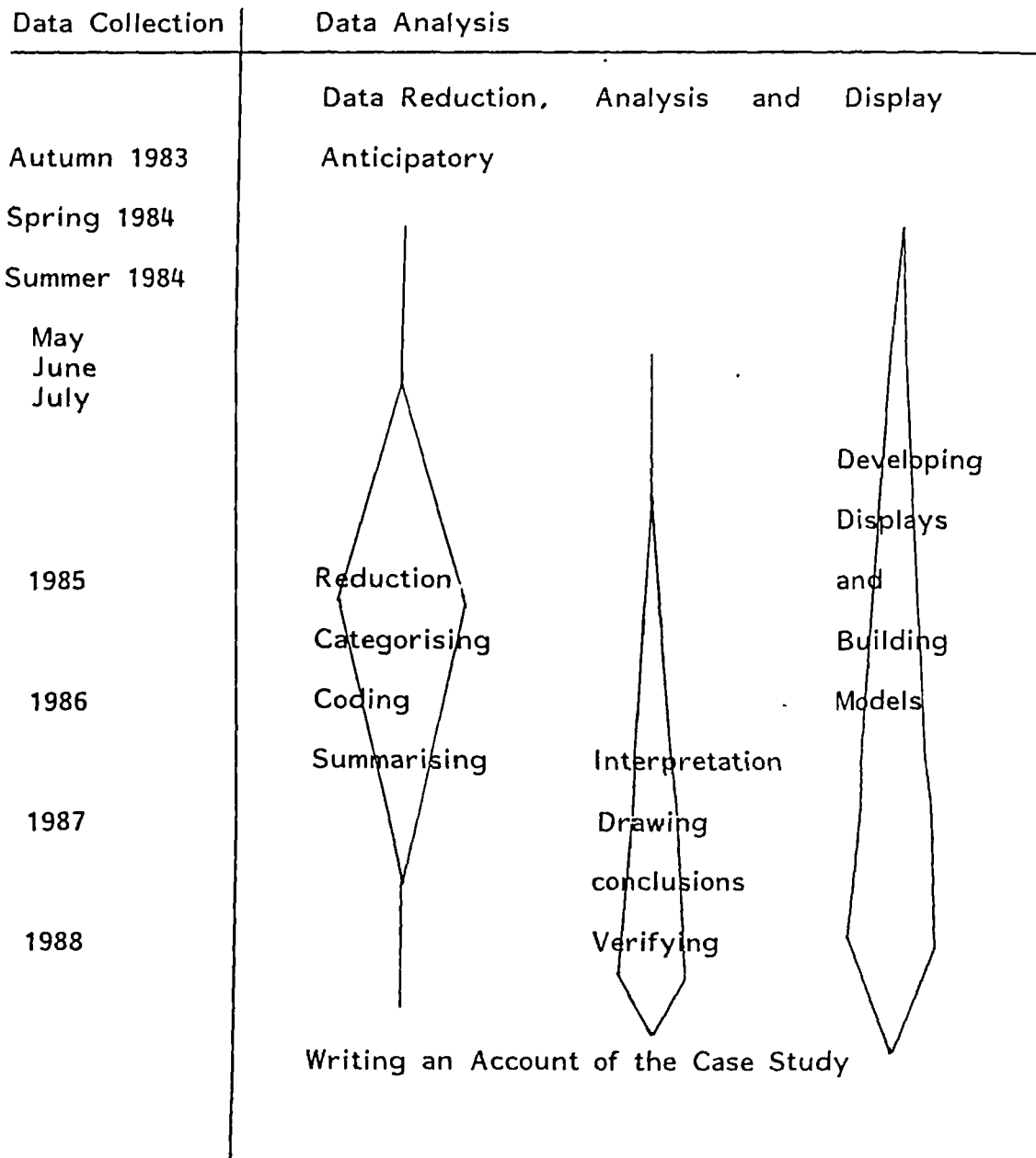

Figure 2.2 Flow of analytical activities (based on Miles and Huberman, 1983, fig 1a)

and reading across data sets traced preliminary interpretations of the case. This stage of immersion in the data and iterative analysis produced draft materials which teachers, colleagues, and research supervisors could comment upon. The rereading of these alongside analytic memos and the growing literature on teachers' thinking was the final stage before systematic reanalysis of the data. This was done, starting with the transcriptions of interviews and other conversations, as summarised in Appendix 8. The units of the topic represented in Chapters 6 to 12 of the final account were separately analysed, working from the interviews to the other relevant data, then moving between data sets. The final account seeks to provide a thick enough description and range of data to support the analysis in each chapter. The relationships between aspects of thinking and practice were traced through the chapters. The analysis of dilemmas derived from the data proved productive for this; there were precedents for using dilemma analysis in the study of teaching, (eg Berlak and Berlak, 1975; Winter, 1982), and specifically in research on teachers' thinking, as reviewed in Chapter 3. A small number of concepts was derived from and tested against the data (eg the repertoire of knowledge upon which the teacher drew in planning). These were used in the interpretation and the construction of a more general model of teachers' thinking which can be compared to the literature and to other cases. This process is conveyed by Miles and Huberman (1984) in the metaphor of progressively moving up from the empirical trenches to a more conceptual overview of the

landscape. They note the risks in such steps, the need for clear linkage to the conceptual framework and research questions, and the importance of repeatedly moving back down the abstraction ladder for concrete instances.

Table 2.3 summarises the stages of the analysis and some of the checks which were made as the data was collected and processed.

2.8 Questions of Validity: Checks on Data and Analysis

In the field of ethnography, case study, and qualitative research generally, appropriate tests of the quality of data and the rigour of analysis are necessary. Parallels and contrasts with tests of validity and reliability in the experimental tradition have been drawn (for example see Goetz and LeCompte, 1984, on ethnographic quality control; Guba and Lincoln, 1981, on tests of rigour in naturalistic inquiry; Miles and Huberman, 1984, on dealing with bias and validity in qualitative research; Yin, 1984, on validity and case study).

Guba and Lincoln (1981) argued that research and evaluation have to meet tests of rigour relating to the truth value, applicability, consistency and neutrality of their analysis and findings. Within an experimental tradition of research these can be associated with the terms internal validity, external validity, reliability and objectivity. However the distinctive character, methodologies and purposes of "ethnographic studies"

TABLE 2.3 STAGES IN THE ANALYSIS

ANALYTICAL STAGES	CHECKS ON VALIDITY
During data collection - cross checking, coding, notes in margins & files, plus cross-references and comments	Quality control by myself Teacher's comments on authenticity
Data reviewed -> more focussed collection and analysis	Cross-checking between data sources
After data collected - case record cleared and organised. Material shared with others	Feedback from teachers in group, & others
Read through, seek patterns, revise framework & categories Detailed analysis of transcripts Work from interview analysis to summaries of other data, back/ or to other data where necessary	Keep memos & stay close to data. Analyse in alternative ways, repeat 'blind' later. Get others to inspect transcripts & analyse sample
Draft accounts to try out first interpretations	Read by supervisors
Read all comments. Relate to literature. Redraft	

(Goetz and LeCompte, 1984) or "naturalistic inquiries" (Guba and Lincoln, 1981) make it inappropriate to simply adopt those concepts and the associated procedures from the experimental tradition. This does not relieve researchers in these alternative traditions from applying tests of rigour but rather points to the importance of developing arguments and methods consistent with their paradigm. Goetz and LeCompte discussed threats to validity in an ethnographic approach and indicated ways these can be met. Guba and Lincoln discussed concepts and terms appropriate in naturalistic inquiry which would be the equivalent of those scientific terms noted above from the experimental tradition. They proposed that naturalistic studies should meet tests of credibility, fittingness, auditability and confirmability, suggesting checks which could be used for each.

Criteria and standards suitable for case study were noted in section 2.2 above. Those criteria of credibility, transferability, dependability and confirmability were informed by Guba and Lincoln's proposals (Bell, personal communication). They were adopted in this study to guide the checks made on collecting, analysing and interpreting data. Miles and Huberman's detailed discussion of qualitative analysis offered useful tactics for checking the quality of data, findings, and explanations.

The checks used in this study drew upon these developing traditions of more rigorous qualitative research. For example

during fieldwork my extended presence alternated immersion and detachment, and regular checks were made on the effects of my presence. Volunteered statements by the teacher were collected and confirmed and compared over time. Different types of data were collected and triangulated, and so, to a lesser extent, were different perspectives. Premature closure or imposition of a model was resisted and alternative interpretations considered. Throughout analysis reference was made back to the data, looking for negative evidence as well as more detail. Feedback from the teacher and from others able to comment critically on findings and explanations was arranged. Finally the report was written to include as much evidence of data and analysis as possible within the thesis. The organisation seeks to provide sufficient access in the text and appendices so readers can exercise their own judgements as to its dependability, confirmability, credibility and transferability. This chapter has explained the reduction and analysis which generated this report, and examined related methodological issues. The next chapter discusses the substantive literature which was reviewed as the study was planned and conducted.

CHAPTER 3 REVIEW OF LITERATURE ON TEACHERS' THINKING AND PRIMARY SCIENCE

3.1 Introduction: the Scope and Sequence of this Review

This chapter deals in turn with the two substantive fields of literature relevant to this study: primary science and teachers' thinking. Both have grown rapidly in recent years and display the diversity characteristic of newly developing research areas. A number of current concerns in primary science were of particular relevance to the present study; for instance the relationship between process and content, and the use of problem-solving approaches. The introduction of design-technology and the emphasis on activity and process learning in the present case reflected contemporary positions in primary science. The section on primary science in this chapter opens with a review of recent developments to set the study in context. Then literature concerning views on the nature of science and its learning in primary classrooms is reviewed. The section on teachers' thinking begins with an overview to conceptualise the field, and then aspects of thinking distinguished in the literature are considered in turn. Models of thinking, and the relationship between aspects of thinking and classroom practice, are reviewed.

3.2 Primary Science: the Background and Contemporary Developments

Science teaching in primary classrooms has been the subject of a series of curriculum development projects in the UK over the last two decades (Nuffield Junior Science, 1967, Science 5-13, 1967-80; Progress in Learning Science, 1973-80; Learning Through Science, 1980-85). In the USA there have been a number of curriculum projects and initiatives on an even larger scale. Martin (1983), comparing several publications and projects in elementary school science, illustrated their different priorities. Many were concerned to promote active inquiry by pupils. Despite the scale of these efforts the evaluation of their impact on the quantity and quality of science teaching in elementary classrooms was revealing a disappointing picture.

Similar evidence emerged in other countries. For example in the analysis done for the Science Council of Canada's study of Science and Education (Orpwood and Souque, 1983) all the guidelines from the Ministries of Education in Canada were found to include aims relating to science content, skills and attitudes. However the authors of two of the case studies undertaken as part of that study were led to conclude that in elementary schools science was still "a little added frill" rather than an important curriculum focus (Schoeneberger and Russell, 1986).

In the USA, Project Synthesis collated studies of the state of science education and of pupils' performance. It specified ideals or goals for science education, referred to as desired states, and compared these with the actual states revealed by their findings. Summarising some of the findings for Elementary Science, Johnson (1983) noted

the discrepancies between desired states and actual states were numerous, and in some instances dramatic; clearly efforts over the last 20 years by science educators, scientists, and child psychologists to make science in the elementary school more appropriate largely have been ignored (p7)

Among the discrepancies Johnson highlighted was that between the desire to give children real alternatives, real problems and concrete materials, and the evidence that didactic teaching using textbooks was the commonest pattern. Although the reliance on textbooks and absence of first hand experience might seem inconsistent with the British primary school tradition, the evidence of surveys here was equally disappointing. A major landmark in raising awareness of this was an HMI survey published in 1978 which identified science as an area of concern in primary education.

The progress of science teaching in primary schools has been disappointing; the ideas and materials produced by curriculum development projects have had little impact on the majority of schools. (DES, 1978, para 5.82)

In making this judgement HMI noted how little evidence they had found of teaching that extended pupils' skills, developed

investigations started by pupils, and broadened their understanding of physical science. They diagnosed the major obstacle to progress as the lack of appropriate knowledge among teachers, and proposed steps to improve this, including the careful deployment of teachers who did have such expertise.

By 1984 a survey of science teaching (Keys, 1987) found that 99% of English schools taught science to ten year olds, on average for one hour per week. A fifth usually favoured a topic-based approach, two fifths normally taught it as a separate subject, and about 6% as it arose from children's interests. However some 30% gave equal emphasis to more than one approach. The report indicated that practical work, use of small groups, and some control over their own learning were experienced by many pupils, but with considerable teacher direction. Teachers with a science background tended to devote more time to practical activities. Two thirds of the teachers of science were general class teachers.

The subsequent national initiatives and the growth of primary science are not the focus of this study, but the changing educational climate and the knowledge base of the teacher in this case are relevant. The content and character of science education became a matter of national policy (DES 1985a) and science was included as part of the core of the proposed national curriculum (DES, 1987). These political and educational currents had already started to flow at the time of this study. For

instance the teacher voiced his concern over the implications of the mounting pressure for subject studies in primary education reported at the time (Bolton, 1984). He held beliefs about the primary curriculum which were in tension with his specialist expertise and role. He was in fact one of the 10% of teachers of science to 10 year olds in 1984 who had studied science as the main subject in a degree or training course (Keys, 1987, p44). He held a post in his school involving consultancy for colleagues in science and mathematics.

The tradition within which the teacher worked favoured integration of the curriculum, use of the environment and pupils' interests. The inclusion of disciplines such as science within topics, through incidental teaching, or from experiences based on the local environment, needs to be planned with reference to a framework of scientific learning. Even in the enthusiastic support for flexibility in the curriculum from the Plowden Report there was some recognition of this (Central Advisory Council for Education, 1967, para 539). Twenty years later the interim report of the National Curriculum Science Working Group emphasised that schools and teachers are responsible for decisions about whether or not to organise the learning in an integrated way, but that whatever form is chosen planning should ensure that children have experiences which allow them to progress in their science learning (DES, 1988a, pp38-9).

The whole pace of the debate over primary science was

dramatically accelerated by the proposals for a national curriculum. Many of the issues to be reviewed here crystallised in the programmes and attainment targets recommended for ages seven to eleven. The incorporation of technology with science; the relationship of concepts, skills and attitudes; and the integration of those subject concerns with a view of learning all featured in the working party's interim recommendations concerning seven to eleven year olds (DES, 1988a, ch6). The final report of the working party (DES, 1988b) included a component on technology in the primary stage. Although responsibility for this programme was then transferred to the Design and Technology Working Group in practice primary science was rapidly accomodating technological activities.

3.3 The Growth of Design, Technology and Problem-solving

The association of technology with science in primary schools has perhaps been the most rapid of the many changes since this study began. In fact there had long been a tendency for primary schools to relate the study of subjects to human needs and to work in an open-ended way on practical problems. Evans (1980) had described his introduction of more technological and design-oriented work at junior school level. In this study the teacher's view that primary science should be applied (sic) are examined in Chapter 7. He introduced activities and approaches which primary schools were just beginning to adopt enthusiastically under the headings of craft, design and

technology or problem-solving. One of the techniques was derived from the author of a book which epitomised the contemporary influence of design-technology (Williams and Jinks, 1985). There was growing support from outside schools for the incorporation of design and technology into primary science and the broader curriculum, subsequently represented by reports from two bodies involving industry and education (Engineering Council/SCSST, 1985; Design Council, 1986). Interestingly those reports advocated the group work and integrated approaches of primary classrooms just as it was becoming subject to criticism from within education.

An approach to cross curriculum studies in many primary schools based on problem solving has been introduced only recently in a number of schools. It has been introduced not as a new subject but as a way of teaching which crosses subject boundaries and is already at the heart of good primary practice. (Engineering Council /SCSST, 1985, p13)

Earlier arguments for problem-solving identified it closely with science or technology. The Nuffield Junior Science Project (1967a) suggested that children's practical problem-solving is essentially a scientific way of working. The distinctions between design, technology and scientific investigation have frequently been blurred or the close relationships been stressed (for instance in Gilbert, 1987a)

3.4 Views on the Nature of Science and its Learning

At the time of this study a major source of discussion in primary science was the paper by HMI Science Committee (DES, 1983a) whose

recommendations were later incorporated into a statement of national policy for science education (DES 1985a, paras 18,26). The opening section of the HMI discussion paper stressed the match between "the intellectual processes of science" and "what we know of how children best learn". This equation, and the emphasis on process, was a familiar position in primary science and one that teachers responded to positively. However the argument in the paper for attention to content and scientific ideas had been advanced less often, and primary teachers were more resistant to statements such as "a strong case can be made for deciding upon some common content and for devising a scheme that prescribes content" (p7). The teacher in this study wrote "very contentious" in the margin of his copy next to that statement. The contested nature of primary science at the time of this research was conveniently represented in the collection edited by Richards and Holford (1983) which the teacher began to read toward the end of the study. Richards noted how the most contentious issue had been the relative importance of process or content criteria in planning primary science, contrasting this with the near unanimity over psychological principles. The literature concerning the arguments over process and content, and the related views of science and learning, is reviewed here.

Policies, curriculum materials, and teaching practices in primary science are underpinned by views on the nature of science and learning. Where these are made explicit the two are often closely identified, as in the quotation from HMI above. Implicit

in the didactic teaching which surveys showed still to be common was a view of science as firm knowledge and theories from which deductions were made and tested. The opposite, inductive, view of science as proceeding from particular observations to more general knowledge using scientific methods or processes had influenced curricula from the 1960's. Critiques of popular views on the methods of science, and analyses of how scientists operate in practice, were available (for example in Medawar, 1967) and the contention among philosophers and historians of science was represented in some collections for teachers (eg Jenkins and Whitfield, 1974; Squires, 1976; UNESCO, 1980). However there was little evidence in primary science of awareness of the arguments. Most published sources and policy statements on primary science were based on an idealised picture of the nature of scientific activity. They also often reduced the methods and processes used by scientists to a simplified notion of "the scientific method" or "the scientific process". A representative statement was to be found in a source used by the teacher during this study.

First and foremost, science is a way of finding answers - a method of thinking and doing - how the answers are found is known as the method of science

(Gilbert and Matthews, 1981-1984,p8).

The emphasis on process in primary science reflected a move away from factual learning to the fostering of skills and attitudes which was at the heart of curriculum development projects such as Nuffield Junior Science (1967a) and Science 5-13, which defined its overall aim as "the development of an enquiring mind and a

scientific approach to problems" (Ennever and Harlen, 1972,p21). The move implied a shift from a deductive to an inductive view of science, noted by Harlen (1985a, p10) who went on to argue that primary science now needs a more realistic view which recognises that scientific activity is neither purely inductive nor deductive. The case for process science is often based on its supposed reflection of the nature of science, and also of pupils' learning. Millar and Driver (1987), reviewing the evidence from the philosophy of science, demonstrate that it is not possible to identify specific scientific processes, and also argue that a process view of learning is not consistent with what psychology now has to say.

However the argument that "what is taught to children should resemble what scientists do - the 'processes' that they carry out in their own scientific activities" (Gagné et al, 1967) had a strong influence on the philosophy of British primary teachers even if it was rarely attributed to the American project, Science - a Process Approach (SAPA), from which that quote comes. SAPA explicitly mentioned that an emphasis on process implied a corresponding de-emphasis on content. In policy and practice this was to be the trend in the years leading up to the present study. An early exception to this was the work of the Oxford Primary Science Project (Redman et al, 1969) which saw science learning as the accumulation of experiences leading to the formation of scientific ideas, under four major headings of energy, structure, chance and life.

It is possible to trace the development of the content-process debate as it readmitted discussion of content. Harlen (1978) suggested there were content objectives which could be seen as a set of ideas, generalisations and facts which children should encounter. The debate has moved from a position where the question "does content matter in primary science?" had to be posed (Harlen, 1978), to one where the concern is to explore the relationship between the learning of process and content. This began by seeing content as a vehicle for learning science concepts, skills and attitudes. Recognising that learning cannot be content-free and involves some process skills, it sought to articulate the role of those skills in concept building. The relationship between concept and process came to be viewed as one of interdependence (Black and Harlen, 1982; Symington et al, 1982).

The opposition of process and content had not provided a useful basis for practice; and the dichotomy between science as a means of acquiring skills and attitudes on the one hand, or as learning information on the other, was always a dichotomy in theory only, according to Kerr and Engel (1980). They went on to suggest that it would be more productive to look closely at how children acquire skills and attitudes as well as an understanding of essential concepts. It is necessary to review how primary science has analysed skills, attitudes and concepts before examining the psychological basis for its teaching of those.

3.5 Analysis of Processes in Primary Science

The term process is used in a variety of ways which can complicate the analysis of skills and attitudes. Skills involved in scientific activities have sometimes been labelled process skills, and allied to information processing models of learning (Harlen, 1985a,1985b). Tasker et al (1979) reported that teachers showed confusion over just what process skills were, using them to mean cognitive activities in problem solving, or manipulation, or even to include concepts and attitudes. It might be safer to speak of skills and attitudes, avoiding the term process, but that is now firmly established in the vocabulary of primary science.

Analysis of processes was carried out most thoroughly and publicly in Britain by the Assessment of Performance Unit (APU). Their assessments at age 11 (DES 1981,1983b,1984,1985b) were based on a framework made accessible to teachers in a Science Report for Teachers (Harlen et al, 1983b). Its summary emphasised the need to help children acquire specific scientific skills such as defining patterns in observations, giving explanations, predicting, hypothesising, controlling variables and planning investigations.

Other lists were emerging at the time, such as that referring to ages seven to eleven produced by the committee of the School

Natural Science Society, which was concerned about the adoption of the APU lists (SNSS,1984). It must be noted that the APU had stressed its categories were for testing purposes and that teaching should, for example, develop the different skills and ideas in unison. Published schemes were providing more or less detailed accounts of processes, often cross-referenced to activities. The teachers guide to the LOOK! scheme summarised the scientific process (sic) in a flow diagram and enumerated ten steps in the sequence which were systematically related to activities on the workcards of the scheme (Gilbert and Matthews, 1984, pp14-5). The workcards were one resource used by the teacher in this study. The Learning Through Science scheme, to which he also referred, was based on a broadly conceived set of processes for science learning that were not spelt out in detailed relationship to the activities until the guide for the series was produced later in the project (Richards, Collis and Kincaid, 1985).

Investigations by pupils and experiments by scientists can be analysed without claiming the two are identical. The distinctions are noted in the discussion of science skills in Longman Scienceworld, which presents teachers with a more realistic picture of the nature of scientific activities than the conventional view (Presst, 1987,pp104-5). Nor need analysis assume a necessary sequence in which processes are used and learnt. Harlen (1985a,p25) represents six main process skills in a form that deliberately avoids suggesting a sequence or

priority:

observation interpretation of information

hypothesising raising questions

devising investigations communicating

All the items are seen by Harlen as part of the total process of investigation, and all were witnessed in the present study. The teacher was particularly concerned with those which involved pupils in planning and pursuing investigations based on their own questions.

Detailed analysis of pupils' performance in planning was included in the APU monitoring, and later made available to primary teachers in their report on Planning Scientific Investigations at Age 11 (Harlen, 1986). The surveys showed that activities concerned with planning, controlling variables and making decisions about designing and recording observations were low on teachers' priorities. The evidence on children's planning showed that their performance fell progressively as they encountered later steps in the sequence of planning. This did not mean they could not carry out the investigation and pay implicit attention to such steps as controlling variables. But the complex picture did suggest that more attention should be given to explicit planning, linked with the implementation of such plans and their review in the light of those investigations. This emphasises the importance of practical investigation but points to the need to

make more use of that to encourage children to think as well as do.

A closely related issue has emerged with the growth of design-technology in primary schools, noted in the introductory section of this review. Emphasis on a linear design process involving pre-planning is found in curriculum material, such as that encountered by the teacher in this case (BBC,1982). Many variants of that appeared as a technological dimension was introduced into the primary curriculum (eg Williams and Jinks, 1985; County of Avon, 1985; Engineering Council/SCSST,1985).

The variations generally identify a starting point in some given or recognised problem, followed by a sequence of reviewing possible solutions, selecting and trying out a preferred solution, evaluating and perhaps modifying. Solutions often involve making and testing, and primary technology has been particularly concerned with this stage. Craft skills and the application or extension of scientific learning have been closely linked to the technological activities. The similarities to planning and carrying out scientific investigations have been stressed, but a few later publications have also noted the differences. For instance Johnsey (1986) prefaces practical advice with a comparison of scientific investigation and the problem-solving process of design-technology. He summarises the scientific process (sic) as proceeding from observations, through questions, to the design and carrying out of experiments which

may give results that answer the question posed. The problem solving process he summarises as flowing from the identification of a problem that needs solving to the consideration of possible solutions, one of which is selected for trial by making and modifying a device. Johnsey notes that it is helpful for teachers to clarify in their minds the distinctions even though they are closely connected in practice.

3.6 Analysis of Concepts in Primary Science

By the time of the present study primary teachers were already responding to the call for a more balanced science education, including experiences of technology and physical science to complement the traditional emphasis on biology (see for example the evidence of APU surveys in DES, 1984, p22). There was wide acceptance of the proposal that children in primary school should study living things, materials, energy and forces which was made by HMI (DES, 1983) and subsequently incorporated into Science 5-16: a Policy Statement (DES, 1985). However it was unusual for detailed concept maps to be included in the earlier published schemes available at the time of the study. The major exception was the LOOK! scheme which aimed to cover key scientific ideas in a balanced way, by basing the work on seventy one concepts (Gilbert and Matthews, 1981-1984). The APU had devised statements that formed the content base for their testing (APU, 1978). These were the basis for many proposed concept lists in later publications and policy statements. LEA guidelines

differ in the extent to which they specify concepts. Some have listed or analysed concepts in their policy statements, from Leeds (Squires, 1980) to Cornwall (1987). Others, such as the authority in which this study was conducted, did not favour such explicit lists and in any case emphasised processes.

The specification of concepts as a framework for knowledge and understanding in primary science within the proposed national curriculum, featured in the interim report of the Science Working Group (DES, 1988a, table 2). Although there is growing recognition by teachers of the importance of ideas as well as processes in the scientific education of primary pupils the finer conceptual analysis will not be easily incorporated into primary practice. The limited scientific knowledge and confidence with scientific ideas of many primary teachers is only one constraint.

The production of concept lists and arguments for a more structured approach to planning have clashed with a primary tradition based on an integrated view of the curriculum and a model of learning and teaching often associated with the Plowden report (see Gilbert, 1987b for an example of this clash). The final report of the Science Working Group (DES, 1988b) proposed thirteen attainment targets and related programmes of study around which primary schools will have to plan their teaching of scientific concepts. The report emphasised that this can be implemented in a variety of ways, including the use of integrated topics (p96-97). The practicalities of this and the resolution of tensions between primary traditions and a conceptual framework

for planning and assessing will be a major item on the agenda of primary schools into the 1990's.

3.7 Theories of Learning in Primary Science

The dominant model of learning in primary education at the time of this study was still Piagetian. Many acknowledgements to Piaget's work occurred in writing about primary science, from Isaacs (1958,1962), through the Nuffield Junior Science Project (1967a), to the modification underpinning Science 5-13 (Ennever and Harlen, 1972). Frequently reference was made to a general view about learning and the processes of science, as well as to concepts and stages of development.

The Plowden report's developmental emphasis was linked with Piaget's work (Central Advisory Council for Education, 1967, chapter 2 and paras 521-535). It also explicitly summarised the treatment of primary science in the phrase "learning by discovery" (para 669). That phrase conveyed several features of the psychological position underlying much primary science: the importance attached to pupils' experience and activity; the developmental view of learning; the unpredictability and individuality of concept acquisition; the value of questions and enquiries generated by the learner; and some uncertainty over the role of the teacher and language in learning. The Nuffield

Junior Science Project is often cited as the proponent of discovery learning, although the term is rarely used in its teachers' guide. It did however state several principles, such as the importance of experience and of active problem-solving, which it explicitly derived from Piaget (Nuffield Junior Science, 1967a, p22).

The first issue of a new journal for primary teachers in 1973 included a specific rationale for discovery science, alongside critiques and commentaries on the concept of discovery (Richards, 1973). Arguments over the meaning of the term 'discovery' introduced alternative psychological perspectives such as those of Bruner, Gagné and Ausubel. McClelland (1983) later advocated Ausubel's theory of meaningful learning and contrasted it with the dominant Piagetian tradition, emphasising the role of verbally presented material and the tendency to oversimplify Piaget's notion of action. The importance of language, the role of previous learning, and the structuring of learning experiences implied a more active role for the teacher. Work such as Donaldson's (1978) on Piagetian tasks indicated the effect of context on pupils' performance.

The Piagetian tradition, and emerging challenges to this were succinctly located at the time of this study by Richards (Richards and Holford, 1983, p7). The major features of a Piagetian position, in which scientific ideas are constructed rather than deduced, were summarised for secondary teachers,

along with a critique and a discussion of alternative psychological positions, in Driver (1983, ch6). The most important development has been the elaboration of a constructivist view of learning as a basis for science teaching. This stresses the influence of individual learners' existing conceptualisations and purposes on the meanings they construct as they seek to make sense of the world. It has been closely associated with the study of children's ideas and the implications these have for the teaching of scientific concepts in secondary education (see for instance Driver and Oldham, 1985).

3.8 Views on the Learning and Teaching of Concepts

Scientific concepts and logical structures were examined in detail in Piaget's original studies. Piagetian accounts of how children construct their understanding offered teachers insights into the acquisition of specific scientific ideas and a general position from which to view learning. By the time of the present study the investigation of pupils' construction of their scientific ideas had become a major strand in science education research, with particular potential for influencing practice, as noted by Kempa (1984). A number of terms had been attached to the ideas of pupils, such as alternative conceptions and frameworks, or children's science. In a contemporary article Osborne, Bell and Gilbert (1983) summarised their meaning for the term children's science and the ways it differed from the

generally accepted scientific viewpoints of scientists. By children's science they meant the views of the world and the meanings for words which children develop before they are formally taught science. They noted how young children tend to a self-centred, or human-centred view, of things and have difficulty with the kinds of abstractions and constructs scientists deal in. Children's interest in particular explanations for specific events contrasts with scientists' concern for more general, coherent explanations. They illustrated how children may hold views that are very different from scientists', and how difficulties in changing those to more conventional views may be compounded by our everyday language.

The work of Osborne and colleagues in the Learning in Science Project (LISP) has been a particularly rich source in this field, later to become more accessible to primary teachers in Osborne and Freyberg (1985) and Harlen (1985b). Some of the ideas which arose in the present case study, for example concerning force and motion, have been the subject of studies in LISP and elsewhere (eg Osborne, 1980; Osborne, Schollum and Hill, 1981; Stead, 1980; Stead and Osborne, 1980; Watts, 1983). Many used the techniques of interviewing pupils about instances shown in drawings. In the LISP studies for example children from seven upwards were asked whether they considered there was a force acting in each drawing, to probe for their own meanings of the term force. Frequently they revealed human-centred and non-Newtonian views, for example that force is in a body, and associated concepts of friction and

gravity that were at odds with standard scientific viewpoints. Despite variations between studies and a range of ideas among children it does seem that there are a limited number of alternative conceptions which commonly recur. Osborne, Schollum and Hill (1983) summarised their findings with regard to force, friction, and gravity. The influence of everyday usage of the term force, and its close association with action and movement, was evident. Friction was often associated only with movement between solids and identified with heat energy. Gravity was viewed by some pupils as increasing with height above the earth, or as absent above the atmosphere, and acting as a push rather than a pull. A significant number of children did express more standard scientific ideas however.

Such research can inform the practice of primary science. This will be more likely if teachers are themselves involved in studies of young pupils using appropriate methodologies. Practitioners can then gain insights into the ideas held by their own pupils and contribute to the wider knowledge base. They can also be involved in the exploration of appropriate strategies for working with pupils' ideas. There is as yet little evidence of the best ways to teach for conceptual change in the context of primary school science. The Primary Science Processes and Concepts Education Project (SPACE) is investigating pupils' ideas and teaching strategies with a number of teachers in the context of their normal classroom practice. The strategies include encouraging children to test their own ideas and to generalise

from specific instances (Harlen, nd). The application of such strategies will require primary teachers not only to extend their practice but also to examine their views about learning and teaching. The teacher in the present case engaged in such an examination. His reflections upon his views and on the ways in which he could use his own knowledge to extend pupils' ideas will be reported.

British primary practice can also learn from three curriculum development projects with a constructivist perspective working in different contexts. The Planning and Teaching Intermediate Science study in the USA modified curriculum materials and observed teachers using them (Smith and Anderson, 1983). It highlighted difficulties in teaching for conceptual change, including the cognitive overload experienced by teachers and the constraints of their own implicit theories which strongly determined their teaching approaches. In Britain the Children's Learning in Science Project works with secondary teachers on strategies for conceptual change. Teaching sequences based on a constructivist view of learning have been developed (see for instance Driver and Oldham, 1985). The extension of this work in a continuity project including pupils from 5 years old is involving primary and secondary teachers in the identification of pupils' ideas and the development of teaching approaches in one topic area as a basis for further work (Book, Driver and Hind, 1988). In New Zealand LISP generated a primary project. The perspective of that project, based on the premise that children

"do things, ask questions of themselves and others and seek to make sense of their world", was that

teaching science in the primary school should help children to achieve more meaningful (1) interaction with their world.

Meaningfulness has two aspects, viz, being able to do things, and being able to make sense of the world. We would argue that the development of both aspects should be possible at the primary level.

(1) Meaningful interaction involves process and content. By adoption of the concept of meaningfulness as a guiding principle, arguments about how much emphasis should be placed on one or the other may become unnecessary. (Symington, Osborne, Freyberg and White, 1982, p3)

The work of Osborne and his colleagues led them to adopt a generative model of learning which sought to combine constructivist views of concept learning with information - processing perspectives. In that view sensory input and memory lead to the creation of tentative meanings which are tested against existing ideas in the long term memory through the learner's processing strategies (Harlen and Osborne, 1985). Harlen has shared these ideas with primary teachers, providing an account of the role of process skills in the development of ideas in particular (1985a, chapter 3). This relation between the learning of ideas and skills was reflected in the interim report of the National Curriculum Science Working Group (DES, 1988, p18) where skills were noted as involved in the linking of experiences to existing ideas.

3.9 Views on the Learning and Teaching of Processes

Despite the emphasis on process in primary science most of the

psychological sources cited are concerned with conceptual learning. Limited reference is made to research on how skills are learnt and attitudes are formed.

The work of Gagné has had some general influence as a psychological source in science education, as well as its specific role in the identification of process hierarchies in SAPA (Gagné et al, 1967). The principle of breaking complex learning down into components has been adopted more often than the detailed application of the types of learning in Gagné's hierarchy.

Skills have been analysed to identify sub-skills or levels of performance for assessment purposes (notably in the APU surveys). Criteria for three levels of development were defined for skills, attitudes and concepts in the Progress in Learning Science Project (Match and Mismatch, 1977). Published schemes have identified steps in the development of skills to guide teachers (for instance, Presst, 1988a). Most recently the analysis of skills in terms of lines of development featured in the drafting of proposals for programmes of work and attainment levels for the National Curriculum (DES, 1988a). Those proposals noted that progress along lines of development will depend on the range of experiences in which skills are used.

Underlying much of the literature in primary science has been an implicit view of the need for skills to be actively used, and the

importance of practice and application.

we made a case for children to carry out activities, during which they became familiar with, and practice, the various aspects of process. This is to help them think scientifically when faced with a problem.

(Gilbert and Matthews, 1981-1984, p14)

The need for a critical analysis of how skills are learnt, and of the extent to which they are transferred, has become more acute as a generalised model of problem-solving has been attached to science learning. The psychological basis for asserting that children will develop general problem-solving abilities from limited experience in science or technology is uncertain, to say the least. Advances in training for problem-solving have led psychologists to be more optimistic that thinking can be taught within specific contexts. In a discussion of the evidence relating to the teaching of specific knowledge and general skills Mayer (1983) concluded that

successful courses in problem solving are courses that emphasise specific language and strategies applicable within a specific domain. (p350)

In the light of their review of sixty years of problem-solving in science teaching Champagne and Klopfer (1981) pointed to the need for a clear definition of what problem-solving ability is and for clarification of what children should be expected to attain.

The learning of attitudes is often stressed in primary science and specific attitudes which encourage or facilitate scientific activity identified. For instance many lists (eg Harlen, 1985a;

DES, 1988a) feature curiosity, respect for evidence, perseverance, critical reflection, and co-operation, which were all relevant to the pupils' work in this study. The importance of attitudes and the role of the teacher in their development is noted in many publications on primary science or technology. Other influences may be mentioned, but reference to evidence on how attitudes are learnt is rare and often tentative. Gilbert (1987a), noting that there is not one easy answer as to how attitudes might be influenced, added that

(attitudes) may possibly be influenced by, amongst other things, peer and teacher example, reasoning and discussion and, probably most important, a sense of personal achievement (p8).

Harlen (1985a, chs. 2 and 7) provided detailed analysis of attitudes and skills, and of the teacher's role in their learning. She noted the importance in teaching attitudes of showing an example, providing opportunities for the attitudes to be expressed in behaviour, and creating a classroom climate which gives approval to that. She summarised a teacher's role in skill development as the provision of materials, time, and the appropriate environment; the design of suitable tasks; encouraging and participating in discussions; and teaching necessary techniques and conventions.

Research into the effects of different teaching approaches on outcomes has not been reviewed here as the focus of the study was on the teacher's thinking, and his practice was related to that rather than to measures of pupils' learning. Underlying the

practice of primary science are views of what is to be learnt and how this occurs. Tensions and changes in these views have been explored in this review. Harlen and Osborne (1983; 1985, p133) argued that a rationale for primary science should in fact start from a vision of the way in which we want children to learn and the kind of learning we wish to promote, rather than from some general "aims of primary science". They argued that such a rationale could provide a basis for decisions about a teacher's role, organisation of a class, content and activities.

Their own generative model of learning was located within a more general 'model of models' (sic) which represented the essential features of a model for learning and teaching. Figure 3.1 shows the components of that general model, in which the double arrows indicate that linked features should be consistent in whatever particular vision of learning underpins the teaching.

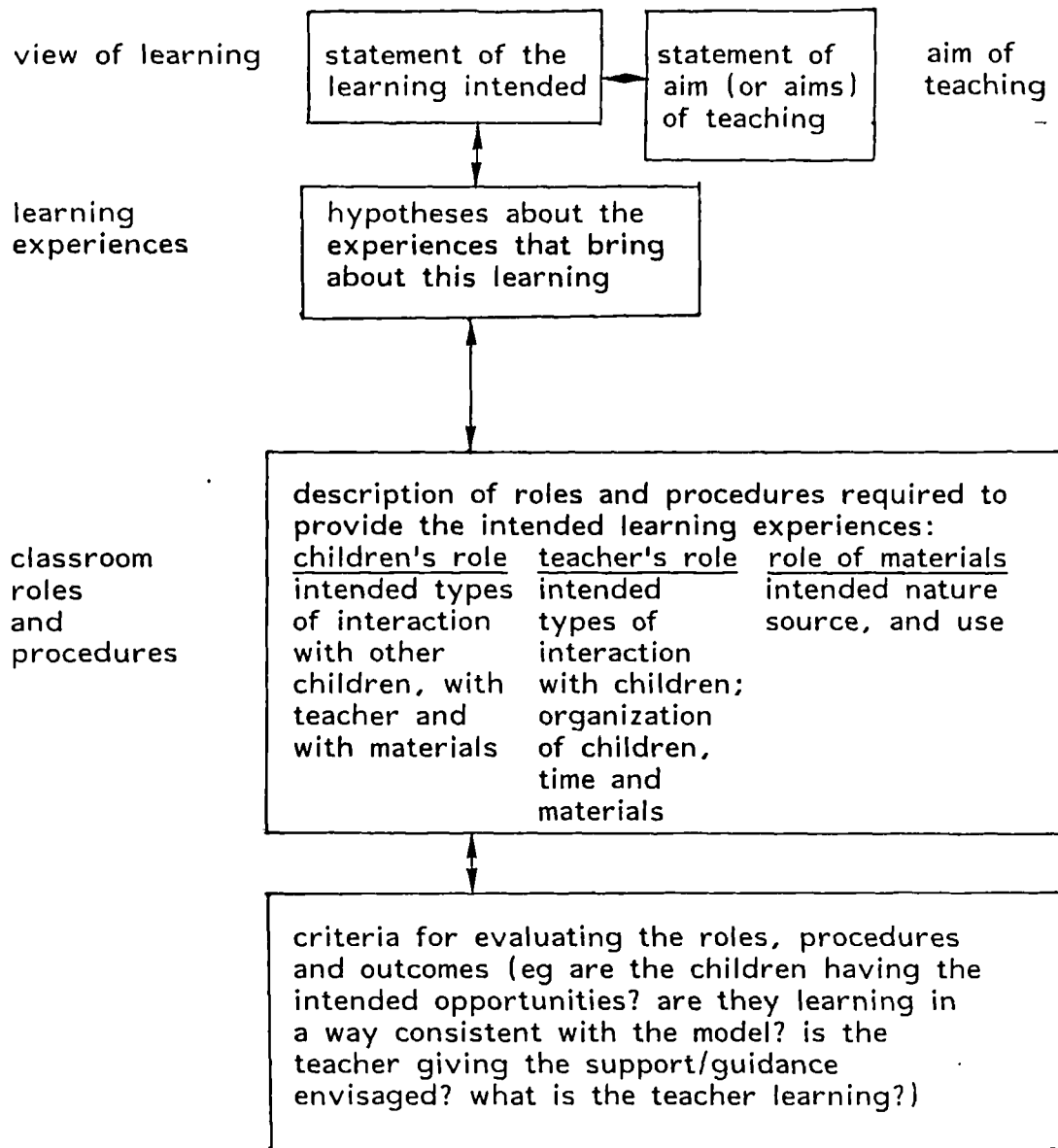

Figure 3.1 Features of a model of learning for primary science
(from Harlen and Osborne, 1983, figure 1)

3.10 Organisation of the Review of Literature on Teachers' Thinking

The growth of research in the field of teachers' thinking has created a substantial body of literature relevant to the present case. However it has been accompanied by a proliferation of terminology, methodology and conceptual frameworks. This diversity has prompted calls for consolidation by the research community (Calderhead, 1987b; Clark, 1986, Verloop, 1987). To locate the present study in relation to the literature it is necessary to provide an introductory overview conceptualising the field. This will be followed by brief reference to the arguments for situating a study of thinking in its particular context. Then the literature will be reviewed in relation to three aspects of thinking referred to as teachers' theories; planning (or preactive and postactive thinking); and interactive thinking (thinking in lessons). Finally the case for a study which integrates those aspects, and classroom action, will be linked to models of teachers' thinking and practice.

3.11 Why Study Teachers' Thinking?

Historically the study of teachers thinking can be seen as growing in the 1970's as a response to the limitations of a research approach which emphasised teacher behaviours, as Clark and Peterson (1983) and Calderhead (1987a) have described. Growing interest in studying teachers thoughts to inform our

understanding of classrooms was accompanied by concern over their role in mediating curriculum development (eg Olson, 1980). The shift to a view of teachers as more active agents and reflective professionals supported this. Descriptions of life in classrooms (Jackson, 1968), and the growth of qualitative research involving teachers, have pointed toward the goal of "portraying and understanding good teaching in all its irreducible complexity and difficulty" (Clark, 1986, p14). In that critical review of a decade of research Clark also notes its failure to address important problems in education, and the content and substance of teaching. Recently researchers have been motivated by the need to attend to subject knowledge in studies of novice and experienced teachers to understand how they build and use their professional knowledge in practice, (Berliner, 1987; Shulman, 1986). There now exists a diversity of motives for studies in this field to match the profusion of approaches and conceptual frameworks. At the most general level the goal may be

a portrayal of teaching for use by educational theorists, researchers, policy makers, curriculum designers, teacher educators, school administrators, and by teachers themselves (Clark and Peterson, 1983, p1).

More limited objectives are appropriate for individual studies, but they need to be seen in the wider context if they are not to increase the fragmentation of the field. The present case study was prompted by a concern to explicate relationships between thinking and action in the substantive area of primary science, through a research approach consistent with a view of teachers as thoughtful professionals. It also sought to provide a portrayal

with value for both teachers and researchers. Specifically it aimed to analyse the elements of thinking and integrate them in a coherent account which practitioners could relate to their own situations, and researchers to the wider field of teacher thinking. Halkes and Olson (1984) have suggested that research into teacher thinking can make a contribution to persisting problems in education in three areas:

first, to an understanding of what teachers see as significant in their work, with implications for in-service strategies; second, in showing better ways of communication with teachers who become partners in action-research or teacher education; third, by informing curriculum planners about the interaction between given plans and what teachers think about what they do. (p6)

The present case study has implications for primary science, in-service education and collaborative research on teachers' thinking that are summarised in Chapter 14.

3.12 Conceptualising the Field

The way in which the research field is conceptualised will determine the contribution it can make to the understanding of teaching and to practice. The purposes of any study will on the other hand influence the choice of a conceptual model. It is part of the argument of this thesis that a study of thinking and action should aim for an integrated account, but one which identifies the elements and their relationships. This would clearly be easier were there integration and consensus in the literature. However in the light of the diversity noted above, and the methodological arguments in Chapter 2, it would have been

inappropriate and premature to impose any comprehensive model at the outset. It was more realistic to begin from an examination of frameworks which might serve as working models for structuring the field and approaching this study. The frameworks available reflected their conceptual underpinnings more or less explicitly.

At the time of this study there was a move from the adoption of models from psychology which likened teachers to decision-makers, or limited information-processors, toward a view of the teacher as a reflective professional making sense of the world and testing theories in action. Shavelson and Stern (1981) provided an overview of the research on teachers' judgements, decisions and behaviour that had a psychological basis in the information-processing of teachers and the limits to that. Information-processing and decision-making have been popular models, tending to foster different types of research, as pointed out by Clark (1980). Other, more subjective, models have arisen as the major alternative in recent years and they are associated with different approaches and interpretations, for example of routines and dilemmas as discussed by Halkes (1986). In essence subjectivist models see such features as reflecting the complexity of teaching and interpret them in terms of the personal perspectives of teachers, often seeking to stay close to their meanings rather than reduce them to the categories imposed by the researcher.

The present case study is in the subjectivist tradition but does

not reject insights gained from other approaches. For example, the thinking during lessons has been informed by studies based on a view of teachers as decision-makers, and the links between thoughts during planning and teaching have been illuminated by information-processing models. However a teacher's actions and associated thoughts need to be seen as part of a personal performance in a particular context. The study of decisions in a lesson, and of teachers plans, needs to take account of the frame of reference of the individual teacher.

Apparently unreasonable behaviour, decisions and inexplicable thoughts may make sense when interpreted in the light of teachers' beliefs and aims, as Morine-Dersheimer (1984) found from re-analysis of data on four teachers. The plans of teachers cannot be isolated from their context or their other concerns and their values as Aikenhead (1984) demonstrated in a study of science teachers.

Decision-making may be recognised as an artful, skilled process involving values as Hargreaves (1979) described it. The underlying conception in most studies has been of the teacher as

a rational decision-maker, constantly assessing situations and making or deferring decisions on the evidence. It has directed research to the identification of the antecedents of decisions, the alternatives and the reasons teachers give for their decisions. Information-processing models have focussed less on the decisions teachers must make and more on the ways they cope with a complex environment and flow of information. They reflect a view of human information-processing and problem-solving based on analogies with limited capacity central processors in computing. There is apparent potential in such a view for modelling the ways that teachers cope with complex situations, but it should be seen as simply another metaphor for reducing the complexity of thinking. It is not a substitute for understanding the subjective experience and practice of teachers. Internal critics have also argued that the emphasis on processing in cognitive psychology has been narrowing (Claxton, 1980). Claxton noted the tacit, unobservable nature of much cognition and recommended a shift to a more active image of man-as-scientist trying out theories as described by Kelly (1955). The subjective theories in many studies of teachers' thinking draw upon Kelly's model and methods. More generally they are concerned to reflect the personal, action-oriented and dynamic nature of professional thinking. In particular they have been associated with the beliefs and theories held by teachers. There are dangers in identifying scientific theories with the personal knowledge of teachers, as Bromme (1984) has argued. For example the systematic testing of scientific hypotheses may bear only a

limited resemblance to the actual practice of professionals. A view of the action and thinking of professionals that avoids such over-identification, yet has many similarities with a Kellyian perspective, has been developed by Schon (1983;1987).

Schon's model of reflection-in-action is one in which professionals' thinking and doing are related and the practitioner can bring his knowledge to bear in new, unique, situations. It recognises that much knowing is tacit and embedded in the actions, but does not reduce that to automatic unthoughtful performance. Rather it provides a picture wherein reflection can be related to action at a number of levels. Knowing-in-action refers to the sort of knowhow revealed in the skilled actions of professionals, which they may not be able to make verbally explicit; the teacher in the present study had spoken of his own practice and that of other teachers as "just intelligent teaching". Schon refers to the process of reflection on that action, either in passing or later, in terms of reflection-in-action. This draws upon a professional's existing repertoire of exemplars, ideas, images and understandings and actions which can be tested against the situation. Both ends and means are reviewed in this process and the repertoire may be enriched. The picture and concepts developed by Schon promised a realistic yet rigorous model with which to underpin the analysis of thoughtful practice in the present case. Schon's model and the terminology were developed from work with a number of professions; although his accounts of reflective practice may

transfer to some aspects of the classroom life it may not match what is found empirically. Rather than adopting his model uncritically it is more appropriate to follow Schon's approach to uncovering the structure of professional thinking; ie, through the examination of the actual practice of experienced professionals as they reflect-in-action. This is what the present case study set out to do with one teacher.

3.13 A Descriptive Framework for Defining the Field

In their review Clark and Peterson devised the model in figure 3.2 as a device to make sense of the field (1981, fig 1). They claimed no empirical validity for their representation but provided it as an advance organiser in approaching the literature. It is used in this review for that purpose and was adopted initially in the study as framework to guide the collection and initial analysis. Clark and Peterson's heading of constraints and opportunities is extended in this review and in the study to a wider view of the context in the term situation. In the domain of teachers' thought processes the figure identifies three aspects of thinking: theories; planning (incorporating preactive thinking before lessons and postactive thinking after lessons); and thinking during lessons (often referred to as interactive thinking). These are reviewed in turn in this chapter, and related to one another and to classroom actions. In Chapter 4 the development of a working model from the interplay between the data and the literature is described.

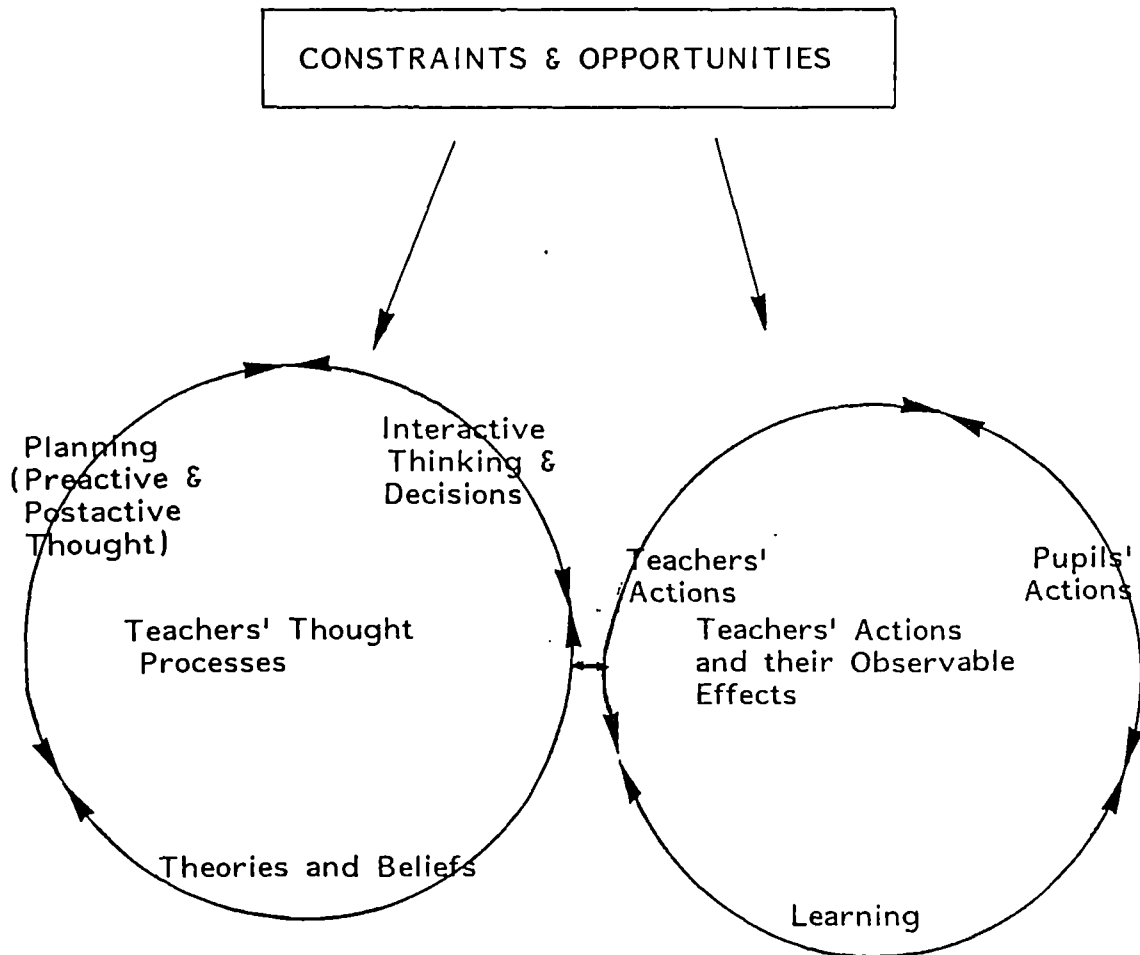

Figure 3.2 Framework for reviewing the field of teachers' thinking (Clark and Peterson, 1983)

Underpinning that was a conceptualisation of practice consistent with the view provided by Schon, and a concern to produce an integrated account of thinking and action which was close to the case.

3.14 Influences of the Immediate Setting and the Broader Context on Teachers' Thinking

There are particular reasons for including an analysis of the situation in any study of teachers' thinking. First, thinking occurs in relation to specific situations, and is oriented toward real, recalled or imagined action. Second, it is influenced by the setting and the broader context. Third, it is personal and so partakes of the individual teacher's experience.

The immediate setting of the classroom is the most obvious feature which may influence a teachers' thought and behaviour. Constraints and opportunities can be identified, for instance the space and resources available. Pressures of time and pupil numbers are commonly felt. Such factors do not operate independently and ecological studies which describe the classroom setting as a whole rather in terms of discrete elements may be appropriate, as argued by Doyle (1979). Doyle's research has emphasised the inherent complexity of classrooms and in particular the demands of management which may constrain the academic intentions. Carter and Doyle (1987) suggest that the difficulties encountered in introducing new and challenging work

are likely to lead to the modification of tasks to reduce the challenge and ease management. This may be particularly true in active science lessons when the management of a flow of action dominates the teacher's thoughts, as illustrated in some case studies cited by Smith and Sendelbach (1982). In the present case the teacher sought to make pupils accept more responsibility for their investigations, and pursue their own ideas in lessons that placed new demands on them and him. The influence of management concerns and pupil responses on his thinking needs to be analysed. Doyle and others (eg Winne and Marx, 1982) have noted the role of pupils as active agents in the realisation of the lesson, and as mediators of the tasks set. This highlights the importance of attending to the interaction between learners and teacher, and the situation within which this occurs.

Features common to primary and elementary classrooms have been noted, but the variations between situations also need attention. Teachers' thinking and practice may be quite situation specific. For instance studies which identify the role of planning in transforming published curriculum materials, like that of Smith and Sendelbach, were conducted in a situation where the curriculum is based on such material. In the present study the teacher used published resources in a very different fashion and had considerable autonomy over curriculum decisions and the conduct of his classroom. Variations between situations need to be considered in relating studies and specific features identified in each case. This does not restrict the analysis to

particulars of the classroom but indicates that the wider educational context also needs to be defined. Although it may be difficult to relate the thoughts and classroom behaviour of teachers to prevailing ideologies and outside influences, as noted by Calderhead (1984), some studies have traced links. In a series of studies on decision-making Schmidt and colleagues included external influences, such as local directives, along with internal ones, such as the teacher's subject matter priorities, and detected different patterns of content decision-making (Schmidt et al, 1987). A study of sixty elementary teachers by Bussis, Chittenden and Amarel (1976) explored the thinking and practice of teachers in relation to their ideology of open education, and included their perceptions of outside support. A number of influences traced in the present study are related to the teacher's theories and practice, his previous experience and his career concerns. The case for including those wider features of the situation in a study of teaching was made by Goodson (1983) in arguing for the rehabilitation of life-history. Goodson noted that a teacher's previous career and life experiences will shape his views and actions, and that his life outside school will impact on his work. The origins of teachers' knowledge, and links between the various psychological and social contexts of their work, were examined in a study reported by Zeichner, Tabachnik, and Densmore (1987). Zeichner et al traced the development of elementary student teachers and emphasised the interactions of individual and institutional factors. They identified their subjects'

perspectives on knowledge and the curriculum, teachers and pupils, and turned to the concept of dilemmas to interpret those perspectives. That concept was derived from the work of Berlak and Berlak (1981), which explored some apparent contradictions in the practice of primary education.

The term dilemmas has been used in a number of ways in the literature. It may be used simply to convey that conflicts are inherent in classroom practice, or to relate them to the values and theories of teachers. Dilemmas can also refer to contradictions between the particular situation and the theories that teachers hold, such as those faced by Zeichner's subjects.

3.15 Teachers' Theories

It has already been argued that it is necessary to include analysis of teachers' beliefs and theories in order to make sense of their thinking and their actions. Munby (1982) suggested that neglect of this had flawed many earlier studies, particularly where it had been assumed that teachers and researchers shared the same perceptions. Clark and Peterson (1983) saw the purpose of research into teachers' theories as being to make explicit their frames of reference. The implicit nature of such theories makes them challenging to research. However they are central to a study which seeks to unpack an individual teacher's thinking and practice in order to produce an integrated account. They incorporate cognitive and affective

dimensions of professional knowledge which is personally held and related to action.

3.15.1 Terminology and conceptualisation of studies of teachers' theories

The methodology, concepts and terminology in studies of teachers' theories vary greatly, but some common ground can be detected. This is illustrated by the use of the term personal in such studies, which has been reviewed by Clandinin and Connelly (1986). In their review of twelve studies they conclude that they have much in common in their concern to understand the content of teachers' thought, although some are more focussed on the form in which it is held. Clandinin and Connelly suggest that despite using different methodologies and terms, such as "principles", "constructs", "criteria" and "conceptions", many studies seem to give similar answers to the question of what is in the teacher's mind. Others however produce "longer, more complex, less precise, and more context dependent accounts" which "yield understandings different in kind" (1986, p27). Clandinin and Connelly argue that the relationship of theories to previous experience and to action is assumed rather than unpacked in most studies. They also note the need to incorporate an affective dimension, suggesting that most studies conceive of teacher thought in cognitive terms. Their interpretations have been questioned by some of the authors of those studies in the ensuing debate (eg Marland, 1987). In their own research the notion of

personal combined action, experiences and feeling in an integrated picture of personally held knowledge (Connelly and Clandinin, 1984, p136).

One productive approach to the theories of teachers is based on a constructivist psychology. It often adopts the position and methods of Kelly's (1955) personal construct theory, identifying teachers' constructs with an emphasis on their views of knowledge. Olson (1982b), in an issue of Interchange devoted to constructivism and education, welcomed the holistic, humanistic concern of the approach and the opportunity it offered for understanding teachers' actions and changing practice. Such concerns are by no means restricted to constructivism. Studies in that tradition have shared a good deal of common ground with ethnomethodology, symbolic interactionism and phenomenology, as pointed out in the same issue by Pope (1982,p3). Drawing upon a Kellyian perspective, Pope argued that theories of knowledge will be integrated into the repertoire of constructs which a teacher holds, and analysed their implicit theories (Pope and Scott, 1984). The notion of a repertoire is found in other studies using different perspectives, and was developed in this case following the teacher's use of the term. Metaphors used by teachers have been seen as a promising way of using teachers' language to understand their thinking by Munby (1986), who has shifted to this approach from his earlier use of the techniques of construct theory (Munby, 1983).

Other studies have referred to teacher's implicit or intuitive theories. Several by Pope and colleagues, and by Smith and Anderson (eg,1983), are concerned with science education and also indicate how the construction of the learners' ideas may be studied in relation to those of the teacher. The need to develop such links has been pointed out in recent commentaries on the direction of research in teacher thinking (eg Calderhead, 1987b).

Studies with different orientations have used terms such as personal principles, perspectives, criteria and practical knowledge. In some cases these reflect the integration of beliefs, understandings and views about teaching with wider values through the teachers' practice. This can be seen in three studies with different approaches. Janesick (1977) undertook a long ethnographic study of a teacher and developed an account of the teacher's perspective about his role. The perspective was defined as a reflective, socially-derived interpretation of experience which formed the basis for subsequent action. It combined beliefs, intentions and behaviour which interacted and were modified. Elbaz (1983) constructed a picture of one teacher's practical knowledge from interview data. She described practical knowledge as the integration of personal beliefs, values and all kinds of knowledge oriented to the practical situations in which the teacher operated. Halkes and Deijkers (1984) used repertory grid, stimulated recall and questionnaire to explore the personal subjective criteria teachers try to keep constant while teaching. They termed these teaching criteria,

which include personal action rules, principles, intentions, and images of teaching-learning. Each of these studies has different terms and descriptions. However each illustrates the possibility of identifying the ingredients of a teacher's personal theories and integrating them in relation to classroom action.

3.15.2 The content of teachers' theories

What are the elements of teachers' theories which research has examined? A few studies have focussed on particular features such as discipline, or how to handle aggression (Krause, 1986). Some have explored the teachers' conceptions of teaching a subject, eg reading in Duffy (1981). Their theories of teaching science have been studied in relation to the difficulties in implementing curricula (eg Olson, 1982). Subject knowledge has been studied in relation to other elements of professional knowledge in science teachers by Shulman and colleagues (eg Wilson, Shulman and Richert, 1987). Broader understanding and views of teaching and learning may encompass subject teaching or be studied in the context of an overall ideology of education, as they were in the work of Bussis, Amarel and Chittenden (1976). In that study elementary teachers' understandings of curriculum and children were analysed in relation to teaching priorities, personal values and their espoused commitment to open education. Some studies of personal knowledge include an individual's awareness of the milieu in which they operate and of themselves. Teachers' feelings and their images of teaching feature in the

work of Elbaz (1983) and that of Clandinin (1986). In the present case study there is evidence of the teacher's knowledge and beliefs concerning the substantive field of primary science as well as those about teaching, learning, children, the situation and himself. These are identified and related to one another and the action. His views of learning and images of how that should occur played a central role in the organisation of his thoughts and actions. There were tensions between elements of his theories, and in their relation to the behavioural world which led to dilemmas. His responses to those dilemmas did themselves give insights into his theories and had the potential for modifying and enriching them.

3.15.3 Dilemmas and teachers' theories

Argyris and Schon (1974) pointed out that dilemmas arising from conflicts among theories, or between theories and practice, could initiate the building of new theory. Their contrast of the theories espoused by professionals and the theories-in-use which underpin their actual practice has been a productive one for teacher research. A similar notion of the gap between intention and performance has been a source for research with, or by, teachers as discussed for instance by Ebbutt (1983) and Hopkins (1985). In the example cited by Hopkins, of teachers in the Ford Teaching Project, the gap was between the espoused theory of independent learning and the practice in primary classrooms. The discovery of discrepancies between these was frequently stressful

for the teachers concerned; this underlines the affective aspect and the difficulties in changing theories-in-use.

3.16 Teachers' Planning

Between theories and actions lie plans. That at least is the simplest way of locating planning thoughts, which may be seen as the translation of general theories and intentions into more specific plans for action. In that picture evaluation would follow and a clear distinction could be made between the preactive, interactive, and postactive phases of thinking. This linear model and separation of the phases, however, does not seem to be reflected either in practice or in the literature.

Cyclical models, such as that developed by Yinger (1977) from his study of one teacher's planning, are much closer to the reality of movement back and forth among plans, interactive thoughts and reflection after the action. Experienced teachers are rarely found to use an approach to planning that follows the linear objectives model that may have been prescribed in their training, as Clark has noted in a number of reviews over the years (Clark, 1983; Clark and Peterson, 1983; Clark and Yinger, 1980; 1987).

Clark and Peterson (1983) also noted that researchers had not retained the tidy distinction between preactive and postactive thinking. However the studies they reviewed emphasised the preactive phase, and in an earlier review Shavelson and Stern (1981) had found little evidence of studies on the phase of

teaching when teachers assess their plans and accomplishments and so revise them for the future. More recently Lowyck's (1986) study of twelve elementary teachers' reflections after lessons confirms the lack of a clear separation between preactive and postactive thoughts. The findings support the case for viewing them as related and indicate the need to trace the relationships in the present study. It should not be assumed however that preactive and postactive thinking have identical content and structure.

Planning is important to teachers but not always visible, and written plans probably play a small part in the planning that experienced teachers do for their own purposes. However researchers' attempts to make explicit the mental planning of teachers may not reveal their normal practice. Think-aloud methods can provide insights for the teacher as well as the researcher but are inappropriate in naturalistic studies such as the present one. Even if teachers are making written plans they will not match the detail of their mental plan for a lesson, as Morine-Dersheimer (1979) found. In any case those methods focus on lesson planning which is only one aspect, and has not been found to be the main concern of experienced teachers; for example teachers identified longer term plans for units, weeks or days as important in a study by Clark and Yinger (1979). It was therefore necessary to seek a variety of evidence of planning as it occurred naturally in the present case. Where written plans existed they were collected, but much of the thinking at the

preactive and postactive phases occurred incidentally and unsystematically. It needed to be recorded and compared to uncover the teacher's planning in all its variety. According to Clark and Yinger (1987) few studies have attempted this, and educators could benefit from more which describe the full range of the kinds of planning that teachers do over the year and the relationships between those. The present study analysed the following range of preactive and postactive thinking: the teacher's long-term goals and strategies; his selection of activities and changing plans for their use in lessons over a term; reflections and remarks before and after lessons; thoughts out of school time; the consultation of publications and trial of resources; the teacher's comments on his own planning approach; and his assessments of progress by pupils and of his own teaching.

The picture of planning suggested by the review is of a complex, layered process with dynamic relationships among layers. Yinger (1977) identified five layers or kinds of planning by an elementary teacher over five months, Clark and Yinger (1979) detected eight kinds from a survey of seventy eight teachers, and Clark and Peterson summarising those findings noted that most designated a unit of time (1983). The yearly planning can be viewed as the setting up of an academic and social frame within which later plans and teaching occur; a number of studies have

confirmed its continuing influence over the year (Clark and Yinger, 1987). This description matches the experience and practice of primary teachers faced with a new class each year, and any study of later planning should ideally be situated within that framework. In the present case this was possible. From the start of the year data were also collected on the changing plans for the term which was to be the focus of the study. The elements and structure of that termly plan could then be related to the lower layers of planning for units, weeks, days and lessons. The literature suggests that planning is a nested process in which unit, weekly and daily planning are stressed, but it cannot be assumed this will be true for all contexts and teachers. It is necessary to derive the elements from the data and set them against the models and terms suggested by the literature. Categories identified in teacher planning do vary between studies, possibly reflecting differences in methodology as well as the specificity of much teacher planning, as suggested by Tillema (1984).

The relationships within planning suggest a model which is dynamic and has features similar to the reflection-in-action of professionals described by Schon. It involves simultaneous consideration of ends and means, testing out possibilities in what Schon (1987) has termed virtual worlds. The similarity is reinforced when planning is related to a teacher's theories and knowledge. Schon's notion of a repertoire which is drawn upon in bringing past experience to bear on new situations can be tested

in the analysis of planning by teachers. Other researchers and reviewers have viewed planning similarly as a reflective, problem-solving process in which experienced teachers use knowledge in expert ways (eg Calderhead, 1984; Berliner, 1987); some make direct reference to Schon and the term repertoire (Clark and Yinger, 1987). The literature suggests use of that repertoire during planning may involve reference to exemplars, cases and activities structured through experience.

3.17 Interactive Thinking. Teachers' Thinking and Decisions During Lessons

The thinking that teachers do during lessons is often termed interactive. Sometimes it is identified with the making of decisions in the course of a lesson, referred to as interactive or in-flight decision making. In more subjective theories thoughts may be viewed as implicit in the skilled action of experienced teachers, as in Olson's (1984) argument that the intelligence is in the practice. A teacher may find time even in a busy lesson to pause and reflect on the action or on his theories and plans, but the literature is divided over how far this occurs and over the number of decisions teachers make in lessons. There have been many studies concerned to identify the frequency, type or antecedents of decisions (eg Mackay and Marland, 1978; Marland, 1977; Sutcliffe and Whitfield, 1979). Decision-making has been postulated as a basic teaching skill (Shavelson, 1973). However Clark and Peterson in reviewing this

work noted that models of interactive decision-making were probably premature and misleading (1983). Models and accounts sought to explain how teachers cope with the complexity and busyness of classroom life, respond to cues from pupils, and make use of teachable moments. Metaphors of balancing, judging, or decision-making may impose some order on that complexity but at the risk of isolating interactive thinking from the complex reality and from other aspects of thinking by the individual teacher. Carter and Doyle (1987) have emphasised that information about teachers' knowledge structures and comprehension processes is essential to an understanding of their plans and decisions. The present study analysed classroom thinking in relation to the teacher's plans and theories.

The link between planning and action has been traced in a number of studies using different methodologies in various contexts. In reviewing them Clark concluded that plans do affect classroom processes and learning opportunities (1983). However he also stressed that once a lesson begins plans move into the background and a different sort of thinking predominates. Studies in the information-processing tradition have suggested that the plans provide a frame or image of a lesson within which fine tuning occurs during the lesson (Joyce, 1980; Morine-Dershimer, 1979). The extent of the discrepancy between the image and the reality may determine the sort of thinking a teacher does, as Morine-Dershimer (1979) suggested in her analysis of three case studies of reading lessons. In related studies, McNair (1978-9)

argued for a shift from a decision-making focus to a realisation that in lessons teachers are concentrating on the fine tuning of the activity flow. Joyce (1980) concluded that future research should examine interactive thinking in the context of long-term decisions, the flow of activities and the selection of materials.

3.17.1 Dilemmas and thinking in lessons

Teachers interpret classroom events through a personal perspective and draw upon tacit knowledge and values to reach a decision. Analysis of their accounts may give access to such perspectives and knowledge, particularly if it is possible to explicate the associated dilemmas. Subjectivist studies recognise that in thinking about their particular dilemmas teachers do not simply have to choose between mutually exclusive alternatives but face conflicts over multiple goals and means. The management of such conflicts in unique situations by individual teachers has been explored by Lampert (1984, 1985, 1986). Working with elementary teachers she has drawn upon group discussions, individual interviews, classroom observations, journals and her own teaching to develop a view of teacher thinking that is broader than decision-making. In her picture the teacher is continually redefining ends as well as confronting choices about means, and dilemmas are endemic and useful features of exploratory teaching. This relation between action and thinking is reminiscent of the notion of reflective practice, and will be explored in the analysis of dilemmas in the present study.

3.18 Toward an Integrated Account of Thinking and Practice

This review of the literature relating to the different aspects of teacher thinking has developed the argument for an integrated account within which the elements and their relationships are explored. Some case studies have attempted this and they illustrate the potential and problems. Elbaz (1983) elaborated a general structure of personal practical knowledge from her study of one teacher. The study was based on interviews, and a wider range of data, including observations, would have been appropriate. It argues for reflexivity and an active involvement of the teacher, but offers limited information on her background or the researcher's. Despite these reservations, and others about its rigour (Barnes, 1983), it is an important example of the possibility of a holistic portrayal which generated a model of thinking that has stimulated research. The personal, decision-oriented nature of a teacher's knowledge links thinking and action in her account. She developed a model in which practical knowledge is depicted at three levels: at the lowest level are rules of practice which refer to means for use in particular situations; at an intermediate level are practical principles which are more inclusive and less explicit than rules, and imply the teacher's purposes; at the highest, most inclusive level, are images. These images are broad notions drawing on a teacher's feelings, values, needs and beliefs and representing a

personal vision of how teaching should be. In this structure each level mediates action and thought in different ways, and the relationships among levels can be examined. The notion of image was adopted in a study of two primary teachers by Clandinin (1986) using participant observation as well as interviews. Although it has possibilities for working closely with teachers, it unfortunately adds another meaning to the term image, which was already used in research on teacher thinking. The concept of a lesson image has been used in studies based on information-processing models to relate interactive thinking to previous planning; for example the consequences of different degrees of discrepancy between such an image and the classroom reality were analysed by Morine-Dersheimer (1979). In a later study (Morine-Dersheimer, 1984) the term referred to the images in the teachers' language which were the basis of analysis.

3.19 Summary of Implications of the Literature Review

This review of the literature has pointed to the need for studies tracing the dynamic relationships among the aspects of thinking (discussed under the headings of theories, planning, and interactive thinking) and their integration with classroom action. It has revealed a lack of attention to curriculum context and subject knowledge in most studies, subsequently termed "the missing paradigm problem" by Shulman (1986,p6). Studies by Shulman and colleagues, and by Berliner (1987), have traced how subject knowledge is used in relation to other aspects

of professional knowledge by secondary teachers of science and other subjects. There is a need for research with primary teachers to unpack the relationships and to explore how their knowledge is built and used.

The review of primary science literature indicated that arguments about the importance of subject knowledge were not based on firm research evidence. It also identified the centrality of a view of learning in the practice and theory of primary science. Issues concerning the analysis and teaching of concepts and processes, problem-solving and technology were examined in relation to the rapid developments in primary science over the period of this study. Those developments accelerated as the study was being completed. With the advent of the National Curriculum these issues are pressing concerns for primary teachers and research which examines how teachers think and act as they face the challenges of primary science is needed. The present study was designed to do this before the National Curriculum was envisaged but it was informed by the accumulating literature in primary science and in the more general field of teachers' thinking.

In summary the review of literature on teachers' thinking strengthened the argument for undertaking a case study to provide an integrated account of the teacher's thinking; underlined the importance of examining this in relation to a specific curriculum area and to classroom practice; pointed to the importance of

attending to the broader context as well as the specific situation; provided a framework within which data on these elements can be collected, analysed and related; indicated a general picture of the reflective practice of professionals which can be tested against this particular case without premature reduction or distortion of the study; and examined a number of concepts and terms with potential for the analysis. In Chapter 4 the models and concepts are related to the case to develop the working model and terms used in the present study.

CHAPTER 4 THE WORKING MODEL USED AS A FRAMEWORK FOR THE CASE STUDY

4.1 Introduction: Origins of the Model

In this chapter the framework which guided the collection and analysis of the data is described. That framework is represented as a working model and some details of the components and relationships in that model are introduced. This provides an advance organiser for the account of the case study in Chapters 6 to 12. The model and the literature are revisited and re-examined in Chapter 13.

The origins of the working model in the literature review were identified in Chapter 3. The model proposed by Clark and Peterson (1983) to conceptualise the literature provided a basis for the development of an appropriate framework for the present case (figure 3.2). The study sought to provide an integrated account which analysed the different aspects of a teacher's thinking and related them to one another, his classroom actions and the context of the particular case. With the minor modification shown in figure 4.1, Clark and Peterson's model was adopted as a starting point.

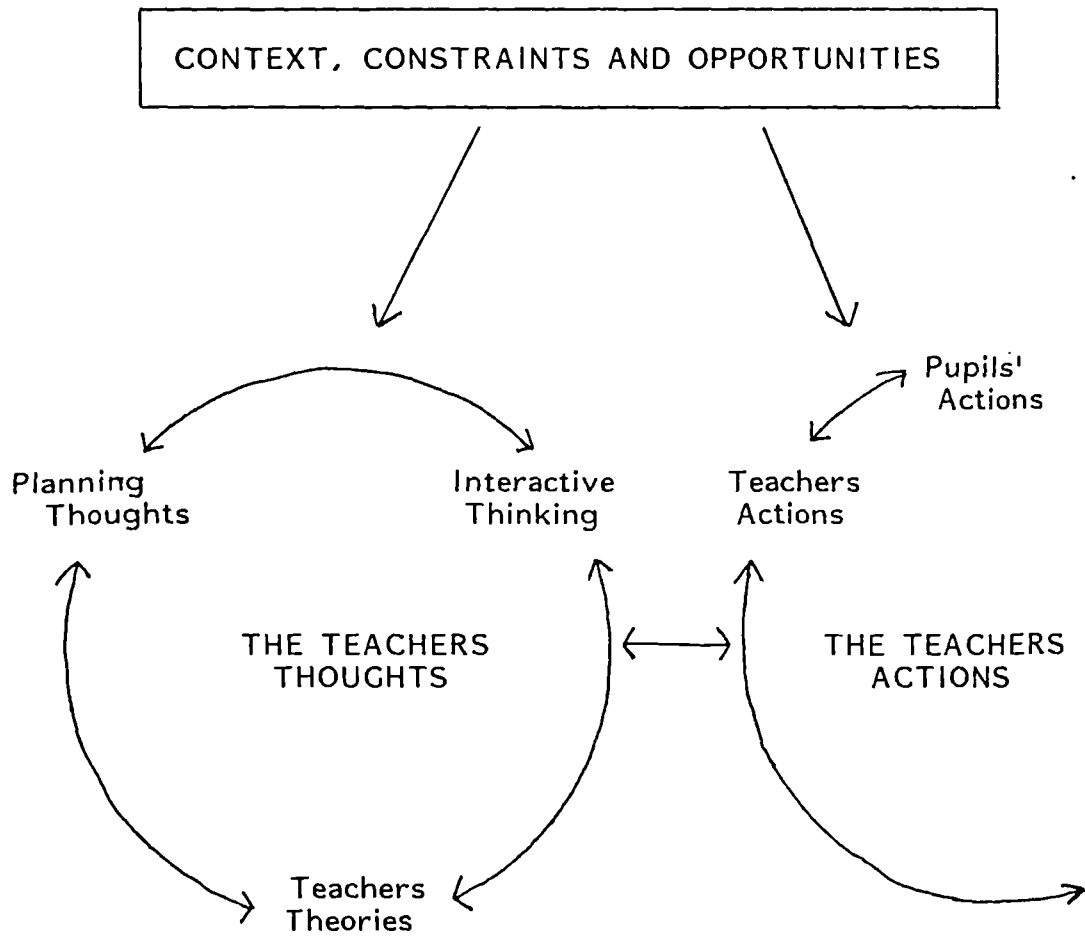

Figure 4.1 Starting point for the working model (after Clark and Peterson, 1983)

4.2 Generation of the Framework in this Case

The representation in figure 4.1 served as an aide-memoire at the stage of reviewing the scope of data to be collected and the potential broad headings and relationships for analysis. It provided a very open framework which was descriptive rather than explanatory. The influence of contextual constraints and opportunities, both on teachers' thoughts and on their actions, was recognised. Links between thinking and action were suggested. Relationships were not depicted as fixed or hierarchical, and the cyclical representation offered comprehensive possibilities for relating three aspects of thinking, ie theories, planning, and interactive thoughts. Its comprehensiveness was an attraction - and potentially a danger as it indicated such a wide range of data to collect and relate. Although this was consistent with the spirit of this stage of the case study the lack of focus could have led to drift. However this was overcome by negotiating with the teacher the concerns of the action and research for the term, as noted in Chapter 1. (see Table 1.1).

Those concerns reflected a view of what was to be learnt and how this was to occur. In this case the teacher's practice was based on his aims for the learning of skills and attitudes associated with the planning and carrying out of investigations, with some incidental concept learning. He had in mind strategies and roles and activities which he saw as appropriate to foster that

CONTEXT OF TEACHER'S SELF AND SITUATION, INFLUENCES,
CONSTRAINTS AND OPPORTUNITIES

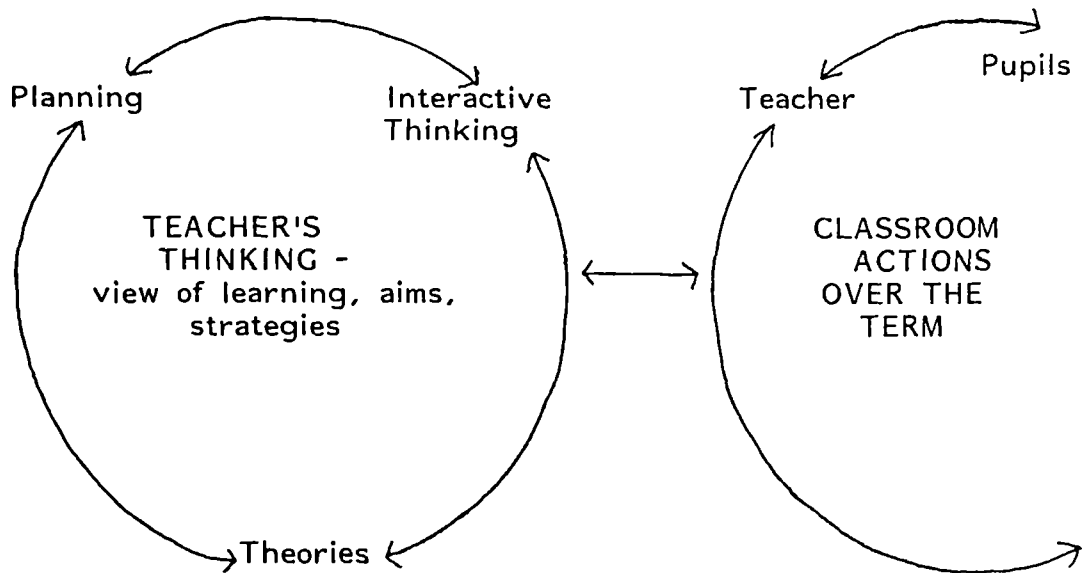

Figure 4.2 Representation of the initial framework in the study

learning.

In essence the first stages of this study were focussed by those agreed aims and strategies. They were located within the general framework adopted as shown in figure 4.2.

4.3 Use and Modification of the Framework During Fieldwork

During data collection analytical memos were made and halfway through the summer term a systematic review of the categories and structures of the model was undertaken. The framework that had guided initial collection and analysis was itself altered by the outcomes of that analysis and in turn focussed those activities in the second half of the term.

By this stage much detail of the context had been elicited from interview and observation. Further categories, concerning for example the teacher's career, the pressures of time and disruptions, the demands of a broad primary curriculum, and pupil factors, had been noted. Each aspect of thinking was revealing internal features to probe further; for instance planning thoughts showed a concern with timing and the shuffling of potential activities from a repertoire identified by the teacher. External relationships between aspects were emerging; for instance lessons imagined in planning deviated more or less from that image in their realisation, and the teacher reflected after a lesson upon the pupils' response and his own interactions in

relation to the image and reality.

The initial framework had ensured that data was collected on the agreed concerns, the action and the context, and that aspects of the teacher's thinking could be analysed and related. Despite data overload and the emergence of potential analytical categories the imposition of any fixed model to reduce data was avoided. However it became possible to make more selective observations. Amendments to the original framework were explored and tentative categories for analysis derived from inspection across data sets.

Toward the end of the period of data collection systematic building of a model to relate thinking and action in the case was begun. Early versions reflected the current immersion in fieldwork, emphasising the more immediate concerns of the teacher for example, or featuring a rather linear flow from general theories through plans and strategies to actions.

4.4 Development of the Working Model During Analysis

In preparation for detailed analysis of all data the categories were sharpened and coded. Applying these systematically led to the collapsing of some categories and to other modifications.

This process and the analytical categories are outlined in Appendices 6 and 7.

Further modifications to the model were indicated as data sets were compared and themes, concepts and dilemmas identified. Movement between the data and the model was accompanied by reading of the growing literature in the field of teachers' thinking. In this iterative procedure alterations were made in the model that were consistent with the interpretation of the case and faithful to the original intention of representing the elements and their relationship in an integrated picture. For instance the analysis of thinking revealed layers which could be depicted as nesting within one another but also showed instances of dynamic relationships between a variety of layers. Planning matched this nesting model most closely and layers therein could be equated with different time-scales. Short term plans and evaluations related to interactive thinking in many instances, but classroom actions and deferred decisions at times drew upon more distant layers. The overall goals of the teacher had taken precedence over more immediate plans for some lessons when reality diverged from image. So models restricting interactive thinking to the fine tuning of planning decisions were inadequate, although consistent with the appearance of many lessons.

After the first analysis the working model was reviewed. The position at that stage was summarised:

The Framework used to analyse the data and the Working Model underlying the case study that follows is based on the following principles and priorities:

1. It reflects the case and allows movement between data

and literature

2. It is holistic in that it seeks to provide an integrated account without ignoring the need for analysis. In that analysis key concepts, issues and dilemmas are identified.

The elements involved in this analysis are:

3.1 Three aspects of thinking; ie planning, interactive thought and teacher's theories.

3.2 Actions (interactions with individuals, groups, class; teacher activities).

3.3 Situation (pupils, classroom and school; teacher's career and self; influences, educational ideologies, and broader socio - historical context).

The relationships to uncover include:

4.1 internally within elements, (eg between layers of planning; between teachers professional principles and wider personal beliefs).

4.2 between elements of thinking (eg is interactive thinking merely 'fine-tuning' of planning? Do in-flight decisions have any impact on evaluations, plans or even beliefs? How do teacher's theories influence plans and interactive thinking and what causes them to be re-examined?)

4.3 between actions and thoughts - is the relationship unidirectional, reciprocal, or more complex? Can it be represented and modelled?

At this stage it is suggested that this is possible and the whole can be characterised in terms of reflective practice; relationships may be modelled as shown (in figure 4.3). The whole and the parts of this picture can be explored in the analysis to follow. Key concepts such as the 'image or frame' of a lesson formed in planning, the role of 'activities' as units of planning and the teacher's deployment of a 'repertoire' of these, and the notion of 'dilemmas' as productive for the analysis and the account will be tested.

(From memo of June 1987)

Figure 4.3 represents the working model used in the final analysis and in reporting the study. It was the basis for analysing the elements and exploring relationships between them.

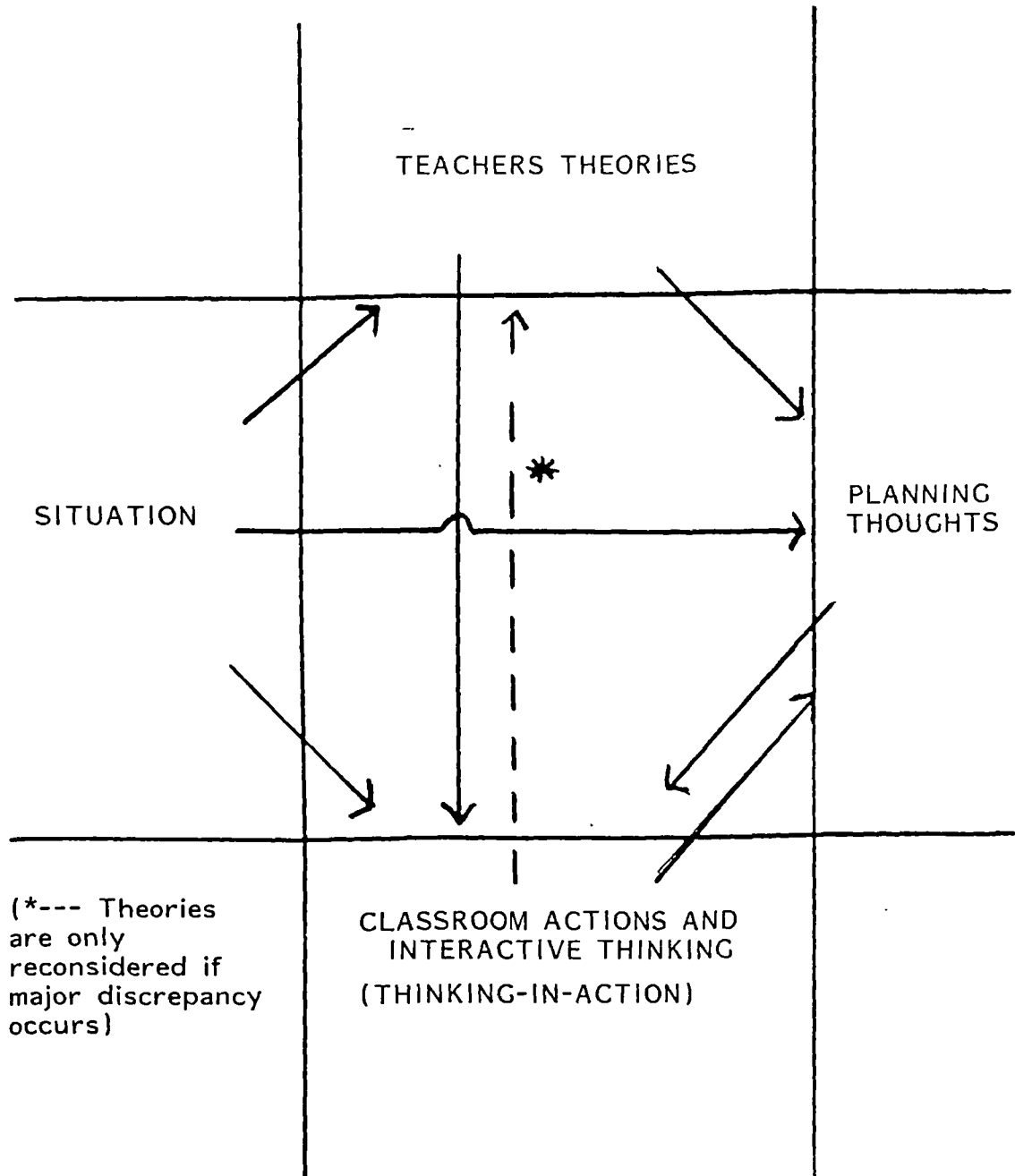

Figure 4.3 Working model used in analysis

The major headings on each side of the display were the Situation, the Teacher's Theories, Planning Thoughts, and Interactive Thinking closely linked with Classroom Actions, referred to as Thinking-in-Action. These headings were divided into the finer analytical categories shown in Appendix 7.

4.5 The Situation

This heading includes the constraints and opportunities of the original framework, the immediate classroom setting, and the broader socio-historical context. The teacher, his career, and influences upon him are incorporated here. His practice can be related to his present context and his past experiences. Details of the teacher's personal background along with his professional development are provided to situate the case in time as well as to convey a picture of the context. The incorporation of biographical material reflects in part a recognition that a practitioner's previous career and life experience shape his thinking and action, which also need to be related to contemporary educational developments. In this case the time scale is extended to future career concerns of the teacher. The analysis of the situation was structured under sub-headings of career, class teaching, opportunities and constraints, each being subdivided into finer categories for initial coding of data. In Chapter 6 features of the situation are described. Relationships between elements of the situation and with aspects of thinking are analysed. The analysis of their influence on theories,

planning and interactive thinking is pursued in the subsequent chapters.

4.6 The Teacher's Theories

This term was derived from the review of literature as the heading under which data on one broad aspect of thinking was collected, analysed and reported. The teacher's personal beliefs and values, theories and principles and knowledge concerning pupils, pedagogy and subject matter are all subsumed under this heading. There is justification for keeping them together: for example they can be seen as existing at a more general level than thinking under the other two headings; they are not mapped directly onto a particular flow of action in time; and they are personally held and integrated with deeper beliefs which may render them resistant to change. The analysis of the teacher's theories was structured under the sub-headings of views and knowledge relating to children, learning and teaching, and primary science. This is reported in Chapter 7. The relationship of theories to planning, and to thinking and actions in the classroom, is examined from Chapter 7 on. Figure 4.3 shows direct links from theories to plans, and to classroom action and thinking, and the possibility of a reciprocal relationship when major discrepancies between classroom behaviour and theory prompt a re-examination. This, and other possible links, were explored in the case. The analysis included the teacher's knowledge as well as his views.

The metaphor of a repertoire, derived from the study and supported by an examination of the literature, proved helpful in understanding how the teacher's knowledge was held and used and extended. At the most general level this metaphor represents the understandings, examples and images a practitioner can bring to bear on a new situation. They include knowledge of subject matter, teaching approaches, pupils, and general educational knowledge. The content and structure of the teacher's knowledge is examined in Chapter 7. Its relationship to planning and classroom thought and action is traced in the following chapters, and the ways in which it may be extended and restructured are examined. The analysis of planning in Chapter 8 indicates how the teacher drew upon his repertoire as he selected and shuffled potential activities (see figure 8.2).

4.7 Planning Thoughts

This heading covers the preactive and postactive thinking associated with plans and evaluations. Planning occurred at a number of layers which were nested within one another but not cut off from more distant layers. For example, lesson planning was subsumed under longer-term plans for units of several lessons, but reference was also made to overall intentions for the term. Preactive thinking involved movement back and forth in time and among layers. The analysis of planning presented in Chapter 8 led to a representation reflecting this complex and dynamic

structure (figure 8.1). It was also related to the action and thinking in real time over the term (figure 8.2).

The teacher's planning thoughts featured the selection and sequencing of activities from his repertoire. The term activity here signifies a unit in his thinking, constituted by one or more tasks with a common theme or purpose, having a discrete use as an element in planning. The references the teacher made to activities in his repertoire when he reported his planning thoughts ranged from general labels for themes (for instance, bicycles) to details of a specific investigation for pupils.

At some point in time decisions had to be made to deploy particular activities and the mental shuffling and rehearsal had to give way to real action. The study indicates major points of strategic decisions representing a change of activity or of teaching approach and seeks to unpack the thinking behind those decisions. They appeared to involve a reference up to higher levels of thinking concerning long term aims, and a review of the selection from his repertoire. Action and interactive thinking could be the stimulus for the decision and the more general thinking, particularly where there was a discrepancy between the imagined lesson and reality.

Images were formed by the teacher in his planning as he anticipated the flow of action. His images of the term, or of the next activity, or of lessons, were progressively focussed as

the action approached and possibilities had to be realised in practice. The focussing involved a number of ingredients which are analysed in the study. The metaphor of an image proved useful in that analysis. Unfortunately the term image has been used in a number of ways by researchers. In the present study the term is always qualified as an image of something, such as the term's topic or a sequence of lessons. Most often it refers to the image of a particular lesson and in this sense it proved a valuable tool for analysing and reporting the link from plans to classroom action and thought.

4.8 Thinking-in-Action

The actions and thinking during classroom lessons are analysed under this heading which conveys their close relationship but is less limiting than the terms in-flight decisions or interactive thinking. Thinking in lessons included, but was not restricted to, that concerning decision-making or interactions with pupils. For example references to the situation, plans and theories were witnessed and had to be accommodated in the working model.

The translation of the imagined lesson into reality provided a link from plans to actions. The notion that the degree of fit or discrepancy between these determined the sort of thinking-in-action by the teacher was explored. His thinking was seen to be more complex than this picture of fine tuning and decisions prompted by pupil responses. The relationships of

classroom actions and thoughts to theories and to the situation are also traced. The outcomes of this analysis of thinking-in-action and its relationships with the other elements in the model are presented chronologically from the end of Chapter 8 through to Chapter 12. The analysis is cumulated from chapter to chapter to produce an integrated picture of thinking and practice against which the underlying model of reflective practice is tested. In the light of the analysis Chapter 13 revisits that model and the framework for the case study discussed in this chapter.

In his practice the teacher integrated thought and action in a particular situation. The case study reports that and analyses the elements and relationships within the integrated picture. It also identifies tensions and conflicts which are involved, for example in managing active science lessons or when beliefs or theories are in conflict. Conflicts or discrepancies may also exist between theories, plans, and classroom realities. Tensions and conflicts may be summarised in dilemmas. The concept of dilemma was productive for the analysis and is used in reporting the study. It is suggested that reflection upon practice is prompted most powerfully by such dilemmas, and that restructuring of professional knowledge and theories occur in response to the tension experienced.

CHAPTER 5 A DESCRIPTIVE AND CHRONOLOGICAL OVERVIEW OF THE CASE

5.1 Introduction

This chapter provides a descriptive and chronological overview of the work during the school year 1983-84 which was the basis of this study. The setting and background of the teacher's ideas and plans are only briefly noted, as they are examined in detail in Chapters 6 to 8. It summarises the stages in the science work that took place over the summer term, which is described and analysed in Chapters 9 to 12.

The study followed the work of a primary teacher with his class of nine to ten year olds. He was an experienced teacher who also had responsibility for science and mathematics in the school. In the summer term 1984 the science for this class was centred on a theme of Toys, involving a lot of model making and testing. The teacher used these activities to promote more independent inquiry by his pupils and to extend their skills in planning and pursuing investigations. Incidental teaching about forces and structures was included. In his earliest plans for the term he had in fact talked of a topic on forces, but this was modified over the year. Table 5.1 summarises the teacher's action and the research activities over the first two terms of the year in preparation for the summer. Figures 5.1, 5.2 and 5.3 illustrate

TABLE 5.1 PREPARATIONS FOR THE SUMMER TERM SCIENCE ACTION AND RESEARCH

TIME	TEACHER'S ACTION	RESEARCH ACTIVITIES
Autumn 1983	Outline aims and plans for the year Consider possibilities for summer New class to settle in	Meetings and interview, contact class
Spring 1984	Review pupils' progress Adjust plans, firm up topic and identify framework of intentions	Interview, visits trial observations Discuss roles and procedures for observations and recording
11 April 12 April	Preliminary lesson introduces topic. Confirm plans for topic	Record Interview



Figure 5.1 The teacher with a group of pupils



Figure 5.2 Pupil with his powered model vehicle



Figure 5.3 Pupils testing their mangonels

the action and the setting.

The refining of his plans for the summer term was related by the teacher to his wider theories and beliefs, and to his long term goals for the class. These are examined in Chapters 7 and 8 respectively. By the end of the spring term, when he launched the topic in the lesson on 11 April, he had in mind the potential activities. The selection and shuffling of these would continue through the summer, guided by the overall aims and strategies he had identified.

The teacher did not plan lessons in detail until they were imminent. However he did envisage the overall flow of activity through the term and how he hoped the learning and teaching would develop. There were units of several lessons devoted to each activity, during which pupils followed their own ideas and pursued investigations without too much intervention or pressure to record. He took any opportunities for incidental teaching, and introduced more directed lessons between the units.

For the teacher then the activities in the topic were the vehicle for the learning of skills and attitudes, and to a lesser extent concepts, over the term. They introduced a shift in emphasis which he said that he felt was appropriate at that stage. He compared this to a change from a high speed trip down a motorway, closely directed by him, to an exploration of the lanes and byways at the children's own pace. The stages in that journey

TABLE 5.2 ACTIVITIES OVER THE SUMMER TERM

<u>Dates</u>	<u>Teacher's and Pupil's Actions</u>	<u>Research Activities</u>
	<u>Downhill (Chapter 9)</u>	
1 May	testing commercial toy cars	observation
2 May	reviewing pupils' responses	interview
4 May	pupils build chassis and	continue
8 May	vehicle from wood & card	observation
11 May	to test downhill	& recording
	<u>Uphill Struggles (Chapter 10)</u>	
14 May	new task introduced with	continue
15 May	bobbin 'tanks' - pupils plan	observation
18 May	tests from own questions	collect
		writing
24 May	pupils design and make	& talk from
25 May	vehicles to travel uphill	pupils &
		teacher
Half Term	teacher reviews progress and plans, meets for interview	interview
		review data
7 June	continue uphill struggles	focus
	frustrations/learning from mistakes	collection
	change of direction/new activity	of data &
		start analysis
	<u>Mangonels (Chapter 11)</u>	
12 June	model mangonels introduced, made	
15 June	& tested, pupils plan investigations	
18 June	more mangonels, pupils' ideas	continue
21 June	explored and reported to	observation
22 June	teacher in historical context	& recording
	(bicycle questions introduced & deferred)	
2 July	more mangonels - remote mechanisms designed, made & tested	selective site visits
	<u>Choices (Chapter 12)</u>	
10 July	choice of bicycle tests devised by	probe
13 July	pupils, return to powering vehicles	pupils'
	or developing mangonel	views
19 July	mechanisms, or choose own activity	exit
End of term		final
24 July	evaluation meeting	interview

are summarised in Table 5.2 and described below .

There was a lesson on the science topic on each of the dates shown. These varied in length, sometimes lasting half the day or more. At the beginning of each new activity there was a session where the teacher introduced it, often showing some materials and technique as he set the task. The main units of activities are shown in Table 5.2 with their starting dates and the chapters in which they are elaborated. A brief account of each is given below.

5.2 Downhill

Having started the class at the end of the spring term on simple investigations with toy cars rolling down ramps, the teacher continued this downhill theme after the Easter holiday. On 1 May he set them the task of finding out how the weight of the car affected the distance it ran off the ramp. More than one variable was involved in practice and some pupils had difficulties organising their tests, but the teacher reported that in general he was pleased with the pupils' results and their level of understanding. He said he was less happy with his own handling of the class discussions at the start and end of the lesson, feeling he had rushed them too much to allow time for pupils to carry out their investigations. His dilemma over the use of time was to feature again over the term. After reflection on which would be the most appropriate activities to use next to

serve his long term goals, he decided to leave toy cars and set the children a brief to design and make a simple vehicle to roll downhill. On 4 May one boy's model was shown to the class to illustrate a technique for constructing a strong chassis. Over the following week the children worked in two's and three's to make, test and modify their own vehicles. In the process, skills and insights were gained which the teacher thought could be applied later. Several pupils produced models which ran well but in some cases their concentration on the decoration of their vehicle had reduced its performance.

The teacher had meanwhile been considering possibilities for the following week, including the use of a schools TV programme from a Junior Craft and Design series. He finally decided to use the Uphill programme which showed pupils designing and making powered vehicles to climb a ramp. Although it only formed a small part of the lessons it stimulated his reflections on approaches to teaching. He contrasted his preference for teaching skills as they arose with the approach to introducing the design process in those TV programmes. As the term progressed he reviewed his beliefs, revisiting them in the light of pupils' responses to tasks. Dilemmas such as those relating to skills teaching, intervention and inquiry teaching surfaced regularly in his reflections during the study.

5.3 Uphill Struggles

To start the new challenge of the uphill activity the teacher introduced the simple cotton-reel vehicle, referred to as a bobbin tank. The children used them to devise and plan and carry out their own tests. The point of the task was to emphasise the formulating of questions and plans by pupils to investigate their own ideas. The teacher reported that he had begun with the simple bobbin tanks to switch the emphasis from construction to testing at the start of this new activity. After two lessons based on those he combined making and testing again, by setting them to power the vehicles they had made earlier so they would go uphill. The bobbin tanks and other examples on the TV programme had been seen doing this. Progress was uneven, and the teacher noted that he felt some frustration as basic construction took up a lot of time, commenting that there was a tension there in his mind as he wanted to give the children time to develop their own ideas through making, testing and modifying models, yet felt an urge to move them along. He did not resolve that in a decision until after half term however. On 7 June, two weeks after the last lesson, some children were keen to get back to their models and there was an extended session to give the class enough time. Although pupils were planning and persisting with their own ideas in most cases, as well as learning incidentally about friction and structures, the teacher decided that some of their difficulties were counterproductive. He commented that constructional and resource problems were limiting the value of the task and that he should have distinguished these from his wish to encourage inquiry learning. His evaluation of the

activity led him to decide to switch to another one which he had in mind for the topic, returning later in the term to the vehicles and the challenges they offered.

5.4 Mangonels

The teacher's immediate preparations for this unit of activity included checking some published resources for examples of investigations with the model siege catapults known as mangonels, making a simple demonstration one, and providing wooden bases to which pupils could add nails and sticks and rubber bands as they developed their own. When he introduced the task on 12 June he put it in a historical context; later he drew upon this to extend the work and set simulated problems for firing and controlling the models. The first challenge was for pupils to make and modify model mangonels so they could fire them accurately. Over the next two weeks they had to use those to work out what size of missiles and what position would be best for a mock siege. This required them to identify variables and plan investigations, check observations and look for patterns in results, and justify their conclusions in talk and writing. It also involved design and craft skills. A visitor to the classroom might at first have noticed only moving children, flying plasticine, simulated castle walls and unsophisticated models being frequently altered. The participants however saw purpose and progress. There was a sense of achievement and insight into their learning in the comments of the children I interviewed. During the lessons they often moved

me so they could take over the space for the testing of their models. The teacher spent much of his time with small groups of pupils, working on their ideas and problems, and took the opportunity to explore some scientific ideas of force and energy arising from the activity.

The design and construction elements were extended when pupils were set to make a mechanism to control the firing of their models. Other work could have been developed as well had time not been pressing. By now it was the beginning of July and the end of term was in sight. Only some of the activities from the teacher's original bank of possibilities had been used, but he had selected and sequenced those to promote more independent and skilful investigation by the pupils in the light of their progress as the term unfolded. Bicycles had been briefly introduced late in June but there had not been time then to explore questions and develop tests. The teacher planned to set the children this as the last activity, but as the lesson approached he decided that a more open choice was appropriate at this stage.

5.5 Choices

On 10 July, in addition to providing the opportunity to devise their own investigations using bicycles, the teacher allowed the children to choose to extend their work with mangonels, return to powering their uphill vehicles, or to negotiate activities of

their own. Many of them had brought their own bicycles and after discussing what they wanted to test, and how they planned to do it, worked in the playground and field near the classroom. Others used the craft tables in the corridor to develop their models, or worked on constructions and tests in the classroom where the bulk of the class were. Children had taken considerable responsibility for their own learning and chosen a variety of activities, not all of them scientific; for example pupils were painting, drawing, writing and working on a map of the school. Only the science topic has been traced in this study but the teacher was teaching a broad primary curriculum over the term. He also took the opportunity of the good weather to use the immediate environment for a hedgerow study which balanced the physical science and technology of the toys topic. When we met after the school year had ended he noted that it had seemed a shorter topic than he would have liked, because of interruptions during the term. He had been busy too with his in-service work for other teachers, and with interviews leading to the new job to which he would be moving after the holiday. However his evaluation of the topic was positive, and he noted the progress of the individual pupils with reference to his original intention that they should learn to plan and pursue their own investigations. Chapter 12 includes his evaluations and a look back over the term.

CHAPTER 6 SITUATION: THE SCHOOL SETTING AND THE PEOPLE IN THE STUDY; INFLUENCES ON THE TEACHERS' THINKING

6.1 Introduction

This chapter begins by describing the school setting and the people involved in this study. In the course of that description a number of more general influences on the teacher's thinking and action are noted. In the second part of the chapter these are analysed and discussed in relation to the framework introduced in Chapter 4. In that chapter the situation was defined to include the broad socio-historical context as well as the immediate setting. It was analysed under sub-headings of career, class teaching, opportunities and constraints, each divided into finer categories as described in Appendix 7. This chapter examines the evidence for the influence of these features of the situation on the three aspects of the teacher's thinking, ie his theories, planning and thinking-in-action. The relationships are traced and illustrated in more detail as the case study unfolds in the chapters that follow.

The account in this chapter draws mainly on data from interviews with the teacher over the year of the study. One set of pupil interviews and a meeting with LEA advisers also provided relevant evidence. Observations and comments during my visits to the

classroom, a sample of pupils' work, and contacts with the teacher before and after the year's study supplied further details of the school context and the teacher's career. The data used is listed in Appendix 4.

6.2 The School

Ann's Bridge Junior School, built in 1910, was originally the primary school for a village which has since grown to a small town. The community is now one of mixed private and council housing. Some families have lived there for generations but there are many more recent arrivals on newer estates. Local opportunities for employment are few and many people commute to work. Some of the jobs depend on the region's declining heavy industry. Some people travel to the large city fifteen miles away for entertainment and shopping as well as jobs. However there is plenty of space for children to play and the village is surrounded by pleasant countryside. The school population reflects the social mixture of the area. The two hundred and eighteen 7 to 11 year olds on roll at the end of the summer term 1984 included a few children from farming backgrounds. Many had fathers in skilled and semi-skilled jobs. Several professions were represented, including some teachers' children. The staff of headteacher and eight class teachers included one who had herself been a pupil at the school. This reinforced the overall impression of continuity and stability. Although there were some children in the school whose home problems were evident, there

was little sense of the pressure and tensions felt in many urban schools. Nor was there the feeling of urgency or of cultural variety that enlivens some of those schools. The pupils at Ann's Bridge appeared to share similar views and a common sense of belonging to the area. Their own experiences and local environment were the basis of much classroom work and this was encouraged by the local education authority advisers. Teachers appeared to have considerable freedom in many aspects of the curriculum and classroom organisation. The discussion of some common policies, in maths for example during my visits, and recognition of the expectations of the advisers or head did not prevent each teacher from developing his or her own classroom atmosphere. Over a school year therefore a class teacher was emphasising certain curricular priorities and socialising a new class into a particular way of working. In September 1983 the teacher in this study, George Packham, found himself inheriting class 6. The class had not previously been expected to exercise the independence or initiative he saw as important qualities, of particular relevance to scientific inquiry and problem solving. On 12 October he remarked, "they were used to a completely different approach last year". He felt that by putting more emphasis on process and thinking he was making greater demands on the class and that pupils who had achieved easily in their previous class were feeling this pressure.

The junior school was a two storey brick building on the main street. The staffroom and the head's office were on the first

floor. All the teaching rooms were on the ground floor where there was a central hall onto which the classrooms opened. A further classroom had been added later at the rear and this was where class 6 worked with George Packham. It overlooked the playground and a field bordered by hedges beyond. Direct access to these was possible from the classroom and they were used as an environmental resource and as a base for some activities.

Normally access to the classroom was along a corridor from the hall. The woodwork benches in the corridor were often in use during my observations in the summer term. Materials such as craft tools and science equipment were stored in a stock room just inside the classroom where they were available to children and other teachers as well as to George. Just outside the classroom there was a spare office that proved useful for some of the recording and interviewing done in the study. Figure 6.1 shows the ground floor plan of the school and figure 6.2 gives a detailed map of the classroom, including the seating pattern and teacher's moves recorded on a visit in March. This was the commonest arrangement but furniture was rearranged and pupils moved to suit the tasks.

This section has set the scene for the reader and indicated the type of teaching situation. It was a junior school classroom with a flexible organisation based on grouped desks, free movement and access to materials, and use of the classroom and the wider environment as a learning resource. For one year the children worked in this room with one teacher who was responsible

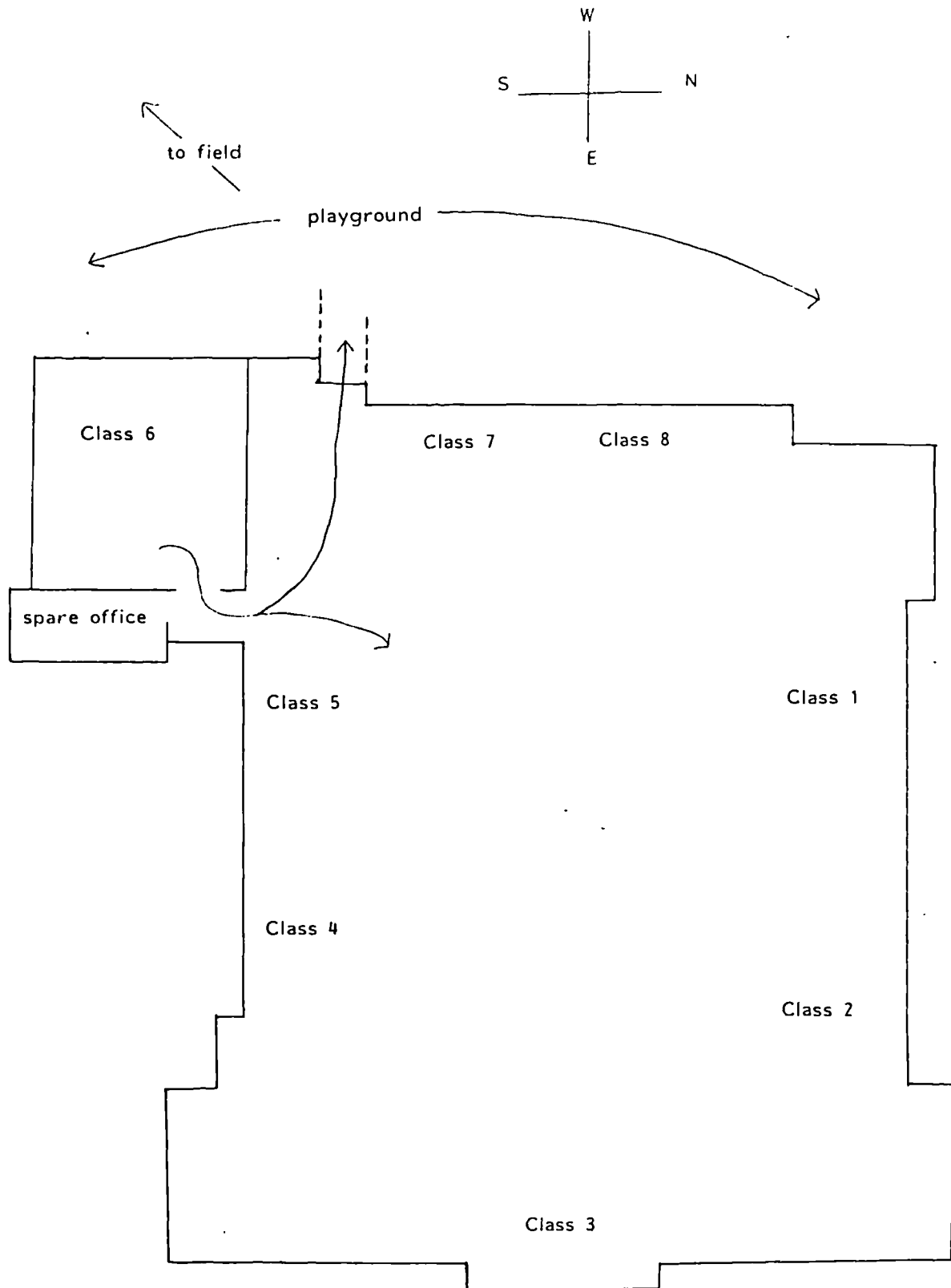

Figure 6.1 School plan based on drawing by Luke, one of the target pupils from class 6

Playground

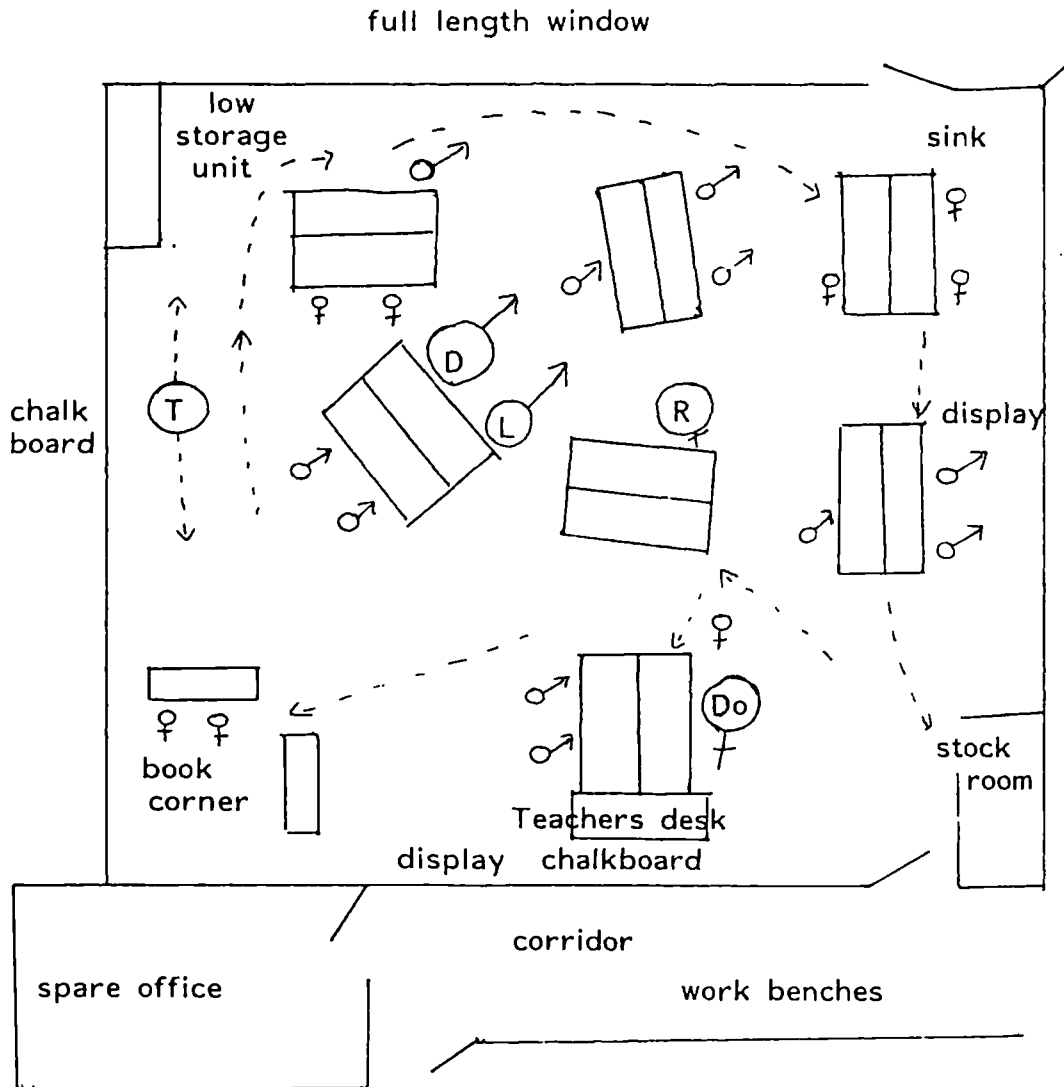

Figure 6.2 Classroom layout on a preliminary observation visit (showing characteristic starting point and opening circuit of teacher T and, the seating of pupils pm 19/3/84.)

Target pupils identified:

- | | | | |
|--|---------|--|--------|
| | Dorothy | | Rachel |
| | Luke | | Danny |

for the whole curriculum. He had considerable autonomy over the organisation of that curriculum, the room and the timetable. At times the class would be gathered together for lessons; sometimes they would work individually at their desks, for example using maths books. The day often began with a variety of activities set out for groups of pupils; groups or pairs worked together at different times of the day on related tasks within a common theme, as in the science topic to be reported. Much of the learning was planned around topics which involved several subject areas, and with reference to pupils' interests and individual needs.

A class teacher has both enormous freedom and responsibility for children and their learning across the curriculum over a year; the absence of any significant changeover of pupils or teachers, or of any team teaching, reinforced this. The classroom base and climate are correspondingly important for the pupils. Many features of this picture were common in British primary schools in the 1970's and 1980's. For example children in junior schools surveyed by HMI in 1975 to 1977 were rarely taught by another teacher for more than 5 hours per week (DES, 1978).

The classroom setting could be seen as an expression of a loose ideology of primary education, evolving from class teaching traditions (as analysed by Alexander, 1984, ch 1) and embracing a view of learning and teaching announced in the Plowden report

(Central Advisory Council for Education, 1967). Alexander (1984) has pointed out that primary teachers usually express these views as a philosophy or tradition of primary education, rather than recognising them as an ideology. The teacher's theories were influenced by this ideology, mediated through LEA advisers and school examples as discussed later, and were reflected in his organisation of the classroom and the teaching. The opportunities and constraints of the particular context affected his planning and classroom thinking and action - the influence of resources, time, and the character of the class are examined later in this chapter.

6.3 The Children

Class six contained fourteen boys and fourteen girls aged nine and ten. Early in the school year, at our interview on 12 October, George Packham had described the class as "pretty homogenous, none very dull or bright, all able to read pretty well, and all but three able to manipulate numbers". He had stressed that most of them were happy and balanced but pointed out that he was working on building their independence, positive self-images, and willingness to take more responsibility. It was clear from the start that it would not be possible to follow each pupil's activities closely during the observation of lessons. Some sampling of children for particular attention was needed to provide the detailed data on their actions and the teacher's interactions with them throughout the term's observations. The

basis for the sampling had to be explicit and related to the teacher's intentions and the concerns of the study. In the spring term George suggested pairs of pupils who were working together, commenting on attributes he saw as particularly relevant for the work, such as persistence.

Following that initial discussion on 20 March the sample was agreed at the interview on 12 April. Bearing in mind the need to include in the sample boys and girls who could be observed and interviewed by an outsider, George nominated pupils in whom he perceived relevant differences. He referred to their approaches to work, their inferred intelligence and abilities, and their personalities. We discussed his suggestions in the light of the broad aims he had for the impending project. For example, consideration of pupils who had been successful in a less active learning situation than he was planning led us to include in the initial larger sample two girls whom he perceived as

much more .. mm .. intelligent in the sense that we normally measure intelligence like say Rebecca and Jenny who are very clever girls .. who work neatly and quickly and who are .. they're achievers in the normal way of academic work . possibly won't operate quite so well. ((ie in the more open-ended tasks he would be setting)).
(Interview 12/4/84)

In this way a small number of friendship groups were selected as the starting point for the pupil sample. Out of those came the four target children - Luke, Danny, Rebecca and Dorothy - on whom detailed data was collected throughout the summer term. Those children are described here along with their teacher's

perceptions of them at this stage.

Luke and Danny worked together much of the time and appeared to have settled on complementary roles to make an efficient team. George perceived them as contrasting characters. LUKE he described as very organised, intelligent and a fast worker. In the lessons I observed he certainly got to grips very quickly with practical problems, raced ahead and almost used his partner, Danny, as a technician to realise some of his ideas. Those ideas may have been stimulated by his play out of school with constructional toys and by larger-scale practical activities such as car repairs with his father. He was somewhat uncertain with an outsider at first and it was easier to elicit his ideas as he worked on a task than it was during individual interviews. His reserve, and a certain lack of confidence, were attributed by George to the broken family situation (Luke lived with his father). He was also the youngest pupil in the class, being nine years and eleven months old at the end of the school year.

Luke's partner DANNY was one of the older pupils at ten years and nine months. When Luke went to Spain for a holiday during the summer term Danny teamed up with another boy, Ivor, and worked successfully playing a rather different role. Danny was described by George as a little more pedestrian and not so intelligent or fast working as Luke. He was able to express his ideas and findings in numbers and writing and to talk quite fluently. At interviews he seemed confident and clear about his

ideas but economical with words.

REBECCA on the other hand was extremely forthcoming and took the initiative in our interviews. She was ten years eight months at the end of the study. She generally worked with her friend Jenny but their group gained and lost girls and for a while in the summer term Rebecca worked with another boy and girl. She was able to reflect on the pros and cons of working with other pupils and also on her tendency to worry about some of the problems and tasks set during the summer term's project. Those worries sometimes resulted in her roving around the room and talking with various pupils. Once settled and confident with the task she was capable of concentrated work of a high standard. At the time of nominating Rebecca and Jenny, George had spoken of her approach to work and wondered how they would cope with the more open-ended work planned for the summer term (12 April, quoted above). He had also just found that their detailed and carefully presented findings from an experiment had been adjusted to show what they thought were the expected results.

DOROTHY was ten years and five months at the end of the summer term. She almost always worked with her friend Debbie but often followed her own ideas and directed the activities while Debbie looked on. George described them as fairly bright but not very assertive, and contrasted them with "the hugely competent children like Luke". Despite this, and the lack of success Dorothy had in her previous class, he anticipated she and Debbie

were capable of tackling with some flair the work he planned for the summer term. Although talkative in class Dorothy was less at ease in interviews until more personal information had been shared and she had some successes with the tasks to discuss. En route to those successes there were many difficulties and frustrations, accompanied in some cases by considerable "messaging about", in her own words. Dorothy often followed through her own ideas and designs despite advice. As well as going her own way she could sometimes be seen at the end of a lesson working furiously to make up for lost time or complete a product after everyone else had responded to the instructions to tidy up. Similarly at the start of a lesson she sometimes appeared to be ignoring the teacher as he set the task.

Debbie and Dorothy were joined for a while by a third girl and there were some other small changes in the composition of groups over the term as noted above. However the working partnerships around the room were fairly stable. For a time this seemed in danger of being exaggerated by George's concern not to make my observations more difficult than they already were in the midst of a project where free movement and choice by pupils was the norm. The risk of distorting the observed situation was hinted at in our negotiations on 12 April, when George commented

yes I think as well I'm going to have to ... insist a little bit more they work in .. static groups .. the groups that they've got now (you know) stay with those .. generally they will anyway. (Interview 12/4/84)

This was resolved around half term when some pupils wished to

change groups. I assured George that he should follow his normal practice and allow the freedom that he judged appropriate rather than impose restrictions dictated by involvement in the research. This he did, balancing the pupils' wishes with the task demands and his knowledge of individuals. In most cases children worked in twos or threes on practical investigations and construction, breaking down the task and taking different roles in some instances, and pursuing individual interests in others. Two boys were notably isolated and needed the teacher's attention for academic and social reasons. One, William, produced some interesting designs and constructions in the course of the summer term which will be described in the account. The other, Jimmy, was more evident in his demands on the teacher's time. He was the only child who took an appreciable time to accept the presence of an observer and recording equipment in the classroom. The rest of the class continued their investigations while I was making notes or recording. After the initial familiarisation in the spring term they were not obviously distracted by videorecording during whole class sessions. Such plenary discussions or task setting, when the teacher directed the whole class, were a small but significant part of the work. There were also many short impromptu sessions when he drew their attention to someone's progress or took an opportunity to make a teaching point.

6.4 The Teacher

The teacher in this study, George Packham, usually travelled the seventeen miles to school with a colleague who drove from the same large city. He arrived in his classroom around eight thirty to get it ready for the nine o'clock start. Jimmy often came in while he was doing this; George recognised it as an opportunity for the relaxed contacts the boy needed and talked informally with Jimmy while preparing. When the rest of the children arrived they often began the day with a range of activities that the teacher had set out and worked on those until playtime or assembly. The science lessons did not occur at any fixed point in the day and could run for as long as the teacher deemed necessary. There were of course constraints such as the timetabling of the hall, the need to attend to other aspects of the curriculum, and the interruptions that are a feature of primary school life. Over the summer term there were even more interruptions than the teacher was used to. Looking back on 24 July he said that he felt the number of closures of the school, and his absences for job interviews and in-service activities, had been particularly disruptive. Throughout the study teachers were also involved in a pay dispute during which they were not in their classrooms outside normal teaching hours.

At the end of the day George sometimes had a lift home with the same teacher but if he worked late would catch two buses back. Over weekends and in the school holidays the good bus service also gave him and his family access to the hilly country on the other side of the city. With his wife and three sons he would go

walking whenever possible. George valued such experiences for children and took his class out of school locally and farther afield. For example, I first made informal contact with George's class as they walked through a park following a visit to a working water wheel. George's own childhood had been spent in urban Manchester. At thirteen he had moved to the outskirts of London, near Epping Forest. The boy's grammar school he had attended there became a comprehensive, which led to more opportunities for social mixing in and out of school. Motor bikes had been a focus for social and practical activities when he was a teenager. The opportunities he had for informal learning from such experiences were contrasted by him with the more passive leisure pursuits of many of his present pupils. His views on the importance of experience and activities out of school as a foundation for learning are explored further in the analysis of his theories in Chapter 7.

After school George had worked in Canada for a year before taking a degree in Geology at a northern university. Following a temporary job in a local planning department he spent a year training to teach at the Polytechnic in the city where he then settled. His teaching practices were in middle schools and his course trained him as a class teacher for the seven to thirteen age group, with some specialisation in science. However when he qualified in 1977 there was a sudden shortage of jobs in primary and middle schools. He found a temporary post teaching physics at a comprehensive school in a nearby local education authority

(LEA). This proved to be a demanding but valuable year. His own adaptability and persistence was complemented by the support of a head of department who later became science adviser for the authority. His learning over that year was an important ingredient in his subsequent success and standing in primary science. During his year in secondary school he used his free periods to do some primary school teaching and then he gained a post as a class teacher in a junior school. After three years he moved to Ann's Bridge school where he had responsibility for science and mathematics as well as teaching his class. This post of responsibility involved offering support and consultancy in science and mathematics to other teachers in the school as well as organising resources and developing policies. At the time of the study George had been at Ann's Bridge for two years and was well established as a class teacher and science consultant. He had considerable autonomy, enjoyed his teaching and took wider responsibilities. Outside the school he played an important part in the local authority's primary science group and worked closely with the primary adviser and the recently appointed science adviser. He expressed some concern that he was being labelled as a science teacher because of these activities, whereas he saw himself as a general primary teacher with interests across the curriculum:

its been very galling to me that over the last .. errh... couple of months.. that advisers have been coming up saying "here you want to get down to . you know some work across the curriculum . not just science" and I think "what are you talking about?" (Interview 12/10/83)

Although it was only possible to collect data and observe lessons on science in this study during the summer term he was in fact teaching the rest of the primary curriculum. He organised class lessons and individual work to extend pupils' experiences and skills in mathematics and language and art as well as applying these in the topic. Geographical and historical work was introduced into topics. Games and physical education were taught, although sporting activities and clubs such as chess which he ran were curtailed by the current teachers' action over a pay dispute. George had at various times interests in English, mathematics and environmental studies; in his next post he developed expertise with microcomputers.

By the time of this study George was thirty two and had been encouraged to seek promotion within the authority. During the summer term he was appointed as deputy head of a primary school so the term to be described was in fact his last at Ann's Bridge. The new job was to prove quite a different challenge. At our meeting after the term ended he told me that he felt his teaching had been limited by the concern with job applications for the first half of the summer term. I had not detected this on my visits. My impression as an observer had been of a well-established teacher able to create a classroom and atmosphere in which he and his pupils could try out their ideas. In our conversations together there had been little evidence of anxiety or distraction. However George had indicated in our early interviews how some of the pressures he felt from advisers

and others were accentuated by his consciousness of career possibilities.

At any time teachers' principles and classroom practice may be influenced by what they feel parents, headteachers or colleagues expect of them. In George's case he was committed to providing time for pupils to pursue their ideas without undue interference or demand for products. However, he was conscious of internal and external constraints in putting this into practice. At our interview on 12 October he remarked

I think that's a fault of all teachers . and me especially . that you say "Oh let them play" but you can almost feel the head and the parents pushing ((laughs)) pushing you forward to go and stick your nose in. Of course you've also got a guy ((a teaching colleague)) saying you haven't done your RE this year and you've not done your art or practical maths very much
(Interview 12/10/83)

The pressures to intervene, and to attend to a wide curriculum, are commonly experienced by class teachers. But the priorities of the LEA were particularly significant in this case. For instance, referring to pupils recording of their work through writing, pictures, models, etc, George commented

yes I get them to record as well because I still think that's necessary . even if its a rudimentary recording . because in (this LEA) we go in for elaborate recording as you probably know
(Interview 12/10/83)

And these were the influences that were felt more acutely at this stage when he was conscious of career possibilities, as he mentioned at our next interview on 20 March

largely because .. because we've got people coming into the classroom who'd like to say "Well . where's the evidence of what you've been doing?" and that could be the reasons why this year when I'm a little bit more conscious about ... career advancement I'm getting things ... recorded .. much more tightly .. whereas before I was .. less concerned about having a neat piece of writing at the end of it.
(Interview 20/3/84)

The stress on a finished product and display in this LEA was known to those who visited its schools, as I did, and mentioned by George over the year when he commented on LEA priorities. He summarised many of those comments when he talked of on 13 July as I gave him a lift home. Apart from their emphasis on presentation, he felt his goals for the science topic were not inconsistent with the LEA priorities. On this and other occasions he noted how in general he was very much in sympathy with the spirit of the authority's policies, but able to stand back and examine the underlying assumptions critically. He commented on the difficulty he found in getting colleagues to ask those deeper questions, suggesting that was because they were concerned with coping and felt threatened by querying the value of what they were doing. George attributed his own confidence in this respect partly to his experience of working with the advisers and getting to know them individually, and partly to the recognition of shared beliefs. He instanced their common concern to foster persistence, active learning, individualised work, and curriculum integration. The LEA's view was summarised by a primary adviser when I met him and the science adviser on 18 July to discuss the study. He emphasised the use of first hand experiences and pupils' interests in a cross-curriculum approach

to promote individualised active learning.

George gave the impression of someone who was confident and ready to examine both received ideas and his own theories and practice. Indeed his involvement in this study was based on a wish to do just that. His background and professional development have been described to convey the personal and historical context in which he had developed his beliefs and his skills in the role of a class teacher with a specialist strength. A link between his personal beliefs and a loosely defined educational ideology has been indicated. It appeared that personal contact, and the recognition of power and influence over his work, played a part in the mediation of a primary school tradition by advisers who were a powerful influence in a small education authority. Challenges to some of the tenets of that tradition were growing at the time of the study. For instance, on 18 May we discussed a press report of an argument for more specialised subject studies in primary education by the chief HMI (Bolton, 1984). George was unhappy about this pressure, like many class teachers.

A teachers' professional and personal history interact with the changing social climate and educational ideologies. These provide the broader context for his thinking and practice, and their influence was analysed in this case under the sub-heading of career. This section has introduced the teacher and his pupils and pointed to some features whose relationships with aspects of his thinking will be explored in the study.

6.5 The Researcher

The influence of my presence was explored with the teacher and pupils before, during, and at the end of the study. At our final meeting on 24 July George said that he had become used to my presence at an early stage and had not felt his performance was hampered, although his involvement in the study had been experienced as one more pressure. He stressed that normally he would spend much time planning and thinking, even if the commitment to the research had made him plan more explicitly and ensure that time was spent on the science work when I arrived. He commented that the presence of an interested party and an observer had been welcome.

In their comments at the last interviews on 13 July the target pupils told me they had come to take me for granted, learnt to ignore the video, and all associated my presence with the science lessons. Another boy, Mark, had summed up how the class forgot about my recording and got on with experiments when I arrived. He illustrated how I became an accepted feature of the classroom by using me as a reference point in describing a lesson, laughing as he located some action "after you got covered in glue". While observing I placed myself as unobtrusively as possible, often starting by the teacher's desk as he introduced the lesson from the other board, or recording from the far corner by the low storage unit (see figure 6.2). As the teacher and pupils moved

around I sometimes needed to find a better vantage point, and at other times the children needed me out of the way as their investigations demanded more space. In the previous term my experience as a tutor and observer in classrooms over the years had been sharpened in a small-scale study in another school. I had also practised observation and record-keeping in this classroom before data collection began.

As a former class teacher with responsibility for primary science I could appreciate the teacher's situation. Ten years' experience of training primary teachers in this region had informed me of the shared features of primary classrooms and the distinctive aspects of particular settings. If time spent in a variety of schools as a teacher, helper or observer with students was helpful, so was my involvement with serving teachers and advisers on in-service activities. I had first worked with George as a tutor during his training at the Polytechnic and some years later as the organiser of an in-service course that generated the LEA primary science group which he eventually co-ordinated. We met socially from time to time over the years and these contacts led easily into our planning for this study and my presence in his classroom. Care had to be taken to define the stance I took in these situations and avoid lapsing into more familiar roles during data collection, as discussed in Chapter 2.

6.6 Relationships Between the Situation and the Teacher's Thinking

In the course of describing the setting and introducing the people involved in this study a number of influences on George's thinking have been introduced. The relationships will now be explored using the framework developed in Chapter 4. There the situation was depicted as simply influencing all three aspects of thinking (see figure 4.3) and it was noted that the analysis of the situation would be structured under sub-headings of career, class-teaching, opportunities and constraints. In that analysis it was possible to distinguish different relationships between each of those and the three aspects of George's thinking.

6.6.1 The Teacher's Theories

George's theories were most obviously related to the categories grouped under career, which included his personal background and his professional development, and influences on those from people and educational ideas. The difficulty of confirming the associations between ideologies and classroom effects were noted by Calderhead (1984). In this case a relationship between ideology and the teacher's thinking in terms of his stated theories or priorities has been illustrated, showing the role of colleagues and superiors in mediating this. To be integrated into his theories this ideology of primary education had also to be consistent with his personal beliefs, and it was not accepted uncritically as a package. Case study can explore relationships between external influences, personal experience and

characteristics, and professional thinking and practice. In this case these influences on George's beliefs and knowledge are pursued in Chapter 7. His background in science was an important ingredient, but the most influential was his view of learning and teaching, developed through his experience as a class teacher.

The class teacher is so characteristic a feature of primary schools that the experience and assumptions of the role may be taken for granted. In this case features of that role were analysed under four categories to trace influences on George's thinking. The first concerned approaches to organising and teaching a class in which wider educational beliefs were translated into practice. Closely allied to this was the diffuse role of a primary teacher who also had responsibilities for children's social needs, for specific areas of the curriculum, and for non-teaching functions ranging from resource provision to seeing that fences were repaired! Further categories concerned the pupils as individuals, and the class. George's experience as a primary teacher who worked with one class for a year was reflected in his beliefs and skills, and the class teaching situation also influenced his thinking as he planned.

6.6.2 Planning

In this chapter George's perceptions of the class and of individual pupils have been cited from our early interviews. His judgement of the character of the class, expressed on 12 October,

influenced the teaching approaches he planned and the priorities he identified for their learning. On the one hand his view of the class as "pretty homogenous", "very compact" in their abilities led him to conclude that he could do a class project or topic "without any kind of qualms . whereas sometimes you would have some children who were zooming away - and others who were struggling". On the other hand he had diagnosed the need to increase their independence when he was drawing up his plans for the year and initiating the class into his ways of working and expectations. The importance of establishing the academic and social framework early in the year is taken for granted by experienced teachers and has been recognised by researchers as significant in terms of later planning (eg Clark and Yinger, 1980; Smith, Stead and Wilson, 1985). The teacher's perception of the particularity of each class remains however as an influence on plans and decisions over the year. For example on 14 May over lunch George explained his decision to shift at that point to a new activity by saying "I don't think I'll press on any further because this is a class that .. gets bored very quickly".

George's planning was strongly influenced by opportunities that his situation provided. The immediate environment, the teacher's confidence with science and in his teaching, and his autonomy over curriculum decisions all increased the opportunities. The time of year was cited more than once as significant in reducing some of the other felt pressures and constraints. For instance

on 12 April George anticipated

that towards the end of the year .. I hope a fairly successful year .. I can relax a bit on all the other areas of the curriculum and say to the children "you have time now to develop what you want to do".
(Interview 12/4/84)

Later he added

I don't think I could do that throughout the year but I think in the short term in the summer especially you feel a little bit more as if you can let the reins go
(Interview 12/4/84)

He had previously contrasted the pressure to make junior school pupils achieve in many areas of the curriculum with the opportunity in infant schools for younger pupils to pursue more sustained work. Concerns with time were much in evidence in George's comments, but in more than one sense. The time of the year influenced the teacher's plans and practice. The pressures of time were again felt as the end of the year approached, and in his final evaluation George elaborated on the way he felt lack of time had constrained the activities. Those themes will be illustrated in context in the appropriate chapters. One further sense in which time was experienced as a constraint was mentioned earlier in this chapter, namely the interruptions that seemed to the teacher to have restricted the flow of the project. He frequently referred to past or impending interruptions from days when the school had to close for elections, union action during a pay dispute, and his absences for interview or in-service activity. His imagery at the start and end of the project reflected a concern with the distribution of time as well as the

total amount available. On 2 May he commented that he was "not quite sure where I'm going to go from here .. with the term being so bitty" and on 24 July he disagreed with my suggestion that it had been a fairly long project:

George: I don't think so actually . I think it was . as it turned out a fairly short one

R: was it?

George: I would have liked longer

R: you'd have liked to do it over two terms or . ?

George: no . over one longer term . rather than having too many days off

Influences on George's planning are traced further in Chapter 8 and in the account of the summer term in Chapters 9 to 12, where they are reported along with influences on his thinking-in-action.

6.6.3 Thinking-in-Action

Some of the constraints and opportunities that affected his planning were also related to George's thinking and actions in lessons. His own autonomy and confidence were evident in his interactions and decision-making as he managed open-ended lessons, encouraged pupils to pursue their own ideas, refrained from intervention, or decided to alter his plans. George's comments as he reflected upon pupils' responses and the progress of lessons are reported with the action in the appropriate chapters. They revealed a number of influences which he weighed

as he thought about his interactions with pupils and came to decisions in lessons. Many of them referred to time again. He was providing more time for pupils to try out their ideas and develop their own investigations, but in some lessons he judged it was not proving productive. On several occasions he mentioned how the pressure he felt to intervene was closely related to the constraints of time and the need to ensure that pupils achieved and covered a wide curriculum. At our half-term interview on 27 May he spoke of

(the) feeling as a teacher that you don't want to waste time .. because you know that you've only got a limited amount of time ... and you know there is a lot of things you could be doing.
(Interview 27/5/84)

He elaborated on this and on the "great tension in the feeling you've got". This tension is explored in the study through analysis of dilemmas, which are summarised in Chapter 10.

One of the most obvious constraints on classroom action and thinking is the number of pupils. The commitment to individualise learning is in tension with the responsibility for a large class. Although the nature of the lessons to be described created unpredictable and multiple demands on him, there were surprisingly few occasions when George reported these tensions or the pressures on his thinking and classroom performance. In the interview on 27 May he did comment on one particularly demanding lesson, when pupils were having difficulties with construction techniques. He noted how "because you're too busy you can't sit

back enough and think about it" and how "in these lessons .. you're trying to do too much and doing it all rather badly rather than doing one or two things well".

George also made surprisingly few references to resource constraints, apart from a few occasions when there were specific shortages such as that caused by the pupils' sudden demand for wheels. On my visits I occasionally observed pupils facing difficulties because of limited materials or unfamiliarity with their use. Sometimes these constraints influenced their solutions to problems, or led George to do some incidental teaching of craft skills. Many of the raw materials for constructing and testing were available to pupils, and the resource issue should not be seen in isolation from George's organisation and his concern to develop more independent and responsible learners.

The study reports instances of George's introduction of new techniques to the class and his associated trialling of the tasks for himself. Teachers have to try materials and activities themselves and also with a class. Both sorts of experience may be required before a new activity is integrated into a teacher's repertoire to be drawn upon in planning for other situations. If tensions are felt during the classroom action which cannot be resolved by coping strategies then questions may be raised about beliefs or knowledge. In this interpretation resource questions influence all three aspects of thinking. They may be seen at the

lowest level as simply a matter of lesson management, or at the next level as part of planning. Beyond this they have potential for extending, modifying, or even challenging the professional knowledge and beliefs held by a teacher. For example, thinking about design and craft techniques such as George tried during the study can be restricted to ensuring that children have the conditions and skills to make successful products. Or it may become an element in a teacher's repertoire which he can use for various ends, for example to foster problem-solving skills or responsibility or group co-operation. Finally it may lead to reflection on the teaching of science and technology. The development of such an internal debate in George's thinking is reported in the study, and implications for professional development and in-service work are considered in Chapter 14.

CHAPTER 7 THE TEACHER'S THEORIES

7.1 Introduction and Overview

This chapter is concerned with those features of teacher thinking included under the heading of theories. The scope of the analysis is defined first with a brief reference to the literature. The database is noted and the content of George's beliefs and knowledge analysed. Internal relationships among those are revealed and links with other aspects of thinking indicated. The detailed working out of those in practice is presented in the subsequent chapters, beginning with the dynamic relationship between George's repertoire of knowledge and his planning.

The literature reviewed in Chapter 3 contains a number of arguments for starting an account of a teacher's thinking such as this with analysis of his theories, for example Munby (1982). Aikenhead (1984) argued that the process of planning had to be understood within each teacher's frame of reference, and Morine-Dersheimer (1984) showed how a teacher's classroom interactions made more sense when related to his or her beliefs. Terms such as belief and theories inevitably have a wide range of meanings in education. The literature review revealed a variety of specialised terminology used in researching teachers' theories. The stipulated definitions and theoretical origins of

terms used in studying teachers' thoughts have multiplied. The research community is concerned that the proliferation of terminology, methodology and orientation of studies may fragment the field (e.g. Clark, 1986; Calderhead, 1987b; Verloop 1987). In the present chapter three terms are derived from the data and defined with reference to their use in the literature: repertoire, activity, and dilemma.

The review of research into teachers' theories also revealed a lack of consensus over the definition of the field. It spans teacher's personal feelings and beliefs and their principles or theories concerning persons, education, learning, teaching and the curriculum; knowledge and views about specific subject matter are also subsumed under this heading. An account of a teacher's theories has to recognise that range of potential content, the cognitive and affective aspects, and the orientation of personal knowledge toward practical concerns. In this study the teacher's theories are defined as personally held beliefs and knowledge concerning children, learning, teaching and primary science, and relating to his situation and practice.

7.2 The Data and Analysis of George's Theories

Statements made by the teacher outside lessons were the basis for the analysis of his theories presented in this chapter. These occurred largely at planned interviews and occasionally in other discussions or written communications. George's expression of

his beliefs and knowledge were volunteered, elicited and elaborated over the year in such conversations, sometimes prompted by thinking about plans or classroom actions.

The approach and agenda used in interviews was outlined in Chapter 2. The interviews in October, March and April provided a basis for analysis of George's theories, and a framework within which his aims and strategies were set. The first interview in the summer term, on 2 May, provided insights into his views of primary science; at our half-term interview, on 27 May, he elaborated on his theories. As he reviewed his plans and reflected upon classroom action over the summer term he provided evidence of his knowledge and beliefs. It was possible to witness their use in practice and instances when this led to their growth or re-examination (for example in his extended reflections on the design process, or his commentary on his views of how children learn concepts on 12 and 15 June). George's elaborations and reviews of his theories provided a range of opportunities over time to develop and validate the analysis by collecting them as they occurred, comparing them, and probing his statements. This led to the dynamic picture of the structure of one teacher's theories and their relationships with his plans and actions which is introduced in this chapter and traced in those to follow.

The data used and cited in this chapter is summarised in Appendix 4. It was analysed first by coding the transcribed interviews

under four broad subheadings concerned with George's theories of primary science, children, learning and teaching. Links among these, and with the other headings in the framework outlined in Chapter 4, were explored.

The account in this chapter begins with a discussion of George's general knowledge of science teaching and relates that to his views about primary science, then unpacks his theories concerning learning and children and returns through examination of his beliefs about teaching to his specific subject knowledge. The discussion is widened in the next section to relate this analysis of George's theories to the research literature with particular reference to the structure of his theories and their relationship to his planning and thinking-in-action. Some discrepancies and tensions which form potential dilemmas are suggested.

7.3 George's Theories of Science Teaching and Primary Science

George's knowledge and views of science education were clearly related to his experience. Unlike many primary teachers he had studied science in his degree and training, and then taught a science subject in secondary school for a year. This gave him confidence in his own knowledge-base in science education, as he explained at one of our earliest discussions on 12 October.

George: I think it's just because I feel confident with basic science . from my degree . from . during that year at comprehensive school as much as anything else (which) probably did me more . good if you like . in confidence terms / it was more the attitudes / than anything else

R: Of course the science that you were teaching there was probably quite different from what you're doing now

George: yes radically different / but at the same time because of having . having had that experience I feel confident that what I will do here isn't at the baseline going to be wrong. (Interview 12/10/84)

When necessary George could make his knowledge-base explicit. Earlier in that discussion he revealed a framework of scientific concepts, skills and attitudes that underpinned his primary science teaching. To illustrate that he showed me an example of a document he had produced for a recent in-service activity on cars (see figure 7.1) to show that the topic approach to teaching, which he supported, could be underpinned by rigorous thought about skills. Discussing the parallel with his planning for the similar topic in this study, he said that his own use of that framework was not by direct mapping of science objectives but by a process that he repeatedly labelled as intuitive.

George: I set those down there but I don't think when I'm planning a topic () "Is there fair testing there?" no I don't do that / you'd be surprised that usually you cover () you cover all the (skills)

R: but - is it skills particularly? because you mentioned one of your other things about hedgerows - where - when you were saying it would be largely attitudes/ and you mentioned some skills

George: oh yes attitudes and skills

R: is it attitudes or is it particular scientific ideas and concepts that do you structure it or what?

George: I think say in this it will be my intuitive feeling that there are certain scientific concepts of force which underlay the whole thing I just feel that

C A R S (Middle Juniors)

In this series of experiments we can see how one experience can lead logically to another and how on occasions, it is essential that one experience does precede another. In our flow chart the first pathway might be 'going downhill'.

Going Downhill

Early Experience

1. A 'play' phase where children are given one car, a ramp, a metre rule and some blocks to experiment with in whichever way they wish.
2. Most children will work on the idea of raising the ramp to make the car go further and will go on to produce a graph, others will do a table but others might just make the measurements.

- Discussion:
- a) Do we measure in a wiggly or a straight line?
 - b) Do we measure from the top or bottom of the ramp?
 - c) In reporting back and on displays the children will notice that the results vary from one group to the next.
 - d) How many tests should the children do at each height? Usually do three and take the middle one.
 - e) Is this maths or science?
3. The children are given two cars of differing performance and asked to repeat similar activities. Scientific skills include:
 - Prediction of outcome.
 - Careful measurement.
 - Comparison of results.
 - Fair test conditions.

Figure 7.1 Extract from document produced by George for work with teachers (12/10/83-TW)

intuitively that there's going to be a lot of discussion about friction and lots of discussion about things falling and putting energy in getting energy out that's the sort of thing and design of experiments seems to underly all this sort of thing (Interview 12/10/83)

The examples he gave of friction, energy and structure show how George's knowledge of subject matter provided a resource on which to draw in several ways. It suggested to him what scientific potential lay in pupils' activity and experience, and it contained knowledge of content which could be offered or transformed to assist pupils in their own construction of scientific understanding. On 15 June he summed these up in a written note as complementary ways of using his knowledge.

I think it is one of the prime obligations of the teacher to

- (i) Plan investigations and activities that are connected in some way and not a rag-bag
- (ii) Draw the children's attention to the connections between their play and everyday experiences and their work in science. This can be done in small groups.
- (iii) Occasionally offer the benefit of his experience in terms of theories he knows about, such as the way energy is changed from one form to another or stored, or some of the aspects of friction that aren't obvious, e.g. that there is friction between air and objects that fly through it. (George's note - 15/6/84)

Although he originally characterised his use of his knowledge as intuitive George was able to make it explicit, and even hold it up for examination. Reflection upon experience, and the opportunity to discuss it, led him to inspect it and articulate it on several occasions.

George's knowledge-base consisted of a store of teaching

approaches as well as a stock of underlying scientific processes and concepts. On 12 April, when we discussed his plans for the imminent summer term project, George had illustrated this. After reviewing the underlying processes in the investigations his talk turned to opportunities for teaching knowledge and concepts.

I think the thing that is obvious is . is . friction . errm how to minimise it . because when you build a working model . you've got to minimise friction and its already come up with Luke and his model .. that he left his working surfaces very rough . and I just told him that this wasn't going to be good enough because they would rub and he saw that and then he had a problem with rubber bands slipping off the spindle . so he put some cork on it and of course that completely jammed up the rubber band and he immediately saw that this was the case and he had to . cant the spindle round so the rubber band wouldn't fly off so he could minimise friction in that way .. errm . that's been a number one thing which they've got to come to terms with for real understanding of what friction is about .. I don't think .. I don't think I'd do any specific work on it .. I can't see myself dragging bricks across the playground and all that at the moment and measuring the force on them in the classical way of showing friction and testing how much friction it involves .. but it will be just part of making models.
(Interview 12/4/84)

In the example quoted here George saw pupils' practical solving of problems concerning frictional forces as basic to their real understanding of friction, but deemed it inappropriate to deploy a familiar teaching approach to represent the abstractions of friction to the children. The use he made of his stock of content knowledge, teaching approaches and exemplars was not simply an automatic withdrawal of relevant items from a bank. He could envisage alternative ways of using his knowledge in different situations.

At the start of our discussion on 27 May he had mentioned that there were alternative ways of relating his knowledge of science

and those units in his knowledge referred to as activities. He compared his present planning with that in a previous topic, on light, which was a more common approach for him to take. He said that in the present case the activities and things were leading the choice of ideas to be taught, but more often the scientific concepts would dictate his choice of activities and resources, and then the sequence would arise from the logic of what was to be learnt. He commented that either approach was suitable for topic work.

Topics were a basic element of the primary curriculum for George, often extending for a term and embracing several subject areas. In the case of science he provided explicit examples of how he related his subject knowledge to the selection and planning of topics. At a more general level he indicated ways in which his subject knowledge influenced his selection of topics to ensure balance, as he explained on 12 October.

I want to do .. three topics approximately with a few little bits in between just for variety . but three topics basically .. try and make them biological, chemical and physical . just roughly. (Interview 12/10/83)

He had indicated that some, such as the hedges topic cited above, were better for teaching attitudes, and others for skills or concepts. His experience had generated a rich store of scientific and more general curriculum knowledge organised in those large units labelled topics, as well as the intermediate ones of activities, which emerged as basic elements in his planning.

In fact over the summer term his thinking moved back and forth among potential activities and priorities for science learning. Those trips to his store of knowledge were most often concerned with skills and attitudes, and guided by his original broad aims of enabling pupils to pursue their own ideas and investigations. The underlying emphasis on process in George's thinking and practice reflected the contemporary position of the process - content debate in primary science.

The general stress on process in primary science, and the temptations of equating pupils' learning and investigations with a simplified notion of scientific method, have been critically examined in the literature review. Another development noted there was the incorporation of design and technology, sometimes all subsumed under a generalised heading of problem-solving. George himself volunteered the view that one can teach "a way of looking at the world, a general process of problem-solving that combines attitudes and skills" (12/6/84-WN).

George made no explicit statements indicating that in his mind the planning of investigations was analysed, or distinguished from problem-solving, design processes, or children's everyday strategies for testing their ideas. However in his planning and teaching over the term there was plentiful evidence, as the account in later chapters will reveal, that his thinking was analytical. He sought, for example, to provide opportunities for

pupils to pose questions and translate them into a testable form; he encouraged them to answer their own questions, asked them to check their own findings, helped them see patterns in their results, and prompted some reflection on their plans and designs.

The reasons for this richer detail from the observations of his theory in action might be methodological, i.e. the teacher's thinking was elicited in relation to his practice rather than requiring abstract elaborations of his knowledge. It could be linked to George's preference for an internalised, implicit scientific framework rather than an elaborate set of sub-skills or objectives against which activities are mapped; in the discussion on 12 October quoted earlier he had expressed his feelings when I probed about his notion of an intuitive checklist of skills.

R: You don't sort of get 123 objectives out of
 the back of/

George: no/

R: Science 5 to 13 you know or/

George: no - I think naturally its just one of
 those things that if you do that you get too
 "gr" ((he mimes tension)) crunched up
 (Interview 12/10/83)

The primary science literature used by George at the time included some publications such as those of the Science 5 to 13 Project which provided detailed objectives (Ennever and Harlen, 1972), and schemes, such as LOOK! which matched processes to activities and topics (e.g. Gilbert and Matthews, 1981-84, p14-15). Other documents and curriculum materials to which he

referred provided a more general overview of processes that should be learnt through scientific activity (e.g. DES, 1983a; Richards et al, 1985).

George had spelt out how his theory and practice were related to this body of published material. On 28 February he wrote

I liked LOOK! for ease of getting teachers to start science and the clarity of organisation of the cards. I don't like using them straight myself. I like much of the 5 - 13 stuff, especially the philosophy underlying the work, but I don't feel it to be as useful an addition to staffroom shelf as LOOK! or Active Science (James, 1977). I tend to dip into them all. (George's note 28/2/84)

In our first interview on 12 October he had referred to the HMI Discussion Paper (DES 1983a) to emphasise that a teacher's underlying analysis of science learning could be rigorous without being explicitly expressed.

It ((the HMI Discussion Paper)) makes a fallacy that just because you're not neat and tidy on paper . that you're waffly . you're not thinking clearly. (Interview 12/10/83)

In fact George's practice already showed his awareness of the need to teach specific scientific skills that were then being identified as needing attention in surveys by the APU, such as repeating measurements. The APU results were becoming available to primary teachers and the summary report for teachers produced at that time noted

the need to consider how to help children acquire those more specific science skills such as defining patterns in observations, giving explanations, predicting, hypothesising, controlling variables and planning investigations, in which children are much less competent.

(Harlen, 1983b, p 30)

The synopsis of the evidence from APU surveys relating particularly to pupils' performance in planning investigations (Harlen, 1986) was not yet available to highlight the need for more explicit attention to the stages of planning and to critical reviews of the planning process by pupils.

Rather than reflecting any gaps in George's subject knowledge, his tendency to approach pupils' planning of investigations in a rather undifferentiated way could be related to his beliefs about skills teaching and children's learning. He held theories concerning those which appeared to exercise a stronger influence on his practice of primary science than did his model of scientific knowledge or his experience of secondary teaching.

7.4 George's Theories of Primary Science and Children's Learning

Although he saw primary science as part of a longer learning sequence George distinguished it from science in secondary schooling. In our discussions on 27 May he contrasted the position of secondary science teaching with his present role.

I don't see that it is my job in a primary school to systematically teach science .. I see it's my job to give them a wide range of experiences which will enable them to make sense of science with a big S later on .. cause that's . I don't think that's what primary science is about .. not teaching discrete packets of knowledge .. it's about giving lots of experiences which will come together later on.
(Interview 27/5/84)

His general belief in the importance of experiences as a basis for learning was focussed here on the subject of science. He also drew attention to his view that scientific learning should be "applied". This was evident in his choices of activities over the summer term, many of which were later to become staple ingredients in the growing involvement of primary schools with design and technology. George made his own philosophy explicit more than once, for example on 2 May he explained the reasoning behind his plans.

So those two lessons ((i.e. making and testing vehicles down ramps)) I would anticipate being the precursors of .. of this more interesting .. far more open-ended challenge .. that would involve much more a sort of applied science () primary science is in danger of just becoming pure science/which is nonsense .. because children at this age aren't going to () their main interest isn't in pure science/now I think it would be more sensible at this age with the ideals we've got .. to do lots more applied science. (Interview 2/5/84)

A few minutes later he generalised this to explain how his beliefs guided his choice of tasks.

I suppose it's because it actually concurs with my basic philosophy that they .. will want to apply what they've learnt .. it's no good learning something unless you apply it. (Interview 2/5/84)

Those quotations locate his theory of science learning within a general view of children and how they learn. The role of experiences, in and out of school, was also often cited by George in his comments on pupils and learning. Sometimes it was coupled with reference to the term play, emphasising the need for exploration of materials and for active, personal experience before more structured learning was appropriate. For instance,

on 12 October, after telling me how the children were enthusiastically building models with the Legotechnic construction kit he had introduced in the activity sessions at the start of the day, he remarked "That's an important one isn't it? To let them play first of all."

Out of school leisure activities and experiences were also noted as an important foundation for more systematic learning. George commented on their absence or highlighted exceptions where, for example, boys such as Luke had played with technical kits at home. More positive examples were given too during the summer term's action, and when he talked on 27 May of the various experiences of friction which the children brought to their work.

Yes out of school things like ermm .. slippery shoes and non-slippery shoes .. yeh ice and sliding on ice .. what makes a good slide and what makes a bad slide ermm () bike brakes and things like that .. making their bikes run smoothly .. they've obviously had lots of experience in that way .. this is just taking it one step further (Interview 27/5/84)

George's most developed account of his views on how children learnt from experience, and of how he saw his role in this, arose from a discussion over lunch between two teaching sessions on 12 June designed to help the pupils pursue their own ideas using simple model mangonels. He said he was "in the business of giving them experiences and they may form a pattern out of it " adding " we shouldn't be trying to ram a concept down their throat". He felt that ideas and experiences, for example of energy, should fit together over time and form a foundation.

They could come from out of school experience and play of the right sort, but many children did not get that, and the day's activities were designed to be in that vein. He felt that rather than cover all areas it was better to do what came up well. This he tried to capture in the phrase "it's almost a lucky bag" but on reading through my notes on his statement (12/6/84-WN) he wrote

1. I rather regret that for some children anything is a lucky bag but at its best its a patchwork quilt.
2. I'd like to lay a little more emphasis on the connections the children should make between the various experiences given. The quality of the learning will depend on the intellectual capacity of the child.
(George's note 15/6/84)

On 12 June he had already remarked that he would help children who were ready to make connections and individualise his treatment to match individual differences. On several occasions George had referred to his views about the individualised nature of learning, with its implications for differentiated teaching of pupils with their different experiences, abilities and learning styles. At the early stages of this study he had identified such differences when we agreed on the sample of target pupils and his attributions guided his expectation of how they would tackle the tasks in the summer term. The later account of his interactions when teaching will be seen to reflect those attributions, and his theory of individualised learning to some extent, although he had represented it as "something I play by ear anyway .. when I go into a group .. and just see what they need" (12/4/84)

Individual interests and preferences were seen by George as relevant to successful learning - for example when he commented in the interview on 20 May how some children liked investigations, and others preferred doing just what they were told. For all children he held a general principle that interest and motivation were important, and more likely to be present when they were following their own ideas.

George: If the idea in the first place came from the children/ it's most likely that they will just carry on going along the same road for a fairly long way .. because they started from a point where they want to be interested () if they started from a point where I'm interested .. they're not likely to have the same motivation
(Interview 20/3/84)

George's belief in the importance of knowledge being applied was noted earlier, and was related to his view of motivation. For instance in our interview on 2 May he justified his plan for a little competition by saying "They'd want to use their new knowledge .. and certainly not many of us would find the idea of a competition easy to resist."

Surprisingly little evidence was seen in his statements of the place of peer interaction, language and communication in learning. They had been anticipated in the initial categorisation. His teaching practice supplemented collaborative work in small groups with some plenary sessions at which pupils reported and discussed their ideas. His strategy of reducing the pressure of written recording over the term limited the formal

communication of findings, but he had noted in our interview on 12 October that he saw rudimentary recording as one means of "consolidating understanding".

7.5 George's Theories of Teaching

George's beliefs about teaching have been represented in the extracts quoted in relation to primary science, and to children's learning. His views about children and learning appeared to have a stronger influence on his teaching theories than the claims of subjects. This was evident in his extended deliberations over the use of the TV programmes 'Downhill' and 'Uphill' which introduced a formally defined design process and instruction in craft skills. George noted on several occasions, for example on 14 May after reviewing a programme, that he preferred to teach skills as the need arose because that was more motivating and would seem relevant to pupils. His deliberations over approaches to the teaching of skills are followed in the case study. They reflected tensions between aspects of his theories, the influence of actions and new ideas.

A related dilemma, developed in the study, concerned the type and extent of interventions a teacher should make. In all our interviews leading up to the summer term George talked about his concern over how much, at what stage, and in what form he should offer his own ideas and direction. On the one hand he was concerned to provide less direction and interference so pupils

could develop their ideas and take on more responsibility for their learning. On the other hand, at the time he was confirming that strategy late in the spring term, he also pointed to the pupils' need for his intervention.

they really peter out very quickly .. probably because I'm not feeding in the right stimulus and the right equipment and the right ideas at the right time (Interview 20/3/84)

Two months later, at the interview on 27 May, he was able to summarise his resolution of his dilemmas at that stage as "where they've got ideas .. don't do much except help them in their own clarifying; where there are materials or skills be quite prescriptive"

George's modification to his view of teaching in these respects had practical implications for his interactions with pupils that were summarised in that rule. It did not exist in isolation from more general principles about teaching that he had revised. That revision was itself subsumed under a review of his beliefs and understanding of children's learning and of teaching primary science and technology. This reflection on personally held knowledge can be compared with Elbaz's model of practical knowledge held at three levels of rules of practice, practical principles, and general images of what teaching should be like (1983).

In tracing the changes in George's theories relationships were uncovered, and his feelings and personal commitment revealed.

There was also evidence of his self-awareness. He gave examples of how he viewed his own teaching and related his personal characteristics to his theories. For example in our first interview on 12 October he coupled his belief in the need for play with the tendency of all teachers "and especially me" to move in too soon. He made a more general statement later in the study, in a conversation on 13 July, when he located his own theories and approach in terms of the way "different teachers bring different models, priorities and values, and emphasise certain skills."

7.6 A Repertoire of Knowledge

George's self-awareness included insights into his knowledge base and its origins. In his account of that he introduced the term repertoire.

and usually I've done something similar to it I don't usually repeat the same but something similar .. and it gradually accretes you know .. snowballs/and so something which starts off very small in the dim and distant past has now built up into quite a wide sort of repertoire if you like (Interview 12/10/83)

He was talking here of large units held as a repertoire from which he could select vehicles for learning in a new situation. The experiences of using such units had produced a repertoire that had potential for growth and flexible use. However George was also aware that experience could lead to rigidity. Talking a little later in that interview of how he developed activities he remarked on his tendency to follow familiar pathways.

I think largely I'll repeat things which I've done and found successful () sometimes I will see a new pathway .. but I () I think its one of my failings that I want to . that I'll see too clearly what I want to do and very often don't let thing's get in the way. (Interview 12/10/83)

7.7 Discussion of the Teacher's Theories

The terms 'activity' and 'repertoire' were derived from George's first account of his thinking and were retained for the analysis and representation of his knowledge base. 'Activity' emerged as a basic unit in his use of that knowledge base when he came to planning, as demonstrated in the next chapter. This had also featured in Yinger's study of one elementary teacher (1977). The term activity has a variety of usages and connotations, for instance it may denote pupil activities during a lesson, or larger units of work. In this study it was operationally defined as constituted by one or more tasks, with a common theme or purpose, having a discrete use in his planning.

'Repertoire' was adopted to refer to the teacher's subject knowledge and the related set of exemplars and understandings that Shulman and colleagues have termed pedagogical content knowledge (e.g. Wilson, Shulman and Richert, 1986). Their perspective is that teacher's professional knowledge draws both on subject matter knowledge, including the substance and syntax of the subject, and on general pedagogical knowledge, which includes knowledge of teaching and learning principles, pupils, and classroom procedures. Both these influence the pedagogical content knowledge, which includes understanding of how a

particular topic could be taught, subject-specific issues and teaching approaches. Wilson, Shulman and Richert indicated that there is a need to explicate relationships within and between these forms of knowledge, and that at the time "how these kinds of knowledge relate to one another remains a mystery to us" (1986, p18). The elements in their logically derived model are shown in figure 7.2. The account of George's theories gives some indication of the relationship in one case, and suggests the influence of other types of knowledge and associated beliefs on his pedagogical content knowledge as depicted in figure 7.3. It also emphasises the practical orientation and personal nature of that knowledge.

In the analysis of George's theories the other elements represented in figure 7.3 were evident as well as his subject and pedagogical content knowledge. His beliefs and dilemmas about teaching in relation to science were linked to more general theories concerning education, pedagogy and curriculum. The views he held about children and learning emerged as a major determinant of how his content knowledge was used. The review of literature illustrated how a view of learning could be the basis for a model of primary science.

Ingredients in George's theory of how children learn were identified but he made no general statement of allegiance to any received learning theory. However Piagetian theory had been a major influence on primary science and on the ideology of primary

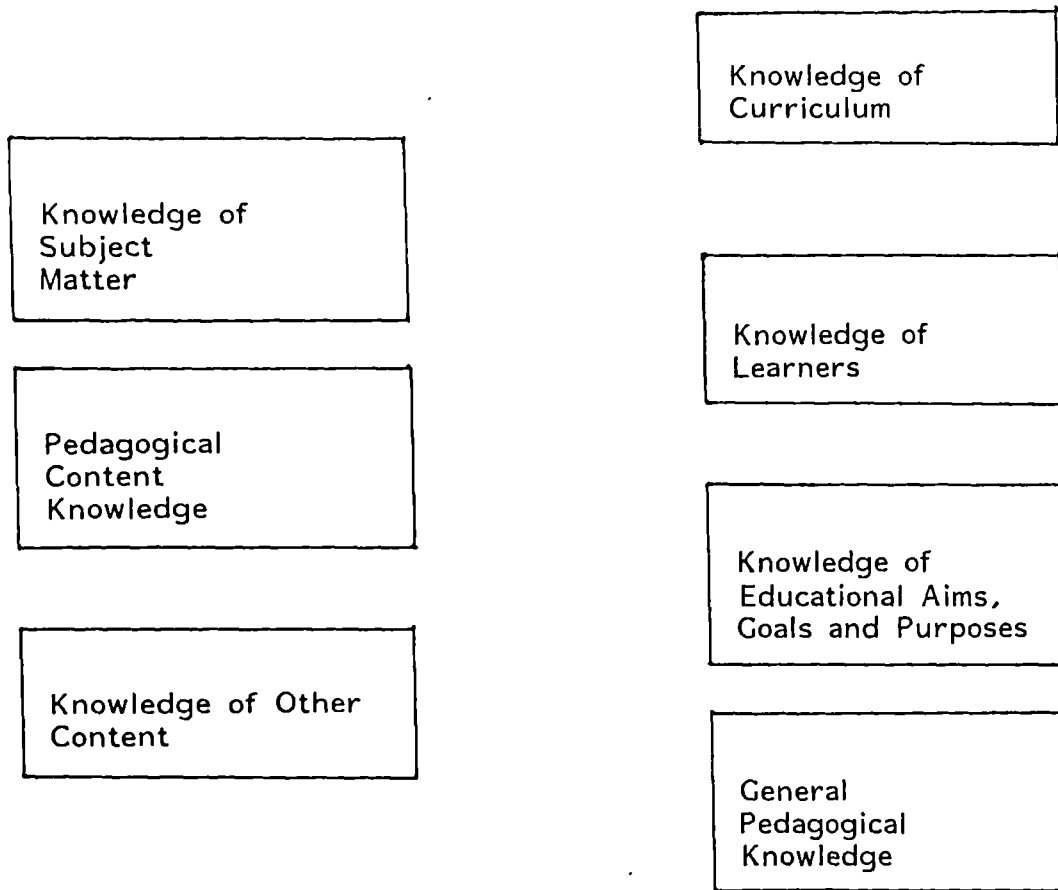

Figure 7.2 Components of teachers' knowledge base in
Wilson, Shulman and Richert (1986, figure 4.1)

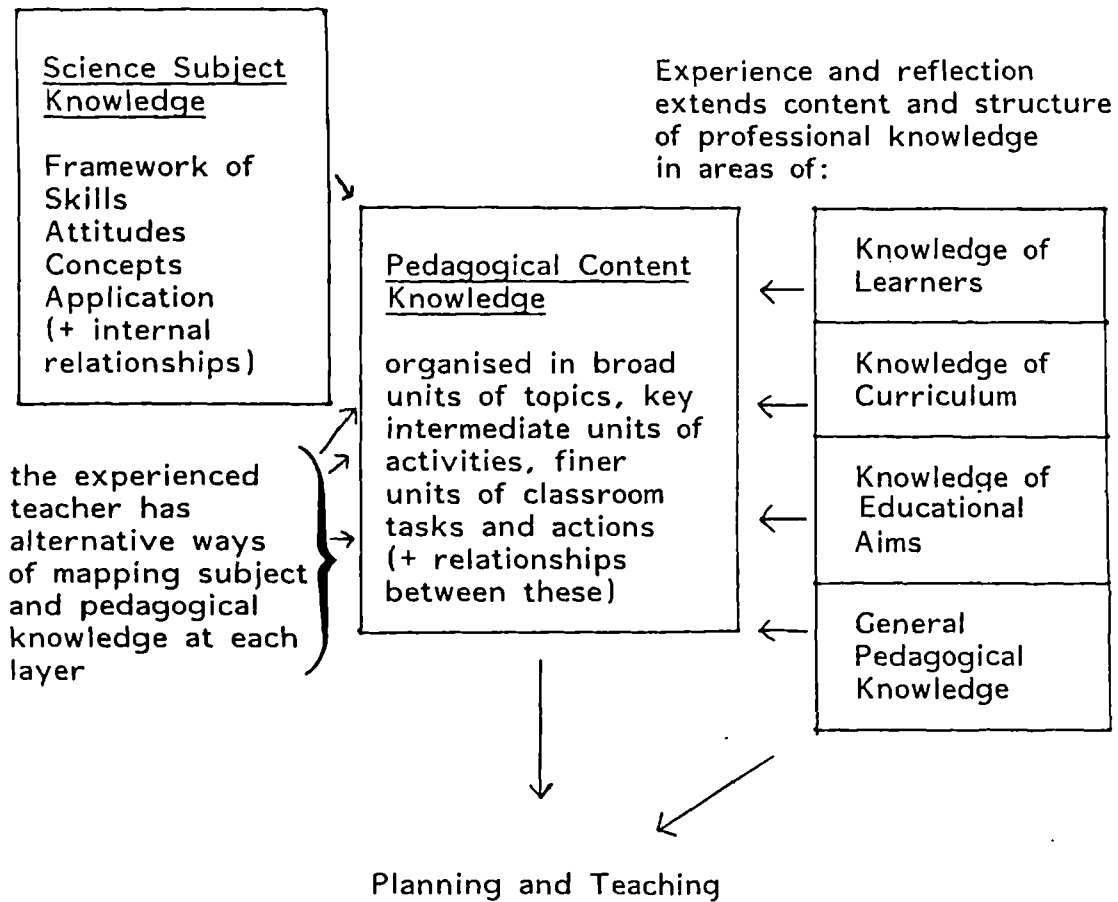

Figure 7.3 Representation of the structure of the teacher's repertoire of knowledge in terms of pedagogical content knowledge. (Developed from Wilson, Shulman and Richert, 1986, figure 4.1)

education transmitted to the LEA's schools (see Chapter 6). That loosely related set of beliefs about children, learning and primary teaching had been epitomised in 1967 by the Plowden Report (Central Advisory Council for Education, 1967). Its alliance with a view of science had been represented in the notion of discovery in the Plowden Report (para 609) and in the Nuffield Junior Science Project (1967a), as discussed in the review in Chapter 3. In fact George did not use the term discovery, and although often associated with the Nuffield project it is rarely mentioned explicitly in the teachers guides. They do however lay out a number of principles based on observation of children at work, such as the importance of experience, of starting from pupils' own questions and of active problem-solving, which featured in George's own views as analysed above. George had copies of the guides and referred to them, mentioning long after this study that it still represented many of his beliefs. He had also noted during the study that he liked the underlying philosophy of the Science 5 - 13 Project (Ennever and Harlen, 1972) which took a more analytical view of science and learning objectives but was still heavily indebted to Piaget.

George's learning theory cannot however be simply termed Piagetian, nor can his view of how concepts are learned be simply labelled as empiricist. We have seen how his thought about the way experiences lead to learning was complex and developing. Children were seen as individuals building a "patchwork quilt" of ideas from experiences which were supplemented, structured and

challenged by teaching. Learning was viewed as untidy and unpredictable but underpinned by some general principles: the need for activity and a preliminary play stage; the individual differences in quality and rate of learning; the importance of interest and motivation; and the construction of links between ideas and experiences. George was exploring through his practice a constructivist view that was at that time beginning to extend and challenge current orthodoxies about science learning. He did not make contact with any of the relevant literature however until after the study; as it became available to primary teachers he developed his own theories of science learning through reading as well as practice, showing particular interest in critiques of Piagetian psychology (e.g. McClelland, 1983) and accounts of children's alternative frameworks (e.g. Osborne and Freyberg, 1985). George did not articulate any theory of how process and concept learning necessarily related but illustrated a position that went well beyond the simple recognition that skill learning involved some content. Skills, understanding, and application were all combined in his view. This was illustrated in several comments on how problem-solving contributed to an understanding of friction, for instance that quoted earlier from our first interview on 12 April.

7.8 Relationships Between Theories and Other Aspects of Thinking

In our early discussions George's theories were seen to guide his broad aims for the term. A combination of views about science

teaching, children's learning and primary practices were orientated toward classroom possibilities in his long term planning. Beliefs and knowledge informed, and were tested against, changing plans and evaluations in a manner not captured by any simple ends-means description. George was an experienced teacher who had a rich base of personal knowledge to use in developing plans. His repertoire was not merely a collection of experience but a reorganisation of it which continued to be modified as well as increased through reflection and practice.

This extension of George's metaphor of a repertoire to capture the form and function of such organised schemes of knowledge matches that used by Schon in discussing the reflective practice of professionals. Schon (1983; 1987) writes of the repertoire that is drawn upon in bringing past experience to bear in a unique situation. The new situation is seen in terms of precedents in the professional's repertoire of examples, images, understandings and action. Reflection-in-action in Schon's sense tests possibilities from his repertoire in ways that parallel the relationships between theories and plans found in this case. Enriching of the repertoire may arise from this testing in a number of ways as illustrated in the analysis of George's thinking. Most simple perhaps was the incorporation of new ideas from sources such as published curriculum materials, carried out by testing potential uses of them in thought and practice. This will be seen particularly in Chapters 10 and 11, in relation to the model-making and testing. More complex feedback was evident

when George came to make selections from his bank of activities during the summer term. He shuffled and experimented with elements that were thereby modified and reorganised. His repertoire was enlarged and elaborated as they were redeposited.

A yet more radical review and restructuring of the repertoire may occur where theories conflict with one another or with action. In primary science the tensions between the claims of subject study and primary traditions, or between process and content, could have the potential to initiate such a review. Those conflicts did not in fact crystallise as dilemmas for the teacher during this study. However dilemmas over skills teaching and intervention did arise in the planning as illustrated already. Argyris and Schon (1974) noted the potential for theory-building of dilemmas arising from conflicts between theories-in-use and the behavioural world. Subsequently the concept of dilemmas has proved fruitful for relating theories to action in a number of studies of teaching reviewed in Chapter 3 (e.g. Berlak and Berlak, 1975; Hargreaves, 1979; Lampert, 1984, 1985, 1986; Zeichner et al 1987). Lampert's characterisation of a pedagogical dilemma as an argument with oneself (1985) is particularly relevant to the present analysis. George's internal arguments relating to his dilemmas will be followed in Chapters 9 and 10. On the basis of the evidence it will be argued that tensions associated with interactive thinking contribute to theory-building through such arguments with oneself.

Theories will also be seen to influence action and the related thinking directly. This may seem an obvious link to make but it is possible that sincerely held theories might not be in evidence once the busy life of the classroom takes over. For example in his review of studies of reading Duffy (1981) concluded that while teachers might possess theoretical orientations those did not significantly influence their teaching of reading. He concluded that this was not a rejection of reading theory but rather that "the conception of reading is mediated by classroom conditions that are more immediately crucial to the teachers than theory" (1981, p5).

Teachers experience classroom life as busy and immediate and may characterise the interactive phase as atheoretical or automatic. Active science teaching in particular may be seen as so demanding that theoretical knowledge and values are submerged and not explicitly reported. However the implicit theories of teachers have been shown to influence elementary science strongly in the work of the Planning and Teaching Intermediate Science Study (Smith and Anderson, 1983). Different theories of teaching and learning held by teachers differentially constrained their implementation of curriculum materials developed in that study and the adoption of suitable teaching approaches. Implicit theories (referred to as activity-driven, didactic and discovery) were observed and their effects on practice reported in a number of case studies (eg Roth, 1984) which are particularly relevant

for the present research, not because the typology or findings can be simply transferred to this study but because they illustrate how the influences of theories may be traced.

George's personally held values and theories about learning and teaching will be seen to exert a powerful influence over the realisation of some of his stated objectives that were not centrally important to him, for example. Thus he noted at the start of one lesson that his adoption of the design approach was not likely to be vigorously pursued because of his deeper beliefs:

I'll sort of make noises that they ought to design something - but if they don't - they just get on and start doing something that's what I'm really after I think
(Interview 2/5/84)

In this chapter George's theories have been traced from the influences and experiences that shaped them, through analysis of his beliefs and knowledge about primary science, pupils, learning and teaching to an integrated account of their structure that has been related to his plans and thinking-in-action. The next chapter begins the analysis of his planning within that frame of reference, showing how he drew upon his repertoire of knowledge. The development of that repertoire of his knowledge through experience and reflection has been linked to dilemmas which will be explored in relation to the action in subsequent chapters.

CHAPTER 8 THE TEACHER'S PLANNING

8.1 Introduction and Overview

This chapter analyses George Packham's planning for the summer term topic over the two terms leading up to it. The development and modification of those plans during the summer term is analysed in Chapters 9 to 12, where the action is also presented in chronological order.

There are several kinds of planning, associated with different time-scales and degrees of detail. Yinger (1977), in an early study of one elementary teacher, detected five kinds: termly, unit, weekly and daily. Later studies have identified similar kinds, or layers, with some additions and variations. Clark and Yinger (1986) note that studies of the dynamic relationships between these layers indicate how they nest within one another. The review of research also indicated the importance of plans at the start of the year for setting up the social and educational frame within which later planning and action occurs. This matches the experience of teachers faced each year with a new class. In a preliminary study in another school the detailed planning and teaching of a teaching team was reported within their frame of broad aims and intentions for the year (Smith, Stead and Wilson, 1985).

For this study it was therefore necessary to collect data on planning from the start of the school year. The analysis traced the development of those plans over the year and unpacked relationships among different layers of planning. It confirmed a picture of teacher planning as a nested process. George's plans for the year subsumed termly topic plans, within which units of activities lasting for several lessons were deployed. The next step down was to lesson planning; within this plans were made for sections of lessons, pupil tasks and the teacher's role. Those layers were related but the relationship between them was not simply hierarchical. A display was developed to represent this nested structure (figure 8.1).

Some situational influences on plans have been described in Chapter 6. The account of plans in this and later chapters includes further examples, such as the opportunities of local resources and the constraints of time. The relationship between theories and plans, introduced in Chapter 7 through references to George's use of his repertoire of knowledge, will be explored further in this chapter. Chapter 4 noted how images of the flow of activity were formed and focussed in planning. George's images of the term, the activities that were the key units, and the sequence of lessons will be related to the chronology of the topic as it was realised over the summer term. This is represented in figure 8.2.

8.2 The Data

The data used in this chapter was collected over the autumn term 1983 and spring term 1984. It is summarised in Appendix 4. It consists of interviews, discussions in and out of school, and notes on one lesson at the end of the spring term. That lesson served as a prelude to the summer term work and suggested some of the relationships to be explored in the analysis of George's plans and actions throughout the summer term. It is reported to provide an example of the translation of plans into actions, and to introduce the account of the term's work in the chapters which follow.

Long term planning was discussed at the interviews in October, March and April to explore George's evolving planning for the summer term topic in the light of his initial plans for the year and his evaluations over the first two terms. The procedures and agenda used for interviews have been described in Chapter 2, and summaries of the analysis are to be found in Appendix 3. The interviews gave access to George's reflections on his plans as he considered both means and ends. They were intended to provide an insight into the process of planning as well as its outcomes.

The approach allowed George to take control and make extended statements which revealed links between plans and evaluations, and with other headings in the working model. He also volunteered comments on his own planning style. George's statements could be compared and explored over time. His aims

and strategies for the summer term topic were clarified on 20 March and confirmed on 12 April before they were incorporated into the framework for this study as described in Chapter 4. They are summarised again here in Table 8.1 for reference during the discussion of his planning.

TABLE 8.1 GEORGE'S AIMS AND STRATEGIES FOR SUMMER TERM'S SCIENCE TOPIC

A. Processes and Intervention

George had been concerned from the start of the year to foster inquiry. In this general category he itemised:

- (i) pupils' readiness to pursue their own ideas, and
- (ii) to think for themselves, and
- (iii) to plan and organise their investigations.

To promote these he had strategies to test:

- (i) to avoid forcing his ideas on them;
- (ii) to allow time for development of their ideas;
- (iii) to change the form of recording and reduce the emphasis on written records.

B. Concepts and Content

At the beginning of the year George had in mind a topic on cars or transport or forces for this term's study. In later plans this developed into a topic on toys and cars which he saw as an appropriate theme for developing the skills and attitudes identified in A and the understanding of:

- (i) Friction - as a natural part of the project without direct teaching;
- (ii) Structures and rigidity - derived from the strong structure advocated for the vehicle construction and providing opportunity for direct teaching as well as incidental learning.

8.3 The Frame and Aims for the Year

Early in the year, at the interview on 12 October, George told me he was getting the class accustomed to a new way of working and was setting up the frame within which his long term aims could be realised. He remarked that "they were used to a completely different atmosphere last year and so we've come to some kind of 'modus vivendi' at the moment". He noted the sort of demands this was making on pupils to adjust to his ways and take more responsibility for their own learning, including details of classroom management such as putting things away in the right place and organising themselves, adding "it'll take a while but by Christmas we'll have come to a clear understanding ((laughing)) of where we both stand."

By 28 February, when he wrote a note commenting on that first interview, George could see progress within that frame as pupils began to take more responsibility for their learning:

I confirm that I'm still feeding bulk of ideas and method to children but beginning to feel that there is more independence and confidence to try own ideas on part of children (George's note 28/2/84)

During my visit to the class on 8 March George illustrated how his plans and strategies were seen in relation to the long-term aims. Explaining that the day often began with a choice of curriculum activities - some new and some a continuation of previous work - he noted that this served his aim of fostering

pupils' ability to choose for themselves. He added that they were getting better at this when compared to his early description in October.

This judgement was qualified however two weeks later when George articulated more specific thoughts on his own performance and the pupils' progress in relation to that overall aim of increased independence. In the interview on 20 March, referring on the previous day's lessons when the children had been set investigations using mirrors, he commented that although it seemed open-ended he was still giving them too many cues as to where to stop. He added that

and I don't feel at the moment they are saying "what happens if?" enough, they're just doing what they imagine I want them to do and stopping (interview 20/3/84)

In that comment George related his assessment of the pupils' progress to his own role. From the beginning of the year he had thought about constraints on the children's pursuit of their own ideas. He identified too much teacher direction and too little time, along with the pressures of written recording. In the summer term he intended to try strategies of intervening less, providing more undirected time and requiring fewer written records. This was not a rejection of the value of more directed teaching for appropriate ends, but rather a reference back to his long term aim of promoting independent inquiry. George judged it was about time for a shift of emphasis when he explained his plans at our interview on 20 March.

maybe what I'm doing at the moment is quite appropriate .. because I'm .. giving them lots of experiences about one particular thing so they are in fact studying it in some depth and they are in fact being successful at every stage .. because I've carefully .. graded the experiments if you like and the experiences .. so they are .. guaranteed successful and there is .. they've got something at the end of it .. which is a decent set of folders of work and they can turn round and say "yeh .. we've learnt a heck of a lot here .. and we've learnt some techniques like .. doing thing's three times .. like checking results like being sceptical about results like following something through like having an idea and testing it and deciding it was wrong in the first place .. that's the sort of thing we've done this year .. erhmm .. and it's been interesting anyway"

and so they've had that .. but then ((referring to his plans for the summer term)) possibly .. its not a sudden shift but the emphasis is different .. the emphasis is on them beginning to make more mistakes and going up more blind alleys rather than me smoothing the way for them.
(Interview 20/3/84)

George summed up his image of the contrast between the work so far and the plan for the summer term in a metaphor of a journey.

Yes .. I'd say what I've been doing this term was very much more going down the motorway .. just hurtling down at great speed and making sure we all knew where we were .. and next term I feel much more like .. exploring some of the byways .. and lanes. (Interview 20/3/84)

8.4 George's Image of the Summer Term

That metaphor of a journey captured the different sort of activity flow he envisaged for the following term. This section analyses the development of George's plans for the term as he imagined the nature and content of that flow of activities.

By the time we met on 12 April George had sharpened his image of the summer term's science. He could picture how more time would

be provided for pupils to pursue their ideas within the overall flow of activity, if all went according to plan.

I hope more and more to be giving them a chance to develop long term more and more their own ideas .. this may not happen .. this may not work .. because they're not as self-motivated as some classes I've come across but I hope that they will be able to take on .. say half a day's work .. easily developing their own ideas and trying out their own experiments .. on their own models and the artefacts that they're produced. (Interview 12/4/84)

George went on to say that by cutting down on other areas of the curriculum he would give them fairly lavish amounts of time to pursue their own interests. He had qualified his plans not only with reference to the character of this class, but also with his own wish to retain the opportunity to insert episodes of more directed work.

in spite of what I've said there will be times .. every other week say approximately when I will be giving them specific tasks that I will be saying that "we've been to the playground or whatever and we've seen swings .. can you work on this pendulum here .. and these are the constraints these are the things I want you to do" (Interview 12/4/84)

He had in fact focussed his image of the term's plan closely enough to envisage how such episodes of more teacher-led activity might structure the flow of pupil investigations.

I think what I'll .. I'll tend to do is .. as I said there'll be sort of formal type pure science sessions about once .. once a week or once a fortnight .. or so .. where I'll be telling them what I'll want to do and that may actually signal the end of a particular phase of looking at one thing. (Interview 12/4/84)

We have seen George progressively focussing his image of the summer term, within the original frame announced at the start of

the year. So far we have traced his views of the pupils' progress, his role and interactions, the strategies he will use and the way these will be deployed over the term. Now we turn to the content.

8.5 Planning the Content. Selection and Sequencing.

His definition of the topic and potential activities sharpened over the year. This was not simply a matter of filling in detail as time passed. Alternatives were weighed against his overall goals, with references to the situation and recourse to his repertoire of knowledge. By the time he introduced the first lesson a range of potential activities had been identified. The selection and sequencing of those was not fixed and would be done in the light of reflection on the action over the summer term.

George first expressed his thoughts about the content of the science topics when I interviewed him on 12 October. He described how he generally did one topic per term "with a few little bits in between" and how, over a year, he sought to balance biological, physical and chemical science topics. Although he did not repeat topics in exactly the same way he had usually done something similar, and he explained how the experiences of teaching those topics had "built up into quite a wide sort of repertoire".

He felt that his repertoire was now extensive enough for him to

make selections from it on the basis of current opportunities and his interests. There was no evidence that systematic co-ordination through the school constrained his choices. The work in the first term was related to the region's iron and steel industry, stimulated by visits to industrial museums. As the interview proceeded George explained his choice of that and the spring term topic.

R: So this year you said to yourself . before you met the kids . "these are the sort of topics I think we'll do "?

George: Yes . I just fancy doing iron and steel and I'd been to Kelham Island ((an industrial museum with a schools service)) .. and I'd been thrilled by it . it's a great start and therefore it just seemed logical to go to Abbeydale ((an older industrial hamlet)) as well to reinforce .. and because it's a good visit .. and then I just built up from there./

The next one which I'm going to do in the spring . after Christmas . even . is Ourselves . you know . our bodies?/

Because I know that this class haven't done that and also it's one of my favourite things/ and its one of those things you can just let them go on ... because once you've got them going they can do all sorts of experiments for themselves and it becomes very sort of freewheeling.
(Interview 12/10/83)

The pupils' scientific activities in October were concerned with the properties of metals. George anticipated the visits would lead naturally into technology and science related to model-making. He was uncertain how far to develop those models into the investigation of pulleys and gears at this stage as he anticipated some work on those in the third term, when I would be present. The content of the topic for the summer term was

however only tentatively and loosely defined in references to potential themes and titles, such as 'bicycles' which he had used earlier, "and things like cars and . really a topic either . entitled . cars or land transport . or . or sort of forces might be a nice topic."

By the end of February, when he wrote a comment on his remarks in that interview of 12 October, he had modified and focussed his plan for the summer term's topic.

I have changed the summer topic to 'Toys' to bring in some of the ideas of gearing and experiments with cars and bicycles. Chosen because it gives a wide area for other work in art, model making, discussion and writing; 'forces' is too abstract and I feel that the other areas would be rather contrived and lack focus. I want children to try to make own working toy in wood especially - many of these can be very simple giving chance to less able but complexity can be great for the inventive. Much of our science will derive from the process of model making and problem solving and the use toys are put to.

Regret loss of hedge topic through year because of time constraint. (George's note - 28/2/84)

The 'Toys' topic was chosen then as a more relevant and natural vehicle for activities similar to these he had anticipated earlier, but also to provide opportunities for work in other areas of the curriculum. His plan seems to have been modified to reflect his commitment to curriculum integration, and his views on children's interests and abilities.

George's note about the Hedge topic referred to his plan, mentioned on 12 October, for the class to study the nearby hedgerow at intervals over the year. He had originally intended

that in the summer term he would alternate it with the main science topic as dictated by the weather and the rhythm of work. This concern for balance and variety did in fact resurface later in the summer and a return was made to the hedge.

Toward the end of the spring term George sharpened his image of the activities that could begin such a topic on 'Toys'. He had selected one element from the range of content considered earlier, begun to translate it into tasks for pupils and himself, and located those against his general image of the activity flow. Following his general description on 12 April, of how episodes might be arranged in that flow quoted above, he had illustrated it thus.

I think it looks like we're going to start on cars and things that move up and downhill .. erhm we'll probably be doing that and we may have another sort of formal session on what happened with different weight cars or different type cars then what happens with perhaps crashing cars at the end of a run or something like that.. that may actually signal the end of that part .. of work . then in the meantime there's been children developing their own models and their own ideas with any luck over a period of half a day at a time or a day at a time at maybe the outside.
(Interview 12/4/84)

George's mental planning as he approached the summer term was focussed on that one unit where he could envisage the classroom action. It was a basis for planning lessons over one or two weeks. Although he could sketch this first activity there was little definition of detail at this stage. Nor were the later units of activities firmly in place, simply awaiting infilling as the time approached for their implementation.

8.6 Discussion of The Process and Structure of George's Planning

George's plans have been traced as they developed over time. The analysis of George's planning revealed a time-related nested process as indicated by several other studies (e.g. Joyce, 1980). Figure 8.1 represents the layers and relationships within his planning as analysed in this chapter.

Each layer identified is nested within another chronologically and logically. However links between layers can be more complex; for example, lesson planning referring back to termly plans, and each layer interacting with the teacher's beliefs and repertoire.

The model in figure 8.1 is therefore not linear, nor simply hierarchical, but represents by broken lines the openness to movement between layers. The vertical arrows indicate the flow of action as imagined (a) over the term (b) over an activity, which could involve several lessons (c) during a lesson. The horizontal arrows represents the action in real time.

Movement between the plans and repertoire was framed by the early setting of goals and ways of working, and the selection of broad termly topics. It was initially a very free movement which left many possibilities open, only tentatively reviewing potential topics and activities held in his repertoire. Activities were the key units, and several were considered briefly and set against the anticipated character of the summer term. The flow

Theories

The teacher's repertoire and beliefs

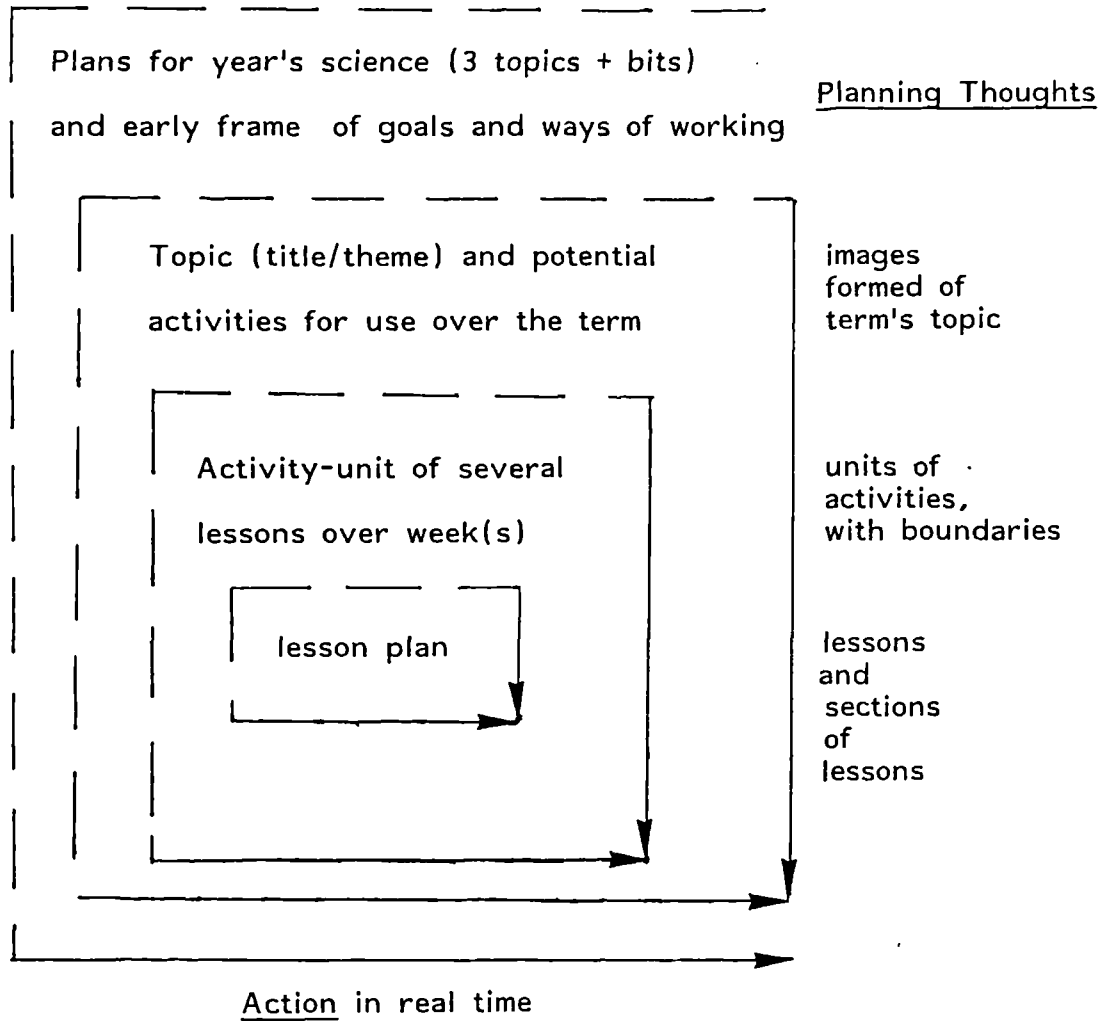

Figure 8.1 The nesting of the teacher's planning

of that term was envisaged as being composed of a sequence of those units, arranged to support his agreed aims and strategies, and bounded by interludes of more direct teaching. The overall topic theme, or title, appeared to be a linking device serving to make the ideas more concrete and relevant to pupils.

Under the title of 'Toys' George had clustered a number of loosely defined activities which would serve as vehicles for the process aims he had identified. He had not finalised his selection, nor the sequencing, and there was some overlapping of activities. Opportunities would be taken to extend specific skills and ideas through interspersed lessons and interactions.

Figure 8.2 represents that mapping of George's planning thoughts onto time. The development of the topic and activities in the context of the first two terms is indicated at the top. The main body of the figure represents the image of the summer term topic held by George as the time came to launch it. His plan is shown as flowing down through a number of bounded units over the term. The number, and the order, of those units remained to be decided. They would be selected from a stock of potential activities provisionally drawn from his repertoire. During the term his repertoire would be supplemented, for example by reference to published resources. The activities are shown in the centre of the figure, represented as sets with some overlapping. They had all sorts of associations with experience that allowed them to be brought to bear on the unique situation to come.

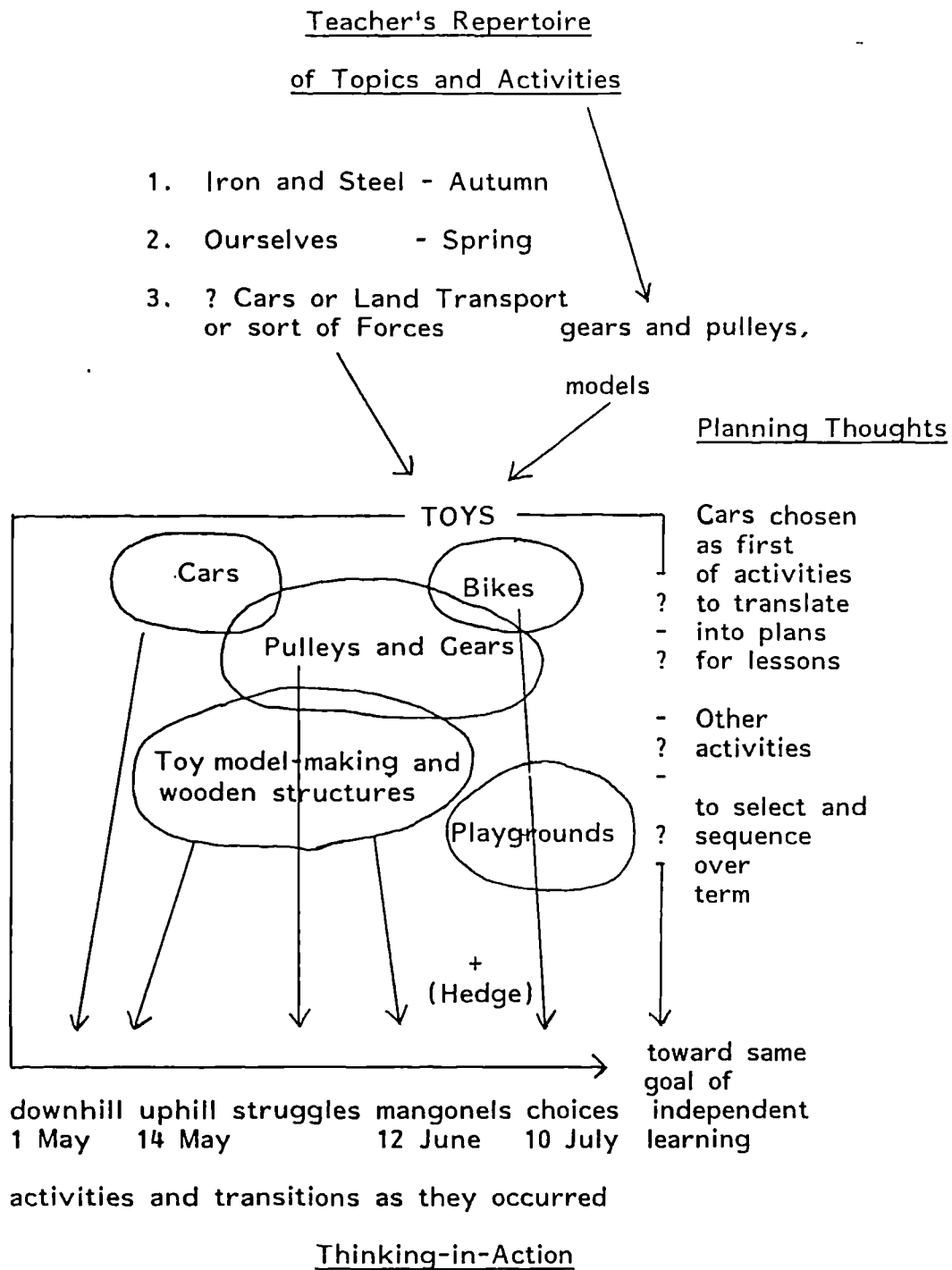

Figure 8.2 The teacher's plans for the topic related to imagined and real chronology

For instance George's reference in our interview of 12 October to the in-service work he had done based on work with cars has already been mentioned in Chapter 7. He had also remarked that "even with my class at the moment I'd probably start there", and in the event he began the topic under study with a downhill activity similar to that used in that in-service work with teachers. In the same interview George remarked on his tendency to repeat successful activities, adding "but sometimes I will see a new pathway .. but to be honest its rare because / I'll see too clearly what I want to do."

In Chapters 9 to 12 he will in fact be seen increasingly to adapt or customise activities to suit the situation as the topic progressed. For example, over the years he had used the theme of 'bicycles' with classes and developed his own teaching resources. When he came to introduce this as the last activity in the term however he did so quite differently, as will be described in Chapter 12, using his experience as a resource in reserve rather than a recipe to follow.

By the time he came to plan the early lessons George had decided which unit of activity to deploy first, reporting on 12 April that "we're going to start on cars and things that move up and downhill". In figure 8.2 the cars unit is shown therefore as mapped onto his plan, and onto the action where it began. Other units of activities used in practice are likewise mapped to

indicate approximately where they were introduced. Over the term we will see George reviewing his options in the selection and sequencing of activities, and reaching decisions about when to shift to a new one. Those decision points are dated in figure 8.2. At those points the chosen activity had to be translated into plans for lessons, tasks, and roles for pupils and teachers. In making that translation George referred to his repertoire of pedagogical knowledge, his overall aims and strategies, his evaluation of pupils' progress, and situational factors such as time constraints. Those decisions are reported in context in the chapters that follow.

8.7 Planning a Lesson

The literature review showed that generally research has found only limited evidence of teachers producing standard written plans for lessons based on the objectives model they were introduced to in their earlier training; nor have experienced teachers been found to rate lesson planning high in importance in comparison to other kinds of planning such as unit or weekly plans.

George had commented on 8 March that he still saw the need to plan for lessons and the week ahead, and could not understand teachers who did not plan. He jotted down plans in a folder which he carried in his case, and "if there's anything extra I just put a piece of paper in for that lesson" as he explained on

Lesson Plan for 10 April

Start of next term's topic - 'Toys and Games'

Running model cars down a ramp.

Objectives:

- i) get children used to using toys in a 'scientific' way
- ii) to allow children freedom to plan own work within clear restrictions of provision of resources.
- iii) provide background for later work where children will design and make their own vehicles and toys.
- iv) allow freedom to record in any way.

Materials provided:

A standard board
Cubes
Ruler
Metre rule
Graph paper
Paper
One car

per group of 2 - 4
(Friendship)

Introduction:

I want you to get into groups of 2 - 4, take (above stuff) and see what observations/experiments you can make. Within reason do what you like but try to have a plan of what you intend to do and investigate that thoroughly - don't just mess about. Please record your work in any way but each should have a recording. I'll give them about 20 minutes before break then 1-1/4 hours after suggesting they spend about 35 minutes writing/graphing.

Figure 8.3 George's written plan 10/4/84

20 March. In fact over the summer term he occasionally produced a short written plan for a lesson, although there was plentiful evidence of his mental planning for the lessons as we shall see. However at the end of the spring term he wrote a standardised plan for a lesson on 10 April which acted as a prelude to the summer term topic (figure 8.3).

Any written plan represents only a part of the teacher's intentions and mental image of the lesson, as Morine - Dersheimer (1979) noted. It may serve different purposes for different teachers, e.g. acting as an 'aide-memoire', or a working out of ideas, or as evidence to show others (Clark and Yinger, 1979; McCutcheon, 1980).

At this point George's written plan conveniently summarised his immediate intentions within the longer term plans. He was orienting the class toward the style and content of the summer term topic in a transitional lesson. It also spelt out how he intended setting their task and organising the time. When he came to introduce the lesson he followed his plan closely.

However small discrepancies between the image and the reality raised some questions for George, and for this study. To introduce the analysis of the relationship between planning and action which is pursued in the following chapters this one closes with a short description of the actual lesson on 10 April. This lesson served as a prelude to the action over the summer term and

is provided here to announce the account of that action and the associated thinking.

8.8 Putting the Plan into Practice: the First Lesson of the Topic

On the morning of 10 April I set myself up to observe and record in George's classroom. George introduced the class to a technique for building rigid structures which he had recently seen at a science fair in a local school. Several children worked on this, and George was able to show their work in the following term when the class used the technique in the science topic. The pupils continued with this and other activities in the classroom and at the work benches in the corridor for the first hour.

At 10.10 am the children were ready at their desks around the room; George was in the space by the board where he often stood to begin lessons. He described the task as a very open one of "playing with cars", for which he was providing toy cars, ramps and rulers. He told the pupils that they could investigate what they wished about the cars, but should think about the need to keep a note of any results and recall what they had learnt about repeating measurements. The pupils moved to work in friendship groups of two or three and George supplied the resources before circulating round groups. The children were running cars down slopes, at first spending most of their time setting up effective

ramps and making measurements. George gathered the class together around half past ten for a progress report before playtime. Rebecca came to the front to explain that her group were trying to find how long it took for the car to travel down the ramp. George told the class that it would be difficult to time accurately and encouraged them instead to measure the distance cars ran off the ramp. He repeated that advice after play and assembly. He told me he had been surprised so many children had opted to measure time intervals rather than length, using their own digital watches with little concern over accuracy. He pondered over the balance between providing open-ended tasks and the need for direction, suspecting he might have to give firmer guidance. He remarked that his instinct was to let them carry on but he would watch them for five or ten minutes before deciding whether to intervene.

When he talked with Luke and Danny a few minutes later he made positive remarks about their timing as he wanted to affirm their success, although other pupils who may have imitated them had done less well. He asked Luke and Danny what effect they thought different surfaces would have and they went off to investigate this. Half an hour later he asked the class to begin recording, first checking with him if necessary. Luke and Danny went to discuss how they could present their results and he suggested they used medians as they had spontaneously taken three readings of each measurement. Toward the end of the morning George reported to me that he was generally pleased with the lesson. He

judged that most children had worked out a test for themselves and got some results. A few needed direction but he had seen some interesting ideas, approaches and patterns of results - for example from Dorothy and Deborah who he said had used their initiative, applied earlier work on doubling to increase the height of the ramp regularly, and found that the distance travelled by the car did not double correspondingly. As the lesson came to an end at twelve children were coming to show him results and discuss their work.

In this lesson we can see a fairly close correspondence between plan and reality. The small surprise over the pupils' attempts to measure such fine intervals of time had led George to reflect on the balance of open-ended task and teacher direction. He was seen to defer the decision over whether to intervene and to individualise his interactions. Models which relate interactive thinking to discrepancies between the image formed in planning and the classroom reality (Morine-Dersheimer, 1979) capture some of this. Much of George's thinking in the lesson was indeed concerned with responses to pupils and fine-tuning of the plan in the light of minor discrepancies. However even those prompted a more general reflection over teacher intervention and the openness of tasks. The relationships between thinking and action promised to be more complex than simple movement from a lesson plan to a classroom reality. The chapters to follow will explore those relationships, beginning with the next lesson investigating cars rolling downhill which George would introduce after the Easter holiday.

CHAPTER 9 DOWNHILL

9.1 Introduction and Overview

The lesson described at the end of the previous chapter was a prelude to the activities in the summer term. After the Easter holidays the children's tests with toy cars were developed in the first lesson on 1 May, when they were set the task of investigating how the weight of a car affected the distance it rolled off a ramp. George looked in some detail at their work and shared his evaluation of the lesson with me in written notes and at our interview on 2 May. At that interview he talked at length about his plans. He decided to move on from the toy cars to introduce some design and construction. Over the next week, in lessons on 4, 8, and 11 May, the children were making and testing their own vehicles to run downhill.

I observed all those lessons, making field notes which are the basis for the descriptions of the activity in this chapter. George's recorded talk with the pupils is quoted. Video records of the lessons helped me check on events and my fieldnotes at this early stage of the study, and that made of the lesson on 1 May was a further stimulus to George's recall of the lesson at our interview. (It was not always possible for him to view any recording immediately after a lesson. When any videorecord was replayed to stimulate recall it was under George's control, he

TABLE 9.1 OUTLINE OF THE ACTION AND DATA IN 'DOWNHILL'

<u>Date</u>	<u>Action and Comment</u>	<u>Data</u>
1 May	Lesson rolling toy cars downhill and investigating effect of changing weight	Fieldnotes Audiotape of teacher Videotape
2 May	Interview with teacher Class discussion and writing up of work from 1 May	Audiotape Pupils' written work and teacher's notes on this
4 May 8 May 11 May	Three lessons making model vehicles and testing them downhill	Fieldnotes Audiotape of teacher. Videotape Slides

could stop it at any point, simply watch or make any comment he wished). George also provided copies of the notes he made as he assessed pupils' work. I collected written records from children and used sketches and photographs to follow the progress of their constructions. An outline of the action and the data is given in Table 9.1. Appendix 2 contains data sets relating to the lesson on 1 May and Appendix 3 includes a transcript of the interview on 2 May.

The chapter is organised to give a detailed account of the classroom activity as it developed over two weeks. It features George's interactions with the class and target pupils, illustrates his plans and evaluations in relation to the lessons, and includes some insights into his theories and the relationship between elements of his thinking and practice which were identified at this early stage. The analysis is summarised in the final discussion.

9.2 George's Plans for 1 May

The lesson before the holidays, described at the end of Chapter 8, had introduced the topic and the activity of rolling toy cars down wooden ramps. George planned to build on that trial run for the first lesson of the summer term. He summarised his objectives for 1 May in an entry in his journal:

Lesson - 1st May

Question - Do cars go further if they are heavy?

AIMS AND OBJECTIVES

1. To build on previous experience of designing and carrying out experiments.
2. Control of variables.
3. Use of complex results to arrive at logical conclusions.
4. To do above with minimum guidance.
5. Accurate measurement.
6. Calculation of median values.

(George's written plan 1/5/84)

George intended at this stage to repeat the format of a separate lesson working on a question he posed, developing more continuous pupil-centred investigations as the term progressed. His decision had been influenced by the number of disruptions there would be before half term, as he commented to me on the morning of 1 May while he prepared for the lesson. He also remarked that he was setting up today's task in a very open-ended way, involving lots of variables, and he expected pupils to have some difficulties. However he intended only to intervene when needed, and to individualise the degree to which he then directed pupils. I got myself ready to record and observe him, and his interaction with the target pupils Rebecca, Dorothy, Luke and Danny.

9.3 George's Setting of the Task on 1 May

At 10.45 that morning the class returned after playtime. They sat at their desks which were grouped round the room. George stood at the front by the board and I observed from my usual position near his desk. When he had settled the class George posed his question about whether heavier cars would go further off a ramp. He repeated it to stimulate a short discussion. This raised some conflicting predictions and explanations from pupils. For example, Mark thought heavier cars would go further "because you need more power" which the increased weight provided, but Steven thought differently.

Steven: If there's too much weight on it won't it'll push the wheels down and it won't be able to go at all.

George: and Steven do you think that if . if they put a lot of weight onto a car/

Steven and other pupils: /yeh/

George: /so much weight on it it'll push the wheels down and it'll hardly move at all?

Steven: and other pupils: yeh

George: so. that's a good idea. so those are two opposite ideas.
are you. (sh) convinced you're right Mark still?

Mark: yeh

George: you are. and how about you. you're convinced you're right?

Steven: don't know

Pupil: yeh

George: yeh right. you think you're right. what will be stopping the car going further in your opinion?

Steven: the weight

George: the weights. yeh. mmhuh.
I'm not going to tell you much about how I want you to do the experiment. John. I'm not going to tell you much about how I want you to do this experiment .. but I will tell you its very similar to the experiment we were doing before Easter .. but there's one thing different. what's that?

Pupil: we're using some weights
(Audiotape 1/5/84)

In his short introduction George had outlined the task, set the pupils thinking, and noted that he was leaving it to them to decide how to go about the investigation. He then spent a little time outlining what weights were available and discussing possible combinations they could use, and pointed out the toy vehicles, wooden ramps and blocks which could be used to raise them. The children chose their own partners to tackle the question and George suggested where they might work in the classroom or adjacent corridor. This avoided congestion and kept the target pupils within my view (as shown in figure 9.1.)

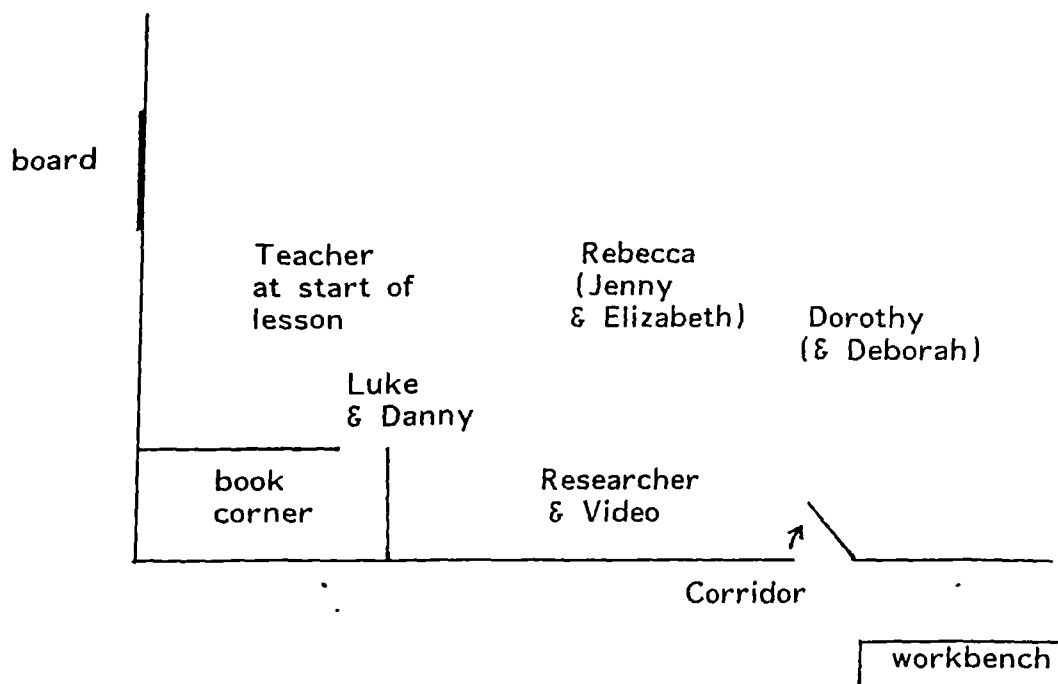

Figure 9.1 Position of target pupils on 1 May

9.4 The Action on 1 May

Once the small groups had collected weights and ramps to go with their toy vehicles George's attention shifted from class management to individual contacts. Many of these were brief checks on children's progress or responses to their problems. In a written note later in his journal he estimated that he had to give some advice on the control of variables to about half the class, although he had remarked to me early in the lesson how quickly most pupils had set their ramp at one height and only varied the weights they put into the toy vehicles. However I observed confusion among some of our target pupils, particularly Dorothy and Debbie who altered both unsystematically. George had asked them about this in the first few minutes, and had discussed briefly with Luke and Danny and then with Rebecca's group how they planned to handle it:

George: Now then Luke

Luke: yeh?

George: are you going to keep your ramp at the same height or are you changing it?

Luke: no - we're just keeping a 3 centimetres high ramp here and then we're doing a 6 centimetre high ramp

George: ye-e-h. so you're changing the height of the ramp?

Luke

& Danny: yeh/yeh. and then we'll. then we're going to do 12 and then when we've done - we'll have done 3, 6, and 12 - then we'll put another one on we'll do 3, 6, 12 (demonstrates how they will measure run with each weight at each height)

George: that's going to take you a long time isn't it? You'll have to work very fast if you do that

Luke
& Danny: yes/yes

(George moves across to Rebecca, Jenny and Elaine)

George: now then what are you doing?

Rebecca: we're going to find out we're going to put how much weight we put in () and how many layers of cubes we've got underneath and how far it goes ((all said breathlessly quickly))

George: fine - er - what are you changing each time - what are you going to change?/

Rebecca
Jenny
Elaine: (height)/weights (.. and..) each time
(Audiotape 1/5/84)

Dorothy and Debbie had made little progress when he visited them half way through the lesson. They were still varying both height and weight unsystematically. After unsuccessfully probing their ideas and offering an analogy he resorted to direction:

Dorothy
& Debbie: it's going/

George: what's making it go.. either the height of the ramp or the weight?

Debbie: it's the weight

Dorothy: it's the height of the ramp

George: but you're also raising the height of the ramp

Debbie: it's the height of the ramp

George: but you're also putting more weight on it

Dorothy
& Debbie: (silence)

George: do you KNOW ?...DO you know? .. you don't know ((responding to their looks, not to any reply)) I see. so what can you do to find out. which is it. that's causing it to go further?

Debbie: Well

George: pardon ((then repeats or interprets murmur by girls)) put less weight on it - and still raise the height of the ramp?

Debbie: raise the ramp down

George: raise the ramp down? lower it

Dorothy: put less weight on it and raise the ramp down and put more weight on it and put the ramp up

George: it's a bit like my shower at home - if it gets too hot sometimes I turn down the hot water and turn on the cold. and that means I don't know which I've done right - whether or not I've made it go cooler by turning the cold down or turning the hot up. I should do one or the other shouldn't I?

Dorothy
& Debbie: yes

George: and what should you do then?

Dorothy
& Debbie: (a pause) errhm (laughter)

George: I'd keep the ramp the same and change the weights in there - O.K.?

Dorothy: yes
(Audiotape 1/5/84)

After he left them Dorothy and Deborah told me they were "starting again". They drew a new table for their results and began rolling their vehicle down the ramp, changing only the weight this time, but not working very accurately. They appeared to be following George's directions but I could not tell whether their approach to investigating variables was affected by his intervention. I had watched to see if George's interventions

varied with different groups of pupils. He had followed his stated intentions of only intervening where he saw a need. His responses to those needs appeared to be influenced by his perceptions of the pupils concerned. For instance the aimless behaviour of two boys, William and Jimmy, and his experience of the problems they generally had, led him to spend a long time organising their investigation, prompting them, and recording their measurements to ensure them some success. Luke and Danny meanwhile had amassed a wealth of results with little need of help. A different sort of intervention was needed later however to help them see a pattern in their results, as George explained to me at our interview the next day:

so it was only when I said "you must now get all of your 3 centimetre readings and put them together" ..(referring to the height of the ramp)) they hadn't put them together .. they'd left them scattered around/ and there were quite clear progressions .. the gradual .. it wasn't big .. but it was absolutely a pattern .. the difference with 100 grams, 200 grams, 500 grams, quite clear what the pattern. but they hadn't pulled out all the measurements and stuck them down on their paper - and said "yeh this is it" they're very tentative
(Interview 2/5/84)

Luke and Danny's caution over interpreting their results had been evident when I talked with them after the lesson ended, and when they declined to comment in the class plenary session just before that. George had halted the activities at 11.45 am and gathered the children together for ten minutes or so discussion of their findings. He asked them to report their results and to relate their interpretation to their original predictions and hypotheses. The results varied, and led to some re-examination

of the predictions they had made at the start of the lesson.

Mark remarked that his results now led him to think Steven was right, while Steven commented that "we learned that my theory was right up to an hundred grams and then . it. went .. it went fa.further as we put more weight on it"

A few children had reported back and Duncan was attempting an explanation relating weight and speed, noting the complications caused by the back wheels lifting or being locked, when the bell went. George hurriedly announced that they would write up the investigation later that day, and the next morning, and see if they could make more sense of it then.

9.5 George's Evaluations of the Lesson and Follow Up Work

George was critical of his handling of that plenary session in his written comment in his journal, and when we talked about the lesson at our interview on 2 May. Stimulated further by replay of the video recording, he commented how he had hurried it, with reference to Mark and Steven's reports. He recalled how the two boys had begun the lesson with opposite hypotheses and noted how they seemed to have exchanged viewpoints in the light of their results. Originally Mark had predicted that adding weights would cause cars to run further "because you need more power", whereas Steven had suggested that extra weights would "push the wheels down and it'll hardly move." At the end of the lesson they each briefly explained how their results now led them to revise their

views. As he watched this being replayed George commented

I should have followed that up you know .. I've not given Steven time to think/ I should have given them a lot more time/ I rushed through it too much to get quite a few pupils contributing and it confused matters really/ I'm not keen on what I've seen of the round off (Interview 2/5/84)

Although he was unhappy with his handling of that last part of the lesson George was pleased with the children's response to the task, as he noted in a brief journal entry and elaborated in our conversations. At the start of our interview on 2 May he commented on the class discussion he had held that morning and on the children's writing up of their investigations. He had the discussion to explore their explanations. From their answers and questions he had inferred that most pupils could relate the activity to ideas about energy and raising and dropping objects, drawing on some work done the previous year on flight. He said they had applied these ideas to their explanations of distances rolled by their vehicles more appropriately and effectively than he would have expected. Although their subsequent writing showed more confusion and less evidence of understanding he remained impressed with their grasp of ideas.

George had based his initial evaluations on his recall of the lesson of 1 May, the feedback in the class discussion on 2 May, and his first inspection of the pupils' writing. Over the next few days he looked more thoroughly at his recall of the pupils' performance in the lesson and at their written work. Some examples of work are included in figures 9.2, 9.3 and 9.4 to

illustrate the range of results, but the emphasis in this account is on George's thinking rather than that of the pupils'.

George's first impressions had been of pupils' success in understanding the activity, getting results and interpreting patterns in those. He decided to assess their work more systematically. Using the categories and sources of evidence summarised in Table 9.2, he graded each pupils work a,b, or c for very good, good, or poor.

TABLE 9.2 GEORGE'S ASSESSMENT SCHEME FOR PUPILS' WORK OF 1 MAY

Category	Source of evidence
1. Skill and approach to practical	recall of his observations in the lesson of 1 May
2. Recording & tabulating	written work
3. Use of results to draw a conclusion	written work
4. Eventual control of variables	as observed by end of lesson on 1 May

Ivor

Do Heavy Lorries Roll
Further than light
lorries?

*

Flats	1st test	2nd test	3rd test
50g 6 flats	107cm	109cm	100cm
100g 6 flats	120cm	119cm	132cm
200g 6 flats	123cm	110cm	108cm
300g 6 flats	102cm	93cm	101cm
500g 6 flats	153cm	162cm	157cm

First we got some weights then a car we made a ramp we put the weights on the car and let the car run down the ramp and saw how far it went with different weights. I found out that more weight made it go faster.

Figure 9.2 Pupil's work (2/5/84 - Ivor)

*n.b. Pupils were using 'flats' and 'cubes' from maths apparatus to raise the ramp. In this case 6 flats by each test means the height stayed the same.

Do Heavy Lorries Roll further than light lorries?

What we did was we got a pick up truck a metre stick and some subes and a board and we put a sube under the board and we put a 10g weight in to the truck and we let the truck go down the ramp and our Results were then after

subes weight that we put a 10g weight on the lorry and our Results

1st test 139
2nd test 138
3rd test 138

subes weight I thought it would go about 60cm we were sure that the Results on the next test the results were going to be higher then on the last test we put a flag on the lorry and it would

1st test 139
2nd test 138
3rd test 138

Results were then after

1st test 139
2nd test 138
3rd test 138

not move it would not go because all the weight was on the back wheels and the front wheels were not on the ground and the results when we did it were 11cm 5cm and 5cm then we did it with no gram and the results were

subes weight

1st test 139
2nd test 138
3rd test 138

Results 138 cm

subes weight 138 cm

Do Heavy Lorries roll
further than light
lorries?

We Yesterday we wanted to find out which went
the furthest the heavy lorry or the light
lorry so we got a board and put ~~it~~ it up against
the pipe and got some weights and a lorry and put
100 grams in the back of the lorry and put it at the
top of the ramp and let it go and it went
2 meters 60 cm and the furthest it went with
200 grams was 2 meters and 61 cm and with ^{three} hundred
grams it went 2m 74 cm and the least it went was
3m 30 cm with 600 grams and after Mr P.
asked us questions and I found that the more
weight the further it goes the lighter weight
the smaller it goes.

100g	} 2m 60cm 2m 60cm 2m 60cm	400g	} 2m 98cm 2m 97cm 3m 6cm
200g	} 2m 61cm 2m 30cm 2m 37cm	500g	} 3m 23cm 3m 18cm 3m 21cm
300g	} 2m 74cm 2m 58cm		

Figure 9.4 Pupil's work (2/5/84 - Michael)

Michael

This was the only occasion when I observed George lay out such a detailed marking scheme although he often made explicit the criteria by which he assessed progress. In the term's project the reducing emphasis on written products meant those assessments were often related to processes and inferred from observations and conversations. In this case he gave equal weight to recalled observation and to analysis of written records. George explained this scheme to me when I was in the classroom on 4 May. I avoided making any comments on the work or his assessment. It was interesting to hear his own elaboration and qualification of his judgments on my next visit on 8 May. By then he had tried out the activity again at home with his son. He had been surprised to find that increasing the weights often reduced the distance rolled by many toy cars. George reported that this had influenced him when he re-examined the pupils' writing referring to his category 3. Having now looked at all the writing he judged that many children had tended to form some conclusion not really based on their results, although there were exceptions, including Rebecca who was rightly cautious over the findings of her group. Their car had rolled similar distances as they increased the load from 10g to 100g and Rebecca concluded her writing up with "I learnt that how many weights you put into the car it will still go about the same distance".

Rebecca and her partners had met some problems from the erratic behaviour of their vehicle, and their own inconsistent measurement. George discussed the former with them in the lesson

but did not pick up the latter until he saw it on videotape the following day. Then he was surprised. In his comments on that he moved from immediate evaluations to identify a more general dilemma over how best to teach skills. He remarked how the videorecord made it clear to him that he had not mentioned measurement, and this should not have been left to chance even though he wanted pupils to do the investigation in their own way.

He remarked that measurement was a basic skill which maybe he should have taught, but then added "its a bit of a dilemma to know whether you should teach specific skills." This dilemma was to lead to a more general examination of his beliefs later in the term, which will be traced in Chapters 10 and 11.

9.6 George's Plans for 4 May and After

After reviewing the lesson of 1 May George moved spontaneously to mull over his plans. He was thinking aloud and as our interview proceeded on 2 May he produced an account that illustrated the ingredients and the processes of that thought.

He began by saying "I'm not quite sure where I'm going to go from here/ with the term being so bitty." He had commented earlier how interruptions during the term constrained his planning; he repeated later in the interview that this would influence his decisions about how to distribute activities and when to start them. He had to decide now whether it was time to draw another activity from this store of possibilities for

promoting the kind of learning he had in mind. After some reflection he came to a decision to set a new task which would link in with the downhill work already done.

George: .. difficult to decide just what to do whether or not to just press on using these commercial cars .. in various ways ... (not sure) that's going to be very fruitful in getting people to where ... I have to go

R: yeh?

George: or .. erhm .. giving them more the .. an open-ended brief .. or not an open-ended brief .. a brief to design a vehicle of some kind

R: what .. based on that .. structure that they've seen? ((see figure 9.5 below))

George: based on the structure .. yeh get them to either .. do something which will travel in a straightish line off a ramp/. going downhill .. or go greater distance off a ramp/ I'm .. I'm tempted to go along that line .. now .. and that will link in nicely with what we've done (Interview 2/5/84)

George briefly reviewed what he felt pupils had learnt from the lessons before Easter and on 1 May that could now be applied in designing vehicles to run fast or straight off a ramp, possibly leading to class competitions. He talked about how he envisaged the lessons, contrasting them with the two more directed ones he had already introduced.

George: because then .. what I'd anticipate them doing .. though whether they'd do it is another matter .. is first of all designing the vehicle .. just giving them materials for it .. then using that vehicle and testing it .. to find its optimum performance

R: yeh

George: thats it .. the tilt of the ramp .. most competitions like that specify ramp height .. but I think it would be more fruitful if they could alter the ramp .. and erhm in that way they could use all the ideas they've been using in the last couple of lessons but in an applied science .. way where there won't be any need to record .. they make one or two and I may ask them to from time to time .. but the main thrust of the work will be in actually producing that artefact that will go .. far .. further or straighter

R: yeh .. so your lessons will be a combination of making and testing?

George: yeh .. but it will be .. totally their own direction
(Interview 2/5/84)

George explained how he anticipated pupils would move back and forth between making and testing as they needed in a flow of activity such as he had envisaged for the term. The lesson on 1 May and that at the end of the previous term had been "the precursors of ... of this more interesting ... far more open-ended challenge." He confirmed his image of the term as a series of such extended activities with the occasional interjected lesson. When he mentioned his plans for later activities it was clear they were still flexible but becoming firmer as the time to implement them got nearer. He remarked that 'toys' were still in his mind, 'bikes' would be introduced sometime perhaps, and he was still thinking of using a playground as a source for science. He did not intend to take the 'downhill' work with cars much further,

because after that when I think I'll be going downhill I want to go uphill .. and I think I may get someone to try

the electrical (motor) but I've got more in mind rubber band tanks (Interview 2/5/84)

As well as voicing his planning thoughts George commented upon them. He remarked that he was pleased with the way the plan for the next activity had worked out, and happier that he had stood back a little and thought about it some more "rather than plug on with looking at more and more elaborations on the present theme." This interview provided insights into the personal reflection and the movement among means and ends and beliefs that occurred in the process of planning. Several times George referred to his belief that science learning should be applied in real problems, noting at one point that it was a part of his basic philosophy. He referred to this, and linked it with pupils' motivation in his final comments on the plans he had just made for the next activity,

when I think the idea I'm really onto now .. is .. not so much an elaboration on a theme .. its a real thing that they'd want to do .. which will actually use all the skills that they've (met earlier)/ certainly I think .. that thats what they'd think ..erhm ... they'd want to do something with their new knowledge .. and certainly not many of us would find the idea of a competition easy to resist .. although its not going to be a heavy competition (Interview 2/5/84)

9.7 George's Setting of the Task on 4 May

Before the lesson on the morning of 4 May George told me he planned to set the task by referring to that competition and demonstrating a technique for constructing a rigid chassis (figure 9.5).

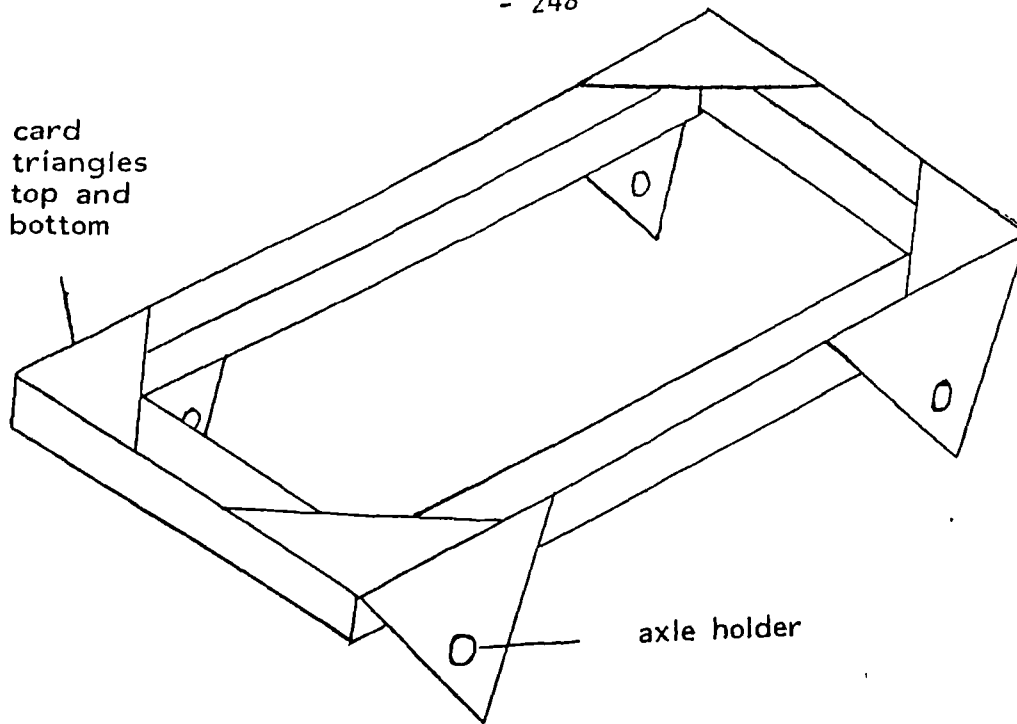

Figure 9.5 Basic chassis design used in constructing vehicles
(see Williams and Jinks, 1985)

He had learned the technique from a teacher at a primary science display and before Easter a few pupils, including Luke and Danny, had tried it. Now he was going to use Luke's model to illustrate it to the rest of the class. He intended to stagger the start of the lesson, rather than begin all the children on construction at once.

After play the class was told that there would be a new activity of making model cars to begin today as well as some earlier writing on swallows to complete. Then George referred to the board where he had prepared a summary of the eventual competition. He noted that there were several options (figure 9.6). The models could be judged by how far or how straight they ran, or by the quality of their construction.

After mentioning the alternative categories for designing a car he showed Luke's model to the class. He drew attention to the elements used in making a chassis, bearings, axles and wheels as he recommended the technique. There was a quickfire question and answer session in which he stressed accuracy, and he suggested dimensions of 15 by 10 centimetres for the chassis.

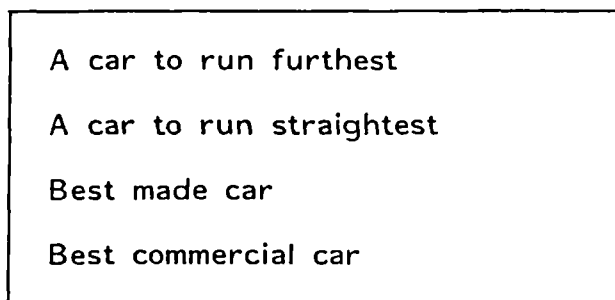

Figure 9.6 Board diagram summarising options for final competition

9.8 The Action on 4 May

Twenty minutes into the lesson most children were still writing about swallows and George mentioned to me that he found it tricky to know whether to interrupt. He wondered if it would be less distracting for those who were writing to have them all begin the practical activity together after all. His intention to start the children on the task in stages had seemed best to avoid congestion and allow faster workers to be a model for others. However forty minutes into the lesson he told them they could decide for themselves when to start, stressing that sawing was to be done at the craft benches and sticking and testing at their own desks. All our target pupils except Rebecca put their writing into their files for later completion and began making vehicles. The uncertainty over his decision was resolved by turning it over to the pupils.

For the rest of the afternoon, and through two other long sessions on 8 and 11 May, I observed how George's provision of a "far more open-ended challenge" and of a more extended opportunity for the children to develop ideas and skills worked out in practice. The skills required and the pupils' mediation of the task complicated the realisation of the image he had for the activity. Those particular complications not only affected the pupils' achievements and his interactions with them but led George to re-examine some of his own assumptions about teaching.

In my fieldnotes and the audiotapes of George's contacts with pupils the emphasis was on the technique, materials, measurement and other details of construction, especially in the early stages of the work. There were only passing explorations of opportunities to learn about structures and friction. George spent most of his time discussing progress and problems in making the vehicle. He was able to praise and prompt the ideas of some children such as Luke and Danny who were succeeding and showing the germ of testable ideas, for example about the best size of wheel to use. Dorothy received praise for her ideas and he remarked to me on how her progress today contrasted with her experience in her previous class, perhaps because of the stress there on neatness and allied values which she did not enshrine. Her performance in the lessons I observed was closely related to her interest in the task set; her persistence when engrossed was often evident when George had set the class clearing up and she worked on into playtime or at the end of the day, as on 4 May. On the other hand Rebecca was often slow to start, as she was on 4 May, and her group made disappointing progress, requiring lots of help from George and encouragement to persist and develop their own ideas.

9.9 The Action on 8 May

On 8 May the class had one hour before and one after lunch on this task. At lunchtime George reported that he was pleased on the whole with their progress. Their initiative and the use they

made of the extended time he provided in the afternoon to develop their ideas led him to remark "I think I'll retire now, they don't seem to need me much".

Despite his overall judgement that the working atmosphere and progress were good he commented how he was becoming more directive to ensure results. As several pupils had difficulties making washers he began the afternoon with a class demonstration of the technique. Throughout the day signs of resource constraints had appeared - wheels and axles were in demand. Although George intervened more with direct help to speed up work he had time to share lots of jokes with pupils and check on their welfare.

At the end of the session however he mentioned to me that there was a danger that the pupils might just expand their work to fill the available time and pressure was needed if some more organised testing of the vehicles was to occur. In his mind the model making was clearly still also a means for promoting the pupils' learning of scientific skills.

9.10 The Action on 11 May

The final session on this activity was held on the afternoon of 11 May. It began around 1.15 pm with a reminder from George of the need to test their vehicles now, as he asked them to recall

the competition and to remember "What are you actually trying to achieve with your car?" For the children, however, it seemed the techniques and appearance of the product were uppermost and they concentrated on the detail of their manufacture.

The lesson began with a calm, measured atmosphere as the class responded to George's request to complete the cars and other unfinished work quietly. My notes and the audiotaped interactions conveyed the increasing frustration of George and his pupils over the afternoon. The source of this deterioration lay, in George's analysis, in pupils' over-concern with decoration and detail. He pointed this out to me at 1.45 pm.

interesting in a way . and frustrating . they were just making the vehicle . just making it work . now they've become excessively pernickety they are changing without reason
(Audiotape 11/5/84)

Luke had already had some failures while cutting washers which had led him to hold his head and call out "it's all going wrong". His partner, Danny, was now struggling as he refitted wheels and commented "Mr Packham, its difficult". Ten minutes later George had to repeat an instruction to Dorothy not to roll her model round till the paint dried. This was her second version, as an earlier one had collapsed after she had painted it too liberally. Although George had showed the class that as a warning, and repeated the advice continually, many pupils painted moving parts and reduced the performance of their vehicles.

After play George gave the class a deadline to get ready for a trial run of their vehicles. Rebecca's group was only belatedly having success cutting the larger wheels they wanted. They needed help from George and an intensive burst of work at the end to complete their model in time to run it with the others at 3.20 pm.

When it came to time for finishing George had to reprimand the class for tidying up badly, and hurry them into sitting round for the demonstration of the vehicles. However he was quickly able to establish a relaxed and positive atmosphere for the short competition. There was lots of enthusiasm and fun as vehicles were shown, given names, and run down a ramp. After a trial run metre rulers were laid across the floor and one of the boys, Peter, chose to record results as George measured how far each vehicle ran. Some pupils predicted how theirs would perform, Simon and Mark saying they thought theirs would be best. After assessing how far and how straight vehicles ran some informal judging was done of the designs and constructions and pupils voted on the originality and looks. A few pupils volunteered explanations of their performance and determined to improve on them. Luke turned to Danny and said "I'm going to make ours go better". There had been limited testing and modification of the models, and a little incidental teaching about structures and friction. Although this was a very short finale to three long lessons George had decided it was now time for a change of direction, as he told me after the lesson.

This decision was not simply an immediate response to the frustrations of the lesson; it also reflected his earlier diagnosis of the class as one which required variety and his underlying plan to draw on several activities from his repertoire. At lunchtime he had been considering the next activity as he previewed some schools TV programmes he might use.

9.11 Discussion of the Analysis of George's Thinking and Primary Science Issues

The account has followed the downhill activity from George's plans, through the realisation of the lessons, to the pupils' products and his assessments. A variety of data has been cited to portray the action and related thinking. Some features of the situation have been seen to influence the progress of lessons and George's decisions (eg resource constraints, and interruptions which he characterised as the "bittiness of the term").

Layers of planning were represented, from long term goals and strategies to immediate plans for lessons. Movement between layers was evident. The conversation of 2 May conveyed the reflective, personal nature of this planning process as it incorporated other aspects of thinking, such as George's views about pupils' learning and science which he referred to in terms of their application of knowledge or "applied science". Planning thoughts centred on activities which had been drawn from George's

repertoire, but they had to be adapted to the purpose and the circumstances. The activities in this unit were intended to promote particular skills and attitudes and George evaluated their success accordingly. These were to become common activities in primary science and technology but at this time George had limited experience of using them for his purposes. Their realisation in practice gave him some insights which could enrich his repertoire for future use. For instance the complications in rolling loaded vehicles or constructing moving models had been experienced in the classroom and considered in his evaluations.

George appeared to see activities not in isolation but in relation to others which had already been used, or which might be used later. The flow of activity over several lessons and within each was envisaged when they were translated into tasks. George's images of lessons included the task setting, the timing of that flow of activity, and anticipated the roles that he would play and the responses of pupils. There were some indications that pupils interpreted tasks in their own ways which did not always match his intentions when he set them for the class and interacted with individuals, for instance in their approach to investigations and variables. His classroom interactions followed his intentions and were to some extent differentiated to match individual needs. He recognised that pupils mediate tasks, for example expecting that in building vehicles to test they would be most concerned with the constructional techniques. By

11 May he had discovered that concern over decoration and problems with craft skills had become dominant. Pupils' responses were the main cues for decisions he made or deferred in lessons. Minor decisions included modifying the timing to give them more opportunity to develop ideas, or changing from his plan to stagger the start of a lesson. The timing of the larger decision to shift to a new activity after 11 May was influenced by the children's performance as they diverted the task from investigation to decoration, but made with reference to less immediate aspects of his thinking.

Thinking in lessons involved fine tuning of plans, and interactions, but was not confined to that. It included some more general reflections and assessments of pupils. This thinking could be extended after a lesson and the presence of an audience or a stimulus to recall seemed to encourage its expression and elaboration. George's assessment of pupils' learning in the lesson of 1 May was developed to probe his first impressions, comparing different sources of evidence. The criteria he used in this process, and his objectives for the lessons, gave further insights into his underlying framework for primary science. For example the control of variables, checking of measurements and interpretation of results were identified. His emphasis on those process skills was not yet common in primary schools, as a summary of APU findings pointed out (Harlen, 1983b).

George also gave some insights into his views on children's learning of scientific ideas on 2 May. Alongside the earlier discussion in the lesson of 1 May these suggested some aspects to consider in examining his theories on conceptual learning: the role of experience and previous learning when, for instance, George commented on how pupils related earlier work on flight and falling to the rolling of loaded cars; pupils' predictions and explanations based on their alternative ideas, illustrated in his comments on Steven and Mark's hypotheses; testing and application of their ideas, for which he had provided some opportunity. At this stage these have to be tentative interpretations on the basis of such limited evidence, but more detailed analysis of explicit statements was possible later in this study. There were some difficult concepts associated with the activities and a sophisticated grasp of them, or a consistent use of terms, would have been surprising among 10 year olds. Research on children's conceptions which could inform teaching was emerging (eg Osborne, Schollum, Hill, 1981) but was not yet readily available to teachers such as George. A related issue in science education which is relevant to the analysis here is the balancing of pupil activity and class discussion. George had expressed his concern over his handling of the plenary session of 1 May, judging that he had provided too little time and opportunity for children to express their own ideas. That judgement had been stimulated by seeing a video record of the lesson. So had his discussion of Rebecca's measurement in which he moved from commenting on one concrete instance to drawing a more general conclusion and

announcing a dilemma over skill learning. This will be elaborated in the next chapter as the 'Downhill' journey gives way to an 'Uphill Struggle'.

CHAPTER 10 UPHILL STRUGGLES

10.1 Introduction and Overview

On 14 May the activity shifted from rolling vehicles downhill to making them go uphill. George's decision that it was time for a change of direction has been introduced in the last chapter. In anticipation he had been reviewing his plans and resources, including television programmes from a Junior Craft, Design and Technology series (BBC 1982) from which he selected the one entitled 'Uphill' in which pupils could be seen making powered model vehicles to show the class. The Uphill theme was continued in lessons over the two weeks leading up to half term and for one long lesson after the holiday. George began with a simple model to switch the emphasis from construction to testing at the start of this new unit.

First the children used cotton-reels to make simple moving toys, referred to as bobbin tanks, and devised their own questions to investigate. On 15 May they jotted down their questions and plans for tests, and the afternoon of 18 May was devoted to implementing these. I collected copies of their first jottings and their writing up, which was done between 18 and 25 May. The example by Luke, one of the target pupils, in figure 10.1 illustrates this first stage of the uphill journey.

What we did with our bobbin tank

To make our bobbin tank we got a stick three rubber bands a wax washer and a bobbin. We doubled the rubber band and stuck it through the bobbin then we got a little stick put it through the rubber band then pulled the rubber band from the other side. Then we got a paper clip threaded it on the rubber band with the stick then bent the paper clip and put it down one of the holes at the side then got the wax washer and threaded it on the rubber band then got a longer stick and put it through the rubber band then put it through again to make it tighter. Then we got to the other two rubber bands and put them on both ends of the bobbin then we wound the tank up and let it go.

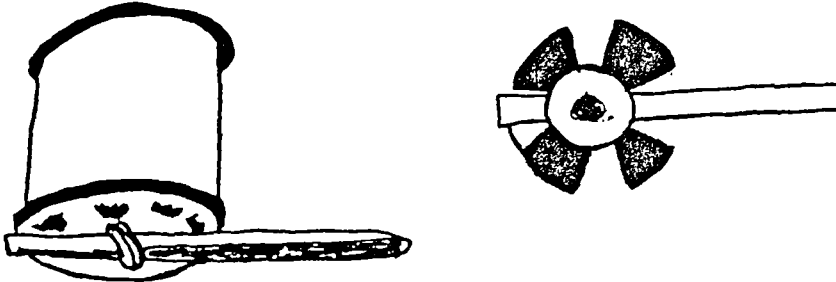

We trying to find how good it went up rough and smooth boards and how steep it can climb with a rough board. We got a board and put it up on some unit blocks then wound our tank up ten times and turned it to go up the slope with a rough and smooth ramp then we got some sand paper and put it on the slope and kept on making the slope steeper and steeper and found how steep it could climb.

Results

10 winds - rough ramp	10 units high
1st 50 seconds)	
2nd 53 seconds)	median 53 seconds
3rd 59 seconds)	

When we had the sand paper ramp it stopped at 21 cm high with no tyres and with tyres on it stopped at 26 cm high. We found that the tyres did help grip. We did more tests on the rough and smooth ramps but we found it was too hard for the tank.

Fig 10.1 Luke and Danny's early work with bobbin tanks
(typed from their original to fit)

Following that simpler task George set the children to plan and build a small vehicle which would move uphill. The construction of their downhill models provided a starting point and the bobbin tanks, and other power sources illustrated on the Uphill TV programme, gave them some ideas. There were two lessons on this before half term, on 24 and 25 May, and the activity continued after the holiday in an extended lesson on 7 June. The original goal of running the models uphill and comparing them was not pursued when difficulties arose with the construction and with fitting power sources. The title 'Uphill Struggles' refers to the pupils difficulties and George's frustrations. These accumulated and led him finally to set aside the task for the time being and shift to the new activity described in Chapter 11. Table 10.1 outlines the sequence of the action and the data.

My own notes, and audiorecords made in lessons, are the basis for the account in this chapter. These were complemented by collecting copies of the pupils' work and George's notes. Some videotaping of activities on 18 May and 7 June assisted the checking of observations and transcribing of conversations. The data included many records of George's thinking, which he reported regularly over the weeks in comments and conversations at school, and more systematically at an interview over half term, on 27 May. A transcript of that interview is in Appendix 3.

TABLE 10.1 OUTLINE OF THE ACTION AND DATA IN 'UPHILL STRUGGLES'

<u>Date</u>	<u>Action and Comment</u>	<u>Data</u>
14 May	Lesson making bobbin tanks Pupils see 'Uphill' TV programme	Fieldnotes Audiotape of teacher TV programme notes
15 May	Pupils given 10 mins to jot down ideas for investigations with their tanks	Note of teacher's comment. Pupils' jotters
18 May	Lesson testing bobbin tanks	Fieldnotes Audiotape of teacher Videotape
18-25 May	Pupils write up their tests	Pupils' work
24 May	Lesson building and powering vehicles to go uphill Pupils see 'Uphill' TV programme again	Fieldnotes Audiotape of teacher
25 May	Second lesson building and powering vehicles	Fieldnotes Audiotape of teacher
27 May	Half term week Interview with teacher	Audiotape
7 June	Final lesson building and powering vehicles	Fieldnotes Audiotape Videotape
14 May-7June	Teacher's Plans and Evaluations in Journal	

10.2 George's Planning

George's reports of his planning for this unit revealed the complexity of the process as it occurred. It involved movement among layers of planning, with reference to theories and to thinking in lessons. The account here reflects that movement while analysing the separate ingredients in his planning thoughts.

Chapter 8 described how George approached the summer term with a selection of potential activities from his repertoire. Those included simple toys, models and vehicles. When the topic was launched only the downhill activity had been sharply focussed in his mind. While that was underway he was also thinking about the later stages. For example he had reminded me on 2 May that he was still planning to introduce work on bicycles. Within that longer term planning he was focussing his plans for this, the uphill activity, and coming to decisions about what to introduce next and about how and when to start it. The immediate decision to switch at this point seemed to have been stimulated by the problems in the lesson on 11 May, and his evaluation that the potential of the downhill work was exhausted. The chosen task was intended to produce success for pupils and to emphasise testing rather than the construction which had become somewhat frustrating.

At the end of the lesson on 11 May George had commented to me that it was time for a change of direction, as reported in

Chapter 9: He developed this comment at lunchtime on 14 May, just before the next task was introduced.

I don't think I'll press on any further because this is a class that gets bored very quickly ...

if I pressed on much further with those cars and that idea of going down the ramp it would be old hat . and dull. I don't think it would serve many purposes . so I want to move on . I want to move on into powered things . and the simplest powered thing that they can all succeed . is those tanks . and then after that we can then see where we can go with that car idea . see if they can develop it a bit more to make it run like a proper vehicle . and going uphill
(Conversation 14/5/84)

A further ingredient was incorporated into his thinking by a schools TV series on Junior Craft, Design and Technology (BBC, 1982) which he had previewed during my visits with video equipment. In the end it would only be used as an additional stimulus to pupils' ideas, but at the planning stage it provided insights into several features of his thinking. The extracts from the programme notes in figure 10.2 summarise the approach of the series and the content of the programme he eventually selected. His reflections on this are reported in this chapter. As I drove him home after the lesson on Friday 11 May George had mulled over which bits of the programme to use. He talked also about the possibility of introducing cotton reel tanks, but noted that he needed to think this over further at the weekend.

By Monday 14th he had firmed up his immediate plans for the cotton-reel activity but was still considering how to draw upon the TV programme to enhance the subsequent investigations into powered vehicles. He had not forgotten longer term plans for

UP AND DOWN THE HILL.

The purpose of this series is to help primary school teachers to introduce their pupils to the essentials of Craft, Design and Technology through topic work (based in this instance on wheeled transport)

Craft, Design and Technology is an umbrella title which covers three closely inter-related areas of pupil activity

Craft work is the creative use of materials and the safe use of appropriate tools. The range of materials used by primary school pupils can be extended to include wood, metal and plastics - though not necessarily in any specialised sense

Decision-making and problem-solving are important activities for all pupils. These programmes will help pupils develop and practice these skills by applying the Linear Design Process

The emphasis will vary from time to time, but basically the process consists of

- i) Understanding the PROBLEM and what is involved in it. This may require some research into any new knowledge, skills, or techniques which will be needed to reach a solution
- ii) The PLANNING stage, considering the possible solutions and deciding which one should be adopted
- iii) MAKING a real solution, whether it is a 3D object or a detailed plan of action
- iv) TESTING and evaluating the solution, followed by a review to find out if any further improvements can be made

As a shorthand these stages are referred to in the programmes as PROBLEM, PLANNING, MAKING and TESTING

These stages need to be carefully introduced and practised at a level appropriate to each pupil's ability and experience.

Each programme in the series sets one or more problems, the solutions of which should take children through various craft skills and techniques, ideas of how to carry out effective designing, and an understanding of some of the scientific and technological principles involved. The programmes contain three main elements. Jan, a mime artist, finds herself in situations which raise the problems; children, filmed in the classroom and elsewhere, take us through some solutions to these problems, and through the use of close-ups and other film techniques we look at the technology related to the problems and the skills needed to solve them.

- Programmes**
- 1 Downhill
 - 2 Building a Vehicle
 - 3 Uphill
 - 4 Wheels and Gears
 - 5 The Use of the Land

PROGRAMME 3

UPHILL

TOPICS

- i) A survey of different types of vehicle with different types of motive power
- ii) Making a powered vehicle using rubber bands, clockwork or electric motors
- iii) Transmission, connecting the power source to the wheels
- iv) Testing the models. The criteria of success

BEFORE THE PROGRAMME

Pupil preparation

- i) Pupils should have an understanding of simple electrical circuitry. This need only involve the connecting of a battery to a motor or light
- ii) Pupils should be able to use a screwdriver, pliers, and wire strippers

Teacher preparation

The following may be useful: rubber bands, small clockwork and electric motors, batteries, short lengths of insulated wire, small pulleys and shafts such as Meccano or Fischertechnik, miniature bulbs and bulb holders, wooden or softboard blocks for mounting circuits

Vocabulary

Gravity, power, pulley, electrical current, battery contact

THE PROGRAMME

Jan demonstrates the difficulty of pulling a heavy cart uphill, against the force of gravity. The concept of an alternative source of power to our own muscles is introduced, and we see several vehicles with different power sources, such as a horse and cart, a milk float, a lorry and a railway train. A group of children classify vehicles according to their power source - the choice of which is seen as part of the design process

Discuss the appropriateness of type of power source to a vehicle's function. Points to consider include: how far the vehicle is to travel, how fast it should move, what load it is to carry, what type of terrain it is to cover, does it need to stop and start a lot. The answers to this sort of question lead to the explanation of such things as why a milk float has an electric motor or why we don't use horses and carts to supply supermarkets.

A problem is now posed - to build a small powered vehicle, capable of carrying a load uphill. The four stages of design are recapitulated, and we see children solving the problem, using clockwork and electric motors, and rubber bands to power their vehicles. Again we look in detail at some of the craft skills used by the children

Figure 10.2 Extracts from TV programme notes

other activities. When we met over lunchtime he began by remarking that he still intended to introduce work on bicycles for which he had materials available. However the main topic over lunch as he reviewed the TV programme was how to use it in the medium term plan for designing powered vehicles. We will follow his thoughts on that and then turn to his lesson plans.

He had reservations about the emphasis on the design process in the TV series and chose the "Uphill" programme because of this as well as the relevance of the title.

I think I prefer that much better because there's far less emphasis on this design side of things/

it's very .. not laboured but/ . very measured approach to it and it would seem to me that with this class it would be inappropriate .. they wouldn't know what I was talking about for a start . designing/

to get them to draw it after it would be sensible . cause then it would be an exercise in scale .. and an exercise in looking .. so I'll get them to do that some time this week because then I can get them to do the process in reverse . to design a model and make it (Conversation 14/5/84)

As he watched the programme George reflected on why and when he might show it.

In some ways it might be better not to show it today we haven't really got the time . but I think it . the . a lot of the stuff would be logically ideal if we used it as a kind of incentive . more than a . an actual instruction

I think in fact if they started making it on Thursday they'll still obviously be .. very involved in it by .. Friday .. yes by Friday .. and next week .. there will be another time to show exactly the same thing .. I often think that sort of thing goes in better the second time anyway .. and a lot of lessons those children will learn which I think were nicely put over in the programme . even . would be the sort of problems they would begin to be encountering (Conversation 14/5/84)

George's use of the TV programme can be seen in his summary of the lesson plans which he wrote and later gave to me in his journal. He summed up the plan for the first lesson that afternoon as follows.

Monday 14 May

Short session on construction of tanks

Followed by TV film about Uphill.

I plan to ask children to write down their ideas about what investigations they want to do. Ask them to specify clearly their aims and a few of the pieces of equipment and approach.

My aim here is:

- a. To make sure use of tanks is purposeful
- b. To emphasise the children's own responsibility for planning and executing their work

(George's summary of his plan in his journal)

The next day, Tuesday 15 May, the children would have to complete the planning stage of their investigations in their jotters.

These were to be put into practice on Friday 18 May in a very open-ended afternoon, when George planned that they should get on with answering their own questions and move straight into recording. If time allowed they could start on the basic chassis for their powered vehicles. His plan for the next two lessons was summarised in the following written outlines.

Thursday 24 May

11.20 am view the uphill programme for second time pausing more often and discussing features of the programme in more detail. Discuss weight of vehicles as a major factor also strength of chassis

Set task

Design your own uphill vehicle to climb a 20° slope 1m long under its own power

Stage 1

Design. Draw diagrams either full size or scale showing position of wheels and shape of chassis. Specify power to be used.

I expect the design stage to take 1 hour and after discussing design with me I will allow children to go straight into construction.

I expect to give bulk of pm to this activity probably stopping about 3.20 to clear up 3.30 for story.

Thursday 7 June

Time 1.15 - 3.45

Aims Finish 'first draft' of the cars

Test

Begin modifications

Need to improve speed of work and focus of their activity so to help this I will ask children not actually involved in construction or testing to have alternative work available.

When cars are finished I will ask children to design own test and experiments for them along lines of tank experiment.

Am thinking about focussing next stage of making a toy to making a rubber powered toy e.g. mangonel, improved tank, stationary engine, roll and return vehicle

(George's plans summarised in his journal)

At the start of this unit George had formed an image of how the activity would flow through the time available, but the later lessons were not yet that well defined. Nor do written lesson

plans convey the extent to which the setting of tasks, roles and interactions had been envisaged. However he had a clear picture of how the first lesson would develop. At lunchtime on 14 May, having resolved how to fit the TV programme into the sequence of lessons, George reported his image of the afternoon.

He planned for a five minute introduction to the task, expected it to take only a few minutes for the children to make their own cotton reel tanks, leaving the rest of the time for testing them and viewing the TV. After playtime they would do some outdoor work on the hedgerow to give some variety to the term. He anticipated few problems and saw the experiences as introducing scientific ideas as well as providing a reliable basis for the children to devise and carry out their own investigations.

Well its a very straight forward task isn't it . its not exactly fraught with difficulty . what they're doing today and I don't think there is anything that they will .. either dramatically succeed at or dramatically fail at .. but they'll . I hope . just be getting the idea of storing energy in an elastic band and .. trying to make the thing run as smoothly with as little friction as possible and then as much grip on the floor as possible to get it going up the slope .. that's all I'm introducing to them .. the idea of .. storing energy .. getting some friction on the . wheels.
(Conversation 14/5/88)

He explained to me the expectations he had for the way the pupils and he would be working during the activity.

They're just . experimenting in the real sense that they're . just the sense that they're just going to try things out/ I'll just let them go . I don't imagine anyone's going to have any problems at all with it

R: What's your role going to be? Do you anticipate

doing anything to the groups?

George: I think just going round and - talk with each group . just say to them "yes that's fine" (maybe) "just scribble a note of that" or "can you just do anything different?" or "can you improve on that design?" or something like that . or "what band . what rubber band should you use here?" or "what do you think you ought to use there?" . yeh . that sort of thing.
(George's lunchtime conversation 14/5/84)

So George donned his tape recorder and was ready to set the task and see how that image worked out in reality.

10.3 Setting the Task and Into Action with Bobbin Tanks on 14 May

At 1.25 pm on 14 May the class was settled to hear George tell them they were going to make bobbin tanks. There was an enthusiastic response to this and the announcement that a TV programme would follow, with some banter as Dean inquired whether it would be 'Playschool'. George demonstrated a ready made bobbin tank and set the task in the context of powering vehicles.

Those bobbin tanks are very . straightforward things to build . I'll just show you one now that's already made ((he demonstrates a tank he has prepared))

What I want us to do . the programme on the television is about making cars or vehicles like you made last week but attaching some form of motor to them so they will travel under their own power .. these are the simplest vehicles you can make . that travel under their own power . all I want you to do this afternoon is . to make one . so you've made a simple vehicle which travels by itself. (Audiotape 14/5/84)

After regaining the attention of a few distracted pupils he suggested ways they might investigate and improve the performance of their tank.

What I'd like you to do when you've made it is investigate how it works .. I want you to try things out like how many turns do you need to wind it up before it will travel at all? In other words how many turns of the elastic band do you need for it to travel? When its unwound perhaps you'd like to see . unwound completely . perhaps you'd like to test . if you wind it up . 10 times how far it will travel then allow it to go . maybe 30 times if that's appropriate unless its going to break the band . see how far it goes then . see if you can alter the distance it travels by using a different elastic band ... see if you can improve its performance by .. lessening the rubbing between the wax washer and the bobbin in some way . see if a tighter piece of wood or a heavier piece of wood works best . see if you can make it go up a slope and see which is the maximum height of slope which it will go up . see if you can improve its ability to climb slopes in some way or other.
(Audiotape 14/5/84)

Having offered those suggestions George pointed out the materials, checked that pupils understood the task, and set them to work for 40 minutes in the same groups as last time. They began to make and try out their tanks. Several children came to ask him about the use of materials and the likely results, but he only supplied any help after they had tried for themselves. For example, after Dorothy had failed to devise a way of threading and fixing her elastic band through the cotton reel he assisted her. To Rebecca's query about fixing the stick on he replied "I don't know. err. or I do know but I'll ... see if you can find out first." When he returned to Rebecca's group at 1.50 he was however more directive, helping them to fit their band.

George: I'll just give you a bit more help
because you're very - very far behind

Rebecca: . we couldn't find a bobbin

George: I see you spent all your time doing that
. eh . ohh you are a terrible lot aren't you
. such clever girls and you spend your time
messing about in such a peculiar fashion
don't you .. brains the size of planets
and here you are messing about with this
stuff ((he teased them further and they
responded in kind))
(Audiotape 14/5/84)

Most of the children were by this stage involved in modifying and testing their tanks. They had more problems than George had envisaged but these were indicating improvements and investigations they could explore with a little help. As he moved from group to group George was in most cases able to carry out his intended strategy of encouraging and extending their ideas. When Luke and Danny tried different bands he suggested they kept the original one to check their findings.

Some children were experimenting in the way which George had defined over lunch, ie simply trying out things such as different bands or surfaces. Others were beginning more systematic investigations and some were measuring and recording, as George pointed out to me. The class was busy, with lots of movement and talking about the task. From time to time, as a group shared a pleasing result with others, there was a focus of excitement.

Dorothy, with Deborah assisting in a very minor role, developed a successful tank and fitted it to the car she had made previously.

At 2.05 pm she called George to see it move and he praised her,

then asked what would happen if she used two. As she went to begin to make another he came to tell me about her progress. Fifteen minutes later while the class were being urged to tidy up and gather round to watch the TV programme she completed her model with a second bobbin tank and got it to run slowly. She brought it with her as the class gathered round to view the Uphill programme.

The pupils' attention ebbed and flowed as they watched, seeming keenest when the children on the screen were seen testing their vehicles uphill. Luke and a few others watched intently throughout and commented on the need for power and on the different sources illustrated. George related the examples seen to their own elastic-powered tanks. Before they went to play at 2.35 pm he told them there would be an opportunity to see it again and they might try some of the ideas, perhaps having a race and later designing their own vehicles.

At playtime George told me that it was about time to halt the activity to stop them becoming aimless. He had decided that they were at the stage when they needed some direction, and on the following day he would get them to decide on a specific test and jot down what they would do. He hoped not to have to structure it for them but if they were short of ideas he would summarise some on the board.

The lesson had developed along the lines George had anticipated,

but not as far as his plans envisaged. Some children took longer to master the making of the tanks than he had predicted and few had planned any systematic investigations. However, early in the lesson he had adjusted his original plan slightly in the light of pupils' responses. At 1.45 pm, when pupils were engaged in their activities, George had paused to remark to me that it all seemed "gentle, easy stuff" and though he had told a few people to record things there seemed not to be a lot of point, and he decided at that point it was better to leave them to their initial explorations.

I think I'll just let them play ... (in the next lesson)
they'll need heavy direction to say this lesson we're going
to find out ((he lists investigations))
(Audiotape 14/5/84)

This could be interpreted simply as the fine tuning of a lesson plan - an interactive decision prompted by a cue from pupils. However it was also a personal decision and could be related to George's belief in the value of pupils' exploration of materials and a 'play stage' in learning.

On 15 May he gave the children ten minutes to write in their jotters what they wanted to find out with their tanks and how to try it out. These would be put into practice on Friday 18 May.

10.4 Continuing the Bobbin Tank Investigations - 18 May

On the afternoon of the 18th the class entered late and rowdily after playing and took a little settling before they were ready with jotters, pencils, rulers and tanks to test. George recalled the plans made on the 15th and some pupils read theirs out. He quoted the examples read out to emphasise the need to think about the questions they had set themselves. George often prefaced the lessons I observed with similar emphasis on thinking about the task and here he had been explicit about the elements of that thinking. He began by asking the children to "look and think about the questions you've asked yourself .. first of all (ask) 'how can I answer my own question?'" He repeated in several ways the need to identify the problem, turn it into a testable question, decide how to do it and what to observe, and to record results in a way which would help their later interpretation. After he had asked if anyone was uncertain what to do the class was set to work for about an hour in their groups.

Danny and Luke referred to their jotters and talked over their plans to investigate how a tank would travel up smooth and rough boards (see figure 10.1). George came to their table and inquired about the surfaces of the boards and how they would carry out their test.

George: OK right . so you're going to try it on
the smoother board . how are you going to .
err . test . that it its going up more easily

Luke: We thought we'd put it on a certain height . then measure how high it is .. and wind the tank up for so many (circles) and test that its going then time it

George: time it?

Luke: and the one that takes it longer we can tell that its easier or not . I think it'll climb better if its bumpy

George: on the rougher one - yes?

Luke: rough

George: will you wind it up the same number of times each turn?

Luke
& Danny: yeh

George: and how will you make sure that its all unwound?

((they demonstrate their method))

George: all right I'm with you - OK
(Audiotape 18/5/84)

George's questioning had checked their plan with them, but confirmed their ownership and responsibility as he intended. When the two boys had their materials ready I asked them to carry out their investigations in the adjacent office where the videocamera was set up.

Meanwhile George had moved on to talk with other groups. Dorothy explained how she and Debbie were systematically going to do three tests up different surfaces. She was less clear about what this would reveal. George probed further but when they declined to define a more precise question or investigation he accepted that.

George: You just want to try it out . nothing more? . You don't want to say .. "I could maybe try a slope and see if it had a rough surface . a smooth surface . or sandpaper or cloth"? .. you want to just see how it goes? yeh? OK . right . go on then.
(Audiotape 18/5/84)

He did check that they would control the number of winds before he let them go outside to work on a bumpy surface. When George came to see how Rebecca's group was getting on he was much more directive, giving suggestions for setting up their slope, and remodelling their sluggish tank. Rebecca had her attention drawn to the performance of the improved vehicle before he left them to carry out their test. George paused to tell me that he had decided to "do it for them and get them to the point where they can get started - as they're so disorganised". He reported that he had helped at least three groups with basic craft skills but felt the task was at about the right level for the class and that it was proving very useful for him to have to keep asking "What do you want to find out?" instead of what he wanted to find out.

George circulated among the groups of children who were working all round the room, with a few outside. Luke and Danny were in the office. The first time he called on them much of the conversation concerned their hypotheses about the different surfaces. He probed these, asking the two boys if they agreed and adding some questions and suggestions to relate the various ideas and terms they were using. Later Luke went to find George and excitedly reported a failed run and their intention to try it

out once more. They were concerned to repeat and check their measurements but on his next visit George warned them that they might not have time to compare their results. Subsequently they discussed with him their interest in the effect of rubber band 'tyres' round the cotton reel. On his last visit, five minutes before play, he had time to join in and hear more of their ideas about the different performance of the tank with and without 'tyres' made of rubber bands on varied surfaces. He checked himself from putting his own interpretation on it and inquired into their hypotheses.

Danny: No tyres/

George: no tyres . its going up fine is it . so obviously this .. so obviously what?

Luke: it's gripping it much better

George: mm ~ humm - mm

Luke: it's just like . cause . the sandpaper's rough . and . with no tyres it . it can't fall backwards cause there's a grip on the sandpaper

George: Luke . was that surprising you?

Although he was encouraging them to try out their own ideas he was becoming more involved and directive as time ran out. He introduced a quicker way of testing by tilting the ramp until the tank was just stationary and measuring the height.

George: What? oh that's no . I think that's alright and then seeing if it'll do any better with tyres on the rough surface

Luke: errm

George: do you think - is that worth while finding out?

Luke
& Danny: yes ((very quietly)) it will - aah

George: so measure that

Luke: 21 centimetres

George: don't forget to measure there again -
so 21 centimetres

Danny: two blocks ((referring to blocks used to
raise slope))

George: stick it . stick its tyres on . let's find
out how many blocks you need for that

Danny: I can get em on Luke

George: 21 centimetres?

Luke: yeh . thats 17 you see

George: yeh . so if I shove it closer to the base
. you'll find that you get a steeper slope like
that . there we are

Danny: we could get some books to help us

George: mm . maybe . that seems OK

Luke: got it now

George: now we've only got a short time to try it
(Audiotape 18/5/84)

George was called back into the classroom at this point to sort out a 'sticky incident' with some glue. There were only a few minutes before playtime in which to tidy up. Over play he told me how tired the class seemed today; we agreed that all of us had a "touch of the Friday afternoons". So after play there was only a short plenary session in which he explored the children's explanations of how the tanks worked and discovered that only six children had made them before. A few volunteered reports on their investigations. They included Luke, who reported on the

question they had posed and their methods and findings. This was later written up as shown at the start of this chapter in figure 10.1.

After the lesson George commented that Luke's report and one other, by Dean, were quite interesting but the others were being rather cautious and seemed tired. He gave them half an hour to complete any work or choose their own activity. He remarked this was a "pleasant little half hour" which incidentally helped with his long term goal of increasing their independence. The afternoon finished with him reading a story they had requested, and the science topic was adjourned until the following Thursday.

10.5 Onto the Design Task - 24 and 25 May

Nearly a week elapsed before the class as a whole returned to the topic and I was back in school. On the morning of 24 May George summarised his plans for the day as we talked at playtime. He planned to allow time for some pupils to complete the writing up of their findings before reshowing the Uphill programme. Then, after he had set the new task of designing their vehicles, the children would have all afternoon to work at that.

At 11.20 am he called the class together and commented on the written work he had seen from the tank investigations, stressing the need to write some sort of conclusion to answer the questions they had investigated. He outlined the next task, making links

with their earlier vehicles which might be adapted or cannibalised, and with things they might have learned from making the cotton reel tanks. The children then watched the TV programme closely, but were more restless when he paused from time to time to relate it to their task.

George: Last time with the tanks . with the bobbin tanks I asked you to plan your . investigation yourself . plan before you actually did them . this time I'm going to ask you to plan how you're going to make your vehicles . what you're going to make it from and also what power source you're going to use before you do it . so this is what this woman's referring to on the programme in the design (of) your vehicles. Before you actually make it you must have a clear picture in your head of what you're going to make .. and so I'm going to ask you to design it first . nothing elaborate . just some notes . few diagrams . so that . we can discuss together what approach you're going to use . any questions anyone . no?
(Audiotape 18/5/84)

When they had seen the rest of the programme they looked at some examples of their own previous models and George recalled the problems of overpainting and the need for smooth running wheels. He set them to jot down designs but most groups were eager to begin making, all the target pupils looking at their models for ways to use the ideas and bits to develop new solutions. George remarked to me that they were reassessing those models in the light of the TV programme. The class was getting started as lunchtime approached and he reluctantly stopped them, saying they would have the whole afternoon to pursue their ideas. Over lunch he commented to me on how they had plunged directly into the task, or begun by collecting materials and seeking power sources,

rather than designing first as he had suggested.

George: this design thing . they don't seem very happy with it ((laughs)) they seem to want to just get hold of the wood and get working on it . I think its probably better. I'm not all that enamoured . see how it goes . those who want to I'll sort of make noises that they ought to design something . but if they don't . they just get on and start doing that's what I'm after really I think
(Conversation 24/5/84)

I explored his views on this further.

R: Certainly very few went to their jotters and started to draw things down and/

George: /Yes .. I .. yeh . I don't think most of them feel the need for it . at this stage . I don't think that they are . sophisticated designers yet or they just thought "I want a car with an electric motor" or something and they just want to get an electric motor because it was the first thing .. and do something like that

R: Do you think they should feel the need anyway?

George: No I don't think so .. no I think that . errh . I suppose just for my own disorganised self that's how I work very often . say if I want to make a bookshelf I don't sit and draw it out first .. often I'll think about it but then I'll pick up the wood and start.

R: because you said to them . things like you know "You're going to do a little bit more design" and "I want you to plan the way"/

George: yes I did but they obviously didn't take any notice of that
(Conversation 24/5/84)

George then told me that he envisaged the afternoon being spent largely on more construction of their vehicles by the groups of children. He would simply help groups, only stopping the class

if there was reason - such as a good idea to share. If anyone were ready there might be a little trial run at the end, with some talk about a bigger event the next day and checking if any resources were needed. He only expected about half the pupils to get a vehicle running today however.

After lunch the children got straight to work. Dorothy started by sanding wheels and getting her jotter ready. Once he had talked with George about fixing axles and elastic band transmission to their old frame Luke began, Danny fetching him some card and a craft knife. Rebecca's group wrote, then collected materials to construct a support for a propellor. From time to time they sought help with making this from George. As he moved round the groups most of his interactions were to help children with techniques and materials. At one point he discussed with Danny, who was choosing wood, the need for more energy to move a heavier vehicle. Around 1.40 pm he told the class "I'm pleased to see some of you really thinking about your designs" and encouraged more of this. Ten minutes later he commented to me "it's going alright - they're just getting on - and there are lots of ideas". But as the afternoon passed some groups fell behind and his comments to pupils and to me increasingly reflected this. Revisiting Dorothy and Deborah he finally told the latter she was wasting her time; Rebecca frequently wandered round seeking materials and help, and snapped two blades in a craft knife attempting to cut wheels. Before playtime he gathered the class together to share what had been

achieved and to spur the rest on when they continued after the break. At the end of the day he reported to me his frustration over the lack of enthusiasm shown by some children at the opportunity to do this practical task, which he presumed to be interesting. He suggested some of that might almost be a response to having to think for themselves. However he qualified his judgment by noting that many pupils had got on and results were beginning to emerge, recognising that the activity was time consuming as he had tried it out; he added that this phase of a lesson was always long-winded. He decided that the next morning would be more directed and desk-bound to "get their heads down", probably with some follow up to today's task in the afternoon.

That evening he tried making a propellor-driven vehicle himself and experienced some of the difficulties children were having with mounting motors and propellers, and the transmission. Many of them had been stimulated by the TV programme to try solutions which involved skills or materials that were not familiar. This was providing challenges, and some problems, for George's practice as he sought to support them in realising their ideas. It raised general dilemmas over skills, time, his interventions, and pupils' work which were explored later.

His more immediate thoughts were concerned with how to present and organise the lesson on the afternoon of Friday 25th. By the time it arrived he had decided to give the children a free choice, as he often did just before a holiday. He was interested

to see how many would opt to carry on building their vehicles.

In fact about one third did, including Luke and Danny who rushed for their model. George pointed out to them that he had noticed their axle binding and they agreed that they needed to shave down their wax washer. They made elaborate fittings for their vehicle, George intervening at one point to suggest they try more elegant alternatives to sellotape for their window and later demonstrating the use of a drill when they needed it. When Dorothy eventually built a simple drive with a Legotechnic construction kit George offered the idea of a pulley and supplied a workcard to develop ideas relevant to her model. Rebecca's group decided not to work on their vehicle at all but told me they liked the choice and most of the time preferred the practical challenge to being told exactly what to do.

10.6 Difficulties and Dilemmas - Reflections on 27 May

The class left for a week's half term holiday and it was to be almost two weeks before they returned to the task. Over the holiday George and I met for a long interview on 27 May during which he reflected on the progress of the work and of different pupils.

George: Halfway through a topic like this ..
you .. you come to a point where you think ..
that .. you're not getting on as well as you
thought you might do .. you're not getting on
as quickly and efficiently .. because you're
letting them organise themselves and they're still
very bad at organising themselves .. but that's
the whole point of letting them do it ((laughs))
that they're going to get better at it ... and I
don't think they'll get better at it until
they've tried it out.
(Interview 27/5/84)

George was facing a dilemma, which was more acute with some pupils. Luke and Danny he saw as exceptions, because "they're the sort of organised group they are" but Rebecca illustrated the other extreme as she "hasn't a clear enough idea in her own head of what she wants the thing to be in the end". These tensions were as yet unresolved in George's mind.

George: The whole idea is to make it . try it out
. test it . and then go back and change it
... but they're not at the point of being
able to do that quickly and efficiently
enough so we're getting bogged down ... there's a
bit of tension there in my own mind.
(Interview 27/5/84)

Dorothy's difficulties raised a different but related dilemma.

George: She's finding the mechanics of it very
difficult .. like just glueing together
accurately and neatly .. that in a way is getting
in the way of what I'm aiming for to do errhum
. so that is a problem .. she in fact in someways
more .. direction .. more clear direction
.. the mechanics of putting the thing together

R: mm . and have you been responding to her problems
and Luke's problems or absence of them or whatever
and Rebecca's in different sorts of ways?

George: Trying to but not in .. not in different
enough thinking about it actually .. I've been
trying to give Dorothy still time to do it
herself and to do it .. do it herself and probably
I ought to be sitting down with her to say for
say five minutes "do it exactly like this ..
and this is how you'll make a successful
model .. and then when you've made a successful
model you can then try it out". I'm maybe giving
her a bit too much rope to hang herself at
the moment.
(Interview 27/5/84)

George's reflections in this interview and subsequently indicated

a number of related dilemmas which are analysed in the discussion at the end of this chapter.

Over the week's holiday he had done some further preparation for the children's continuing task of powering their vehicles. A shortage of propellers had led them to request alternative power sources, including balloons (perhaps stimulated by the contemporary offer of balloon cars on cereal packets). George had got more ideas from published sources, such as the ASE Primary Science Newsletter (ASE, 1983) and a Science from Toys unit of Science 5-13 (Radford, 1972). He planned to restart the activity on the Thursday afternoon after the holiday.

10.7 Difficulties and Decisions - Action and Thought on 7 June

When I arrived at 10.30 am on Thursday 7 June several pupils asked George if they could start, rather than wait till the afternoon, so he conceded that one in each group could "do something sensible" with their vehicles. All the target pupils chose to. George immediately got involved in helping Luke improve his broken bearing, and raised the possibility that he might later use a pulley. Rebecca sought help with her propeller and after giving that he drew out her group's idea from seeing it work as a 'crawler' with the propeller touching the ground; before leaving the decision to the children he summarised the possibilities.

George: Well there's two methods there aren't there?

There's the possibility of using it like a gigantic tank . and there's the possibility of a propellor . so if one doesn't work . you can fall back on another one.
(Audiotape 7/6/84)

Over lunch he reaffirmed his frustration at the time and effort pupils were expending on simple mechanical problems such as gluing and told me that he was being a little more directive in this respect. At 1.25 pm when the whole class was ready George set a 3.00 pm deadline for vehicles to be ready for initial testing on the flat. He stressed the time limit and advised the groups to divide the work for efficiency and warned them against wasting time.

Luke and Danny needed some guidance on fixing an elastic band to the axle; they worked on without stopping for playtime, reporting their progress or problems at intervals to George who was sometimes too busy with others to respond. Rebecca, who frequently came to him for materials or advice, made slight progress. Dorothy announced that her battery-powered model would not work and George gave her some incidental teaching on electric circuits. During the afternoon an adviser and a parent called to chat with George and he was in demand from pupils. There was increasing pressure on him, and from him, as his frustration mounted over their failure to get on. His recorded interactions conveyed this and he confirmed it in his comments to me at playtime. He also noted the need for him to become even more directive because pupils were finding it difficult to successfully fit drive units and operate them. As the elastic

bands were proving under-powered he showed Rebecca's group the balloon-drive idea and later demonstrated it to another group, leaving the problem of fixing it up to them. When Rebecca later showed her solution to this he offered a bottle top as a valve to control the flow of air and fitted it while lots of children gathered round to watch.

Although the 3.00 pm deadline had passed few groups had vehicles ready for test runs, Luke and Danny being among the exceptions. The class was set to tidy up and George commented again to me on the frustrations and lack of progress. After some thought he attributed this to the shortage of good materials and the inherent difficulty of fixing a power source, as well as the pupils' lack of good ideas. He told me he had learned that he should have been more directive over the process of making the models rather than being so free and easy.

There was no full contest or plenary discussion but in the short final whole class session, when the few completed vehicles were demonstrated, George asked the children to consider what lessons they had learned.

George: What I'd like to do in the last ten minutes is . to begin . the process of you telling us what you've learnt . so that possibly we can .. errh . learn any lessons and improve our models next time . cause we'll continue with our lessons and although these models have proved particularly troublesome . we'll maybe move on to something else soon and maybe have a bit more success with that.
(Audiotape 7/6/84)

A few volunteers explained their progress and problems, including Rebecca.

George: C'mon out and tell us now I'm astonished Rebecca .. in the . errm . three minutes that we were clearing up Rebecca has made some decent sized .. bearing for this wheel and yet its taken her around about . how long Rebecca? . three days before that to actually make decent sized bearings.
(Audiotape 7/6/84)

He got Rebecca and one of her partners, Carol, to discuss the difficulties they had using this card and their ideas about how a propellor would drive the vehicle. This led some pupils and George to talk of force, but only a few were attending to this when the bell signalled an end to the lesson.

George's comments after the lesson were further stimulated by viewing the videorecord of those final ten minutes. He was generally very disappointed. He felt that although there had been lots of incidental learning it was not enough and he should have been more directive. He was concerned that the frustration could not have done any good. However a little later he commented that, on reflection, he felt they had learned a lot to which they could return and use more systematically later because of their experiences. He also thought out loud about whether the highly structured design approach of the TV series might be right after all.

His postactive reflections were an extension of his thoughts during lessons. He could qualify them to make a more general

evaluation of the activity in this unit and look ahead to the implications. Some reviewing of his own beliefs about teaching skills was prompted by the difficulties and dilemmas, and he would return to think further about this later. Meanwhile he had come to a more immediate decision in the light of his evaluation:

After today I'm definitely going to have a nice directed lesson so that we can have the confidence it will work .. I think it will be the mangonels .. and then we'll regroup and do the vehicles when we've more batteries.
(Fieldnote 7/6/84)

Before following George and the class with that activity in the next chapter my interpretation of his thinking based on the data so far is summarised here.

10.8 Discussion of the Analysis of George's Thinking and Primary Science Issues

George's planning and thinking in lessons have been analysed and some more general reflections identified. The elements in his thinking were closely connected with the action and with one another. An integrated account of thought and action as they develop over time can convey this complexity, but it is also necessary to analyse elements and relationships within that account.

10.8.1 Planning thoughts

At the beginning and end of this unit George came to quick

decisions about the introduction of a new activity. In each case he was influenced by his evaluation of the previous lesson, but this was no isolated decision. He was concerned with pacing and sequencing activities within his longer term framework of goals and strategies. This provided further evidence that George's planning was a complex, layered process involving reference back and forth as well as between layers. George gave examples to show how the flow of activities over the term was still at the back of his mind as he came to the more immediate planning decision about when and how to introduce the next task. Situational constraints such as time and resources had some influence along with his perceptions of the class. Much of this planning occurred alongside the teaching of the previous activity, which represented the realisation of an earlier plan. There was repeated reviewing of possibilities, illustrated here by his reflections about using the TV programme. He focussed his images of how the action would develop over the unit, bringing each lesson into sharp definition as it became imminent. At that point he could envisage the likely flow of activity through the time available, his role and pupils' responses. This moving image closely guided his performance.

10.8.2 Interactive Thinking

The pupils' mediation of the task played an important part in the realisation of the imagined lesson. Resulting discrepancies between image and reality may cue a teacher's thinking and lead to decisions. For instance on the 14 May George had extended

the time planned for exploratory activity and deferred the moment when pupils had to specify a systematic investigation. In later lessons there were increasing gaps between what he had imagined and how the lesson developed in practice. George's thinking was becoming more complex as the gap between image and reality widened in later lessons. His thinking in the lessons of 24 and 25 May, and 7 June included: his persistence with the planned approach; a deferred decision to modify his interventions; the identification of sub-goals and time limits for the class; reflection on his overall goals and tensions which were emerging; and the seeds of a re-examination of some of his teaching approaches. Interactive thinking as well as planning may be more fully understood if the analysis takes account of the teacher's wider frame of reference, as Morine-Dersheimer (1984) found in her own reanalysis of data from stimulated recall, observation and repertory grid interviews with four teachers.

That frame may include a concern to individualise interactions with children within a common activity. George had made explicit his intention to do so, against a broad principle of restricting his interventions. Interactions with target pupils have been reported in this chapter. In active lessons they may be central to the promotion of inquiry learning, but not possible to anticipate and rehearse. They may be constrained by time and the multiple demands on a teacher. Records of such moments may be revealing for an analysis of thinking and action. For instance on 18 May George sought to combine his various goals for the

activity and his intention to individualise his interventions. As the time ran out it became more difficult to sustain his strategy of allowing children to develop their own ideas and make mistakes; he was heard stopping himself from giving Luke and Danny his own interpretation of their observations, and he was becoming increasingly directive. Such tensions are characteristic of teaching, and their resolution during interactions is rarely a simple choice between two alternatives. It involves thinking-in-action which may be largely tacit and hard to unpack for practitioner or observer. Sometimes however it may be made explicit and reflected upon, as it was occasionally in that lesson. The tensions and pressures of teaching may in fact be a productive starting point for such analysis as Lampert has argued.

..it seems appropriate therefore, to consider the notion that teaching involves inventing personal strategies for working with universal contradictions that cannot be finally resolved. Coping with these conflicts in one's self seems related to how they are managed in practice, and we need to persist in trying to find out how teachers do cope, in practice with these enduring and unresolvable tensions. (Lampert 1983, p1)

In Lampert's later work (1986) she has analysed strategies that teachers use for coping with such tensions, and shown how the analysis of dilemmas can broaden our view of teacher thinking. In this chapter a number of dilemmas facing George have emerged.

He had to manage them in the particular context of this topic but they were universal contradictions, in Lampert's phrase. They are summarised below in polarised statements. In George's

practice and thinking they were closely connected, as illustrated on 27 May in such comments as

George: I've got a problem ... because I'm trying to keep them doing it themselves I'm ... I could make it much more efficient ((George illustrates how he could direct pupils to make a vehicle)). Now that would be efficient and they'd get through it quickly ... they'd do it much better than they're doing it at the moment .. that wouldn't be getting what I want them to do .. to get out of it that is .. independence and being able to organise themselves .. there is a great tension there ..
(Interview 27/5/84)

Dilemma 1 - Time

Pupils need time to pursue their own investigations

but

time is limited in school, lots of other things have to be done, and teachers feel that tasks should be completed.

Dilemma 2 - Intervention

Children need to try out their own ideas, make mistakes, use their initiative

but

teachers can see missed opportunities, they need to help prevent failures and frustrations - they are there to teach.

Dilemma 3 - Process or Product?

The particular process pupils go through and the experience matters more than the particular products such as written reports and models

but

stressing process can mean lots of time is spent on activity with little visible evidence of learning and any final products may be disappointing.

Dilemma 4 - Skills

Skills, techniques and more general approaches like scientific investigation and the design process are taught most effectively when pupils see a need

but

it is insufficient, unsystematic and frustrating to leave the teaching of skills and general processes to chance, and not to distinguish the different elements.

10.8.3 Theories

These dilemmas are more than management problems, and have the potential to stimulate teachers to review their theories about teaching. George began to do this at the end of this unit when he briefly wondered whether he should reconsider his view on the teaching of skills and his criticism of the design process advocated by the TV series. His own reservations about the emphasis on that process had been prominent early in this unit when he was considering the use of a programme. Even though he planned and set a task requiring preliminary designing on 24 May he did not insist on this when most pupils largely ignored it and went directly to model-making. His comments on this were noted above; he had in fact remarked before the lesson that "I'll sort of make noises that they ought to design something . but if they don't . they just get on and start doing that's what I'm really after."

It seems his underlying belief about learning was a determining influence when it came to the lesson and the introduction of an

alternative view was insufficient to change practice. However dilemmas in that practice may stimulate review of a personally held theory against such alternatives. His theories as elaborated in the interview at half term have been discussed in Chapter 7. In this chapter they have surfaced incidentally in connection with the action. By reflecting upon that action and his dilemmas he was able to extend his own pedagogical knowledge. For example during our half term interview he said that it had now become quite clear to him that his role should be "where they've got ideas .. don't do much except help them in their own clarifying . where there are materials or skills be quite prescriptive."

This general principle could be applied in new situations as he met them. Its immediate application will be traced in the next activity, in Chapter 11.

10.8.4 Primary Science Issues

This chapter has raised some general issues concerning primary science. In the Uphill activity George was only seen to make limited use of opportunities for teaching concepts associated with the investigations. His emphasis was firmly on the skills such as posing questions, designing and carrying out tests and related construction techniques, and on encouraging pupils to try out their own ideas. The pupils' involvement in class discussions was even less than in the last unit, when he had

remarked upon it. Their difficulties with construction had curtailed the testing he had planned. There are various task demands in these sort of activities which are often subsumed under broad headings of problem-solving or technology. It is perhaps necessary to experience them in practice with a class as well as try them for oneself before they can become an element in the repertoire of pedagogical knowledge. However there is a risk that children will choose solutions to their problems which are unpredictable or demand unfamiliar skills. Some pupils faced difficulties with construction, or approached investigations in ways which he had not anticipated. In the exploratory approach to teaching and the promotion of inquiry learning in which George was engaged these tensions could be seen. He was at this time using activities that were relatively new to primary science, and to him. His own experience could inform future practice by others as well as himself if it could be reflected upon and shared. These issues are developed in later chapters. In active science lessons the opportunities for a class teacher to reflect are limited, although the potential is there as illustrated by the comments George was able to make during or after lessons. Even so he remarked at our half term meeting that "you're too busy ... you can't sit back enough and think about it"

CHAPTER 11 MAKING MANGONELS

11.1 Introduction and Overview

As reported in the last chapter, on 7 June George had decided to adjourn the making of powered vehicles and to introduce work with a different model, the mangonel or siege catapult. This chapter opens with that decision and the associated planning, leading to the introduction of the task on 12 June. The children were set to make simple models and modify them so they fired more accurately. This is illustrated by Dorothy's report on her work in figure 11.1.

On 15 June, after George had explored some of the children's ideas about the trajectories of the missiles they were firing, they had to devise and carry out their own investigations with the mangonels. The historical context was used on 21 June when he set them a problem he had devised. This involved the pupils in considering more than one variable as they simulated a siege, and reporting back in the form of advice to their General (George). In the final lesson of this unit, on 2 July, he posed a problem which reintroduced the craft and design element. He asked them to make devices for controlling the firing of their mangonels more remotely and realistically. Table 11.1 outlines the sequence of the action and the data.

Report on a mangonel

The mangonel is a machine the Romans used. It was like a giant catapult. You put a big ball in like a big cup and then you they cut the big rope that held the mangonel down. We made a mangonel we got a board of wood a peg four nails a stick of wood and a pin.

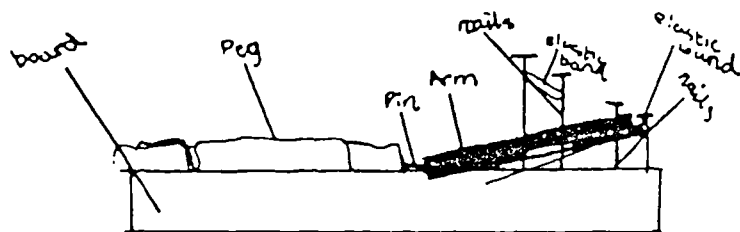

After that we got some plasticine we got a small bit of the plasticine and two big bits we made the 3 bits a plasticine into 3 different size blocks. We got a book, a book for a city wall and a big piece piece of grey paper we marked a target in the middle of the grey paper and we tried to get all the plasticine to land on or near the target

Figure 11.1 Dorothy's report on her first mangonel task

TABLE 11.1 OUTLINE OF THE ACTION AND DATA IN
'MAKING MANGONELS'

<u>Date</u>	<u>Action and Comment</u>	<u>Data</u>
7 June	Teacher's decision to finish 'Uphill Struggles' and start 'Mangonels' Refers to published source	Fieldnotes Copies of 'Science 5 - 13'
12 June	First lesson making and firing mangonels	Teacher's written summary of plan Fieldnotes Audiotape of teacher Written note Videotape
15 June	Second mangonel lesson - short session on trajectory then pupils plan and carry out their own investigations Pupils interviewed	Fieldnotes Audiotapes of teacher Teacher's written note. Audiotape of pupils
20 June	Pupils writing up work	Copies of pupils' work Teacher's written note
21 June	Lesson simulating a 'siege' Pupils investigating and applying knowledge	Fieldnotes Audiotape of teacher Videotape
27 June	Telephone call from teacher reporting progress and plans	Written note
2 July	Final lesson on 'Mangonel' unit' Design brief for pupils to make control for their models	Fieldnotes Audiotape Videotape Further writing by pupils.

The discussion in this chapter extends the interpretation developed in the previous chapters. It explores relationships among aspects of thinking and practice, tracing George's management of dilemmas that were summarised at the end of Chapter 10. Particular attention is given to relating aspects of George's theories to his practice and to discussion of more general issues in primary science and technology.

11.2 George's Planning

Chapter 8 described how George identified potential activities from his repertoire, summarised in figure 8.1. In Chapters 9 and 10 the selection and shaping of activities has been detailed. A similar process was evident in the planning of the mangonel activity. It too illustrated the longer term consideration of possibilities, an eventual decision to introduce it at a certain point and the short term preparation for its implementation in particular lessons. There was also more evidence of how George drew upon ideas from curriculum materials to extend his repertoire, adapting them to suit his goals and the situation. His plans became increasingly original and later lessons were not planned at the start of this unit but were created as it developed.

At lunchtime on 7 June before the lesson in which children were testing vehicles, he had commented that he expected to continue that work for a week or two before moving on to toys, using ideas

from Science 5/13 publications and the opportunities toys afforded to develop process skills. He felt they would take less time than building vehicles, and he pointed out to me how he had alternated simple and more difficult tasks "from the point of view of pace". He was thinking of doing "something like a simple mangonel next with instructions on how to make one, then later a touch more freedom ... maybe with rubber-band toys." As we saw in the last chapter, by the end of that lesson a decision had been made to bring forward the mangonel-making. This was to begin with a more directed activity than the children's making and testing of vehicles which was becoming frustrating.

The possibility of making and using model mangonels had been in George's mind since Easter when he had consulted the two Science 5 - 13 Units: Science from Toys and Science, Models and Toys (Radford, 1972; 1974). He had considered the ideas introduced in the first (see figure 11.2) and extended in the second.

After the lesson of 7 June, George had consulted some further sources on this activity (eg Gilbert and Matthews, 1981-84). When he finally came to use it he had adapted it to suit the situation.

At home he modified it and tried it with his seven year old son, Sam. The night before the lesson he spent some time on it, woke at about four in the morning thinking about it, and then found that he quickly finalised his plans in the morning, as he told me

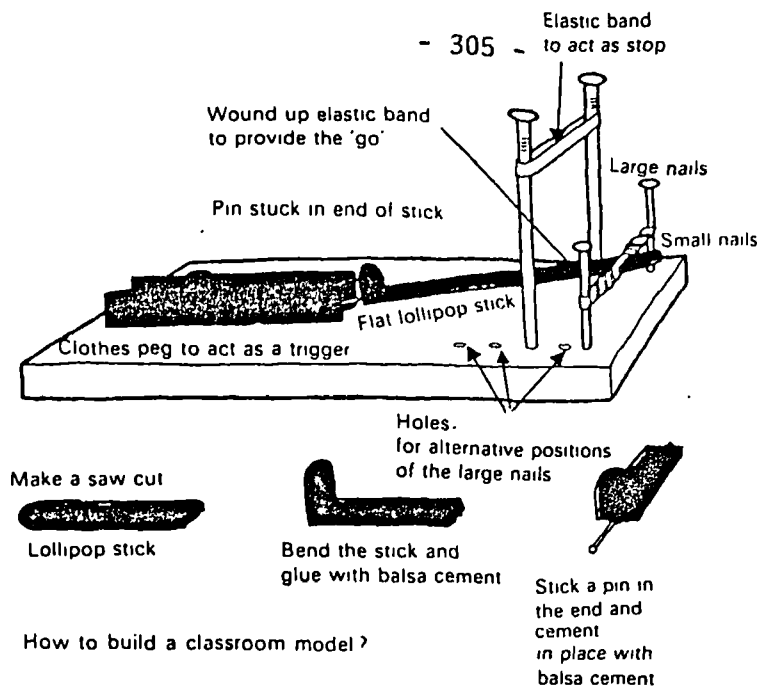

How to build a classroom model >

10.13.1 What science is there in this toy?

Observations and investigations

a. How far will a cherry stone go?

What effect does winding up the elastic have?

What effect does tilting the mangonel have?

What effect does altering the weight of the ammunition have? Try using Plasticine pellets.

b. If you keep the tension of the elastic constant, select cherry stones of the same size and keep the mangonel pointing in the same direction, do all the stones fall in the same place? Take a piece of black paper, put it on the floor and mark on it where each stone falls.

This is quite a task and requires some careful planning and deployment of labour!

What kind of pattern do you get?

c. Now pin or tape a piece of paper against the wall and find out what kind of vertical pattern is obtained. Note the mangonel will need moving towards the paper, viz the range will have to be shorter than in b: b and c could be summed up by asking what is the smallest target you could be certain of hitting, i. every time, ii. one out of every two times?

d. Can any method be devised to find out the path of the cherry stone? Before children try to find out ask them to draw what they think the path will be.

e. Alter the position of the large nails so that the arm of the mangonel (lollipop stick) is stopped in another position. What effect does this have on the range?

Hidden science

a. Where does the *go* come from?

b. Children can get experience of variables—how many different ways can you alter the range?

(Altering the elastic tension, the weight of the ammunition, the tilt of the mangonel and the rest

on 12 June. He summarised these in a journal entry as follows:

12 June

Mangonel

Reasons - continuing rubber band power theme, simple model with lots of interesting possibilities

Sam (his son) has made one at home and has enjoyed playing with it. I have made the base beforehand so that children don't get bogged down with the craft side of their work and get on to more fruitful work. I find that simple work on one small model shared between three children leads to lack of concentration. Children will have a chance afterwards to adapt their machine so that craft element is not missing.

Anticipated modifications

1. Addition of peg trigger
2. Change in arm, size and weight
3. Change in position of big nail rubber band stoppers
4. Addition of 'pan' to hold missile

First Activity

1. Show model - comment on use and time and places used - heads, fire, rocks, demolition, twisted hair etc.
2. Practical - make own model. General's command is to fire over a wall (Ladybird book) into the central compound with rocks to kill defenders. Mark accuracy of shots on paper after 5 mins play and 10 practice. (George's journal entry 12/6/84)

11.3 Setting the Task and Into Action on 12 June

At 11.20 on the 12th the class sat around George as he stood by the board. The mangonel was introduced in a historical context and his narrative interspersed with questions. He showed his own model and some pupils used it. Then he told them that the bases were ready for them to make their own model mangonels which they could then modify - for example they could be with or without a trigger. He introduced and summarised their task of using them

to fire two different pieces of plasticine over improvised "castle walls", represented by a book, and marking the centre and range of landing points on a large sheet of paper.

By 11.45 pm pairs of children were spread round the classroom and corridor working on the task. Rebecca had just fired her first shot, Dorothy was firing while Deborah marked where the plasticine missiles landed, and Luke was redesigning his mangonel. Five minutes later George reported to me his satisfaction that the children were quickly into action without the problems of construction met in the last lesson. He noted that this was a play stage and that he had realised there were so many variables involved he had decided to allow more time for their exploration, and then he would review these in a class discussion to promote more systematic investigations.

He did hold short class discussions just before and after lunch, focussing on the children's ideas as they tried to get their missiles to land consistently on one spot. After they had spent a further half hour investigating and jotting down what they did he called a ceasefire and asked for volunteers to report back to the whole class. Not many pupils were very forthcoming or systematic, but he was able to develop Rebecca's thoughts about how the height of the mangonel affected its accuracy and introduce the idea of scatter by referring to the pattern of hits they had recorded on their sheet of paper.

George: This is Rebecca's more accurate shot and

this was over quite a considerable distance
wasn't it Rebecca? From/

Rebecca: that table

George: /that table to that table there . and this
is their scatter . were any off the paper at all?

Rebecca: no

George: no . this was about 3 metres wasn't it?
((he draws round the pattern of hits and asks
the class to describe the shape))
(Audiotape 12/6/84)

By the end of the session George had interacted with all the pupils and managed a very active and fluid session, although he had to urge children on and sort out disputes over space during the afternoon. My notes recalled how many times I was moved by pupils as they adjusted their firing range or shifted furniture.

George's own evaluation included some reflection on how he could have sharpened up on the children's interpretation of results, as he wrote in his journal.

Looking more critically I feel I should have been a bit more rigorous with the drawing of conclusions and should have insisted in the case of Rebecca for instance, in her drawing of a graph to illustrate her results.

I think I originally steered clear of this greater rigour because I wanted to see what they would produce with little guidance but I feel that too few children found patterns in their results. There is no conflict with my original aims to let children try out their own ideas in then making them look more critically at their results. (George's Journal entry 12/6/84)

11.4 Ideas and Investigations - Planning for 15 June

Although George had confirmed over lunch on 12 June that the

progress of the children's investigations were his priority, he did make some comments on their scientific ideas and his approach to teaching those. This was prompted by the children's explanations of where their missiles landed. It led him to the more general elaboration of his views in later discussions and notes which have been analysed in Chapter 7. It also stimulated him to include a short exploration of the children's ideas relating to the trajectory of the missiles as he planned the next lesson for 15 June. In our final interview on 24 July he told me this had been something he had thought about earlier and was not just "off the cuff". He felt it might interest some of them, and would be an opportunity to talk with the class as a whole, and worth spending a little time on.

When I arrived on the morning of 15 June George discussed his plans while the class was in assembly. He told me that they would spend a few minutes at the start of the lesson exploring their ideas about the trajectory, but it was not central to his plans. This was the only planned piece of class teaching focussed on children's scientific concepts which I witnessed.

The main thrust of his plan for the day was in line with his long term aims for promoting skills and attitudes. He had adapted further ideas from the Science 5-13 sources to build on the activity of 12 June. He planned to review variables which might be identified and tested when aiming mangonels, to set the children to select those they wanted to test, and require

them to write a plan of how they would do this. His role would be to help them clarify their plans and get them to be more systematic. He also intended to improve their writing of conclusions.

11.5 Ideas and Investigations - the Lesson on 15 June

At the start of the lesson after lunchtime on 15 June George set the children the incidental task of drawing their picture of the trajectory of the missiles fired from a mangonel and adding a brief written explanation.

George: in other words what path does it take? OK
... so it flies up ... comes down again ...
and goes along a bit ... I wonder if you could
just draw that pathway for me ... and then in one
sentence ... or maybe two sentences just explain
why you think it does that ... if you can ...
does everyone understand that?
(Audiotape 15/6/84)

He provided some demonstrations, rephrased the instructions in several ways and answered questions before leaving them two minutes to do it, followed by a class discussion in which pupils reported and drew on the board.

As the children drew and wrote in their jotters George commented to me that most were producing symmetrical curves, although in a few drawings and some of their explanations variations in the missile's path or speed were tentatively suggested. Many used the term power. Rebecca's jotter for example showed the drawing and comment in figure 11.3.



I think that the pencil sharpener went over like this because of the power of the mangle. when it catapults. I think it goes up and then down because its power gets less and so it come back down.

Figure 11.3 Rebecca's jotter on 15 June

In the class discussion she volunteered her view.

Rebecca: Mr Packham ... I think it follows that path ... but I think ... errmm ... why it does it is because when the wood hits the elastic band it gives it power and when it gets ... about up to their ((she points to diagram on board))

George: Up to the top?

Rebecca: Yeh ... and then it starts ... and then it starts ... its power starts getting less and thats when it comes down/

George: Ri...ght...next

Rebecca: /because its not got any power to stay up in the air

George: mmhmm .. is it still travelling though? Its still got enough power to travel forward has it?

Pupil: No no

Rebecca: A little bit

George spent a little time drawing out other pupils' views and

the implications before ending with another demonstration in which the symmetrical trajectory was clearly silhouetted against the window. Despite his emphasis on this Dorothy, who had watched and waved her arm with the flight path, said quietly "it stopped at the top and went right down". This twenty minute interlude raised a number of ideas and issues which George and I pursued later. However at this point he set the main task for the afternoon, announcing "now the next stage" and seeking some ideas from the children, this time of variables they could identify and investigate. George reviewed others he had thought of, or taken from the published sources, illustrating some with pupils' models. He concluding by saying "there's some ideas that I've thought of ... I wonder what you can think of?"

When he was setting the task all the target pupils were looking elsewhere or handling their mangonels which were on their desks. The class was given ten minutes to talk about "what you're going to test and more importantly how you're going to find out" before jotting down their plans for him to check.

The plans jotted down by the children were mostly limited to general questions or lists of variables which were to be explored. George's consultations with individuals about their plans involved varying degrees of direction. With one boy he sought to ensure that he understood the term pivot and asked him to spell out his plan in more detail; with some pupils he simply confirmed the problem they had chosen. Dorothy and her partners,

Amanda and Deborah, had identified a general question concerning the effect of the size of missiles on their flight path. George had a long conversation with them, commenting "its a good idea ... but how will you do it?" They remained uncertain of how to translate it into an investigation and how to carry that out, and made little progress in the lesson. Danny had teamed up with Ivor, as Luke was away on holiday, and his jotting implied he had a plan to follow to investigate the height over which a catapult would fire from different ranges:

We could get one book and the catapult 10 cm from the book and if it makes it put one more book on and if it doesn't make it put the catapult 10 cm back (Danny's jotter 15/6/84)

When he discussed Danny's plan with him George sought clarification then extended it with an idea of his own.

George: so you want to find out . Danny

Danny: if it () got over the books

George: huhum "we could get over one book"/

Danny: then you could put if further up/ you could keep putting the books up and when it doesn't reach it move it 10 cm

George: ((reads out Danny's jotter slowly))
I don't quite know what you mean here Danny

Danny: ((explains how he plans to raise the height of a pile of books till the capapult cannot fire over it, move the catapult 10 cm further back and repeat the process))

George: so you're interested to see . what? What are you trying to find out by doing that?

Danny: errm ... how high the catapult would fling the (plasticine) over and how many () it would need to move back

George: huhum . and what will you keep the same?
Danny: same
George: same what?
Danny: same plasticine
George: so you might keep the plasticine the same
maybe . tell you what I'd be interested
in doing . if you could do what you said you'd
do
Danny: yeh
George: measure the distance from the book to
the catapult when it just goes over
Danny: yeh .. and then move it back
George: and then measure the distance which it
goes over and lands on the other side
Danny: yeh (quietly)

George went on to elaborate how this investigation might be developed to identify the mid point of a missile trajectory at which it was highest, and suggested Danny might try this although it could prove difficult.

Rebecca had jotted down two very brief suggestions for investigations:

1. how far it will go with a serton amount of (plasticine missile)
2. how many targets you can hit in a few shots
(Rebecca's jotter 15/6/84)

George asked Rebecca about her plans for pursuing those questions, and the variables she would investigate, before directing her to select just one of them.

George: How do you think you can find that out
- how many targets you can hit in a few shots?

Rebecca: get the piece of paper we've been using
and turn it over . and draw a new target

George: what will you change to try and hit it in
a few shots?

Rebecca: () changing the mangonel

George: just concentrate on the top one I think

By 2.15 pm George had checked all the children's jottings and had told them "OK ... begin to try it out." Rebecca and her partner Carol made a row of plasticine missiles and set up an extended firing range with two tables. They fired their mangonel from one toward the other, on which they built a 'wall' of books in front of their flat paper target. At playtime George told me that they seemed to be having difficulty getting down to testing but appeared to know what to test and how to do it. Rebecca came in to set up a ruler to help her measure and tested the accuracy of their mangonel at different distances. George visited Rebecca and Carol twice toward the end of the afternoon. The first time he helped them interpret their results, beginning by asking "Do you see any pattern coming out so far, Rebecca?" A little later he explored their views about the fairness of their test, when he asked whether it mattered if they fired the mangonel differently as they took turns. Rebecca replied "don't know" and despite George's suggestion that it might make a difference she maintained that she thought not, and he concluded "It can't make a difference? OK." Apart from this final interaction, where he probed her view of controlling a variable but did not influence

it, George's interventions with Rebecca had been more directive than in previous lessons.

When Rebecca had shown him the ideas in her jotter he had told her to "just concentrate on this top one" as noted above. She confirmed this when I interviewed her, saying "we just did first one because Mr P said just do that one as it probably would be more exciting than the other one". She explained this to me with reference to the jotter, saying they got their idea from "playing around" in the previous lesson - "so we wanted to find out if it was just the way we built the catapult or just the way ... or it was the plasticine". When telling me about their results they referred to the later intervention of George's.

we made 6 balls of plasticine all a little big bigger than each other. Then we put them on the mangonel and fired them three times our results are like this.

1	2	3	4	5	6
2m 35	2m 31	1m 19	1m 31	1m 31	1m 29
2m 35	2m 28	1m 59	1m 19	1m 30	1m 11
2m 46	2m 30	1m 19	1m 65	1m 27	1m 6

Figure 11.4 Rebecca's report on the results of her mangonel investigation

Rebecca: at first when we just did that we didn't know how to work the results out because we found that there .. most of them went down .. then as soon as we got to number four we got some peculiar results. So we weren't sure and then when Mr Packham told us to do the medians we saw that they all went down.
(Pupil Interviews 15/6/84)

Further evidence of the pupils' activities and ideas was available from their writing, completed by most on 20 June. On that day, following a further short talk about the forces involved in the trajectory, George had set them to write. He reported his instructions as follows -

I said something like "record how you made your mangonel. Do a diagram. Say where the power came from. What was the question you wanted to answer? Record results and try to use these to answer your questions."

Before this I returned to the idea of the trajectory and said they might like to include these ideas in their writing
(George's written note 20/6/84)

An extract from Rebecca's written record is shown in figure 11.4.

The tabulation of results had been Carol's idea and the medians which George had suggested were calculated in their jotters and used as the basis for a graph. Very little reference was made in the children's writing to their ideas on the trajectory, the exception being Mark who included in his report the following

The mangonel's power has up speed and forred speed and at the highest it gets the up speed has no power left and it still has some forred speed and then it gets the down speed and starts to go down but it has some forred speed and it still goes forred (Mark's writing 20/6/84)

11.6 The Siege - the Lesson of 21 June

For 21 June George had devised an investigation which would require the pupils to consider more than one variable and lead to a report written in a different style. After that he hoped to find time for some related creative writing on the same theme before moving on to work on bicycles, as the end of term was only three weeks away.

Some children were still writing up their reports when I arrived on the morning of 21st and encountered William at the workbench building an elaborate wooden model of a mangonel (figure 11.5)

William had been working consistently on this for a day and a half. He was a boy who normally achieved very little and George pointed out to me that in his previous class he had been judged to lack persistence. He was also socially isolated and George seized the opportunity to boost William's image in his own eyes and that of the class. After play he introduced the lesson with a demonstration of William's model which impressed the rest of the children. George then turned to set the new task in a historical context. The children were asked to imagine they were besieging a walled city defended by archers and needed to balance the advantages of firing their mangonels from close up against the danger from arrows. They were to test this out to scale, also varying the size of missiles using various wooden cubes.

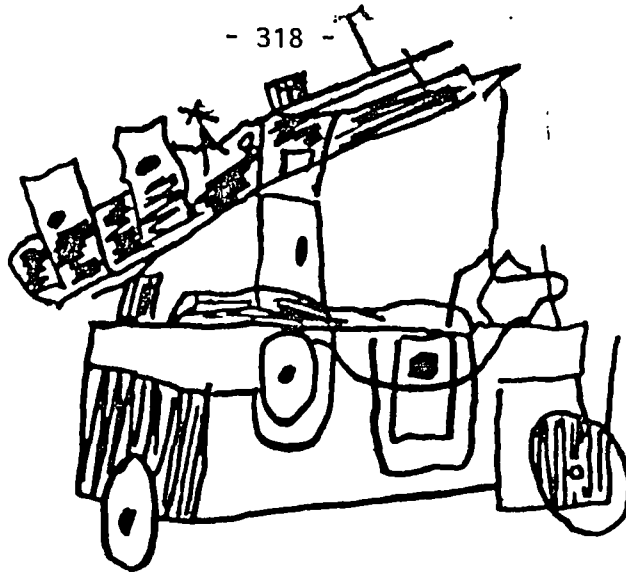

The mangonel is made out of woods and card and nails and plastic

It gose up and down and it gose to the side want you turn the angle

I wantd the mangonel to be high and I want a trigr and I want to meck it gow up and down.

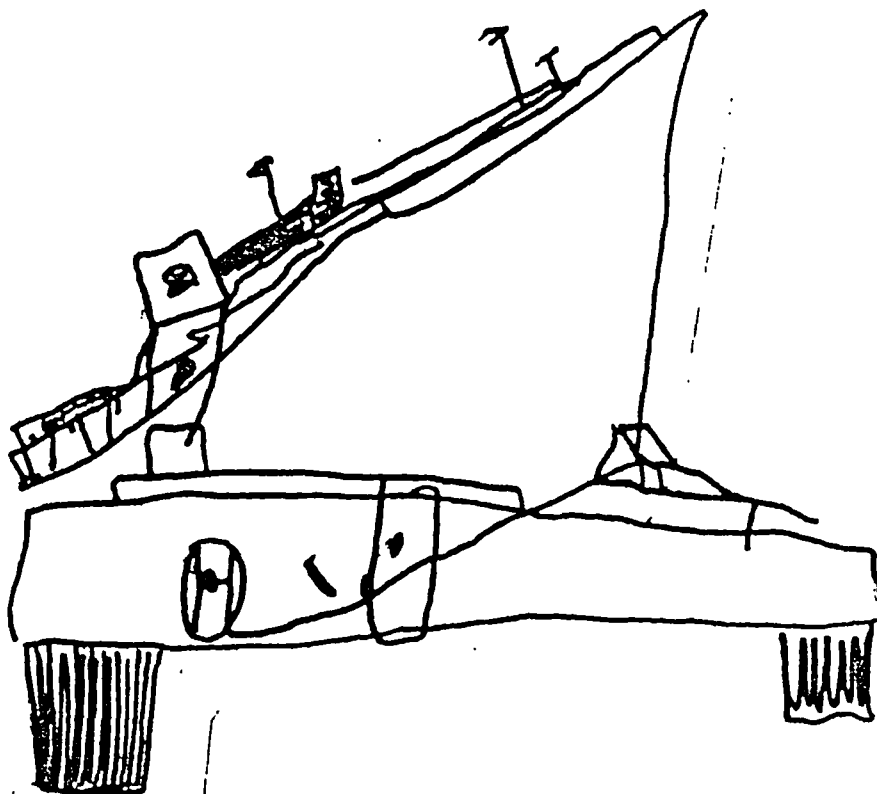

Figure 11.5 William's model (William's original drawing and writing processed for publication)

George had told me before the lesson that he would tell the children it was their responsibility to organise the activity and that he wanted results, intending to see how they got on. When Danny came to ask him what to do he said "it's up to you". While Luke was away on holiday Danny worked with Ivor. By lunchtime they had systematically investigated the effect of varying the distance and size of missiles on the accuracy and effects as they fired them at a simulated wall. Around the room groups were engaged in similar investigations, although not all with the same concentration or success.

After lunch George moved round the groups and I spent some time with Dorothy. She and her partner had been intermittently on task and messing around with a ruler and a stuffed bird from a display. She was able to explain the task very clearly and talk about changing the size of missile, angle of firing, and distance, but not to give any explicit or systematic account of controlling variables. As I squatted with them it served to remind me of how it felt to be the teacher rather than an observer; I noted that it seemed hectic and demanding at this stage. Many groups were making progress and George stopped the class to hear a report from one group which he then summarised. The class were then given ten minutes more for investigating. I felt he was hotting up the pace. When George later told them there were two minutes left he explained to me that he thought by now those pupils who were going to succeed at the task already

had, citing some examples.

Then he set the task of recording their findings in the form of a written report to a General, based on balancing the need to get close to a besieged wall against the danger from the enemy archers. He required them to include evidence to convince the General.

At 2.20 pm George gathered the class to hear some reports on their findings and conclusions. He then explored pupils' ideas on the effect and impact of using heavier missiles or firing at closer range before the lesson finished for playtime. Some pupils chose to complete their writing after play, others did so subsequently. George commented to me that he was reasonably pleased with the children's grasp of a difficult task, and felt any difficulties they experienced had been in organising their investigations.

When he came to look at their writing up later on to make further assessments of their learning he reported "I'm quite pleased with it; even those who didn't manage to knock down the wall had made something of it when writing up". He told me this over the telephone on 27 June. Two examples of pupils writing are shown in figures 11.6 and 11.7.

This condensed account has aimed to convey the flavour of the busy siege lesson and include references to the wider concerns of

22nd June.

Dear General.

I think that you should move your mangonel to 150 meters because if you move it to 50 metres you will hit the wall but the archers will kill a lot of men. And if you put it at 200 meters the archers will not kill any men but you will not hit the castle wall so my opinion is that you should put the mangonel at 150 meters. I think that you should put the mangonel at 150 meters because you will be able to hit the wall with out the archers killing any one. If you fire the stone at a near point you could hit the wall better because the stone has more power than further away because if a small stone was travelling from a long way and it made it to the wall it would not do much to it because it would not have much power and if a big stone was travelling from about 150m it would knock all the wall down because it had a lot of power.

Yours Sincerely Susan

Figure 11.6 Susan's written 'report to the General'

To the General

General the tests on our mangonel were very good we only had missed once out of twelve tests and that was from 2 metres. With in real life means 200 metres because we are testing a toy mangonel. Medium is the best size of rock because if you go near you would try to try a big stone because it would not reach far away. But the archers are very deadly. Still the big rock is the most powerful one.

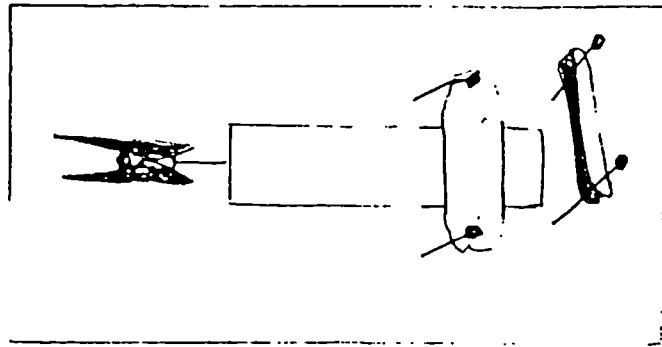

Yours Sincerely
Steven

Figure 11.7 Steven's written 'report to the General'

a class teacher, eg for socialisation and for curriculum integration. There was progression from the previous lesson - the task was more open, complex and demanding. George managed time and interventions rather differently. The writing task illustrated a different way of recording. Over the mangonel unit the emphasis on recording had grown. Generally however over the unit George had followed his stated strategy of reducing the stress on written products. His focus was on promoting pupils' responsibility for their learning, and extending their skills of scientific investigation. In the final mangonel lesson he reintroduced design and problem solving.

11.7 Making Remote Controls - a Problem Solving Brief for 2 July

The final task in the mangonel unit had been introduced by George on Thursday 28 June but there had been no time to pursue it till 2 July. He had devised a problem which shifted the emphasis back to designing and making. At the beginning of the afternoon on 2 July he re-introduced the idea of making a remote control for their mangonels. It was set as a problem to be solved within a time limit and using limited materials, which he had listed on the board:

pins	elastic band
card	thread
glue	wood
nail	

After demonstrating how William had already added a remote control to his model he reminded them of the task: "We discussed

.. on Thursday .. we discussed how we could make a special device for remote control of the mangonel." He went on to elaborate on this more than he had planned, telling me later he had realised once he started that it was necessary "to get the idea juices flowing" as he had not done much last week besides talk about it and he now sensed there was little carry over from that. He summarised two separate aspects of the problem: a method of pulling down the mangonel's arm and a catch or release mechanism. He stressed the need for them to form a clear idea and to take time to think rather than trying the first thing that came to mind or hand. Question and answer were used to clarify the task and keep attention; I noted that Dorothy seem intent on the setting of this task.

Within twenty minutes all the pupils were busy. Danny worked with Ivor again although Luke was back and was the first to talk with George. Then Rebecca discussed her plan and problems before starting work with Carol. Dorothy sought help to take her mangonel apart and George noticed her idea of using two pins which would be pulled apart by string as a release mechanism. She and Deborah had wound the string round dowelling as a pulley. George showed me another pupils' earlier work as a possible source of this. I noted that the children seemed to be pursuing their own ideas, and a range of solutions was being tried.

At 2.20 pm George told the class there were "only eight minutes before playtime" and talked to me of their progress and of what

he saw as an "increased sense of urgency". Dorothy and some others worked on through play and George visited her asking "It works?" to which she said "Yeah" and demonstrated. He applauded and praised her. She showed other children before going out to play. After playtime, when he arranged a brief class session, she volunteered to demonstrate how her mechanism worked, described the origin of the ideas and noted how George's only help had been to drill a hole. Her string now passed from the release mechanism, round her improvised pulley, and down through the hole to be operated at a distance.

Other pupils were having successes, including Rebecca and Carol who explained to me how they improved their design, incorporating George's suggestions, and the stages they went through. I noted the timing of his interventions and the way these had helped them evolve their own ideas and cope with the complications of designing and making. When they called him at 3.10 pm to show the result in action he commented "It's brilliant". Shortly after that he asked the class to tidy up and today they did so promptly, leaving time for a short class demonstration in which Rebecca featured.

My impression of this lesson was that it had been more successful for pupils and less hectic for George than many previous ones. He agreed, commenting at the end of the day on 2 July that he had felt relaxed and able to look round to see where he was needed and then intervene appropriately. He suggested the reasons for

this included the pupils' familiarity with the materials and their learning from previous mistakes; they did not have to harass him so he was relaxed enough to make interventions deliberately. He added that chance was of course often involved.

Rebecca and Carol had previously mentioned how they were learning from mistakes when I interviewed them on 15 June. They had been talking then of their earlier difficulties with the vehicles. In a later interview Rebecca would elaborate on that view with specific reference to this final task with the mangonel.

Rebecca: that mangonel . when we had to get a way
of automatically doing it . that were good cause
you had to think about it and then try it out and
if you did it wrong . you . you got . you learnt
by doing it wrong.
(Pupil interview 13/7/84)

In our final interview three weeks after this lesson George commented on the successes of this unit. He commented that he would have liked more time on it as it had worked well; he contrasted Rebecca's progress with her early work on vehicles, noting her group's success and their organised workmanlike approach in this unit. He cited Dorothy's development of her control mechanism as an example of her pursuing her own idea and executing it with little need of help. He generalised from this example.

George: It was one of those things actually that
bears out some of the things I've been thinking
about the project .. she'd half done the task
I felt it wasn't completed but she was so pleased
by that part that she wanted to just test it
out a lot and that seemed to be enough

for her at the time .. and I think that will mean a lot more to her than if I'd said "this is the task and you must complete it" .. the fact that she had effectively done it herself (Interview 24/7/84)

11.8 Discussion of the Analysis of George's Thinking

The analysis of this unit confirms and extends the picture of George's thinking and raises some further issues in primary science. The learning and teaching of scientific investigations in a primary classroom has been the major theme.

11.8.1 Planning

Movement between layers in the internal structure of planning thoughts occurred as George's images of the flow of activity were focussed on lessons. He referred to broader goals, longer term plans and the shape and pace of the unit as well as to immediate teaching plans. Other sources of ideas were used creatively to enrich the teaching and George's repertoire. Rather than closely following published curriculum materials, or directly adopting their techniques and ideas, George adapted them in an extended process of thinking and practical trial. The translation of those ideas into tasks was related to George's dilemmas over skills teaching and time in the lesson of 12 June. Analysis of those dilemmas shows connections between his plans, thinking in lessons and more general theories, for example in his choice of the opening task and the pacing of the unit.

The pattern of this and earlier units of activity reflected his handling of a dilemma over the need for distinctive scientific and technological skills to be learnt within the context of a real problem. He believed that skills teaching should be in response to the need of particular pupils, but recognised difficulties in ensuring pupils learnt the range of skills a task might require. In the circumstances of the present topic his strategy for managing this dilemma was to begin each unit with a task which restricted the construction demands and emphasised scientific investigations. The later lessons incorporated craft and design in more open-ended problems. When these proved too frustrating, and under-productive for his underlying goals of promoting inquiry learning, he retrenched to a more directive task in a new activity. Throughout he sought to teach attitudes, skills and ideas in context but took some incidental opportunities for more direct teaching.

This dilemma over skills was linked to that over the use of time which was also addressed at the planning stage when he considered how long tasks might take and how to pace them. The management of time was most evident in lessons. The provision of more time for an exploratory stage on 12 June was an adjustment prompted by reflecting on the task in the light of his theories, as it had also been on 14 May. Such decisions made during lessons were not simply responses to problems or discrepancies between image and reality but involved other aspects of his thinking. In this case it had involved his ability to analyse the task drawing on his

knowledge of scientific processes and his underlying views of learning. The importance of play, experience and activity featured prominently in those views.

11.8.2 Teachers' Thinking-in-Action and Pupils' Investigations

The term thinking-in-action was adopted in the last chapter as the evidence showed that thinking during lessons involved more than decisions or responses to pupils. The example from 12 June illustrates how analysis of his dilemmas reveals complex links between George's thinking in lessons and his theories and plans. His postactive thought can also be related to his interactive thinking in the analysis of his dilemma over interventions. In his own written evaluation of the lesson George had refined his view of that dilemma, noting that there was no conflict between his original aim of letting pupils try out their own ideas and his concern to make them look more critically at their results. In the rest of the lessons of this unit George was seen to intervene and interact with pupils in a variety of ways as he managed his dilemmas over skill teaching and interventions.

On 15 June George was seen distinguishing different subskills in investigations, from the identification of testable questions through to the interpretation of results. He individualised his interactions and varied his interventions as he applied the general principle expressed in the previous unit of "where

they've got ideas .. don't do much except help them in their own clarifying . where there are materials or skills be quite prescriptive." Much of his interaction with pupils was concerned with the identification and control of variables. The lesson was planned to help them do this more thoroughly and systematically. The pupils' initial plans were generally expressed as ideas to explore or actions to carry out, rather than a controlled experiment. However their responses to the task varied as did George's interventions. With some pupils he was heard simply seeking clarification, in other cases he probed their plan and asked about the variables they were investigating and controlling. In Danny's case he added his own suggestion, partly it seemed to develop Danny's plan but partly to link it with the earlier teaching of ideas connected with the missile's trajectory. His interactions with Rebecca on 15 June began with a clear direction to choose one investigation, proceeded to guide her interpretation of results, and finished by probing her views on controlling the way they fired their mangonel.

These examples illustrate some discrepancies between the model of scientific experimentation which a teacher seeks to promote and the way his pupils approach investigations. However there is more to be said than that children simply do not work like scientists. Clearly they differ in the extent to which they identify variables and learn to control them. Teachers such as George are inducting them into those ways. They have to decide how far and how fast to go, and how to individualise their

teaching. They have to decide when to teach the skills as pupils investigate their own questions, as on 15 June, and when to limit the variables in more closely defined tasks, like the siege on 21 June, where pupils such as Dorothy still had difficulty organising the control of variables although they could identify them and take them into account in writing a report. These decisions are not made in isolation. Other matters have to be considered, for example dilemmas over process and content or products. Classes and lessons have to be managed. George's management of interventions during the lesson was an illustration of his practical integration of elements that have been distinguished for the purpose of analysis, eg:

his beliefs, theories and pedagogic knowledge,
his goals, long term plans and strategies,
his purposes for particular tasks,
his images of lessons,
his individualisation of interactions,
his pupils' mediation of tasks,
his evaluations of his own performance and the progress of pupils.

George's thinking-in-action combined many of these in the course of managing an active science lesson. It prompted reflection that was not restricted to the action, or even to the longer term plans, but led to restructuring of his repertoire and theories. This was suggested in earlier chapters, for instance when George

began to reconsider his views on design and skills teaching. In the mangonel lessons he distinguished more clearly his teaching of aspects of scientific investigation and design. His interventions were also adjusted in the light of earlier reflection on the dilemma. He responded to pupils' ideas by exploring them and reviewing his views on the learning and teaching of scientific concepts in primary school.

11.8.3 Teachers' Theories and Children's Ideas

The lesson of 15 June and associated data provided insights into George's theories concerning the teaching of scientific ideas to primary pupils.

There was a short piece of teaching concentrated on children's scientific concepts. This contrasted with the incidental, unplanned teaching of ideas at other times. George did return briefly to the idea of the trajectory when he asked the children to write up investigations on 20 June, but he made limited use of the particular insights and explanations in his subsequent teaching. However it had sparked off the articulation of his views on how children's scientific ideas are constructed, and how his own knowledge of science could be used. It also illustrated that investigations provide opportunities to explore related concepts but the underlying ideas may be complex. When George looked back at the end of term in the interview on 24 July he judged that the concepts involved had been too abstract and

difficult for most of the pupils. Their comments and writing on the 15th contained a range of terms and ideas which were not always consistent with one another or with observations.

George's explanations on the 15th and 20th, in which he talked of speed and force in two directions, were largely rejected. Only Mark chose to refer to the ideas in writing up on the 20th and he appeared to have compounded his own explanation in terms of power with George's discussions of speed and forces.

That lesson on trajectories stimulated George to elaborate his views about how children learn scientific concepts and the implications for his teaching. This was developed in his practice and an accompanying dialogue during this unit which raised important questions in primary science. The emphasis on process, with the incorporation of problem-solving, was representative of the general trend in primary science. Where George had taught concepts it had been either incidental and individualised or closely tied to the investigation. The role of experience and discussion, the individual and uneven learning of concepts, and the value of predicting and testing ideas had been implicit in his practice. In this unit he was stimulated to make them explicit and consider such thorny questions as how he could usefully teach any coherent set of ideas (in his terms would they be just a "lucky bag" or become a "patchwork quilt"?). The teaching, and pupils' responses, also indicate challenges for teachers of primary science if scientific concepts are to be taught more actively, rather than caught incidentally in the

course of activities emphasising skills. Teachers will need a sound grasp of scientific ideas themselves or support in this area, and a theory of how concepts are learnt on which to base their practice. George had the former, but still reported difficulties exploring the ideas with a class of ten year olds! His review of the latter in this unit was stimulated by interactions with pupils and sustained by the opportunity to discuss it and apply it in practice. Professional development requires such stimulus and support:

in order to broaden and deepen their capacity for reflection-in-action, professional practitioners must discover and restructure the interpersonal theories of action which they bring to their professional lives. (Schon, 1983, p353)

Involvement in a collaborative study such as this may provide the conditions for that restructuring, as was witnessed in the present case.

CHAPTER 12 CHOICES

12.1 Introduction and Overview

Although the work on mangonels described in the last chapter was successful in George's eyes there were other activities which he had not yet used and the end of term was approaching. One of these had been briefly introduced late in June when he had talked with the class about investigations with bicycles. He intended to start that on 10 July as the final activity in the topic. As the lesson approached he decided a more open choice was appropriate at this stage. So, in addition to the opportunity to devise tests of their own using bicycles, the children were free to choose to extend their work with mangonels, return to powering their uphill vehicles, or to negotiate other activities. The children assumed considerable responsibility for their own learning, and work begun on 10 July was continued at various times, especially on 13 July.

Table 12.1 outlines the sequence of the action and the data. The account of the action in this chapter is based largely on my observation on 10 July. George's plans and evaluations were reported in conversations and at our final interview on 24 July, after the term had ended. I had also interviewed pupils, made my final collection of copies of their work, and arranged feedback and clearance with all those involved.

TABLE 12.1 OUTLINE OF THE ACTION AND DATA IN 'CHOICES'

<u>Date</u>	<u>Action and Comment</u>	<u>Data</u>
10 July	Lesson when pupils chose activities, including new investigations with bicycles	Fieldnotes
13 July	Second 'Choices' lesson Teachers comments Interviews with pupils	Fieldnotes Written note Audiotape
19 July	My final visit to school Interviews and feedback with pupils completed	Written note Pupils' work
20 July	Telephone call to headteacher	Written note
27 July	Final interview with Teacher after end of term	Audiotape and note

12.2 George's Planning

As noted in previous chapters investigations with bicycles had been in George's earliest plans for the topic and were mentioned at intervals through the summer. He had introduced the idea to the class on 28 June but there was no time to pursue it till 10 July. From his comments when he told me his plans over the telephone on 27 June I expected to find all the pupils involved in tests with bicycles in the lesson on 10 July. By then however George had decided to give the children a wider range of choices, for a number of reasons which he volunteered to me during the morning. The constraints of time increasingly influenced his planning as the end of the school year approached. He commented that "some children had work to complete. They might want to continue or fit in activities. There was only a week and a half left in the year." More generally it was a further application of his stated strategies, combining freedom of choice with time to pursue their own ideas in "a whole morning for them to choose and persist." And above all it was consistent with his long term goals of making his pupils responsible for their own learning, offering "a more real choice than say asking them to all do their own bicycle test .. and so a progression in terms of their own ideas."

12.3 Choices - Setting the Task on 10 July

At 9.00 George checked the register and announced to the class that they would have all morning to pursue activities of their own choosing, apart from half an hour of hymn singing with the rest of the school. He pointed out that they must think first what they wanted to do and then stick at it rather than chopping and changing around. Then he told them they could choose one of the following:

continuing their current writing about insect larvae;

painting;

maths;

perfecting mangonel mechanisms - but not testing them today;

bicycle activities - for which he had cards of his own to

supplement their own tests that they should plan and have checked by him;

any other activity - after his agreement.

12.4 The Lesson on 10 July - the Action

Many children quickly selected an activity from the list or carried on with a task they had begun before. Dorothy went out with another girl to draw the caretaker's bungalow. Rebecca wandered around and wondered what to do. Eventually she came to ask George if she could use one of his workcards. When he said that she was at liberty to do so but really needed a partner for the tasks she replied that she had no-one to work with. Looking unsure she went to the book corner where she joined Carol in

consulting reference books on plants. By 9.30 she was involved in some related work on plants. Luke had brought his bike to test and at first asked George if he could work from one of his cards. George asked "haven't you designed your own test yet?" and when Luke said yes, George replied "well you don't need my cards do you?"

George later pointed out to me that his workcard and Luke's own personal investigation were very similar. In his jotter Luke had merely noted:

Bikes

We are going to see how far it takes us to stop from different runs. (Luke's jotter 10/7/84)

After his conversation with George he went briefly around the classroom before organising his materials to carry out this investigation. Danny had joined him by then, after initially starting to adapt a model vehicle with Ivor, his partner during Luke's absence. By 9.30 am they were outside, as were several other children and George, who had just directed two girls needing more space to the field at the end of the playground. In anticipation of the investigations a dozen or so children had brought bicycles to school and the continuing fine weather provided an ideal opportunity for these outdoor activities. The class was widely spread out and involved in a variety of tasks which George monitored as he circulated outside and in the classroom.

Inside the classroom most of the children worked on their chosen activities in small groups. A few worked on their own, for example William and Ivor who continued construction on their vehicles. The model makers moved back and forth between their desks and the workbenches in the corridor. A few children were still finishing maths or written work. One or two had switched activities, some as they completed tasks and others without finishing what they had begun.

They continued after a break between 10.00 and 11.00 am for hymn singing and playtime. Danny and Luke recorded and discussed their predicted and measured braking distances as they took progressively longer runs on Luke's bike. Variations of surface and occasional skids gave them some excitement and were cited as variables when they were explaining their results. Other bicycle investigations were proceeding; the two girls George had sent onto the field were now enthusiastically timing and measuring. Their group grew and by 11.30 am Luke and Danny joined them, and I returned to the classroom.

In the classroom the pattern was of small groups and individuals, some mobile and others settled and concentrating intensely. Rebecca and her companions, having painted flowers, became interested in the water inhabited by the insect larvae that the class had previously observed and written about. This led them to ideas about comparing that water, which was murky, with clear-looking tap water as a habitat. They discussed this with

George as they stood by the display of larvae and microscope he had made.

George volunteered some of his own impressions of the lesson to me as he gathered the class together in the last five minutes before lunch. We had just joined with all the pupils in the classroom to watch Ivor's vehicle run round the room powered by an electric motor. Ivor had been the only one to follow up the suggestion of using pulleys which George had made several times. As George talked to me he wondered why that was and suddenly recalled a short conversation with Ivor at what he now assumed must have been a crucial stage. Such insights can be gained in the midst of a busy lesson but there is rarely time to build on them immediately. George had only a few minutes left to ensure every one was back in the room ready for the afternoon's work. Later he would be on playground duty and end his day with a parents' evening. As the 'cyclists' returned they reported their findings and their wish to complete the investigations later, but not to write about them. George told me that he felt Luke and Danny, and the two girls, had done useful work but the other boys had made less of the opportunity. This he attributed partly to the tasks they chose and partly to the composition of their groups.

The work was adjourned for two days during which the class all went on a walk by a local canal and did follow-up work. After my last visit to the staffroom I arranged to return on the 13th.

12.5 13 July - My Last Visit

For the afternoon of the 13th George planned that the pupils should complete any writing from the canal visit and continue with 'choices'. At 1.00 pm he announced this to the class and told them that if they wanted to do experiments with bicycles or model cars they should first show him their progress. Many more children than on the 10th chose to return to the problem of powering vehicles, deferred from their uphill struggles five weeks previously. George thought they had been stimulated to this by seeing Ivor and Duncan demonstrate their vehicles in assembly. In this last lesson there were many examples of pupils getting inspiration from, or consulting, peers rather than George.

Dorothy however sought George's advice when she completed her writing around 1.35 pm and began to develop a model vehicle. She became engrossed and declined to be interviewed when the time came. The other target pupils took their turn, following Mark who volunteered to have a chat first. Danny was more relaxed by now but Luke was still nervous. The two boys were again working together on a vehicle but came separately to the adjacent office for the interviews. Rebecca was writing but more than willing to talk, bringing Natalie along with her for company.

I managed to talk with Dorothy on 19 July when I made my final visit to show the children a hurriedly edited videotape of the term's activities, ensuring that they all saw themselves in action. So all the class, and each of the target pupils individually, had a final chance to express their views and receive my thanks. I arranged to gather George's evaluations in an interview at my house after the term ended. I made my farewells to the class, who would themselves be joining another teacher with a different style and set of priorities after the summer holidays. The headteacher was out so I telephoned the following day to formally thank him and confirm the arrangements for clearance of material from my term in his school.

12.6 Discussion and Evaluations

Some detail of the end of the term, and particularly the lesson on 10 July, has been given to convey the flavour of this last stage of the topic. The activities of those involved in the study - George, his pupils, and myself - have been described to complete the story. This final section draws on that account and some evaluations to extend the discussion in previous chapters. It focusses on postactive thinking which has been less systematically analysed to date. The interpretation of George's views on teaching scientific concepts is also extended.

In this last stage of the topic George had come to a decision

which illustrated the movement between layers of the planning process even after he had selected an activity and formed an image of a lesson. He had cited a number of layers when explaining his reasons for changing his plan. It was not simply a matter of choosing between immediate constraints of time or longer term goals, but of considering means and ends and situation together to create a more appropriate plan. Preactive thinking did involve the selection of activities from his repertoire, adapting them and forming images of how they would be realised over time. In this case the bicycle activity was well established in his repertoire and he had sets of workcards which he had developed over the years as he taught it. However he brought his experience to bear on the new situation not as a recipe to follow but rather as a reservoir on which to draw.

Postactive thinking was illustrated in George's comments after the lesson on 10 July and probed more directly at interview on 24 July. His assessments of pupils' progress and of his teaching were related to his overall aims and strategies. His postactive picture of the flow of activity mirrored that envisaged in his planning.

George: I think what I tried to do was . my main feeling was that I wanted to give them extended projects interspersed with smaller ones . that's really been . the . main criterion.
(Interview 24/7/84)

He explained that by projects he meant the activities which he had selected, listing them as 'downhill', 'uphill', 'mangonels

and modified mangonels', and finally 'bikes'. Reflecting on the use of individual elements he remarked that he had been right to adjourn the 'uphill struggle' and "in fact probably I ought to have done it the lesson before that .. I'd seen the seeds of disaster". He would have liked to have spent a bit more time on mangonels and he volunteered some further investigations that could have been done with them. It was not simply that individual activities had been underdeveloped or neglected for lack of time but that he felt the structure and growth of such a topic required time and continuity.

George: I think over the years I've come to realise that in fact that sort of project is over a long term ... so they . so they sustain their interest .. actually their interest builds if you do it reasonably well .. they become more . more expert . they become more interested.
(Interview 24/7/84)

He was satisfied that his provision of time for pupils to pursue their ideas in lessons had worked well and pupils' views on this seemed to match his. Mark had put it succinctly when he volunteered to be interviewed on 13 July, saying "I like long sessions on things so I can get it done." Rebecca elaborated her initial answer that they had enough time by referring to the value of opportunities to plan and try out ideas. She noted the tension between the motivation of being given time and responsibility for using it on the one hand, and on the other the temptation to take one's time when the pressure was off. In passing she remarked "when you're enjoying yourself or doing a lot of work time passes ever so quickly." In the lesson on 10

July she had again shown an initial uncertainty over what to do and eventually chosen not to pursue any of the activities from the topic, although at interview she spoke positively about the challenges it had provided. She described it as "more kind of enjoyable . well it is sometimes but it takes more thinking."

George's assessment of her progress was related to his broad aim of promoting independent inquiry and pupils' responsibility for their own learning. He contrasted her approach at the start, when he felt that "if you gave her a task to do she'd do it so long as she knew what she was supposed to be doing", with her later success during the mangonel activity, which he cited as an example of how he felt "she was beginning to see that she could go it alone". His view of Dorothy's success in the last mangonel unit, expressed in this same interview, has already been quoted in Chapter 11. To illustrate his assessment that Luke and Danny had made great progress he referred to the bicycle activity they had carried out:

George: I did feel they were very excited and they really knew exactly what they wanted to do . exactly how they wanted to do it . and just did it and they did their measurements very keenly and they had no false starts to it and they had their own ideas . it was very impressive
(Interview 24/7/84)

In George's evaluations of his own teaching he was critical of two aspects: his interventions and his class discussions. He referred to his dilemma over interventions, recalling the 'uphill struggles'; he now judged he should have been more prepared and directive:

George: because I wasn't in any way being . being directive enough . so they didn't succeed in making sturdy enough vehicles to begin with . for them . I don't think I'd researched myself the possible power sources / because . with probably the best of motives . that I'd wanted them to discover for themselves and me not to know the answer first / there I was being a bit stand-offish (Interview 24/7/84)

George's resolution of this dilemma in his subsequent practice was discussed in Chapter 11. The introduction of practical problem-solving presents teachers with particularly acute forms of general dilemmas over their roles and the balance of discussion and activity in children's scientific learning. George was critical of his own handling of class discussions as noted earlier in the study. At the final interview he extended this to a general criticism of his class teaching sessions, which he felt had been restricted by his emphasis on providing extended time for pupils' activities. He said that he normally planned his lesson introductions carefully and felt they were something he did well; in retrospect he thought he might therefore have taken them for granted and improvised too much without thinking about their purpose.

George also regretted that he had not had time to teach more about structures, as he originally planned to do. He felt he had taught about friction incidentally and that the children's experiences were a basis for a later understanding, although they had not acquired any "general idea or theory" of frictional force. He went on to suggest the pupils had acquired an

understanding of the occurrence and effects of friction in various situations which they could apply in new contexts and would later incorporate into their learning in secondary school. His remarks were consistent with the more elaborated account of his views on the teaching of scientific concepts which he had given at the half term interview:

yes I'd think I'd only point to the fact that they've had opportunity to meet with it in a practical sense ... and have either overcome it or lessened it .. or they've increased it where they've needed it .. so not had a lesson where friction is our friend and friction is our enemy kind of thing .. but well they've done that practically .. they may not have got it all sussed out in nice compartments in their mind just what they've done but when it comes to doing it in say second year physics it will be clear to them when the teacher talks in those terms that this is what they've been doing and I don't see that its my job in a primary school to systematically teach science .. I see its my job to give them a wide range of experiences which will enable them to make sense of science with a big S, later on ... cause that's .. I don't think that's what primary science is about .. not teaching discrete packets of knowledge to make .. you know .. really good bits of cloth .. but in the case of someone like Dorothy they just ... give her an idea about these varying various lines various bits of the world which just wouldn't make sense otherwise .. but then later on as she gets more mature and older for her to be able to relate back to the experiences she's had here (to stick together) .. I couldn't give you a check list of the things they would have learned and the things I've intended to teach .. but I could say the things which I've stated along the line .. given them experience of (Interview 27/5/84)

In that statement George emphasised the provision of experiences rather than the systematic teaching of concepts. These were however seen as a basis for the personal construction of a more coherent and conventional framework of ideas as the children went through their scientific education. There is a tension between continuity of learning and the contrast of primary and secondary teaching in George's statement. The stress on process learning

in primary science was explicitly represented from the start in the present case. It had been subsumed under his general view of learning and his aims for the class when he set up the frame within which they were working for the year. Now, at the end of the year, he had offered choices to the pupils which were opportunities for them to work in the way he had envisaged at the start.

He was already incorporating the year's practice into anticipated practice in another setting. At the interview on 27 July he looked ahead, reflecting on how he would improve it and adapt it. He said he was not certain, but thought he would probably do the topic more selectively and thoroughly. He noted that in different circumstances he would alter the approach, for instance were he to do it in his new school next year he might integrate it more with the rest of the curriculum.

This account has portrayed just one sequence of a teachers' practice, tracing the relationships in his thought and action. It was situated from the start in its setting and time. In the picture of reflective practice which has been painted thinking can move back and forth in time, and be tested in real or imagined action. In this way experience can be brought to bear on unique circumstances, and be enriched in the process. This study has analysed one instance of this. In the next chapter the original working model is revisited in the light of the analysis.

CHAPTER 13 ON REFLECTION. MODELS REVISITED

13.1 Introduction

The previous chapters have provided a detailed analysis of one case of thinking and action by a primary teacher. In the light of that account this chapter revisits specific features of the models used in this study, and general issues concerning models of teachers' thinking.

The review of literature identified the variety of models and theoretical positions used in researching the field. It noted the move from models which represented teachers as decision-makers or limited processors of information toward models in which they are viewed as reflective professionals making sense of the world and testing their personal theories in action. The picture developed by Schon (1983, 1987) from close observation of the practice of experienced professionals has been adopted by other researchers to represent the interweaving of teachers' thoughts and actions (eg Anning, 1988). It was seen as particularly relevant to the present study. In Schon's model of reflective practice thought and action are closely related at several levels, from the thinking or knowledge that is implicit in the skilled actions of experienced practitioners to explicit reflection on action. Central to his account is the notion of reflection-in-action through which practitioners draw upon their

repertoire of examples, images, understandings and actions to bring past experience to bear upon new situations.

Reflection-in-action involves consideration of both ends and means, and recognises the uncertainty and conflicts of value which characterise practice. This seems promising as a model of how experienced teachers may approach the unique situations in which they work but needs to be examined in studies of actual teaching practice. In this case the detailed analysis of one teacher's thinking was compared with Schon's general model of reflective practice, and in particular with his concept of reflection-in-action.

To organise the study a descriptive framework specific to the field of teachers' thinking was adopted and developed into a working model. This identified three aspects of a teacher's thinking, referred to as theories, planning and thinking-in-action. The study analysed the internal structure of these and their relationships with one another and with features of the situation. Figure 13.1 recalls the representation of the elements and relationships which served as a framework for the analysis. The development of that analysis can be traced through the discussions in Chapters 6 to 12. It is consolidated and generalised in this chapter, which examines the elements in turn and then discusses their relationships. These are summarised in a modified representation in figure 13.2.

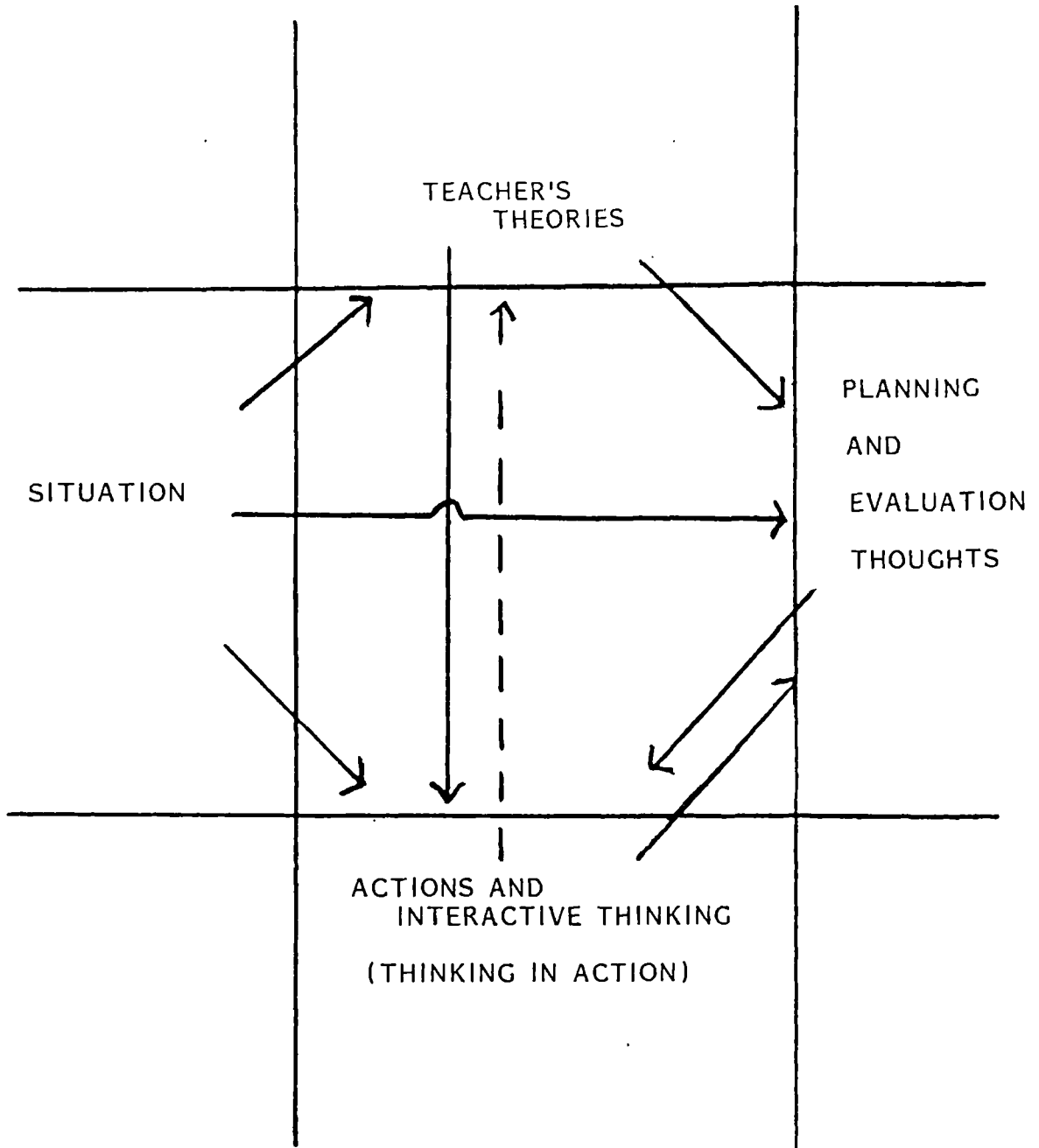

Figure 13.1 Headings and relationships in the original framework used in analysis (cf chapter 4, figure 4.3)

13.2 The Situation

This heading subsumed the general socio-historical context, the teacher's position as a primary class teacher with experience of science education, particulars of the setting and the people involved in the study. Details of these were necessary not only to locate the case but also to trace influences on the teacher's thinking. It proved possible to do this and, to some extent, to distinguish the relationships between different features of the situation and the three aspects of thinking. This was summarised in Chapter 6 and developed in subsequent chapters. For example situational factors relating to the teacher's career were seen to influence his theories, and also to colour his planning. The experience of being a class teacher within a particular primary tradition was related to his theories and plans, illustrating how the shared assumptions of school practices and educational ideology may influence the thinking of individual teachers.

For a proper understanding of the significance of a teacher's thoughts and actions it is necessary to see them in their psychological and social context. This requires analysis of the foreground of unique situations of practice and the more general background which is shared with other teachers. Practice appears to be highly situation-specific but this does not mean it is completely idiosyncratic and that no transfer or general insights are possible from studies of individual teachers' thinking. On the contrary, the interaction of personal characteristics and circumstances with the social and historical climate can be

examined in case study which provides an opportunity to relate micro and macro analysis. In this case not only was it possible to see how particular opportunities and constraints related to the teacher's theories and experience but the specific instance can also be set against more general educational developments. For example the teacher's autonomy over curriculum decisions and his commitment to an experiential approach was located in time and place, and reference was made to the shifting political climate which was beginning to change the control and emphasis of the curriculum.

13.3 A Teacher's Theories

The literature review revealed a variety of ways in which those aspects of teachers' thinking referred to as their theories were defined and conceptualised. In this study the heading included the teacher's general pedagogical and subject knowledge with his associated beliefs, drawing upon personal experience and values.

This teacher's knowledge of science teaching was based on his own scientific education and a year's work in a secondary school, as well as his experience in primary education. That knowledge-base consisted of a store of teaching approaches and activities, which he referred to in our first interview as his repertoire, and his underlying understanding of scientific processes and concepts. He was able to articulate how he drew upon those, although he preferred to regard them as internalised in an implicit

framework. He illustrated alternative ways in which he could use his knowledge to suit his aims and the situation - for instance in different approaches to planning termly topics or to teaching about friction. The views he held about children and learning emerged as major influences on his use of that knowledge. The learning of skills and attitudes featured strongly in the teacher's views about primary science. He saw concept learning as based on a wide range of experiences, and the direct teaching of scientific concepts as more appropriate in secondary schools than in primary. The teacher's more general theories of children's learning emphasised the importance of experience, individual differences, and the need for active learning by pupils and the application of their knowledge. These beliefs were consistent with an ideology of primary education which was associated with Piagetian psychology. Although the teacher was in sympathy with this he did not accept it uncritically, and during the study he was seen to examine some of his theories about learning and teaching. For example he elaborated his views of the role of the teacher as he explored his dilemma over the teaching of skills, and reflected on the teaching of concepts. His theory of how children learn science was not simply developmental or empiricist, and teachers were seen as having more to do than just creating opportunities for individual pupils to acquire skills and providing experiences from which they would construct their understanding. For instance in talking about his role in promoting children's scientific understanding he said during one lunchtime conversation that he was "in the business of

giving them experiences and they may form a pattern out of it", that "ideas and experiences should fit together over time and form a foundation" and that he would "help those ready to make connections and individual differences required individualised treatment of this". He had also suggested that in contrast in secondary science teaching it was not his job to cover all the science concepts but just to do what came up well and that the selection was "almost a lucky bag" (written note 12/6/84). He went on to summarise how he saw his role in helping pupils make connections so their "patchwork quilt" could be constructed:

I'd like to lay a little more emphasis on the connection the children should make between the various experiences given. The quality of the connections will depend on the intellectual capability of the child but I think it is one of the prime obligations of the teacher to:

- i) Plan investigations and activities that are connected in some way and not a rag bag.
- ii) Draw the children's attention to the connections between their play and everyday experiences and their work in science. This can be done either as a class or in small groups.
- iii) Occasionally offer the benefit of his experience in terms of theories he knows about such as the way energy is changed from one form to another or stored or some of the aspects of friction that aren't obvious, eg that there is friction between the air and objects flying through it.
(Teacher's note 15/6/84)

The teacher's theories were analysed on the basis of his reports and related to his planning and his thinking-in-action during lessons, which sometimes stimulated their expression and review. In his theories about primary science, pupils, learning and teaching his beliefs and knowledge were closely related and more personal views and feelings were involved. Currently there

is a concern to remedy the neglect of teachers' knowledge, especially that concerning specific curriculum areas, in research on teachers' thinking (see eg Peterson, 1988; Roehler et al 1988). This necessary emphasis on cognition and subject knowledge could run the risk of isolating it rather than examining how it is held and used as part of personally integrated theories.

Any model of teachers' theories which is to have wider significance must not be static nor limited to teachers with very specialised expertise. In the particular case of primary science it is important that representations of how theories are structured and developed are not restricted to the minority of teachers with a substantial knowledge of the subject. The demands of primary science will require a significant restructuring of the theories of many teachers as they extend their knowledge-base and seek to integrate it with their beliefs and professional knowledge. In this study the teacher's views about learning were found to play a central role in his theories and it is likely that this would be true for most teachers working in the same tradition of primary education. Chapter 3 noted Harlen and Osborne's (1985) argument that a rationale for primary science should be based on a view of the intended learning and how this should occur, rather than on some general aims of primary science; it introduced their general model of learning (figure 3.1) within which any particular view of learning can be located and relationships among the elements can

be examined for consistency between theories, plans and evaluations, and classroom practice.

Evidence of how the teacher's theories of learning and teaching primary science were related to his planning and thinking-in-action has been provided in this study. For example their direct influence on his plans and his classroom decisions was seen at points in his references to the need for experience, exploration and play. Often the relationship was complex, involving other elements of his theories and the situation, and tensions were sometimes present as he combined these in his planning and management of lessons. The tensions sometimes stimulated re-examination of theories, as illustrated in his reflections on design and skills teaching. The teacher's views were closely connected to his use of knowledge, for instance in his comments on how he felt he should draw upon his own scientific understanding or how he selected topics and activities from the repertoire he had built. The concept of a repertoire proved important for modelling the way his curriculum knowledge was held and used and developed. The term was derived from the teacher's report of this, and related to its use in the literature particularly in the work of Schon (1983; 1987) and Shulman (Wilson, Shulman and Richert, 1986). Shulman has proposed a model for the transformation and use of knowledge in which experienced teachers draw upon a

representational repertoire, which consists of the metaphors, analogies, illustrations, activities, and examples that teachers use to transform the content for instruction (Wilson, Shulman and Richert, 1986, p119-120).

This was developed for studying secondary subject teachers but has some similarities to the analysis in this case. The concept of a repertoire proved especially useful for analysing how the teacher's planning drew upon his knowledge and how his thinking during planning and teaching could enrich and modify that knowledge and associated beliefs. Evidence was seen of ideas being explored in imagined and real action and compared to his existing knowledge.

For example the teacher drew upon his established repertoire of activities, such as testing toy cars or experimenting with bicycles. He made use of activities and techniques which he had encountered but not yet tried in practice with pupils, such as designing and making model vehicles. And he sought ideas for new activities from published curriculum materials. He did not simply take ideas from his repertoire or other sources; nor did he simply return or deposit them there. He adapted them to suit his aims and the situation and in the process changed the way his ideas were held or integrated new activities into his repertoire. For instance he became more aware of the demands of the toy car task he had set; discovered that activities with models could be used to emphasise either controlled testing or design and construction; and developed new activities based on published suggestions for investigations with mangonels. In these ways his repertoire was enriched, and to some degree restructured. This in turn increased its potential for future use.

13.4 Planning

The teacher in this case planned in a variety of ways. Some of his planning was written down but most was done mentally. He thought about his plans and evaluations before, between and after lessons; in odd moments on his way to and from school; sometimes more deliberately in the evenings at home; ideas crystallised late at night or early in the morning and when he was preparing resources or trying out activities for himself. There were several kinds of planning, referred to in the earlier chapters as layers.

One layer involved thoughts about long term aims and strategies, with reference to his views about learning and to his experience with different teaching approaches and classes. This was seen from the start of the year as he diagnosed the character of his new class, identified his intention to make the pupils more independent and better at carrying out their own inquiries, and set up the initial frame in which his later planning was located.

At the next layer his science teaching was planned around termly topics. These were chosen with reference to his experience of teaching similar topics with other classes, his concern to balance the science and to integrate the curriculum, and the particular opportunities of the situation which he personally wanted to use. The topics served as themes around which most of

the science teaching was organised. The topic in the third term, which was the focus of this study, was planned as a vehicle for pupils' investigations and problem-solving, with some incidental teaching of concepts.

The key units in the process of planning that topic were activities selected from the teacher's repertoire, extended by reference to other sources. A number of potential activities, such as experimenting with cars and bicycles, and making and testing models, were identified at an early stage but their selection and sequence was not fixed. The exploration of alternative ways of organising them was a major feature of this layer of planning. The teacher envisaged the term's topic as a flow of activity through a small number of activities which pupils would pursue at length, interspersed with more directed lessons, as represented in figure 8.2. His image of how each activity would operate was focussed more sharply as the time to introduce it approached. The study traced this process and analysed the teacher's decisions from his initial selection of downhill investigations with toy cars at the end of the spring term through to the end of the summer term when he modified his plan for using bicycle activities into a more open choice for pupils. The analysis of those decisions revealed the complexity of the planning process as he considered the situation and pupils' responses, referred to his theories, and moved among layers of planning.

The next layer of planning involved translating activities into a series of lessons, and forming images of each lesson. Those images were sharpened as the time came to translate them into reality. In planning lessons the teacher envisaged the setting of tasks, his roles and pupils' responses, and the flow of activity overtime. Some of this was summarised in short written lesson plans but those were only the tip of the iceberg of thinking which preceded a lesson.

Although the different layers of planning were distinguished in the analysis they were not necessarily thought about at different times or in a fixed sequence. The teacher's planning could encompass several layers, and also combine preactive and postactive thinking.

The teacher's postactive thoughts, arising from events in lessons or from his reviews of his planning, were closely linked to plans for later lessons. This was illustrated in his extended reflection at our interview on 2 May when he moved from evaluating the previous day's lesson to mulling over his plans for the rest of the term and firming up his immediate plan for the next stage. His postactive thinking often combined assessment of pupils' progress and of his own teaching with reflection on his theories and planning. Sometimes he looked even further ahead, as in our final interview after the end of term when he considered alternative ways of using the activities in new circumstances.

The teacher's planning, including preactive and postactive thinking, was analysed over the year of the study. Although he engaged in various kinds of planning which did not simply fit any one standardised model it was possible to detect an underlying structure to his thinking. A layered or nested picture of the planning process was confirmed and developed to incorporate the movement between layers, as depicted in figure 8.1. Images of the flow of activity over time were formed at each layer. Planning thoughts could move back and forth in time and be tested against real or imagined action. As the time for implementing a plan approached the image of the term, unit or lesson was focussed to form a basis for action. Means and ends and circumstances were considered interactively, rather than separated as in linear models of planning. Cyclical models, such as those discussed by Clark and Yinger (1987), are more appropriate to convey the process and the movement between plans, theories and thinking-in-action. The analysis suggested that teacher planning had much in common with Schon's (1983, 1987) concept of reflection-in-action, in which a practitioner experiments with various ways of approaching new situations. Where this is a thought experiment it is possible to control the action and constraints, vary and rerun different moves, and rehearse the alternative roles and procedures. This 'practice of practice' in what Schon (1983) has termed virtual worlds was represented in this study by the images which the teacher formed and reviewed. Activities in his repertoire were important units

in the formation of the images in his planning of the topic in this case.

Activities have been significant features in other studies of planning although their importance may vary among teachers and circumstances, and the term activity has a range of meanings. For example in reporting his study of a teacher's planning Yinger (1980) referred to activities as controlled behaviour settings. In studies of classroom organisation they may also be seen as basic units but denote relatively short blocks of time, typically 10 to 20 minutes, during which students are arranged in a particular way (Doyle, 1986). In the present study an activity was defined as a basic unit in planning which could refer to one or more pupil tasks having a common purpose, and these might extend over several lessons. In exploring the transferability of this analysis of planning terms will need to be carefully defined. Teachers' repertoires may also be found to be organised in units other than activities - for instance classroom procedures and roles.

The analysis of planning in Chapter 8 and the discussion here has tended to reinforce the emphasis on the preactive phase found in most of the literature. However Chapters 9 to 12 reported the teacher's postactive thinking which occurred immediately after classroom action, more reflectively outside lessons, and

summatively at interview. Some systematic assessment of pupil progress and evaluation of the topic and of his own teaching were seen, but there was not evidence of a planned evaluation or assessment strategy consistent with any linear model of planning. Many of the explicit reports may have been in response to my questions, for example at the final interview, but most of the evidence of postactive thinking came from spontaneous comments. There were many occasions when the teacher's thinking moved from evaluation to plans as he talked after lessons or in interviews, for example on 2 May. Within a dynamic model of planning postactive thought can be viewed as part of the review, extension and anticipated use of the teacher's repertoire. It focusses on past action in order to inform images of future action as new situations are considered. This may be immediate as the next step is planned, or refer to more distant layers of planning such as the next unit or term, or to potential uses in other situations such as the new school to which this teacher was moving. Postactive thinking can then be related to the concept of reflection-in-action, and to the layered representation of planning summarised in this case in figure 8.1. The content and process are similar to those of preactive thinking, for example in its movement in time and the interaction between ends and means, but some distinctions may be appropriate. Whereas preactive thoughts can be depicted as focussing down from images at more general levels onto the imminent action, postactive thinking may be viewed as beginning from a specific experience and moving outward. Its initial specificity may colour the sort

of thinking that occurs, for example as it is influenced by features which Nisbett and Ross (1980) have identified as influencing human judgements, such as the recency and vividness of evidence. Lowyck (1986) reported that teachers in his study of post-interactive thinking reflected upon events that were striking to them, and tended to generalise from very concrete instances. He also stressed that planning before lessons and thinking afterwards are closely connected.

The model of teacher planning derived in this case was seen to have much in common with an account of reflection-in-action developed from observing other professions (Schon, 1983) but teachers have limited time in which to plan for a variety of pupils over a wide curriculum. Their planning will often have to be abbreviated or routinised. Their opportunity for extended reflection-in-action may not match those in many of the cases observed by Schon. The opportunities are even more limited during lessons.

13.5 Thinking-in-Action

The teacher's thinking during lessons was referred to as thinking-in-action to convey its orientation toward action in a specific classroom situation, but also to avoid the limitations implied by adoption of the terms interactive thought or decision-making. It was found to include not only thoughts about interactions with pupils or decisions but also, for example,

evaluations of progress, review of plans, and reference to his theories.

The images he formed during planning were seen to frame his thinking in the lessons but discrepancies between the image and reality prompted other thoughts. Some were concerned with his immediate management and teaching, leading to fine tuning of the plan and the making or deliberate deferral of decisions. The cue for these was often the behaviour of pupils, for example as they explored materials or encountered difficulties he had not anticipated. For instance in Chapter 10 he was seen on 14 May deciding to extend the time for such exploration and on 7 June making a larger decision to shift to a new activity because of pupils' failures and frustration. The analysis showed how such decisions were not however simply a response to cues from pupils but also involved his theories and his long term plans. For example his extension of time on 14 May reflected his belief in the importance of "a play stage in learning". The long term aims and strategies he had identified continued to influence his decision, and interaction, in lessons over the term as he sought to help pupils develop their own investigations.

The analysis of those interactions identified dilemmas in his thinking concerning the use of time, his interventions, skills teaching, and the relative claims of process and product. These were connected and associated with feelings of tension, as illustrated for example in his comment at half term.

I've got a problem ... because I'm trying to keep them doing it themselves I'm ... I could make it much more efficient ((he illustrates how he could direct pupils to make a vehicle)). Now that would be efficient and they'd get through it quickly .. they'd do it much better than they're doing it at the moment .. that wouldn't be getting what I want them to do .. to get out of it that is .. independence and being able to organise themselves .. there is a great tension there .. and the product would be better.
(Interview 27/5/84)

His management of those dilemmas involved thinking and action in lessons and more extended reflection outside lessons which led to some review and restructuring of his theories. For instance he developed a more differentiated view of his interventions and skills teaching which he summarised in the course of that interview as "where they've got ideas .. don't do much except help them in their own clarifying . where there are materials or skills be quite prescriptive". He explored that principle in practice in the subsequent lessons. Analysis of his dilemmas provided insights into such relationships between the teacher's thinking and action.

While it may at times have incorporated or stimulated reflection about theories and plans much of the teacher's thinking during lessons was of course concerned with the immediate demands of management and teaching. In active science lessons with a class of 28 nine to ten year olds the teacher had to attend to multiple demands, make hurried decisions and sometimes think under pressure when, as he phrased it, "the world is too much with you". In the achievement of such lessons the thinking that accompanies actions may not be easily recognised nor made

explicit.

Although the thinking in busy lessons may be largely tacit, and the opportunity for extended reflection limited, there was some evidence of reflective practice similar to that during planning. For example some of the teacher's thoughts were concerned with using the lesson experimentally. A lesson can be an experiment in the general sense of testing the plan in action, and specifically in three senses distinguished by Schon (1987). It can be simply exploratory, intended to see what happens if some action is undertaken; it may involve testing strategies to see if they produce the anticipated consequences, which Schon terms *move-testing*; and it may be more systematically designed to test hypotheses. All three functions can be fulfilled by the same actions in Schon's view of experimenting in practice. In this case examples were seen in the teacher's use of time, or his handling of his own interventions, where he set out to see what happened, anticipated and monitored the effects of deliberate moves, and sought to test his hypotheses about fostering independent inquiry.

A note of caution or realism may be needed here. In arguing for a picture of teaching as reflective practice it is not being claimed that teachers spend most of their time during lessons engaged in reflection, or significantly extending their knowledge. Much classroom teaching is necessarily routinised, repetitive, and may be concerned with coping rather than learning

more about teaching. Decisions may be based on contingent circumstances and immediate cues from pupil responses. A focus on one aspect of practice may mean that others are given less thought. The study reported how the teacher in this case commented that he had perhaps taken his class discussions for granted because he was concentrating on his interactions with pupils and their activities.

However in the skilled performance of an experienced teacher thought and action were seen to be related in a number of ways.

1. In the use of routines where thinking or knowing is implicit in the action (for instance when the teacher handled multiple demands from pupils or managed the transitions in lessons). These are viewed in subjectivist models as representing teachers' knowledge rather than being automatic and unthinking (Halkes, 1986; Olson, 1984). In Schon's account they reveal knowing-in-action (1987). In the words of the teacher in this case they are "just intelligent teaching".
2. In the realisation of plans and the evaluation of action as a lesson unfolds.
3. In references to other levels of planning, theories, and situational features to inform decisions and interactions.
4. In reflection on events, or problems, which may subsequently

modify images held in planning or influence theories. This last possibility may arise from the experimenting in practice discussed above. For example the teacher's use of new techniques or approaches in teaching design stimulated him to review some of his principles of teaching. The experience of action and the feelings of tension associated with dilemmas were seen to be important for prompting the examination of his theories. Some of the complexity and personal nature of thinking-in-action, and its links with other aspects of thought, were revealed in the analysis of dilemmas.

Thinking-in-action then is varied, personal, and related to plans, theories and the situation, as well as to the immediate action in a number of ways. In modelling thinking in lessons this complexity needs to be reflected rather than reduced to fit models of decision-making or information processing. Clark and Peterson (1983) argued that the imposition of models of interactive thinking was premature. Lampert's work with teachers (1981,1985,1986) demonstrates how detailed analysis of dilemmas from the perspective of individual teachers can yield a picture of the relation between action and reflection in classroom thinking which is broader than decision-making. It recognises the personal quality of thought, the uniqueness and value conflict inherent in teaching situations, and the individual differences among teachers. It presents a model of teaching as exploratory, continuously redefining goals and reassessing means as it moves towards those goals in tiny increments (Lampert,

1986). This view is consistent with the analysis of the present case and similar to Schon's (1987) picture of experimentation in practice which was noted above. However it should not be forgotten that much of a teacher's thinking-in-action is likely to be concerned with the routine management of lessons or implementation of plans rather than with experimentation or reflection.

13.6 Summary of Relationships and Concepts in an Integrated Model of Teachers' Thinking

Figure 13.2 depicts the relationships among the major elements in a teacher's thinking and practice which were identified in this study. It is based on the working model developed in Chapter 4, recalled in figure 13.1. The minor modifications made in the light of the final analysis are concerned with the representation of some of the relationships among aspects of thinking. It also indicates that those aspects may be variously influenced by situational features ranging from the broad socio-historical context to the immediate school setting.

The three aspects of thinking analysed above are all related to classroom action, and to time, but in different ways.

Thinking-in-action is closely connected with immediate actions in lessons. Planning can move backwards and forwards in time as actions are envisaged and evaluated. Theories develop over a longer time scale as reflection upon experience extends and

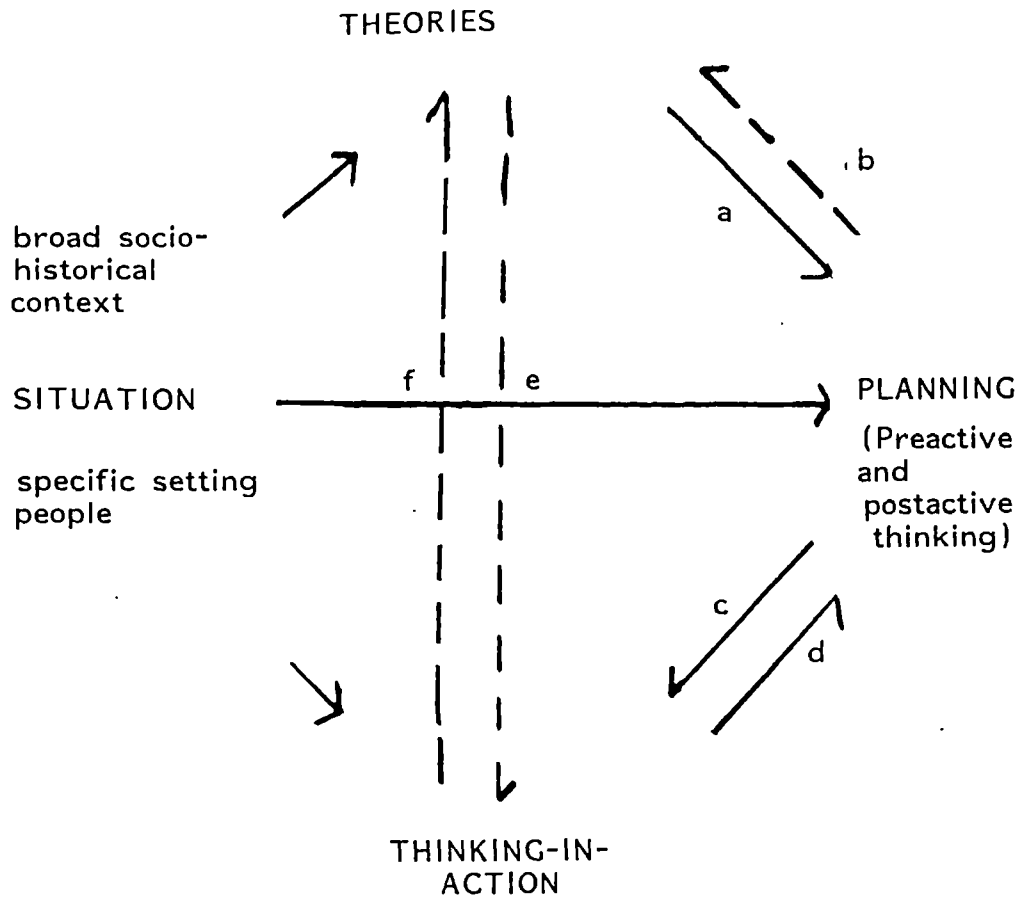

Figure 13.2 Major elements and relationships identified in this study of thinking

restructures knowledge and beliefs; that experience arises and is applied in the real action of lessons and the imagined action of plans.

The integrated picture of thinking in relation to action in a particular situation represented in figure 13.2 shows links between all three aspects. A linear model that simply showed theories guiding plans, which in turn directed actions, would ignore the link between the teacher's theories and thinking-in-action. That could be incorporated in a simple circular representation which could be modified to show movement back and forth among aspects. The starting point for developing the working model in this case was in fact such a representation (figure 4.1). However the analysis of the case revealed a variety of relationships which are not represented in such a neatly symmetrical figure.

The working model summarised in figure 13.1 represented the different relationships tentatively identified from early analysis of this case. Arrows showed theories as influencing both plans and the thinking-in-action during lessons. Double arrows anticipated a reciprocal link between planning and thinking-in-action. A dotted arrow from thinking-in-action to theories indicated a potential relationship to investigate. The detailed analysis presented in Chapters 7 to 12 suggested minor modifications to those, leading to the final representation in figure 13.2. The more obvious links are summarised by continuous

arrows while dotted arrows show relationships which are less evident and which may be less frequent in practice, but particularly important for professional development. In this case they were traced by analysis of an experienced teacher's thinking as he promoted inquiry learning, tried out new ideas, and deliberately set out to examine his practice in the presence of a researcher. Those circumstances and the focus of the research may have made links with theories more frequent and visible.

The beliefs and knowledge subsumed under the heading of theories were shown to influence planning. The teacher's beliefs about learning and primary science guided his choice of activities and teaching approaches as he drew upon his repertoire of knowledge. This happened from the first tentative plans for the topic to the final lesson plan, and is represented by arrow a. The reciprocal relationship in which planning stimulated examination of his beliefs and extension of his repertoire was identified during the study and is shown by the dotted arrow b. The movement to and fro between planning and thinking-in-action represented by double arrows c and d was confirmed and examined in the analysis. It involved the framing of the teacher's thoughts in lessons by the images formed at several layers of planning, and the evaluations arising from thinking during lessons.

A firm link from theories to thinking-in-action was proposed in figure 13.1, based on the early analysis which drew heavily on

the teacher's reports on his practice. Some of the literature reviewed had suggested however that teachers' theories were not applied in lessons, largely because of the more immediate demands of classroom teaching. The analysis of the term's lessons, while recognising that such demands and the framework of planning shaped much of his thinking during lessons, identified instances where the teacher's theories directly influenced his actions and thoughts in the classroom. For example in prioritising pupils' practical activity and application of their knowledge he was applying his theories of learning in his classroom practice.

The dotted arrow e from theories to thinking-in-action affirms that a teacher's theoretical orientations can directly affect practice in lessons although this influence may not be obvious and may be constrained. The reciprocal link from thinking-in-action to theories proposed in figure 13.1 was traced in the analysis of dilemmas. It is shown as broken arrow f in figure 13.2, since it too may not be obvious or frequent in everyday classroom practice. However dilemmas were seen in this case as significant sources for the development of the teachers' theories. For instance his extended review of his beliefs about teaching skills and the role of the teacher was stimulated and sustained by events and thoughts in lessons. The two dotted arrows between theories and thinking-in-action also represent the movement between the teacher's repertoire of knowledge and his classroom practice as he drew upon his experience, for instance of managing science lessons, and extended it by trying new teaching approaches.

The overall picture of this experienced teacher's thinking was found to have much in common with a general model of the reflective practice of professionals. The concept of reflection-in-action in that model was found to be relevant, especially to planning, although teaching may often be less reflective and more hurried than the reflection-in-action of designers and other professionals observed by Schon (1983, 1987). Even with the characteristic uncertainty and conflict of classroom teaching, and the multiple demands of active science lessons, practice was seen to be thoughtful and exploratory and personal. This can be captured in a model of thinking and practice which is subjective and dynamic. It needs to be subjective to convey how thinking and action are integrated in particular situations by individual teachers. It needs to be dynamic to represent the movement between aspects of thought, action and context; to reflect the interaction and review of ends and means; and to convey the process by which teachers' knowledge grows. Rather than providing a static picture such a model can shift attention to the use and development of knowledge through practice as advocated by Erickson (1987).

Three concepts were derived from the data, extending their use in the literature: repertoire, image and dilemma. The concept of a repertoire proved powerful for analysing the teacher's knowledge and the relationship between that and the process of planning. The term was introduced by the teacher to refer to the ideas for topics and activities that he had built up through experience of

using them. It conveyed the dynamic nature of that knowledge base as further experience extended it. In this case activities were key units in the teacher's use of his repertoire during planning. However it was recognised that other units might be more significant in other cases, and that the term activity is used in a variety of ways in the literature.

Drawing upon his repertoire of knowledge and related beliefs the teacher formed images at each layer of planning. These images framed the thinking during lessons. This conceptualisation conveyed the nature of the planning process and its relationships with theories and thinking-in-action. The terminology of envisaging alternative images and focussing one as the time to implement a plan approached was particularly appropriate. However the term image has several connotations in research on teaching and it will need to be carefully defined if used. Calderhead (1988) discussed the different levels of abstraction to which the term may be applied, ranging from images of a particular lesson or activity to more abstract images of the classroom atmosphere and relationships which a teacher values, concluding that

How these images at different levels of abstraction interact with one another requires further exploration, but the term image seems a potentially useful one to describe the repertoire of influential models, cases, typifications and incidents that act in the mind of the teacher as exemplars, metaphors and guides for action.
(Calderhead, 1988, p55)

Dilemmas had been identified and analysed in several of the

studies of teacher thinking reviewed in Chapter 3. Their analysis in this study gave insights into the nature of the teacher's thinking-in-action and its relationship with his theories. The term 'dilemma' was in fact used by the teacher in this case. It conveys the combination of cognition with feeling, of the need for action with a cause for reflection, and of a particular problem with wider significance. It is particularly appropriate for analysing the thinking of individual teachers in unique situations of practice in order to support their individual development and to contribute to the knowledge base of their profession.

The relevance of the concepts and model developed from this case can be explored in other studies with teachers to see how well they match the analysis of their thinking, and how they can inform their practice and support their professional development.

CHAPTER 14 IMPLICATIONS OF THE STUDY: TEACHERS' THINKING,
PRIMARY SCIENCE, PROFESSIONAL DEVELOPMENT AND
THE CHALLENGE OF CURRICULUM CHANGE

This chapter discusses the implications of the study for research into teachers' thinking for primary science and for teacher's professional development and in-service education. These three areas are examined in turn and common ground is identified concerning the thinking and practice of teachers as they face new challenges. Since the study was completed the introduction of a National Curriculum in England and Wales has created a new set of challenges for teachers which are especially acute in the field of primary science.

14.1 Research in Teachers' Thinking: Methodological Issues Concerning the Style and Use of Research with Teachers

In Chapter 2 it was argued that case study is especially appropriate for capturing and conveying the complexity of thought in relation to specific practice. This has been demonstrated in the present study, which has analysed thinking and practice in one case of primary science teaching. It has characterised teaching as personal, reflective practice which involves movement between theories, layers of planning, and thinking during lessons. The links between those three aspects, and their relationships with the classroom action, have been revealed within an integrated account. However their integration did not preclude their analysis. Case studies can include detailed accounts of planning as it occurs in specific subjects, examination of the content and structure and growth of teachers'

theories, and analysis of their thinking-in-action in classrooms.

A number of questions about the style and use of such research need to be addressed.

The present study grew out of work with a group of teachers who were committed to sharing their thinking. Materials from that work, including data from this case, were used in a variety of ways more widely on in-service activities - for example transcripts, pupils' work and teachers' plans were studied with groups of teachers. The teacher in the study had emphasised at the first interview that he looked forward to participating and to "seeing what's going to happen ... well what comes out of your teaching." At the final interview he noted how he had welcomed the concentrated attention on an area of his practice, and particularly valued the opportunities provided by having an interested observer and listener. He also commented on the potential of sharing his experience with others.

I think this would be very useful because a lot of people have those aspirations that I've just said about getting their children to be more independent but they in fact don't know where they're going to start . and ... whilst I . I've been doing it for a few years . trying those ideas out and finding out just where . I fall down (Interview 20/3/84)

Teachers then may gain individually from their involvement in research of this sort and can share their thinking and practice with others in a number of ways. How can this be more systematically extended, and is it rigorous enough to constitute research? What roles do researchers have and how are such studies to be cumulated and disseminated? These sorts of

questions have been addressed in recent years in the growing literature on action-research. Ebbutt's (1985) discussion, based on the Teacher-Pupil Interaction and the Quality of Learning Project, is particularly relevant to the present study. In exploring where action-research might fit in the range of normal "insider-research-related activity" Ebbutt (1985, table 1) provided a classification which ranged from isolated reflection on practice to systematic action and reflection with the help of a consultant and as a member of a group. Action-research and case study by practitioners extend the sort of reflective practice analysed in this case. However the different roles and interests of researchers and practitioners need to be carefully articulated; Ebbutt cited Schon to emphasise that the differences are concerned with the relationship between understanding things and changing them.

the practitioner has an interest in transforming the situation from what it is to something he likes better. He also has an interest in understanding the situation but it is in the service of his interest in change
(Schon, 1983, p14)

There are a few accounts of productive collaboration in the pursuit of understanding and change in primary science practice, for example in the Ford Teaching Project (nd) and in Ovens and Ryan (1984). Ovens worked with a teacher who sought to understand and alter her pupils' apparent lack of curiosity. The paper reports the classroom activities and gains for the pupils and the teacher over a year, and analyses changes in her interactions with children, her planning, and her beliefs about

teaching and learning. That paper was presented to the Classroom Action Research Network (CARN), which was established to foster sharing among teachers and those working with them. There are many constraints on the effective dissemination and use of such work stemming from existing traditions in teaching and research. These include the isolation of teachers, their view of research, the standards and communication channels of the research community, and the pressures on teachers.

Although the teacher in this case normally worked alone with his class he was involved with other teachers as a science and maths consultant. The growth of such specialist responsibilities is reducing the isolation of class teachers in primary schools. Campbell (1985) has discussed the shifts in attitudes and relationships occurring around the time of the present study "that point, albeit uncertainly, in the direction of collegiality and away from individualistic roles in private and autonomous classrooms" (p159). The growth of collective use by staff of specialist expertise for policy making and practice by a school is but the first step toward sharing critical reflection on their classroom practice. The trend toward collegiality and school-based curriculum development provides a forum for studying and sharing thinking and practice beyond individual classrooms. Teacher-researchers, and those concerned to support and share their learning, can work with whole schools and seek ways in which their insights can be disseminated and validated more widely. There are some accounts of such partnerships (eg Galton

and Willcocks, 1983, ch 11).

However many teachers are ambivalent about research, which they may see either as a status activity or as irrelevant to the realities of their classrooms. They may not believe that their own practice is of wider significance, nor that studying it and sharing it are part of their wider professional role.

Researchers also face new challenges, for example in working from the particular, unpredictable, situations of classrooms or seeking to stay close to the meanings and language of teachers without further fragmentation of the field and confusion over terms. This study sought to locate the case in relation to the literature and to identify terms and models which were used. Some difficulties over the range of meanings attached to terms such as activity and image were discussed. The review of the literature identified a concern for consolidation rather than proliferation of terminology and conceptual frameworks (eg Clark, 1986; Calderhead, 1987b). Lampert (1984) noted there were difficulties for teacher-researchers because teaching in practice and thinking about teaching may draw on different models, but she has shown the potential of studies which start from the particular problems of individual teachers. Lampert was herself working as a classroom teacher and studying her own practice as part of the research programme.

To qualify as research such work needs to produce a publicly accessible report. Conventional ways of disseminating research

findings, and the standards for judging them, do not encourage practitioner-researchers nor influence the practice of many teachers. Research papers, journals, and conferences may be used by some teachers and contributed to by an even smaller number. Case studies such as the present thesis are time consuming to produce and to consult. The format for presenting research and access to such information can be modified to ease communication among teachers, and developments in information technology may help to some extent as argued by Bell (1982), but new ways of sharing the knowledge of practice and thinking about it are needed. Face-to-face groups and networks of practitioners have been developed in recent years from initiatives by groups of teacher-researchers (eg CARN) or from courses and projects which have sought to cast teachers in such roles (eg the Initiatives in Primary Science Education project for advisory teachers). It remains to be seen how lasting these will be - or should be. Subject associations serve as a regional and national network and meeting place for professional exchange, and the Association of Science Education has now become such a mechanism for communication by large numbers of primary teachers. The production of materials for use by teachers can incorporate research-based approaches by participants, disseminating the process as well as findings, as happened with the Progress in Learning Science Project (Match and Mismatch, 1977). The review of literature noted more recent science projects involving primary teachers in action and research (LISP, STAR, SPACE, CLIS Progression Project). The field of teachers' thinking needs to

draw upon such subject-specific developments.

The pressures on teachers are increased as they accept responsibility for curriculum development and collaboration with colleagues. In the present case the teacher's responsibility for science and mathematics included policy development, resourcing, staff support, and liaison within the school; he was also running a science group for the LEA, and taking part in the work of the group of teachers described at the start of this study. In his next post the development of work with microcomputers was added to his administrative, pastoral and diplomatic responsibilities as a deputy head. Campbell (1985) has discussed the lack of time and support available to teachers engaged in school-based curriculum development. Individual teachers may find it difficult to extend their role further to include research-related activities. There is also a danger that those who are involved, or who are the subject of studies such as the present one, are not representative of the wider profession. They may be those who are especially interested in further study or promotion, or those who most closely fit the style of research or the models of teaching used. Clark (1986) has perhaps overstated this when he says that research on teachers' thinking has

elevated and lionised those few teachers who are most like ourselves (reflective, analytic, verbally articulate, sophisticated in their knowledge, liberal and worldly in their values). These are the teachers whose planning, thinking and decision-making we study, and unreflectively portray as ideals for all other teachers, experienced and novice alike. (Clark, 1986,p16)

If the study of teachers' thinking is to involve and serve the majority of teachers then it is even more important that their working conditions make this possible, providing the time and support services that do this and at the same time signalling its importance. This is not only the responsibility of those who define teachers' conditions of service and the way those operate, but also of researchers and other outsiders who wish to collaborate with them to extend their mutual understanding of thinking and practice. At a general level it includes attention to the sort of contracts and frameworks that are negotiated. It requires consideration of the sort of feedback which teachers should expect and find useful, and of what are reasonable demands to make - for example how much written documentation a teacher can sustain, as was discussed in this case. Last, but by no means least, it may mean the provision of small amounts of funding, time or facilities such as reprographics and typing.

14.2 Research in Teachers' Thinking: Substantive Issues Concerning the Context, Content and Structure of Teachers' Thinking

14.2.1 Theories

Theories held by a teacher can be analysed in the course of naturalistic studies, such as the present one, or through more structured approaches. Teachers may become more aware of their

underlying theories through involvement in such studies and it is argued below that this is important for their professional development. Although studies may focus on a particular feature of teachers' theories, for example their subject knowledge, it is important to recognise that in practice this is not isolated from other features in a teacher's thinking. In this case the connection of feelings, beliefs and a range of professional knowledge was illustrated, and the relationships of the teacher's theories to his planning and thinking-in-action were analysed.

A teacher's thinking also has to be studied in relation to the particular teaching situation, the individual teacher's career and the wider educational context, any of which may change. It would be possible to relate changes at the level of society and institutions to changing classroom practice through extended case studies of primary science teaching. The interactions between individuals and institutions could be traced, for example with reference to the centralisation of control and the growth of subject studies in primary education as the National Curriculum is introduced. Teacher thinking is not merely the result of personal history and psychology nor simply shaped by socio-political circumstances. Rather it reflects the complex interplay between such features of the situation. Case studies can reveal that complexity and in the process inform our understanding of more general issues such as the position of professionals and their knowledge in a changing society.

Some researchers are accumulating biographies of teachers to examine their thinking (eg Butt, 1984). Longitudinal studies have particular potential for tracing the development and use of theories by individual teachers. Multiple case studies could be conducted to examine how different teachers working in similar curriculum areas draw upon their knowledge and beliefs. In combination they could be used to relate that microanalysis to the macroanalysis of changing ideologies and political climate. There is at present a particular opportunity for research into the theories of teachers of primary science in relation to educational change in the UK.

The concept of a repertoire was developed in this study to examine how a teacher's professional knowledge was held and used and extended. The content, structure and use of the teacher's repertoire were analysed and insights were gained into its history and its extension. The construction and reconstruction of that repertoire derived from reflection upon experience, growing from thinking-in-action during lessons and from planning. The idea of a repertoire can be applied in a number of ways in further studies. First researchers could compare the content of teacher's repertoires, for example in relation to the demands of teaching a subject such as science in the National Curriculum. In the review of literature it was noted that prescriptions of the knowledge needed for teaching primary science have been based on general assumptions rather than empirical research. Second the concept of a repertoire can be applied in representing the

structure of that knowledge. Relationships among different kinds of knowledge can be analysed, for example to examine how teachers combine their general understanding of teaching strategies with specific subject knowledge. Third the idea of a repertoire has particular potential for studying how teachers construct and develop their knowledge, for example as novices build a repertoire or as experienced teachers face new challenges. Finally it can be used to conceptualise how teachers use their knowledge and draw upon their experience in their planning and classroom teaching. Research that combines all four aspects in a specific subject context can provide a basis for curriculum innovation and staff development. Smith and Neale (1987) argue that earlier curriculum innovations failed to recognise the complexity of knowledge required for good science teaching. They analysed the content and structure of knowledge needed for successful conceptual change teaching as a basis for their own longitudinal programme of work on the construction and use of knowledge by primary teachers.

14.2.2 Planning

This study elaborated a picture of planning as a nested or layered process, with movement to and fro between layers. It was consistent with a view of planning as more dynamic or experimental than the linear models often prescribed to teachers in training. Schon's notion of reflection-in-action was seen as particularly appropriate to describe it. The use of the

teacher's repertoire of activities in his planning of the topic studies was analysed. Links with the thinking and actions during lessons were traced through the formation of images. Postactive thinking was examined, having been identified in the literature review as an underresearched area. The complex process of planning was traced from the start of the year in this case.

Clark and Yinger (1987) argue that

educators could benefit from more studies which describe the full range of the kinds of planning that teachers do during the school year and the interrelationships between these (p89).

Teacher educators and curriculum developers need to know how the teachers with whom they work think about their planning. For instance curriculum proposals based on statements of objectives may be implemented by teachers who begin their planning by identifying potential activities. Any mismatch between models of planning assumed by curriculum developers and those used by teachers has consequences for curriculum implementation. The different planning orientation of individuals can be related to their values and beliefs through case studies (Aikenhead, 1984; Smith and Anderson, 1983). Teachers may also be found to use different approaches in planning for different areas of the curriculum.

Several features of planning are in particular need of investigation and support in primary schools:

1. The collective planning by groups of primary teachers and

whole schools is an important area for investigation. Some primary schools have experience of this process. All are now faced with the challenge of doing this to meet legal requirements of delivering a common curriculum in ways that are appropriate to their priorities and beliefs.

2. The role of the teacher with expertise in a subject who helps colleagues plan in unfamiliar territory is ripe for study, and primary science offers a particularly rich field for such research at present.

3. The planning that teachers do as they seek to implement the National Curriculum within the framework of their different aims and planning styles will raise a host of questions. In this case the teacher was able to draw upon his own extensive repertoire in the subject area and plan with little reference to written policies or schemes. In future teachers, many of whom will have limited experience of science teaching, will be required to plan within the framework of national programmes of study and attainment targets. This might shift the emphasis of their planning toward the interpretation of guidelines and published materials. In the past this seemed more appropriate as a description of secondary school practice or the American scene than of British primary teaching (cf for example Clark, 1983). For some primary teachers it may provide a structure which was absent from their planning, for others it may narrow their focus to the achievement of assessed outcomes.

4. The links between plans and their realisation in lessons need detailed analysis. In this case planning involved experimentation with alternative strategies, the simultaneous review of ends and means, and the formation of images of the flow of activity. This implies a quite different relationship of plan to classroom action than that which has underpinned much teacher education. The metaphor of images could be applied in a variety of ways to assist teachers plan, from simple mental rehearsal to the use of techniques such as interactive video. Students and experienced teachers face problems, or set themselves new challenges in the process of planning, and we need a model of this process which informs and extends that. Alexander (1984) has pointed out how the models used in teacher education have failed to provide a basis for enhancing the processes of planning and evaluation.

5. The thinking that occurs after lessons needs more attention by researchers and teachers. It is often an afterthought in more than one sense. We need more research into postactive thinking that examines its relationship to the rest of the thinking done by teachers.

14.2.3 Thinking-in-action

Thinking-in-action was the term adopted to represent the teacher's thought during lessons. It was closely related to

classroom actions in a number of ways which included not only fine tuning within the framework of the image formed in planning, responses to pupils and the use of routines, but also the application of theories and reflection upon those. The stimulus of action was seen to be important for the review and restructuring of theories. These findings need to be set against studies which suggest that the pressures of classroom teaching may prevent even experienced and knowledgeable teachers from implementing or reflecting upon their theories of learning and teaching. The literature review noted evidence of the constraints of classroom conditions on the influence of teachers' theories of reading (Duffy, 1981) and the particular difficulties of achieving active science lessons and conceptual learning (eg in Barnes, 1983; Smith and Sendelbach, 1982). A recent study of mathematics teaching in infant schools identified the interacting forces of curriculum, management, instruction, and pupils' mediation of tasks which constrained teachers (Desforges and Cockburn, 1987). The teachers were skilled, industrious and held elaborate views of learning and teaching which included a commitment to higher order skills and problem solving in mathematics. Desforges and Cockburn relate their findings to the information-processing difficulties faced by teachers and particularly to Doyle's (1986) analysis of the conflicts between classroom management and instruction. Their study is particularly relevant here for three reasons: first they began with a concern to understand teachers' actions and thinking as they taught; second they were concerned with

the problem of establishing and sustaining a curriculum demanding the development of higher order thinking, including the skills associated with problem identification, problem solving and the acquisition of the strategies needed to apply basic concepts ...
(Desforges and Cockburn, 1987, p21-2)

and third they concluded that to achieve this researchers will need to collaborate with teachers and administrators to change the material and intellectual conditions of primary teaching. The present study suggests two routes for such collaboration which do not have major financial or structural implications. They begin from successes and problems of practice respectively.

The first would be to identify those conditions which favoured the development of problem solving and conceptual learning in science, mathematics and other curriculum areas as part of normal primary classroom teaching. Practitioner case studies would be particularly appropriate for this. The second route would start from dilemmas identified by teachers. Teachers who seek to introduce more investigative approaches and problem solving in their classrooms often experience the dilemmas over the pressure for products, the use of time, their own roles, and skill teaching, that were analysed in this study (Table 14.1). Their examination with teachers can begin with questions of classroom management and go beyond those to review the theories which underpin actions. The present study has demonstrated that dilemmas arising from the conflicting goals and demands of classroom teaching are a productive focus for analysing and extending a teacher's thinking.

TABLE 14.1 DILEMMAS OF THINKING AND PRACTICE
IDENTIFIED IN THIS STUDY

Dilemma 1 - Time

Pupils need time to pursue their own investigations

but

time is limited in school, lots of other things have to be done,
and teachers feel that tasks should be completed.

Dilemma 2 - Intervention

Children need to try out their own ideas, make mistakes, use
their initiative

but

teachers can see missed opportunities, they need to help
prevent failures and frustrations - they are there to teach.

Dilemma 3 - Process or Product

The particular process pupils go through and the experience
matters more than the particular products such as written
reports and models

but

stressing process can mean lots of time is spent on activity with
little visible evidence of learning and any final products may be
disappointing.

Dilemma 4 - Skills

Skills, techniques and more general approaches like
scientific investigation and the design process are taught most
effectively when pupils see a need

but

it is insufficient, unsystematic and frustrating to leave the
teaching of skills and general processes to chance, and not
to distinguish the different elements.

14.3 Primary Science: Promoting Investigations and Problem Solving

This section considers the implications of the case study for the promotion of investigations and problem-solving by pupils; in the next section their learning of scientific ideas and the teaching of knowledge and understanding in primary science are discussed in the light of this study.

In this case the teacher was able to promote a more exploratory approach by his pupils and extend their skills in the planning and implementation of investigations. However even this confident and experienced teacher of science faced challenges. The constraints of time, the need to cover the rest of the curriculum, accountability and the pressure for products were the source of some problems. Those factors were present but less pressing at the time of the study than at other times in the year or other stages in his career. Management and control of the class were not identified as difficulties, and resource limitations only surfaced occasionally. There was no syllabus or scheme specifying content which had to be covered. Most of the factors generally cited as obstacles to teaching science as inquiry, and developing pupils' abilities to carry out investigations or solve problems were reduced. Despite this a number of constraints were identified in the study, often by the teacher as he reflected upon his plans or the action. They

included the demands of the tasks, pupils' mediation of these, and uncertainty over the nature and learning of investigations and problem solving. These will be discussed in turn.

14.3.1 Selecting and setting tasks for pupils

The tasks set in this case were all intended to help pupils become better at planning and carrying out their own investigations. In each of the activities that were the units of the topic he tended to begin with a more limited task, then increase the demands in terms of skills and responsibility, and combine making and testing of models with investigation of variables. However there were often more variables involved than he had at first realised, for instance as he discovered when he tried the downhill tests with loaded vehicles at home. There were sometimes craft skills which needed teaching to free pupils to implement their ideas. And there was often a tension between the demands of construction and investigation, illustrated for example in the making of vehicles which he had intended them to test, as reported in Chapter 9.

Teachers need to analyse activities in detail, not so they can then teach their pupils isolated skills, but to inform their own actions in selecting and setting suitable tasks and intervening appropriately. Some of the analysis can be done in planning, and in trying out activities before, but the experience of teaching them in a classroom may be necessary before they are really part

of a teacher's repertoire. In this case the teacher might have anticipated some of the demands of the tasks more fully had he been more familiar with the craft techniques, for example, but many of the insights were gained only because the activities were explored with his class.

If activities have been analysed and tried in practice it will be easier to sequence them and adapt them to match each pupil. However difficulties still remain as teachers face the dilemmas summarised in table 14.1. When the concern is to foster independent inquiry yet also to teach component skills needed to successfully plan and implement investigations those dilemmas are particularly acute, as evidenced in this study. The teacher may see a logical sequence of teaching those skills but believe that each learner needs to chart their own route, ideally working on problems of her/his own choosing. This requires reflection-in-action of a high order and may only be possible when an extensive repertoire of activities and teaching approaches has been built through use of less open-ended strategies. Those who seek to help teachers introduce investigation and problem-solving need to recognise this; to ask them to run before they can walk may prove counterproductive.

14.3.2 Pupils' mediation of tasks

Even when the tasks are closely defined by their teacher pupils interpret and adopt them. Pupils' mediation of tasks was most

obvious in this study when they were imposing their own priorities. For instance the children's occupation with decorating vehicles reduced their efficiency as moving models and obscured the teacher's stated purpose of testing them. More pervasively, if less dramatically, it was seen in the way many pupils set about their investigations after the teacher had explicitly set them to pose their own questions, or identify and control variables, or plan and design. Often those became brief preliminaries to the manipulation of materials or the collection of measurements, even though the teacher may have emphasised their importance in an opening class session, or discussed with individuals their approach to the investigation. Occasionally his practice contradicted such statements of intent, chiefly when he asked them to adopt a design process to which he was not committed as illustrated in Chapter 10. However on the whole his aims expressed in planning, the objectives he explained to the class, and the emphasis in his interactions were consistent. There was plentiful evidence of pupils recognising and responding to his underlying purposes for the tasks from their behaviour and their interview statements. Why was this not always the case? Two possible reasons were hinted at by the teacher and are examined below. One was concerned with children's development and the other with their experience and expectations of schooling.

The teacher was initiating pupils into more deliberate investigation in his practice, and earlier in the year of the

study they had learnt more systematic approaches and specific skills which they applied during the third term, for example in checking and repeating measurements. However he also held the view that children do not naturally tackle problems in the way he was encouraging. He expressed this most explicitly in his reflections upon the design process, which were reported in Chapter 10. The approach of primary pupils to scientific activities will often be exploratory rather than a systematic investigation, and their purpose will be to see what happens through action or possibly to see if they can produce certain effects. Variables may be recognised, and a zealous concern for fair testing evident in the work of young pupils, but the development of a planned investigation or design is a long term goal. The proposal for this component of the National Curriculum (1988b) indicates the direction of this development toward more independent and systematic investigation but is properly hesitant about offering too prescriptive a view of progress and recognises that a pupil's performance is influenced by the way tasks are presented and by the subject matter and scientific ideas involved. Many primary teachers emphasise the need for first hand experience and exploratory play as a basis for developing more scientific investigations, and the importance of setting those investigations in a broader curriculum context.

The potential of tasks to promote such development may be limited by pupils' tendency to seek success in terms of lower level learning, completed tasks, correct answers and approval from

teachers for conforming. This has been identified as a contributory factor in preventing more investigative problem solving in mathematics lessons in Desforges and Cockburn's study (1987). In this case it was one which the teacher identified particularly in two pupils chosen for observation. They were seen in Chapter 9 interpreting the real purpose of the downhill investigations as the collection of a set of 'good results'. He attributed some of the tendency to dependency and conformity, which he diagnosed in the class generally, to their experience in the previous year. He sought to alter it through the overall climate he established from the beginning of the year. The study examined his interactions with pupils as he tried to avoid the trap of reducing the challenge to pupils without discouraging them by failure. The risk of falling into this trap was greatest when the pressures to help pupils achieve results were combined with others, such as shortage of time when he was helping two boys complete their investigation of their own ideas with their bobbin tank.

The difficulties of realising investigative work with pupils are greatest when there is a combination of multiple demands upon the teacher, limited time and resources, uncertainty about what is expected by pupils who work to different reward systems in other parts of the curriculum and outside school, and problems in managing unfamiliar activities with a large class. That description fits the situation of many teachers who are striving to introduce more investigation and problem solving in their

classrooms.

14.3.3 Questions about the nature and learning of investigations and problem solving in science, technology and design

Teachers may welcome support to introduce problem solving and investigation, but see less value in analysing what they are.

The literature review pointed to the need to clarify the concepts of problem solving, design and investigation in primary science and technology. In practice the activities of pupils may be holistic, as the proposals for this component of the National Curriculum recognise.

we recognise that any exploration or investigation - be it a laboratory based experiment, a design and make activity, or an investigation focussing on data collection and the use of secondary sources - can be seen as involving planning, doing and reporting/evaluating outcomes. These processes interlink and overlap and we believe it important to treat investigations/explorations as holistic activities
(DES 1988b, p50)

However teachers do need to distinguish the purposes of the activities and examine their own understanding of what constitute technology and science in primary education. The National Curriculum proposals in fact offer a useful starting point for such an examination as they contain a succinct statement of a view of the nature of science and the nature of technology, and how they are closely linked yet distinctive. Teachers need to look critically at prescribed models of the process of design or investigation or problem solving, as the teacher began to in the course of this study. In particular the view that a general

problem solving process can be taught, noted in passing by the teacher as he reviewed his theories about learning in science (12/6/84-WN), should not be accepted uncritically. The literature review indicated that the evidence emerging from psychology on the learning of problem solving has not yet had much influence in primary science. Nor has there been widespread use of what psychology has to say about the learning of skills and attitudes. This was surprising given the stress on teaching processes which has been a characteristic feature of primary science.

14.4 Primary Science: Learning and Teaching Scientific Ideas

Teachers' thinking also needs to be informed by the growing literature on how the ideas which pupils bring to lessons affect their interpretation of investigations and experiences. Smith and Neale (1987) suggest that primary teachers are rarely aware of pupils' preconceptions and how they can interfere with science learning, and make little use of strategies for changing concepts.

The teacher's emphasis in this case was on the learning of skills and attitudes. He denied that he felt any tension between teaching processes and concepts in the topic under study. However the data revealed a number of difficulties in teaching for understanding within investigations. The first was simply the limited time and attention available. The teacher planned to

teach much of the knowledge and scientific concepts "incidentally" and anticipated lots of opportunities for doing this. In practice there was less use made of those opportunities than intended, as he noted with reference to ideas of structure and rigidity in his final evaluation. There were short individualised interactions and occasional class discussions over the term about scientific ideas connected with the topic under investigation, but only one deliberate planned session with the whole class (on trajectories). He also felt that his class discussions had been too short and less effective than usual in probing and extending pupils' ideas. These difficulties might be attributed to the limitations of time and the conflicting demands of classroom teaching. However teachers do manage to perform multiple functions; indeed the performance of the experienced teacher is characterised by the combination of different demands and goals. What they need now is a basis for teaching understanding and inquiry so they support rather than exclude one another. Although the debate about what should be taught has moved beyond the opposition of process and content, as noted in Chapter 3, primary teachers and science educators have still to articulate the relationship between the learning of process skills and concepts in classrooms. Detailed research and professional development is urgent. A number of issues identified in the present study need to be addressed:

1. the potential of different tasks for developing particular skills and ideas;

2. the combinations of activity and discussion which can promote conceptual learning;
3. what roles teachers should take in open-ended inquiry by pupils;
4. the extent to which the teaching of concepts should be systematic and planned, rather than incidental, or based on individual responses to common experiences;
5. the interaction of children's existing ideas with teaching;
6. how teachers can draw upon their own scientific knowledge to promote the construction of common understanding by their pupils;
7. the need for teachers to review their underlying theories of learning and teaching and to take a research stance toward their own practice.

14.4.1 The potential of different tasks

Harlen (1985a) has described how different topics may be appropriate for developing particular skills such as raising questions, generating hypotheses or seeking patterns. The

present study has illustrated how the setting and mediation of tasks can influence what is learnt from any particular selection of activities in a topic. Thus an activity with model mangonels could promote either designing, construction, control of variables in tests, or understanding of forces and energy. Teachers need not only to be able to draw upon a repertoire of activities so they can select those most suitable for the intended learning but also to recognise the alternative ways in which each might be set and interpreted. To build such a repertoire requires extensive experience and reflection. This process can begin during initial or in-service teacher education but in either case it will need long-term support. Curriculum materials and tutors or advisers can help teachers recognise the scientific potential of familiar topics, identify a range of activities through which their pupils could work toward any attainment target, and make more informed selections. In the early stages that help may need to be in the form of quite specific guidance on the choice and setting of tasks.

14.4.2 The combination of activity and discussion

The emphasis on process and investigation in primary science has been associated with the advocacy of practical activity by pupils. Now there is growing recognition of the need for children to articulate and share their ideas with their peers and teachers. In the next few years a careful balance will have to

be struck to encourage the spread of active investigation while incorporating more deliberate discussion. The practical difficulties of combining the two within the constraints of time and classroom life were seen in the present case. Nor is it simply a matter of deciding whether to leave pupils to continue a practical activity or to hold a discussion. The options of whole class question and answer sessions, pupils reporting to the rest of the class, small group discussion, and individual tutoring are all available; each of these can serve a distinctive purpose in promoting children's scientific understanding and have to be used strategically.

14.4.3 Teachers' roles during pupils' inquiry

If they are to foster understanding while their pupils are pursuing their own ideas and inquiries teachers will need to reflect upon the roles they adopt. Both extremes of a 'laissez-faire' stance or taking control of the investigation to ensure a predictable result are unlikely to lead to optimum learning. Teachers will have to make decisions about when to help pupils clarify their own ideas, translate those into testable questions, carry through an investigation, cope with failure, interpret and evaluate their findings, and when it is appropriate to explore and extend a pupil's knowledge and understanding. Sensitivity is necessary to distinguish 'teachable moments' from times when the child should be allowed to pursue an idea without intervention. Skills in observing,

questioning and answering pupils are crucial to realise the potential of such unplanned interactions.

14.4.4 Systematic teaching of concepts or unpredictable, individual learning

In this case the teacher contrasted the systematic teaching of scientific concepts appropriate in secondary school with his role in primary science of giving the pupils a wide range of experience from which each child would begin to make sense of science. He emphasised individual differences in how children would relate the experiences and ideas they encountered and suggested that for many the process was something of a "lucky bag but at its best it's a patchwork quilt" (15/6/84 TW). His reflections encapsulated the tension between the unpredictable, individualised nature of concept learning and the teacher's responsibility "to plan activities and experiences that are connected". That responsibility has now been formalised within a framework of scientific knowledge and understanding that identifies a range and sequence of attainments toward which teachers should lead their pupils. However the proposals for that framework are qualified by the recognition that

while we have set our statements of attainment for those targets, children's scientific knowledge and understanding may often develop in a rather different way ... Different children will move through the levels in different ways. (DES, 1988b, p16)

Children's learning will continue to be individualised and uneven

despite the specification of a common logical map of the concepts. This is not however any justification for unplanned or unsystematic teaching. Rather it points to the importance of knowing about children's existing ideas as well as the subject matter.

14.4.5 The interaction of children's existing ideas with teaching

Primary teachers are particularly well placed to identify and respond to the ideas of the children in their classes as they work with them over a year in a variety of ways. Emerging evidence of common alternative conceptions among children is more likely to influence classroom practice if teachers become familiar with strategies for teaching conceptual change as well as eliciting children's ideas. Some projects are introducing teachers to this approach and exploring strategies with them (eg Harlen, nd; Smith and Neale, 1987). The incorporation of these approaches in initial teacher education and in-service courses can influence practice in the long term. However the detailed working out of how particular activities and teaching strategies interact with the ideas of individual pupils requires reflective practice by their teacher. Professional knowledge can be extended further through cumulation of action-research and case study by practitioners.

14.4.6 Teachers' use of their own scientific knowledge

The majority of primary teachers lack confidence in their own knowledge of science. The teacher in this case was one of a minority who had studied science in any depth. In the next few years there will be increasing demand for primary teachers and student teachers to enhance their own understanding in those aspects of science they are required to teach. However the present case study provides no support for supplying that knowledge in isolation; rather it points to the importance of helping teachers relate that subject knowledge to their growing skill and understanding in pedagogy as they construct what Shulman has termed pedagogical content knowledge (Wilson, Shulman and Richert, 1986). This help could be given through courses which combine study of the subject with practice in classrooms, through distance learning materials or consultancy. Teachers will need to explore their own ideas through practical activity, discuss them and reflect upon their knowledge and their underlying theories. The present study suggests that such reflection can begin from problems of practice and dilemmas identified by a teacher.

14.4.7 Underlying theories of teaching and learning

Underlying these issues in science teaching are general questions for primary education concerning the contribution to learning of experience, active use of ideas and skills, language and interaction with others. Teachers will have to reconsider their

general theories about learning and teaching if they pursue these issues about the specific subject. A recent study by Edwards and Mercer (1987) illustrated how analysis of dialogues with groups of pupils involved in an investigation can lead to fundamental questions about a prevailing ideology and view of learning. Edwards and Mercer suggest that the achievement of more "principled understanding" rather than "ritual/procedural learning" requires not only a change in practice based on a revised view of learning but also a shift in ideology leading to

a greater emphasis on the importance of language and communication in creating a shared conceptual sense of the meaning and significance of experience and activity (p169)

Such questioning of deeply held theories may arise from the reflective practice of teachers, extended and supported in the sorts of collaborative action research noted above. Primary science may be particularly well placed for this venture, and the study of children's thinking is particularly appropriate as a focus. We need to build links between our understanding of teachers' thinking and of pupils thinking. Teachers of primary science have the opportunity to study their own practice and thinking in the process of encouraging their pupils' scientific understanding. As in the present case, both teacher and pupils can tackle the problems they identify and extend their own knowledge through investigation.

If a teacher can adopt the role in her classroom of a keen and interested learner wanting to find out more about the world, if she can listen to, value and devise ways to check out her own and her pupils' ideas, and can encourage her pupils to do the same; if she can become a researcher both

in terms of finding out about things around and in terms of finding ways to improve classroom practice, then science will take its place in the primary school curriculum. (Harlen and Osborne, 1985, p155)

14.5 Professional Development and In-Service Education

This final section discusses some specific implications for the development of individual teachers and for providers of in-service who seek to promote such development.

The picture of professional development suggested in this study is one in which knowledge and beliefs are constructed and tested by a combination of action and reflection on action. This personal activity needs to be valued as a source of professional theory. In teacher education the activity should be combined with theorising based on empirical research and theorising which examines more general ideas, as argued by Alexander (1984) who also pointed out that the polarisation of 'personal' and 'professional' knowledge in teaching is misleading.

The aspects of a teacher's development which are regarded here as making it 'professional' are those which provide a sounder basis for practice to serve the clients of the teaching profession and to meet the challenges of accountability and change. Cumming et al (1988) present a similar view on the basis of their project on staff development in secondary schools, and summarise the process of professional development as increasing the capacity to respond

to change through

an interactive series of actions involving recognition of a problem in practice (and hence a dilemma and need for response), change in practice, change in understanding of that practice, and exploration of the context (school, curriculum, society, etc) for practice (Cumming, Kidd, Wright, and McIver, 1988, p49)

This approach to professional development can begin in initial teacher training as well as being adopted in work with experienced teachers to encourage a more reflective teaching profession (for example see Pollard and Tann, 1987). However different strategies may be appropriate at the various stages in a teacher's career. For instance student teachers have little practical experience and limited repertoires of professional knowledge and beliefs on which to draw or about which to reflect. There are implications for the articulation of those elements in course design and for the underlying conceptions of the theory-practice relationship held by course planners and legislators. Whether the approach is being adopted in initial or in-service work it is necessary, but not sufficient, to provide opportunities for teachers to relate their practice, theories and different sorts of knowledge. They also need to extend the skills which enable them to do this. Calderhead (1988), drawing on his own studies with student teachers, has identified these as metacognitive skills and hypothesised that over and above them lies

a further organising structure which has some influence over how knowledge is developed and used. This is the conception that students have of the process of learning to teach. (Calderhead, 1988, p61)

Within such a picture of knowledge use by teachers their professional development would require conditions which gave them insight into their own learning and increasing responsibility for the process. The teacher in this case was committed to examining his own practices and thinking, and was able to act upon his own analysis. These sort of internal conditions have been posed as four questions by Russell (1980):

1. Has the teacher an analytical perspective on his/her own teaching?
2. Is the analysis based on rational authority?
3. Do the results permit the teacher to plan alternative practices?
4. Is the teacher prepared to deal with the responses to those?

In addition the teacher needs confidence, time, freedom and support. The critical examination of one's own practice is not always a comfortable process, especially where this involves new teaching approaches or subject matter. Teachers introducing problem solving in science or technology for the first time may be too vulnerable to research their own practice! They may rightly be concerned with coping, and outsiders or colleagues who work with them should recognise their needs for practical help and success at this stage - but see this also as building the confidence to question their practice subsequently. In the present case the teacher was confident as a person and as a classroom teacher, and experienced in the subject under study; he was able to try new approaches and to examine his teaching. He

also had the freedom to make choices about this teaching and the pupils' activities, and felt it possible to allow the time for the more exploratory work. Primary teachers rarely feel there is enough time to attend to the needs of their pupils and the wide curriculum; if they are to be actively involved in the sort of professional development under discussion then time will have to be made available. This is not simply a claim for non-contact time, but for co-ordinated use of time to focus on aspects of practice in and out of the classroom.

In discussing the Focus on Teaching Project, which was concerned with staff development in Scottish primary schools, Cameron-Jones (1988) stressed that the question of time should not be construed grossly in terms of the amounts needed, but in terms of its organisation and the related facilitation or support. This may be organised in a number of ways - eg by systematic use of supply teachers, shared teaching, support by headteachers and advisory staff, and INSET. The sort of support that teachers will need to engage in research has been discussed above. The Focus model of staff development identified levels of commitment from more reflective teaching to action-research. In managing staff development and planning INSET it is necessary to provide support and motivation for teachers at all levels, not simply those who are already committed to researching their own practice.

Courses and staff development programmes need then to follow the general maxim of beginning where the learner is, and to recognise

the particular characteristics of their adult learners. This can be done by starting with the problems and dilemmas which concern teachers, but also by identifying those which they will have to face. They need to be challenged, but not threatened. They need to feel that the process is relevant to their more immediate classroom concerns. A dialogue and commitment have to be established if they are then to be asked to question their practices. The teacher in this case expressed his frustration that many of his colleagues in the LEA were unwilling to pursue those questions. While recognising that some teachers may remain what Cumming et al (1988) term 'reluctant starters' who are left passive and 'basking' by INSET, it is important that staff development does not become an activity for a minority of 'self-starters'. It should also be seen as a long term task for teachers, supported by management and providers of in-service through programmes which combine action and thinking appropriately for the needs of the individuals at the time. As an example consider courses for teachers who are responsible for science in their primary schools, run by many of us in higher education in recent years following DES initiatives. We have had to provide course members with confidence and competence in science teaching and a basis for their consultancy and curriculum development work with colleagues. The scientific backgrounds and experience of staff development among members has varied enormously. The courses have sought to meet some of the immediate needs and problems that members felt, to build a climate in which more fundamental questions could be posed, to

combine action in school and reflection upon that action with colleagues and tutors who could support and challenge, and to develop skills of analysis and reporting. This had to be a negotiated process. It had to be seen as part of a longer term development for the schools and the individuals involved, planned ahead in collaboration with LEA advisory services and headteachers, implemented through systematic movement between action and reflection over a year, and followed up with support and evaluation. Evaluation of one such course (Smith, 1988) revealed that the extent to which it proved possible for members to move from immediate concerns to a research-based approach to their teaching was influenced by the constraints identified earlier in this chapter, as well as by individual differences.

Opportunities for professional development have arisen in initiatives such as those courses, and in some of the changes in teachers' conditions of service and in-service funding in the years following the present study. Credit for professional activities and more flexible provision in higher education may offer individualised routes for committed teachers. On the whole however the centralisation of control in education and the climate created by pay disputes, noted as features in the background of this case, have not been sympathetic to the needs of individual teachers for professional development. The introduction of a National Curriculum will impose a new framework for staff development in primary schools. If time and support are provided for programmes of study to be properly piloted and

for teachers to reflect upon their practice then the changes could stimulate extensive professional learning. However the pace and constraints imposed on in-service training and the emphasis on assessment and accountability may lead teachers to adopt coping strategies. Curriculum developers and researchers should seek to collaborate with teachers to discuss the dilemmas they face in implementing the science curriculum. That collaboration could help science education address the issues identified in section 14.4 above and also encourage teachers to review their thinking and practice. It should contribute to the construction of a sounder knowledge base for the profession and provide opportunities for the professional development of individual teachers.

The teaching profession will certainly need to seize what opportunities there are for extended and appropriate professional learning. For example primary teachers urgently need to develop a knowledge base for teaching and assessing in science; they should demonstrate that this involves more than acquiring subject knowledge. Berliner (1987) has noted that his studies with secondary teachers contradict any assumptions policy makers may have that subject matter content knowledge is sufficient for teaching mathematics or science. Smith and Neale (1987) suggested that earlier curriculum innovations failed to recognise the complexity of the knowledge required for good science teaching. The present study of a primary teacher with a scientific background does not provide any support for the

argument that more knowledge of a subject by itself is a source of better practice by teachers or learning by their pupils. Rather it suggests that it is the extended and reflective use of that knowledge in the service of a view of learning which creates a basis for improved practice. The concept of a repertoire developed in the present study offers a tool for building and explaining the professional knowledge base which teachers need. It conveys the personal and practical orientation of professional development, the movement between theories and plans and classroom action, the range of knowledge and skills which are needed and the variety of ways in which that can be used. This supports the argument that teachers are professionals who do not merely apply technical solutions or carry out instructions, and whose personal development needs to be sustained to improve the quality of practice in a changing society. Cumming et al (1988) identified a similar message from their research into staff development.

the outcome of the research - the message if you like - was that, fundamentally, professional staff development is concerned with increasing the capacity of teachers, individually and collectively, for change. (p48)

Change is then a goal, a reason and an opportunity for professional development. It may act as a spur to the 'reluctant starter'. For teachers like the one in this study, who already look to their own problems of practice as a source of growth, it offers a further challenge which requires them to examine their ideologies and theories as well as their plans and classroom practice. Like their pupils, teachers need opportunities to

investigate, support to solve their problems, and challenges to their thinking. Primary science is particularly rich in such opportunities, problems and challenges as it becomes established at the core of the National Curriculum.

BIBLIOGRAPHY

- Adams, R and Preiss, J (eds) (1960) Human Organisation Research: Field Relations and Techniques Homewood Illinois: Dorsey Press
- Adelman, C, Kemmis, S and Jenkins, D (1980) Rethinking Case Study - Notes from the Second Cambridge Conference, in Simons (ed) Towards a Science of the Singular Norwich: CARE p45-61
- Aikenhead, G.S. (1984) Teacher decision making: the case of Prairie High Journal of Research in Science Teaching, 21,2,167-186
- Alexander, RJ (1984) Primary Teaching Eastborne: Holt, Rinehart and Winston
- Anning, A (1988) An analysis of six primary teachers' understanding of how children learn and its relationship to their teaching strategies, in Calderhead (ed) Teachers' Professional Learning London: The Falmer Press p128-145
- APU (1978) Science Progress Report 1977-78. Appendix: List of Science Concepts and Knowledge London: DES
- Argyris, C and Schon, DA (1974) Theory in Practice; Increasing Professional Effectiveness San Francisco: Jossey-Bass
- ASE (1983) Primary Science Newsletter Autumn 1983, p2-3
- Atkinson, P and Delamont, S (1986) Bread and dreams or bread and circuses? A critique of 'case study' research in education, in Hammersley, M (ed), The Ethnography of Schooling: Methodological Issues Driffield: Nafferton Books p238-254
- Ball, SJ (1983) Case study research in education: some notes and problems, in Hammersley, M (1983) (ed) ch5
- Ball, SJ (1984) Beachside reconsidered, in Burgess RG (ed) The Research Process in Educational Settings: Ten Case Studies Lewes: The Falmer Press p69-96
- Barnes, D (1983) Curriculum developers versus teachers' dilemmas Studies in Science Education, 10, p 129-135
- BBC (1982) Junior Craft, Design and Technology (Teachers' Booklet for TV Series) London: BBC
- Becker, HS and Geer, HA (1960) Participant observation: the analysis of qualitative field data, in Adams, R and Preiss J (eds) Human Organisation Research: Field Relations and Techniques Homewood Illinois: Dorsey Press
- Bell, GH (1982) Information technology and teacher research, in Elliott, J and Ebbutt, D (eds) Facilitating Educational Action Research in Schools London: Longmans

- Bell, G (1985) Can schools develop knowledge of their practice? School Organisation, 5,2, pp 175-184
- Berlak, A et al (1975) Teaching and learning in English primary schools, School Review, 83,215-43, reprinted in Hammersley, M and Woods, P (eds) (1976) The Process of Schooling London: Routledge, Kegan and Paul
- Berliner, DC (1987) Ways of thinking about students and classrooms by more and less experienced teachers, in Calderhead (ed) Exploring Teachers' Thinking London: Cassell Educational p66-73
- Ben-Peretz, M, Bromme, R and Halkes, R (eds) (1986) Advances of Research in Teacher Thinking Lisse: ISATT, Swets and Zeitlinger
- Black, P and Harlen, W (1982) Signposts for primary science Times Educational Supplement 24 September 1982
- Bogdan, R and Taylor, S (1975) Introduction to Qualitative Research Methods. A Phenomenological Approach to the Social Sciences New York: John Wiley & Sons
- Bolton, E (1984) In a talk to the National Association for Primary Education, reported in Times Educational Supplement, 18 May 1984
- Bromme, R (1984) On the limitations of the theory metaphor for the study of teachers' expert knowledge, in Halkes and Olson (eds), Teacher Thinking: a New Perspective on Persisting Problems in Education Lisse: Swets and Zeitlinger, p43-57
- Brook, A and Driver, R in collaboration with Hind, D (1988) The Development of Pupils' Understanding of Physical Characteristics of Air, Across the Age Range 5 to 16 Years Children's Learning in Science Project, Centre for Studies in Science and Mathematics Education, University of Leeds
- Burgess, R (ed) (1982) Field Research: a Sourcebook and Field Manual London: Allen and Unwin
- Burgess, R (ed) (1984a) The Research Process in Educational Settings: Ten Case Studies Lewes: The Falmer Press
- Burgess, R (1984b) In the Field. An Introduction to Field Research London: George Allen & Unwin
- Burgess, R (ed) (1985a) Field Methods in the Study of Education Lewes: The Falmer Press
- Burgess, R (ed) (1985b) Strategies of Educational Research: Qualitative Methods Lewes: The Falmer press
- Bussis AM, Chittenden EA, Amarel M (1976) Beyond Surface Curriculum. An Interview Study of Teachers' Understandings Boulder, Colorado: Westview Press
- Butt, RL (1984) Arguments for using biography in understanding teacher thinking, in Halkes and Olson (eds) Teacher Thinking: New Perspectives on Persisting Problems in Education Lisse: Swets and Zeitlinger

- Calderhead, J (1981) Research into teachers' and student teachers' cognitions: Exploring the nature of classroom practice British Educational Research Journal 1981, 7, 51-57
- Calderhead, J (1984) Teachers' Classroom Decision Making London: Holt, Rinehart and Winston
- Calderhead, J (1986) Developing a Framework for the Elicitation and Analysis of Verbal Reports Paper presented at the American Educational Research Conference, San Francisco, 1986
- Calderhead, J (ed) (1987a) Exploring Teachers' Thinking London: Cassell Educational
- Calderhead, J (1987b) Teacher and student cognitions. American Educational Research Association Special Interest Group Newsletter No. 6.1 Calderhead, University of Lancaster, Dept Educational Research
- Calderhead, J (ed) (1988) Teachers' Professional Development London: The Falmer Press
- Calderhead, J and Miller, E (1985) The Integration of Subject Matter Knowledge in Student Teachers' Classroom Practice Paper presented at B.E.R.A. Conference, Sheffield, September 1985 (subsequently published by School of Education, University of Lancaster, 1986)
- Cameron-Jones, M (1988) Teaching better in primary schools, in Gatherer (ed) The Quality of Teaching Special Issue of the Scottish Educational Review, Edinburgh: Scottish Academic Press
- Campbell RJ (1985) Developing the Primary School Curriculum Eastborne: Holt, Rinehart and Winston
- Carter, K and Doyle, W (1987) Teachers' knowledge structures and comprehension processes, in Calderhead (ed) p 147-160 Exploring Teachers' Thinking London: Cassell Educational
- Central Advisory Council for Education (England) (1967) (The Plowden Report) Children and their Primary Schools. Vol 1 London: H.M.S.O.
- Champagne, AB and Klopfer, LE (1981) Problem solving as outcome and method in science teaching: Insights from 60 years of experience, in School Science and Mathematics, 8, p3-8, Jan 1981
- Clandinin, DJ (1986) Classroom Practice. Teacher Images in Action Lewes: The Falmer Press
- Clandinin, DJ and Connelly, M (1986) What is "personal" in studies of the personal, in Ben-Peretz, Bromme and Halkes, p 21-35 Advances of Research in Teacher Thinking Lisse: ISATT, Swets and Zeitlinger
- Clandinin, DJ and Connelly, FM (1987) Teachers' personal knowledge: what counts as "personal" in studies of the personal J Curriculum Studies, 19, (6) Nov-Dec 1987, p487-500

Clark, CM (1980) Choice of a model for research on teacher thinking
J Curriculum Studies, Vol 12, No1, 41-47

Clark, CM (1983) Research on Teacher Planning: An Inventory of the Knowledge Base Occasional Paper No. 66 East Lansing, MI: Institute for Research on Teaching, Michigan State University

Clark, CM (1986) Ten years of conceptual development in research on teacher thinking, in Ben-Peretz, M Bromme, R and Halkes, R (eds) Advances of Research in Teacher Thinking, Lisse: ISATT, Swets and Zeitlinger

Clark, CM and Peterson PL (1983) Teachers' Thought Processes Paper at ISATT symposium, Tilsburg, 1983 subsequently published in Wittrock MC (ed) Handbook of Research on Teaching New York: MacMillan, p225-296

Clark CM and Yinger RJ (1979) Three Studies of Teacher Planning Research Series No 55. East Lansing Michigan: Institute for Research on Training

Clark, CM and Yinger, RJ (1980) The Hidden World of Teaching: Implications of Research on Teacher Planning Research series No 77. Michigan: Institute for Research on Teaching, Michigan State University

Clark, CM and Yinger, RM (1987) Teacher Planning, in Calderhead, J (ed) Exploring Teachers' Thinking, London: Cassell Educational, p84-103

Claxton, G (ed) (1980) Cognitive Psychology. New Directions London: Routledge and Kegan Paul

C.L.I.S.P. (1987) Development of Understanding (5-16 years) Interim Report Children's Learning in Science Project, December 1987

Cohen, L and Manion, L (1985) Research Methods in Education (second edition) London: Croom Helm

Connelly, FM and Clandinin, DJ (1984) Personal practical knowledge at Bay Street, ritual, personal philosophy and image in Halkes and Olson Teacher Thinking: a New Perspective on Persisting Problems in Education Lisse: Swets and Zeitlinger

Cornwall LEA (1987) Primary Science Guide lines for Cornish Schools Cornwall LEA

County of Avon 1986) Primary Science Working Paper 3: An Approach through Problem Solving County of Avon LEA

Cumming, C, Kidd, J, Wight, J and Molver, J (1988) The quality of teaching as response, in Gatherer (ed) The Quality of Teaching Specialissue of the Scottish Educational Review, Edinburgh: Scottish Academic Press, p48-53

Delamont, S (1976) Interaction in the Classroom London: Methuen

Delamont, S and Hamilton, (1986) Revisiting classroom research: a continuing cautionary tale, in Hammersley, M (ed) Controversies in Classroom Research Milton Keynes: Open University Press p25-43

Denscombe, M (1983) Interviews, accounts and ethnographic research on teachers, in Hammersley, M (ed) The Ethnography of Schooling: Methodological Issues Driffield: Nafferton Books, p107-125

DES (1978) Primary Education in England: A Survey by HM Inspectors of Schools London: HMSO

DES (1981) Science in Schools. Age 11 APU Report No 1 London: HMSO

DES (1983a) Science in Primary Schools A discussion paper produced by HMI Science Committee London: DES

DES (1983b) Science in Schools. Age 11 APU Report No 2 London: DES

DES (1984) Science in Schools. Age 11 APU Report No 3 London: HMSO

DES (1985a) Science 5-16: a Statement of Policy London: DES and the Welsh Office

DES (1985b) Science in Schools. Age 11 Report No 4 London: DES

DES (1987) The National Curriculum 5-16. A Consultation Document London: DES and the Welsh Office, July 1987

DES (1988a) National Curriculum Science Working Group Interim Report (January 1988) London: DES and the Welsh Office

DES (1988b) Science for Ages 5 to 16. Proposals of the Secretary for State for Education and the Secretary of State for Wales (August 1988) London: DES and the Welsh Office

Desforges, C and Cockburn, A (1987) Understanding the Mathematics Teacher. A study of practice in first schools Lewes: The Falmer Press

Design Council Primary Education Working Party (1986) Design and Primary Education London: The Design Council

Donaldson, M (1978) Children's Minds London: Fontana

Doyle (1979) Classroom tasks and student abilities, in Peterson, PL and Walberg, HJ (eds) Research on Teaching: Concepts, Findings and Implications Berkeley California: McCutchan

Doyle, W (1986) Classroom organisation and management, in Wittrock Handbook of Research on Teaching New York: MacMillan, p342-431

Driver, R (1983) The Pupil as Scientist? Milton Keynes: Open University Press

Driver, R and Oldham, V (1988) A Constructivist Approach to Curriculum Development in Science Paper presented at British Educational Research Association Annual Conference, Sheffield, August 1985

- Duffy, GG (1981) Theory to Practice: How Does it Work in Real Classrooms? Research Series No 98 Michigan: Institute for Research on Teaching, Michigan State University
- Ebbutt, D (1983) Educational Action-Research: some general concerns and specific quibbles Cambridge: Cambridge Institute of Education
- Ebbutt, D (1985) Educational Action-Research: some general concerns and specific quibbles in Burgess, RG (ed) (1985c)
- Edwards, D and Mercer, N (1987) Common Knowledge: the Development of Understanding in the Classroom London: Methuen
- Eggleston, J (ed) (1979) Teacher Decision Making in the Classroom London: Routledge & Kegan Paul
- Elbaz, F (1983) Teacher Thinking: a Study of Practical Knowledge New York: Nicholls Publishing Co.
- Elliott, J and Partington, D (1975) Three Points of View in the Classroom: Generating Hypotheses from Classroom Observations, Recordings and Interviews Norwich: Centre for Applied Research in Education, University of East Anglia
- The Engineering Council / SCSST (1985) Problem-Solving: Science and Technology in Primary Schools London: The Engineering Council / SCSST
- Ennever, L and Harlen, W (1972) With Objectives in Mind: Guide to Science 5-13 London: MacDonal Educational
- Erickson, GL (1987) Constructivist Epistemology and the Professional Development of Teachers Paper presented at the anual meeting of the American Educational Research Association, Washington DC, April 1987
- Evans, P (1980) Science: pure or applied? in Education 3-13, 8, 1, pp:16-23
- Ford Teaching Project (nd) Unit 1 Patterns of Teaching Primary School Science Unit 4. Teacher Case Studies. Inquiry / Discovery Learning in a Science Project, and The China Project Norwich: Centre for Applied Research in Education, University of East Anglia
- Gagné et al (1967) Science: A Process Approach: purposes, accomplishments, expectations Washington: American Association for the Advancement of Science (AAS Miscellaneous Publication 67-12)
- Galton, M and Willcocks, J (ed) (1983) Moving from the Primary Classroom London: Routledge & Kegan Paul
- Gilbert, C (1987a) A Guide to Primary Technology Policy Edinburgh: Oliver and Boyd

Gilbert, C (1987b) In the primary science and technology glasshouse, in Primary Science Review, 3, p 25

Gilbert, C and Matthews, P (1981-84) LOOK! Teachers Guide - and work cards Edinburgh: Oliver and Boyd (formerly Addison-Wesley)

Gilbert, C and Matthews, P (1984) A Guide to Primary Science Policy Edinburgh: Oliver and Boyd (formerly Addison-Wesley)

Glaser, BG and Strauss, AL (1976) The Discovery of Grounded Theory: Strategies for Qualitative Research New York: Aldine

Goetz, JP and LeCompte, MD (1984) Ethnography and Qualitative Design in Educational Research New York: Academic Press (Harcourt Brace Jovanovich)

Goodson, I (1983) The use of life histories in the study of teaching, in Hammersley, M (ed), The Ethnography of Schooling: Methodological Issues Driffield: Nafferton Books, ch 7

Guba, EG and Lincoln, YS (1981) Effective Evaluation: Improving the Usefulness of Evaluation Results Through Responsive and Naturalistic Approaches San Francisco: Jossey-Bass

Halkes, R (1986) Teacher thinking: a promising perspective into educational processes. Report of the 1983 and 1985 conferences of ISATT J. Curriculum Studies, 18, 2, p 211-214

Halkes, R and Deijkers, R (1984) Teachers' teaching criteria, in Halkes and Olson (eds) p149-162

Halkes, R and Olson, JK (eds) (1984) Teacher Thinking: a New Perspective on Persisting Problems in Education Proceedings of the first symposium of the International Study Association on Teacher Thinking, Tilburg, October 1983 Lisse: Swets and Zeitlinger 1984

Hamilton, D and Delamont, S (1974) Classroom research: a cautionary tale? Research in Education, 11, p1-15 (reprinted in Stubbs, M and Delamont, S (eds) (1976) Explorations in Classroom Observation, Chichester: John Wiley)

Hammersley, M (ed) (1983) The Ethnography of Schooling: Methodological Issues Driffield: Nafferton Books

Hammersley, M (1984) The researcher exposed: a natural history, in Burgess, RG (ed) The Research Process in Educational Settings: Ten Case Studies Lewes: The Falmer Press p 39-68

Jenkins, E and Whitfield, R (1974) eds Readings in Science Education (Science Teacher Education Project) London: McGraw Hill

Johnsey, R (1986) Problem Solving in School Science MacDonald Educational

Hammersley, M (ed) (1986) Controversies in Classroom Research Milton Keynes: Open University Press

Hammersley, M and Atkinson, P (1983) Ethnography. Principles in Practice London: Tavistock

Hargreaves, DH (1979) A phenomenological approach to classroom decision-making, in Eggleston, J (ed) Teacher Decision Making in the Classroom London: Routledge Kegan and Paul, p74-81

Harlen, W (1978) Does content matter in primary science? School Science Review, 59, pp 614-25

Harlen, W (ed) (1983a) New Trends in Primary School Science Education Vol. 1. Paris: UNESCO

Harlen et al (1983b) Science at Age 11 Assessment of Performance Unit Science Report for Teachers: 1. London: DES

Harlen, W (1985a) Teaching and Learning Primary Science London: Harper & Row

Harlen, W (1985b) Primary Science: Taking the Plunge London: Heinemann Educational

Harlen, W (1986) Planning Scientific Investigations at Age 11 A.P.U Science report for teachers: 8 London: DES

Harlen, W (nd) What is Going on in Space? An Introduction to the Science Processes and Concept Exploration Project Centre for Research in Primary Science and Technology, Department of Education, University of Liverpool

Harlen, W and Osborne, R (1983) Toward a Teaching Model for Primary Science S.E.R.U., University of Waikato, Hamilton NZ

Harlen, W and Osborne, R (1985) A model for learning and teaching applied to primary science J. Curric Studies, 17, 2, April-June 1985

Hopkins D (1985) A Teachers Guide to Classroom Research Milton Keynes: Open University Press

Isaacs, N (1958) Early Scientific Trends in Children London: National Froebel Foundation

Isaacs, N (1962) The case for bringing science into the primary school, in Richards and Holford The Teaching of Primary Science: Policy and Practice Lewes: The Falmer Press, p105-112

Jackson, P (1968) Life in Classrooms New York: Holt, Rinehart and Winston

Janesick, V (1977) An Ethnographic Study of a Teacher's Classroom Perspective Unpublished doctoral dissertation, Michigan State University, 1977

James, A (1977) Active Science Huddersfield: Schofield and Sims

- Johnson, RT (1983) Elementary Science: a desired state in, Penick, JE Focus on Excellence Vol 1 No 2 Elementary Science Washington DC: National Science Teachers Association, Ch 1
- Joyce, B (1980) Toward a Theory of Information Processing in Teaching Research Series No. 76. East Lansing, Michigan: Institute for Research on Teaching, College of Education Michigan State University
- Kelly, GA (1955) The Psychology of Personal Constructs. Volumes 1 and 2 New York: Norton
- Kemmis, S (1980) The imagination of the case and the invention of the study, in Simons, H (ed) Towards a Science of the Singular Norwich: CARE, p93-142
- Kempa, R (1984) Science Education Research: What's the use of it? Talk at Sheffield City Polytechnic, 27 June 1984
- Kenny, WR & Groteleuschen, AD Making the case for case study J. Curriculum Studies, 1984, Vol 16, No.1, 37-51
- Kerr, J and Engel, E (1980) Can science be taught in primary schools? Education 3-13, 8, 1, 1980, pp 4-8
- Keys, W (1987) Aspects of Science Education in English Schools International Studies in Pupil Performance NFER - Nelson
- King, R (1984) The man in the Wendy house: researching infants' schools, in Burgess, RG (ed) The Research Process in Educational Settings: Ten Case Studies. Lewes: The Falmer Press, p117-138
- Krause, F (1986) Subjective theories of teachers: reconstruction through stimulated recall, interview and graphic representation of teacher thinking in Ben-Peretz, Bromme and Halkes (eds) Advances of Research in Teacher Thinking Lisse: ISATT, Swets and Zeitlinger, p159-171
- Lampert, M (1984) Teaching About Thinking and Thinking About Teaching J. Curriculum Studies, Vol.16, No.1, 1-18
- Lampert, M (1985) How do teachers manage to teach? Perspectives on problems in practice Harvard Educational Review, 55, 178-194
- Lampert, M (1986) Teachers' strategies for understanding and managing classroom dilemmas, in Ben-Peretz, M Bromme, R and Halkes, R (eds) Advances of Research in Teacher Thinking Lisse: ISATT, Swets and Zeitlinger, p70-83
- Lowyck, J (1986) Post-interactive reflections of teachers: a critical appraisal in Ben-Peretz, Bromme and Halkes, Advances of research in Teacher Thinking Lisse: ISATT, Swets and Zeitlinger, p172-185
- Lutz, FW (1986) Ethnography: the holistic approach to understanding schooling, in Hammersley, M (ed) Controversies in Classroom Research Milton Keynes: Open University Press

MacDonald, B (1980) Letters from a headmaster, in Simons, H (ed) Towards a Science of the Singular Norwich: CARE, p15-44

MacDonald, B and Walker, R (1975) Case study and the social philosophy of educational research Cambridge Journal of Education, 1975, 5, p 2-11

MacKay, DA and Marland, PW (1978) Thought processes of teachers Paper presented at AERA conference, Toronto, Canada, March 1978

Malinowski, B (1922) Argonauts of the Western Pacific London: Routledge & Kegan Paul

Marland, PW (1977) A Study of Teachers' Interactive Thoughts Unpublished doctoral thesis, The University of Alberta

Marland, PW (1987) Response to Clandinin and Connelly J. Curriculum Studies, 19, 6, p 504-506

Martin, MD (1983) Recent trends in the nature of curriculum programmes and materials, in Harlen New Trends in Primary School Science Education Vol 1 Paris: UNESCO, p55-67

Match and Mismatch (1977) Teachers Guide Edinburgh: Oliver and Boyd

Mayer, RE (1983) Thinking, Problem-Solving, Cognition Oxford: WH Freeman

McCall, GJ and Simmons, JL (eds) (1969) Issues in Participant Observation; A Text and Reader Reading, MA: Addison-Wesley

McClelland, G (1983) Ausubel's theory of meaningful learning and its implications for primary science, in Richards and Holford (eds) The Teaching of Primary Science: Policy and Practice Lewes: The Falmer Press, p113-124

McCutcheon, G (1980) How do elementary school teachers plan? The Nature of planning and influences on it The Elementary School Journal Vol 81, No. 1, p 4-23

McNair, K (1978-9) Capturing inflight decisions: thoughts while teaching, Educational Research Quarterly Vol.3, No.4, Winter 1978-79

Medawar, PB (1967) The Art of the Soluble Harmondsworth: Penguin

Miles, MM and Huberman, AM (1984) Qualitative Data Analysis. A Sourcebook of New Methods Beverley Hills: Sage Publications

Millar, R and Driver, R (1987) Beyond Processes, in Studies in Science Education, 14, p 33-62

Morine-Dershimer, G (1979) Teacher Plan and Classroom Reality. The South Bay Study, Part IV Research Series No 60 Michigan: Institute for Research on Teaching

Morine-Dersheimer, G (1984) Complexity and imagery in teacher thought: alternative analyses of stimulated recall data Paper for AERA meeting, New Orleans, April 1984

Munby, H (1982) The place of teachers' beliefs in research on teacher thinking and decision making, and an alternative methodology Instructional Science II (1982) 201-255

Munby, H (1983) A qualitative study of teachers' beliefs and principles Paper presented at AERA meeting, Montreal, April 1983

Munby, H (1986) Metaphor in the thinking of teachers: an exploratory study J. Curriculum Studies, 18, 2, p 197-209

Nisbett, R and Ross, L (1980) Human Inferences: Strategies and Shortcomings of Social Judgement Englewood Cliffs, N.J. Prentice-Hall

Nuffield Junior Science (1967a) Teachers Guide I London: Collins

Nuffield Junior Science (1967b) Teachers Guide II London: Collins

Olson (1980) Teacher constructs and curriculum change Journal of Curriculum Studies, 12, p 1-12

Olson, J (1982a) Classroom knowledge and curriculum change in Olson, J (ed) Innovation in the Science Curriculum Croom Helm

Olson, J (1982b) Constructivism and education: a productive alliance Interchange, 13, 4, 1982, p 70-75

Olson, J (1984) What makes teachers tick? considering the routines of teaching in Halkes and Olson (eds), Teacher Thinking: a New Prospective on Persisting Problems in Education Lisse: Swets and Zeitlinger p35-42

Olson, J (1988) Making sense of teaching: cognition vs culture J. Curriculum Studies, 1988, 20, 2, p 167-169

Olson, J and Russell, T (eds) (1983) Science Education in Canadian Schools Vol III - Case Studies of Science Teaching A Draft Report of Research Prepared for the Science Council of Canada. Jan 1983

Open University/Schools Council (1980) Curriculum in Action: an Approach to Evaluation Milton Keynes: Open University Press

Orpwood, GWF and Souque JP (1983) Science Education in Canadian Schools Volume I - Introduction and Curriculum Analyses Report of Research Prepared for the Science Council of Canada

Osborne, R (1980) Force Working Paper No 16, Learning in Science Project, University of Waikato, Hamilton, New Zealand

Osborne, RJ, Bell, B and Gilbert, J (1983) Science teaching and children's views of the world European Journal of Science Education, 5, 1, p 1-14

Osborne, R and Freyberg, P (1985) Learning in Science. The Implications of Children's Science Auckland: Heinemann

Osborne, R, Schollum, B and Hill, G (1981) Force, Friction, Gravity. Notes for Teachers Working Paper 33, Learning in Science Project, University of Waikato, Hamilton, New Zealand

Ovens, P and Ryan, J (1984) Towards Investigative Science in a Primary Classroom - a Classroom Action Research Study Paper at Classroom Action Network International conference, Cambridge Institute of Education, November 1984

Patton, MQ (1980) Qualitative Evaluation Methods Beverley Hills: Sage Publications

Penick, JE (ed) (1983) Focus on Excellence Vol I No 2 Elementary Science Washington DC: National Science Teacher's Association.

Peterson, PL (1988) Teachers and students cognitions as mediators of teaching effectiveness, in ISATT Newsletter, No 6, May 1988, p 6-31 Tilburg, Netherlands: ISATT

Peterson, PL Marx, RW and Clark CM (1978) Teacher planning, teacher behaviour, and student achievement, American Educational Research Journal, 1978, 15, 417-432

Peterson, PL and Walberg, HJ (eds) (1979) Research on Teaching: Concepts, Findings and Implications Berkeley California: McCutchan

Pollard, A and Tann, S (1987) Reflective Teaching in the Primary School London: Cassell

Pope, ML (1982) Personal construction of formal knowledge Interchange 13/4, 1982, p 3

Pope, ML and Keen, TR (1981) Personal Construct Psychology and Education Academic Press

Pope, ML and Scott, EM (1984) Teachers' epistemology and practice in Halkes and Olson (eds) Teacher Thinking: a New Perspective on Persisting Problems in Education Lisse: Swets and Zeitlinger, p112-122

Powney, J and Watts, M (1987) Interviewing in Educational Research London: Routledge & Kegan Paul

Presst, B (ed) (1987) Longman Science World Junior Teachers Book Harlow, Essex: Longman

Radford, D (1972) Science from Toys Stages 1 and 2 and Background A unit for teachers in the Science 5/13 Project London: MacDonald Educational for the Schools Council

Radford, D (1974) Science, models and toys Stage 3 A unit for teachers in the Science 5/13 Project London: MacDonald Educational for the Schools Council

Redman, S et al (1969) An Approach to Primary Science London: MacMillan

Richards, C (ed) (1973) Education 3-13, vol 1, no 1

Richards, C and Holford, D (1983) The Teaching of Primary Science: Policy and Practice Lewes: The Falmer Press

Richards, R, Collis, M, Kincaid, D (1985) Learning Through Science Guide and Index London: MacDonald Educational

Roehler, LR, Duffy, GG, Herrmann, BA, Conley, M, Johnson, J (1988) Knowledge structures as evidence of the personal: bridging the gap from thought to practice J. Curriculum Studies, 20, 2, p 159-165

Roth, KJ (1984) Using classroom observations to improve science teaching and curriculum materials, in Anderson, CW (ed) 1984 AETS Yearbook Observing Science Classrooms: Observing Science Perspectives from Research and Practice ERIC/SMEAC pp 77-102

Rudduck, J (ed) (1982) Teachers in Partnership: Four Studies of In-Service Collaboration (Schools Council Programme 2) Longman for Schools Council

Rudduck, J (1985) A case for case records? A discussion of some aspects of Lawrence Stenhouse's work in case study methodology, in Burgess, RG (ed) Strategies of Educational Research: Qualitative Methods Lewes: The Falmer Press, p 101-120

Russell, TL (1980) Developing teachers' analytical skills, in Munby, H, Orpwood, GWF, Russell, TL (eds) Seeing Curriculum in a New Light Essays from Science Education, p 114-125. Ontario: OISE Press / the Ontario Institute for Studies in Education

Schmidt, WH, Porter, AC, Floden, RE, Freeman, DJ & Schwille, JR (1987) Four patterns of teacher content decision making J Curriculum Studies, 19, 5, p 439-455

Schoeneberger, M and Russell, T (1986) Elementary science as a little added frill: a report of two case studies Science Education, 70 (5) October 1986 p 579-538

Schon, D (1983) The Reflective Practitioner New York: Basic Books

Schon, DA (1987) Educating The Reflective Practitioner San Francisco/ London: Jossey Bass

School Natural Science Society (1984) Skills and attitudes for the primary age range, Teaching Science (Journal of the School Natural Science Society), 2, 1, Spring 1984, p i-viii

Shavelson, RJ (1973) The basic teaching skill: decision making Research and Development Memorandum No 104 Stanford, CA: Stanford Centre for Research and Development in Teaching

Shavelson, RJ and Stern, P (1981) Research on teachers' pedagogical thoughts, judgements, decisions, and behaviour Review of Educational Research, Winter, 1981, 51, 4, 455-498

Shulman, LS (1986) Those who understand: knowledge growth in teaching Educational Researcher, 15, p 4-14

Simons, H (ed) (1980) Towards a Science of the Singular, Occasional Publication No 10, Norwich: Centre for Applied Research in Education, University of East Anglia

Simons, H (1981) Conversation piece: the practice of interviewing in case study research in Adelman, C (ed) Uttering, Muttering: Collecting Using and Reporting Talk for Social and Educational Research London: Grant McIntyre

Smith, RG (1988) Why not research your practice? Some problems and opportunities for teachers of primary science Sheffield Educational Research, Current Highlights, October 1988

Smith, EL and Anderson, CW (1983) The Planning and Teaching Intermediate Science Study: Final Report Michigan: Institute for Research on Teaching

Smith, DC and Neale, DC (1987) The Construction of Expertise in Primary Science: Beginnings Paper presented at the Annual Meeting of the American Educational Research Association, Washington DC, April 1987

Smith, EL and Sendelbach, NB (1982) The programme, the plan and the activities of the classroom: the demands of activity-based science in Olson, J (ed) 1982 Innovation in the Science Curriculum pp 72-106 London: Croom Helm

Smith, RG, Stead, D and Wilkinson, J (1985) Clues: Science in an Integrated Topic Topics in Primary Science, 1, Sheffield: Pavic Publications

Squires, A (1976) A.S.E. Study Series No 6: Science in the Middle Years Hatfield: ASE

Squires, A (1980) Core Intentions for Science in the Middle Years Leeds City Council Department of Education

Stake, RE and Easley, JA (Jr) (eds) (1978) Case Studies in Science Education I.R.C.E. & C.C.C., University of Illinois

Stead, B (1980) Energy Working Paper No 17, Learning in Science Project University of Waikato, Hamilton, New Zealand

Stead, K and Osborne, R (1980) Friction Working Paper 19, Learning in Science Project, University of Waikato, Hamilton, New Zealand

Stenhouse, L (1978) Case study and case records: towards a contemporary history of education British Educational Research Journal, Vol 4, No 2, 1978

Stenhouse, L (1979) The Study of Samples and the Study of Cases Presidential Address to British Educational Research Association, September 1979

Stenhouse, L (1982) The conduct, analysis and reporting of case study in educational research and evaluation, in McCormick, R (ed) (1982) Calling Education to Account, London: Heinemann in association with the Open University

Stenhouse, L (1985) A note on case study and educational practice in Burgess, RG (ed) Field Methods in the Study of Education, Lewes: The Falmer Press, p 263-271

Sutcliffe, J and Whitfield, RC (1979) Classroom-based teaching decisions in Eggleston, J (ed) Teacher-Decision Making in the Classroom: a collection of papers p 8-37

Symington, D, Osborne, R, Freyberg, P, and White, R (1982) A Perspective on Primary School Science Learning in Science Project (Primary) Working Paper No 104, S.E.R.U. University of Waikato, Hamilton, New Zealand

Tabachnik, BR and Zeichner, KM (1986) Teacher beliefs and classroom behaviour: some teacher responses to inconsistency, in Ben-Peretz, Bromme and Halkes (eds) Advances of Research in Teacher Thinking Lisse: ISATT, Swets and Zeitlinger, p84-96

Tasker, R, Freyberg, P and Osborne, R (1979) Focus on Process Skills Working Paper No 7 of L.I.S. Project University of Waikato, Hamilton, New Zealand

Tillema, H (1984) Categories in teacher planning, in Halkes and Olson (eds) Teacher Thinking, a New Perspective on Persisting Problems in Education Lisse: Swets and Zeitlinger, p176-185

UNESCO (1980) Handbook for Science Teachers Paris: UNESCO/
London: Heinemann

Verloop, N (1987) Investigating teacher cognitions. Report of the third ISATT Conference (held at Levven, Belgium, 14-17 October 1986) in ISATT Newsletter, 5, October 1987, p 23-31

Walker, R (1980) Making sense and losing meaning, in Simons, H (ed) Towards a Science of the Singular Norwich: CARE, p222-235

Walker, R (1983) Three Reasons for not Doing Case Studies in Curriculum Research Journal of Curriculum Studies, 15, No 2, April-June 1983, pp 155-165

Walker, R (1986) The conduct of educational case studies: ethics, theory and procedures, in Hammersley, M (ed) Controversies in Classroom Research, Milton Keynes: Open University Press

Watts, MD (1983) A study of school children's alternative frameworks of the concept of force European Journal of Science Education, 5, 2, pp 217-230

Williams, P and Jinks, D (1985) Design & Technology 5-12 Lewes: The Falmer Press

Wilson, SM, Shulman, LS and Richert, AE (1987) '150 Different 'ways' of knowing: Representations of knowledge on teaching, in Calderhead (ed) Exploring Teachers' Thinking: London, Cassell Educational, p104-124

Winne, PH and Marx, RW (1982) Students and teachers' views of thinking processes for classroom learning The Elementary School Journal, 82, (5), 493-519

Winter, R (1982) "Dilemma Analysis": a contribution to methodology for action research Cambridge J. of Ed., 12, 3, Michaelmas Term 1982

Wittrock, M (ed) (1986) Handbook of Research on Teaching
New York: MacMillan

Woods, P (1979) The Divided School London: Routledge, Kegan Paul

Woods, P (1986) Inside Schools. Ethnography in Educational Research
London: Routledge, Kegan Paul

Yin, RK (1984) Case Study Research. Design and Methods
Beverly Hills: Sage Publications

Yinger, RJ (1977) A Study of Teacher Planning: Description and a Model of Preactive Decision Making Research Series No 18 East Lansing, Michigan: Institute for Research on Teaching, Michigan State University

Yinger, RJ (1980) A study of teacher planning The Elementary School Journal, 80, p 107-27

Zeichner, KM, Tabachnik, BA and Densmore, K (1987) Individual, institutional and cultural influences on the development of teachers craft knowledge, in Calderhead, J (ed) Exploring Teachers' Thinking, London: Cassell Educational, p21-59

APPENDIX 1: CODING SYSTEM USED FOR LISTING AND REFERRING TO DATA

Headings

Data was organised under headings of:	Coded
Interviews and other Conversations	IC
Observations and Recordings of Lessons	OF
Documentation including Plans & Products	DP

Codes for data

- (a) Each piece of data was identified by date, eg 25/7/84, and form of record:

Fieldnote made on observations	FN
Audiorecord (plus number & side of tape)	AT (1A etc)
Videorecord (plus number of videotape)	VT (1 etc)
Written note by researcher, eg of conversation	WN
Teacher's written record, eg of lesson plan	TW
Pupil's work, collected or copied	PW

- (b) Details were located by note of time of observation or recording, page number of field note or transcript, counter number of audio or videotape, eg both 1/5/84 - FN 10.45 (p1) and 1/5/84 - AT 10.45 (p1) refer to the start of the 'Downhill' lesson on 1 May, recorded on fieldnotes and audiotape respectively.
- (c) Cross-referencing of data during analysis and initial checking across data sets used those codes in the margins of notes (see examples of summaries in appendix 2). Detailed coding was retained in drafting of thesis. In the final draft data cited is referred to either in words, eg "at the interview on 2 May" and "the teacher's written assessments of pupils on 2 May", or by a subscript which is a reduced version of the original full coding, eg 2/5/84 - AT13 and 2/5/84 - TW respectively identify the audiotaped interview and the teacher's written note.

APPENDIX 2A: LIST OF DATA HELD

Interviews and other Conversations (IC)

(a) Interviews with teacher

20/7/83-WN	initial discussion in school
12/10/83-AT1A	interview
29/11/83-WN	at meeting of teachers' group
8/3/84-WN	spontaneous comments by teacher
28/2/84-TW	note on transcript of 12/10/83-AT
20/3/84-AT9	interview/discussion of project plans
12/4/84-AT11A	interview
2/5/84-AT13	interview after lesson
11/5/84-WN	discussion before and after lesson
14/5/84-AT17A300	discussion before & after lesson
14/5/84-WN	confirmation of 14/5/84-AT17A
15/5/84-WN	discussion before lesson
18/5/84-WN	discussion before lesson
27/5/84-AT22	interview
3/6/84-WN	telephone conversation
7/6/84-WN	discussion after lesson
12/6/84-WN	discussion over lunch
15/6/84-WN	response to 12/6/84-WN
20/6/84-TW	further elaboration on 15/6/84-WN
27/6/84-WN	telephone conversation
13/7/84-WN	discussion after school
16/7/84-WN	telephone conversation
24/7/84-AT33	final interview

(b) with other adults

Advisers	
18/7/84-WN	meeting with science & primary advisers
Headteacher	
8/3/84-WN	discussion of protocol and project
20/7/84-WN	telephone conversation

(c) with pupils

Interviews with target pupils

1/5/84-AT12B
24/5/84-WN&AT20B
15/6/84-AT27A
21/6/84-FN
13/7/84-AT31
13/7/84-WN
19/7/84-WN

Observations and Recordings of Classroom Activities (OF)

8/3/84-FN	whole day in school, recording during lesson on mirrors; piloting my observations
8/3/84-WN	write up of observations, for teacher's comments
19/3/84-FN	another mirrors lesson; more piloting of observations and recording for a morning

10/4/84-FN lesson at end of spring term which
10/4/84-AT10 introduced Downhill activity
10/4/84-VT1

1/5/84-FN lesson on rolling loaded
1/5/84-AT12 toy cars downhill
1/5/84-VT 3 toy cars downhill
4/5/84-FN & WN these lessons making
8/5/84-FN & WN model vehicles
11/5/84-FN & WN to run downhill
4/5/84-AT14A " "
8/5/84-AT14B, 15, 16 " "
11/5/84-AT17 " "
11/5/84-VT4 " "
14/5/84-FN lesson making
14/5/84-AT17 bobbin tanks
18/5/84-FN lesson testing
18/5/84-AT19 bobbin tanks
18/5/84-VT4 Luke and Danny testing tank
24/5/84-FN lesson building
24/5/84-AT20 uphill vehicles
25/5/84-FN further lesson
25/5/84-AT21 building vehicles
7/6/84-FN last lesson
7/6/84-AT24 with uphill vehicles,
7/6/84-VT2 and final plenary
12/6/84-FN first lesson
12/6/84-AT25 making
12/6/84-VT5 mangonels
15/6/84-FN second mangonels
15/6/84-AT26, 27 lesson
21/6/84-FN 'siege'
21/6/84-AT29 lesson with
21/6/84-VT6 mangonels
2/7/84-FN last mangonels
2/7/84-AT30 lesson - work on
2/7/84-VT7 remote control
10/7/84-FN choices
13/7/84-FN lessons

Documentation, including Plans, Products and Publications (DP)

12/10/83-TW teacher's in-service document on cars
10/4/84-TW teacher's lesson plan for first lesson
nd -TW teacher's 'journal' entries of later lesson
plans and evaluations
2/5/84-PW pupils' written work
2/5/84-TW teachers' notes assessing pupils' work
15/5/84-PW pupils' work from jotters
18/5/84-PW pupils' writing up of work
20/6/84-PW copies of pupils' work
nd -PW pupils work in jotters and finished writing
from the term

additional documentation collected over the term

nd-slides	slides of pupils' work in progress and completed, classroom displays.
BBC 1982-VT	videotape and teachers' notes for Junior CDT Programme as viewed in topic
Feb 1983	teacher's list of school science stock
DES, 1983	teacher's annotated copy of HMI discussion paper, Science in Primary Schools

APPENDIX 2B: SAMPLE OF DATA RELATING TO ONE LESSON

For the lesson of 1 May the following data was collected

nd-TW	teacher's lesson plan and evaluation
1/5/84-FN	summary of field notes made during lesson
1/5/84-AT12	summary of transcribed audiorecord
1/5/84-VT3	notes made on videorecording
2/5/84-PW	copies of pupils written work arising from lesson of 1 May

2/5/84-AT13(p1-10) interview on 2 May (see Appendix 3)

2/5/84-TW	teacher's notes on his assessment of pupils' work in and from lesson of 1 May
4/5/84-WN	my notes of teacher's further
8/5/84-WN	comments on assessments

nd - TW: Teacher's lesson plan and evaluation, 1 May

1st May

Do cars go further if they are heavy?

Aims and Objectives

1. To build on previous experience of designing and carrying out experiments
2. Control of variables
3. Use of complex results to arrive at logical conclusion
4. To do above with minimum guidance
5. Accurate measurement
6. Calculation of median values

After

During the activity I circulated and gave advice on control of variables where necessary (about 50% I think) but tried to get ch to see this for themselves. Needed to be very directive to Jimmy and William. Generally pleased by class attitude and the way experiment carried out.

I didn't give enough time or thought to the last part of the lesson - reporting back - this was done hurriedly and tended to confuse rather than illuminate.

Writing up

No guidance apart from asking for clarity and good presentation of results

Objective

To give children time to study their data and come to conclusion and manipulate figures into early unstandard form

Comment

See check list attached (2/5/84-TW)

I would rarely if ever do this but wanted some quantifiable guide

- a) Pleased that vast majority have got results where variables are isolated
- b) Very pleased with tabulations of results which was almost universal
- c) Description of process almost always too sketchy but since we all did it why should we place undue emphasis on this?
- d) Little evidence of use of results to assist conclusion. There is no attempt in some and others haven't given it much thought. No simple graphs disappointingly and little attempt to group median results in separate table (I have done this on Luke and Danny's)

Rosie's account I'd single out as particularly succinct. She left out all but median's

Elaine's account e.g. of no effort to use results

Rebecca's account e.g. of attempt to make sense of confusing results but no attempt at explanation.

Luke and Danny	v.good practical Well recorded Needed guidance in extraction of medians to draw conclusion
----------------	--

Dorothy and Debbie	Uncertain about variables Poor recording Little attempt to make sense of results
--------------------	--

Elaine, Jenny & Rebecca	Eccentric practical. Didn't attempt to break out of 10g stepping when realised going nowhere. Patchy recording.
-------------------------	---

1/5/84-FN: Summary of field notes made during lesson

10.00 Maths. R id's & contacts all target pupils
Class - assembly
T & I set up for lesson; I record T's intentions for today ref VT3 notes

10.30 Break

10.45 'Science' lesson
T sets class a problem - target pupils as: ref VT3, AT13A

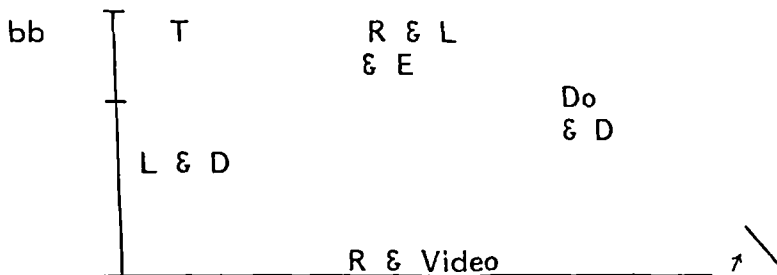

10.57 T "... Will a car that is heavier go further?" (referring to toy cars off ramp) Pupils volunteer a's including reference to "power" "weight" (I wonder who hears responses and takes in what - eg Do & D?) (could transcribe verbatim from VT3 & get eg's of pupils' responses) ref AT13A

VT3 (03.30) Do walks across picture on video record. Pupils' activities:

VT3 (07.30) T talks with headteacher

11.08 Do & D rolling weights (playing?) L & D measuring distances off ramp and weights
T to Do & D

T remarks to me how quickly most pupils have set at one height for ramp.
T to L & D, then R, J & E
Do & D tabulating and writing in 'cubes' - ie loads on car - in steps of
R & L & E recording
T working round other groups steadily (is he spending more time with them? I wonder as I film)

11.20 T consulted by R

11.25 I briefly discuss with Do & D to see what they are doing -they appear to be altering 2 variables

VT3 (30.50) T talks with L & D, then R, E & J, Do & D - he discusses their 2 variables ref 2/5/84-AT13A p 3 & 4

11.30 A interrupts L & D who go to VT3 (37.00) T who is still working with

W & J. Do & D report they
are "starting again", write out
table, then roll car
inconsistently.

AT12A change to B T reports that W & J's problem
was being unable to organise
selves - with his recording &
prompting they do it - now he
is away we see they are aimless
We then talk of overall progress ref 2/5/84-WN

11.45 T stops class - gets them
VT3 (48.00) together (filming stopped here
to save tape

AT12B 222 Plenary ref AT13B p9

1/5/84 - AT12: Lesson activities and interactions

Audiotape no: 12A date: 1/5/84
 Title/context of lesson: small groups investigating how weight affects distance vehicles roll off a ramp - task set by teacher

<u>Reference</u> counter number time Categories coded	<u>Content Summary</u>	<u>Comments & later</u> codings cross-references
10.45	room & class prepared for lesson	x ref 1/5/84-FN
10.57 000	T reminds class of question	x ref 1/5/84-VT3
ACT Tea set	to investigate & seeks pupils	x ref 2/5/84-AT13A
ACT Int cla	predictions and hypotheses	x ref 2/5/84-PW
ACT Pup com	2 boys, Steven & Mark, offer conflicting suggestions T accepts then sets group to investigate	x ref 2/5/84-WN for initial plan & assessment of PW link to end of lesson
020	raising questions of use of weights, recording results, and urging P's to think before starting. Then T directs groups to best working places in and out of classroom	T's later self-crit and his Tho. way int, tim & sel on plenary and The Sci know & The Lea
040		
ACT Tea man O50		
ACT Pup doi	Small group investigations. T moves round. Interactions with pupils' taped and transcribed.	x ref his plans & diagnoses 20/3/84-p8
ACT Int ind	T directs William & Jimmy closely here & later (vi390 12B to 125) Visiting target pupils (here & vi 330) gives differing time and degress of direction, eg re control of independent variables which some pupils are not attending to or finding confusing. This & questions of measurement and of interpreting results arise in contacts with non-target pupils at this stage too. Rebecca's group seek T's help over vehicle that 'turns', and issue of fairness/standardisation discussed	12/4/84-AT11A p3-6 & 10. 2/5/84-AT13A
ACT Int tea 10.0		
11.08 135		
155		
ACT Int pup 270	T visits other groups, revisits target pupils who are accumulating results, seeing some relationships (eg Luke & Danny here) & some exceptions (eg Rebecca et al) but in Dorothy & Debbie's case are unclear as they change 2 variables unsystematically T attempts to clarify by analogy the need to only alter 1 at a time and directs them to start again - they do & write a table T moves to far corner to	x ref VT3-23.30
ACT Int tea 330		
ACT pup thi 337 340		x ref VT3-30.50 1/5/84-FN p2 x 2/5/84-AT13A p 3,4,5
375		x ref 1/5/84FN p2 11.25 but see 1/5/84FNp2

390 sit with and work with W and J while able to view and be seen from rest of room. He goes through activity step by step with W and J; pausing to respond to Luke & Danny's report of Andy's interruptions x ref VT3-37.00

11.30 435
ACT Int pup 540

AT12B TAPE CHANGED TO 12B

ACT Tea dec
THE Chi ind

119 T tells observer how he organised, prompted & recorded for W & J, so they succeeded; in his absence they appear aimless. He comments on progress of others - eg Rebecca et al. W reports his progress to T.

ACT Int pup 125
11.45 140
ACT Tea man 150 T starts class tidying up Rebecca et al discuss odd results

220 pupils report back in class plenary. Mark and Steven comment on findings against initial predictions; both reverse original views more or less. Other pupils report own and seek to explain any relationships or exceptions and unexpected results with T directing discussion. for T's comments on 'plenary' technique see 20/3/84-AT9B & for his self-crit on this particular one see x ref 2/5/84-AT13A-9

ACT Tea set
ACT pup com
ACT pup thi
245

280 Target pupils involved slightly
290 Luke declining to draw conclusions until their extensive results have been inspected carefully. After some more pupils reports lesson closes with T noting when writing up and further analysis likely and when they can repeat tests if they wish x ref 2/5/84-AT13Ap3 20/3/84-AT9B for his view of 'plenaries' x ref on T's description of L - eg on his assistance to L & D in interpreting table - 2/5/84-AT13A

ACT Tea man

345 Lesson ends

Rest of tape has pupil interviews giving their account

356 L & D, Do & D, R

Summary

Lot of interactions with target pupils. - evidence of differentiated handling of this linked to his view of pupil differences with overall concern to build skills of planning and investigating. Incidental treatment of explanations and concepts and hurried class discussion associated with his self-crit of handling of plenary - more generally this and lesson can be related to his theories of how pupils learn what his goals and strategies are for this, and his immediate plans for

this lesson and pupils work assessed by him on 2/5/84. Pupils views and evidence of other data - VT3, FN, PW - make this a rich source for analysis and validation.

1/5/84-VT3: Notes made on videorecording of 1/5/84

Counter no.	Content	Comment
0	Opening talk - GP tells R of plans for pupils testing, expectations of their difficulties coping with open task and several variables, own intention to intervene only as needed & to individualise amount of direction; explains format of lesson and reason for self-contained lesson.	
39		
4	GP turns on t. recorder, sets task Mark and Steven's opposite hypothesis	x ref AT12 AT12.010
126	Pupils start work in pairs round room L & D work on carpet, eg measuring.	
c 144	GP visiting L & D, then R,	
c 200	and R again	
	Extended record of activities - tape run freely, some planning, mostly on target pupils. Useful for cross-checking other data, or recall, rather than direct use.	
	final plenary discussion and clearing up	

2/5/84 - PW: Sample of written work by pupils

(presented in the following order:)

Luke
Danny
Rebecca
Dorothy
Other pupils

Our Trolley Experiment

Height of ramp 3cm on a carpet

weight on trolley 10g

1st 20cm
2nd 20cm } median 20cm
3rd 20cm

Height of ramp 12cm

weight on trolley 10g

1st 60cm
2nd 62cm } median 62cm
3rd 64cm

Height of ramp 3cm

weight on trolley 50g

1st 26cm
2nd 25cm } median 25cm
3rd 25cm

Height of ramp 12cm

weight on trolley 50g

1st 65cm
2nd 70cm } median 70cm
3rd 70cm

Height of ramp 3cm
weight on lorry 100g

1st 26cm
2nd 26cm } median 26cm
3rd 26cm }

Height of ramp 12cm
weight on lorry 100g

1st 70cm
2nd 77cm } median 76cm
3rd 76cm }

Height of ramp 3cm
weight on lorry 200g

1st 28cm
2nd 28cm } median 28cm
3rd 27cm }

Height of ramp 12cm
weight on lorry 200g

1st 74cm
2nd 78 & 73cm } median 76cm
3rd 70cm }

height of ramp 3cm

Weight 100g

1st 26cm
2nd 26cm } Median 26cm
3rd 26cm }

height of ramp 12cm

Weight 100g

1st 70cm
2nd 77cm } Median 76cm
3rd 76cm }

height of ramp 3cm

1st 28cm } weight 200g
2nd 28cm } Median 28cm
3rd 27cm }

height of ramp 12cm

weight 200g

1st 74cm
2nd 78, 73cm } Median 73cm
3rd 70cm }

height of ramp 3cm

weight 300g

1st 27cm

2nd 29cm

3rd 28cm

} Median 28cm

height of ramp 12

weight 300g

1st 82cm

2nd 84cm

3rd 77cm

} Median 82cm

height of ramp 3cm

weight 400g

1st 31cm

2nd 31cm

3rd 33cm

} Median 31cm

We got a toy lorry and put different kinds of weights in and put the lorry on top of a slope to see if it would go further with weights in or not. I have found out that the first test which is 100g that the lorry only goes 1cm further.

Danny

Car Experiment

We wanted to find out if heavy cars go further than light cars. First we got 2 cubes, 6 weights a board and a ruler. We put a 10g weight into the car, and we put car down the ramp it looked like this.

When we had found out the results we carry on with this experiment until we had got up to 100g in the car our result turned out like this.

Weight	Layer of Cubes	How far
10g	1	23cm
20g	1	21cm
30g	1	20cm
40g	1	19cm
50g	1	21cm
60g	1	22cm
70g	1	19cm
80g	1	19cm
90g	1	18cm
100g	1	21cm

Rebecca

I heard that how many weights you
put into the car it will still go about the
same distance.

Rebecca

Light and Heavy.

We wanted to find out that if a car, tram, man with more weights or less weights. First we got a lorry, a few cubes, some weights and a board with a metre stick. We put four cubes under the board we put 3 10 gram weights in the lorry and let it go down the slope we made some measurements.

cubes	Distance	weights
4 cubes	1m 1cm	30g
4 "	1m 26cm	40g
" "	1m 51cm	50g
" "	1m 76cm	60g
" "	1m 101cm	70g
" "	1m 126cm	80g
" "	1m 151cm	90g
" "	1m 176cm	100g
" "	1m 201cm	110g

We found out that the heavy the the more weights the faster it goes.

Dorothy

We think the more weights
make it go quite the same.

We found out with a 30gram weight
it went ~~h~~ further than it did with
a 40gram weight.

Dorothy :

Light and Heavy

We got a car and some weights, cubes and a board. Because we wanted to find out that if you put a ten gram weight in the back of the lorry then we put one cube under the board and mr p. told us to start again. So we did but this times we put four cubes under it and we put upto 120gram weights in the back of the lorry. We found out wher with a

30g weight it went a lot faster ~~with~~ than it did with a 10g weight.

Cubes	Distance	Weights
1 cube	1m 14cm	30g
2	1m 24cm	40g
3	1m 31cm	50g
4	1m 41cm	60g
5	1m 49cm	70g
6	1m 43cm	80g
7	1m 52cm	90g
8	1m 47cm	100g
9	1m 28cm	120g

Debbie

Car Experiments

First we got a car, some weights, a board and some cubes. We also got a metre ruler.

We wanted to find if heavy cars went further than light cars

We set it up like this.

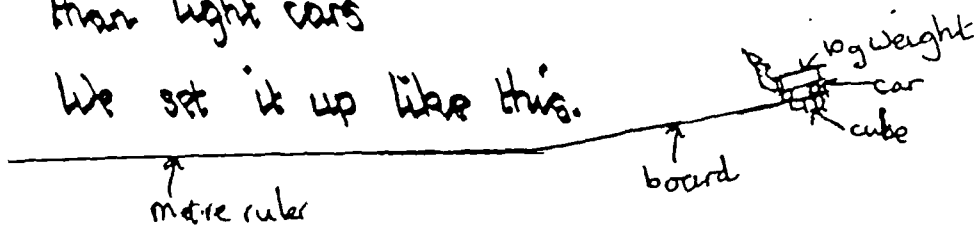

The metre ruler was put at the end of the board and when we let go of the car it rolled down the slope.

Weight	Cubes	How Far
10g	1	23cm
20g	1	21cm
30g	1	20cm
40g	1	19cm
50g	1	21cm
70g	1	22cm
80g	1	19cm
90g	1	19cm
100g	1	21cm

Do Heavy lorries roll further than light lorries?

First we got a lorry and some weights then we got a board and propped it up with cubes. Then we put a 10g weight in to the lorry. Then we put the lorry at the top of the ramp. The ramp is $3\frac{1}{2}$ m high and 45cm long.

Here are the results

$$\text{1st test } 10\text{g} = 1.26 \text{ m}$$

$$\text{2nd test } 10\text{g} = 1.26 \text{ m}$$

$$\text{3rd test } 10\text{g} = 1.15 \text{ m}$$

$$\text{median} = 1.26 \text{ m.}$$

$$\text{1st test } 20\text{g} = 1.17 \text{ m}$$

$$\text{2nd test } 20\text{g} = 1.28$$

$$\text{3rd test } 20\text{g} = 1.30$$

$$\text{median} = 1.28$$

$$\text{1st test } 30\text{g} = 1.31 \text{ m}$$

$$\text{2nd test } 30\text{g} = 1.31 \text{ m}$$

$$\text{3rd test } 30\text{g} = 1.25 \text{ m.}$$

$$\text{median} = 1.31 \text{ m.}$$

$$\text{1st test } 40\text{g} = 1.16 \text{ m}$$

$$\text{2nd test } 40\text{g} = 1.16 \text{ m}$$

$$\text{3rd test } 40\text{g} = 1.00 \text{ m}$$

$$\text{median} = 1.16 \text{ m}$$

$$\text{1st test } 50\text{g} = 1.27 \text{ m}$$

$$\text{2nd test } 50\text{g} = 1.26 \text{ m}$$

$$\text{3rd test } 50\text{g} = 1.20 \text{ m}$$

$$\text{median} = 1.26$$

$$\text{1st test } 100\text{g} = 1.30 \text{ m}$$

$$\text{2nd test } 100\text{g} = 1.30 \text{ m}$$

$$\text{3rd test } 100\text{g} = 1.34 \text{ m}$$

$$\text{median} = 1.30 \text{ m}$$

$$\text{1st test } 150\text{g} = 1.47 \text{ m}$$

$$\text{2nd test } 150\text{g} = 1.24 \text{ m}$$

$$\text{3rd test } 150\text{g} = 1.39 \text{ m}$$

$$\text{median} = .39$$

$$\text{1st test } 200\text{g} = 1.50 \text{ m}$$

$$\text{2nd test } 200\text{g} = 1.45 \text{ m}$$

$$\text{3rd test } 200\text{g} = 1.45 \text{ m.}$$

$$\text{median} = 1.45 \text{ m}$$

Weights in Lorries Experiment.

First we got a board and some weights and a lorry. and ~~set~~ Set a ramp up on the floor. The height of the ramp is $3\frac{1}{2}$ cm. The length of the ramp is 45 cm. And run the lorry down ~~of~~ for three Experiment each. here are the Results weight 10g.

The 1st best.

1st Im. 26 cm. medium 26

2nd Im. 26 cm.

3rd Im. 15 cm.

weight 20g.

The 2nd best.

1st Im. 17 cm medium 28 cm

2nd Im. 28 cm

3rd Im. 30 cm

weight 30g

The 3rd best

1st Im. 31 cm. medium 31

2nd Im. 31 cm.

3rd Im. 25 cm

to

The 4th best

1st Im. 16 cm. medium 16

2nd Im. 16 cm.

3rd Im. 10 cm

weight 60g

The 5th best

1st Im. 27 cm medium 26

2nd Im. 26 cm

3rd Im. 20 cm

weight 50g

The 6th best

1st Im. 30 cm medium 30

2nd Im. 30 cm

3rd Im. 34 cm

weight 100g

Vanessa

Ivor

Do Heavy Lorries Roll Further than light lorries?

*

Flats	1st test	2nd test	3rd test
50g 6 flats	107cm	109cm	100cm
100g 6 flats	120cm	119cm	132cm
200g 6 flats	123cm	110cm	108cm
300g 6 flats	102cm	93cm	101cm
500g 6 flats	153cm	162cm	157cm

First we got some weights then a car we made a ramp we put the weights in the car and let the car run down the ramp and saw how far it went with different weights. I found out that more weight made it go faster.

Do Heavy Lorries Roll further than light lorries?

What we did was we got a pick up truck a metre stick and some cubes and a board and we put a cube under the board and we put a 10g weight in to the truck and we let the truck go down the ramp and our Results were. Then after

	cubes	weight	
1st test		10g	that we put a 50g weight on the lorry and our
2nd test		10g	
3rd test		10g	
Results			

	cubes	weight	
1st test		50g	I thought it would go about
2nd test		50g	
3rd test		50g	

60cm we were shur that the Results on the next test the results were going to heigher then on the last test we put a 1kg on the lorry and it would

(Dominic)

not move it would not go because all the weight was on the back wheels and the front wheels were not on the ground and the results when we did it were 11cm 8cm and 5cm then we did it with no gram and the results were

	rubers	weight	
1st test		0g	70
2nd test		0g	88
3rd test		0g	88
Medians			
2nd			cm

138 cm

3rd
138 cm

4th
70 cm

Car Experiment.

We wanted to find out if an heavy car would go faster further down a slope with weights on the back than a car with no weights on it. So we got one of Mr P. 's son's cars. It was a red and body and black wheel it was a toy car. We got it 1 four one gram weight. [6] One fifty gram weight and one hundred gram weight.

Height	Length	How far	
3cm	50cm	10g	We found out that up to 100g the car did not go as further as over 100g.
"	44 "	20g	
"	43 "	50g	
"	42 "	60g	
"	41 "	70g	
"	25 "	100g	
"	42 "	110g	
"	45 "	120g	
"	55 "	150g	
"	40 "	160g	
"	42 "	170g	
"	40 "	180g	

Steven

Cars and Weights

	Weight	height of load	It travelled
Median	20g	6cm	1m 35cm
Median	50g	6cm	1m 43cm
Median	70g	6cm	1m 40cm
Median	100g	6cm	1m 43cm
Median	120g	6cm	1m 47cm
Median	150g	6cm	1m 40cm
Median	170g	6cm	1m 47cm
Median	200g	6cm	1m 64cm

We had a car and a 6cm high slanting board. We put weights on the car to see how far it would go. The results are above. I found out that the more weight on the car the farther it will travel. That's because it gives it more power. The weight pushes the car down the slope.

Rosie

Do Heavy Lorries roll further than light Lorries?

We Yesterday we wanted to find out which went the furthest the heavy lorries or the light lorries so we got a board and put *it* up against the pipe and got some weights and a lorry and put 100 grams in the back of the lorry and put at the top of the ramp and let it go and it went 2 meters 60 cm and the furthest it went with 200 grams was 2 meters and 61 cm and with ^{three} hundred grams it went 2m 74 cm and the best it went was 3m 30 cm with 600 grams and after Mr P. asked us questions and I found that the more weight the further it goes the lighter weight the smaller it goes.

100g } 2m 60cm
 2m 60cm
 2m 60cm

400g } 2m 98cm
 2m 97cm
 3m 6cm

200g } 2m 61cm
 2m 30cm
 2m 37cm

500g } 3m 23cm
 3m 18cm
 3m 21cm

300g } 2m 74cm
 2m 58cm

2/5/84-TW: Teachers' notes on his assessment of pupils

This is GP's assessment of pupils' achievements in lesson 1/5/84 & follow up 2/5/84 based on their written results for columns 2 & 3 and on his observation at time for 1. 4 refers to whether he infers from the writing (& recall of session?) whether they had mastered control of other variables by the end of the lesson.

Teacher's Key a - very good, b - good, c - poor

- 1 - skill and approach to practical
- 2 - recording activity and table
- 3 - using results to assist conclusion (whatever the conclusion, ie is it consistent with results)
- 4 - control of variables by end of lesson

Assessment of writing
Weight of cars alters distance

<u>Class 6</u>	<u>1</u>	<u>2</u>	<u>3</u>	<u>4</u>
Bennett	a	a	c	a
Hill	b	a	a	c
Barnett	b	a	c	a
T> <u>Danny Taylor</u>	a	a	a	a
Thompson	a	a	a	a
Toyne	a	a	a	a
Nicklin	b	c	c	a
Steven Jones	b	b	c	a
Horton	b	c	c	a
Robinson	a	a	a	a
Horton	c	c	c	b
> Mark Cutts	a	a	c	a
T> <u>Luke Marston</u>	a	a	a	a
T> <u>Rebecca Stevenson</u>	b	a	a	a
Fletcher	a	a	a	a
T> Wilson	b	a	a	a
Pickersgill	b	b	a	b
T> <u>Dorothy Jolley</u>	b	a	c	a
Cole	b	b	c	b
Roebuck	a	a	a	a
Sutton	a	a	a	a
Straw				
T> Needham	b	a	c	a
Grainger	a	a	a	a
T> Cockram	b	a	c	a
Fisher	b	b	c	b

T> indicates a pupil in the original sample; _____ one of the target group

> indicates another of interest because GP had commented on them, or in the lesson and/or their writing some evidence relating to his intentions is to be found.

4/5/84-WN: my notes of teacher's further comments

I asked GP how he marked pupils work of 2/5/84. He explained that he inferred category 1 from his observations in the lesson, category 4 from whether their results showed they had got the variables under control by the end of the lesson; 2 and 3 from their written work. He asked if I agreed or had other queries - I avoided further comment.

8/5/84-WN: my notes of teacher's further comments

GP elaborated on his assessment and influences re category 3 (interpreting results) in the light of

a) seeing all the work he noted their tendency of many pupils to form some conclusion not really derived from evidence - but identified some exceptions*

b) having tried the activity himself at home and found how increasing the weight can reduce the distance travelled by some toy cars, he now supports Mark's initial hypothesis.

* eg Rebecca he cited as being rightly cautious over her results, Luke and Danny as being careful over measurement and drawing of conclusions.

APPENDIX 3A: SUMMARY OF INTERVIEWS AND CONVERSATIONS

The data are transcripts of 6 major interviews (*) plus numerous conversations written down or recorded and some notes or these from teacher.

The earlier conversations focus on methodological matters such as the negotiation of a framework for the study, and on contextual information such as the class and the teacher's goals and organisation for their year together. His theories and planning are explored as they emerge over the first two terms. The interviews involved are:

- 20/7/83-WN initial discussions in school at the end of the previous school year.
- *12/10/83-AT1A one of the major interviews, in the first term of that school year; summary below.
- 29/11/83-WN discussions during teachers' group meeting.
- 8/3/84-WN spontaneous comments by the teacher during my visit to practice observation.
- 28/2/84-TW teachers brief notes on 12.10.83 transcript and development of his plans and the class. His thoughts about the year's goals and plans are explicit; clues to his theories about teaching primary science might be inferred.
- *20/3/84-AT9 second major interview which contains large sections referring to teachers thoughts on goals, strategies and plans, some reference to situational influences; I noted many methodological points, eg selection of target pupils, and quotable metaphors in the teacher's language. See summary that follows.
- *12/4/84-AT11 A third major interview; last before term's project underway; refers to plans. See summary.

The later conversations and interviews occurred during the term of the project. Several therefore arose before, during, or after lessons, or are notes and conversations incidental to or commentary on the more deliberate interviewing. Three major, planned interviews were done, one early on, one at half term and one at the end of the term.* Their format and concerns reflect the developing action and research. Potential, and need for, cross-referencing internally and with other data accumulating.

- * 2.5.84-AT13A Interview early in term arising from a lesson, further stimulated by video replay
- 11.5.84-WN Teacher's comments before and after lesson
- 14.5.84-AT17A Teacher talking before lesson
- 14.5.84-WN Teacher discussing plans while pre-viewing on TV
- 15.5.84-WN Teacher talking of plans for 18.5.84
- 18.5.84-WN Brief comments from teacher
- * 27.5.84-AT22 Half term interview
- 3.6.84-WN Brief telephone call
- 7.6.84-WN Teacher's comments in and after lesson
- 12.6.84-WN Teacher's comments on his theories
- 15.6.84-TW and his written clarification
- 20.6.84-TW Teacher's explanations to class reported
- 27.6.84-WN Telephone report on progress and plans
- 13.7.84-WN Teacher's spontaneous remarks after school
- 16.7.84-WN Teacher's telephoned comments on pupil interviews
- * 24.7.84-AT33 Final interview; includes structured report of his background and his evaluation of term

APPENDIX 3B: NOTES ON EACH INTERVIEW AND CONVERSATION

20/7/83-WN - Initial discussions

Agreement over access and possible framework easily reached.
Technical constraints and need for naturalistic approach discussed.

12/10/83-AT1A - Interview - the first

Content

Stance, procedures, plans negotiated. Background of year's plans, class as seen at this time and previous teaching. T's thoughts on summer term fore-shadowed. T's theories probed and introspected; evidence of his views on science knowledge, learning, planning and of dilemmas over direction/discovery, and his own awareness of tendency to intervene. Structure of his knowledge surfaced in his own image of 'repertoire' of activities. T's confidence, autonomy and situational influences round, including LEA and class.

Major categories coded are SIT, THE and THO. MET memos could be added throughout.

Reflections

Broad analytical framework OK but needed collapsing and unit of analysis uncertain. Much here - some quotable - to link to later data and to literature ideas - eg establishing 'frame' early in year, 'nesting' of plans, 'activities' as key unit in plans, issues and images - eg 'repertoire', - abound.

29/11/83-WN - discussion in teachers group meeting

Relationships and links with teachers' group explored. Potential for action-research by GP established.

28/2/84-TW - teacher's written notes

T's thoughts about goals for project explicitly stated; some underlying theories might be inferred. Essentially this note confirms 12.10.83-AT1A and qualifies statements there, referring also to observations on 12.10.83. It raises analytical problems of reduction and interpretation.

8/3/84-WN - Teacher's comments

May be useful confirmation/qualification of other statements
- ref 12.10.83-AT1A and 8.3.84-FN.

20/3/84-AT9 - Interview

Content

The early sections of this interview recapped and probed the teacher's concerns for this class and the strategies he would try to achieve, his broad goals such as increasing their initiative by reducing the emphasis on their recording and providing more time. Discussion of his interventions gave incidental confirmation of his customary patterns of working, eg setting and monitoring tasks, varying the form of recording and of some constraints such as the expectations of others and of some opportunities such as this classes writing skills. He reflected on the appropriateness of their work in the first two terms and what they have learnt as a spring-board for new directions; providing metaphors that are valuable for quotation (see pp 4/5) and serve as a vivid heading for the start of the project to be studied, ie 'off the motorway and onto the byways.'" The framework for his goals and the stance, roles and relationship in the research were confirmed. Potential target pupils were identified. Main categories coded are THOUGHTS and METHODOLOGICAL notes.

Reflections

In general this interview pulled together the discussions and observations in the planning stages of the study - eg the teacher's goals, plans and activities along with my own clarification re what, whom and how to collect data. Methodological queries were explored with the teacher too. Some early probing of his hypotheses and thinking/practice occurred; interestingly my later view that more integrated picture rather than discrete units of thinking → practice → evaluation would prove appropriate is here foreshadowed (eg see p 3, pp 5/6) but I was not myself clear at that stage about whether there should be separate analysis leading to a synthesis.

12/4/84-AT11A - Interview

Content

The start and finish of this interview firmed up methodological decisions, eg techniques for data collection, what the teacher hoped to gain in the study, and saw as the hypotheses for his action-research, feedback that could be provided, and the effects of an outsider. In particular selection of target pupils was agreed in a discussion which also revealed the teacher's views about pupil differences in ability, style and skills.

Major categories coded were METHODOLOGY, especially re selection of pupils for study, and also on negotiation of agreed procedures; THEORIES relating to children's individual differences; THOUGHTS referring to plans and selection of activities also occur.

Reflections

Theories about children, teaching and science are interwoven in places, overlapping with plans, goals, and strategies which are themselves inter-related. See eg pp 9-13 for instances of teacher's plans and selection of activities in the context of particular opportunities in the summer term against the background of his views on children and teaching science. This perhaps illustrates the need for a holistic account but also an analytical approach to this - and the difficulties of doing such analysis on unstructured interview transcripts.

2/5/84-AT13A - Interview

Content

Opening spontaneous talk by T on his evaluation of lesson of 1.5.84 (eg on target pupils' progress, understanding and application of ideas, his interactions) further stimulated by replay of video record. Particulars, eg R & J's measuring faults, lead to general reflection by T; eg (1) on when to teach skill and direct pupils and the dilemma of skill instruction versus independent inquiry, eg (2) pupils' ideas and his handling of these in plenary critically analysed by T. Time emerges as a constraint and another of his variables for his A-R, pupils' recording, is pursued. Hereafter T spontaneously reflects on and rehearses his plans, taking account of constraints, juggling possible activities and approaches, considering his earlier teaching and pupils' progress, and anticipating their response to tasks. Short and long term plans included and it includes aside on his theories about primary science, a reference to resources, and an explicit statement on his planning style.

Major categories coded are THOUGHTS and plans, relating to ACTIONS and inter-actions, with reflections on children. Methodological marginalia throughout.

Reflections

Methodologically, the potential of multiple methods, the value of stimulated recall, and the status of spontaneous comment arise. Concepts and themes emerge (eg teachers planning 'scripts' for lessons rehearsed; 'nesting' of levels of plan); issues and dilemmas (eg on skill teaching, direction v. discovery, constraints of time. Also problems of reduction, unit of analysis, and potential of coding combined with interpretation evident. Thinking/action relationships here and in relevant field notes, x-refs, full of promise.

11/5/84-WN - Teacher's comments before and after a lesson

Content

T's comments relate to forward plans against background of present progress. First of his deliberations over use of TV programme (Junior Craft and Design) reveal larger question of how processes should be taught and the dilemma of the claims of a discipline and direct teaching (Technology process here) versus psychological and ideological claims (of pupil interest and need). This can be pursued into the later decisions commented on 14.5.84, and the action and evaluations in field notes and tapes of interactions.

Categories coded - THEORIES of Learning and Teaching, linked with THOUGHTS on Activities and Plans.

Reflections

Theme/issue/dilemma of process and skill instruction v. pupil-centred inquiry.

14/5/84-WN - Teacher's discussion of plans while reviewing TV

Content

Further deliberation on use of TV following 11.5.84-WN extends those reflections on approaches to skills teaching, firming up immediate choices into a lesson plan as well as making explicit statement on his position over skills.

Categories coded - THEORIES re teaching related to THOUGHTS

Reflections

Useful short eg (but not verbatim) of plans in general - a particular lesson plan and therefore could be used to illustrate/support concept of 'planning script'. Dilemma/issue of skill /process teaching linked with previous note and subsequent transcript these are nicely developed.

14/5/84-AT17 - Teacher talking before lesson

Content

This talk linked to T's reviewing TV programme for use fills out and extends my earlier/concurrent written notes. He details his decisions on coming lesson in a way that illustrates emerging, modified lesson 'script'. Bigger, general questions (eg on skill instruction) and context (eg longer term goals and other activities in topic) and his beliefs underpin this planning but more specific, particular decisions illustrated as lesson approaches - eg which activities to use, when and how in lesson. At end he gives a spontaneous report and evaluation of a decision in a lesson.

Categories coded largely concern THOUGHTS and Plans linked to Goals, Activities, with passing reference to SIT, THE and ACT. METHODOLOGICAL notes made include quotable bits and potential/eg of confirmations.

Reflections

3 pages contains verbatim and my summary of considerable potential within the study for pursuing links and themes - especially the planning process as it develops, is 'nested' and teasing out levels and relationships to earlier and later data and its resolution in a particular case illustrated with the lesson (xref also to 7.6.84- to see how this can be reconsidered with new experience)

15/5/84-WN -Teacher talks of plans for 18/5/84

Content Teacher volunteered current planning thoughts on a lesson - its elements, goals, shape and his preparation for and setting of the talk. He also noted differences in his planning at other times for other ends - eg more pre-specified - and contrasts with his present middle course to suit goals.

Categories coded are all THOUGHTS.

Reflections Though not verbatim this short note could be a concise source of how ingredients in thinking combine in a lesson plan with a particular purpose; plus explicit T statement of contrast with other plans for other ends and circumstances which he raises also at start of 27/5/84-A722. Also x ref to 18/5/84 -FN

18/5/84 - WN - Brief talk before lesson

Content in which his career progress is noted and his disquiet re specialisation pressures from HMI is prompted by press report.

Categories coded SIT Car and THE Tea

Useful for context making, ie T's career concerns throughout term and his ideology and theories in wider social and political climate.

27/5/84-AT22 - Interview at half term

Content A rich transcript of an interview which looks back and forward. It contains long explicit statements of T's evaluation, reflections, and theories of teaching, learning and primary science. Some dilemmas are clarified in T's own words - eg on discovery v direction under the constraints of time and to a lesser extent the expectations of others. Lessons and the progress of pupils are evaluated with reference to goals and strategies and related to his more general thinking.

Categories coded include lots on THOUGHTS and ACTIONS: THEORIES are represented and SITUATION briefly noted. METHODOLOGICAL references are largely possibilities for writing.

Reflections Full of potential for analysis/use. Main problem is how to reduce it. Lots could be drawn on to quote, analyse, and integrate thinking and practice. Issues and dilemmas, direction/discovery, time individual differences, learning of primary science contrasted with secondary subject knowledge, building of experiences for later consolidation, the role of the primary teacher. Car x ref widely to his views, and to action, 25/5/84-FN

7/6/84 - WN - Teachers comments at playtime and after lesson

Content Spontaneously, and later aided by replay of his talk to class, T's judgements of pupil progress and his teaching to link with the action in the lesson. Here condensed they include thoughts on earlier views and longer term plans, pacing and varying and shuffling activities. He reflects on his decisions and dilemmas over intervention. The lesson represented a turning point where a more directive approach was decided on for a short episode.

Categories coded are ACTIONS and THOUGHTS.

Reflections Lots of potential for x referencing, quoting - eg on how he decides to pursue a tangent or not. A dense page of data which can be used in several ways, illustrates possibilities of multiple coding or alternative/ supplementary analysis, dilemmas/themes and planning/ thinking here particularised but potentially generalise-able and can link into literature and other data in this case as well as illuminating a descriptive account of the developments of the projects.

12/6/84-WN &

15/6/84-TW - Teachers comments and clarifications

Content Arising from a lunchtime discussion T's theories of primary practice and science learning/teaching are refined in later comments to provide verbatim and qualified picture of what, why and how scientific and technological concepts and skills should be taught.

Categories coded THEORIES.

Reflections Methodologically illustrates validation process and offers potential items for writing. Bits might be used to illustrate integrated nature of thinking - eg refined, intertwined theories - or alternatively to repeatedly re-analyse for strands in analysis. The parts and whole illustrate the T's framework of ideas that underpin his view of primary science and his particular action /thinking in this project

20/6/84-TW - T's elaboration on comments

Content in lesson of 15/6/84 when he explored concepts underlying trajectory with pupils. This could x ref to the above as a particular instance and to the pupils actions and products.

X ref - 15/6/84 - FN

27/6/84 - WN - Telephone call by T

Content T reported progress and plans

Categories coded THOUGHTS; briefly ACT Pup and SIT Con

Reflections Short note, not verbatim, but shows combination of immediate plans, rest of topic and anticipation of end, against long term goals and strategies. It might usefully link with earlier and later plans and actions.

13/7/84 - WN - T spontaneous comments

Content On route home T's incidental talk gives insights into situational issues, differences between teachers; his own background and where he shares and departs from LEA ideology and how present project relates to this.

Categories coded THOUGHTS and THEORIES, especially SITUATION.

Reflections This short note does in some ways integrate some separate strands from early in the research and could be used with x reference to them and to later discussion with LEA advisers. (18/7/84 - WN)

16/7/84-WN - Telephone call from T

Content	T gives feedback on my interviews of pupils (x ref
X-Ref	- 13/6/84 - AT 31)
Reflection	This illustrates validation in progress

24/7/84 - AT33 - Final Interview

Content	The teacher's final evaluations are systematically explored in this more structured interview and background information on the teacher is confirmed and expanded. An overview of the project is provided and its shape and interruptions - constraints revealed. Methodological checks are included - eg on reflexivity.
---------	---

Major Categories Coded are THOUGHTS and ACTIONS with many METHODOLOGICAL marginalia .

Reflections	Important source of information concisely and accessibly summarised, and of post-active thought to integrate into the description, analysis and model. T's words/ views might be quotable. Less use for probing T's thinking processes than earlier interviews as this was not the purpose or time. Served its ends and could be cross-referenced to much of previous data.
-------------	---

APPENDIX 3C: TRANSCRIPTS OF TWO INTERVIEWS

2/5/84-AT 13A: Interview at start of Summer term

((initial comments from written notes made before tape recording started. T started without prompting into comments on the childrens' writing up of the morning following the previous days lesson 1.5.84 -VT3 & 1.5.84 -AT12 - T remarked on high success rate in terms of his interpretation of many pupils' both understanding what they were doing as well as getting results and also some pattern out of it; he intends to look at their work more thoroughly and try to quantify somehow how many pupils appeared to understand even if their measurements precluded a very clear pattern of results and how many got good results and understood and thirdly those who seemed to be fairly aimless or did not grasp it - he felt the last to have been a small number and he was pleasantly surprised how well children had grappled with a somewhat open and difficult task. He also talked then about the discussion he had with them to try and see what explanations they used and how they understood the process - in this case of a car running down a ramp - and to some extent whether they could separate variables. He asked them if they knew where the energy had come from, when the car was rushing down the slope and had the impression that most of the children understood that the energy was from it being lifted and that it would be greater for a bigger weight or heavier vehicle - he said he formed his impression largely by the looks, answers, questions and responses when he was asking about it - when he lifted and dropped vertically weights he used to compare and discuss the children nearly all said they would drop at the same rate and made explicit reference to some work they did in the second year on flight. (They were less clear when asked about what would happen on the moon when eg. a feather and a weight were dropped, expecting the lighter to drop first and several appeared to refer to air resistance as a tentative explanation). He felt the pupils could apply these ideas more effectively and appropriately than he would have expected and relate them to their explanations of different distances the vehicles went when rolled down ramps in discussion but when writing up later at least half said the heavier one went faster and had not made the connection and he felt they might be able to generalise so far but no further from previous work and the understandings they had broke down after a little while. This did not surprise him and he was still impressed with their grasp))

((T talks about the lesson and his interventions or non-interventions and reflects on this with reference to two girls and the evidence of their work and of the audiorecord of his contacts with them; their later comments to R, :-))

T (Rebecca and Jenny).. they were the ones who'd done their 10,20,30,40,50,60,70,80,90,100 grams and they'd done it very thoroughly (thirty of them) to no effect!

R yeh

T and again the they'd () done the medians and set it all out and they still . you know . at the end I said "Well there isn't a pattern here is there?"

R yeh

2/5/83-AT 13A 2

R yeh

T and they were fairly happy about that - and they're two very clever girls (you) probably don't realise

R () they talked about that at the end of the lesson ((R refers to taping of that of T's interactions in lesson))

T I think really looking back I should probably have said to them "I would do something (else) as well" I think I ought to have done that to make it more worthwhile

R yeh ... mm .. well it will be interesting when you actually listen to the tape to remind yourself what you actually said to them

T I think I said to them "that's a lot of work"

R that's one of your quotes .. yes .. certainly .. and things like .. they were rolling the vehicle both ways

T that's right

R at one stage and you said (to them) "Does it matter? And now you've started that way you've got to stick with it." That's not a very good vehicle it seems is it?" and things like that .. which were coming through

T yeh

R and they were talking about .. they got onto a different problem almost about why that one didn't work

T yeh almost it would have been more worthwhile for them to have pursued that idea maybe .. although I think its .. difficult when you've set yourself an .. idea and thinking about .. probably very difficult in terms of a lesson like that .. if you're just going to do a lesson . to start letting too many things go off because you can't .. () can't follow up too many lines of reasoning .. () I tend to want to in a lesson like that .. to just go and do this task

R its a matter of how many places you can be in at once isn't it?

T yes

R you can't sort of do

T and then to contrast what we were saying about Jenny and Rebecca .. with Luke and Danny .. looking at their results .. its quite impressive the fact that they and all those .. alterations of height .. did them again for all the different heights and then suddenly realised it was obvious when they look at it they ought to do just one height and then changed it back

R did they?

100T and they got about five or six readings for ()

2/5/83- AT 13A 3

- R that's what they've done today?
- T they've just copied that up .. that's what they had done
- R Oh they've just taken those out of their existing measurements?
- T yes
- R yes .. of course again they were saying at the end and they said to me as well at interview "Well we don't know what we've got really yet till we've looked at them .. no we don't want to make .. any sort of jump to a judgement"
- T mmm ... yes .. what they found a little difficult there .. I had to just push them into .. they set out all their results and they were saying .. very guarded about the (affair) because it didn't look very convincing
- R yeh
- T so it was only when I said "You must now get all of your 3 centimetre readings and put them together .. they hadn't put them together .. they'd left them scattered around ..
- R which
- T and there were quite clear progressions .. the gradual .. it wasn't big .. but it was absolutely a pattern .. the differences with 100 grams, 200 grams 500 grams, quite clear what the pattern
- R mm
- T but they hadn't pulled out all the measurements and stuck them down on their paper. and said "yeh that is it it increases by 5 centimetres () medium readings." They're very tentative
- R mm .. yes .. mm
- T Luke is like that anyway .. he'll go so far and then he seems to sort of get a log jam in the brain and (ones)
- R you mentioned that early on yes
- T its his .. erhm .. background, his home background ((refers to family break up)) his emotional background rather than intellectual confidence
- 125R mm .. now .. now it was interesting also .. you've also seen them .. at work a lot ((refers to video record and interview with pupils sometimes confirming but at others conflicting with impression that Luke always leads and Danny follows, which is how their relationship was characterised by teacher and the pupils))

2/5/83-AT 13A

4

135R what about the other two girls .. Dorothy and Debbie what did they get out of it?

T not much I don't think they seemed not .. to achieve .. much I'll have to look in more detail .. its been a rushed day today

R of course they started again anyway after you entered and rescued them from two variables didn't you?

T yes

R and whether they got any results at the time I don't know or whether they really know what they were doing .. is a question

T I think that's why three groups is such a .. variation

R mm .. yeh .. and they are

T its becoming clearer that Jenny and Rebecca unless they can () see where they are are in chaos

R yeh

T and they will do a set each superbly well .. they won't improvise .. so far I don't know what will happen (later)

((Break here, then comments on lesson of 1/5/84 stimulated by replay of videorecord . 1/5/84 - VT3))

175T its a lot more real than .. erh .. a lot of tapes I've seen of .. kids working . than that's .. it strikes me that a lot of them they're all sort of prim and proper

R yeh

T (when they're) chucking weights about and charging about () thats more real and the kids are actually working

R those two in particular seem to be almost oblivious of the camera

T yeh

R just occasionally Danny's eye caught it .. but otherwise they just got on

((Refers to limited awareness of camera, largely by pupils not in target groups))

would the way that those two kids are working be more or less what you'd expect of them?

T oh yes . yeh

((more of videorecord played to T))

250R if you've got any impressions really about how they're working or .. that it makes you remember that you hadn't otherwise it would be interesting from that point of view

2/5/83-AT 13A 5

T No I think .. it just reinforces what I thought anyway

R yes

T but it .. seems like that .. its remarkable just what sort of hassles they put up with .. and they do it remarkably well I mean someone's treading all over their work/

R yeh

T /and Andy flips in ()

R yeh

265T its remarkable just how well they're doing it ((comments on how well children in schools cope with appalling conditions of eg. lack of space and equipment))

.. its just their innate adaptability .. they just seem to cope with it as a fact of life

((further rapid viewing of sections of videorecord and discussion of how this could be used in future sessions))

325 ((discussion of interventions with William and Jimmy long time given to this, limited evidence of effect in their later writing up or contemporary answers, but not felt to be a waste of time because of social value, T's need for pause, and perception that others did not need him at that time, and strategic position where other pupils could and did go to him :-))

R you thought they were gaining from it at the time?

T yes .. I think they did .. I think they they must have gained from it actually

R your comments on that say that they did .. when you were there you they got lots done

T they did actually .. I mean .. that .. they that was the only time they really got anything done .. we did have a nice chat about the wheels rubbing on their and Jimmy in fact solved the problem by taking two of the back tyres off

R yeh

T to make it run

R oh yes .. thats on the tape

345T I was quite pleased with that

R yes .. and there's a little bit just after it see where .. erhm William comes up to you .. oh about a minute after you'd left them .. with some results .. he'd done the next one/

T that's right

2/5/83-AT 13A 6

R / on his own .. I don't know if he managed the one after that but he did that one certainly

T yes .. and they couldn't manage any more than that .. but I think I was .. yeh .. I think really it was so they could achieve something for once and now I could sit down and have a chat with them for a bit . and so they would want to do something similar again

R course one of the things you said prior to this was that .. you know you wondered if you spent enough time with some kids like that

T yeh .. yeh

R I don't know whether you were deliberately doing so .. or

T () certainly in the .. middle of my mind .. I (planned) to do more with someone like him

R yeh .. this here now is Dorothy ((refers to video record of T interviewing))

T I don't think that was very fruitful ()

360R well this is the one where you talked about the variables and about the shower

T oh yes .. that's right

R and that's on the tape

((T and R view video of this contact with Dorothy and Debbie, he comments on his impressions of their response to his suggestions that they start again, and on their work in general:-))

T No .. I can't remember they seem nonplussed .. they seemed as "Well life's like that sometimes."

R (laughs) yes .. that sums it up yeh .. it would be interesting to see what they .. their results indicate as well

400T their results they weren't .. weren't impressive their really .. results

430 ((further viewing of videorecord with reference to audiotape included more time spent with William and Jimmy. T's comments on how he distributed his time; Rebecca seen making crooked measurements which surprises T and R))

T but its obvious. in fact from looking at that .. that in a way whilst I'm saying that I wanted them to do it .. erhm .. their own way .. its clear from that actually that it would have been .. useful .. for me to have gone .. I hadn't mentioned how to measure

R mm (but) they'd done that last time

T yes

R is that something you've taught them before .. or?

2/5/83-AT 13A 7

T no .. not at all

R or talked about before?

450T so maybe you see they've been doing that all along .. and that we haven't actually seen them before

R think .. it might show up in their . results or?

T well .. it won't do because their results they're confused .. you can't tell whether they're confused because they're measuring crooked or because they're simply ..

R and you'd not noticed anybody measuring crooked .. as you went round?

T no .. I hadn't

R that's only .. one child we've seen doing it isn't it?

T but it mat

R there was another I noticed

T I saw a lot of them actually .. thinking about it .. just sort of going .. "Its about - (T mimes pupils' loose approximation) and not actually using a thing at right angles

R and actually the thing that you were doing .. to get any sort of result .. unless they're using very big weight differences - they'd need to measure fairly carefully?

T very

R as Luke and Danny

T were doing

R mm .. that shows up on the tape as well doesn't it .. their precision of measurement?

465T yes .. thats something which I hadn't .. hadn't mentioned .. and I'd obviously just left to chance

((some discussion of related evidence of video of an earlier lesson (10/4/84-VT2) T spontaneously returns to measurement and his note:-))

490T yes .. thats a clear thing .. that's been very useful to see the position of measurement shouldn't be left to chance .. Its in fact one of the basic skills and .. that maybe I should have taught

R yes .. and you've not taught before .. somewhere else?

T no

R and you assumed that they would do? yeh

2/5/83-AT 13A 8

495T I've assumed that they would do that

((further discussion of whether pupils did start rolling cars from same point at the start of ramp, as well as issue above concerning measuring of end point of vehicles run))

522T see .. then you .. its a bit of a dilemma to know whether you should teach specific skills .. I think probably you should .. I should

R mmm

T but .. one time .. yeh I think that its a skill like hand-writing you ought to teach something that they ... can't be expected to just pick up

R it depends on how you approach them doesn't it ...

((raises alternative approaches notes APU test))

590 ((discussion of limited incidental teaching opportunities on Friction; instance of T telling 2 pupils to not worry about effect of working on carpet as it would affect all results equally and pupils accepting this - neither T or R could infer whether this was because they fully understood or did it because of T's authority; he said it to keep the lesson moving:-))

605T I think clearly then they were asking me that and it was (roughly) the start of the lesson and I just said - wanted to get them going/

R yeh

T / in that place and basically said "Do it there" I think it was just a natural

((reference to some talking by pupils that they recorded themselves for T:-))

R they talk about all sorts of reasons why the thing goes further and slower .. some of them involve the surface .. some of them involve notions like the impact and the force its going with when it hits the surface and how far its gone .. and there's all sorts of different things in there .. certainly surface is an ingredient they're talking about

625T yes .. yes .. the skiddiness

R the skidding .. there's a lot about skidding isn't there .. that's right/

T yes

628R /and the problems that provides .. yes

((T watches end of lesson on video .. this continues on Side B))

2/5/84-AT13B (Interview continued) 9

((reviewing videotape of lesson 1/5/84-VT3); section at end where pupils report back about their findings on rolling cars down ramps and in some cases offer their explanations and relate these to their predictions and hypotheses at the start of the lesson - notably Steven and Mark. T built his narrative from these and his remarks about their ideas using his familiar 'plenary' technique. In this interview he comments critically on his performance, attributing it largely to the limited time he allowed, it also includes some incidental material on pupils' ideas and teachers' responses to these eg:-))

010T What happened there of course was .. you remember the beginning of the lesson where he (Mark) had one hypothesis and Steven had the other hypothesis

R yes .. that's right

T he ended up .. he seemed to be interpreting it towards Steven's way of thinking and I think he was .. his results were quite good .. in fact they were very good .. and then Steven had a couple of wrong results in with his lot so .. or else there was this friction problem on the wheels .. the more weight you put on it .. it squashed it down on its axle and the wheel arches started rubbing .. and I don't think he noticed it so he's going to say any minute ((referring to videotape being viewed)) some -thing like "and he's right - I mean I was right up to a point .. but after this point something else starts happening."

020 ((T watches and listens to own handling of those and other pupils' reporting back; comments on it, eg:-))

033T I should have followed that up you know .. I've not given Steven time to think

070T I should have given them a lot more time/

I rushed through it too much to get quite a few pupils contributing () and it confused matters really

192T I'm not keen on what I've seen of the round off

mm .. yes .. dis.. dissatisfied with that .. erhm ()

195R you're saying basically because you didn't give them enough time to elaborate ideas?

T yes .. that's right .. and also because I tended to cut them short .. erhm .. no .. not explore an idea and probably led to more confusion if anyone's listening because I think it became very .. bitty ... it wasn't very entertaining and I'm sure ()

R mmm .. did you find it possible to have the sort of conversation you didn't manage to have there when you were going round the groups? So that you would elaborate an idea and say "Why do you think?"

T yes .. a little bit more and a little bit more this morning when they wrote about it

2/5/84-AT 13B 10

R right .. so they came back to that?

T yes

R that was .. sort of consolidating it

((further discussion of T's favourable impression of how pupils tackled the lesson; this recall unstimulated by video which is now off))

R what about the recording .. because erhm .. another of your big suggestions was that .. the pressure of recording?

T yeh .. yeh

R stops them thinking about it .. in this one you stressed that they might need to keep a record of the results

T yes

R but not emphasised the actual written product/

T that's right

R /() a bit later on

T the recording there .. that they did in that lesson .. it .. I think was .. vital because other wise they would have been () a meaningless set of activities

R mm

T mmm .. and I just said to them .. today ... "Just tell me what you did and show me some results and then but I'm most interested in what you found out

R mmm

T and .. erhm .. I've usually got about a page of A4

R yeh

240T and .. erhm its pretty .. erhm .. there's nothing elaborate abut it all .. it shouldn't have taken long to do .. these things always do spin out to the length of time which you give them

((after some recall by R of the themes and strategies agreed for monitoring and a pause T spontaneously volunteered his thoughts and plans aloud and reflected on possible future activities in the term))

263T not quite sure where I'm going to go from here

R mm

T .. with the term being so bitty

R yeh

27/5/84-AT22: Interview at half term

((T talks about his plans and progress - his intended sequence after half term is from vehicles to Toys to Playgrounds to Bicycles. Only connections between these is the opportunity to make things, the order is 'just as it occurs', seems 'the right way'.

Present topic contrasts with normal pattern, eg in earlier one on light. In this one activities/things dictate ideas, whereas normally set concepts would dictate choice of resources and activities and then the sequence would arise from the logic of what was to be learned. Either pattern seems suitable for topic-based work.

T Teaching in present case can be done as need arises with individual problems. This can however be slow or frustrating eg in the last session before half term (25/5/84). Reflecting on the original aims the teacher expressed concern over slowness of teaching particular concepts because they are organising themselves and learning the skills of this.) Halfway through any topic like this .. you .. you come to a point where you think .. that .. you're not getting on as well as you thought you might do .. you're not getting through things as quickly and efficiently .. because you're letting them organise themselves and they're still very bad at organising themselves .. but thats the whole point of letting them do it ((laughs)) that they're going to get better at it

R yeh

T and I don't think they'll get better at it till they've tried it out

((He rejected my suggestion that a tension might exist between his aims concerned with those skills and aims for knowledge; he said that he was not presently concerned with teaching specific things such as friction or gears, those would arise and be dealt with; rather the tension was over his feeling of wanting to move them along while they seem to be spending a lot of time on basic bits of material and making of things to use later on he speculates that they may be wasting time - he would normally expect to see more in the way of products: an answer to direct question from R))

025 ((asked if this was true of all pupils he noted as exceptions Luke, Danny and Dean's group ("because they're the sort of organised group they are") compared with say Rosie and Elaine who seem to be getting it wrong and doing it over and over again without any clear idea about what they're trying to achieve and he has a similar sort of feeling re:
030 T Rebecca "that she hasn't a clear enough idea in her own head of what she wants the thing to be in the end .. is putting off the evil hour of putting it all together and trying it out. The whole idea is to make it, try it out/test it, and then go back and change it ... but they're not at the point of being able to do that quickly and efficiently enough
035 so we're getting bogged down there's a bit of a tension there in my own mind))

27/5/84-AT22

2

R What would influence you to interfere or not interfere .. to push them on or to let them mess about?

T I think largely ... erhm your own .. feeling as a teacher that you don't don't want to waste time .. because you know that you've only got a limited amount of time .. and you know that there is a lot of things you could be doing .. that would be useful to the children .. and also feel that .. if you let them mess around too much .. this will become .. a normal state of affairs .. once they will .. just fill the available time with .. useless activities and so you must .. one of the whole purposes is to see them working in an organised way on their own ideas .. and working efficiently and finding their own efficient system .. so thats thats where the big problem comes .. you see children wasting time and you have a limited amount of time you've got five hours a day in school and you spend two and a half of .. those hours on what is effectively quarter of an hours work .. there is a great tension in the feeling you've got .. that you ought to be doing something else with the children .. you realise that the parents wouldn't be very happy with that sort of .. activity .. you realise that other teachers will possibly (think) "what were you doing that for?" "Why - what is the motive behind that?" It may not be very clear and sometimes you think to yourself "Is it clear?" why we were doing that?"

R Yeh

T so on the one hand I want to give them time and space to develop their own ideas but on the other hand I don't want to hang around just (pratting) about .. so you've got a problem .. I've got a problem .. because I'm trying to keep them doing it themselves I'm .. I could make it much more efficient by saying "Now in this next quarter of an hour period I want you all to glue the chassis together" and we'd all glue chassis .. "and when you've glued your chassis you'll stop and read your book" and then we'd all glue bearings. Now that would be efficient and they'd get through it quickly .. they'd do it much better than they're doing it at the moment .. that wouldn't be getting what I want them to do .. to get out of it that it .. independence and being able to organise themselves .. there is a great tension there .. and the product would be better

R Now if we just just ask about Dorothy first and Debbie perhaps we can talk a bit more about that problem about .. independence thinking for themselves and what it means to you .. I mean what about Dorothy and Debbie because you've mentioned the other groups ()

T mmm .. mmm you see just talking about Dorothy because Debbie's not doing much she's .. she's finding the mechanics of it very difficult .. like just gluing together accurately and neatly .. that in a way is getting in the way of what I'm aiming for her to do erhm .. so that is a problem .. she in fact in someways more .. more direction .. more clear direction .. the mechanics of putting the thing together

R mm .. and have you been .. responding to her problems and Luke's problems or absence of them or whatever and Rebecca's in different sorts of ways?

27/5/84-AT22

3

T trying to but not in .. not in different enough thinking about it actually .. I've been trying to say give Dorothy still time to do it herself and to do it .. do it herself and probably I ought to be
080 sitting down with her to say for say five minutes "do it exactly like this .. and this is how you'll make a successful model .. and then when you've made a successful model you can then try it out" I'm maybe giving her a bit too much rope to hang herself at the moment

R did you get a chance to .. actually find out how they're getting and how they feel about it and whether they need more or less help or not?/

T no I'm just .. not actually just .. just the feeling you've have going round .. you're too busy and I think sometimes you just because you're too busy .. you can't sit back enough and think about it

R I mean I know what it feels like to be in

T yes

R / the middle of it although I'm not in the middle of it .. I mean I'm I'm opting out really () I'm sat back but you've got all that to pick up as well

T yes thats right .. I think there is the world is too much with you .. when .. you're () those lessons .. you're trying to nip round too much .. and .. doing it all rather badly rather than doing one
090 or two things well

R what about .. if we could go over .. you remember those sort of original intentions you had and the ones you referred to I mean you've said individual, independence, initiative .. I mean can we take it a bit more that .. sort of what is it you're after .. as I wrote it down it was fostering enquiry in terms of pupils readiness to pursue their own ideas and think for themselves plan and organise their own investigations I mean

T mmmm .. so at the moment the mechanics of .. just getting there are getting in the way

R well what sort of .. things do you think are problems not in the .. the task but in kids that prevent them from pursuing their own ideas? for example not .. not what you do or don't but I mean why shouldn't they be able to what are you trying to act on?

100 T (long pause) the fact that they've had no practice at it .. basically

R yeh

T they get very little practice at it and so that's a major problem the second problem it seems to me is just that there is a problem to be solved ... they they can't see that there is an investigation to do here .. because you've got to extract in an abstract way erhm something which you can check with those tanks .. to play with that just seems .. natural .. but then when you have to postulate some problems which you can go and solve about those tanks or () erhm thats

27/5/84-AT22

4

115 a different skill entirely .. not a skill again that they've got I think .. and then .. what I've found quite clearly with this group and with most is that when you've done your investigations its to use the results which you've got ... constructively rather than just saying "here's my results .. and I'll say anything that comes into my head" .. use those results to actually say that you they've found this particular thing

R mmm ... and I mean you can think of instances of you actually doing that and thats .. how you've what led your lessons ... or raised comments to do those sort of things?

T that's right .. () what also gets in the way with that sort of thing is that you've got to give children a chance to talk .. a chance to interact very freely if you're going to do that sort of thing .. and because of that ... children .. (say they've messed about) or with this class they've got an inherent ability to just chatter .. to just waste their time .. and so its difficult for you as a teacher to stand back and say "you are obviously not talking constructively ... and you are just wasting your time" .. so I think those things get in the way

((Discussion of feedback effects of my presence and recordings and what can be helpful/influence and what may be withheld at present or not sought plus elaboration on pupil interviews and specific ref to my comments on openness of his task and my interpretation and general discussion of how teachers and observers infer pupils' involvement;TV programme and pupils' response and use of ideas from it, eg propeller/tube by groups))

305 R asks how well he feels he has carried out his intended strategy of not forcing ideas on pupils. T feels he has given pressures of no's, limited time with individuals, wanting them to get on .. leaving him to offer short cuts to problems .. one idea he has suggested can spread round class with this organisation; occasionally he intervenes to prevent pupils spending hours getting a failure and becomes more directive (eg E; Do's glueing inadequately) which is legitimate, especially
365 with use of tools and techniques

R's summary of this as use of materials/skills agreed with by the teacher as something he is clear in his own mind needs direction (he gives eg) - compared with his volunteered eg of tank testing when he felt that he didn't push his own ideas rather sought clarification of these and enabled them to test them

410 T R summarises and T agrees that the role he uses is "where they've got ideas .. don't do much except help them in their own clarifying where there are material or skills be quite prescriptive"

430 T Above related to earlier expressed approach to skills teaching as need arises - "I've a feeling that until you've tried yourself (ie skills and materials) you won't understand.")

27/584-AT22

5

((Discussion on how to translate intentions into practice with individualised teaching in a busy classroom follows. Teacher notes he often deliberately implements intentions with individuals, if several can sometimes pick them off one by one, sometimes has to go against intentions if XS to cope with. Occasionally has time to stop and look round - in that sort of lesson once they've got started 15-20 mins, often happens but not anticipatable

- 500 R comments at some length and asks more on use of time by pupils
T happy with time provided but some pupils not used wisely; lesson lengths, no of lessons, reasonable he feels he is realising objectives re recording as only doing it where he feels necessary for them to sort out ideas and get results clear. T reports he feels that they've
- 550 learnt an awful lot about structure and friction although not much taught systematically, judging by comments and writing, achievements by pupils. All realise rough surface has lots of friction, they think about how to join wood for testing structure
- 565 R probes teachers language and teaching of friction and his perceptions of pupils' understandings of friction; these are not entirely consistent with my observations and might be compared with field notes of relevant lessons - x ref))

T I think most of them use it pretty accurately .. that word friction

R do you use it with them (in conversation)?

T yes I think I do yes

R and you've used the words just now about rough surfaces. I wonder if you've got a erhm set of words that you thought were appropriate or .. ideas that you/

T no but just/

R or just as it comes?

T as it comes but erhm .. yeh as it comes really what the actual (classroom conditions) dictates

((R contrasts with secondary approach notes and asks about his assessment of pupils' understanding of friction:-))

T I think I'd just say that they've erhm .. had various ways to they understand friction in that they've had a couple of opportunities to one either to reduce it and they've been varying .. had varying degrees of success in reducing friction and they've showed by the skill they've had in reducing friction say between the wheels and the bearing or between the wheels and the chassis and between erhm the propellor and the body of the .. housing .. that sort of thing that they've actually reduced the friction and so they must have understood what they were trying to reduce .. that they were trying to reduce this rubbing thing and the surface the bigger the surface rubbing the less erhm the more friction they'll be .. and they've also had chance to increase friction .. between say the wheel and

27/5/84-AT22

6

the surface its running on .. so yes I'd think I'd only point to the fact that they've had opportunity to meet with in a practical sense ... and have either overcome it or lessened it .. or they've increased it where they're needed it .. so not had a lesson where friction is our friend and friction is our enemy kind of thing .. but well they've done that practically .. they may not have got it all sussed out in nice compartments in their mind just what they've done but when it comes to doing it in say second year physics it will be clear to them when the teacher talks in those terms that this is what they've been doing and I don't see that its my job in a primary school to systematically teach science .. I see its my job to give them a wide range of experiences which will enable them to make sense of science with a big S, later on ... cause thats .. I don't think thats what primary science is about .. not teaching discrete packets of knowledge .. its about giving lots of experiences which will then come together later on ... maybe come together in say the case of someone like Luke or S ((Teacher's son)) or someone like that very early on when they start to weave together their bits of knowledge to make .. you know .. really good bits of cloth .. but in the case of someone like Dorothy they just ... give her an () about these varying various lines various bits of the world which just wouldn't make sense otherwise .. but then later on as she gets more mature and older for her to be able to relate back to the experiences she's had here (to stick together) .. I couldn't give you a check list of the things they would have learned and the things I've intended to teach .. but I could say the things which you've stated along the line .. given them experience of

R and they'll be picked up .. partly in later science studies in secondary school?

T mmm .. mm

R partly in real life ()?

T I think real life .. yes thats right .. and erhm in later lessons in my class .. because its nice to see that they're making connections between things they've done .. even last year

R mm

T and things they're doing this year and things they've done in lesson and things they're doing in another lesson

R if thats .. it sounds like a continuous process .. you're doing something which is being built upon more or less

T yes

R in informal and a formal way .. does that apply before they come to you? () now are there things that they've brought to .. to your activities now?

T mmm

27/5/84-AT22

7

R /that will .. relate to their understanding of .. well say friction?

T do you mean things that they've done in past classes?

R school .. or out of school or/

T oh I think so .. yes out of school say things like erhm .. slippery shoes and non-slippery shoes .. yeh ice and sliding on ice .. what makes a good slide and what makes a bad slide erhm .. that sort of you know () bike brakes and things like that ... making their bikes run smoothly .. they've obviously had lots of experience in that way .. this is just taking it one

R so they had some understanding of friction before or not?

T yes I think so a lot of them obviously have

R did they have .. any vocabulary to go with it before do you think? Because you said now that they've .. they've mentioned terms .. ways you've talked about it .. earlier in year ()

T depends

R depends?

T I mean someone like William probably doesn't .. still doesn't have much of a vocabulary to go with it .. while someone like Luke probably came with a fair degree of specialisation

((end of side A; continues briefly on side B with T talking of sources of experience and understanding of some pupils in activities at home, eg playing with technical kits, in their own intelligence; he goes on to say that he plans that structure will be taught more systematically later finished with enquiry skills and finding that rigidity depends on certain things, not taught as discrete packets of knowledge))

APPENDIX 4: DATA USED IN ANALYSIS OF EACH CHAPTER OF THE STUDY

Data used in Analysis of Chapter 6 - Situation

Date	Type and Content	Code
12 October	audiotape of interview with teacher	12/10/83-AT1A
20 March	audiotape of interview with teacher	20/3/84-AT9
12 April	audiotape of interview with teacher	12/4/84-AT11A
27 May	audiotape of interview with teacher	12/4/84-AT11A
24 July	audiotape of interview with teacher	24/7/84-AT33
13 July	audiotape of interviews with pupils	13/7/84-AT31
18 July	note of discussion with LEA advisers	18/7/84-WN
20 July	telephone conversation with head	20/7/84-WN

Additional data

19 March	and other fieldnotes for layout of classroom	19/3/84-FN
	Pupil's jotter and drawing of plan of school collected	13/7/84-PW
	Contacts with teacher before and after confirming career details -nd	
18 May	Comment on press report	18/5/84-FN

Data used in Analysis of Chapter 7 - Teacher's Theories

Date	Type and Content	Code
12 October	audiotape of interview with teacher	12/10/83-AT1A
28 February	teacher's written comment on 12/10/83	28/2/84-TW
20 March	audiotape of interview with teacher	20/3/84-AT9
12 April	audiotape of interview with teacher	12/4/84-AT11A
2 May	audiotape of interview with teacher	2/5/84-AT13
11 May	notes of teacher's comments	11/5/84-WN
14 May	notes of teacher's comments	14/5/84-WN
27 May	audiotape of interview at half term	27/5/84-AT22
12 June	notes of teacher's comments leading to	12/6/84-WN
15 June	teacher's written response	15/6/84-TW
13 July	note of teacher's comments	13/7/84-WN

Additional data

12 October	teacher's earlier in-service document	12/10/83-TW
	Videotape of BBC Schools TV programme Uphill & programme notes (BBC 1982)	

Data used in Analysis of Chapter 8 - Planning

Date	Type and Content	Code
12 October	audiotape of interview with teacher	12/10/83-AT1A
28 February	teacher's notes on 12/10/83-AT1A	28/2/84-TW
8 March	written note of teacher's comments	8/3/84-WN
20 March	audiotape of interview with teacher	20/3/84-AT11A
10 April	teacher's written lesson plan	10/4/84-TW
10 April	fieldnotes on observed lesson	10/4/84-FN
10 April	audiotape of lesson	10/4/84-AT10

Data used in Analysis of Chapter 9 - Downhill

Date	Type and content	Code
1 May on	notes of plans in teacher's journal	nd-TW
1 May	fieldnotes on lesson with toy cars	1/5/84-FN
1 May	audiotape of lesson with toy cars	1/5/84-AT12
2 May	audiotape of interview with teacher	2/5/84-AT13
2 May	pupils' written work	2/5/84-PW
2 May	teacher's notes assessing pupils	2/5/84-TW
4 May	fieldnotes and written notes on	4/5/84-FN & WN
8 May	three lessons making models, and	8/5/84-FN & WN
11 May	on teacher's comments	11/5/84-FN & WN
4 May	audiotape of lesson making models	4/5/84-AT14A
8 May	audiotapes of lesson making models	8/5/84-AT14B,15,16
11 May	audiotape of lesson making models	11/5/84-AT17

Also collected

videotapes of lessons on VT3 & 4, slides C to J of pupils models

Data used in Analysis of Chapter 10 - Uphill Struggles

Date	Type and Content	Code
(11 May	written note of teacher's decision	11/5/84-WN)
14 May	fieldnotes on lesson making 'tanks'	14/5/84-FN
14 May	audiotape of lesson making 'tanks'	14/5/84-AT17
15 May	written note of teacher's comment	15/5/84-WN
15 May	pupils' writing in jotters	15/5/84-PW
18 May	fieldnotes of lesson testing 'tanks'	18/5/84-FN
18 May	audiotape of lesson testing 'tanks'	18/5/84-AT19
18-25 May	pupils' writing up of work	18/5/84-PW
24 May	fieldnotes of lesson building vehicles	24/5/84-FN
24 May	audiotape of lesson building vehicles	24/5/84-AT20
25 May	fieldnotes of lesson - work continued	25/5/84-FN
25 May	audiotape of lesson - work continued	25/5/84-AT21
27 May	audiotape of interview with teacher	27/5/84-AT22
3 June	written note of telephone call	3/6/84-WN
7 June	fieldnotes of last uphill lesson	7/6/84-FN
7 June	audiotape of last uphill lesson	7/6/84-AT24
14 May - 7 June	entries in teacher's journal	nd TW

Also collected

videotapes of lessons on VT2 & VT4, copy of TV programme 'Uphill' and teachers' booklet for series (BBC, 1982).

Data used in Analysis of Chapter 11 - Mangonels

Date	Type and Content	Code
(7 June	fieldnote of teacher's decision	7/6/84-FN)
12 June	lesson plan in teacher's journal	nd-TW
12 June	fieldnotes of first mangonels lesson	12/6/84-FN
12 June	audiotape of lesson	12/6/84-AT25
12 June	written note of lesson	12/6/84-WN
15 June	fieldnotes of second mangonels lesson	15/6/84-FN
15 June	audiotapes of lesson	15/6/84-AT26,27
15 June	teacher's written note	20/6/84-TW
15 June	audiotape of pupil interviews	15/6/84-AT27
20 June	copies of pupils work	20/6/84-PW
20 June	teacher's written note	20/6/84-TW
21 June	fieldnotes on 'siege' lesson	21/6/84-FN
21 June	audiotape of 'siege' lesson	21/6/84-AT29
27 June	written note of telephone call	27/6/84-WN
2 July	fieldnote of remote control lesson	2/7/84-FN
2 July	audiotape of remote control lesson	2/7/84-AT30
2 July	pupils writing from previous lesson	2/7/84-PW
(24 July	audiotape & notes of teacher interview	24/7/84-AT33)

Also collected

videotapes of lessons on VT6, VT7. Slides K to R of pupils' work

Data used in Analysis of Chapter 12 - Choices

Date	Type and Content	Code
27 May	videotape of interview with teacher	27/5/84-AT22
27 June	written note of telephone call	27/6/84-ATWN
10 July	fieldnotes of choices of lesson	10/7/84-FN
13 July	fieldnotes of next choices lesson	13/7/84-FN
13 July	audiotape of pupil interviews	13/7/84-AT31
13 July	written note on teacher's comments	13/7/84-WN
19 July	written note on pupil feedback	19/7/84-WN
20 July	written note of phone call to head	20/7/84-WN
24 July	audiotape of final interview with teacher, plus notes made at time	24/7/84-AT33

Also collected

children's work and slides of displays, written note on telephone call from teacher - 16/7/84-WN

APPENDIX 5: METHODOLOGICAL ISSUES AND DECISIONS OVER THE YEAR

Stage One : In the Beginning was the Idea

Some Issues

Where to begin?
What is the problem?
Issues or instances?
Access and agreements
Problems and possibilities
Contexts and constraints
Background and bias
Evidence to consider
Methods to review
Technical hitches
Best methods
Best combinations
What is possible?
Rules and roles
and relationships
Are we agreed?
Then let's begin

Some Decisions

Primary science practice is in need of illumination. Pupils' learning could be related to teachers' plans and actions. Interested teachers stress process and particular priorities. Practice of observation and collaboration plus reading precedes study of site AB: audiorecord and field notes essential for data on action and interaction. Interview and recall and jottings essential for teachers' view. Combination essential for fullness and cross-checking. Audio problems to solve. Video helps and fulfills particular functions. All lessons and work must be sampled. All this to base on teachers' intentions and concerns. All this to formalise and document.

A negotiated framework

Multiple methods

Stage Two : Early Field Days

Some Issues

Entry

Reflexivity

Recording

Reflections - eg

is it working?

Is it possible,

plausible, significant,

So what?

Where is it leading?

Is there time to think?

How does it relate to

literature?

Theoretical sampling

Some Decisions

Be conscious of responses

Look out for, check, record

Be systematic, sensitive, open, collate

and check a-s-p,

review methods

Keep your thoughts to yourself

but keep them

Balance immersion with detachment

Look ahead - can you cope,

can you code,

can you retrieve?

Can you become more selective, or do

you need to collect other data?

"Don't Panic"

Stage Three : "Trapped Inside the Case Study" (Adelman, Kemmis and Jenkins, 1980)

Some Issues

Data Overload

Multiple Methods

Quality Control

Recording and Retrieving

Anticipating Analysis

Any Omissions?

Timing and Testing

Some Decisions

No regrets at richness to date but need to focus now. Views and actions and underlying ideas best explicated by emphasis on report by actors using observation to consolidate and check and contextualise. Interview and spontaneous contribution from teacher proving most productive and relevant. Interviewing and checks to read round. Listen to and learn from tapes of these. Video now mainly for stimulating recall. Coding of records on wider basis continues but homing in on manageable collecting and categorising. Selective site visits now. Collect evidence at points with final week as full revisit of earlier work by class opportune for looking at change and filling out missing detail, feeling suitability of analytical framework, full interviews with pupils and teacher.

Plan exit and analysis

Stage Four : Light at the End of the Tunnel

Some Issues

Completing collection

Arranging follow-up

Exiting

Organising records

Analysing

Validating

Clearing

Disciplining

Some Decisions

In the final weeks as any later will be too late for practical reasons and of doubtful validity. However intermittent checking with the teacher need to be arranged and take up time when he has moved on to new fields.

Meanwhile make a graceful exit and consciously disengage and repay participants. Phase feedback to balance usefulness to teacher and distortion of data. Working records will need to be sorted and copied as a basis for analysis.

Internal and external checks and possible and potential forms of validation to review - eg peer group, audit, role of supervisors.

Based on original agreement get teacher's clearance of case record - he may find this time-consuming.

Material has to be omitted despite its attractions and the time spent collecting. Time has to be organised for using what is selected.

So all there is left now is to analyse, validate and write it up!

APPENDIX 6: PROCEDURES USED IN ANALYSIS OF INTERVIEWS

A note on the procedures followed in this case - 29.3.86

Development of analytical framework

1. During the data collection phase

- 1a. Written and taped data checked immediately and any necessary clarification and cross-referencing completed. Data catalogued and filed for access.
- 1b. Partial transcriptions at first level made and used for trial coding using categories/themes identified at planning phase. Some modification of these and generation of new categories and need for probing or collection of further data. Selective feedback of transcripts and tapes for verification/stimulating teacher's recall and probing his thinking. Notes kept on this.

2. Immediately after data collection phase

- 2a. Initial writing up of sections in combination with other data trialled with audiences of the teacher, group of other teachers, supervisors. (Interlude here for other analytical activities and reading)
- 2b. Transcription system finalised.
- 2c. Detailed transcription of further sections to polish and check techniques.

3. Detailed transcription and clearance

- 3a. Full transcriptions made of all interviews and conversations, typed checked and corrections made with typists.
- 3b. Transcripts read, commented on, cleared by teacher.
- 3c. Master copy of transcripts lodged in Case Record.

4. Analysis

- 4a. Discussion/reading of data analysis/reduction methodologies in general, in this case, and with particular reference to interviews.
- 4b. Categories and framework for analysis systematised and refined from those generated to date in conjunction with literature and foreshadowed themes and need for supplementary methodological and interpretative comments.
- 4c. Copy of early transcripts coded in detail. Repeated 2 weeks later to check reliability of coding and other themes/questions noted. Uncoded transcript provided for supervisor's independent comment. Summary sheet devised.

- 4d Minor modifications of coding and commentary procedures made with decision to code under 16 broad category headings at next stage rather than finer categorisation into 64 used in 4c. (Final 16 headings and original 64 with details attached)
- 4e Analysis of all transcripts by categories plus comments on methodology; identification of potential dilemmas, issues or themes, concepts and cross-references; highlighting of passages potentially useful for verbatim quotes. This done in pencil to produce master copy of analysed interview transcripts plus Summary Sheet for each interview (blank copy attached)
- 4f All category locations and margin notes located on cardex. Cardex for listing locations of 16 coded headings plus methodological comments prepared. 5 files for colour coded copies of transcripts under the 4 main headings, plus one for methodological and other comments prepared.
- 4g Colour coded copies of all relevant pages of transcripts filed in 5 appropriate files.
- 4h Read through all summaries to produce collated/edited version. (see appendix 3)

APPENDIX 7: ANALYTICAL CATEGORIES AND COMMENTS FOR CODING DATA

7.1 Initial Categories

Code entered in l.h margin	HEADING Category subcategory	Criteria, definition, or example of items in each category
SIT	SITUATION	Influences relating to:
SIT Car	'Career	Personal/Professional Career:
SIT Car bac	background	T's character, own education experience, life-history
SIT Car sch	school	colleagues, head, parents, school characteristics
SIT Car loc	local & national	policies, emphases, significant personnel - eg advisers
SIT Car fut	future	concerns re prospects
SIT Cla	Class Teaching	personal/professional development being a class teacher,
SIT Cla pri	primary approach	primary school teaching approaches/understandings
SIT Cla dif	diffuse role	width of role, variety of concerns (social & educational)
SIT Cla cla	class character	particular features of this year's class
SIT Cla chi	children-numbers, individual pupils	particular pupils and size of class influence what should, can, cannot be done
SIT Con	Constraints	influences constraining also include; demands of other
SIT Con cur	wide curriculum	curricular areas to cover, resource limitations, eg material, cost,
SIT Con res	resources	breaks in the term, T's absences/other concerns
SIT Con int	interruptions	children's skills and maturity may restrict activities
SIT Con ski	skills & maturity of pupils	or organisation, or offer opportunities as may local environment, school and classroom layout
SIT Opp	Opportunities	at end of year greater possibilities exist
SIT Opp yea	environment and classroom	T's level of control, confidence
SIT Opp con	stage of school year	freedom to make decisions and mistakes
SIT Opp aut	control & confidence	
SIT Opp aut	autonomy & trust	
THE	THEORIES	T's beliefs about
THE Sci	Science	science in primary school
THE Sci att	attitudes	fostering attitudes, specific and general
THE Sci ski	skills	specific and general skills through science
THE Sci kno	knowledge	understanding built up, content less than concepts
THE Sci app	application	science should be applied and seen as useful by children who
THE Chi	Children	change with age, eg
THE Chi dev	development	what to expect at age 10

THE Chi ind	individual diffs	differ in many ways, eg skills and interests
THE Chi gro	groups & peer interaction	work and play with peers as part of school, may choose time and social and place setting and pupils out of school
THE Chi cul	culture, context	
THE Lea	Learning	affects what learning and experience they bring; and experience basis of learning
THE Lea exp	experience	
THE Lea act	activity	activity by pupils central to science learning
THE Lea mot	motivation	interest needed, may be tapped or stimulated
THE Lea com	communication	talking and sharing otherwise consolidates & restructures learning.
THE Tea	Teaching	Teaching must take account of previous approaches and content taught
THE Tea pre	previous teaching	
THE Tea bal	balance	need for balance within and between disciplines
THE TEa dis	discovery and its facilitation	fostering discovery and open-ended, but also has to guide and direct learning and behaviour
THE Tea dir	direction and guidance	
THO	THOUGHTS	
THO Goa	Goals	T concerned to foster inquiry and attitudes of independent learners
THO Goa inq	inquiry/independence initiative	
THO Goa ide	ideas of their own	readiness to pursue their own ideas
THO Goa pla	plan and organise own investigations	ability to plan and carry out investigations
THO Goa con	conceptual learning	incidental learning in areas of friction, force, structures pursued those by trying holding back his own interventions and ideas
THO Way	Strategies (Way)	reducing and varying recording by pupils
THO Way int	interventions	allowing time for pupils' ideas to be tried
THO Way rec	recording	examining his teaching and learning
THO Way tim	time	basic unit of planning: reviewing possibilities from own bank/reading selecting and shuffling potential activities
THO Way sel	self	ordering and pacing in long term
THO Act	Activities	preparing self, resources, class
THO Act rep	repertoire	
THO Act cho	choosing	
THO Act seq	sequence	
THO Act pre	prepare	

THO Pla	Plans and Evaluations	planning and reflection
THO PI yea	year - long term	nested in long term, set early in school year
THO Pla ter	trm - topic	topics distributed and planned termly
THO Pla wee	weeks - elements	themes/activities over week(s) within topic
THO Pla day	days - short term	immediate practical unit of planning for days/lessons
ACT	ACTIONS	
ACT Les	Lessons	features of particular lesson
ACT Les str	structure	pattern/organisation of lesson and time
ACT Les tas	tasks	nature of pupils tasks
ACT Les rou	routines	use of routinised behaviours (familiar to T &/or P)
ACT Les cha	changes	differences from planned or usual lesson
ACT Tea	Teachers	T's actions & thoughts in-flight
ACT Tea set	setting & closure	re starting/ending lessons and activities
ACT Tea obs	observing	watching, waiting, reflecting,
ACT Tea man	managing	organising, controlling admin, resourcing
ACT Tea dec	decisions	report of decisions in a lesson (stim. or spont)
ACT Pup	Pupils	
ACT Pup pla	planning	planning their investigation
ACT Pup dio	doing	carrying out activity or other observed behaviour
ACT Pup com	communicating	talking, writing or other communication
ACT Pup thi	thinking	pupils mediation of task, evaluation, other thought
ACT Int	interactions	
ACT Int cla	class or large group	eg plenary sessions
ACT Int ind	individuals or small group	T with 1,2 or few pupils together
ACT Int tea	teacher initiated	eg goes to group, stops activity-teachable moments
ACT Int pup	pupil initiated	eg asks question, reports progress or idea

7.2 Final 16 Category Headings for Coding Interviews

SITUATION	(see especially ch. 6)
SIT Car	career/background influences
SIT Cla	class teacher's situation
SIT Con	constraints in situation
SIT Opp	opportunities in situation
THEORIES	(see especially ch. 7)
THE Sci	teacher's theories re primary science
THE Chi	his theories about children
THE Lea	learning and
THE Tea	teaching
THOUGHTS	(refers to Planning Thoughts, see especially ch. 8 but throughout)
THO Goa	teachers goals, for learning, and
THO Way	his strategies to foster that
THO Act	selecting, organising, preparing activities
THO Pla	plans and evaluations for
ACTION	(actions and thinking during lessons, referred to as Thinking-in-Action, see chs. 9 to 12)
ACT Les	re features of a lesson, eg timing
ACT Tea	re teacher's actions
ACT Pup	re pupils' action
ACT Int	re teacher - pupil interactions

These 16 categories were supplemented by less structured commentaries as the basis for summarising the interview data.

APPENDIX 8: PROCEDURES FOR TRIANGULATING ANALYSIS OF INTERVIEWS WITH OTHER DATA

General procedure, following earlier inspection across data sets and detailed analysis of interviews (see appendix 7), was to work from one of major interviews to related data, dealing with one section of the action, or one lesson, at a time. The process involved more movement to and fro, and reference to earlier and later data, as the analysis continued to develop the interpretations reported in the text.

The initial sequence was from the summary of interview, referring to original transcript as necessary, to the fieldnotes and then audiorecord, cross-checking to videorecord. Then refer to other data (eg pupils' work, teachers notes). Identify all cross-references/links from interview to other data. Compile summaries to analyse fieldnotes and audiorecords as follows. The extracts below from analytical memos illustrates the procedure with reference to data on the lesson of 1/5/84 (cf appendix 2B)

Analysing a Lesson From AT & FN (&VT)

An example - 1/5/84 - linked to ie 2/5/84-AT13 (can be explored in relation to earlier & later T statements, actions of T & P, P work and P responses at interview)

- 1 Full transcript produced
- 2 Context and identification (eg pupils, activities, teachers movement, observers actions) clarified from FN (&VT)
- 3 3 pp summary index made including T's interactions with target pupils and whole class
- 4 Copies made of index - initial categories and codings following procedure used for coding interviews
- 5 x refs pursued from coded index and to transcription of lesson from interview (ie 2/5/84-AT13) codes and comments. Other major x refs checked (ie 2/5/84-PW, 2/5/84-TW, 1/5/84-FN, 1/5/84-VT3, 12/4/84AT11A, 1/5/84-AT12B,
- 6 any disconfirmation or methodological matters arising memo'd. Note need for futher triangulation as appropriate. summarise, file the major 'confirmed' clusters of categories → issues, dilemmas, concepts to pursue.

APPENDIX 9: NOTE ON THE ETHICAL FRAMEWORK

A general framework for working with the group of teachers was agreed and details for work with each of them negotiated eg re roles to be taken in classrooms, planning meetings. The teachers were not concerned to formalise the arrangements but I felt it was my responsibility to provide a basis that recognised rights and anticipated any problems, as far as this is possible. My initial proposal submitted to the group for their comment, and to colleagues for a critique was as follows:

Thinking and Practice in Primary Science classrooms

Roles and relationships: initial proposals for the framework

Matters such as the commitment and responsibilities of the parties involved, their roles and relationships, the ownership of reports, and the stance of the researcher, need to be spelled out and agreed. There are both ethical and methodological reasons for these. Teachers may initially feel this to be a peculiar concern of a researcher but will surely want on practical grounds to decide what is required of them and what is offered.

This short statement deals with the general framework and principles for the action and research involved. Particular activities will need spelling out subsequently so that details can be negotiated. A basic principle is that procedures and draft reports shall be agreed with the teachers concerned. Written and other records will be cleared by teachers who will be asked to comment before a final version is filed for use; copies of these will be made available to the teachers concerned. Names of schools and teachers will be changed in public use by RS who will have the right to use the final versions in part or whole.

RS will work with a small number of teachers separately and together to assist and research their thinking and their practice in the primary science that is their concern. Each teacher will be committed to one cycle of activity of about a term in their own school; this will include teaching and observations and collection of the relevant evidence. Individually teachers will keep a log of their own thinking and planning concerned with the focus of the activity and comment on observations and reports by RS. Interviews will be held at intervals to review the process. Together the group of teachers will meet two or three times a term to share and support the separate activities, comment and analyse evidence, suggest themes and hypotheses, and act as a peer group validating and considering the transferability of reports.

RS will provide facilities for the group to work together including secretarial support, resources, information from his knowledge of science education and the work in each school. He will produce records for teachers to check and collate evidence from each school site study as a basis for case study reports.

In the case of George Packham discussions over my roles, our relationship and control of data release were conducted during the early interviews (refer to 20/7/83-WN; 29/11/83-WN; 12/10/83-AT1A (p1,5,6); 20/3/84-AT9 (p1,5,6-8); 2/5/84-AT13A (p2f)).

It was not appropriate to reduce our negotiations to a formal contract but agreement was recorded over:

1. The teachers' intentions and what he hoped to gain from involvement
2. My intentions in collecting and using data for the case study
3. Additional uses which we might each, or jointly, make of data
4. Control over release of data for these purposes
5. Information and feedback to be provided for the teacher, and how to stage this to avoid undue influence on the case. What I would not provide during the study eg my judgements on his thinking
6. Information I would require from the teacher and what were reasonable demands on his time
7. The range of data I would collect
8. Methods of data collection. Possible impact of those.
9. My roles during observation and interviews eg in the classroom I would not intervene, would observe/record and seek to be unobstructive but not disinterested, respond to comments from teacher or pupil but not offer judgements or aim to teach or discipline pupils
10. Arrangements for entry, exit, and relationships with head, staff, other adults.

During the study the teacher's views on my roles and other methodological issues were sought at interview (27/5/84-AT22 (p4,5); 24/7/84-AT33).

APPENDIX 10: CONVENTIONS USED IN TRANSCRIPTION

Conventions Used in Transcription

T or George	The teacher (George Packham) speaking
R	The researcher (Robin) speaking
P	unidentified pupil
P ¹	a different unidentified pupil
3P	three unidentified pupils
Luke	eg of a named pupil
.	silence between vocalisations (each further .  1 second)
{ }	inaudible/uncertain word(s)
(())	explanation inserted in transcribing
<u> </u> or highlight in print form	emphasised utterance
?	rising intonation, as for question, in preceding phrase or word
/	overlap between speakers
" "	quotation by speaker (eg self)
-	hiatus, deliberate pause

Technical Details

Sound recording	was largely done with a Sony TCM-7 Cassette Recorder using the built-in electric condenser microphone set to low sensitivity to reduce background noise. This was used by the teacher, fixed usually to his belt, and gave the best available recording of conversations he held with individuals and small groups as well as class-teaching sessions. Field notes, video record and contemporary checking with the teacher ensured identification of speakers and clarification of any uncertain passages. This substitute for a radio-microphone proved very flexible and accurate in collecting evidence in mobile, unpredictable and noisy tasks. A tie-clip microphone was occasionally used. So was a Sony TCM-3 Stereo-Cassette Recorder, principally for comparison or for interview/group discussion. Stereo separation was useful in some cases.
Video recording	was largely done using an Olympus VX301E Colour video camera, some with a JVC GXN5E.
Transcription	was done initially using cassette recorder in use for recording. Final detailed transcribing done using a Sanyo memo scribe TRC 8700A.

Still photographs were taken sparingly using an Olympus Trip 35RC.

The car to carry all the video equipment, etc, was a Lada 1200 Estate.