



THE UNIVERSITY *of* EDINBURGH

Edinburgh Research Explorer

Dynamic competition between contour integration and contour segmentation probed with moving stimuli

Citation for published version:

Lorenceanu, J, Giersch, A & Seriés, P 2005, 'Dynamic competition between contour integration and contour segmentation probed with moving stimuli' *Vision Research*, vol. 45, no. 1, pp. 103-116. DOI: 10.1016/j.visres.2004.07.033

Digital Object Identifier (DOI):

[10.1016/j.visres.2004.07.033](https://doi.org/10.1016/j.visres.2004.07.033)

Link:

[Link to publication record in Edinburgh Research Explorer](#)

Document Version:

Publisher's PDF, also known as Version of record

Published In:

Vision Research

General rights

Copyright for the publications made accessible via the Edinburgh Research Explorer is retained by the author(s) and / or other copyright owners and it is a condition of accessing these publications that users recognise and abide by the legal requirements associated with these rights.

Take down policy

The University of Edinburgh has made every reasonable effort to ensure that Edinburgh Research Explorer content complies with UK legislation. If you believe that the public display of this file breaches copyright please contact openaccess@ed.ac.uk providing details, and we will remove access to the work immediately and investigate your claim.



Dynamic competition between contour integration and contour segmentation probed with moving stimuli

Jean Lorenceau ^{a,*}, Anne Giersch ^b, Peggy Seriès ^{c,1}

^a *Laboratoire de Neurosciences Cognitives et Imagerie Cérébrale, LENA—CNRS UPR 640, Hôpital de la Pitié-Salpêtrière 47, Bd de l'Hôpital, 75651 Paris Cedex 13, France*

^b *Laboratoire de Psychopathologie et Pharmacologie de la Cognition, Unité INSERM U405, Strasbourg, France*

^c *UNIC Avenue de la Terrasse, Gif/Yvette 91 198, France*

Received 31 March 2003; received in revised form 16 April 2004

Abstract

Line-ends, corners and junctions are important singularities for form analysis, object recognition, depth ordering or motion processing. In this study, we investigate the extent to which processing the motion of line ends depends on the spatial configuration of their immediate surround. To that aim, we used two vertical collinear line segments, translating clockwise or anti-clockwise along a circular path, together with a direction discrimination task. Direction discrimination was measured independently for outer line-ends—at both segments extremities—and inner line-ends—in between collinear segments—using line segments partially occluded by invisible masks such that the direction of either inner or outer line-ends' motion was restricted to a sinusoidal translation along a horizontal axis, and thus irrelevant for the motion task. Under these conditions, access to the direction of inner line-ends is longer and more difficult than it is for outer line-ends. Subsequent experiments show that these effects depend on the degree of collinearity between line segments. Similar experiments were performed after volunteers took a dose of Lorazepam, a benzodiazepine that facilitates the fixation of GABA on GABA_A receptors. The results show that the differences between the processing of inner and outer line-ends is reduced, suggesting that the effect of the surround is modulated by inhibitory mechanisms. Using a simple model, we propose that this effect can be explained by a competition between a segmentation process based on surround suppression and contour integration through long-range horizontal connections, at or prior to motion processing stages.

© 2004 Elsevier Ltd. All rights reserved.

Keywords: Contour integration; Singularities; Long range connections; End-stopping; GABA_A

1. Introduction

Visual objects often occlude one another. As a consequence, singularities (line-ends, T-junctions) exist in the input image and contours of a single object may be fragmented into multiple disconnected segments. Nevertheless, the visual system succeeds in recovering contour continuity and closure of occluded visual objects. This

capability requires that disconnected segments of the same object are integrated into a single contour (contour completion and integration, e.g. Kanisza, 1976), while segments from other objects are segregated to avoid spurious associations (contour segmentation). These processes have recently been studied using pseudo-aligned oriented elements, such as line-segments or Gabor patches, immersed within a background of randomly oriented, otherwise identical, elements (Braun, 1999; Field, Hayes, & Hess, 1993; Kapadia, Ito, Gilbert, & Westheimer, 1995; Kovacs & Julesz, 1993; Pettet, McKee, & Grzywacz, 1998). With these displays, it was found that observers easily detect a target path

* Corresponding author. Tel.: +33 1 42 16 11 83.

E-mail address: jean.lorenceau@chups.jussieu.fr (J. Lorenceau).

¹ Present address: Gatsby Computational Neuroscience Unit, UCL, Alexandra House, 17 Queen Square, London WC1N 3AR, UK.

made of several pseudo-collinear elements, provided that their arrangement respects joint position and orientation constraints corresponding to criteria of good continuity (Beaudot & Mullen, 2003; Field et al., 1993; Hess, Hayes, & Field, 2003; Koffka, 1935). These findings led to the notion that “association fields” (Field et al., 1993) link neighbouring elements with like orientation. Anatomical studies uncovering long-range horizontal connections linking V1 neurons selective to similar orientation (Gilbert & Wiesel, 1989; Sincich & Blasdel, 2001) and electrophysiological evidence that neuronal responses are modulated by the stimulation of the “silent” regions surrounding the receptive field of cortical neurons (Bringuier, Chavane, Glaeser, & Frégnac, 1998; Kapadia et al., 1995; Knierim & Van Essen, 1992; see Seriès, Lorenceau, & Frégnac, 2004, for a review) led to the suggestion that association fields reflect non-linear interactions through long-range horizontal connections in primary visual cortex, although feed-back projections from “higher” areas could also be involved (Hupé et al., 1998; but see Hupé, James, Girard, & Bullier, 2001; Stettler, Das, Bennett, & Gilbert, 2002).

In addition, ample evidence suggests that contour integration and segmentation rely on the presence, nature and location of singularities such as line-ends, corners and junctions (Biederman, 1987; Nakayama & Shimojo, 1990) that may result from accidental occlusion—extrinsic features—or belong to visual objects—*intrinsic features*—(Nakayama & Silverman, 1988; Shimojo, Silverman, & Nakayama, 1989). The strong influence of these features on contour integration has been probed with static as well as moving displays (Lorenceau & Shiffrar, 1992; Lorenceau, Shiffrar, Walls, & Castet, 1993; Shimojo et al., 1989). Shimojo et al. (1989) have suggested that extrinsic line-ends were discarded prior to contour linking, whereas intrinsic terminators—belonging to the contour itself and signalling a “real” discontinuity—prevented contour as well as motion integration. Thus, when presented with occluded objects, the visual system must not only combine contour fragments to recover object’s shape, but must also be able to determine the existence, nature, and location of singularities in order to segment contours into distinct objects. How singularities are processed remains a matter of debate. The fact that end-stopped or surround-suppressed cells, whose inhibitory zones shape their selectivity to line width and line length, (De Angelis, Freeman, & Ohzawa, 1994; Hubel & Wiesel, 1968; Li & Li, 1994; Orban, Kato, & Bishop, 1979) has made them a plausible physiological substrate for the computation of singularities (Dobbins, Zucker, & Cynader, 1987). This view has gained support at the psychophysical level, as Yu and collaborators (Yu & Essock, 1996; Yu & Levi, 1998a, 1998b, 1999), characterized end-stopped “perceptive” fields that share many features

with end-stopped neurons, including their cortical origin, their insensitivity to phase and the selectivity of their end-zones to spatial frequency and orientation. Recent electrophysiological evidence (Pack, Livingstone, Duffy, & Born, 2003) further indicates that many end-stopped cells possess the required direction selectivity to encode the direction of moving singularities (see also Van Wezel & van der Smagt, 2003).

We sought to examine the dynamics of possible interactions between contour integration and segmentation by examining the ability of human observers to process moving singularities—line-ends—embedded in discontinuous collinear contours. In this study, motion discrimination is used as a probe to uncover hypothetical differences between the processing of inner and outer line-ends. We show that discriminating the direction of line-ends, as measured through response times and error rates, takes longer and is more difficult for inner line-ends—located in between contours—as compared to outer line-ends. In additional experiments, we find that this differential effect is reduced after an uptake of Lorazepam, a benzodiazepine that facilitates the fixation of GABA on GABAA receptors, suggesting that, in agreement with physiological studies (Sceniak, Ringach, Hawken, & Shapley, 1999; Sillito & Versiani, 1977), inhibitory mechanisms are involved in line-ends processing. We propose that these effects result from a dynamic competition between contour segmentation and integration at, or prior to, the early stages of motion processing and show that a simple model implementing a competition between orientation-dependent facilitation through long-range connections and short-range inhibition is able to satisfactorily simulate the experimental results.

2. General method

The experiments described below are designed to test whether discriminating the direction of unambiguously moving line-ends depends on the stimulation of their immediate surround. To that aim, we use moving stimuli made of two collinear line-segments partially occluded by rectangular masks rendered invisible by setting their hue and luminance as those of the background (Fig. 1). Therefore, line-ends appear as intrinsic singularities even though they result from occlusion. In the following, the two segments move at a constant velocity along a circular path, either clockwise or anti-clockwise, and observers must discriminate their direction. Four conditions are used:

- In condition 1 (control), no masks are present: thus the four line-ends—2 for each segment—move clockwise or anti-clockwise along a circular path and are relevant to perform the task (all line-ends condition, ALE thereafter).

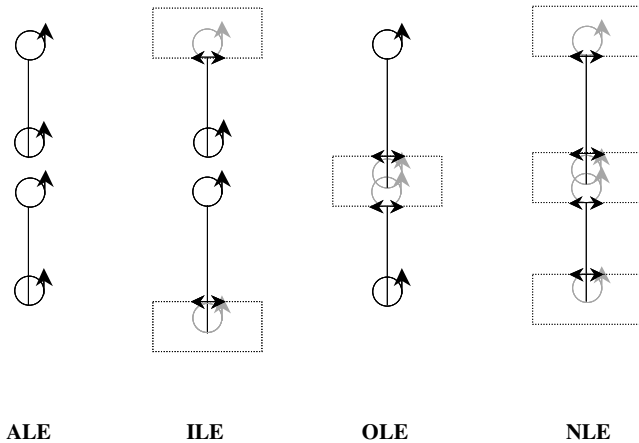

Fig. 1. Experimental display: Two vertical collinear line segments are separated by a gap. Invisible masks—having the same hue and luminance as the background—are positioned so as to cover all (NLE condition), inner (ILE condition) or outer (OLE condition) segments' line-ends. A control condition with no masks (ALE condition) is also used. All four conditions are perceptually identical when the segments are stationary. In the experiments, the two segments translate at a constant speed along a circular path. Depending on the location of the masks, line-ends move clockwise or anti-clockwise, or appear to translate back and forth along a horizontal axis (black arrows). Observers are required to press a key to indicate the clockwise or anti-clockwise direction of motion.

- In condition 2, two invisible eccentric masks cover the outer line-ends, which therefore appear to oscillate back and forth along a horizontal axis, while the unmasked inner line-ends move along a circular path and are the only relevant cues to perform the task (inner line-ends condition, ILE thereafter).
- Condition 3 is similar to condition 2 except that a single central invisible mask partially covered the line segments, such that inner line-ends appear to oscillate back and forth along a horizontal axis, with no rotational component. Only the unmasked outer line-ends moving along a circular path are relevant for the task (outer line-ends condition, OLE thereafter).
- Finally, all line-ends are masked in condition 4, preventing any circular motion to be seen (no line-ends condition, NLE thereafter).

The length of the segments and the positions of the masks are chosen so that all stimuli are identical when static (i.e. the distance between inner line-ends and outer line-ends is identical for all conditions and remains the same during the motion). Observers are required to indicate their perceived direction of motion, clockwise or anti-clockwise, in a simple 2AFC procedure and to respond at random when no rotational component is available in the stimulus. Condition ALE and NLE are used as baseline conditions, whereas condition ILE and OLE are test conditions. Except in Experiment 4, motion lasted until observers' key press. Reaction time—the latency between the motion onset and observ-

ers' response, RT thereafter—and the error rate in the direction discrimination task are measured. Key presses are read after each screen refresh (frame rate: 60 Hz), such that the largest uncertainty in RT measurements is 16.66 ms.

The stimuli displayed on a $1280 \times 1024 \times 8$ bit per pixel, 60 Hz monitor are two white vertical line segments (58.9 cd/m^2 , width: 0.013° of visual angle (dva), length: 0.8 dva) presented in central vision against a grey background (12.6 cd/m^2). They are vertically offset and separated by a gap (0.5 dva , except in Experiment 4). To avoid judgments based on relative motion, no fixation point is provided, but observers are required to fixate the centre of the display, i.e. at the gap in between line segments.

On each trial, one of the four conditions (ALE, ILE, OLE and NLE), is chosen at random. The two segments both move in phase either clockwise or anti-clockwise along a circular path (radius: 0.2 dva , frequency: 0.83 Hz) until the observer's response and then disappear. Observers indicate the direction of motion with the left/right arrow keys of the computer keyboard.

2.1. Experiment I

Preliminary results indicated that errors in direction discrimination systematically occurred, despite the fact that line-ends motion is unambiguous relative to the task (except in the NLE condition), highly visible and available for a long period of time, suggesting either that the task was intrinsically difficult or that observers responded too quickly, resulting in a speed-accuracy trade off. We sought to study the relationships between error rates and response times in more details by asking observers, either to respond as fast as possible (first block), or to respond as accurately as possible (second block). Thus, two blocks of 240 trials—60 trials per condition—one for each task ("fast" and "accurate"), were performed in succession, always in the same order. All observers ($n = 13$), with normal or corrected to normal vision, were students in the Department of Psychology.

2.1.1. Results

The error rates and response times for the two tasks (fast and accurate), averaged across directions and observers, are plotted in Fig. 2 for the four conditions.

A one-way analysis of variance indicates that the error rates for the "fast" task are significantly higher than for the "accurate" task ($F(1, 12) = 16.8$; $p < 0.005$). Although response times for the two blocks or trials are not significantly different ($F(1, 12) = 2.4$, ns), there is still a trend for lower RTs in the "fast" task in all conditions. The different conditions (ALE, ILE, OLE, NLE) yield significant differences both for errors ($F(3, 36) = 62.9$; $p < 0.001$) and response times ($F(3, 36) = 5.03$; $p < 0.001$). Comparisons between the two test conditions

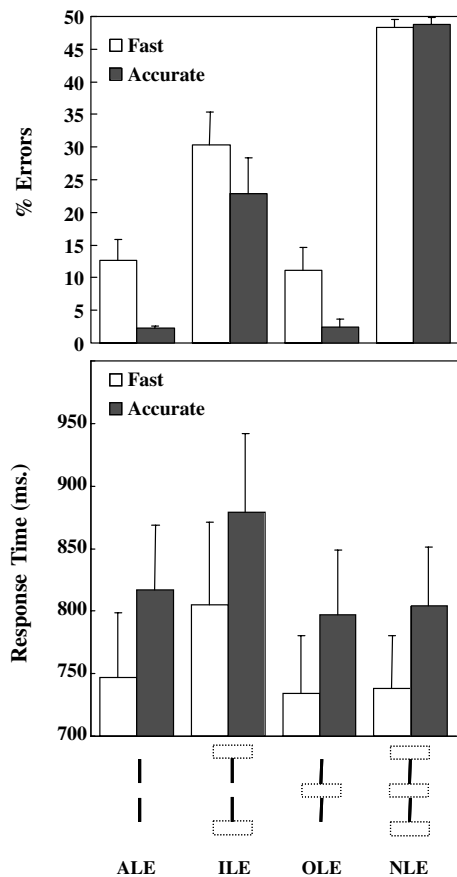

Fig. 2. Results of Experiment 1: Error rates (top) and response times (bottom) in the direction discrimination task for the different conditions. Results for “fast” blocks and “accurate” blocks are shown. Error bars represent 1 s.d.

(ILE and OLE) indicate that error rates are significantly higher ($F(1, 12) = 24.4$; $p < 0.005$) and that response times are significantly longer ($F(1, 12) = 7.8$; $p < 0.005$) for the ILE condition (inner rotating line-ends) as compared to the OLE condition (outer rotating line-ends).

For condition NLE (no rotating line-ends), errors are close to chance level (50%) as expected from the lack of motion cues relevant to perform the task. Significantly different error rates and response times are found between the ILE condition and the NLE condition ($F(1, 12) = 18.7$; $p < 0.005$ for errors; $F(1, 12) = 6.4$; $p < 0.05$ for RTs). Not surprisingly, error rates are also significantly different between OLE and NLE conditions ($F(1, 12) = 18.3$; $p < 0.005$). The results for the ALE (all line-ends rotating) and OLE conditions are not significantly different.

To summarize, the results show higher error rates (by 19%) and longer response times (by about 60 ms.) in the ILE as compared to the OLE conditions. Response times in the ILE conditions are always longer than in all other conditions. Although observers were asked to be as accurate as possible in one of the two blocks of tri-

als, they still made numerous errors in the ILE condition (22.8%), even though the relevant information was available for an unlimited period of time in the region of fixation. This difference is hardly explained by the uneven distribution of circular and linear motions in the ILE and OLE conditions, as performance is similar in the OLE and ALE conditions. The fast response and low error rate in these two conditions suggest that observers used the most salient motion information to respond as quickly as possible. That outer line-ends motion is similar in these conditions suggests that this information was more easily available to a decision process, as compared to inner line-ends. The long RTs and high error rates in the ILE conditions suggest that the visibility of inner line-ends' direction was reduced, presumably because the collinear arrangement of the line segments somehow “masked” their motion, rendering the task more difficult in that particular case. Whether this “masking” effect is related to the specific collinear arrangement of the two segments is investigated in the two following experiments where a spatial offset and an orientation difference are manipulated, so as to break collinearity.

2.2. Experiment 2: Spatial offset

This second experiment replicates Experiment 1 with varying lateral spatial offsets between the upper and lower segments in order to evaluate the influence of the collinearity between the line segments on the effects reported above. Four spatial offsets are chosen so as to maintain inner line-ends close to the fovea (0, 0.03, 0.11, 0.21 and 0.32 dva). Only the OLE and ILE conditions were tested in this experiment. Observers ($n = 13$), different from those of Experiment 1, performed the direction discrimination task in two blocks of trials. They were required to respond as fast as possible in the first block and to perform as accurately as possible in the second block. The results—error rates and response times—for the two blocks of trials are presented in Fig. 3, as a function of the spatial offset.

2.2.1. Results

As in Experiment 1, observers performed differently in the two blocks of trials, but still made numerous errors in the second “accurate” block, despite the lack of time pressure to perform the task. A one way analysis of variance again indicates that there are more errors ($F(1, 12) = 6.3$, $p < 0.005$), and that response times are significantly longer in the ILE condition than in the OLE condition ($F(1, 12) = 5.6$; $p < 0.05$). In addition, response times decrease significantly with increasing spatial offset between segments ($F(4, 48) = 3.08$, $p < 0.05$). Additional comparisons performed on the pooled “accurate” and “fast” data indicate, however, that this

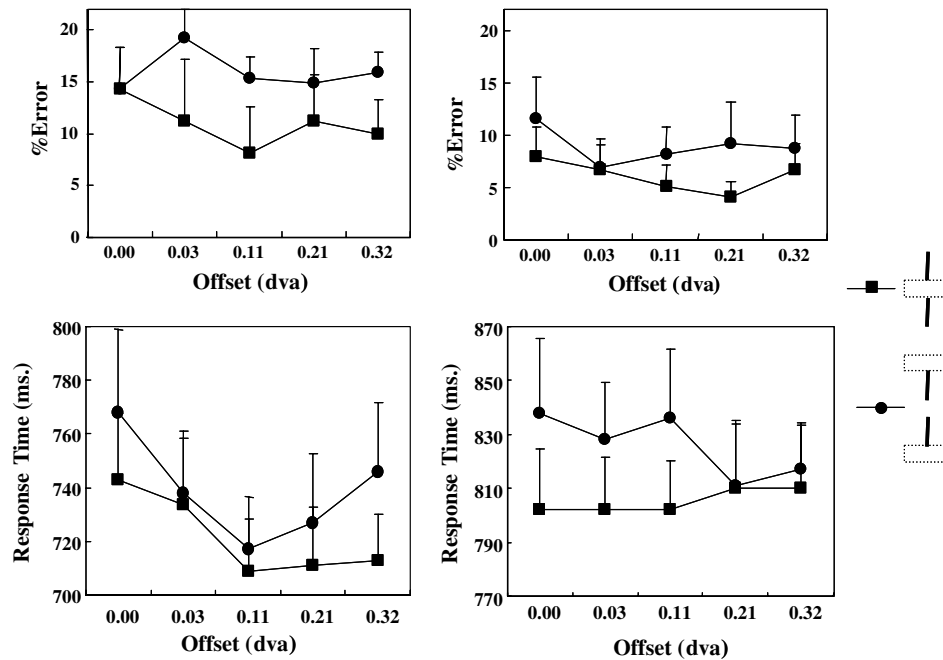

Fig. 3. Results of Experiment 2: Effect of a horizontal spatial offset between line segments. Error rates in the “fast” (left) and “accurate” (right) blocks averaged across observers and direction are shown in the top panels as a function of the spatial offset. Responses times are shown in the bottom panels for the two tasks. Error bars represent 1 s.d.

effect is restricted to ILE conditions as response times decrease significantly with increasing spatial offset in the ILE ($F(4,48) = 2.6; p < 0.05$) but not in the OLE condition ($F(4,48) = 0.97, ns$).

Although the error rate also tends to decrease as the spatial offset increases, which may reflect decreased interactions between segments, this trend does not reach significance ($F(4,48) = 1.6, ns$). At this point, it is not clear whether this trend is not significant due to the small spatial offsets employed, which would suggest that the effect is not sensitive to small misalignments and does not depend on a highly localized mechanism or whether it is due to an effect of retinal eccentricity that increases with spatial offsets, which would suggest a retinal heterogeneity of the dynamics of line-ends processing.

2.3. Experiment 3: Relative orientation

To test further the dependence of the effects on segments’ alignment, we introduced an orientation difference (60°) between the upper and lower segments while maintaining the distance between inner line-ends. The same experimental design as before was used, except that only the ALE, OLE and ILE conditions were tested. Two blocks of 240 trials each (one for aligned vertical segments, one for oblique non-aligned segments) were performed by five observers familiar with psychophysical testing but unaware of the specific goals of the study. Only the “fast” task was used in this experiment.

2.3.1. Results

The percentage of correct responses and the response times averaged across directions and observers, are presented in Fig. 4 for the three conditions. The results are clear cut: ILE, OLE and ALE conditions yields similar response times and error rates when the relative orientation between segments is 60° ($F(1,4) = 1.2, ns$ for error rate, ($F(1,4) = 2.3, ns$ for RTs) whereas in the 0° conditions, the same results as in Experiment 1 are found, with the ILE condition yielding longer response times than the ALE and OLE conditions ($F(1,4) = 7.7, p = 0.05$). More specific comparisons indicate that RTs are different between OLE and ILE conditions for 0° ($F(1,4) = 12.47, p < 0.05$) but not for 60° ($F(1,4) = 1.9, ns$). However, the differences in error rates do not reach significance ($F(1,4) = 1.61, ns$). It is worth noting that the mean RT is shorter by ~ 250 ms in this as compared to Experiment 1. This difference presumably reflects the fact that the observers were highly familiar with psychophysical testing in this experiment.

The disadvantage found at 0° in the ILE condition disappears in the 60° condition. Thus, breaking the collinearity between segments shortens the response times, suggesting that this disadvantage results from a time consuming competition between contour integration and contour segmentation with aligned collinear segments, such that access to the direction of inner line ends is perturbed, taking more time and/or yielding more errors.

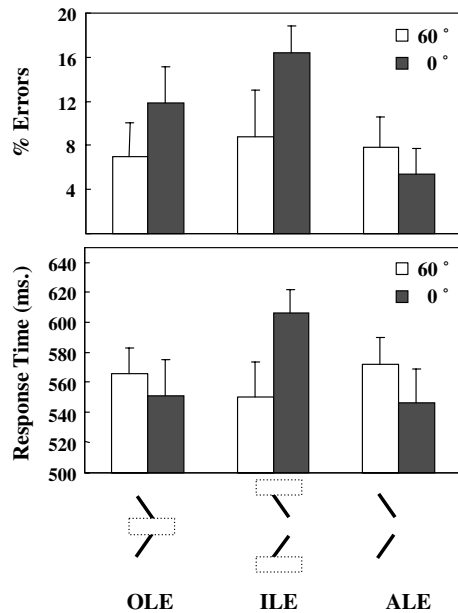

Fig. 4. Results of Experiment 3: Effect of relative orientation. Error rates (top) and response times (bottom) averaged across five observers for conditions OLE, ILE, ALE are shown when the relative angle between the upper and lower segments is equal to 0° or 60°. Only the “fast” task was used. Error bars represent 1 s.d.

In summary, the results of Experiments 1, 2 and 3 suggest that the ability to recover the direction of line-end’s motion depends on the spatial configuration of their immediate surround, and is not due to the different location of inner and outer line-ends in the visual field (i.e. central vs. eccentric vision). Note that even if this eventuality were correct, the data would be at odds with the prediction that visual processing is faster in the attended central region of the visual field (e.g. Posner, Snyder, & Davidson, 1980), i.e. in between segments, where observers were asked to direct their gaze. Indeed, RTs are longer when line-ends are seen foveally, as compared to the more eccentric outer line-ends, but only when they are embedded within aligned collinear segments.

We mentioned in Section 1 that contour integration is thought to be related to long-range facilitation through horizontal connections, while segmentation based on line-end processing is commonly associated with suppressive interactions as those described in hypercomplex end-stopped neurons. Although both mechanisms are activated by collinear segments, their influence on psychophysical performance may differ, due to the different position of the line-ends relevant for the motion task. Modulating the contribution of these antagonistic processes by altering the balance between excitation and inhibition in the cortical networks involved in the direction discrimination task may therefore differentially affect performance in the ILE and OLE conditions. This

can be done by using a GABA_A agonist that changes the gain of inhibitory neurons.

2.4. Experiment 4: Effect of Lorazepam

To test further the idea that the different performance between the ILE and OLE conditions result from a competition between contour integration and contour segmentation, we replicated Experiment 1 after volunteers were given a dose of Lorazepam, a benzodiazepine that facilitates the fixation of GABA on GABA_A receptors. At the dose used here (0.038 mg/kg), Lorazepam fixates specifically on the benzodiazepine site of GABA_A receptors, but not on GABA_B or GABA_C receptors. Importantly, Lorazepam does not directly elicit responses from inhibitory GABA_A-ergic neurons in the absence of GABA, but only enhances the induced inhibitory activity of these neurons (Mohler, Benke, Benson, Lüscher, & Fritschy, 1995; Smith & Olsen, 1995). Lorazepam is widely prescribed for its anxiolytic, hypnotic, myorelaxant and antiepileptic properties. Beside its sedative effects, which entail lengthened response times, it also alters the oculomotor balance. Although these effects are aspecific and should impair performance in both the ILE and OLE conditions, Lorazepam may also differentially alter performance in the ILE relative to the OLE condition, as processing the line-ends motion needed to perform the task may not rely similarly on inhibitory mechanisms. Previous studies using this strategy have shown that GABA_A agonists such as Lorazepam, selectively enhance the processing of line-ends (Giersch & Lorenceau, 1999; Giersch, 1999, 2001).

2.4.1. Method and procedure

The experiment was conducted in the Laboratory of Psychopharmacology in Strasbourg. The apparatus, the stimuli and the procedure were identical to those described previously except that two gap sizes—the distance between line segments—were used (8.8' and 35.2' of arc). Only the ILE, OLE and NLE conditions were tested. To minimize eye movements and avoid any contamination of the results by a Lorazepam induced impairment of the oculomotor balance (Masson et al., 2000; Speeg-Schatz et al., 2001), the stimuli were viewed monocularly and the duration of motion was limited to 150 ms.

2.4.2. Subjects

Sixteen healthy volunteers (10 women and 6 men) recruited in the University of Strasbourg (aged from 21 to 25 years) participated in this study. Their weight ranged from 47 to 87 kg (mean weight: 67.6 kg). The protocol was approved by the Faculty Ethics Committee. All observers gave their written informed consent and were paid for their participation.

Observers had no medical illness or history of alcoholism, drug abuse or tobacco consumption of more than 10 cigarettes a day. They were not chronic users of benzodiazepines and had not taken any medication for at least 15 days. They were instructed to abstain from beverages containing caffeine or alcohol during 24 h prior to the study. The drug was administered in the morning, after an overnight fast. Observers were randomly assigned to one of two parallel groups of eight observers each: a placebo group and a Lorazepam group (0.038 mg/kg). The drug capsule was given orally using a double-blind procedure. Investigations were conducted between 1h30 and 3h00 after the intake of the drug. All observers treated with Lorazepam were tested again three months later, to check their performance without treatment. All observers were tested with their optical correction, if any.

Each observer started with a 40 trials training session the day before the intake of the drug. Practice was stopped when performance was higher than or equal to 75% correct responses in the OLE condition. On the day of test, the experimental session was preceded by a 20 trials training session.

2.4.3. Results

Analyses of variance were first conducted to compare response times and error rates of the placebo group and the group tested without treatment three months after the drug intake. As performance was identical in the two groups ($F_s < 1$, ns), all subsequent analyses were conducted on the Lorazepam treated observers during and three months after the intake of the drug. Analyses of variance were conducted on both response times and errors, with observers as a random variable. There was one between-observer variable—the day of the test (during and after treatment)—two within-observer variables—the experimental condition (ILE, OLE and NLE) and the gap size (8.8 or 35.2' of arc). The results are displayed in Fig. 5.

Without treatment, the mean response times and the mean error rate were respectively 1098 ms and 23.5%. In the Lorazepam group, the mean response time and the mean error rate were respectively 1436 ms and 28.6%. The mean response time was significantly longer with than without treatment ($F(1, 7) = 17.7$, $p < 0.005$) but the mean error rate was not significantly different in the two conditions ($F(1, 7) = 2.1$, ns).

In agreement with our previous results, observers without treatment are more accurate in the OLE than in the ILE condition (by 17.4%, $F(1, 7) = 9.9$, $p < 0.05$). Although observers are faster by 72 ms in the OLE condition, this difference does not reach significance ($F(1, 7) = 2$, ns). When the results of the placebo and non-treated group are pooled, RTs are significantly shorter in the OLE condition than in the ILE condition, but only for a gap of 8.8' of arc (by 121 ms in non-trea-

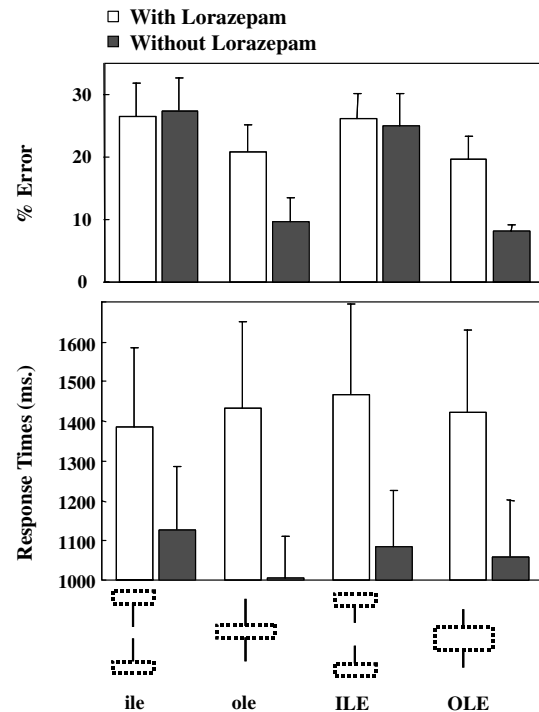

Fig. 5. Results of Experiment 4: Effect of Lorazepam on direction discrimination performance. The top panel shows the error rates for the ILE and OLE conditions and two gap sizes—35.2' (right) and 8.8' (left) with (white bars) and without (black bars) Lorazepam. The lower panel shows the response times for the same conditions. Error bars represent 1 s.d. See text for details.

ted observers and by 124 ms in the placebo group, $F(1, 14) = 7.9$, $p < 0.05$). This results in a significant interaction between the gap size (8.8' or 35.2' of arc) and the experimental condition (ILE or OLE: $F(1, 15) = 5.3$, $p < 0.05$). In the ILE condition, observers tend to be faster for a large—35.2' of arc—as compared to a small—8.8' of arc—gap between segments (by 51 ms and 4.7% in the placebo group and by 55 ms and 2.5% in non-treated subjects, $F(1, 15) = 4.4$, $p = 0.054$ for RTs and $F(1, 15) = 1.9$, ns for errors). This effect of gap size is consistent with previous studies showing that grouping dots or segments into a whole contour depends on the distance between individual elements (Boucart, Delord, & Giersch, 1994; Zucker & Davis, 1988) and may reflect the spatial distribution of the lateral interaction's strength (Beaudot & Mullen, 2003; Polat & Sagi, 1994).

Comparing the error rates between the same observers, with and without Lorazepam, indicates that Lorazepam induces a 11.4% increase in error rate in the OLE condition ($F(1, 7) = 7.9$, $p < 0.05$). This effect is independent of the gap size (11.2% for 8.8' of arc and 11.6% for 35.2' of arc). Error rates are not affected by Lorazepam in the other conditions—ILE or NLE ($F_s < 1$, ns). Taken together these differences yield a significant interaction between the treatment and the location of the rotating line-ends (ILE vs. OLE:

$F(1, 7) = 19.6, p < 0.005$). RTs increase with Lorazepam in all conditions. For a large gap, the increase of RTs is similar in the ILE and OLE conditions (+384ms and +362ms respectively). For a small gap, reactions times increase by 259ms in the ILE condition, by 391ms in the OLE condition and by 258ms in the NLE condition. This increase is not significantly different in the ILE and NLE condition ($F < 1$, ns), but is significantly smaller in the ILE than OLE condition, as indicated by a significant interaction between the day of the test and the experimental conditions ($F(4, 28) = 3.1, p < 0.05$).

To summarize, the main effects of Lorazepam on direction discrimination are the following: (1) Lorazepam induces an increase in error rates in the OLE condition, but *not* in the ILE condition. As a consequence, the difference between ILE and OLE conditions is reduced. (2) Observers are slower with than without Lorazepam. (3) This increase in reaction times is smaller with a small gap size ($8.8'$ of arc) in the NLE and ILE conditions than in the other conditions.

That Lorazepam induces a general slowing down and an increase in error rates is expected and can be attributed to sedative non-specific effects—namely a slowing down of the motor system. However, on top of this non-specific effect, significant differences between the ILE and OLE conditions are found. Several explanations of this effect can be ruled out. These differences are unlikely to reflect a floor effect since the error rate for these conditions is far from chance level (50%), as is observed when all line-ends are masked. Moreover, increased error rates in Lorazepam-treated subjects are systematically observed in other studies, even when the error rates under placebo were 20% or 25% (Giersch & Lorenceau, 1999; Giersch, 1999). It is also unlikely that this effect is accounted for by a narrowing of an attentional window which could account for the decreased performance observed in the OLE condition. If Lorazepam-treated subjects had focused their attention on the inner line-ends, their performance should have been better in this condition than with outer line-ends (Eriksen & Yeh, 1985; Posner et al., 1980). This was not the case, in no subject. Note however, that this could explain the increased error rates found for OLE conditions, as task relevant line-ends are more peripheral than in the ILE condition. Although one cannot reject this possibility on the sole basis of the present results, it is worth mentioning that previous studies with compound letters showed that Lorazepam does not facilitate the processing of local information at the expense of global information processing (Giersch, Boucart, & Danion, 1997). To ensure that the different eccentricities of inner and outer line-ends did not account for the present findings, we performed a control experiment with four moving dots located at segments' extremities. In one condition, two inner dots moved clockwise or anti-clockwise while outer dots translated sinusoidally along

a horizontal axis. In a second condition, the inner dots translated horizontally and the outer dots moved clockwise or anti-clockwise along a circular path. These two conditions yielded similar performance in the direction discrimination task, suggesting that the effects reported in the previous experiments are not accounted for by differences in eccentricity.

Given that ILE and OLE conditions differ only in the location and, most importantly, the spatial context of task relevant line-ends motion, these specific differences are likely to reflect a differential modulation of the processing of these features. At first sight, the increased error rates in the OLE condition relative to the ILE condition is puzzling. Since Lorazepam alters performance in all conditions, which can be attributed to non-specific effects, the lack of effect in the ILE condition appears as a relative improvement for this particular condition. This view is consistent with evidence that Lorazepam facilitates the segmentation process at the cost of the integration process. If Lorazepam-treated subjects segment more easily collinear aligned contours, they may more easily discriminate the direction of the inner line-ends. Lorazepam, through its GABAergic action, may boost inhibition in the cortical network processing the stimuli and bias the competition between integration and segmentation toward an over-segmentation, which counteracts the non-specific influences of Lorazepam, an hypothesis consistent with studies suggesting that segmentation involves inhibitory mechanisms (Sceniak et al., 1999; Sillito & Versiani, 1977). This scenario is tested in the model presented below.

3. General discussion

In the following, we first discuss the relationships between this and previous studies. We then describe a simple model, based on the physiology of contour and line-end processing that can account for our data.

3.1. Relations to previous studies

Several studies indicate that the visual system relies on line-ends to solve the “aperture problem”, as they provide unambiguous 2D information that can be used to constrain the ambiguous 1D responses to contour motion (Lorenceau et al., 1993; Mingolla, Todd, & Norman, 1992; Rubin & Hochstein, 1993). The observation of directional biases with lines tilted relative to the motion axis further suggested that recovering the actual direction of a contour is a time consuming process (Lorenceau et al., 1993; Masson, Rybarczyk, Castet, & Mestre, 2000; Pack & Born, 2001). Although directional biases may reflect the time constant of the motion integration process itself (Lamouret, Lorenceau, & Droulez, 1996; Majaj, Smith, Kohn, Bair, & Movshon, 2002), it

may also arise from the slower dynamics of line-ends' processing relative to that of straight moving contours (Lorenceau et al., 1993), a view that recently gained electrophysiological support (Pack et al., 2003). Psychophysical experiments with *static* displays (Yu & Levi, 1999) also indicate that line-ends processing is delayed by about 70–100 ms relative to contour processing, comparable with the time constants derived from experiments with moving lines. Given the similarities between studies using static or moving displays, it is unlikely that the results with moving stimuli reflect solely the time constants of the motion integration process.

The view that line-ends are used to disambiguate contour motion has been challenged by studies showing that directional and speed biases are observed despite the presence of unambiguously moving line-ends (Castet & Wuerger, 1997; Scott-Brown & Heeley, 2001). In these studies, one (Castet & Wuerger, 1997) or several (Scott-Brown & Heeley, 2001) small gaps are introduced between moving line segments, such that unambiguous line-ends move in a direction and at a speed that differ from that of the ambiguous contours. Under these conditions, directional and speed biases similar to those found with a single continuous contour are still observed, suggesting that observers were unable to use the information carried by unambiguously moving line-ends. The additional observation that speed biases are greatly reduced when the collinearity between line segments is broken (Scott-Brown & Heeley, 2001), further suggests that processing line-ends motion is impaired when they are embedded within collinear segments. The present results may help understanding these findings. Processing the direction of line-ends located within collinear contours—i.e. ILE condition—is more difficult and longer, by about 60 ms, than processing line-ends not embedded within collinear contours. Therefore, the long processing times found for inner line-ends may limit access to their direction of motion, which may explain the results of Castet and Wuerger (1997) and Scott-Brown and Heeley (2001) summarized above.

In the following, we propose that the lengthened discrimination of moving line-ends located in between collinear segments results from a dynamic competition between contour integration and contour segmentation. Such competition is a key to many computational models of contour (Grossberg & Raizada, 2000; Somers et al., 1998) and motion (Liden & Pack, 1999) integration and segmentation processes, and is believed to rely on an interplay of inhibitory and excitatory interactions with different cortical dynamics, as has been described in physiological networks in early visual cortex (De Angelis et al., 1994; Hubel & Wiesel, 1968; Jones, Grieve, Wang, & Sillito, 2001; Li & Li, 1994; Sillito & Versiani, 1977; see Seriès et al., 2004 for a review). We have implemented a simplified version of such competitive process-

ing as a tool to analyse the dynamics underlying the processing of ILE and OLE, with or without Lorazepam, and the speed accuracy trade-off found in our data set. In this respect, our modelling effort may not offer a new architecture but serves to test the plausibility of our interpretation of the experimental results.

3.2. Model

The physiological substrate of contour grouping and contour segmentation is thought to be present as early as primary visual cortex (V1). It has long been suggested (e.g. Julesz, 1981; Lamme, Van Dijk, & Spekreijse, 1994; Li, 1999) that the detection of the termination of a line segment and the segmentation of contours are related to the phenomenon of end-stopping (Hubel & Wiesel, 1968; Jones et al., 2001; Orban et al., 1979) which refers to the property of some cells to be suppressed by an iso-oriented stimulus presented at the end-zones of their receptive field. On the other hand, grouping mechanisms and “perceptual association fields” (Field et al., 1993) have been suggested to be related to collinear facilitation, which refers to the property of some cells to be facilitated by an iso-oriented stimulus presented at the end-zones of their receptive field (Kapadia et al., 1995; Kapadia, Westheimer, & Gilbert, 2000). Both phenomena are thought to reflect modulatory influences from beyond the classical receptive field (Anderson, Lampl, Gillespie, & Ferster, 2001; Somers et al., 1998; Walker, Ohzawa, & Freeman, 2000). They could be mediated by the network of long-range horizontal connections observed within V1, which appears ideally suited for these tasks, as it preferentially connects cells of similar orientation preferences with aligned receptive fields across several millimetres of cortical tissue (Gilbert, Das, Ito, Kapadia, & Westheimer, 1996; Sincich & Blasdel, 2001). These connections arise almost exclusively from excitatory neurons, although 20% terminate on inhibitory cells and can thus have significant inhibitory effects (McGuire, Gilbert, Rivlin, & Wiesel, 1991). Long range facilitation and suppression have been probed with static stimuli and are thought to play a critical role in the perception of form. However, these processes are also observed with moving stimuli. Recent data suggest that they strongly influence the perception of motion, because they affect information that is either already coded in V1, or coded in higher cortical areas that receive inputs from V1 (Pack et al., 2003; Seriès et al., 2004; Van Wezel & van der Smagt, 2003).

In this context, we reasoned that our stimulus might elicit both long-range facilitation and suppression. More precisely, inner line-ends are likely to activate both a population of “end-stopped” and a population of “end-facilitated” cells, while outer line-ends should not involve end-facilitation. Assuming that psychophysical performance relies on the activation of these two

populations, a competition between them might explain why “access” to the moving line-ends is more difficult and requires more time in the ILE than in the OLE configuration.

In our simple model (Fig. 6 and Appendix A), we consider that cells involved in collinear facilitation (Integration cells, *I*) and cells involved in end-stopping (Segmentation cells, *S*) form distinct populations. Both populations are sensitive to an oriented contour placed in their receptive field and function in a competitive manner: when a collinear stimulus is present in their surround, *I* cells become facilitated (collinear facilitation) and suppress the *S* cells sensitive to the surrounding region of space (end-stopping). On the contrary, in the absence of a collinear stimulus in their surround, *S* cells are strongly activated and suppress the *I* cells responding to the same region of space. The *S* cells converge on a theoretical unit that accumulates relevant sensory data over time (Shadlen & Newsome, 2001; Usher & McClelland, 2001). Decision is made when the activity of this unit reaches a given threshold.

This simple model is sufficient to simulate the main features of our data (Fig. 7). It accounts for the increase of reaction times for ILE as compared to OLE condition: at inner-line ends, the *S* cells are suppressed by the collinear stimulus in their surround (via the *I* cells that are activated), whereas they are maximally activated at outer line-ends. As the available input signal

to the decision unit is lower in the ILE configuration compared to the OLE configuration, the time needed to accumulate sensory data and trigger the decision unit is longer, as are the behavioural RTs (Experiment 1).

Given the cortical distribution of long-range horizontal connections, this model predicts a decrease of the suppression of the responses of *S* cells sensitive to the inner line-ends, and thus a relative improvement in the ILE condition when: (i) a lateral offset is introduced between the two line segments (Experiment 2), (ii) the relative orientation of the two line segments is increased (Experiment 3), (iii) the relative distance between the two line segments is increased (Experiment 4).

Why then should Lorazepam produce a *relative improvement* in the ILE condition? Our model gives a possible explanation for this counter-intuitive observation (Experiment 4). In agreement with experimental data, we assume that Lorazepam alters the balance between excitation and inhibition such that: (1) the amplitude of the inputs to the circuits are reduced (non-specific suppression) and (2) the efficacy of the circuit’s inhibitory synapses increases. In the absence of a surround stimulus (OLE), because of (1), the responses of *S* cells are lower than without Lorazepam which in turn lengthen the RTs. In the presence of a surround (ILE), because of (2), the *S* cells induce a stronger suppression of the *I* cells, thereby weakening the inhibitory feedback loop responsible for their own

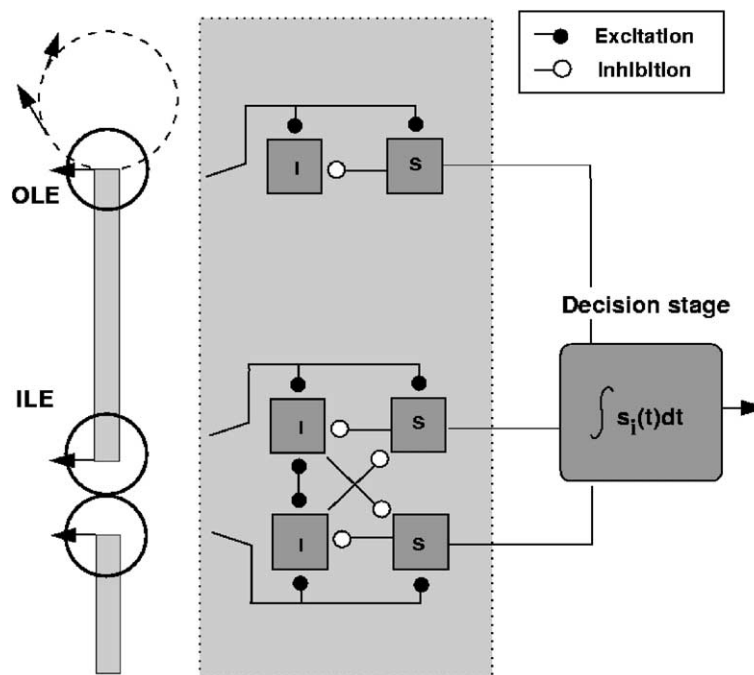

Fig. 6. The model comprises a population of “integration” cells (*I*) and a population of “segmentation cells” (*S*). The *I* cells that have similar orientation preferences and aligned receptive fields interact via long-range horizontal connections (“collinear facilitation”). They suppress the *S* cells sensitive to the RF’s surround (“end-stopping”). The *S* cells suppress the *I* cells that are sensitive to the same region of space (competition). The decision related to the direction of the stimulus is based on the temporal integration of the activities of all *S* cells. Decision is made when the theoretical decision unit reaches a given threshold.

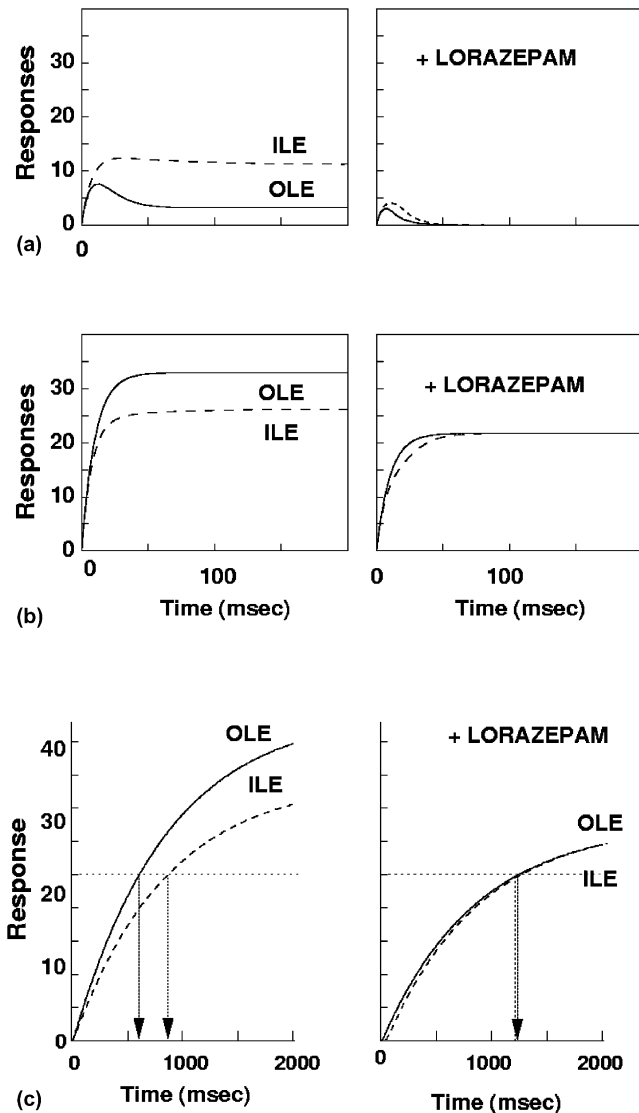

Fig. 7. Illustration of the behavior of the model. The *I* cells (top panel) are more activated by ILE than OLE (collinear facilitation) which results in a suppression of *S* cells at ILE (end-stopping, middle panel), and a longer delay for the decision unit to reach threshold (bottom panel). With Lorazepam, all input signals are weaker which results in a global decrease in the activities and longer RTs. Moreover, the strengthening of inhibitory synapses in the circuit induces a stronger (here full) suppression of *I* cells due to the activation of *S* cells. The *S* cells being disinhibited at ILE respond as strongly as at OLE and the RTs are similar in the two conditions. See Appendix A for details. (a) Integration cells, (b) segmentation cells, (c) decision stage.

suppression (disinhibition). This results in a relative facilitation of *S* cells at inner line-ends, and a shortening of the RTs. If the *I* cells are fully suppressed, the ILE and OLE conditions give similar performances, consistent with the experimental data. The relative response level of end-stopped cells at inner and outer line-ends, and the disinhibition of end-stopped cells with Lorazepam can be considered as predictions of the model that could be tested through electrophysiological recordings.

This model can also account for the data obtained in the “fast” and “accurate” blocks of Experiments 1 and 2, or the fact that ILE and OLE conditions yield significant differences in error rates but not in reaction times—or vice-versa—as in Experiments 3 and 4. Indeed, these patterns of results can be obtained depending on when the output of the decision unit is readout and used to produce a response. If the readout of the decision unit occurs at a fixed duration before or at the time it reaches its threshold, i.e. if observers do respond as fast as possible as in Experiment 1, the difference between ILE and OLE condition should manifest itself in the error rates. If, on the contrary, the readout of the decision unit is done just after it reaches its threshold, i.e. if observers shift their criterion to respond as accurately as possible, error rates should be small in both the ILE and OLE conditions, but response times should be longer for ILE as compared to OLE conditions. Any intermediate situation, resulting from a compromise in the observers’ response strategy, would yield either longer response times with lower error rates, or reciprocally, shorter response times with higher error rates, as was experimentally observed.

Our model does not describe explicitly how motion is processed in V1—or MT. However, it could easily be extended to do so, so as to directly account for motion discrimination performance. This could be done in different ways, depending on whether the processes involved in the integration/segmentation of contours and in the analysis of their motion can be thought of as occurring at different stages/times in visual processing, or on the contrary as being intermingled and occurring simultaneously. We see three alternatives. A first possibility is that the competition between integration and segmentation takes place in non-direction selective cells and affects the inputs to motion processing units. In this scenario, our model should be extended to include an intermediate motion processing stage between the “integration/segmentation” stage and the decision stage. Alternately, one can simply assume that the modeled cells are already direction selective (in an extended version of the model, they could be described as energy-filters, for example). In that case, suppression or facilitation of end-stopped cells would directly correspond to a degradation or enhancement of the representation of motion. A third alternative would be that the phenomenon studied here occurs only with moving stimuli, and depends on the architecture—e.g. the receptive field structure—of motion cells. For instance, one may wonder whether the center-surround organization of MT neurons may account for the data. However, it is not clear how the orientation dependence of the effect or the influence of Lorazepam described herein could be accounted for within this scheme.

We suspect that the phenomenon should be very general, and should occur with static as well as moving

contours, in which case the motion discrimination task only serves as a probe to distinguish between inner and outer line-ends. Whether the competition occurs at or prior to motion processing stages, the outputs of the modelled cells should project onto motion selective cells able to represent information related to the clockwise/anti-clockwise direction of end-lines needed to realize the task, presumably in the MT/MST complex. Additional experiments using a different paradigm and static stimuli should permit to disentangle these different possibilities.

4. Conclusion

We have presented experiments showing that recovering the motion of line-ends depends on their immediate surround, thus revealing a context effect in a direction discrimination task that results in lengthened response times and/or increased error rates. We propose a simple model according to which these effects are accounted for by a cooperative-competitive mechanism that involves long-range facilitation and surround suppression between collinear contours. This mechanism appears to be modulated after an uptake of Lorazepam, presumably by altering the balance between excitation and inhibition.

Acknowledgments

The pharmacological studies were financed by INSERM and by the University of Strasbourg. We thank Dr. Marie Welsch for the medical examination of the healthy volunteers. Supported by A.C.I. “Neurosciences Intégratives et Computationnelles” to J.L.

Appendix A

We here detail the implementation of the model used to generate Fig. 7. The S (resp I) cells represent the population of all end-stopped (resp. end-facilitated) cells that are sensitive to the motion of a segment stimulus (inner or outer line-end) during its trajectory. The temporal evolution of the populations S and I that are sensitive to a segment k are given by (Wilson & Cowan, 1972):

$$\tau \frac{dI_k(t)}{dt} = -I_k(t) + \beta_i [h_k^i(t) - T_i]_+ \quad (1)$$

$$\tau \frac{dS_k(t)}{dt} = -S_k(t) + \beta_s [h_k^s(t) - T_s]_+ \quad (2)$$

where τ is the integration time-constant for these populations, β_α is the gain of population $\alpha = s, i$. T_α denotes the activation threshold and $[\]_+$ denotes rectification. $h_\alpha^k(t)$ represents the input signals received by population

α which can be decomposed as follows. First, both I and S populations receive feedforward inputs: these are described by $F(t)$ and $\delta F(t)$ respectively. Because at each moment in the stimulus trajectory, the same number of motion-selective end-stopped cells are active, the input to the whole population of S cells can be considered as being constant in time. Second, I cells receive local inhibitory synapses from S cells (competition) with efficacy w_{is} , and long-range facilitatory connections from other I cells (collinear facilitation) with efficacy w_{ii} . Finally, S cells receive inhibitory synapses from surround I cells (end-stopping) with efficacy w_{si} . This long-range inhibition could be mediated disynaptically by long-range excitatory projections targeting inhibitory neurons (Hirsch & Gilbert, 1991). Note that this competitive connectivity scheme is very similar to that used by Liden and Pack (1999). We thus have, in the general case:

$$h_k^i(t) = F_k - w_{is}S_k(t) + \sum_{j \neq k} w_{ii}I_j(t) \quad (3)$$

$$h_k^s(t) = \delta F_k - \sum_{j \neq k} w_{si}I_j(t) \quad (4)$$

In our simulations, the inputs signals to the S and I populations sensitive to the two inner line-ends of the two segments (denoted k and j) are simply given by:

$$\begin{aligned} h_k^i(t) &= F_k - w_{is}S_k + w_{ii}I_j(t), \\ h_k^s(t) &= \delta F_k - w_{si}I_j(t) \end{aligned} \quad (5)$$

while the inputs to the S and I populations sensitive to the outer line-ends correspond to the situation with no surround interactions:

$$h_k^i(t) = F_k; \quad h_k^s(t) = \delta F_k \quad (6)$$

The parameters used are: $\beta_s = \beta_i = 3$; $\tau = 10$ ms; $T_s = T_i = 4$; $w_{ii} = 0.15$; $w_{si} = 0.2$; $w_{is} = 0.15$; $\delta = 1.5$. We suppose that the uptake of Lorazepam induces a 20% decrease in the amplitude of feed-forward inputs (non-specific inhibition), and a 50% increase in the amplitude of inhibitory synapses in the circuit. Only the cells that respond to the line-ends and that are optimally activated by the stimulus were explicitly modelled.

The activity of the decision cell (which would signal for e.g. that motion is clockwise) corresponds to a simple “accumulator of evidence”, integrating the activities of S cells that signal a motion of line-ends that is consistent with the decision to be made. It is modelled as a “leaky integrator”:

$$\tau_d \frac{dD(t)}{dt} = -D(t) + w_d \langle S_k(t) \rangle \quad (7)$$

where $\langle \ \rangle$ denotes the average across the population of S cells at each time step. This theoretical unit is character-

ized by a very long time constant: $\tau_d = 850$ ms; $w_d = 1.5$. The decision is made when the decision unit reaches a given threshold (here: $D(t) = 25$ spk/s).

This corresponds to an ideal situation of perfect accuracy with unlimited processing time. This model could be extended to address more precisely the speed/accuracy trade-off. This could be done simply by considering that the activity of the decision unit represents a degree of certainty in the response to be made. At threshold, the certainty is 100%, and there are no errors. When the response decreases below threshold (e.g. 75% of threshold), the certainty decreases (to, for example, 75%) and the number of errors increase (to, for e.g. 25%). More sophisticated implementations of such a decision stage can be found in Usher and McClelland (2001).

Note that although we assume for clarity that the detection of the relevant line-ends and the extraction of the direction of movement are implemented within the same circuit, we do not exclude that this process occurs along different stages, within V1 and/or MT.

References

- Anderson, J. S., Lampl, I., Gillespie, D. C., & Ferster, D. (2001). Membrane potential and conductance changes underlying length tuning of cells in cat primary visual cortex. *Journal of Neuroscience*, 21(6), 2104–2112.
- Beaudot, W. H., & Mullen, K. T. (2003). How long range is contour integration in human color vision. *Visual Neuroscience*, 20, 51–64.
- Biederman, I. (1987). Recognition by components: A theory of human image understanding. *Psychological Review*, 94, 115–147.
- Boucart, M., Delord, S., & Giersch, A. (1994). The computation of contour information in complex objects. *Perception*, 23(4), 399–409.
- Braun, J. (1999). On the detection of salient contours. *Spatial Vision*, 12(2), 211–225.
- Bringuier, V., Chavane, F., Glaeser, L., & Frégnac, Y. (1998). Horizontal propagation of visual activity revealed in the synaptic integration field of area 17 neurons. *Science*, 283, 695–699.
- Castet, E., & Wuerger, S. (1997). Perception of moving lines: interactions between local perpendicular signals and 2D motion signals. *Vision Research*, 37(6), 705–720.
- De Angelis, G. C., Freeman, R. D., & Ohzawa, I. (1994). Length and width tuning of neurons in the cat's primary visual cortex. *Journal of Neurophysiology*, 71(1), 347–374.
- Dobbins, A., Zucker, S. W., & Cynader, M. S. (1987). Endstopped neurons in the visual cortex as a substrate for calculating curvature. *Nature*, 329(October), 438–441.
- Eriksen, C. W., & Yeh, Y. Y. (1985). Allocation of attention in the visual field. *Journal of Experimental Psychology—Human Perception and Performance*, 11(5), 583–597.
- Field, D. J., Hayes, A., & Hess, R. F. (1993). Contour integration by the human visual system: Evidence for a local “association field”. *Vision Research*, 33, 173–193.
- Giersch, A. (1999). A new pharmacological tool to investigate integration processes. *Visual Cognition*, 6, 267–297.
- Giersch, A. (2001). The effects of lorazepam on visual integration processes: how useful for neuroscientists? *Visual Cognition*, 8, 549–563.
- Giersch, A., Boucart, M., & Danion, J. M. (1997). Lorazepam, a benzodiazepine, induces atypical distractor effects with compound stimuli: A role for line-ends in the processing of compound letters. *Visual Cognition*, 4, 337–372.
- Giersch, A., & Lorenceau, J. (1999). Effects of a benzodiazepine, Lorazepam, on motion integration and segmentation: an effect on the processing of line-ends? *Vision Research*, 39(11), 2017–2025.
- Gilbert, C. D., Das, A., Ito, M., Kapadia, M., & Westheimer, G. (1996). Spatial integration and cortical dynamics. *Proceedings of the National Academy of Sciences of the United States of America*, 93(2), 615–622.
- Gilbert, C. D., & Wiesel, T. (1989). Columnar specificity of intrinsic horizontal and cortico-cortical connections in cat visual cortex. *Journal of Neuroscience*, 9(7), 2432–2442.
- Grossberg, S., & Raizada, R. D. (2000). Contrast-sensitive perceptual grouping and object-based attention in the laminar circuits of primary visual cortex. *Vision Research*, 40(10–12), 1413–1432.
- Hess, R. F., Hayes, A., & Field, D. J. (2003). Contour integration and cortical processing. *Journal of Physiology (Paris)*, 97, 105–119.
- Hirsch, J. A., & Gilbert, C. D. (1991). Synaptic physiology of horizontal connections in the cat's visual cortex. *Journal of Neuroscience*, 11(6), 1800–1809.
- Hubel, D., & Wiesel, T. (1968). Receptive fields and functional architecture of the monkey striate cortex. *Journal of Physiology*, 195, 215–243.
- Hupé, J. M., James, A. C., Girard, P., & Bullier, J. (2001). Response modulations by static texture surround in area V1 of the macaque monkey do not depend on feedback connections from V2. *Journal of Neurophysiology*, 85(1), 146–163.
- Hupé, J. M., James, A. C., Payne, B. R., Lomber, S. G., Girard, P., & Bullier, J. (1998). Cortical feedback improves discrimination between figure and background by V1, V2 and V3 neurons. *Nature*, 394(6695), 784–787.
- Jones, H. E., Grieve, K. L., Wang, W., & Sillito, A. M. (2001). Surround suppression in primate V1. *Journal of Neurophysiology*, 86(4), 2011–2028.
- Julesz, B. (1981). Textons, the elements of texture perception and their interactions. *Nature*, 290, 91–97.
- Kanizsa, G. (1976). Subjective contours. *Scientific American*, 234(4), 48–52.
- Kapadia, M. K., Ito, M., Gilbert, C., & Westheimer, G. (1995). Improvement in visual sensitivity by changes in local context: parallel studies in human observers and in V1 of alert Monkeys. *Neuron*, 15, 843–856.
- Kapadia, M. K., Westheimer, G., & Gilbert, C. D. (2000). Spatial distribution of contextual interactions in primary visual cortex and in visual perception. *Journal of Neurophysiology*, 84(4), 2048–2062.
- Knierim, J. J., & Van Essen, J. C. (1992). Neuronal responses to static texture patterns in area V1 of the alert macaque monkey. *Journal of Neurophysiology*, 67, 961–980.
- Koffka, K. (1935). *Principles of Gestalt Psychology*. New York: Harcourt Brace.
- Kovacs, I., & Julesz, B. (1993). A closed curve is much more than an incomplete one: Effect of closure in figure-ground segmentation. *Proceedings of the National Academy of Sciences of the United States of America*, 90, 7495–7497.
- Lamme, V. A., Van Dijk, B. W., & Spekreijse, H. (1994). Organization of contour from motion processing in primate visual cortex. *Vision Research*, 34(6), 721–735.
- Lamouret, I., Lorenceau, J., & Droulez, J. (1996). A computational account of the perceived direction and speed of moving tilted lines. *Investigative Ophthalmology and Visual Science Supplement*, 37(3), 2365.
- Li, C., & Li, W. (1994). Extensive integration field beyond the classical receptive field of cat's striate cortical neurons: classification and tuning properties. *Vision Research*, 34, 2337–2355.
- Li, Z. (1999). Visual segmentation by contextual influences via intracortical interactions in primary visual cortex. *Network: Computation in Neural Systems*, 10(2), 187–212.

- Liden, L., & Pack, C. (1999). The role of terminators and occlusion cues in motion integration and segmentation: a neural network model. *Vision Research*, 39(19), 3301–3320.
- Lorenceau, J., & Shiffrar, M. (1992). The influence of terminators of motion integration across space. *Vision Research*, 32(2), 263–273.
- Lorenceau, J., Shiffrar, M., Walls, N., & Castet, E. (1993). Different motion sensitive units are involved in recovering the direction of moving lines. *Vision Research*, 9, 1207–1217.
- Majaj, N., Smith, M. A., Kohn, A., Bair, W., & Movshon, J. A. (2002). A role for terminators in motion processing by macaque MT neurons? *Journal of Vision*, 2(7), 415a, <http://journalofvision.org/2/7/415/>, DOI 10.1167/2.7.415.
- Masson, G. S., Mestre, D. R., Martineau, F., Soubrouillard, C., Brefel, C., Rascol, O., & Blin, O. (2000). Lorazepam-induced modifications of saccadic and smooth-pursuit eye movements in humans: attentional and motor factors. *Behavioral Brain Research*, 108(2), 169–180.
- Masson, G. S., Rybarczyk, Y., Castet, E., & Mestre, D. R. (2000). Temporal dynamics of motion integration for the initiation of tracking eye movements at ultra-short latencies. *Visual Neuroscience*, 17(5), 753–767.
- McGuire, B., Gilbert, C., Rivlin, P., & Wiesel, T. (1991). Target of horizontal connections in macaque primary visual cortex. *Journal of Comparative Neurology*, 305, 370–392.
- Mingolla, E., Todd, J. T., & Norman, J. F. (1992). The perception of globally coherent motion. *Vision Research*, 32, 1015–1031.
- Mohler, H., Benke, D., Benson, J., Lüscher, B., & Fritschy, J. M. (1995). GABA_A-receptor subtypes in vivo: cellular localization, pharmacology and regulation. In G. Biggio, E. Sanna, & E. Costa (Eds.), *GABA_A receptors and anxiety: from neurobiology to treatment* (pp. 41–56). New York: Raven Press.
- Nakayama, K., & Silverman, G. H. (1988). The aperture problem I: Perception of non-rigidity and motion direction in translating sinusoidal lines. *Vision Research*, 28, 739–746.
- Nakayama, K., & Shimojo, S. (1990). Da Vinci stereopsis: depth and subjective occluding contours from unpaired image points. *Vision Research*, 30, 1811–1825.
- Orban, G. A., Kato, H., & Bishop, P. O. (1979). Dimensions and properties of End-zone inhibitory areas in receptive fields of hypercomplex cells in cat striate cortex. *Journal of Physiology*, 42, 833–850.
- Pack, C. C., & Born, R. T. (2001). Temporal dynamics of a neural solution to the aperture problem in visual area MT of macaque brain. *Nature*, 22:409(6823), 905–908.
- Pack, C. C., Livingstone, M. S., Duffy, K. R., & Born, R. T. (2003). End-stopping and the aperture problem: Two-dimensional motion signals in macaque V1. *Neuron*, 39, 671–680.
- Pettet, M. W., McKee, S. P., & Grzywacz, N. M. (1998). Constraints on long range interactions mediating contour detection. *Vision Research*, 6, 865–879.
- Polat, U., & Sagi, D. (1994). The architecture of perceptual spatial interactions. *Vision Research*, 34, 73–78.
- Posner, M. I., Snyder, C. R., & Davidson, B. J. (1980). Attention and the detection of signals. *Journal of Experimental Psychology*, 109(2), 160–174.
- Rubin, N., & Hochstein, S. (1993). Isolating the effect of one-dimensional motion signals on the perceived direction of moving two-dimensional objects. *Vision Research*, 10, 1385–1396.
- Sceniak, M. P., Ringach, D. L., Hawken, M. J., & Shapley, R. (1999). Contrast's effect on spatial summation by macaque V1 neurons. *Nature Neuroscience*, 2(8), 733–739.
- Scott-Brown, K. C., & Heeley, D. W. (2001). The effect of the spatial arrangement of target lines on perceived speed. *Vision Research*, 41(13), 1669–1682.
- Seriès, P. S., Lorenceau, J., & Frégnac, Y. (2004). The silent surround of V1 receptive fields: theory and experiments. *Journal of Physiology (Paris)*, 97(4–6), 453–474.
- Shadlen, M. N., & Newsome, W. T. (2001). Neural basis of a perceptual decision in the parietal cortex (area LIP) of the rhesus monkey. *Journal of Neurophysiology*, 86(4), 1916–1936.
- Shimojo, S., Silverman, G., & Nakayama, K. (1989). Occlusion and the solution to the aperture problem for motion. *Vision Research*, 29, 619–626.
- Sillito, A. M., & Versiani, V. (1977). The contribution of excitatory and inhibitory inputs to the length preference of hypercomplex cells in layers II and III of the cat's striate cortex. *Journal of Physiology (London)*, 273, 775–790.
- Sincich, L. C., & Blasdel, G. G. (2001). Oriented axon projections in primary visual cortex of the monkey. *Journal of Neuroscience*, 15:21(12), 4416–4426.
- Smith, G. B., & Olsen, R. W. (1995). Functional domains of GABA_A receptors. *Trends in Pharmacological Sciences*, 16, 162–168.
- Somers, D. C., Todorov, E. V., Siapas, A. G., Toth, L. J., Kim, D. S., & Sur, M. (1998). A local circuit approach to understanding integration of long-range inputs in primary visual cortex. *Cerebral Cortex*, 8(3), 204–217.
- Speeg-Schatz, C., Giersch, A., Boucart, M., Gottenkiene, S., Tondre, M., Kauffmann-Muller, F., & Danion, J. M. (2001). Effects of lorazepam on vision and oculomotor balance. *Binocular Vision & Strabismus Quarterly*, 16(2), 99–104.
- Stettler, D. D., Das, A., Bennett, J., & Gilbert, C. D. (2002). Lateral connectivity and contextual interactions in macaque primary visual cortex. *Neuron*, 36(4), 739–750.
- Usher, M., & McClelland, J. L. (2001). The time course of perceptual choice: the leaky, competing accumulator model. *Psychological Review*, 108(3), 550–592.
- Van Wezel, R. J. A., & van der Smagt, M. J. (2003). Motion processing: how low can you go? *Current Biology*, 13, 840–842.
- Walker, G., Ohzawa, I., & Freeman, R. (2000). Suppression outside the classical receptive field. *Visual Neuroscience*, 17, 369–379.
- Wilson, H., & Cowan, J. (1972). Excitatory and inhibitory interactions in localized populations of model neurons. *Biophysical Journal*, 12, 1–24.
- Yu, C., & Essock, E. A. (1996). Spatial scaling of end-stopped receptive fields: differences in neural bases of end-zones, flanks and centers. *Vision Research*, 36(19), 3129–3139.
- Yu, C., & Levi, D. M. (1998a). Rectification non-linearity in cortical end-stopped receptive fields. *Vision Research*, 38(22), 3517–3530.
- Yu, C., & Levi, D. M. (1998b). Spatial-frequency and orientation tuning in psychophysical end-stopping. *Visual Neuroscience*, 5(4), 585–595.
- Yu, C., & Levi, D. M. (1999). The time course of psychophysical end-stopping. *Vision Research*, 39(12), 2063–2073.
- Zucker, S. W., & Davis, S. (1988). Points and end points: a size/spacing constraint for dot grouping. *Perception*, 17(2), 229–247.