



# THE UNIVERSITY *of* EDINBURGH

## Edinburgh Research Explorer

### **Application of Real-Time Optimization Methods to Energy Systems in the Presence of Uncertainties and Disturbances**

**Citation for published version:**

Francois, G, Costello, S & Bonvin, D 2015, 'Application of Real-Time Optimization Methods to Energy Systems in the Presence of Uncertainties and Disturbances' TMC Academic Journal, vol. 9, no. 2.

**Link:**

[Link to publication record in Edinburgh Research Explorer](#)

**Document Version:**

Peer reviewed version

**Published In:**

TMC Academic Journal

**General rights**

Copyright for the publications made accessible via the Edinburgh Research Explorer is retained by the author(s) and / or other copyright owners and it is a condition of accessing these publications that users recognise and abide by the legal requirements associated with these rights.

**Take down policy**

The University of Edinburgh has made every reasonable effort to ensure that Edinburgh Research Explorer content complies with UK legislation. If you believe that the public display of this file breaches copyright please contact [openaccess@ed.ac.uk](mailto:openaccess@ed.ac.uk) providing details, and we will remove access to the work immediately and investigate your claim.



# Application of Real-Time Optimization Methods to Energy Systems in the Presence of Uncertainties and Disturbances

**Grégory François**

Laboratoire d'Automatique, Ecole Polytechnique Fédérale de Lausanne ;  
University of Applied Sciences and Arts, Western Switzerland, Delémont,  
Switzerland

**Sean Costello**

Laboratoire d'Automatique, Ecole Polytechnique Fédérale de Lausanne,  
Switzerland

**Dominique Bonvin**

Laboratoire d'Automatique, Ecole Polytechnique Fédérale de Lausanne,  
Switzerland

\*Corresponding author: [gregory.francois@hes-so.ch](mailto:gregory.francois@hes-so.ch)

## Abstract

*In practice, the quest for the optimal operation of energy systems is complicated by the presence of operating constraints, which includes the need to produce the power required by the user, and by the need to account for uncertainty. The latter concept incorporates the potential inaccuracies of the models at hand but also degradation effects or unexpected changes, such as, e.g. random load changes or variations of the availability of the energy source for renewable energy systems. Since these changes affect the optimal values of the operating conditions, online adaptation is required to ensure that the system is always operated optimally. This typically implies the online solving of an optimization problem. Unfortunately, the applicability and the performances of most model-based optimization methods rely on the quality of the available model of the system under investigation. On the other hand, Real-time optimization (RTO) methods use the available online measurements in the optimization framework and are, thus, capable of bringing the desired self-optimizing control reaction. In this article, we show the benefits of using several RTO methods (co-) developed by the authors to energy systems through the successful application of (i) "Real-Time Optimization via Modifier Adaptation" to an experimental solid oxide fuel cells (SOFC) stack, of (ii) the recently released "SCFO-solver" (where SCFO stands for "Sufficient Conditions of Feasibility and Optimality") to an industrial SOFC stack, and of (iii) Dynamic RTO to a simulated tethered kite for renewable power production. It is shown how such problems can be formulated and solved, and significant improvements of the performances of the three aforementioned energy systems are illustrated.*

**Key Words:** real-time optimization, energy systems, RTO, renewable power production.

## 1 INTRODUCTION

In a world of increasing competition and emerging energy crisis, operating energy systems optimally is a must. This is particularly true for the most innovative devices or for renewable energy systems, since most need to prove that the higher investment costs can be compensated by higher operating performances. Standard approaches for determining the optimal operating conditions consist of solving a model-based optimization problem, for which a model of the system must be available. Many

schemes are available in the literature that can provide the optimal values of the degrees of freedom for a given model under given experimental conditions. In practice however, the available models for industrial energy systems are often inaccurate for two main reasons:

1. Model parameters are generally computed to a confidence level,
2. Some phenomena can be unknown or neglected.

Also, even a structurally correct model, with accurate parameters may become incorrect with time, as the real system it mimics faces real-time disturbances, degradation, and many other unexpected (and thus un-modeled) events/phenomena. Thus, solving a model-based optimization problem is not sufficient for real-life applications and leads to sub-optimal performance, or worse, to potential violations of the operating constraints.

Hence, there is clearly a need for methods that are capable of rejecting the effect of all the aforementioned sources of uncertainty, while enforcing the satisfaction of operating constraints. This is exactly the scope of Real-Time Optimization (RTO) methods. RTO was first applied in the chemical industry more than 30 years ago. This is because, until recently, optimization techniques were only applicable to slow processes due to the heavy computational load. This is no longer the case and, generally speaking, optimization methods are now considered as viable technologies (Boyd & Vandenberghe, 2004 ; Rotava & Zanin, 2005). On the other hand, RTO has been rarely applied to industrial energy systems despite its undeniable potential.

Optimization of energy systems under uncertainty is, however, quite an active research field. This led to a massive number of publications that were reviewed recently (Zeng, Cai, Huang & Dai, 2011). In (Zeng et al., 2011) the authors distinguish classical model-based methods, for which uncertainty is discarded, from "Inexact Optimization Modeling", that is, Optimization with inexact models. They mainly list methods from the field of artificial intelligence (fuzzy mathematical programming), stochastic approaches and interval analysis. The common point of these three families of methods is their conservative nature. By focusing on the risk of violating constraints, many researchers choose robust approaches whereby uncertainty is considered typically by "worst-case" design or in the expected sense. This leads to the introduction of safety margins, and thus, of conservatism. When measurements are used, i.e. with RTO methods, this conservatism can be massively reduced, if not fully removed.

The benefits of using RTO for energy systems have been discussed very recently (Serralunga, Mussati & Aguirre, 2013). Their five main arguments for a wider use of RTO methods for heat and power systems are the following:

- (i) RTO can handle changes in steam demand, price of electric power (potentially fast and frequent according to grid demands in deregulated markets),
- (ii) It can counteract the effect of changes in boiler and turbine efficiencies,
- (iii) The fast dynamics of most energy systems allow the use of steady state models,
- (iv) The resulting steady-state optimization problems can be solved with a period of the order of minutes instead of the typical hours.
- (v) The authors claim that the online use of steady state RTO methods can avoid the use of an advanced control layer with, e.g., model-predictive control.

From the authors' viewpoint, the four first aforementioned reasons are valid. On the other hand, for the most innovative energy systems, the presence of an appropriate advanced control scheme can be compulsory. This is the case for energy systems for

which optimization at steady state is insufficient to guarantee the stability of the system during the transient phase to steady state, for instance for fast and unstable dynamical systems. Meanwhile, another good reason to apply RTO to energy systems lies in the capacity of some of the most recent RTO techniques to reject not only the effect of parametric uncertainty (such as (ii)) and of disturbances (such as (i)), but also the effect of structural plant-model mismatch.

Probably the most intuitive and popular family of techniques in the industry are the two-stage (Marlin & Hrymak, 1997) (aka “two-step”) approaches (RTO-TS). RTO-TS uses the difference between the output measurements and the corresponding model predictions to adapt the model parameters, with the updated model being used to repeat the optimization. Although appealing, it has been shown that these techniques are not capable of rejecting the effect of *structural plant-model mismatch* (Marchetti, Chachuat, & Bonvin, 2009), unless very stringent model adequacy conditions are met (Forbes & Marlin, 1996). Recently, it has been proposed to update the model differently. Instead of adjusting the model parameters iteratively, measurement-based correction terms are iteratively added to the cost and constraint functions of the optimization problem. The technique, labeled RTO via modifier adaptation (RTO-MA), forces the modeled cost and constraints to match the plant values (Marchetti et al. 2009; Gao & Engell, 2005). The main advantage of RTO-MA compared to the RTO-TS lies in its ability to converge to the true plant optimum, even in the presence of structural plant-model mismatch (Marchetti et al. 2009). Both families are referred to as explicit methods as they rely on the repeated solving of a model-based optimization problem, but they differ on how measurements are used to reject the effect of uncertainty and model mismatch. In contrast, implicit methods, such as extremum-seeking control (Ariyur & Krstic, 2003; Guay, Moshksar & Dochain, 2014), self-optimizing control (Skogestad, 2000) and NCO tracking (François, Srinivasan, & Bonvin, 2005), propose to adjust the degrees of freedom on-line in a control-inspired manner, by, e.g., forcing the necessary conditions of optimality of the real system to be satisfied.

The goal of this article is to further illustrate the potential benefits of RTO methods for the optimization of energy systems under changing conditions, parametric uncertainty and disturbances, but also in the case of structural plant-model mismatch. Since, practically speaking, solving an optimization problem for uncertain or badly modeled processes might seem to be obscure, we first show how these problems are formulated in the general setting. Then, we show how this can be done in the context of energy systems in an application-oriented manner. Three methods (co-)developed by the authors and their coworkers as well as three examples are considered: (i) RTO-MA (Marchetti et al., 2009) and (ii) the recently released open-source “SCFO-solver” (Bunin, François & Bonvin, 2013), and (iii) dynamic RTO (Costello, François & Bonvin, 2013). Successful application of RTO-MA is reported for the optimization of a 6-cell experimental SOFC stack (Bunin, Wuillemin, François, Nakajo, Tsikonis & Bonvin, 2012), and new results are given for the successful application of the SCFO solver to a 2-cell industrial SOFC stack. Also, application of dynamic RTO to a simulated tethered kite for power production is discussed (Costello et al. 2013), with ongoing experimental application. The latter example underlines that RTO for fast and unstable dynamical systems must be combined with an advanced control scheme. The latter enforces online stability while RTO, performed at a lower frequency, leads to a progressive improvement of the overall performance of the system. One of the messages of this contribution is thus to show, on the basis of the authors’ own experience, that the gap between mathematically sound optimization methods and real-life applications to energy systems is not as big as one may think.

The paper is organized as follows. After some preliminaries in Section 2, RTO is discussed in Section 3. Section 4 presents the case studies and the tailored formulation of the RTO methods. The corresponding results are presented in Section 5 and discussed in Section 6, while Section 7 concludes the paper.

## 2 PRELIMINARIES

The problem of optimizing the performance of a given energy system (hereafter referred to as “the plant”) can be formulated mathematically as follows:

$$\begin{aligned} \mathbf{u}_p^* &:= \arg \min_{\mathbf{u}} \phi_p(\mathbf{u}) \\ \text{s.t. } \mathbf{G}_p(\mathbf{u}) &\leq \mathbf{0} \end{aligned} \quad (1)$$

, where  $\phi_p$  is the plant cost (i.e. the performance indicator),  $\mathbf{G}_p$  the  $n_g$ -dimensional vector of plant constraints and  $\mathbf{u}$  the  $m$ -dimensional vector of constant inputs (the so-called “degrees of freedom”).

In practice, the functions  $\phi_p$  and  $\mathbf{G}_p$  are measured but their mathematical expression is generally unknown. However, they are generally estimated with a process model, and Problem (1) is replaced by the following model-based problem:

$$\begin{aligned} \mathbf{u}^* &:= \arg \min_{\mathbf{u}} \phi(\mathbf{u}, \theta) \\ \text{s.t. } \mathbf{G}(\mathbf{u}, \theta) &\leq \mathbf{0} \end{aligned} \quad (2)$$

, where  $\phi$  is the model cost,  $\theta$  the  $n_\theta$ -dimensional vector of model parameters and  $\mathbf{G}$  the  $n_g$ -dimensional vector of model constraints. The necessary conditions of optimality (“the NCOs”) of the model read (Bazarrá, Serali & Shetty, 1993):

$$\begin{aligned} \mathbf{G}(\mathbf{u}^*, \theta) \leq \mathbf{0}, \quad \mathbf{v}^* \geq \mathbf{0}, \quad (\mathbf{v}^*)^T \mathbf{G}(\mathbf{u}^*, \theta) &= \mathbf{0} \\ \nabla \Phi(\mathbf{u}^*, \theta) + (\mathbf{v}^*)^T \nabla \mathbf{G}(\mathbf{u}^*, \theta) &= \mathbf{0} \end{aligned} \quad (3)$$

, where  $\mathbf{v}$  is the vector of Lagrange multipliers for the model. This is where the discrepancies between the model and the plant become problematic. To be optimal for the plant, the optimal inputs  $\mathbf{u}^*$  must satisfy the NCO of the plant.

In the ideal case, the cost and constraint functions of Problems (1) and (2) are exactly the same and solving Problem (3) is equivalent to solving Problem (1). In practice, however, these functions often differ, because of (i) the value of the model parameters, which can be inaccurately estimated, (ii) the mathematical expressions of the functions, which may differ because of unknown or neglected phenomena and (iii) disturbances, which can lead to the apparition of new unknown phenomena and/or may change the values of key parameters. Hence, the NCOs of Problems (1) and (2) are also different (that is Equation (3) and Equation (4), respectively) and, thus, the solution of (2) is not necessarily a solution of (1).

$$\begin{aligned} \mathbf{G}_p(\mathbf{u}_p^*) \leq \mathbf{0}, \quad \mathbf{v}_p^* \geq \mathbf{0}, \quad (\mathbf{v}_p^*)^T \mathbf{G}_p(\mathbf{u}_p^*) &= \mathbf{0} \\ \nabla \Phi_p(\mathbf{u}_p^*) + (\mathbf{v}_p^*)^T \nabla \mathbf{G}_p(\mathbf{u}_p^*) &= \mathbf{0} \end{aligned} \quad (4)$$

## 3 REAL-TIME OPTIMIZATION

### Classification of RTO Methods

RTO methods aim to reject the effect of uncertainty on optimal performance. For this purpose, RTO methods rely on the use of measurements and appropriate feedback. If the cost function and the constraints of the plant are measured (which is typically the case) it is readily seen, whenever it occurs, that their values differ from their model predictions at any given  $\mathbf{u}$ . This difference between the predictions and the corresponding measurements is indeed the common driving force of most RTO methods.

The way RTO methods use measurement is depicted in Figure 1 and is put in perspective with the standard framework of process optimization.

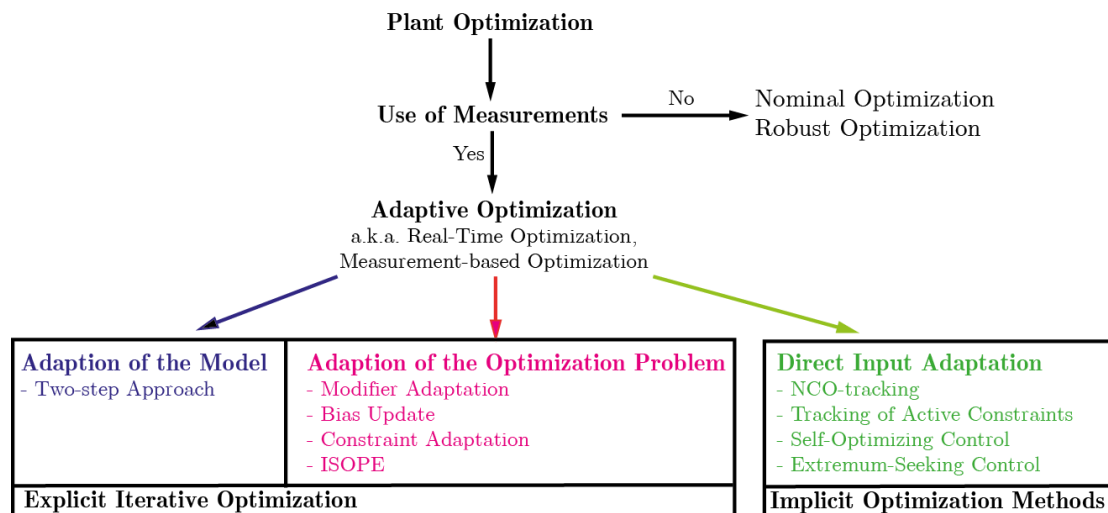

**Figure 1. Classification of Several RTO Methods and of their Philosophies**

As indicated by Figure 1 there are three main ways of using the available process measurements:

1. Measurements can be used to refine the model. By model refinement, it has to be understood that the mathematical expressions of the functions  $\phi$  and  $\mathbf{G}$  are updated in between consecutive optimization iterations. This adaptation is performed by updating the model parameters  $\theta$ . Two problems are iteratively solved: the identification problem and the optimization problem (3), for which  $\phi$  and  $\mathbf{G}$  are modified, *at each iteration*.
2. Measurements can also be used to directly modify the optimization problem. With these methods, the driving force is the determination of corrective terms that are directly added to the expressions of  $\phi$  and  $\mathbf{G}$  in formulation (3), which are kept unchanged. No parameter identification is performed, but a modified version of the optimization problem (3) is solved *at each iteration*.
3. The third class of methods proposes to use the driving force to directly modify the inputs  $\mathbf{u}$ , in a control-inspired manner. With these methods, the problem (3) is only solved once, for the initialization of  $\mathbf{u}$ . The main difficulty is to construct a control problem, which has the desired self-optimizing properties, i.e. which guarantees that the resolution of the control problem implicitly enforces the resolution of Problem (1).

### Selected RTO methods

In this section we discuss in more detail the three RTO methods, which are to be applied to the three energy systems in the subsequent sections. The main reason for choosing these three RTO methods is their proven ability to converge to the true plant optimal inputs in the presence of plant-model mismatch, that is, for cases where the other RTO methods fail.

**Real-Time Optimization via Modifier Adaptation (RTO-MA)**

RTO-MA belongs to the second column of RTO methods depicted in Figure 1. Measurements, or in better words, deviations between predicted and measured quantities are used to modify the model-based problem formulation by adding affine-in-input correction terms to  $\phi$  and  $\mathbf{G}$ .

With RTO-MA, a modified version of Problem (3) is solved repeatedly at steady state, until convergence to the plant optimum is reached. For example, at the  $k^{\text{th}}$  iteration, the following problem is solved:

$$\begin{aligned} \mathbf{u}_{k+1}^* &:= \underset{\mathbf{u}}{\operatorname{argmin}} \left( \phi_m(\mathbf{u}, \theta) := \phi(\mathbf{u}, \theta) + \Lambda_k^{\phi T} (\mathbf{u} - \mathbf{u}_k^*) \right) \\ \text{s.t. } \mathbf{G}_m &:= \mathbf{G}(\mathbf{u}, \theta) + \Lambda_k^{G T} (\mathbf{u} - \mathbf{u}_k^*) \leq \mathbf{0} \end{aligned} \quad (5)$$

where  $\mathbf{u}_{k+1}^*$  denotes the solution at iteration  $k$  that will be used at the next iteration. Optimization problem (3) is modified by the addition of a linear correction term to the cost and an affine correction term to the constraints, with the modifiers defined as follows  $\varepsilon_k := \mathbf{G}_p(\mathbf{u}_k^*) - \mathbf{G}(\mathbf{u}_k^*, \theta)$ ,  $\Lambda_k^{\phi} := \nabla \phi_p(\mathbf{u}_k^*) - \nabla \phi(\mathbf{u}_k^*, \theta)$  and  $\Lambda_k^G := \nabla \mathbf{G}_p(\mathbf{u}_k^*) - \nabla \mathbf{G}(\mathbf{u}_k^*, \theta)$ .

With RTO-MA, the so-called 1<sup>st</sup>-order modifications imply that the gradients of the modified model cost and constraints  $\phi_m$  and  $\mathbf{G}_m$  are corrected, although the parameters of the model  $\phi$  and  $\mathbf{G}$  are not modified. This is a major difference with RTO-TS, whereby the mathematical expression of the model is modified, by means of the update of the model parameters  $\theta$ . This identification is performed with the objective of minimizing the distance between the predicted and the measured values of  $\phi$  and  $\mathbf{G}$ , which ultimately leads to perfect fitting of the data collected. But nothing guarantees that the gradients of the modified functions  $\phi$  and  $\mathbf{G}$  will match the gradients of  $\phi_p$  and  $\mathbf{G}_p$ .

As seen from (3) and (4), the values of the predicted constraints have to match the values of the plant constraints to ensure feasibility. But since the second rows of the conditions (3) and (4) are 1<sup>st</sup>-order, the matching of the gradients is also required for enforcing the satisfaction of the sensitivity conditions. While RTO-TS cannot guarantee this latter point, RTO-MA is, by construction, capable of doing so provided the model exhibits adequacy conditions (Marchetti et al. 2009). In summary, the nicest feature of RTO-MA lies in that, upon convergence, (5) and (1) share the same NCO, that is, convergence to the plant optimum is possible despite the presence of uncertainty (Marchetti, 2009; Marchetti et al., 2009). Similar adequacy conditions also exist for RTO-TS (Forbes et al., 1996) but they are much more restrictive for RTO-MS than for RTO-MA. Furthermore, model adequacy conditions become trivially satisfied if convex approximations of the functions  $\phi$  and  $\mathbf{G}$  (Francois & Bonvin, 2013) are used. In addition recent work on gradient estimation techniques (Bunin, Francois & Bonvin, 2013; Francois, Srinivasan & Bonvin, 2012; Srinivasan, Francois & Bonvin, 2011) has compared or proposed methods that can be used for estimating the 1<sup>st</sup>-order modifier terms, denoted in this article by the Greek letter  $\Lambda$ .

**The SCFO-solver**

The SCFO-solver is a recent open-source solver (Bunin, Francois & Bonvin, 2013a) that implements the so-called “sufficient conditions for feasibility and optimality”

(SFCOs) (Bunin, Francois & Bonvin, 2014a). These conditions, given below, are sufficient conditions, which, when satisfied, ensure that a sequence of experiments converge to a local optimal solution of Problem (1), with the additional property that *each iterate is feasible*.

Equation (6) summarizes the key equations of the SCFOs, in the general case.

$$\begin{aligned}
 g_{p,j}(\mathbf{u}_k) + \sum_{i=1}^{n_u} \kappa_{p,ji} |u_{k+1,j} - u_{k,i}| & \quad \forall j = 1, \dots, n_{g,p} \\
 g_j(\mathbf{u}_k) & \leq \mathbf{0} \quad \forall j = 1, \dots, n_g \\
 \mathbf{u}^L & \leq \mathbf{u}_{k+1} \leq \mathbf{u}^U \\
 \nabla g_{p,j}(\mathbf{u}_k)^T (\mathbf{u}_{k+1} - \mathbf{u}_k) & < 0 \quad \forall j: g_{p,j}(\mathbf{u}_k) \approx \mathbf{0} \\
 \nabla g_j(\mathbf{u}_k)^T (\mathbf{u}_{k+1} - \mathbf{u}_k) & < 0 \quad \forall j: g_j(\mathbf{u}_k) \approx \mathbf{0} \\
 \nabla \phi_p(\mathbf{u}_k)^T (\mathbf{u}_{k+1} - \mathbf{u}_k) & < 0 \\
 \nabla \phi_p(\mathbf{u}_k)^T (\mathbf{u}_{k+1} - \mathbf{u}_k) + \frac{1}{2} \sum_{i=1}^{n_u} \sum_{i_2=1}^{n_u} M_{\phi_{i_1, i_2}} |u_{k+1, i_1} - u_{k, i_1}| |u_{k+1, i_2} - u_{k, i_2}| & < 0
 \end{aligned} \tag{6}$$

In (6) the SCFOs for the real process are summarized. Two kinds of constraints are considered :

1.  $n_{g, p}$  constraints  $g$  with the subscript “p” to account for the uncertain constraints
2.  $n_g$  constraints  $g$  without the subscript “p” to account for the certain constraints

Note that these conditions are not implementable per se, as they are mainly of mathematical nature. They rely on the assumption that all functions are  $C^2$  and Lipschitz-continuous (Korn & Korn, 2000), with estimates of the Lipschitz constants ( $\kappa$ ) and of a quadratic upper bound on the cost (Bunin, Francois & Bonvin, 2014b), here denoted  $M_\phi$ , available. The proof that these conditions are indeed sufficient is very involved and requires several intermediate lemmas and theorem. The presentation or the discussion of these results is beyond the scope of this article and the interested reader is kindly invited to read (Bunin & al., 2014a). Note, however, that the SCFOs are presented here in an unpublished, very compact formulation.

Although very technical, these conditions can still be interpreted.

- The three first equations enforce feasibility at the subsequent iterate: since the global maximal amplitude of the variations of all the process constraints is supposed to be known (through Lipschitz constants), a simple reverse engineering analysis allows to determine the maximum distance between the current and the future set of operating conditions, which ensures that no constraint will be violated. For example, if there is a constraint of temperature (say  $T(\mathbf{u}) < 373\text{K}$ ), for all  $\mathbf{u}$ , if the current temperature is  $T(\mathbf{u}_k) = 353\text{K}$ , and if the Lipschitz constant of the function  $T(\mathbf{u})$  is equal to 4, this means that forcing the subsequent iterate  $\mathbf{u}_{k+1}$  to lie in a ball of radius 5 around  $\mathbf{u}_k$ , guarantees feasibility at the next iteration, since the fact that the Lipschitz constant is 4 implies that  $T(\mathbf{u}_{k+1}) \leq T(\mathbf{u}_k) + 4\|\mathbf{u}_{k+1} - \mathbf{u}_k\|$ , that is  $T(\mathbf{u}_{k+1}) \leq 353 + 4 * 5 = 373\text{K}$
- The two last equations ensure that the plant cost will be strictly better at the subsequent iteration (See (Bunin et al., 2014a) for the mathematical details), unless convergence to the plant optimum is achieved.



- Unfortunately, going in the correct direction with feasible iterates is not sufficient as infinitely small steps have to be avoided. This is enforced by the 4<sup>th</sup> and the 5<sup>th</sup> equations of Equation (6), the so-called “projection conditions”, which guarantee that the next iterate lies strictly in the set of local descent directions of all constraints, and that each move is not infinitely small.
- The 7<sup>th</sup> condition of Equation (6) guarantees that the decrease of the cost function is bigger than the global maximal possible increase of the cost function induced by the existence of a quadratic upper bound. Note that Lipschitz constants and quadratic upper bounds are shown to always exist for twice continuously differentiable functions (Bunin et al., 2014b).

As such, the SCFOs are not implementable. The aim of the solver is thus to formulate the SCFOs in an implementable way and, in turn, to allow either their stand-alone implementation, or their implementation in addition to the chosen RTO method. Without entering into the details, the SCFOs become implementable when the strict inequalities are relaxed by means of individual back-offs, backed-off broad inequalities replacing thus the original strict inequalities. The corresponding slack variables are indeed the tuning parameters of the solver, and it is shown in (Bunin et al., 2014a) that by asymptotically reducing the values of these variables, the user will converge in a finite number of iterates arbitrarily close to a local optimum of the *plant optimization problem* of Equation (1). Indeed, this solver can thus be seen itself as a stand-alone RTO method or, alternatively, as a framework for RTO methods. With the latter, the set of operating conditions obtained with a given RTO solver will follow the modifications induced by the implementable version of (6), guaranteeing thus feasibility and cost improving iterates. The user can thus benefit from the power of the most recent model-based RTO algorithms (speed of convergence, low failure rates) while reducing the risks of constraint violations or of sub-optimality induced by the use of inaccurate models.

## 4 CASE STUDIES

### RTO-MA of an experimental SOFC stack

The first case study considers the optimization of the electrical efficiency of a Solid Oxide Fuel short-stack developed at EPFL for HTceramix – SOFCpower (Diethelm, Van Herle, Wuillemmin, Nakajo, Autissier & Molinelli, 2008; Wuillemmin, 2009).

A detailed description of this 6-cells experimental stack is given in (Bunin et al., 2012). A steady-state simplified model of this device is available (Marchetti, 2009). It is known that this tendency model is not very accurate for the prediction of the polarization curve, the cell potential, the temperature and the power produced.

The experimental setup has 3 degrees of freedom  $\mathbf{u} = [n_{O_2}, \dot{n}_{H_2}, I]^T$  (i.e., the manipulated inputs): the fluxes of Hydrogen  $\dot{n}_{H_2}$  and Oxygen  $n_{O_2}$  and the current intensity  $I$ , and three measured outputs: the power density  $p_{el,p}$ , the cell potential  $U_{cell,p}$  and the electrical efficiency  $\eta_p(\mathbf{u})$ .

The aim is to maximize the electrical efficiency  $\eta_p(\mathbf{u})$  while: (i) producing the (unknown and varying) power density asked by the user  $p_{el}^S$ , (ii) maintaining the cell potential above a lower bound of 0.75V, (iii) maintaining the fuel utilization  $v(\mathbf{u}) = \frac{N_{cells}I}{2\dot{n}_{H_2}F}$  below 0.75, and (iv) maintaining the air ratio  $\lambda_{air}(\mathbf{u}) = 2 \frac{n_{O_2}}{\dot{n}_{H_2}}$  between 4 and 7. Finally, the fluxes and the current intensity are bounded. The presence of the two constraints on the cell potential and the fuel utilization is justified as their satisfaction

is supposed to be the best way to increase the lifetime of the cell and to avoid fuel starvation.

This problem can be formulated as a plant optimization problem:

$$\begin{aligned}
 \max_{\mathbf{u}} \quad & \eta_p(\mathbf{u}) := \frac{U_{cell,p} N_{cells} p_{el,p}}{\dot{n}_{H_2} Q_L} \\
 \text{s.t.} \quad & p_{el,p}(\mathbf{u}) = p_{el}^S \\
 & U_{cell,p}(\mathbf{u}) \geq 0.75 V \\
 & v(\mathbf{u}) := \frac{N_{cells} I}{2 \dot{n}_{H_2} \mathcal{F}} \leq 0.75 \\
 & 4 \leq \lambda_{air}(\mathbf{u}) := 2 \frac{\dot{n}_{O_2}}{\dot{n}_{H_2}} \leq 7 \\
 & u_1 := \dot{n}_{O_2} \geq 3.14 \text{ ml} \cdot \text{min}^{-1} \cdot \text{cm}^{-2} \\
 & u_3 := I \leq 30 A
 \end{aligned} \tag{7}$$

, where  $Q_L$  denotes the lower heating value of the fuel.

Solving problem (7) requires the use of an appropriate RTO method because:

1. the available model (Marchetti, 2009) is a steady-state model, although the fuel cell stack is a dynamical system, with its temperature exhibiting the behavior of dynamical system with a settling time of about 30 minutes. Thus, there is plant-model mismatch, and parametric uncertainty.
2. the first equality constraint  $p_{el,p} = p_{el}^S$ , means that the power produced should match in real-time the required value. But in practice the value of  $p_{el}^S$  is not known in advance.
3. the cell potential is not known with certainty. It is indeed modeled on the basis an equivalent-circuit approach (Nakajo, Wuillemin, Van Herle & Favrat, 2009), but it is widely admitted that model predictions are not, by far, perfect.

Note that the fuel utilization and the air ratio depend only on the value of the inputs and of parameters, which are known with certainty (there is no uncertainty on the number of cells, on  $Q_L$  and on the Faraday constant). The subscript “p” is thus omitted for these two quantities.

Yet, the fact that the model is unable to predict accurately  $p_{el,p}$ ,  $U_{cell,p}$  and  $\eta_p(\mathbf{u})$  justifies the use of either RTO-MA or of the SCFO solver, since these two approaches/tools are capable of rejecting the effect of uncertainty and thus, tracking the changes in the set of optimal operating conditions.

For simulation purposes, we will consider the following scenarios for the (unknown and unpredicted) variations of the load:

1.  $p_{el}^S$  varies from 0.30 W/cm<sup>2</sup> to 0.38 W/cm<sup>2</sup> then back to 0.30 W/cm<sup>2</sup> every 90 minutes.
2.  $p_{el}^S$  varies randomly every 5 minutes between 0.30 and 0.38 W/cm<sup>2</sup>.

Again, please note that no knowledge of the two aforementioned scenarios is used at the implementation level.

### RTO of an industrial SOFC stack

The second case study discussed hereafter considers the optimization of the electrical efficiency of an industrial two-cells SOFC stack for HTceramix - SOFCpower. There is no available model for this stack, apart from the model of the experimental stack. The application of standard model-based method would then be again very hazardous. Similarly to Equation (7) however, the fuel utilization and the air ratio are perfectly known. On the other hand there is no way to predict accurately the power produced, the temperature of the cells and the cell potential. This means that the constraints on these three quantities will be implemented as “ $g_p$ ” in Equation (6), while constraints on fuel utilization and air ratio will be treated as “ $g$ ” in (6).

The objective is to maximize the electrical efficiency at a given, constant load. Note that this load is unknown at the beginning of the experiment. This is indeed a representative case study of the start-up of such devices for the customers of our industrial partner. The start-up phase is a critical step, and the stack needs to quickly provide the user with the required power, and then, to operate at the unknown optimal operating conditions for this load. Similarly to the case of the experimental cell stack, the operating window is constrained as follows (for the same reasons):

1. the cell potentials of the two cells have to be bigger than 0.78V,
2. the fuel utilization has to be below 80%,
3. the temperature of the cells should be between 700 and 850K,
4. the fluxes (of hydrogen and oxygen) and the current are bounded from above.

Note that a constraint on the temperature has appeared, which was not necessary for the experimental stack. The scenario considered for this case study is that at the beginning of the experiment, the power load jumps to the unknown value of 0.25 W/cm<sup>2</sup>.

### Dynamic RTO of a simulated Kite System

The idea of using kites as a renewable energy sources has received growing attention in recent years, both from industry and academia. This is motivated by the fact that tethered kites are deemed to be capable of accessing high altitudes at a much cheaper cost than wind turbines. At such altitudes the wind is not only stronger, but its speed and direction is also more stable. Since kites can fly at speeds many times that of the wind, a large aerodynamic force acts on the kite. This force is then directly transmitted to the ground via the cable, i.e. without requiring a tower, unlike wind turbines. This growing attention has led to the creation of several ‘kite-power’ start-ups (Skysails GmbH, Makani Power, Ampyx Power).

If the cable is connected to a generator, two phases can be envisaged: (i) Reel-out: the tension in the cable forcibly unwinds the reel, the *generator produces electricity* and (ii) Reel-in: *the generator works as a motor* to reel the cable back in. The use of tethered kites for producing power is, however, still a research field and, for industrial applications, a niche market. Optimizing the operation of the kites is thus highly desirable, as these devices must still prove their efficiency to convince a broader audience of their potential. For the example before, this means that there is a need for methods for designing a trajectory that maximizes the cable tension during phase 1, while minimizing the tension during phase 2.

Like in the previous sections, the standard approach would be to formulate a model-based problem, while it is widely admitted that constructing an accurate dynamic model of a kite is still an open problem. Several models have been proposed (Diehl, 2001; Argatov, Rautakorpi & Silvennoinen, 2009; Breukels, 2010), none of which are fully capable of accurately predicting a kite’s behavior. Also, the kite’s behavior is affected by time-varying disturbances, mainly the wind’s speed and direction. These

disturbances cannot be directly measured, as, due to wind shear, the wind at the kite's altitude is not the same as the wind at ground level. Hence, the need for a RTO method, but with the additional difficulty that a kite is a fast, dynamic system, i.e. a dynamic RTO approach. Another limitation is that solving a dynamic optimization problem can take a significant amount of time, which can be incompatible with the real-time operation of such a fast system. Yet what makes it tractable is the fact the optimization problem is indeed a periodic one. The kite should follow a trajectory in the air, which brings it back to its initial position. The aim of RTO-MA is thus to alter this trajectory in such a way that, from cycle to cycle, or from a series a several loops to another series of several loops, it rejects the effect of the disturbances on the performance of the kite.

The third case study, presented hereafter, discusses the real-time optimization of a simulated tethered kite for power production. Since the kite is a fast unstable dynamical system, which will inevitably crash without advanced online control, it is impossible to restrict the control layer to RTO alone. We are typically in a case whereby the fifth argument of (Serralunga et al., 2013) is not valid. We will show in the next section that RTO can be coupled to advanced process control in this peculiar case.

## 5 RESULTS

### RTO-MA of an experimental SOFC stack

Without entering into the finer details (Bunin et al., 2012), RTO-MA was first applied in its simplest form, i.e. only the 0<sup>th</sup>-order modifier terms (the epsilons in (5)) were used. This is justified as it has been shown experimentally that the solution is almost always determined by the constraints. At each re-optimization stage  $k$ , the following optimization problem was solved:

$$\begin{aligned}
 \mathbf{u}_{k+1}^* &:= \arg \max_{\mathbf{u}} (\eta_m := \eta(\mathbf{u}) + \varepsilon_k^\eta) \\
 \text{s.t. } p_{el,m}(\mathbf{u}) &:= p_{el}(\mathbf{u}) + \varepsilon_k^{p_{el}} = p_{el}^S \\
 U_{cell,m}(\mathbf{u}) &:= U_{cell} + \varepsilon_k^{U_{cell}} = p_{el}^S \\
 v(\mathbf{u}) &\leq 0.75 \\
 4 &\leq \lambda_{air} \leq 7 \\
 \dot{n}_{O_2} &\geq 3.14 \text{ ml.min}^{-1}.\text{cm}^{-2} \\
 I &\leq 30A
 \end{aligned} \tag{8}$$

With  $\eta(\mathbf{u})$ ,  $p_{el}(\mathbf{u})$  and  $U_{cell}(\mathbf{u})$  being the values of the electrical efficiency, of the power density and of the cell potential predicted by the model of (Wuillemin, 2009). Only 0<sup>th</sup>-order modifier terms are used that correspond to the difference between predicted and measured quantities at the previous iteration. Also, a unit gain exponential filter is applied to avoid too abrupt modifications of the optimization problem. This filter introduces thus, through its gains  $K$ , parameters that can be tuned to facilitate convergence to the plant optimum (Marchetti, 2009).

The modifier exponential filtering reads:

$$\varepsilon_k^X = (1 - K_X) \varepsilon_{k-1}^X + K_X (X_p(\mathbf{u}_{k-1}^*) - X(\mathbf{u}_{k-1}^*)) \tag{9}$$

, where  $X$  corresponds to  $\eta$ ,  $p_{el}$  and to  $U_{cell}$ . Equation (9) indicates that the 0<sup>th</sup>-order modifiers are indeed the filtered differences between the three measured values of the efficiency, of the power density and of the cell potential and the three corresponding predicted values, at the previous set of optimal operating conditions. Upon convergence, when  $k \rightarrow \infty$ , it is straightforward to show that  $\eta_p(\mathbf{u}_\infty^*) = \eta_m(\mathbf{u}_\infty^*)$ ,  $p_{el,p}(\mathbf{u}_\infty^*) = p_{el,m}(\mathbf{u}_\infty^*)$  and  $U_{cell,p}(\mathbf{u}_\infty^*) = U_{cell,m}(\mathbf{u}_\infty^*)$ , i.e. that the modified modeled constraints match the real constraints at the converged inputs. In other words, with the modifiers (in theory with both 0<sup>th</sup> and 1<sup>st</sup>-order modifier terms), the necessary conditions of optimality of the modified model-based problem match those of the real problem, and so do the optimal solutions.

Figure 2 depicts the implementation of the algorithm to the experimental stack. The modified problem of Equation (8) is solved for the current value of the power load and the obtained optimal inputs are applied to the steady-state model and to the stack in parallel. Due to model-mismatch and parametric uncertainty (inaccurate values of the model parameters  $\theta$ ), the measured values differ from the model predictions. These differences are filtered (top-right blocks) to compute the new value of the modifiers to implement in the modified problem of Equation (8).

For scenario 1, RTO-MA of (8) was solved every 30 minutes, a period that is sufficiently long to guarantee that the real stack has reached steady state, and thus that steady-state measurements are compared to predictions at steady state. For scenario 2, RTO-MA of (8) was solved every 10 seconds. Here, steady-state predictions are compared to transient measurements, since the dominant constant time of the temperature dynamics is about 30 minutes. This introduces additional model-mismatch, in that the steady-state model is compared to transient quantities. For both scenarios, the filter gains were also varied, and the information regarding the load changes was unknown at the implementation level – it was just used for simulating the behavior of the user (Bunin et al., 2012). Figure 3 depicts the results obtained for scenario 2. The grey areas in Figure 3 depict forbidden zones for the cell potential (top-right) and for the fuel utilization (bottom left). Solid blue lines depict measurements on the real stack, while the green curve is the unknown, randomly changing, power load.

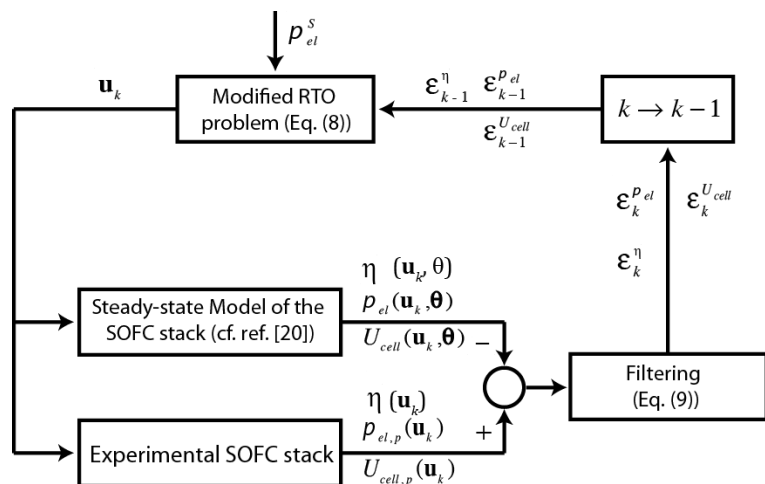
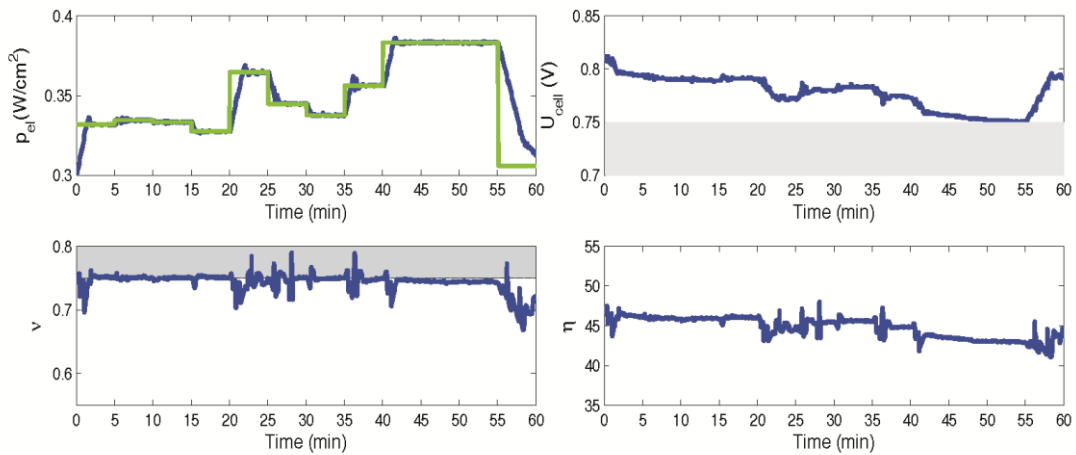

Figure 2. RTO-MA applied to the experimental SOFC stack.

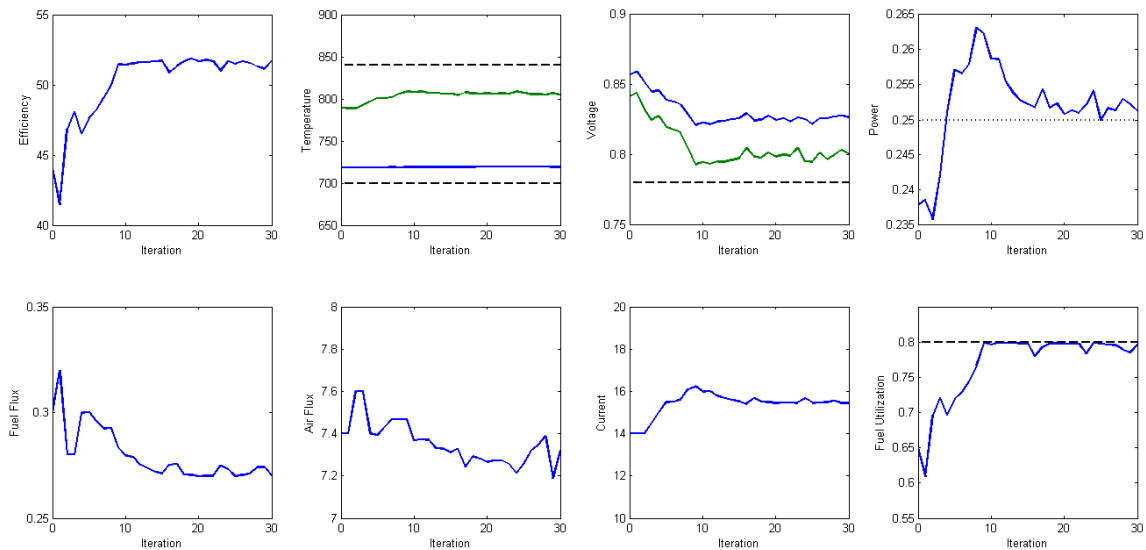

**Figure 3. Experimental Results of the Application of RTO-MA to the Experimental SOFC Stack for the 2<sup>nd</sup> scenario.**

It is readily seen from Figure 3 that the application of RTO-MA to the experimental SOFC stack is capable of (i) ensuring a fast tracking of the random (unknown) load changes (see the top left plot, where the blue curve follows the green one), (ii) maintaining the cell potential and the fuel utilization in the correct side of the constraints (top right, and bottom left, respectively), although marginal constraint violations are observed for fuel utilization that are due to the poor tuning of low level controllers. Finally (iii), the bottom right depicts the electrical efficiency. It is hard to quantify how optimal the performances are, since the optimal solution is not known *a priori*, but it is clear that the electrical efficiency is maintained at high values despite to trend of the random profile to increase the load. Our industrial partner validated these efficiencies to be close to the expected maximal performances, for the given loads. This is indeed a very good and promising result (Bunin et al., 2012), which allowed us to go one step further and apply the SCFO-solver to, this time, an industrial stack.

#### **Application of the SFCO-solver to an industrial SOFC stack**

The presentation here will be very short, as this mainly the direct application of the solver to the problem (7). The method of (Bunin et al., 2013) has been used for estimating the gradients on the real stack, while the solver has been coupled to a rudimentary gradient-descent with variable step size RTO algorithm. As said previously the solver is used here for optimizing the electrical efficiency at constant load. These are preliminary, unpublished results, but they were generated over a very short-time frame, which is a good indication of the applicability of our solver (Bunin et al., 2013b) to industrial facilities.

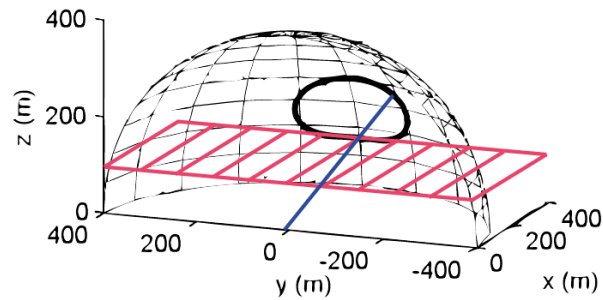

**Figure 4. Industrial Application of the SCFO-solver to a 2-cells SOFC stack.**

Inspecting Figure 4, where the results of the application of the solver to the industrial stack are depicted, it is clear that the solver achieves all its goals. Starting from an infeasible point, in that the power load of 0.25 is not delivered (1<sup>st</sup> row, 4<sup>th</sup> plot), the power produced is first maximized, until the power demand is reached. Meanwhile, one sees that the electrical efficiency jumps from 42% at an initial infeasible point to nearly 53% at a feasible set of operating conditions (1<sup>st</sup> row, 1<sup>st</sup> plot). Also, the constraints on inlet and outlet temperatures (1<sup>st</sup> row, 2<sup>nd</sup> plot), on the two cell potentials (1<sup>st</sup> row, 3<sup>rd</sup> plot) and on fuel utilization (2<sup>nd</sup> row, 4<sup>th</sup> plot) are strictly satisfied at any iteration. These preliminary results are very encouraging, and show a significant improvement in performances for an industrial (pilot-plant scale) energy system.

### Dynamic RTO of a simulated Kite System

The interested reader is invited to read (Costello, Francois & Bonvin, 2013) for the details regarding the formulation of the dynamic optimization problem. The goal is to maximize the average thrust, over one period (here corresponding to a series of loops), subject to a certain number of constraints (mainly here on the minimal altitude and on the fact that, at the end of the period, the position of the kite in space has to be equal to its initial position). For the application considered in this study (a kite used for pulling a boat, similarly to the products of Skysails GmbH), simulations with the simplified model of (Costello et al., 2013) showed that the solution of this optimization problem is composed of two arcs. The first arc is unconstrained while the second arc is one the height constraint, as illustrated by Figure 5, whereby the red-hatched area represents the height constraint, while the blue line depicts the cable.



**Figure 5. Nominal Optimal Path on the Sphere the Kite is Constrained to (the Direction of Flight is Clockwise).**

Because of uncertainty, this trajectory can vary significantly, as illustrated by Figure 6, where the evolution of the nominal path with regard to changes in the angle between the boat's direction and the wind relative to the boat is depicted, with the Black triangle and the blue line depicting the wing and the tether, respectively.

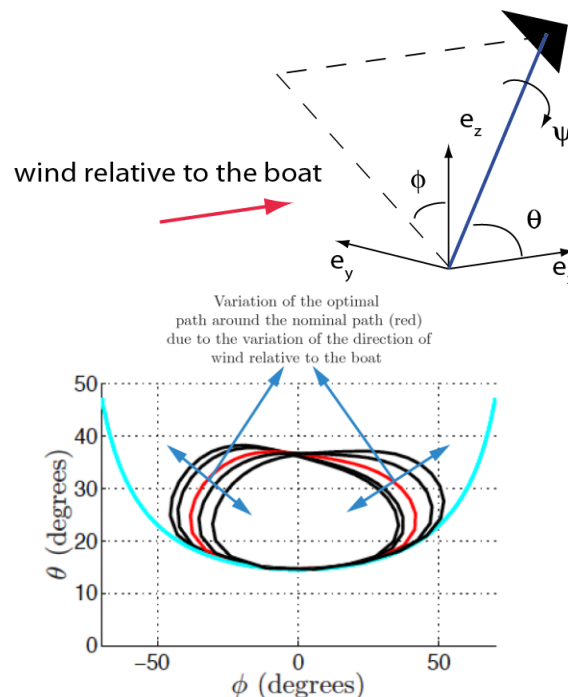

**Figure 6. System of Spherical Co-ordinates (Left Hand-Side) and Variation of the Nominal Path (Right-Hand Side) when the Angle between the Wind Relative to the Boat and the Boat's Velocity, Varies from  $-15$  to  $+15^\circ$  around its Modeled Value.**

Figure 7 depicts the scheme proposed in (Costello et al., 2013) to iteratively bring the required correction to the path that should follow the kite, in order to maximize the thrust. Since a trajectory is composed of an infinite number of points, adapting or correcting a *whole trajectory* is a challenging task. This is indeed impossible as such and the trajectory has to be parameterized with a finite number of parameters whose adaptation, from cycle-to-cycle, will yield the adaptation of the whole trajectory.

This scheme is constructed based on the following mathematical reasoning:

- The solution to the model-based dynamic optimization problem is an optimal



- path denoted by  $\mathbf{z}$ , which is indeed a path for the angles  $\theta$  and  $\phi$ ,
- At each cycle  $k$ , the kite follows the path  $\mathbf{z}_k$  with an ideal controller,
- Each path  $\mathbf{z}_k$  is composed of two arcs. The first arc is unconstrained, while the second corresponds to the period during which the kite flies at the minimum admissible altitude,
- This two-arc structure does not change with uncertainty, which is confirmed by the following 2 arguments:
  - a. In general, for parametric optimal control problems, small variations of the uncertain parameters do not alter the sequence and type of intervals in the solution (Maurer & Büskens, 2001),
  - b. Our simulation studies show that this is indeed also true for larger variations of the uncertain parameters (as shown in Figure 6), where the right-hand figure illustrates that the shape of the optimal path does not change much despite significant variation of the wind direction,
- This path  $\mathbf{z}$  can be parameterized with a finite number of parameters  $\theta$ ,
- A Taylor series expansion of the optimal path can be performed in the vicinity of the nominal value of the model parameters, for the unconstrained part of the path,
- This expansion yields the direction in which the path should be adapted to reject the effect of uncertainty on kite's performances, but does not provide the amplitude of the adaptation.

We propose to determine this amplitude and, in turn, adapt the path simultaneously, with the following RTO scheme (Costello et al., 2013).

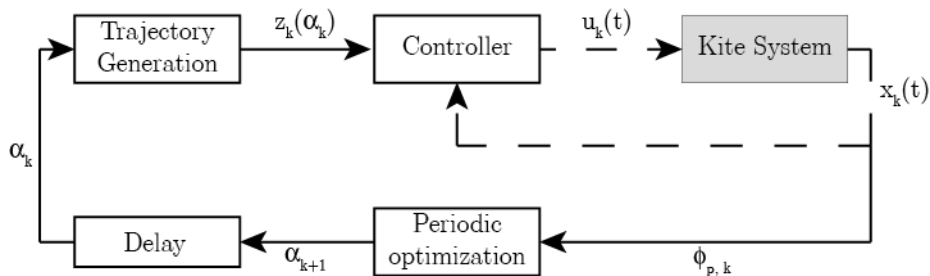

**Figure 7. The RTO Scheme for the Kite System**

Several remarks are in order, w.r.t. the three blocks: (i) the path generator maps the amplitude of the adaptation to the change in the trajectory to track, (ii) the controller allows the tracking of the path (typically by means of a Model-Predictive Controller) and (iii) the periodic optimizer adjusts the amplitude of the adaptation once per period, on the basis of the measurement of the average thrust over the  $k^{\text{th}}$  period (denoted  $\phi_{p,k}$ ).

In other words, the RTO algorithm (here a simple gradient descent method) uses  $\phi_{p,k}$  to compute the amplitude of modification  $\alpha_k$  that is used to alter the path to follow, along the directions  $\frac{\partial \mathbf{z}_{UC}^*}{\partial \pi}(\pi_0)$ , where  $\mathbf{z}_{UC}^*$  denotes the unconstrained nominal arc (i.e. the arc of the optimal trajectory, which does not correspond to the height constraint),  $\square$  denotes the uncertain model parameters and  $\square_0$  their nominal value. In the following the uncertain model parameters are the absolute wind of the speed  $v_0$ , the maximum value  $E_0$  of the glide ratio  $E$ , the constant term  $c$  of the quadratic penalization of the glide ratio  $E$  by the steering deflection  $u$  – with  $E = E_0 - cu^2$  and the angle  $\beta$  between the direction of the boat and the direction of the wind relative to the boat. For the unconstrained arc this adaptation law reads:

$$\mathbf{z}_k(\boldsymbol{\alpha}_k) = \mathbf{z}_{UC}^*(\boldsymbol{\pi}_0) + \boldsymbol{\alpha}_k \frac{\partial \mathbf{z}_{UC}^*}{\partial \boldsymbol{\pi}}(\boldsymbol{\pi}_0) \quad (10)$$

The constrained part of the arc does not need to be adapted since it is sufficient for the controller to track the highest altitude between  $\mathbf{z}_k(\boldsymbol{\alpha}_k)$  and  $h_{min}$ , where  $h_{min}$  denotes the minimal acceptable altitude. For further details regarding the adaptation law, the interested reader is kindly invited to read (Costello et al., 2013). In addition, a benchmark for kite control has been recently submitted by the authors, with all equations, parameters and simulation files in open access (Costello, Francois & Bonvin, 2014).

The application of (10) as the adaptation law of the scheme of Figure 7 to the simulated kite system leads to the improvement depicted in Figure 8. An improvement of 25% of the average thrust is observed over nearly 100 s, which corresponds more or less to ten loops.

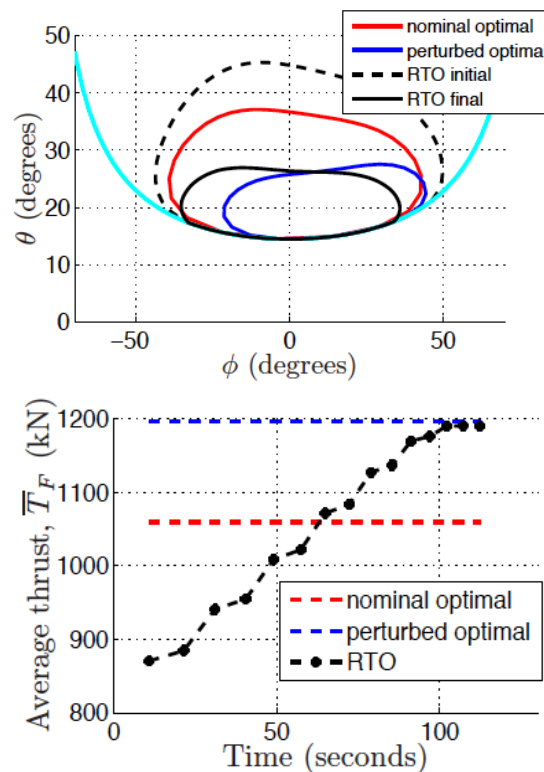

**Figure 8. Application of the RTO Scheme to the Simulated Kite System.**

On the left-hand side of Figure 8, the evolution of the path from the initial trajectory (black dotted) to the converged trajectory (solid black) is plotted. Note that, the converged (solid black) trajectory is almost symmetric, but not identical to the true optimal one (solid blue), while the solid red trajectory is the nominal one, i.e. the optimal solution obtained by model-based optimization of the nominal model. The fact that the method does not converge to an exactly identical or symmetric path is due to the fact that the path is only corrected along the directions defined by the model-based sensitivity analysis. However, as shown by the right-hand side of Figure 8, the loss in optimality is very marginal and the method is extremely efficient since it converges to near-optimal performance. It is then readily seen that the converged average thrust (black dotted) tends to the true solution (blue dotted). Note also that the converged trajectory exhibits the “bean-shape” of the optimal solution, although the initial path does not and despite the fact that the trajectory is only adapted along the directions defined by the model-based sensitivity analysis. This means that the

directions defined by the sensitivity analysis, which are used for the adaptation of the path, are the most important ones. Overall, for this uncertainty scenario, the performance increases by 25% in only two minutes.

## 6 DISCUSSION

In the previous section, three apparently different RTO methods have been successfully applied to three different energy systems.

RTO with Modifier Adaptation was first applied to an experimental fuel cell stack. The goal was to maximize the electrical efficiency of the stack under changing power-load conditions. The inspection of Figure 3 shows that it is indeed possible to maintain a high level of electrical efficiency (more than 40%) despite random changes of the power load. The constraints on cell potential and on fuel utilization were respected, apart from “spikes” occurring mainly because of the limitations of the lower level controllers. RTO-MA was applied in its simplest form, that is, with constraint adaptation only. This was made possible by the fact that the optimal solution is governed by constraints; the constraint on cell potential is active at high power load while the constraint on fuel utilization is active at lower power loads. Other RTO approaches could have been applied. RTO-TS (Marlin et al., 1997) could have been an option. But there would have been no guarantee that the converged inputs would have been the optimal ones, as the available model is thought to suffer from structural mismatch with the real stack. NCO-tracking and Self-Optimizing Control (François et al., 2005; Skogestad, 2000) or extremum-seeking control (Li, 2013; Guay et al., 2014) could have been possible also, mainly because of the observation regarding the activity of the constraints. However, while RTO-MA only requires the knowledge that the *solution is governed by constraints*, both NCO-tracking and Self-Optimizing Control would have required it to be known *in advance that the constraint on cell potential is active at high power load while the constraint on fuel utilization is active at lower power loads*. From a practical viewpoint this is not a huge difference, but methodologically speaking, this means that RTO-MA can be as efficient with less assumptions.

One limitation of RTO-MA is that it can only be proven that the constraints are satisfied *upon convergence*. In the example of Figure 3, this was not an issue and, apart from the aforementioned spikes, constraints were satisfied during the transient phases also. There is, on the other hand, no guarantee that in another situation, the same behavior would be observed. This justifies the use of the SCFO solver, which is capable of forcing convergence to the true plant optimum, with strict feasible iterates. The unpublished results of Figure 4 illustrate the potential of this solver (and of the underlying theory), as the electrical efficiency was increased to more than 52% without any violation of the constraints on temperature, cell potential and fuel utilization. No other RTO method can lead to the same result since, to the best of our knowledge, the SCFOs are the first attempt to develop a complete theory to enforce simultaneously *convergence* and *strict feasibility of all iterates*. As virtually no model was available for this industrial stack, derivative-free optimization (Conn, Scheinberg, & Vicente, L.N., 2009) could have been applied. But there would not have been any guarantee that iterates would have been feasible. This is made possible with the SCFO solver, the price to pay being a relatively slow rate of convergence (nearly 20 iterations for the example of Figure 8). This is indeed acceptable for two reasons : (i) the industrial stack is supposed to work at constant load, so these iterations have only to be performed once and (ii) no model was used at the implementation level apart from fuel utilization and air ratio. Indeed, other derivative-free algorithms are generally much slower.

For these two cases, note that what lets us claim that convergence to the true optimum of the fuel cells stacks was observed is indeed the intrinsic property of the two methods. RTO-MA and the solver cannot but converge to the true solution. Otherwise it would have been impossible to claim so, since by essence, the optimum of any real system is unknown in advance.

The third illustrative example was the dynamic real-time optimization of a simulated tethered kite. Two models were developed. First, a simplified model was assumed to be available that was used for control and optimization purposes. The second more detailed model was only used for simulation purposes, i.e. it was *not* used at the implementation level (Costello, Francois & Bonvin, 2014). There is thus, a high level of plant-model mismatch, and standard optimization methods would not have been applicable. With the combination of RTO and control used here, the results show a significant cycle-to-cycle improvement of the efficiency of the kite as shown in Figure 8. Since this is a simulated example, the real optimal trajectory can be computed for comparison with the converged one. Convergence to an almost symmetric trajectory to the optimal one was observed, over only a few cycles. Other RTO methods could have been applied, like NCO-tracking. But the specificities of the optimal trajectory that is mainly composed here of an arc governed by the sensitivities, make the use of NCO-tracking very much less straightforward. Advanced control techniques are investigated in the kite community (such as nonlinear model predictive control (Diehl, 2001)), but the controller used in our study is far less elaborate, and thus, less complicated to understand, design, tune and maintain for practitioners. We have also developed a small-scale experimental system, and the first experiments were carried successfully a few weeks ago. Their presentation goes beyond the scope of this article, but the corresponding results will be analyzed in detail and submitted for publication in a journal soon.

In (Serralunga et al. 2013) one of the arguments in favor of the use of RTO to energy systems was its potential to reduce the need for an advanced process control layer. This is true for systems whose dynamical behavior is not too complicated (Francois & Bonvin, 2014). For instance, the application of RTO-MA with a static model to the experimental fuel cells stack is a good example of such a successful application. In our example, we applied RTO sufficiently frequently, relative to the time scale of the temperature variations, to remove the need for temperature control. RTO was, in some sense, used as a controller. Nevertheless, this was also made possible because the temperature dynamics are stable and do not exhibit any complicated behavior. Our last example, i.e. the simulated kite, is an example for which this is not possible. The fact that the dynamics of the kite are fast and unstable calls for an advanced process-control layer, without which RTO will not be able to maintain the kite in the air. However, this shows that, similarly to what is performed in the chemical industry, RTO can be applied as a master layer to the control layer for energy systems.

## 7 CONCLUSIONS

In this article, the potential benefits of applying a selection of RTO methods to energy systems has been illustrated. It has been shown how these methods exploit the available measurements to compensate for model inaccuracies and to reject the effect of uncertainty and disturbances to optimize the performance of the real system at hand. In the field of energy, this is a highly desired property since, as it has been illustrated in this article, it ensures optimality and constraint satisfaction despite changes of the load or of the source availability. The focus has been on the methods developed by the authors and especially on RTO-MA and on the SCFO-solver, with simulated, experimental and industrial examples.

The application of dynamic RTO and RTO-MA to a simulated kite system and to an experimental SOFC stack, respectively, has shown the potential of this technique to handle simultaneously parametric uncertainty, structural model-mismatch and disturbances in the context of variations of the availability of the power source or of the load, while improving the performances of the corresponding energy systems. Also, unpublished results concerning the successful application of the SCFO-solver in an industrial context were presented, which show that these techniques can bridge the gap that still remains between the academic and the industrial worlds. But it is the opinion of the authors that the this paper's message is indeed broader than the sole focus on the application of well-chosen techniques to well-chosen systems.

The key message is that RTO methods and algorithms exist, which can be tailored to one's specific energy system. Some of these techniques are indeed (almost) ready to be used by practitioners for the online, in-situ, improvement the operation of energy systems, even when the system at hand is hard to model. Meanwhile, the strength of the most recent methods is that they remain relatively easy to apply despite their strong theoretical foundations. As illustrated in this article, significant improvements can be obtained in terms of electrical efficiency of SOFC stacks, where it is made possible to track load changes at maximum electrical efficiencies. Meanwhile, on-going work on kites has shown that such methods can reject the effect of the changes in the availability of the source (here the direction and strength of the wind) for the most innovative renewable energy systems.

One of the main limitations to a wide use of the most innovative energy systems is their prohibitive costs. Optimization is therefore a must, but it is complicated by the simultaneous difficulties of : (i) obtaining an accurate model of the system at an affordable cost, (ii) handling the various sources of uncertainty, among which the disponibility of the source for renewable energy systems and (iii) handling the changes of the load, which is fully in the hands of the user and is thus hardly predictable. Meanwhile the most recent and innovative optimization methods are generally considered to be too complicated to be applied in the industry. Also, with the high number of different optimization problems that can be formulated, calling for different solution methods, practitioners tend to get lost and to doubt of the applicability of the methods. This article has shown that RTO-MA and the SCFO solver, as well as most RTO methods, are indeed particularly well suited for energy systems. This is due to their intrinsic ability to handle modeling errors, model mismatch and process disturbances, but also to their capacity to be tailored to one's specific application. In the future, such methods could help significantly reduce the operating costs of the most innovative energy systems. The satisfaction of operating constraints is also key for fuel cells (as constraints are correlated to their lifetime), for kites (as violating constraints generally means crashing the kite), and indeed for most energy systems. In this context, the ability of RTO methods to operate energy systems optimally and to guarantee constraint satisfaction is an undeniable advantage. The development of such methods will help, we hope, to change the way industry operates energy systems. This was the case at least for our industrial partner, for which the application of the solver has led to a significant improvement of the electrical efficiency -- a major commercial argument, together with the expected lifetime of the cells.

## ACKNOWLEDGMENTS

Special thanks go to M. Gene Bunin for his theoretical work on the SCFO and for his experimental work on the SOFC. The authors would also like to thank all the Masters Students involved in the development of the Kite System, the SwissKitePower consortium and the HTCeramix Company.

## REFERENCES

- Argatov, I., Rautakorpi, P., & Silvennoinen, R. (2009). "Estimation of the mechanical energy output of the kite wind generator". *Renewable Energy*, Vol. 34, No. 6, 1525 - 1532.
- Ariyur, K.B., & Kristic, M. (2003). *Real-Time Optimization by Extremum-Seeking Control*, John Wiley and Sons, New-Jersey, USA.
- Bazarrá, M., Sherali, H., & Shetty, C., (1993). *Nonlinear Programming: Theory and Algorithms*, John Wiley and Sons, 2<sup>nd</sup> edition: New York, USA.
- Boyd, S., & Vandenberghe, L., (2004). *Convex Optimization*, Cambridge University Press.
- Breukels, J., (2010). *An Engineering Methodology for Kite Design*. (Doctoral thesis, Delft University of Technology, The Netherlands, Retrieved from [http://www.lr.tudelft.nl/fileadmin/Faculteit/LR/Organisatie/Afdelingen\\_en\\_Leerstoelen/Afdeling\\_AEWE/Applied\\_Sustainable\\_Science\\_Engineering\\_and\\_Technology/Publications/doc/Thesis\\_Jeroen\\_Breukels\\_Compressed.pdf](http://www.lr.tudelft.nl/fileadmin/Faculteit/LR/Organisatie/Afdelingen_en_Leerstoelen/Afdeling_AEWE/Applied_Sustainable_Science_Engineering_and_Technology/Publications/doc/Thesis_Jeroen_Breukels_Compressed.pdf)).
- Bunin, G.A., Wuillemin, Z., Francois, G., Nakajo, A., Tsikonis, L., & Bonvin, D., (2012). "Experimental Real-Time Optimization of a Solid Oxide Fuel Cell Stack via Constraint Adaptation", *Energy*, Vol. 39, No. 1, 54-62.
- Bunin, G.A., Francois, G., & Bonvin, D. (2013a). "The SCFO Real-Time Optimization Solver: Users' Guide (version 0.9.4)", URL: [//infoscience.epfl.ch/record/186672](http://infoscience.epfl.ch/record/186672), (accessed 15 August 2013).
- Bunin, G.A., Francois, G., & Bonvin, D. (2013b). "From Discrete Measurements to Bounded Gradient Estimates: A Look at Some Regularizing Structures", *Ind. Eng. Chem. Res.*, Vol. 52, No. 35, 12500-12513.
- Bunin, G.A., Francois, G., & Bonvin, D., (2014a). "Feasible-side global convergence in experimental optimization", *submitted to SIAM Journal on Optimization*.
- Bunin, G.A., Francois, G., & Bonvin, D. (2014b). "On linear and quadratic Lipschitz bounds for twice continuously differentiable functions", Unpublished, arXiv [math.OC] 1406.3991, URL: <http://arxiv.org/abs/1406.3991>, accessed 15 November 2014.
- Conn, A.R., Scheinberg, K., & Vicente, L.N. (2009). *Introduction to Derivative Free Optimization*. MPS-SIAM Book Series on Optimization. Philadelphia: SIAM.
- Costello, S., Francois, G., & Bonvin, D. (2013). "Real-Time Optimization for Kites", In proceedings of the 5<sup>th</sup> IFAC International Workshop on Periodic Control Systems, Caen, France, 64-69.
- Costello, S., François, G., & Bonvin, D., (2014). *Kite Control - A Benchmark Problem for Advanced Control and Dynamic Optimization*, (Working paper 201679). EPFL, Lausanne, Switzerland, URL: <http://infoscience.epfl.ch/record/201679?ln=en>.
- Diehl, M. (2001). *Real-Time Optimization for Large Scale Nonlinear Processes*. (Doctoral thesis, Ruprecht-Karls-Universität Heidelberg, Germany. Retrieved from <http://archiv.ub.uni-heidelberg.de/volltextserver/1659/>).
- Diethelm, S., Van Herle, J., Wuillemin, Z., Nakajo, A. Autissier, N., & Molinelli, M., (2008). "Impact of materials and design on solid oxide fuel cell stack operation", *J. Fuel Cell Sci. and Tech.*, Vol. 5, No. 3, 1-6.
- Forbes, J.F., & Marlin, T., (1996). "Design Cost: A systematic approach to technology selection for model-based real-time optimization systems", *Comput. Chem. Eng.*, Vol. 20, 717-734.
- Francois, G., Srinivasan, B., & Bonvin, D., (2005), D. "Use of Measurements for Enforcing the Necessary Conditions of Optimality in the Presence of Uncertainty and Constraints", *J. of Process Cont.*, Vol. 15, No. 6, 701-712.
- Francois, G., Srinivasan, B., & Bonvin, D., (2012). "Comparison of Six Implicit Real-Time Optimization Schemes", *Journal Européen des Systèmes Automatisés*, Vol. 46, No. 2-3, 291-305.

- Francois, G. and Bonvin, D., (2013). "Use of Convex Model Approximations for Real-Time Optimization via Modifier Adaptation", *Ind. Eng. Chem. Res.*, Vol. 52, No. 33, 11614-11625.
- Francois, G. and Bonvin, D., (2014). "Use of Transient Measurements for the Optimization of Steady-State Performance via Modifier Adaptation », *Ind. Eng. Chem. Res.*, Vol. 53, No. 13, 5148-5159.
- Gao W., & Engell, S., (2005). "Iterative Set-point Optimization of Batch Chromatography", *Comp. Chem. Eng.*, Vol. 29, pp. 1401-1409.
- Guay, M., Moshksar, E., & Dochain, D. (2014). "A Constraint Extremum-Seeking Control Approach", *International Journal of Robust and Nonlinear Control.*, doi: 10.1002/rnc.3254.
- Li, X. (2013). *Investigation of Some Self-Optimizing Control Problems for Net-Zero Energy Buildings*. (Doctoral Thesis, The University of Wisconsin-Milwaukee, USA. Retrieved from <http://dc.uwm.edu/cgi/viewcontent.cgi?article=1132&context=etd>).
- Korn, G.A., & Korn, T.M., (2000). *Mathematical Handbook for Scientists and Engineers*, Dover Publications.
- Marchetti, A. (2009). *Modifier-adaptation methodology for real-time optimization* (Doctoral Thesis No. 4449, EPFL, Lausanne Switzerland. Retrieved from <http://infoscience.epfl.ch/record/138485?ln=en>).
- Marchetti, A., Chachuat, B., & Bonvin, D., (2009). "Modifier-Adaptation Methodology for Real-Time Optimization", *Ind. Eng. Chem. Res.*, Vol. 48, 6022-6033.
- Marlin, T. & Hrymak, A. (1997). "Real-Time Operations Optimization of Continuous Processes.", in proceedings of the AIChE Symposium Series – CPC-V, 93 (1997), Baltimore, USA, 156-164.
- Maurer, H. and Bükens, C., (2001). Sensitivity analysis and real-time control of parametric optimal control problems using boundary value methods. In M. Grötschel, S.O. Krumke, & J. Rambau (Eds.) , *Online Optimization of Large Scale Systems*, (pp.17–56), Springer-Verlag, Berlin Heidelberg.
- Nakajo, A., Wuillemin, Z., Van Herle, J., & Favrat, D., (2009). "Simulation of thermal stresses in anode-supported solid oxide fuel cell stacks. Part I: probability of failure of the cells", *J. of Power Sources*, Vol. 29, No. 1, 203-215.
- Rotava, O., & Zanin, A. C., (2005). "Multivariable control and real-time optimization – An industrial practical view", *Hydrocarbon Processing*, Vol. 84, 61-71.
- Serralunga, F.J., Mussati, M.C., & P.A. Aguirre, (2013). "Model Adaptation for Real-Time Optimization in Energy Systems", *Ind. Eng. Chem. Res.*, Vol. 52, 16795-16810.
- Skogestad, S., (2000). "Plantwide Control: The Search for the Self-Optimizing Control Structure", *J. of Process Cont.*, Vol. 10, 487-507.
- Srinivasan, B., Francois, G., & Bonvin, D., (2011). "Comparison of Gradient Estimation Methods for Real-time Optimization", *Comput.-Aided Chem. Eng.*, Vol. 29, 607-611
- Wuillemin Z. (2009). *Experimental and modeling investigations on local performance and local degradation in SOFC*. (Doctoral thesis No. 4525, EPFL, Lausanne Switzerland. Retrieved from <http://infoscience.epfl.ch/record/140999?ln=en>).
- Zeng, Y., Cai, Y., Huang, G., & Dai, J. (2011). "A Review on Optimization Modeling of Energy Systems Planning and GHG Emission Mitigation under Uncertainty". *Energies*, Vol. 4, 1624-1656.