

Stanislav KOVÁŘ¹, Jan VALOUCH¹

Faculty of Applied Informatics, Tomas Bata University in Zlín (1)

doi:10.15199/48.2016.05.40

Electromagnetic susceptibility of IP camera

Abstract. Electromagnetic susceptibility is an important ability of all electronic and electric devices which are located in the area with electromagnetic interference. The paper is focused on IP camera and it describes its levels of electromagnetic susceptibility against electromagnetic interference. The measurement must be performed according to standard EN 50130-4 ed. 2.

Streszczenie. Podatność elektromagnetyczna jest ważnym parametrem określającym odporność urządzenia na zakłócenia elektromagnetyczne. W pracy badano kamerę IP w oparciu o normę EN 50130-4 ed. 2. **Podatność elektromagnetyczna kamery IP**

Keywords: Electromagnetic susceptibility, IP camera, semi-anechoic chamber, electromagnetic interference.

Słowa kluczowe: podatność elektromagnetyczna, kamera IP

Introduction

Electromagnetic susceptibility is based on the physical phenomenon called electromagnetic radiation, and it consists of an electric and a magnetic component. Vectors of electric and magnetic field are mutually orthogonal and have the same phase. Electromagnetic radiation can originate in two ways, which are following:

- accelerating motion of charged particles - radiation with a less frequency and energy, but the wavelength is longer (radio wave).
- the changes in the internal structure of the particles - the radiation has a greater energy and frequency, but the wavelength is less (X-ray radiation, etc.).

Electromagnetic radiation is generated by all electrical and electronic devices. Radiation energy is transmitted in parts, and it is directly proportional to the frequency. The amount of particles (photons) depends on the intensity of radiation.

Electromagnetic susceptibility (EMS) is defined as the ability of equipment or system to operate without a fault or with strictly defined permissible influence in an electromagnetic environment. The aim of electromagnetic susceptibility is to increase the electromagnetic immunity of receivers (devices that are disturbed) by technical means (filters, shielding, etc.). EMS mainly studies the elimination of the consequences of interference than identifying its causes (electromagnetic interference). [1]

Equipment under test

IP camera may be defined as a camera and computer in one. IP cameras are able to scan and send out a data through IP network in monitoring units. An authorized person can freely treat with the retrieved data (displaying, managing, storing). IP cameras are composed of a circumferential sensor, lens, memory (RAM, flash) and one or more processors. The processors control the functions of camera (video analysis, image processing, etc.). The memory saves firmware of camera (RAM) and the obtained image.

The testing of EMS was performed on security camera Vivotek FD8136B F3. Vivotek has following specifics:

- CPU - Multimedia SoC (System-on-Chip),
- image sensor - 1/4" Progressive Scan CMOS,
- RAM - 256MB,
- flash memory - 16MB,
- supply via POE data cable,
- High Definition (HD).

System-on-Chip is designed as a standalone system which include own microprocessor or microcontroller, memory and interface. CPU operates with radio frequency (Wi-Fi). [4]

Measuring equipment

The measurement of electromagnetic susceptibility was realized on the laboratories of EMC on Tomas Bata University in Zlín. A semi-anechoic chamber was used for this purpose which the laboratories are equipped. The semi-anechoic chamber disposes pyramidal absorbers which eliminate measurement errors caused by random reflections. The chamber included just an antenna and probe at the time of the measurement, other measuring devices was located outside of the chamber. HL046 antenna (Fig. 1) operates in the frequency range from 80MHz to 1,3GHz, electric field probe HI-6015 operates in the frequency range from 100kHz to 6GHz. Both devices are suitable to perform tests of EMS according to EN 50130-4.



Fig. 1. A log-periodic antenna HL046

The entire measurement was carried out using the following measuring equipment:

- HL046 (Rohde&Schwarz) - a log-periodic antenna,
- HI-6105 (ETS-Lindgren) - an electric field probe,
- SMB 100A (Rohde&Schwarz) - a signal generator (9kHz - 6GHz),
- ESU (Rohde&Schwarz) - EMI test receiver (20Hz - 8GHz),
- 150W1000 (Amplifier Research) - an amplifier (80 - 1000MHz, 150W),
- 80S1G4 (Amplifier Research) - an amplifier (0,7 - 4,2GHz, 80W),
- 150A250 (Amplifier Research) - an amplifier (100kHz - 250MHz),
- OSP 130 (Rohde&Schwarz) - a switch and control unit,

- OSP 150 (Rohde&Schwarz) - a switch and control unit,
- EMC32 (Rohde&Schwarz) - EMC measurement software.

Disposition of EUT

The IP camera is connected according to its proposal as part of CCTV (Closed Circuit Television). Because the aim of the measurement was specified electromagnetic susceptibility of IP camera, all parts of CCTV (except the camera) were located outside of the semi-anechoic chamber. This configuration ensured the accurate results, which were not distorted by other parts of the CCTV.

The standard EN 50130-4 determines the requirements that shall be met during the measurement. EUT (equipment under test) must be located on the insulated support (for example the wooden table - Fig. 3) and all cables should be routed through the rear edge of the insulated support. Surplus parts of cables must be folded. The electric field probe should be placed behind EUT in the same height as EUT.

The distance between the log-periodic antenna and EUT varied from 1 - 3 m to ensure a sufficient level of interference which EUT must be exposed. The area between the antenna and EUT was filled the absorbers. The PoE adapter was located on the ground plane at the foot of the table. The situation is shown in the following figures (Fig. 2).

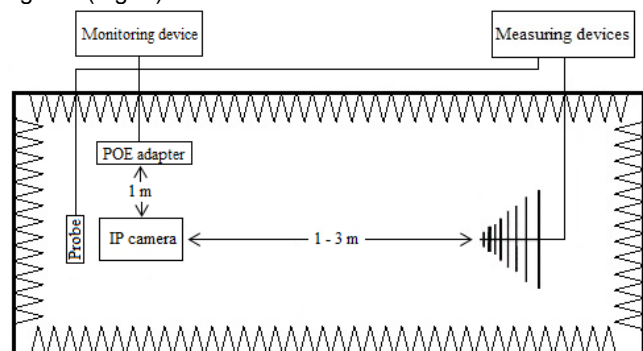

Fig. 2. The configuration in the semi-anechoic chamber with the PoE adapter.

A spatial distribution of EUT in the semi-anechoic chamber represents the following figure (Fig. 3). The figure shows the differences of height between the IP camera and the PoE adapter.

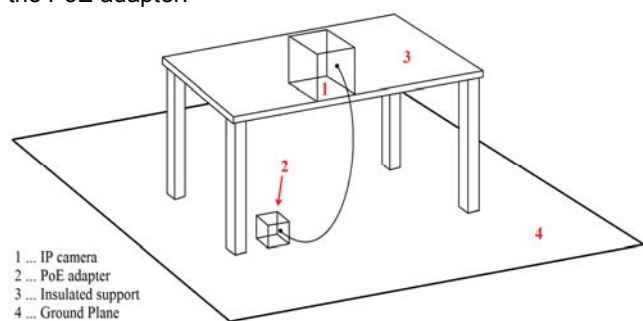

Fig. 3. The configuration of EUT

Fig. 3 shows the position of the PoE adapter that was selected so as to minimize influence the measurement results. A plan view (Fig. 4) describes the disposition of EUT.

Process of measuring

The IP camera was in the active (functional) state throughout the testing, and it transmitted the image of the scanned scene via a shielded twisted pair cable to the notebook. This state was necessary for an assessment of electromagnetic susceptibility of the camera. The software

of the camera visualized all the information on the laptop screen. All changes or faults were observed on the itself device during the testing (for example a failure of a indication diode).

The camera and the PoE adapter were permanently located in the semi-anechoic chamber. The monitoring (control) unit was situated outside of the chamber because of the opportunity monitored changes in the transmitted image.

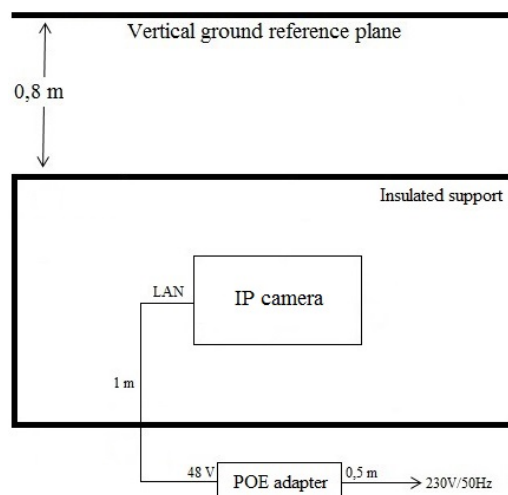

Fig. 4. The disposition of EUT – a plan view.

The position of the antenna was changed in the range from 1 - 3 m, in order to ensure the required strength of an electromagnetic field. The testing was performed using a Peak detector which indicates the maximum value of the electromagnetic field for each measured frequency. Conversely, a Quasi-Peak detector works with a time; it evaluates several samples for each measured frequency. The Quasi-Peak detector is more accurate, but it is more time consuming. Therefore, the Peak detector was used.

All measurement was performed in accordance with standard EN 50130-4 ed. 2, which is designed for alarm systems, including CCTV. The entire process of measurement can be summarized in the next few steps.

1. Preparing the workplace

The first phase included a preparing of a workplace, ie. a selection of a suitable measuring equipment (antenna, probe, etc.), a measurement environment (semi-anechoic chamber) and the deployment of the equipment in the chamber.

2. Configuration of EUT

The second step comprises a configuration of the test device, ie. an identification of the parts to be tested (IP camera), a definition of a location the EUT and the preparation of all parts of the EUT (PoE, laptop, shielded twisted pair cables). The configuration is shown in Fig. 2 - Fig. 4.

3. Wiring of EUT

Next step determines wiring of EUT, ie. an interconnection of all parts of the CCTV, a revision of wiring and all system functions.

4. Changes of measurement

This phase includes all the changes of configuration or equipment during measurement, ie. a change of distance between the antenna and EUT (1 - 3 meters - Fig. 2), a change of position the equipment, etc.

5. Evaluation of results

The last phase includes the analysis and evaluation of results.

Results of measurement

This part of the paper presents the results which were obtained during the measuring. A harmonic unmodulated signal (which corresponds to the values of field strength) is amplitude modulated to a depth of 80% by the low-frequency harmonic voltage of 1 kHz. The strength of the electric field should be set to a value of 10V/m.

Each section of this chapter contains two graphs. One of the figures describes a dependence of Amplifier Output Forward (Amp Out For) on a frequency and second figure shows the dependence of immunity level on the frequency. The y-axis shows the Amp Out Fwd in Watts and Immunity level in V/m. The x-axis maps the frequency in Hz.

Test 1

Test 1 describes the situation when the distance between the antenna and EUT is 3m. Fig. 5 shows the immunity level and Fig. 6 shows the wattage of amplifiers.

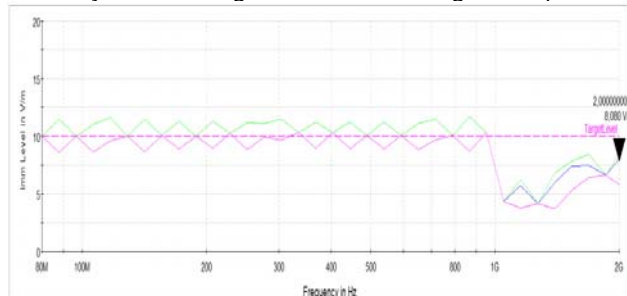

Fig. 5. Immunity level – test 1.

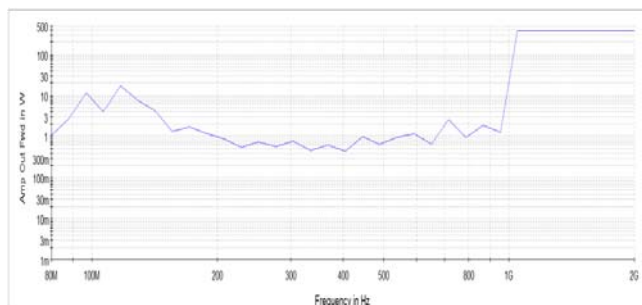

Fig. 6. Amp Out Fwd – test 1.

Fig. 5 illustrates three color waveforms which mean an immunity level (blue color), a minimum of immunity level (violet) and a maximum of immunity level (green). The frequency range is from 80MHz to 2GHz and the wattage range is from 1mW to 500W.

The IP camera worked properly during the testing of EMS, so-called no disturbances of the image were reported. However, the camera signalled a fault condition at certain frequencies. The frequencies were in the range from:

- 500MHz to 800MHz,
- 1,7GHz to 2GHz.

The disturbances were reported by an audible alarm.

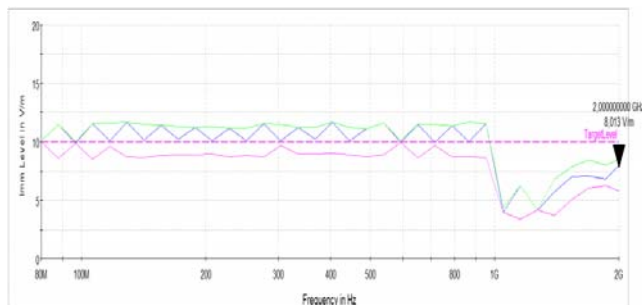

Fig. 7. Immunity level – test 2.

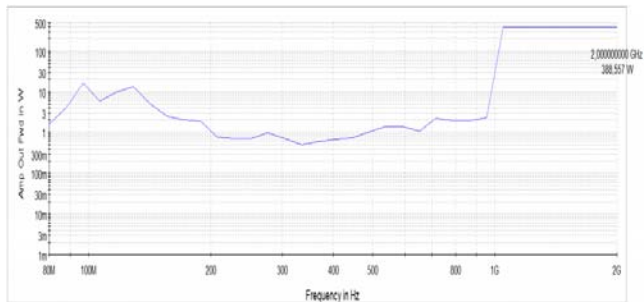

Fig. 8. Amp Out Fwd – test 2.

Test 2

The second measurement represents the situation when the distance between the antenna and EUT was 2,5m.

The color waveforms are similar as in previous case; however, the immunity level is stronger than in the first case. The process of wattage is slightly different from the first case in the frequency range from 300MHz to 1GHz, which is the value when the amplifiers are switched.

The camera indicated a defect in frequency ranges between:

- 300 - 450MHz,
- 500 - 900MHz,
- 1,5 - 1,9GHz.

The most significant interference was in frequencies:

- 400MHz,
- 700 - 800MHz,
- 1,7GHz.

The audio system of the camera reported the disturbances by intense tones.

Test 3

The next measurement was performed by the measuring antenna in the distance 2,5m from the IP camera, but the cover of the camera was removed.

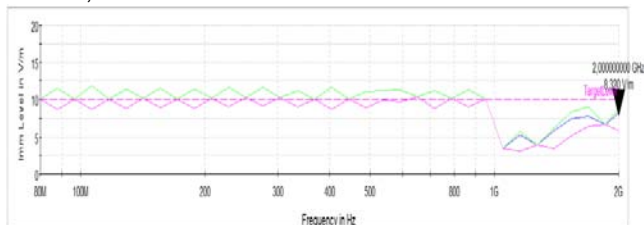

Fig. 9. Immunity level – test 3.

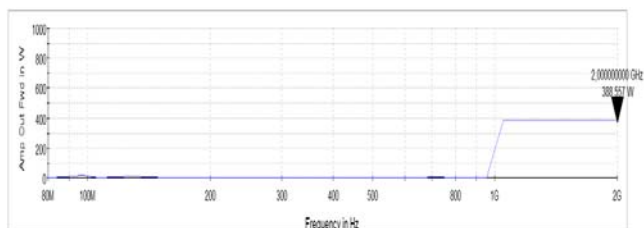

Fig. 10. Amp Out Fwd – test 3.

The changes of immunity level are fractional and the values are similar to those in test 1. The significant changes start up around frequency value 950MHz thus the value in which the amplifiers switch over. Fig. 10 shows the process of wattage in a different scale than it was in last cases. The wattage is constant from the frequency approximately 1,1GHz.

The IP camera as in the previous cases indicates the disturbance at certain frequencies. The frequency segments that the camera recorded are following:

- 367 - 953MHz,
- 1,6 - 2GHz.

Acoustic signaling was most intense in the frequencies:

- 489,2MHz,
- 716 - 800MHz.

As expected, the plastic cover does not have any impact on the reliability of the camera because it reliably transmits information to the laptop. The acoustic signaling indicates a fault, but no visible defect was visible on the obtained image of the camera.

Test 4

The following figures illustrate the results of measurement when the antenna was set at the distance of 2 m from EUT. The IP camera was left without its plastic cover, which have got no influence the level of susceptibility.

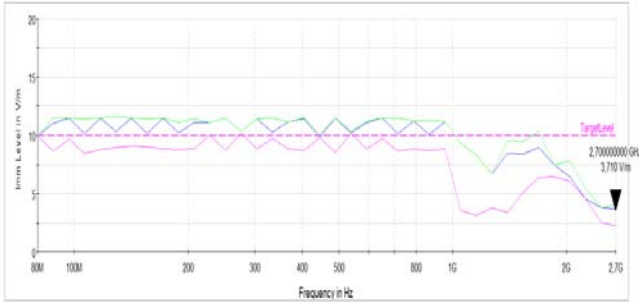

Fig. 11. Immunity level – test 4.

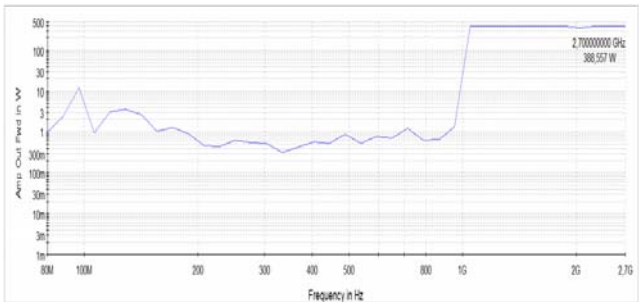

Fig. 12. Amp Out Fwd – test 4.

The frequency range of the immunity level was extended up to the frequency of 2.7GHz (standard EN 50130-4 ed.2). Unlike the previous cases, the electric field strength is higher which is reflected in Fig. 11. The immunity level reaches higher values in the frequency range from 1 to 2GHz, and then a sharp decline follows. The course of the performance of amplifiers is more or less the same, the slight decline at around the value 2GHz is the only one exception.

As has already been stated many times, the IP camera recorded the several the acoustic fault indication during the measurements. The disturbances did not affect the image quality; respectively the changes were not visible to the naked eye. The frequencies in which the equipment reported the disturbances are following:

- 404 - 761,3MHz,
- 1,535 - 1,805GHz.

Camera gave a most intense warning at these frequencies:

- 444,7MHz,
- 761,3MHz.

Test 5

Test 5 interprets the results when the distance between the antenna and EUT was only 1m. The color waveforms are the same as previous cases.

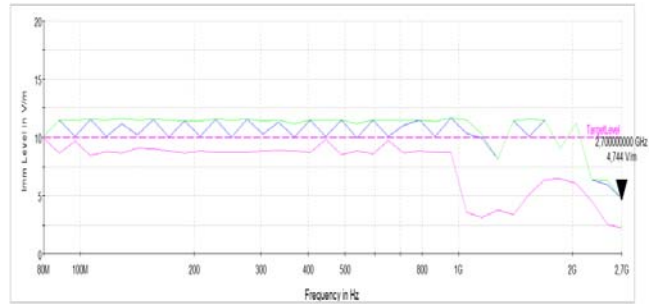

Fig. 13. Immunity level – test 5.

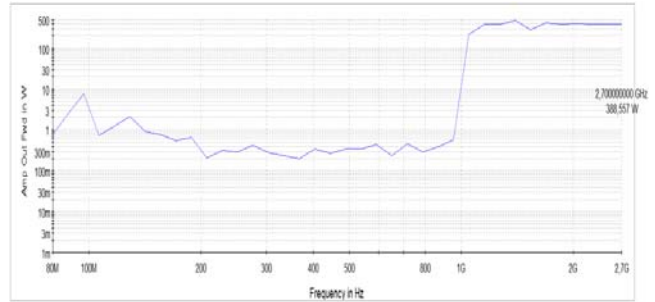

Fig. 14. Amp Out Fwd – test 5.

The change of the distance between EUT and the antenna is illustrated in Fig. 13 because the maximum and average values of immunity mostly move around the value of 10V / m. The values of the resistibility sharply decline from the frequency of 2GHz, because the applied amplifiers are not able to generate the sufficiently high field strength. The amplifiers stabilize its performance around the value of 1,7GHz.

The IP camera records the disturbances in the following frequencies:

- 250 - 276MHz
- 404 - 866,3MHz,
- 1,535 - 2.7GHz.

The frequency ranges are similar to those of the previous measurement. The differences are only in the end values of ranges and a new frequency range. The equipment gave notice the most intense warning in the frequencies:

- 444,7MHz,
- 651,2MHz,
- 716,3MHz.

Conclusions

The paper describes the current state of the electromagnetic susceptibility of IP cameras (Vivotek FD8136B F3). The results were as expected because every electrical and electronic product must be subjected to tests of electromagnetic compatibility prior to marketing. An interesting fact is that the device indicates a fault condition at certain frequencies. The "disturbances" are frequency dependent because they occur only in some frequencies. These frequencies have similar initial and end frequency; however, the changes of distance (reducing) between the antenna and the EUT increase the frequency range of the technical fault. The frequencies at which the device indicates the most intensive warning have the electric field strength of 10V/m. Other field strengths do not cause such a sensitive warning. The enumeration the length between EUT and the source of interference can be obtained on the base of measured values. The distances are smaller than is required in these cases.

The work was funded with the support of the Internal Grant Agency of Tomas Bata University under the project No. IGA/FAI/2015/043, and support of research project NPU I No. MSMT-7778/2014 by the Ministry of Education of the Czech Republic.

Authors. Ing. Stanislav Kovář, Tomas Bata University in Zlín, Faculty of Applied Informatics, Nad Stráněmi 4511, 760 05 Zlín, Czech Republic, E-mail: skovar@fai.utb.cz
Ing. Jan Valouch, Ph.D., Tomas Bata University in Zlín, Faculty of Applied Informatics, Nad Stráněmi 4511, 760 05 Zlín, Czech Republic, E-mail: valouch@fai.utb.cz
Assoc. Prof. Mgr. Milan Adámek, Ph.D., Tomas Bata University in Zlín, Faculty of Applied Informatics, Nad Stráněmi 4511, 760 05 Zlín, Czech Republic, E-mail: adamek@fai.utb.cz.

REFERENCES

- [1] SVAČINA, Jiří. *Electromagnetic compatibility: principles and notes*. Issue No. 1. Brno: University of Technology, 2001, 156 p. ISBN 8021418737. (in Czech)
- [2] Encyclopedia electromagnetic compatibility [online]. 2009 [cit. 2015-04-27]. Available at: <http://www.radio.feec.vutbr.cz/emc/>. (in Czech)
- [3] KOVÁŘ, Stanislav, Jan VALOUCH, Hana URBANČOKOVÁ and Milan ADÁMEK. Electromagnetic interference of CCTV. In: *The International Conference on Information and Digital Technologies 2015*. Slovakia, Žilina, 2015. p. 161-166. ISBN 978-1-4673-7185-8. 6 p.
- [4] System on a Chip (SoC) Information. IHS Engineering360 - Engineering Search & Industrial Supplier Catalogs [online]. ©2015 [cit. 2015-07-20]. Available at: http://www.globalspec.com/learnmore/semiconductors/programmable_logic/system_on_a_chip.
- [5] ČSN EN 50130-4. *Alarm systems. Part 4, Electromagnetic compatibility - Product family standard: Immunity requirements for components of fire, intruder, hold up, CCTV, access control and social alarm systems*. Prag: Czech office for standards, metrology and testing, 2012. (in Czech).
- [6] KOVÁČ, D., KOVÁČOVÁ, I., KAŇUCH, J. *EMC in terms of theory and application*. Issue No. 1. Prag: BEN, 2006. ISBN 80-7300-202-7. 216 p.
- [7] OTT, Henry. *Electromagnetic Compatibility*. USA, Hoboken: WILEY, 2009. ISBN 978-0-470-18930-6. 844 p.