



ELSEVIER



CrossMark

Available online at [www.sciencedirect.com](http://www.sciencedirect.com)**ScienceDirect**

Procedia Engineering 100 (2015) 408 – 417

**Procedia  
Engineering**[www.elsevier.com/locate/procedia](http://www.elsevier.com/locate/procedia)25th DAAAM International Symposium on Intelligent Manufacturing and Automation, DAAAM  
2014

## Automatic Contactless Measurement of Tyre Circumference in Industrial Conditions

Milan Navrátil\*, Jakub Zdražil

*Faculty of applied informatics, Tomas Bata University in Zlin, Nad Stráněmi 4511, Zlin 76005, Czech Republic*

---

### Abstract

This work deals with complete proposal and project execution of automatic contactless measurements of a crude tyre circumference in industrial production. Complex hardware design as well as creation of user application in system CotrolWeb are described. Accomplished measurement and data analysis are also presented.

© 2015 The Authors. Published by Elsevier Ltd. This is an open access article under the CC BY-NC-ND license

(<http://creativecommons.org/licenses/by-nc-nd/4.0/>).

Peer-review under responsibility of DAAAM International Vienna

*Keywords:* contactless measurement; circumference; tyre; automation; optimization

---

### 1. Introduction

Production of tires in industrial environment is a complex process which brings a lot of requirements on quality of products. It begins by choice of raw material, preparation of rubber compounds and their technological processing as a few parallel operations. There is also a need to produce a rubberized steel cord, tread, sidewall, heel rope and impact ply. As a result of confection part of tyre processing, where the mentioned components are met, the crude tyre is produced. During all technological processes the various types of measurement and mechanical operations including robotic manipulations are often used. One of the key operation is the stitching of a crude tyre. At the end of this process, the measurement of circumference in three defined positions on the tyre is manually accomplished by the operator. Current type of measurement involves a method where the tape meter is used. This is acceptable if the required accuracy is greater than resolution of the measurement method and also if the count is small. In average it was carried out once per work shift.

---

\* Corresponding author. Tel.: +420 57-603-5283; fax: +420-57-603-5279.

E-mail address: [navratil@fai.utb.cz](mailto:navratil@fai.utb.cz)

Main disadvantage of this method is necessity to interfere the production process which had to be interrupted. To meet the new requirements of quality management, consisting of replacement of the current measuring method for the automatic one, comprises of the design of hardware as well as software system. In literature, there are different methods for various measurements of rotating objects. For example, Pfister et al. has described the laser Doppler profile sensor with sub-micrometre resolution [1]. Another sensory measurement method is based on image processing, which uses tangent value method, proportion method and Euclidean distance method to detect tire pressure and overload and uses Tamura texture features to describe tire abrasion level [2]. Interference method using frequency sweep was described in [11] and other optical methods in [12].



Fig. 1. Current method of circumference measurement of crude tyres.

## 2. Contactless measurement of distance

In accordance of needs and requirements of the studied problem, the most suitable measuring method are to be discussed.

### 2.1. Capacitive sensors

Capacitive sensors work on the principle of non-contact measurement without retroactive effect and with semiconductor output. This technology provides measurement of conductive as well as non-conductive materials. Most of them are encountered in practice in applications of measurement (scanning of non-metallic materials, monitoring levels of liquids, solids, etc.).

The basic part of the capacitive sensor consists of an electrical capacitor with variable capacitance. This often measures not only capacity but also impedance, so the manufacturer is sometimes referred to as impedance or admittance sensor. The actual design of the sensor depends on conductivity of the medium. If we apply the sensor to the environment in which we measure the position of an electrically non-conductive material, a capacitive sensor is used where the change of the position of the media will change into dielectric.

The formula describing capacity value is as follows:

$$C = \varepsilon_0 \varepsilon_r \frac{S}{d} \quad (1)$$

Changes of capacity can be evaluated with methods such as bridge methods, resonant methods or circuit feedback loop method. Capacitive sensor, which usually has a large impedance measuring circuit is connected with the special measuring cable or electronic evaluation circuits are integrated directly in the sensor head. The sensor is therefore able to remotely transmit analog or digital signals for further processing.

The problem of this type of sensor is a very bad resistance to interferences, for example, electro-magnetic alternating fields generated by fluorescent lamps, magnetic valves, radio transmitters etc. Another spurious influences can be caused by changes in temperature, humidity or by dust and surface dirt. Moreover, this type of sensors is not suitable for measuring or control of the systems with quick dynamics due to very low switching frequency.

## 2.2. Ultrasonic sensors

In general, ultrasound can be described as acoustic waves in the frequency range above the threshold of human hearing. The upper limit frequency of ultrasound is considered to be 1 GHz. Ultrasonic sensors work on the principle of measuring of transit time of ultrasonic waves from the transmitter through the reflection from the target back to the receiver. The formula describing relation between frequency and wavelength is as follows:

$$c = \lambda f \quad (2)$$

From the measured time at a known velocity of wave propagation in the environment the distance is calculated. Ultrasonic sensor consists of a piezoelectric transducer, based on a piezoelectric crystal. It has specific property that if the voltage is applied, their geometrical dimensions are changed. It changes the electrical energy into mechanical one. Similarly, brought mechanical energy to the crystal is converted to the electrical energy.

The problem with the most ultrasonic sensors is the dependence of measurement results on the speed of sound. It depends on various factors ranging from temperature, pressure, humidity and pollution. The most important quantity, which in practice is necessary to compensate, is the temperature. It has the largest impact on the speed of sound. Significant source of interference can be represented by similar sensor working on the same frequency and can influence measured results. The evaluation unit then cannot distinguish the impulses. Disadvantage of this method is measuring range which is given by dead zone and the object size. On the other hand, benefit of the method rests on possibility to measure objects with various shapes, especially transparent or shine surfaces.

## 2.3. Inductive sensors

The main part of the sensor is a coil through which the high-frequency alternating current flows. This current is generated by an oscillator. The coil creates a magnetic field that leads off from the active surface of the sensor. In case of proximity of conductive object, change of magnetic field is caused due to whirling currents. As a result of this process, change of electrical impedance of the coil is processed and then provides an output signal. Changes of magnetic field can be caused not only by the object, but unfortunately, also by surrounding interferences. Proper composition of individual surrounding subjects must be considered. Measuring range of this sensor type is in order of centimeters.

## 2.4. Optoelectronic sensors

Optoelectronic sensors are among the most common types of industrial sensors, which are used in the context of automation control. Principle of the method is the conversion of electrical energy into electromagnetic waves (light) and vice versa.

Using light for the distance measurement is conditioned by the reflection of the light beam from the object. Depending on the sensor application, three completely different physical principles are used - measurement using triangulation, measurement based on the phase shift and pulse propagation technique.

These principles differ not only in their physical nature, but also in its operational characteristics, such as the achievable resolution, repeatability and absolute accuracy of the measurement.

In industry, the most widely used type of optoelectronic sensors are based on the principle of triangulation. This method utilizes the trigonometric calculation. The laser beam is emitted from the transmitter (laser) and impacts on the measured object where it is reflected back to the receiving element of the sensor under incident angle. This angle is dependent on the distance of the measured object. The angle and intensity of the beam is then evaluated with signal processor and distance value is pass to the output of the sensor, see Fig. 2.

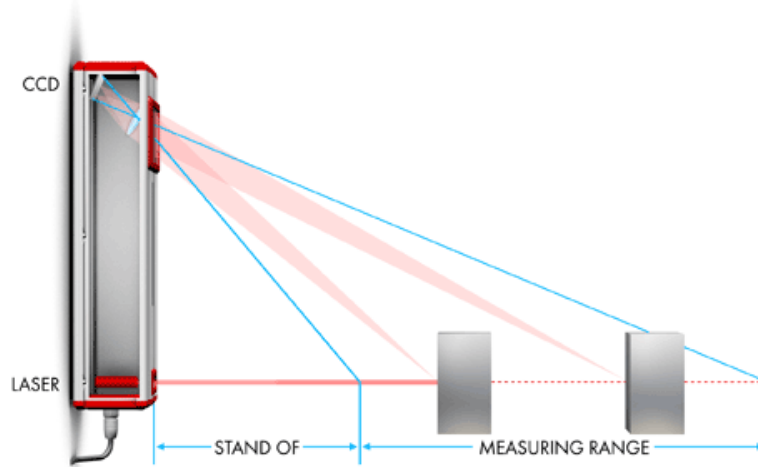

Fig. 2. Triangulation measuring method [3].

From the interferences point of view, circumjacent light sources are the most significant obstacles. Their radiation causes rise of photocurrent with small amount of DC and AC component and this can be much larger than useful signal. Measurement problems can also be induced by vapor phase, polluted ambience or temperature fluctuation [4]. Dorsch et al. have discussed in detail the uncertainty limit in distance sensing by laser triangulation [5].

### 3. Hardware design

#### 3.1. Choice and placement of the sensor

According to previous chapter, where a few measuring methods for non-contactless distance measurement are presented. Some of them are more precise than the other, some are unsuitable for the given conditions, they also differ in price etc. In our case, the most proper technique is represented by the optoelectronic sensor based on triangulation method. According to specific conditions in company, the sensor OD2-P250W150I0 from Sick producer was chosen. Its time response is up to 50 millisecond and reproducibility is 225  $\mu\text{m}$ . Signal output is represented by current in range of 4 up to 20 mA [6].

Proper placement of the sensor is very important from many points of view. If we focus on independence of revolution axis with respect to the sensor, it is necessary to use multiple sensors. Let us have two identical sensors that are pointed to each other through rotating measured object, see Fig. 3 left. The distance between sensors is known and equal to  $k$ . It is obtained by measurement on calibration standard of known length. Measured distances  $s_1$  and  $s_2$  together with constant value  $k$  provide the diameter of the measured object  $d$ .

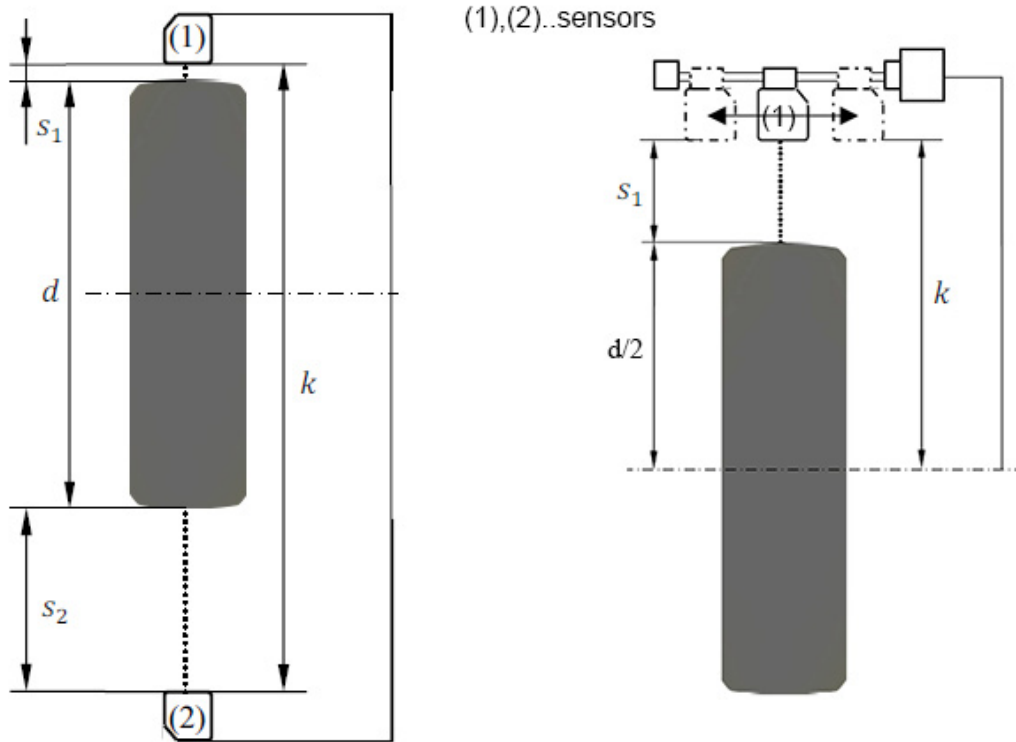

Fig. 3. Bifacial placement of sensors (left) vs one-sided placement - difference is in dependence on vertical position of revolution axis.

The circumference for bifacial placement can be calculated as follows:

$$\text{circumference} = \pi [k - (s_1 + s_2)] \quad (3)$$

If we consider use of only one single sensor, see Fig. 3 right, where constant  $k$  means the distance between the sensor and the revolution axis, we can calculate the circumference as follows:

$$\text{circumference} = 2\pi(k - s_1) \quad (4)$$

From the practical and economical point of view, we neglected the changes in vertical position of revolution axes and the one-sided sensor was chosen. Moreover, directives of production process desire circumference measurement in three different positions within the tyre width.

### 3.2. Portal axis

For positioning of the sensor the linear portal axis with toothed belt drive PAS41BR from Berger Lahr was chosen. The portal axis has a maximum stroke of 300 mm. It has two inductive sensors at the end positions. Drive of the portal axis is provided by the stepper motor ILS1M572PB1A0 in a compact design. It is controlled with digital inputs and outputs [7].

Whole system design of mentioned devices is illustrated in Fig. 4.

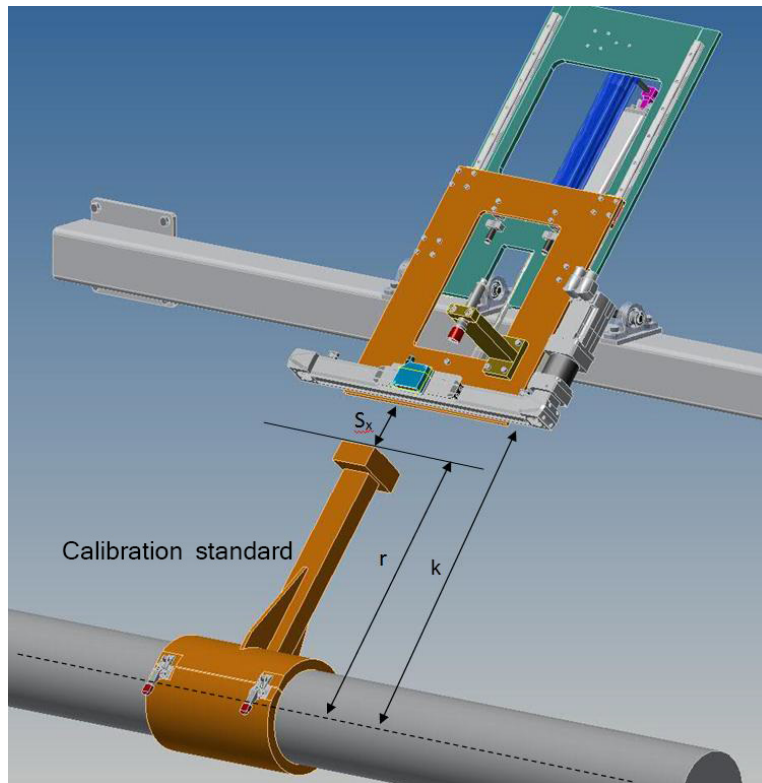

Fig. 4. Measurement on calibration standard with known reference value  $r$  in order to define of  $k$  constant.

### 3.3. Industrial PC

Industrial PC refers to computers that meet their design standards for use in industrial environments. There are increased demands on computer hardware. IPC provides increased robustness (immunity) which should counteract to shocks, increased dust, temperature, pressure, etc. Therefore these machines are made from better materials, reinforced and designed to be capable of withstanding in industrial environment. DataLab 1801A with 17" touch screen from Moravian Instruments Company was chosen [8]. It is the ideal choice for undemanding industrial applications where there is an emphasis on reliability and price rather than on large computing power. It is equipped with modern low consumption Intel Atom processor combined with the operating system Windows 7 Embedded, running from CFast memory card. Except all standard PC interfaces which are presented in DataLab PC, there are another two - RS485 and DataLab IO interface. There is also combined module of analog inputs and digital inputs/outputs DL-AD1. This module has four electrically isolated 16-bit differential analog inputs, which are used for signal processing from the sensor. The maximal sampling frequency is 50 Hz if using one channel. If using two channels, the frequency decreases to a half etc. [9]. The portal axis are controlled through RS485 interface. DataLab PC is a very versatile device and absolutely ideal platform for running Web Control system.

### 4. Software design

The application was created in Control Web 5 environment. It is based on object programming so there are many objects called instruments which are placed on the desktop and mutually interconnected via parameters [10]. Application communicates with portal axis through RS485 interface and reads the signal from sensor through analog inputs of DL-AD1 module. One digital input of the same module is used for automatized run of the measuring

process. One digital output is used for acoustic warning of failure, where three any parameters are inconvenient. The main panel is divided into three parts, the first means control and notification panel where state of devices is indicated as well as control buttons for running and stopping of the measurement, see Fig. 6.

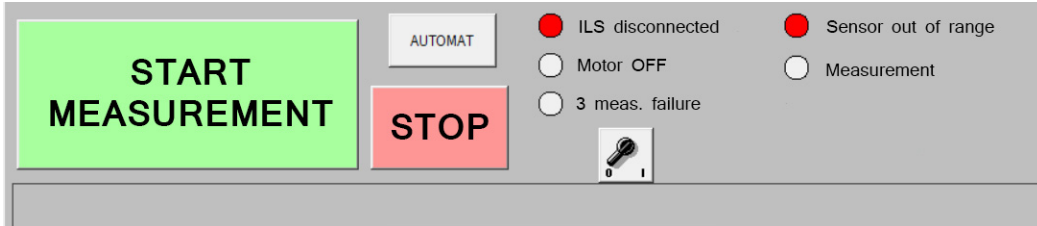

Fig. 5. Control and notification panel.

The second part of the panel shows measurement progress and results of distance and circumference values. Potential inconvenient values are indicated by red rectangle above text string with the given position. Operator inserts the directive values together with tolerances for circumference measurement, see Fig. 6. The third part of the panel contains settings of several parameters, such as number of measurement, sampling period, various constant values concerning distances and measuring positions, distance from the middle position to the lateral positions, calibration settings and many others.

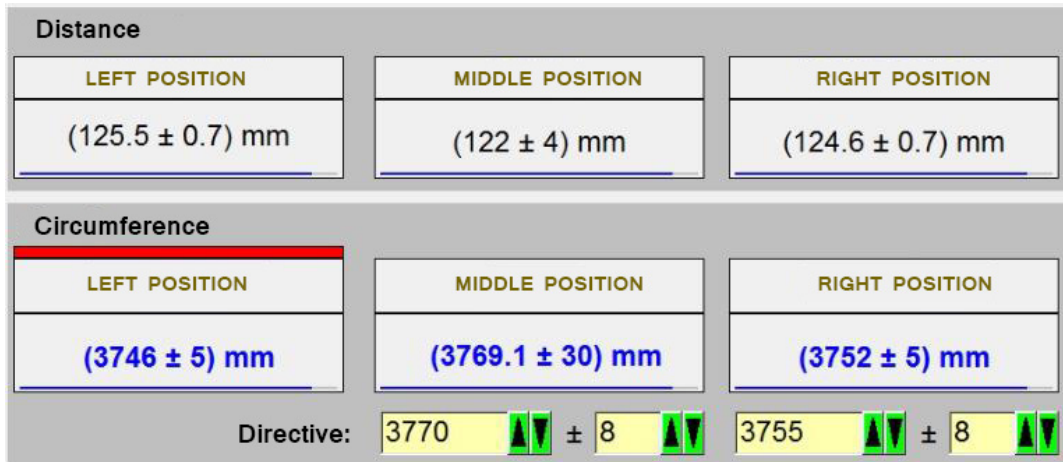

Fig. 6. Panel with measurement results and directive values.

## 5. Automatized measurement

Complete measuring cycle can be described as follows: At a specific moment of production cycle DataLab gets starting digital signal from superior production system, the crude tyre is revolving at known circumferential speed and is ready to be measured. The portal axis is ready in the middle position, according to settings the distance between tyre and sensor is N times measured, then portal axis moves the sensor to the left position and next N measurements are accomplished. The portal axis moves the sensor to the right position, etc. At the end, sensor is moved to the middle position.

Relation between circumferential speed and sampling period is crucial from the measured positions arrangement point of view, see Fig. 7.

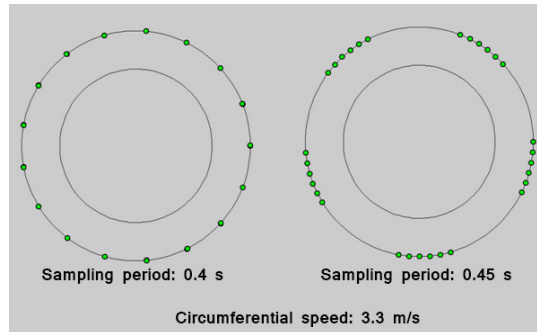

Fig. 7. Arrangement of measured positions with respect to sampling period and circumferential speed.

Obtained results from all measured positions are statistically evaluated and as a result, some characteristics are showed and saved into text file. We get mean values, median, and standard deviations.

We have accomplished many automatized and manual measurement together at different parameter settings. We have also expected that the results point us the limiting factors and allows us to make some improvements and optimization.

## 6. Results and discussion

Calculation and evaluation of the measured data as well as its graphical representation were performed in MATLAB programming environment. Through this program, we were able to clearly compare the results of the measured values from manual and automatic measurement. We focused on the statistical evaluation of mean values including extremes (values which are significantly away from average value) and also for their filtering.

Firstly, we performed measurement without any data post-processing. The circumferential speed of the rotating tyre was  $3.3 \text{ ms}^{-1}$ . Sampling period was chosen 20 milliseconds to have all measuring positions uniformly placed on whole tyre circumference. One set of measurement consists of three sub-measurement in given positions.

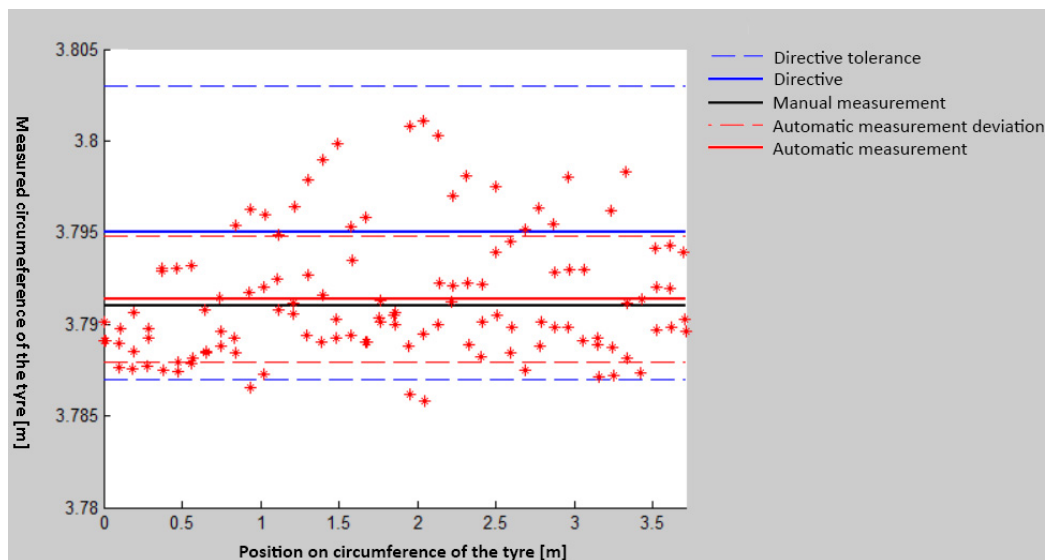

Fig. 8. Graphical illustration of measured circumference of the crude tyre in middle position.



From the statistical point of view, the more number of sub-measurement the better. Unfortunately, in our case we are mainly limited by technology and also used hardware. There is a maximal time interval when circumference measurement can be performed. During this time, our system has to manage all three sub-measurement in given positions. In Fig. 8, there is a graphical illustration of 120 measured circumferences of the crude tyre in middle position. Horizontal axis comprises positions within the circumference of the tyre. It was theoretically calculated according to slewing, based on assumption that the sampling period and tyre revolutions are kept during whole measurement process. Solid blue line represents the directive value of circumference and blue dashed line its tolerance range. Circumference value acquired by manual measurement is drawn with solid black line. Finally, results from automatic measurement are depicted in red. Individual measured values are drawn as points while mean value is represented with solid red line. Dashed red line specifies standard deviation.

If we compare mean values from automatic and manual measurement, in this case we get difference only 0.36 mm. Nevertheless, the dispersion of the values is relatively high so standard deviation is about 4 mm. To improve this situation, we decided to exclude outlying values. Measured data was arranged in descending order and thirty percent of values, fifteen from both sides, was removed from data processing (84 values were kept). The consequence of mentioned operation is depicted in pink color in Fig. 9.

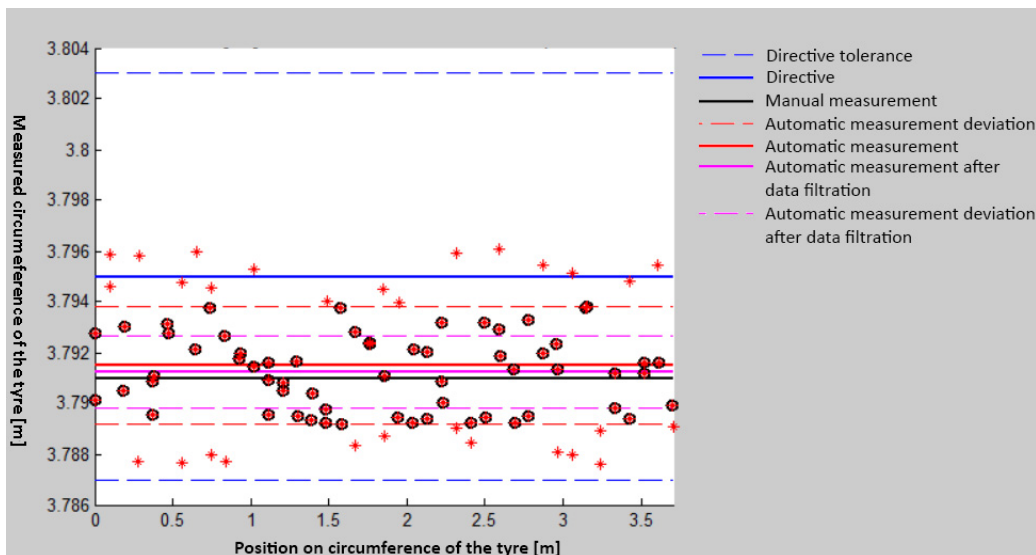

Fig. 9. Graphical illustration of measured circumference of the crude tyre with respect to its slewing, extreme values were filtered.

Standard deviation of automatized measurement decreased to the half of original value and also the mean values difference decreased. Despite mean value moved away from directive and was within the tolerance area, we are not able to claim that this is better or worse because we do not know the true value of the circumference. In this phase of the automation process, we wanted to approach to the results from manual measurement and to have stable and meaningful results. So we repeated mentioned experiment twenty times for each position and then we evaluated the data. Unfortunately, from technological reasons, we could not repeatedly measure on the same tyre. This fact deteriorated the mutual comparison of the results.

In general, from obtained results it can be said that the filtration of extreme values was a very useful tool for decreasing the standard deviation and stabilizing mean value. These fluctuations occurred during the measurement and can be caused, for example, by vibration of rotating shaft or bad reflections of the laser light from the tyre surface. Moreover, during measurement in lateral positions (very near the edge of tyre) the data dispersion was approximately three times larger than in the middle position. This is caused by shaping of the arms during stitching process which is given by technology. This behavior also influences results of manual measurement with tape meter, because in these positions, there is beveled surface of the tyre.

## Conclusion

The problem with current obsolete circumference measurement of tyres and the proposal of its automation were described in this paper. Optoelectronic sensor based on triangulation principle was chosen as a suitable device for a given industrial environment. Automatized measuring system was completed by integrating with the portal axis for positioning the sensor and both connected with industrial PC equipped with input-output modules. Control application was developed in Control Web environment and was optimized to automatically run with the output signal from the production system. One measuring cycle consisted of measurements in three defined positions along with tyre width. After this cycle was finished, obtained data were filtered to exclude extreme values and then mean value including standard deviation was shown. Data were also saved and archived into the text file. There was also indication of situations where quality requirements were not met or in case of system component failure or various error states. The method of filtration for excluding extreme and improper values were proposed and used for evaluation. Repeated measurements were performed to get some statistical outlook. The obtained results confirm the suitability of the proposed automatized system for the circumference measurement of the crude tyres in industrial measurement.

There are some suggestions which could be tried in future. The primary thing is the timing of own measurement. The better way would be measuring during one single revolution at maximum frequency. To save technological time, there is also considering of use of three distance sensors to make parallel measurement at the same moment. These improvements would lead to stabilizing the obtained results including their higher accuracy.

## Acknowledgements

The work was performed with financial support of research project NPU I No. MSMT-7778/2014 by the Ministry of Education of the Czech Republic and also by the European Regional Development Fund under the Project CEBA-Tech No. CZ.1.05/2.1.00/03.0089. Authors would also like to thank to Continental Barum Company for their support.

## References

- [1] PFISTER, T, L BÜTTNER a J CZARSKE. Laser Doppler profile sensor with sub-micrometre position resolution for velocity and absolute radius measurements of rotating objects. *Measurement Science and Technology*. 2005-03-01, vol. 16, issue 3, s. 627-641. DOI: 10.1088/0957-0233/16/3/003.
- [2] CHEN, Rong Bao, et al. Research on Methods of Tire Sensory Measurement Based on Image Processing. *Advanced Materials Research*, 2011, 230: 900-904.
- [3] Measurement Principles. LAP LASER. Metals Industries [online]. 2014 [cit. 2014-10-20]. Available at: <http://www.lap-laser.com/cz/metals-industries/products/ctg-ctfwg/measurement-principles/>
- [4] FRADEN, Jacob. Handbook of modern sensors: physics, designs, and applications. 4th ed. New York: Springer, c2010, xv, 663 p. ISBN 9781441964663-.
- [5] DORSCH, Rainer G.; HÄUSLER, Gerd; HERRMANN, Jürgen M. Laser triangulation: fundamental uncertainty in distance measurement. *Applied Optics*, 1994, 33.7: 1306-1314.
- [6] Short range distance sensors: OD2-P250W150I0. SICK: Sensor Intelligence [online]. 2014 [cit. 2014-10-20]. Available at: <https://www.mysick.com/eCatSEO.aspx?go=DataSheet&Cat=Row&At=Fa&Cult=German&ProductID=41531&Category=Produktfinder>.
- [7] PAS41BR. SCHNEIDER ELECTRIC. Main characteristics [online]. 2014 [cit. 2014-10-20]. Available at: <http://www.ops-ecat.schneider-electric.com/ecatalogue/browse.do?>
- [8] MORAVIAN INSTRUMENTS. Datalab PC [online]. 2014 [cit. 2014-10-20]. Available at: <http://www.mii.cz/cat?id=57&lang=409>
- [9] MORAVIAN INSTRUMENTS. Datalab IO modules [online]. 2014 [cit. 2014-10-20]. Available at: <http://www.mii.cz/art?id=176&cat=77&lang=409>
- [10] BÍLÝ, Radek. Control Web 2000. Vyd. 1. Praha: Computer Press, 1999, xxi, 382 s. Programování. ISBN 80-722-6258-0.
- [11] Wu, X., Wei, H., Zhang, H., Ren, L., Li, Y., Zhang, J. Absolute distance measurement using frequencysweeping heterodyne interferometer calibrated by an optical frequency comb (2013) *Applied Optics*, 52 (10), pp. 2042-2048.
- [12] Berkovic, G., Shafir, E. Optical methods for distance and displacement measurements (2012) *Advances in Optics and Photonics*, 4 (4), pp. 441-471.