



Science Arts & Métiers (SAM)

is an open access repository that collects the work of Arts et Métiers Institute of Technology researchers and makes it freely available over the web where possible.

This is an author-deposited version published in: <https://sam.ensam.eu>
Handle ID: <http://hdl.handle.net/10985/9774>

To cite this version :

Matthieu TOURON, Julien GOMAND, Jean-Yves DIEULOT, Pierre-Jean BARRE - Modeling of inertial and compliance parametric uncertainties in Port-Hamiltonian systems using LFR - In: CoDit 2013, IEEE - 2013 International Conference on Control, Decision and Information Technologies, Tunisie, 2013-05-06 - CoDit 2013, IEEE - 2013 - 2013

Any correspondence concerning this service should be sent to the repository

Administrator : archiveouverte@ensam.eu



Modeling of inertial and compliance parametric uncertainties in Port-Hamiltonian systems using LFR

Matthieu Touron, Julien Gomand, Pierre-Jean Barre
Arts et Metiers ParisTech ; CNRS, LSIS, 13617
Aix-en-Provence, France
matthieu.touron@ensam.eu

Jean-Yves Dieulot
LAGIS UMR 8219, Polytech-Lille, Cite Scientifique, 59650
Villeneuve d'Ascq, France

Abstract—This paper presents a Linear Fractional Representation of a Port Hamiltonian System for which uncertainties are concentrated on the Hamiltonian parameters. A basic block-diagram is provided and an illustration is shown on a hand-held cutting tool viewed as an effort multiplier.

Keywords—Linear Fractional Representation, Uncertainties, Port-Hamiltonian Systems, Mechanical devices

I. INTRODUCTION

Modeling physical systems for control refers to many expert disciplines linked to each physical domain (e.g. mechanics, rheology, electrical engineering ...). A global dynamical model of a multi-physic system is obtained by coupling differential equations issued from each physical field. A mathematical model such as state representation is widely used to define a control loop, but physical meaning could be lost thus no reuse of the model is possible.

In order to keep the physical semantic, a modeling method commonly used is to adopt an energetic point of view. In case of lumped parameters, a widely used formalism to express the inner interactions in a graphical approach of a system is Bond Graph. Based on the tetrahedron of state (see e.g. [9]) decomposition of complex dynamical behavior of a component, this representation bonds each elementary behavior element in a power exchange structure. Bond Graph can be used to analyze some structural properties. Furthermore, inner interactions of a system are important to settle a control structure.

In order to obtain an analytical representation of the multi-physic behavior, Port-Hamiltonian system formalism has the advantage to content the (dynamical or statical) constitutive equations associated with each lumped parameter and the inner power exchange structure (see e.g. [4] and references therein). Thus, a Input-State-Output representation of Port-Hamiltonian system (**ISO-PH**) can be obtained from a Bond-Graph representation [1,2].

A wide class of problems addresses uncertainties on lumped parameters that cannot be neglected. These parametric uncertainties can be isolated in a specific representation called Linear Fractional Representation (see e.g. [7]). The way to find a LFR from a Bond Graph representation is tackled in [3].

Uncertainties in port-Hamiltonian systems can be used in the passivity-based control framework (see e.g. [5]), or in the mu-analysis framework (see e.g. [8]).

In order to develop robust tools in a Hamiltonian formalism, our goal is to propose a formulation of parametric uncertainties on energy storage parameters for Port-Hamiltonian systems, and in particular by a linear fractional representation (**LFR**). The physical meaning of this formulation will also be presented.

First, linear PH systems and LFR representation will be recalled, and then, some results are given for a class of uncertain PH systems. An application to a hand held cutting tool is given in the last section.

II. LINEAR PORT-HAMILTONIAN SYSTEMS

Most mechanical nonlinear and linear systems can be expressed in an energetic framework, using the Hamiltonian (see e.g. [4]):

$$H = \frac{1}{2} \frac{p^2}{I} + \frac{1}{2} \frac{q^2}{C}, \quad (1)$$

where:

q : generalized coordinates,

p : generalized momenta,

H : generalized potential or Hamiltonian, sum of kinetic and potential energies.

Hamilton Canonical equations yield:

$$\begin{aligned} \dot{q} &= \frac{\partial H}{\partial p}, \\ \dot{p} &= -\frac{\partial H}{\partial q}. \end{aligned} \quad (2)$$

Introducing the local coordinates x one can rewrite:

$$H = \frac{1}{2} x^T \cdot Q \cdot x, \quad (3)$$

with

- $x = \{x_I, x_C\}$ is the state vector related to inertial storage (I) and potential storage (C) elements;

$$- Q = \begin{bmatrix} 1/I & 0 \\ 0 & 1/C \end{bmatrix}.$$

The energy balance with a power injection (u, y) at the ports of the system is as follows:

$$\frac{dH}{dt} = u \cdot y, \quad (4)$$

where: u is the action variable and y is the reaction variable of the power exchange.

Considering a network topology defined by a Dirac structure and a dissipation structure, then, introducing the interconnection structure matrix J , the dissipation matrix R and the modulation matrix g , leads to the standard ISO-PH formulation:

$$\begin{aligned} \dot{x} &= (J - R) \cdot \frac{\partial H}{\partial x} + g \cdot u, \\ y &= g^T \cdot \frac{\partial H}{\partial x}. \end{aligned} \quad (5)$$

where the multiplicative part of the constitutive equations is obtained from (3):

$$\frac{\partial H}{\partial x} = \nabla H = Q \cdot x. \quad (6)$$

III. PARAMETRIC UNCERTAINTY MODELING

One can consider many representations of parametric uncertainties, such as additive uncertainties on the state space matrices. However, multiplicative and additive uncertainties (e.g. $[A + \Delta A] \dots$) do not enable to isolate the uncertain parameters which can be a drawback when addressing the robust control aspect. Another possibility consists in considering the so-called Linear Fractional Representation (LFR) which is the main topic of this paper. A standard interconnection model, based on linear fractional representation is given (Fig. 1):

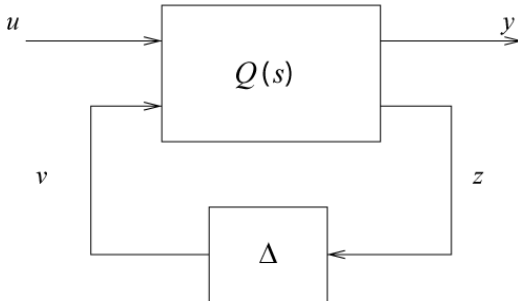

Figure 1. Linear Fractional Representation

$$Q: \begin{cases} \dot{x} = Ax + B_1 v + B_2 u \\ z = C_1 x + D_{11} v + D_{12} u \\ y = C_2 x + D_{21} v + D_{22} u \end{cases} \quad (7)$$

$$v = \Delta(\theta) \cdot z$$

This latter representation combines the deterministic dynamical behavior Q of the system, and the uncertain static equations represented in Δ . This specific formulation is used for robust μ -analysis.

Δ may be used to represent unstructured, structured and parametric uncertainties. Still, parametric uncertainty on a parameter q can be expressed in an additive form, or in a multiplicative form :

$$\begin{aligned} q &= q_n + \Delta q \\ q &= q_n(1 + \delta_q) \end{aligned} \quad (8)$$

It has been shown that an additive expression of a parametric uncertainty leads to the Uncertain State Representation, which is however not the goal of this paper.

Considering multiplicative uncertainties, a method has been proposed to determine the LFR (i.e. equations Q and equation Δ with uncertain parameters) associated with an uncertain Bond Graph (see e.g. [3]).

In this case, Δ is diagonal and:

$$\Delta: v = \Delta \cdot z \quad (9)$$

IV. A SIMPLE LFR REPRESENTATION WITH DIAGONAL UNCERTAIN MATRICES

A. Objectives

The idea is not to provide such complicated expressions as in ([1] and [3]). The aim is to propose a LFR of an uncertain Port-Hamiltonian system from a Port-Hamiltonian expression for a very specific case, however, frequently encountered with real systems, i.e. uncertainties on the lumped energy storage parameters. (Q is diagonal).

B. Uncertainties in a multiplicative form

Multiplicative uncertainties on energy storage parameters I and C will appear in the Q matrix of constitutive equations, when:

$$- Q = \begin{bmatrix} 1/I & 0 \\ 0 & 1/C \end{bmatrix}$$

and

$$\begin{aligned} I &= I_n(1 + \delta_I) \\ C &= C_n(1 + \delta_C) \\ q &= \frac{1}{I} = q_n(1 + \delta_q). \end{aligned} \quad (10)$$

From above, one has $(1 + \delta_q) = \frac{1}{(1 + \delta_l)}$, then $\delta_q = -\frac{\delta_l}{1 + \delta_l}$.

Conversely, the same approach can be used for an uncertainty on the C-element. In the same way, $\delta_q = -\frac{\delta_c}{1 + \delta_c}$.

The constitutive matrix is now defined by:

$$Q = Q_n(1 + \delta_Q), \quad (11)$$

with Q_n being the diagonal nominal parameter matrix and δ_Q the diagonal relative uncertainty matrix on Q_n .

Replacing Q defined as (11) in (5) and (6) yields:

$$\begin{cases} \dot{x} = J \cdot Q_n \cdot x + J \cdot Q_n \cdot \delta_Q \cdot x + g \cdot u \\ y = g^T \cdot Q_n \cdot x + g^T \cdot Q_n \cdot \delta_Q \cdot x. \end{cases} \quad (12)$$

Introducing: $z_n = Q_n \cdot x$ and $\Delta z = \delta_Q \cdot z$,

$$\begin{cases} \dot{x} = J \cdot Q_n \cdot x + J \cdot \Delta z + g \cdot u \\ z_n = Q_n \cdot x \\ y = g^T \cdot Q_n \cdot x + g^T \cdot \Delta z. \end{cases} \quad (13)$$

Equations (13) describes the LFR of uncertainties as necessary in (7), where (noting $\Delta z = v$) the equivalence between the two framework is :

$$\left\{ \begin{array}{l} B_1 = J \\ D_{21} = g \\ A = J \cdot Q \\ B_2 = g \\ C_1 = Q_n \\ C_2 = g^T \\ D_{21} = g^T \\ D_{11} = D_{12} = D_{22} = 0 \end{array} \right. \quad (14)$$

C. Physical interpretation :

The ISO-PH formulation corresponds to a state space representation (to manage easily a simulation or control law synthesis). As conditioned in such a way, it can be represented as a block diagram, where each matrix corresponds to a block transformation of a physical variable toward another physical variable. In this case, each power bond will be represented by two signals link of opposite orientation, one for the flow variable, the other for the effort variable.

As causality is already assigned, the block diagram associated with the nominal ISO-PH system (5) can be represented in Fig 2, using following notation:

- u : the action variable in external power exchange;
- c : the action variable for an inner energy storage:
 $c = u + c_Q + c_R = u + J \cdot z + R \cdot z$;
- z : the reaction variable for an inner energy storage:
 $z = Q \cdot x$;
- y : the reaction variable in external power exchange:
 $y = g^T \cdot z$.

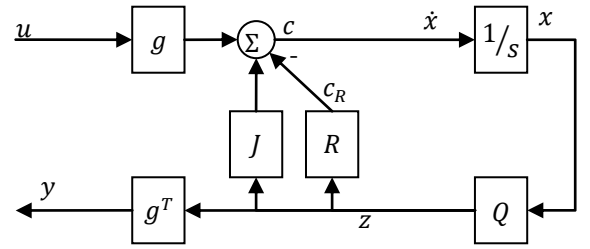

Figure 2. Block diagram of the nominal PH system

From (13) the PH system with a multiplicative uncertainty Δ_Q is shown in Fig. 3.

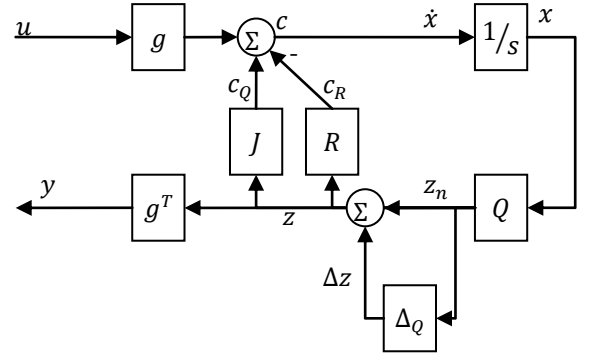

Figure 3. Block diagram of the PH system with multiplicative uncertainties

Δz appears as the uncertainty caused by δ_Q on variable z , i.e. the real value of z which can be rewritten :

$$z = z_n + \Delta z, \quad (15)$$

where z_n is the value obtained by the deterministic part of the model, and Δz is the model error on z due to uncertainty on Q . Homogenous with z , Δz is summed with z_n to obtain along with z the real output of the constitutive equations of Q . Then, this effect is injected in the inner structure through J , R , and g .

Finally, the LFR of both the deterministic and uncertain models is shown in Fig. 4, where Q^g is the augmented Q matrix :

$$Q^g = \begin{bmatrix} Q & 1 \\ 1 & 0 \end{bmatrix}. \quad (16)$$

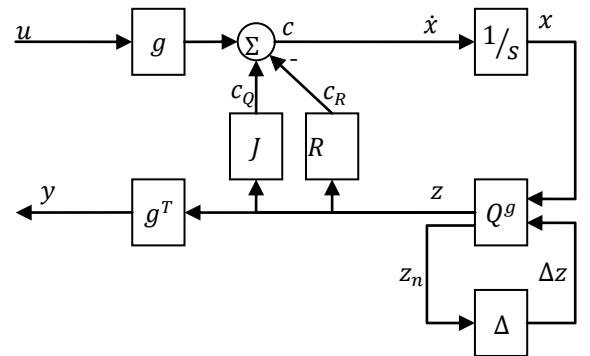

Figure 4. Block diagram of the PH system with multiplicative uncertainties in a LFR framework

V. ELECTRICAL-AIDED SCISSORS VIEWED AS A HUMAN EFFORT MULTIPLIER

To illustrate the methodology, a multi-physic system interacting with several power sources has been chosen. The autonomous hand-held cutting tool presented Fig. 5 is an operator assistance device, where the worker's muscular effort is multiplied by an internal electrical power source to act on a sample to be cut. The goal consists in cutting vineyard branches with a limited stress on muscles, thus avoiding further medical troubles. Some manipulators with interaction with the environment can be found e.g. in [6] where a Generalized Maxwell model is proposed for the material aspect. In this paper, only the global cutting force is considered.



Figure 5. Sketch of the hand-held cutting device

The interaction with the user is realized thanks to a trigger in the hand-held device, and a position sensor, the finger motion reference x_u being transmitted to the mechanism through of a spring.

Equations of the mechanism described in Fig. 6 are given with a port-Hamiltonian form in (17).

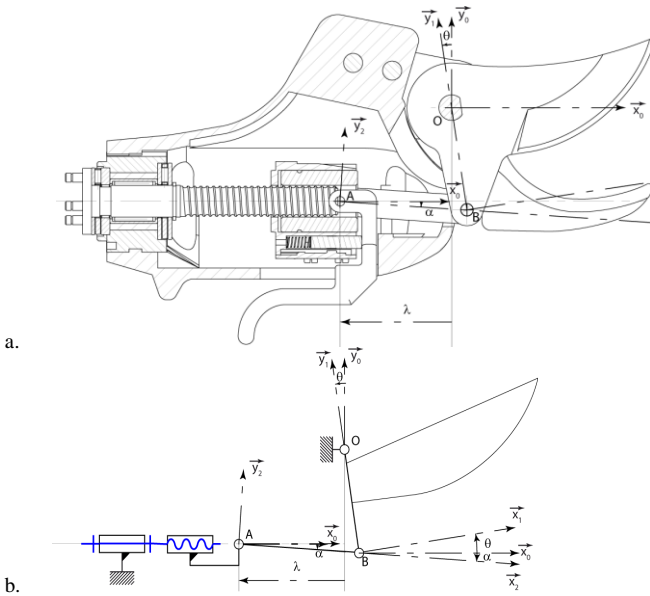

Figure 6. Design (a) and kinematics (b) of the hand-held device

The Hamiltonian can be written:

$$H = \frac{1}{2} p^2 + \frac{1}{2} K_g \Delta x^2 \quad (17)$$

where the momentum $p = I_{eq} \cdot V_e$ and V_e , λ and I_{eq} are respectively the motorized nut speed, displacement and equivalent inertia, x_u is the displacement of the trigger by the worker's finger, $\Delta x = \lambda - x_u$ the spring elongation, K_g is the spring stiffness, and F_v is the effort on the nut due to motor torque, and F_c is the cutting effort. One can write:

$$\begin{cases} \dot{p} \\ \Delta x \end{cases} = \begin{bmatrix} 0 & -1 \\ 1 & 0 \end{bmatrix} \begin{bmatrix} \frac{1}{I_{eq}} & 0 \\ 0 & K_g \end{bmatrix} \begin{cases} p \\ \Delta x \end{cases} + \begin{bmatrix} 1 & 1 & 0 \\ 0 & 0 & -1 \end{bmatrix} \begin{cases} F_v \\ F_c \\ x_u \end{cases}, \quad (18)$$

$$\begin{cases} V_v \\ V_c \\ F_u \end{cases} = \begin{bmatrix} 1 & 0 \\ 1 & 0 \\ 0 & -1 \end{bmatrix} \begin{bmatrix} \frac{1}{I_{eq}} & 0 \\ 0 & K_g \end{bmatrix} \begin{cases} p \\ \Delta x \end{cases}.$$

Coupling the mechanism equations (18) through a reducer (K_r) and a screw (P_v) driving the nut with a PM motor, are introduced L the motor inductance, r its resistance, K_m the electro-mechanical conversion coefficient, and u_{com} the command voltage yields the ISO-PH form (19) where x is the state vector.

$$\begin{cases} \dot{p} \\ \Delta x \\ \phi \end{cases} = (J - R) \cdot Q \begin{cases} p \\ \Delta x \\ \phi \end{cases} + g \cdot \begin{cases} F_c \\ x_u \\ u_{com} \end{cases}, \quad (19)$$

$$\begin{cases} V_c \\ F_u \\ i \end{cases} = g^T \cdot Q \begin{cases} p \\ \Delta x \\ \phi \end{cases}.$$

where :

$$J = \begin{bmatrix} 0 & -1 & \frac{K_m}{K_r \cdot P_v} \\ \frac{1}{K_r \cdot P_v} & 0 & 0 \\ -\frac{K_m}{K_r \cdot P_v} & 0 & 0 \end{bmatrix}, R = \begin{bmatrix} f & 0 & 0 \\ 0 & 0 & 0 \\ 0 & 0 & r \end{bmatrix},$$

$$Q = \begin{bmatrix} \frac{1}{I_{eq}} & 0 & 0 \\ 0 & K_g & 0 \\ 0 & 0 & \frac{1}{L} \end{bmatrix}, \text{ and } g = \begin{bmatrix} 1 & 0 & 0 \\ 0 & -1 & 0 \\ 0 & 0 & 1 \end{bmatrix}.$$

Two models are introduced, one representing the real behavior of the system, another modeling by an LFR approach, where Δ is perfectly known, so that the numerical equation $Q = Q_n + \delta Q$ is verified.

Δ is chosen identically zero except for its first diagonal term, i.e. an uncertainty is introduced on I_{eq} . A simulation is led. As shown beforehand, the two models are equivalent. This leads to an identical vector x for the two models.

The time evolution of the three components (V_c, F_u, i) of vector z is given in Fig. 7, for both the realistic model, and z_n and Δz for the LFR model. It can thus be verified that $z = z_n + \Delta z$ for the first component. As no uncertainty has been introduced on the two other components, simulation shows $\Delta z = 0$.

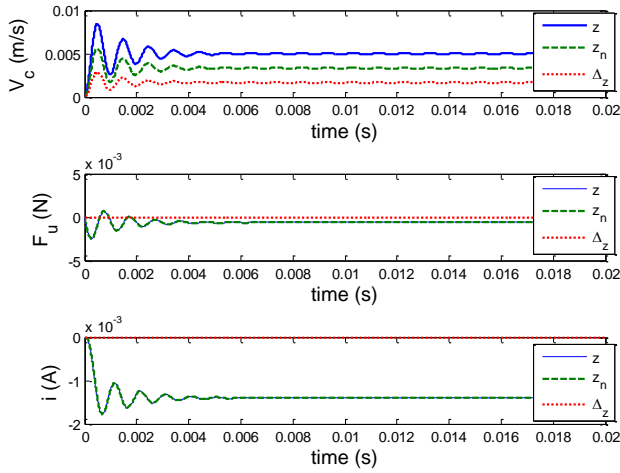

Figure 7. Simulations of the autonomous electrical scissors

VI. CONCLUSION

In this paper, it has been shown how uncertainties on energy storage elements can be modeled from a Port-Hamiltonian model. Those can be isolated from the deterministic behavior through the Linear Fractional Representation framework.

Furthermore, a physical interpretation of the interconnection between a nominal model and its uncertainties matrix has been proposed, showing that the action of Δ is a tuning on some physical variables whose effects can be followed through the inner power structure.

Finally, the methodology was illustrated on a multi-physic multi-power-source system, illustrating the validity of the LFR

method to model uncertainty on Hamiltonian lumped parameters.

Next steps aim at introducing, without a complicated generalization, further uncertainties on the junction (J) and dissipation (R) matrices, and using the resulting representation for control synthesis.

REFERENCES

- [1] A. Donaire, S. Junco, Energy shaping, interconnection and damping assignment, and integral control in the bond graph domain, *Simulation Modelling Practice and Theory*, Volume 17, 2009, Pages 152-174
- [2] A. Donaire, S. Junco, Derivation of Input-State-Output Port-Hamiltonian Systems from bond graphs, *Simulation Modelling Practice and Theory*, Volume 17, 2009, Pages 137-151.
- [3] C. Sié Kam, G. Dauphin-Tanguy, Bond graph models of structured parameter uncertainties, *Journal of the Franklin Institute*, Volume 342, 2005, Pages 379-399
- [4] Dòria-Cerezo, A., 2006. Modeling, Simulation and Control of a Doubly-Fed Induction Machine Controlled by a Backto-Back Converter. PhD Thesis, Technical University of Catalonia, Spain.
- [5] D.A. Dirksz, J.M.A. Scherpen, Adaptive tracking control of fully actuated port-Hamiltonian mechanical systems, 49th IEEE Conference on Decision and Control, December 15-17, 2010, Hilton Atlanta Hotel, Atlanta, GA, USA
- [6] D. Navarro-Alarcon, P. Li, H. M. Yip, Energy Shaping Control for Robot Manipulators in Explicit Force, Regulation Tasks with Elastic Environments, 2011 IEEE/RSJ International Conference on Intelligent Robots and Systems, September 25-30, 2011. San Francisco, CA, USA
- [7] J. Doyle, A. Packard, K. Zhou, Review of LFTs, LMIs, and mu, *Proceedings of the 30th Conference on Decision and Control*, Brighton, England, 1991.
- [8] S. Mei, T. Shen, W. Hu, Q. Lu, L. Sun, Robust H(infinity) control of a Hamiltonian system with uncertainty and its application to a multi-machine power system, *IEE Proceedings Control Theory and Applications*, Volume 152, 2005, Pages 202-210.
- [9] D.C. Karnopp, D.L. Margolis, R.C. Rosenberg. *System Dynamics - Modeling and Simulation of Mechatronic Systems*. John Wiley & Sons Inc., Fourth edition, 2005.