

Effect Of Number Of Laser Scans On The Corrosion Behavior Of Laser Formed Titanium Alloy

Esther T. Akinlabi *Member, IAENG*, and Stephen A. Akinlabi *Member, IAENG*

Abstract—This paper reports the investigation conducted on the corrosion behavior of laser formed Titanium alloy (Ti6Al4V). The Titanium alloy sample strips of $1 \times 90 \times 30 \text{ mm}^3$ were laser formed with the following process parameters; laser power (800 W), beam diameter (12 mm) and scanning speed (0.03 m/min) and the number of scans were varied between 3 to 7. The laser formed samples were characterised through the microstructure, hardness and the corrosion behaviour. The visual inspection conducted on the laser formed samples revealed a de-colouration on the samples mostly along the laser tracks. The microstructural evaluation and the grain size measurements were conducted to establish the evolution of the properties of the formed samples. The microstructure of the formed sample was observed to be martensitic in nature compared to the equiaxed microstructure observed in the as-received material. Furthermore, microcracks were also observed in the heat-affected zone. The microcracks observed on the surface of the formed samples revealed that the length of the cracks increases with the number of laser scans. The grain sizes were observed to decrease with the increasing number of laser scans. It was observed that as the number of laser scans increases, the corrosion properties became enhanced.

Keywords—Corrosion, laser forming, micro cracks, microstructure.

I. INTRODUCTION

Forming has traditionally been the manufacturing process for shaping metallic samples by using dies and presses with external force. The metal forming process among other manufacturing processes, such as casting, machining, joining, laser sintering, electronic beam melting and such are considered to be manufacturing processes. These processes uniquely change the properties of materials during the process of converting the stock or raw materials into finished or semi-finished products for different application purposes in both the domestic and industrial sectors. The changes observed in the properties of the formed samples or part result from the plastic deformation of the solid samples. During this process, both the mass and the material structures are maintained. Metal forming applications have been successful in many industrial applications such as in the automotive industry, the aerospace,

ship building and other construction applications [1]-[4]. Materials commonly formed in this way are steel, aluminium and titanium sheets. In the automotive and aerospace industries, stretch bending is also widely used to form aluminium boat hulls and architectural shapes from sheet metals [5]-[8].

Laser Forming (LF), on the other hand, is a non-contact process, and one of the new processes developed for shaping metallic samples without the use of applied force to the sample. This process is achieved by introducing thermal stresses into the material from the irradiation of the defocused beam of a laser; and thereafter, producing the desired shape. The schematic of the laser forming process is illustrated in Fig. 1.

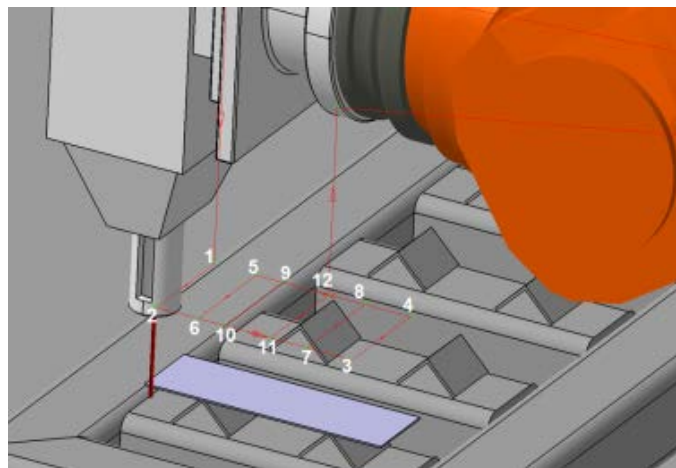

Fig. 1: schematic diagram of the laser forming process

The desired shape is governed by various parameters, such as the laser beam power, the beam diameter, the scan velocity and the number of scans. The objective of laser forming is to selectively heat areas of a workpiece in order to bring about deformation in a controlled manner by one of the bending mechanisms. The deformation of the sheets and plates can be achieved by scanning the laser beam across one side of the material. As a result, temperature gradients are developed through the material thickness, which induce stresses because of the differential expansion of adjacent layers at different temperatures.

Materials, such as steels and other light alloys; such as those of aluminium, magnesium and titanium have a high coefficient of thermal expansion. These materials significantly deform when heated with the laser beam. The temperature gradient

Dr E. T. Akinlabi: Department of Mechanical Engineering Science, University of Johannesburg, Auckland Park, Johannesburg, South Africa, 2006. (Phone: +2711-559-2137; e-mail: etakinlabi@uj.ac.za).

Mr. S. A. Akinlabi: School of Mechanical, Industrial & Aeronautical Engineering, University of the Witwatersrand, Johannesburg, Wits 2050, South Africa. (Phone: +27 11 717 7305; e-mail: Stephen.Akinlabi@wits.ac.za).

developed during the process compels the material to expand non-uniformly, which in turn leads to non-uniform thermal stresses. When the thermal stresses exceed the yield point of the material, plastic deformation result [9]-[14].

In addition, empirical evidence suggests laser forming as a viable process for the production of sheet metal prototypes; it is free of springback; and it is a non-contact process [13]-[15]. Furthermore, the process has demonstrated potential uses in many engineering applications, which were also not possible with other techniques. In particular, many possibilities now exist for the deployment of laser forming within production engineering for alignment and adjustment procedures, as well as for the bending of prototypes [16]-[18].

An area where laser forming is used extensively is to form titanium sheets. Titanium is a material that possesses an exceptional combination of properties. It has a high strength to weight ratio, a high melting point and possesses good corrosion resistance. Titanium is used extensively in various industries such as chemical, surgical implants, manufacturing and especially in the aerospace industry where good strength to weight ratio is required [19]. One of the unique features of titanium and its alloys is that at normal temperature, it possesses amazing corrosion resistance. It is virtually immune to air, marine and various industrial environments. However, at elevated temperatures, it reacts chemically with other materials [19]. It is important to note that the high temperatures associated with laser forming process may affect the physical, mechanical and chemical properties but most interesting in this study is the corrosion properties of laser formed titanium alloy and we need to investigate these effects. With this in mind, the aim of this study is therefore investigate the effect of the laser forming process on the corrosion behavior of Ti6Al4V Titanium alloy sheets. In addition to investigating the corrosion behavior of the laser formed titanium alloy, the effects of the laser forming process on the evolving microstructure and the SEM analysis after corrosion were investigated.

II. EXPERIMENTAL SET-UP

The laser forming of 1 mm Titanium alloy (Ti6Al4V) sheets was conducted at the Nation Laser Centre, Council for Scientific and Industrial Research (NLC-CSIR), Pretoria, South Africa, using a 4.4 kW Diode-pumped Nd: YAG laser (ROFIN DY 027 – 044 model). The dimension of the test sample was 90 x 30 x 1 mm³ and the optimised process parameters employed to form the Titanium sheets are laser power of 800 W, beam diameter of 12 mm, scan speed of 0.03 m/min while the number of laser scans was varied between 3 - 7. Argon gas was used as the shielding medium because of the oxidation tendency of Titanium at elevated temperature.

All the test samples were cleaned with acetone to remove all form of oil or grease to keep it clean before the forming process.

Three set of test samples were formed with the three set of process parameters with particular interest of investigation being the effect of the number of scans on the evolving properties such as the surface appearance, the microstructure,

and the corrosion behavior. All the set of samples were physically inspected after the forming process and also characterized metallurgically to establish the microstructure. The mounted samples were etched with Kroll's reagent to reveal the metallurgical properties of the formed samples. This was observed under the optical microscope. In addition, the grains were also measured.

The corrosion behavior of both the formed and the as-received titanium sheets were subjected to electrochemical study using prepared samples of 10 x 6 mm². Electrochemical measurements were conducted using the potentiodynamic polarization technique according to ASTM standard G 3-89 and 5-94 [20]. A total of fourteen samples were subjected to the cyclic polarization test – four (4) tests per each formed samples and two (2) tests for the as-received material. The electrochemical cell consisted of a 200 ml covered PyrexTM glass conical flask suitable for the conventional three-electrode system and NaCl was used as the corrosive medium.

III RESULTS AND DISCUSSION

A. Visual inspection of the formed samples

Shown in Fig. 2 are representative samples from the formed samples. Brownish colouration was observed on the surface of the formed samples and mostly pronounced on the laser tracks. This is suspected to be the effect of the high heating on the material removing suspected oxide layer. No surface defect was visible to the eye.



Fig. 2. Typical laser formed Ti6Al4V samples

B. Microstructure

The microstructure of the as-received revealed the alpha (light areas) and the beta structure (darker areas) and is shown in Fig. 3 however, the grain boundaries of the as-received material are difficult to distinguish as seen in the microstructure.

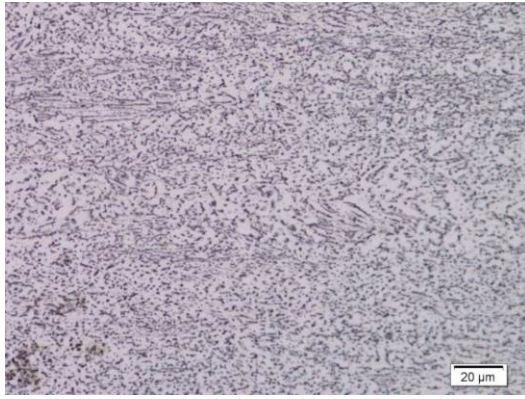

Fig. 3. Microstructure of as-received material

Typical microstructure of the formed samples is presented in Fig. 4.

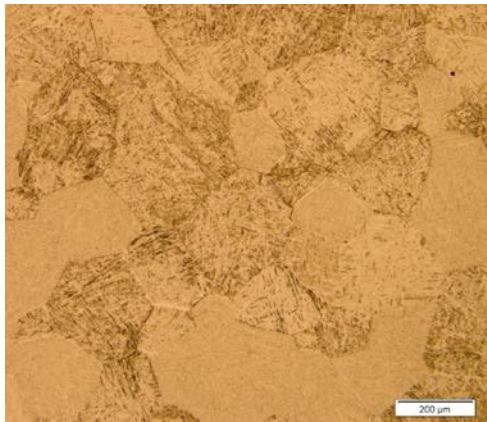

Fig. 4. Microstructure of formed sample

The microstructure revealed a martensitic structure, with a supersaturated non-equilibrium hexagonal alpha phase with acicular shapes as observed in the Figure. The grain boundaries and the structures of the alpha and beta grains are spherical in shape similar to the literature [21].

C. Grain Size measurements

The measured grain sizes of the as-received Titanium alloy was observed to be made up of equiaxed alpha phase with an average grain similar in sizes and in orientation. The grain structures were hexagonal acicular grains. Table I presents the summary of the measured average grain sizes when compared to the as-received material.

TABLE I
GRAIN SIZE MEASUREMENT COMPARED TO THE AS-RECEIVED MATERIAL

Samples	Number of scans	Average grain Size (μm)
Parent material		16.6
Formed set 1	3	400.89
Formed set 2	5	288.95
Formed set 3	7	212.59

The grain sizes were observed to increase substantially in the formed samples. This increase was attributed to the changes in the dislocation of the grain boundaries also, the initial change in the microstructure from equiaxed to martensitic α causes an increase in the grain sizes. However, once the microstructure is changed, the increase in the number of scans changes to a type of heat treatment and produces strain hardening in the material causing the grain sizes to be further reduced as the laser scans increases. Furthermore, it was observed that the grain sizes decreases with an increase in the number of laser scans.

D. Defect characterization

A surface deformation was observed in some of the formed samples in the heat affected zone but microcracks were observed on the surface of the samples. This phenomenon was observed closely only with samples formed with the five and seven laser scans and this was attributed to the possible challenges in ensuring effective cooling rate during the laser forming process. This consequently resulted to shrinkage stresses in areas of high constraints. More specifically, the microcracks were mostly observed in the area of globular β titanium alloy. A typical micrograph found on the surface of the sample formed with five laser scans is shown in Fig 5.

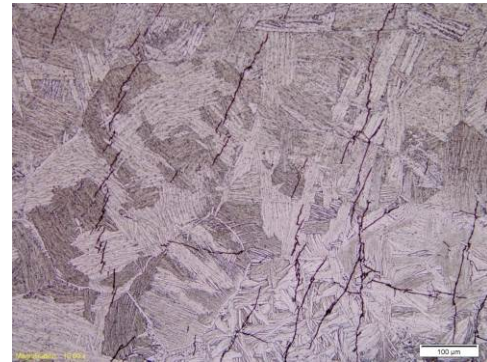

Fig. 5. Surface micrograph of formed sample with 5 laser scans

The result from the three set of formed samples showed that no microcracks were found on the sample formed with three laser scans; the microcracks observed in sample formed with five laser scan were short and jagged. Microcracks are considered dangerous for any industrial application especially when such material is subjected to fatigue loading conditions.

Such samples will have stress concentration set up at these cracks and localized yielding can occur even if the stress is below the yield strength of the material. This makes such material unsuitable in fatigue applications such as aviation industry where the factor of safety is very low and the consequence of failure is very high. As such, the number of scans needs to be optimised for typical applications.

E. Corrosion behavior

The cyclic polarization scans were conducted on the sample

to determine whether or not pitting occurs and also to determine the corrosion rate. Fig. 6 shows the set of test with the least noise for each sample. The evaluation criterion to determine whether pitting will occur in the formed sample is by identifying the direction the hysteresis loop occurs. It is important to note that the hysteresis loop can either move in a clockwise or an anti-clockwise direction with a clockwise loop indicating that pitting will occur and an anti-clockwise loop indicating resistance to pitting. From Fig. 7, the cyclic polarization graph indicates that the hysteresis loop moves in an anti-clockwise direction for all of the samples. This consequently means that the parent material, as well as the laser formed samples are resistant to pitting corrosion [21]-[22] however, general corrosion will still occur.

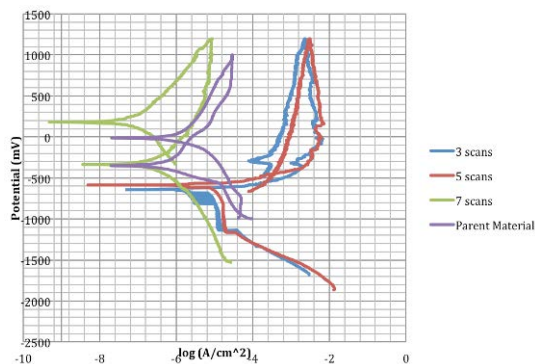

Fig. 6. Cyclic polarization graph

Furthermore, conducting the Tafel analysis was also very important in order to determine the corrosion potential and the corrosion current. The result of the Tafel analysis is summarized in Table II.

TABLE II
E_{CORR} AND I_{CORR} VALUES FOR THE SAMPLES

Sample	E _{corr} (mV)	I _{corr} (A/cm ²)	Corrosion rate (µm per yr)
Parent Material	-347.3	3.31 x 10 ⁻⁷	3.87
3 Scans	-638.6	6.3 x 10 ⁻⁶	73.66
5 scans	-582.7	6.3 x 10 ⁻⁶	73.66
7 Scans	-333.7	1.05 x 10 ⁻⁷	1.23

The corrosion potential of the sample formed with seven scans was higher with -333.7mV, the sample formed with five scans was -582.7tmV while the sample formed with three scans is 638.6mV. The shift of the corrosion potential to more noble potential for the sample formed with the seven laser scans implies lower tendency for the sample to corrode in comparison to the other samples [22]. The sample formed at seven laser scans also had the lowest corrosion current. While the corrosion resistance of the sample scanned seven times improved compared to others. The opposite was true for the

three and five scan samples [21].

The corrosion current was used to determine the corrosion rate per year using equation 1

$$CR = K_1 \frac{i_{corr}}{\rho} EW \dots\dots\dots (1)$$

Where:

- K₁ = 3.27 x 10⁻³, mm g/µA cm yr
- ρ = density in g/cm³ = 4.43g/cm³ for Ti-6Al-4V
- EW = equivalent weight = 15.84 for Ti-6Al-4V [21]
- i_{corr} = corrosion current density, µA/cm²

The results also revealed that the samples formed with three and five laser scans had the lowest resistance to corrosion and the highest corrosion rate per year. It is important to note that the samples formed with laser scan of seven had the greatest resistance to corrosion and lowest corrosion rate per year which was an improvement in corrosion properties compared to the parent material. Although, the formed sample at seven number of scans had the best corrosion resistance, it should be noted that this particular sample was characterised with microcracks. Comparing the corrosion resistances, the sample formed at three number of scans can still be considered optimum as it does not have defect in it structure and possesses good resistance to corrosion after laser forming.

F. Scanning Electron Microscopy analysis of the Corroded samples

Following the corrosion tests, the tested samples were subsequently observed under the SEM to confirm the corrosion mechanisms of the Ti6Al4V in NaCl solution. The SEM analyses of the formed samples are shown in Fig. 7.

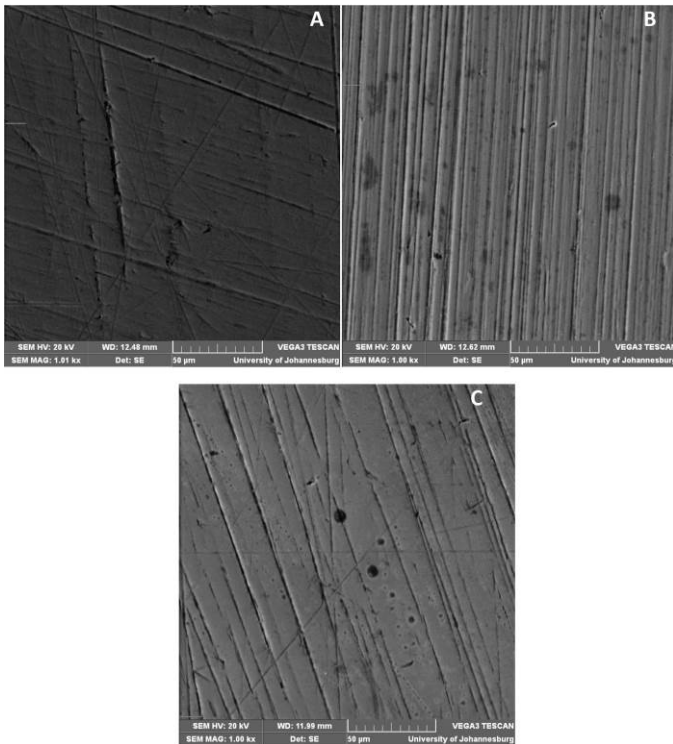

Fig. 7. SEM of the formed samples with (a) three, (b) five and (c) seven laser scans

It was observed from all the formed samples that there was no visible evidence of pits on the surface of the laser formed samples.

IV CONCLUSION

The study firstly demonstrated the successful laser forming of Ti6Al4V alloy and establishes the effect of number of laser scans on both the mechanical properties and corrosion behavior of the formed samples. This was then correlated to the resulting microstructure and the SEM micrograph of the corroded samples. The laser forming process caused a change in the microstructure of the material from equiaxed to martensitic α . The result of this change in the microstructure led to an increase in the grain sizes in the laser formed samples compared to that of the as received material. However, as the number of scans increased, the grain sizes decreases again. This led to the sample formed with seven scans had the smallest average grain size of 212 μm , followed by samples with five laser scans and that with three laser scans having an average grain sizes of 289 μm , and 401 μm respectively.

The corrosion resistance also decreased due to the laser forming process but as the number of scans increases, the corrosion properties improved. The corrosion properties of the sample formed with seven laser scans had better corrosion properties than the as-received. Seven scans would have been the optimum number of scans between the three samples as it had the most favorable characteristics between the formed samples. However, the microcracks observed on the surface of the sample formed with seven laser scans would make it unsuitable for most industrial application. Hence, the sample

formed with the three laser scans would be the optimum number of scans that can be recommended, this uniquely differentiate it from other formed samples though have other properties similar.

ACKNOWLEDGMENT

The authors wish to thank Dr Peter Olubambi and Mr Tunde Obadele of Tshwane University of Technology, Pretoria South Africa for allowing us to use their facility for the corrosion tests.

REFERENCES

- [1] L. Kurt, *Handbook of Metal Forming*. McGraw-Hill Book Company, New York, NY 10020. 1985.
- [2] M. Sistaninia, M. Sistaninia and H. Moeanodini, "Laser forming of plates using rotating and dithering beams," *Computational Material Science* 45, pp. 480-488, 2009.
- [3] C. Carey, W. J. Cantwell, G. Dearden, K. R. Edwards, S. P. Edwardson and K. G. Watkins. "Towards a rapid, non-contact shaping method for fibre metal laminates using a laser source," *International Journal of Advance manufacturing Technology*, 47:557-565. DOI 10.1007/s00170-009-229-y, 2010.
- [4] Manufacturing processes: Metal forming, 2012, [online]. Available: <http://www.tech.plym.ac.uk/sme/mfrg315/metform1.htm>, [Accessed February 18, 2013].
- [5] Sheet Metal Manufacturing Process- Stretched Forming, 2012, [online]. Available: <http://www.manufacturelink.com.au/processes/sheet-metal-stretch-forming.aspx>, [Accessed February 18, 2013].
- [6] Sheet metal forming, 2012, [online]. Available: www.customerpartnet.com/wu/sheet-metal-forming, [Accessed February 18, 2013].
- [7] S. A. Akinlabi, T. Marwala, E. T. Akinlabi and M. Shukla, "Effect of Scan Velocity on Resulting Curvatures during Laser Beam Bending of AISI 1008 Steel Plate," *Journal of Advanced material Research*, Vols. 299-300, pp. 1151-1156, 2011.
- [8] M. Safari and M. Farzin. Experimental and numerical investigation of laser bending of tailor machined blanks. *Optics & Laser Technology*, 48, 513-522, 2013.
- [9] E. Kannatey-Asibu, *Principle of laser materials processing*. John Wiley and sons, Inc., New York, N.Y., 2009.
- [10] G. Dearden and S. P. Edwardson, "Some recent development in 2 and 3 dimensional laser forming for macro and micro applications," *Journal of Optics A: pure and Applied Optics* 5, S8-S15. 2003.
- [11] L. Lawrence, M. J. J. Schmidt and L. Li, "The forming of mild Steel plates with a 2.5kW high power diode laser," *International Journal of Machine Tools and Manufacture*, 41, pp.967-977, 2001.
- [12] D. P. Shiddid, M. H. Gollo, M. Brandt and M. Mahdavian. Study of effect of process parameters on titanium sheet metal bending using Nd: YAG laser. *Journal of Optics and Laser Technology*, 2013; 47, 242-247
- [13] M. H. Gollo, S. M. Mahdavian and H. M. Naeini, "Statistical analysis of parameter effects on bend angle in laser forming process by pulsed Nd: YAG laser," *Journal of Optics & Laser Technology*, 43, pp. 475-482, 2011.
- [14] F. R. Liu, K. C. Chan and C. Y. Tang, "Numerical simulation of laser forming of aluminium matrix composites with different volume fractions of reinforcement," *Journal of Materials Science and Engineering, A* 458, pp. 48-57, 2007.
- [15] S. A. Akinlabi, T. Marwala, M. Shukla and E. T. Akinlabi, "Laser Forming of 3 mm Steel Plate and the Evolving Properties," *In the Proceedings of the International Conference on Manufacturing Engineering*, 2011, organized by the World Academy of Science, Engineering and Technology on Materials and Manufacturing (WASET).
- [16] M. Marya and G. R. Edwards, "The Laser Forming of Titanium Alloys," *5th International Conference on Trends in Welding Research, Georgia. USA. ASM International*, 1998, pp.1-6
- [17] E. T. Akinlabi, M. Shukla, and S. A. Akinlabi, "Laser Forming of Titanium and Its Alloys - An Overview," *World Academy of Science, Engineering and Technology*, no. 71, pp. 1522-1525, 2012.

- [18] Y. Shi, Z. Yao, H. Shen and J. Hu, "Research on the mechanisms of laser forming for the metal plates," *International Journal of Machine Tools and Manufacture*, 46, pp.1689–1697, 2006
- [19] W. D. Callister and D. G. Rethwisch, *Material Science and Engineering*, 8th ed. Asia: Wiley, 2011.
- [20] Standard Guide for Conducting Corrosion Coupon Tests in Field Applications. ASTM standard G 3-89 and 5-94. 2013. Accessed from databases. February, 2014.
- [21] R. M. Abou Shahba, W. A. Ghannem and A. El-Sayed El-Shenawy, "Corrosion and inhibition of Ti-6Al-4V alloy in NaCl solution," *International Journal of Electrochemical Science*, vol. 6, pp. 5499-5509, November 2011.
- [22] A. Andrews, M. Herrmann, M. Sephton, C. Machio and A. Michaelis, "Electrochemical corrosion of solid and liquid phase sintered silicon carbide in acidic and alkaline environments," *Journal of the European Ceramic Society*, vol. 27, 2007, pp. 2127-2135.