



SAIIE25 Proceedings, 9th - 11th of July 2013, Stellenbosch, South Africa © 2013 SAIIE

DESIGN OF AN AUTOMATED GRINDING MEDIA CHARGING SYSTEM FOR BALL MILLS

W.F. Rupare^{1*}, L. Nyanga², A.F. Van der Merwe², S Matope² and S Mhlanga³

¹Department of Industrial and Manufacturing Engineering
National University of Science and Technology, Zimbabwe
ruparewellington4@gmail.com

²Department of Industrial Engineering
University of Stellenbosch, South Africa
inyanga@sun.ac.za

³Department of Mechanical Engineering Sciences
University of Johannesburg, South Africa
smhlanga126@gmail.com

ABSTRACT

The parameters of mill load (ML) not only represent the load of the ball mill, but also determine the grinding production ratio (GPR) of the grinding process. Monitoring and recognition of milling conditions have significant effect on the operating efficiency, product quality, and energy and grinding media consumption for the milling circuit. This paper presents an automated grinding media charging system incorporating a multi-agent system developed in Java Agent Development Environment (JADE). A control logix program is designed to determine the precise quantities of grinding media to be charged in an incremental manner such that shock loading is avoided. The multi-agent system created in JADE monitors the power drawn and the mill load of the ball mill such that proper charging conditions are established. High quality of the regulation process is achieved through utilization of the control logix and the multi-agent system.

* Corresponding Author



1 INTRODUCTION

Grinding or milling in ball mills is an important technological process applied to reduce the size of particles which may have different nature and a wide diversity of physical, mechanical and chemical characteristics. On-line monitoring and recognition of milling conditions has significant effect on the operating efficiency, product quality, and energy and grinding media consumption for the milling circuit. The key issue of concern however is monitoring the way grinding media is being replenished over time as it is subject to excessive wear as a result of the stringent milling process. As of 2006, 0.23 billion kg of steel in the US and over 0.45 billion kg in the world were estimated to be consumed each year in wet grinding alone owing to increased grinding media consumption rates, and this is very much inconsistent with principles of Sustainable Development. The high consumption rates are primarily attributed to poor charging practices, wherein overcharging is resulting in increased wear as a result of increased and rigorous collision between grinding media itself as stated by Kotake et al [1]. The principal aim in optimisation of grinding media charging is to reduce the costs of procuring the grinding media, replacing liners inside the ball mill and electricity consumption and bills due to running over-loaded ball mills. This paper focuses on optimized grinding media charging through integration of a multi-agent system created in JADE and a control program developed in Siemens S7.

2 GRINDING MEDIA WEAR AND EFFECTS OF OVERCHARGING

Most organisations are faced with difficulties with replenishing grinding media during or after a milling operation has been performed, especially those who run continuous milling processes. In such instances grinding media is supposed to be replenished as the ball mills are running. Poor charging practices in the yesteryears have seen over charging occurring. Some of the adverse effects of overcharging are outlined below.

2.1 Excessive wear of Steel Balls (Grinding media)

Over loading has some adverse effects on the grinding media. Generally when all things are equal, the expected wear on the grinding media should be caused by the interaction of the media, water and ore, but due to over loading there is increased and rigorous collision between the media resulting in breakages and increased wear as stated by Kotake et al [1] and Zhao and Yuan [2].

2.2 Increased Mill Load

Mill load or charge volume is the cumulative sum of the grinding media, process water and ore. The grinding media constitute the bigger percentage of the mill load. Empirical information show that 40% load by volume of ball mills result in optimum operation or grinding as supported by Erdem [3], Yang & Li [4] and Bernard et al [5]. Increasing mill loads way above this value may result in mill over loads. The subsequent result or effects of overcharging is increased power consumption by the ball mills.

2.3 Increased Power Consumption

Power consumption by ball mills is directly proportional to mill load/charge volume, and specifically the amount of grinding media added at a particular time. Increased power consumption normally results in high electricity bills. Equation (1) outlines this relationship between power draw and mill load as used by Fuerstenau et al [6] and Powell et al [7].

$$\text{Power Drawn} = A \times B \times C \times L \quad (1)$$

Where:

A = factor for diameter inside the shell liners.

B = factor for mill type and charge volume (% loading).



C = factor for mill speed expressed as a percentage of mill critical speed.

L = length of grinding chamber measured between head liners at the junction of the shell and head liners.

2.4 Excessive wear of Liners

Overcharging of grinding media has also been seen to be a cause of excessive wear of liners inside ball mills. This is a cause of great concern as it has of late resulted in increase of the cost associated with replacing these liners. Dimeas & Hatziaargyriou [8] highlighted the other effect as being the increase in the frequency of changing or replacing these liners earlier than expected by the manufacturers.

2.5 Increased frequency of Over-load trips and down times

Increase in mill load as a result of overcharging grinding media has of late seen frequent trips as a result of over loads. Generally the motors driving the ball mills have a rated maximum capacity that they can power. Overcharging mills, especially running ball mills has been seen as a cause of these frequent over load trips. Besides overload trips, frequent break downs have also been realized. This has subsequently resulted in increase in the number of down times the milling circuits are experiencing.

3 OVERVIEW OF THE AUTOMATED CHARGING SYSTEM

The relationship between the multi-agent system designed in JADE for decision making and the control system developed in Siemens S7 for control of the hardware is outlined in Figure 1. The exchange of information and messages is facilitated by the use of an Object Linking and Embedding for Process Control (OPC), wherein the JADE program acts as the OPC server and the Siemens program as the OPC client. Vu Van Tan [9] state that OPC is a standardized interface for accessing process data and is based on the Microsoft Component Object Model (COM) and Distributed Component Object Model (DCOM). The OPC server is not a passive subprogram library, but an executable program which is started when the connection between client (PLC) and server (JADE) is established.

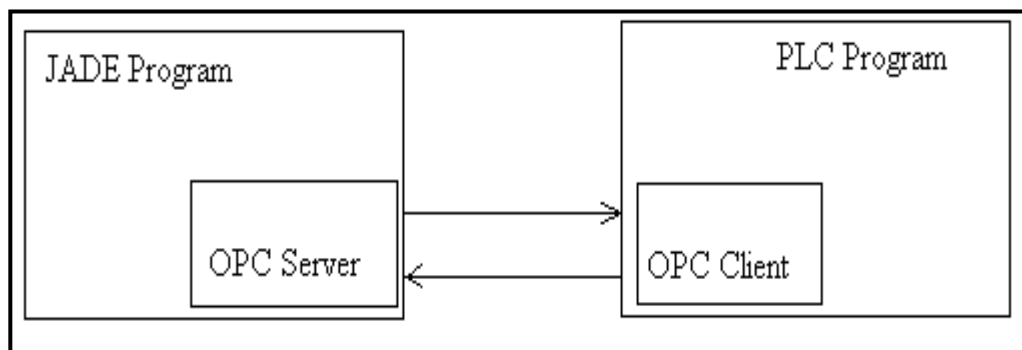

Figure 1: Link between JADE and PLC

The typical operating strategy of the automated charging system relies on the decisions made by the multi-agent system. The multi-agent system comprises of two agents namely the control and charging agents that interoperate to accomplish the requirements of the charging system. The idea behind the multi-agent system is to break down the complex problem of charging grinding media optimally, into smaller and simpler problem easily handled by the agents. The multi-agent system monitors the system parameters and then makes Boolean decisions corresponding to zero and one in control systems language. A zero is equivalent of a denial, while a one corresponding to an acceptance to charging. The system parameters of concern are mill load and power drawn by the ball mill. The milling operation is governed by equation 1.



The proposed agent architecture reduces the number of messages exchanged among agents and simplifies the overall complexity of a multi-agent implementation in automated charging system. In the automated charging system, each agent has unique objectives and responsibilities to be accomplished in order to meet the overall goal of making a decision on optimal conditions to charge grinding media.

4 METHODOLOGY

A company audit of MINE XXX was performed wherein charging quantities for the period February to March 2012 were compiled. Power-draws trends for the period from July 2011 to June 2012 were also monitored for Mine XXX after charging grinding media using the current conventional way of estimating the amounts to be charged. The challenges in the current systems of charging saw the variations in power draws as outlined in Figure 2. High levels of fluctuations in power draws are attributed to poor charging practices. The graph is not smooth owing to times when ball mills were run in extreme overloaded conditions and also in extreme under loaded conditions.

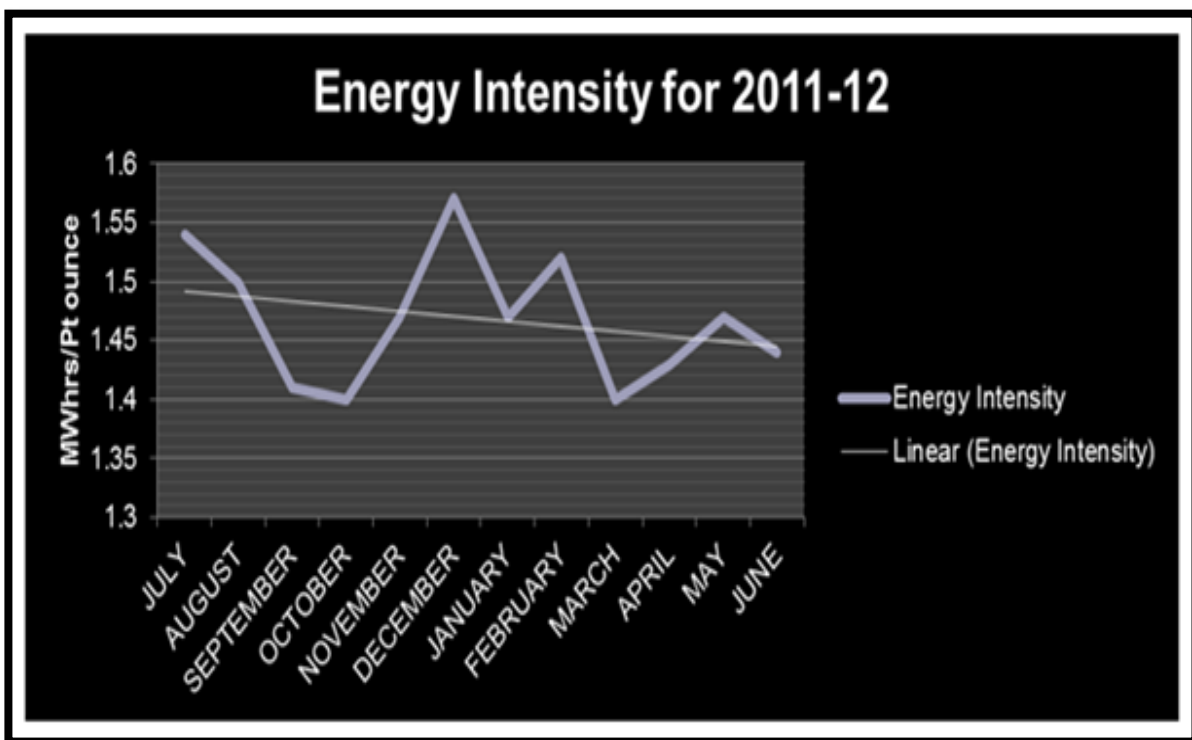

Figure 2: Power Draw Intensity Graph

Table 1 outlines the data that was collected for the primary ball mill in February and March 2012. It is expected that the mass of steel balls (grinding media) in kg/ton of ore milled should be approximately 0.24kg/ton, but one can clearly see the great deviation from this value. It therefore means that the wear rate of the grinding media in the current system is increased. Charging too much grinding media has been seen from literature to be a major contributor to escalated wear rates by Chen & Li [10], and Keshav et al [11].

An average value of 0.94kg/ton from the current wear rates was found after computing the highest and minimum wear rate during the period under study. The second column in Table 1 also shows a great deviation from the amounts that are supposed to be charged. At an ore feed rate of 300ton/hr and a media wear rate of 0.24kg/ton, after 8hours, 576kg of grinding media is supposed to be charged. The values given are therefore a witness of overcharging that is occurring in the system.

**Table 1: Charging values in kilograms ad kilograms per metric ton in primary milling**

Date	Mass of steel balls in Kg	Mass of steel balls in kg/ton of ore milled
6-Feb-12	2276	0.32
7-Feb-12	2222	0.31
9-Feb-12	5031	0.69
11-Feb-12	5160	0.72
12-Feb-12	5140	0.88
2-Mar-12	2250	0.31
3-Mar-12	2342	0.33
4-Mar-12	2350	0.33
5-Mar-12	11936	1.64

Table 2 is also showing the same challenge of overcharging wherein a wear rate of 0.18kg/ton is expected, but there is a significant deviation from this mark as seen in column 3. The amounts of grinding media charged per day are also significantly high owing to overcharging. The adverse effects of overcharging as discussed in section 2 of this paper are therefore inevitable.

Table 2: Charging figures in kilograms ad kilograms per metric ton in secondary milling.

Date	Mass of steel balls in Kg	Mass of steel balls in kg/ton of ore milled
6-Feb-12	1471	0.205
7-Feb-12	1124	0.156
9-Feb-12	323	0.052
11-Feb-12	1244	0.169
12-Feb-12	1391	0.192
1-Mar-12	2113	0.291
2-Mar-12	1899	0.262
3-Mar-12	1514	0.224
4-Mar-12	2474	0.348
5-Mar-12	0	0.000



5 AUTOMATED CHARGING SYSTEM DEVELOPMENT

In developing the multi-agent system and the control program, their interoperability was of great importance.

5.1 Multi-Agent Implementation and Design

JADE was selected for the implementation of the decision support system for the automated charging as it meets the IEEE and Foundation for Intelligent Physical Agents (FIPA) standards as supported by Dimeas & Hatziaargyrious [13]. Mark & Lazansky [13] and Woodridge [14] highlighted that the multi-agent system development for JADE involves agent specification, application analysis, application design, realization and implementation.

5.1.1 Agent Specifications

In this step, specifications of a control agent and charging agent in the Multi-Agent System are defined. Thus the responsibility of each agent is specified.

5.1.1.1 Control Agent

The control agent puts forth responsibilities that include the following:

- Monitoring the system's mill load and power draw.
- Making decisions on whether to charge or not based the status of the control parameters i.e mill load and power draw at the time of request to charge.
- Keeping the record of the media, its name and quantities to be charged.

5.1.1.2 Charging Agent

The charging agent is mainly responsible for making cyclic charging requests to the control agent. The charging agent is also responsible for:

- Accepting incoming registrations of milled tonnage from a weight meter on the feed conveyor.

5.1.2 Application Analysis

The second step involved formalization of agent roles and responsibilities that simplify understanding and modelling the problem at hand using a role modelling technique. This basically entails defining the roles played by each agent and also establishing the interaction with the external environment as summarised by Woodridge [14]. A collaborative diagram which defines the interaction among agents and their interaction with the environment needs shown in Figure 3 was developed.

The initialisation of the Multi - Agent System is performed by the control agent entering the media name and quantities to be charged in a harsh table. Both the control and charging agents have to register with the directory facilitator (DF) services so that they can adequately interoperate and get services from one another.

5.1.3 Application Design

The application design step involves a process of mapping agent responsibilities to problems that each agent attempts to solve. The charging agent is given a cyclic behaviour with a ticker time of one hour such that it requests to charge at that interval. Woodridge [14] illustrated that the control agent monitors the system parameters and then compliments the charging agent by making decisions on the right time to charge.

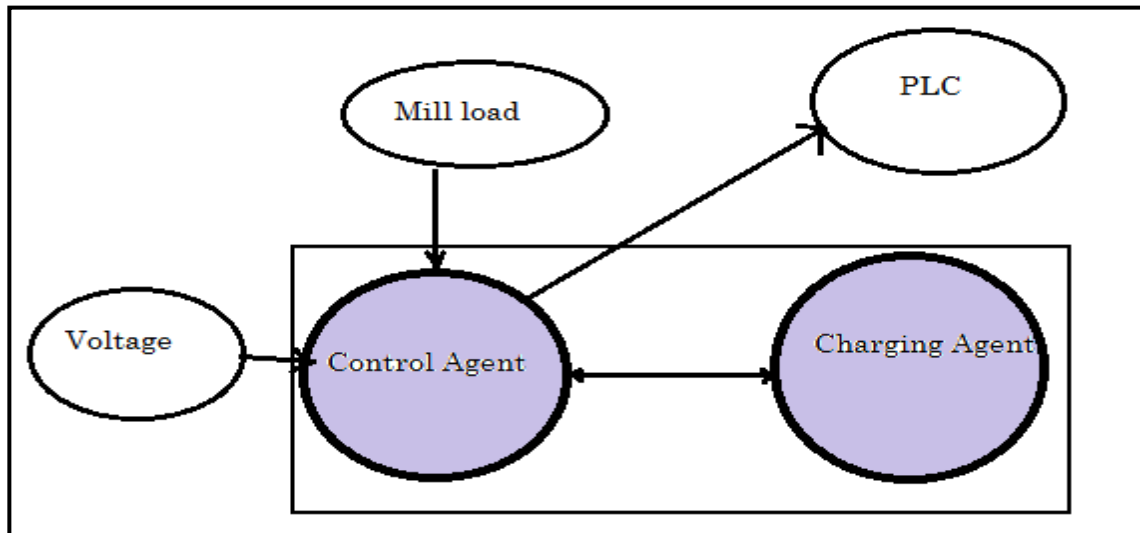

Figure 3: Collaborative Diagram

5.1.4 Application Realisation and Implementation

The application realization process consisted of protocol creation which involved the definition of the protocol used by the charging and control agent during communication. The messages adhere strictly to the Agent Communication Language (ACL) standard which allows several possibilities for the encoding of the actual content. Woodridge [14] highlighted how the multi-agent system developed makes use of the Call For Proposal (CFP). The request sent by the charging agent is such that it activates proposals by the control agent in terms of the optimum quantities to charge.

5.2 Control System Development

The control program in Siemens S7 1200 PLC developed will be controlling the hardware of the charging system. Basically the program is based on two inputs and two output devices as shown by Dunn [15]. Of the two input devices, the first input device receiving signals from the agent decisions works with digital signals, while the other work with analogue signals from the weighing modules. Table 3 summarises the equipment specifications for pneumatic gates which are actually the output devices.

Table 3: Component Equipment Specification

Equipment	State	Signal Type	Default State
Pneumatic Gate 1	Open-Close	Digital(1-0)	Close(0)
Pneumatic Gate 2	Open-Close	Digital(1-0)	Close(0)

The snippet of the ladder logix program controlling the hardware of the charging system was development and it is summarised in Figure 4. The first rung given shows how the first pneumatic gate is activated by the type of the agent message received via an OPC Server.

Assuming that the message was a yes, the first gate opens up to load the weighing bin. The preset value set on the weighing modules (load cells) is the mass corresponding to the ore milled at the time a charging request message is sent. The second rung shows how the first gate is reset and a subsequent opening up of the second gate to allow the media to be discharged into the ball mill.

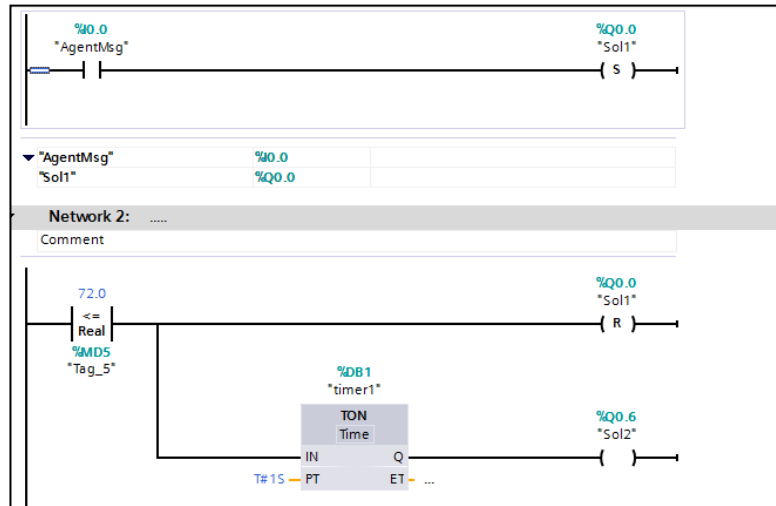

Figure 4: Ladder Logix Snippet

A flow diagram of how the ladder diagram works is illustrated in Figure 5.

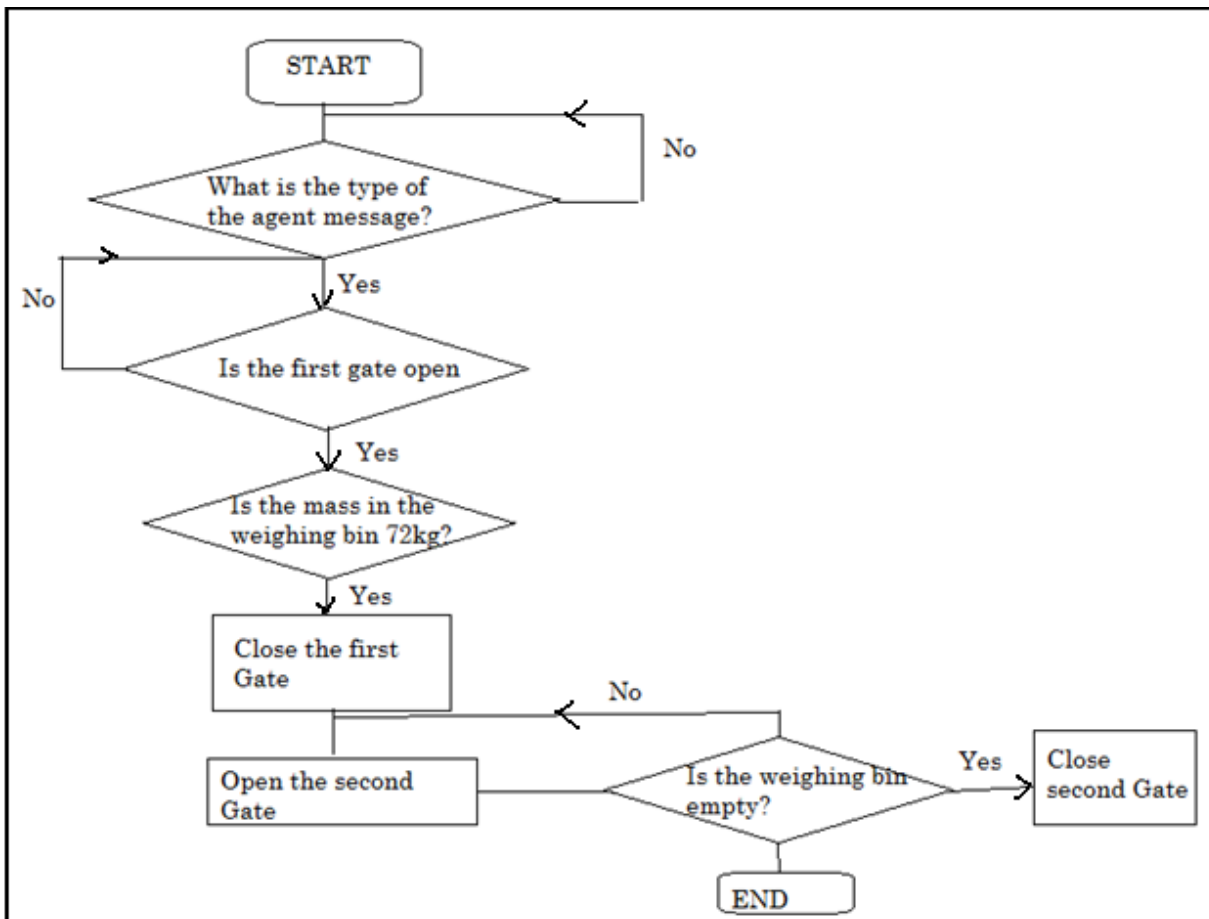

Figure 5: Ladder Flow Diagram

5.3 OPC COMMUNICATION LINK

An OPC Server must be used to establish the link between the JADE program and the PLC program. The OPC should solve the following challenges in the charging system designed:

- A constant value (e.g., a password) is to be written to the equipment automatically on startup. The Modbus RTU (serial) should be used as the communications protocol.
- Write this value on command from an operator.

- Allow monitoring of the communications status of the equipment.

The OPC Server should be linked to the JADE host computer and PLC central processing unit via TCP/IP serial ports. Figure 6 shows the block diagram of the link between the operator station which is basically the platform from which the JADE program is executed and the link to the PLC and ultimately to the equipment or hardware of the charging system as shown by Diaconescu & Spirleanu [16]. Similar work on communication optimization was done by Ndlovu et al [17] using multiple objective evolutionary algorithm.

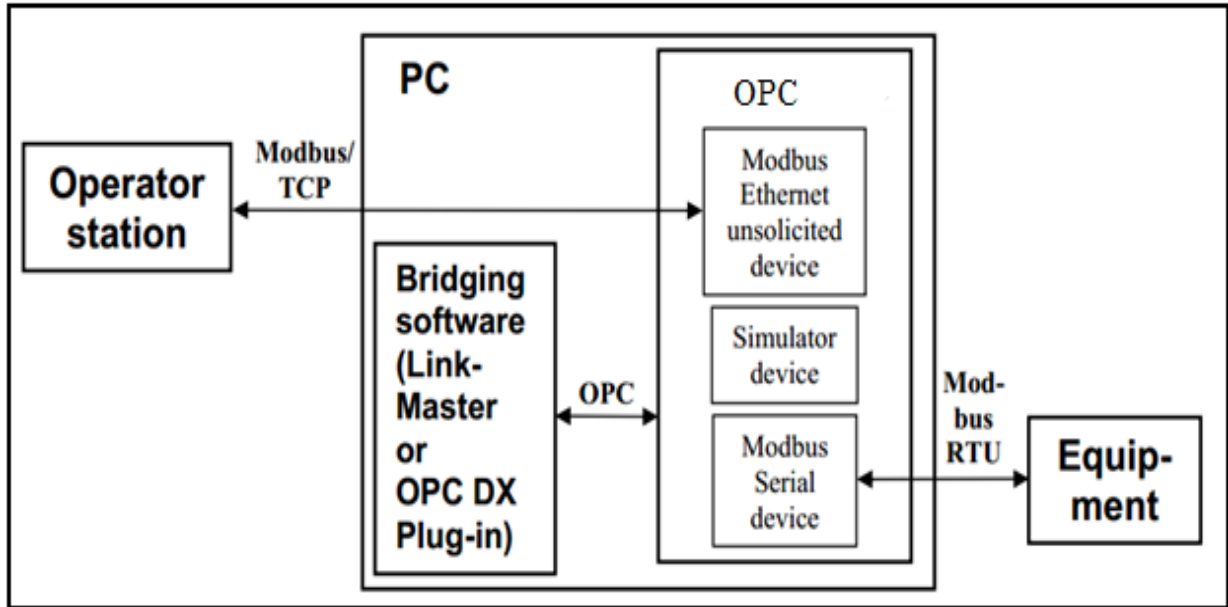

Figure 6: Block Diagram of the Software and Hardware

The application structure of the charging system incorporating the OPC Server, JADE program and PLC is based on a model by Diaconescu & Spirleanu [16] and will be outlined as shown in Figure 7 below.

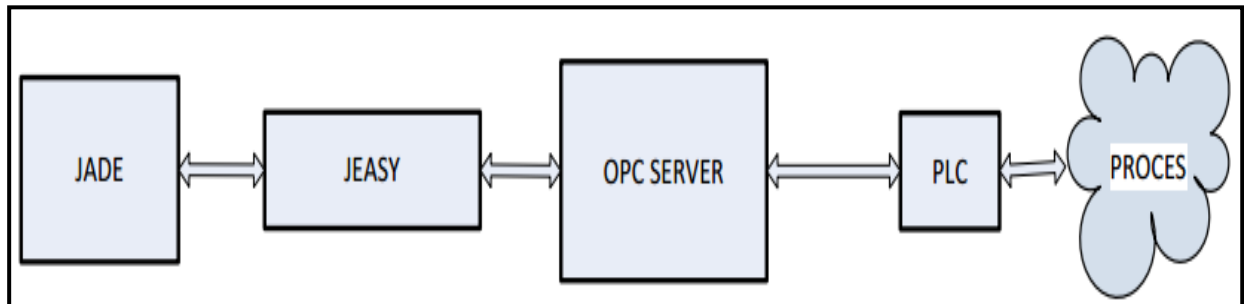

Figure 7: Application Structure [16]

The basic components of the application structure are defined as thus:

- Development environment (where JADE and PLC programs are running).
- Communication protocol (Modbus RTU).
- Jeasy OPC driver for interfacing with programs developed in Java.

6 RESULTS AND DISCUSSIONS

Discussed in this section are the results from the decision making process by the JADE program. The console applet was used for the discussion. The messaging between the agents is shown on a diagram similar to a UML sequence graph.



6.1 Jade Results

The outcome of the decision making process is outlined on a console platform in Figure 8. It also reveals some of the conversation messages being exchanged between agents as they perform their individual roles in making decisions.

```
Output - projectFarai (run)
INFO: -----
Agent container Main-Container@PrRupare-PC is ready.
-----
High Chromium inserted into catalogue. Quantity = 72
High Chromium inserted into catalogue. Quantity = 75
Hello! Charging Agent farai@PrRupare-PC:1099/JADE is ready.
Target media is High Chromium
Trying to charge High Chromium
Found the following control agent:
Controller 1@PrRupare-PC:1099/JADE
Controller 2@PrRupare-PC:1099/JADE
Millload :41
Powerdraw :1426
Received 41 and 1426
Attempt failed: requested media cannot be charged.
Trying to charge High Chromium
Found the following control agent:
Controller 1@PrRupare-PC:1099/JADE
Controller 2@PrRupare-PC:1099/JADE
Millload :36
Powerdraw :1388
Received 36 and 1388
High Chromium sent to agent farai@PrRupare-PC:1099/JADE
High Chromium media successfully charged by agent Controller 2@PrRupare-PC:1099/JADE
Quantity = 75
Charging Agent farai@PrRupare-PC:1099/JADE terminating.
```

First Block Request Denied

Second Block Request Accepted

Figure 8: Applet of the JADE Decision Process

Two blocks are outlined in Figure 8 showing two different scenarios in decision making by the agents. The scenarios shall be discussed as “Denial” and “Accept”;

Scenario 1 “Denial- First Block”

The charging agent has a cyclic behavior of sending requests to the control agent after every hour. The target media to charge is a start up argument given a name “High Chromium”. The system is prompted to search for the control agent. When the control agent is found, the system prints a message “.....Found the following control agents...”, and also list their nicknames e.g. “controller1”. At this stage the system is prompted to get the mill load and power draw values in order to make a decision in response to the request by the charging agent. The condition for accepting requests from the charging agent is an “AND” condition such that mill load has to be less than 42% and power draw has to be less than 1400kW, else deny.

The last statement in the first block in Figure 8 says “...Attempt failed: requested media cannot be charged...” because the system parameters received are greater than the set optimum, thus 41% and 1426kW. The message is then converted to a Boolean zero such that the PLC is not activated to open first pneumatic gate on the storage bin side.

Scenario 2 “Accept- Second Block”

The second scenario is a reverse of scenario 1. The last three statements in the second block in Figure 8 show a case when an acceptance is given by the control agent because the system parameter received are lower than the set points, thus 36% and 1388kW. The acceptance message is converted to a Boolean one that is sent to a PLC to close the first gate on the storage bin side and open the gate on the weighing bin side.



6.2 Intercepting Messages between Agents

A Sniffer agent was used to intercept messages while they were in flight and displays them graphically using a notation similar to Unified Modeling Language sequence diagrams. Intercepting messages is useful for debugging the agent societies by observing how they exchange ACL messages. The outcome of this exercise is displayed and summarised in Figure 9.

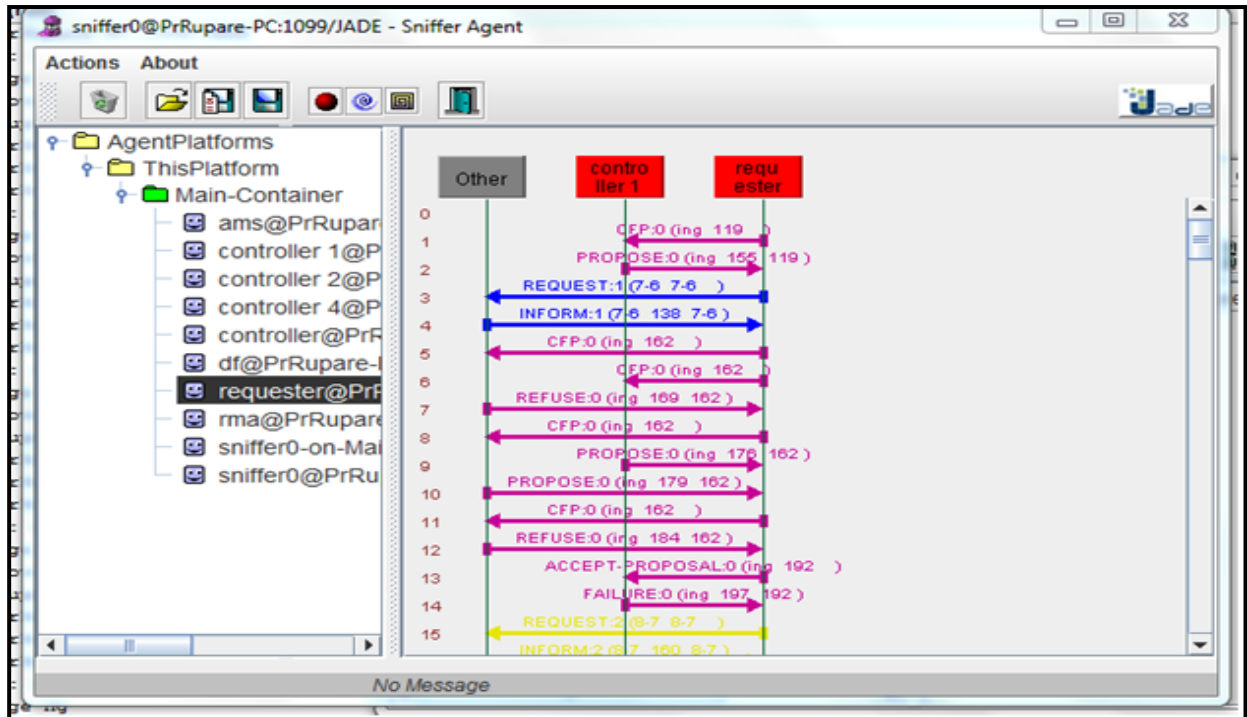

Figure 9: Applet of the Messages Intercepted by the Sniffer Agent

7 FUTURE WORK

The configuration of the link between the JADE program and the PLC has to be performed to ascertain the integrity of the link in the charging system using an OPC Server as briefly discussed in section 5 of this paper. The integration of multi-agent systems into bigger mines and other organisations running ball mills also has to be explored further. Further research into the interoperability of multi-agents and control systems has to be done in order to improve the quality of information available so far in the knowledge body and also its application in other fields.

8 CONCLUSION

The automated charging system was designed to help optimize communiton circuits and reduce the cost associated with running the process. The paper set to highlight background of the Case Study Company and possible improvements in steel ball charging systems. The system was developed that would increase the line production due to an efficient plant which will use agent based systems to control the process. The world has become increasingly aware of the need to optimize resources that are used in every stage of production; hence the Hybrid system comes in handy in this area. The ability by organisations to conserve energy and optimize the use of resources will result in sustainable development. The ability to reduce the cost associated with production is major tools that will see organisations escape the setting sun and current economic hardship in the world.



9 REFERENCES

- [1] Kotake, N., Kuboke, M., and Kayanda, Y. 2010. Influence of Dry and Wet Grinding. *Journal of Advanced Powder Technology*, 24(5), pp 1-4.
- [2] Zhao, L., and Yuan, D. 2012. Multi-classification of ball mill load status. *Journal of Theoretical and Applied Information Technology*, 43(2), pp 694-699.
- [3] Erdem, A. S., and Ergun, L. S. 2009. The Effect of Ball Size on Breakage Rate Parameter in a Pilot, *Journal of Minerals Engineering*, 22(3), pp 660-664.
- [4] Yang, J., and Li, X. 2010. Disturbance Rejection of Ball Mill Grinding Circuits . *Powder Technology*, 198(2), pp 219-228.
- [5] Bernard, d. H., Benoît, C., and Olivier, H. 2008. Real Time Mill Management Tool, *Optimising Your Milling Process and Reducing your cost*, 3(1), pp 1-16.
- [6] Fuerstenau, D. W., and Abouzeid, A. Z. 2002. The Energy Efficiency of Ball Milling in Comminution. *International. Journal of Mineral. Processing*, 67(4), pp 161-185.
- [7] Powell, M., and Smit, L. 2006. The Selection and Design of Mill-Liners. *Advances in Comminution*, 43(4), pp 331-376.
- [8] Dimeas, A., and Hatziargyriou, N.D. 2006. Operation of a multiagent system for microgrid control, *IEEE transaction on Power Systems*, 20(3), pp 1447-1455.
- [9] Vu Van Tan, M.J.Y. 2011. Development of an OPC Client-Serverr Framework for Monitoring and Control Sytems. *Journal of Information Processing Systems*, 7(2), pp 321-322.
- [10] Chen, X. S., and Li, Q. 2008. Supervisory Expert Control for Ball Mill Grinding Circuits. *Expert Systems with Applications*, 34(2), pp1877-1885.
- [11] Keshav, P., de Hass, B., Clermont, B., Mainza, A., and Moys, M. 2011. Optimisation of the Secondary Ball Mill using an on Line and Pulp Load Sensor. *Mineral Engineering*, 24(1), pp325-334.
- [12] Dimeas, A., and Hatziargyriou, N. D. 2005. Operation of a multiagent system for Microgrid control. *IEEE transaction on Power Systems*, 20(3), pp1447-1455.
- [13] Marik,V., Lazansky, J. 2007. Industrial aplications of agent techologies, *Control Engineering Practice*, 15(1), pp1364-1380.
- [14] Wooldridge, M. 2002. *An introduction to Multiagent Systems*, John Wiley & Sons
- [15] Dunn, W. C. 2005. *Fundamentals of Industrial Instumentation and process Control*.1st Edition, McGraw-Hill Companies, New York.
- [16] Diaconescu, E. and Spirleanu, C. 2009. Communication solution for industrial control applications with multi-agents using OPC servers. *Proceedings of the International Conference on Applied and Theoretical Electricity (ICATE)*, Craiova, Romania.
- [17] Ndlovu J, Mhlanga S, Mbohwa C, Mutingi M, 2011. Design of Comminution Circuits for Improved Productivity Using a Multi-Objective Evolutionary Algorithm (MOEA), The IEEE, *International Conference on Industrial engineering and Engineering Management (IEEM2011)*, 6-9th December 2011, Furama RiverFront Hotel, Singapore.