

Dynamics of Public Relations and Journalism

A practical guide for media studies

— **Fourth Edition** —

Editor

Annette Clear
MA Communication

Contributors

Marla Koonin
MA Journalism (cum laude); CPRP

Maritha Pritchard
MTech Journalism



Dynamics of Public Relations and Journalism 4th edition

First edition 1997

Second edition 2001

Third edition 2011

Fourth edition 2015

Juta and Company (Pty) Ltd

PO Box 14373, Lansdowne, 7779, Cape Town, South Africa

© 2015 Juta and Company (Pty) Ltd

ISBN 978 1 48510 287 8

All rights reserved. No part of this publication may be reproduced or transmitted in any form or by any means, electronic or mechanical, including photocopying, recording, or any information storage or retrieval system, without prior permission in writing from the publisher. Subject to any applicable licensing terms and conditions in the case of electronically supplied publications, a person may engage in fair dealing with a copy of this publication for his or her personal or private use, or his or her research or private study. See Section 12(1)(a) of the Copyright Act 98 of 1978.

Project Managers: Karen Froneman & Seshni Kazadi

Editor: Angela Voges

Proofreader: Language Mechanics

Cover designer: Jacques Nel

Typesetter: L&T Design Worx

Indexer: Sanet le Roux

Picture credits:

Figure 10.2, p 123: Courtesy of OFM

Figure 13.9, pp 171 - 185: Courtesy of Mark and Graeme Rushmere

Figure 15.2, p 209: Michelle 2012

Figure 15.3, p 213: Courtesy of Z PR Communication Consultants

Fig17.2A, p 247: Courtesy of Marilette Henning

Fig 17.2B, p 248: Courtesy of Z PR Communication Consultants

Typeset in Myriad Pro 10pt on 14pt

Printed in South Africa by 

The author and the publisher believe on the strength of due diligence exercised that this work does not contain any material that is the subject of copyright held by another person. In the alternative, they believe that any protected pre-existing material that may be comprised in it has been used with appropriate authority or has been used in circumstances that make such use permissible under the law.

Contents

Preface	viii
Acknowledgements	x
PART 1 PUBLIC RELATIONS AND JOURNALISM – AN INTRODUCTION	1
Chapter 1: What are public relations and journalism?	5
Introduction	5
A: Public relations	7
Definition of public relations	7
The purpose of public relations	8
Image building	8
Communication	9
The role of the public relations practitioner	12
Technical, management and strategic roles	12
B: Journalism	15
Definition of journalism	15
The purpose of journalism	16
The role of the journalist	16
C: Duties of the two professions – public relations and journalism	20
Summary	21
Test yourself	21
Chapter 2: Combining public relations and journalism in Media Studies	23
Introduction	23
Interaction between public relations and journalism	24
Journalistic skills needed by the public relations practitioner	26
Summary	29
Test yourself	29
Chapter 3: News and public relations	31
Introduction	31
What is news?	32
Characteristics of news	33
News values	34
Types of news	36
Categories of news	37
Public relations and news	38
Target audience (external and internal) for the public relations practitioner	40
News sources	42
Creation of news	48
Summary	48
Test yourself	49
Chapter 4: Ethics in public relations and journalism	51
Introduction	51
Facing moral ethics	55
Legal ethics and the public relations practitioner	58

Summary	61
Test yourself	62
PART 2 SENDING YOUR MESSAGE THROUGH THE MEDIA	63
Chapter 5: Introduction to the print media – newspapers and magazines	65
Introduction	65
The nature of the print media	66
Advantages and disadvantages of the print media	67
Some differences between newspapers and magazines	67
The print media in South Africa	68
Readership and circulation	69
Putting the media to work	70
Summary	70
Test yourself	70
Chapter 6: Print media – newspapers	71
Introduction	71
Types of newspapers	72
The appearance and style of newspapers	75
Functions, target market and content	76
Structure of editorial department and staff duties	83
Contacting the newspaper	85
How a newspaper operates	85
Summary	87
Test yourself	87
Chapter 7: Print media – magazines	89
Introduction	89
What makes a publication a magazine?	90
Types of magazines	90
Functions, readers and content	92
Editorial structure and functions of each member	92
Functions of members of staff	93
How magazines operate	94
The public relations practitioner and magazines	95
Summary	96
Test yourself	96
Chapter 8: Introduction to the electronic media – television and radio	97
Introduction	97
The South African Broadcasting Corporation (SABC)	98
Other South African television services	100
The radio network	101
Regulating the industry	104
Summary	105
Test yourself	105

Chapter 9: Electronic media – television	107
Introduction	107
Structure of television news	109
General tips for the public relations practitioner when dealing with television journalists	113
Categories of television programming	115
Summary	117
Test yourself	118
Chapter 10: Electronic media – radio	119
Introduction	119
Structure of the radio service	121
Radio newsroom	122
Radio news regional editors	123
Whom to contact	124
How the radio journalist works	124
Categories of radio programming	126
Time schedules	128
How public relations practitioners can assist radio journalists	128
Summary	131
Test yourself	131
Chapter 11: Digital or new media	133
Introduction	133
What is digital or new media?	134
McLuhan's global village	135
Public relations and digital or new media	135
What exactly is the Internet?	138
What is on the Internet?	139
The World Wide Web (WWW)	140
E-mail	142
Newsgroups	143
Chat and instant messaging	143
Online media	144
The impact of digital or new media technology on the public relations profession	145
Digital media technology and public relations	146
Summary	147
Test yourself	148
Chapter 12: Corporate social media	149
Introduction	149
Social media as a public relations function	150
Characteristics of corporate social media as a public relations function	150
Web 2.0 as the technological driver of social media	155
User-generated content and social media	156
The attributes of social media engagement	158
Popular social media networks	160
Summary	164
Test yourself	165

Chapter 13: How to use the various media	167
Introduction	167
Practical exercises	167
Summary	186
PART 3 ESSENTIAL JOURNALISTIC SKILLS FOR THE PUBLIC RELATIONS PRACTITIONER	187
Chapter 14: Interviewing skills	189
Introduction	189
How to conduct interviews (as interviewer)	190
How to handle an interview (as interviewee)	194
Tips for a television interview	196
General tips for handling the media	197
Interview scenarios to consider	198
Summary	200
Test yourself	200
Chapter 15: Photographic skills	201
Introduction	201
Features of a digital camera	202
Practical photography	205
Photographic opportunities and types of photographs suitable for different occasions	209
Factors contributing to good photographs	212
General tips	216
Summary	217
Test yourself	217
Chapter 16: Writing skills	219
Introduction	219
Writing skills needed by public relations practitioners	220
Media releases	220
General writing tips	229
Online writing tips	230
Online press rooms	233
Features	233
General articles	237
Light stories	237
Captions	237
Photographic pages	239
Headlines	239
Summary	241
Test yourself	241
Chapter 17: Design and page layout	243
Introduction	243
What does editing involve?	244
Approaching page layout	250
Desktop publishing	265
Summary	269

Contents

Test yourself	270
Bibliography	271
Index	278

Preface

Unravelling the complex worlds of public relations and journalism in a single publication is not easy. However, when the dynamics of these two unique occupations are established, their interaction becomes apparent.

This book follows a unique approach, illustrating how public relations and journalism interact in the field of Media Studies. This work shifts the strong emphasis currently placed on journalistic skills to public relations and media handling. It also focuses on the journalistic skills that the public relations practitioner needs to complete technical tasks effectively.

This edition is an attempt to keep up with the strong digital media influence in organisations. In looking at how public relations is evolving, we also need to look at how journalism is evolving because the two have a direct influence on each other. Digital media may be changing the face of both the public relations and journalism professions, but the basic principles of good ~~and~~ journalism remain unchanged. Technology changes so quickly – you as a public relations practitioner will always need to keep up with the trends and changes in the digital media environment. **public relations**

Even with the strong influence of social media, traditional media will never go away. The main focus of this book is on traditional media and the basics of public relations and journalism, which provide the foundation of a better understanding of the power of social media. Traditional and social media both have roles in public relations. It is important to understand these roles and learn how to use these media types in public relations efforts. Mass media such as newspapers, magazines, radio stations and TV channels, remain the principal channel of communication for reaching the largest number of people or target audiences. Increasingly, online media such as websites, blogs, Facebook, Twitter and many others are being added to the media array that practitioners utilise for disseminating key messages and creating widespread public awareness.

The material, including various practical examples and exercises, offers a South African perspective. This gives the user meaningful insights into the relationship between public relations and journalism in this country. Public relations practitioners are able to familiarise themselves with the complexities of journalism, and journalists gain an understanding of the public relations practitioners' media-handling role.

The book is divided into three parts. Part 1 examines the basics of public relations and journalism and their interaction, with an introduction to digital media where relevant. It also establishes what news is and determines where it is to be found. Part 2, which investigates the South African mass media, focuses on print and electronic media. The structures and functions of the editorial newsrooms of the different media are discussed. The reader is shown how the public relations practitioner and the journalist combine their expertise to publish news. Part 2 further introduces digital or new media and

includes a new chapter on corporate social media. Here, we look at social media as a public relations function and describe the attributes of social media engagement while elaborating on popular social networks that may be used by the corporate social media team. We have also added a topical case study showcasing the role and interaction of traditional and digital media in an organisation. Part 3 is a practical, step-by-step guide to the journalistic skills that public relations practitioners need, and focuses on interviewing, photography, writing, editing and design and page layout.

The authors of this practical manual have relied on their own extensive experience in public relations and journalism,  ~~making little use of existing publications~~. They address the many problems that public relations students under their supervision experience in the subject of Media Studies.

With the help of this text, public relations students and practitioners, journalists and managers in every sector of the South African economy should gain a better understanding of the unique, mutually beneficial relationship enjoyed by those in public relations and journalism.

Written in an interactive style, the book encourages the reader to take part in a quest to understand the attributes shared by the two disciplines and to appreciate their mutual importance.

Annette Clear
(editor)
2014

Acknowledgements

Although we realised that students needed a detailed book giving a clear exposition of the interaction between public relations and journalism, it was only after a great deal of encouragement that we decided to put our thoughts and experience into a single, comprehensive publication, closing the gap in the available literature.

Sadly, my co-author, Linda Weideman, passed away in 2008, but her legacy lives on in this fourth edition, as we continue to build on the cornerstones she laid down with so much enthusiasm and an endless well of knowledge.

This edition is a special dedication to Linda as many of her valuable contributions are slowly being replaced – the old with the new. The basics will always stay the same, but gradually we have to give way to the power of technology in the growing fields of public relations and journalism.

This book could not have been written without the assistance and support we received from several people.

We thank the staff of the South African Broadcasting Corporation for opening the complex world of electronic media to the public relations practitioner. We are also grateful to spokespersons from various print media for their invaluable input.

On the academic side, we are indebted to Professor Arrie de Beer of the University of Stellenbosch who believed the book would contribute to a greater understanding and appreciation of both professions. His time and effort during the preparatory stages of the first edition are greatly appreciated.

To our colleague and friend, Ingrid van Jaarsveld, who unselfishly shared her public relations and journalistic skills with us and gave her impressions of and ideas about each chapter – thank you!

Linda's passing opened an opportunity for fellow educators to step in and contribute their valuable expertise and experience to the uniqueness of this book. As editor, I am therefore very grateful to co-contributors Lydie Terblanche, Veena Parboo Rawjee and her team, Nisha Ramlutchman and Zwakele Baldwin Ngubane, for their contribution to the third edition.

The fourth edition was a challenge as digital media has since 'invaded' public relations and journalism. We could not ignore the existence and growth of digital media in these fields, yet needed, at the same time, still to emphasise the importance of traditional media. Combining public relations and journalism in a single publication is a challenge on its own; having to include both traditional and digital media in these fields and to try to make sense of it all took some hard thinking and much rewriting of some chapters to integrate the public relations strategy that blends online and offline communication touchpoints. I couldn't have done this without the enthusiasm, support, knowledge, expertise and most valued contributions from my two new co-contributors, Marla Koonin

and Maritha Pritchard. Thank you for your belief in this book and for taking this journey with me to make this new edition a must-have for students and lecturers. I believe that, in the end, we conquered, and now have a strong foundation on which to build further developments that we may face in public relations and journalism.

Last but not least, we thank Corina Pelsler from Juta for her invaluable assistance and encouragement throughout and also all of Juta's editing and technical staff for their invaluable assistance in publishing the first, second, third, and now fourth edition.

Annette Clear

(editor)

2014



PUBLIC RELATIONS AND JOURNALISM – AN INTRODUCTION

Public relations (PR) and journalism are two distinct disciplines, each having its own functions and objectives. However, the relationship between public relations and journalism is, and always has been, a complex and necessary symbiotic liaison of mutual dependence. Public relations and journalism can be seen as two sides of the same coin. One side has news and interesting events it wants to get out into the public domain; the other side needs news and interesting events to cover (Curtis 2011).

The relationship between these two communication professions is under constant pressure. The increasing professionalism of the management of news on the side of public relations and the explosive growth in media supply that has resulted in increased competition between journalists and an intense contest for the news are two factors creating pressure.

The most important function that these professions share is conveying *newsworthy* information via various channels of communication. A channel is the way in which a message gets to its intended audience, such as via print media, social media platforms/applications/tools, radio broadcasts, etc. Public relations practitioners (PRPs) execute the publicity function by providing information to the media that the public relations practitioners would like to see published or broadcast about their organisation, product or event. Journalists often use the public relations practitioner's information for material. However, this will only happen if that material is newsworthy.

Therefore, it is critical that both public relations practitioners and journalists understand what makes something newsworthy and what is important to their specific *target audience*. The main difference between a journalist and a public relations

Newsworthy: when it is believed that the information on hand is something in which the public would be interested

Target audience: specific, identified groups that are important to the organisation or the media medium

Media medium: the media system that carries the message, for example, newspaper, radio and social media platforms such as Twitter and Facebook

practitioner in this regard is the manner in which they convey this information and their reasons for doing so. This can be easily understood when comparing the different purposes and roles of each profession.

In order for a public relations practitioner to ensure that a journalist will use his or her information in any *media medium*, it is critical for the public relations practitioner to know which style of writing and type of information the journalist is looking for. The public relations practitioner needs to understand journalism to do this. Public relations practitioners dealing with the media must understand the media's opportunities and limitations to engage in the journalistic process of story creation. Public relations needs to facilitate media coverage and is therefore a necessary component of the media work process.

One of the public relations practitioner's main functions is media relations. Public relations practitioners deal with the various media to ensure that the message that they want their target audience to receive is conveyed via the media. This media messaging is important so that the public relations practitioner can ensure the promotion of an image or an idea to defend a cause or just carry influence for his or her organisation or purpose. Many practitioners fail to achieve their objective because they do not have sufficient experience and knowledge of, firstly, what the media consider to be newsworthy; secondly, preparing material in a way that is acceptable to the media; and thirdly, dealing with journalists.

Getting media publicity is a critical part of a public relations practitioner's job. Public relations practitioners and consultants are often called to task by management for not achieving sufficient positive media publicity. Usually, this failure can be pinned on lacking in awareness of the media's primary need: to publish or broadcast information that can be construed as news.

Identifying newsworthy information and presenting it appropriately to the media is essential. If publicity is to be gained, each media medium has to be used in its preferred manner and style of publication. In other words, you would not construct a feature article for a magazine in the same way as you would a newspaper article. Also remember that some publicity mediums used directly by the public relations practitioner – such as tweets, Facebook entries or blogs –

still need to be written in a way that catches the attention of audiences and is newsworthy. You will only gain publicity if you know how to write for each media medium, whether traditional or social media. The skills required for doing this can also be applied when advising management about the complexity of the various media mediums. If management is sympathetic, it will put less pressure on public relations practitioners to deliver.

To a large extent, journalists depend on public relations practitioners for material to fill their publications and news slots. The gathering of newsworthy information is essential to a mass media medium's survival. Journalists report and cover events every day for news outlets and mass media. The more successful the media are in gathering and conveying newsworthy information, the higher their circulation and viewer figures will be. As it is the task of public relations practitioners to handle the media and to act as a link between the journalist and organisational management, they play a major role in giving journalists access to newsworthy information. For example, if something newsworthy is happening within your organisation you will be the source of information for the journalists.

There is often a misconception among journalists that public relations practitioners only cover up and do not supply the real, hard facts. Journalists are sometimes sceptical about information received by public relations practitioners or their departments about controversial issues. Public relations practitioners should always remember that the media want to cover the full story and will, in most cases, consult other sources as well. They should take care to provide factual information and be credible at all times.

Both professions need to understand that the relationship between public relations practitioners and journalists is beneficial on condition that one of the professions does not step on the other's turf.

We are all aware today of the strong social media influence on organisations and in looking at how public relations evolves, we also need to look at how journalism evolves as the two have a direct influence on each other. There is no doubt that social media are changing the face of both the public relations and journalism professions and are morphing into something new – but while digital technology has changed many of the ways in

which these two professions share their messages and interact with each other and their target audience, the basic principles of good public relations and journalism remain unchanged (Elgie 2012).

Despite the strong influence of social media, traditional media will never go away. The main focus of this book is on traditional media and the basics of public relations and journalism, the foundation on which you can build your knowledge to gain a better understanding of the power of social media. Traditional and social media both have roles in public relations. It is important to understand these roles and learn how to use them in your public relations efforts. Mass media channels – newspapers, magazines, radio stations and TV channels – remain the principal channels of communication for reaching the largest number of people or target audiences. Increasingly, online media such as websites, blogs, Facebook, Twitter and many others are being added to the media array that public relations practitioners utilise for disseminating key messaging and creating widespread public awareness.

The rules of public relations have changed: you need to build a compelling story and share it on both traditional and social media platforms in order to influence your audience, change opinions and make an impact on the community.

Part 1 serves as an introduction to the fields of public relations and journalism. We look briefly at the purpose, role and responsibility of each profession. We then establish how public relations and journalism are interrelated and can be combined into an area of study called Media Studies. In the third chapter, we deal with the important subject of news and discuss how the public relations practitioner can identify and gather newsworthy information that will be acceptable to the media. The fourth chapter deals with ethics in public relations and journalism.

What are public relations and journalism?



Objectives

After you have studied this chapter, you should be able to:

- define public relations and journalism
- discuss the purpose and role of public relations in an organisation
- discuss the purpose and role of the journalist employed by the mass media.

Introduction

This chapter gives an introductory overview of public relations and journalism. It will enable you to differentiate between public relations and journalism and to identify their purpose and roles. It aims to illustrate how the subject of Media Studies embraces public relations and journalism and to help develop cross-industry editorial and production skills. For public relations purposes, Media Studies is two-sided. On the one hand, public relations practitioners need a working knowledge of the *mass media* at their disposal and the skills for dealing with the journalists who work for these media outlets. On the other hand, they need specific journalistic skills such as interviewing, article writing, photography and page layout to produce, for example, internal and external house publications.

Mass media: media types encompassing traditional media (which use technical channels to convey messages to a large, diverse audience or the general public, eg radio, television, newspapers and magazines) and what some term *new media* (which are digitally orientated media).

Figure 1.1 illustrates the place of public relations and journalism in Media Studies.

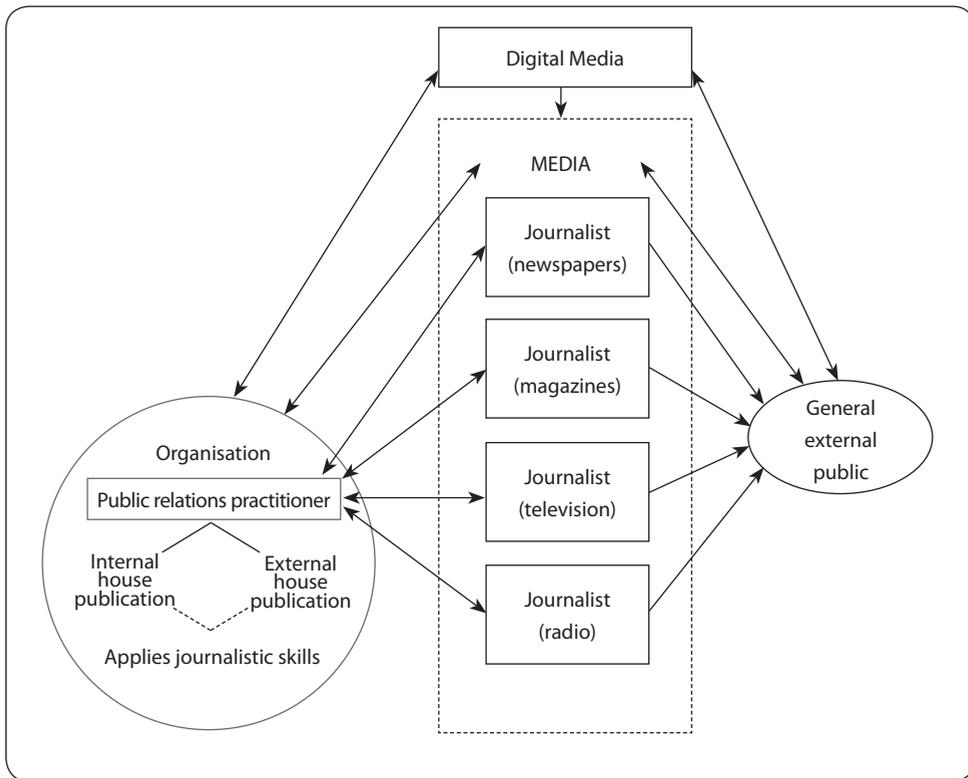

Figure 1.1 The link between public relations, journalists and digital or new media

A

Public relations

Definition of public relations



Exercise

Describe, in your own words, the term public relations. Compare your description to the definition given below.

Public relations is the management, through communication, of perceptions and strategic relationships between an organisation and its internal and external stakeholders
– Public Relations Institute of Southern Africa (PRISA)

Although several other definitions are often used, this definition describes the concept of public relations in a holistic manner. The definition also makes it clear that effective communication has to take place in public relations and that public relations is a strategic function. Today, many communications managers hold director positions in large companies all over the world, showing the importance of the internal and external communication function to an organisation. Communication is the backbone of public relations. Public relations practitioners must familiarise themselves with the many communication forms and techniques available for establishing effective communication with their organisation's target audience.

Today, the public relations function is regarded as one of the most important components of any organisation. Organisations are increasingly realising its great value. However, many managers still underestimate the role and functions of public relations, which is why public relations practitioners often have to fight for their profession to take its rightful place in their organisations. If they encounter such problems, they should educate management about the value and benefits of sound public relations practice.

Once management understands the place and role of public relations in the organisation, public relations practitioners will be able to function with management support. Because

they often have to discuss and clarify aspects of policy and sensitive issues, they should have direct access to the head of the organisation.

However, not all managers understand public relations, and management's perceptions that public relations practitioners are sometimes inadequately trained for their demanding profession and often lack necessary skills are, at times, well founded. Public relations practitioners should not allow this perception to persist, and should ensure that they are qualified and competent in all aspects of public relations.

The purpose of public relations

Public relations concerns itself with developing an organisation's image by creating effective, two-way communication channels between management and employees and between management and the organisation's external target audiences.



Exercise

What do the terms image building and two-way communication channels mean? In your own words, write down what you think these two concepts describe. Compare your answer to the discussion below.

Image building

Image building means promoting an organisation's image. The public relations practitioner must ensure that an organisation's policies, products and services are acceptable to the public and that the public is aware of them. Public relations creates an understanding of and goodwill towards the organisation, which leads to greater confidence and belief in the organisation.

What the public knows or thinks about the organisation determines whether the organisation has a positive or a negative image. The public relations practitioner, therefore, controls the information the organisation puts out to the various target audiences. This is known as the corporate identity of an organisation (see below for an explanation). It helps to build the organisation's image because what you say will influence people's perception of your organisation and, thus, your image.

The public relations practitioner tries to make sure that what is said about the organisation internally and externally is positive and helps to build the company's image and reputation. Hand in hand with the organisation's image is its corporate identity. This is anything that the organisation says or puts out about itself, such as the organisation's logo, corporate colours, mission, vision, etc.

It is important to know that the public relations practitioner can control the identity of the organisation but not the image. The organisation's image is perception-based. As a public relations practitioner, you need to keep perceptions of the organisation positive through the identity you put out there, while ensuring that the organisation and its stakeholders, such as employees, live up to the organisation's vision, mission and other elements of the organisation's identity.

Communication

To be highly effective and successful, it is crucial that an organisation first learns to communicate effectively. Two-way communication leads to greater understanding – and understanding enables management to create strategies to drive behaviour and achieve necessary targets. This is the vital business cycle that is needed to generate success (French 2014). Communication is one way to shape and define an organisation's image in the eyes of the community, clients and potential investors.

Two-way communication implies sending a message, receiving feedback from the intended audience and establishing a mutual understanding of the message. The sender can use various channels to send a message to an audience. The channel of choice depends on who the audience is. Public relations uses different channels for internal and external communication.

Internal communication

Internal communication is, for example, communication between management and employees. The public relations practitioner acts as a link between management and employees by channelling information to the employees. An example of this type of channel is an organisational newsletter. If the newsletter has a section in which employees can raise concerns or write to the editor, this would be considered a platform for

employees to raise issues with management. An even better idea would be for each edition to include a response from management to each of the issues raised. The public relations practitioner should always communicate with employees through appropriate internal communication channels that are personalised and build positive sentiment. These channels need to be a genuine means of communication between management and employees. This cannot happen through mass media directed at a large and diverse audience. It would be bad public relations practice for employees to hear about major organisational messages in the mass media.

We distinguish between formal and informal internal communication channels available to the public relations practitioner.

There are four main categories of formal communication channels: electronic channels (such as SMS messaging, social media, blogs, podcasts, e-mails, company intranets and electronic newsletters); print channels (such as hard-copy newsletters, brochures, posters and magazines); face-to-face channels (such as meetings); and channels in the workplace (such as noticeboards and electronic screens that display messages).

Informal channels reflect the non-linear dynamics of a social network and can be as – if not more – influential than official or formal channels. They are often more likely to stimulate and create discussion and dialogue. The channels may manifest themselves via the grapevine, social networking, etc.

More organisations are realising the importance of social media for internal communication. For this to be successful, however, public relations practitioners will have to take it up as an opportunity to persuade management to engage with employees in the 'new age' way (Biwalkar 2013).

If public relations practitioners are to establish internal communication channels through newsletters or various other mediums directed at employees, they will need, among others, good writing skills and knowledge of photography, graphics, etc. They will have to oversee the layout and design of these publications with the help of desktop publishing programs and hardware. These functions include some of the journalistic skills that the public relations practitioner should acquire.

External communication

External communication is any communicative effort specifically for people and organisations outside of the business. Factors including the type of organisation and the organisation's objectives will determine with whom the organisation communicates. External communication focuses on spreading news and information about the organisation to the target audience and company stakeholders. The public relations practitioner conveys messages to specific people outside the organisation through, for example, an external *house publication*, corporate advertisements, media releases, Facebook pages and an organisational website, to name but a few. These inform the public about the company and its environmental efforts and other image-related activities to strengthen the company's public relations efforts. The people targeted could include the immediate community, shareholders, opinion leaders and other organisations. The journalistic skills mentioned earlier are also used in producing external communication.

The public relations practitioner might want to bring an issue to the attention of the general public, which forms part of the external target audience. To do this effectively, the public relations practitioner should use a combination of the traditional media (newspapers, magazines, radio and television) as well as *new media* platforms such as Facebook, Twitter, the organisational website, etc, as communication channels. The various media mediums are probably the public relations practitioner's most important channels of external communication. Since public relations seeks positive publicity for the organisation, public relations practitioners use traditional and new media channels to achieve their goals.

Because of the importance of the different media types, public relations practitioners must know their structures, functions and activities. They must also know how to deal with the various media and be aware of their expectations.

It is important to note that, while traditional methods of communication are still common, modern technology has become a valued resource in reaching the external target audience. Organisations create websites to make people aware of who and what they are. Social media platforms such as

House publication:
a publication reporting events in an organisation, aimed at employees (internal) and groups outside the organisation (external)

New media also reach a mass audience, but do so via digital and social media platforms such as Facebook, Twitter, blogs, chat rooms, online forums, etc

Facebook and blogs are an easy way to reach target audiences and are a cost-effective means of building the organisation's image. Technology is far-reaching and allows the organisation to communicate with audiences all over the world.

External communication is an effective way to reach out to the public, but it has its challenges. The public opinion of an organisation can define the success or failure of the organisation in the long run. One misplaced quote, or badly worded newsletter, will not only ruin an expensive external communications plan, but also has the potential to affect corporate revenue. Interactive technology has the potential for public backlash, such as negative comment postings on Facebook. Public relations practitioners need to be aware of their audience and the organisation's image that they wish to convey.

Though new media has opened doors for direct interaction between the public relations community and its target audience, it is still an area that needs to justify its appropriateness in current public relations practice. Traditional and social media both have roles in public relations. It is important to understand these roles and learn how to use them in your public relations efforts (Nation 2014).

The role of the public relations practitioner



Exercise

Describe, in your own words, the role of public relations in an organisation. Compare your description with the discussion that follows.

Technical, management and strategic roles

A public relations practitioner fulfils three roles in an organisation: that of a technician, a manager and a strategist. What does this imply?

Technical role

The public relations practitioner's technical role relates to many of the techniques of public relations and is focused on the public relations role in: writing articles and media releases; collecting, editing and writing reports and articles for internal and external

house magazines and annual reports; page layout; preparing audiovisual presentations; photography; media liaison; and so on.

To embrace new media, public relations practitioners will need more technical skills in areas such as web publishing, new software operations, online security, search engine optimisation, web analytics and web trend analysis software operation. They will need enhanced online information architecture skills and skills related to managing and increasing the amount of complex information digitally. Writing for cross-media delivery will continue as a major component of practice but the demands for multimedia elements will bring even more challenges in the area. With the increased use of multimedia and interactive content in media releases, public relations will be producing this material and the skills bases must be adapted to accommodate these new demands (Kaul nd).

Management role

The management role refers to the advice and guidance the public relations practitioner gives to management on certain issues. For example, the public relations practitioner is best qualified to identify the most appropriate media to use for an important public announcement. To fulfil this role satisfactorily, it is imperative that the public relations practitioner has sufficient knowledge of the different media available and also knows how to approach them. Opportunities for the organisation to get positive publicity often arise. If the media is not approached and used correctly, these opportunities may be lost.

Strategic role

Finally, the role of public relations is also a strategic role. Public relations needs to contribute to the overall organisational goals and strategy. The public relations practitioner needs to write the communication strategy for an organisation. Through stakeholder relationships, environmental scanning and issues management, the public relations practitioner needs to be able to map trends and create a strategic direction for an organisation's identity and image management. This is based on analysis of societal and industry trends as well as the mission, vision (also part of the organisational strategy) and business strategy.



Take note

Since the technical aspects of the public relations practitioner's job align most closely to the journalistic skills needed by the public relations practitioner, the focus in this book is on the public relations practitioner's technical role.

B

Journalism

Definition of journalism



Exercise

Describe, in your own words, the meaning of the term journalism. Compare your description to the one given below.

Journalism is the practice of investigating and reporting events and information to a mass audience through the use of media. (What is Journalism? nd).

Journalists work at newspapers, magazines or for TV or radio stations, which are the traditional forms of mass media. Today, journalism also includes reporting information online, whether it be for a website, blog or social media platform (What is Journalism? nd).

Although this definition describes the essence of journalism, there is much more to the profession than meets the eye. Journalism involves various activities, but two of the most important are gathering information and writing. Journalists need to develop a sense for news and should be able to generate news stories on their own, in addition to the news stories that are assigned to them.

Journalism presents in the following forms (Niles 2014):

► News

- **Breaking news:** telling about an event as it happens
- *Feature stories:* a detailed look at something interesting that is not breaking news
- *Enterprise or investigative stories:* stories that uncover information that few people know

► Opinion

- *Editorials:* unsigned articles that express a publication's opinion
- *Columns:* signed articles that express the writer's reporting and his or her conclusions

- *Reviews*: such as concert, restaurant or movie reviews
- ▶ In its online form, journalism can come in the forms listed above, as well as the following:
 - *Blogs*: online diaries kept by individuals or small groups
 - *Discussion boards*: online question-and-answer pages in which anyone can participate
 - *Wikis*: articles that any reader can add to or change.

The purpose of journalism

The purpose of journalism is to educate and inform the public with relevant, accurate and timely information. People want to gain knowledge and become aware of national and international events. The media satisfy these needs most appropriately because of the variety of information they convey.

How do the mass media go about reaching the public? The media employ full-time journalists to fulfil this function, but also use freelance journalists. A freelance journalist is a person who does not work for a specific media organisation. These journalists gather news using their own initiative and present newsworthy reports to various media who then pay them for their contributions. The media receive further information from several national and international *news agencies*. These include the South African Press Association (SAPA), Reuters, Sky News, Cable News Network (CNN), etc. Journalists often rewrite or change these news items before presenting them in the style of their medium.

News agency: employs journalists who gather a wide variety of news for distribution to national and international mass media



Take note

Journalism concerns itself with informing the general public, whereas public relations is **all** about informing internal and external target audiences.

The role of the journalist

How do the media gather news? The central media figure is the journalist. The media use trained journalists to gather and present newsworthy information.

A journalist or reporter's (the terms are synonymous) main responsibility is to identify and gather newsworthy information and to present it in a clear and understandable way through the media (print, electronic or digital). The journalist's aim is,

therefore, to convey important information to the general public using the traditional or digital mass media as channels of communication.

Journalists receive instructions from the news editor, but also gather news using their own initiative. Normally, they keep a list of possible sources. Journalists gather information in several ways, including personal or telephone interviews, *media releases* and *media conferences* and social media platforms. They use three primary tools to gather information for stories:

- ▶ *Observation*: watching and listening where news is taking place
- ▶ *Interview*: talking with people who know something about the story that they are reporting
- ▶ *Documents*: reading stories, reports, public records and other printed material.

The people approached or documents used when gathering information are called sources.

Journalists need good interviewing skills to ensure that they elicit the correct information for publication or broadcast. They also need proficient writing skills and should be conversant in all aspects of the language in which they present their reports. Having obtained the facts, they present or write the report in an objective and unbiased manner. (The ways in which journalists gather information and present reports for the various media are discussed in later chapters.)

Journalists' work is of such a nature that they are not bound to the office or normal office hours. They need to go out regularly to cover events in their effort to obtain information. They can, however, also conduct interviews telephonically or use software applications such as Skype for video calling. This is not ideal as the journalist visiting the scene of an event gathers more information. This enables them to get a first-hand account of what is happening and connect with people at the scene. Whichever way they gather their information, journalists usually work under great pressure to meet their medium's deadline.

Although the print media employ professional photographers, it often happens that journalists themselves take photographs to accompany their reports or articles. A cameraperson accompanies the television journalist to capture footage.

Media release:

information concerning newsworthy events in an organisation, written in a specific format by a public relations practitioner and issued to the media. There are various ways to refer to a media release, namely a press release or a news release. We use the term 'media release' because it covers all aspects of media, not only newsworthy information.

For example, if there is a feel-good story that is done via a release, it is not newsworthy, but is still considered a release.

Media conference:

issuing newsworthy information to a gathering of media representatives

Beat: a specific field or area covered by specialist reporters, eg crime or sport

The style and nature of the different media mediums determine the manner in which journalists execute their duty. For example, a journalist at a small, local newspaper may be responsible for news reports varying from front-page lead stories to back-page sports news. They sometimes lay out pages in addition to writing the copy and taking photos. Journalists at a large daily newspaper may have their own *beat* and be responsible for only political, court or sports reporting, etc.

Journalism usually implies one-way communication conveying information to the general public, be it readers (newspapers, magazines, etc), viewers (television) or listeners (radio). However, letters to the editors in the print media and phone-in programmes or panel discussions in the electronic media establish two-way communication channels.

The impact of social media on traditional sources of information (mass media) requires a transformation for the journalist from being the gatekeeper of information to sharing that information in a public space. Social media has introduced a new dimension to journalism. People are no longer interested in being told what to watch and read – they want to choose what they read. Information is also no longer a one-way exchange. Social media is introducing interplay between traditional media outlets and the tweeters, bloggers and video posts supplementing their coverage, and is uncovering under-represented topics and stories in the mainstream media (Dineva nd).

With the advent of technology, a new form of journalism has come to the fore: that of citizen journalism. There are many definitions of this type of journalism but in its simplistic form it is about normal citizens performing some journalistic functions. For example, when normal citizens are able to capture an event using technology such as a smartphone and a media outlet then uses their pictures or videos as a first-hand account of the event, it is citizen journalism. Let's say you are a bystander after a building has just collapsed and no one can get to the scene. You use your cellphone to take video footage or photographs of the scene, which you post on YouTube or allow a media outlet to use. This is considered citizen journalism.

However, it must be understood that social media is not replacing journalism and usurping the role of the traditional

media platforms – rather, it is reshaping the role of journalism by illuminating and expanding news and providing new perspective and commentary. Social media platforms are a great way for journalists to connect with the public on an unprecedented level. Professional journalists can share their work through Facebook, Twitter and YouTube with an expanded audience as people have the opportunity to share news with their online circle of friends and family immediately. There is an authentic opportunity for dialogue and responsiveness through comments, which increases the likelihood of readers remaining loyal to specific media outlets (Dineva nd).



Duties of the two professions – public relations and journalism

Now that we have briefly discussed the definitions, roles and purposes of the public relations practitioner and the journalist, let us look at their duties.

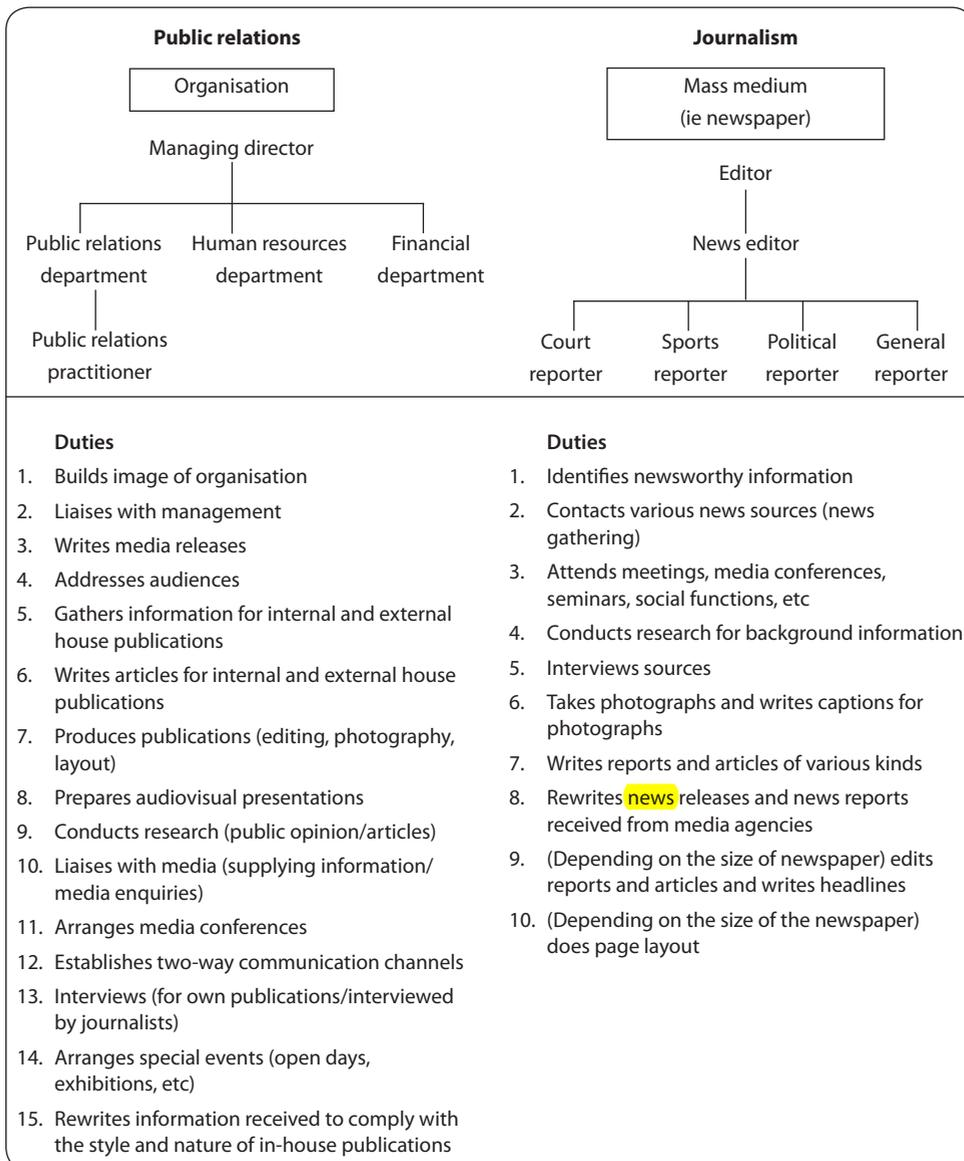

Figure 1.2 The duties of public relations practitioners and journalists

Summary

This chapter provides a broad overview of public relations and journalism to enable you to differentiate between the purposes and roles of the public relations practitioner and the journalist. The main aims of public relations are to build the image of an organisation and to establish effective two-way communication channels with internal and external target audiences. The public relations practitioner fulfils a technical, management and strategic role in the organisation. The technical role corresponds with skills applied in journalism.

Journalists gather newsworthy information and present it in an understandable way to a large audience through the media. Journalism is directed at external target audiences. The role of journalism has changed because the mass media are no longer gatekeepers of new content. Our social networks have become those gatekeepers.

Test yourself

1. Define the term public relations.
2. Define the term journalism.
3. What is the purpose of public relations? List the three roles that the public relations practitioner plays in an organisation, and give a brief explanation of each.
4. What is the purpose of journalism?
5. Explain the role of the journalist employed by the media.
6. Which public relations role listed in question 3 corresponds with journalistic skills? Support your answer by providing reasons.

Combining public relations and journalism in Media Studies



Objectives

After you have studied this chapter, you should be able to:

- discuss how public relations and journalism interact with each other
- discuss in detail how the public relations practitioner applies journalistic skills in executing his/her technical role.

Introduction

It is clear from Chapter 1 that public relations and journalism are two unique professions. In this chapter, you will see how they depend on each other to fulfil their daily tasks.

As part of their technical role, public relations practitioners deal with the media. Public relations practitioners use the media to obtain positive *publicity* for their organisations. They supply journalists with newsworthy information for *publication* or *broadcasting*. Conversely, journalists obtain a vast amount of news of public interest for the media from public relations practitioners in different organisations.

There are two types of media exposure – controlled and uncontrolled. Controlled exposure is when you pay for the media exposure and uncontrolled exposure is when the media use information about your organisation. If, for example, you pay for a corporate advertisement or advertorial, it is controlled exposure. You have control over where, when and how your advertisement will be placed. If you are simply submitting

Publicity: when something is noticed or given attention on a public platform, such as by the media

Publication: information printed in newspapers or magazines

Broadcasting: information aired to listeners (radio) and/or viewers (television/Internet)

information to the media that you would like published or broadcast, the staff of that media outlet have control over whether to use it and where and when to use it. On the other hand, if a major event happens and the media outlets use information on your organisation, this would also be deemed uncontrolled exposure (Nel 2005: 256–257).

Interaction between public relations and journalism

The key concepts for understanding the interrelationship between public relations practitioners and journalists are truth, trust, integrity and transparency. These are central to their professional activities. Both the journalist and public relations practitioner are dealing with matters of public interest and need to co-operate, but at arm's length (Davies 2008). Both professions have a significant influence on the modern world.

Public relations practitioners need the media to publish or broadcast organisational information to obtain positive publicity and to make the organisation known to the public. How do they do this?

Media relations is one of the key functions of public relations. This involves having relationships with the media and ensuring that your organisation's information finds placement within the media. Public relations practitioners should know how the various media function and who they should contact to convey information. (See Part 2 for a discussion of this aspect.)

The public relations practitioner issues newsworthy information in various ways to the media – for example, through a media release. Journalists will rewrite the media release to suit their specific medium's *style* and *nature*. Therefore, the better you as a public relations practitioner can use the style of the medium through which you are sending the media release, the better chance you will have of it being published as you intended. Public relations practitioners also arrange media conferences at which journalists gather to receive information first-hand. The media conference also gives journalists an opportunity to raise specific questions. Public relations practitioners can also disseminate news through e-mail, personal contact or telephone/video conference interviews with journalists. It is important that public

Media relations: centred around the symbiotic relationship between a public relations practitioner and a journalist. It is the systematic, planned, purposeful and mutually beneficial relationship between journalists in the



mass media and the PR practitioner. Its goal is to establish trust, understanding and respect between the two groups

Style and nature: a specific way of writing or presenting information for different media (print or electronic)

relations practitioners know the needs of the different media to improve their chances of publication or broadcasting. (Print and electronic media requirements are discussed in Part 2.)

It is clear from the above that public relations practitioners will not get mass media coverage without the help of journalists. At the same time, public relations practitioners greatly assist journalists in obtaining news. Journalists might contact employees at an organisation for information. However, this is not a healthy situation because employees are not trained to deal with the media. It is therefore important that public relations practitioners make themselves known to journalists as their organisations' official spokespeople. Public relations practitioners, therefore, act as links between the organisation's management and journalists.

Often there is tension between public relations practitioners and journalists. Reasons for this include public relations practitioners being unavailable or not being competent to issue information. In these cases, journalists often contact other employees for information. It is the duty of public relations practitioners to deal with the media on behalf of management. Journalists should also know that public relations practitioners should be their first contact for information. Journalists who need to interview an organisation's employees should still use the public relations practitioner as their first contact. The public relations practitioner will arrange the interview.

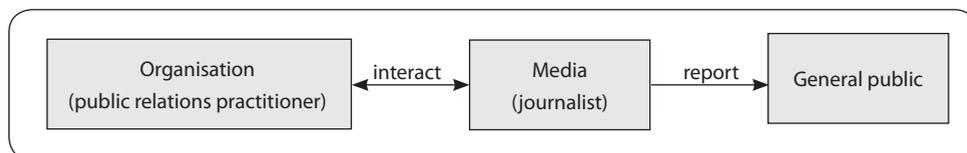

Figure 2.1 The interaction between public relations and journalism

If we review the duties of public relations practitioners and journalists listed in Figure 2.1, we should be able to get a clearer picture of how they work together.



Exercise

Refer to Figure 1.2 in Chapter 1, which lists the duties of public relations practitioners and journalists. List the duties that you think illustrate their interaction. Then compare your list with the list of duties that follows.

Public relations

- ▶ writing media releases
- ▶ liaising with the media by:
 - supplying information and acting on enquiries
 - arranging media conferences
 - granting interviews to the journalist.

Journalism

- ▶ rewriting media releases received from the public relations practitioner
- ▶ identifying newsworthy information by contacting the public relations practitioner who acts as news source
- ▶ interviewing the public relations practitioner
- ▶ attending media conferences, meetings, seminars, etc, to gather information.

Interact: the public relations practitioner gives information **to** the journalist or the journalist seeks information **from** the public relations practitioner



The above exercise illustrates how public relations and journalism *interact* to inform the general public about newsworthy events.

Journalistic skills needed by the public relations practitioner

In the previous section we saw how public relations and journalism work together. In this section we focus on the journalistic skills that public relations practitioners need to fulfil their technical roles.

Before we discuss the journalistic skills applied in public relations, do the following exercise to see if you can pinpoint these journalistic skills.



Exercise

Use the list of public relations and journalistic duties in Chapter 1 (Figure 1.2) for this exercise. Compare the duties of public relations practitioners and journalists. List the duties of public relations corresponding to those of journalism to determine the journalistic skills required for public relations.

For example:

Public relations practitioners: *Gather information for internal and external house publications*

Journalists: *Contact various news sources (news gathering)*

Here we see that the journalist identifies newsworthy information and uses various news sources to gather information. The same skill is applied by the public relations practitioner in gathering information for organisational publications.

Now, by following the above example, determine what other journalistic skills are applicable in public relations. Compare your list with the skills given below.

Public relations practitioners

- ▶ conduct interviews
- ▶ take photographs
- ▶ write articles for their own publications
- ▶ produce publications that require editing, page layout, photography
- ▶ conduct research for articles
- ▶ rewrite information received to comply with the style and nature of in-house publications.

When compared with journalists, we find the following corresponding duties:

- ▶ interview sources
- ▶ write news reports and articles
- ▶ edit news reports and articles
- ▶ do page layout
- ▶ take photographs
- ▶ conduct research for background information
- ▶ rewrite media releases and other stories received from sources.

What is significant about this list? Have you noticed that most of the skills applied in journalism – especially from the print media – are needed in public relations?



Take note

The above similarities show how strong the link between public relations and journalism is. It shows how important journalistic skills are for the public relations practitioner who establishes publications for internal and external use. *The following example shows how public relations practitioners use these journalistic skills.*

Public relations practitioners need to publish an internal house magazine. They identify newsworthy information and contact various sources for this. Research is done to obtain background information and interviews are conducted to gather further information. They then write the articles and rewrite other contributions. Photographs they have taken accompany certain articles. They edit all reports, articles and photographs, and arrange them for page layout. They then do the page layout for the various reports, articles and photographs. This is done manually or with the help of a desktop publishing program. (How public relations practitioners acquire these journalistic skills is discussed in Part 3.)

Our example of journalistic activities concentrated on the print media (newspapers/magazines) where most of the journalistic skills required by public relations practitioners are applied. When comparing the activities of journalists from the print media with those of the electronic media – namely, radio and television or digital media such as social media or websites – there are still many similarities, such as research, news gathering, interviewing, editing, writing, etc. The difference, however, is in the way in which journalists from different media handle and present their news reports. For example, television interviews and reports are edited digitally and combined with text written for the newsreader. In Part 2, where the various media are discussed, we look more closely at how journalists from these different media handle and present their news reports.

Summary

In this chapter, we have seen how public relations and journalism interact with each other. We have shown how public relations uses journalism to convey information to the general public and how journalism uses public relations to obtain news of public interest. The public relations practitioner acts as a link between the organisation and the journalist. To ensure that their facts are correct, journalists should contact an organisation's public relations practitioner and not other employees.

Many similarities exist between journalistic skills applied by the journalist and journalistic skills applied by the public relations practitioner. The journalist applies these skills to have newsworthy events published or broadcast to a diverse, general public. The same skills applied by the public relations practitioner enable him or her to produce internal publications aimed at employees and external publications aimed at specific target audiences.



Test yourself

1. Give reasons why journalism forms an important part of Media Studies for the public relations practitioner.
2. Explain how public relations and journalism interact with each other. Give appropriate examples.
3. Explain why the public relations practitioner needs journalistic skills and give an example of how these are applied in public relations.
4. Discuss the skills needed by both public relations practitioners and journalists.

News and public relations



Objectives

After you have studied this chapter, you should be able to:

- define the term news
- list the characteristics of news
- understand news values
- discuss the types and categories of news
- identify appropriate, newsworthy issues in an organisation for the mass media
- identify appropriate, newsworthy issues in an organisation for internal house (in-house) publications
- identify news sources appropriate in certain situations for the:
 - ▶ journalist; and
 - ▶ the public relations practitioner.

Introduction

In Chapter 2, the importance of the interaction between public relations practitioners and journalists became clear. It is also clear that this interaction is ongoing and that a sound relationship between public relations practitioners and the media is invaluable.

One of the main results of effective interaction between these two professions is the benefit that both can derive from it, provided that it is handled correctly. Publishing news of an organisation in the media accomplishes two objectives:

- ▶ Media publicity is enjoyed by the organisation.

- ▶ An opportunity for the journalist/media to provide fresh, important or interesting information (news) to the public is realised.

The public relations practitioner acts as an important source of news to the media by providing timely information about newsworthy issues. But, consider the following:

- ▶ **HOW** do public relations practitioners know what is newsworthy?
- ▶ **WHERE** do they look for news?
- ▶ **HOW** do they identify newsworthy issues?
- ▶ **HOW** do they establish to whom and how this news should be conveyed?

The answers to these questions are important to public relations practitioners. Once accustomed to finding news and dealing with the media, they will be able to identify and channel news correctly to the various media with the most effective results.

In this chapter, we look at what journalists regard as news. We also establish the characteristics, types and categories of news. We then explain how public relations practitioners can apply this knowledge to identify news in their organisations. In the last part of the chapter, we discuss the various ways in which news is identified and how information is gathered by journalists and public relations practitioners.

Part 2 of this book deals with how the public relations practitioner decides to whom and in what fashion the news should be conveyed.

What is news?



Exercise

Describe, in your own words, what news is. Compare your answer with the following: Definitions of news vary from 'news is what newspapers publish', to 'news is what the public wants to know'. Hough (1995: 1) says:

News is what people need or want to know, whatever interests them, whatever adds to their knowledge and understanding of the world around them. News is also what a reporter or an editor at any particular moment considers interesting or exciting or important – something that the reporter or editor thinks will interest or be useful to readers.



Take note

In the light of these observations, we can formulate our own general definition of news, namely:

News comprises current issues or events that have credibility and are important or of interest to the public.

Characteristics of news

Although definitions of news vary considerably, one or more of the following *characteristics* will always be present:

- ▶ News is *new* (when one is made aware of an issue or event for the first time) or it will add a new *angle* or perspective to already known information.
- ▶ News is *interesting* and/or *important*.
- ▶ News is *credible*.

Characteristics: typical or distinct attributes of newsworthy events

Angle: a written news report's focus or point of departure

Further criteria determine the newsworthiness of an event. It must be different, unique or exceptional in some way. Think here in terms of something tragic, strange, ironic, unusual, the latest, most expensive, controversial, pioneering, important, significant, etc.



Exercise

Choose two news reports from any newspaper or television/radio news bulletin. Identify the newsworthy characteristics of the report. Motivate why you regard the reports as newsworthy by explaining the characteristics you have found.

News report 1	
Characteristic	Motivation
News report 2	
Characteristic	Motivation

News values

What makes one story more newsworthy than another? In media terms, we refer to this as news values – a checklist of sorts that helps determine the newsworthiness of a story.

News values are general guidelines used by media outlets such as newspapers or broadcast media, to determine how much prominence to give a story. It is about necessary information and unusual events, should be based on observable facts, should be an unbiased account and should be free from the journalist's opinion. (Spencer-Thomas 2013)

What happens in the selection of news stories? Lieb (2009: 26–27) identifies the following basic news values: impact, prominence, currency, conflict, timeliness, unusualness, proximity, affinity and human interest.

Impact

The primary measure of the value of any information is its impact or effect on the audience. The more people a story affects, the better the story. For example, an increase in the price of petrol in South Africa would have a direct impact on all South Africans. But a flood in Johannesburg will only have an impact on the people living in the area and on those who may have family or friends living there. This is known as indirect impact. However, should the floods cause great damage to the maize crop, it could also indirectly affect many more people (because of possible price increases).

Journalists believe that direct impact is the most important aspect of newsworthiness.

Prominence

Stories with prominence are stories involving well-known places, companies, groups or people, especially celebrities. As we know, names make news – the bigger the name, the bigger the news. Celebrities, politicians and other famous people catch the attention of the public. Think of the death and the funeral of the iconic Nelson Mandela. Due to his prominence, this story generated millions of viewers worldwide.

However, too much focus on prominence can lead to overblown coverage of the insignificant actions of minor celebrities. Think of some of the reporting from Hollywood when a celebrity takes his or her dog for a walk or some other meaningless activity that still generates publicity because of the individual's prominence.

Currency

Currency, or flavour of the month, describes events and situations that are currently in the news and being talked about. Think about a World Cup event such as soccer, rugby or cricket. People talk about it and it is all over the news. It is current but, when it is over, the news dies down and all is forgotten.

Conflict

Most interesting news stories are based on some sort of conflict: people battling nature, war, disease, etc. Stories about political conflicts, war and crime are the more popular news stories. Conflict is found in stories about people or organisations at odds with each other. Information has conflict if it involves some kind of disagreement between people. Think here of the battle between government and the unions.

Timeliness

News must be fresh – today's news is stale tomorrow. It's timely when it happened recently. With today's online newsrooms, stories are continuously updated; thus, print editions need to ensure that their information is current at the time of publication.

Unusualness

News stories tend to focus on things that are out of the ordinary, unusual or strange. Unfortunately, unusualness can lead journalists to ignore important stories and focus instead on insubstantial ones. For example, a story about a baby born with a physical deformity is more likely to get coverage than the thousands of people in that same community who do not get prenatal health care, which leads to infant deaths.

Proximity

This refers to physical nearness. People like to read or hear news about people and events that are close to them. The closer an

issue or an event is to the readers, the greater its impact and news value. For example, we will be far more interested in coverage of the South African elections if we are South African and living in South Africa than we would of the French elections.

Affinity

People are interested in other people who share characteristics or have an affinity with them (religion, nationality, culture and so on). For example, stories involving the pope would be considered more newsworthy in an area with a significant Roman Catholic population or to Roman Catholics than in an area primarily populated by a Buddhist community.

Human interest

Stories that have a strong emotional content are said to have human interest. Some, like the miraculous survival of Thandi the rhino after a horrific horn poaching at Kariega Game Reserve, make the audience feel good and help to offset heavy and often downbeat news. This is also sometimes valued too highly, leading to important stories being pushed out of the news by emotional stories of less consequence.



Exercise

Read through the articles in the front page of any newspaper. Make a list of the news values you find in each article.

Types of news

We distinguish between two main types of news, namely hard news and soft news. Hard news stories are of a current and immediate nature and are usually found in the more important pages of a newspaper. Hard news stories carry important news, especially of a political, economic or crime-related nature. They also cover traumatic stories or events affecting media consumers, eg changes in the government, petrol price increases, mass murders, natural disasters, etc. These stories are usually of a serious nature and are of regional, national and/or international importance or interest.

Soft news stories include features that lend a human perspective to hard news. They are 'follow-ups' to hard news stories, eg political, economic and crime stories, focusing on their human dimension. Humorous stories, 'women's page' stories, art stories, etc, are examples of soft news.

A television news bulletin will begin with hard news stories on violence, crime, political issues and so on, and end on a lighter note with a story on, for example, the successful rhino breeding programme in the North-West Province of South Africa that saw five new rhino calves being born on a particular day. Many newspapers also carry a story in a lighter vein on the front page to break away from the hard news, although this is usually only a small section of the page.



Exercise

Take any newspaper and choose a hard news story and a soft news story. Summarise the content of each story and motivate your choice for each.

It is also necessary to know that we distinguish between scheduled and unscheduled news and expected and unexpected news. These differences can be explained by the following examples:

- ▶ The public relations practitioner invites journalists to cover an expected event, eg to come and see the five new rhino calves born in the North-West breeding project. Journalists and public relations practitioners schedule the date and time of this event.
- ▶ An underground explosion at a mine or the collapse of a new building in the Sandton CBD is unexpected and is therefore unscheduled news. The explosion and building collapse are unpredictable and the journalist cannot schedule the events.

Categories of news

News is also classified into different *categories*. The media apply these categories differently. Think of the time slots given to sport and weather in a television news bulletin and compare them with the news distribution in a daily newspaper.

Categories: classifications of newsworthy events

A few major news categories are as follows:

- ▶ *Politics*: news from Parliament, political leaders, local government
- ▶ *Finances*: stock exchange, gold price, annual budgets, major companies
- ▶ *Planning and development*: new schools, hospitals, dams
- ▶ *Sport*: soccer, rugby, tennis, cricket, netball
- ▶ *Weather*: first snow in winter, severe drought, flood
- ▶ *Crime*: murder, robbery, fraud
- ▶ *Emergencies*: disasters, tragedies
- ▶ *Human interest*: people, animals
- ▶ *Personalities*: public figures such as members of Parliament, the captains of sports teams, etc.

News can also be categorised into events or issues of local, regional, national and international interest. The main theme of an event or issue will determine its news category.

Now that we know how to identify newsworthy events by observing the characteristics, types and categories of news and news values, we will discuss how this relates to public relations.

Public relations and news

Why is it important for the public relations practitioner to know what news is? This knowledge will enable the public relations practitioner to guide management not only in disseminating information of importance to the media, but also by contacting the media at the right time for the right reasons. It is also important for the public relations practitioner to track trends within his or her society and the organisation's industry so that he or she can do trend analysis and also manage possible issues that may arise in the sector. For example, if you work for a mining consortium and you see in the news that there are planned sector-wide strikes, you can start making contingency plans to crisis-manage this situation.

Every day the media is inundated with information from public relations practitioners. Unfortunately, too often it happens that much of this information cannot be used. The main reason for this is that public relations practitioners are often uncertain or do not know what the media considers newsworthy. In conveying

information to the media, the public relations practitioner must ensure that the information is newsworthy and of public interest. For example, if a sports team changes its corporate identity, such as its uniforms and logo, this is newsworthy and of public interest, and should be conveyed to the media. In contrast, the promotion of a junior administrator in the offices of this sports team to the rank of senior administrator would not be of public interest and should not be conveyed to the media. However, if the team is well known, the appointment of a new captain would be considered newsworthy.

Although the aim of public relations practitioners is to get publicity for their organisation, they must guard against pressure from management to inform the media of general issues and events for the sake of publicity only, ignoring the story's newsworthiness.



Take note

Taking cognisance of what news is will enhance management and the public relations practitioner's professional approach to disseminating newsworthy information to the media. By not being able to distinguish between what is newsworthy and what is not, they will develop an unfavourable reputation with the media.

Public relations practitioners should know that journalists are able to obtain information from several sources. If the public relations practitioner does not act proactively and inform journalists of events immediately, chances are that the journalist will obtain the information elsewhere. The public relations practitioner will then have to act reactively in giving the organisation's side of the story.

Public relations practitioners should not wait for journalists to contact them for information – they should break news to the media immediately. Should there be a strike at an organisation, the public relations practitioner should immediately make the media aware of the situation. By waiting for journalists to initiate contact, the assumption could be drawn that the organisation is hiding facts regarding the strike and journalists may try to get their information from employees. A timely *tip-off* to journalists can benefit media relations.

Tip-off: information received, often anonymously or by someone close to a given situation, that could lead to a news story

Public relations practitioners should also be aware that various media value news differently. For example, toxic waste from a plant threatening nearby residents' lives will be front-page news in the local newspaper. The level of toxicity and the threat posed by the waste will determine the news value that a daily newspaper ascribes to the report. Depending on the seriousness (newsworthiness) of such an incident, it might be included in a radio news programme, or even a television news bulletin. For example, it could become major news if someone dies or a whole community gets sick. When disseminating newsworthy information to the media, the public relations practitioner has to choose the correct medium for the message.

Remembering that the public relations practitioner is responsible for conveying organisational information to internal and external target audiences, the following definition of news is appropriate to public relations:



Take note

News is information that is current, important and of interest to the specific public at which it is aimed, be it an external or general public interested in general, everyday news or an internal public (employees) demanding its own, distinct type of news.

Target audience (external and internal) for the public relations practitioner

Target audience in the general public

Who is the general public? This public consists of everybody out there. In other words, in conveying information through the mass media, the intention is to reach a wide range of people, from schoolchildren to high-ranking government officials or businesspeople.

Various stakeholders important to the organisation are identified in the general public, eg clients, communities and opinion leaders. These stakeholders can be reached by means other than the media when specific messages need to be conveyed to them. External house magazines, annual reports, etc, are used for this purpose.

The general public, as an external target audience, is important to the public relations practitioner because the public shapes opinion of the organisation.

Public opinion

Public opinion is formed by what the general public reads, hears and sees about an organisation in the media. Although the main aim of public relations is to build a positive public opinion of the organisation by having positive news published or broadcast in the media, it is also necessary to face any negative news about it. By keeping the media informed about both good and bad news, the public relations practitioner will gain more credibility with the media and, ultimately, the general public.

The honest revelation of facts about the organisation through the media will have positive, long-term benefits.

Employees as the internal target audience

Public relations practitioners should bear in mind that they are also responsible for identifying internal news and that, although certain issues are not valued by the media and the outside public, they are important to the internal target audience.

Employees need a distinct type of news. Hardly any news communicated internally through the in-house newsletter reaches the media, even though it is important news to the internal public. In identifying news for employees, the same criteria that apply to the media apply to internal publications. Employees want to read a publication containing new information (or additional new information) that is interesting and important. Hard and soft news stories should be included. In categorising the information, public relations practitioners should be satisfied that they have provided the employees with a wide range of newsworthy information.

Any news about an organisation will interest employees. Matters concerning policy, internal structures, rules, regulations, general company issues, as well as interesting and successful employees, are important news and should be communicated to employees. The media might find issues such as the visit of an important overseas dignitary to the organisation interesting enough to publish or broadcast.



Take note

It must be remembered that all information should be communicated to employees before it is conveyed to the media.



Exercise

Look at the following examples of organisational events. Choose items that you consider to be of importance or interest to the readers of:

1. an internal newsletter (employees only); and
2. the mass media (general public).
 - a. crèche facilities for employees' children
 - b. the appointment of a new executive director
 - c. the discovery of fraud in the company
 - d. the imminent opening of a new branch
 - e. the destruction of an important section of head office
 - f. negotiations and a possible takeover of a similar organisation abroad
 - g. the annual award ceremony for employees
 - h. the organisation's annual sports day
 - i. the election of a new committee for the organisation's social club
 - j. a strike by employees due to a salary dispute
 - k. a visit by a foreign dignitary to an organisation
 - l. an improved medical aid scheme for employees.

News sources

Now that we have discussed various facts about the meaning of the term news, the following question must be asked: Where do we find news?

News sources: sources used to identify and/or gather information of news value

This question brings us to the importance of *news sources*. To enable us to identify news and to obtain facts and information needed to write or present the news report, we need reliable news sources.

News sources are indispensable to journalists and public relations practitioners searching for news and information. Without these sources, factual and correct information will be difficult to find.



Take note

Although there are many news sources available to the journalist and the public relations practitioner, the most important thing to remember is that each incident, event or issue will determine the relevant news source.

In this section, we will look firstly at the general news sources useful to the journalist and secondly at the news sources useful to the public relations practitioner.

News sources for journalists of the mass media

The journalist finds hints for possible news stories from various areas. All journalists have a list of established contacts that they use to find news stories and gather information, eg the police, the fire brigade, the traffic department, hospitals, government departments, transitional council offices, etc. Although the public relations practitioner of the specific institution usually acts as the spokesperson (this is advisable), journalists may have other contacts in these institutions. Public relations practitioners will often find this to be the case, and it is very difficult to control.

Journalists also get news tips or tip-offs from members of the public, from employees of organisations and from emergency radio services. News reports carried by other media can also be followed up in an effort to obtain a new angle to a story.

Apart from news stories assigned to them by the news editor, journalists use several other sources for stories. These include:

- ▶ public meetings or speeches
- ▶ media conferences
- ▶ media releases
- ▶ annual reports/budgets
- ▶ social media
- ▶ social functions
- ▶ news agencies, eg Associated Press (AP) and South African Press Association (SAPA).

Once a news story is identified, journalists make use of every possible source to obtain adequate and accurate information.

Eyewitnesses, spokespersons of organisations, members of the public, emergency services, pressure groups, etc can all be considered major sources of news. If this is not sufficient, they might use additional source material, including:

- ▶ court reports
- ▶ media reports
- ▶ public records
- ▶ databases/archives
- ▶ libraries
- ▶ museums
- ▶ press clippings
- ▶ other publications
- ▶ social media platforms
- ▶ the Internet.

The following example illustrates the use of news sources by a journalist:



Example

A luxury cruise liner is sinking off the coast of Durban. It can be seen from the pier close to the harbour since the cruise liner only left the harbour this morning. The first reports have come in from a National Sea Rescue Institute report that was issued. The news is identified. The sources a journalist may use to gather information for the news report include:

- spokesperson or public relations practitioner from the organisation that owns the cruise liner
- emergency services (National Sea Rescue Institute, ambulance, fire brigade, rescue teams)
- the police investigating officers
- relatives of the passengers
- eyewitnesses near the scene
- social media reports – often at scenes people upload videos and photographs, even sound clips
- hospitals receiving injured passengers
- survivors.

Because public relations practitioners act as very important news sources for journalists, we need to see how they can assist the journalist in identifying news and gathering information on a specific organisation.

The public relations practitioner as a news source

Public relations practitioners act as news sources for the media in several ways, the most common of which is issuing media releases to the various media. Another way is to arrange a media conference if the event, incident or situation warrants it. Information is also conveyed through personal (face-to-face), telephone or video-conference interviews with journalists. Public relations practitioners gain publicity for the organisation in their role as news source, which, unlike advertisements, is free.

It is important to note that equipment, eg a telephone, is a resource (aid) used to reach a news source and not a news source. The same applies to an interview – it is the person with whom the interview is conducted who is the news source.

When acting as a news source, one of the most important lessons to learn is that public relations practitioners should never favour one journalist or medium. When publicising a newsworthy event, public relations practitioners must inform the journalists of all the relevant media simultaneously. It is up to the media to decide whether they are interested in the story.

There are, however, certain situations in which public relations practitioners should use their own judgement. For example, it might happen that a journalist hears of an incident in the organisation and approaches the public relations practitioner for comment. Perhaps, owing to the sensitivity of the incident, the public relations practitioner (in conjunction with management) initially had no intention of making the incident public knowledge. When approached for comment, public relations practitioners should not try to suppress information and should never say, 'No comment'.

In such cases, careful consideration should be given to whether the information will be relayed to that journalist alone or whether it will be made known to other media as well. Since journalists thrive on *scoops*, the decision might be taken to give the journalist his or her moment of glory before revealing the information to other media.

Scoop: first report of a news event

Once the information is publicised by the journalist, the public relations practitioner should have additional information ready for other journalists seeking a fresh angle to the story.

If the intention was to make the information known to the general media, the public relations practitioner should advise the journalist accordingly, so that the journalist is aware that his or her medium will not be the only carrier of the news.

News sources for the public relations practitioner

Now that we know from where and how the journalist gets news and how the public relations practitioner can act as a news source, we will look at the public relations practitioner's news sources. Keep in mind that public relations practitioners are only concerned with news relevant to their own organisations and that their duty is twofold, namely to inform their internal and external public about happenings in their organisations.

Many of the news sources used by journalists can also be used by the public relations practitioner. These include:

- ▶ databases or archives
- ▶ other publications
- ▶ libraries
- ▶ museums
- ▶ annual reports
- ▶ press clippings
- ▶ social media
- ▶ the Internet.

Sources used more often by the public relations practitioner include the following:

- ▶ own staff
- ▶ meetings
- ▶ minutes of meetings
- ▶ management
- ▶ internal publications
- ▶ former or retired employees
- ▶ other relevant organisations
- ▶ shareholders of the organisation.

The same criteria that apply to journalists apply here, namely that the event or incident will determine the sources used to obtain information. What is important for the public relations practitioner in selecting news sources is that the type of

organisation will also determine the sources that can be used. For example, a public relations practitioner at a hospital may have to gather information from patients (with patients' written consent) or a public relations practitioner in local government may find that information is needed from ratepayers, etc.

The following is an example of how public relations practitioners use news sources:



Example

A major hotel group plans to build a multi-million-rand hotel complex. The public relations practitioner may identify this newsworthy information in the minutes of a meeting and through discussions with management. The sources that the public relations practitioner can use to gather information for a media release include architects' drawings and presentations, financial statements, management's decisions and comments, etc.

These are some examples of sources that can be used, but public relations practitioners might find other sources relevant to their specific needs.

It is clear that in order to identify newsworthy events and to gather more information for internal and external house publications as well as for the media, the public relations practitioner uses several sources.



Take note

The public relations practitioner uses news sources to gather information for a media release or a media conference. Since these are ways in which the public relations practitioner acts as a news source for the media (as discussed in the previous section), media releases and media conferences are not news sources for the public relations practitioner. The only time the public relations practitioner can use a media release as a news source is when background information of an event was covered by an earlier media release(s).



Exercise

1. Select news sources suitable for the public relations practitioner searching for information about the organisations upcoming toy drive for abused children.
2. Select news sources that a journalist of a local, weekly newspaper can use to find three news stories for the week's edition. Identify the type of stories to explain your sources.
3. Select news sources a journalist can use to write a front-page story about the collapse of a mineshaft in which 12 workers are trapped.
4. Select news sources the public relations practitioner will use to write a media release about a staff member who was selected for the national soccer team.

Creation of news

In addition to using news sources to identify and gather information about a newsworthy issue, news can also be created. For example, the public relations practitioner can create opportunities for news stories by organising special events such as open days, exhibitions, functions, etc.



Summary

In this chapter, we described the term news as an issue or event that is current, interesting or important and of value to people. Two types of news were distinguished, namely hard news and soft news. There are several categories of news, eg crime, sport, etc.

The public relations practitioner's duty is to identify newsworthy events in the organisation that are of interest to the employees and/or the general public. Public relations practitioners use the media to convey information about their organisation to the general public and use internal publications to inform staff of events.

In the last part of this chapter, the various news sources that the journalist uses to identify news and gather information and the way in which these can be used by the public relations practitioner were discussed. Public relations practitioners are more limited in their choice of news sources than journalists,

since they are concerned only with news about their organisation. The event will, in each case, determine the sources used to gather information.



Test yourself

1. Describe the term news:
 - a. from a journalist's point of view; and
 - b. from a public relations practitioner's point of view.
2. Choose any two news reports from a newspaper report or a radio or television news bulletin.
 - a. Discuss the characteristics present in every news report.
 - b. Choose the types of news involved in each report.
 - c. Select the categories of each report.
3. Identify at least three different newsworthy events in an organisation that the public relations practitioner can convey to:
 - a. the general public through the media; and
 - b. the employees of the organisation through a newsletter.
4. A journalist has to write a news report on a train disaster in which several passengers were killed and many injured. List and discuss the various sources the journalist can use to gather information.
5. A public relations practitioner has to write an article for the organisation's internal publication about the appointment of a new managing director. List and discuss the various sources that can be used to gather information.
6. An organisation has recently received unfavourable publicity in the media. In an effort to change the negative image created to a positive image, the public relations practitioner decides to create an opportunity for news that will portray the organisation in a favourable light. Discuss how the public relations practitioner can create news that will attract the attention of the media.

Ethics in public relations and journalism



Objectives

After you have studied this chapter, you should be able to:

- explain the concepts of moral and legal ethics
- distinguish between right and wrong in your conduct towards others when practising public relations.

Introduction

Now that we have established the interaction between public relations and journalism, we need to pay attention to another very important aspect, namely *ethics*.

Public relations practitioners pledge their allegiance to their organisation, while journalists pledge their allegiance to the wider public. Both professions attempt to maintain integrity through honesty. Both professions must vie for the same audience attention and must conform to an ethical code of conduct and pledge allegiance, no matter what, to telling the truth (Kaul nd). Both professions must fulfil their moral and ethical obligations to the wider public by conforming to rules and regulations.

While growing up, we were taught the difference between right and wrong in our conduct towards others. While we tend to strive towards upholding our cultural values and moral principles when dealing with others, we also need to be aware of what is acceptable to the broader community. In our

Ethics: the science of morals; moral principles; rules of conduct

professions we constantly have to make decisions regarding our interaction with others and we usually base those decisions on what we feel is the correct one for that moment. However, this is where ethics plays a major role since decisions made could go against a prescribed code of conduct. Although different occupational groups have their own code of conduct or professional standards, they basically all point to one thing, namely to be credible to and respected by those with whom they come into contact. Communicators should encourage frequent communication and messages that are honest in their content and accurate and appropriate to the needs of the organisation and its audiences.

This section has online support material available.

You should become acquainted with the full scope of ethics in public relations (Code of Professional Standards for the Practice of Public Relations) as laid out by the Public Relations Institute of Southern Africa (PRISA). We will therefore not cover this issue in detail here.

The focus of this chapter is on the conduct of the public relations practitioner towards journalists. However, it is also important to remember that within public relations there is also the aspect of online ethics and legal awareness that needs to be considered. If you as a public relations practitioner represent your company online – whether through its Facebook page, website or Twitter handle – you also have to keep all the ethical principles that you learn in this chapter in mind. Just because the representation happens in a virtual space does not mean that ethical practice can be forgotten. Online practice is still bound by legal and ethical considerations that must be taken into account. Koonin (2013: 86) explains that it is about knowing online boundaries and adopting ethical practices in online spaces. This is also known as a digital footprint – a visible online record of all comments and other content posted on the Internet (Pritchard 2013: 1).

As a public relations practitioner, you should be as aware of the moral and legal ethical pitfalls in the media as the journalist is.



Take note

Moral and legal ethics are explained in detail later in this chapter. In short, moral ethics is concerned with goodness or badness of character or disposition, whereas legal ethics refers to rules recognised by law.



Exercise

Before studying the rest of the chapter, read through the following fictitious scenarios and answer the questions that follow (bearing in mind that the events in this scenario are very likely to occur in a real-life situation):

Scenario 1

Joan has been a senior member of the PR department at a large hospital for three years. As the head of the department has resigned, she is filling the role of acting head in the hope of being promoted to the permanent position fairly soon. Joan has enjoyed a good standing with management and is highly respected by the staff and the public for her integrity, trustworthiness, knowledge and skills. She also has excellent relations with the media and is well respected by them.

As a member of the management team, Joan attends all management meetings. One such meeting turns out to be one that Joan may well have preferred not to have attended at all. At this meeting, the Chief Executive Officer (CEO) of the hospital announces that a young patient died unexpectedly during the course of the previous night. Subsequent investigation revealed that the attending doctor may have been negligent and could be directly linked to the death of the patient. The doctor concerned, however, happens to be the CEO's brother, who is only three months away from retirement. The family of the patient, in the meantime, has been informed that the child had died of natural causes.

Management feels that disclosing the facts may cause the hospital to face negative media publicity, while the doctor could even face dismissal so soon before his retirement. For these reasons, along with other repercussions that may arise, they decide to keep a tight lid on this sensitive issue. They specifically request Joan not to divulge any of this to the media and should any journalist ask her directly, to deny any fault on the part of either the doctor or the hospital.

The following day Joan receives a phone call from one of her journalist friends. He calls to enquire whether there is any truth in the rumour that he has heard regarding the death of a patient due to a doctor's negligence. Torn between her instructions by management not to admit this to the media and her good reputation regarding truthfulness towards the



media, Joan has to make a decision that can have a major effect on her present and future career at the hospital, as well as her relations with the media. She can admit it 'off the record' and request the journalist not to publish the story in light of their long-standing friendship; she can disregard management's instructions and tell the truth; or she can follow management's instructions and deny it.

Before Joan can make her decision, the journalist, suspecting that she might try to cover up the story, invites her to join him and a group of friends for an all-expenses-paid weekend at Sun City in exchange for information regarding this case. He is aware that she has never been to Sun City as she once expressed a wish to go there. Once again, Joan is confronted with a very difficult choice.

Questions

1. If you were in Joan's shoes, how would you have acted:
 - a. towards management's request in the first place?
 - b. towards the journalist's very tempting exchange offer?
2. What decision would you have made? Support your answer by providing reasons.
3. Discuss all the ethical dilemmas involved in this scenario, from management's actions and the decisions Joan is facing to the offer from the journalist. Consider the various options, weighing the rights and wrongs against one another.
4. If the journalist was willing to accept the off-the-record information and kept to his undertaking not to publish the story, would you say his conduct was ethical? Support your answer by providing reasons.
5. In your opinion, is the offer of a free trip to Sun City in exchange for the information ethical? Support your answer by providing reasons.

Scenario 2

Paul Pieterse is the head of public relations for pet food manufacturer Purrfect Pet Foods. The company has recently experienced a crisis: testing showed that they had been putting sub-standard ingredients into their pet food products. The brand has had a lot of bad publicity as a result. Paul has decided to write positive client messages and post them on the website as authentic client messages in an attempt to deflect attention from the bad publicity.

Questions

1. Is what Paul has done an ethical public relations tactic?
2. What other ways could he rather have used to better the company image? Give examples.
3. Discuss the ethical dilemmas involved in doing what Paul has done.

Facing moral ethics

Both the public relations practitioner and the journalist must realise that ethical dilemmas raise tough questions about the right to privacy and the public's right to know. Both must have credibility and must be respected by the various publics with whom they interact.

When dealing with situations that are difficult to categorise as definitely right or wrong, remember that your ultimate decision should be made with respect, competence and an active, creative imagination to arrive at positive ethical solutions. Although you can always refer to the written code of professional standards to support your decision-making, you need to bear in mind that your decision may have implications that are not apparent from the written code. In accepting the code at face value, the needs and interests of the public always come first.

Public relations practitioners often have very difficult decisions to make as they not only have to consider their own behaviour, but also that of the institution that they represent. In the first scenario, should Joan choose the option to divulge the information to the media, she could not only jeopardise her chances of promotion but could also face dismissal. The hospital also has a good image and this negative incident could harm the image that Joan had worked so hard to help create. Despite the impact on the hospital's image, Joan should be focusing on what is more important: her possible dismissal and the hospital receiving negative publicity, or silence in exchange for possible promotion and the hospital upholding its good name. One would obviously prefer to choose the latter, but is it right in view of ethical standards?

The best option for Joan would be to tell the journalist that she would investigate his inquiry and then to approach management, informing them that this rumour had reached the news media. In an effort to uphold management and her own ethical standards she should persuade management to issue a media release to answer the inquiry, even though the doctor in question may face action and the hospital may receive negative publicity. The main ethical directive here is to tell the truth and to provide an accurate picture.

Moral ethics: our concern for good behaviour; an obligation to consider not only our own personal well-being but also that of society as a whole

The media deserves honest and valid use of the channels – you should not involve it in compromising situations through, for example, lying or feeding journalists insignificant or incomplete information. The public relations practitioner should respond to the media with a straightforward presentation of the facts, even when the story is unfavourable.

Another option Joan could have chosen was to admit the story to the journalist but to request him not to divulge his source of information. By taking this route, Joan would have put the journalist in a difficult position, since he would then be confronted with the ethical question of when and how he should acknowledge the public relations practitioner as a source of news. The journalist should, on his part, employ discretion and good editorial judgement about what is disseminated and whether attribution should be withheld.

There was one more option open to Joan: that of accepting the journalist's offer of a trip to Sun City in exchange for information. Clearly, this is something that Joan should not even consider. The code of ethics states that the public relations practitioner may not receive compensation from the news media for disseminating information, nor may he or she offer compensation to a journalist for ensuring publicity.

A public relations practitioner should realise that the news media could be helpful but also harmful. You should not act on what is expected of you, but rather be able to reflect on what is ethical.

In real life, it sometimes happens that the public relations practitioner wishes to thank the news media for publishing newsworthy events. Likewise, a journalist may wish to thank the practitioner for assistance in gathering news. In such cases, the exchange of small gifts is regarded as harmless and is perfectly acceptable. However, ethics will play a role where a gift to a public relations practitioner or to a journalist seems large enough to be potentially compromising.

In the second scenario above, by fabricating information Paul has put both himself and the organisation into an extremely difficult ethical position. He could be dismissed for this and create even more of an issue for the organisation. He has fabricated information in an online space – information that remains permanently in

cyberspace and is very difficult to erase if the situation is exposed. In this situation, the ideal would have been for Paul to find clients who had genuinely had positive experiences with the brand and use their testimonials. He could then have embarked on publicity-generating public relations activities attempting to improve the tarnished image of the organisation.

By posting positive messages about the organisation that are untrue, Paul is putting the company at major risk. If it is discovered that these client messages are not true, the consequences would be far worse than the negative publicity that has already been generated by the food being of a sub-standard quality. The organisation itself would be viewed as an organisation that cannot be trusted. Pet food is a product with which stakeholders would not gamble as many people's pets are part of their families.

Paul's first option is to continue pretending to the public that the messages are positive and use these messages to try to restore the company's corporate identity and image. While this may add a positive spin to the organisation, the risk of exposure will always remain. Online media platforms allow for this type of fictitious information because the organisation manages and controls the messages disseminated on the website; therefore, it is easy to commit such fraud.

Purrfect Pet Foods could have admitted its wrongdoing in the sub-standard food debacle and apologised to the public for this issue. Another similar option would be to admit wrongdoing and then explain the ways in which Purrfect Pet Foods intends to improve its quality and the measures it intends to take to ensure that this does not happen again.

From the above, it is clear how difficult ethical decisions can be. As a professional, however, you should always uphold the code of professional standards, even if it could jeopardise yourself and/or the institution you represent. As a public relations practitioner, you should always be aware of ethical pitfalls. If you are not sure how to act in certain situations or of what the consequences of your actions might be, consult your professional body for assistance instead of getting yourself knee-deep in trouble.

It is also true, however, that what is ethical to one person is not necessarily ethical to another. The practice of ethics is interpreted not only from a personal viewpoint, but also from a cultural one. You may, therefore, sometimes find yourself making questionable decisions in response to the moral choices with which you are faced.



Exercise

Earlier in this chapter you were asked to answer questions based on scenarios. Go back to those answers and see if you still agree with your responses or if, after having studied this chapter, you would change any of them. Compare your answers with those of a friend and try to establish whether you have an understanding of what moral ethics involves.

Legal ethics and the public relations practitioner

Just as public relations practitioners have to know what is ethical in the normal carrying out of their duties, it is also essential for them to understand that there are legal ethics to which they also need to adhere.

There are numerous legal issues that public relations practitioners may face in their daily work. An awareness of these is essential in order to prevent any harmful legal matters arising against them or the organisation they represent. They should therefore always act within the prescribed legal ethics. If, at any time, they have any doubts regarding the legality of an action, they should first consult the organisation's legal department for clarity and guidance.

Public relations practitioners must be careful not to write or say anything that may harm the reputation of another person. Even when an individual is a public figure, public relations practitioners must always consider the individual's right to privacy. Among the legal pitfalls of which they must be aware are defamation of character and the misuse of copyright materials.



Exercise

Let us look at another scenario that a public relations practitioner could face working for any company, whatever its size.

Miriam is the public relations practitioner for a reputable medical company. This company has pioneered the manufacture of medicine for several life-threatening illnesses and, through Miriam's endeavours, is riding the crest of the wave. Its squeaky-clean image has, up until now, never been tarnished. Then some shocking facts come to light.

One of the company's top researchers is caught selling harmful drugs. The police uncover a manufacturing plant in the company's basement where the researcher makes his potentially lethal pills, which he is allegedly selling to teenagers at raves.

The media headlines are shocking. All the newspapers carry the story of the researcher, the basement and the drugs.

The newspaper articles hint that the company is involved and that the staff has received a percentage of the sales. The researcher soon appears in court and pleads not guilty to several charges against him. He also implicates one of the staff members, Miriam's friend, in the scandal, saying that this person has helped him to produce and sell the drugs. The friend also appears in court.

What must Miriam do to save the company and help her friend who, she is certain, must be innocent? The directors of the company have instructed her to salvage the situation. Should Miriam keep quiet and issue no statements on behalf of the company and hope the nightmare will simply go away? Should she issue a statement in which she puts all the blame on the researcher and maintains that her friend is innocent? Should she try to deny police reports about the company's involvement? Should she explain to the media that the researcher has an extravagant lifestyle with a house, a luxury yacht and many overseas trips while her friend, who is supporting her sick mother and three brothers and sisters, is living a hand-to-mouth existence?

Questions

1. If Miriam keeps quiet and issues no statements, what do you think will happen?
2. Should Miriam issue a statement saying that the company was unaware of what was going on and put the blame solely on the researcher? Support your answer by providing reasons.
3. Should Miriam issue a statement claiming that the whole incident has been blown out of proportion by the police and the media?
4. Should Miriam issue a statement explaining how the researcher probably sold drugs to maintain his extravagant lifestyle while her friend possibly helped him because of her much needier conditions at home?

As a professional public relations practitioner, Miriam's first concern in dealing with this case has to be for the company for which she works. She has an obligation to try to protect her company's image and, in this case, it involves trying to repair the damage caused by the media, the police investigation and the court case.

Miriam must also bear in mind certain legal ethics. Firstly, if she tries to downplay the scenario, she could be undermining the police investigation. For example, if the police claim that drugs valued at hundreds of thousands of rand had been manufactured, while Miriam claims that they were of little value, who do you think the media will be likely to believe? In addition, Miriam, as well as the company she represents, will lose their credibility in the eyes of both the media and the public should the court case reveal that the police allegations have been correct, regardless of all the pioneering work that Miriam's company has done.

Issuing a media release blaming the researcher and proclaiming her friend's innocence is not a good course of action. Firstly, everyone, no matter who they are or what position they hold, is innocent until proven guilty. Secondly, Miriam's opinion regarding her friend's innocence is based on her personal involvement and is not objective. Besides, it is the court's task to judge who is innocent and who is guilty.

Miriam should always remember that, once a person has appeared in court, the matter becomes *sub judice*, which means that no further statements about the case or about the people involved in the case can legally be made. In other words, should Miriam issue a statement describing the vastly different lives of the two accused, she would be acting contrary to the law. Miriam's best choice would be to be open with the press, to explain that the company was horrified by the police investigation and that it is giving the police its full co-operation. She could also mention that structures have been put in place to prevent a similar occurrence from happening in the future and that an internal investigation is underway at the company (if either of these statements are true). She should explain that she is not at liberty to say more about the case as the matter is now *sub judice* and should express her confidence in the process of the law.

Once the court has reached a verdict, she could issue a further statement expressing gratitude that the whole matter has now been dealt with. She should, under no circumstances, become involved with issuing statements about the private life of either of the accused or find excuses for any untoward behaviour.

Summary

Legal ethics is much the same as moral ethics. In a case such as the one described here, the professional public relations practitioner must remain objective about the issues involved and must not pre-empt a court decision by giving out any information, no matter how trivial, while the hearing is in progress.

It is your duty, as public relations practitioner, to ensure that any statements you issue in such an instance are legally and ethically correct. In doing so, you and the company you work for remain credible. If you overstep the mark, you lose all credibility.

Moral ethics, however, must not be considered to be irrelevant. In the course of a public relations practitioner's duties, the upholding of moral ethics is as important as the upholding of legal ethics. One small mistake on the part of public relations practitioners can lead to numerous unforeseen problems that may even put their careers in jeopardy. During your career you may be faced with many opportunities that may, at first, seem exciting and to your benefit. Beware, however, that failure on your part to uphold the Code of Professional Standards for the Practice of Public Relations may have disastrous consequences. If you find yourself in a tricky situation and you are in doubt about any aspects of the code of conduct, consult a colleague or a professional. Never take a chance and think you will get away with it – you will be caught eventually.

You should also keep in mind never to overlook the professional impact of your digital footprint – it is imperative for positive professional online reputation management. The Internet has increasingly become a network for both personal and professional interactions, creating a digital footprint for almost every user. What you say and how you say it online must be bound by moral and legal ethics.



Test yourself

1. Explain the meaning of the terms moral ethics and legal ethics, and give a practical example of each to support your answer. (Provide your own examples – do not follow the examples given in this chapter.)
2. If you invite a journalist to lunch to strengthen professional relations, would you be acting against moral ethics? Support your answer by providing reasons.
3. In preparing your internal newsletter you come across an interesting article published in a magazine that you feel would be appropriate to publish in your newsletter. You copy this article word for word and neglect to give credit to the original magazine. Soon after your newsletter is published, the magazine takes legal action against both you, as editor, and the organisation. Explain the reason for this legal matter. What could you have done to prevent this?
4. You have been working as public relations practitioner at your organisation for five years, gaining much experience and receiving many accolades for a job well done. The senior public relations practitioner resigned and you were of the opinion that you would be promoted to her post. However, management announces that your colleague on the same level as you will take over as senior public relations practitioner. That evening, you post derogatory remarks on your personal Facebook and Twitter accounts about management's bad decision and against your colleague – badmouthing them for the unfair treatment you received and for their oversight to promote you to the post as you felt you were a much better worker than your colleague. On your Facebook profile it says where you work. Do you think you acted ethically with your online remarks about management and your colleague? If management decides to dismiss you for bad management of your digital footprint, would that be within their right in view of moral and legal ethics?

SENDING YOUR MESSAGE THROUGH THE MEDIA

One of the public relations practitioner's most important tasks is dealing with the media. When sending a message to the external stakeholders, public relations practitioners have to consider various media channels, depending on which ones will be best suited for the particular message. The channels that will ensure the best publicity are the mass media because they have the greatest reach.

Clever decisions on the part of the public relations practitioner could ultimately result in media coverage of a newsworthy incident, whereas the wrong approach could result in failure. Handling the media unprofessionally could result in negative publicity, which could cause an organisation immense harm. The power of the media should never be underestimated.

Understanding the media will not only result in effective and purposeful liaison between public relations practitioners and journalists – it will also enable public relations practitioners to decide when and for which media medium and outlet their message will be suitable. It further enables them to provide the type of effective information needed by each medium.

Dealing with the media is an ongoing process and regular contact with members of the different media should be maintained.

In this interactive relationship and in dealing with the various stakeholders, it is important that journalists and public relations practitioners uphold certain ethical and social standards. The integrity of members of these two professions should never be in doubt. This would erode the trust of society and cause great damage to the image of both professions.

Introduction to the print media – newspapers and magazines



Objectives

After you have studied this chapter, you should be able to:

- describe what is meant by the print media
- describe the nature of the print media
- determine the advantages and disadvantages of the print media
- explain the importance of the readership and circulation of print media.

Introduction

Although the print and electronic media have the same aim – namely to inform, entertain and educate – they look different and operate differently. Public relations practitioners should keep this important fact in mind when dealing with the media and should understand that certain obstacles may hamper or facilitate the end product generated by a specific medium.

In this chapter, we look at several general aspects of the print media. Although some may sound obvious, they can have an important influence on how public relations practitioners prepare and present their messages, as well as the way in which they deal with contact people in the different media.

The nature of the print media

In its broadest sense, the print media can be described as anything that is printed and distributed to the public. The print media comprise various publications, leaflets and pamphlets that can all at some time be put to good use by public relations practitioners for a specific purpose.

When dealing with the print media, there are certain important aspects to bear in mind. These include the following:

- ▶ Different publications need information for different reasons (a daily newspaper mainly needs hard, factual news, whereas a specialised magazine such as *Getaway* needs information only on a specific subject – travel, in this case).
- ▶ Different publications have different target markets and public relations practitioners should acquaint themselves with these markets (the newspaper *Business Day* focuses on businesspeople in general whereas a magazine such as *Fair Lady* focuses on women of a certain age and demographic). Readers (a publication's target market) determine, to a large extent, the publication's content – they might also be the reason why an editor or subeditor will consider the public relations practitioner's story suitable.
- ▶ Publications work to deadlines – therefore, it is of no use sending information to a monthly magazine about something that will not be relevant at the time of publication. Rather adapt the article by removing pieces imposing time limits.
- ▶ Each publication has its own identity, created by using specific typefaces and fonts, colours, photographs and layout.
- ▶ Top-quality photographs and graphics can add tremendously to a publication's appeal, but each publication has certain preferences in this regard. It is advisable to include people in photographs (where possible) and to 'tell a story' through creative photography.
- ▶ Very few publications will use a media release in its original form. If one is used, it is rewritten according to the publication's style and to what the subeditor or journalist considers newsworthy. A publication may sometimes not be interested in a media release, but they may find something else in it – a sentence or statement, for example – worth following up. This does not mean they will definitely publish

something, but it is possible that a completely different aspect, something you did not consider newsworthy, is covered.

Advantages and disadvantages of the print media

One of the most important characteristics of print media is that the reader must be literate and have the time and desire to read. Unlike the electronic media, which can be regulated by merely pushing a button, people who want to read have to put more effort into obtaining the publication, ie they have to buy or borrow it.

Once a publication has been obtained, the reader's attention is retained by eye-catching headlines, different fonts, typefaces, etc. Most importantly, the content must hold the reader's interest.

Print media are not restricted by time slots (as with electronic media). Publications can be read anywhere at any time. Print media also have a longer lifespan than information transmitted through the electronic media.

Some differences between newspapers and magazines

When dealing with the different media, it is important that the public relations practitioner selects the right information and photographic material for different publications. The following aspects should be kept in mind:

- ▶ Newspapers need accurate, factual information and photographs about newsworthy events immediately after the event has occurred. Photographs with news value are important. This is not the case with magazines, which have more time to work on a story. Magazines need high-quality photographs (they have the time to wait for them) and more background information in each article.
- ▶ A magazine article need not have the news characteristics required by newspapers. Magazines use interesting, unique, human interest, educational or entertaining information for their articles.



Take note

Different publications publish different types of stories – and use different styles. Newspapers publish mainly:

- hard news stories that are concise and written according to the inverted pyramid style (Who, What, When, Where, Why, How – also known as the 5Ws + 1H); and
- features, which are more detailed than hard news stories.

Magazines, on the other hand, do not publish short, newspaper style stories, but use features, eg profiles, human interest features, light stories, etc.

Inverted pyramid:

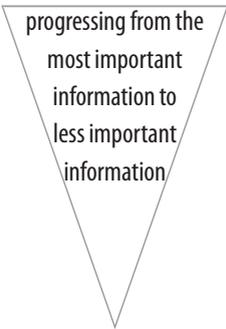

progressing from the most important information to less important information

The type of paper used by a publication will influence the end result. Photographs reproduced in a newspaper will not be of the same quality as those used in upmarket magazines because magazines are usually printed on better-quality paper.

Newspapers normally appear on a daily or weekly basis, whereas magazines mostly appear weekly, fortnightly or monthly. The public relations practitioner must keep this in mind and provide the right information at the right time. News for newspapers must be fresh, factual and of current value, whereas the same incident may be covered in more detail as an in-depth feature article in a magazine a few months later.

Deadlines for newspapers must be kept daily (or weekly in the case of weekly newspapers), whereas deadlines for magazines can be set up to two months before the magazine is distributed.



Exercise

Considering the differences between newspapers and magazines, compare a magazine to a daily newspaper with special reference to the differences in format, layout, fonts, quality of paper, types of article, etc. List the different articles appearing in each publication.

The print media in South Africa

Several large publishing groups in South Africa are responsible for most South African publications. They publish a number of urban, daily and weekly newspapers countrywide. The newspaper industry is dominated by four main players: Media24,

Independent Newspapers, the Times Media Group and Caxton CTP. In addition to these groups, there are smaller companies and individuals who publish newspapers and magazines.

This section has online support material available.

Major newspapers and magazines are linked to the Internet through the website news24.com, which provides news 24 hours a day, seven days a week, covering news, sports, business, etc.



Exercise

Determine which publications belong to which publishing group. This information can be found in every print medium. List the different publishing groups and the publications for which they are responsible.

Readership and circulation

Readership refers to the number of people who read newspapers and magazines (Jefkins 1992: 51). Circulation figures indicate the average sales of each publication. When the circulation figure of a publication is compared with its readership, it will be found that the readership is higher than the circulation figure. Why? Let us look at the following example:



Example

You buy a *YOU* magazine. You take it home and read it. Your spouse and three children also read the magazine. What has happened? One copy that was bought was read by five people! Therefore, the readership is higher than the circulation figure.



Take note

It is important that the public relations practitioner knows where to find information on what is published in which areas, and which publication(s) are suitable for different purposes.

The estimated readership of publications, ie how many people read the publication once bought, the areas in which they are circulated and the number of copies normally sold are good guidelines. The Audit Bureau for Circulation (ABC) (www.abc.org.za) and the All Media Product Surveys (AMPS) publish this kind of information.

Putting the media to work

Most public relations practitioners know that a basic knowledge of the print media is merely a starting point. Personal and continuous contact with influential members of the media should be considered essential to a successful media relationship.

All public relations practitioners should have a list of publications that can be used, together with contact names and telephone, cellphone and fax numbers, as well as e-mail addresses. To make life easier, important points such as the type of information needed and the details of published articles relevant to the organisation should also be listed.

Summary

A basic knowledge of the print media will help the public relations practitioner to eliminate unnecessary work when preparing information for possible publication. It will also guide the public relations practitioner in compiling different articles for different purposes in different publications.

The next two chapters deal with newspapers and magazines in more detail.



Test yourself

1. List the most important differences between newspapers and magazines.
2. With reference to the nature of print media, discuss important aspects that public relations practitioners should bear in mind when they want to use print media to convey their message.

Print media – newspapers



Objectives

After you have studied this chapter, you should be able to:

- discuss the physical appearance and style of newspapers
- distinguish between different types of newspaper and illustrate how differences can be exploited by public relations practitioners
- discuss the functions, content and target markets of newspapers
- describe the structure of the editorial staff and their functions
- identify the appropriate editorial staff members to contact with newsworthy information
- discuss how a newspaper journalist operates.

Introduction

The newspaper is one of the most important media through which public relations practitioners can send their messages to external stakeholders. It is, however, important to remember that the newsworthiness and nature of a news story will, to a large extent, determine its suitability for a specific newspaper. A newspaper's main aim is to give its readers the latest news and this determines what is published.

Although electronic media such as radio and television, and digital media such as the Internet and social media, have eroded the power of the press, the printed newspaper has proved its importance as a conveyor of information. Many newspapers today also have online versions. Newspaper circulation has been affected by the advent of online technology.

To survive strong competition, the press has changed its image and goals over the years. It can now be considered the medium best able to supplement news broken by the electronic media by carrying additional background information. Newspapers now rely more on entertaining and educating their readers than they did in the past.

Although the press has an interesting history, we will not go into it here, but will focus on the importance of newspapers to the public relations practitioner. For this purpose, we need to know how newspapers are structured, how they operate and what they regard as important when gathering and writing news for their readers. We will look at local and national newspapers in South Africa to provide a basis from which new and prospective public relations practitioners, armed with knowledge of how the media operate, can establish good relationships with media people.

Types of newspapers

Newspapers are a part of everyday life. They are sold on street corners and in shops, they are subscribed to or they are delivered free of charge to our homes as community newspapers. Posters with headlines are used to advertise a newspaper's main news of the day.

In addition to newspapers that are sold, there is a vast range of other, free newspapers. These newspapers are aimed mainly at local communities and, apart from their strong advertising complement, they contain important and interesting local community news.

Not all newspapers are available everywhere – some are confined to certain areas, and their names are often an indication of their distribution area. Think, for instance, of the *East Rand Herald* or the *Kagiso/Dobsonville Express*.

Newspapers are classified according to different criteria. These are:

- ▶ area of distribution
- ▶ frequency of distribution
- ▶ whether they are paid for or free.



Take note

As a public relations practitioner, you need to make a list of newspapers that will be of use in your specific area.

The All Media Product Surveys (AMPS) noted the following in 2013 (SouthAfrica.info 2013):

- ▶ Most of the newspapers published in South Africa are English-language newspapers.
- ▶ There are 22 large urban daily newspapers and 35 similar weekly newspapers, as well as about 400 regional and community newspapers in South Africa. These regional and community newspapers are mostly free.
- ▶ In addition, South Africa has many high-quality news websites, both general and specialised.
- ▶ Readership of urban daily newspapers is about 10.5 million. Half of South Africa's population who are older than 15 (about 17.5 million people) read newspapers in South Africa.
- ▶ Apart from international newspapers, which are available in our bookstores, we find a number of South African daily newspapers such as the *Daily Sun*, *The Star*, *Sowetan*, *Beeld*, etc and weekly newspapers such as the *Sunday Times* and *Rapport*.

This section has online support material available.

National newspapers

National newspapers are distributed countrywide. They include daily newspapers such as *The Star* and the *Sowetan*, and weekly newspapers such as the *Sunday Times* and *Rapport*. National newspapers cover national and international issues, politics, crime and violence, economics, human interest stories, sport, etc. Coverage includes news of national interest, eg an increase in the petrol price, international investment in South Africa, a baby abducted from a hospital, etc.

Some national daily newspapers allocate space for local news in certain areas on specific days of the week. News of various kinds will be suitable for supplements.

Regional newspapers

Regional newspapers are similar to national newspapers, but they are distributed in certain regions only. These newspapers carry a variety of news reports and articles and are excellent

media for the public relations practitioner. Regional newspapers include *Die Burger*, *Beeld*, *Cape Argus* and *City Press*.

Local community newspapers

Local community newspapers are usually published in tabloid format and their names usually indicate the community or area they serve, such as *Bloemnuus*, *The Roodepoort Record* and *Krugersdorp News*. These papers are very popular with their readers. Most of them are delivered weekly and free of charge to all households in certain areas (hence the name 'knock-and-drop').

There are more than 400 local newspapers countrywide, of which a vast number belong to the Caxton group. Some of these newspapers cover a much wider area than local communities, towns or cities, especially in certain farming and more remote districts. Examples of these newspapers include *The Lowvelder*, the *District Mail* and the *Potchefstroom Herald*.

The cost of producing most community newspapers is largely covered by advertising aimed at the local market. Although advertisements might take up as much as 70 per cent of available space, community newspapers remain popular with the markets they serve, as the available editorial space focuses on local interest stories such as happenings at local schools, churches, organisations, communities, sports clubs, etc.

Community newspapers focus on the local community, concentrating on human interest stories with few hard news reports. Although the standard and coverage of the community newspaper cannot be compared with the daily newspaper, it plays a definite and important role for the public relations practitioner. These newspapers can often be used for articles that do not have a strong news angle, or that are only of interest to a certain community. Another factor favouring community newspapers is that they often give organisations editorial coverage when they buy advertising space. This gives the public relations practitioner an opportunity for further publicity that should be exploited.

It is important that the public relations practitioner has a fair knowledge of circulation and readership figures, as this will help to ensure that the target market is reached through the relevant newspapers.



Exercise

Identify and list the various newspapers in your area that you can approach with newsworthy information.

The appearance and style of newspapers

Physical appearance

A newspaper is a relatively cheap publication containing the latest news and information about topical issues.

Newspapers differ in physical appearance. The two most popular sizes are the broadsheet (A2 size), such as *The Star*, *Business Day* and the *Sunday Times*, and the tabloid (pony) format (A3 size), such as the *Sowetan*, the *Citizen* and most local and community newspapers.

The quality of paper on which newspapers are printed is of a relatively low grade as newspapers are not normally kept or archived. They have a shorter lifespan than a magazine, for example. News is gathered and published on a daily (or weekly) basis. Some daily newspapers have more than one edition. The edition is indicated on the front page by words such as 'late edition' or 'final edition'. The latest edition will have updates or fresh information about major stories.

Newspapers vary in volume and thickness. The space taken by advertisements often determines the newspaper's page count and space available for editorial matter. Advertising space is sold and takes up prominent positions on a page.

Style

Newspapers differ from one another because they are written, compiled and laid out according to their own style.



Take note

Style is a set of conventions governing the writing, language, punctuation and layout applied by staff members to a specific newspaper.

Visual layout

Each newspaper strives towards a distinct appearance. Some newspapers prefer a sensational layout with large news photographs, big, bold headlines and contrasting colours and sizes, whereas others may use a more conservative layout. Compare, for instance, a front page of the *Sunday Times* with one of *Business Day*.

Balance, contrast, proportion and unity are important concepts to bear in mind when layout is done. These concepts are discussed in Chapter 17.

Legibility

The legibility of newspapers is important. Readers often spend limited time reading newspapers and they want to expend as little energy as possible in doing so. For this reason, newspapers use legible typefaces, short sentences and short reports. The language of any newspaper is simple and is aimed at as many readers as possible. Newspapers are written for a wide readership, from those with a Grade 9 (or equivalent) reading knowledge up to highly qualified readers.



Exercise

Take any two newspapers – for example, the *Sowetan* and *The Star* – and compare their physical appearance, their style, their visual layout and their legibility.

	Sowetan	The Star
Physical appearance		
Style		
Visual layout		
Legibility		

Functions, target market and content

Functions

Newspapers play a very important role in our everyday lives and have distinct functions. Newspapers not only *inform* us of the latest news; they also *educate* and *entertain*. These functions are clearly illustrated by the hard news on the front page, the

information on the entertainment pages and the educational supplements.

Target market

Some newspapers are aimed at specific markets. *Business Day*, for example, is aimed at business and financial people. Other newspapers use supplements to cater for specific needs. A weekend supplement will appear before the weekend or a ‘women’s focus’ supplement might be included on a certain day of the week.

Content

The content of a newspaper consists of more than news reports and features. Newspapers include regular columns, letters, cartoons, etc, which all play an important role in defining each paper’s make-up.

Newspapers provide what their readers want. Figures 6.1a and 6.1b provide an interesting and useful picture illustrating how the standard content of a national newspaper may differ from that of a local community newspaper. This is merely an illustration, and newspapers might deviate from this norm. Local newspapers sometimes carry fewer *advertorials*. These differences indicate which newspapers could be used to publicise events.

Advertorial: editorial copy highlighting a product advertised on the same page

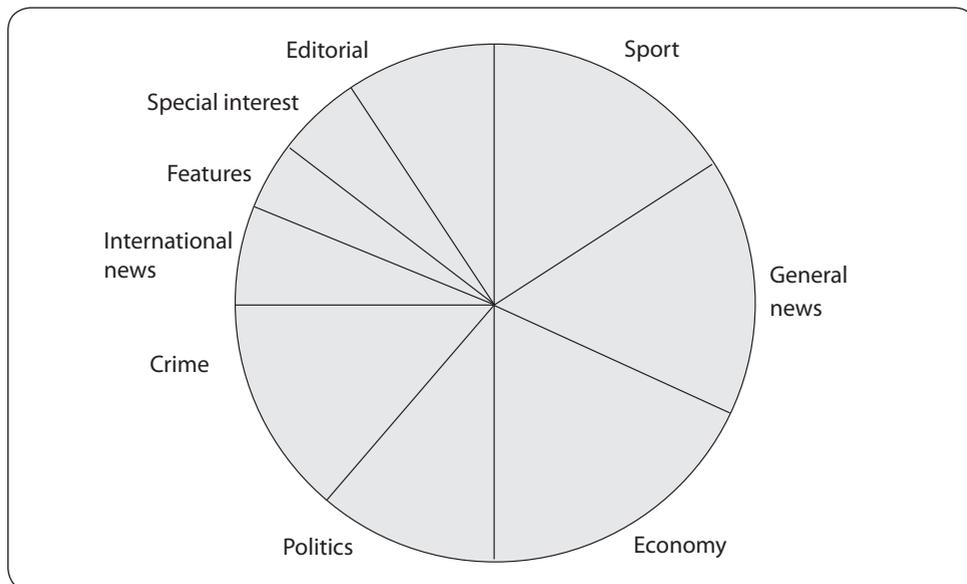

Figure 6.1a Content covered in a national newspaper

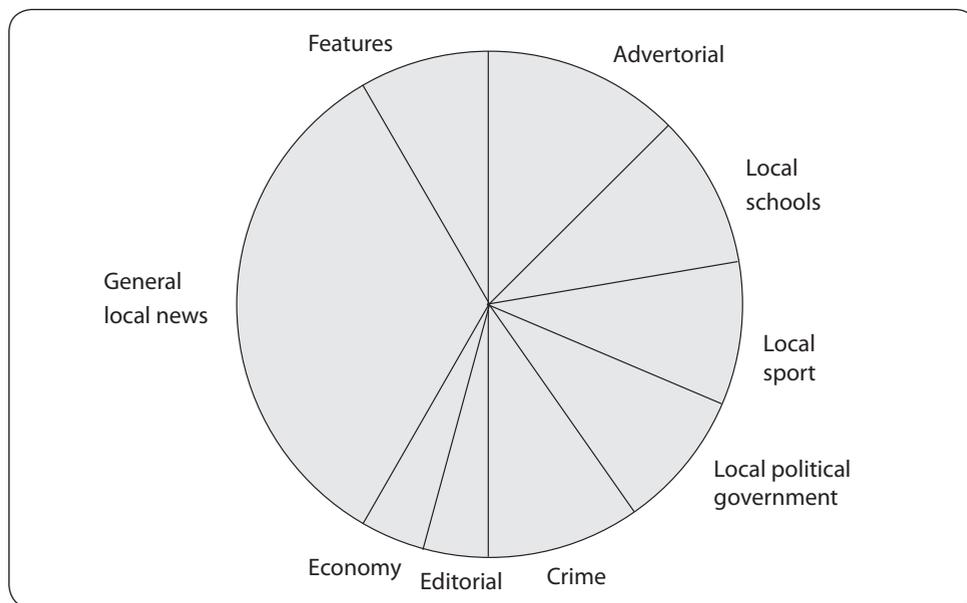

Figure 6.1b Content covered in local community newspapers

The content of a newspaper is normally organised or structured according to a standard layout. This means that certain types of news or articles are allocated to certain pages in a newspaper (such as sport on the back page) or even to certain columns (eg the editor's column on the upper left-hand side of the editorial or leader page). The structure of each newspaper is also influenced by the newspaper's style and the image it wants to create.

The following are some of the standard pages found in a newspaper. (There may be more examples and their content may differ from these examples.)

Masthead: the area in which a newspaper's name appears in big, bold letters on the front page

Teasers: focus on important or interesting stories inside the newspaper

Front page and other important news pages

The front page carries the most important news stories (headline news). A newspaper's name always appears in big, bold letters on the front page in an area called the *masthead*. The front page 'sells' the newspaper and does not only have to be visually attractive but must also 'invite' the reader to buy the newspaper – by indicating what can be read inside. Apart from bold headlines for lead stories, *teasers* are often used on a front page to indicate which stories can be read inside. (See more on the anatomy of the front page on page 80.)

The front page does not normally contain more than four or five news reports (usually hard news and one or two photographs). Other important news reports will be printed on pages 3 and 5 (odd right-hand pages), which are also considered important news pages. Any hard news on a company has a fairly good chance of appearing on these pages. Public relations practitioners must therefore always be prepared for and informed of any news event in their own organisation before speaking to the press. Unfortunately, it may often be negative news (a disaster, an emergency, crime, etc) that appears on these pages.

Editorial page

This page is usually an even-numbered page (page 2, 4, 6, etc) and has a standard layout. The *editorial or leader page* is normally used for editorial and other comment. Newspapers strive to publish fair and objective news reports. The editorial page is used to comment on issues and/or news stories and reflects the opinion of the newspaper. In addition to the editor's comments, the rest of the page is used for other regular columns.

Editorial or leader page:
page containing articles written by or on behalf of an editor, giving opinions on topical issues

Women's page

The women's page, which is an important part of certain newspapers, provides for women's interests and needs and also ensures that women read newspapers. The type of information found on this page will include a variety of articles dedicated to the career woman, health care, child care and education, beauty, house and home, cooking, fashion, etc.

Financial page

Some newspapers have a large financial section that is not confined to one page, comprising a supplement (eg *Business Times*, a section of the *Sunday Times*). Although hard financial news stories will appear on one of the news pages, there are many other financial news stories that are considered to be important to readers. Financial news will include stock exchange news, bullion prices, political uncertainties, wars, financial investments, labour, economic developments, etc. Certain events, for example the annual budget, can provide good financial stories that cannot all be adequately covered on the front page.

Entertainment or social page

The entertainment page gives information about the latest entertainment at theatres, cinemas, on television, etc. Reviews of popular restaurants might also feature on this page. The entertainment section can also be a supplement, especially at the end of the week, to publish information about entertainment taking place during the weekend.

Sports page

South Africans are known for their interest in sport and there is enough sporting news to fill more than a page each day. Important sports stories, however, might be carried on the front pages – think of the many World Cup tournaments and international games in which South African sportspeople compete.

Anatomy of the front page

Reading a newspaper is easy if you know its different parts and what each contains, such as news, articles of opinion, features and advertisements. The front page of a newspaper needs to grab the most attention because readers are able to see the bold headline and any pictures that may affect the purchasing decision. It has a specific layout in terms of graphics, text and positioning. So, what are the parts of the front page of a newspaper?

Some or all of these may be found on the front pages of newspapers:

- ▶ **Banner headline** – a headline that spans the full width of the page
- ▶ **Block** – a picture
- ▶ **Box-out** – a small part of the page, sometimes shaded in a different colour, to draw the reader's attention
- ▶ **By-line** – the name of the reporter, which is often included at the beginning of the feature rather than at the end, or not at all
- ▶ **Caption** – typed text under photographs explaining the image
- ▶ **Credits** – mention of the author of a feature in the form of a by-line. Photographs may have the name of photographer or the agency that supplied them alongside them and reports may include the name of the news agency that sent them (eg SAPA, AP, Reuters)

- ▶ **Crosshead** – a subheading that appears in the body of the text and is centred above the column of text (if placed on to one side, it is called a **side-head**)
 - ▶ **Cross-reference** – tells readers the headline of an article on another page that is connected with the story they have just read
 - ▶ **Dateline** – the place from where the report comes
 - ▶ **Ear** – an advertisement at the side of the masthead
 - ▶ **Edition logo** – used if a daily newspaper has several issues of the newspaper in print in one day; for example, the edition line identifies whether the newspaper publication is early, late, late final, etc
 - ▶ **Exclusive** – coverage of a story by the newspaper and no one else, which may sometimes be paid for by the newspaper (eg a celebrity wedding)
 - ▶ **Headline** – the main statement, usually in the largest and boldest font, describing the main story
 - ▶ **Kicker** – a story designed to stand out from the rest of the page by the use of a different font (typeface) and layout
 - ▶ **Lead story** – the main story on the front page, usually a splash
 - ▶ **Lure/teaser** – a word or phrase directing the reader to look inside the paper at a particular story or feature
 - ▶ **Masthead** – the title block or logo at the top of the front page identifying the newspaper, often set into a block of black, red or blue print or boxed with a border, plus the place of publication and date and sometimes containing an emblem or a motto
 - ▶ **Menu** – the list of contents inside the paper
 - ▶ **Nib** – stands for news-in-brief (a very short article)
 - ▶ **Pugs** – the ‘ears’ of the page at the top left- and right-hand corners of the paper, showing the price of the paper, the logo or a promotion, which are well placed to catch the reader’s eye
 - ▶ **Reverse blocks** – words in white on a dark background to stand out against the usual black-on-white headline
 - ▶ **Rule** – a heavy line
 - ▶ **Secondary lead** – usually only a picture and headline, which gives a sneak preview of a story that may be found inside the paper
 - ▶ **Sidebar** – when a main feature has an additional box or tinted panel alongside it
 - ▶ **Solus** – a solitary advertisement
-

- ▶ **Splash** – the main story on the front of the paper, with the largest headline and a photograph
- ▶ **Spread** – a story that covers more than one page
- ▶ **Standfirst/lead paragraph** – an introductory paragraph before the start of the feature, sometimes in bold
- ▶ **Strapline/subhead** – an introductory headline below the headline
- ▶ **Tag** – a word or phrase used to engage a reader’s interest in a story by categorising it, eg ‘Exclusive’ or ‘Sensational’.

Let us study the front page below and identify some of its parts:

1. Ear/pug
2. Banner headline
3. Subhead/strapline
4. Solus
5. Masthead
6. Block

How many other parts can you identify?





Take note

Although this section on content focuses on newspapers, a similar layout can be adopted for in-house publications.



Exercise

Using the classification of newspapers' contents as a guideline, discuss how you, as a public relations practitioner, can apply a similar classification system to your in-house magazine.

Structure of editorial department and staff duties

Although newspapers differ as far as organisational structure is concerned, there are certain positions and duties that will always be peculiar to the press. A newspaper cannot function efficiently without an editorial department, an advertising department and a printing department. Let us look at the structure of the editorial department to get an idea of who is responsible for what at a newspaper. This will also give the public relations practitioner an idea of important contact people at the newspaper.

We look first at the standard editorial structure of a daily national newspaper and then at a local, community newspaper. The duties and responsibilities of each staff member are listed in brackets below their positions.



Exercise

Discuss the functions of the various editorial staff members of:

- a daily newspaper
- a community newspaper.

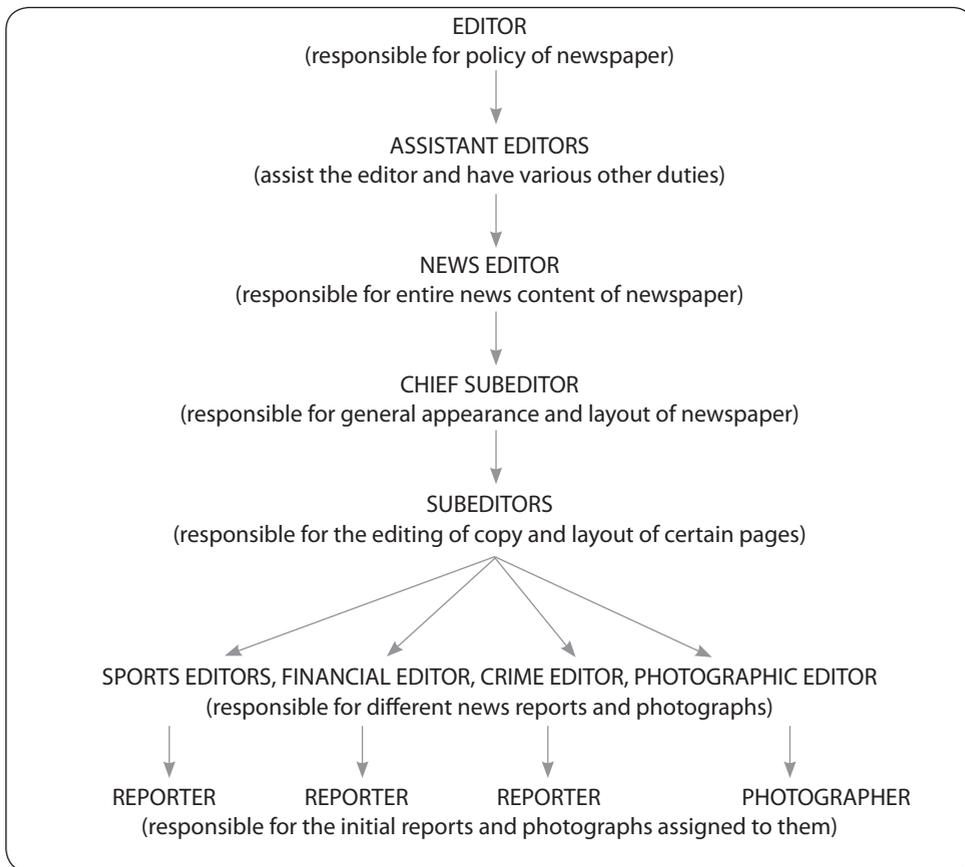

Figure 6.2 Editorial structure (daily national newspaper)

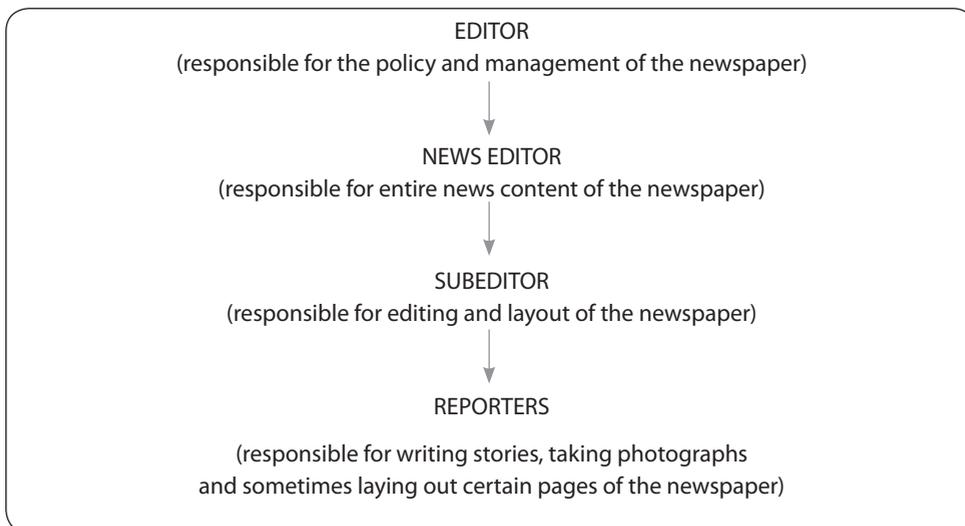

Figure 6.3 Editorial structure (community newspaper)

Contacting the newspaper

It is important that the public relations practitioner knows whom to contact at the newspaper. Initial contact should always be made through the news editor, whose secretary will forward any information if he or she is not available. A reporter who covers a specific field (beat) will be assigned to the story. In many cases, this reporter will be the person a public relations practitioner will contact most often. A public relations practitioner at a financial bank will usually contact the financial reporters of different newspapers, whereas the public relations practitioner of a regional police station will have contact with the crime reporters of different newspapers in the area.

The editor of a daily newspaper normally has little contact with the public and is not the person the public relations practitioner should contact with a news story. This is, however, not necessarily the case with a local newspaper where the editor is often well known to the community.



Exercise

Using your own organisation as reference, discuss whom you will contact at a specific daily newspaper and at a local community newspaper when you want to convey newsworthy information to the public.

How a newspaper operates

News follows a certain route from the moment it is identified to when it is sold as part of the newspaper on the street corner.

In Chapter 3 we discussed how news is identified. Let us look now at the rest of the process.

News stories are normally assigned to specific journalists by the news editor during a meeting. Journalists can also submit ideas of stories that they consider viable and may be instructed to write them. Once journalists have received their tasks for the day or week, they have to use every available source to gather as much information as possible for their news stories. They might have to work on more than one story at a time, and some will be more urgent than others. They might also be expected to take

their own photographs or may have a photographer assigned to them. Once journalists have enough information, they will type it on a computer according to a standard format. The news editor normally tells reporters what is expected of them.

Deadline: the time by which copy should be submitted to the subeditor

Press deadline: the time at which a newspaper is handed to presses for printing

Reports must be completed to fit in with the newspaper's *deadline* and *press deadline*. Newspaper reports are normally written according to a structure in which the 'Who, What, When, Where, Why and How' questions are answered according to the inverted pyramid structure. This means that the report will start with the most important facts and end with the least important or additional facts. Paragraphs should be short and the first one should not exceed 26 words.

Figure 6.4 Example of a news report

Hard copy: news report printed on paper

This report is edited by the subeditor – usually on a computer or on the typed copy. If the subeditor edits on *hard copy*, he or she uses standard editing symbols. These are discussed in more detail in Chapter 17.

Once stories have been checked by the subeditor, they are either sent back to the journalist to confirm or add facts or they are kept on the subeditor's desk for layout. Depending on the size of the newspaper, different categories of news stories are

allocated to different pages and the reports are passed to the relevant subeditors for layout.

The stories used in each edition and the space afforded them depend on the stories' news value and the availability of space.

Stories are chosen for their newsworthiness. When the pages have been set and everybody concerned is satisfied with the results, the newspaper is sent to the printing presses and then to the distributors.

At larger newspapers, the report goes through an even finer sifting process. The report firstly goes to the news editor on duty (ie night news editor), then to the editor on duty (ie night editor) who checks the facts and style before sending it to a subeditor to check the language and do the layout.

Summary

It is important to remember that, while this discussion gives detailed information about newspapers, public relations practitioners should know this information because they must:

- ▶ know who to contact at different newspapers
- ▶ be able to use certain journalistic skills in their everyday work.

Test yourself

1. Discuss how newspapers differ from one another in their appearance, style and legibility.
2. Discuss the different types of newspaper.
3. What are the main functions of newspapers?
4. Discuss how newspapers organise their content and give a detailed description of the front page's content.
5. Discuss why it is important for the public relations practitioner to have a knowledge of the structure and functions of the editorial department and staff at newspapers.
6. Discuss the process that a news story follows from the moment it is assigned to a specific journalist.
7. Study the front page of any newspaper and identify as many parts as you can. Provide labels for each part identified.

Print media – magazines



Objectives

After you have studied this chapter, you should be able to:

- differentiate between categories of magazines
- describe the editorial structure of a magazine and the functions of each staff member.

Introduction

Public relations practitioners in the field would most probably agree that general magazines are not the best option when looking at the media as a means of sending a message to external stakeholders. Should public relations practitioners consider magazines, they should think carefully about their message and concentrate on specialised magazines.

We will, however, look at the different magazines on the market and the way in which they operate, as this will broaden your knowledge of magazines.

Please note that this chapter does not include internal and external house magazines, but focuses on those that are not linked to the organisation and form part of the general print media.

What makes a publication a magazine?

Magazines have various characteristics distinguishing them from other publications. They are colourful and are normally printed in A4 format on good-quality paper. They appear weekly, fortnightly or monthly, are relatively expensive and rather thick, and contain lots of information covering almost anything under the sun. Magazines use lots of photographs and carry a high percentage of advertisements.

Because of their high production cost, magazines are normally sold at various points of sale and not, as in the case of some newspapers, distributed free of charge. They can also be subscribed to.

Types of magazines

As in the case of newspapers, it is no easy task to classify South African magazines according to definite categories. There are a few existing classifications (De Beer 1998: 110–117; Skinner, Von Essen & Mersham 2007), which we will examine below. These are not the only categories. There is scope for other, smaller categories.

Let us look briefly at examples of magazines in each of the following categories. They are almost self-explanatory and we will not discuss them in much detail.

Family magazines

Family magazines contain a variety of articles suitable for the whole family. This category includes magazines such as *YOU*, *Huisgenoot*, *Your Family*, *Bona* and *Drum*.

Women's magazines

Magazines focusing on women including *Fairlady*, *Rooi Rose*, *Sarie*, *Living & Loving*, *Destiny* and *Essentials*. The content of these magazines includes articles on fashion, skin care, food, health, diet, careers, etc.

Youth magazines

These magazines are aimed at teenage and young adult readers, such as *Seventeen*, *Saltwater Girl* and *Teen Zone*. There are also categories aimed at children, with magazines such as *National Geographic Kids* and *Supernova*.

Financial magazines

Magazines in this category are for business and financial people. They include publications such as *Financial Mail*, *Finweek*, *Fund Investor Insight*, etc.

Farming, agricultural and wildlife magazines

These magazines cover a wide range of subjects as South Africa is known not only for farming but also for its wildlife. Magazines in this category include *Farmer's Weekly*, *Landbouweekblad*, *SA Hunter* and *Game & Hunt*.

Business magazines

As this category indicates, these magazines include information on business, trade and industry. Some examples in this category are *Medical Chronicle*, *Analytical Reporter*, *Money Marketing*, etc.

Special-interest magazines

There used to be several special-interest magazines that covered miscellaneous subjects and did not fit a specific category. However, many more categories have emerged, such as sport, parenting, travel and leisure, motoring, mining, lifestyle, etc.

This section has online support material available.



Exercise

Take any two magazines and list five articles in each one. See if you can link the article to a certain organisation or company that may have been responsible for some of the information in each article.

Magazine 1:

Article	Organisation/Company

Magazine 2:

Article	Organisation/Company

Functions, readers and content

Although the main functions of newspapers (to inform, educate and entertain) also apply to magazines, there are major differences in the priorities allocated to these functions. Most magazines rely heavily on providing light reading matter of an entertaining nature. At the same time, they keep readers up to date with the latest information in various fields.

Considering the variety of magazines, it is not difficult to see that magazines are directed at certain markets. Although there are many magazines for specialist groups, eg financiers and professional people, most magazines cater for a large readership and include articles on a variety of subjects.

The content and layout of many magazines follow standard formulae. A magazine's table of contents, usually on the second or third page, lists its articles and columns. Certain standard pages are found in every edition, eg front pages, editorial pages, etc. These pages normally follow the same sequence in every edition, with regular articles or columns. The content of a typical women's magazine will include letters to the editor, fashion, cookery, short stories, etc, in the same sequence in most editions.



Exercise

Take three different editions of your favourite magazine and copy the table of contents of each one. Compare these and write down which ones can be considered as standard sections that appear regularly. Also, make a list of the articles categorised under each section.

Editorial structure and functions of each staff member

Magazines normally use freelance writers and photographers and research all possible sources for interesting articles. Much research goes into certain ideas to create or find a fresh, innovative angle. Standard media releases sent to magazines are often rewritten and published if they provide scope for another angle to be exploited. The permanent staff of magazines is trimmed to fill only the most important positions.

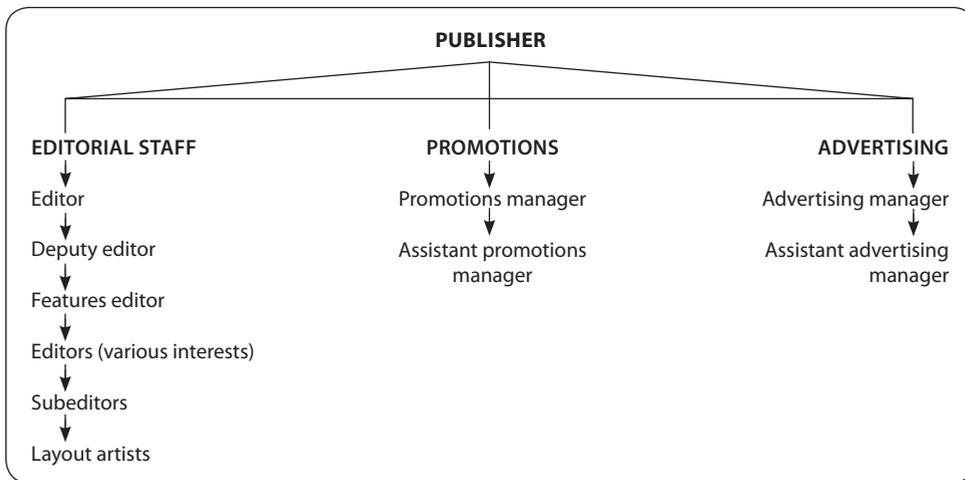

Figure 7.1 Organogram of a typical magazine

Functions of members of staff

Editorial staff

Each staff member's duties are clearly set out. The editor's role differs from that of a newspaper editor in that a magazine editor decides on the publication's content. He or she will suggest ideas or topics that have to be followed up by the editor responsible for material in that specific field. Each editor, eg features editor, art editor, etc, is responsible for editing articles for a specific section and liaising with the editor on the final product.

Promotions

Promotions are an important part of magazine publishing and are free publicity opportunities that provide added value for readers. A promotion could entail a competition offering sponsored prizes, eg an overseas trip sponsored by a travel agent. Staff in this section is responsible for writing promotional articles.

Advertising section

Staff of the advertising section of a magazine is responsible for selling advertising space. This section is of particular importance as income from advertising is used to cover part of the magazine's production costs.



Take note

Magazines are expensive publications. Although they are paid for by readers, their production costs cannot be covered if they do not sell advertising space.



Exercise

Use your own organisation as reference to:

- write a suitable article for a specific magazine about something new/unique in your organisation
- design and write a promotions article offering a prize.

Feature articles: articles that do not necessarily contain news, but give background information, comment, opinion, etc. Feature articles are suitable for magazines.

Blurb: summarises an article or photographic page and is printed in a box near the headline. It gives a brief explanation of the article or photographic page.

How magazines operate

Magazines operate slightly differently from newspapers for many reasons.

More preparation and planning are needed to fill a magazine than a newspaper. A magazine's *feature articles* are longer and need more research than those that appear in newspapers. Although magazines also work to deadlines, they do not experience the same rush as daily newspapers because they are published weekly, fortnightly or monthly.

Meetings are held to discuss the content of each edition. These meetings serve two purposes. They are held to determine the material available for the next issue, and new possibilities, material and requests are discussed. The editorial staff works as a team to fill each edition with quality material.

The editor should receive copy at least six to eight weeks before publication. Once a topic has been researched and the story has been written and approved by the editor, it goes to the subeditor for content editing, the writing of headlines and, if necessary, a *blurb* or information block.

From the subeditor, the article goes to the studio for layout. It is then sent back to the subeditor for copy-editing.

A publication must be print-ready and reach the printers at least two weeks before publication.

The public relations practitioner and magazines

Apart from specialised magazines that – in many cases – are the better option for public relations efforts, promotional articles in general magazines are another way of obtaining publicity for an organisation. Careful planning and thorough research are important. Magazine journalists and photographers should also be invited to social functions or important organisational events. However, the event should be unique, guests should include popular celebrities or public personalities and the occasion must offer possibilities for interesting articles.

Personal contact with magazine personnel is important. For example, a public relations practitioner working for a dairy or health product company should establish contact and build a relationship with a magazine's food or cookery editor. The public relations practitioner can then send regular media releases or stories to that editor.

If the public relations practitioner does not know anybody at the magazine, he or she should send a media release to the editor. Clear, appropriate photographs, contact persons and suggested angles for a story can turn a media release into an interesting article.

Submission dates and the frequency of publication are important, as they will determine whether your information is on time and relevant to the publication.



Take note

Public relations practitioners often have to comment on controversial matters. For example, suppose that a pharmaceutical product that caused the death of a patient is the subject of an investigative article and you, as a public relations practitioner, are contacted by a journalist who questions you on the use of the product in your hospital. In such a case, you need to be well informed or must ensure that your hospital's spokesperson is competent.

 **Summary**

Although the possibility of using magazines may appear remote for some organisations, it is still worthwhile to research their content and relevance as the opportunity to use them may arise unexpectedly.

 **Test yourself**

1. List the characteristics of a magazine.
2. List the different types of magazine and give examples of each.
3. What do you understand by the term promotions?
4. Explain the difference between promotions and advertisements.
5. Explain the role external magazines can play in public relations.

Introduction to the electronic media – television and radio



Objectives

After you have studied this chapter, you should be able to:

- discuss the television network of the SABC and other television networks in South Africa
- discuss the various radio networks in South Africa.

Introduction

In South Africa, most major cities have access to satellite communication. The South African Audience Research Foundation (2012) and Duncan (2009: 43) state that within South Africa radio has a reach extending to 93.5 per cent of the adult population and television has an 84 per cent viewership. Although technology has advanced at a rapid rate across the world, in South Africa there are stark disparities in terms of access to the electronic media (eg the Internet). However, smartphone and cellular technology is being used to access technology in both low- and high-income areas. Based on this, it is important for the public relations practitioner to be knowledgeable about and have an understanding of the various electronic media. This will ensure that the electronic media can be used to convey important newsworthy information to the target audience according to accessibility. This is important because in most cases, public relations practitioners need to demonstrate the value of managed communication and its impact on return on investment (ROI).

There are private television and radio stations in South Africa. Some of the key role players in television within South Africa are the public broadcaster SABC, commercial stations such as eTV and M-Net and satellite television such as StarSat (which replaced TopTV) and DStv. Public relations practitioners should consider using the services of the many commercial, community and public service radio and television stations.

The South African Broadcasting Corporation (SABC)

The SABC is South Africa's public broadcaster. These channels are broadcast free to air and all South Africans who own a television set have to have a television license.

The SABC is a public broadcaster and the services it offers can be used by public relations practitioners to reach a wide and diverse audience. The SABC's main functions are to disseminate information and provide viewers with educational and entertaining programmes.

The public relations practitioner's main involvement in electronic media will be influenced by the public broadcaster's information dissemination function. Public relations activities can and do relate to the SABC's educational and entertainment functions, but we will focus on its information dissemination function. We do so because the public relations practitioner's function is primarily geared to the dissemination of newsworthy information to the news and news-related departments of radio and television.

The SABC's head office at Broadcasting Centre in Johannesburg is one of the most modern complexes of its kind in the world, consisting of a 36-storey administration building and vast television and radio studio facilities.

The SABC has smaller broadcasting operations in all of South Africa's main centres and offices and studios in several towns and cities.

SABC news contact details

The SABC has its own website to reach audiences in varying ways. The SABC is also in the unique position to supply a broad range of news that includes both audio and video bulletins.

The main source of information for the sabcnews.com website comes from its own pool of reporters. The website taps into information that is gathered by SABC reporters and information obtained from the SABC's radio and television current affairs programmes.

The SABC call centre is the link between the public and the SABC. To inform the SABC of a news story, one can send an e-mail to tvnewsin@sabc.co.za or call the contact centre on 011 714 9797. The SABC's website can be found at <http://www.sabc.co.za>.

Ideally, the public relations practitioner should have a list of TV journalists' contact details on hand.

The SABC television network

South Africa has the largest television audience in Africa (South Africa online 2010). The SABC offers three free-to-air channels (SABC1, SABC2 and SABC3) and one pay-TV channel, SABC Africa. Along with eTV, SABC1, SABC2 and SABC3 are the only free-to-air channels in the country. However, in August 2014 the Independent Communications Authority of South Africa (ICASA) was reported to be planning to licence a third free-to-air terrestrial player to compete with the SABC and eTV. Industry watchers speculate that Kagiso Media and the Times Media Group may likely be interested bidders (McLeod 2014).

In July 2014, SABC1, SABC2 and SABC3 saw major changes in their prime-time line-ups to entertain viewers.

SABC1

The brand image of SABC1 is one of youthfulness. It provides a programming mix of enlightening, informative, educational and entertaining material. The channel target market is between the ages of 16 and 34. Broadcast languages are predominantly Nguni (isiZulu; isiXhosa; siSwati; isiNdebele) and English (SABC1 nd). It is more important for the public relations practitioner to note that the Nguni News slot has moved to a 19h00 slot.

SABC2

SABC2 is the SABC's family channel. It presents programming that focuses on nation-building, important national events and the sharing of experiences as South Africans. This channel

is a full-spectrum television service offering a programme mix of enlightening, informative, educational and entertaining material. The channel aims to promote social cohesion and nation-building through programmes that educate, inform and entertain through talk shows, soaps and documentaries. This channel is well known for its flagship *Morning Live* breakfast show (SABC2 nd).

SABC3

In July 2014, SABC3 adopted a new strategy with major changes to its line-up. Slot changes took place, coupled with new programmes. SABC3 took a new direction, shifting towards targeting a younger demographic. To ensure a balanced approach of telling authentic South African stories, this channel aims to acquire more local productions (SABC 2014).



Take note

While a basic knowledge of the different TV channels is important for the public relations practitioner, it is perhaps more important to take note of the programme listings of each channel to acquaint yourself with the news slots of each channel. If you aim to have your information broadcast on a certain day or at a certain time, you should be aware of the deadlines of the television news slots for your story to be broadcast in the news slot for which you are aiming.

We take a closer look at the television newsroom's functions and the television journalist's duties in Chapter 9.

Other South African television services

eTV

The first private television channel in South Africa, eTV was launched in 1998. It also offers full-spectrum programming and reaches about 78 per cent of South Africans. A black empowerment group, it is owned by Hosken Consolidated Investments Limited and Venfin Limited. Its offices in the main centres of Cape Town, Durban, Bloemfontein, Johannesburg and Port Elizabeth employ about 400 people (eTV Press Office 2014).

M-Net

M-Net is South Africa's first private subscription-based television channel. It broadcasts not only to South Africa but to 49 countries in Africa as well. Its programming mix includes movies, miniseries, sports and current affairs. It does not broadcast news.

Satellite television (DStv)

Multichoice was developed alongside M-Net to provide M-Net with subscription management services. It provides services to over 50 countries in the European, Mediterranean, African, Middle Eastern and Far Eastern regions (Skinner *et al.* 2010: 138). On 1 August 2013, the SABC launched its 24-hour news channel on DStv Channel 404, with news delivered in all 11 South African official languages. The SABC has 11 newsrooms nationally, each with the capacity to produce between 30 and 40 stories daily. With correspondents in other parts of Africa and overseas, SABC news can cover local and international news in detail (SABC nd).

StarSat

The former TopTV, StarSat is a South African satellite service that was launched in October 2013. It offers subscribers a range of different package choices to which they can subscribe (StarSat 2014).

The radio network

Radio continues to grow at national, regional and local levels, taking advantage of the new platforms of satellite, digital transmission and the Internet. One is now able to listen to radio on the airwaves, via satellite and on the Internet. Some of the main radio stations offer live audio streaming from their websites. Since 1994, a greater choice of stations and programming has become available.

The SABC used to be the only institution with a licence to broadcast radio services. In 1996, some of the SABC's regional (commercial) radio services – including Highveld Stereo, Jacaranda, Radio Oranje (now OFM), KFM, East Coast Radio and Radio Algoa – were sold to private broadcasters.

Such changes affect public relations practitioners. It is important that they inform themselves of these and other changes, especially

This section has online support material available.

as independent radio services increase and grow. The number of community radio stations is also increasing. Smaller areas, ie cities and towns, are the focus of these radio services. Public relations practitioners can use these services to great advantage.

Chapter 10 deals with the structure and functions of the radio newsroom and elaborates on how radio journalists work.

The media club of South Africa (2014) states that:

The corporation's public broadcasting arm includes cultural services in all 11 official languages, as well as stations for South Africa's Indian (Lotus FM) and San (XK FM) communities. By far the largest radio station in South Africa is Ukhozi FM, the SABC's isiZulu cultural service, with 6.38 million listeners a week.

Public broadcast stations currently include the following:

Table 8.1 Public broadcast stations in South Africa

Name of station	Language of broadcast
Ukhozi FM	isiZulu
SAfm	English
Radio Sonder Grense	Afrikaans
Lotus FM	English
Umhlobo Wenene	isiXhosa
Lesedi FM	Sesotho
Thobela FM	Sepedi
Motsweding	Setswana
Ligwalagwala	SiSwati
Munghana Lonene	Tsonga
Ikwekwezi FM	isiNdebele
Phalaphala FM	Venda
5FM	5FM is SABC owned. It is a youth station focused on all the latest youth trends, movies and music.

Source: The Media Club of South Africa (2014)

Commercial radio stations

Radio 702 and Capital Radio were South Africa's only independent radio stations during apartheid. After 1994, broadcasting in South Africa was deregulated. When this happened, many commercial radio stations started up. They have been successful in raising the profile of community projects.

Commercial broadcast stations include the following:

Table 8.2 Commercial broadcast stations in South Africa

Name of station	Type of offering
Metro FM	This is the largest national commercial station. Mainly broadcasts hip-hop, R&B and Kwaito music. It mainly targets black urban adults and is owned by the SABC.
Jacaranda FM	Mix of contemporary adult music. It is an independently run station. Its broadcast area is Gauteng.
East Coast Radio	An independently owned station that broadcasts a mix of music and news in English to the KwaZulu-Natal region.
Gagasi 99.5 FM	This station also broadcasts from Durban but broadcasts in English and isiZulu. It plays contemporary music with a strong focus on local identity.
YFM	This is a locally focused youth radio station. YFM plays 50 per cent local content and is known as the home of Kwaito. It is a Gauteng-based station.
94.7 Highveld Stereo	This station is based in Gauteng and plays a contemporary mix of music.
Kaya FM	This radio station has a mixed format of music and talk. Music is focused on adult contemporary and jazz and is African-focused.
Good Hope FM	This is the largest Cape-based radio station. The station's focus is a wide-ranging contemporary music base in the genres of R&B, ballads, hip-hop, dance and jazz.
Algoa FM	Algoa follows a music and news format and is broadcast in the Eastern Cape region.
Talk Radio 702	Based in Johannesburg, this talk radio format show is focused on current affairs and information station.
567 CapeTalk	This is the Cape version of Talk Radio 702.
Classic FM	As the name states the music is classically focused but the station also has business coverage and lifestyle features, sports and interviews.
KFM	Adult contemporary music in the Western Cape.
OFM	Adult contemporary music in the central region of South Africa.
Radio 2000	This station relies heavily on sports broadcasting.
Channel Africa	This is an international service owned by the SABC.

Source: SouthAfrica.info (2014)

Community radio stations

Community radio stations are smaller radio stations, so they find it difficult to access funding through high-volume advertising. However, community radio stations are an important part of broadcasting in South Africa. There are over 160 of these stations in South Africa. Some examples are:

- ▶ 906 FM Vaal Radio
- ▶ Radio Khwezi
- ▶ Bay FM
- ▶ Radio Laeveld
- ▶ Campus Radio
- ▶ Radio Panorama
- ▶ CCFM
- ▶ Radio Pretoria
- ▶ Fine Music Radio
- ▶ Radio Pulpit/Radio Kansel.

Regulating the industry

Broadcasting in South Africa is regulated by the Independent Communications Authority of South Africa (ICASA). The Independent Broadcasting Authority (IBA) was established to regulate broadcasting after 1994. The Independent Communications Authority of South Africa (ICASA) was established in July 2000 through a merger of the telecommunications regulator, the South African Telecommunications Regulatory Authority (SATRA) and the Independent Broadcasting Authority (IBA). ICASA is responsible for regulating the telecommunications, broadcasting and postal sectors in the public interest and ensure affordable services of a high quality for all South Africans.

ICASA also issues licenses to telecommunications and broadcasting service providers, enforces compliance with rules and regulations, protects consumers from unfair business practices and poor quality services, hears and decides on disputes and complaints brought against licensees and controls and manages the effective use of the radio frequency spectrum (ICASA 2014).

Summary

This chapter reflects the complexity of the electronic media. The SABC renders an essential service to a vast array of different target markets. The radio and television networks both broadcast in all 11 languages.

The main functions of the electronic media are to inform, educate and entertain. The information function is the one most relevant to public relations practitioners, as they should focus on programmes relevant to the dissemination of information. This function is located in the news and news-related programmes offered by the television and radio networks.

Test yourself

1. Discuss the SABC's television and radio networks.
2. Why is it important for public relations practitioners to align themselves with the public broadcaster's information dissemination function?
3. Discuss the independent radio networks.

Electronic media – television



Objectives

After you have studied this chapter, you should be able to:

- outline the structure of the television newsroom
- discuss the functions of the editorial staff and know whom to contact for newsworthy information
- assist the television journalist in obtaining information and visual material
- use different programmes for newsworthy information.

Introduction

Although television is regarded as the most powerful mass-communication medium because of its *audiovisual* impact, it is also the most difficult medium that the public relations practitioner has to deal with.

Owing to time constraints and the visual impact of television news, it is often found that bad news has a better chance of being broadcast than good news. Good news is something that normally happens, whereas bad news is abnormal and highlights issues of interest to viewers. Saying this does not mean that public relations practitioners should not endeavour to get good news stories onto television news broadcasts. Remember that any item might catch the editor's attention – as long as the information is newsworthy and of public interest.

Audiovisual: using material involving both sight and sound



Take note

About 95 per cent of stories submitted to television news by public relations practitioners are turned down. The main reason for this is that public relations practitioners disregard the newsworthy aspects of the information in favour of promoting a product or institution.

Although the main aim of public relations practitioners is to gain *publicity* for the institution they work for, the focus should still remain on the information's newsworthiness.

Publicity: public exposure

Television news is not only hard or bad news. It also includes soft news, such as human interest or animal stories. Most news bulletins end off with a soft news story.

This chapter details the newsroom's structure, explaining how the television journalist gathers information and visuals and how this material is prepared for broadcast. We also refer to other programmes that may prove invaluable to public relations practitioners should their information not be appropriate for television news.

As is the case with journalists of other media mediums, you must remember that social media plays a role in the TV journalist's profession in gathering information. According to CBS news anchor and reporter Sean McLaughlin, the changes brought about by social media not only impact the gathering and production of news, but job responsibilities across the entire organisation (Kamila 2013).

Structure of television news

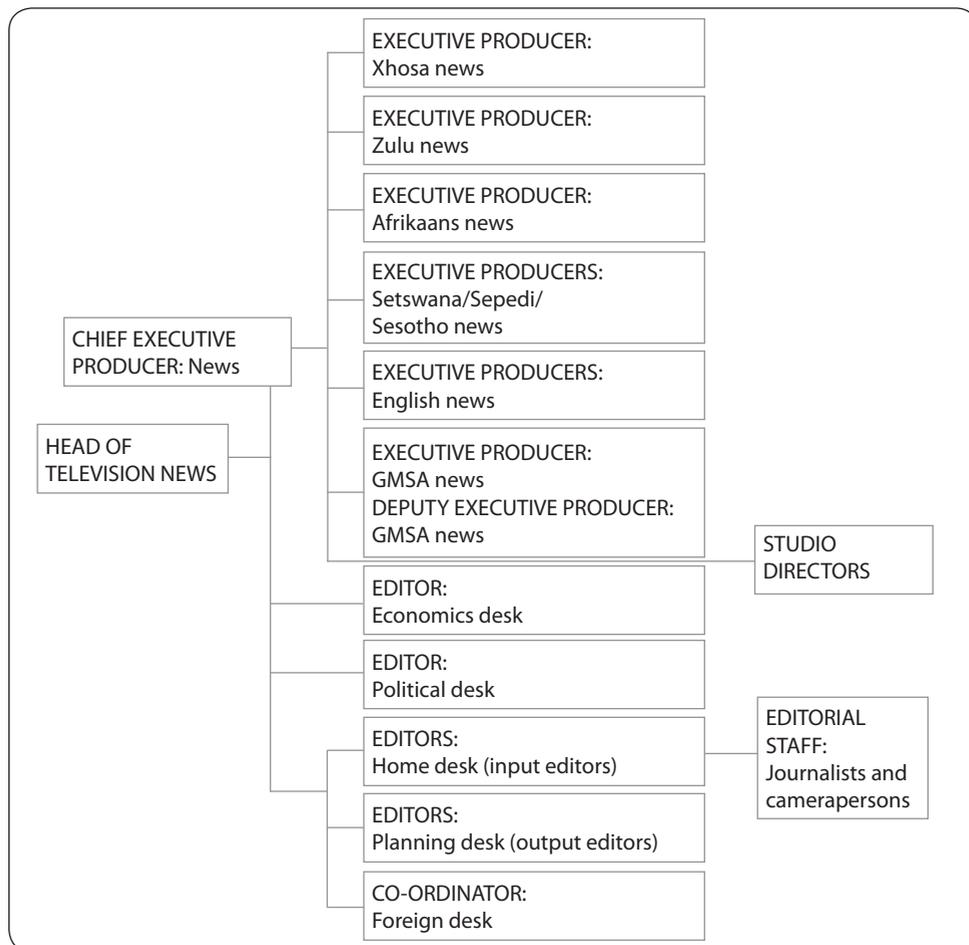

Figure 9.1 Television news – editorial structure

Functions of editorial staff

- ▶ **Head of news** – oversees news-gathering and production operations
- ▶ **Chief executive producer** – ensures accuracy, fairness, balance of news output as well as co-ordination between bulletins so that the line-ups of the different language bulletins are similar and also assists the head of news in overseeing news-gathering and production operation
- ▶ **Home desk** – receives incoming news and decides what news events to cover; responsible for assigning news stories to journalists

- ▶ **Planning desk** – responsible for planning ahead
- ▶ **Editors** – responsible for overseeing the coverage of events, eg economics, politics
- ▶ **Executive producer** – responsible for content and shape of bulletin
- ▶ **Studio director** – in charge of all studio operations
- ▶ **Journalists** – gather news, uncover stories through interviews and apply their language skills and news sense to get their messages across
- ▶ **Newsroom staff** – prepare stories filed by journalists for broadcast.

Although each person has his or her own specific duties, the final decision about the contents of bulletins is a joint decision involving each role player. Why is it important to know the structure of the television newsroom and the functions of its people?

Whom to contact

Look at the following scenario:

You are employed as a public relations practitioner for a large mining group. An underground rockfall at one of the mines has trapped hundreds of workers and the consequences could be fatal. Since you know that the SABC would be interested in covering this event, you decide to act proactively by contacting the television news department. Whom will you contact?

Your contact person is the input editor (indicated in Figure 9.1 under 'Editors: Home desk'). This editor plans the coverage of events for the day. He or she has direct contact with the journalists and will assign one and a camera crew to cover the disaster. If you have already established good relations with a journalist in the television news department, you could inform that person directly and he or she will give the editor all the relevant information. The input editor decides whether the story deserves coverage. If you cannot contact the editor or your contact journalist, you might then contact the chief executive producer of news, who will arrange for a journalist and a camera crew to go out to the mine.

Public relations practitioners often make the mistake of contacting several news people, eg the chief executive producer, the editor and a journalist, to ensure that the message is received.

Such multiple contacts are not desirable as these people liaise closely with one another. If you reach the editor, he or she will inform all the other role players of the event.

How the television journalist works

Knowledge of how the television journalist covers an event will assist the public relations practitioner in helping the journalist obtain the necessary information and visual material.



Take note

The public relations practitioner should see to it that traditional 'Who, What, Where, When, Why and How' questions of journalism (the 5Ws + 1H) can be answered as this will help the journalist to grasp the facts central to the event immediately.

The journalist is a professional who can judge the news value of a story, distil its essential facts and arrange the information in a way that makes it comprehensible to viewers. This is especially true when the story is fast breaking. Since journalists know what they want, public relations practitioners should be objective and help them to obtain all the necessary information, not just what they want to give. Every pitch should include some sort of web element, such as pictures or video clips, which helps the TV journalist to visualise the story that will be broadcast on air, website, social media, etc. At the same time, TV news is also constrained by time: pitches that are too long will not be used (Kamila 2013). The following description will give you an idea of how the TV journalist functions.

While gathering information, the journalist makes notes. At the same time, the cameraperson will record essential visual material and various other shots that may be used to tell the story. The journalist may also choose people to interview on video.

When the journalist is satisfied with the notes and visual material, he or she may file the report on camera at the scene. This is usually done to close the report.

Back at the office, the journalist and the newsroom staff view and edit the tape. The journalist then writes a script that will be used to mix the direct address made to the camera by the journalist (stand-ups) with the interviews (sound bites).

The newsroom staff then compiles the various packages (reports that need a lead-in by the news anchor) and other items for the bulletin that will be presented by the news anchor (person reading the news). Below is an example of a news bulletin, ie the final product.

ESHIP A
E-SHIP
NEWSCAST = 2000
WRITER = MUNGO
PRESENTER = Jane

<p>VIDEO</p>	<p>SOUND</p> <p>(*** SHIP ***) (*** Jane ***) The British frigate HMS Edinburgh – that’s been anchored in Durban harbour – for the past three weeks – is making final preparation before heading off for open sea tomorrow. Today its sailors gave a demonstration of their skills. (*** TAPE ***)</p>
--------------	--

ROLL TAPE # = 59 (DUR = :44)
UPS DUR = :44
IN CUE = The British warship . . .
SUPER = 5-Leizl Olivier/reporting/Durban;0004
SUPER = 2Sub-lieutenant Ivor Humphreys/HMS Edinburgh; 18-22
OUT CUE = . . . the ship will return to the UK in march.
TOTAL = 01:00
DATE = 9/1
SOURCE = Leizl

Figure 9.2 Example of a news bulletin

General tips for the public relations practitioner when dealing with television journalists

The TV journalist represents image and sound. When dealing with journalists the public relations practitioner must make provision to cater for their needs, whether it is via media releases, personal contact or through social media platforms. Information alone is not enough – you have to support the information with visuals of good quality. A blurry, unprofessional, long-winded video will not make it onto TV news.

A television journalist's work is complex. Television news revolves around content and, ultimately, is judged on its picture content. Similarly, the value attributed to news items on any given day is determined by its newsworthiness. For example, if a news conference is scheduled for a certain slot but an unexpected explosion occurs, the news value of the explosion is more than that of the news conference. However, if the news conference was held to announce a new, proactive anti-crime campaign by the national police commissioner, it might still be viewed as the news of the day.

Public relations practitioners are often disappointed when they receive no television coverage of an event that was scheduled. Often the reason is that the initial news value for that day has changed because of other more important events.

Television news falls into the following categories:

- ▶ Hard news with no visuals
- ▶ Hard news with visuals
- ▶ Soft news with no visuals
- ▶ Soft news with visuals.

It must be borne in mind that the intrinsic, visual nature of television elevates the importance of visual material. The public relations practitioner must also be able to determine whether hard or soft news without visuals will be accepted on the strength of its information alone.

Objective: facts
uncoloured by feelings or
opinions

The public relations practitioner's main role is to help the television journalist gather information and visuals. The journalist may need access to restricted access areas, eg a hospital's operating theatre, and it is up to the public relations practitioner to arrange access. It should be explained to journalists that they have to abide by regulations when entering such areas and that if they do not agree, they may be barred from entering.

Television journalists expect transparency from public relations practitioners conveying information. The reportage of journalists has to be *objective*, and the more information – good or bad – that public relations practitioners give, the more trust they generate as a reliable news source.

The public relations practitioner, as a spokesperson for an organisation, should have information readily available whether an event is expected or not. He or she should be able to answer any questions since journalists will not provide a list of questions beforehand. Public relations practitioners may ask journalists which angle of the story is being pursued, which gives them a few minutes to prepare for such questions.

Although television journalists may spend some time obtaining information and visuals for a news report, only a few minutes are eventually broadcast. This happens even when they cover a scheduled news event taking as long as two to three days. Public relations practitioners should therefore be aware that many hours, even days, may be spent with television journalists for only a few minutes or seconds of broadcast time.

Because of the technical complexity of television news-gathering, public relations practitioners must be aware that special provision should sometimes be made to enable television journalists to compile a package. For example, a news conference where an announcement is made about a low-cost housing project may not be visually acceptable to them and they might request to be taken to the area where the houses are to be built. A television crew is therefore handled differently from other media and the situation or event will dictate whether special arrangements need to be made for television. It is not always possible to do so.

However, public relations practitioners should be careful not to give television journalists overly favourable treatment, as representatives of the other media might feel that they are favouring television

unduly. When giving information, public relations practitioners should ensure that all representatives of the different media receive equal treatment, even if the way in which the information is conveyed differs from one medium to another.

Categories of television programming

In the previous section, one category of television programming, ie news, was discussed. If a public relations practitioner's story is broadcast on a television news bulletin, it can certainly be viewed as a great achievement.

In some cases, you may not be sure whether the information you have is suited to television news. If you are unsure, you should contact the input editor and discuss the matter with him or her. The input editor may see certain aspects of interest that are relevant to the news, or suggest that the information be relayed to another television programme.



Take note

Do not make a habit of discussing your stories with input editors. Remember that they have an extremely busy schedule and receive countless telephone calls daily. Do not waste their time and only contact them for advice as a last resort.

Good public relations practitioners should be able to decide whether their stories warrant television coverage. In weighing the options, they should be aware of other programmes that are available.

Television programmes are categorised as follows:

- ▶ Sport
- ▶ Variety and music
- ▶ Magazine and documentary
- ▶ Drama
- ▶ Religious
- ▶ Youth and children
- ▶ Educational
- ▶ Ecology.

Deciding on the most appropriate category can be very difficult, and the following criteria must be considered:

- **Audience:** This is probably the most important criterion. You need to know who your information is aimed at. Taking the diverse South African markets into consideration, you need to define your audience. If your information is aimed at the youth, you will find a youth programme more appropriate than, for example, a documentary programme.
- **Content of message:** The type of information you wish to convey will assist you to choose the most suitable programme. Your message aimed at the youth may be religious in nature, so another option open to you would be a religious programme. To decide between a youth and a religious programme, the next criterion must be met.
- **Time:** At what time is the programme broadcast? If you want to target the youth through a religious programme, and these are televised on weekday mornings when scholars are at school, a religious programme is the wrong choice. You must then look at a youth programme televised in the afternoon or early evening.
- **Language:** This is another very important criterion. If you wish to reach the isiZulu-speaking youth and your insert's content is of a religious nature, you will have to find a religious programme or a youth programme presented in that language.

You can see how difficult it is to make the right decision! It is therefore also very important that public relations practitioners use the various sub-departments in the different categories of television programming. They should make contact with the programme organiser to ensure they have made the right decision.

Public relations practitioners must remember that it is possible that, if their information has initial news value, it may be useful for programmes featuring in-depth reportage or debate.



Exercise

Read the two scenarios below and discuss the type of programme or programmes you will choose, using the following criteria:

- Target audience(s)
- Content of message
- Time slot
- Language.

Scenario 1

As the public relations practitioner of a tertiary educational institution, you wish to inform potential students about the various educational programmes offered by your institution so that they make the correct career choices. Considering the above criteria, explain how you would choose the correct programme.

Scenario 2

You are the Road Safety Council's public relations practitioner. Because of the many pedestrians killed or injured on the roads, the council has decided to embark on a massive safety awareness campaign. Using the above criteria, what type(s) of television programme(s) do you think would be suitable for this campaign?



Summary

This chapter dealt with the structure of the television newsroom and the editorial staff's functions. Public relations practitioners should know whom to contact at the television newsroom when they have information suited to television news.

Knowledge of how television journalists operate when covering an event is important since public relations practitioners should be aware of journalists' needs.

Although public relations practitioners usually target the newsroom in an effort to gain publicity or to convey information of national interest, they must remember that there may be other programmes suited to promoting their message. When dealing with television journalists and knowing the visual aspects of television journalism, public relations practitioners should be prepared to afford them individual attention.



Test yourself

1. Outline the structure of the television newsroom and indicate the functions of each editorial staff member.
2. Whom will you contact at the television newsroom when you have newsworthy information?
3. Discuss how television journalists operate when covering an event and explain how the public relations practitioner can assist them.
4. What would your reaction be if a television journalist requests to be treated differently at a news conference? Support your answer by providing reasons.
5. List the various television programmes, other than the news, that the public relations practitioner can use.
6. List and discuss the criteria that the public relations practitioner must consider when choosing the most suitable type of programme to use.

Electronic media – radio



Objectives

After you have studied this chapter, you should be able to:

- discuss the functions of the editorial staff of radio news and know whom to contact with newsworthy information
- assist the radio journalist by providing and gathering information
- use various radio services and radio programmes to convey newsworthy information.

Introduction

Radio is one of the fastest and most effective mediums to use when the public relations practitioner needs to convey information. As an established communication medium, it has a reach of 94 per cent of the adult population. It is a cheap and easily accessible medium for people from all walks of life. One of the most important attributes of radio is that, unlike television, it is portable and is therefore an ideal way to target an audience to gain publicity. Most commuters listen to the radio on their way to and from work. Radio stations and disc jockeys are also very active on the various social media platforms.

Many radio stations, the various programmes they present as well as the hosts of the various shows have Twitter handles and Facebook pages. Many provide live streaming from their studios where audiences can see what is happening within the studio. In addition, many of the most popular radio stations are available online. SouthAfrica.info (2012) explains how, via

live audio streaming, an individual can listen to his or her favourite radio station anywhere in the world. You can listen online via your tablet or cellphone by downloading the relevant applications where needed. This means that radio has become even more accessible.

The advantages of radio over television and the print media are that radio provides regular news broadcasts on various channels throughout the day and also has continual updates via social media such as Twitter. Many radio stations also tweet and broadcast live from important events.

Take, for instance, the trial of Paralympic athlete Oscar Pistorius. Radio journalist Barry Bateman, who works for Eyewitness News, saw an increase in Twitter followers as a result of his live tweets of the bail hearing and court case.

Radio is accessible and in this regard is able to reach communities that are hard to reach, such as those in remote areas. South Africa also has a high illiteracy rate and radio is accessible to those individuals who would not be able to receive news in print. Although television also enjoys this advantage, it is not as accessible because it is more expensive than a radio and also consumes more electricity. There are 15.4 million radio sets in South Africa and over 30 million listeners listening to various radio stations. South Africans spend three and a half hours a day listening to radio (SouthAfrica.info 2014). This shows how important a resource radio is for a public relations practitioner.

As radio is the fastest and most effective means of conveying information to the public, the public relations practitioner must be aware of the time constraints related to messages. If a message needs to reach the public within a specified timeframe, radio is the best medium to use. Although each service has its own time slots for news broadcasts, regular programmes may be interrupted for special news broadcasts if the information demands it. Take, for example, news about the attempted assassination of a dignitary. This will be broadcast immediately, even if the news is received outside a scheduled news broadcast.

Public relations practitioners should acquaint themselves with the news programmes of the various radio services and identify these services' target markets. The type of message will, to a great extent, determine the target audience that needs to hear it.

Although radio news may be more accessible than television news, it is a more difficult medium to use than newspapers. Time is limited on radio news bulletins and where a few seconds of airtime may be available on television news slots, this may not be the case on radio. Furthermore, because radio listeners are spread over several stations, a message may have to be aired on several stations to reach the desired target audience. Radio listeners cannot go back to review important points. It is also important to remember that radio is a background medium. Most listeners are doing something else while listening, which means that a message has to work hard to get their attention.

Public relations practitioners have to be certain of the news value of their information before contacting the radio station. It is also important to distinguish between newsworthy information for national, regional or local radio programmes.

The best way to become acquainted with the radio as a medium is to listen to the various radio services and the programmes they offer. The marketing section or public relations practitioner at the various private radio stations as well as the SABC's Radio Services Directorate are good contacts for publications on radio programmes, which are useful as they contain information about the nature of the available radio programmes, what their aims are, and who their target groups are. The Radio Services Directorate also generates statistics detailing and profiling each programme's listenership, which give an indication of the audience that can be reached.

The following discussion of the structure of a radio service or station, the newsroom and the editorial staff's functions is aimed at providing the public relations practitioner with a basic knowledge of the radio as a mass-communication medium. It will include comments on the way that radio journalists work and how the public relations practitioner can assist them. Other programmes of use to the public relations practitioner, such as talk shows and actuality programmes, are also mentioned.

Structure of the radio service

Studying the structure of public service radio will show how a radio service's various departments can be of use to public relations. In the following diagram the departments and the programmes available in each department are illustrated.

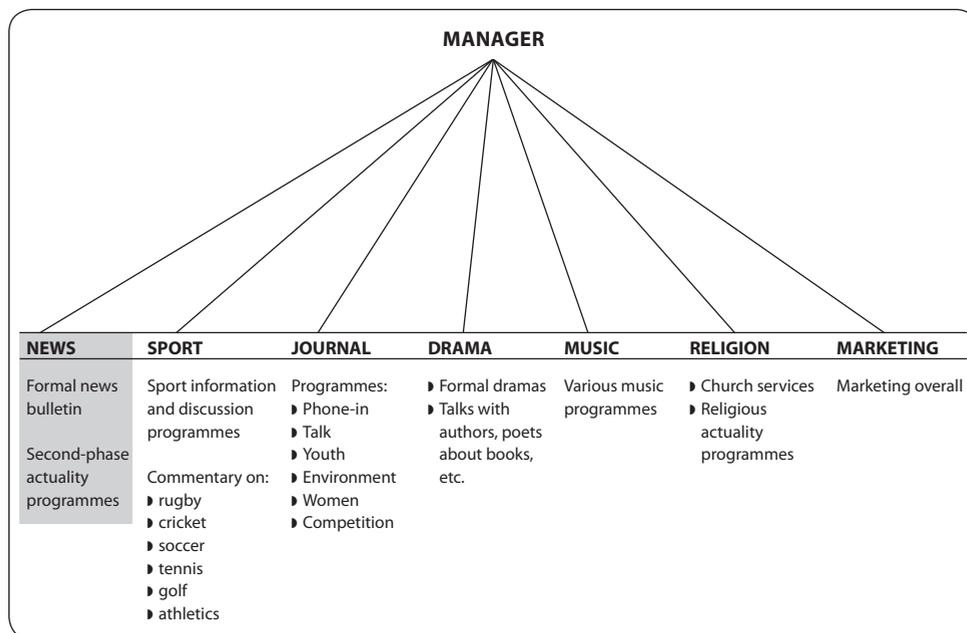

Figure 10.1 Public service radio



Take note

Each of the departments shown in Figure 10.1 is run by a producer and each programme within the department has an announcer. Announcers constantly look for stories and information to use in their programmes and public relations practitioners must decide where their information fits in.

The following section will focus on the news department, where formal news bulletins and second-phase actuality programmes feature. (See the shaded area in Figure 10.1.) It will be followed by a discussion on the ways that other programmes can be used by the public relations practitioner.

Radio newsroom

Radio news and actuality programmes are compiled by editorial staff, including executive producers, editors, senior journalists, journalists and junior journalists.

The functions of the editorial staff are as follows:

- ▶ **Executive producers** control the news and actuality programmes and are responsible for all the news bulletins and actuality programmes broadcast on the various services.
- ▶ **Editors** are responsible for specific programmes and decide what will be broadcast. Editors are also responsible for quality control.
- ▶ **Senior journalists** are responsible for in-depth reports.
- ▶ **Journalists and junior journalists** are responsible for the daily gathering of newsworthy information and may also do investigative journalism.

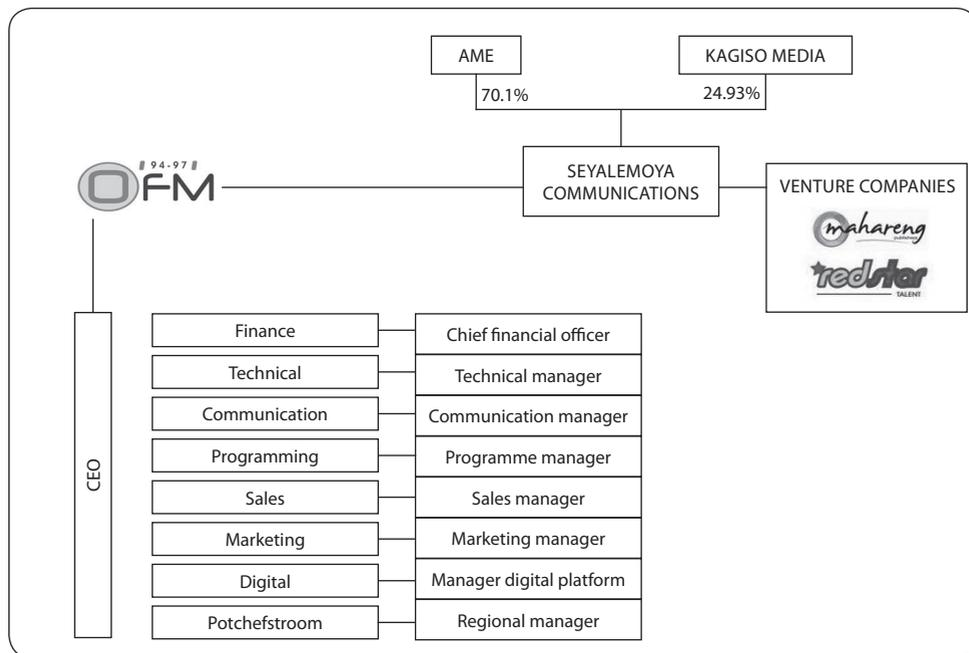

Figure 10.2 Organogram 2010-03-25 (courtesy of OFM)

Radio news regional editors

Regional radio is an important outlet for radio news. There are several local regions to which news from those areas can be broadcast. In these regions, regional editors decide what information is to be used in news bulletins.

The general radio news offices are:

- Gauteng – Johannesburg
- Gauteng – Pretoria
- Western Cape
- KwaZulu-Natal
- Free State
- Eastern Cape
- Limpopo
- Mpumalanga
- Northern Cape
- North West

Whom to contact

If public relations practitioners have well-established contacts in the newsroom, they may contact the relevant journalist directly, who will in turn brief the editor. Alternatively, public relations practitioners may contact the news editor, who will have a journalist contact them for the information. The same rules applicable to television apply here – do not contact various people in an effort to have information broadcast.

If public relations practitioners have information of regional value, the person to contact is the regional editor.

How the radio journalist works

The radio journalist has the same responsibilities as the print journalist in terms of collecting, collating and then reporting the news in a local, national or worldwide capacity. A good radio journalist will typically use interviews, press conferences and sound effects to make listeners feel as though they are also on the scene. The difference between radio journalism and other forms of journalism is that a radio report is often heard once and then it is gone, so radio journalists have to make sure that their stories are concise, brief and easily understood. Like a television journalist, a radio journalist often presents the news live (WisegEEK.com).

Public relations practitioners should know how radio journalists work and what their requirements are when covering an event or when gathering information.

It is as important for the radio journalist as it is for journalists from any other medium to gather information according to the traditional 5Ws + 1H (Who, What, When, Where, Why and How). Since airtime is limited, answers to these questions can help

the radio journalist to summarise events quickly and compile a radio report based on the salient facts. As radio news is written for the ear, short sentences and simple language are used.

A news bulletin is compiled from the various stories received from journalists and is then read by the studio's anchor person. The following is an extract from such a news bulletin. It represents the result of the interaction between the public relations practitioner and the journalist.

IN THIS NEWS BULLETIN.....

The police keep a close watch on the Central University of Technology campus AND The students of the University of South Africa protest against increased tuition fees. DETAILS COMING UP

bfm

The Central University of Technology campus is tense this morning with a strong police presence on the campus. A police spokesperson says that they will arrest anyone who contravenes an interdict prohibiting the disruption of lectures on campus. Earlier today about 200 students waited outside the administrative buildings. However, there have been no reports of incidents.

boycott

Students of the University of South Africa are staging a one day boycott in protest against increased tuition fees. They're also unhappy about the failure of the tertiary institutions to admit all students. Students are picketing and chanting songs on the university campus.

anthony, pretoria/korrie mthethwa 21/02 pks/metro

THIS BULLETIN WAS WRITTEN AND COMPILED BY

.....
THE NEXT NEWS UPDATE WILL BE AT ONE

Figure 10.3 Extract from a news bulletin

When a journalist uses a device to record an interview, he or she should disclose this to the interviewee and explain that the recording will be used in two ways: to write his or her story, interview or news clip, or to be edited in the studio for parts of it to be used for sound bites within the news bulletin. Radio news bulletins do not usually include recorded interviews, although one or two sentences might be included in the bulletin – but only if the interview gives a news story additional impact.



Take note

Another way to gather and convey information is by reporting live. Radio journalists are usually equipped with a cellphone when on a live reporting assignment. The journalist is then linked to the news anchor in the studio by telephone and the report is broadcast live. This type of reporting is appropriate for actuality or current affairs programmes, but can be used effectively in normal news slots if the event warrants it. For example, a huge mountain blaze endangering people's lives can be described by a reporter against the backdrop of wailing fire-truck sirens, creating a word picture in the listeners' mind. Such reportage of dangerous situations has immense impact on a news slot.

Categories of radio programming

Although public relations' efforts are directed mainly at news bulletins, there are other programmes that public relations practitioners can use just as effectively. Figure 10.1 illustrates departments focusing on sport, journal, drama, music and religion, which public relations practitioners can use in order to decide whether their information is of use to any of the programmes in these departments.

Types of format

Radio stations have news, current affairs and informational programmes, some of which include phone-in programmes. Music and talk-show formats tend to dominate the public commercial stations. The main format for the public service programmes are interviews combined with phone-in programmes.

You need to familiarise yourself with the different radio stations that will be most beneficial for the type of information you wish to convey and the target audience at which the information is aimed.

The following example illustrates how different programmes can be used for public relations purposes.

You are the public relations practitioner in the Ministry of Sport and Recreation. The Minister is about to announce the building of five state-of-the-art sport stadiums in disadvantaged communities that will host both soccer and rugby games in either a closed or open air stadium environment. The Minister's initial announcement is hard news and therefore important material for a news bulletin. Firstly, contact the news editor, who will assign a journalist to the story. The news broadcast can then be followed by an actuality programme where, for example, experts will discuss the impact of the stadiums on the communities in which they will be built.

You can go further and contact the programme announcer. Offer the announcer the opportunity to talk with the relevant decision-makers on the merits of building these new sports stadiums. Now you can telephone the announcer of the talk-radio programme. Arrangements can be made to invite an architect and engineer to tell listeners how the stadium will be built, etc.

This example illustrates how a single announcement, ie the building of a state-of-the-art sport stadium, can be used in several programmes. The Minister's initial announcement was hard news. This was followed by second-phase journalism in the actuality programme and the softer story describing how the stadiums would be built. The secret is to think laterally – a single story has many sides.



Exercise

Suppose that, after the announcement of the death of the honourable Nelson Mandela by South African President Jacob Zuma on 5 December 2013, you were given the task of managing the public relations activities on behalf of the government.

Which radio interviews and radio talk shows would you identify as the appropriate ones to grant interviews to? List the programme types and types of interview that you would have approved under these circumstances.

Time schedules

Public relations practitioners should note that radio works according to the clock, as does television. If a programme is scheduled for 08:00, then it starts at 08:00. If you have arranged for a spokesperson to be at the studio at 08:10, see to it that the person arrives at the studio at 07:50. Not only will the person be in time for the interview, he or she will also have time to relax.

Punctuality and readiness also apply when you or a spokesperson is scheduled to record a telephone interview. The journalist or announcer will arrange to telephone you at a set time to record the interview – make sure that you are waiting for the call.

How public relations practitioners can assist radio journalists

It is important to realise that journalists from the electronic and print media all have their own requirements.

Radio journalists work with sound only. If the radio journalist wants to interview the public relations practitioner or the head of the organisation, the public relations practitioner must allow for the fact that the journalist will need a quiet area to record the interview and arrange a quiet venue for it.

When journalists telephone you for information and do not use a recording device, give them the necessary information so they can write a report for use in a news bulletin.

If a radio journalist telephones you to request a telephonic interview to be recorded in the studio, ensure that no interruptions take place during the interview. Root (2009) offers five techniques for successful radio interviews that are discussed in the sections below.

Avoid over-preparing

You should aim to sound informed and prepared, and should anticipate the kinds of questions that the radio journalist is likely to ask. You should also think about the way in which you plan to convey your information so that you do not sound as if you have been caught unawares by any of the questions you face. However, over-preparing will make the interview sound rehearsed, and you want to sound as spontaneous as possible.

This conveys the impression that you understand the issue and the business very well. Avoid rushing into answers – think for a moment about what you want to say, and how you want to say it, before you respond.

Phone-in shows

The radio station may give you the chance to interact with the public directly by allowing members of the public to call in and speak to you on air. This is a good opportunity to make meaningful contact with the public and to dispel any myths or preconceptions about the issue or organisation. Ensure that you take notes while callers are speaking so that you can address all of their concerns. Keep your answers short and succinct, and phrase them in such a way as to discourage callers from raising further questions. Do not enter into a confrontation while you are on air.

Have your message ready

Write down a few key aspects that you want to convey during the interview ahead of time, as the interviewer may not ask you all of the questions that allow you to convey your message in your answers. Keep these statements short and succinct, and expand briefly on them if the interviewer does cover all of the bases in the interview. Such an opportunity may not arise often, so make the most of it.

Securing radio interviews

Securing radio interviews is a common challenge faced by many public relations practitioners. Consider the following when attempting to get radio publicity interviews as an interview guest to promote your organisation:

- ▶ Identify radio shows that book guests for interviews.
- ▶ Find contact information for the radio show's producers.
- ▶ Create and send a targeted pitch – call the producers to offer information that is new. Your pitch should be aimed at getting their attention and should fit into their current radio show programming needs.

Placing your message or corporate advertisement on radio

Planning is crucial should public relations practitioners consider placing messages or corporate advertisements on radio. They should be fully informed about how radio functions and be familiar with the key personnel associated with radio. Consider the following (adapted from Entrepreneur.com) when planning to place your message or corporate advertisement on air (remember that newsworthy messages are free publicity while corporate advertisements are paid for):

- ▶ **Define your target market.** Think about who your stakeholders are to determine the audience you want to reach. Make sure that you select the best radio station and programme for conveying your message.
- ▶ **Determine a reasonable budget.** While radio costs less than television, it can still be costly, especially when you need to run your corporate advertisement for the recommended period of at least three months. Find out about the rates for the radio station and programme you plan to use, as rates vary significantly depending on the size of the radio station and the numbers of listeners it reaches.
- ▶ **Contact sales managers at television and radio stations in your area.** These are the people who can give you information about the slots that are available on the kinds of programmes you plan to use.
- ▶ **Find out about the 'audience delivery' of the spots that are available on your chosen station and programme.** Then calculate the *cost per thousand (CPM)* of reaching your target audience. This calculation will help you to determine the cost of reaching a specific target audience. While it seems that you are buying time on a radio programme, you are, in fact, buying the audience who is listening to the programme during that time.
- ▶ **Compare the proposals you receive from different stations and programmes.** Once you have studied the CPMs, you can negotiate the best deal, which is the most cost-effective way of reaching the largest possible audience. You can reduce costs by buying time well in advance.

CPM: a way of calculating the advertising cost of purchasing 1 000 units of audience. You calculate CPM by dividing the cost of the media unit by the number of audience members (in thousands). 'M' here is the roman numeral for 1 000.

Summary

Knowledge of the newsroom's structure and the editorial staff's functions will assist the public relations practitioner in conveying information to radio news.

Public relations practitioners should always be aware that radio provides various publicity opportunities. News bulletins fall into only one category that can be used. Public relations practitioners should acquaint themselves with the many radio services and radio programmes that can be used most effectively.

Test yourself

You are the public relations practitioner at Gray Hospital where two South African doctors have just done the first successful fully synthetically engineered heart transplant on a six-month-old baby. The operation was a huge success and the young patient is extremely healthy. Since this type of operation usually poses great risks, the fact that the patient survived the operation is already of great significance.

Keeping in mind that this is newsworthy (and could generate interest in other programmes), discuss how you will go about informing radio services' news departments and other programmes of your choice.

You must indicate specific radio services you will use for the news angle and those that you will use for the human-interest angle. Support your choices by providing reasons.

Digital or new media



Objectives

After you have studied this chapter, you should be able to:

- define the concept digital media
- explain what the advent of the Internet, e-mail, the World Wide Web, mailing lists and news groups represent in communications
- discuss in detail how public relations practitioners apply digital media in executing their technical role.

Introduction

These days, public relations practitioners, along with other communications practitioners such as journalists, will not be able to do their jobs professionally and resourcefully without using new media tools. These are now more commonly referred to as technology-driven digital media and social media. Digital or new media can be seen as the overall umbrella term for all newer forms of media, ie non-traditional media.

Social media: platforms that you can use to create, share and exchange information by means of virtual networks and communities



Take note

When the text refers to new media, it is used as a synonym for digital media.

Chapter 12 focuses on *social media*, which is one of the digital or new media channels. Technology and its various platforms change almost daily. It is up to you to keep abreast of these

changes and to adapt your work situation, your communication strategy and needs accordingly. The aim of this chapter is to create an awareness of the existence of digital media tools and to encourage you to make use of them, especially in your dealings with the mass media. Using these tools will enhance your knowledge of new technology and will provide you with time-saving communication with the representatives of the various mass media.

However much the application of new media applications, platforms or tools may provide you with faster and more efficient communication, it is important not to neglect face-to-face contact and traditional media when you are planning a public relations strategy. You also need to keep your face-to-face contact with stakeholders and journalists.

What is digital or new media?

The term new media was coined to differentiate between the traditional media world of print, radio and television and the new media world of computerised electronic publishing using a multimedia combination of print, audio, video and digital images on the Internet and other digital formats. Because of the digital format, the term digital media is now more commonly used.

The arrival of these new technologies in the 1990s radically transformed every aspect of communication, including how we communicate, where we communicate and with whom we communicate.

The most obvious place to start when discussing digital media is the Internet and the World Wide Web. E-mail, mailing lists, news groups and social media platforms are regular public relations tools. Furthermore, the wireless and mobile communications revolution has taken the communications industry out of the office and into the real world. Wireless technology has become an indispensable tool in the weaponry of public relations practitioners, journalists and other communications practitioners.

McLuhan's global village

It seems that the world has moved amazingly close to realising Marshall McLuhan's global village. In his book *The Medium is the Message*, which was first published in 1967, McLuhan speaks of

living in a global village where things happen simultaneously all over the world. Time and space no longer have any significance.

Not only is there a new multisensory view of the world, but people from countries around the world can communicate as if they all live in the same village.

When McLuhan outlined this global village vision more than 40 years ago, the Internet, the World Wide Web, smartphones and other modern-day digital gadgets did not exist.

The Internet and World Wide Web and other contemporary digital technology provide the means for diverse people to communicate their messages with no boundaries to a global audience. It has allowed for anyone to become an author as long as they have connectivity. Every site on the World Wide Web is available to anyone who has a device and connectivity.

Time and space become insignificant, as a click can take you to a site halfway around the world through search engines such as Yahoo and Google. A search engine searches for information on the World Wide Web (Fielding & Du Plooy-Cilliers 2014: 322–324). It presents a web of interconnected documents straddling the globe. Thus, the Web becomes the global village square, where everyone meets to communicate and exchange information. The invention of digitised, wireless and satellite technology has played a role in revolutionising the 21st century just as traditional communication did previously.

Public relations and digital or new media

It is important to investigate how public relations practitioners can use digital media to improve the service they provide as company journalists or as public relations consultants.

When comparing traditional and digital media in public relations, it is clear that things have changed dramatically. Previously the public relations practitioner only had traditional means of distributing his or her messages and could only use traditional media in his or her public relations, communication or media strategies. This was expensive and relatively slow.

It needed to be planned far in advance; in the case of some mediums such as magazines, it could take up to three months for the information to be published. With the advent of digital

media, messages can be disseminated far more cheaply and quickly than through traditional media. The public relations practitioner can update a website whenever needed, send out tweets or post on the company's Facebook page, and use or provide digital images. This can happen over a wide spectrum and have a wide reach.

The methods used to collect information, the way the information that has been gathered is interpreted, and the mode of transmission of electronic information have all changed significantly.

Single-level presentations, ie using a speaker to address the media during a public relations product presentation and afterwards giving the media representatives a press kit, formed part of the traditional media world. Nowadays, with the sophisticated technology available to communications practitioners, information is presented in a multilayered fashion to a target audience using a combination of video, audio, text and data. Furthermore, the audience can watch the presentation and even participate in the event from another continent, due to the interactive quality of digital media.

One can reach a global audience instantly. The target audience can log on to the Internet, search the World Wide Web, participate in an interactive multimedia tour of the company's facilities or watch a pre-recorded video of the specific service or product offering. They can read about the latest international research done on the product, view digital photographs of it and listen via streaming audio or podcasts to a number of experts in the field discussing the findings of the new research. Visitors to the company website can even post their own electronic messages to the experts via e-mail and receive immediate responses.

Table 11.1 Some advantages and disadvantages of digital media for public relations

Advantages	Disadvantages
<ul style="list-style-type: none"> ● Direct connectivity with your target audience. 	<ul style="list-style-type: none"> ● Digital media engagement can be difficult to manage, particularly if it goes viral. It requires immediate attention and a lot of skill to respond to it. As a public relations practitioner you will need to ensure that this is managed as it will have an impact on the image and identity of the organisation.
<ul style="list-style-type: none"> ● It is cost-effective because using online platforms to get the organisation's identity out there or maintain their image is not expensive. For example, doing online public relations campaigns, using Facebook pages and having Twitter accounts to disseminate information will not cost the organisation much. 	<ul style="list-style-type: none"> ● While cost is low, the management of digital media as a public relations tool is very high because it is extremely time-consuming.
<ul style="list-style-type: none"> ● Digital media is easily accessible for those with access to technology such as Internet connectivity, smartphones, etc. 	<ul style="list-style-type: none"> ● All stakeholders can comment widely on various digital media platforms about the organisation. It is as easy for negative messages to be disseminated as it is for positive messages.
<ul style="list-style-type: none"> ● The target audience can have constant on-demand information and data about the organisation. 	<ul style="list-style-type: none"> ● Inactive and unresponsive new media spaces mean that the organisation no longer has control of the information. It may mean that other people will start commenting on your organisation in this space and they will then have control over what is being said. It is very demanding to stay interactive and active within digital media spaces, and organisations need to consider this before embarking on a digital media strategy. 

Advantages	Disadvantages
<ul style="list-style-type: none"> ● Good use of digital media can build a brand and allow for constant messaging about the organisation's corporate identity. It can also assist with people's perception of the organisation and so contribute to a good corporate image. 	<ul style="list-style-type: none"> ● Digital media, if not managed and maintained properly, could negatively impact on the image of an organisation. If people post negative messages about your organisation and this is not managed, there will be a negative perception of your organisation in this very public space.
<ul style="list-style-type: none"> ● Owing to its mobility, digital media technology facilitates communication between various stakeholders, so you can connect with audiences with whom you may not have previously connected. 	<ul style="list-style-type: none"> ● There can be information overload, so your information always has to be focused.
<ul style="list-style-type: none"> ● Information can be gathered and distributed to the media much more quickly. 	<ul style="list-style-type: none"> ● Unwanted messages can have as fast a distribution as messages you want to be distributed.
<ul style="list-style-type: none"> ● It is more user-friendly and interactive. 	<ul style="list-style-type: none"> ● If the organisation's online spaces aren't user-friendly and interactive with easy navigation tools, people will not use this and find online spaces that work better for them in minutes.

Source: Adapted from Fielding & Du Plooy-Cilliers (2014: 324–325)

What exactly is the Internet?

The Business Dictionary (2014) defines the Internet as :

a means of connecting a computer to another computer anywhere in the world via dedicated routers and servers. When two computers are connected over the Internet they can send and receive all kinds of information such as text, graphics, voice, video and computer programs.

The Internet, once an almost surrealistic concept, has now become a business tool that could be one of the most useful communication devices used by the public relations practitioner.

The US Defence Force devised the Internet, which is often referred to as 'the global information superhighway', in the mid-1980s to act as a communication system for the exchange of scientific data and intelligence. The Business Dictionary (2014) explains that the Internet in this format was referred to as ARPANET (Advanced Research Projects Agency Network).

After the National Science Foundation Network joined the system and linked the Internet to universities and research bodies, it just grew and grew, and today it is accessible to everyone. No single person, organisation or country owns the Internet but various organisations are responsible for its functioning and running by designing structures to facilitate the process.

While the Internet is open-access and, therefore, people can post whatever they want, Internet users must be aware that they must obey the laws of the country in which they reside. If you are involved in illegal activities online such as child pornography or fraud there is a possibility that you will be traced and prosecuted.

The Internet is a wonderfully easy way to distribute information about a company, to issue media releases (with pictures, if desired) and to gather information or set up *online press rooms*.

What is on the Internet?

The Internet is vast. You can find almost everything you could ever wish to know or want on it. If what you are looking for exists, then the chances are that it will be stored somewhere on the Internet. However, information is not the only thing of use on the Internet. You can order or download almost anything you need through the Internet. You can, for example, download free software, order new hardware, or buy books, music, clothes, shoes, cars, houses and many other items. There are up-to-date news bulletins and weather charts, interviews to listen to, pictures to view or download, information about celebrities, etc. All you have to do is find it.

The Internet is just a physical connection. It is used as a global communication system using the following key tools:

- ▶ The world wide web
- ▶ E-mail

Online press rooms:
online repositories where organisations place information about their organisation that they would want journalists to access such as media releases, videos, biographies, etc

- ▶ Listservs or mailing lists
- ▶ Newsgroups
- ▶ Chat.

The World Wide Web (WWW)

According to Fielding and Du Plooy-Cilliers (2014: 322):

The World Wide Web is accessed via the Internet. It is a comprehensive information system that contains interlinked, hyperlinked documents, images and videos. Many people think the World Wide Web and the Internet are the same thing but they are not. The World Wide Web provides a standard procedure for people to access all the hyperlinked documents through the Internet. The Internet provides the infrastructure.

When looking up information on a certain topic, for example, you might have 3 000 references about that topic. Instead of downloading each article in its entirety, the search will give the first paragraph or so and refer you to a web address.

Most companies have their own web pages and addresses. This is an extremely important public relations tool. It is essential that an organisation's website is kept up to date, is user-friendly and easy to navigate. This is a public platform representing your organisation's corporate identity.

Searching the World Wide Web

One of the main reasons people use the Internet is to access information. Owing to the decentralised nature of the WWW and the enormous amount of information available, it can be very difficult to find the information that you are looking for. In January 2000, the WWW surpassed a billion web pages. Because of the vast number of web pages, finding specific information can be like finding the proverbial needle in a haystack. In order to locate information on the web, *search tools* are used. These perform searches of the Internet based on the input of the user and could include keywords, topics and phrases. Search tools are becoming more powerful and sophisticated every year and are indispensable because of the enormous amount of information out there.

Search tools

Search tools are divided into two main categories, namely search engines and categorised Internet Search Directories.

Search engines

Search engines search for information on the World Wide Web. You type keywords in to the search engine, which returns search pages. Examples of well-known search engines are:

- ▶ Google
- ▶ Lycos
- ▶ Yahoo
- ▶ AOL Search
- ▶ Bing
- ▶ YouTube (for video results only).

Popular South African search engines include Ananzi, Aardvark, Max and MWEB.



Exercise

Nielsen monitors and measures more than 90 per cent of global Internet activity and provides insights about the online universe – including audiences, advertising, video, e-commerce and consumer behaviour. Access the Nielsen homepage at <http://www.nielsen.com> and list the latest global search engine ratings.

There are probably thousands of search engines and directories on the WWW, most of them free to the user. They are able to provide a free service because they make their money through selling advertising or offering additional premium services.

Most search engines and search directories provide the following tools to help you find what you are looking for:

- ▶ a search form to enter your query
- ▶ ways to broaden or narrow the extent of your search
- ▶ a results list of pages that match your query.

The search engine usually produces a ranked list – the documents at the top of the list have more relevance than those towards the bottom. This is based on how many of the search terms are present in the document, how frequently the search terms occur and how close the search terms are to one another.

This section has online support material available.

E-mail: the abbreviated form of electronic mail, which is the transmission of messages over a communication network. Such messages can be notes entered straight from the computer keyboard or electronic files stored on a disk.

E-mail

E-mail is the tool that you, as a public relations practitioner, would use most frequently to get your company's news to the traditional media (Harrison nd).

Public relations practitioners used to provide either faxes or hard copies of a media release to inform the media about newsworthy events or developments. However, e-mail is faster and cheaper than fax and phone; in most cases, media outlets have made this accessible to submit media releases.

The advantages of e-mail is that the people you want to contact are able to receive mail seconds or minutes after it has been sent, and not days later. In addition you, as a public relations practitioner, can send the same media release and pictures to a host of different addresses at the same time. You can even ask for confirmation that the mail has been received by the parties to whom it was sent.

The e-mail system can be used internally, ie within an organisation, to distribute important notices, memos, newsletters, etc. Using e-mail in this way often alleviates the need to have frequent physical meetings in order to have memos, media releases and other articles cleared by superiors before they are released.

In companies with several branches scattered throughout the country, e-mail is a cost-effective communication tool.

Internet mailing lists

Internet mailing lists are mailing lists via e-mail that are set up between people who share interests. It is usually free to subscribe to such a list. You send a message to the list, and the message is sent to all of the other subscribers automatically. Another term for Internet mailing lists is 'listservs'. Examples of mailing lists are Listproc and Majordomo.

Media practitioners use these lists to come into contact with both expert sources and ordinary people who have information that they need. There are specialised mailing lists for journalism and public relations issues.



Exercise

Search the WWW and find a few mailing lists that interest you. Search the Web for the Institute of Public Relations and join their mailing list. As a future public relations practitioner, joining this list holds many benefits.

Newsgroups

Newsgroups are electronic bulletin boards on the Internet. Newsgroups can help communications practitioners to find specific people, identify expert sources and listen to conversations of interest groups.

This section has online support material available.

Deja is a popular newsgroup that allows users to search more than three years' worth of archives. Searches can be conducted by topic, author or e-mail address.



Exercise

Search the WWW and find at least 30 newsgroups that would interest you. Try to contact one. List the names of the newsgroups you chose.

Chat and instant messaging

Using chat rooms for more informal communication allows you to communicate worldwide with very little effort. Chat rooms enable you to link directly with anyone who is in the same chat room at the same time.

Instant messaging software and programs allow you to 'talk' to people in real time by typing and receiving messages. Instant messaging, or IM, is becoming increasingly popular for both personal and business use. These days, most IM programs can be accessed via the computer and smartphones. Advanced IM software also allows the use of rich media such as live voice and video calling, facilitated by the use of webcams.

Examples include the following:

- ▶ Mxit – popular South African chat software, most widely accessible via cellphones

- ▶ Twitter, Facebook and MySpace – social networking sites that have built-in IM chat software.
- ▶ Google, Yahoo and MSN – search engines that all have their own IM software that enables real-time conversations with the enhanced options of voice and video calling.

Online media

The online media landscape is ever-changing, with new technology being developed at an increasingly fast rate. In order to stay connected with their public, public relations practitioners need to keep abreast of changing technologies.

In the public relations profession, online communication is essential. Online public relations is more a matter of what people are doing with online media technologies than what these technologies are doing to people.

Websites, e-mail, intranets, Internet forums, wikis and blogs look different and act differently from the media of early mass communication such as newspapers, books, radio and television. Online media cover a broad range of communication systems, channels and formats. The Internet is the most important medium for online communication. All the elements of Internet communication technology are termed online media (Kelleher 2007).

The following is a set of definitions adapted from Kelleher (2007: 4–7):

- ▶ **Uniform resource locators (URLs):** The addresses at which you can locate Web resources. These resources can be in audio, visual and video form.
- ▶ **File transfer protocol (FTP):** A protocol that allows users to share files. A user uploads files to a server, and other users in different locations download these files using the FTP protocol.
- ▶ **Intranets:** These are internal networks over which users in an organisation share data. Intranets are secured, so that only employees of the organisation can access them.
- ▶ **Content management systems (CMS):** Systems that Internet users can use to collaborate on creating and managing content on the Internet. Wikipedia is an example of a CMS.

- ▶ **Wikis:** Website types that users can access and edit easily and efficiently.
- ▶ **Blogs:** Websites that users use to journalise more personal content about their lives or interests online. They are forms of interpersonal communication. A well-known example of blogging software is WordPress.
- ▶ **Feeds and really simple syndication (RSS):** Users subscribe to feeds and RSS. As content is added to these feeds, users are notified and receive the content. An example of a feed is the podcast, which users download to their digital media players.
- ▶ **Social networks:** Web-based interfaces that allow users to share their news and interests and to become informed about the news and interests of other individuals and organisations. There is no charge for using these networks, aside from the costs of the data you require to access them. They include IM services and e-mail. Examples are Facebook and Twitter.



The impact of digital or new media technology on the public relations profession

Digital media technologies allow for the multidirectional flow of information, targeting many people across different parts of the world. Earlier communication models placed emphasis on the sender of the information, but newer communication models stress the importance of the receiver. This shift in power means that public relations practitioners need to keep abreast of changing media technologies in order to stay connected with existing stakeholders and attract new stakeholders.

It is important to remember that digital media has not replaced the use of traditional media in public relations. Rather, it is important that public relations practitioners know when to use which mediums and which medium will be most effective at which point. Furthermore, traditional media and digital media must work hand in hand with public relations strategies, campaigns and plans. These should use both traditional media and digital media at all times. The principles of persuasion, credibility and communication do not change and one does not enter a world in which one must relearn everything. Many of the crafts that public relations practitioners learn in formal

and on-the-job training still apply online, but the emphasis is different enough to make one feel like a stranger in a foreign country (Bilbil & Sütçü nd).



Example

Using traditional and digital media in a blended public relations activity

You work for a chocolate manufacturer and one of your signature chocolates is called animal drops. Its logo is a rainbow-coloured ark filled with animals. You are planning to launch a new ark logo and have decided to take an unconventional route in launching this logo by running a competition.

You want an innovative public relations campaign for this launch and competition. So, you decided that, for a limited edition, you would package your animal drops with no logo and run a campaign titled 'Where did our ark sail to?'

In the traditional media, you will run advertisements in newspapers and magazines. There will also be a billboard campaign displaying the box without the animal ark logo on it.

The punchline for all the print media marketing will be: 'Discover where our ark has sailed – go to www.animaldrops/missingark.co.za.' This will drive traffic to your website.

On the website, the competitors will find clues to find the missing ark logo for the animal drops box.

They can choose to find the clues in two ways: by searching for them on the website or by following the Twitter handle @animaldrops.

The first 50 000 people who follow the clues and 'find the ark' will be sent a limited-edition hamper.

For the three months for which the campaign will run, all boxes of animal drops will be distributed with no ark on them. Once the campaign is over, the new animal ark logo will be launched on the boxes.

Digital media technology and public relations

One of the greater benefits of digital media technologies is its impact on research and evaluation in the field of public relations.

The advantages of, for example, online surveys are the following:

- ▶ access to internal and external participants
- ▶ the safe storage of results
- ▶ computerised analyses
- ▶ reduced cost
- ▶ real-time evaluation.

The online environment also enables easier management of:

- ▶ media lists
- ▶ distribution of media releases
- ▶ development and distribution of creative press kits (text, audio and video)
- ▶ advanced archive systems
- ▶ tracking of publicity: online groups, web traffic, polls, etc
- ▶ tracking of crisis situations: online updates, control room, enhanced communication with target publics, real-time FAQs through chat programmes
- ▶ geographically dispersed teams and online communities.

Summary

Digital media and online engagement has changed almost everything about the way the information needed by the media is found, processed and managed. Public relations practitioners affiliated to companies and government institutions can now refer journalists to their websites for the latest copy of a media release, a report or a study. Journalists locate interview sources, both people and data, on the Internet. Interview sources often prefer first contact by e-mail, not telephone.

For better or for worse, the Internet has changed the process of news gathering more profoundly and in a shorter period of time than any other development. As public relations practitioners we must be aware of this if we want to reach our target audience and build a bigger client base.

In professional and financial realms, those who do not have access to the latest in technological communication will find themselves at a distinct disadvantage.



Test yourself

1. Explain your understanding of the term digital media.
2. Discuss how public relations practitioners can apply digital media technology to improve their service.
3. Discuss a digital media tool you can use to make your company known worldwide.
4. Your organisation is celebrating its centenary and you need to gather information relevant to the organisation for publication in your yearbook. Explain how you can use the different facets of the Internet to assist you.
5. Explain what e-mail means. Also, discuss how the public relations practitioner can apply this tool effectively when dealing with the mass media.
6. Discuss how public relations practitioners can use social network sites such as Twitter and Facebook to gain favourable publicity.

Corporate social media



Objectives

After you have studied this chapter, you should be able to:

- understand social media as a public relations function
- discuss Web 2.0 and user-generated content
- discuss user-generated content published and social media
- describe the attributes of social media engagement
- identify popular social media networks that may be used for corporate social media.

Introduction

Social media refers to mobile and web-based technologies that are used to create interactive platforms where communities and individuals co-create, modify, discuss and share user-generated content (Kietzmann, Hermkens, McCarthy & Silvestre 2011: 241), such as Facebook, Twitter, YouTube, etc. We referred briefly to social media in Chapter 11.

As more people globally use social media to stay up to date, share news with family and friends and generally keep pace with what is happening within society, organisations are increasingly discovering the benefits of joining the conversation by utilising social media as part of their public relations, communication or media strategy. When using social media for business purposes, the term *corporate social media* (Postman 2009: vi, 3) is used. In order to maintain relationships with stakeholders and to attract support for business activities, organisations appoint social media teams or consultancies to

manage their corporate social media accounts. This chapter therefore introduces corporate social media as a public relations function and explains Web 2.0 as the technological driver of social media. In addition, this chapter describes the attributes of social media engagement while elaborating on popular social networks that may be used by the corporate social media team.

Social media as a public relations function



Take note

Before elaborating on social media, it is important to understand the difference between social media and social networks.

- **Social media** are mobile and web-based technologies that are used to create interactive platforms where communities and individuals co-create, modify, discuss and share user-generated content (Kietzmann *et al* 2011: 241). Social media is the umbrella term for all user-generated content that can be created and shared by anyone in the Web 2.0 environment, as will be explained later on in this chapter.
- **Social networks** are the platforms that people use on the Internet to belong to communities in which they share one another's interests. As a member of a social network, each person has a profile as well as some friends, followers or connections. Examples of social networks are Facebook, YouTube and Instagram. Social networks allow people to receive news updates from their social networks, to publish content and to engage with others.

Public relations practitioners increasingly rely on social media to generate publicity and to maintain relationships with stakeholders.

Characteristics of corporate social media as a public relations function

Social media strategy

Effective social media engagement requires the reliance on strategic plans that enhance business objectives. In other words, corporate social media engagement is a deliberate and planned process. In essence, a social media strategy outlines communication objectives to be achieved and identifies the most suitable social media platforms to engage with stakeholders. In addition, social media campaigns are usually planned around specific messages to create awareness or to change opinions about certain issues. Examples of social media campaigns are political parties during elections and brands when announcing new products or services. Further, social media campaigns are planned around special events

or fundraising efforts. As such, social media campaigns provide additional digital communication channels to support public relations, marketing and/or advertising campaigns.

Social media teams

The size and nature of the organisation will determine how many individuals are appointed in the *corporate social media team*. In many cases, organisations rely on *social media consultancies* to manage or to assist the social media team in the implementation of social media initiatives. An important consideration is the inclusion of functions across the organisation such as public relations, marketing, advertising and customer service. Considering that social media engagement is not exclusively a public relations function, strategies, social media messages and campaigns need to be integrated and co-ordinated across communication disciplines (Lieb, Owyang, Groopman & Silva 2012: 5, 18). The corporate social media team typically comprises job titles such as social media managers, brand journalists, community managers, online brand analysts and content managers.

Corporate social media team: all the individuals involved in managing the social media presence for a business

Social media consultancy: an agency that specialises in providing corporate social media services

Ensuring interesting and relevant content

The *corporate social media strategy* determines the most appropriate social media and social networks to use in order to achieve communication objectives. Considering the vast number of social media platforms where people constantly engage in conversations globally, the corporate social media team needs continuously to provide fresh content that is interesting and relevant to the needs of the various online audiences. For this reason, the social media team makes use of a content calendar (see Figure 12.1), also known as an editorial calendar (Groopman 2009: 172; Stokes 2011: 217; Solomon 2013: 9; Wilkins, 2013: 14).

Corporate social media strategy: a plan that determines the most appropriate social media and social networks to use in order to achieve communication objectives

A content calendar comprises of the communication themes and topics planned for the subsequent week or month as well as the multimedia content needed to spark conversations. In this manner, the corporate social media team is able to co-ordinate the sharing of interesting content across all their corporate social accounts on a regular basis. As such, an advantage of corporate social media is that public relations practitioners no longer have to rely on the mass media to reach their audiences. Public relations practitioners can engage directly in conversations with



their stakeholders and publish their own media content.

Content calendar for a community gym

Weekly theme/ message	Social media platform	Monday 01 Feb	Tuesday 02 Feb	Wednesday 03 Feb	Thursday 04 Feb	Friday 05 Feb	Saturday 06 Feb	Sunday 07 Feb
Stay healthy, stay slim	Facebook	Status update: Come and get a free fitness assessment at your nearest gym.	Status update: Not sure where to find your nearest gym? Use this handy map. Supporting content: Google map with gyms, contact details and websites indicated			Status update: Get inspired to eat healthily with our inspirational and free recipe book. Supporting content: Hyperlink to colourful PDF recipe book available from the gym's website		
	Twitter			Tweet: Look good when going to the beach this summer. Join our gym now. Tweet: Five tips for a complete workout Supporting content: Hyperlink to a YouTube video Tweet: Beat office stress and join our early-morning spinning classes with fitness expert Joe Soap. Supporting content: Hyperlink to incorporate blog written by Joe Soap				



Weekly theme/ message	Social media platform	Monday 01 Feb	Tuesday 02 Feb	Wednesday 03 Feb	Thursday 04 Feb	Friday 05 Feb	Saturday 06 Feb	Sunday 07 Feb
	Google				Status update: Join our kickboxing classes for a beautiful bikini body. Choose a class that suits your busy schedule. Supporting content: Hyperlink to corporate website class schedule			
	Corporate blog	Fitness expert Joe Soap explains how early-morning spinning classes help to combat office stress.						
	YouTube		Two-minute video featuring five tips for a complete workout					
	LinkedIn							
	Pinterest							
	Instagram							

Figure 12.1 A content calendar used by the social media team

Online monitoring

Continuous conversations occur on social media platforms such as Facebook and Twitter. Many of these praise an organisation and many criticise an organisation. In short, what is described here is an organisation's digital footprint, which is the sum of all content related to an organisation that is available online. If the social media team does not track social media conversations in real time, they miss out on the opportunity to rectify incorrect perceptions or to reinforce positive opinions. Ignoring social conversations or only responding a day or two later is a sure way to lose credibility online.

In the same manner, efforts by the corporate social media team to control what people say online is another way to lose stakeholders' trust and respect. Therefore, the social media team needs to monitor social media platforms constantly and respond quickly (Lawton Communications Group 2013: 9; Stokes 2011: 414). Inaccurate information needs to be tactfully rectified and aggressive responses should be avoided at all times. Remember, social media conversations assist the public relations practitioner with valuable insights into public opinion in real time. Moreover, social media conversations help the corporate social media team to identify trends and to manage an organisation's reputation. As such, the social media team needs to compile reports to management regularly in which corporate social media efforts are measured, evaluated and analysed.

Engaging journalists

Many professional journalists effectively use social media when collecting facts for their stories. This provides public relations practitioners with an opportunity to establish favourable media relations by distributing newsworthy facts across corporate social media accounts. Most importantly, the corporate social media team acts as the spokesperson for the organisation. As such, journalists may quote whatever is said on corporate social media accounts as an official comment.

Keep in mind that journalists also rely on social media to source eyewitness accounts for news reports. Therefore, it is necessary for the social media team to monitor social media constantly in order to be aware of the kind of stories that

interest journalists and to provide suitable information when necessary. Moreover, as people publish details about an event that has just occurred, social media may reveal breaking news in real time, which the journalist can investigate further.

Journalists also use social media to report on events as they unfold, especially on social networks such as Twitter. During the Oscar Pistorius murder trial in 2014, for example, journalists not only relied on traditional media but on social media as well to update audiences constantly about events. Similarly, millions of people around the world relied on social media to follow journalists' updates about former president Nelson Mandela's death and funeral in December 2013.

Web 2.0 as the technological driver of social media

Internet technology that makes it possible for anybody to create and publish digital media easily is called Web 2.0 (Kaplan & Haenlein 2010: 61). Digital media is any computerised media and is stored on computers using different computer programs that can create and open these media files. The digital media file formats are visible as file name extensions when viewing a file directory, such as .pdf, .mp3 or .jpeg. It is necessary to understand the formats of digital media files when using the Internet to upload or download digital media such as music, photos or videos.

Table 12.1 Various digital media and their digital media file types

Digital medium	Digital media file name
Images such as photographs	JPEG: Joint Photographic Experts Group TIFF: Tagged Image File Format
Documents containing text and/or images	PDF: Portable Document Format
Videos	AVI: Audio Video Interleaved WMV: Windows Media Video MOV: QuickTime Movie File WMV: Windows Media File MPEG: Moving Picture Experts Group MP4: MPEG-4 Part 14
Audio recordings such as music	MP3: MPEG layer 3 audio file WAV: Waveform

Digital medium	Digital media file name
Digital pages that display graphics, fonts, colour and hyperlinks typically found on the World Wide Web	HTML: Hypertext Markup Language

It is necessary to discuss how Web 2.0 makes it possible for anybody to create and publish content. In the past, Internet technology was called Web 1.0, and comprised static web pages that could only be created by people with expert computer programming skills. In contrast, Web 2.0 is also known as the participative web or the people-centric web, on which it is easy for anyone to publish content and engage with others (Raffl 2008: 86). The term Web 2.0 was recognised for the first time in 2004.

User-generated content and social media

When people use Web 2.0 platforms to share digital media that they have created themselves voluntarily and for which they generally receive no payments, they create what is known as user-generated content. Examples of user-generated content may be a cellphone video of you playing the guitar that you edit and publish on a social networking site such as YouTube; or when you go to a restaurant, take a photo of your food and post it on Facebook together with a recommendation to your friends to eat at that restaurant. Another example of user-generated content is when you post a comment about a movie or television programme on a social network in which you criticise the storyline and tell your friends to avoid the movie or television programme. When posting your comments about a brand, an online equivalent of word-of-mouth, called word-of-mouse, occurs on a social network.

User-generated content can be found on various types of Web 2.0 platforms (OECD 2007: 16) and are often shared with others as social media. A description of the various types of Web 2.0 platforms for sharing user-generated content is given in Table 12.2.

Table 12.2 Types of Web 2.0 platforms for sharing user-generated content

Web 2.0 platforms	Description	Examples
Social networking sites	Websites on which one joins an online community. A member is able to create a profile that usually consists of a photograph and a short biography. A social networking site allows members to befriend others and communicate with them.	Twitter, Facebook, LinkedIn, YouTube, Flickr, Instagram
Group-based aggregation	People collaborate to aggregate content by rating or tagging content. Content aggregation occurs when you find somebody else's content, which you re-share, rate or tag. Tagging is a way to add digital labels to the vast amount of information available online. You simply add a word or phrase of your choice to content such as images, text or video. Tagging is helpful to categorise information and to help others to find all available content related to a particular tag. Some websites – blogs in particular – visually display a collection of tagged content as tag clouds.	Rating content on Reddit and Digg. Tagging bookmarks on Pinterest and social bookmarking sites such as Delicious and StumbleUpon. Tagging content on YouTube, Flickr
Blogs	Personal websites on which writers share personal experiences, opinions and multimedia. A blog is regularly updated and allows readers to leave their comments. Many blogs read like personal diaries.	WordPress, Google Blogger, Tumblr, Typepad
Wikis	Websites on which many people work together collaboratively to add content or to edit one another's contributions.	Wikipedia, DokuWiki, WikkaWiki, Wikia
Podcasting	Podcasting allows anyone to create and publish audio or video content. Popular podcasts are Internet versions of traditional television and radio programmes. You can search for a podcast topic that you are interested in. Thereafter you can download the podcast to a computer or mobile device to watch and listen whenever you want.	iTunes, iPodder, Podcast Pickle , Podcast Alley

Web 2.0 platforms	Description	Examples
Virtual worlds	Digital spaces that look like real-life environments. People can interact with each other and with virtual objects. Generally, people are represented by animated characters called avatars (Bainbridge 2007: 472). People often create and trade objects that they have created in virtual worlds.	Farmville, World of Warcraft, Twinity, Entropia Universe

The attributes of social media engagement

Social media have unique attributes that describe the norms and expectations of online interactions. Correspondingly, these attributes highlight how social media differ from traditional media. Effective corporate social media engagement requires the public relations practitioner to understand the following attributes:

- Conversations:** In essence, social media technologies are designed to make it easy for people to engage in two-way conversations with one another (Kietzmann *et al* 2011: 244). The fact that peer-to-peer, interactive and simultaneous conversations continuously take place in real time is the most significant difference between social media and traditional media such as newspapers, radio and television. As anyone is able to be a publisher, social media has democratised the media by giving a voice to everyone, not just those with the resources to reach audiences via traditional mass media.

In order to categorise content, a hashtag symbol is commonly used before a chosen phrase or word. Using hashtags is a specific way to tag content. When a word is hashtagged, it makes it easy for social media users to search for all the related status updates, tweets, images or videos. Since millions of people engage in conversations about a chosen topic, social media has the collective power to influence the news agenda and public opinion. When many people engage about a topic and share content across their social networks, it is indicated as a trending topic. Similarly, when many people share content with one another it is said that a tweet, a status update, a video or an image goes viral in the same way as a medical virus spreads from person to

person. An example of a viral video is artist Psy's music video '*Gangnam Style*'. A good example of a hashtagged trending topic that went viral is #BringBackOurGirls, related to the kidnapping of 200 schoolgirls in Nigeria by the militant group Boko Haram on 14 April 2014.

► **Connectivity:** People around the world are connected to one another in communication networks via social media platforms on which they share content such as text, visuals, audio and hyperlinks (Kietzmann *et al* 2011: 245). A major driver of social media is the human need to belong to a social group where they can stay in contact with others, make new friends and share life's ups and downs. In social networks, people's connections are visible as a certain number of friends or followers.

It is generally believed that a large number of friends or followers is indicative of a person's online popularity or social influence. A social media influencer is the social media equivalent of an opinion leader who has the potential to influence the viewpoints and behaviour of others. Interestingly, people trust the opinions of their friends on social networks instead of the opinions expressed by professionals such as advertisers, journalists or public relations practitioners.

► **Transparency:** People are free to reveal any information with others. People's lives are increasingly becoming public information as individuals share their life stories, opinions and observations (Gibbon & Hawkes 2008: 3). Given the free flow of unedited information, there is almost no direct control over the kinds of opinions being expressed on social media. As a result of the open nature of social media, it is becoming increasingly difficult for those in power, such as organisations and public figures, to hide embarrassing facts, wrongdoing and other secrets. At the same time, it is expected that people are transparent about their true identities and intentions on social media. Social media profiles of people who are deliberately deceptive by pretending to be someone else or by hiding their true identities are regarded as unethical. These deceptive identities are usually quickly discovered and exposed by one of the millions of people who are active on social media around the world, seven days a week.

'Gangnam Style' was released on 15 July 2012. On 21 December 2012 it became the first YouTube video to reach a billion views (Farberov 2014). By 31 May 2014 it had been viewed over two billion times, making it YouTube's most watched video.

- ▶ **Authenticity:** Although social media is shared digitally, people expect to engage with real people who share their real opinions as humans in a fairly intimate manner (Postman 2009: 8). Moreover, the intention of social media is to enjoy a digital space where people can socialise with friends in the same tone and manner as they use for face-to-face conversations. When engaging with organisations and brands, especially, people expect engagements to be truthful and authentic as opposed to overly formal. When engaging in dialogue, highly formal business jargon and overly obvious promotional content, which are appropriate for commercial channels such as advertisements, are regarded as inauthentic in social media. Good examples of authentic voices may be found on the blogs called 'Diary of a Zulu Girl' and '2summers'.
- ▶ **Collaboration:** Social media technologies provide platforms on which people may come together and co-create in online communities that share a common purpose (Gibbon & Hawkes 2008: 3). Co-creation occurs in connected networks when knowledge, content, skills and suggestions are being exchanged (MGI 2012: 10). As such, collaboration occurs when people contribute co-operatively in a digital community.

The collaborative potential of social media to bring about change was illustrated when thousands of people relied on social media to organise protests in the Arab world in 2011, called the Arab Spring. The collaborative potential of social media to organise humanitarian efforts and to raise money for those in need was evident during the Haiti earthquake in 2010 and the tsunami in Japan in 2011.

Popular social media networks

For many people, social media has become the preferred way to stay in contact with one another and to interact with businesses, celebrities and almost any other organisation imaginable. Mobile devices, such as cellphones and tablets, are the most preferred way to access the Internet in South Africa and sub-Saharan Africa (TNS 2012: 3). As such, social networks are available as applications that can be downloaded to your mobile device for quick and easy access. Recent statistics confirm that social media adoption in Africa is increasingly gaining momentum as it catches up with the developed world (TNS 2012: 4; World Wide Worx & Fuseware 2013: 1).

The ranking of the most popular social networks fluctuates constantly as new platforms quickly gain popularity while older, more familiar platforms lose their appeal. It is also interesting to note that the ranking of the most popular social networks varies from one region to another as each seem to have their own favourites. To illustrate, for many years Mxit was more popular than Facebook in South Africa. It was only in 2013, when Facebook became the most popular social network in South Africa, that Facebook gained more users than Mxit for the first time (World Wide Worx & Fuseware 2013).

The user numbers of social networks change rather quickly. For this reason, an overview of social networks that are popular both internationally and in South Africa is given briefly below. To gain a true understanding of these social networks, it is a good idea to maintain an account. In most instances, all you need is an e-mail address and to provide basic personal details in order to open a social network account at no cost. Most social networks allow businesses to pay a fee to place advertisements for their goods and services. However, if a business uses a social network account to engage with others, it is available for free in the same way as individuals use social networking accounts. Depending on the nature of the business and the audiences that are targeted, the corporate social media team may maintain active accounts in various social networks. Popular social networks include the following:

- ▶ **Facebook:** Once you have opened an account, you may post status updates and share multimedia content and hyperlinks that become visible in friends' newsfeeds. You may also join groups of like-minded individuals who have shared interests. If you do not want to be Facebook friends with someone, you can also choose to follow a person, which means that their status updates appear in your newsfeed. If you are interested in receiving status updates from a brand page, you can 'like' the page.

For corporate social media purposes, the social media team is responsible for providing interesting multimedia content on an organisation's Facebook page. Facebook not only keeps stakeholders updated on the latest news about an organisation, but also provides a valuable source for journalists' stories.

► **LinkedIn:** Using LinkedIn, people network with one another as professionals by publishing their career experience and skills. This information serves as an online CV. LinkedIn is used to notify others of job opportunities or to find individuals who match a particular job description. You can follow organisations, influencers or join various professional groups where members exchange ideas and their expertise related to the world of work. For corporate social media purposes, LinkedIn is used to share career-related content that a particular industry finds useful. LinkedIn may also be used by journalists to source information for stories.

► **YouTube:** YouTube is a video-sharing social network. A YouTube account is known as a YouTube channel. Videos are uploaded and shared with others. Social interaction occurs by subscribing to channels, befriending others and commenting on videos. People may also opt to respond to other channels by posting response videos.

For corporate social media purposes, YouTube channels can be described as an organisation's own television station. Professionally edited videos about newsworthy topics may reach millions of people around the globe.

► **Pinterest:** Pinterest is known as an image-based social network. People bookmark, upload and share their favourite images and videos of their interests and hobbies. When pinning images, users group them together according to a chosen theme on virtual pinboards. Every board is then given a name, such as 'weddings', 'my favourite shoes' or 'musicians'. Social options include following other pinners and posting comments.

Corporate social media teams rely on Pinterest to showcase their goods and services by sharing visually appealing images. Pinterest may be used by journalists when they are sourcing images to accompany news reports.

► **Twitter:** Twitter is a microblogging site on which short messages, called tweets, are limited to 140 characters. A Twitter account is typically recognised by a profile name, called a handle, which is indicated by an @ sign preceding the username. Once an account is created, people interact with one another and follow other users in order for tweets to be received in a news stream called a timeline.

- ▶ The re-sharing of other people's tweets is called a retweet. Tweets are public and can be read by anyone. Private tweets, called direct messages, are exchanged between people who follow one another and are only visible between two people. Twitter is popular as a platform where controversial topics are being discussed and where breaking news is instantly tweeted by journalists and ordinary people alike. Tweets not only contain text, but may also include hyperlinks, photos and videos.

Corporate social media accounts on Twitter are used to share newsworthy content, especially breaking news. Twitter is also used to engage with journalists. Twitter is a popular source of information for journalists when they are sourcing information for news reports.

- ▶ **Google+:** Pronounced 'Google Plus', this social network allows you to follow others who can be grouped together in circles. Each circle is then given a name of your choice, such as 'celebrities', 'university friends' or 'family'. The names of your circles are visible to you only while other Google+ users will be notified when they are added in one of your circles. When posting content in Google+ such as text, hyperlink, photos or videos, you may choose which of your circles may view your post. Social options include joining specific communities of interest and commenting on others' posts. Moreover, hangouts allow users to text chat or video chat with others.

The corporate social media team may use Google+ to conduct hangouts with stakeholders, which then act as virtual special events, virtual conferences or virtual tours. In addition to managing a Google+ page, the social team may also share relevant content in Google+ communities. Google+ may be used by journalists who are sourcing content for news reports.

- ▶ **Instagram:** Instagram is known as a photo taking, editing and sharing social network. Once you have taken a photo, you can choose from several photo filters and creative effects that may transform ordinary photos into professionally edited images. When posting photos, these are accompanied by short captions, usually in the form of hashtagged words and phrases. Similarly, short video clips (limited to 15 seconds) are uploaded, edited and shared.

Social options include posting comments and choosing whom to follow. Instagram is mainly used on mobile devices. The corporate social media team may use Instagram to share creative photos and short videos that followers may find interesting or amusing. Instagram may be used by journalists when they are sourcing images or video snippets to accompany news reports.

- ▶ **Flickr:** Popular among both professional and amateur photographers, Flickr is a photo-sharing social network. Photos taken with digital cameras or other mobile devices are uploaded and grouped into albums. In addition, short captions are added and photos are tagged. Flickr applications provide photo-editing filters to enhance an image. In the same manner, videos of no longer than 30 seconds are uploaded and edited. People can also comment on one another's photos.

The corporate social media team may use Flickr to share professionally captured and edited photos with followers. Flickr may be used by journalists when they are sourcing images to accompany news reports.

Summary

Corporate social media engagement is a planned and deliberate process that supports public relations strategies, marketing strategies and advertising strategies. Having an understanding of how people create and share user-generated content enables the corporate social media team to implement initiatives that appeal to organisational stakeholders. Lastly, social media teams need social networking skills in order to select the most appropriate platforms to reach organisational stakeholders and to share content that audiences find interesting and relevant to their needs.



Test yourself

1. Explain the difference between social media and social networks.
2. Discuss the purpose of drawing up a social media content calendar and draw up a calendar about an event in your organisation using the example in Figure 12.1.
3. Describe five types of Web 2.0 platforms on which user-generated content is shared, and give examples of each.
4. Discuss five attributes of social media engagement.
5. Identify five popular social networks and explain how you as public relations practitioner would use each one for your organisation.

How to use the various media



Objectives

After you have completed this chapter, you should be able to:

- analyse various newsworthy events in an organisation
- choose the most suitable media for these events.

Introduction

In this book so far, you have been given a general idea of how newspapers, magazines, television, radio and social media function. Besides the fact that knowledge of these various media is imperative, the public relations practitioner should be able to analyse an event and decide which medium or media will publicise it most suitably.

Practical exercises

To assist you in the decision-making process, this chapter presents several scenarios. Analyse each one and, keeping in mind the types of media and their particular requirements, indicate the most appropriate medium for each scenario. Do not forget, however, that more than one medium might be suitable for some scenarios. In the case of the electronic media, indicate the category and then motivate your choice of media and category (where applicable).

Acquaint yourself with the various newspapers, magazines, radio services and programmes available in your area (suggested in the previous chapters). Familiarise yourself with the television programmes and categories available to you. Furthermore, you will need to keep up to date with technology and ensure that you understand the various and most effective new media platforms, tools or applications available to you as a public relations practitioner. By doing this, you will be able to give exact details when choosing media.



Take note

For each scenario, you must place yourself in the position of the organisation's public relations practitioner. These scenarios are possible newsworthy organisational happenings or events.

Scenario 1

You work for a large platinum mine. This week, your organisation has had two major crises. All of the mineworkers have gone on strike and two of the mineworkers have been killed in violent clashes.

Choice of medium/media: _____

Category (if applicable): _____

Motivation: _____

Scenario 2

You are the public relations practitioner for a well-known sports personality. It has just been announced that he is up for an international sporting award to be presented in Los Angeles next month. He is the first South African sporting hero ever to achieve this status. You will need to inform the public and ensure that there is sufficient publicity prior to him leaving for the event in Los Angeles.

Choice of medium/media: _____

Category (if applicable): _____

Motivation: _____

Scenario 3

You work for a beverage company that has just been bought by another beverage company. Your company will be going through a merger. A change in corporate image and identity is planned.

Choice of medium/media: _____

Category (if applicable): _____

Motivation: _____

Scenario 4

You are the town municipality's public relations practitioner. The town is celebrating its centenary. Various events have been organised. They include:

- the opening of the new town hall by the mayor of the town
- a mass song and dance extravaganza involving 100 surrounding schools
- a flea market at the local sports grounds.

Choice of medium/media: _____

Category (if applicable): _____

Motivation: _____



General exercise

In the following exercise, a list of news events is provided. Choose news events that you consider appropriate for the following media:

- the local newspaper
- a national newspaper
- national and/or regional radio news bulletins
- television news
- the company website
- social media platforms/applications/tools.

1. A section of one of your building sites collapses, killing 10 employees and injuring 32.

Media: _____

2. An organisational open-day for which various activities for young and old have been arranged.

Media: _____

3. The launch of your new company logo is happening within the next six months; you need to create hype and awareness.

Media: _____

4. Fraud involving millions of rand by the CEO of your organisation.

Media: _____

5. Your organisation is participating in a community project by painting three underprivileged schools in the surrounding area.

Media: _____

6. You work for ABC Bank. There have been armed robberies at five of your branches. Three branch managers have been killed in these attacks and two have been wounded. In addition to the tragic deaths, your bank has lost a large amount of money in all of these robberies.

Media: _____

7. You are launching a campaign to create public awareness about child abuse on a national level.

Media: _____



Exercise

Creative thinking: A news-breaking story may lead to another angle of the story or even an in-depth article on the story. Consider the list of events given in the general exercise. Think of articles that could be written about these events in magazines, eg a miraculous recovery by a victim involved in the collapse at the construction site.



Example

Case study: Kariega Game Reserve rhino poaching – use of traditional and digital media

As the only survivor, her story of sheer determination and will to survive represents hope in the face of hopelessness. This story stands as testimony to the worst and the best of human attitudes towards animals. Dr William Fowlds, Investec Rhino Lifeline and Wildlife Veterinarian

On 2 March 2012, rangers on patrol at Kariega Game Reserve in the Eastern Cape found three rhinos, their horns hacked off by poachers. The older bull, No. 84, had died and the young bull and cow were still alive. Themba (isiXhosa for Hope), the young bull, died on 25 March 2012. Thandi (isiXhosa for Nurturing Love), the cow, survived, beating the odds. Her remarkable recovery has made her the beacon of hope for her species, even more so with the latest announcement that Thandi is pregnant.

Kariega Game Reserve implemented an open-content strategy after this sad event. They did not want to own the content (video, imagery and copy) and encouraged it to be distributed freely by the traditional and digital media. Alan Weyer, GM of Kariega Game Reserve, said:

When we discovered our poached rhino, the owners of Kariega Game Reserve took a conscious decision to publicise the events as they unfolded as much as possible to create awareness of the terrible brutality of rhino poaching.

The event was picked up and followed around the world on both traditional and digital media – not only creating awareness about what was happening to rhinos in Africa, but mobilising individuals to respond in their own way to support the Kariega Save the Rhino Project.

Shortly after the poaching incident in March 2012, the Kariega Game Reserve, through the Kariega Foundation, established a Save the Rhino Fund. Many other initiatives were set up to raise funds for Thandi and rhinos in general. These include the Rhino



Run, a South African trail run held on World Rhino Day, and the Rooting-for-Rhino Challenge – a Facebook site encouraging schools to form, photograph and upload their own human rhino images, uniting against rhino poaching.

Many organisations supported the Kariega Fund, including the Chipembere Rhino Foundation. The initiatives by individuals, schools, organisations, etc, enjoyed widespread publicity in traditional and digital media.

The initial news of the poaching and the subsequent updates on Kariega’s website and social platforms were shared by users, and the content and story went viral.

The Kariega team – together with Dr William Fowlds, well-known wildlife veterinarian who was called to the scene on 2 March 2012 to attend to the wounded rhino – issued daily blogs and updates on Kariega’s website, Facebook and Twitter with supporting video on YouTube to share the treatment progress and ups and downs for an increasing number of followers. Kariega’s website reached a record number of users during March 2012.

When Themba, the young bull, finally lost his fight for life on 25 March 2012, the Kariega team posted the following on their Facebook page:



[Kariega Game Reserve](#)

[March 25, 2012](#)

UPDATE SUNDAY 25 MARCH 2012 11H00

It is with a huge sense of grief that we regret to inform you of the passing of Themba this Sunday morning. In his compromised state he failed to remove himself from a waterhole he had been drinking at. In spite of efforts to assist him he passed away just after 9 a.m.

Like 95

Comment 357

Share 195

The news of Themba’s passing was also carried in local and international traditional media and messages of condolences streamed in, mostly onto the Kariega Facebook page.

The Kariega social media audiences continued to grow as Thandi’s remarkable story unfolded. These peaked during key events such as her numerous check-up procedures, including becoming the first rhino to receive a skin graft and the news that she was awaiting the birth of her baby rhino. The Kariega team continued to update their website and social media platforms with Thandi’s activities on the reserve as well as coverage of Thandi in local and international newspapers and magazines, radio and television stations. The announcement of her pregnancy gained much publicity locally and worldwide in traditional and digital media.



Thandi's story has been published in local and international newspapers, magazines and websites, aired on major television and radio networks and used in anti-poaching campaigns, giving the rhino poaching crisis and Kariega major exposure. A list of media has been collated from these activities and Kariega continues to communicate relevant updates via e-mail.

Kariega now uses sophisticated digital software to track and manage its large and active audiences, including those on its website and blog (www.kariega.co.za); its more than 10 000 fans on Facebook (www.facebook.com/kariega.game.reserve); its 2 300 Twitter followers (www.twitter.com/kariegagameres); and growing numbers on YouTube (www.youtube.com/KariegaGameReserve), Google+ (<https://plus.google.com/+KariegaCoZa>) and Instagram (www.instagram.com/kariega.game.reserve).

Kariega continues to encourage everyone to share Thandi's ongoing story. Kariega owner Graeme Rushmere comments:

We continue to be inspired by Thandi's incredible fighting spirit and miraculous recovery. We are buoyed by her pregnancy and look forward to welcoming her calf towards the end of 2014. We would like to thank all those who have supported Kariega Game Reserve and our rhinos. We continue to be overwhelmed by your generosity.

See more at: <http://www.kariega.co.za/blog/categories/thandi-and-themba>

Information as supplied by:

Bronwen d'Oliveira

Digital Communication Specialist

Kariega Game Reserve

Eastern Cape



Take note

This case study is an example of an integrated approach to media use in a public relations campaign. Both traditional and digital media played a role in communicating the message from the organisation to the public as well as from the public back into the organisation.

While the public relations mileage was high, much of it was a result of the social media attention the event created. It is evident from this case study that traditional media played a role on both a local and international level to create awareness of the plight of the rhino. This traditional media was coupled with the use of digital media both from the organisation and the public because the media exposure then created individual interest, which was converted to followers via social media platforms to support this cause. Not only has this incident focused attention on rhino poaching and the devastating consequences thereof, but Kariega Game Reserve has earned much mileage and positive publicity.

Traditional media is not going away, but it can no longer stand alone as a media strategy for a public relations campaign. It needs to be integrated with an online media strategy. In other words, all public relations strategies need to include both traditional and digital media in getting their message across. Using only one style of medium is not sufficient to get your message across in this global environment with multiple communication touchpoints.

If you are not aware of the existence of a place like Kariega Game Reserve in the Eastern Cape, you will not go to their website or Facebook page or follow their Twitter handle unless you accidentally come across it in your search for a safari holiday. The best way to get known out there is to have an integrated public relations strategy that blends online and offline *communication touchpoints* and deals with stakeholders via varied means, such as personal encounters, varied customer service techniques, various marketing techniques, mediated communication touchpoints via traditional media campaigns and mediated touchpoints via social media.

Communication touchpoint: in this context, this refers to the different ways and mediums that an organisation can use to reach stakeholders. It describes the points of contact and interaction online and offline that your organisation will have with stakeholders. This includes any and all interaction, ie face to face or mediated.



Example

First release of video footage – Kariega rhinos,

Monday 12 March 2012



—We are releasing the first of several videos taken by the team on the ground, starting with this one taken at KARIEGA GAME RESERVE on Friday 2 March 2012. Although this footage is quite shocking, we believe that the unbelievable courage shown in the fight for survival of our two rhinos, Themba and Thandi, must be shown to the world! Furthermore, we will be shortly releasing a video message made by our ranger team on the ground titled UNITED WE STAND, showing their utter horror for this scourge plaguing our country, and how extremely dedicated they all are to the continued survival of Thandi and Themba!

Published on 12 March 2012: www.facebook.com/kariegagamereserve



Figure 13.1 Video release of rhino poaching at Kariega on 12 March

www.youtube.com/watch?v=lAbqai-PSW4 (not for sensitive viewers)



Figure 13.2 Thandi – one of the pictures released on 12 March 2012 (Instagram)

<http://www.wildlifeextra.com/go/news/thandi-kariega.html#cr>



Extracts from the Kariega Team and Dr Fowlds's daily blog

Rhino poaching: Day 2 – 16h30

Posted on Kariega website and Facebook on 3 March 2012. Filed in Thandi and Themba.

Male rhino leg swelling has deteriorated and he is not using it at all now. We have administered antibiotics and more anti-inflammatories using drop out darts this morning. He is not eating or drinking yet. The female was not found this morning after a morning of searching on foot. A helicopter was offered by Warne Rippon to assist with an aerial search but she has still not been seen today. Temperature on the ground is over 35 degrees C so we suspect she is lying up under thicket canopy. Not being able to confirm her status is a concern and the search continues.

Will Fowlds

– See more at: <http://www.kariega.co.za/blog/rhino-poaching-day-2>

Rhino poaching: Day 3 – 17h00

Posted on Kariega website and Facebook on 4 March 2012. Filed in Thandi and Themba.

Kariega male survivor appears to be in a lot of pain this afternoon. He has moved off to a position where the terrain makes safe top-up treatment very risky. Hoping he will keep moving away from this area this evening so we can administer more drugs. His leg swelling appears to be deteriorating, which is not good news. The female has not been seen today but we plan on doing a scheduled procedure in the morning to evaluate and treat her.

Will Fowlds

– See more at: <http://www.kariega.co.za/blog/rhino-poaching-day-3>

Rhino Themba's passing: Day 25

Posted on Kariega website and Facebook on 26 March 2012. Filed in Thandi and Themba.

Themba's passing has been desperately tragic and I know that everyone at Kariega is hurting badly having been so intimately involved in his personal struggle to survive. Having deliberated so much about putting him to sleep the day before, his inability to get himself out of the waterhole was a clear indication that he had grown too weak to manage even the simple things he was used to doing.



We buried him where he lay and as the ground proudly accepted him back, he took with him the tension that had become a part of that beautiful valley for the past 24 days.

This ordeal he has endured, set in motion by the senseless greed of men who know nothing of their suffering and probably don't care, this fight which has revealed to us a will to survive beyond our previous comprehension, this tragedy which has captured the hearts of so many; what will his story teach us? What will Themba's legacy be?

Will Fowlds

– See more at: <http://www.kariega.co.za/blog/rhino-thembas-passing-day-25>

Rhino Thandi: Day 33

Posted on Kariega website and Facebook on 3 April 2012. Filed in Thandi and Themba.

Today is day 33. The last time we worked on Thandi was 23 days ago and I was very apprehensive about what we might find under the gruesome exterior of her facial injuries. The Kariega team for today's procedure consisted of 25 individuals on site but with so many thousands willing her to get well and anxious for news of her progress, we feel like only one small component of this rhino's support network. Thandi's Team.

Every time we work with her face I am both appalled by the extent of her wounds and encouraged by the determination that this body possesses to recover. In spite of the destruction of her face to such a degree that 33 days later she still has a mutilated crater that is 37 cm long and 19 cm wide. Regardless of the long hours she spent struggling on her side, in shock and agony, she is determined to survive. Under the constant threat of complications from maggots, infection and rotting bone fragments, Thandi has made her choice – this girl wants to live and she wants to live well. In spite of everything she has gone through, this living, breathing, feeling animal just keeps marching down her road towards recovery.

What an inspiration, this one rhino called Thandiswa, is proving to be. What a beacon of hope she is providing for us when there are so many horrendous stories and statistics drawing dark clouds over the future of this species. What an example of how we need to FACE UP to the realities of poaching, stop talking and start doing.

Thandi, you are a true champion of the cause. You are beautiful.

Will Fowlds

– See more at: <http://www.kariega.co.za/blog/rhino-thandi-day-33>



Rhino Thandi: Day 53

Posted on Kariega website and Facebook on 23 April 2012. Filed in Thandi and Themba.

After several unsuccessful attempts during the preceding week to get a close-up assessment of Thandi, things finally worked in our favour. And, girl, did she give us more than we bargained for.

With my levels of concern escalating after nine days without a personal visual assessment of her injuries, and with the prospects of another 10 days away lying ahead of me, I felt quite anxious to put my own mind at rest that she was indeed doing OK. I really prayed that she would give us the glimpse I needed to be able to go away at peace in the knowledge that she was not under increasing levels of pain, that the maggots had not got a foothold somewhere, and that there wasn't an area of infection contaminating the healing tissues around it. This was my last chance for a little while and so we had to push the boundaries a little further than I was comfortable with.

Today is day 53. Yet again, many people will come together at that place of such contrasting emotions, bringing together a diverse collection of skills but with only one focused goal in mind. To help take Thandi, ALIVE, through her next surgical procedure. We come together apprehensive as we always are, but inspired by so many of you in this world who share our common purpose in supporting her through her healing process. You have expressed this in so many ways from donations to words of encouragement towards the privileged few who will tend to her needs. Thandi lives, to tell her story, only by the way we are able to tell her story for her.

Will Fowlds

– See more at: <http://www.kariega.co.za/blog/rhino-thandi-day-53>

Media headlines following rhino poaching at Kariega Game Reserve on 2 March 2012

The first report via traditional media came from Algoa FM, followed by other media:

- **Algoa FM: Three rhino poached in Eastern Cape game reserve**
 - ▶ 08:58 (GMT+2), Friday 2 March 2012; www.algoafm.co.za/article.aspx?id=1014
- **SABC News: Another rhino poached**
 - ▶ Nomawethu Solwandle; Friday 2 March 2012 14:50; www.sabc.co.za/wps/portal/news/main/tag?tag=Rhino%20poaching



- **Metro Newspaper: Three rhino poached at Kariega Game Farm**
 - ▶ Written by: Derrick Spies
 - ▶ Published: Friday 2 March 2012; <http://www.metronewspaper.co.za/2012/03/02/three-rhino-poached-at-kariega-game-farm/>
- **NBC News: Poachers attack rhinos featured in Rock Center report**
 - ▶ Friday 20 April 2012 11:09; http://rockcenter.nbcnews.com/_news/2012/04/20/11306793-poachers-attack-rhinos-featured-in-rock-center-report?lite
- **AOL on News**
 - ▶ March 2012; <http://on.aol.com/video/rhino-poaching-shocks-south-african-reserve-517308162>
 - ▶ Video by Associated Press: Rhino Poaching Shocks South African Reserve
- **Sky News: Rhino poaching deaths set for record high in 2013 – Veterinarians race to save mutilated animals with horns and parts of their faces ripped away by poachers**
 - ▶ Sunday 22 September 2013 9:01; <http://www.desdemonadespair.net/2013/09/rhino-poaching-deaths-set-for-record.html>
 - ▶ Posted by Jim on Sunday 22 September 2013
- **Sunday Times: Times Live: Rhino dies after horn sawed off**
 - ▶ SAPA 26 March 2012 09:05; www.timeslive.co.za/scitech
- **Kariega Game Reserve pays tribute on one year anniversary of poached rhino's death & celebrates a feisty lady**
 - ▶ Posted 25 March 2013 by Africa Geographic Editorial in Conservation
 - ▶ <http://africageographic.com/blog/kariega-game-reserve-pays-tribute-on-one-year-anniversary-of-poached-rhinos-death-celebrates-a-feisty-lady/#sthash.CXDQ8Dfv.dpuf>

Postings on Kariega's digital media

Kariega featured in Wildlife Extra blog: Thandi, the rhino that survived

Posted on Kariega website and Facebook on 22 November 2012. Filed in Thandi and Themba.



– See more at: <http://www.kariega.co.za/blog/kariega-featured-in-wildlife-extra-blog-thandi-the-rhino-that-survived>

Rhino Requiem – music video dedicated to Thandi and Themba

Posted on Kariega website and Facebook on 29 November 2013. Filed in Thandi and Themba, Video Journals.

Music video to raise awareness in the fight against rhino poaching – Kariega Game Reserve South Africa

– See more at: <http://www.kariega.co.za/blog/rhino-requiem-music-video-dedicated-to-thandi-and-themba>

Thandi's Story goes to Vietnam and China

Posted on Kariega website and Facebook in September 2013. Filed in Thandi and Themba, Conservation Blog.

Yao Ming in Africa to raise awareness against poaching

NGOs take Thandi's story to Vietnam and China

Anti-poaching awareness in China

– See more at: http://www.sagoodnews.co.za/environment/thandi_the_rhinos_story_goes_to_china.html and <http://www.kariega.co.za/blog/thandis-story-goes-to-vietnam-and-china>

What we hope to be Thandi's last treatment

Posted on Kariega website and Facebook on 23 October 2013. Filed in Thandi and Themba. <http://www.kariega.co.za/blog/what-we-hope-to-be-thandis-last-treatment>

Kariega Game Reserve – Thandi the rhino is pregnant!

Posted on Kariega website and Facebook on 7 December 2013.

– See more at: <http://www.kariega.co.za/blog/kariega-game-reserve-thandi-the-rhino-is-pregnant>

Survivor of a horrific poaching attack in March 2012 at Kariega Game Reserve South Africa is going to be a mother

– See more at: <http://www.kariega.co.za/blog/kariega-game-reserve-thandi-the-rhino-is-pregnant>



Thandi the Rhino: Photos, May 2014

Posted on Kariega website and Facebook on 16 May 2014. Filed in Photo of the Week, Thandi and Themba.



Figure 13.3 Pregnant rhino Thandi grazing with wildebeest at Kariega Game Reserve

This photo of Thandi was taken recently by Kariega Game Reserve operations manager Jason Loest. Thandi's horns were hacked off by poachers in March 2012. She has shown incredible bravery and an amazing will to survive to become a beacon of hope in the fight against rhino poaching.

Thandi is pregnant and is expected to give birth sometime around December 2014. White rhino females reproduce every two and a half to five years. They give birth to a single calf, which lives with them until it is about three years old.

– See more at: <http://www.kariega.co.za/blog/thandi-the-rhino-photos-may-2014>



Save the Rhino projects and initiatives



**HELP
PROTECT
AFRICA'S
RHINO
!**

**Calling all
teachers,
parents,
students
& friends!**



**Join our school challenge today—
inbox us for more information on how
your school can HELP!
OUR FUTURE—OUR RESPONSIBILITY**

Figure 13.4 Rooting for Rhino School Route Challenge

[https://www.facebook.com/pages/Rooting-for-Rhino-School-Route-Challenge/
255953621187748](https://www.facebook.com/pages/Rooting-for-Rhino-School-Route-Challenge/255953621187748)



Figure 13.5 School in Holland participating in the Rooting for Rhino Project

<https://www.facebook.com/TheTravellingRhinosProject>

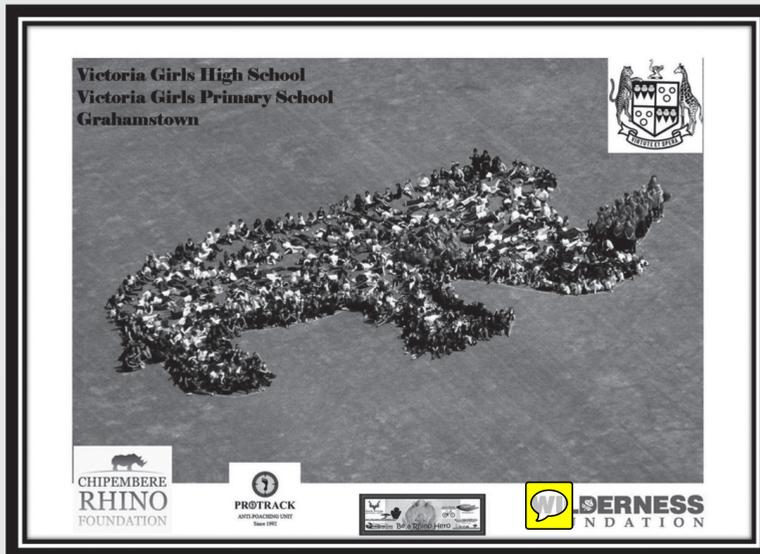

Figure 13.6 School in Grahamstown participating in the Rooting for Rhino Project

<http://rhinoanthology.files.wordpress.com/2012/09/vgrhino1.jpg>





Figure 13.7 The Rhino Run, a South African national trail run held on World Rhino Day

<https://www.facebook.com/RhinoRun>

Rhino Day for UK students in support of Kariega Rhinos

Posted on Kariega website and Facebook on 17 January 2014. Filed in Thandi and Themba, Kariega News.

The Khalsa Primary School in the UK recently held a special Rhino Day to raise awareness as well as funds for the Kariega Foundation Save the Rhino fund. All in all they managed to raise an impressive R6 105!

The day included a range of activities including storytelling; an obstacle course; making clay rhinos, masks, rhino biscuits, rhino badges, awareness artwork and leaflets; designing book covers for 'Wild Fire' (a book about poaching); and even turning their own teachers into rhinos! You can see all the lovely pictures here.

The day was inspired by a visit from Zindzi – the travelling rhino – who came to visit the Y5 class and help them learn about rhino poaching in South Africa. Click here to learn more about The Travelling Rhinos Project.

A very big thank you to the Y5 class for having Zindzi, and a big thank you to all the school students, teachers and parents who participated in the Rhino Day on 18 December 2013. It was wonderful to hear about your fundraiser, and we felt very proud to be chosen as the benefactor of your project. Students can be very proud of their achievements because the funds raised will go a long way to help look after Thandi and protect our rhino. We hope that you continue in this spirit, setting an example to us all.



– See more at: <http://www.kariega.co.za/blog/rhino-day-for-uk-students-in-support-of-kariega-rhinos>

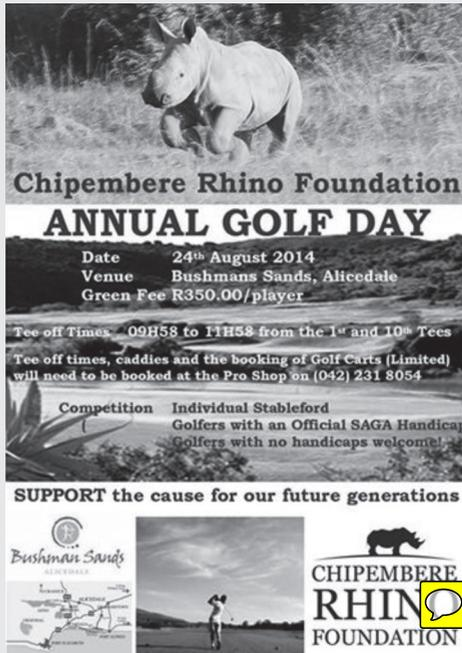

Figure 13.8 Fundraising Golf Day for the Chipembere Rhino Foundation (CRF), which is a privately run, registered non-profit and public benefit organisation comprising of a dedicated team of conservation specialists committed to assisting in the protection and conservation of Africa's rhino (<https://www.facebook.com/Chipembererhinofoundation/photos>)

Source: Case study and images courtesy of Mark and Graeme Rushmere, co-owners of Kariega Game Reserve

➔ Summary

From these examples, the possibilities of the various media as well as the variety of issues that a public relations practitioner has to face each day become clear. The creative public relations practitioner can turn many events into excellent opportunities to assure good media coverage.

ESSENTIAL JOURNALISTIC SKILLS FOR THE PUBLIC RELATIONS PRACTITIONER

The everyday responsibilities of a public relations practitioner include various tasks of a journalistic nature. These are not only directed at the media, but also include the application of journalistic skills in public relations where a knowledge of the basic principles of interviewing, photography, writing, design and page layout leads to a finer end result.

Public relations practitioners responsible for internal and external house publications could be considered 'internal' journalists or editors. These public relations practitioners also look for news, conduct interviews, take photographs, write and edit articles, and do page layout according to deadlines. Although the nature and content of internal and external house publications differ considerably from the mass media, the basic principles stay the same.

Public relations practitioners are often inundated with tasks, eg designing invitation cards, compiling brochures and pamphlets, writing media releases, editing annual publications, etc. Basic journalistic skills will enable the public relations practitioner to maintain a high standard when doing these tasks.

This part of the book deals with the various journalistic skills that public relations practitioners need in their everyday work. In Chapter 2 we explored the skills of the public relations practitioner that overlap those applied by journalists. This section links with Chapter 2. In it, we will discuss how these skills are applied by the public relations practitioner.

In Part 3, we deal with the following journalistic skills applied by the public relations practitioner: interviews, photography, writing, editing and design (including page layout and desktop publishing).

CHAPTER 14

Interviewing skills



Objectives

After you have studied this chapter, you should be able to:

- conduct an interview (as a public relations practitioner)
- handle interviews by various journalists from different media
- apply general guidelines when dealing with the media.

Introduction

Interviewing is one of the journalistic skills that the public relations practitioner uses frequently. Journalists have various external sources with whom interviews might be conducted to gather information aimed at a wide target audience. Public relations practitioners are limited to sources close to their organisation since their main aim is to gather information about the organisation, its activities, management or employees for in-house publications, external publications and the media. The public relations practitioner's chief sources are management, employees, former employees or pensioners and, sometimes, members of the community or other relevant sources, such as family and friends of management or employees.

Public relations practitioners do not only interview relevant sources for internal or external publicity – they are often interviewed by the media for information. They therefore act as *interviewers* and as *interviewees* (respondents). They conduct interviews to gather information, for example, for in-house publications directed at a specific target group, eg employees.

Interviewer: a person conducting an investigative discussion

Interviewee: a person responding to a series of investigative questions

Journalists interview the public relations practitioner to gather information for publication or broadcast via the mass media directed at either a specific target audience – such as a professional group of architects for an architectural magazine – or to an unknown broader public audience.

In this chapter, we focus on public relations practitioners' application of interviewing skills and how they should handle journalists when being interviewed. General guidelines for dealing with the media are also discussed.



Exercise

1. Describe, in your own words, the term interviewing.
Compare your description with the following: Interviewing is the gathering of information about a specific topic or person for the purpose of writing a news report, article, profile or feature for publication or broadcast.
2. Read through the introduction again and describe the difference between an interviewer and an interviewee.



Take note

In this chapter, interviewing should not be confused with discussions held to fill a vacant post. There is a big difference in the planning of and approach to an interview for publication or broadcast purposes and a job interview.

How to conduct interviews (as interviewer)

The public relations practitioner should know how to conduct interviews as a successful interview and its publication in a suitable publication can earn credibility.

In the following discussion, we look at the practical aspects of arranging and conducting interviews. To guide you in preparing for and conducting an interview, we use the following example: a new managing director has been appointed at your organisation and you plan to interview him or her.

The guidelines that follow can be used for any interview.

Factors to consider

Objective

Establish the aim of the interview. You must know beforehand what you want the interview to achieve. The main objective is to introduce the new managing director to the target group.

Type of publication

Ask yourself this question: In which house publication will the interview be published? Since we differentiate between internal and external house magazines, you should know in which one the interview will be published. If you decide to publish it in both, this will lead you to another question.

Readers

Who are the readers of the internal or external house magazines? If the interview is published in the internal house magazine, the readers will comprise the organisation's present and past employees and perhaps their families. If the interview is published in the external house magazine, the readers include anybody outside the organisation, eg shareholders, community leaders, distributors and dealers, etc.

It is important to answer these questions, since the reason for the interview, the type of publication and the readers you are targeting will affect your preparation and the questions you will ask.

Preparing for the interview

You need to plan the interview before you can conduct it. It is important to gather as much information as possible about the new managing director before the interview. In the planning phase, you should attend to the 5Ws + 1H questions, ie Who, What, Where, When, Why and How? You can find answers to these questions in the following ways:

- ▶ Research is important. You should trace the MD's career back through other organisations. You might have to visit these organisations' archives to get background information. You might also want to speak to the MD's former colleagues to gather more recent information. Background information helps you to become acquainted with interviewees before you meet them. It also helps you to prepare a list of questions.

Asking discerning questions about their background creates the impression that you are a professional public relations practitioner.

- ▶ Following your research, you need to list several structured questions. Begin with light questions, move to more serious ones and then round off the interview. Keeping your objective, publication and readers in mind, ask questions that will realise your objective and interest your readers. Questions on issues such as the interviewees' career path, interests, ambitions, hobbies and family can assist in introducing them to your readers. Remember that your questions should be sensible. Although a list of questions is a useful guide during an interview, you should allow yourself to deviate from your original questions. It often happens that an answer leads to a different line of questioning. This adds value to the planning you did before the interview.
- ▶ Decide on the *resources* you will use during the interview. Will you write the answers in a notebook or will you record the interview? You may decide to use both methods. If you use a voice recorder, you must remember to ask permission from the interviewee (in this case, the managing director) to record the interview. Some people do not like to be recorded and you may therefore need their permission. It is advisable that you use one of these two resources as it is impossible to remember all that was said.
- ▶ Set a time for the interview. Although this may sound logical, it is a very important point. You can hardly expect the managing director to leave a meeting to grant you an unexpected interview. Setting a specific date and time for the interview will give the MD a chance to anticipate possible questions and to prepare answers. An appointment should be made through the managing director's secretary. Do not volunteer a list of questions beforehand. You want spontaneous answers to add to the liveliness of the interview. However, if the MD insists on receiving a list of questions beforehand, you can hardly refuse.

Resources: a supply of tools that can be used

Conducting the interview

The ideal would be to become acquainted with the managing director before setting up the interview. However, this is not always possible.

On arriving for the interview, introduce yourself in a friendly manner. Although you should be at ease, do not become familiar. Be professional at all times.

It is advisable to have an informal chat with the managing director before the interview. This will put him or her at ease. You can then begin your formal, prepared line of questioning. If you are using a voice recorder (with permission), turn it on and make sure that it records the whole interview.

If you are using a notebook, make short notes while writing down answers. If you do not have *shorthand* skills, it is suggested that you develop your own style of abbreviated writing. It is not possible to write answers down word for word – somewhere along the way you will find that you have lost words or sentences. This could result in a disastrous interview. Write down the answers' core words, which will enable you to restructure the interview properly afterwards.

Shorthand: a method of rapid writing in abbreviations and symbols

It is important to listen carefully to answers and to make sure that there is no misunderstanding. Rather ask an interviewee to repeat or rephrase an answer if you do not grasp its meaning. Also, if you are going to use direct quotations, you have to use the interviewee's exact words.

During an interview, it could happen that the person strays from the point. If this happens and you feel the information is irrelevant, gently steer him or her back to the point under discussion. You should control the interview.

If you are unsure of the correct spelling of the managing director's name and surname, ask him or her for it – do not be afraid to do so. You will be more embarrassed by a misspelled name or surname when the article is published than you will when asking for the correct spelling!

Remember to maintain eye contact during the interview (but do not stare), smile or nod your head to show understanding, and look interested – it is up to you to make the interview a pleasant and rewarding experience.

Once you are satisfied that you have sufficient information, thank the interviewee for granting you the interview.

Your next step will be to write a profile. Refer to Chapter 16 in which writing skills are discussed. You may also want to photograph the MD (with permission) during the interview. Chapters 15 and 16 will provide guidelines on taking appropriate photographs and writing a pertinent caption.

How to handle an interview (as interviewee)

We have dealt with the public relations practitioner as the interviewer. In this section, we discuss how the public relations practitioner should act when being interviewed, ie as the interviewee.

This section links to Part 2 in which we discussed various media, ie newspapers, magazines, television and radio. You should therefore be aware of the differences between these media and their requirements.

A journalist may interview you on the telephone. However, he or she is more likely to choose to interview you at your office or, perhaps, at an agreed venue (depending on the reason for the interview).

We will use the following example to guide you through the interview:



Example

You are a public relations practitioner for a zoo at which a baby chimpanzee's birth has caused great excitement. This is the first chimpanzee conceived *in vitro* in South Africa.

Journalists from the different mass media arrange to interview you on this event. You now have to prepare yourself for these interviews.

Preparation

Anticipate the journalist's questions. Answers to the traditional 5Ws + 1H ones will be helpful. Who performed the procedure? Where and when was it performed? How was it done? Did the mother chimpanzee experience any difficulties during pregnancy or while giving birth? How much did the baby chimpanzee weigh at birth? Is it feeding from the mother? Answers to these questions will be important.

To find the answers, you will have to speak to the doctors involved in the procedure and those who attended the birth of the baby chimpanzee. You will also have to speak to the person tending it. Make notes of the information you have obtained as you will have to relay it to the journalist.

You should get permission and make arrangements for a photograph and other visual material of the mother and baby to be taken for the newspaper, magazine or television. Radio journalists may also need photographs to post on their Facebook page.

The interview

When the journalist arrives, make him or her feel welcome. Be relaxed when answering questions. Listen carefully to the question and only answer what is asked. Do not elaborate on issues unless the journalist requests more information. If a question is asked for which you do not have an answer, be honest and say that you will get the information. Do not try to ignore the question. Rather make a point of obtaining the information as soon as possible.

When the journalist is satisfied that sufficient information has been obtained, accompany him or her to the baby chimpanzee for the photographic or visual session.

Remember, each event and each situation might require different actions from you. The above is just an example of how you can prepare yourself for a successful interview.

Interviews with radio journalists are usually recorded. In the case of television, you will probably be interviewed on camera. The best advice any interviewee can be given is to relax, relax, relax! If you are tense during the interview, the tension will be heard in your voice and will show on your face. The only way to learn to relax for interviews is to practise. Further hints and tips for a television interview are given later in this chapter.



Exercise

You will need a voice recorder, a video recorder and a video playback facility to complete the following exercises.

Exercise 1:

Use a specific event or happening at your organisation and prepare possible answers for an interview. Ask a colleague to act as a radio journalist (interviewer). The interview must be recorded. The journalist will ask you for a voice test to set the correct volume on the recorder. This will be played back and you may be asked to speak more loudly or softly, more slowly or quickly. Once the journalist is satisfied, begin the interview.

On completing the interview, play it back and listen to it critically. Note the areas in which you need more exercise. Practise, practise, practise!

Exercise 2:

You are now being interviewed by a television journalist. Your colleague has to use a video recorder for this exercise. The difference here is that the interview is recorded immediately – there is no test run. When the interview is finished, use the video playback facility and analyse your appearance, facial expression, and the tone and pitch of your voice, etc. Once again, practise, practise, practise!

Remember: practice makes perfect!



Take note

If you do not have video facilities, practise in front of a mirror.

Tips for a television interview

If the interview is going to take place at the television studio, you should allow the use of make-up on your face since the studio lights become very hot and if you or your subject sweats in an interview it could give the impression of guilt. Make-up will stop you from sweating excessively under the lights.

There are usually several cameras in the television studio. Do not look at them or at the activity around you – focus on the interviewer. It is not your concern if and when the camera focuses on you – your attention should be on the interviewer.

Listen carefully to the questions and do not elaborate on an answer – airtime is limited.

When a television journalist approaches you for an interview, ask whether you will be alone or whether you will be part of a panel discussion for a television programme. If you are a panellist, wait for the interviewer to address you before giving your answer. Do not interrupt others on the panel. If you feel that you would like to comment on another panellist's answer, indicate to the interviewer that you would like to speak. The interviewer is in control and you must abide by his or her decisions.

To acquaint yourself with the set-up of a radio or television studio, arrange a visit to the studio. If you know how studios operate, you will feel more at ease when confronted by the real thing.

Public relations practitioners should use their knowledge to prepare and assist members of management who are often in the interviewee's hot seat.

General tips for handling the media

This section gives a few tips that might assist you in dealing with the media.

- ▶ Never say 'No comment'. Whenever a journalist approaches you for a comment on an issue – especially a sensitive one – saying 'No comment' will take you nowhere. You should remember that the journalist already has a story that he or she will publish or broadcast. Rather take the opportunity to guide the journalist in objective reporting. You will be much more credible when giving information, even on sensitive issues.
- ▶ Do not give information about which you are not sure. Rather tell the journalist that you need to verify the facts; then contact the journalist the moment you have them.
- ▶ Never promise to telephone back and then 'forget' to do so. This is bad manners. Even if you do not have the necessary information available, telephone the journalist and update him or her on your progress.
- ▶ Do not take any chances by giving information 'off the record'. Journalists thrive on information that you do not want to have published or broadcast.

- ▶ Never try to hide facts. The journalist's work is to dig for information. You will cause more damage in trying to hide facts and information than you will by being frank. Credibility is earned by being open and honest.
- ▶ Trust the journalist. Never ask him or her to fax you a copy of the news report or article before it is published or broadcast. Journalists abhor this. They work to tight deadlines and do not have the time to send information back and forth. Rather invite the journalist to contact you if he or she is unsure of any facts.
- ▶ Do not demand that the journalist tells you when the article, news report, etc, will be published or broadcast. The journalist does not control the publishing or broadcast of material. The final decision lies with others. It may happen that nothing is published or broadcast. Do not hold it against the journalist. Remember, there are many journalists covering many events and happenings throughout the day. If your story has more news value and is more important to the public than other stories of the day, you will get the publicity.
- ▶ Never become despondent after having spent many hours with a journalist only to find that you get no publicity. Your day will come. Act professionally at all times. Be helpful and polite, and never lose your temper.
- ▶ Always give the name and designation of the person acting as spokesperson, eg Dr Neil Barnard, heart surgeon at the Ga-Rankuwa Hospital; or Cathy Mokoena, public relations practitioner at Telkom, etc.



Take note

Remember, it is up to you: The journalist can be your greatest friend or your worst enemy!

Interview scenarios to consider

Consider the following scenarios (adapted from Shure, Burnett & Brown 2005: 19–22). Based on the premise that interviews may be scheduled for a few seconds, five minutes or longer, rather limit yourself to the three most important points that you want to make. These will become your 'islands of safety', to which you will return again and again during the interview.

Below are several scenarios that may arise when dealing with interviews. Consider the following:

- ▶ The interviewer may change the focus of the interview, making it difficult for you to make the points you want to make. If this happens, politely but firmly return the interviewer to the topic by using verbal bridges such as 'The most important issue here is ...' or 'The real issue remains ...'.
- ▶ The interviewer may ask you a question that you would prefer not to answer. If this happens, make your way back to an 'island of safety', which is one of the points that you prepared before the interview. Try to incorporate a story into the 'island of safety', as people remember stories.
- ▶ The interviewer may interrupt your answers with more questions. Allow this to happen, but then say, for example, 'There are several questions you've asked me that I need to answer.' Then choose one of the questions that you could answer with one of your prepared points, and answer that one. If the interviewer's interruptions are taking the interview far from the direction in which you want it to go, politely say, 'As I was saying ...', and continue to discuss one of your prepared points.
- ▶ If the interview runs into a long silence, do not feel pressured to say anything. It is the interviewer's responsibility to keep the interview going. Interviewers sometimes use these silences to get interviewees to give information that may be revealing. Avoid doing this.
- ▶ The interviewer may ask you to say more than you want to say about an issue. If you are expected to keep talking, make sure that you make your way back to a prepared point and talk about that, possibly including different examples or stories to illustrate the same point.
- ▶ If you do not know the answer to a question, it is important to be honest and say that you don't know. Tell the interviewer that you will find the answer and get back to him or her.
- ▶ Answer questions with answers that do not exceed about 20 seconds. Your answers can be longer for print media and shorter for media such as radio.
- ▶ Remember that most communication happens on the non-verbal level. So, you should pay attention to your appearance and how you sound. Ensure that you come across as being energetic and enthusiastic about the interview's content.

To see how you appear on film, record a practice session and play it back to yourself. If you are being interviewed on television, keep the following guidelines in mind: wear lighter colours that are solid and not patterned; avoid fabrics that shine or flash; keep accessories to a minimum; and make sure that you are wearing make-up.

- ▶ Finally, never say anything to an interviewer that you do not want him or her to use – even when you think the microphone is off and when the interview has officially not begun or has ended. You need to be prepared to read or hear anything you have said in the interview in the print or electronic media.

Summary

The public relations practitioner plays two roles in interviewing, ie that of interviewer and interviewee. As interviewer, skills are needed to conduct an interview, for example for in-house publication purposes. As interviewee, the public relations practitioner gives information to journalists for publication in the mass media. The correct handling of different media is of utmost importance in ensuring a successful interview.

The general hints and tips given for television interviewing and media handling should assist you when you are confronted by a real, live interview.

Test yourself

1. Explain, in your own words, what the term interviewing means.
2. What is the difference between the interviewer and the interviewee?
3. List and discuss the three main factors you need to consider when planning to interview an employee at your organisation.
4. You need to prepare for an interview with an employee who is retiring after 30 years' service in the organisation. Detail how you, as the interviewer, will prepare and conduct the interview.
5. A journalist from a newspaper asks to interview you about employees striking at your organisation. Discuss in detail how you will prepare for and handle the interview.
6. A television journalist asks to interview you about the same strike. Discuss how you will prepare for and handle this interview.

Photographic skills



Objectives

After you have studied this chapter you should be able to:

- understand the basic features of a digital camera
- recognise various organisational opportunities for photographs
- take better photographs.

Introduction

Photography is an invaluable and effective journalistic skill for the public relations practitioner. Knowledge of photography will enable the public relations practitioner to take photographs not only of organisational happenings and events for in-house publications, but also for the print media and social network platforms such as Instagram and Flickr. Photography has gone through an exciting transition period during the last few years because of the new capabilities of *digital cameras*. The advantages of digital cameras over their analogue counterparts are that the finished images can be reviewed immediately and erased, if necessary; one picture can be printed without waiting to develop an entire roll of film; and the storage mechanism most widely used for digital photography – the memory card – is reusable.

Social media has brought further changes to the world of visual communication, and of photography in particular. 'The focus of visual communication is shifting to immediate and

Digital cameras: cameras that capture images electronically, using units called charge-coupled devices (CCDs), instead of on film; users can transfer the images from the camera's memory card to a computer for editing and storage

up-to-the-minute photographic coverage, with timely and current visuals being the 'holy grail' (Le Roux nd).

It is becoming increasingly important for journalists, communications practitioners and PR practitioners to be skilled photographers, with people in these professions often having to assume the role of photographers themselves (Le Roux nd). This is because the communications require coverage of events as they happen (Le Roux nd).

Public relations practitioners need to be able to use tools such as tablets, smartphones, digital single reflex cameras (DSLRs) and compact point-and-shoot cameras to capture the images they need. They also need to understand the photographic medium to control the lighting, composition, perspective and contrast of the shots they take (Le Roux nd).

This chapter provides basic guidelines on the technical aspects of digital cameras. Some practical advice is offered as we look at the advantages that photographic skills hold for the public relations practitioner. Useful tips for taking photographs are also looked at.

The best way to acquire good photographic skills is to practise and to experiment with the camera, and to become acquainted with how it works and what it produces by setting up various scenes and taking photographs from various angles.

Those who are keen to become good at photography should take a course to acquire all the basic skills. Public relations practitioners should realise that photography is as important as any other communication tool, and should not be seen as the domain of the professionals. Knowledge of photography will not only enhance your own skills but will also help whenever it is necessary to use a professional photographer.

Features of a digital camera

The first step to becoming a good photographer is to become acquainted with the camera. There are many types of cameras available and the best way to learn how to operate one is to work through the instruction booklet that comes with it.

Digital camera features vary greatly from model to model. Some might be essential to a particular person, while others might be of use only for highly specialised applications.

Basic digital camera terms

Understanding the basic terms with regard to digital cameras will enable users to have more control over a camera's features and will help them take the best-quality photos possible.

- **Megapixel (resolution):** The term megapixel refers to the sharpness or detail of a picture. A million *pixels* make up a megapixel (MP). The higher the number of pixels, the higher the resolution. A camera that captures three million pixels, for example, is called a three-megapixel camera. A higher megapixel count means better-quality photos. Picture size is measured by how many pixels make up an image and this is done according to horizontal by vertical resolution, as in 1 280 × 960. The resolution required will be determined by the purpose of the photos. (See the explanation of the purpose of high- vs low-resolution images later in the chapter.)
- **Focal length (lens):** Focal length refers to the extent to which a lens is able to magnify a shot – in other words, how much of the scene you are capturing will fit into the frame. Some lenses have a fixed focal length, while others, such as zoom lenses, have a variable focal length. Many cameras and lenses have an autofocus function, which means that you do not have to focus them manually.
- **Optical vs digital zoom:** In photography, we distinguish between two types of zoom lens, namely optical and digital. Optical zoom uses the elements inside the lens itself to zoom in to a scene, retaining the detail of the scene and keeping image quality high. Digital zoom uses a process of enlarging the pixels of an image, which means that image quality decreases.
- **ISO:** ISO, which means International Standards Organisation, is a measurement of the sensitivity of the camera's sensor to light. The International Standards Organisation is an organisation that sets standards for a range of fields, including photography. You use a low ISO (an ISO of 100 and lower) to shoot images when lighting conditions are good. You use a high ISO to shoot images in low light. Most photographs, shot in good light, are shot with an ISO of 100 to 400.
- **Shutter lag:** This is the time that elapses between your pressing the shutter button to take a shot and the camera taking the photograph. It is important to know what the shutter lag of your camera is so that you do not miss the shots you need.

Pixel: a contraction of the term picture element; digital images are made up of millions of tiny squares

- **Memory:** Digital cameras store pictures as data files. The size of the memory determines the number of pictures that can be taken before downloading them to a computer, at which time the memory can be filled up with new pictures. Most cameras come with only eight megabytes (MB) of memory, which for a two- or three-megapixel camera could be only 10 to 40 photos. A removable memory source, such as a memory card, may be purchased to provide more memory space.
- **Flash type:** A flash is the extra light needed to shoot indoors or in low-light conditions. Most digital cameras have built-in flashes. Other flash options include red-eye reduction that emits two flashes. The first contracts the iris so that the eye reflects less light with the second flash. There is also the option of attaching an external flash that is much more powerful than the automatic flash.
- **LCD screen:** An LCD screen shows what the photograph will look like and displays pictures or images that have already been taken. It also allows the user to erase what is not needed.
- **Data transfer:** Digital cameras come with a USB cable for transferring images directly to the computer. Many computers have one or more memory card slots. Printers may also have card slots, allowing photographs to be printed without using a computer. Wireless (Wi-Fi) transmission is also available on some cameras.
- **Battery duration:** Digital cameras use either rechargeable or standard AA batteries. It can take an hour or more to recharge a battery – so having an extra, fully charged battery is recommended. AA batteries are readily available.

Other important photography terms

- ▶ **Composition** is simply defined as the organisation of space within the photo. It is the combination of the subject matter within the photograph and its position in the picture scene. The position of the subject/s within the photograph can improve the way pictures look. Important factors to consider when composing a photograph are:
 - the centre of interest
 - leading lines
 - balance
 - contrast.

- ▶ **Exposure** refers to the amount of light required to produce an acceptable image when taking a photograph. Under-exposure means that there is too little light, resulting in dark, undefined images. Over-exposure refers to too much light, resulting in images that have a poor resolution.
- ▶ **Aperture** is a hole of variable size inside a camera lens. The size of the aperture controls the quantity of light entering the camera.
- ▶ **Depth of field** is the distinct focused area/zone in the photograph. The depth is how deep into the subject the distinct focus area/zone starts and ends.

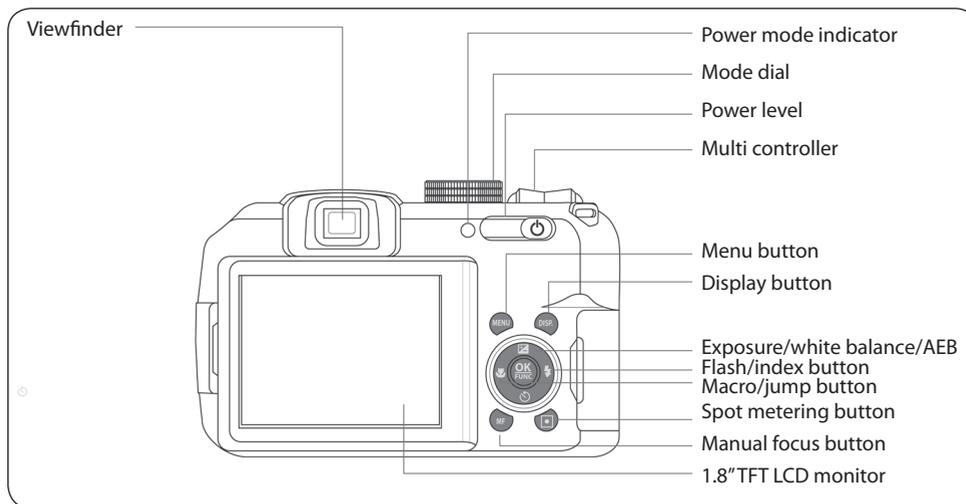

Figure 15.1 Basic parts of a digital camera

Practical photography

Advantages of photography for public relations practitioners

Before we discuss aspects of good photography, it is necessary to establish the advantages of taking your own photographs. As a public relations practitioner, you create publicity for your organisation and take pictures that support the event or purpose of the publicity. As such, you must realise that publicity and public relations photographs do not revolve so much around a particular subject as they do around a particular purpose.

For example, your organisation is involved in a project to assist the local community in growing their own vegetable gardens. On commencement of the project, the managing director (MD) of your organisation visits the community for the turning of the soil ceremony. You go along to take pictures of this event. You should focus on taking pictures in which the MD and a few community members hold the spade together, digging the first hole. In other words, taking a picture of the MD alone as subject with the spade says nothing of the purpose of his visit, but taking a picture with him and the members digging together says something about the purpose of his visit.

In-house publications (hard copy or online)

Public relations practitioners responsible for in-house publications can illustrate articles in the newsletter or magazine with photographs. For example, you might want to take a photograph of the new managing director to accompany your feature story or profile. Staff members may not know what he or she looks like and there is no better way of introducing the employees to their new managing director than with a photograph!

Furthermore, a good photograph can tell the reader more than words can describe. You are familiar with the expression 'a picture paints a thousand words'. Here one can imagine, for example, a group of miners throwing their hardhats into the air, celebrating a million hours of accident-free shifts.

Certain organisational events, such as family entertainment days, can sometimes be best described by a photographic spread in the newsletter or magazine. Here, the story is told by photographs and their captions.

Press kits

Your press kit will have more value if you include photos (and/or video clips). Circumstances sometimes prohibit journalists from taking photos. For example, suppose a child has undergone a successful heart-lung transplant operation. Journalists would not be allowed into the hospital ward to take photos of the child due to the high risk of infection. Providing a photograph of the child as part of your press kit can overcome obstacles that prevent the media from taking their own photos or problems that arise due to distance – for example, if a newspaper from

another region wants to use the photo. (Photographs of children in hospital may only be made available to the media with the written consent of their parents.)

When including photographs with press kits, it is a good idea to make two or three different ones available so that journalists can choose which ones they wish to use. For example, the child who underwent the operation can be photographed alone, with her parents and with the doctor who performed the operation.

Photographs for press kits should be of a high quality for the print media. If the quality is in doubt, it is better either to leave them out or to hire a professional photographer to take some more.

This also applies to press kits for your *online newsroom* (see Chapter 16 for more details) – make sure your photographs are of high-resolution quality that is appropriate for print in newspapers and magazines.

Photo library

We distinguish between the PR department's internal photo library and the organisation's online photo library.

The public relations practitioner should establish a photo library from which photos of directors, management, senior staff members and other relevant photos of the organisations' employees and activities can be downloaded for internal use (for internal and/or external newsletters, etc). A photo library can be extremely valuable if a photo is needed urgently – for example, a staff member is promoted to a managerial post and you want to place his or her picture in the newsletter. However, the staff member is overseas and you can't take a picture of him or her. Having photos available of the staff member to download from the library will solve your problem.

The photo library of staff members should be updated every few years. It is a fact that we all change as we get older, whether we like it or not, therefore it is important to keep fairly recent photographs of staff members.

Most organisations have an online library link on their website showcasing a gallery of photos ranging from the organisation's activities and services to special events and happenings at the organisation. You should post photos regularly on the library

Online newsroom:
a website that contains information about the organisation to target traditional media outlets such as newspapers, magazines and television; can also be used by radio for posting on the radio station's Facebook page

link of events and happenings at your organisation that may be of interest to stakeholders or other target audiences. It may also happen that a journalist notices an interesting photo that he or she wants to use to write an article or news report accompanying the photo. At the same time, don't inundate your photo library with nonsensical photos, and make sure that you clean out the library regularly, replacing old photos with new ones.



Take note

A very important feature you should be aware of when you post photos for the internal and online library is the difference between high-resolution and low-resolution photos.

High-resolution versus low-resolution images

Resolution describes the detail an image holds – the higher the resolution, the more detail or more information the image has. The detail is referred to as pixels, which are the dots of different colours that make up the picture. The term used is DPI – dots per square inch.

Photos used for online or web graphics can be low-resolution – 72 dpi looks good on a website, for example, but if you print a photo at this resolution it would look pixelated (resembling squares that have been joined together). For printing purposes, image resolution should be 300 dpi or higher (Contemporary Communications Inc. 2012).

For example, a game reserve has a gallery of high-resolution photos – 300 dpi – available in its library for tour operators to download for print in their holiday brochures. (See, for example, www.kariega.co.za/library.) Low-resolution photos can be used for online purposes – for example, a low-resolution photo of the rhino Thandi and her new baby rhino could be posted on the library for online use by the *Sunday Times*. However, if the newspaper needs the photograph for hard copy, it would require high-resolution photograph.



Fig 15.2 High resolution image (300DPI) left and low resolution image (100DPI) right (Michelle 2012)

Archives

Photographs can be of archival value. The history of organisations is very important. If photographs of management and staff members who have excelled are preserved together with photographs illustrating the organisation's growth and development, it will add great value to the archives.

Displays/exhibitions

Most companies are given opportunities to take part in displays, exhibitions, etc, at which they can make use of good photographs to promote themselves. Photographs from the archives or photographic library can be used for this purpose.

Now that we have established the advantages of taking your own photographs, we will look briefly at various photographic opportunities that may arise at organisations. We explore some ideas about the types of photographs that can be taken.

Photographic opportunities and types of photographs suitable for different occasions

The best way for public relations practitioners to take advantage of photographic opportunities is to know what is happening in their organisation. They should see to it that they are kept up to date about any departmental events or happenings that might

create opportunities for good photographs. They should also be informed about staff members' activities. These activities should not be limited to work. Many staff members have interesting hobbies or are great sportspeople. Knowledge of their activities can broaden the public relations practitioner's ideas and range of plans for in-house publications well illustrated with good photographs.

The type of organisation will determine the type of photographic opportunities. We will therefore only give a limited overview of events that create photographic opportunities and the types of photograph that can be taken.



Take note

Although we give some idea of the type of photographs that can be taken at these events, you should also be creative and take some candid shots, ie photographs taken of people without their being aware of your presence, and who are therefore not posing.

Candid photographs can be extremely interesting and can enliven your publication. These 'natural' photographs often make much better material than posed photographs. They can also generate much fun.

The following are events that create opportunities for photographs. Other events may be added to this list, such as crises or disasters at the organisation, etc.

Functions at the organisation

Almost every organisation holds various functions during the year. Examples include those to celebrate an organisation's centenary, the opening of a new plant, the naming of buildings or lecture halls, the inauguration of the new mayor, etc.

These functions create many opportunities for various types of photographs. Usually, dignitaries are present and photographs can be taken of them with the managing director. Photographs of a social nature can be taken, eg a group of staff having tea. It is surprising how many photographic opportunities arise during a function.

Awards ceremonies

These events, which happen in most organisations when staff members are awarded for their services, afford further opportunities. Faced with these ceremonies, one always tends to take photographs of the managing director presenting the staff member with the award. While this is not wrong, it is not very creative. An unusual alternative would be to take photographs of the award-winning staff member with a group of colleagues without whom he or she might not have excelled, for example.

Management and staff members

Since an in-house publication should contain information about management and employees, photographs of the people concerned can support a story. The most common photograph one tends to take is the head-and-shoulders shot. Again, try something different. The reason for publishing a story about a staff member or manager is often an important issue or an achievement.

For example, a story of a staff member who makes porcelain dolls as a hobby could be well illustrated by a photograph of the person with some of the dolls.

If the story is more serious, eg an important policy change announced by the managing director, a photograph of the MD working at his or her desk is also a change from the traditional head-and-shoulders picture.

Sponsorships, donations or community projects

If an organisation involves itself in any type of sponsorship, donation or community project, there are many photographic opportunities. For example, if the organisation sponsors the upliftment of community sport, a photograph could be taken of children being coached.

Open days, exhibitions and other public relations events

Open days and exhibitions are other events creating interesting photographic opportunities. Public relations practitioners are responsible for keeping abreast of events in their organisations

that offer photographic opportunities for in-house publications or other uses.



Exercise

List opportunities in your organisation for photographs suited to your newsletter.

Opportunities: _____

Now describe the type of photograph you will take for each of the opportunities listed above.

Type of photograph: _____

When planning photographs for an in-house publication, for press kits, etc, there are certain factors that need to be considered to ensure that you take good photographs. We discuss the most important factors in the next section.

Factors contributing to good photographs

Purpose of the photograph

One of the first questions you should ask yourself is whether you need the photograph. Why do you want to take a photograph of a certain person or event? Will it add to the quality or content of your publication?

It is important to answer these questions as photography is expensive. If you have a good reason to take a photograph, you should ask yourself what the photograph is going to 'say' to your readers. This brings us to the next factor.

The relevance to the content of your article

Keep your message in mind at all times! When you use a photograph with a story or article, make sure that the photograph is relevant to its content. Remember, a photograph is used to support the content and must not contradict it. Exclude everything from the photograph that does not help to convey the message.

People

It is very important that your photograph 'lives'. Make use of people in your photographs. For example, if you take a photograph at an exhibition, get somebody to pose with the exhibit. Never take a photograph of 'dead' objects as such photographs are not very interesting to readers.

Background

Always make sure that you have a good background for your photograph. Poor backgrounds lead to poor photography. Often you may have only one chance to take a specific picture and it is therefore important that you do not spoil a good photograph with a poor background. Look for intrusive objects such as lights hanging from a ceiling above the subject's head or other people in the background. Be on the lookout for anything that may distract the reader's attention from the person or group you are photographing.



Figure 15.3 Example of a poor photograph (note the funny 'hat' on the head of the woman in the middle)

In some instances, however, backgrounds may add to the impact of the photograph. Here we think of a photograph taken of a manager with the relevant company's logo or name in the background.

Space

When you take a photograph, make sure that the subject is centred. If you are composing a group photograph, always ask your subjects to stand close together. Do not take photographs with large spaces or gaps between people.

Clarity

When you take a photograph of a single person, do not stand too far away from the subject because his or her face might not be recognisable. The same principle applies to group photographs. Rather choose five people from the group for your photograph than take a picture of 15 people who will not be recognised because of the distance.

Framing photographs

Always make sure that the person you are photographing is well framed. In other words, make sure that you have full sight of the subject on the camera's LCD screen. If you take a head-and-shoulders portrait, make your cut-off point at the collarbone and not under the chin. When you take a full-length picture, make sure that the feet are also in the frame. If you want to get closer but still need depth, frame the subject from the waist upwards.



Take note

Always remember that your photograph can be edited afterwards, but that editing cannot correct what is not there.

Use the highest resolution that the camera offers. This will prevent or minimise the need for cropping in post-editing and ensures the retention of digital information required to produce and improve the image.



Figure 15.4 This picture would portray more detail if taken from the waist upwards

Facial expressions

Make sure that facial expressions suit the event. If you are taking a photograph of someone who has lost a relative, a smiling face is not appropriate.

Faces should not be turned away from the camera and the subject or subjects must look at the camera. Readers will not be interested in their backs or the backs of their heads.

Horizontal and vertical photographs (landscape and portrait)

Sometimes, one tries to take a photograph with the camera in a horizontal position (landscape), squeezing the subject into the horizontal frame. If you have problems with getting a good landscape photograph, turn your camera to the vertical position (portrait).



Exercise

You need to take a photograph of a staff member who has been chosen as a member of the athletics team for the Olympic Games. Describe how you will plan the photograph, give an indication of its content and detail the factors you will consider when setting up the portrait.

General tips

- ▶ Know your camera. Read the manual and purchase a book on the basics of digital photography – look at photography magazines and magazines in your industry to see the images that other people produce.
- ▶ Let there be light. Digital cameras are far more light-tolerant than their film counterparts. Nevertheless, understanding light and how to control it is vital in creating the best pictures. Correct lighting – natural or artificial – is essential for achieving good colour rendition, contrast and the light and shade that create depth and interest.
- ▶ Steady the camera. Some cameras compensate for hand wobble but it is still better to have pin-sharp images from the outset. You can steady the camera against a solid object or use a tripod.
- ▶ If you are taking a photograph outdoors, in the middle of the day, you will find that the faces of the people you are photographing might be marred by shadows. Using a flash to light such shadowing will remove most of it from their faces. This is also a good technique to use when there is too much backlighting in your photograph.
- ▶ Carry spare memory cards in case you need more storage.
- ▶ Transfer and back your images up. Get them off the camera and onto more permanent storage systems as soon as possible. Remember to create a backup copy. When editing digital images, always use a copy of the image and never the original. You can re-edit images in many ways, so do not destroy your originals.
- ▶ Produce a test print on your printer before sending an image or file to an editor.

Things you should never do

- ▶ Do not expect an expensive camera to make you a professional. If you know what you are doing, an inexpensive camera will produce better results than the most expensive camera in the hands of someone without a clue. Digital pictures still need creative inspiration, carefully considered exposure, framing and composition.
- ▶ Do not rely excessively on digital post-editing, which can be costly and time-consuming. Get the best image you can from the outset.

- ▶ Do not forget to back up.
- ▶ Do not panic. The more you use your digital camera, the better you will become and the more fun it will be.

Summary

In this chapter, guidelines are given to enable you to understand the basic features of digital cameras. Although you may have a very good camera, a photograph will only be as good as your control of the camera. When taking photographs, cognisance must be taken of relevance, background, people, space, etc. We looked at the benefits of a public relations practitioner being able to take their own photographs for the organisation and the importance of distinguishing between high- and low-resolution photos posted online.

Test yourself

1. Discuss the basic features of a digital camera.
2. List the advantages of photography for a public relations practitioner who is knowledgeable about it.
3. Your organisation's involvement in community projects affords photographic opportunities. Identify a community project with which your organisation is involved and describe the photographs you intend taking.
4. List and discuss factors you need to consider for taking good photographs.
5. Explain the meaning of high-resolution and low-resolution images. Also explain which measured DPI you will use for images in your photo library for printing purposes and which DPI you will use for images on your home page website. Explain why you chose specific DPI measurements for each.
6. Snow has fallen in Johannesburg for the first time in 20 years. During lunchtime, some staff members decide to build a snowman and they ask you to take a photograph. You are faced with a very white background. How will you overcome this problem and ensure that your photograph is not overexposed?

CHAPTER 16

Writing skills



Objectives

After you have studied this chapter, you should be able to:

- explain why basic writing skills are important for the public relations practitioner
- identify and describe the various types of article often written by public relations practitioners
- write a media release and feature article
- write captions, headlines, etc.

Introduction

Public relations practitioners in most organisations are responsible for a considerable amount of written material, from *annual reports* to internal newsletters, invitations, pieces on the company website and media releases. Apart from writing most of this material, they often have to edit and approve many other documents written for different purposes by other staff members.

This can be a heavy burden as the image of any company is, to a great extent, dependent on such printed matter. A typing error on an invitation card could create a negative perception, or it could result in a costly reprint.

Apart from writing or editing written material, the public relations practitioner often has to make decisions about the final layout of organisational publications. This function is important and is dealt with in Chapter 17.

Annual report: a report containing important information about the company's past year, circulated among interested parties

Writing skills needed by public relations practitioners

Although not all public relations practitioners are born writers, a natural talent for writing is invaluable. It is unthinkable not to have a proper command of language and grammar. Computerised spelling checks and other means of checking language and word choice can eliminate unnecessary mistakes, but should not be relied upon exclusively.

Although public relations is a very different profession to journalism, public relations practitioners can learn a lot about writing from journalists. Even though journalists, especially news reporters, tend to write anything and everything according to the '5Ws + 1H', nicely fitted into an inverted pyramid structure, they never bore readers with unnecessary and unimportant detail.

Public relations practitioners need not write according to a newspaper style but, in certain circumstances, doing so could be used to their advantage. Using this formula, facts about organisational change, new policies, procedures, etc, can be arrestingly written. But what do public relations practitioners have to write most often? What is expected of them and how do they approach different issues?

In addition, as a public relations practitioner you need to ensure that you have an adaptable writing style – not only because you will be writing for various media mediums and outlets but also because with the advent of technology, online writing has become an important part of a public relations practitioner's job. Later in the chapter you will learn some tips for online writing.

Let us look at the public relations practitioner's most common writing responsibilities.

Media releases

What is a media release?

A media release, also known as a news or press release, is a written document designed to deliver a newsworthy or noteworthy message to the media, usually with the purpose of generating publicity about an organisation or event.

Sending a media release by mail, fax or e-mail is one of the most common methods a public relations practitioner uses to liaise with the media. It is worthwhile remembering that a media release should be well focused and have enough news value or points of interest to be turned into a news report or appear in a human interest or features section of publications.



Take note

The public relations practitioner should also remember that different media need different information and that each media release should be written and presented according to the specific needs of a medium. While radio does not need visual images, they may wish to use images as part of their social media feed. In contrast, photographs aimed at the community would be essential to include in a media release to the local community newspapers. Different visual images should be sent to different publications.

Structure of a media release

Media releases are usually structured in the same manner as standard newspaper articles. The information is presented in an inverted pyramid, descending in a logical manner from the most important to the least important information. The inverted pyramid writing style assists the public relations practitioner in getting the most important message across to the media.

Inverted pyramid

The inverted pyramid method is still widely used today by journalists, the media and public relations practitioners. It is a popular method because it tells readers quickly what they need to know.

The inverted pyramid structure can be described as follows.

- ▶ **The lead:** The first paragraph of a story is called the lead paragraph. This generally consists of new factual information that is the most important or the most interesting. The lead paragraph is therefore a critical paragraph. This paragraph must explain the 5Ws + 1H and should get your audience interested in reading more of the story. The next paragraph should develop the story in more detail.

- ▶ **Support and develop the lead:** Include any other important facts and information to support the facts provided in the first paragraph. Background information or quotes from credible sources can also be included in this paragraph.
- ▶ **Information in descending order of importance:** Other information of lesser importance can be included in this paragraph or in subsequent paragraphs.
- ▶ **Closing with a kick:** Nel (2005: 52) maintains that although an inverted pyramid structure assumes that the end of the story is the least important and can, if necessary, be cut, the ending need not be dull. Editors are becoming more sensitive to writing and will often work to cut other parts of the story, if length is a consideration, in order to keep a good ending. Closing with a kick can turn the inverted pyramid format into a champagne-glass structure, in which additional important information is imparted at the end.

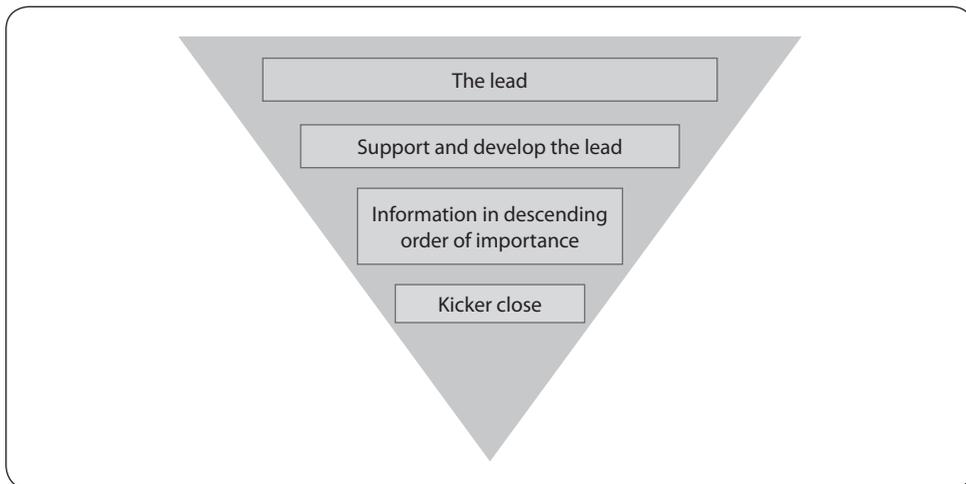

Figure 16.1 The inverted pyramid method of writing (Nel 2005: 90–92; 1994: 52)

Writing styles

One of the easiest ways of learning to write a media release is to study newspaper articles and to see how news stories are written. The most common writing styles are based on the 5Ws + 1H, SOLAADS and NIBSS methods.

5Ws + 1H

The 5Ws + 1H model of writing is a quick method for identifying the most important aspects in your story. For example, when writing your media release, ask yourself the questions: Who?, What?, When?, Where?, Why? and How? Figure 16.2 illustrates this writing model.

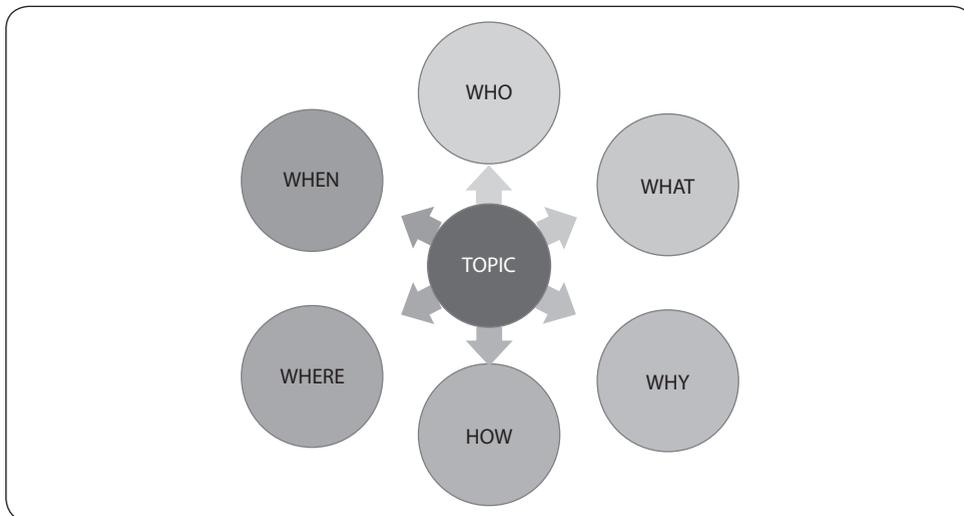

Figure 16.2 The 5Ws + 1H writing model

SOLAADS

Another good writing style is the SOLAADS method, proposed by public relations guru Frank Jefkins. Jefkins' (1994) formula is:

- ▶ **Subject** – what is the story about?
- ▶ **Organisation** – what is the name of the organisation?
- ▶ **Location** – where is the organisation located?
- ▶ **Advantages** – what is new? What are the benefits? What does the reader want/need to know?
- ▶ **Applications** – what are the uses? Who are the users?
- ▶ **Details** – what are the sizes, colours, prices, performance figures, distributors?
- ▶ **Source** – what/who is the source of the information and where can the journalist go to get more information or clarification? It is most important to put in direct-line phone numbers and cellphone numbers.

NIBSS

Public relations practitioner Ralph Cohen, in *The art and heart of communicating* (nd), suggests the NIBSS formula for selecting material for inclusion in a media release. NIBSS stands for:

- ▶ **N**ew information – this is the hard news
- ▶ **I**nteresting facts – this can be hard news, but more interesting
- ▶ **B**ackground – this is putting the story in perspective and providing details about the company/event
- ▶ **S**elling points – this is used especially for product releases to alert potential buyers to unique selling points
- ▶ **S**uperfluties – material that can be cut by the editor with no loss of meaning.



Example

Media release

The media release has a specific structure and format. While its style may vary from one organisation to another, a standard format can be used. The following media release layout and paragraph contents were adapted by Fielding and Du Plooy-Cilliers (2014: 312–313) from Nunes (2011):

(The slugline at the top right of the release helps to keep track of the press release during the editorial process. It is a brief word or two used to identify the broad topic. The number behind the slugline indicates the page number. With electronic copies and online releases now being used, sluglines are not frequently used.)

Tuesday, December 10, 2014 (This is the date on which the press release is written)

Slugline 1

RELEASE DATE/EMBARGO (This is normally 'FOR IMMEDIATE RELEASE'; if you want to hold the release until a specific date, you would write 'EMBARGO' and the date on which you want it to be released).

HEADLINE (no more than six words and no more than 60 to 75 mm deep)

Introductory paragraph should include all the important information and should always cover the 5Ws + 1H. Use the inverted pyramid or champagne-glass formula. Remember before starting your press release to set your margins to approximately 2.5 cm all around the page. This gives the editor enough space to make his or her own editorial notes. Use double-spaced type on one side only of an A4 sheet of paper.

Remember that each paragraph should not be longer than approximately six lines. It looks more legible if the page is *justified*. No fancy paper or artwork – plain white paper will do.

Justified: text aligns to the page margin on both the left and right hand side

The following paragraphs go on to explain the 5Ws + 1H in more detail. They usually start with interesting facts, then present background information and finally something positive. Be careful not to repeat information – rather elaborate, as a press release should be no longer than one and a half to two pages in length. Never use all capital letters as it is difficult to read and often viewed as rude – rather use upper and lower case type appropriately. The font size should neither strain the eye nor be too large. Stick to a point size of between 10 and 12.

When adding quotes to a media release, do not use jargon or any fluffy, boosting details. The media release should be a true representation of the news of the organisation. Always add the attribution to the quotes of the people mentioned in your story.

The last paragraph on the page should not be split. A new paragraph should be started on the next page. Indicate at the end of the page with the word 'more' so that the editor or journalist knows that there is another page to follow.

/more...

Slugline 2

Think of the way in which a real snail or slug leaves a trail everywhere it goes. This is effectively what a slugline does: it is a one-liner that leaves a 'trail' of the content of your press release for those you have sent it to. Each page gets its own slugline as an indication to the reader of the most important information on that page.

The last paragraph in your release should be a short synopsis of the organisation. Remember that this is not to 'sell' your organisation, but rather just to add to its credibility perspective. Remember to indicate the end of your press release by using the word 'ENDS'.

/ENDS

- ISSUED BY:
- Name of the person who wrote and sent the release
 - The job position that person holds, for example, Public Relations Practitioner
 - The company name
 - The company address
 - Relevant contact numbers (work line, cellphone, etc)

- CONTACT:
- Name of the person to be contacted if any further information is required (this may be the same as the person who issued the release or somebody else who will be able to provide relevant and accurate information)
 - The job position that person holds
 - The company name (if not the same as above)
 - The company address (if not the same as above)
 - Relevant contact numbers (please note that as much information as possible must be provided, including e-mail addresses, fax lines and social media accounts such as Facebook and twitter details)

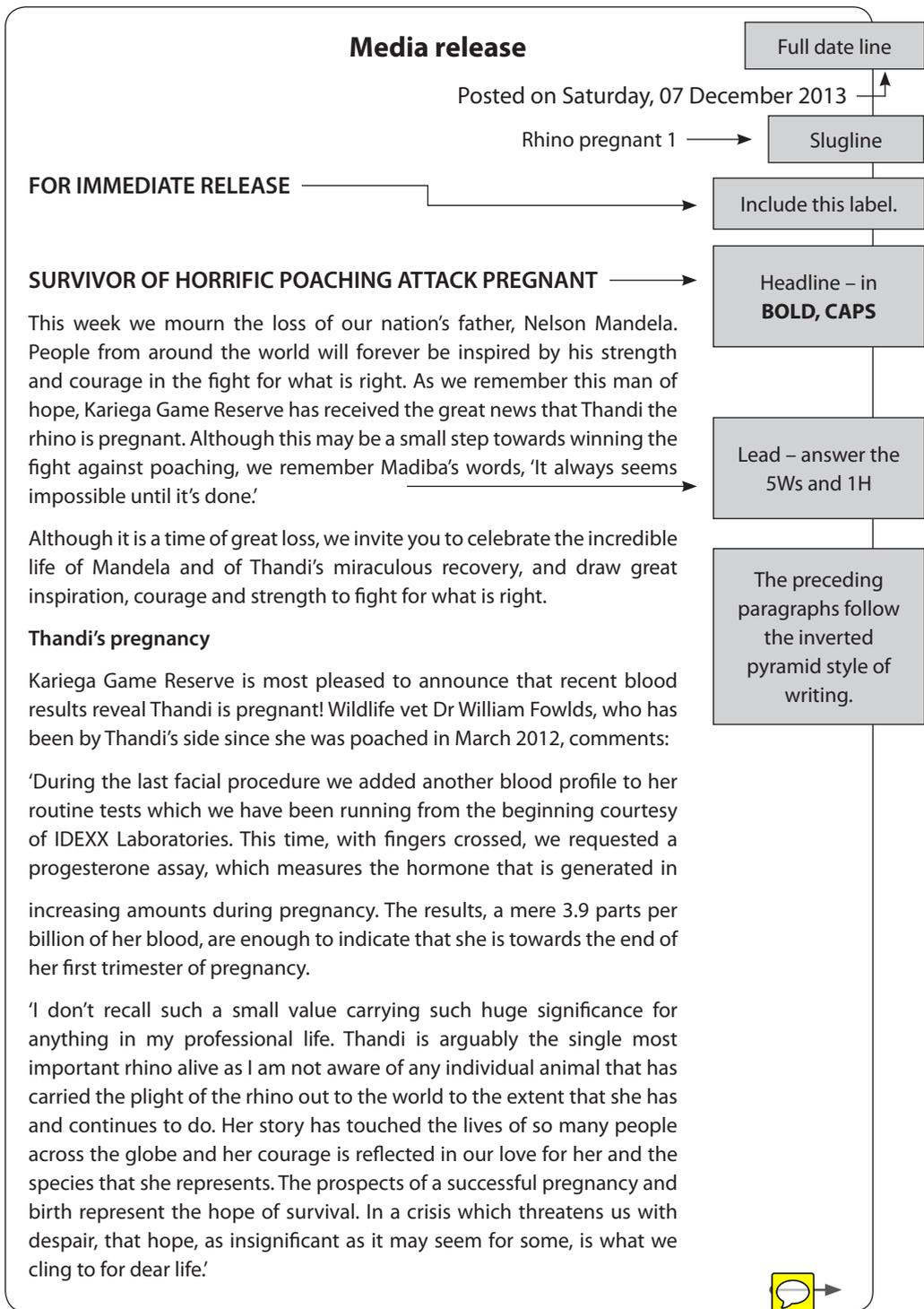

Rhino pregnant 2

Foundation patron and Kariega co-owner Graeme Rushmere comments:
 'This is incredible news, a real miracle if the tests are correct. Thandi having a calf will be a real reward for her courage and everyone's unbelievable efforts in saving her and hoping that she is able to lead a normal and peaceful rhino life after her horrific ordeal. She has been an amazing ambassador for rhino and for the many dedicated people fighting the war to end rhino poaching. We are simply delighted.'

ISSUED BY : Bronwen d'Oliveira
 Digital Communication Specialist

CONTACT: Bronwen d'Oliveira
 Digital Communication Specialist
 Kariega Game Reserve
 Eastern Cape
 e-mail: bronwen@kariega.co.za
 041-581-2606

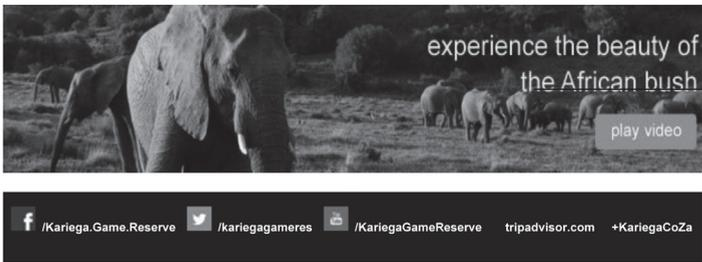

/ENDS. → Sluggine

The 'ends' marks the conclusion of the news release. Information below this is not intended for publication.

Information for the journalist, in case a follow-up is required. Make sure the contact details are correct.

Figure 16.3 Example of a media release

(Printed with permission from Kariega Game Reserve 2014)



Take note

See how social media networks are linked in the banner; also see the video link. When you click on these icons you will be directed to Facebook or Twitter, etc. The video link will take you on a virtual game drive at Kariega Game Reserve. Using these social media platforms in a media release can lead to more positive exposure of your organisation. A banner with a link to your social media platforms can be used with any online correspondence – especially with your e-mails.



Example

THE ANNOUNCER *Online*

Thandi, the rhino, is pregnant

Published On: Mon, Dec 9th, 2013

Local News/News



Thandi, the rhino from Kariega Game Reserve that survived a poaching incident, is pregnant

While the nation mourns the death of Nelson Mandela, the Kariega Game Reserve received the great news that Thandi, the rhino, is pregnant.

Although this may be a small step toward, winning the fight against poaching, staff at Kariega cited Madiba's words, 'It always seems impossible until it's done.'

At a time of great loss staff at Kariega celebrate the incredible life of Mandela and of Thandi's miraculous recovery, and draw from them great inspiration, courage and strength to fight for what is right.

Thandi's pregnancy

Wildlife vet Dr Will Fowlds announced the news of Thandi's pregnancy on Saturday after positive blood tests.

Fowlds said, 'During the last facial procedure we added another blood profile to her routine tests which we have been running from the beginning courtesy of IDEXX Laboratories. This time, with fingers crossed, we requested a progesterone assay, which

measures the hormone that is generated in increasing amounts during pregnancy. The results, a mere 3.9 parts per billion of her blood, are enough to indicate that she is towards the end of her first trimester of pregnancy.’

‘I don’t recall such a small value carrying such huge significance for anything in my professional life. Thandi is arguably the single most important rhino alive as I am not aware of any individual animal that has carried the plight of the rhino out to the world to the extent that she has and continues to do. Her story has touched the lives of so many people across the globe and her courage is reflected in our love for her and the species that she represents. The prospects of a successful pregnancy and birth represent the hope of survival. In a crisis that threatens us with despair, that hope is, as insignificant as it may seem for some, what we cling to for dear life.’

Foundation patron and Kariega co-owner Graeme Rushmere comments, ‘This is incredible news, a real miracle if the tests are correct. Thandi having a calf will be a real reward for her courage and everyone’s unbelievable efforts in saving her and hoping that she is able to lead a normal and peaceful rhino life after her horrific ordeal. She has been an amazing ambassador for rhino and for the many dedicated people fighting the war to end rhino poaching. We are simply delighted.’

Figure 16.4 The final newspaper report based on the media release in Figure 16.3

General writing tips

- ▶ It is crucial for your media release to contain newsworthy or noteworthy information to attract the attention of the media. Avoid writing the media release like an advertisement since this destroys the validity of the story.
- ▶ Use short paragraphs and keep your sentences simple.
- ▶ Aim for brevity; your media release should not be very long as journalists’ time is limited.
- ▶ Avoid using jargon and language that encourages cynicism in journalists, such as ‘the best’ and ‘world famous’. It is best to aim for an impartial, unbiased tone.
- ▶ Include a quote from a source related to the story, but only if the quote is original and adds value to the media release.
- ▶ Carefully proofread and spell-check your media release. You will lose credibility if your media release is littered with spelling and grammatical errors.

- ▶ Avoid using the same media release for all journalists. Try to write different versions of the media release for different media publications, for example, a local newspaper and a national newspaper. For radio, keep your media release short – between 60 and 100 words.
- ▶ The headline or the heading of the media release should grab the attention of the editor. It should summarise the main ideas of the media release, but in a way that is exciting and dynamic. Remember, you have just a few words to make your release stand out from the many others editors receive. It should always be in capital letters.
- ▶ Subheadings are generally unnecessary and should be avoided.

Online writing tips

Schwartz (2013) explains that the increase in digital media has not made the media release go out of style. Instead, with the increase in the choices people have and their access to bite-sized chunks of media via digital channels (think of a 140-character tweet), good media-release writing has become critical if you want your information to be published.

While online writing has many features that are the same as traditional news writing, there are areas that you need to keep in mind when writing news for an online medium. Dube (2014) shares 12 online writing tips that could help you with your online writing:

1. **Know your audience** – online readers skim and do not spend large volumes of time on one online space as a general habit. Make sure you write with the habits of the targeted online audience in mind. Research this for each platform that is specific to each target audience.
2. **Think first and think differently** – start by thinking about how you want to tell the story. With online writing there are so many additional tools and interactive applications that you can use to tell your story and engage your reader.
3. **Tailor your news-gathering** – when interviewing and writing for online media, to tailor your interviews and story to the online platform for which you are writing. Think, for example, of the video and audio interactions that could work best with your story and how you could use interviews to suit the medium best.

4. **Use lively, tight writing** – writing for the web is a hybrid of broadcast and print writing. It needs to be tighter and catchier than print, but needs more detail and depth than broadcast. Your online writing needs to be unique. In print, for example, people who have bought a newspaper and find a story that is not written in a manner that appeals to them have already purchased the paper. They are unlikely to rush out and purchase another paper because the story did not appeal to them. With online writing, however, readers can select another writer who is saying the same thing with the click of a button and at no extra cost.
5. **Explain** – people want to know what happened and why. Just because online writing happens in real time does not mean people don't want an explanation.
6. **Never bury the lead** – quickly tell the reader what the crux of the story is. If you bury the lead in your text, you will lose the reader.
7. **Don't pile the information on** – because online writing happens so quickly, online writers tend to keep putting the newest information on top of the old information. This creates a story that has information piled on top of information.
8. **Keep it short but sweet** – a good guide for online writing is no more than 800 words.
9. **Break it up** – in online writing, it is better not to have large paragraphs and masses of text, as this makes the text difficult to read onscreen. Rather use bullets and subheadings.
10. **Eliminate the guesswork** – headlines or links should give the audience a straightforward indication of what to expect.
11. **Do not fear the link** – use links in your story as long as they are focused and have a purpose.
12. **Take risks but remember the basics** – online writing is new and exciting and we are still creating a style guide for it. Changes happen and trends develop quickly in online writing, but it is important never to forget the basics of good journalistic and public relations from a traditional perspective.

There are many types of online writing that are important to public relations practitioners, such as website writing, social media writing and online media releases. One of the elements of online writing that is particularly complex and relatively new within the realm of public relations is social media. This is writing within a public relations context to serve the organisation. Kitanneh (2014) proposes that there are various ways in which an organisation can boost its social media footprint, usage and success. What follows is an adaption of some of Kitanneh's (2014) suggestions that will help you as a public relations practitioner to ensure that your social media strategy has focus:

1. Tweets must be able to catch your target audience's attention. Do this by customising your tweets' format. Use colour, a different font, etc.
2. Build Facebook groups.
3. Insert calls for action on your social media platforms. For example, have a button that allows people to vote for something, follow a link, etc.
4. Make sure that your interactions are meaningful.
5. Take some calculated risks and make sure your messaging is interesting and exciting.
6. Make sure that your messages, although varied, have focus and structure.

Online press rooms

Press rooms in the traditional sense were dominated by press kits. These were generally hard-copy files filled with printed copies of information that would be of interest to journalists about the organisation, such as media releases, biographical information, pamphlets, photographs, presentations, etc. They also often involved presentations or press announcements.

In the modern age, press rooms have moved into the online space where you can direct a journalist to an online portal that houses all the relevant news and information about your organisation. You can also set press rooms up with links and folders.

In the past, items such as press kits were extremely expensive: they were often printed in colour and contained photographs, PowerPoint presentations, biographical information, media releases, etc. There are lower costs involved in online press or media rooms, as they are called, because producing material with audio, visuals, colour, logos, etc, online does not cost the same as printing hard copies. It is also far more interactive than the traditional press or media room and you are able to do far more innovative and creative things with your information.

You would expect to find the following in an online press room (many of these are also found in traditional press rooms):

- ▶ Biographical information
- ▶ Media releases
- ▶ Audiovisual feeds
- ▶ Videos
- ▶ Events
- ▶ Company information and history
- ▶ Achievements
- ▶ Interactive forums.

Features

Features can be described as any editorial content other than news – material containing advice, comment, opinion, assessment, or subjective as opposed to objective news material (Hodgson 1993: 264).

Features, also referred to as soft news, differ from news reports as they are not written according to the inverted pyramid structure and the same emphasis is not put on the 5Ws + 1H. They are not time-sensitive like hard news and they allow the writer time to do in-depth research on the subject. The reader is provided with more detailed information. Features therefore tend to be longer than news reports.

Features do not have a standard structure, allowing the writer greater freedom. Their style is informal and they often start with a quote or a scenario. There are different types of features, each serving a particular purpose.

Types of features

News features

News features often appear in newspapers and focus on interesting or important background information relevant to topical news or issues. They are often written by experienced journalists and are usually situated on the page adjacent to the editorial comment page. Regular columns, depending on their content, can also often be considered feature articles.

Personality profiles

The personality profile is one of the most popular forms of human interest features. Personality profiles are written to bring an audience closer to a person. Interviews and observations, as well as creative writing, are used to paint a vivid picture of the person.



Example

Rap sensation DPoP was dressed in a NAIL Inc. designer outfit dripping in diamonds at the SA Artist of the Year Awards held at Star Hotel in Cape Town. DPoP posed for selfies with fans.

Human interest stories

A human interest story is written to show a subject's oddity or emotional or entertainment value. Human interest stories can be tragic, uplifting or simply bizarre.

Trend stories

A trend story examines people, things or organisations that are having an impact on society. People are interested in reading or hearing about the latest fads and trends, which makes such stories popular. Examples could include the latest fashion trends, a new religion or an increase in hijackings.

In-depth stories

An in-depth story provides a detailed account well beyond a basic news story or feature. It can be a lengthy news feature that examines one topic extensively, such as an investigative story that reveals wrongdoing by a person, agency or institution. An

example could be a story that exposes corruption and fraud by a government official.

Backgrounders

A backgrounder (analysis piece) adds meaning to current issues in the news by explaining them further. These stories bring an audience up to date, explaining how a country, organisation, person or situation got to be where it is now.

Writing and organising features

Feature writers seldom use the traditional inverted pyramid form; instead, they may write chronologically and build the story up to a climax at the end. Their stories are held together by a thread, and they often end where the lead started. Although there is no standard structure to follow when writing a feature, there are guidelines that may assist the writer in drafting the feature.

The lead pulls pieces of a developing puzzle together or spotlights a trend. A detailed backup paragraph or two supports the lead and gives evidence of the trend or development already highlighted in the lead. Thereafter, the story may be told in chronological order or in descending order of importance.

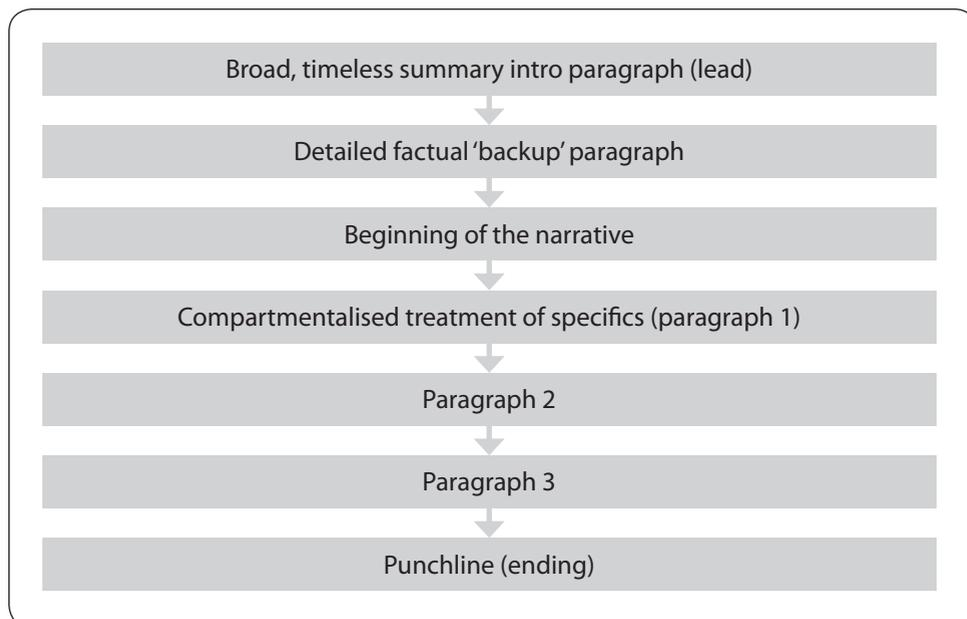

Figure 16.5 Guidelines for drafting a feature

The ending is very important in feature stories; unlike the inverted pyramid of the news report, the feature must end with some impact. Depending on the type of story, it can end with a quote, a 'moral of the story' statement, or even a joke.

Tips for writing features:

- ▶ Pick a theme.
- ▶ Write a captivating lead.
- ▶ Provide vital background information.
- ▶ Use clear, concise sentences.
- ▶ Use a thread to connect the different elements of the feature.
- ▶ Use transitional words to tie the paragraphs together.
- ▶ Conclude with a bang.

**Exercise**

Write a personal profile of yourself.

General articles

As the editor of an in-house publication, the public relations practitioner is often responsible for writing most of the magazine. This includes regular columns, comments on letters to the editor, general information, 'what's on', 'who's who', achievers of the month or year, etc.

The public relations practitioner may also be responsible for general articles used in the publications of sister companies, or articles to accompany media releases to specialist magazines. Apart from writing articles for publication, the public relations practitioner may also be responsible for generating information in monthly and annual reports, reports to shareholders, etc.

**Take note**

When writing any article, care should be taken to use good language, keep to the subject, avoid providing unnecessary information and, above all, to avoid using too many adjectives. Adjectives can easily frustrate the intelligent reader.

Light stories

Readers always appreciate a piece written in a lighter vein, provided it is tasteful and aimed at the right market. In-house publications can be brightened by a regular cartoon strip or a cartoon character that makes humorous comments about relevant issues. However, great care should be taken with light stories as some people might feel offended by them. They should always be in good taste and should never insult readers.

Captions

Information accompanying a photograph is called a caption, and its purpose is to add information. Photographs should not be used without captions.

Caption styles differ and they are written for different reasons. They are often written for photographs accompanying an article or news report. In other cases, the photograph is not accompanied by an article or story. Then the caption has to be written in such a way that it tells the story.

A caption for a group photograph of a new hockey team that accompanies an article should tell the reader who the team members are. Such captions are called identifiers.

In other situations, photographs may need supporting information, eg a photograph of a bereaved family. The family members appearing in the photograph must be identified, and information must be given about the deceased and the circumstances in which he or she died. This kind of caption is sometimes referred to as a self-contained caption.

When a photograph is not accompanied by an article or report, its caption should include more information than usual and will, therefore, be longer. For example: 'At a computer workshop in the conference centre, curious staff members listen to the advantages of the computer program that will, next month, replace the existing program. The workshop, presented by computer fundis, was organised after staff aired their concerns about the change.'

Guidelines for caption writing:

- ▶ Remember, the main aim of a caption is to add additional information to a photograph.
-

- ▶ Never state the obvious, ie that which is clearly visible in the photograph.
- ▶ Always write the first names and surnames (as far as possible) of people in photographs and their designation where applicable, eg Mr Toni Jones, managing director of Gold Fields South Africa (GFSa).
- ▶ Keep the purpose of the photograph in mind. You may wish to create an atmosphere of excitement, sadness, etc. Think of your caption story as a small introductory paragraph. Answer the 5Ws + 1H in three to four accurate, concise lines. When you write a 'caption story' for a photograph, try answering the most important 5Ws + 1H questions. Remember, there is no other copy accompanying the photograph.
- ▶ Do not refer to the photograph using phrases such as 'Here you see ...', etc.
- ▶ Captions will be influenced by the story accompanying a photograph. If the financial director comments on the budget, and a head-and-shoulders photograph is used, a very short identifying caption is sufficient. A short quote could also be used effectively.
- ▶ A good caption can enhance a fair photograph, but a bad caption can ruin a great one.
- ▶ Be meticulous about spelling names. It is extremely unprofessional to use a misspelled or incorrect name.
- ▶ Write your caption in the present tense, whenever possible.



Exercise

1. Find five newspaper photographs with their captions. Evaluate these captions according to the guidelines we have just discussed.
2. Find five newspaper photographs without their captions. Build your own story around the photograph and write a caption story for each.

Photographic pages

Photographic pages or spreads are an easy way to fill pages in a publication when news is scarce. Subjects or topics on which to build a photographic page are not hard to find and can include almost anything. Think of any recent developments, social functions, promotions, a sports day, etc. Each could provide enough photographic material to design a photographic page.

Every picture on the photographic page should have a caption – unless different pictures are used to illustrate something and need no explanation. Information might be given in a separate information block called a blurb.

A popular approach to photographic pages is to use a headline, an information block (blurb) to provide the necessary information, and a variety of photographs of different sizes and shapes with captions to tell the story.



Exercise

Compile a photographic page of yourself with at least eight photographs. Write a caption for each photograph and organise them so that they tell the story of your life.

Headlines

Writing headlines is not easy and is normally done during the subediting process by subeditors with many years' experience.

However, this should not stop the public relations practitioner from writing creative headlines to enliven articles.

Apart from headlines for in-house publications, the public relations practitioner may often be responsible for writing headlines for other purposes. How should this task be approached? The following guidelines should put you on the right track:

- ▶ A headline should fit the available space.
- ▶ Headlines attract attention. They must be brisk and attractive.
- ▶ Headlines must provide just enough information to make a reader curious. If a headline provides all the important information, the reader will not read the article.
- ▶ Headlines should be short and to the point.
- ▶ Present and future tenses must be used to create a feeling of relevance and newsworthiness.
- ▶ One-word headlines are acceptable but should not be used too often, eg 'Victory' when South Africa wins a World Cup.
- ▶ Headlines can be supported above or below by subheadings.
- ▶ Use verbs in headlines in the active rather than the passive voice, eg 'Bafana Bafana wins Africa Cup of Nations' is better than 'Africa Cup of Nations won by Bafana Bafana'.

- ▶ Do not use 'he' or 'she' in headlines. Rather: 'Postman saves drowning girl' or 'Robbers attack mother and baby'.
- ▶ In addition to these content guidelines, the physical appearance of headlines is just as important. Guidelines on physical appearance of headlines are followed by the layout artist according to the style rules of the publication, and include aspects such as size, typeface, fonts, right and left alignment, etc.
- ▶ Keep in mind that the two main functions of a headline are to draw the reader's attention to the story and to form part of the visual pattern of the newspaper page. (The latter is the task of the layout artist.)



Exercise

1. Find five news reports without their headlines. Read the content carefully and write your own headlines.
2. Find five news headlines and evaluate them according to the guidelines given above.



Summary

From the discussion in this chapter, it should be clear that a public relations practitioner has important writing responsibilities. Errors must be avoided at all costs as one cannot correct a mistake after publication.



Test yourself

1. List the different types of writing tasks that public relations practitioners are often required to do.
2. Explain what you understand by the term feature and describe the different types of feature articles.
3. What are light stories? How will you use them in your publication?
4. Describe different types of captions and give examples of each.
5. What does the term photographic page mean to you?
6. Briefly discuss the requirements of and the guidelines for writing headlines.
7. Identify the different writing styles that can be used to structure your media release.
8. Explain how the inverted pyramid structure is used to help you organise your media release.
9. Draft a media release using an appropriate style and format.
10. Write an executive summary for a company website.
11. Set up your own online press rooms.

Design and page layout



Objectives

After you have studied this chapter, you should be able to:

- edit copy and photographs
- do basic page layout by hand
- write and fit headlines
- understand what desktop publishing entails.

Introduction

Editing and *design* skills are of great value to public relations practitioners. A basic grasp of these skills not only gives you an edge when it comes to making final decisions on a publication, but also enables you to work according to set guidelines.

Responsibility for a publication encompasses the successful management of a range of activities. The result does not only reflect the degree of success of these activities – it also illustrates how the publishing process has been managed throughout.

In this chapter, we look first at what editing involves and then we focus on basic design and *page layout*. You may question the importance of manual editing and page layout when computer programs have become increasingly adept at fulfilling these tasks. The answer is simple. A computer program needs an operator. The operator responsible for page layout needs knowledge of design and layout principles and the skills to manipulate the computer program.

Editing: assembling, preparing, modifying or condensing copy

Design: the process of using different options to lay out or design a page

Page layout: the way in which printed matter is set out

A basic knowledge of page layout – the kind of knowledge that will guide you to maintain good balance on a page, use contrast and proportions effectively and achieve a visually attractive publication – cannot be obtained from a computer program. The foundation for these skills needs to be laid elsewhere. If an organisation has its own printing facilities, this lightens the public relations practitioner's burden in that changes, corrections and problems can be attended to quickly. If an outside printer is used, a print job is often more time-consuming as copy has to flow back and forth for editing and approval.

The guidelines in this chapter are scaled down to the very basics and are very broad. They focus on general needs arising out of various situations in which public relations practitioners may find themselves. In addition to internal and external house publications, public relations practitioners are often responsible for, or involved in, a variety of tasks, including editing articles and making final decisions on typography, paper, use of photographs, etc.

Basic journalistic skills are adapted to the needs of the public relations practitioner.

What does editing involve?

Editing is the process in which the subeditor (or editor in the case of many in-house journals) checks all the available material in the process of getting everything print ready. This process involves several tasks such as editing copy, pictures and captions. The subeditor is also responsible for writing headlines or editing existing ones for each story. Headline writing was discussed in Chapter 16.

Editing can be done electronically (on computer) or on printed (hard) copy. Let us look at the various editing tasks in more detail.

Copy-editing

Copy-editing involves two important functions, namely the editing of content and the editing of language and grammar. At daily newspapers, the responsibility of editing the content of news reports and checking the accuracy of facts and their legality rests with night news editors and night editors. Subeditors are responsible for checking language, grammar, spelling, etc.

When a public relations practitioner is the editor or subeditor of a publication, all of these responsibilities lie with him or her.

The public relations practitioner should first read the story to ensure that it has value for the publication and its readers. Although articles for such a publication will consist mostly of soft news and human interest stories, they must still be newsworthy – in other words, new, relevant, important or of interest to the readers.

Once the public relations practitioner is satisfied that an article can be used and the topic is appropriate for the readers and the publication, he or she checks the content for accuracy of names, dates, etc. Spelling, grammar and language are also checked and editorial comments are restricted to editorial articles and columns. The public relations practitioner also sees to it that sentences are short and to the point and that copy is written according to the organisation's house style. The story's sequence is also checked.



Take note

It is important to keep in mind that, although a subeditor's tasks on any publication are almost the same, style will influence the final product greatly. Articles for house publications differ from newspaper reports and are written in a more relaxed and informal style (rarely with 5Ws + 1H as points of departure).

Copy-editing includes editing the captions of photographs and this should be done with great care. Writing good captions is an art we elaborated on in Chapter 16.

When editing on computer, most editing tasks can be completed with little effort. There is no need to make use of the editing symbols needed for hard copy.



Take note

If the subeditor uses outside writers, layout artists or printers, he or she often has to work on hard copy using internationally recognised editing signs.

Write in the margin	Description	Example of sign used in the text
	Insert full stop	He was here
	Insert comma	...witness discover and enjoy.
	Insert apostrophe	Molly's second child
	Insert quotation marks	I refuse to do it!

EXAMPLE: COPY AS EDITED BY A SUBEDITOR

Figure 17.1 The most important editing symbols and an example of copy edited in this way (marked copy)

Picture editing

When editing pictures, there are several factors to keep in mind, including the content of the picture and its composition, balance and tone. The picture should be relevant to the story and it should also add balance to the page. The tone or contrast should be good enough to be satisfactorily reproduced (Hodgson 1993: 62–63).

Although photographs are usually edited during layout, this can also be done beforehand. Editing photographs for newspapers is usually left until the layout phase. This is the ideal time to decide which pictures to use and how much space to allocate to them.

However, when planning a magazine, editing photographs beforehand will not only lead to a better final product, but will also enable you to originate more or better photographs.

Cropping

There are two processes involved in picture editing, namely cropping and sizing or scaling. When cropping photographs, any redundant or unnecessary parts are marked on the back with a special marker. As certain markers are not permanent, cropping marks can also be made on the picture itself for removal after it has been used. Cropping a photograph will, to a large extent, determine the focus or focal point. The composition should not be disturbed by cropping and aspects such as space, thirds, background, etc, should be kept in mind.

An L-shaped piece of paper acts as a good guide in identifying unwanted parts of a photograph. You can block out sections with the L-shape positioned horizontally or vertically before making a final decision about which part to crop. One leg of the L-shaped template can also be used effectively. The two legs need not always be the same width.

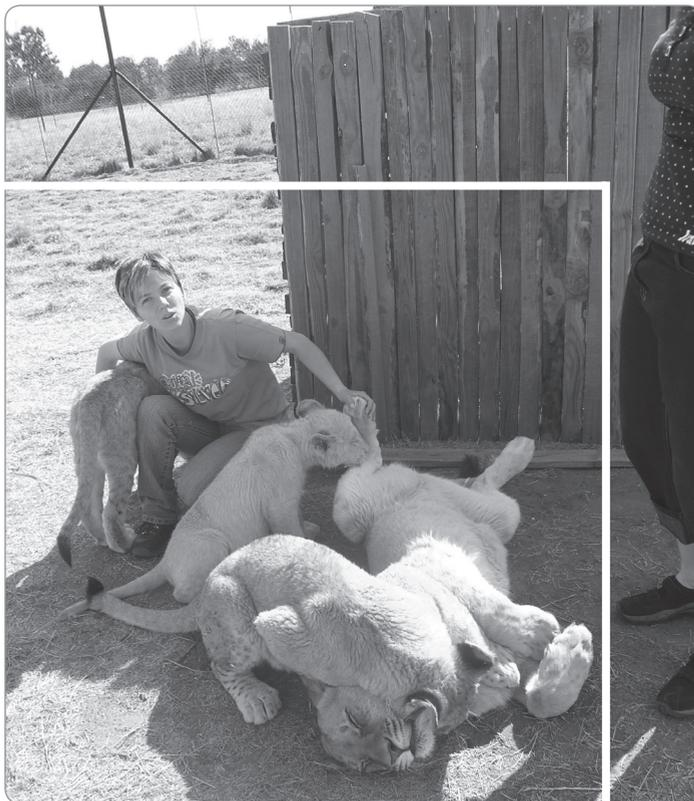

Figure 17.2A One way in which an L-shaped template can be used to eliminate wasted space



Figure 17.2B Another way in which an L-shaped template can be used to get rid of wasted space

Sizing or scaling

Once wasted space has been marked, the part of the photograph that will be used can be enlarged or reduced (sized or scaled) to fit an allocated space. This means that a relatively small head-and-shoulders photograph of an important person can be enlarged to almost double its size, depending on its quality. The better the quality of the photograph, the more you can enlarge it.

Before editing a photograph, its purpose in the publication should be clear. Sometimes it merely informs or lends visual appeal to the story. Both instances would apply in the case of a head-and-shoulders photograph of the MD or financial director accompanying an article commenting on a budget. On the other hand, a picture can tell its own story, eg a jubilant winning sports team. Editing is sometimes essential, eg where the background is unacceptable. A good picture should need no editing.

The process of scaling or reducing a photograph is very simple and can be done in the following way:

- ▶ Draw a light diagonal line with a pencil on the back of the photograph.
- ▶ Starting from the bottom corner where the diagonal line begins, measure a horizontal line (at the bottom of the picture) to the new, required width (eg two or three columns).

- ▶ Draw a vertical, dotted line from the new, required width until it intersects the diagonal line.
- ▶ Complete the exercise by drawing a horizontal, dotted line from the intersection.

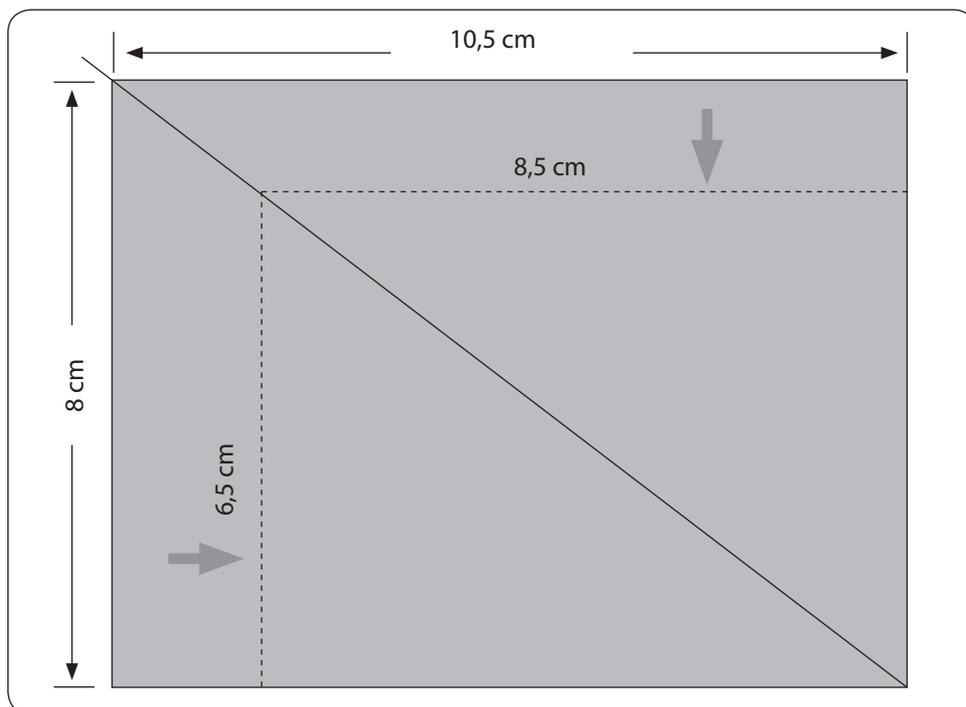

Figure 17.3 Reducing/scaling a photograph



Take note

The same procedure is followed when enlarging or sizing photograph. However, the photograph is then placed at the right, lower corner of a plain piece of paper. The required size can then be marked on the paper.

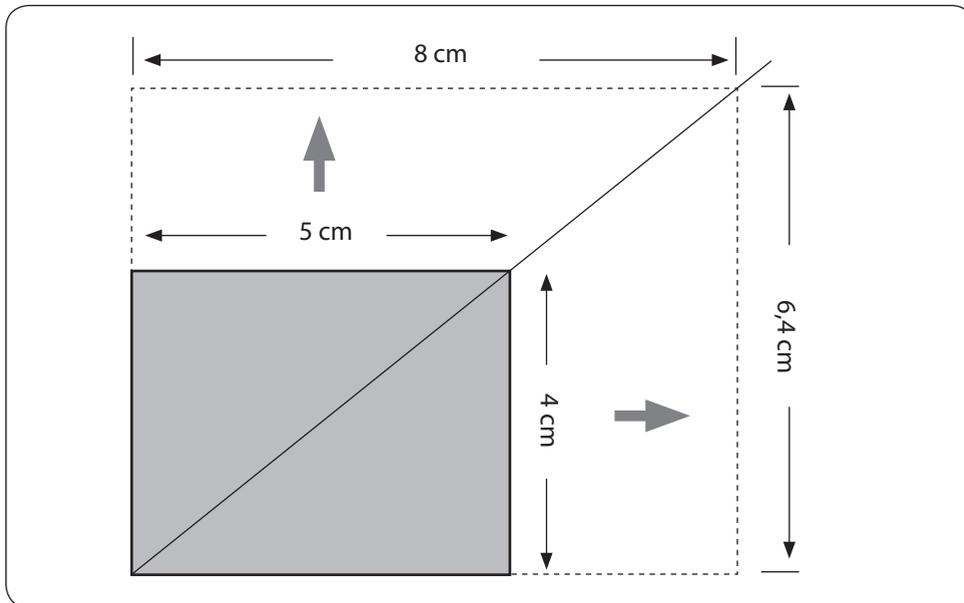

Figure 17.4 Enlarging or sizing a photograph

Approaching page layout

Page layout is an art. Although certain guidelines ensure a visually attractive publication, some of these guidelines are sometimes purposefully ignored by layout experts with interesting and positive results. Ignoring them altogether, however, often leads to disaster. The awful consequences become clear only when the publication is printed.

Page layout skills are essential to the public relations practitioner responsible for publications. Although different formats can be used for different publications, the same general principles apply to all of them. Simplicity is the layout artist's watchword – especially when working with smaller publications (in A4 or A5 format).

A basic knowledge of page composition – including aspects such as balance, contrast, proportion, proximity or unity, repetition or consistency and white space – is important to ensure a visually attractive publication. But what do these terms mean?

- ▶ **Balance** is the arrangement of the various elements on the page. Balance can be used to create a certain mood. For example, to create tension, one may throw elements out of balance. In order to balance a page, ensure that each portion of the design adds to the balance of the entire page. In practice, this means that balance refers to the way in which headlines, photographs and reports are used in relation to one another and to advertisements. Balance can be maintained in different ways. The traditional or conservative method is to balance the two vertical halves or the two horizontal halves of a page. The more modern approach allows for artistic freedom. Whatever the method, the result should always be a visually attractive publication with a definite focal point. The modern approach can also lead to stunning layouts in which the content and composition of a publication, ie sensational headlines, body copy and pictures, are intertwined to stimulate sales. Weekend newspapers, eg the *Sunday Times* and *Rapport*, often use this layout.
- ▶ **Contrast** occurs when two elements are different. In practice, contrast is achieved by using different typefaces; different sizes of typeface; large and small pictures; bold, medium and 'reversed out' headlines; horizontal and vertical reports; screens; borders; shades of colour; etc. Contrast makes different design elements stand out. The greater the difference between the elements, the greater the contrast. Using bold type is one way of creating contrast. Bold can be used to highlight or to emphasise important points. Another way to create contrast is to use different font sizes (larger) with a bold type (darker). This will assist in setting headlines apart from the rest of the text. However, remember not to overuse bold. For example, an entire paragraph in bold will make the text difficult to read.
- ▶ **Proportion** on a page refers to the extent to which body copy can be fitted into interlocking blocks of different sizes, differing in length and width. Newspapers seldom adhere to modular layouts as they become monotonous. Advertisements also preclude their use.
- ▶ **Proximity/unity** creates a bond between elements on a page. Every page should unify the copy, pictures, headlines and advertisements. The different pages of a newspaper should also form a stylistically coherent whole. To create

proximity/unity on a page and to ensure that your page looks organised, you need to space items according to their relation to one another. To create this, ensure that related items appear closer together than items that are not related. The reader will be able to use the spacing as a visual cue and to differentiate what is related and what is not.

- ▶ **Repetition/consistency** refers to the frequency of using design elements. Consistent use of type and graphics styles, and the repeated use of design elements, ensure that readers know where to go and helps them to find their way through the designs and layouts. Readers also become more comfortable when certain elements repeat themselves at consistent intervals. In practice, repetition can be created by using the same font for all headlines and the same graphic rule at the top of all pages in a multi-page document and by adding in repeated elements (like page numbers) in the same location on each page.
- ▶ **White space** refers to the absence of any text or graphics. This ensures that the page does not appear too cramped and also ensures easy reading and less confusion. If a page is too cramped, it becomes difficult to read.

All about typography

Typography: the style and appearance of printed matter

Typography plays an important visual role. There are many typefaces to choose from and incorrect choices can detract from a page’s visual appeal.

Typeface: a set of types or characters in a particular design

Typefaces can be divided into two categories: serif and sans serif. Serif characters vary in thickness of stroke and finish with a decorative tail (the serif). Sans serif letters are characterised by even strokes (Hodgson 1993: 46).

Serif	Sans serif
Times New Roman	Helvetica Light
Garamond Bold	<i>Helvetica Light Italic</i>
Palatino	Helvetica Bold
Century Schoolbook	<i>Helvetica Bold Italic</i>
Bookman	Avante Garde

Figure 17.5 Examples of serif and sans serif typefaces

Serif typefaces often used by newspapers include Times New Roman, Caslon Bold, Century Bold, Bodoni and Cheltenham. Popular sans serif typefaces include Gill Sans, Metro, Gothic and Helvetica.

Times Roman	<i>Times Italic</i>
Times Bold	Helvetica
<i>Helvetica Italic</i>	Optima
<i>Optima Italic</i>	Optima Bold
<i>Optima Bold Italic</i>	Helvetica Light
<i>Helvetica Light Italic</i>	Helvetica Bold
Helvetica Bold Condensed	Century Schoolbook

Figure 17.6 Examples of typefaces used by newspapers

A popular variation of the serif family, slab serif, differs slightly in that the serifs are squared. An example of slab serif is Rockwell (Hodgson 1993: 46–47).

Rockwell

Other typefaces that can be used effectively in public relations are Old English, Script and Novelty. These typefaces are characterised by their decorative appearance. They are often not very legible and are used mostly for purposes other than text, for example, on invitation cards, etc.

Brush Script

Zapf Chancery

Old English

The different typefaces can also be printed in *italic* (cursive), a sloping of the type to the right from the vertical position.



Figure 17.7 Examples of italic fonts

Typefaces can be used in different sizes, with variations in the height, width and weight of letters. All the different characters of one typeface in one size is called a *font*.

Let us look at the height, width and weight of letters.

Height

In addition to the normal height of a letter, the x-height is also important.

Because publications mainly use lowercase type, the height of letters is largely determined by the body height of lowercase letters, referred to as the x-height. The body of a letter excludes the ascenders, eg the upper parts of b, d, etc, and descenders, eg the lower parts of g, y, etc. The vertical measure of the body part (as in 'o' or 'u') is called the x-height.

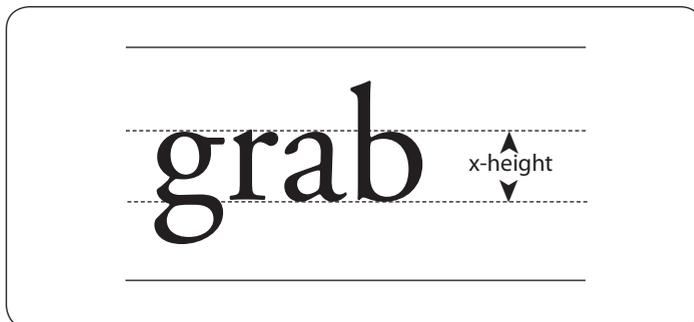

Figure 17.8 Measuring x-height

Although the x-height of different fonts will not affect the space needed for copy, it creates an optical illusion as seen in Figure 17.9.

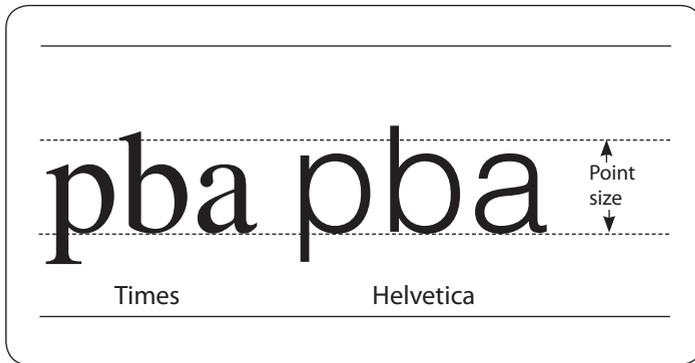

Figure 17.9 Comparing the x-heights of different fonts

Point size

The size of a letter is determined by the inclusion of both ascenders and descenders, and indicated in point size. Point size can vary from very small, eg 5-point, to very big, eg 72-point. The most popular size for newspaper copy is 10-point for body copy and 12-point for the introductory paragraph. Sizes from 18-point upwards are normally used for headlines. A 72-point headline might be used for a lead story.

Type width

Letters can be printed in condensed (narrower), normal or extended/stretched (wider) forms, although the normal format is used most frequently.



Figure 17.11 Examples of type width

Type weight

Letters can be set in light, normal and bold types. This refers to the thickness of a letter's lines. Body copy usually has a normal type weight, whereas headlines are often set in light and bold for contrast.

There are many options to consider when deciding on fonts and sizes. Consideration would always be given to enhancing the visual appeal of a publication.

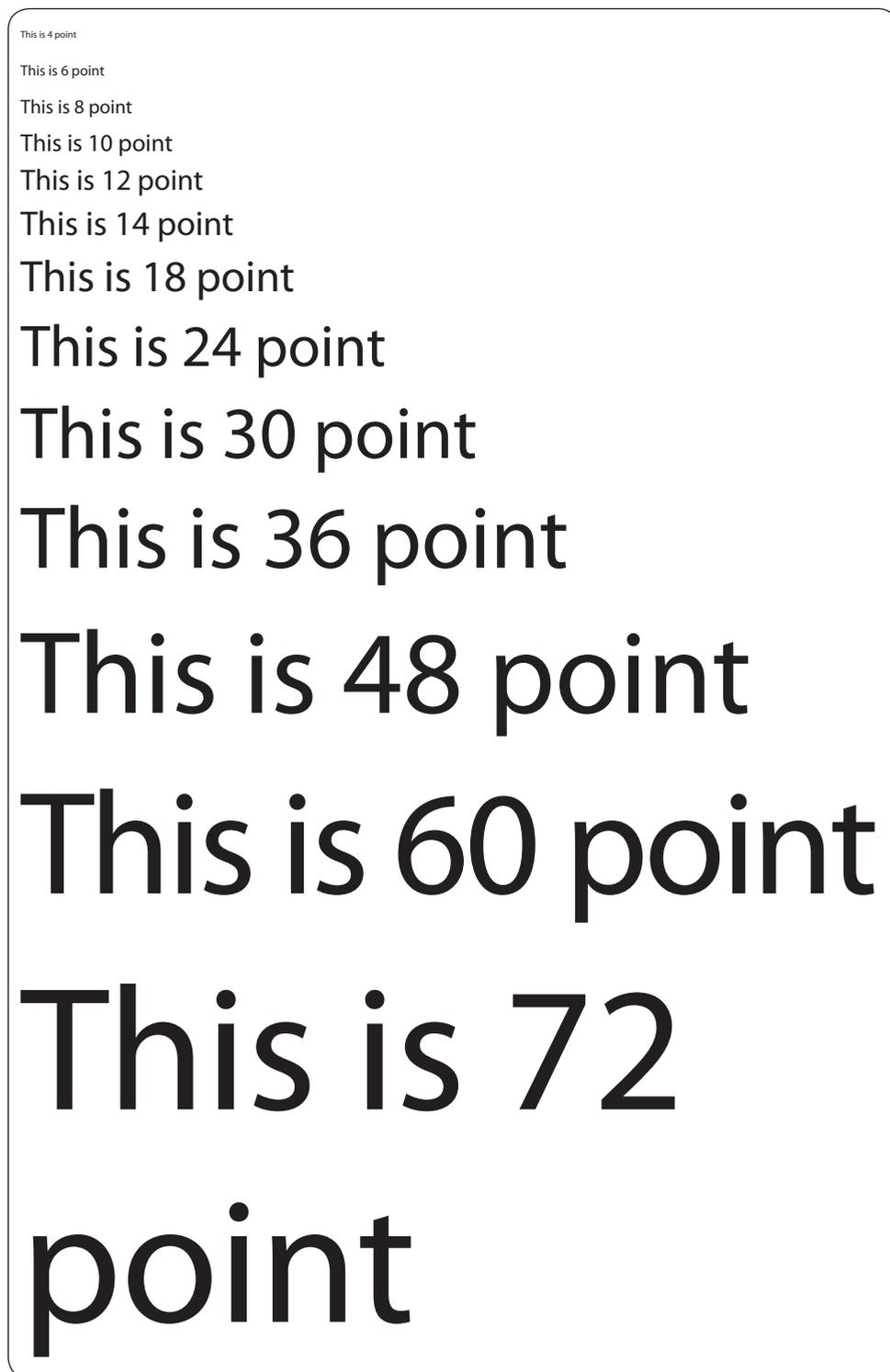

Figure 17.10 Examples of point sizes

Important aspects to bear in mind for layout

If you are an editor, it is your responsibility to ensure that you have enough material to use. Ensure, before deadline, that you have a suitable *lead story* for the front page. If you do not, make sure that you have some interesting stories or a new angle on an existing story, as you might need them unexpectedly.

Lead story: a story given the greatest prominence in a newspaper or magazine



Take note

It is important to delegate and manage responsibility in the layout process. When using outside print houses, determine the time they need to complete the job, exactly what they need from you and in what format. It is important not to be too adventurous. Rather play it safe by using familiar methods, choosing known typefaces, sizes, colours, etc.

A step-by-step guide to page layout

You have now gathered plenty of information and want to compile your publication. What do you do from here? The following steps suggest how the manual layout of a publication can be approached. These steps can be changed to suit different situations and needs:

- ▶ Select articles according to what can be used on which page.
- ▶ Choose a lively, colourful and captivating picture for your front page. Try to use a photograph or graphics on each page to add to its visual appeal.
- ▶ Fitting and sizing headlines form part of layout and must also be done during the layout process.
- ▶ Decide on the content for the front page first as this is the window of the publication and deserves the best material and pictures.
- ▶ Every page should be visually attractive. According to research findings, a reader's eye normally follows a reversed six pattern on a page. Try to fit the lead story of any page on the upper third of the reversed six.

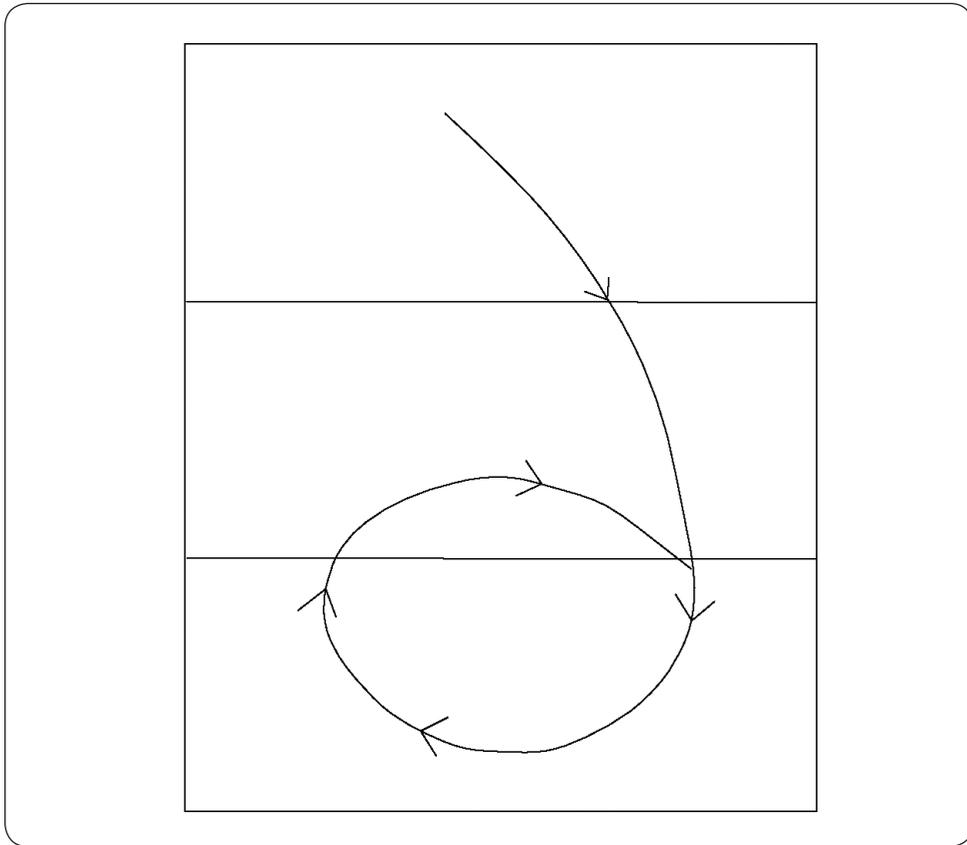

Figure 17.12 The reversed six layout pattern

Columns: the vertical, typed copy columns appearing on a page of a newspaper

If you are working to an A3 size, six or seven vertical *columns* are normally a good guideline to work on. Each column is approximately 39 cm long.

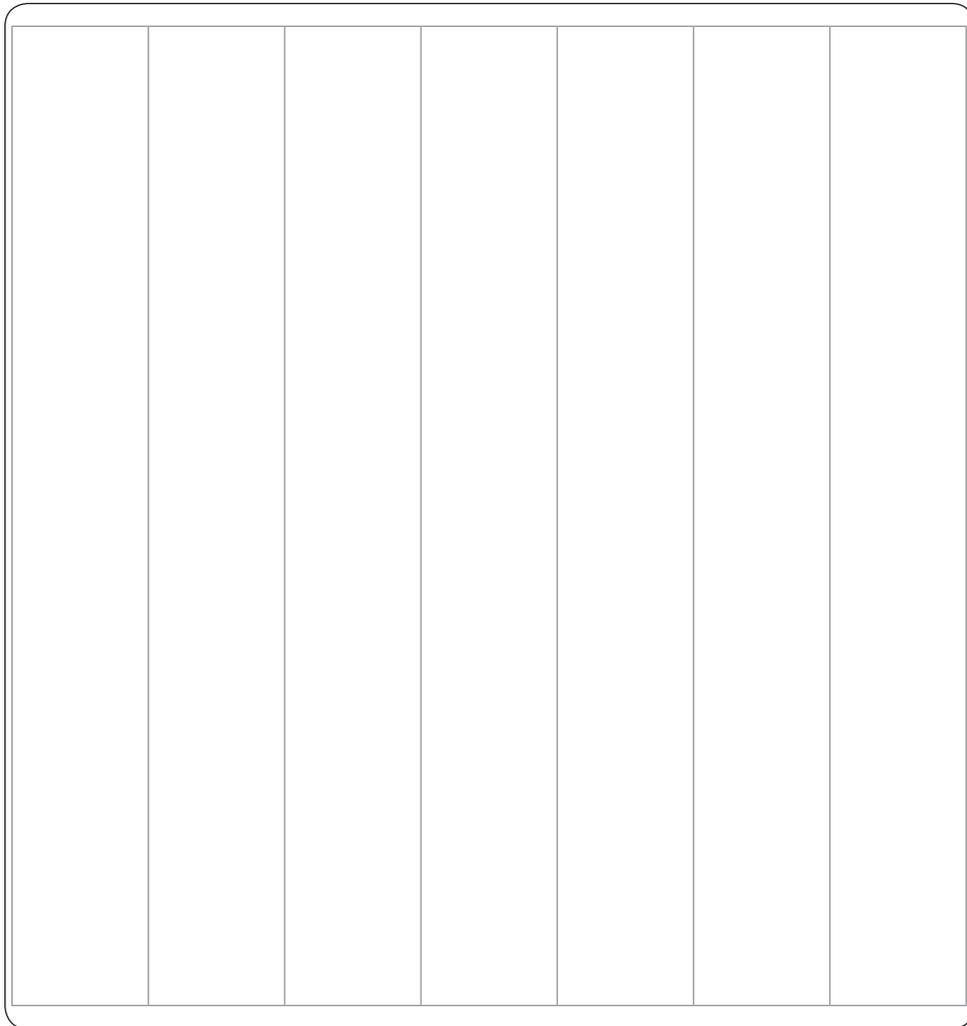

Figure 17.13 Example of page plan with seven vertical columns

Headlines

Headline writing was discussed in Chapter 16. Normally, headlines are written during the subediting process. In this section, we look at the many typefaces, letter sizes and weights that can shape headlines.

The use of different fonts for different purposes and decisions about size, weight, etc, can be simplified by keeping templates or examples of the sizes and weights of popular fonts in print.

This method is followed by many small community newspapers. As the space available for a headline may restrict your possibilities and word choice, it is advisable to complete the page layout first, allocate space to headlines and then write the headline according to the available space of your page plan. With practice, it becomes fairly easy to estimate the space needed for a headline, eg for the front-page lead story, the back page, etc.

Various ways in which headlines can be arranged in the available space

Let us look at how headlines can be arranged in the space allocated to them. Using a specific method often depends on house style, which usually determines the layout method used throughout the publication.

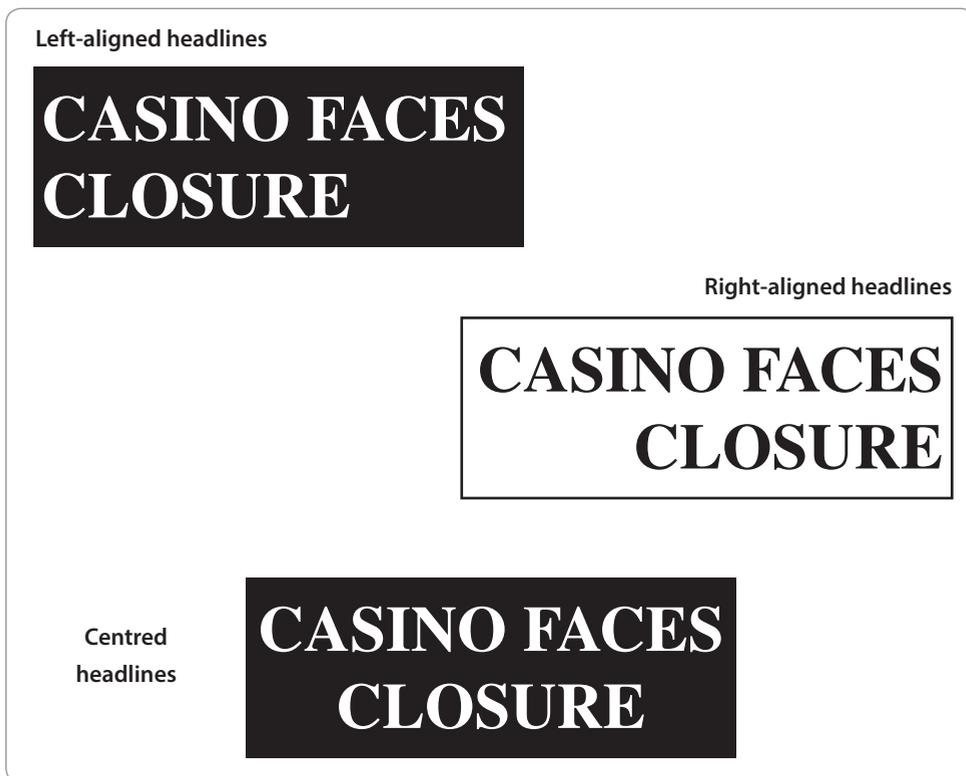

Figure 17.14 Examples of headline alignment

Using subheadings

A heading is often supported by a sub-headline or subheading that can be used above or beneath the headline. This gives more information about the topic.

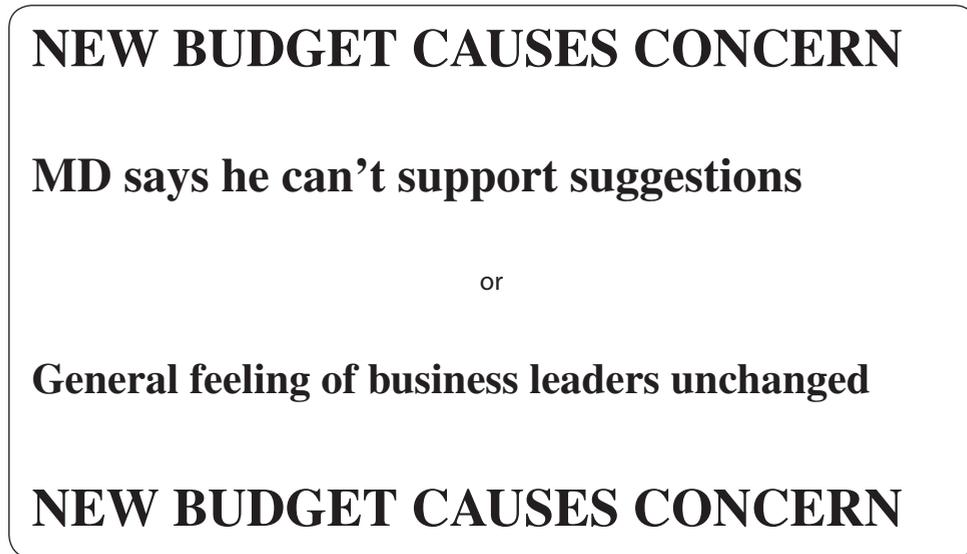

Figure 17.15 The use of subheadings

How to fit headlines into available space

Headlines can be fitted into the space allocated to them by using the typefaces in the style book and calculating the number of characters for each column.

Writing and fitting headlines is not an easy task and is only perfected through years of experience. At a daily or national newspaper, headlines are normally written by senior staff members with many years of experience.

There is a vast difference between the initial manual way of layout, in which the typefaces and specific fonts dictated the number of characters that could be used per column and the computer layout, in which the use of characters is much more flexible. For example, if a headline does not fit properly, various options, such as changing the font or typeface, changing the point (pt) size or stretching/compressing the headline could be exercised until perfection has been reached. Being able to achieve absolute precision and perfectly fitted headlines are some of the advantages of computer layout.

How to mark copy on the page plan

Copy is normally marked in on a page plan according to a set format. Let us assume we have selected the following material for our in-house publication's front page:

- ▶ a lead story about a possible merger with another company, plus a photograph of the two managing directors in conversation.
- ▶ a photograph of the winner of the recent Comrades Marathon, who holds a senior position in the company, crossing the winning line.
- ▶ a sidebar reading 'READ INSIDE'
- ▶ the publication's masthead, which runs across the page.

Considering the general rules of layout, we might lay out the page as follows:

- ▶ Mark in the masthead on the page plan.
- ▶ Decide where to place the lead story – remember, the upper third of the page attracts the eye first.
- ▶ Allow additional space for headlines.
- ▶ Arrange the lead story, photograph and headline so that they form a unit. The lead story must be easily identifiable.
- ▶ Mark in the photograph and its caption.
- ▶ Mark in the sidebar.
- ▶ Make sure that there is no unnecessary 'white space' left over.
- ▶ Work on the headlines – decide on the size, fonts, etc.
- ▶ Mark in instructions to the printer – circled so that the instructions will not be printed.
- ▶ Use a blue marker for photographs and a red marker for borders.

On page 264, there is an example of how the above rules might be applied for layout. Remember, there are several ways in which layout can be done.

Instructions to printers

Instructions on the page plan are important and should be clearly marked. They include the point sizes, borders, upper and lower case, pictures, etc. The marked page plan on page 264 is annotated with instructions to the printers.

Points to remember during layout

- ▶ Lead stories should be presented as lead stories! This can be done by allocating sufficient space to them and using a large typeface for the headline. A rule of thumb is to use larger headlines for important and long articles and smaller headlines for short and less important stories.
- ▶ Try to leave as little white space as possible.
- ▶ Although seven columns per page is a good guideline for an A3 page, this number is not mandatory and five or six vertical columns (which will be somewhat wider) can be just as effective. This is especially the case with A4 publications. Any number from two to five columns can be very effective.
- ▶ If your publication sells advertising space, remember that a specific space is sold at a certain price and that advertisements cannot be moved by the subeditor from the space allocated to them.
- ▶ Remember to allocate enough space for headlines.



Exercise

1. You are responsible for the front page of your company's A4-sized internal newsletter and decide to use the following material (draw only a rough 'dummy', presuming that this newsletter normally uses three columns per page and that the masthead covers approximately 20 per cent of the page):
 - a. a lead story with a head-and-shoulders photograph; and
 - b. an action photograph with a caption story.
2. Remember that you need to provide space for the masthead, a headline for the story and captions for both photographs.
3. It is presumed that the text for the lead story is too long and you have to edit it down to the required length or let the story flow over to another page.
4. Compare your effort with other existing publications.

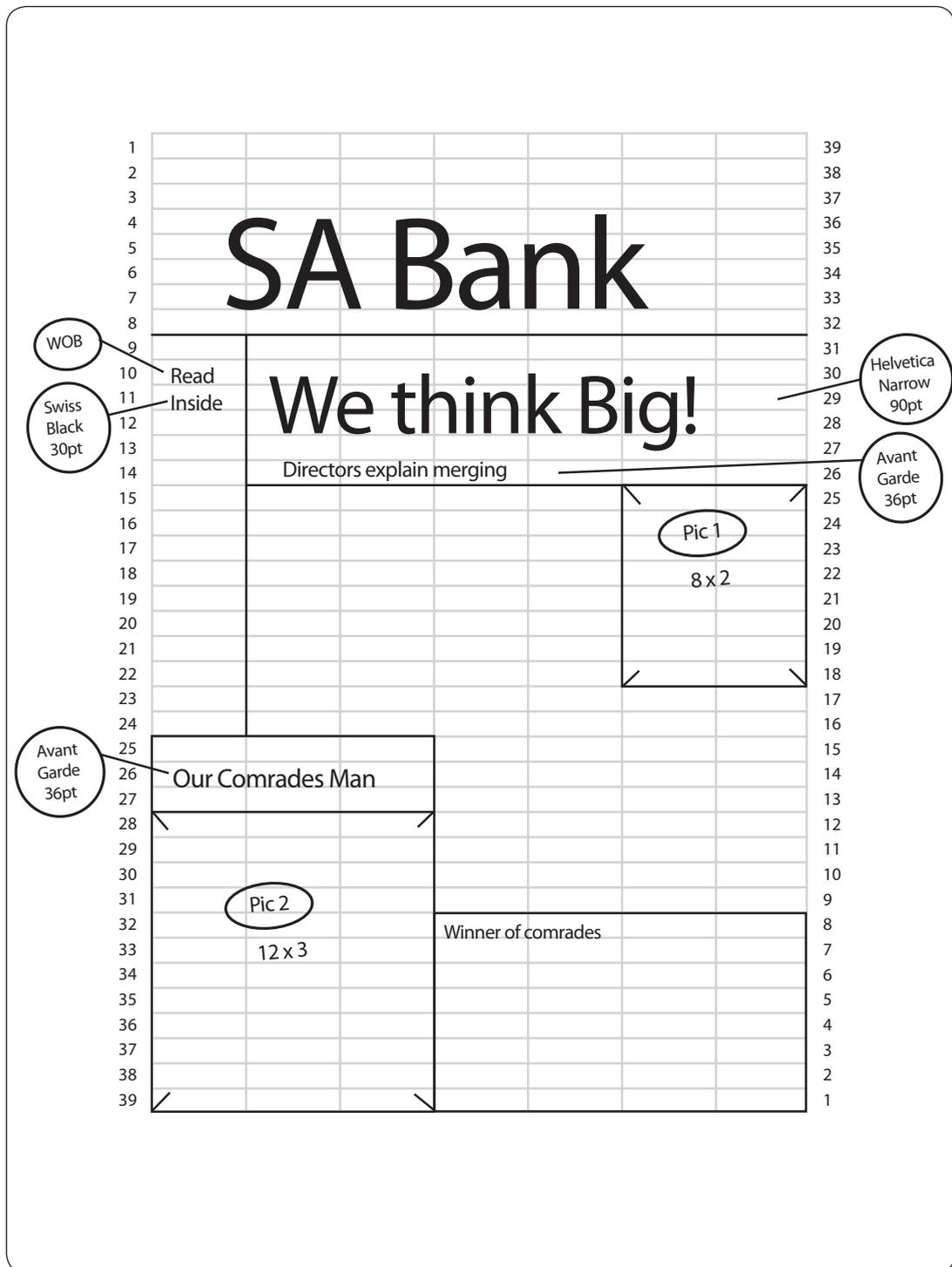

Figure 17.16 How to lay out a particular page using a page plan



Exercise

You are also responsible for the centre page of this A4 internal publication and decide to create a photo page with photographs taken at the recent open day at your company.

- Use two A4 pages, pasted next to each other to create the centre page.
- Draw in at least seven to nine picture blocks of different shapes and sizes in a visually attractive manner and write the contents of each picture inside the block.
- Now write appropriate captions outside the blocks in suitable spaces provided to accompany each picture.

Desktop publishing

At the beginning of this chapter, we briefly referred to the shift from manual to electronic page layout. We will now take a closer look at what this entails.



Take note

In addition to the equipment, training is an important prerequisite for DTP. Basic computer skills are not sufficient.

Electronic page layout on computer, known as desktop publishing (DTP), is the process of using the computer and specific types of software to combine text and graphics to produce documents such as newsletters, brochures, books, etc.

A DTP system allows you to use different typefaces, specify various margins and justifications and insert designs and graphs directly into the text' (Articlesbase.com 2010).

DTP is by far the most popular way to do page layout, not only because it results in a professional end product, but also because the right equipment and proper training save much time and effort.

It is important that public relations practitioners who are involved with internal or external publications should first ascertain what computer equipment is already available in their department and to what extent this equipment might be suitable for their specific needs. Smaller programs that might be suitable for a specific task can, for instance, be run on a personal computer, whereas larger

DTP programs may need more sophisticated equipment such as an Apple computer and/or networks.

Although there is no question about using DTP for regular substantial publications, the viability of electronic layout for any company and the equipment required should be researched thoroughly before any decisions are made.

Smaller organisations that do not wish to invest in expensive equipment can use the services of an outside layout artist and printer who will do the layout on a DTP program and submit it for approval. This could, however, be time-consuming and might not always lead to the end result envisaged.

What is needed for computer layout?

Certain basic equipment is needed for layout on a computer. Firstly, your existing computer has to have sufficient random access memory (RAM) to operate the program. You also need a Microsoft Windows or Apple operating system (the basic program that accommodates other DTP programs), enough storage space, a colour monitor, a mouse and a printer. There are various types of software page layout; programs available such as Adobe InDesign, QuarkXPress and Corel Ventura for professional page layout and Microsoft Publisher and Serif PagePlus for mid-level page layout; (Howard Bear nd). Seek professional advice when you choose between Mac or Windows platforms, and about the hardware you need for doing design and layout efficiently.

A scanner is also a good option if you often use photographs and have substantial publications. The software package (program) will depend on your specific needs. More sophisticated equipment, such as tools allowing you to draw your own graphics or do finer artistic work, is also available.

In bigger companies that work over a network, several computers can be used, enabling layout artists to work on different pages at the same time.

Computer companies normally provide excellent advice but always ensure that you clearly spell out your specific needs. There is a vast variety of equipment and software packages on the market and it is no use investing in the most expensive and advanced equipment if you are not going to use it to its

optimum. Also remember that training will be a necessity as this is a specialised field.

The team

Electronic page layout is unique in the sense that the end product is very much your own creation. A working knowledge of page layout will enable you to create a complete publication, from writing articles to finalising the publication and sending it to the printer. The exciting part of electronic layout is that you can use your own creativity in designing each page.

However, depending on the size of an organisation, there may be a team of people responsible for writing articles and an editor who will decide on a suitable lead story and the contents of each page. The editor will also indicate approximate sizes for stories and photographs. The layout artists, however, design each page allocated to them using the available material according to the style rules of the company.

It is advisable to have more than one person trained to ensure that deadlines are met and that there is always someone available to do the layout. In the case of regular publications, work is often divided between two to three people, each of them responsible for certain pages. It is the editor's job to do the final editing before the pages are sent to the printers.

The process

Much the same guidelines are followed for electronic page layout as described at the beginning of this chapter. Any publication is normally done according to a set of style rules compiled by the specific company or organisation.

Regular internal and external house publications have certain regular articles and columns and have specific spaces allocated to these, such as the editor's column, letters, cartoons, etc.

Electronic page layout has the advantage that a set of master pages or templates can be created beforehand and used for each subsequent edition of a publication. This means that there will be a ready-made front page, back page, general page, etc, that could be used as a basis from which to work.

Most DTP programs work with picture and text blocks, which means that once you have opened a page on your screen, you

first create picture or text blocks on the page and import the pictures or text from the central file server where they have been stored. An article that has been typed on another computer by somebody else and stored on the file server can be called up on the computer of the layout artist and imported into the text block that has been created on his or her page.

The same procedure is followed with photographs, which are scanned in using a scanner and stored on the file server. The layout artist will then create a picture block on his or her page on the screen and import the required photograph.

Once the required text and photographs have been imported, the layout artist must provide space for headlines and type them in. Different fonts and typefaces may be used for headlines, but most publications prefer only one or two, which they use in different fonts and sizes.

To fit headlines accurately, characters can be vertically or horizontally compressed or stressed or different typefaces can be used. If text and captions will not fit, you can either change the font size or increase or decrease the amount of horizontal or vertical space between items.

Typographic precision can also be obtained by adjusting the space between characters or lines, or by resizing the text boxes. Colour, shade and rotating lines, as well as text that runs around items and pictures, give many exciting options for the final look.

If you are not satisfied with the result, the page can be reduced to only 25 per cent of the screen and the space around the page used as a 'clipboard' where text and photographs can be moved temporarily to provide other options for the layout.

Editing of photographs provides many possibilities. Even bad photographs can be improved to better, interesting photographs by making use of some of the following options:

- ▶ applying colour and shade where necessary
- ▶ scaling, cropping, rotating or skewing the picture
- ▶ changing the standard picture-box shape to another picture-box shape
- ▶ applying background colour and shading
- ▶ applying frames/borders to picture boxes
- ▶ placing different images in one picture box.

The layout artist should also edit the contents of the text as he or she goes along – especially if the content is too much and should be cut or carried over to a following page.

However, good page layout on the computer only comes with experience. Newcomers in the field should keep the general guidelines of page layout in mind and keep it simple. Ideas on the computer screen may not always turn out so well in the final printed product.

Advantages of DTP

It is obvious from the above discussion that DTP holds many advantages for a professional end result. Once the system is up and running and people are properly trained, the process is also much smoother and faster than outsourcing the work. The list below details a few of the advantages of using DTP:

- ▶ There is more control over the way in which text is arranged and formatted.
- ▶ DTP can be used to bring lots of different files together in the same document.
- ▶ Do-it-yourself DTP can save money.
- ▶ It gives you complete control over your final product.
- ▶ It is easy to make changes.
- ▶ It provides more ways of communicating ideas effectively.
- ▶ Images can be imported into a DTP document from a scanner, graphics from a drawing package, frames from a video camera and text from a word processor (Articlesbase.com 2010).

The wrong equipment, inadequately trained people and expenses incurred by getting the system in place, however, can result in enormous costs.

Summary

A successful publication lies very much in the hands of the public relations practitioner's innovative ideas. To obtain the best results, your layout should be creative and original.



Test yourself

1. Reduce a photograph that is 12 cm wide and 10 cm high to 8 cm wide.
2. Enlarge a photograph that is 4 cm wide and 5 cm high to 8 cm wide.
3. Describe the difference between copy-editing and picture editing.
4. What do you understand by the term composition of a page?
5. Discuss the different typefaces and explain how they differ from one another.
6. Explain type width, weight and height.
7. Discuss the various ways in which headlines can be fitted to the space allocated to them.
8. Discuss the process and use of DTP.

Bibliography

Abbysguide.com. 2014. What is a digital camera? Available at: <http://www.abbysguide.com/digital-camera/guide/what-is-a-digital-camera.html>. [Accessed 12 July 2014].

Articlesbase.com. 2010. Desktop publishing (DTP) service solutions. Available at: <http://www.articlesbase.com/small-business-articles/desk-top-publishing-dtp-service-solutions-584926.html>. [Accessed 15 August 2010].

Bainbridge, WS. 2007. The scientific research potential of virtual worlds. *Science* 317(5837): 472–476.

Basic digital photography. 2014. Available at: <http://www.basic-digital-photography.com>. [Accessed 12 July 2014].

Bilbil, K & Sütçü, C. nd. *Functions of corporate web pages in media relations*. Available at: http://newmedia.yeditepe.edu.tr/pdfs/isimd_07/emel_karayel_bilbil.pdf. [Accessed 30 April 2014].

Biwalkar, M. 2013. Social media breaks barriers of communication within organisations. *The Economic Times*, 29 May 2013. Available at: http://articles.economictimes.indiatimes.com/2013-05-29/news/39602221_1_social-media-communication-platform. [Accessed 20 June 2014].

Botha, D, Chaka, M, Du Plessis, N, Krause, B, Rawjee, VP, Porthen, D, Veerasamy D & Wright, B. 2007. *Public relations: Fresh perspectives*. Cape Town: Pearson Education South Africa.

Business Dictionary. 2014. Internet. Available at: <http://www.businessdictionary.com/definition/internet.html>. [Accessed 13 July 2014].

Clayton, J. 1994. *Interviewing for journalists*. London: Judy Piatkus Ltd.

Cohen, R. 2007. Press release writing tips: 39 tips by Professor Ralph Cohen. Available at: <http://www.americanshakespearecenter.com/v.php?pg=184>. [Accessed 2 August 2010].

Contemporary Communications Inc. 17 February 2012. High resolution vs low resolution images. Available at: <http://ccideas.com/chatter/high-resolution-images-vs-low-resolution-images-a-short-primer-for-beginners/>. [Accessed 4 September 2014].

Curtis, A. 2011. Journalism and public relations compared. Available at: http://www2.uncp.edu/home/acurtis/Courses/ResourcesForCourses/PublicRelations/Journalist_vs_PR_Professional.html. [Accessed 28 March 2014].

Cutlip, SM, Center, AH & Broom, GM. 1994. *Effective public relations*. Englewood Cliffs: Prentice Hall, Inc.

Davies, F. 2008. Public relations and journalism: Truth, trust, transparency and integrity. Available at: ojs.lincoln.ac.uk/owps/article/view/3. [Accessed 28 March 2014].

Daye, D. 1994. *35mm camera handbook*. England: Bison Books Ltd.

De Beer, AS. 1998. *Mass media towards the millenium: The South African handbook of mass communication*. Pretoria: JL van Schaik (Pty) Ltd.

Dineva, I. nd. Is the social media revolution reshaping journalism? Available at: <http://www.firstpage.co.za/is-the-social-media-revolution-reshaping-journalism/>. [Accessed 28 May 2014].

Dube, J. 2011. Writing news online. Available at: <http://www.poynter.org/how-tos/digital-strategies/web-tips/13605/writing-news-online/>. [Accessed 20 July 2014].

Duncan, J. 2009. South Africa – migration underway, *beyond broadcasting: The future of state-owned broadcasters in Southern Africa*, edited by G Berger. Grahamstown: Highway Africa, pp. 43–54.

Elgie, B. 2012. Back to the PR basics: Working with the media. Available at: <http://bonnieelgiepr.com/blog/2012/09/12/back-to-the-pr-basics-working-with-the-media/>. [Accessed 30 April 2014].

Elgie, B. 2012. This September, let's get back to the PR basics. Available at: <http://www.bonnieelgiepr.com/blog/2012/08/29/this-september-let-s-get-back-to-the-pr-basics/>. [Accessed 30 April 2014].

Employees of Media24 and SABC.

Entrepreneur.com. 2004. Radio and TV advertising: Turn up the volume on your ad campaign by adding radio and television spots to the mix. Available at: <http://www.entrepreneur.com/article/21746>. [Accessed 19 September 2010].

eTV Press Office. 2014. Press Office. Available at: <http://www.bizcommunity.com/Press-Office/AboutUs.aspx?i=155163>. [Accessed 13 July 2014].

Evoque. 2013. *The impact of social media on modern journalism: Does your PR recognise it?* Available at: <http://www.evoquepr.com/2013/09/the-impact-of-social-media-on-modern-journalism-does-your-pr-recognise-it/>. [Accessed 18 July 2014].

Farberov, S. 2014. Psy's Gangnam Style makes Internet history by galloping past 2 BILLION YouTube views. Available at: <http://www.dailymail.co.uk/news/article-2644504/Psys-Gangnam-Style-hits-2-billion-YouTube-views.html>. [Accessed 9 September 2014].

Fielding, M & Du Plooy-Cilliers, F (eds). 2014. *Effective business communication in organisations: Preparing messages that communicate*. Fourth edition. Cape Town: Juta.

Free PR Advice. 2014. Available at: <http://www.free-pr-advice.co.uk>. [Accessed 11 July 2014].

French, J. 2014. Towers Watson research study on effective communication and ROI. Available at: <http://www.bizcommunity.com/Article/196/18/110632.html>. [Accessed 19 June 2014].

- Gibbon, T & Hawkes, R. 2008. Social media explained. *Admap* (490): 108.
- Grapevine Communications. nd The art and heart of communicating. Available at: <http://www.bizcommunity.com/PressOffice/PressRelease.aspx?i=273&ai=1787>. [Accessed 4 September 2014].
- Harrison, K. nd. Email is the key for pitching to media. Available at: <http://www.cuttingedgepr.com/articles/email-is-the-key-for-pitching-to-media.asp>. [Accessed 10 September 2014].
- Hausman, C & Benoit, P. 1990 *Positive public relations*. USA: Liberty Hall Press.
- Hodgson, FW. 1993. *Subediting: A handbook of modern newspaper editing and production*. Second edition. Great Britain: Redwood Books.
- Hough, GA. 1995. *News writing*. USA: Houghton Mifflin Company.
- Howard Bear, J. nd. Page Layout Software. Available at: <http://desktoppub.about.com/cs/basic/g/swpagelayout.htm>. [Accessed 4 September 2014].
- Hyde, SW. 1995. *Television and radio announcing*. USA: Houghton Mifflin Company.
- ICASA. 2014. About us. Available at: <https://www.icasa.org.za/AboutUs/tabid/55/>. [Accessed 13 July 2014].
- Jefkins, F. 1992. *Public Relations. M&E Business Handbook*. London: Pitman.
- Jefkins, F. 1994. *Public relations techniques*. London: Butterworth-Heinemann.
- Kaplan, AM & Haenlein, M. 2010. Users of the world, unite! The challenges and opportunities of social media. *Business Horizons* 53(1): 59–68.
- Kaul, V. nd. PR & The Media: Friends or Foes? Available at: [http://www.aiou.edu.pk/Media/Friends or Foe.html](http://www.aiou.edu.pk/Media/Friends%20or%20Foe.html). [Accessed 15 April 2014].
- Kelleher, T. 2007. *Public relations online: Lasting concepts for changing media*. California: Sage.
- Kietzmann, JH, Hermkens, K, McCarthy, IP & Silvestre, BS. 2011. Social media? Get serious! Understanding the functional building blocks of social media. *Business Horizons* 54(3): 241–251.
- Kittaneh, F. 2014. 11 unusual social media tips and tricks to drive branding, clicks and conversions. Available at: <http://www.entrepreneur.com/article/235596>. [Accessed 20 July 2014].
- Koonin, M. 2013. Managing risk, reputation and identity of young adults in a social media environment. *Online Journal of Communication and Media Technologies* 3(2): 75–93.

Lawton Communications Group. 2013. Social brands 100: The report. Available at: <http://www.socialbrands100.com/>. [Accessed 4 August 2013].

Le Roux, G. nd. Getting the picture. Available at: <http://www.prcentral.wordpress.com/tag/citizen-journalism/>. [Accessed 13 May 2014].

Lieb, R, Owyang, J, Groopman, J & Silva, C. 2012. The converged media imperative: How brands must combine paid, owned, and earned media. Available at: http://www.socialchorus.com/wp-content/files_mf/theconvergedmediaimperative120718121051phpapp02.pdf. [Accessed 4 August 2013].

Lieb, T. 2009. *All the news: Writing and reporting for convergent media*. Boston: Pearson Education.

Lloyd, L, Duncan, J, Minnie, J & Bussiek, H. 2010. *South Africa – Public broadcasting in Africa (AfriMAP 2010)*. Johannesburg: Open Society Initiative for Southern Africa. Available at: <http://www.scribd.com/doc/111566398/South-Africa-Public-Broadcasting-In-Africa-AfriMAP-2010>. [Accessed 19 September 2010].

Lubbe, B A & Puth, G. 1994. *Public relations in South Africa: A management reader*. Durban: Butterworths.

M-Net. 2014. History. Available at: <http://www.mnetcorporate.co.za/ArticleDetail.aspx?Id=82>. [Accessed 13 July 2014].

McLeod, D. 2014. New free-to-air rival for SABC, e.tv on the cards. Available at: <http://www.midrandforum.co.za/new-free-to-air-rival-for-sabc-e-tv-on-the-cards/>. [Accessed 2 September 2014].

Media Club of South Africa. 2014. South Africa's public broadcasting radio stations. Available at: <http://www.medioclubsouthafrica.com/component/content/article?id=120:-public-broadcasting-radio-stations>. [Accessed 13 July 2014]

MGI. 2012. The social economy: Unlocking value and productivity through social technologies. Available at: http://www.mckinsey.com/insights/high_tech_telecoms_internet/the_social_economy. [Accessed 3 August 2013].

Michelle 2012. *High Resolution vs Low Resolution Images*. Available at <http://www.ccideas.com/high-resolution-vs-low-resolution-images/> (Accessed on 20 July 2014)

Nation, C. 2014. Importance of external business communication. Available at: <http://smallbusiness.chron.com/importance-external-business-communication-19304.html>. [Accessed 19 June 2014].

National Association of Broadcasters. 2014. Broadcasting in South Africa. Available at: <http://www.nab.org.za/broadcast.asp>. [Accessed 13 July 2014].

Nel, F. 1994. *Writing for the media*. Cape Town: International Thomson Publishing Southern Africa.

- Nel, F. 2005. *Writing for the media in Southern Africa*. Third edition. Cape Town: Oxford University Press.
- Nel, F. 2005. *Writing for the media in Southern Africa*. Third edition. Cape Town: Oxford University Press.
- Newsom, D, Scott, A & Van Slyke, TJ. 1993. *This is PR: The realities of public relations*. California: Wadsworth.
- Niles, R. 2014. What is 'Journalism'? Available at: <http://www.robertniles.com/journalism/>. [Accessed 20 June 2014].
- OECD. 2007. *Participative web: User-generated content*. Available at: <http://www.oecd.org/sti/38393115.pdf>. [Accessed 27 July 2013].
- Pitter, K. 1998. *Every student's guide to life on the net*. USA: McGraw-Hill.
- Postman, J. 2009. *SocialCorp: Social media goes corporate*. Berkeley: New Riders.
- Pritchard, M. 2013. How social recruitment requires students to manage a responsible digital footprint. Paper delivered at the 18th WACE World Conference on Cooperative & Work-Integrated Education, Durban, 24–27 June 2013.
- Raffl, C. 2008. Assessing the impact of open content knowledge production in Web 2.0. *The International Journal of Technology, Knowledge and Society* 4(3): 83–92.
- Root, G N. 2009. Radio interview techniques. Available at: http://www.ehow.com/way_5201801_radio-interview-techniques.html. [Accessed 31 August 2010].
- SAARF. 2012. Latest news releases. Available at: <http://www.saarf.co.za/saarf/news-releases.asp>. [Accessed 10 July 2014].
- SABC. 2014. About the SABC – Press Releases: The new SABC TV Experience. Available at: http://www.sabc.co.za/wps/portal/SABC/SABCARTICLE?id=36b9b10044b9cb799c78bf69be1f1b5a&page_from=PRESS. [Accessed 2 September 2014].
- SABC. nd. SABC News Channel Packages. Available at: http://www.sabc.co.za/wps/wcm/connect/78f8118041bfee7491b6bdf6b9e85c6f/SABC+News+Channel+Package+Online.pdf?MOD=AJPERES&CONVERT_TO=url&CACHEID=78f8118041bfee7491b6bdf6b9e85c6f. [Accessed 2 September 2014].
- SABC1. nd. All you need to know about SABC1. Available at: <http://www.sabc1.co.za/sabc/home/sabc1/aboutus>. [Accessed 2 September 2014].
- SABC2. nd. What you need to know about SABC2. Available at: <http://www.sabc2.co.za/sabc/home/sabc2/sabc2aboutus>. [Accessed 2 September 2014].
- Schwartz, M. 2013. 5 tips to follow when writing press releases. Available at: <http://www.pnewsonline.com/water-cooler/2013/04/15/5-tips-to-follow-when-writing-press-releases/>. [Accessed 20 July 2014].

- Seitel, PF. 1995. *The practice of public relations*. New Jersey: Prentice Hall.
- Shure, S, Burnett, I & Brown, M. 2005. *A media guidebook for women: Finding your public voice*. USA: United States Agency for International Development (USAID).
- Skinner, C & Von Essen, L. 1995. *The handbook of public relations*. Halfway House: Southern Book Publishers.
- Skinner, C, Mersham, G, Von Essen, L & Motau, S. 2010. *Handbook of public relations*. Cape Town: Oxford University Press.
- Skinner, C, Von Essen, LM & Mersham, G. 2007. *Handbook of public relations*. Eighth edition. Cape Town: Oxford University Press.
- Solomon, S. 2013. Content enjoys a glorious reign. *Marketing Health Services* 33(2): 8–9.
- South Africa Online. 2010. Communications. Available at: <http://www.southafrica.co.za/about-south-africa/science-and-technology/communications/>. [Accessed 3 September 2010].
- SouthAfrica.info. 2012. South African radio online. Available at: <http://www.southafrica.info/about/media/streamingradio.htm#.U8JyYcuKDIU>. [Accessed 13 July 2014].
- SouthAfrica.info. 2013. The press in South Africa. Available at: <http://www.southafrica.info/about/media/news.htm#.U8ZwgZSSzHU#ixzz37dNVqoJC>. [Accessed 16 July 2014].
- SouthAfrica.info. 2014. Commercial radio stations in South Africa. Available at: <http://www.southafrica.info/about/media/861608.htm#.U8KhpcuKDIU>. [Accessed 13 July 2014].
- SouthAfrica.info. nd. South Africa's radio stations. Available at: <http://www.southafrica.info/about/media/radio.htm>. [Accessed 23 February 2010].
- Spencer-Thomas, O. 2013. News values. Available at: <http://www.owenspencer-thomas.com/journalism/newsvalues>. [Accessed 15 July 2014].
- Staff members from radio stations, SABC.
- StarSat. 2014. About StarSat. Available at: <http://starsat.co.za/about>. [Accessed 13 July 2014].
- Stokes, R. 2011. *eMarketing: The essential guide to digital marketing*. Fourth edition. Cape Town: Quirk.
- Television news editorial staff of the SABC.
- TNS. 2012. Social skills in the classroom: digital media use in Sub-Saharan Africa. Available at: http://www.tnsglobal.com/sites/default/files/whitepaper/TNS_In_Focus_digital_media_SSA.pdf. [Accessed 17 August 2013].
- Tarrow, S. 1999. *Media today: An introduction to mass communication*. USA: Houghton-Mifflin Company.

What is Journalism? nd. Available at: <http://www.careerqa.com/questions/what-is-journalism/>. [Accessed 20 June 2014].

Wilkins, E. 2013. The ultimate guide to content marketing & influencer strategy: How to build relationships & create content that drive business impact. Available at: http://traackr.com/wp-content/uploads/2013/06/Traackr_Ultimate_Guide_Content_Marketing_Influencer_Strategy.pdf. [Accessed 28 August 2013].

Willis, J & Willis, DB. 1993. *New directions in media management*. Massachusetts: Allyn & Bacon.

WisegEEK.com. nd. How do I become a journalist? Available at: <http://www.wisegEEK.com/how-do-i-become-a-journalist.htm>. [Accessed 7 August 2010].

WisegEEK.com. nd. What does a radio journalist do? Available at: <http://www.wisegEEK.com/what-does-a-radio-journalist-do.htm>. [Accessed 5 September 2010].

World Wide Worx & Fuseware. (2013).  *South African social media landscape 2014*. Available at: <http://www.worldwideworx.com/wp-content/uploads/2013/10/Exec-Summary-Social-Media-2014.pdf>. [Accessed 19 October 2013].

