

## COMBINED SPECTRAL SHAPING CODES AND OFDM MODULATION FOR NARROWBAND INTERFERENCE CHANNELS

K. Ouahada, H. C. Ferreira, A. J. H. Vinck\*, A. J. Snyders and T. G. Swart

*Department of Electric and Electronic Engineering Science, University of Johannesburg, South Africa*

*\* Institute of Experimental Mathematics, University of Duisburg-Essen, Germany*

**Abstract:** Distance Preserving Mappings is a relatively new technique finding its way to a wide use in the coding field. New codes mapping convolutional code outputs onto spectral nulls codewords have the purpose of generating a code with a certain spectrum specification and error correction capabilities, which can be exploited by the Viterbi decoder. Combining this class of new codes with an Orthogonal Frequency Division Multiplexing modulation scheme is actually a tool to reduce Electromagnetic Compatibility Interference in selected subbands or to cancel the narrowband interference potentially caused by, amongst others, high frequency radio transmissions. Taking into consideration the fact that a narrowband noise source is almost similar to a modulated orthogonal frequency division multiplexing carrier, and also the periodicity of the nulls in our spectrum, we are able to cancel the narrowband signal and its sideband interferences without using traditional techniques of cancellation, which is based on filtering. Shaping our spectrum at the transmitter is a technique, which can be exploited at the receiver to suppress any narrowband signal interference, which is regarded as noise. We will present in this paper the technique of cancellation and the coding gain that can be obtained when comparing to the uncoded data.

**Key Words:** Distance-preserving mappings, Spectral nulls codes, Spectral shaping codes, OFDM modulation, Narrowband interference.

### 1. INTRODUCTION

We will describe in this paper the construction of a new code by using the Distance Preserving Mappings (DPM) technique [1], here used to obtain Spectral Nulls (SN) codes that, when transmitted serially, will have a spectrum with zeros occurring at  $f = 1/kT$ , where  $k$  is an integer or a ratio of relatively prime integers.

We furthermore investigate the performance of this code when combined with Orthogonal Frequency Division Multiplexing (OFDM) modulation, which has proven its ability to deal with broadband frequency selective fading channels in wire-line and wireless communication systems. The creation of spectral nulls at certain frequencies is to achieve narrowband interference cancellation in order to minimize the problem of Electromagnetic Compatibility Interference (EMC), while also exploiting the favourable error correction capabilities of the code with spectral nulls codes (SNC). We have to control the spectrum of our transmitted data in such a way that we do not cause interference to other spectrum users, e.g. high frequency (HF) Radio.

It is important to mention that the use of the Fast Fourier transform (FFT) in the OFDM modulation

scheme will not allow us to switch off any of the affected subcarriers by the NBI, as a technique of avoiding the corruption of the data at that corresponding carrier, because of the strong link between the number of chosen carriers and the number of samples. This is why the FFT depends on the total number of subcarriers to achieve a very accurate transformation.

The paper is organized as follows: In Section 2 we present briefly the way of designing Spectral Nulls Codebooks. Section 3 introduces the technique of DPM as applied in the paper. The modified OFDM transmitter will be presented in Section 5. The cancellation and correction of the NBI results are in Section 6, and finally in Section 7 a conclusion of the performed analysis will be drawn.

### 2. SPECTRAL NULLS CODES DESIGN

The design of a baseband data stream with spectral nulls occurring at certain frequencies [2], is based on the consideration of the vector  $x = (x_1, x_2, \dots, x_M)$ ,  $x_i \in \{-1, +1\}$  with  $1 \leq i \leq M$ , to be an element of a set  $S$ , which is called the codebook of codewords with elements in  $\{-1, +1\}$ , here we represent  $-1$  as  $0$ , and the application of the Fourier transform to those

codewords, to get:

$$X(w) = \sum_{i=1}^M x_i e^{-j i w}, \quad -\pi \leq w \leq \pi. \quad (1)$$

Having nulls at certain frequencies is the same as having the power spectral density function equal to zero at those frequencies. This means that  $H(w) = 0$ , where

$$H(w) = \frac{1}{Mn} \sum_{i=0}^{M-1} |X^{(i)}(w)|^2. \quad (2)$$

It can be seen from Equation 2, that the power spectral density (PSD) depends on the frequency value. So we can design a codebook to generate nulls at certain chosen frequencies. Usually for simplification we present the codeword length,  $M$ , as an integer multiple of  $k$ , then

$$M = ks,$$

where  $f = r/k$  represents the spectral nulls at rational sub multiples  $r/k$  [3]. We have to satisfy

$$A_1 = A_2 = \dots = A_k, \quad (3)$$

where

$$A_i = \sum_{\lambda=0}^{s-1} x_{i+\lambda k}, \quad i = 1, 2, \dots, k. \quad (4)$$

If all the codewords in a codebook satisfy these equations, the codebook will exhibit nulls at the required frequencies.

The spectral nulls codebook for  $M = 6$  with  $k = 3$  and  $s = 2$  is:

$$C = \begin{pmatrix} 0 & 0 & 0 & 0 & 0 & 0 \\ 0 & 0 & 0 & 1 & 1 & 1 \\ 0 & 0 & 1 & 1 & 1 & 0 \\ 0 & 1 & 0 & 1 & 0 & 1 \\ 0 & 1 & 1 & 1 & 0 & 0 \\ 1 & 0 & 0 & 0 & 1 & 1 \\ 1 & 0 & 1 & 0 & 1 & 0 \\ 1 & 1 & 0 & 0 & 0 & 1 \\ 1 & 1 & 1 & 0 & 0 & 0 \\ 1 & 1 & 1 & 1 & 1 & 1 \end{pmatrix}$$

The power spectral density is shown in Figure 1.

### 3. DISTANCE PRESERVING MAPPING TECHNIQUE

Distance Preserving Mappings is a coding technique which maps the outputs of a Conventional Convolutional Code (CCC) onto other codewords, which can be either binary or non-binary [4], from a code with lesser error-correction capabilities. The purpose behind this technique is to firstly obtain suitably constrained output code sequences and secondly to exploit the error

correction characteristics of the new code with the use of the Viterbi algorithm [1]–[5].

The mapping table in Figure 2 maps the output binary  $M$ -tuples code symbols from an  $R = m/n$  convolutional code into binary  $M$ -tuples, which in this paper are codewords from a spectral nulls codebook. To illustrate this idea, we first present an example. We use the simple, “generic text book example” four state, binary  $R = 1/2$ ,  $v = 2$ , convolutional code with octal generators 5 and 7 [6]. At the output of the encoder, we can map the set of binary 2-tuple code symbols,  $\{00, 01, 10, 11\}$  onto a set of  $M$ -tuples spectral nulls code words, whether they are binary or non-binary codewords as will be explained in the following sections.

The property of distance increasing can be verified by setting up the matrices  $D = [d_{ij}]$  and  $E = [e_{ij}]$ . Here  $d_{ij}$  and  $e_{ij}$  are respectively the Hamming distance between the code words of the convolutional code and the mapper code, the latter is here the spectral nulls code.

In general, three types of DPMs can be obtained, depending on how the Hamming distance is preserved.

- In the case where  $e_{ij} \geq d_{ij} + \delta$ ,  $\delta \in \{1, 2, \dots\}$ ,  $\forall i \neq j$  we call such mappings *distance-increasing mappings* (DIMs).
- In the case where  $e_{ij} \geq d_{ij}$ ,  $\forall i \neq j$  and equality achieved at least once, we have *distance-conserving mappings* (DCMs).
- In the case where  $e_{ij} \geq d_{ij} + \delta$ ,  $\delta \in \{-1, -2, \dots\}$ ,  $\forall i \neq j$ , we have *distance-reducing mappings* (DRMs).

**Example:** We take  $\{010101, 101010, 011100, 100011\}$  as 6-tuples, which the corresponding state systems appearing in Figure 3. In our example we have:

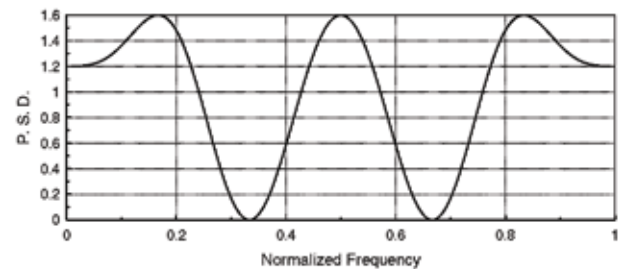

Figure 1: PSD of SN code for  $M = 6$  and  $k = 3$ .

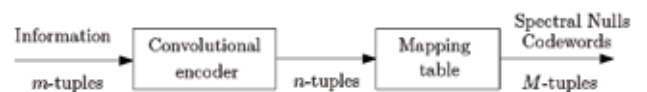

Figure 2: Encoding process for a distance-preserving spectral nulls code

$$D = \begin{bmatrix} 0 & 1 & 1 & 2 \\ 1 & 0 & 2 & 1 \\ 1 & 2 & 0 & 1 \\ 2 & 1 & 1 & 0 \end{bmatrix} \quad \text{and} \quad E = \begin{bmatrix} 0 & 2 & 4 & 6 \\ 2 & 0 & 6 & 4 \\ 4 & 6 & 0 & 2 \\ 6 & 4 & 2 & 0 \end{bmatrix}. \quad (5)$$

We can see that for all  $i, j, i \neq j, e_{ij} \geq d_{ij}$ . In fact, for  $i \neq j, e_{ij} \geq d_{ij} + 1$  and this guarantees an increase in the distance of the resulting code. The performances of the base code and different spectral nulls codes are compared in Figure 4.

As the mappings have changed the error correction performance of the resultant code compared to the base code, we can also see the change that happened on the spectrum of the code.

Figure 5 shows the spectrum of the DPM code and it is clear that the spectrum has changed compared to the original code, which is presented in Figure 1. Thus our mapping technique leads to a code with different spectrum and better error correction capability.

Finally we can say that changing the base code rate

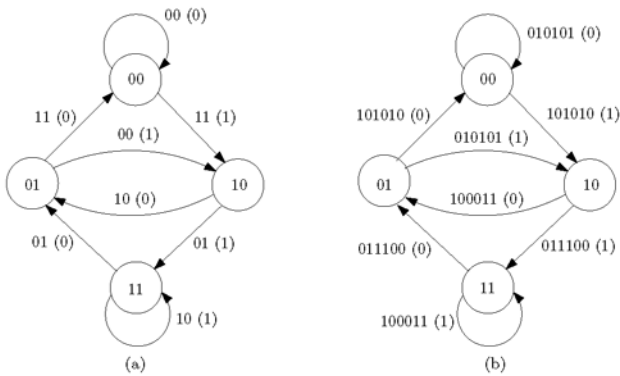

Figure 3: State systems for the (a) convolutional code and (b) DPM-SN code.

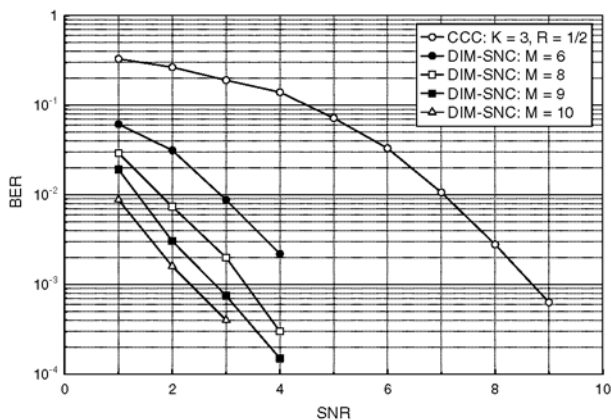

Figure 4: Hard decision decoding with QPSK/OFDM and AWGN.

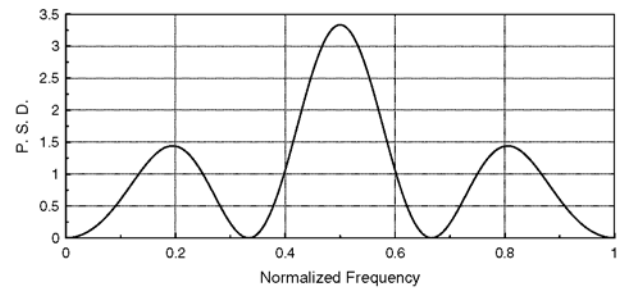

Figure 5: PSD of DPM-SN code for  $M = 6$  and  $k = 3$ .

Table I: Variation of Output Codewords

Convolutional Code Rate	Constraint Length K	Number of Output Codewords
1/2	3	4
2/3	4	8
3/4	5	16
4/5	7	32
5/7	7	16

to higher rates [7], will cover more codewords from the original codebook because of the increase in the number of outputs of the convolutional codes as depicted in Table I.

#### 4. OFDM MODULATION SCHEME

In this section we do not present OFDM in detail, which can be found in the literature. We will focus on two major properties of this modulation scheme, which are related to our technique of cancellation of the narrowband interference. We will discuss the serial to parallel (S/P) stage in the OFDM scheme and the orthogonality property of this modulation.

##### 4.1. Serial To Parallel

In the OFDM scheme and at the modulator we have to perform the IFFT operation to take the modulated data from the frequency domain to the time domain. The transmitted data, which is a sequence in the time domain reaches the OFDM modulator, where it will be presented in the frequency domain by the serial to parallel part in the OFDM modulation scheme as depicted in Figure 6. The loading technique of the information data into the OFDM sub-carriers bins is based on the type modulation technique that is chosen depends on the amount of data that we have to send. In our case we are using the QPSK modulation scheme [8]–[9].

##### 4.2. Orthogonality of the sub-carriers

The IFFT transform is a linear transformation, which maps the complex data symbols  $X(k)$ , with  $k \in \{0, 1, \dots, N - 1\}$ , to OFDM symbols  $x(n)$ , with  $n \in$

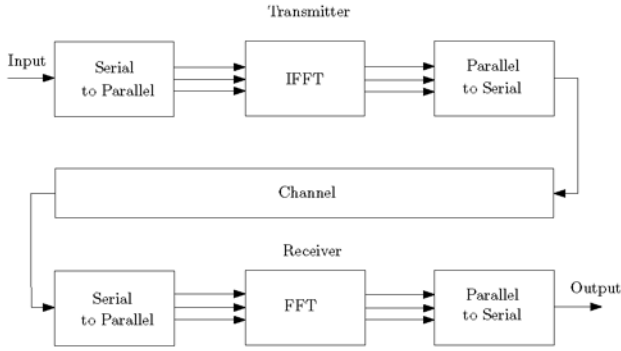

Figure 6: OFDM Block Diagram

$\{0, 1, \dots, N-1\}$  such that,

$$x(n) = \frac{1}{N} \sum_{k=0}^{N-1} X(k) e^{-j \frac{2\pi k}{N} n}. \quad (6)$$

The mapping linearity can be represented in a matrix form as:

$$x(n) = X(k) \times A_{\text{IFFT}} \quad (7)$$

where

$$A_{\text{IFFT}} = \begin{bmatrix} 1 & \dots & 1 & 1 \\ 1 & A & \dots & A^{N-1} \\ 1 & A^2 & \dots & A^{2(N-1)} \\ \vdots & & & \vdots \\ 1 & A^{N-1} & & A^{N(N-1)} \end{bmatrix} \quad (8)$$

with  $A = e^{-j \frac{2\pi k}{N} n}$  and  $k, n \in \{0, 1, \dots, N-1\}$ .

**Example:**  $N = 4$ ;  $x(n) = \frac{1}{4} \sum_{k=0}^3 X(k) e^{-j \frac{\pi}{2} kn}$ , with  $n \in \{0, 1, 2, 3\}$  with

$$A_{\text{IFFT}} = \begin{bmatrix} 1 & 1 & 1 & 1 \\ 1 & j & -1 & -j \\ 1 & -1 & 1 & -1 \\ 1 & -j & -1 & j \end{bmatrix} \quad (9)$$

and

$$A_{\text{IFFT}}^H = \begin{bmatrix} 1 & 1 & 1 & 1 \\ 1 & -j & -1 & j \\ 1 & -1 & 1 & -1 \\ 1 & j & -1 & -j \end{bmatrix} \quad (10)$$

and this leads to the fact that  $A_{\text{IFFT}} \times A_{\text{IFFT}}^H = NI$ , which means that the outputs of the IFFT transform are independent and the orthogonality of the OFDM modulation is always satisfied.

## 5. MODIFIED OFDM MODULATOR

As presented in the previous sections, we need to take our information data from serial to parallel (S/P) to load them onto the OFDM carriers and this is what is

called the serial to parallel step in an OFDM transmitter modulation scheme.

From the definition of the spectral nulls code and the algorithm of their construction, we can say that the designed codewords have specific patterns satisfying Equation 3, and their spectrum has nulls at the specific designed frequencies.

To explain this better, we suppose that a designed spectral nulls codebook  $S_N$  has a null at the frequency  $f_N$ . This means that the power spectrum density is zero at the frequency  $f_N$ . We can say that if we load these codewords from the codebook  $S_N$  onto a carrier with a frequency equal to  $f_N$ , we will have no power at that specific frequency. Thus these codewords should keep their pattern safe as it was designed to guarantee a null at the specific frequency.

From Figure 7 (a), we can say that the S/P step in the OFDM transmitter may disturb that pattern and then we will not be able to have the same sequence of data that will create a null at the specific frequency.

A modification to the OFDM modulator is necessary to overcome this problem. Figure 7 (b) shows the modified OFDM transmitter where an OFDM multiplexer is added and has the role of rearranging the data in such a way when loaded on carriers, that we can preserve the sequence and patterns of the spectral nulls data.

As example if we send the following data stream, which is generated from our spectral nulls codebook, **000111** **001110** **111000** **110001**, the OFDM multiplexer will arrange it as shown in Table II.

As we can see, our multiplexer arranges our data column by column from top to bottom and then read data out row by row from left to right (see the bolded-font bits).

We can see from Table II that the number of columns is equal to the number of carriers and with this way of rearranging our data, when we pass via the S/P stage in the OFDM, we will guarantee that our data loaded

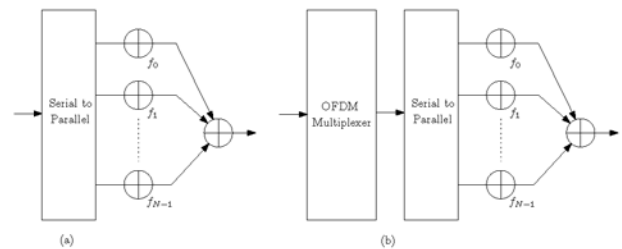

Figure 7: (a) Standard OFDM Modulator. (b) Modified OFDM Modulator.

Table II: OFDM Multiplexer

OFDM-Multiplexed Data				
	$cw_1$	$cw_2$	$cw_3$	$cw_4$
	$\mathbf{0}$	$\mathbf{0}$	$\mathbf{1}$	$\mathbf{1}$
Codeword	$\mathbf{0}$	$\mathbf{0}$	$\mathbf{1}$	$\mathbf{1}$
of length	$\mathbf{0}$	$\mathbf{1}$	$\mathbf{1}$	$\mathbf{0}$
$M$	$\mathbf{1}$	$\mathbf{1}$	$\mathbf{0}$	$\mathbf{0}$
	$\mathbf{1}$	$\mathbf{1}$	$\mathbf{0}$	$\mathbf{0}$
	$\mathbf{1}$	$\mathbf{0}$	$\mathbf{0}$	$\mathbf{1}$
Number of Carriers				

onto the carriers preserve the sequence of the designed codebook.

## 6. CANCELLATION AND CORRECTION OF NARROWBAND INTERFERENCE

### 6.1. Channel description for narrowband noise

The narrowband noise signal has an energy  $E_{Ms}$  and a frequency  $f_{Ms} = f_i$ , where  $f_i$  corresponds to one of the transmission frequencies. This energy exceeds the received power level by orders of magnitude. We assume that the narrowband noise source has the probability  $\rho_n$  to be present, and the duration will be for  $M \times t$  symbols, where  $t \in [0, \infty)$ . The assumption that the duration of the narrowband noise is a multiple of the duration of a codeword in our spectral null codebook is to simplify the problem. However, if asynchronous transmission is used, the duration of the narrowband noise disturbance is likely to exceed the duration of the transmission making the above assumption valid.

### 6.2. OFDM in the Presence of Narrowband Noise

Narrowband signals are considered to be approximately in the range of a single carrier [10]–[11]. The output energy of the narrowband noise source always exceeds the output energy of the modulator, which will cause the demodulator to have a consistent symbol that is *always on*, and this means that the outputs at the demodulator will be saturated to the maximum value of energy as we will prove in the following proposition.

**Proposition:** *The presence of a narrowband signal causes the saturation of the energy at the corresponding single carrier.*

*Proof:* To simplify the concept we suppose that no multipath channel exists, so we consider our channel as the combination between the AWGN (GN) channel and the Narrowband noise (NBN), so the transmitted data  $X_{tx}$  will be affected by both noises and the received data  $X_{rx}$ , will be:

$$\begin{aligned} [X_{rx}] &= [X_{tx}] + [GN] + [NBN] \\ &= [X_{(tx+GN)}] + [NBN] \end{aligned} \quad (11)$$

We can see that the term (NBN) contributes to the received modulation symbols of all subchannels as a second noise besides the additive Gaussian noise.

Taking into consideration the linearity of the FFT/IFFT transform we can apply this property to Equation 12:

$$\begin{aligned} \text{FFT}(X_{rx}) &= \text{FFT}([X_{tx}] + [GN] + [NBN]) \\ &= \text{FFT}(X_{(tx+GN)} + NBN) \\ &= \text{FFT}(X_{tx+GN}) + \text{FFT}(NBN) \end{aligned} \quad (12)$$

Considering the narrowband noise as a single OFDM subcarrier, will give this noise the sinusoidal form and by looking at the spectrum of this narrowband noise after applying the Fourier transform  $\text{FFT}(NBN)$  as presented in Equation 12, we can say that we get an additional pulse presented by additional energy to the received signal at the corresponding subcarrier and this will cause the received data at the demodulator to be *always on*, which means we get the all “000...000” or “111...111” codewords, depending on the length of the codewords of the original spectral nulls codebook as explained previously.

### 6.3. Detection and cancellation of the narrowband interferences

#### Detection of the NBI:

Designed spectral nulls codebooks contain the codewords  $\overbrace{00\dots0}^M$  and  $\overbrace{11\dots1}^M$ , so to be able to trace and detect the NBI, we design a coset of the spectral nulls codebook, which does not contain these two codewords. We only chose our mapping codewords from this coset to avoid having  $\overbrace{00\dots0}^M$  and  $\overbrace{11\dots1}^M$  and this make it clear and easy to detect the presence of a NBI.

At the demodulator we have to add a Power Spectrum Density (PSD) detector or a NBI detector such as in [11], which can detect the disappearance of the Nulls at the specific frequencies caused by the appearance of the NBI. Figure 8 shows the modified demodulator where a PSD detector is added.

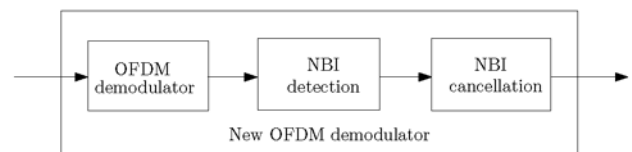

Figure 8: New OFDM Demodulator.

*Cancellation of the NBI:*

The cancellation step comes after the detection of the NBI as shown in Figure 8. Canceling narrowband interference by creating a null at the corresponding frequency is the same as having the sequence of our codewords with the same patten of a designed spectral nulls codewords at the specific frequency.

At the demodulator, the data will be located in the time-frequency grid, which is similar to a matrix with the number of rows equal to the number of carriers. Once we have located the all zeros or ones cause by the narrowband interference for multiple of the length of the codeword  $M$ , we cancel it by forcing that corrupted sequences to have the designed codebook sequence, which is the mapper code. The technique of the look-up table used here to cancel narrowband interference is actually based on the search of the minimum Hamming distance between the corrupted codeword and any element of the mapper code. The corresponding codeword will replace the corrupted one.

The power spectrum density of the substituted sequence will have nulls at the specific frequencies of the designed codebook. The technique of cancellation is general and can be implemented to any type of channels where the narrowband interference is highly present [12].

To guarantee a perfect detection and cancellation of the narrowband interference, it is advisable to have the nulls as wide as possible and this can be achieved by two methods. We can have different spectral nulls codebooks which generate the same nulls but with different length of codewords and this results of the differences in the values of the  $s$ , which refer to the number of symbols in each grouping.

Figure 9 shows how the wideness of a nulls vary with the variation of the parameter  $s$ .

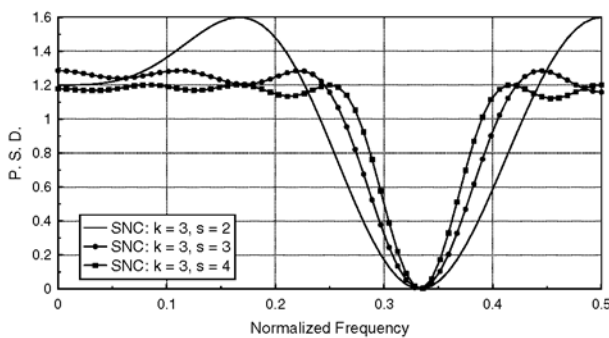

Figure 9: PSD of SN code for  $k = 3$  with different values of  $s$ .

The second method is to choose different codewords for the mappings with different digital sum variations. We have chosen three sets used for the mapping and plot their spectrum.  $S_1 = \{010101, 011100, 100011, 101010\}$ ,  $S_2 = \{000111, 010101, 101010, 111000\}$ ,  $S_3 = \{000111, 001110, 110001, 111000\}$ . Figure 10 shows the differences of the wideness of three sets of different codewords from the same original designed spectral nulls codebook.

6.4. *Error correction of the Narrow band Interference*

Canceling the narrow band interference is actually not error correcting the information data. As it is known that the look-up table is in fact a limited error-correction technique, so we need to correct our received data with other error correction algorithms like the Viterbi decoder. Before that we have to demultiplex the outputs from the OFDM demodulator.

As mentioned before, the DPM technique strengthen the performance of our Viterbi decoder. In the end, we get a new convolutional code as shown in Figure 11. Figure 11 shows the block diagram of the new system including the new OFDM modulator/demodulator. The performance of the system is shown in Figure 4.

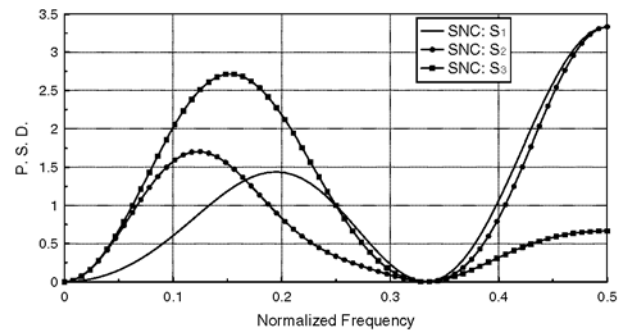

Figure 10: PSD of SN code for  $M = 6, k = 3$  with different subsets.

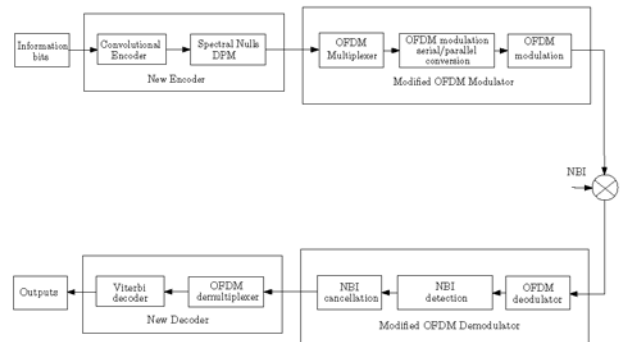

Figure 11: Block Diagram of the New Error Correction System

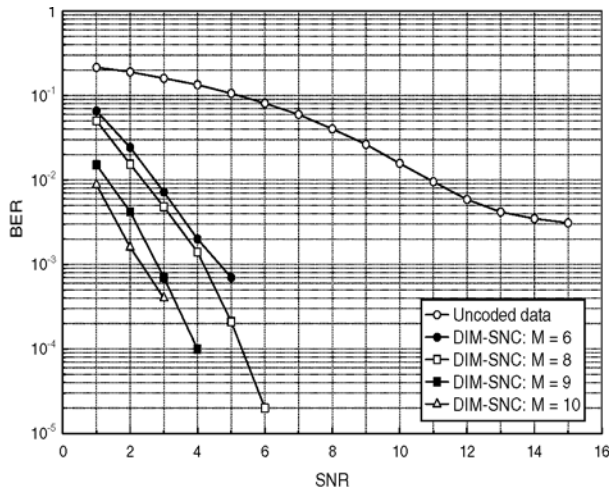

Figure 12: Hard decision decoding with QPSK/OFDM and AWGN + NBI.

It is clear from Figure 12 that our technique of DPM and the multiplexing of our data at the input of the OFDM transmitter helped us to track, cancel, and correct the data corrupted by the NBI.

## 7. CONCLUSION

New techniques of cancellation and correction of NBI were introduced. We have achieved three new things. The first is the generation of a spectral nulls codes, which previously used to be block codes, and which are now obtained from a convolutional code by using the DPM technique. The second is the improvement of the performance of the error correction capabilities of the Viterbi decoder by increasing the minimum distance. Thirdly a new OFDM transmitter and receiver were designed to be suitable to cancel the NBI.

The Viterbi decoder has a limitation against burst errors and NBI usually causes such errors, so we have to look further at how we can strengthen our decoder to be able to combat this type of errors better.

On the other hand we have to utilize the original spectrum as much as we can and this is done by using more codewords from the mapper code. Here we have to use convolutional codes with higher rates like  $2/3$  or  $3/4$  to map more codewords. We are also investigating another technique to better cover the spectrum and this by using the time-varying technique, which allows us to employ more codewords taking into consideration the changes that occur with the Viterbi Algorithm using a time varying trellis diagram.

## ACKNOWLEDGEMENT

This material is based upon work supported by Na-

tional Research Foundation under Grant Number 2053408, and furthermore partly completed during a visit at the University of Duisburg-Essen, Germany, under the supervision of Prof. A. J. H. Vinck.

## 8. REFERENCES

- [1] H. C. Ferreira, A. J. H. Vinck, T. G. Swart, and I. de Beer, "Permutation trellis codes," *IEEE Trans. Commun.*, vol. 53, no. 11, pp. 1782–1789, Nov. 2005.
- [2] E. Gorog, "Redundant alphabets with desirable frequency spectrum properties," *IBM J. Res. Develop.*, vol. 12, pp. 234–241, May 1968.
- [3] K. A. S. Immink, *Codes for mass data storage systems*, Chapter 12, Shannon Foundation Publishers, The Netherlands, 1999.
- [4] D. Slepian, "Permutation modulation," *Proc. IEEE*, vol. 53, no. 3, pp. 228–236, March 1965.
- [5] T. G. Swart, I. de Beer, H. C. Ferreira, and A. J. H. Vinck, "Simulation results for permutation trellis codes using M-ary FSK," *Proc. Int. Symp. on Power Line Commun. and its Applications*, Vancouver, Canada, April 6–8, 2005, pp. 317–319.
- [6] A. Viterbi and J. Omura, *Principles of digital communication and coding*. McGraw-Hill Kogakusha LTD, Tokyo Japan, 1979.
- [7] D. G. Daut, J. W. Modestino, and L. D. Wismer, "New short constraint length convolutional code constructions for selected rational rates," *IEEE Trans. Inform. Theory*, vol. IT-28, no. 5, pp. 794–800, September 1982.
- [8] J. G. Proakis and M. Salehi, *Communication systems engineering*. Prentice-Hall, Inc., Englewood Cliffs, New Jersey, 1994.
- [9] V. K. Ingle and J. G. Proakis, *Digital signal processing using Matlab V.4*. PWS Publishing Company, Boston, 1994.
- [10] D. Galda and H. Rohling, "Narrow band interference reduction in OFDM-based power line communication systems," *Proc. Int. Symp. on Power Line Commun. and its Applications*, Malmo, Sweden, April 4–6, 2001, pp. 345–351.
- [11] R. Nilsson, F. Sjoberg, and J. P. LeBlanc, "A rank-reduced LMMSE canceller for narrowband interference suppression in OFDM-based systems," *IEEE Trans. Commun.*, vol. 51, no. 12, pp. 2126–2140, December 2003.
- [12] K. Ouahada, H. C. Ferreira, A. J. H. Vinck, and W. A. Clarke, "Combined higher order spectral nulls codes and OFDM modulation for power line communications," *Proc. Int. Symp. on Power Line Commun. and its Applications*, Orlando, Florida, USA, March 26–29, 2006, pp. 122–127.