

On Mercury Vapor Lamps and Their Effect on the Smart-Grid PLC Channel

A. Emleh, A.S. de Beer, H.C. Ferreira

Department of Electrical and Electronic Engineering
Science

University of Johannesburg, P.O. Box 524,
Auckland Park, 2006, South Africa
{aemleh, asdebeer, hcferreira}@uj.ac.za

A.J. Han Vinck

Institute for Experimental Mathematics
Duisburg-Essen University
Ellernstr. 29, D-45326, Essen, Germany
vinck@iem.uni-due.de

Abstract— The mercury vapor lamp is the oldest high intensity discharge technology lamp that uses an electric arc, and comes in different shapes and designs. It creates a very bright light by using an arc through vaporized mercury in a high pressure tube. This lamp can cause unwanted interference to the smart-grid network or power line communications channel when connected to the channel's wiring system. In this paper we investigate the negative effects that the mercury vapor lamps with electric ballast have on the smart-grid PLC channel. This can have a strong and negative effect when using the smart-grid PLC network to control the automatic switching of lamps in public places. The narrowband and broadband channels are investigated where the interference level from mercury vapor lamps is significantly below the allowed maximum PLC signal levels on the band: (3 kHz – 150 kHz), and competes with Electromagnetic Compatibility (EMC) levels on the 150 kHz – 30 MHz band. The mercury vapor lamp uses an electric ballast to connect to the powerline system. This connection is explained in detail.

Index Terms— *Mercury Vapor Lamp; Electronic Ballast; Electromagnetic Ballast; Power line Communications; PLC; Interference; EN 50065-1; EMC; Smart-Grid.*

I. INTRODUCTION

Mercury vapor lamps are gas discharge lamps that are coated with phosphor on the outer bulb to provide thermal insulation and to protect from the ultraviolet radiation the light produces. They are more efficient than many other light sources with luminous efficacies of about 60 lumens/watt (a lumen is a measure of the amount of light that a given fixture produces) [1]. At first, they were constructed in a low pressure tube and used in many places and occasions. Nowadays, they are high pressure lamps with a fused quartz inner discharge tube. Mercury vapor lamps contain an arc that goes through argon gas and heats the tube. This operation causes the tube to

vaporize the mercury and creates a strong bright light between two electrodes that sit around the arc tube [1], [2].

Mercury vapor lamps are high energy lamps that are primarily used outdoor in sport arenas, landscaping, street lighting and signs, function stages, parking lots and industrial areas. They come in different shapes and designs (see Fig. 1), as well as different wattage outputs [1], and can be considered as long-life bulbs, in the vicinity of 24000 hours.

To operate a mercury vapor lamp, one can use an electric ballast. Mercury vapor lamps can use electronic or electromagnetic ballasts, or can be self-ballasted. The self-ballasted lamps use a filament that is connected in series with the arc tube and this is the only kind of mercury vapor lamp that can be connected directly to the 220V mains without using external ballast.

The ballast provides sufficient voltage to start the lamp and regulates the current to the lamp. During lamp starting, the ballast briefly supplies high voltage to establish an arc between the two lamp electrodes. Once the arc is established, the ballast reduces the voltage and regulates the electric current to produce a steady light output. Without a ballast to limit its current, a lamp connected directly to a high voltage power source would rapidly increase its current drawn. Within a second the lamp would overheat and burn out. [3], [4].

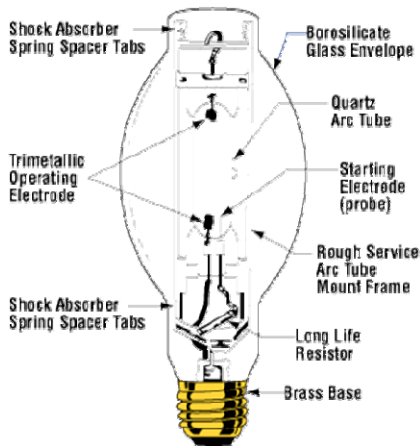

Fig. 1. The Inside Structure Of the Mercury Vapor Lamp [5].

Mercury vapor lamps with ballasts inject unwanted noise into the smart-grid power line communications network (PLC).

The so called CENELEC band (3 kHz – 150 kHz) gets affected by the conducted interference that the mercury vapor lamp causes when connected to the wiring system of the smart-grid network. This noise is below the allowed maximum PLC signal levels and therefore is considered below the “risk” levels.

In case of the broadband spectrum (150 kHz – 30 MHz), the noise level competes with, or exceeds the Electromagnetic Compatibility (EMC) levels.

This paper adheres to the CENELEC narrowband rules and serves the broadband standards and regulations too [6]. An explanation is given regarding the operational mode of the electric ballasts used with the mercury vapor lamps and to the measurements set-up as well.



Fig. 2. Electronic Ballast Used With Mercury Vapor Lamp.

II. MEASUREMENT SET-UP

The measurement set-up used is shown in Figs. 3 & 4.

A mercury vapor lamp is supplied with 220VAC through an isolation transformer and Line Impedance Stabilization Network (LISN). The isolation transformer is used as the LISN causes an earth-leakage current to flow, which causes the supply to trip. Floating the LISN rectifies this fault condition. The LISN as used in this set-up has two functions

Firstly, it filters noise from the AC supply. The measurement side (current probe and metal halide lamp in Fig. 3 & 4) is therefore clean from any noise on the power-line and an accurate assessment of the noise produced by the mercury vapor lamp can therefore be made. A clean 50Hz 220VAC is supplied to the mercury vapor lamp.

Secondly, it supplies a standardized noise load to the conducted interference created by mercury vapor lamp. At higher frequencies (typically > 1 MHz) the noise load impedance presented by the LISN (and seen by the mercury vapor lamp) is 50Ω.

Measurements and conclusions in this paper are made for two regions of the emission spectrum:

- **3 kHz – 150 kHz:** This is the frequency range of the so called *CENELEC* bands as defined by EN 50065-1 [7]. Measurements for these bands are made in the frequency domain to obtain harmonics from the resulted spectral density shape. A Rhode & Schwarz Spectrum Analyzer (ESR EMI Test Receiver) and ETS-Lindgren current probe (1 GHz) are used. It is assumed that the Common Mode (CM) currents are negligible in this band and that all interference is in Differential Mode (DM) – an assumption also used in EN 50065-1. Results are downloaded to a PC for processing. This is shown in Figs. 3 & 4, depending on the used ballast.

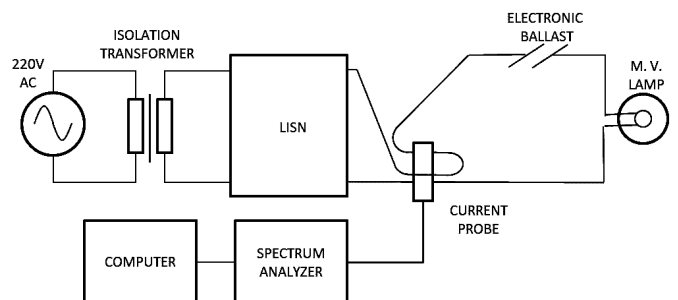

Fig. 3. Set-up for Measurements in the 3kHz – 30MHz Range (Electronic Ballast).

- **150 kHz – 30 MHz:** This is the frequency range for *Broadband* PLC. It spans the range traditionally used to measure conducted emissions as per CISPR-16 [8]. Measurements for this frequency range are also made using a Rhode & Schwarz Spectrum Analyzer and ETS-Lindgren current probe as shown in Figs. 3 & 4.

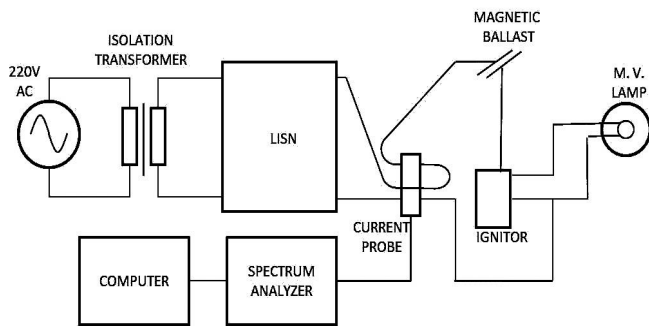

Fig. 4. Set-up for Measurements in the 3kHz – 30MHz Range (Electromagnetic Ballast).

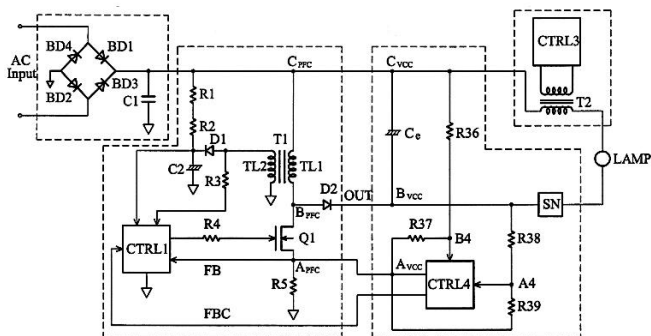

Fig. 5. Electronic ballast driver for mercury vapor lamp.

ELECTRICAL BALLAST DRIVER

Electronic ballasts are rarely used for mercury vapor lamps and are not readily found in the market since they can be a source of interference and give a shorter life to the mercury vapor lamp. Electromagnetic ballasts are widely used in most countries that have the mercury vapor lamp as a main outdoor lighting source. The main advantage for using the electronic ballast rather than electromagnetic ballast is the “intelligent switching” that the electronic ballast has. It is a function that allows the electronic ballast to turn off the mercury vapor lamp

when it comes to the end of its life, as the electronic ballast recognizes this condition and switches off the lamp. This enables easy identification of a defective lamp and prevents the lamp from being a “heavy” source of interference and disturbance to the power line communications channel [9].

Figure 5 shows the electric ballast used for mercury vapor lamps. The ballasts consist of different electronic components, such as, resistors, capacitors and inductors.

Ballasts are required to regulate and start the mercury vapor lamps, and to provide sufficient voltage and stabilize the current through the lamps.

Electric ballasts are supplied with 220V AC power which is internally converted to DC then back to variable frequency AC waveform.

III. HARMONICS - CENELEC BANDS

One of the most serious challenges to the power line communications channel is the interference. The mercury vapor lamps with electric ballasts do, unfortunately, inject undesired noise into the wiring system of the power line channel. This can negatively affect the transmission or receiving of bits or packets over the communications channel. When measurements are conducted, a current probe is used in order to determine the current harmonics that the mercury vapor lamps cause to the PLC channel. The current harmonics (magnitude) will, then, be represented in frequency domain waveforms. This is done by performing a Discrete Fourier Transform (DFT) and multiplying the current harmonics with the LISN impedance values that are used for measurements (Figs. 3 & 4) to get the voltage values. The LISN characteristics are specified in EN 50065-1 [7].

For discussion on the behavior of the narrowband signal on the low voltage network, we refer to Figs. 6 & 7. The conducted measurements in the so called CENELEC band (3 kHz – 150 kHz) show a small amount of harmonics (in voltage) which increases and, therefore, can be clearly seen during the warm-up period (typically 3 – 4 minutes) that the lamp needs to become stable after an operation of switching off and on again. In fact, the obtained harmonics pose no threat to the low voltage network as they can be classified as an allowed signal against CENELEC EN 50065-1 and Electromagnetic Compatibility (EMC) levels.

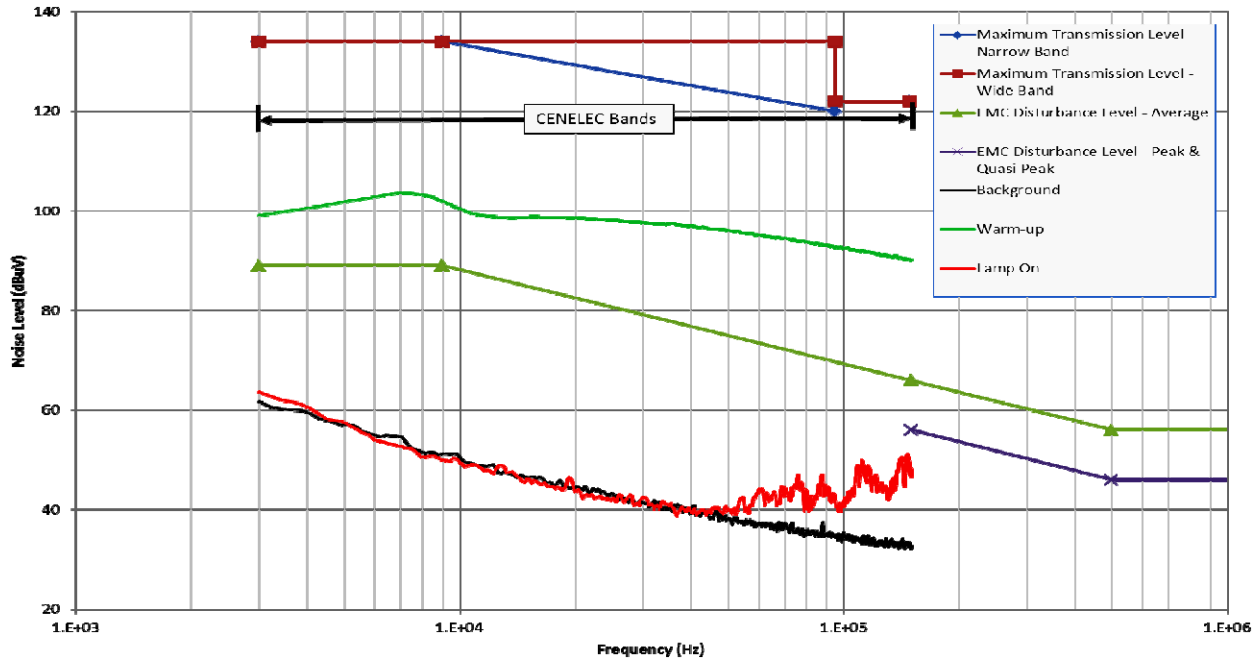

Fig. 6. Frequency domain waveforms and harmonics for 3kHz – 150kHz range (Electronic Ballast).

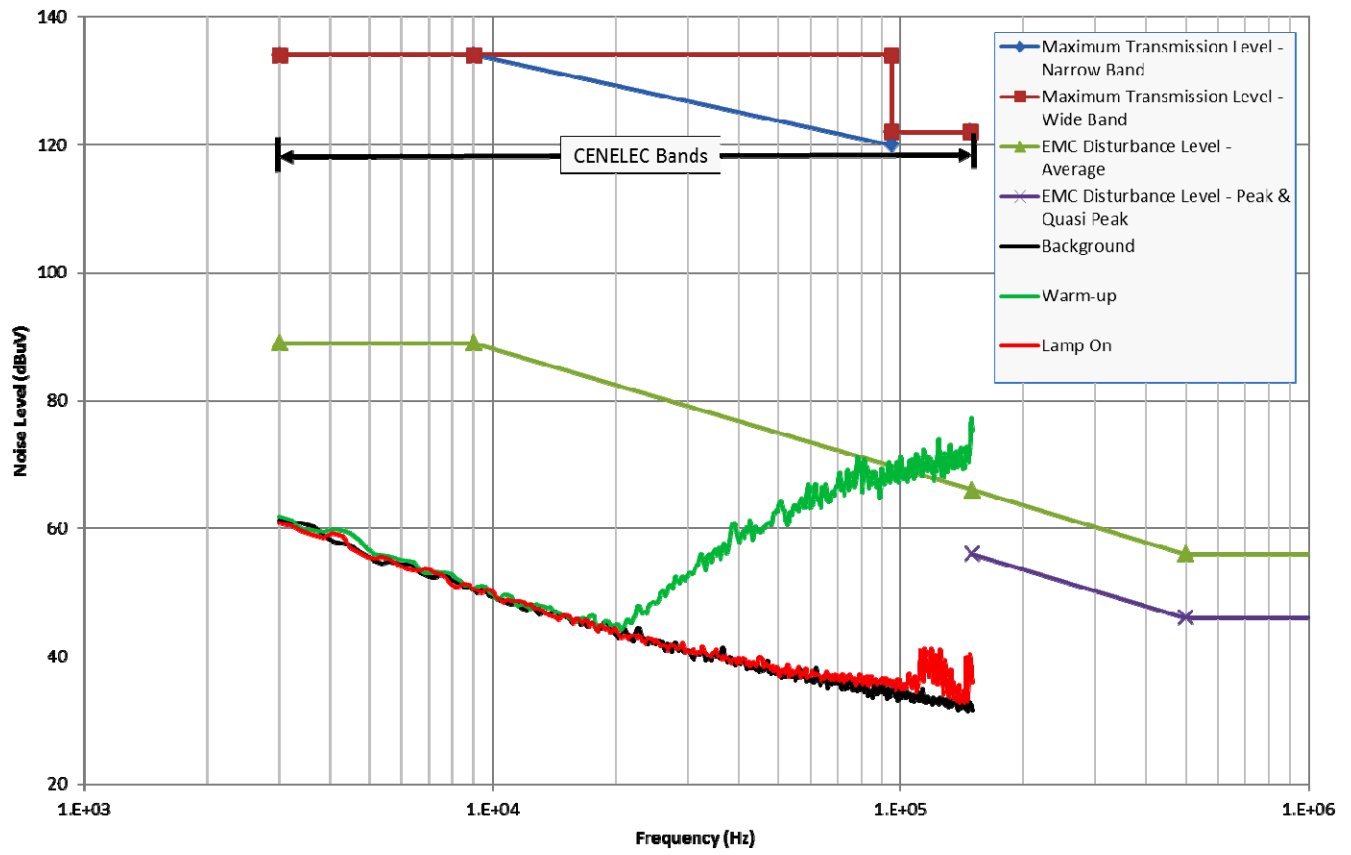

Fig. 7. Frequency domain waveforms and harmonics for 3kHz – 150kHz range (Electromagnetic Ballast).

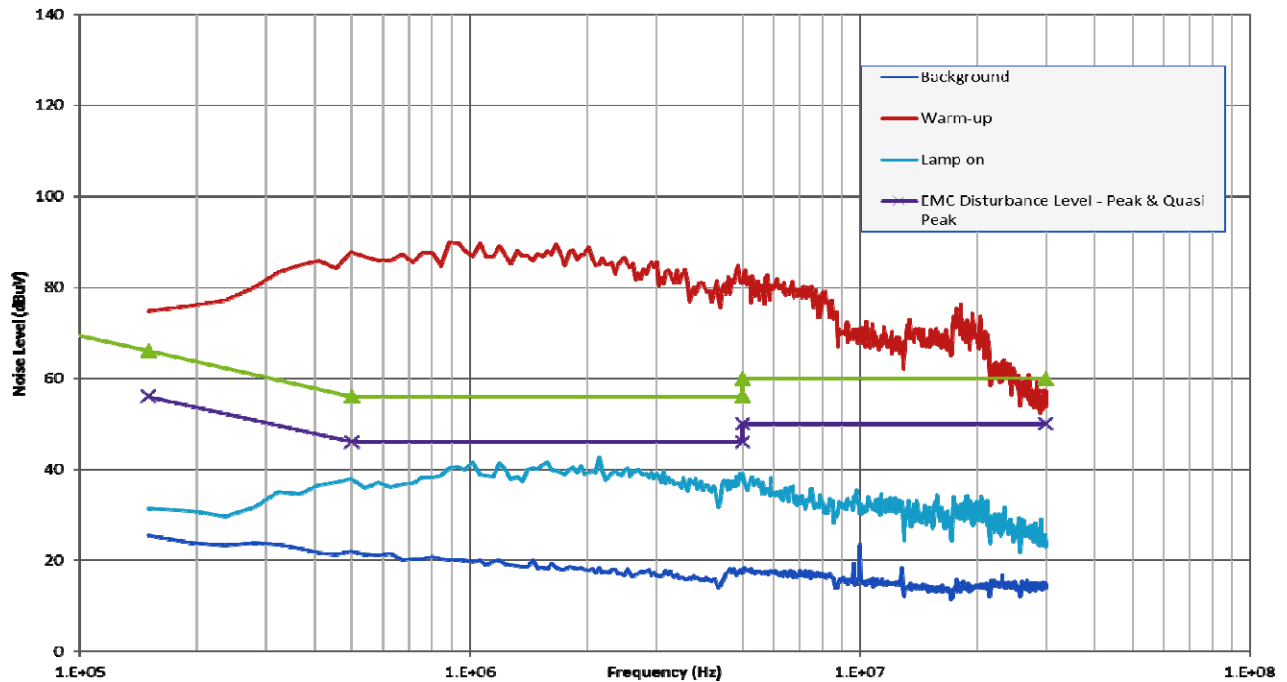

Fig. 8. Frequency domain waveforms and harmonics for 150kHz – 30MHz range (Electromagnetic Ballast).

The mercury vapor lamp produces an amount of interference when it reaches its full output. This happens when the warm-up period is passed. The signals from Figs. 6 & 7 that can be seen at around 100 kHz – 140 kHz are considered “friendly” harmonics as they are way below the maximum allowed signal level. However, in the worst scenario, the harmonics can hinder the transmission or receiving of bits and/or packets on the power line communications channel.

Measurements are conducted for three other mercury vapor lamps in order to test the behavior of the harmonics in the CENELEC band. One of the lamps has been in operation for three months and the other two have been operating for five years and seven years respectively. The results show that the oldest two lamps have a slight different behavior than the newer lamps. They produce more interference in the CENELEC band but this remains below the maximum allowed signal level.

IV. BROADBAND SPECTRUM

In this type of measurements, the broadband spectrum measurements are conducted to show the effect of the mercury vapor lamp on the PLC channel when it is connected to 220V where a similar procedure of measurements to those of the narrowband is followed. The broadband spectrum (150 kHz – 30 MHz) where the measurements are performed shows different levels of harmonics (in voltage) as the lamp produces an amount of interference when it gets stable after the warm up period of several minutes.

Figs. 8 & 9 illustrate the level of interference when the lamp is “on”, where it can be considered below the EMC disturbance level on peak & quasi peak measurements level. The level of

interference increases dramatically when the lamp is switched off and on again. For this type of measurements, this can be the worst scenario for the PLC channel, as the levels of interference compete with or exceed the maximum allowed Electromagnetic (EMC) levels.

This warm-up period can be of a serious risk to the power line channel as it produces a level of disturbance that can affect the communications over the wiring system on the PLC channel.

In the CENELEC bands from 3 kHz – 150 kHz there are dedicated maximum signal transmission levels. These do not exist in the 150 kHz – 30 MHz band and maximum signal transmission is assumed to be at the EMC limit levels.

In the broadband spectrum, the tests of the aging lamps are repeated as of the ones in the CENELEC band. The signal is almost stable in comparison with the obtained signal from the new lamps. The seven years old lamp shows a small change in the output signal but this causes no difference to the infected power line channel.

V. DISCUSSION AND ILLUSTRATION

Mercury vapor lamps have been used in lighting applications and are more energy efficient than other outdoor light sources. Besides the fact that they are not suited to render the human skin color well – as they are not used in retail stores, hospitals, schools and other commercial applications – they produce interference to the power line communications channel. They will only become a more favorable lighting solution (in PLC terms) if statutory signal limits are lifted in the 150 kHz – 30 MHz band.

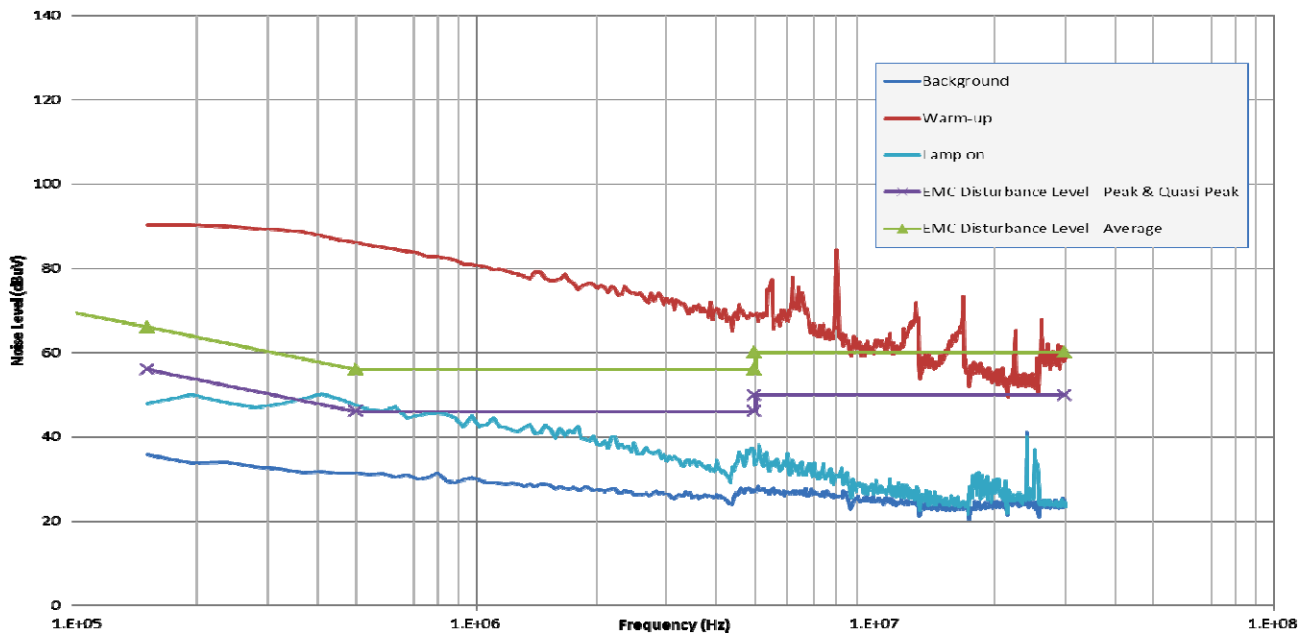

Fig. 9. Frequency domain waveforms and harmonics for 150kHz – 30MHz range (Electronic Ballast).

The smart-grid will need a more favorable light source when used to control the automatic switching of lamps in public places. The Light Emitting diodes (LEDs) can be one of the solutions for the future market as it causes less interference to the low voltage network.

VI. CONCLUSION

The mercury vapor lamp is one of the light sources that produce conducted noise when connected to the wiring system of the power line communications channel. This noise can be of a serious risk to the PLC channel if it exceeds the allowed maximum EMC noise levels as in the broadband spectrum range of 150 kHz – 30 MHz.

It has been shown that the level of noise in the CENELEC band (3 kHz – 150 kHz) is below the allowable PLC signal level and, therefore, it is “safe” to use the mercury vapor lamp in this frequency range.

ACKNOWLEDGMENT

This work is based on the research supported in part by the National Research Foundation of South Africa (Grant specific unique reference number (UID) 85884).

REFERENCES

- [1] J. W. ter Vrugt, J. K. P. Verwimp, “High Pressure Mercury Vapour Lamps”, IEE Proceedings on Physical Science, Measurement and Instrumentation, Management and Education, Vol. 127, Issue: 3, Publication Year: 1980, pp. 173 – 180.
- [2] M. Sugiura, “Review of metal-halide discharge-lamp development 1980-1992” IET Proceedings: Science, Measurements & Technology, Vol. 140, Issue 6, Publication Year: 1993, pp. 443 – 449.
- [3] K. Takahashi, M. Jinno, M. Aono, “The study of electronic ballast for fluorescent lamp with an electronic device given two functions,” IEEE Industry Applications Conference, Vol. 5, Publication Year: 2000, pp.3382-3387.
- [4] E. L. Corominas, M. Rico-Secades, J. A. Fernkndez-Rubiera, J. M. Alonso, A. J. Calleja, J. Ribas, J. Cardesin, “A Novel Low Cost Two-Stage Electronic Ballast for 250W High Pressure Mercury Vapor Lamps Based on Current-Mode-Controlled Buck-Boost Inverter”, Sixteenth Annual IEEE Applied Power Electronics Conference and Exposition, APEC 2001, Vol. 2, Publication Year: 2001, pp. 676 - 682.
- [5] Commercial Lighting, “Mercury Vapor Diagram”, Mercury Vapor Diagram5137 Clifton Street, Tampa, Florida, USA, www(dot)clcbulbs(dot)com, Last Accessed: 16 Nov 2014.
- [6] H. C. Ferreira, L. Lampe, J. Newbury and T. G. Swart, Power Line Communications: Theory and Applications for Narrowband and Broadband Communications over Power Lines, Chichester, England: John Wiley & Sons, 2010.
- [7] EN 50065-1: *Signaling on low-voltage electrical installations in the frequency range 3 kHz to 148,5 kHz - Part 1: General requirements, frequency bands and electromagnetic disturbances*. European Standard, CENELEC, Ref. No. EN 50065-1:2011 E, Brussels, April 2011.
- [8] CISPR 16: *Specification for radio disturbance and immunity measuring apparatus and methods*, International Electrotechnical Commission (IEC).
- [9] G. H. Wilson, E. L. Damant, J. M. Waldram, “The High-Pressure Mercury-Vapour Lamp In Public Lighting”, Journal of the Institution of Electrical Engineers, Vol. 79, Issue: 477, Publication Year: 1936, pp. 241 – 264.