

PDF hosted at the Radboud Repository of the Radboud University Nijmegen

The following full text is a publisher's version.

For additional information about this publication click this link.

<http://hdl.handle.net/2066/143103>

Please be advised that this information was generated on 2018-07-07 and may be subject to change.

Crystal and molecular structure of diiodo-N,N,N',N'-tetramethylthiuramdisulphidemercury(II)

P. T. BEURSKENS, J. A. CRAS, J. H. NOORDIK AND A. M. SPRULJT

*Department of Inorganic Chemistry,
University of Nijmegen, Nijmegen, The Netherlands*

(Received 16 February 1970)

Abstract

The crystal and molecular structure of diiodo-N,N,N',N'-tetramethylthiuramdisulphidemercury(II), $\text{HgI}_2(\text{S}_2\text{CN}(\text{CH}_3)_2)_2$, has been determined by a three-dimensional X-ray analysis. The compound crystallizes in the monoclinic space group $P2_1/c$ with the unit cell dimensions $a = 7.957 \pm 4$, $b = 22.639 \pm 7$, $c = 9.956 \pm 6$ Å and $\beta = 112.14 \pm 5^\circ$; $Z = 4$. Intensities were obtained with an automatic diffractometer. The structural parameters were refined by least-squares methods to a conventional R factor of 0.044 for 1294 non-zero observed reflexions. The mercury is in distorted tetrahedral coordination with two iodine and two sulphur atoms. The Hg—I distances are 2.654 ± 2 and 2.661 ± 2 Å; the Hg—S distances are 2.651 ± 7 and 2.882 ± 7 Å. The thiuramdisulphide ligand consists of two planar units S_2CNC_2 , nearly perpendicular to each other. Bond distances of the ligand are compared with distances in tetraalkylthiuram disulphide molecules and agree with infrared observations.

Introduction

In preceding papers, the preparations and properties of diiodo-N,N,N',N'-tetrabutylthiuramdisulphidemercury(II) (Brinkhoff *et al.*, 1969) and of the analogous ethyl derivative (Brinkhoff *et al.*, 1970) were reported. The proposed molecular structure was confirmed by an X-ray analysis of the analogous methyl derivative, $\text{HgI}_2(\text{Me}_4\text{tds})$.

Crystal and intensity data

Diiodo-N,N,N',N'-tetramethylthiuramdisulphidemercury(II), $\text{HgI}_2(\text{S}_2\text{CN}(\text{CH}_3)_2)_2$, FW 694.87, crystallizes in the space group $P2_1/c$ with the unit cell dimensions $a = 7.957 \pm 4$, $b = 22.639 \pm 7$, $c = 9.956 \pm 6$ Å, $\beta = 112.14 \pm 5^\circ$; $Z = 4$. The prismatic crystals are elongated along a . For practical reasons, the unconventional setting $B2_1/d$ was preferred (the transformation matrix to the conventional cell is $00\bar{1}/010/\frac{1}{2}0\frac{1}{2}$), with needle axis c , and the unit cell dimensions $a = 18.472 \pm 7$, $b = 22.639 \pm 7$, $c = 7.957 \pm 4$ Å and $\beta = 91.47 \pm 5^\circ$; $V = 3326 \pm 4$ Å³, $D_m = 2.76 \pm 3$ gcm⁻³ (pycnometer), $Z = 8$ and $D_x = 2.775 \pm 4$ gcm⁻³. Zirconium-filtered molybdenum radiation $\lambda(\text{Mo } K\alpha) = 0.7107$ Å was used. A crystal of approximately $0.06 \times 0.08 \times 0.38$ mm³ was mounted with the needle axis as rotation axis (ϕ axis). The systematic extinctions on Weissenberg and Precession photographs uniquely determined the space group. The cell dimensions were obtained by θ , ϕ and χ measurements on a Nonius diffractometer; the cell dimensions with their estimated standard deviations are the result of a least-squares treatment of fifteen reflexions in the range $10^\circ < \theta < 20^\circ$.

Intensity data were collected with an automatic Nonius diffractometer, using the moving counter-moving crystal method. Deviations from linearity of the scintillation counting equipment were less than 1%. The scan speed was 0.3°/min. Every 70 min, a reference reflexion was measured to detect fluctuations in the primary beam. Of the 3000 attainable symmetry-independent reflexions (up to $\sin \theta/\lambda = 0.595 \text{ \AA}^{-1}$) 1294 reflexions have been measured above background and used for the structure determination. The intensities were corrected for fluctuations in the primary beam and for Lorentz and polarization effects. No absorption correction was applied ($\mu r_{\max} = 0.5$; maximum effect upon the intensities: 13%).

Determination of the structure

The structure was solved by Patterson and Fourier methods; the positions of all atoms (except hydrogen) were located. After successful refinement with isotropic temperature factor parameters, the refinement was continued with anisotropic temperature parameters; the temperature factor was $\exp - (h^2\beta_{11} + k^2\beta_{22} + l^2\beta_{33} + 2kl\beta_{23} + 2lh\beta_{31} + 2hk\beta_{12})$. Because of computer program limitations, the following two procedures were used in turn:

- (1) full-matrix refinement of one scale factor and positional and vibrational parameters of all mercury, iodine and sulphur atoms.
- (2) full-matrix refinement of the same scale factor and positional and vibrational parameters of all carbon and nitrogen atoms.

After three cycles (1 and 2), all shifts were negligible. The function minimized was $w(|F_o| - |F_c|)^2$, with the weight w for each reflexion as obtained from counting statistics. The atomic scattering factors used were those of the neutral atoms corrected for anomalous scattering ($\Delta f'$), with data from the International Tables (1962). The final conventional R factor is 0.044.

The final difference Fourier map showed some maxima of 0.7 e\AA^{-3} around the mercury position, and on the mercury position a minimum of about -0.5 e\AA^{-3} . At distances varying from 0.7 to 1.5 Å to the methylcarbon positions, a number of maxima of height $0.3\text{--}0.5 \text{ e\AA}^{-3}$ were found but none of these could be interpreted clearly as hydrogen.

Calculations were performed on an IBM 360/50 computer, using programs written by Busing *et al.* (1962), Pippy & Ahmed (1967), Beurskens *et al.* (1969) and Beurskens (1968).

Description of the molecule

The atomic parameters are given in table 1, and the structure is illustrated in Fig. 1. Bond distances and angles are given in Fig. 2; the shortest S—S van der Waals contact is $3.78(1) \text{ \AA}$.

The coordination of mercury is shown in Fig. 3. The mercury atom is equidistant to the two iodine and the S(1) atoms (2.66 \AA), and is only $0.305 \pm 1 \text{ \AA}$ out of the plane of these three atoms. The Hg—S(4) bond (2.88 \AA) is significantly longer and nearly perpendicular (84°) to this plane. A similar geometry was found in the compound $[\text{S}(\text{CH}_3)_3]_2\text{HgI}_4$ (Fenn, 1966), with three Hg—I bonds of 2.70 \AA (average) and one Hg—I bond of 2.80 \AA . The Hg—S(4) distances in other tetrahedrally coordinated mercury compounds are, for example, 2.33 \AA in HgS (*metacinnabar*) (Aurivillius, 1950) and 2.61 \AA in $\text{HgCl}_2\text{-1,3,5-trithian}$ (Costello *et al.*, 1966). The S—Hg—S and I—Hg—I angles agree within 3° with the relationship between coordination angles given by Cheung & Sim (1965).

The thiuramdisulphide ligand contains two planar groups S_2CNC_2 . The equation of the least squares plane through S(1)S(2)C(1)N(1)C(3)C(4) is

$$0.0308X + 0.5997Y + 0.7997Z - 0.3465 = 0$$

with the deviations from the plane

S(1): $-0.003(7)$	N(1): $-0.01(2)$
S(2): $0.005(7)$	C(3): $-0.04(2)$
C(1): $-0.03(2)$	C(4): $0.08(2)$

Table 1. Atomic parameters for $HgI_2(Me_4tds)$ and standard deviations

	<i>x</i>	<i>y</i>	<i>z</i>	β_{11}	β_{22}	β_{33}	β_{12}	β_{13}	β_{23}
Hg	0.0703(1)	0.1690(1)	0.1030(2)	0.0035(1)	0.0020(1)	0.0198(3)	-0.0004(1)	0.0022(1)	-0.0009(1)
I(1)	-0.0418(1)	0.1271(1)	0.2697(3)	0.0032(1)	0.0033(1)	0.0247(6)	-0.0001(1)	0.0014(2)	0.0025(1)
I(2)	0.1487(1)	0.2660(1)	0.0627(3)	0.0051(1)	0.0019(1)	0.0272(6)	-0.0008(1)	0.0009(2)	-0.0008(1)
S(1)	0.0703(3)	0.1059(3)	-0.1776(9)	0.0026(2)	0.0031(2)	0.0170(18)	-0.0003(2)	0.0001(6)	-0.0021(5)
S(2)	0.2306(3)	0.0795(3)	-0.1370(9)	0.0029(3)	0.0033(2)	0.0216(20)	0.0007(2)	0.0007(6)	0.0017(5)
S(3)	0.1817(4)	0.0106(3)	-0.0241(10)	0.0056(3)	0.0019(2)	0.0210(21)	0.0007(2)	0.0012(7)	-0.0004(5)
S(4)	0.1896(3)	0.1038(3)	0.2520(9)	0.0035(3)	0.0019(2)	0.0200(19)	0.0001(2)	-0.0034(6)	-0.0002(5)
C(1)	0.1579(10)	0.1242(9)	-0.2202(28)	0.0019(8)	0.0022(6)	0.0061(56)	-0.0001(6)	-0.0017(18)	-0.0028(16)
N(1)	0.1756(9)	0.1684(8)	-0.3188(23)	0.0036(8)	0.0015(4)	0.0126(49)	-0.0018(6)	0.0016(16)	-0.0012(14)
C(2)	0.1662(11)	0.0328(10)	0.1949(28)	0.0025(9)	0.0026(7)	0.0037(60)	0.0014(7)	-0.0002(19)	-0.0018(16)
N(2)	0.1314(9)	-0.0046(10)	0.2809(28)	0.0016(7)	0.0034(7)	0.0148(57)	0.0004(6)	0.0012(17)	0.0048(18)
C(3)	0.2536(12)	0.1806(10)	-0.3473(28)	0.0036(10)	0.0026(8)	0.0139(63)	-0.0016(7)	0.0033(21)	0.0012(17)
C(4)	0.1173(12)	0.2051(11)	-0.4065(33)	0.0046(11)	0.0022(7)	0.0302(79)	0.0030(7)	-0.0061(25)	-0.0017(18)
C(5)	0.1117(13)	0.0086(8)	0.4544(33)	0.0027(9)	0.0039(8)	0.0106(67)	0.0014(7)	-0.0001(21)	0.0025(20)
C(6)	0.1142(12)	-0.0643(9)	0.2156(36)	0.0037(10)	0.0006(5)	0.0472(97)	-0.0011(6)	0.0012(25)	-0.0028(19)

The key to the atomic numbering is given in Figure 2. The general positions for space group $B2_1/d$ are: $(0,0,0; \frac{1}{2},0,\frac{1}{2}) \pm (x,y,z; \frac{1}{2} + x, \frac{1}{2} - y, \frac{1}{2} + z)$. The positions for the $P2_1/c$ setting are given by the transformation matrix $10\bar{1}/010/200$.

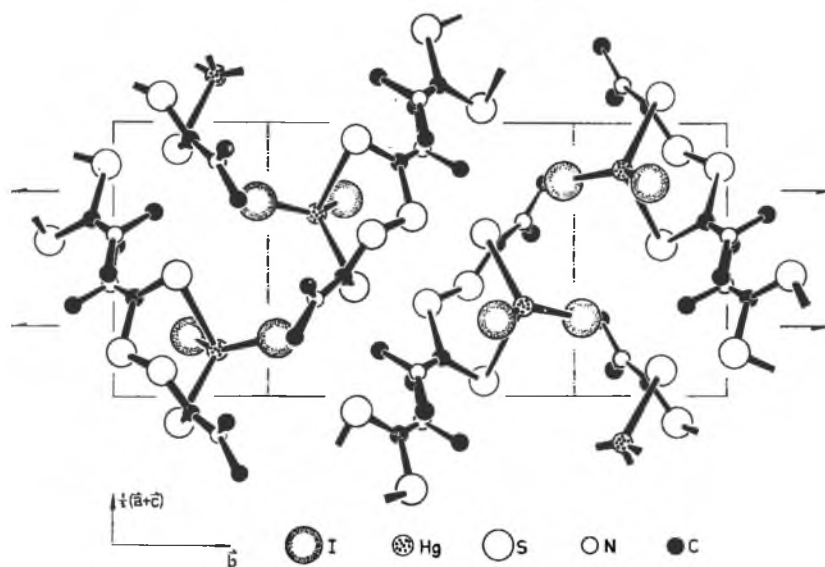
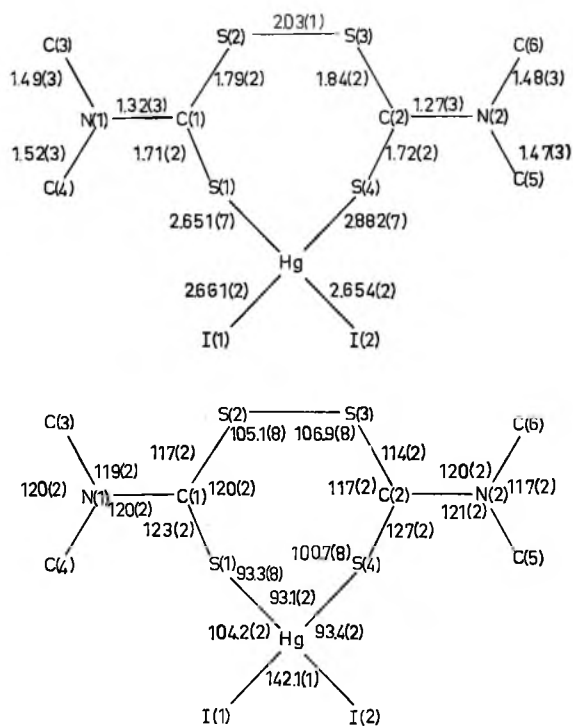
Fig. 1. Projection of $\text{HgI}_2(\text{Me}_4\text{tds})$ on (101).Fig. 2. Bond distances and angles in $\text{HgI}_2(\text{Me}_4\text{tds})$ and standard deviations. The bond angles $\text{I}_1 - \text{Hg} - \text{S}_4 (102.1 \pm 2^\circ)$ and $\text{I}_1 - \text{Hg} - \text{S}_1 (109.4 \pm 2^\circ)$ are not given in the figure.

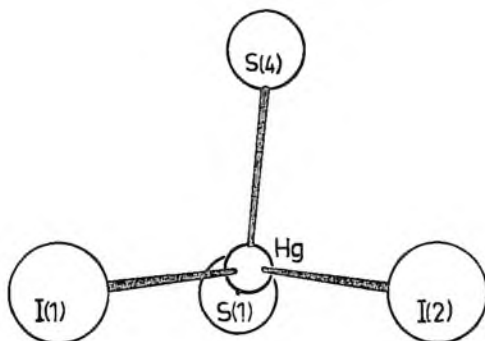

Fig. 3. Coordination of the Hg atom. Projection parallel to the plane through I(1), I(2) and S(1).

The plane through S(3)S(4)C(2)N(2)C(5)C(6) is given by

$$0.8852X - 0.3523Y + 0.3038Z - 2.8330 = 0$$

with the deviations from the plane

$$\begin{array}{ll} \text{S(3): } 0.001(7) & \text{N(2): } 0.02(2) \\ \text{S(4): } 0.002(7) & \text{C(5): } -0.03(2) \\ \text{C(2): } -0.06(2) & \text{C(6): } 0.06(2) \end{array}$$

The dihedral angle between these planes is 86.6° . The atom S(2) is situated in both planes, and the dihedral C—S—S—C angle is 89.2° .

In Table 2, the geometry of the thiuramdisulphide ligand in $\text{HgI}_2(\text{Me}_4\text{tds})$, is compared with the geometry of tetramethylthiuramdisulphide (Me_4tds) (Marøy, 1965) and tetraethylthiuramdisulphide (Et_4tds) (Karle, Estlin and Britts, 1967). The observed C—N distances are not conclusive with respect to the increase of the C—N bond order as indicated by infrared and nmr measurements. The difference in the C—S distances agree with the infrared spectra (Brinkhoff *et al.*, 1970).

Table 2. Comparison of the geometry in thiuramdisulphide

	$\text{HgI}_2(\text{Me}_4\text{tds})$	Me_4tds	Et_4tds
C(1)—N(1), C(2)—N(2)	1.27, 1.32 Å	1.31 Å	1.33, 1.36 Å
C(1)—S(1), C(2)—S(4)*	1.71, 1.72 Å	1.61 Å	1.66, 1.63 Å
S(2)—S(3)	2.03 Å	2.00 Å	2.00 Å
Dihedral C(1)—S(2)—S(3)—C(2) angle	89.2°	88°	96.4°

* C—S bond in Me_4tds and Et_4tds .

The authors are grateful to Professor J. J. Steggerda for his continuous interest, and to Mr W. P. J. H. Bosman and Mr J. M. M. Smits for valuable assistance.

References

- Aurivillius, K. L. (1950) *Acta Chem. Scand.* **4**, 1413.
 Beurskens, P. T. (1968) *A Fourier Computer Program* (unpublished).
 Beurskens, P. T., Noordik, J. H. & Bosman, W. P. J. H. (1969) *Fortran Computer Programs for Cell Dimensions, Setting Angles and Data Reduction for the Nonius Automatic Diffractometer* (unpublished).
 Brinkhoff, H. C., Cras, J. A., Steggerda, J. J. & Willemsse, J. (1969) *Rec. Trav. Chim.* **88**, 633.
 Brinkhoff, H. C., Grotens, A. M. & Steggerda, J. J. (1970) *Rec. Trav. Chim.* **89**, 11.

- Busing, W. R., Martin, K. O. & Levy, H. A. (1962) *Fortran Least Squares Program (ORFLS)*.
Cheung, K. K. & Sim, G. A. (1965) *J. Chem. Soc.* 5988.
Costello, W. R., McPhail, A. P. & Sim, G. A. (1966) *J. Chem. Soc. (A)*, 1190.
Fenn, R. H. (1966) *Acta Cryst.* **20**, 24.
Karle, I. L., Estlin, J. A. & Britts, K. (1967) *Acta Cryst.* **22**, 273.
Marøy, K. (1965) *Acta Chim. Scand.* **19**, 1509.
Pippy, M. E. & Ahmed, F. R. (1967) *Scan of Interatomic Distances and Angles (NRC-12), Mean Plane (NRC-22)*.

National Lending Library Supplementary Publication No. 60006 contains 4 pages of structure factor tables on 1 microfiche.