

RESEARCH ARTICLE

Spiders on a Hot Volcanic Roof: Colonisation Pathways and Phylogeography of the Canary Islands Endemic Trap-Door Spider *Titanidiops canariensis* (Araneae, Idiopidae)

Vera Opatova*, Miquel A. Arnedo

Institut de Recerca de la Biodiversitat & Departament de Biologia Animal, Universitat de Barcelona, Barcelona, Spain

*Vera.Opatova@gmail.com



CrossMark
click for updates

OPEN ACCESS

Citation: Opatova V, Arnedo MA (2014) Spiders on a Hot Volcanic Roof: Colonisation Pathways and Phylogeography of the Canary Islands Endemic Trap-Door Spider *Titanidiops canariensis* (Araneae, Idiopidae). PLoS ONE 9(12): e115078. doi:10.1371/journal.pone.0115078

Editor: Nadir Alvarez, University of Lausanne, Switzerland

Received: April 12, 2014

Accepted: November 3, 2014

Published: December 10, 2014

Copyright: © 2014 Opatova, Arnedo. This is an open-access article distributed under the terms of the [Creative Commons Attribution License](https://creativecommons.org/licenses/by/4.0/), which permits unrestricted use, distribution, and reproduction in any medium, provided the original author and source are credited.

Data Availability: The authors confirm that all data underlying the findings are fully available without restriction. Data have been deposited to GenBank (KM110228-KM110710).

Funding: This project was funded by Spanish Ministry of Science and Innovation (MICINN) grants CGL 2009-07639 and CGL2012-36863 (both to MA) and additional financial support was provided by project 2009SGR1462 from the Generalitat de Catalunya. VO was supported by a graduate grant (AP 2008-01841). MA was further supported by an ICREA Academia award for excellence in research from the Generalitat de Catalunya. The funders had no role in study design, data collection and analysis, decision to publish, or preparation of the manuscript.

Competing Interests: The authors have declared that no competing interests exist.

Abstract

Studies conducted on volcanic islands have greatly contributed to our current understanding of how organisms diversify. The Canary Islands archipelago, located northwest of the coast of northern Africa, harbours a large number of endemic taxa. Because of their low vagility, mygalomorph spiders are usually absent from oceanic islands. The spider *Titanidiops canariensis*, which inhabits the easternmost islands of the archipelago, constitutes an exception to this rule. Here, we use a multi-locus approach that combines three mitochondrial and four nuclear genes to investigate the origins and phylogeography of this remarkable trap-door spider. We provide a timeframe for the colonisation of the Canary Islands using two alternative approaches: concatenation and species tree inference in a Bayesian relaxed clock framework. Additionally, we investigate the existence of cryptic species on the islands by means of a Bayesian multi-locus species delimitation method. Our results indicate that *T. canariensis* colonised the Canary Islands once, most likely during the Miocene, although discrepancies between the timeframes from different approaches make the exact timing uncertain. A complex evolutionary history for the species in the archipelago is revealed, which involves two independent colonisations of Fuerteventura from the ancestral range of *T. canariensis* in northern Lanzarote and a possible back colonisation of southern Lanzarote. The data further corroborate a previously proposed volcanic refugium, highlighting the impact of the dynamic volcanic history of the island on the phylogeographic patterns of the endemic taxa. *T. canariensis* includes at least two different species, one inhabiting the Jandia peninsula and central Fuerteventura and one spanning

from central Fuerteventura to Lanzarote. Our data suggest that the extant northern African *Titanidiops* lineages may have expanded to the region after the islands were colonised and, hence, are not the source of colonisation. In addition, *T. maroccanus* may harbour several cryptic species.

Introduction

Oceanic islands due to their volcanic origin are ideal systems for evolutionary studies [1]. Episodes of volcanic activity have left their fingerprints on the genetic diversity and distribution of endemic terrestrial organisms. Recurrent range shifts, geographic isolation and population bottlenecks driven by lava flows have shaped the complex phylogeographic patterns and have led speciation in local organisms [2, 3, 4, 5, 6, 7, 8, 9].

The Canary Islands archipelago lies in the Atlantic Ocean, approximately 110 km from the north-western coast of Africa, comprising seven main islands and several smaller islets (Fig. 1). The region harbours a significant number of endemic organisms; 50% of the known invertebrates and 27% of the vascular plants inhabiting the archipelago are Canarian endemics. This extraordinary biological richness has been traditionally interpreted in many organisms as a relict of the Tertiary Mediterranean diversity, but the advent of molecular phylogenetics revealed a large amount of in situ diversification [10]. Some groups, however, have colonised the archipelago repeatedly [11, 12, 13, 14].

The archipelago was built by several cycles of volcanic activity tracing back to the Miocene and persisting until today [15, 16, 17]. The islands on the eastern side were the first to emerge, and the remaining islands appeared subsequently, following an east to west pattern [15]. Fuerteventura, Lanzarote and the surrounding islets, hereafter referred to as the Eastern Canary Islands, are the emergent parts of a volcanic ridge that runs parallel to the African coast. The islands are separated by shallow waters and have been repeatedly connected during marine transgressions [18]. The sub-aerial stage of Fuerteventura began approximately 22 million years ago (Ma), and the volcanism progressed in a SSW-NNE direction. After several rounds of volcanic activity followed by periods of erosional quiescence, post-erosional volcanic activity began in Lanzarote approximately 1.6 Ma, and eruptions have been documented even in historic times [18, 19].

The infraorder Mygalomorphae is one of the three main lineages recognised within spiders [20], representing approximately 6.3% of extant spider diversity [21]. Mygalomorphs are generally robust spiders that lack the ability to spin complicated web structures and present other characters regarded as plesiomorphic among the spiders, such as four book lungs and chelicerae with unsynchronised movement of the longitudinal fangs [22]. Mygalomorphs show high levels of local endemism, which is generally attributed to their low dispersal

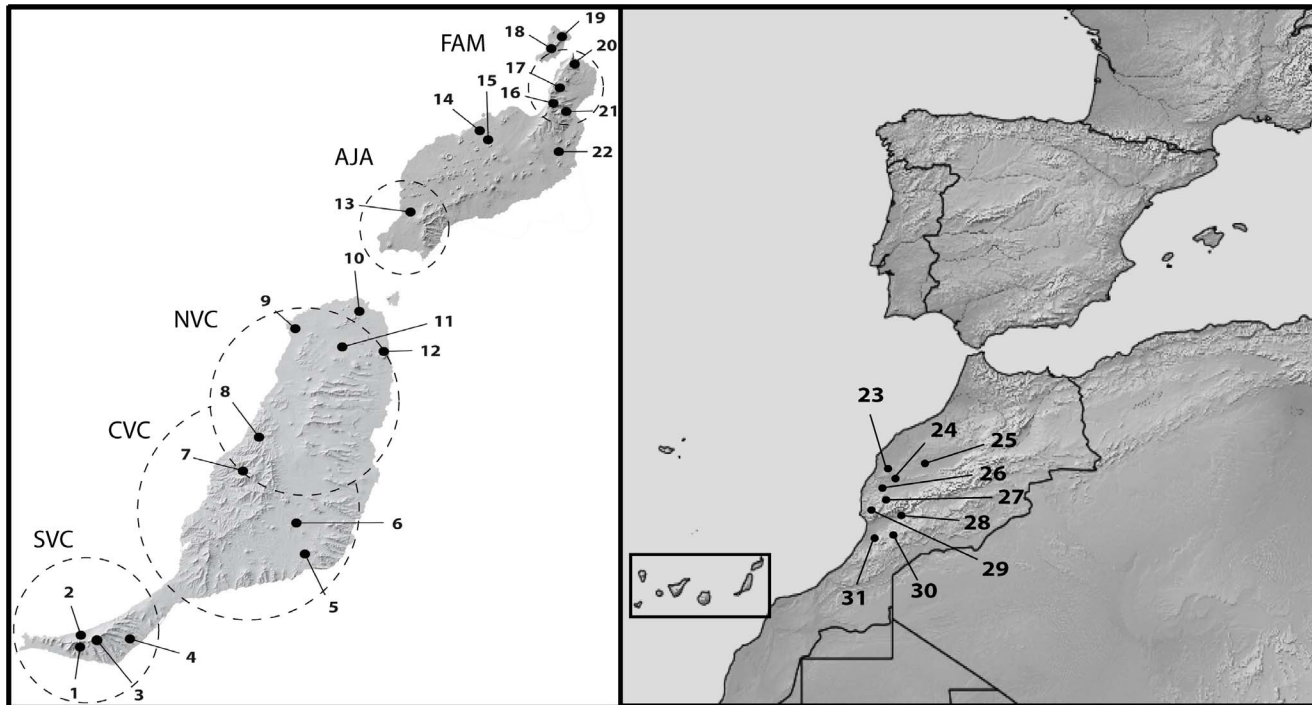

Fig. 1. *Titanidiops* sampling locations, 1: Barranco del Ciervo, 2: Cofete, 3: Pico de Fraile, 4: Barranco Mal Nombre, 5: Tequital, 6: Caldera la Laguna, 7: Betancuria, 8: Valle de Aguas Verdes, 9: Faro Tscón, 10: Corralejo, 11: Villaverde, 12: Caldería de la Roja, 13: Salinas de Janubio, 14: Tinajo, 15: Tinache, 16: Valle de Malpaso, 17: Valle de Guinate, 18: Montaña de Mojón, 19: El Vallichuelo, 20: Mirador del Río, 21: Barranco Hondo del Valle, 22: Teja, 23: Smi-Mou, 24: Kemis-oulat-el-Hadj, 25: Ouzoud Falls rd., 26: Jbele Amsittene, 27: Tamanat - Aid-Beoude rd., 28: Iguer rd., 29: Imoza rd. nr. Tourarin, 30: Ait-Aisa, 31: Aid-Baha. For detailed information, see [S1 Table](#). The map was created using SimpleMappr <http://www.simplemapp.net/>. Circled areas correspond to the location of the Volcanic Complexes on Fuerteventura and Lanzarote [75]. SVC: Southern Volcanic Complex, CVC: Central Volcanic Complex, NVC: Northern Volcanic Complex, AJA: Los Ajaches, FAM: Famara.

doi:10.1371/journal.pone.0115078.g001

ability [23, 24]. They show phenological and behavioural sex dimorphism; females tend to be long-lived and sedentary, while short-lived adult males actively search for mates after moulting and, thus, mediate gene flow among the populations.

The taxonomy of the group is challenging, as most of the closely related taxa are morphologically homogenous and the majority of diagnostic characters are found in the reproductive organs of adult males, usually present in the field for a short period of time. Because of their uniform morphology and poor dispersal ability, which causes deep genetic structuring even among geographically close populations, mygalomorphs have become a model system to test species boundaries [24, 25, 26, 27].

Mygalomorphs are notoriously absent from oceanic islands, and the few exceptions involve species either in the Caribbean [21], belonging to groups for which airborne dispersal has been reported [28, 29, 30], or in the Australian region, where the existence of land bridges during sea level changes cannot be ruled out [31]. In this regard, the presence of the trap-door spider *Titanidiops canariensis* Wunderlich, 1992 (Fig. 2) on the Canary Islands has great



Fig. 2. Picture of *Titanidiops canariensis* from loc. 7: Betancuria, photo credit VO.

doi:10.1371/journal.pone.0115078.g002

biogeographic relevance, as the archipelago was never connected to the continent, and the family Idiopidae, to which it belongs, has had no reported cases of aerial dispersal.

Idiopids are widespread across Australia, New Zealand, South-East Asia, Sub-Saharan Africa, Madagascar and South America but also include a few disjoint species in North Africa and the Middle East [21]. This wide distribution is often attributed to the Gondwanan origin of the family [20, 32]. The family is well defined on a morphological basis [22], and its monophyly has been subsequently supported by molecular studies [20, 32, 33]. The genus *Titanidiops* currently comprises only three species: *T. canariensis*, endemic to the Canary Islands; *T. maroccanus* Simon, 1909 from Morocco; and the type species *T. compactus* Gerstäcker, 1873, which occurs in East Africa. *T. canariensis* inhabits the Eastern Canary Islands, where it can be found in most habitats with the exception of sand dunes and barren lava badlands (i.e., lava flows of recent origin). The spiders are mid-size and ground dwelling, and they construct underground, silk-lined burrows that open to the surface with a trap-door [34, 35]. There is almost no information known regarding its ecology, life cycle or phylogenetic affinities.

This study aims to uncover the phylogenetic origins of *T. canariensis*, one of the few examples of trap-door spiders endemic to an oceanic archipelago, and to infer the temporal framework for the colonisation of the islands using a multi-locus approach. Because of the low vagility of trap-door spiders and the dynamic volcanic history of the Eastern Canaries, we hypothesise deep and complex phylogeographic patterns, which may have led to the formation of cryptic species.

Materials and Methods

Taxonomic sampling

Most of the *Titanidiops* samples used in the present study were collected by the first author between 2009 and 2010. Additional specimens of *Titanidiops canariensis* and one specimen of the genus *Segregara* were kindly donated by colleagues. Three other representatives of the family Idiopidae were included in the analyses: *Idiops syriacus* from Israel, *Idiops* sp. from South Africa [20] and *Segregara* sp. from South Africa. The last species was used as an outgroup to root the trees. Detailed locality data are included in [S1 Table](#). Sampling in the Eastern Canary Islands was conducted under permit num. 4012 granted by the Cabildo de Fuerteventura. Sampling in Morocco was conducted outside designated protected areas. The specimens of *Idiops syriacus* were collected under the collection permit 2011/38207 granted by the Israeli government to Y. Lubin and extended to the 26th European Congress of Arachnology participants.

DNA extraction, PCR amplification, cloning and sequencing

Whole genomic DNA was extracted from the samples using the SpeedTools Tissue Extraction Kit (Biotools) following the manufacturer's guidelines. Partial fragments of four mitochondrial and four nuclear genes were sequenced in present study: 5' half of the Cytochrome oxidase I (*cox1*) (the animal barcode), the 3' half of the 16S rDNA (*16S*), the *tRNA-Leu* (*L1*) and the 5' half of the NADH dehydrogenase subunit I (*nad1*), a fragment of the 28S rDNA (*28S*), Elongation factor-1 gamma (*EF1 γ*), Histone H3 (*H3*) and one anonymous locus amplified with primers designed for the Heat Shock Protein Hsp 70 [36] (*AL1-Hsp70*), respectively.

The PCR amplifications were carried out with the following primer combinations. *Cox1* with the primer pair C1-J-1490/C1-N-2198 [37], the fragment comprising the 16S, *L1* and *nad1* with the primer pair LR-N-13398 [38]/N1-J-12261 [39] or, alternatively, only the 3' half of the 16S with LR-N-13398 combined with LR-J-12864 [4]. All mitochondrial fragments were successfully amplified at annealing temperature range of 43–46°C. For the nuclear genes, 28S was amplified with 28S-O/28S-B or 28S-O/28S-C [40, 41] at 62–64°C annealing temperature. The *EF1 γ* fragment was amplified with primers ER1gF78/EF1 γ R1258 [32] and primer pair designed in the present study EF-gIDIf 5'-GGCAACAACCAGCTCGTGGA -3'/EF-gIDIr 5'-GTGCTGTTATTA-TCTTCGCC -3', at 52°C annealing temperature. Histone *H3* was amplified with the primer combination H3a F/H3a R [42]. The *AL1-Hsp70* anonymous locus was amplified with the Heat Shock Protein primers MT70-MF3/MT70-R4 [36] and complemented with a newly designed primer pair for *T. canariensis* Hsp70-TitMF3 5'-AGCGACATGATGCCGAGAGT -3'/Hsp70-TitR4 5'-GGAGGATGCAGTGGACATGG -3' yielding amplifications at 52–54°C. Some individuals showed *AL1-Hsp70* amplicons of different length and were further purified and cloned using the pGem-T kit (Promega).

All the reactions were carried out mixing 1.25 U *Taq* polymerase (Promega), 2.5 mM MgCl₂ (Promega), 0.2 mM of each dNTP, 0.2 μM of each primer and 1.5 μl of DNA and the 5 μl of *Taq* buffer and adding ultrapure, distilled water up to a total reaction volume of 25 μl. PCR products were purified using ExoSAP-IT (USB Corporation) and sequenced in both directions using BigDye Terminator v3.1 Cycle Sequencing Kit (Applied Biosystems) on ABI 3700 automated sequencer at *Centres Científics i Tecnològics* of the University of Barcelona (CCiTUB, www.ccitub.edu) Spain. The chromatograms were assembled and edited in Geneious v. 5.3.6. [43].

Sequence alignment, allele phasing and recombination testing

All gene fragments with exception of *nad1* and *H3* presented length polymorphism due to indel mutations. Sequence alignments of *28S*, *16S*, *L1* and *AL1-Hsp70* were obtained with the online version of MAFFT v. 6 [44], (available at <http://mafft.cbrc.jp/alignment/server/>) using the Q-INS-i approach with default settings (gap opening penalty GOP=1.53 and offset value set to 0.0). Online version of the alignment program TranslatorX [45] (available at <http://www.translatorx.co.uk/>), which uses amino acid back translation to guide the nucleotide alignment, was used to build the alignments of protein coding genes *cox1* and *EF1γ*. The alignments of *nad1* and *H3* were trivial since no length variation was observed in this gene fragments.

The allelic phases of the nuclear gene fragments were determined using the PHASE algorithm [46, 47] as implemented in DnaSP 5.10.1 [48]. Recombination was tested by means of the difference of sum of squares method (DSS) as implemented in TOPALi v 2.5 [49, 50]. The size of sliding window was set to 500 bp in all fragments except for *H3*, where a 300 bp frame was used instead.

Delimitation of putative independent evolutionary lineages

Single-locus genes provide useful information to generate preliminary hypotheses of species delineation [51]. Evolutionary processes such as introgression and incomplete lineage sorting and biological features such as dispersal ability and population sizes, however, may compromise the ability of single markers to infer species boundaries [52, 53, 54]. Therefore candidate lineages have to be subsequently validated by using multi-locus, multi-coalescent approaches, and further corroborated by the addition of phenotypic/ecological information [55].

The General Mixed Yule Coalescence model (GMYC) [56] was used to delimit coalescent groups (i.e. putative independent evolutionary lineages) within the complete *Titanidiops cox1* sequence data set due to the consistent amplification of this fragment across the individuals and its higher variability. The computer program BEAST was used to infer an ultrametric tree for the whole *cox1* data set defining a lognormal relaxed clock, with a single partition, under a GTR+Γ evolutionary model, the ucl.d.mean parameter set to 1 and selecting a constant population size coalescent tree prior [57]. Two independent runs of 5×10^7

generations were conducted remotely at the BIOPORTAL computer resource of the University of Oslo (<http://www.biportal.uio.no/>). Convergence between runs and correct mixing within each run were visualized with TRACER [58]. Individual runs were combined in BEAST accompanying program LOGCOMBINER. The first 10% of the generations of each run was discarded as a burn-in. A consensus chronogram was inferred with TREEANNOTATOR. The GMYC analysis was carried out in the R (<http://www.r-project.org>) environment using the SPLITS package [59].

Phylogenetic analysis

Phylogenetic inference was conducted under two different approaches: (1) by assuming a common underlying tree for the different genes (i.e. concatenation approach) and (2) by assuming independent gene trees and species tree (i.e. species tree/gene tree approach). The *cox1*, *16S*, *L1*, *nad1*, *28S*, *EF1 γ* , *H3* gene fragments of a single individual with the most complete sequences from each *Titanidiops canariensis* GMYC cluster identified above were concatenated in a single matrix using Geneious v. 5.3.6. [43]. The gaps were coded as presence/absence characters following the simple coding approach [60] as implemented in FastGap 1.2 [61], (available at http://www.aubot.dk/FastGap_home.htm). The *AL1-Hsp70* gene fragment was not included in the concatenated matrix because of the deep differences observed within individual alleles and the absence of data for Moroccan samples.

The best partitioning scheme and evolutionary model were selected using the greedy algorithm in the program PARTITIONFINDER [62]. The *L1* and *16S* genes were combined in a single partition.

The Bayesian inference analyses were conducted in MrBayes v. 3.1.2 [63] and run remotely at the CIPRES portal [64]. A ten-partition scheme with the corresponding evolutionary models as selected by PARTITIONFINDER and an additional restriction model for binary scored gaps were defined (see Table 1). Two independent runs of 5×10^7 generations with 8 MCMC (Markov Chain Monte Carlo) chains each, starting from random trees and resampling each 1000 generations were run simultaneously. The first 20% of the generations were discarded as a *burn-in* for the analyses. Convergence of the runs was assessed by monitoring the standard deviation of split frequencies (<0.01) with the help of the program TRACER v.1.5 [58], which was further used to assess correct mixing within each chain.

Maximum Likelihood (ML) analyses were conducted in RaxML v.7.2.8. [65]. Independent GRT+G+I substitution models were assigned to each partition of the ten-partition scheme (see above), and a binary model was applied to the gaps. The best maximum likelihood tree was selected from 100 iterations and support assessed with 1000 replicates of bootstrap resampling.

All trees were visualized and manipulated with the program FigTree v. 1.3.1 [66].

Table 1. Evolutionary models and partition schemes selected by PARTITIONFINDER for the different analyses conducted.

Concatenated mtDNA + nucDNA		Concatenated mtDNA time		Coalescent mtDNA + nucDNA	
Partition	Model	Partition	Model	Partition	Model
<i>cox1</i> 1 st	HKY+I+G	<i>cox1</i>	GTR+I+G	mtDNA	GTR+G
<i>cox1</i> , <i>nad1</i> 2 nd	K81+I+G	<i>16S-L1</i>	GTR+I+G	28S	HKY+I
<i>cox1</i> 3 rd	K81+G	<i>nad1</i>	GTR+I+G	<i>EF1γ</i>	HKY+I+G
<i>nad1</i> 3 rd	HKY+G			<i>H3</i>	K80+I
<i>nad</i> 1 st , <i>16SL1</i> , <i>H3</i> 3 rd	GTR+I+G			<i>AL1-Hsp70</i>	K80+G
<i>EF1γ</i> 1 st	JC+I				
<i>EF1γ</i> 2 nd	F81+I				
<i>EF1γ</i> 3 rd	K80+G				
28S	HKY+I				
H3 2 nd , 3 rd	K80+I				

Concatenated mtDNA time refers to concatenated analyses conducted with BEAST including informed substitution rate priors.

doi:10.1371/journal.pone.0115078.t001

Estimation of divergence times

Divergence time was estimated using two complementary approaches: concatenation and a coalescent-based approach. Time estimates were conducted in a Bayesian framework with the help of the program BEAST 1.7.4. [67]. The concatenation analysis only included mitochondrial data (*Cox*, *16S*, *L1* and *nad1*) to facilitate the comparison of *T. canariensis* divergence times with other Canarian ground dwelling spiders reported in the literature. Additionally, distant outgroups were removed from the analyses to reduce branch length disparity (i.e. only *Titanidiops* and *Idiops syriacus* samples were included). In an attempt to facilitate convergence, a simplified partition scheme by gene was implemented with corresponding substitution model provided from PARTITIONFINDER. All genes were set to share the same tree and a Yule speciation model was set as the tree prior. Preliminary model comparison using Bayes Factor based on Path Sampling/Stepping stone sampling methods [68] indicated that the alternative Birth-Death model did not provide a better fit to the data.

Because of the lack of fossil data and relevant biogeographic events, we relied on a spider specific mitochondrial substitution rate available in the literature [69]. A normal prior was assigned to the ucl.d.mean parameter of the lognormal relaxed clock, with initial and mean value 0.0127 and standard deviation 0.0045. Three independent chains of 5×10^7 generations were run and subsequently analysed using the same procedure as described above (see *Delimitation of putative independent evolutionary lineages* section).

To ascertain the timeframe of the evolution of *Titanidiops canariensis*, a multi-gene coalescent approach as implemented in the program *BEAST [70] was performed. All GMYC lineages of *T. canariensis* with at least two sequences per gene were included. The GMYC 1 clade from *Titanidiops* sp. from Morocco was used as outgroup. Similarly to the concatenated analysis, the partition scheme was simplified to speed up computation and facilitate convergence. Mitochondrial

genes were combined in a single partition and a single evolutionary model, lognormal relaxed clock and tree were defined for this partition. Conversely, independent models, lognormal relaxed clocks and trees were allowed for each nuclear gene. Along with mitochondrial substitution rate implemented in the concatenated analysis, a substitution rate for the *EF1 γ* was set to 0.00117/per site/million years (normal distribution prior ucl.d.mean=0.00117, sdev=0.00014) as recently estimated for mygalomorph spiders [71]. Uniform priors to the ucl.d.mean were assigned for the *28S*, *H3* and *AL1-Hsp70*, with lower and upper bounds 0.0001 and 0.0115, respectively, and starting value 0.001, under the assumption that the nuclear genes are about one order of magnitude slower than mitochondrial and generally no nuclear protein coding gene will show higher rates than the mitochondrial genes [71, 72]. Finally, we used the oldest subaerial age of Fuerteventura (22 My) [73] as a maximum bound for the tree root. Four independent runs of 100 millions of generations were run remotely on the CIPRES portal [64]. Results were monitored and analysed as already specified in the concatenated analysis.

Phylogeographic analysis

To infer the phylogeographic history of Canarian *Titanidiops*, we used a Bayesian discrete phylogeographic approach [74] as implemented in BEAST. The Bayesian Stochastic Search Variable Selection (BSSVS) was used to identify the rates, i.e. colonisation pathways, that were frequently invoked to explain the diffusion process [74]. We defined 5 discrete biogeographic areas corresponding to the main independent volcanic edifices that conform the present day emerged parts of the Eastern Islands, namely (from south to north) the Southern (SVC), the Central (CVC) and the Northern Volcanic Complexes (NVC), in Fuerteventura, and Los Ajaches (AJA) and Famara (FAM) in Lanzarote [75] (Fig. 1).

We constructed two new data sets to run the phylogeographic analyses, one with the mtDNA data and a second one with the nuclear *EF1 γ* , in both cases including all Canarian specimens. Unfortunately, all the analyses conducted on the nuclear partition reported infinite likelihoods, probably due to the very low divergences among the sequences. Therefore, phylogeographic analyses were restricted to the mtDNA partition. The discrete phylogeographic analyses were run under the uncorrelated lognormal molecular clock for the mtDNA data, specifying the same normal prior for the ucl.d.mean as above (*Estimation of divergence times*), and a strict clock model for the location trait. The corresponding partition scheme and evolutionary models for the mtDNA were selected with PARTITIONFINDER, and the asymmetric substitution model was assigned to the location. The new matrix included a mix of coalescent (within GMYC clusters) and speciation (between GMYC clusters) level divergences. Therefore we conducted the analyses using the *BEAST option, assigning individuals to their corresponding GMYC cluster but linking all genes to the same clock model and tree. All other settings were identical to those used in the dating analyses.

BPP

The status of mitochondrial GMYC clusters as candidate species was further tested in a Bayesian multi-species coalescent framework using the species delimitation method in the program BPP 2.2 [76, 77]. This method calculates the posterior probabilities of alternative species delimitation models using a multispecies coalescent approach and interprets gene tree incongruence as the result of ancestral polymorphism.

Following Leaché & Fujita [78], we used the rjMCMC algorithm 0 with the fine-tuning parameter ε set to 15.0. Each species delimitation model was assigned an equal prior probability. Because of the volcanic nature of the Canary Islands, and in the absence of information about the ancestral population size of the target organism, we assumed an evolutionary scenario where the colonising ancestral population was of a small size due to the frequent bottlenecks associated with volcanism and island colonisation ($\theta_s \sim G(2, 2000)$). The effects of alternative species divergence time scenarios on species delimitation were tested by implementing either shallow ($\tau_0 \sim G(2, 2000)$) or deep divergence priors ($\tau_0 \sim G(1, 10)$). The species tree obtained in the *BEAST analysis was used as the fixed topology. The species delimitation analyses were restricted to those clades determined with high support (i.e., $p > 0.95$) in the *BEAST analyses (see results). The convergence and sensitivity of the results to the initial condition were assessed by running three independent chains for each parameter combination, each time starting with a different species delimitation model: one that lumped all candidate species into a single species, one that considered an intermediate number of species and one that considered the full range of species.

Population structure

Standard genetic diversity indices, including the nucleotide (π) and haplotype diversity (H) indices, were calculated in DnaSP 5.10.1 [48] for *cox1*, *EF1 γ* , *H3* and *AL1-Hsp70* for all GMYC clades consisting of at least two individuals. Additionally, the values were also calculated for the 28S 16S + *L1* and *nad1* fragments in the dataset, the Moroccan *Titanidiops* and *T. canariensis* samples and the two *T. canariensis* main clades determined in the *BEAST analyses.

Allele networks were constructed in search for the possible geographic patterns in the allele distribution in *EF1 γ* and *AL1-Hsp70* using the minimum spanning tree method in the program HapStar [79] based on the output provided by Arlequin [80].

We looked for patterns of isolation-by-distance in the Canarian samples using the online version of the program IBDWS 3.23 [81]. The *cox1* F_{ST} pairwise estimates calculated in IBDSW from raw sequences and the geographic distances between the locations obtained in Geographic Matrix Distance Generator v. 1.2.3 (Ersts, American Museum of Natural History, Center for Biodiversity and Conservation, http://biodiversityinformatics.amnh.org/open_source/gdmg) were correlated in three sets of analyses: one including all *T. canariensis* samples and the other two using the two main clades identified in *Beast.

Results

Sampling, sequencing and recombination testing

Information about specimens, localities and sequence GenBank accession numbers are listed in [S1 Table](#), and the localities are shown in the map in [Fig. 1](#). A total of 100 specimens were sequenced in the present study. The following gene fragments were obtained for *Titanidiops*: the mitochondrial *cox1* (673 bp, 231 variables), *16S-L1* (600 bp, 177 variables) and *nad1* (382 bp, 149 variables) and the nuclear *28S* (762 bp, 22 variables), *EF1 γ* (844 bp, 52 variables), *H3* (347 bp, 46 variables) and *AL1-Hsp70* (606 bp, 86 variables). No recombination was detected within any of the gene fragments used in this study.

GMYC-based lineage delimitation

The complete *cox1* data matrix, including 98 *Titanidiops* specimens from the Canaries and Morocco, was analysed using the single-threshold option of the GMYC algorithm, which was shown not to be significantly worse than the multiple-threshold option ($p=0.23$). The GMYC algorithm identified 32 entities/clusters (CI: 27–34) ($p=4.6 \times 10^{-9}$), of which 9 were Moroccan and 23 were from the Canary Islands ([S1 Table](#), [Fig. 3](#)). In most cases, the GMYC clusters corresponded to single localities, and each locality included a single GMYC cluster (62%). Exceptions to this pattern included 4 instances of GMYC clusters found in more than one locality, usually including one or more nearby localities, and 5 instances of localities with more than one GMYC, usually involving closely related clusters. Interestingly, two different GMYC clusters belonging to distant clades (G20 and G10) were sampled from locality 6, in central Fuerteventura.

Phylogenetic analyses

All genes except *AL1-Hsp70*, which could only be reliably amplified and sequenced in the Canarian specimens, were concatenated with the outgroup sequences in a single matrix for subsequent Bayesian and ML tree inference. The concatenated data matrix consisted of 3,583 bp (some alignment positions with a high proportion of missing data were removed) and 32 binary coded gaps scored for 51 terminals. The *Titanidiops canariensis* lineages were represented by single representatives of each GMYC cluster to increase the speed of the analyses. The partition scheme and corresponding evolutionary models are summarised in [Table 1](#).

The Bayesian and maximum likelihood (-lnL 15343.170107) analyses of the concatenated data matrix resulted in similar tree topologies, although the Bayesian inference yielded higher clade supports ([Fig. 4](#)). Both analyses supported the reciprocal monophyly of *T. canariensis* and a clade comprising *Idiops syriacus* and the Moroccan *Titanidiops* lineages. The internal topology of *T. canariensis* was well supported and highly congruent between the methods. Conversely, most relationships within the deeply divergent Moroccan *Titanidiops* lineages were poorly supported.

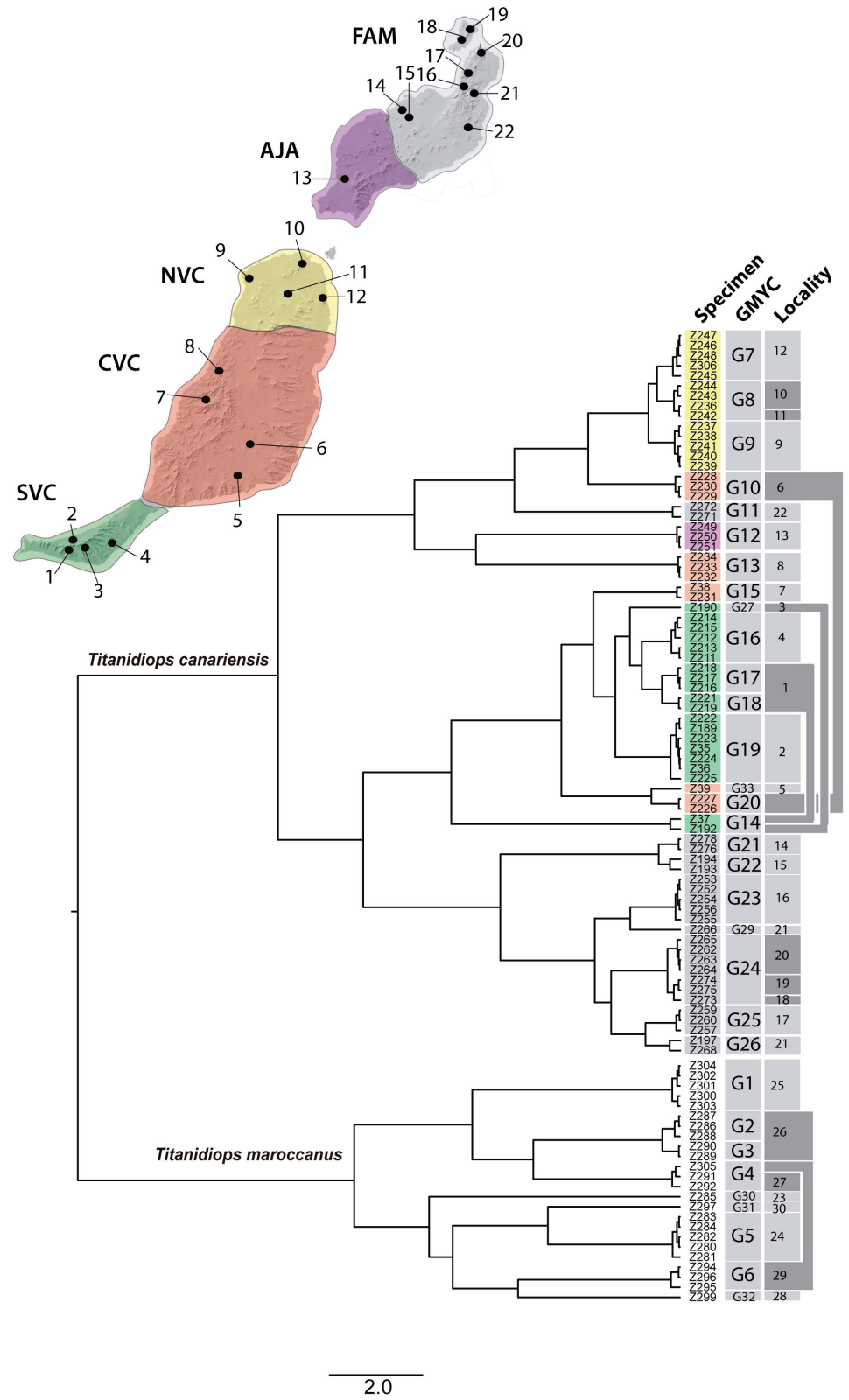

Fig. 3. Ultrametric *cox1* BEAST tree. GMYC column: clades identified as independent GMYC clusters in the SPLITS analyses, labelled as in S1 Table. Locality column: localities where the respective GMYC cluster was collected. Localities in dark grey correspond to those either including more than one GMYC cluster or those where the GMYC cluster was found in an additional locality (connected by bars). Terminal colour codes represent geographic location as shown in the map. SF: southern Fuerteventura (Jandia Peninsula), CF: central Fuerteventura, NF: northern Fuerteventura, SWL: south-western Lanzarote, NEL: north-eastern Lanzarote (includes La Graciosa islet).

doi:10.1371/journal.pone.0115078.g003

Both analyses indicated a well-supported clade (hereafter referred as the JSF clade) that includes the specimens from the Jandia Peninsula in southern Fuerteventura except for the individual Z37, which constituted an independent lineage, along with some specimens from central Fuerteventura. These Fuerteventura lineages were shown to be sister lineages to the remaining Canarian representatives, albeit with low support. Similarly, most Lanzarote specimens

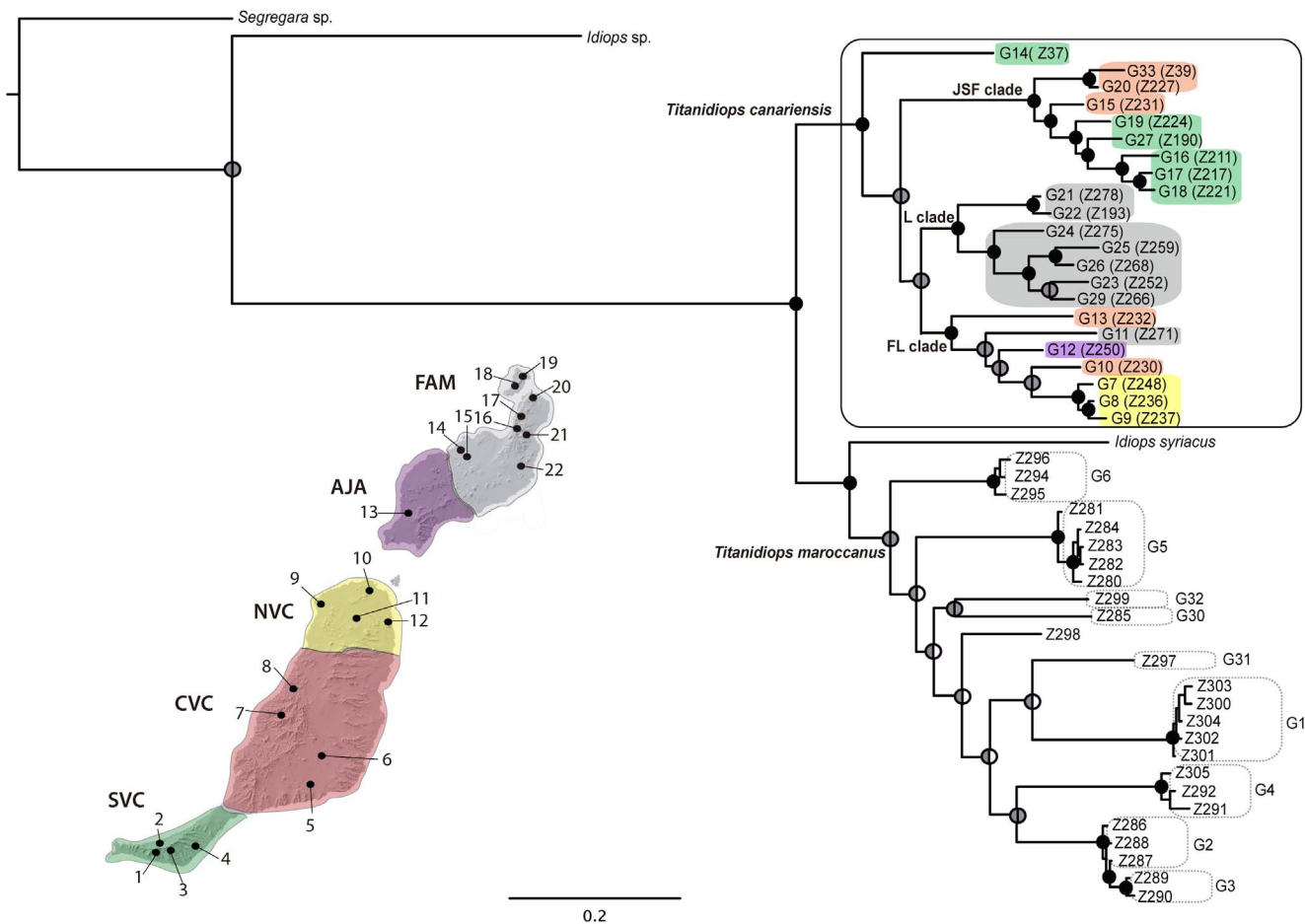

Fig. 4. Topology obtained in the concatenated Bayesian analyses. *Titanidiops canariensis* is represented by single representatives from each GMYC cluster identified (Fig. 3, S1 Table). *T. maroccanus* GMYC clusters are highlighted in boxes. Dots on nodes denote support as follows: left semi-circles are Bayesian posterior probabilities (PP) and right ones are maximum likelihood bootstraps, black=PP>0.95, ML bootstrap support >80%, grey = clade determined but with support values less than the thresholds above, white = topology not determined. Terminal colour codes as in Fig. 3.

doi:10.1371/journal.pone.0115078.g004

formed one well-supported clade (hereafter referred as the L clade), including two reciprocal geographic clades (northeast and southwest), which were sisters, albeit with low support, to a clade (hereafter referred as the FL clade) that includes representatives from northern and central Fuerteventura and two additional Lanzarote lineages, one from the southwest and one from the northeast. Although the internal relationships of the last clade were poorly supported, the central Fuerteventura lineage G13 (Z232) was determined to be a sister group to all remaining lineages within the clade.

Estimation of divergence times

Overall, the tree topology and the clade supports were similar to those found in the Bayesian and ML analyses. The root was assigned to the split between *T. canariensis* and the clade formed by the Moroccan *Titanidiops* lineages and *I. syriacus* (Fig. 5), and it was estimated to have occurred approximately 12 million years ago (Ma) (12.37, 24.65–6.41 Ma). The most recent common ancestor (TMRCA) of *T. canariensis* was estimated at 8.08 Ma (16.01–4.16 Ma). The diversification of the JSF clade began 2.86 Ma (5.74–1.39 Ma), while the L clade and the FL began diversifying earlier, 6.98 Ma (13.82–3.57 Ma).

The split between *Titanidiops maroccanus* and *I. syriacus* was traced back to approximately 11 Ma (10.97, 21.79–5.41 Ma), although this relationship was not well supported. Diversification of the deeper *T. maroccanus* lineages occurred from the late Miocene to the early Pliocene. As in the previous analyses, most relationships within the Moroccan *Titanidiops* remained unresolved.

Special caution should be exercised when interpreting time estimates since they were based on substitution rates obtained from studies analysing interspecific level divergences. It has been shown that the extrapolation of rates across the population-species boundary may overestimate molecular time-scales [82, 83] (but see [84]). In this particular case, however, the pervasive effects of interspecific substitution rates may have been attenuated by the use of single representatives for each mtDNA coalescent clusters (i.e. GMYC clusters).

Coalescent approach

The coalescent approach resulted in a similar topology to the concatenated analyses but with lower support. The resulting *T. canariensis* species tree (Fig. 5) was divided into two well-supported clades, one corresponding to the JSF clade determined in the previous analyses, and the other one (hereafter referred to as the A clade) included the remaining individuals, which were also determined in the previous analysis albeit with lower support. The internal relationships of the JSF clade corresponded approximately to those found in the previous analyses. Conversely, clade A showed major lineage rearrangements compared to the previous analyses, mostly involving lineages G11, G12 and G13. Lineage G11, which was shown to be part of the clade FL in the previous analyses, was determined to be a sister lineage to the remaining lineages in clade A. The lineage

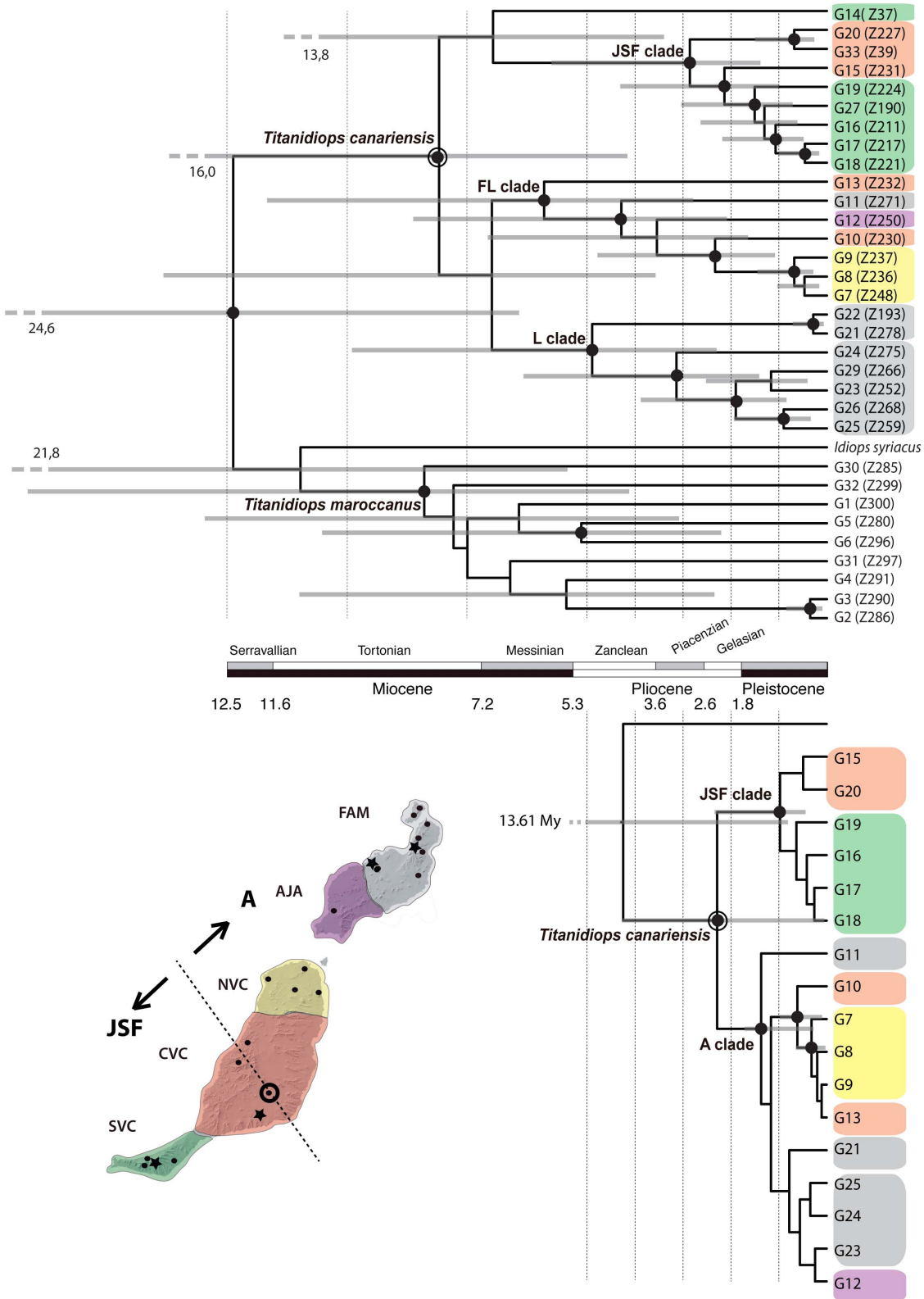

Fig. 5. Chronograms obtained with (a) the concatenated approach using BEAST and with (b) the multispecies coalescent (species tree) approach using *BEAST. Dots on nodes denote Bayesian posterior probabilities above 0.95. Node bars indicate the 95% HPD confidence intervals of the divergence time. The common x-axis is time in million years (My). Terminal colour codes are as in the figure inset. Samples from the localities marked as stars on the map were only included in the concatenated approach.

doi:10.1371/journal.pone.0115078.g005

G12, also shown to be part of the FL clade in the previous analyses, was nested within the former L clade. Finally, lineage G13, which was formerly supported as the first split within the FL clade, was nested with high support within a clade formed by the lineages from northern Fuerteventura. Overall, these differences resulted in more geographically congruent clades.

Lineage divergence times were much younger than those determined in the mtDNA concatenated analysis. The origin of the *T. canariensis* stem was placed at 4.25 Ma (13.6–0.8 Ma), while its TMRCA dated back to 2.29 Ma (4.28–0.05 Ma). The diversification of clade A began approximately 1.36 Ma (1.71–0.27 Ma). The origins and diversification of the main geographic lineages, namely the JSF clade, the central-northern Fuerteventura clade and the Lanzarote clade, occurred approximately 1 Ma (2.34–0.44 Ma)

Phylogeographic analyses

Results of the discrete phylogeographic analyses are summarized in [Fig. 6](#). The extant *T. canariensis* diversity most likely originated in northern Lanzarote (FAM). However, this result is to be considered as tentative due to the low support for the basal node and the low posterior probability of the area assignment. A subsequent split separated central-southern Fuerteventura (SVC, CVC) and northern Lanzarote (FAM) lineages. Southern Lanzarote (AJA) and northern Fuerteventura (NVC) were colonised from northern Lanzarote (FAM). Central Fuerteventura (CVC) was probably colonised at least two times independently, from northern Lanzarote and from Southern Fuerteventura (SVC).

BPP

The following lineages, delineated with high support in the *BEAST analysis, were included in the species delimitation analyses: G15+G20 (candidate species 1, sp. 1), G16-G19 (sp. 2), G11 (sp. 3), G10, (sp. 4) and G7-G9+G13 (sp. 5). In addition, although not supported, the clade G21+G23-G25 (sp. 6) was also tested, as it was the sister group of a well-supported clade and similar in age to the remaining clades analysed.

Under the first scenario tested, i.e., shallow divergences, all runs starting from $K=1$ and $K=2$ supported (i.e., a posterior probability of the split >0.95) a two species hypothesis, in agreement with the basal split between the JSF and A clades (sp1+sp2 and sp3+sp4+sp5+sp6). Runs starting from $K=3$ resulted in three delimited species because clade A was further divided into sp3 and sp4+sp5+sp6.

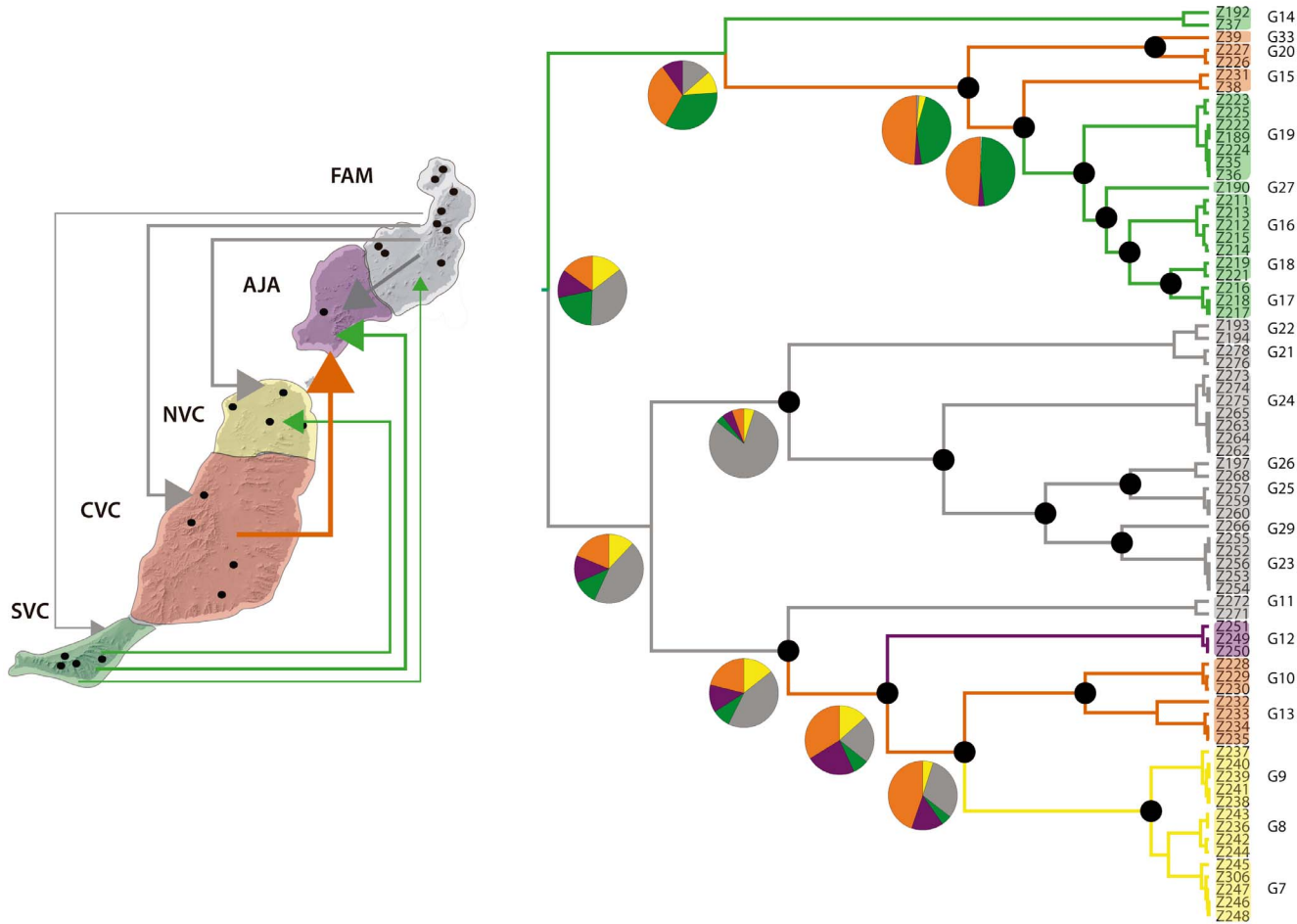

Fig. 6. Bayesian ancestral range reconstruction and colonisation history of Canary *Titanidiops* based on mtDNA markers. Black dots identify nodes with Bayesian posterior probabilities (PP) >0.95 (all nodes >0.5). Branches coloured as the ancestral range with highest marginal probability for each lineage as inferred in BEAST. Node pie charts represent marginal probabilities for alternative ancestral ranges. Colonisation routes identified by BSSVS are shown on the map with line width proportional to the rate value.

doi:10.1371/journal.pone.0115078.g006

Finally, runs under K=4, K=5 and K=6 supported a five species hypothesis, sp1+sp2, sp3, sp4, sp5 and sp6 (Fig. 7). In all cases, sp1 and sp2 were lumped into a single species. The results of the second scenario, deep divergences, were directly dependent on the selected K values. These results were identical to the defined starting models.

Population analyses

Standard genetic diversity indices, nucleotide diversity (π) and haplotype diversity (H), were calculated for the *cox1*, *EF1 γ* , *H3* and *AL1-Hsp70* genes for each GMYC lineage comprising two or more individuals from the entire *Titanidiops* dataset, for *T. canariensis*, *T. moroccanus* and for the JSF and A clades. The results are summarised in S2 Table.

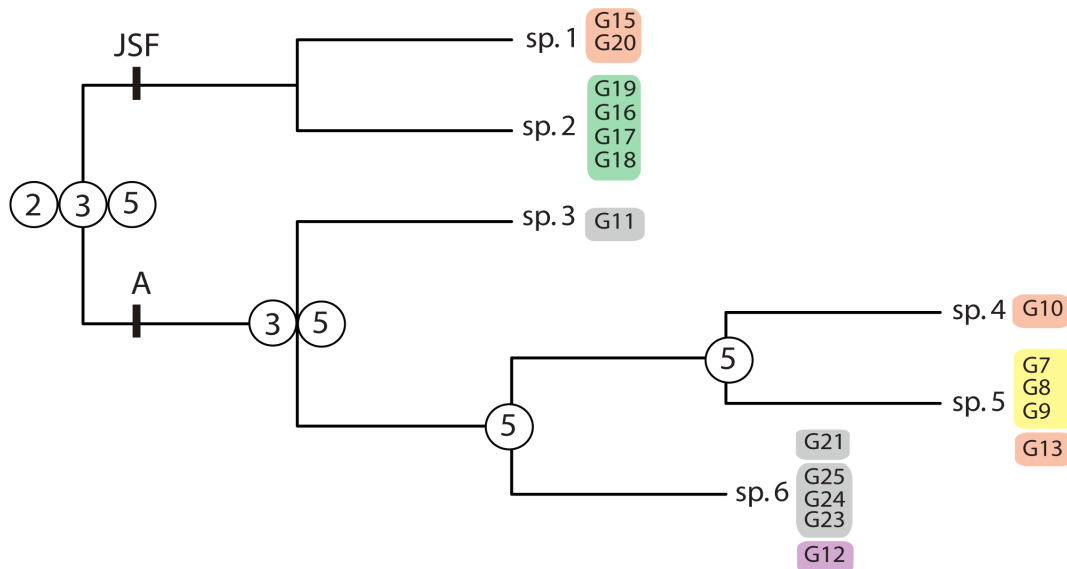

Fig. 7. Multi-locus Bayesian species delimitation with BPP. Only results obtained under the small population sizes ($\theta_s \sim G(2, 2000)$) and shallow divergence ($\tau_0 \sim G(2, 2000)$) scenarios are shown. Circles on nodes indicate lineages (descendants) supported as independent evolutionary lineages (i.e., species) and the total number of independent lineages supported under alternative models of number of starting species (K). Terminal colour codes as in Fig. 3.

doi:10.1371/journal.pone.0115078.g007

The *T. canariensis* *EF1 γ* allele network (S1 Figure) included 27 unique alleles. The two most common alleles, which differed by a single substitution and were shared by 18 and 12 individuals, were collected from all geographical zones. Overall, the network was congruent with the main mtDNA lineages, assuming the most frequent alleles were shared across lineages due to ancestral polymorphism.

The resulting *AL1-Hsp70* network (S2 Figure) contained 45 distinct alleles. The highest allele diversity was found among the northern Lanzarote samples (20 alleles), and the northern Fuerteventura samples showed the lowest (3 alleles). The remaining three geographic zones presented a moderate number of alleles (central and southern Fuerteventura had 10 alleles, respectively, and south-western Lanzarote had 7). Unlike the *EF1 γ* network, the *AL1-Hsp70* one had little geographic structure, and most mtDNA lineages were not determined. The JSF clade was an exception, and the alleles belonging to individuals carrying this mtDNA lineage were all closely related. A group of alleles found mostly in northern Lanzarote (one from southern Lanzarote) was separated from all remaining alleles by at least 14 missing mutations.

Isolation by distance

There was no significant correlation between genetic and geographic distances, either for all *T. canariensis* samples together or for any of the two main lineages (JSF and A) ($r(P) = -0.0036 (0.5746), 0.2879 (0.3391), -0.0710 (0.7247)$, respectively).

Discussion

Mygalomorph spiders on the oceanic islands

Mygalomorph spiders are notoriously absent from oceanic archipelagos, most likely due to their low dispersal abilities [23, 24, 26, 85]. The very few reported exceptions include members of the ctenizid genus *Ummidia* in the Caribbean, one of the few mygalomorphs that uses airborne dispersion. Several species of the family Barychelidae, presumably without ballooning capability, are found on remote oceanic archipelagos in the Pacific [86, 87, 88], but no explicit biogeographic hypotheses have been put forward to explain their origin. Here, we provide, for the first time, dated phylogenetic information to decipher the origins of an oceanic mygalomorph.

In spite of the relatively short distance between the Canary Islands and northern Africa, approximately 110 km at the narrowest point, the well-supported monophyly of the Canarian lineages suggests a single event of colonisation of the Canary Island by *Titanidiops*. Although the mechanism by which *Titanidiops* colonised the Canaries remains speculative, it has been suggested that the ground-dwelling spider *Dysdera* colonised the Canary Islands from the neighbouring north-eastern African coast by transporting itself on floating islands [2]. Some of the *Titanidiops* localities sampled in Morocco are distributed around the valley of the Sous River and it is possible that in the more humid climate of the past [89, 90], the river had torrential currents, facilitating the formation of large mats that may have acted as rafts for ground-dwelling arthropods. In addition, sea level regressions [91] would have further facilitated dispersal by reducing the distance from the continent, as suggested by the arrival of the extinct endemic rodent *Malpaisomys* [92].

A large gap was observed between the timeframes of *Titanidiops* diversification determined from only the concatenated mitochondrial data and from the multi-locus species tree approaches. In general, longer divergence time estimates are expected from gene trees because a fraction of gene divergence may pre-date population/species divergences [93, 94]. There is ample empirical evidence that the use of species-tree approaches usually results in younger estimates of species divergence times [95, 96, 97], sometimes as much as three times younger [98]. In our study, the species tree estimates of the timing of most recent common ancestor of the Canarian *Titanidiops* (2.29 Ma, 4.28–0.05 Ma) were about half as young as the mtDNA gene estimates (8.08 Ma, 16.01–4.16 Ma). Differences in time estimates under both approaches may be exacerbated in the case of large ancestral populations [96] or in the presence of gene flow among lineages [95]. Because of the inherently small populations involved in colonisation events, in the case of *Titanidiops*, the existence of gene flow may provide a better explanation. The effect of such events may also explain some of the incongruences observed in the *AL1-Hsp70* allele network (S2 Figure).

The mismatch between the estimated times using the two approaches, either during the Miocene or in the Pliocene, hinders the proposal of a geological scenario for the colonisation of the islands. Although the random nature of the

colonisation process could explain the absence of *Titanidiops* from the western Canaries, the strong environmental differences between the arid and low-lying Eastern Canaries and the lush and elevated Western Canaries may suggest specific ecological or habitat preferences. If *Titanidiops* are better suited to the present day environmental conditions in the Eastern Canaries, its arrival to the island probably occurred after the onset of such conditions.

It is worth noting that there are other cases of eastern Canarian endemic lineages with northern African close relatives, especially among plants [99]. Examples of faunal connections include the spider *Dysdera lancerotensis* [100], the *Calathus* beetles [12], the *Chalcides* skinks [101], the *Tarentola* geckos [11] and the fossil rodent *Malpaisomys* [92]. Available time estimates for these lineages suggest a mid-Pliocene to early Pleistocene colonisation of the Eastern Canaries. Interestingly, this timeframe coincides with the onset of a major dryness event in the region following the establishment of the cold Canarian sea current ~4 Ma [102]. Our species-tree estimates of the Canarian *Titanidiops* stem fits well with the former scenario, which would suggest a pre-adaptation to xeric conditions. However, the time estimates in the cited studies were obtained either from single mitochondrial genes or from gene concatenation.

Our concatenated *Titanidiops* divergence time estimates are much older, tracing back to the Miocene epoch, and are closer to the values reported for the Canarian lineages that have undergone species radiations, such as the *Pholcus* [103] and most of the *Dysdera* [4, 104] spiders and the *Gallotia* lizards [105]. Similarly, the coalescent time of *Titanidiops* (4.25 Ma, 13.60–0.80 Ma) pre-dates most values reported in the literature for Eastern Canaries endemics, including the lizard *Gallotia atlantica* (1.9 Ma, confidence interval 3.3–1.3 Ma) [7], the darkling beetle *Hegeter politus* and the spiders *Dysdera lancerotensis* (1.5 Ma, 2.3–0.7 Ma) [100], *D. nesiotis* (0.8 Ma, 1.1–0.53 Ma) and *D. alegranzaensis* (0.83–0.4 Ma) [5].

Further support for the old (Miocene) colonisation of the Canaries by *Titanidiops* may come from the observation that the sampled population from the continental source, Morocco, formed a monophyletic group, indicating that the continental lineages that gave rise to the island populations may have gone extinct and, hence, that the colonisation preceded the current diversification of *T. maroccanus*. If *T. canariensis* had colonised the Canaries in much more recent times, as suggested by the multi-coalescent analyses, there would have been higher chances to find some descendants of the ancestral continental stock, which would have rendered the continental lineages paraphyletic regarding the island ones.

How many species of *Titanidiops* inhabit the Canary Islands?

Mygalomorph spiders are phenotypically conservative and pose a challenge to classical taxonomy. The application of molecular tools to investigate phylogeographic patterns in this group has uncovered a great amount of hidden diversity [23, 36, 85, 106, 107, 108]. However, because of their low dispersal capability and burrow fidelity, mygalomorph spiders tend to form clustered aggregations [109, 110], which usually lead to extensive genetic structures [24, 27, 106, 111],

making it difficult to distinguish between fragmented populations and independent evolutionary lineages [26].

Although it is generally agreed that species delimitation should be based on the integration of multiple lines of evidence (i.e., genotypes, phenotypes, ecology) [112], novel statistical approaches for the quantitative assessment of species boundaries mostly focus on genetic data [113, 114]. Among the multiple methods developed to determine species boundaries based on multi-locus data, the Bayesian multi-species coalescent model in the program BPP has become increasingly popular [26, 78, 115, 116, 117, 118, 119]. Although the method assumes no gene flow, efficient performance has been proven with the low gene flow level of 0.1 migrants per generation [120].

In this study, we have applied the BPP method to validate whether the large number of genetically divergent lineages revealed by the GMYC approach corresponds to distinct evolutionary lineages. We tested two alternative scenarios, corresponding to either shallow or deep divergences between candidate species. Because of the dynamic nature of volcanic landscapes, involving recurrent extirpations and recolonisations of populations, and the low vagility of mygalomorph spiders, small ancestral population sizes were assumed for both scenarios. However, given the inconsistent results from the deep divergences scenario and the relatively recent estimates from the species-tree approach for the diversification of *T. canariensis*, which were mostly confined to the Pleistocene, we argue that the scenario assuming shallow divergences between the candidate species is probably the most appropriate.

Our results are sensitive to the starting species number model (K), which, to the best of our knowledge, has not been reported in any previous study. The basal split of *T. canariensis* into two species was the only consistently supported alternative across all starting species models. Higher numbers of species were only supported by particular K values. The BPP method has been found to over split species diversity, most likely because it does not integrate over the species tree parameter space [26]. Here, we take a conservative approach and propose that *T. canariensis* includes two distinct species.

Interestingly, although the two putative species are, for the most part, geographically isolated, they do overlap in at least one locality, suggesting similar habitat preferences. Although the results do not show clear evidence of gene flow, most shared alleles may be explained by ancestral polymorphism, a larger sample and more variable nuclear markers would be required to assess the actual level of genetic isolation.

The “JSF” species was found in all localities sampled on the Jandia peninsula. This massif is effectively isolated from the rest of Fuerteventura by a low-elevation isthmus, covered by aeolian sands, which explains the presence of several examples of vicariant species on the peninsula [121]. However, it was also found in localities across the isthmus that do not show any obvious geographic discontinuities with the populations of the second species, including the co-occurring locality. The branching pattern determined in the better-sampled concatenated analyses is compatible with at least two rounds of back-and-forth

colonisation between the main island and Jandia. Therefore, the north-wise displacement of the contact zone between the two putative species could be explained by a secondary colonisation of the Fuerteventura main island from a lineage originally isolated in the peninsula.

It is not strange that all the specimens collected in the present study were either females or juveniles, because they were mostly extracted from burrows, which adult males are known to abandon after the final moult. In fact, only 3 male specimens of *T. canariensis* collected in pitfall trap in Jandia are known at present. Preliminary observations revealed subtle differences in morphology between the putative species; however, in the absence of male material from localities throughout the Eastern Canaries, we have refrained from formally describing a new species.

Phylogeographic patterns in *T. canariensis*

As was expected based on former phylogeographic studies on trap-door spiders [26, 27, 111], a high number (23) of narrowly distributed mtDNA GMYC clusters, found frequently in single localities, were determined in *T. canariensis*. The GMYC clusters were often formed by individuals sharing identical or very closely related haplotypes (see S2 Table for details). This observation corroborates the tendency of *T. canariensis* to form aggregates, which has also been reported in other trap-door spiders such as the genus *Cyrtocarenum* from the family Ctenizidae [109]. These results provide further support for the limited dispersal ability of trap-door spiders. Although low vagility usually promotes isolation by distance, which has been suggested to play an important role in speciation in mygalomorph spiders [23, 36, 85, 106, 107, 108], there was no evidence of such a pattern in *T. canariensis*. The explanation for this lack of correlation may be found in the dramatic relief of the islands. Close localities are frequently separated by steep ridges or deep valleys, which most likely represent an effective barrier to dispersal.

In spite of its low dispersal ability, *T. canariensis* successfully spread through the Eastern Canary Islands. The Bayesian phylogeographic analysis identifies northern Lanzarote (FAM) as the ancestral range for *T. canariensis* and suggests at least two independent colonisation of Fuerteventura and probably a back colonisation of southern Lanzarote from Fuerteventura. Similar complex phylogeographic patterns within Lanzarote and between Lanzarote and Fuerteventura have been reported in other Eastern Canaries endemic taxa [5, 7, 100] and have been explained as the consequence of frequent population extinctions due to lava flows and the recurrent connections of the two islands during Neogene marine transgressions. It is noteworthy that one of the Lanzarote lineages includes a locality in the Zonzamas area (G11, locality 22), which has been identified as a refugium during episodes of volcanic activity [3, 5, 7].

Our results also suggest a recent colonisation of La Graciosa from Lanzarote, as samples from La Graciosa belong to the same GMYC cluster (G24) as those from the nearby locality of Mirador del Rio in Lanzarote. La Graciosa is separated from Lanzarote by a narrow seaway approximately 2 km wide and of shallow water, and

most of the shelf connecting the islands was exposed during the Pleistocene sea level oscillations [18], facilitating terrestrial dispersal between the two islands. This pattern differs from that observed in *D. lancerotensis*, for which La Graciosa populations seem to have originated from the northern islet of Alegranza [100]. The La Graciosa populations of *D. alegranzaensis*, conversely, show genetic affinities with both their Alegranza and Lanzarote populations [5].

Insights into continental *Titanidiops* diversity

Although determining the diversity and phylogenetic relationships of the continental *Titanidiops* were beyond the scope of the present study, our results provide some insights into the evolutionary patterns of *T. maroccanus*. Several highly divergent lineages were identified within *T. maroccanus*, showing a similar diversification timeframe to that estimated for *T. canariensis*, which may suggest the existence of cryptic species in Morocco. The divergence times estimated within *T. maroccanus* are far older than those reported in any other organism inhabiting the region. The basal split into the two main lineages of the wolf spider species complex *Lycosa oculata*, which comprises five putative species, occurred approximately 3.26 Ma, while present day species diversified between 2.96 to 1.51 Ma [122]. Similarly, most genetic diversity within Moroccan reptile species has been dated to the period of Pleistocene climatic oscillations (starting at 2.3 Ma) [123, 124].

The concatenated analyses supported the sister group relationship of the Moroccan *Titanidiops* lineages with *Idiops syriacus* (O.P. Cambridge 1870). Interestingly, *I. syriacus*, although originally described as *Idiops* (Perty 1833), was transferred to the genus *Titanidiops* by E. Simon [125], where it remained until Raven [22] synonymised both genera. When the genus *Titanidiops* was re-erected by J. Wunderlich [34, 35], the placement of *I. syriacus* and other former members of *Titanidiops* was not indicated. Interestingly, in the original description of *T. maroccanus*, Simon had already indicated that *I. syriacus* was the most similar species to the Moroccan *Titanidiops* [126]. Our results confirm this observation. However, additional representatives of the genus *Idiops*, and other genera within the family Idiopidae will be required to establish the phylogenetic limits of the genus *Titanidiops* and generic placement of *I. syriacus*.

Interestingly, the distribution of *Titanidiops* closely matches the continental floristic disjunction known as the “Rand” pattern [127, 128]. Many plant lineages show disjunct distributions between Macaronesia/northwest Africa, the Horn of Africa/southern Arabia and east/south Africa. A vicariant hypothesis was put forward to explain this pattern, which would be the result of the partial extinction of an ancient widespread African flora driven by post-Miocene aridification [129]. Recent analyses, however, suggest that dispersal may have also played an important role in shaping diversity in some of the areas involved [128]. The inclusion of the East-African *Titanidiops* species in future analyses will enable to test alternative hypothesis on the origin of the “Rand” biogeographic pattern in invertebrates.

The sister group relationship of *T. maroccanus* and *I. syriacus* has important implications for inferring the origins of the Canarian *Titanidiops*. The origin of *T. maroccanus* postdates the split of *T. canariensis* from their common ancestor and, most likely, the colonisation of the Canary Islands. This observation suggests that present day Moroccan diversity may be the result of a secondary colonisation of the region by the *Titanidiops* lineage. Alternatively, the Canaries could have acted as the source area for the subsequent colonisation of the continent, following a west to east progression pattern. Back colonisation of the continent from the Macaronesian islands has been documented in several groups, including plants, birds and invertebrates [130, 131, 132].

Conclusions

T. canariensis colonised the Canary Islands once, presumably from northern Africa, although no closely related Moroccan *Titanidiops* lineage has been detected. The time of colonisation remains undetermined, mostly due to the discrepancy between the time estimates obtained with the concatenated and the species tree approaches. Several lines of evidence, however, point towards a Miocene origin. A complex phylogeographic pattern was revealed, involving two independent colonisations of Fuerteventura from the ancestral range on northern Lanzarote and probably a back colonisation of southern Lanzarote from Fuerteventura. Volcanic activity may have contributed to the determined geographic patterns of genetic diversity, which further supports the existence of a volcanic refugium in the Zonzamas area in west-central Lanzarote. Our results are compatible with the existence of at least two species in the Canaries, one inhabiting the Jandia Peninsula and southern Fuerteventura and the second ranging from central Fuerteventura to northern Lanzarote. The two species co-occur in at least one locality.

Several highly divergent lineages were also detected within *T. maroccanus*, most likely representing cryptic species. In this study, a close phylogenetic affinity between the Moroccan *Titanidiops* lineages and *Idiops syriacus* was also uncovered, in agreement with the previous placement of *I. syriacus* in the genus *Titanidiops*, which suggests either a different origin for the Canarian and the present day Moroccan lineages of *Titanidiops*, or a back colonisation of the continent.

Supporting Information

S1 Figure. EF1 g allele network. Circle size is proportional to the allele frequency. Small filled circles represent missing alleles. Each allele is labelled with the individuals and GMYC cluster in which it was found. Asterisks indicate samples from the single locality (6) where the two putative species co-occurred (G10, G20).

[doi:10.1371/journal.pone.0115078.s001](https://doi.org/10.1371/journal.pone.0115078.s001) (TIF)

S2 Figure. *AL1-Hsp70* allele network. Circle size is proportional to the allele frequency. Small filled circles represent missing alleles. Each allele is labelled with the individuals and GMYC cluster in which it was found. Asterisks indicate samples from the single locality (6) where the two putative species co-occurred (G10, G20).

[doi:10.1371/journal.pone.0115078.s002](https://doi.org/10.1371/journal.pone.0115078.s002) (TIF)

S1 Table. Specimen information, locality data and GenBank accession numbers.

[doi:10.1371/journal.pone.0115078.s003](https://doi.org/10.1371/journal.pone.0115078.s003) (DOC)

S2 Table. Standard genetic diversity indices, nucleotide diversity (π) and haplotype diversity (H) of the *cox1*, *EF1 γ* , *H3* and *AL1-Hsp70* genes for each GMYC lineage formed by two or more individuals for the entire *Titanidiops* dataset, *T. canariensis*, *T. maroccanus* and the JSF and A clades.

[doi:10.1371/journal.pone.0115078.s004](https://doi.org/10.1371/journal.pone.0115078.s004) (DOC)

Acknowledgments

We are thankful to E. Planas and C. Ribera for the assistance during the fieldwork, to N. Macías-Hernández for kindly providing us with additional *T. canariensis* samples and to M. Forman for providing us with the specimen of *Segregara* sp. Two anonymous reviewers provided insightful comments that greatly improved the final version of the manuscript.

Author Contributions

Conceived and designed the experiments: MA VO. Performed the experiments: VO. Analyzed the data: VO MA. Contributed reagents/materials/analysis tools: MA. Wrote the paper: VO MA.

References

1. Emerson BC (2002) Evolution on oceanic islands: molecular phylogenetic approaches to understanding pattern and process. *Molecular Ecology* 11: 951–966.
2. Arnedo MA, Oromí P, Ribera C (2001) Radiation of the spider genus *Dysdera* (Araneae, Dysderidae) in the Canary Islands: Cladistic assessment based on multiple data sets. *Cladistics* 17: 313–353.
3. Bidegaray-Batista L, Macias-Hernandez N, Oromi P, Arnedo MA (2007) Living on the edge: demographic and phylogeographical patterns in the woodlouse-hunter spider *Dysdera lancerotensis* Simon, 1907 on the eastern volcanic ridge of the Canary Islands. *Molecular Ecology* 16: 3198–3214.
4. Macías-Hernández N, Oromí P, Arnedo MA (2008) Patterns of diversification on old volcanic islands as revealed by the woodlouse-hunter spider genus *Dysdera* (Araneae, Dysderidae) in the eastern Canary Islands. *Biological Journal of the Linnean Society* 94: 589–615.
5. Macías-Hernández N, Bidegaray-Batista L, Emerson BC, Oromí P, Arnedo M (2013) The Imprint of Geologic History on Within-Island Diversification of Woodlouse-Hunter Spiders (Araneae, Dysderidae) in the Canary Islands. *Journal of Heredity* 104: 341–356.
6. Macías-Hernández N, Bidegaray-Batista L, Oromí P, Arnedo MA (2013) The odd couple: contrasting phylogeographic patterns in two sympatric sibling species of woodlouse-hunter spiders in the Canary Islands. *Journal of Zoological Systematics and Evolutionary Research* 51: 29–37.

7. **Bloor P, Kemp SJ, Brown RP** (2008) Recent volcanism and mitochondrial DNA structuring in the lizard *Gallotia atlantica* from the island of Lanzarote. *Molecular Ecology* 17: 854–866.
8. **Vandergast AG, Gillespie RG, Roderick GK** (2004) Influence of volcanic activity on the population genetic structure of Hawaiian *Tetragnatha* spiders: fragmentation, rapid population growth and the potential for accelerated evolution. *Mol Ecol* 13: 1729–1743.
9. **Vandergast AG, Bohonak AJ, Weissman DB, Fisher RN** (2007) Understanding the genetic effects of recent habitat fragmentation in the context of evolutionary history: phylogeography and landscape genetics of a southern California endemic Jerusalem cricket (Orthoptera: Stenopelmatus). *Mol Ecol* 16: 977–992.
10. **Juan C, Emerson BC, Oromí P, Hewitt GM** (2000) Colonization and diversification: Towards a phylogeographic synthesis for the Canary Islands. *Trends in Ecology & Evolution* 15: 104–109.
11. **Carranza S, Arnold EN, Mateo JA, Geniez P** (2002) Relationships and evolution of the North African geckos, *Geckonia* and *Tarentola* (Reptilia: Gekkonidae), based on mitochondrial and nuclear DNA sequences. *Mol Phylogenet Evol* 23: 244–256.
12. **Emerson BC, Oromí P, Hewitt GM** (2000) Interpreting colonization of the *Calathus* (Coleoptera: Carabidae) on the Canary Islands and Madeira through the application of the parametric bootstrap. *Evolution* 54: 2081–2090.
13. **Nogales M, López M, Jiménez-Asensio J, Larruga JM, Hernández M, et al.** (1998) Evolution and biogeography of the genus *Tarentola* (Sauria: Gekkonidae) in the Canary Islands, inferred from mitochondrial DNA sequences. *Journal Of Evolutionary Biology* 11: 481–494.
14. **Stüben PE, Astrin JJ** (2010) Molecular phylogeny in endemic weevils: revision of the genera of Macaronesian Cryptorhynchinae (Coleoptera: Curculionidae). *Zoological Journal of the Linnean Society* 160: 40–87.
15. **Carracedo JC, Day S, Guillou H, Badiola ER, Canas JA, et al.** (1998) Hotspot volcanism close to a passive continental margin: The Canary Islands. *Geological Magazine* 135: 591–604.
16. **Ibáñez JM, De Angelis S, Díaz-Moreno A, Hernández P, Alguacil G, et al.** (2012) Insights into the 2011–2012 submarine eruption off the coast of El Hierro (Canary Islands, Spain) from statistical analyses of earthquake activity. *Geophysical Journal International* 191: 659–670.
17. **Carracedo JC, Torrado FP, González AR, Soler V, Turiel JLF, et al.** (2012) The 2011 submarine volcanic eruption in El Hierro (Canary Islands). *Geology Today* 28: 53–58.
18. **Carracedo JC, Singer B, Jicha B, Guillou H, Rodríguez-Badiola E, et al.** (2003) La erupción y el tubo volcánico del volcán Corona (Lanzarote, Islas Canarias). *Estudios Geológicos* 59: 277–302.
19. **Carracedo J, Rodríguez-Badiola E** (1993) Evolución geológica y magmática de la isla de Lanzarote (Islas Canarias). *Revista de la Academia Canaria de Ciencias* v: 25–58.
20. **Hedin M, Bond JE** (2006) Molecular phylogenetics of the spider infraorder Mygalomorphae using nuclear rRNA genes (18S and 28S): Conflict and agreement with the current system of classification. *Molecular Phylogenetics and Evolution* 41: 454–471.
21. **Platnick NI** (2014) *The World Spider Catalog*. v. 14.5. ed: American Museum of Natural History. Available: <http://research.amnh.org/entomology/spiders/catalog/index.html>. Accessed 2014 Mar 20.
22. **Raven RJ** (1985) The spider infraorder Mygalomorphae (Araneae): cladistics and systematics. *Bull Amer Mus Nat Hist* 182: 1–180.
23. **Bond JE, Hedin MC, Ramirez MG, Opell BD** (2001) Deep molecular divergence in the absence of morphological and ecological change in the Californian coastal dune endemic trapdoor spider *Aptostichus simus*. *Molecular Ecology* 10: 899–910.
24. **Bond JE, Stockman AK** (2008) An integrative method for delimiting cohesion species: Finding the population-species interface in a group of Californian trapdoor spiders with extreme genetic divergence and geographic structuring. *Systematic Biology* 57: 628–646.
25. **Stockman A, Bond JE** (2007) Delimiting cohesion species: extreme population structuring and the role of ecological interchangeability. *Molecular Ecology* 16: 3374–3392.
26. **Satler JD, Carstens BC, Hedin M** (2013) Multilocus Species Delimitation in a Complex of Morphologically Conserved Trapdoor Spiders (Mygalomorphae, Antrodiaetidae, *Aliatypus*). *Systematic Biology* 62: 805–823.

27. **Hendrixson BE, DeRussy BM, Hamilton CA, Bond JE** (2013) An exploration of species boundaries in turret-building tarantulas of the Mojave Desert (Araneae, Mygalomorphae, Theraphosidae, *Aphonopelma*). *Mol Phylogenet Evol* 66: 327–340.
28. **Coyle FA** (1985) Balloning behavior of *Ummidia* spiderlings (Araneae, Ctenizidae). *Journal of Arachnology* 13: 137–138.
29. **Eberhard WG** (2006) Dispersal by *Ummidia* spiderlings (Araneae, Ctenizidae): Ancient roots of aerial webs and orientation? *Journal of Arachnology* 34: 254–257.
30. **Coyle EA, Greenstone MH, Hultsch AL, Morgan CE** (1985) Ballooning mygalomorphs: Estimates of the masses of *Sphodros* and *Ummidia* ballooners (Araneae: Atypidae, Ctenizidae). *Journal of Arachnology* 13: 291–296.
31. **Raven RJ** (1980) The evolution and biogeography of the mygalomorph spider family Hexathelidae (Araneae, Chelicerata). *Journal of Arachnology* 8: 251–266.
32. **Ayoub NA, Garb JE, Hedin M, Hayashi CY** (2007) Utility of the nuclear protein-coding gene, elongation factor-1 gamma (EF-1g), for spider systematics, emphasizing family level relationships of tarantulas and their kin (Araneae: Mygalomorphae). *Molecular Phylogenetics and Evolution* 42: 394–409.
33. **Bond JE, Hendrixson BE, Hamilton CA, Hedin M** (2012) A Reconsideration of the Classification of the Spider Infraorder Mygalomorphae (Arachnida: Araneae) Based on Three Nuclear Genes and Morphology. *PLoS ONE* 7: e38753.
34. **Wunderlich J** (1992) Die Spinnen-Fauna der Makaronesischen Inseln: Taxonomie, Ökologie, Biogeographie und Evolution. *Beitr Araneol*: 1–619.
35. **Wunderlich J** (1995) Zu Ökologie, Biogeographie, Evolution und Taxonomie einiger Spinnen der Makaronesischen Inseln (Arachnida: Araneae). *Beitr Araneol*: 385–439.
36. **Satler JD, Starrett J, Hayashi CY, Hedin M** (2011) Inferring Species Trees from Gene Trees in a Radiation of California Trapdoor Spiders (Araneae, Antrodiaetidae, *Aliatypus*). *PLoS ONE* 6: e25355.
37. **Folmer O, Black M, Hoeh W, Lutz R, Vrijenhoek R** (1994) DNA primers for amplification of mitochondrial cytochrome c oxidase subunit I from diverse metazoan invertebrates. *Molecular Marine Biology and Biotechnology* 3: 294–299.
38. **Simon C, Frati F, Beckenbach A, Crespi B, Liu B, et al.** (1994) Evolution, weighting and phylogenetic utility of mitochondrial gene sequences and a compilation of conserved polymerase chain reaction primers. *Ann Entomol Soc Am* 87: 651–701.
39. **Hedin MC** (1997) Molecular phylogenetics at the population/species interface in cave spiders of the Southern Appalachians (Araneae: Nesticidae: *Nesticus*). *Molecular Biology and Evolution* 14: 309–324.
40. **Giribet G, Rambla M, Carranza S, Bagnà J, Riutort M, et al.** (1999) Phylogeny of the arachnid order Opiliones (Arthropoda) inferred from a combined approach of complete 18S and partial 28S ribosomal DNA sequences and morphology. *Molecular Phylogenetics and Evolution* 11: 296–307.
41. **Hedin MC, Maddison WP** (2001) A combined molecular approach to phylogeny of the jumping spider subfamily Dendryphantinae (Araneae: Salticidae). *Molecular Phylogenetics and Evolution* 18: 386–403.
42. **Colgan DJ, McLauchlan A, Wilson GDF, Livingston SP, Edgecombe GD, et al.** (1998) Histone H3 and U2 snRNA DNA sequences and arthropod molecular evolution. *Australian Journal of Zoology* 46: 419–437.
43. **Drummond A, Ashton B, Cheung M, Heled J, Kearse M, et al.** (2010) Geneious v.5.3. Geneious Home Page. Available: <http://www.geneious.com>. Accessed 2011 Aug. 3.
44. **Katoh K, Toh H** (2008) Recent developments in the MAFFT multiple sequence alignment program. *Briefings in Bioinformatics* 9: 286–298.
45. **Abascal F, Zardoya R, Telford MJ** (2010) TranslatorX: multiple alignment of nucleotide sequences guided by amino acid translations. *Nucleic Acids Res* 38: W7–13.
46. **Stephens M, Donnelly P** (2003) A Comparison of Bayesian Methods for Haplotype Reconstruction from Population Genotype Data. *American Journal of Human Genetics* 73: 1162–1169.
47. **Stephens M, Smith NJ, Donnelly P** (2001) A New Statistical Method for Haplotype Reconstruction from Population Data. *American Journal of Human Genetics* 68: 978–989.

48. **Librado P, Rozas J** (2009) DnaSP v5: a software for comprehensive analysis of DNA polymorphism data. *Bioinformatics* 25: 1451–1452.
49. **McGuire G, Wright F, Prentice MJ** (2000) A Bayesian model for detecting past recombination events in DNA multiple alignments. *J Comput Biol* 7: 159–170.
50. **Milne I, Lindner D, Bayer M, Husmeier D, McGuire G, et al.** (2009) TOPALi v2: a rich graphical interface for evolutionary analyses of multiple alignments on HPC clusters and multi-core desktops. *Bioinformatics* 25: 126–127.
51. **Kekkonen M, Hebert PD** (2014) DNA barcode-based delineation of putative species: efficient start for taxonomic workflows. *Mol Ecol Resour.*
52. **Talavera G, Dinca V, Vila R** (2013) Factors affecting species delimitations with the GMYC model: insights from a butterfly survey. *Methods in Ecology and Evolution* 4: 1101–1110.
53. **Irwin DE** (2002) Phylogeographic breaks without geographic barriers to gene flow. *Evolution Int J Org Evolution* 56: 2383–2394.
54. **Kuo C, Avise J** (2005) Phylogeographic breaks in low-dispersal species: the emergence of concordance across gene trees. *Genetica* 124: 179–186.
55. **Camargo A, Morando M, Avila LJ, Sites JW** (2012) Species Delimitation with ABC and other Coalescent-Based Methods: A Test of Accuracy with Simulations and an empirical Example with Lizards of the *Liolaemus Darwinii* Complex (Squamata: Liolaemidae). *Evolution* 66: 2834–2849.
56. **Pons J** (2006) DNA-based identification of preys from non-destructive, total DNA extractions of predators using arthropod universal primers. *Molecular Ecology Notes* 6: 623–626.
57. **Monaghan MT, Wild R, Elliot M, Fujisawa T, Balke M, et al.** (2009) Accelerated Species Inventory on Madagascar Using Coalescent-Based Models of Species Delineation. *Systematic Biology* 58: 298–311.
58. **Rambaut A, Drummond AJ** (2009) TRACER v.1.5. 1.4 ed: Available: <http://tree.bio.ed.ac.uk/software/tracer/>. Accessed 2009 Dec 1.
59. **Ezard T, Fujisawa T, Barraclough TG** (2009) splits: SPecies' Limits by Threshold Statistics. Rpackage version 1.0-11/r29. R-Forge website. Available: <http://R-Forge.R-project.org/projects/splits/>. Accessed 2012 Feb 10.
60. **Simmons MP, Ochoterena H** (2000) Gaps as characters in sequence-based phylogenetic analyses. *Systematic Biology* 49: 369–381.
61. **Borchsenius F** (2009) FastGap 1.2.
62. **Lanfear R, Calcott B, Ho SYW, Guindon S** (2012) PartitionFinder: Combined Selection of Partitioning Schemes and Substitution Models for Phylogenetic Analyses. *Molecular Biology and Evolution* 29: 1695–1701.
63. **Ronquist F, Huelsenbeck J** (2003) MrBayes 3: Bayesian phylogenetic inference under mixed models. *Bioinformatics* 19: 1572–1574.
64. **Miller MA, Pfeiffer W, Schwartz T** (2010) Creating the CIPRES Science Gateway for inference of large phylogenetic trees. *Proceedings of the Gateway Computing Environments Workshop (GCE)*. New Orleans, LA. pp. 1–8.
65. **Stamatakis A** (2006) RAxML-VI-HPC: maximum likelihood-based phylogenetic analyses with thousands of taxa and mixed models. *Bioinformatics* 22: 2688–2690.
66. **Rambaut A** (2009) FigTree v. 1.3.1
67. **Drummond AJ, Suchard MA, Xie D, Rambaut A** (2012) Bayesian phylogenetics with BEAUti and the BEAST 1.7. *Molecular Biology and Evolution*.
68. **Baele G, Lemey P, Bedford T, Rambaut A, Suchard MA, et al.** (2012) Improving the accuracy of demographic and molecular clock model comparison while accommodating phylogenetic uncertainty. *Molecular Biology and Evolution*.
69. **Bidegaray-Batista L, Arnedo M** (2011) Gone with the plate: the opening of the Western Mediterranean basin drove the diversification of ground-dweller spiders. *BMC Evolutionary Biology* 11: 317.
70. **Heled J, Drummond AJ** (2010) Bayesian inference of species trees from multilocus data. *Molecular Biology and Evolution* 27: 570–580.

71. **Opatova V, Bond JE, Arnedo MA** (2013) Ancient origins of the Mediterranean trap-door spiders of the family Ctenizidae (Araneae, Mygalomorphae). *Mol Phylogenet Evol* 69: 1135–1145.
72. **Opatova V, Arnedo M** (2014) From Gondwana to Europe: inferring the origins of Mediterranean *Macrothele* spiders (Araneae: Hexathelidae) and the limits of the family Hexathelidae. *Invertebrate Systematics* 28: 361–374.
73. **Carracedo JC, Day S** (2002) Canary Islands. Harpenden, Hertfordshire, UK: Terra Publishing. 294 p.
74. **Lemey P, Rambaut A, Drummond AJ, Suchard MA** (2009) Bayesian Phylogeography Finds Its Roots. *PLoS Comput Biol* 5: e1000520.
75. **Ancochea E, Brändle JL, Cubas CR, Hernán F, Huertas MJ** (1996) Volcanic complexes in the eastern ridge of the Canary Islands: the Miocene activity of the island of Fuerteventura. *Journal of Volcanology and Geothermal Research* 70: 183–204.
76. **Rannala B, Yang Z** (2013) Improved Reversible Jump Algorithms for Bayesian Species Delimitation. *Genetics* 194: 245–253.
77. **Yang Z, Rannala B** (2010) Bayesian species delimitation using multilocus sequence data. *Proceedings of the National Academy of Sciences* 107: 9264–9269.
78. **Leaché AD, Fujita MK** (2010) Bayesian species delimitation in West African forest geckos (*Hemidactylus fasciatus*). *Proceedings of the Royal Society B: Biological Sciences* 277: 3071–3077.
79. **Teacher AGF, Griffiths DJ** (2011) HapStar: automated haplotype network layout and visualization. *Molecular Ecology Resources* 11: 151–153.
80. **Excoffier L, Laval G, Schneider S** (2005) ARLEQUIN, Version 3.0: an Integrated Software Package for Population Genetics Data Analysis. *Evolutionary Bioinformatics Online* 1: 47–50.
81. **Jensen JL, Bohonak AJ, Kelley ST** (2005) Isolation by distance, web service. *BMC Genetics* 6: 13.
82. **Ho SYW, Phillips MJ, Cooper A, Drummond AJ** (2005) Time Dependency of Molecular Rate Estimates and Systematic Overestimation of Recent Divergence Times. *Molecular Biology and Evolution* 22: 1561–1568.
83. **Marino IA, Pujolar JM, Zane L** (2011) Reconciling deep calibration and demographic history: Bayesian inference of post glacial colonization patterns in *Carcinus aestuarii* (Nardo, 1847) and *C. maenas* (Linnaeus, 1758). *PLoS ONE* 6: e28567.
84. **Emerson BC** (2007) Alarm Bells for the Molecular Clock? No Support for Ho et al.'s Model of Time-Dependent Molecular Rate Estimates. *Systematic Biology* 56: 337–345.
85. **Hedin M, Starrett J, Hayashi C** (2013) Crossing the uncrossable: novel trans-valley biogeographic patterns revealed in the genetic history of low-dispersal mygalomorph spiders (Antrodiaetidae, *Antrodiaetus*) from California. *Mol Ecol* 22: 508–526.
86. **Raven RJ** (1988) A revision of the mygalomorph spider genus *Idioctis* (Araneae, Barychelidae). *American Museum novitates*. *American Museum Novitates* 2929: 1–47.
87. **Churchill TB, Raven RJ** (1992) Systematics of the intertidal trapdoor spider genus *Idioctis* (Mygalomorphae: Barychelidae) in the western Pacific with a new genus from the northeast. *Memoirs of The Queensland Museum* 32: 9–30.
88. **Raven RJ** (1994) Mygalomorph spiders of the Barychelidae in Australia and the western Pacific. *Memoirs of The Queensland Museum* 35: 291–706.
89. **Griffin DL** (2002) Aridity and humidity: two aspects of the late Miocene climate of North Africa and the Mediterranean. *Palaeogeography, Palaeoclimatology, Palaeoecology* 182: 65–91.
90. **Köhler C, Heslop D, Krijgsman W, Dekkers M** (2010) Late Miocene paleoenvironmental changes in North Africa and the Mediterranean recorded by geochemical proxies (Monte Gibliscemi section, Sicily). *Palaeogeography, Palaeoclimatology, Palaeoecology* 285: 66–73.
91. **Haq BU, Hardenbol J, Vail PR** (1987) Chronology of fluctuating sea level since the Triassic. *Science* 235: 1156–1167.
92. **Pagès M, Chevret P, Gros-Balthazard M, Hughes S, Alcover JA, et al.** (2012) Paleogenetic Analyses Reveal Unsuspected Phylogenetic Affinities between Mice and the Extinct *Malpaisomys insularis*, an Endemic Rodent of the Canaries. *PLoS ONE* 7: e31123.

93. **Edwards SV, Beerli P** (2000) Perspective: gene divergence, population divergence, and the variance in coalescence time in phylogeographic studies. *Evolution* 54: 1839–1854.
94. **Arbogast BS, Edwards SV, Wakeley J, Beerli P, Slowinski JB** (2002) Estimating divergence times from molecular data on phylogenetic and population genetic timescales. *Annual Review of Ecology and Systematics* 33: 707–740.
95. **McCormack JE, Heled J, Delaney KS, Peterson AT, Knowles LL** (2011) Calibrating divergence times on species trees versus gene trees: implications for speciation history of *Aphelocoma jays*. *Evolution; international journal of organic evolution* 65: 184–202.
96. **Kubatko LS, Gibbs HL, Bloomquist EW** (2011) Inferring Species-Level Phylogenies and Taxonomic Distinctiveness Using Multilocus Data in *Sistrurus* Rattlesnakes. *Systematic Biology* 60: 393–409.
97. **Sánchez-Gracia A, Castresana J** (2012) Impact of Deep Coalescence on the Reliability of Species Tree Inference from Different Types of DNA Markers in Mammals. *PLoS ONE* 7: e30239.
98. **Jennings WB, Edwards SV** (2005) Speciation history of Australian grass finches (*Poephila*) inferred from thirty gene trees. *Evolution* 59: 2033–2047.
99. **Santos Guerra A** (2002) Flora Vascular Nativa. In Fernández-Palacios JM, Martín-Esquivel J (editors). *Naturaleza de las Islas Canarias Ecología y Conservación*. San Cristobal de La Laguna: Turquesa. pp. 185–192.
100. **Bidegaray-Batista L, Macías-Hernández N, Oromí P, Arnedo MA** (2007) Living on the edge: demographic and phylogeographical patterns in the woodlouse-hunter spider *Dysdera lancerotensis* Simon, 1907 on the eastern volcanic ridge of the Canary Islands. *Molecular Ecology* 16: 3198–3214.
101. **Brown RP, Yang Z** (2010) Bayesian Dating of Shallow Phylogenies with a Relaxed Clock. *Syst Biol* 59: 119–131.
102. **Meco J** (2008) *Historia geológica del clima en Canarias*. Las Palmas de Gran Canaria: Laboratorio de Paleontología, Departamento de Biología, Universidad de Las Palmas de Gran Canaria (ULPGC).
103. **Dimitrov D, Arnedo MA, Ribera C** (2008) Colonization and diversification of the spider genus *Pholcus* Walckenaer, 1805 (Araneae, Pholcidae) in the Macaronesian archipelagos: Evidence for long-term occupancy yet rapid recent speciation. *Molecular Phylogenetics and Evolution* 48: 596–614.
104. **Macias-Hernandez N, Oromi P, Arnedo MA** (2010) Integrative taxonomy uncovers hidden species diversity in woodlouse hunter spiders (Araneae, Dysderidae) endemic to the Macaronesian archipelagos. *Systematics and Biodiversity* 8: 531–553.
105. **Cox SC, Carranza S, Brown RP** (2010) Divergence times and colonization of the Canary Islands by *Gallotia* lizards. *Molecular Phylogenetics and Evolution* 56: 747–757.
106. **Arnedo MA, Ferrandez MA** (2007) Mitochondrial markers reveal deep population subdivision in the European protected spider *Macrothele calpeiana* (Walckenaer, 1805) (Araneae, Hexathelidae). *Conservation Genetics* 8: 1147–1162.
107. **Starrett J, Hedin M** (2007) Multilocus genealogies reveal multiple cryptic species and biogeographical complexity in the California turret spider *Antrodiaetus riversi* (Mygalomorphae, Antrodiaetidae). *Molecular Ecology* 16: 583–604.
108. **Hendrixson BE, Bond JE** (2007) Molecular phylogeny and biogeography of an ancient Holarctic lineage of mygalomorph spiders (Araneae: Antrodiaetidae: *Antrodiaetus*). *Molecular Phylogenetics and Evolution* 42: 738–755.
109. **Decae AE** (1996) Systematics of the trapdoor spider genus *Cyrtocarenum* Ausserer, 1871 (Araneae, Ctenizidae). *Bulletin of British arachnological Society* 10: 161–170.
110. **Bond JE, Beamer DA, Lamb T, Hedin M** (2006) Combining genetic and geospatial analyses to infer population extinction in mygalomorph spiders endemic to the Los Angeles region. *Animal Conservation* 9: 145–157.
111. **Hamilton CA, Formanowicz DR, Bond JE** (2011) Species Delimitation and Phylogeography of *Aphonopelma hentzi* (Araneae, Mygalomorphae, Theraphosidae): Cryptic Diversity in North American Tarantulas. *PLoS ONE* 6: e26207.
112. **Padial J, Miralles A, De la Riva I, Vences M** (2010) The integrative future of taxonomy. *Frontiers in Zoology* 7: 16.

113. Fujita MK, Leachè AD, Burbrink FT, McGuire JA, Moritz C (2012) Coalescent-based species delimitation in an integrative taxonomy. Trends in ecology & evolution (Personal edition).
114. Carstens BC, Pelletier TA, Reid NM, Satler JD (2013) How to fail at species delimitation. Molecular Ecology 22: 4369–4383
115. Burbrink FT, Pyron RA (2011) The impact of gene-tree/species-tree discordance on diversification-rate estimation. Evolution 65: 1851–1861.
116. Brown RM, Siler CD, Lee Grismer L, Das I, McGuire JA (2012) Phylogeny and cryptic diversification in Southeast Asian flying geckos. Molecular Phylogenetics and Evolution 65: 351–361.
117. Pepper M, Doughty P, Fujita MK, Moritz C, Keogh JS (2013) Speciation on the Rocks: Integrated Systematics of the *Heteronotia spelea* Species Complex (Gekkota; Reptilia) from Western and Central Australia. PLoS ONE 8: e78110.
118. Sstrom M, Donnellan SC, Hutchinson MN (2013) Delimiting species in recent radiations with low levels of morphological divergence: a case study in Australian *Gehyra* geckos. Mol Phylogenet Evol 68: 135–143.
119. Páez-Moscoso DJ, Guayasamin JM (2012) Species limits in the Andean toad genus *Osomophryne* (Bufonidae). Molecular Phylogenetics and Evolution 65: 805–822.
120. Zhang C, Zhang D-X, Zhu T, Yang Z (2011) Evaluation of a Bayesian Coalescent Method of Species Delimitation. Systematic Biology 60: 747–761.
121. Arnedo MA, Oromí P, Ribera C (2000) Systematics of the genus *Dysdera* (Araneae, Dysderidae) in the Eastern Canaries. Journal of Arachnology 28: 261–292.
122. Planas E, Fernández-Montraveta C, Ribera C (2013) Molecular systematics of the wolf spider genus *Lycosa* (Araneae: Lycosidae) in the Western Mediterranean Basin. Molecular Phylogenetics and Evolution 67: 414–428.
123. Pinho C, Harris DJ, Ferrand N (2007) Contrasting patterns of population subdivision and historical demography in three western Mediterranean lizard species inferred from mitochondrial DNA variation. Molecular Ecology 16: 1191–1205.
124. Santos X, Rato C, Carranza S, Carretero MA, Pleguezuelos JM (2012) Complex phylogeography in the Southern Smooth Snake (*Coronella girondica*) supported by mtDNA sequences. Journal of Zoological Systematics and Evolutionary Research 50: 210–219.
125. Simon E (1903) Histoire naturelle des araignées. Paris: Roret. 669–1080. p.
126. Simon E (1909) Etude sur les Arachnides recueillis au Maroc par M. Martinez de la Escalera en 1907. Memorias de la Real Sociedad Española de Historia Natural 6: 1–43.
127. Andrus N, Trusty J, Santos-Guerra A, Jansen Robert K, Francisco-Ortega J (2004) Using Molecular Phylogenies to Test Phylogeographical Links between East/South Africa-Southern Arabia and the Macaronesian Islands: A Review, and the Case of *Vierea* and *Pulicaria* Section *Vieraeopsis* (Asteraceae). Taxon 333–346.
128. Sanmartin I, Anderson CL, Alarcon M, Ronquist F, Aldasoro JJ (2010) Bayesian island biogeography in a continental setting: the Rand Flora case. Biology Letters: rsbl20100095.
129. Thiv M, Thulin M, Hjertson M, Kropf M, Linder HP (2010) Evidence for a vicariant origin of Macaronesian Eritreo/Arabian disjunctions in *Campylanthus* Roth (Plantaginaceae). Molecular Phylogenetics and Evolution 54: 607–616.
130. Carine MA, Russell SJ, Santos-Guerra A, Francisco-Ortega J (2004) Relationships of the Macaronesian and Mediterranean floras: molecular evidence for multiple colonizations into Macaronesia and back-colonization of the continent in *Convolvulus* (Convolvulaceae). American Journal of Botany 91: 1070–1085.
131. Greve C, Hutterer R, Groh K, Haase M, Misof B (2010) Evolutionary diversification of the genus *Theba* (Gastropoda: Helicidae) in space and time: A land snail conquering islands and continents. Molecular Phylogenetics and Evolution In Press, Corrected Proof.
132. Päckert M, Martens J, Hering J, Kvist L, Illera JC (2013) Return flight to the Canary Islands: The key role of peripheral populations of Afrocanarian blue tits (Aves: *Cyanistes teneriffae*) in multi-gene reconstructions of colonization pathways. Molecular Phylogenetics and Evolution 67: 458–467.