



Archived at the Flinders Academic Commons:

<http://dspace.flinders.edu.au/dspace/>

This is the publisher's version of a report published on the website of the *International Baccalaureate Organisation*.

The original publication is available by at:

<http://www.ibo.org/en/about-the-ib/research/programme-impact-research/myp-studies/>

Please cite this article as:

Skrzypiec, G, Askill-Williams, H, Slee, P and Rudzinski, A. 2014. International Baccalaureate Middle Years Programme: Student social- emotional well-being and school success practices. Bethesda, MD, USA. International Baccalaureate Organization.

Copyright 2014 International Baccalaureate Organisation. Published version of the paper reproduced here with permission from the publisher.

# **IB MIDDLE YEARS PROGRAMME (MYP): STUDENT SOCIAL-EMOTIONAL WELL- BEING AND SCHOOL SUCCESS PRACTICES**

**April 2014**

Grace Skrzypiec

Helen Askeil-Williams

Phillip Slee

Adrian Rudzinski

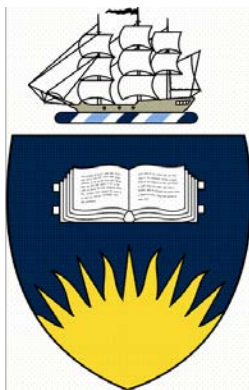

Flinders University

Centre for Student Well-being and Prevention of Violence

Flinders Educational Futures Research Institute

School of Education

Adelaide, South Australia

## Contents

List of Figures .....	6
List of Tables .....	8
Abbreviations .....	9
<b>EXECUTIVE SUMMARY .....</b>	<b>11</b>
Background to the Study .....	12
The Research Questions .....	12
Methodology .....	12
Summary of Findings .....	13
IB MYP Student Well-being .....	13
IB MYP Students Flourishing .....	13
IB MYP Students Languishing .....	14
IB MYP Students with a Positive Outlook and a Positive Emotional State .....	14
IB MYP Student Profile .....	15
IB MYP Student Satisfaction with School .....	15
School Success Practices .....	16
Mental Ill-health .....	16
Gender Differences .....	17
Differences Between Year Levels .....	17
Females in the Upper Years of IB MYP .....	18
Factors Associated with Well-being .....	18
Study Limitations .....	19
Summary and Conclusions .....	19
<b>INTRODUCTION .....</b>	<b>21</b>
Mental Health and Well-being .....	22
Measuring Well-being .....	23
Well-being in the International Baccalaureate (IB) Context .....	25
The South Australian Context .....	26
DECD Learner Well-being Framework .....	26
Ethics Approvals .....	27
Structure of this Report .....	27
<b>PROCEDURES .....</b>	<b>29</b>
Data Collection .....	29
Method .....	29
Students as Informants .....	29
Well-being Questionnaire (WBQ) .....	30
Pilot Study of the WBQ .....	31
Final WBQ .....	31
Interviews and Focus Groups .....	34
Staff .....	35
Students .....	35
<b>Sampling .....</b>	<b>36</b>
School Sample .....	37
Response Rates .....	38
Student Focus Groups .....	39
Staff Interviews .....	39
Survey Sample .....	39
Gender .....	39
Year Level .....	39
Age .....	40
Socio-Economic (SES) Background .....	41
Analysis of Data .....	42
<b>PSYCHOLOGICAL FLOURISHING .....</b>	<b>47</b>
Psychological Flourishing: Measurement .....	47

Psychological Flourishing: FloS Total Scores .....	48
Psychological Flourishing (FloS) by Gender and Year Level.....	48
Psychological Flourishing (FloS) by Socio-Economic (SES) Background .....	51
The Flourishing Scale Model .....	51
Comparison with Other Students .....	52
<b>Discussion .....</b>	<b>53</b>
Subsequent Analyses.....	54
<b>MENTAL HEALTH CONTINUUM .....</b>	<b>55</b>
Mental Health Continuum: Well-being Measure.....	56
The Mental Health Continuum (MentHC) Model.....	56
MentHC: Well-being Composite Measure .....	57
MentHC: Flourishing by Gender and Year Level.....	58
MentHC: Languishing by Gender and Year Level.....	59
MentHC: Moderate Mental Health by Gender and Year Level .....	60
<b>School Well-being Programmes and Approaches.....</b>	<b>62</b>
<b>Discussion .....</b>	<b>65</b>
<b>POSITIVE OUTLOOK AND POSITIVE EMOTIONAL STATE.....</b>	<b>67</b>
<b>Stirling Children’s Well-being (StirCWB) Scale .....</b>	<b>67</b>
StirCWB: Total Scores.....	68
StirCWB by Gender.....	68
StirCWB by Gender and Year Level.....	69
Stirling Children’s Well-being (StirCWB) Model.....	69
Positive Outlook.....	70
Positive Outlook by Gender and Year Level.....	71
Positive Emotional State.....	71
Positive Emotional State by Gender and Year Level .....	73
<b>Discussion .....</b>	<b>73</b>
<b>STUDENT WELL-BEING AND THE IB LEARNER PROFILE.....</b>	<b>75</b>
<b>Caring .....</b>	<b>75</b>
<b>Empathy .....</b>	<b>76</b>
Empathy.....	78
Cognitive Empathy .....	78
Affective Empathy .....	79
Empathy and Well-being .....	80
Developing Student Empathy.....	82
<b>Balance .....</b>	<b>83</b>
<b>Global Self-concept.....</b>	<b>84</b>
Global Self-concept by Gender and Year Level.....	86
Global Self-concept and Well-being.....	86
Building Students’ Self-concept.....	88
<b>Reflection .....</b>	<b>89</b>
Self-Reflection.....	89
Self-Reflection by Gender and Year Level.....	90
Self-Reflection and Well-being .....	90
Students’ Views about Self-Reflection .....	93
<b>Resilience.....</b>	<b>95</b>
Resilience Scores .....	95
Resilience by Gender and Year Level.....	96
Resilience and Well-being.....	96
<b>Relationships .....</b>	<b>99</b>
Relationship Model.....	99
Relationships by Gender and Year Level.....	101
Relationships and Well-being.....	101
Students’ Views about Relationships at School.....	103
Peer Relationships.....	103
Student Teacher Relationships .....	104

<b>Discussion .....</b>	<b>105</b>
Empathy.....	105
Global Self-concept .....	106
Reflection.....	106
Resilience .....	107
Relationships.....	107
<b>SCHOOL SATISFACTION.....</b>	<b>109</b>
<b>Contentment at School.....</b>	<b>110</b>
Comparison with Other Schools in South Australia.....	112
<b>School Satisfaction .....</b>	<b>113</b>
Components of School Satisfaction.....	115
Enjoy School.....	115
Enjoy Learning.....	116
Feel Supported.....	117
School Fellowship.....	118
School Satisfaction and Well-being.....	119
<b>Bullying.....</b>	<b>121</b>
Bullying by Gender and Year Level.....	121
Empathy and Bullying.....	123
Students' Comments and Drawings about Satisfaction with School.....	124
<b>Discussion .....</b>	<b>125</b>
<b>SCHOOL SUCCESS PRACTICES.....</b>	<b>127</b>
<b>The Concept of Success .....</b>	<b>128</b>
Students' Views of Success.....	128
Staff's Views of Success .....	129
<b>School Success Practices According to Students .....</b>	<b>130</b>
Positive Comments.....	131
Negative Comments .....	132
Mixed Comments.....	133
Focus Group Findings .....	134
<b>School Success Practices According to Staff.....</b>	<b>135</b>
Enablers of Success .....	135
Barriers to Success .....	139
<b>Discussion .....</b>	<b>141</b>
<b>MENTAL HEALTH STRENGTHS AND DIFFICULTIES.....</b>	<b>143</b>
<b>The Strengths and Difficulties Questionnaire (SDQ).....</b>	<b>143</b>
<b>Mental Ill-health .....</b>	<b>144</b>
Females in the Upper Years of MYP .....	148
<b>Discussion .....</b>	<b>149</b>
<b>SUMMARY AND CONCLUSION.....</b>	<b>151</b>
<b>The Well-being of IB MYP Students .....</b>	<b>151</b>
IB MYP Students Flourishing.....	151
IB MYP Students Languishing .....	152
IB MYP Students with Moderate Mental Health .....	152
IB MYP Students with a Positive Outlook and a Positive Emotional State .....	153
<b>IB MYP Student Profile .....</b>	<b>153</b>
Cognitive Empathy.....	153
Affective Empathy.....	153
Global Self-concept .....	154
Self-Reflection.....	154
Resilience .....	154
Relationships.....	155
<b>IB MYP Student Satisfaction with School .....</b>	<b>155</b>
<b>School Success Practices.....</b>	<b>155</b>
<b>Mental Ill-health .....</b>	<b>156</b>
<b>Gender Differences .....</b>	<b>156</b>

<b>Differences Between Year Levels.....</b>	<b>156</b>
Females in the Upper Years of MYP .....	157
<b>Limitations.....</b>	<b>157</b>
<b>REFERENCES.....</b>	<b>159</b>
<b>APPENDICES.....</b>	<b>171</b>
<b>Appendix A.....</b>	<b>171</b>
Flourishing Scale .....	171
Mental Health Continuum.....	172
Stirling Children’s Well-being .....	173
Empathy.....	174
Global Self-concept .....	175
Self-Reflection.....	175
Resilience .....	176
Relationship.....	177
School Satisfaction .....	178
Bullying .....	179
Strengths and Difficulties Questionnaire.....	180
<b>Appendix B.....</b>	<b>181</b>
Flourishing Scale (FloS) .....	181
Mental Health Continuum (MentHC).....	183
Stirling Children’s Well-being Scale (StirCWB) .....	185
Cognitive and Affective Empathy.....	187
Global Self-Concept .....	188
Self-Reflection.....	189
Resilience .....	190
Relationships .....	191
School Satisfaction .....	192
Strengths and Difficulties Questionnaire.....	193

## List of Figures

Figure 1	DECD Learner Well-being Framework .....	26
Figure 2	Mixed method study design .....	30
Figure 3	Proportion of student participants from each school .....	37
Figure 4	Gender of study participants .....	39
Figure 5	Proportion of student participants in each year level.....	40
Figure 6	Mean age of study participants in each year level .....	41
Figure 7	Socio-economic background of study sample compared to the Australian population .....	42
Figure 8	Flourishing (FloS) scores of IB MYP student participants .....	48
Figure 9	Flourishing (FloS) scores of male and female IB MYP student participants.....	49
Figure 10	Distribution of flourishing (FloS) scores of males and females .....	49
Figure 11	Mean Flourishing (FloS) scores by age .....	50
Figure 12	Mean flourishing (FloS) scores by age and gender .....	50
Figure 13	Mean flourishing (FloS) scores by age and year level.....	50
Figure 14	Flourishing (FloS) scores by socio-economic (SES) background .....	51
Figure 15	IB MYP students' experience of well-being (MentHC composite measure).....	57
Figure 16	Male and female IB MYP students' experience of well-being (MentHC composite measure) .....	58
Figure 17	Proportion of males and females flourishing in each year level.....	59
Figure 18	Proportion of males and females languishing in each year level.....	60
Figure 19	Proportion of males and females with moderate mental health in each year level.....	60
Figure 20	Total StirC well-being scores of IB MYP Students .....	68
Figure 21	Total StirC well-being scores of male and female IB MYP students .....	69
Figure 22	Total StirC well-being scores of male and female IB MYP students by year level.....	69
Figure 23	IB MYP students' experience of positive outlook.....	70
Figure 24	Male and female IB MYP students' experience of positive outlook .....	71
Figure 25	Male and female IB MYP students' experience of positive outlook by year level.....	71
Figure 26	IB MYP students' experience of a positive emotional state .....	72
Figure 27	Male and female IB MYP students' experience of a positive emotional state.....	72
Figure 28	Male and female IB MYP students' experience of a positive emotional state by year level.....	73
Figure 29	Level of cognitive empathy of IB MYP students .....	78
Figure 31	Level of affective empathy of IB MYP students.....	79
Figure 30	Mean cognitive empathy scores of male and female IB MYP students by year level .....	79
Figure 32	Mean affective empathy scores of male and female IB MYP students by year level .....	80
Figure 33	Cognitive and affective empathy as predictors of well-being.....	82
Figure 34	Sense of a positive global self-concept of IB MYP students.....	85
Figure 35	Sense of a positive global self-concept of male and female IB MYP students.....	85
Figure 36	Mean global self-concept scores of male and female IB MYP students by year level .....	86
Figure 37	Global self-concept as a predictor of well-being .....	88
Figure 38	Engagement in self-reflection by IB MYP students.....	90
Figure 39	Mean self-reflection scores of male and female IB MYP students by year level.....	90
Figure 40	Self-Reflection as a predictor of well-being .....	92
Figure 41	Comment made by a female IB MYP student about reflection.....	94
Figure 42	Incidence of being resilient of IB MYP students.....	96
Figure 43	Mean resilience scores of male and female IB MYP students by year level.....	96
Figure 44	Resilience as a predictor of well-being.....	98
Figure 45	Relationship Scores of IB MYP Students.....	100
Figure 46	Mean relationship scores of male and female IB MYP students by year level .....	101
Figure 47	The Relationship factor as a predictor of well-being .....	103
Figure 48	Example of positive school relationships.....	104
Figure 49	Self-reported happiness at school of IB MYP students.....	110
Figure 50	Self-reported level of happiness at school of IB MYP students from different SES backgrounds.....	111
Figure 51	Self-reported level of happiness at school of students in low, middle and high SES .....	111
Figure 52	Happiness at school by age.....	112
Figure 53	Happiness at school by year level .....	112
Figure 54	Happiness at school of IB MYP students and other SA students aged 11-16 .....	112

Figure 55	Level of satisfaction with school of IB MYP students .....	114
Figure 56	Level of satisfaction with school of male and female IB MYP students .....	114
Figure 57	Extent of enjoying school of IB MYP students .....	115
Figure 58	Extent of enjoying school of male and female IB MYP students.....	115
Figure 59	Extent of learning enjoyment of IB MYP students.....	116
Figure 60	Extent of learning enjoyment of male and female IB MYP students .....	116
Figure 61	Extent of feeling supported at school of IB MYP students .....	117
Figure 62	Extent of feeling supported at school of male and female IB MYP students .....	117
Figure 63	Extent of school fellowship of IB MYP students .....	118
Figure 64	Extent of school fellowship of male and female IB MYP students .....	118
Figure 65	School satisfaction as a predictor of well-being .....	120
Figure 66	Self-reported levels of bullying of male and female IB MYP students .....	122
Figure 67	Self-reported levels of serious bullying of male and female IB MYP students .....	122
Figure 68	Incidence of self-reported bullying of IB MYP students by year level .....	123
Figure 69	Cognitive and affective empathy as predictors of bullying others and being bullied .....	124
Figure 70	Illustrative examples of being happy at school provided by IB MYP students.....	125
Figure 71	Word cloud of student responses about school.....	131
Figure 72	Examples of positive sentiments about school provided by IB MYP students .....	132
Figure 73	Examples of negative sentiments about school provided by IB MYP students .....	133
Figure 74	Examples of mixed sentiments about school provided by IB MYP students .....	134
Figure 75	Mean SDQ scores of female IB MYP students compared to the Australian normal range .....	147
Figure 76	Examples of responses provided by females in the upper years of MYP .....	148
Appendix B Figure 1	Flourish (FloS) latent variable .....	181
Appendix B Figure 2	Influence of covariates on flourishing (FloS) scores (MIMIC model) .....	182
Appendix B Figure 3	MentHC model.....	183
Appendix B Figure 4	Influence of covariates on well-being measured using the MentHC (MIMIC model) .....	184
Appendix B Figure 5	StirCWB model.....	185
Appendix B Figure 6	Influence of covariates on well-being measured using the StirCWB (MIMIC model).....	186
Appendix B Figure 7	Cognitive and Affective Empathy Model .....	187
Appendix B Figure 8	Global Self-concept latent variable .....	188
Appendix B Figure 9	Influence of covariates on global self-concept (MIMIC model) .....	188
Appendix B Figure 10	Self-reflection latent variable .....	189
Appendix B Figure 11	Resilience latent variable .....	190
Appendix B Figure 12	Relationships latent variable .....	191
Appendix B Figure 13	School satisfaction model .....	192
Appendix B Figure 14	SDQ Model .....	193
Appendix B Figure 15	Influence of covariates on Total SDQ (MIMIC model) .....	194



## List of Tables

Table 1	Summary of well-being findings.....	14
Table 2	Types of schools participating in the study.....	37
Table 3	Response rates from participating schools.....	38
Table 4	Number of male and female participants from each school.....	38
Table 5	Gender and year level of study participants.....	40
Table 6	Percentiles of IB MYP students and college students.....	53
Table 7	IB Learner Profile and social and emotional connections.....	76
Table 8	Factors and indicators of the relationship latent variable.....	100
Table 9	Factors and indicators of the School Satisfaction latent variable.....	113
Table 10	Bullying status of IB MYP students .....	121
Table 11	Total SDQ and SDQ subscale cut-off scores.....	144
Table 12	Proportion of male and female IB MYP students in each category of the SDQ by age group .....	146
Table 13	Mean SDQ scores of male and female IB MYP Students compared to Australian norms.....	147
Table 14	Summary of well-being findings.....	152
Appendix A Table 1	Flourishing (FloS) items .....	171
Appendix A Table 2	Mental Health Continuum (MentHC) items .....	172
Appendix A Table 3	Stirling Children’s Well-being Scale (StirCWB) items .....	173
Appendix A Table 4	Empathy items .....	174
Appendix A Table 5	Global Self-concept items .....	175
Appendix A Table 6	Self-Reflection items .....	175
Appendix A Table 7	Resilience items.....	176
Appendix A Table 8	Relationship items .....	177
Appendix A Table 9	School Satisfaction items.....	178
Appendix A Table 10	Peer Relations Questionnaire items .....	179
Appendix A Table 11	Strengths and Difficulties Questionnaire items .....	180

## Abbreviations

ABS	Australian Bureau of Statistics
CD-RISC	Connor-Davidson Resilience Scale
CEO	Catholic Education Office
CFI	Comparative Fit Index
DECD	Department of Education and Children's Development
FloS	Flourishing Scale (Diener et al., 2009)
FloS score	Flourishing score from Diener et al.'s Flourishing Scale
IB	International Baccalaureate
IRSED	Index of Relative Socio Economic Disadvantage
LSAC	Longitudinal Study of Australian Children
LWF	Learner Well-being Framework
MentHC	Mental Health Continuum (Keyes, 2006)
MIMIC	Multiple Indicators Multiple Causes
MYP	Middle Years Programme
RMSEA	Root Mean Square Error of Approximation
SBREC	Flinders University's Social and Behavioural Ethics Committee
SEIFA	Socio-Economic Indexes for Areas
SRMR	Standardised Root Mean Square Residual
StirCWB	Stirling Children's Well-being Scale (Liddle & Carter, 2010)
TLI	Tucker-Lewis Index
WBQ	Well-being Questionnaire



# Executive Summary

---

This is a report about the well-being of IB MYP students. Warren, Koen and Burrows (2011) have noted that well-being is a complex and multi-faceted concept. One approach to conceptualising well-being is to consider the two concepts of the “hedonic tradition”, with its emphasis on “happiness”, and overall “satisfaction with life” and the eudaimonic tradition, which typically highlights positive psychological functioning, including self-actualisation and life achievement. Generally defined, individuals can be said to possess a state of well-being when they have the psychological, social and physical resources they need to meet a particular psychological, social and/or physical challenge (Dodge, Daly, Huyton, & Sanders, 2012).

In turn, the philosophy underpinning the International Baccalaureate, which encompasses an holistic view of education, has deep connections with the ideas behind not only personal achievement in the academic sphere, but also social and emotional learning. As Warren et al. (2011) have noted, there is a mutual synergy between well-being and learning in general. More particularly, social and emotional learning is considered to play a key role in the IB MYP curriculum to develop knowledgeable, balanced and caring students, and IB schools are encouraged to increase their focus on social and emotional learning in the classroom. This is consistent with approaches in broader educational contexts, such as the South Australian Department of Education Learner Well-being Framework (DECD, 2013).

Linked to concepts of well-being are current policy imperatives to promote positive mental health, for adults and for young people from birth to Year 12. The Council of Australian Governments' National Action Plan for Mental Health 2006-2011 (DoHA, 2010) and the more recent roadmap for National Mental Health reform (2012-2022) (COAG 2012) identify the “promotion, prevention and early intervention” for positive mental health as their first Action Area. Schools are identified as strategic settings, and teachers are key agents, for mental health promotion for young people (Askill-Williams & Cefai, 2014; WHO, 2013a; 2013b).

In the general community, and in the extant literature, the concepts of mental health and well-being are often used inter-changeably: This is in part due to the challenges both terms present in terms of their definitions. In this report particular care has been taken to identify when reference is made to broad measures of student well-being, and when referring to measures that focus more specifically upon mental health. As Keyes (2006) has noted, the mental health continuum ranging from languishing, to moderate mental health, to flourishing, differs from the presence of mental ill-health or disorder, such as depression or anxiety.

## Background to the Study

The Flinders University School of Education has an established IB research team working in partnership with local schools researching the impact of IB programmes. Located within the School of Education are two areas of strategic research focus, namely, the Flinders Educational Futures Research Institute, and the Centre for Student Well-being and Prevention of Violence. Researchers in these clusters of research strength have extended experience in undertaking national evaluations of curriculum and mental health promoting initiatives such as MindMatters, KidsMatter Primary<sup>1</sup> (Slee et al., 2009) and KidsMatter Early Childhood<sup>2</sup> (Slee et al., 2012) as well as other international social and emotional well-being studies.

## The Research Questions

This evaluation addressed the following broad research questions:

- What is the social-emotional well-being of students participating in the IB Middle Years Programme?
- Does social-emotional well-being vary by age/year level?
- Does social-emotional well-being vary by gender?
- Does social-emotional well-being vary by school type?
- What are the key success practices and supports for promoting positive social-emotional development undertaken by schools?
- To what extent do schools align their practices to support student social-emotional development with the attributes of the IB learner profile:
  - According to staff?
  - According to students?

## Methodology

A mixed method design was used to address the research questions, including measures that provide an indication of students' flourishing, social, emotional and psychological well-being, empathy, global self-concept, reflection, resilience, relationships, school satisfaction and mental ill-health. Measures of all of these constructs were combined into a Well-being Questionnaire, with 144 items. This questionnaire was

---

<sup>1</sup> [www.kidsmatter.edu.au/sites/default/files/public/kidsmatter-full-report-web.pdf](http://www.kidsmatter.edu.au/sites/default/files/public/kidsmatter-full-report-web.pdf)

<sup>2</sup> <https://www.kidsmatter.edu.au/sites/default/files/public/KMEC%20Evaluation%20Full%20Report%20WEB.pdf>

administered to students in Term 3, 2013, following a small pilot study that assessed the procedure and language used in the questions. Interviews and focus groups with students and staff were also conducted. In total 1,930 IB MYP students and 13 staff from eight South Australian IB MYP schools participated in the study. A strength of this study was the triangulated process used to measure well-being.

## Summary of Findings

### IB MYP Student Well-being

The findings suggest that IB MYP schools are making concerted efforts to build the empathy, global self-concept, peer relationships, school relationships, self-reflection, resilience and the confidence of IB MYP students and only a small proportion of IB MYP students showed poor levels of well-being.

Due to the broad conceptualisation of well-being in the general and in the academic community, three different, but complementary, measures were selected to determine the well-being of IB MYP students. Diener et al.'s (2009) Flourishing Scale and Keyes's (2006) Mental Health Continuum enabled two separate measures of *flourishing*, each using different indicators. (As described more fully later in the body of the report, "flourishing" is considered to involve functioning effectively and feeling good about oneself.) Meanwhile Keyes's (2006) Mental Health Continuum and Liddle and Carter's (2010) Stirling Children's Well-being Scale enabled measures of *languishing and poor mental health*. These latter two scales also allowed for measures of moderate mental health, positive outlook and emotional states of IB MYP students in the study. Moderate mental health is a state of well-being where individuals are considered to be functioning satisfactorily. Individuals with moderate mental health are not languishing and although they have the potential, they are yet to flourish.

We found that 92% - 94% of participating IB MYP students showed good to moderate well-being, while 54%-55% were flourishing and 6%-8% were languishing. A similar study by Keyes's (2006) of 1,234 American young people aged 12-18, found that 38% were flourishing, 6% were languishing and the remainder (56%) were moderately mentally healthy.

### *IB MYP Students Flourishing*

The results suggest that nearly two thirds of the IB MYP students were flourishing using Diener et al.'s (2009) Flourishing Scale. Results from this scale indicated that 55.3% of IB MYP students were classified as flourishing using an assigned cut-off score of 40 (students with a score of 41 or more were classified as "flourishing"). In addition, a composite measure using selected items in Keyes's (2006) Mental Health Continuum (MHC) identified 54.1% IB MYP students as flourishing, indicating that the two measures are consistent on this concept. Keyes's MHC also showed that nearly two in five (39.7%) of IB MYP students

could be described as having moderate mental health. We concluded that 54%-55% of IB MYP students were flourishing (i.e. functioning well and feeling good about themselves) while 92% - 94% had moderate well-being or were flourishing (see Table 1).

### *IB MYP Students Languishing*

We found that 6.1% of IB MYP students could be categorised as languishing using Keyes’s (2006) Mental Health Continuum (see Table 1). As noted by Keyes (2006) a person who is languishing does not necessarily experience a mental health disorder or mental ill-health.

Furthermore, Liddle and Carter (2010) suggested that Stirling Children’s Well-being scores that were less than 30 were an indication of poor mental health. We found, as shown in Table 1, that 8.4% of IB MYP students had scores in this lower range, indicating the two measures are consistent on this concept. Based on these results we concluded that approximately 6%-8% of IB MYP students were languishing. As noted above, this proportion is not an indication of the number of individuals with mental ill-health or disorders. While this research was a cross-sectional study undertaken at one point in time, a consideration of school systems would be to assist all students reach a state of “flourishing”.

### *IB MYP Students with a Positive Outlook and a Positive Emotional State*

Liddle and Carter’s (2010) Stirling Children’s Well-being Scale comprises two subscales which measure positive outlook and a positive emotional state. We found that over half (60.1%) of IB MYP students were experiencing a positive outlook and just over half (52.4%) were experiencing a positive emotional state “quite a lot” or “all of the time”. Furthermore, an additional 32.2% and 35.6% of IBMYP students were experiencing a positive outlook or positive emotional state (respectively) “sometimes” (see Table 1). Overall, the well-being of 91.6% of IBMYP students was above the cut off level of poor mental health.

**Table 1** Summary of well-being findings

Measure		Total Proportion	Males	Females
<b>Flourishing Scale</b> (Diener et al.)	Flourishing (FloS)	55.3%	59.8%	50.9%
<b>Mental Health Continuum</b> (Keyes) (Composite measure)	Flourishing (MentHC)	54.1%	59.7%	47.8%
	Moderate Mental Health (MentHC)	39.7%	36.0%	44.0%
	Languishing (MentHC)	6.1%	4.4%	8.1%
<b>Stirling Children’s Well-being Scale</b> (Liddle & Carter)	Poor mental health (StirCWB)	8.4%	5.2%	12.0%
	Positive Emotional State (StirCWB) - always	52.4%	58.3%	45.8%
	- sometimes	32.2%	27.6%	37.4%
	Positive Outlook (StirCWB) - always	60.1%	66.9%	52.4%
	- sometimes	35.6%	33.1%	38.4%

## IB MYP Student Profile

Student attributes considered to be associated with well-being were also examined in the study. These included cognitive and affective empathy, global self-concept, self-reflection, relationships and resilience. It was important to distinguish cognitive and affective empathy as Sutton, Smith and Swettenham (1999) have suggested, and as found in our research, that cognitive empathy is associated with positive features such as productive perspective-taking, but can also be associated with some forms of bullying. Overall, nearly one quarter of IB MYP students indicated high levels of empathy. Affective empathy (the ability to understand another's feelings) was present in just over half of the IB MYP students and this was more prevalent than cognitive empathy. Affective empathy was found to be associated with well-being and cognitive empathy was not.

The results showed that

- just over half (52.2%) IB MYP students reported that the descriptors of affective empathy were “very” or “fairly like” them.
- nearly two in five (39.4%) IB MYP students reported that indicators of cognitive empathy were “very” or “fairly like” them.
- more than half (61.0%) IB MYP students reported a positive sense of global self-concept “always” or “most of the time”. Moreover, the proportion was 90.5% when students who report a positive global self-concept “sometimes” (29.5%) are included.
- nearly three-quarters (74.6%) of IB MYP students in our sample indicated that they were engaging in self-reflection.
- just over half (53.3%) of IB MYP students reported that they felt resilient “often” or “nearly all the time”. The resilience levels of IBMYP students were comparable with those found by Lim et al. (2011) of 190 adolescents, aged 12-16, from a public mainstream secondary school in Singapore.

## IB MYP Student Satisfaction with School

Measures of student satisfaction with school indicated that most IB MYP students were happy (approximately 70%) and satisfied (approximately 80%) with school. Most IB MYP students reported that they enjoyed school (72.0%), enjoyed learning (69.7%), felt supported by their school (70.8%) and had a sense of fellowship at school (80.1%).

Nearly one in five (19.2%) of IB MYP students reported being bullied once a week or more often and this number was lower than the 22.7% of South Australian students of similar age reported in a study by Slee



(2005). Our study also found that affective empathy was more likely to be associated with being bullied less and a lower likelihood of bullying others. Affective empathy was an attribute in over half of IB MYP students and therefore low rates of bullying would be consistent with this.

## School Success Practices

The Well-being Questionnaire (WBQ) open-ended question asked students to draw a picture or write about how their school helps them to be successful. Responses to this task were provided by 84.3% of participants. Of these, just over four in five (82.2%) provided positive comments about the school, while 6.2% were negative, and 11.0% were pictures or remarks which could not be classified as positive or negative, but were considered “mixed”.

During the focus groups IB MYP students generally acknowledged that their school was making an effort to assist students to succeed at goals identified as important to students. Both students and staff conceptualised success as the achievement of goals that varied between students and extended beyond academic achievement. School staff clearly recognised the inextricable link between success and well-being and they identified a number of enablers of success. These included providing a safe and secure environment, attending to student well-being, ensuring good relationships with students and parents, empowering students, building student skills, possessing a culture of success, having a collaborative staff and supporting students with resources. Staff generally attributed factors independent of the school, such as parent and student characteristics and expectations, as barriers to success.

## Mental Ill-health

The Strengths and Difficulties Questionnaire (SDQ, Goodman, 1997) was used as a screening instrument to identify indicators of mental ill-health amongst students. When males and females were divided into age groups, a comparison with Australian norm data found that, with one exception (i.e. females aged 14-16), IB MYP students' SDQ scores fell within the normal range of mental health. However, for a small group of females in the upper years of MYP, emotional symptoms and total SDQ scores were “of concern” as these scores fell outside of one standard deviation from the Australian means for this age group of females. Our research did not extend to an investigation of why the females in this study reported experiencing emotional difficulties in their SDQ responses. More research would be required to explore this issue further. This is a significant finding of the present study in the light of some tentative emerging evidence that adolescent females nationally and internationally are reporting more mental health problems than boys.

## Gender Differences

Male and female IB MYP students were found to differ on nearly all measures included in the WBQ, with some exceptions.

Males and females showed no significant differences in self-reported levels of serious bullying, in their relationships and in their general happiness at school. Males and females did not differ in their enjoyment of school, in their enjoyment of learning and in their sense of fellowship at school.

Overall, males' self-reported scores were higher than females on all well-being measures (i.e., the Keyes; Deiner et al.; and Liddle & Carter scales). Males were more likely than females to report that they were flourishing, had a positive outlook and had a positive emotional state. In contrast, females were more likely to report that they were languishing and had moderate mental health. Gender differences of this kind are not an uncommon finding in mental health and well-being studies. For example, very recent unpublished results from Scotland using the StirCWB Scale also indicate a trend for more girls than boys to report poor mental health (P. Davidson, 8/4/2014) and research by Green, McGinnity, Meltzer, Ford and Goodman (2005) of 11 to 15 year olds in the UK found emotional disorders were higher in girls (4.1%) than boys (3%). Another recent study of the status of girls in Indiana, USA, by Kuter & Deom (2013) reported that daily feelings of sadness or hopelessness were more likely to have been conveyed by females than males. The Indiana study also found that the percentages of girls reporting these dispositions increased from grade six to grade eight or nine and then decreased.

Compared to males, females reported greater levels of cognitive and affective empathy and self-reflection, but males generally reported more resilience and higher global self-concept. Males were more likely to report school satisfaction, and that they felt supported by their school more than females.

## Differences Between Year Levels

Differences between IB MYP students according to Year level were apparent across all measures in the Well-being Questionnaire. Students in the lower years of MYP (Years 6 & 7) generally showed greater levels of well-being than students in the upper years of MYP. These students were more likely to report that they were flourishing, had a positive outlook and a positive emotional state than older students. However, while younger students reported higher levels of cognitive and affective empathy, the differences were statistically significant only between Year 6s and other Year levels. Following a small drop in scores in Year 7, cognitive and affective empathy were relatively stable across the middle years.

Younger students reported higher levels of global self-concept, self-reflection, resilience, positive relationships, and school satisfaction than older students.

IB MYP students' reports of being bullied 'once a week or more often' were higher in the lower years of MYP than in the upper years of MYP.

### *Females in the Upper Years of IB MYP*

An interaction effect of gender and year level was evident in many of the well-being measures in our study and quite often it was apparent that this effect was associated with reports from some females in the upper years of IB MYP. Generally, compared to younger females and males, females in the upper years of IB MYP were more likely to report that they were languishing and were more likely to have moderate mental health, but less likely to be flourishing. These findings are consistent with those found by Kuter and Deom (2013) of girls in Indiana, USA (as reported above).

In our study, females in the upper years of MYP tended to have the lowest scores on measures of positive outlook, a positive emotional state, global self-concept, relationships and resilience. Females in the upper years of MYP were more likely to show signs of emotional symptoms that were "of concern". Our study also found qualitative evidence to suggest that some females in the upper years of MYP were not faring well; feeling unhappy, disheartened and unsupported by their school.

### **Factors Associated with Well-being**

Structural Equation Modelling (SEM: MPlus) was used to examine student attributes considered to be associated with well-being. Predictors of well-being that were tested in the SEM models included cognitive and affective empathy, global self-concept, self-reflection, relationships and resilience. We found that

- affective empathy was not a good predictor of well-being, which was measured using FloS, MentHC and StirCWB, indicating that the presence of affective empathy is not associated with high levels of well-being. However, affective empathy was found to be a negative predictor of involvement in bullying as a victim or a bully.
- cognitive empathy was a poor and negative predictor of well-being. In addition, we found that the presence of cognitive empathy was associated with the likelihood of involvement in bullying as a victim or bully.
- global self-concept was a significant predictor of well-being. Global self-concept was a significant predictor of flourishing, suggesting that students with high levels of global self-concept were the most likely to be flourishing. Similarly, global self-concept was a significant predictor of the components of well-being comprising the MentHC and it significantly predicted emotional, psychological and social well-being. The analyses suggest that global self-concept may be an important element in social well-being, having a positive outlook and a positive emotional state.

- self-reflection without insight and self-acceptance, did not significantly influence well-being.
- resilience was a good predictor of well-being. We found that resilience was associated with flourishing, social, emotional and psychological well-being, as well as having a positive outlook and a positive emotional state. The more resilient the student, the more likely he or she would report these facets of well-being.
- positive relationships were strongly associated with flourishing, social, emotional and psychological well-being, as well as having a positive emotional state and a positive outlook. The findings suggest that friendships, being pro-social as well as positive relationships at school are important factors for well-being. The qualitative findings support these results.

The study findings indicate that global self-concept, relationships and resilience are more strongly associated with well-being than affective and cognitive empathy and self-reflection, and suggest that schools could improve student well-being by focusing on the former, rather than the latter, elements.

## Study Limitations

While we endeavoured to find a representative sample of IB MYP students using purposive sampling, our statistical analysis indicated that representation of students from low SES backgrounds was insufficient in our sample. Our findings are more likely to reflect the circumstances of students from middle and upper SES groups. However, it is not clear whether such a group is representative of IB MYP students in South Australia, where the IB MYP is available in schools that cater to families with low socio-economic status. Nonetheless, caution must be exercised if our findings are used to interpret other contexts.

The data for this study was generated from self-reports and while some self-report forms have been found to be reliable and valid (e.g. Goodman's (2001) SDQ), and it can be predicted that students would be good informants about their own feelings and subjective well-being, future research could triangulate assessments from other informants such as teachers and parents/guardians.

Study data were gathered from a cross-section of respondents at a single point in time, so any inferences of cause-and-effect relationships cannot be considered definitive (Creswell, 2012). Future studies could contribute to our understanding of changes in student well-being across the middle years by undertaking a longitudinal study with the same respondents, over a number of years.

## Summary and Conclusions

Overall, this exploratory study has provided a wealth of information about IB MYP students' well-being in association with a range of indicators, including global self-concept, resilience and relationships. While, on the whole, the results indicate that IB MYP students are faring well, our study shows that a small group of

females in the upper years of MYP warrant special attention if their social and emotional needs are to be addressed. The invaluable information from this study can be used to inform future IB MYP initiatives, particularly enabling students' attainment of the IB Learner Profile.

# Introduction

---

This is a report about the social, emotional and psychological well-being of International Baccalaureate (IB) Middle Years Programme (MYP) students, and success practices in IB schools.

The IB offers four programmes of international education designed for children between the ages of 3 and 19 years. The Primary Years Programme (PYP) has been developed for students aged 3 to 12; the Middle Years Programme (MYP), which is relevant to the current study, has been designed for students aged 11 to 16, while the Diploma Programme (DP) is a two-year course for senior students aged 16 to 19. More recently the IB added the Career-related Certificate (IBCC), for students aged 16 to 19. While IB programmes have been taken up by more than one million students in 146 countries ([www.ibo.org/](http://www.ibo.org/)), the original objective of the IB curriculum was to address the needs of students who were internationally transient.

Research undertaken in the last decade has established that supporting the social-emotional development of students in the middle-years students enhances academic and social outcomes for individuals during schooling as well as later in life (Durlak, Weissberg, Dymnicki, Taylor & Schellinger 2011). However, studies undertaken to assess levels of social-emotional well-being among students completing International Baccalaureate programmes (e.g. Tan & Bibby, 2011) are sparse. To contribute further knowledge to this important area, the current study used validated and commonly-used instruments to measure the well-being of students enrolled in the IB MYP programme.

Our objective was to assess the social, emotional and psychological well-being of students experiencing the IB MYP. The findings provide an indication of whether IB MYP students have been flourishing or languishing, and their general level of social, emotional and psychological well-being.

Qualitative and quantitative methods were used to collect data from nearly 2,000 IB MYP students from eight schools offering the IB MYP in South Australia. The research questions central to our study were aligned with the key deliverables in the contract between Flinders and the IBO. The collection of data was designed to inform the following research questions:

- What is the social-emotional well-being of students participating in the IB Middle Years Programme?
- Does social-emotional well-being vary by age/year level?
- Does social-emotional well-being vary by gender?
- Does social-emotional well-being vary by school type?

- What are the key success practices and supports for promoting positive social-emotional development undertaken by schools?
- To what extent do schools align their practices to support student social-emotional development with the attributes of the IB learner profile:
  - According to staff?
  - According to students?

The study began with the quest to find suitable instruments for measuring well-being that were appropriate for students in the IB MYP age, ranging from 11 – 16 years.

## Mental Health and Well-being

Typically in the past, research has equated the health and well-being of young people and adults with the absence of malfunctioning and disturbance, and one's mental health was considered satisfactory if a mental health disorder was not diagnosed. However, a more positive approach involves an assessment of well-being by considering the presence of positive feelings toward one's life and the level of functioning well in life (Keyes, 2006).

The state of mental health of a population is considered to occur across a spectrum (Keyes, 2006). Occurrences of mental ill-health, where individuals experience unhappiness and difficulties, but whose conditions do not meet the DSM-5 (Diagnostic and Statistical Manual of Mental Disorders, American Psychiatric Association, 2013) criteria, are not diagnosed with a mental health disorder, rather they are considered to be languishing (Keyes, 2002). Languishing is a state of being which occurs at the lower end of the spectrum, while individuals with the most positive state of mental health are considered to be flourishing and are positioned at the high end of the spectrum. Moderate mental health, which according to Keyes (2006) is experienced by most of the population, is located between languishing and flourishing on this spectrum. Boundaries between these well-being states are blurred and loosely defined. The mental health of an individual is situated at one point along this spectrum at any given point in time, although one can move along the spectrum at different stages of their lives.

The perspective taken in our research was to consider the state of well-being of IB MYP students to determine whether students were flourishing, experiencing moderate mental health or languishing. This perspective is in accord with the views of Kazdin (1993) and Roeser, Eccles and Strobel (1998), which have conceptualised mental health as consisting of two dimensions, namely a) the absence of dysfunction (impairment) in psychological, emotional, behavioural and social spheres, and b) the presence of optimal

functioning in psychological and social domains. In this regard we considered, as Keyes (2006) has suggested, that mental health viewed in this way is a good indicator of well-being.

## Measuring Well-being

An empirical assessment of well-being requires the use of a suitable valid and reliable measuring instrument. In recent years several surveys have been undertaken by researchers in different countries to measure children's and adolescents' well-being. Examples of these studies include the *Children's Society study of children's subjective well-being in England* (Rees, Goswami, & Bradshaw, 2010), *Growing up in Ireland* (Greene et al., 2010), *Growing up in Australia (LSAC)* (Sanson et al., 2005), *Children's Worlds* <http://www.childrensworlds.org/home>), *The Health and Well-being of Secondary School Students in New Zealand* (Denny et al., 2008) and the *Young Lives* study (Camfield, Streuli, & Woodhead, 2009). While all the studies, in different ways, measure young people's well-being, the area of interest and focus varies between them. The *Children's Society* and *Children's Worlds* studies, for example, focus on understanding children's lives from their perspectives; the *Growing up in Ireland* and *Growing Up in Australia (LSAC)* studies are interested in child development, and the *Young Lives* study focuses on childhood poverty.

There appears to be limited consensus on how young people's well-being should be measured. According to O'Hare and Gutierrez (2012) "most analysts have conceptualized child well-being as a broad concept involving multiple dimensions" (p. 6), although there seems to be no agreement about what comprises those dimensions or how many they number in total. While difficult to measure, Lau and Bradshaw (2010) have argued that *subjective* well-being is the essence of well-being to which other domains, such as health and social/family connections, merely contribute.

Following a humanistic, positive psychology perspective, Diener et al. (2010) focused on flourishing as an important aspect of well-being and they developed a Flourishing Scale "to complement existing measures of subjective well-being" (p. 144). Diener et al.'s scale was developed by considering human psychological needs associated with well-being. These included one's need to feel competent, to have meaningful social relationships, to experience self-acceptance, to help others, be optimistic and to experience purposeful and meaningful activities. In their evaluation of the Flourishing Scale Diener et al. (2010) found that it was strongly associated with mastery and competency. While the scale includes the essential components of the theories linked to well-being, it does not measure social and psychological well-being as separate elements. Although the Flourishing Scale is useful for measuring psychological flourishing, Diener et al. (2009) suggested that additional scales are needed if more than just an overall psychological well-being measure is required. Acknowledging this limitation, we used additional scales in our study, which included Keyes's (2006) Mental Health Continuum and Liddle and Carter's (2010) Stirling Child Well-being Scale.



In his consideration of subjective well-being, Keyes (2006) surmised that “the study of subjective well-being has been divided into two streams of research, one that equates well-being with happiness and the other with human potential that, when realized, results in positive functioning in life” (p. 4). The first stream, Keyes suggested, follows the “hedonic tradition” and is related to emotional well-being, while the second “is the tradition of eudaimonia” (p. 5) and is associated with social and psychological well-being. Whereas in the first approach individuals are concerned with their happiness and general satisfaction with life, in the second approach individuals are more concerned about their abilities and capacities in becoming well-functioning persons and citizens. Keyes proposed that young people are flourishing when they show a high level on at least one indicator of hedonia (emotional well-being) and just over half of the indicators of eudaimonia (social and psychological well-being), languishing when levels of hedonia and eudaimonia are low, and moderately mentally healthy otherwise. Keyes refers to the instrument he developed as the “Mental Health Continuum” (MHC). The short form of this instrument contains three subscales that measure emotional, psychological and social well-being. Together, the scales provide an indication of whether individuals are flourishing, languishing or have moderate mental health.

The Stirling Children’s Well-being Scale is another measure of well-being. Unlike the Flourishing Scale and the Mental Health Continuum Scale, which are adaptations of adult well-being instruments, the Stirling Child Well-being Scale was developed by Liddle and Carter (2010) specifically for young people aged 8-15. The Stirling Child Well-being Scale comprises two subscales of emotional and psychological well-being as well as a social desirability subscale (to identify biased responders). Based on a positive psychological perspective, items in this scale are positively worded and incorporate aspects of life in general.

Results from the three scales provide a good indication of the social, emotional and psychological well-being of IB MYP students as well as whether or not they are generally flourishing, languishing or have moderate mental health.

In this study we also used an instrument, the Strengths and Difficulties Questionnaire (SDQ, Goodman, 1997) commonly used by researchers around the world to screen young people for mental health disorders (Goodman and Goodman, 2011). We were aware that Australian norms (Mellor, 2005) were available for this traditional approach for assessing young people’s mental health, while they were not (yet) available for the well-being measures used in this study. The SDQ we reasoned would enable comparative measures of the mental health strengths and difficulties of IB MYP students with similarly aged Australian students. We stress however, that the SDQ does not provide an indication of well-being. Rather, it indicates whether or not the young person being assessed is in need of follow-up intervention for a mental health disorder.

## Well-being in the International Baccalaureate (IB) Context

Encompassing an holistic view of education, the IB provides an educational structure that stresses the development of the whole student and the advancement of a well-rounded individual who is not just competent academically. The IB has a commitment “towards a comprehensive education stressing the importance of emotions and learning techniques in addition to focusing on academic skills and community building” (p. 27). The learning goals of the IB aim to help students develop respect for themselves, others and the world around them. The IB defines 10 attributes in the IB Learner Profile (LP) that students should strive to achieve and which are considered important assets to be acquired by students as part of their personal development. In all of the IB programmes, learners are encouraged to strive to become *Inquirers*, who are *Knowledgeable, Thinkers, Communicators, Principled, Open-minded, Caring, Risk-takers, Balanced* and *Reflective*. As such, the IB LP has deep connections with the ideas behind social and emotional education for students and many of the traits comprising the IB Learner Profile are conducive to the development of social and emotional well-being (Hannah, 2011). We sought in our study to investigate some of the IB LP attributes and their relationship to well-being. We focused on three attributes in particular, namely being ‘caring’, ‘balanced’ and ‘reflective’ as three aspects of the LP that have been shown to relate to well-being. In relation to these attributes we examined empathy, global self-concept, and self-reflection, and we examined the importance of each of these constructs as predictors of flourishing as well as social, psychological and emotional well-being. We were interested in exploring how the IB LP attributes would give rise to social, emotional and psychological well-being.

While not specifically referred to as part of the LP resilience is another attribute inherent in the IB MYP that seeks to advance a self-regulated learner to effectively deal with and respond positively to any setbacks and difficulties, and to make changes and persevere (IBO, 2013). In this regard, we also examined resilience to determine its relationship to well-being.

Specific approaches to learning (ATL) are defined by the IB to promote affective, collaborative and communication skills that build positive communities and engender social and emotional well-being (IBO, 2013). Good relationships are integral to the development of international mindedness and well-rounded individuals who have self-respect and respect for others. The importance of relationships for well-being is well documented in the literature (e.g., Gibb, 2003; Lyubomirsky, Sheldon, & Schkade, 2005; Nangle & Erdley, 2001; Rubin, Bukowski, & Parker, 2006; Wentzel, 2009) so we also explored the association of personal relationships with social, emotional and psychological well-being in this study.

Our aim in examining some of the LP attributes and associated personal skills (such as resilience and relationships) with well-being was to explore the impact of these non-academic skills on the social, emotional and psychological well-being of IB MYP students.

## The South Australian Context

Participants in our study were located in South Australia (SA) and in the metropolitan area of its capital in the city of Adelaide. It is important to acknowledge this context and to explain the emphasis placed on student well-being by the SA education system directed by the Department for Education and Child Development (DECD) that created the “Learner Well-being Framework” for government schools.

## DECD Learner Well-being Framework

The DECD recognised the relevance of student well-being to learning in 2007 and it introduced the “Learner Well-being Framework” (LWF) for birth to year 12. The approach aims to provide a well-being framework which supports schools in improving their practices and enhance learner well-being. The framework was based on current knowledge about learner well-being and is grounded in local practice. Seven of the secondary schools that offer IB MYP to students in South Australia are government schools where the learner well-being framework is implemented. Three of those schools participated in our study.

The DECD learner well-being framework, represented in Figure 1, represents a systems perspective whereby influences on child and youth well-being are located at the psychological micro-level of the child, contextual influences at the meso-level, such as environments that foster social relationships, and macro level influences such as policies and community practices. At the heart of this approach is an understanding that well-being is central to learning and that learning is central to well-being; when

learners are in an optimum state of well-being they will engage more readily with learning. Five dimensions comprise the Learner Well-being Framework.

As shown in Figure 1, they are cognitive, emotional, physical, social and spiritual. Together, these elements provide students with resilience and confidence, which facilitates learning (DECD, 2013). To enhance well-being, the five dimensions of well-being need to be incorporated in the context of the domains of the learning environment, curriculum and pedagogy, partnerships, and policies and procedures of the school or

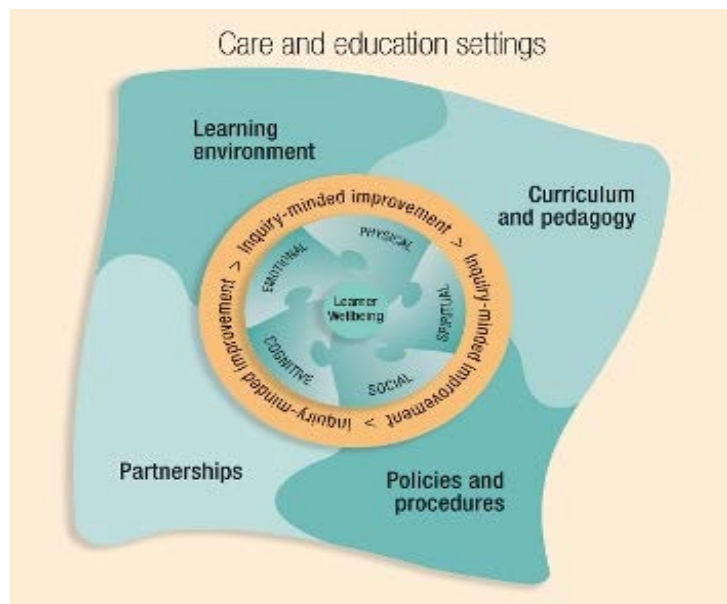

Figure 1 DECD Learner Well-being Framework

educational site (DECD, 2013). The approach also recognises that educators can make a positive contribution to well-being and that well-being is built on the strengths of individuals, groups and communities working together (DECD, 2013). Schools and educational sites in SA are encouraged to focus on learner well-being in their site improvement plans.

The DECD learner well-being framework and the IB Learner Profile share a similar rationale, as IB MYP schools “are encouraged to consider the social and emotional needs of students in teaching and learning, in addition to their academic needs” (IBO, 2013). Both approaches promote the development of the whole person beyond academic and intellectual achievement and recognise the importance of “balance” in learning. The two approaches complement each other and would work in synergy to enhance student well-being. We would not consider that the presence of the learner well-being framework in a school would operate in opposition to, or in the place of, the IB learner profile, but rather it reinforces the principles that underlie the IB MYP.

## **Ethics Approvals**

Ethical approval to conduct this study was obtained from a number of educational jurisdictions including the Department of Education and Children’s Development (DECD) for permission to conduct the research in South Australian government schools and the South Australian Catholic Education Office (CEO) to carry out the study in South Australian Catholic Schools, as well as from Flinders University’s Social and Behavioural Ethics Committee (SBREC). Since the South Australian independent schools in this study accept ethics approval from SBREC, they did not require a separate ethics application. Following ethics approvals, approval of each School Principal was gained for the study to be conducted in his or her school.

## **Structure of this Report**

The findings of our study are presented in a number of separate chapters. This is to avoid confusion of the three different measures used to assess IB MYP student well-being. In our study, well-being was measured using Diener’s Flourishing Scale (FloS), Keyes’s Mental Health Continuum (MentHC) Scale and the Stirling Children’s Well-being Scale (StirCWB) developed by Liddle and Carter. Findings from these approaches are presented in the first three chapters of the results i.e. Chapters 3-5 respectively.

The next section of the report examines some Learner Profile attributes and their relation to well-being. Findings of student attributes such as empathy, global self-concept, reflection and resilience are presented. Results of self-reported school satisfaction and bullying are presented next, followed by findings from the qualitative study of school success practices and from an open-ended question in the Well-being

Questionnaire. Findings from an investigation of mental ill-health, measured using Goodman's (1997) Strengths and Difficulties Questionnaire (SDQ), are provided in the subsequent chapter.

Each of the chapters provides the findings as well as the theoretical background of the instruments, scale psychometrics, and a discussion of the results and limitations. In some chapters, quotes and student drawings from the qualitative study are provided as illustrative examples. Finally, a summary and discussion of the findings are discussed in the last chapter.

# Procedures

---

## Data Collection

Unlike other Australian states, South Australia (SA) boasts a high number of IB MYP schools. Of the 43 Schools listed on the IBO website as offering IB MYP in Australia, 25 (58.1%) are located in South Australia. There are 16 secondary schools in SA that offer IB MYP across the three educational jurisdictions. Nearly half (43.8%) of the secondary schools with IB MYP in SA are government schools, while the remaining third (37.5%) are independent schools and a small proportion (18.8%) are all-girls or co-educational Catholic schools. The presence of such a range of IB MYP schools provided a good sampling pool for participant recruitment.

## Method

The research utilised a mixed approach incorporating both quantitative and qualitative methodologies (see Figure 2). A survey of IB MYP students using the purpose built Well-being Questionnaire provided quantitative data that allowed inferences and comparisons to be drawn from statistical procedures. The qualitative data collection involved focus groups with students and interviews key IB MYP staff, including IB MYP coordinators, well-being coordinators, school counsellors and principals.

## Students as Informants

Asking young people to participate in the process of assessing their well-being has become, according to Ben-Arieh (2008), “both a prerequisite and a consequence of the changing field of measuring and monitoring child well-being” (p.13). It is a process that speaks to the principles inherent in the United Nations Convention on the Rights of the Child (CRC), which offers a normative framework for understanding young people’s well-being through direct consultations with them (Ben-Arieh, 2008). Such processes are necessary in order to inform policies that effectively promote the well-being of young people, as the inclusion of their voices is more likely to lead to policies that are in accord with young people’s understanding of their own well-being (Fattore, Mason & Watson, 2009).

The approach used in our study involved an assessment of MYP students’ well-being through the use of a self-report questionnaire that contained sub-sections targeting the various aspects of subjective well-being discussed above. To enhance opportunities for the expression of “student voice” about their well-being, and

the support they felt was provided at school, our study also included focus groups where MYP students were offered an opportunity to discuss student well-being and school success practices.

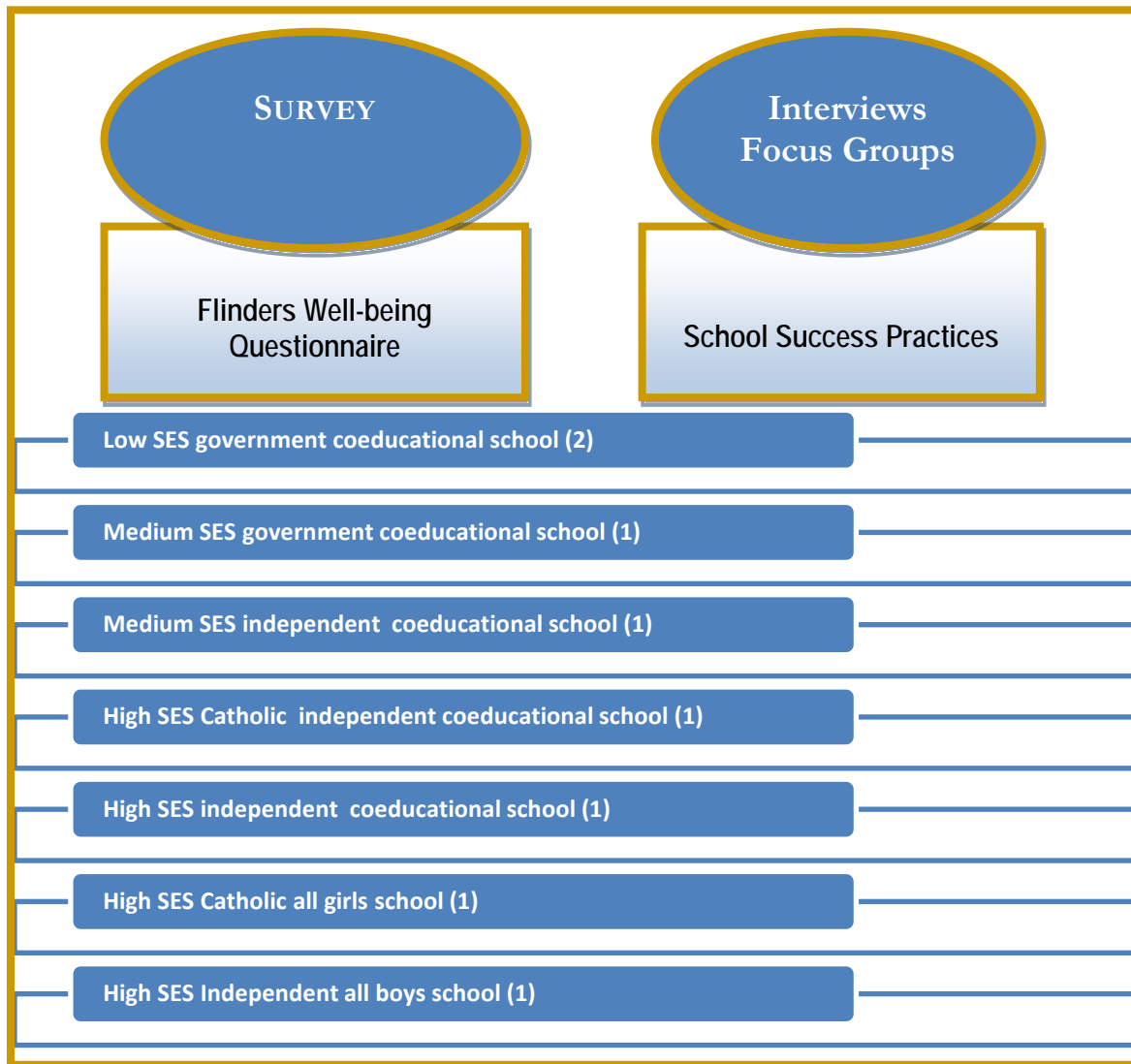

Figure 2 Mixed method study design

## Well-being Questionnaire (WBQ)

Standard validated and well-used instruments that were readily available and could be used in future follow-up studies were selected for the purpose built questionnaire used in the survey. Questionnaire items specific to the IB learner profile (as discussed above) were also included. The WBQ comprised 10-pages of questions, one page of instructions and a page thanking students for their contribution and providing a list of free services for any concerns raised from having participated in the survey. The penultimate version of the questionnaire was tested in a pilot study.

## Pilot Study of the WBQ

The WBQ was tested with six students attending a co-educational independent school located in a medium-high socio-economic area of Adelaide. The students had obtained parental consent to participate in the pilot study. The feedback provided by participants in the pilot study enabled us to refine the questions and make them more suitable for Australian adolescents.

Students in the pilot study were asked to fill-in the questionnaire and indicate which questions did not make sense or were difficult to interpret so that we could check that questions had been worded correctly and were easy to understand. Participants were instructed:

*Please tell us what you think about the questions. For this pilot study, we would like you to tell us if say, you think a question was confusing, not clear or if you had trouble answering it, and then we would like you to say why. The information you provide will be used to help us ensure that the questionnaire is suitable for students your age.*

A researcher recorded the time taken to complete the questionnaire and found that most of the students had completed it within 23 minutes. Feedback from the students suggested that a few items required rewording in order to facilitate understanding. For example, the question: “I always share my sweets” was changed to “I always share my lollies/ sweets/ treats” in order to better align it to the Australian context.

Some of the questions that students found confusing could not be modified as they were taken from existing validated questionnaires that the authors had stipulated could not be changed. An example of a question that could not be reworded was: “I am able to adapt when changes occur”. To ease understanding without altering the question, this item was rephrased as “I am able to adapt (adjust) when changes occur”.

Besides these few comments, students generally found the questionnaire easy to understand and relatively simple to complete. Once the modifications were made, the questionnaire was reformatted and printed.

## Final WBQ

The final WBQ, which comprised 144 questions, was organised across 10-pages to facilitate scanning. It began with questions about school that students were expected to answer easily.

The WBQ comprised the following sections:

- **School satisfaction** questions (12 items) adapted from questions used in the Longitudinal Study of Australian Children (LSAC) and the School Index (Tomyn & Cummins, 2011), as well as eight items developed by the researchers to encompass school belonging and relationships. All items were on a 7-point Likert Scale ranging from “very strongly disagree” to “very strongly agree”. These questions were used to assess school satisfaction of IB MYP students.



- A question indicating **“school contentment”** using an adaptation of Andrews and Withey’s (1976) face scale, as shown below. Aggregated responses from this item were compared to responses from a recent survey of students attending schools in the southern metropolitan area of Adelaide. This question asked students to indicate “which is most like you when you are at school?” The faces were scored from 1-7, where a high score indicated unhappiness.

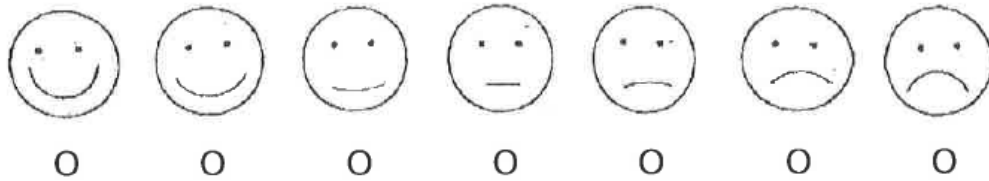

- **School Connectedness and Support** (8 items). Questions in this section were developed by the researchers based on research by Lee & Robbins (1995) and were included as a measure of students’ sense of belonging at school and perceived school support. The items were on a 7-point Likert Scale ranging from “very strongly disagree” to “very strongly agree”. These questions were included in an assessment of school satisfaction of IB MYP students.
- **Questions about bullying.** The Peer Relations Scale (PRQ) developed by Rigby and Slee (1991) was included as a measure of being victimised, bullying others and pro-social behaviour. Students responded to these questions using a scale ranging from “never”, “once in a while”, “pretty often” to “very often”. Questions from the pro-social subscale were included in an assessment of student relationships, while the bully and victim subscales were included in an analysis investigating the relationship of cognitive and affective empathy with involvement in bullying.
- An indication of **how often students have been bullied.** This question asked students to indicate “How often this year have you been bullied or harassed by a student or students at school?” using a scale “every day”, “most days”, “one or two days a week”, “about once a week”, “less than once a week” and “never”. This question enabled the identification of students who had been bullied once a week or more often (i.e. seriously bullied).
- A question to determine **how safe they feel from being bullied** at school. Students were asked to respond to the question “How safe do you feel from being bullied or harassed at this school?” by selecting a response of “not at all safe”, “only safe sometimes”, “usually safe” or “always or nearly always safe”.
- **The Flourishing Scale** (Diener et al., 2009). This scale is a summary measure of a person’s self-perceived success in important areas such as engagement, relationships, optimism, self-esteem, meaning and purpose. The scale provides an indication of whether one is psychologically

flourishing (presence of good mental health). This uni-dimensional scale provided a single score that was an indication of students' general psychological well-being. The items were on a 7-point Likert Scale ranging from "very strongly disagree" to "very strongly agree".

- **Social, emotional, and psychological well-being** from the Mental Health Continuum Scale (Keyes, 2006). Using different aspects of three dimensions of well-being (social, emotional and psychological well-being) this scale provides an indication of whether a person is flourishing, languishing or has moderate mental health. Students were asked to respond to questions about how often in the past month they experienced hedonic and eudaimonic feelings using the scale of "never", "once or twice", "about once a week", "2 or 3 times a week", "almost every day" and "every day".
- A measure of **emotional and psychological well-being** using the Stirling Children's Well-being Scale (Liddle & Carter, 2010). This scale provides an overall measure of positive outlook and a positive emotional state. Students responded to questions about how they had been thinking and feeling "over the past couple of weeks" with scale items of "never", "not much of the time", "some of the time", "quite a lot of the time", and "all of the time".
- Garton and Gringart's (2005) **Empathy Scale** for young Australian children. This scale measures cognitive and affective empathy in children aged 6 and older. In our study it provided an indication of IB MYP students' level of 'caring'. Students responded to items that described cognitive and affective empathy by selecting how statements best represented them i.e. "not like me at all", "hardly ever like me", "occasionally like me", "fairly like me" or "very like me".
- The Marsh (1990) **Global Self-concept Scale**, which measures the amount of time youth feel good about themselves: "never", "rarely", "sometimes", "most of the time" or "always".
- **Engagement in Self-Reflection** (6 items) from the Self-Reflection and Insight Scale (SRIS; Grant et al., 2002), developed in Australia. Only the self-reflection part of this scale was used as a measure of how strongly students agreed with statements about being reflective. Students responded using a 6-point Likert scale ranging from "very strongly disagree" to "very strongly agree".
- **The Connor–Davidson Resilience Scale** (CD-RISC; Connor & Davidson 2003). The CD-RISC provides an indication of the state of resilience of IB students. This scale was purchased from the authors and comparative international statistics are available for comparison ([www.connordavidson-resiliencescale.com/](http://www.connordavidson-resiliencescale.com/)). Students were asked to respond to the CD-RISC items

by considering how each statement applied to them “over the last month”, using responses “not true at all”, “rarely true”, “sometimes true”, “often true”, and “true nearly all the time”.

- Questions to assess **mental ill-health** using the Strengths and Difficulties Questionnaire (SDQ) (Goodman, 2005). The SDQ is a screening instrument for mental ill-health (Goodman, 1997) that includes subscale measures of emotional symptoms, conduct problems, hyperactivity, peer problems and pro-social behaviour (this final subscale is not included in the total ill-health score). The items were on a 3-point scale ranging from “not true”, “somewhat true” to “certainly true”. Findings from this measure were compared to Australian normative data for 11-17 year olds (Mellor, 2005).
- **Student demographics** including Year level, age, gender, home postcode and whether a student had special needs. These variables were used as covariates and for comparisons between groups
- The final question in the questionnaire was an open-ended question asking students to provide information about how they thought their **school helped them to become successful**: “Describe with words or with a drawing how your school helps you to be successful”.

## Interviews and Focus Groups

To enhance opportunities for the expression of staff and student voices our study also included interviews and focus groups.

Interviews with key MYP staff about school practices for success, well-being and the explicit development of the IB Learner Profile, formed part of the qualitative study. Semi-structured interviews and focus groups were undertaken with staff (including principals) and five groups of students at the schools that participated in the survey in order to address the research questions of:

- What are the key success practices and supports for promoting positive social-emotional development undertaken by schools?
- To what extent do schools align their practices to support student social-emotional development with the attributes of the IB Learner Profile?

In the interviews and focus groups staff and students were asked to consider values, philosophies and practices undertaken in the school that impacted on student learning and well-being, and whether they would assess these approaches as successful.

## Staff

At each school the researchers met with at least two key MYP staff whose role was defined as the MYP coordinator, the well-being coordinator, the school counsellor, head of middle school or principal. The interview discussions focussed on school success practices, including any specific programmes which were being implemented to enhance student well-being. Questions about facilitating the development of some Learner Profile attributes, such as empathy, reflection and global self-concept, were also discussed. The discussion questions during the 50-minute semi-structured interview sessions with staff included:

- What sorts of programmes do you have in place to assist students with their well-being?
- What sorts of practices do you use to help students become successful?
- How would you define student success?
- How does your perception of student success link with well-being?
- How effective do you think your practices are for facilitating student success?
- How important are relationships for student well-being?
- What do you think are the barriers and enablers of success?
- What things do you do to develop the IB Learner Profile in students?
  - To assist students develop empathy?
  - To assist them to be reflective?
  - To ensure there is balance in their lives?

## Students

A similar approach was used with students, except that students were questioned together in focus-groups rather than individual interviews. Questions in the focus groups were semi-structured and were designed to “relax” individuals in the first instance and to encourage them to offer their thoughts and opinions. Other questions were used to obtain the perspective of students about school success practices and support with their well-being. In the focus groups students were instructed:

*We would like to know what school is like for students of your age and whether you think your needs are being met. We would like to reassure you that anything that is said during this session is strictly confidential. Once the recording has been transcribed it will be erased. In our reporting participants will be referred to as female/male student 1 or 2 etc. from school A or B etc. So no one will know who said what from what school. We are really interested in your thoughts and opinions, and there are no right or wrong answers.*

*What you have to say is important to us. What you tell us will help us to better understand the kinds of things that assist student well-being so that there can be better planning for this in the future.*

The semi-structured discussion questions included:

- What is the best part of coming to school?
- Would you say that there is at least one teacher at school that you could go to if you had a problem?
- How important do you think it is for students to set learning goals for themselves?
- How would you define student success?
- Can you think of any ways that the school helps students become successful?
- How important are relationships for student well-being?
- What things does the school do to develop the IB Learner Profile in students?
  - To assist students develop empathy?
  - To assist them to be reflective?
  - To ensure there is balance in their lives?

Following ethics approval, data collection began in schools in September 2013. The WBQ was administered by school staff to students. Generally, schools conducted the questionnaire during one 40-minute lesson under test-like conditions supervised by class teachers. Interviews and focus groups were generally organised on the same day, although at some schools researchers returned to undertake this part of the study. Staff made themselves available during a free lesson to be interviewed, while student focus groups were organized in 30-45 minute blocks before and, or after questionnaire administration. The study did not require participants to remain at school after normal school hours.

## Sampling

Purposive sampling was an objective of our study. This ensured diversity in the types of schools and students represented by the data and accorded with Teddlie and Yu's (2007) approach for achieving representativeness or comparability in non-probabilistic sampling used in mixed method research. By including a wide array of schools in the sampling the aggregated responses of participants are more likely to be close to that of the whole IB MYP population in South Australia, and since there is no reason to determine that IB MYP in SA differs from other parts of the country, to that of other Australian states as well.

The sampling strategy involved the selection of at least one school from each of the educational jurisdictions as well as schools servicing high, medium and low socio-economic families. It was essential to include

participants that range in socio-economic status in order to account for confounding socio-economic effects on schooling and well-being (Bradley & Corwyn, 2002).

## School Sample

Twelve IB MYP schools were approached to participate in our study and two Catholic, three government and three independent schools agreed to participate (see Table 2). The eight schools participating in the study represented half of all IB MYP secondary schools in South Australia and included an all-girls (Catholic) school and an all-boys (Independent) school. One of the schools was a candidate school that has maintained this status for a number of years.

**Table 2** Types of schools participating in the study

School	SES	location	Type	DECD Disadvantage Category*	
1. School A	Low SES	Government	Birth – Year 12	coeducational	2
2. School B	Low SES	Government	Year 8 – Year 12	coeducational	3
3. School C	Medium SES	Government	Year 8 – Year 13	coeducational	6
4. School D	High SES	Independent	Reception – Year 12	all boys	NA
5. School E	High SES	Catholic	Reception – Year 12	coeducational	NA
6. School F	High SES	Catholic	Reception – Year 12	all girls	NA
7. School G	High SES	Independent	Year 7 – Year 12	coeducational	NA
8. School H	Medium SES	Independent	Reception – Year 12	coeducational	NA

\*low number indicates high disadvantage

As shown in Figure 3, one quarter (25.0%) of the sampled students were from a SA government school (Schools A-C), 29.2% from a Catholic school (Schools E and F) and the remainder (45.7%) were students attending an Independent school (Schools D, G and H).

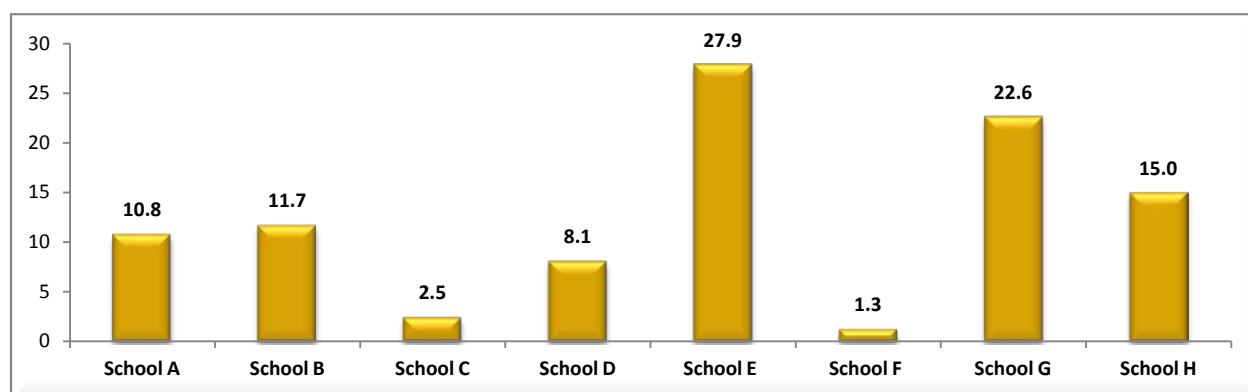

**Figure 3** Proportion of student participants from each school

## Response Rates

All IB MYP students (n=3,478) in the eight schools were invited to participate in the study and just over half (56.7%) filled-in the WBQ. Schools chose an “opt out” or “opt in” approach for student involvement in the quantitative study, provided parents were fully informed about the project. Most of the schools decided for an “opt out” approach for parental consent. In these cases details about the study were provided to parents and students, and a request was made that they notify the school if they did not wish to participate. Three schools chose the “opt in” approach where information about the study and a consent form was sent home to parents via students. This method required a signed consent form for participation in the quantitative study. The outcome of the “opt out” was high response rates which were close to 90% in some schools, while the “opt in” approach resulted in much lower response rates, such as 6.1% at one school (see Table 3).

**Table 3** Response rates from participating schools

	Number	Discarded	Sample Population	Response Rate
1. School A	214	8	240	89.2
2. School B	232	12	360	64.4
3. School C	49	0	800	6.1
4. School D	157	0	400	39.3
5. School E	543	3	608	89.3
6. School F	26	0	120	21.7
7. School G	453	18	600	75.5
8. School H	297	6	350	84.9

**Table 4** Number of male and female participants from each school

School	Male		Female		Total	
	number	percent	number	percent	number	percent
1. School A	87	44.4	109	55.6	196	100.0
2. School B	107	50.7	104	49.3	211	100.0
3. School C	20	40.8	29	59.2	49	100.0
4. School D	156	100.0	-	-	156	100.0
5. School E	275	51.8	256	48.2	531	100.0
6. School F	-	-	26	100.0	26	100.0
7. School G	224	53.1	198	46.9	422	100.0
8. School H	144	50.3	142	49.7	286	100.0
<b>Total</b>	1013	54.0	864	46.0	1877	100.0
						Missing (gender) =58 (3.0%)

## Student Focus Groups

Participation in the student focus groups was determined by school staff, who selected students and collected parental consent for participation. Students from five of the study schools (schools A, C, D, E and H) were involved in 10 focus groups. Focus group participants were from years 6 to 10 and ranged in age from 11 to 15. The number of males (n=25) and females (n=24) in the focus groups was almost equal. Focus groups were held in a private area on the school campus and in three of the focus groups a staff member was present.

## Staff Interviews

Thirteen school staff comprising six males and seven females participated in the interviews. The participants included principals, counsellors, IB MYP co-ordinators, heads of middle-school and well-being coordinators<sup>3</sup>.

## Survey Sample

Nearly 2,000 (n=1983) IB MYP students participated in the quantitative study by completing the WBQ. Of these 53 (2.7%) were discarded after scanning because they had not been completed appropriately (e.g. social desirable responding; circling the same response for all questions) or had more than 50% of missing responses. The sample of IB MYP students whose data was included in this analysis numbered 1930. Most (90.7%) of the IB MYP students did not have special needs.

### *Gender*

There were significantly more males than females in the sample ( $\chi^2(1) = 12.0, p < .001$ ).

As Figure 4 illustrates, 54% of the sample were males.

### *Year Level*

There were more students from junior secondary school (Years 8, 9 & 10) than other Years. This is shown in Table 5 and Figure 5, where it is evident that nearly one third (31.2%) of the student sample were Year 8s and about one quarter (26.3%) were Year 9s.

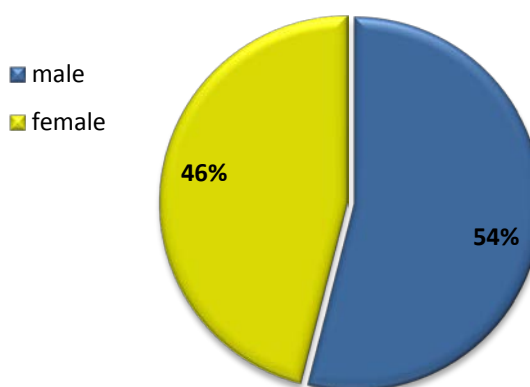

Figure 4 Gender of study participants

---

<sup>3</sup> Numbers not provided in order to protect the identity of participants where there was only one person from a particular group



**Table 5 Gender and year level of study participants**

School	Year 6		Year 7		Year 8		Year 9		Year 10		Total	
	no.	%	no.	%	no.	%	no.	%	no.	%	no.	%
1. School A	41	20.2	22	10.8	77	37.9	63	31.0	0	0	203	100.0
2. School B	0	0	0	0	71	33.8	62	29.5	77	36.7	210	100.0
3. School C	0	0	0	0	23	46.9	21	42.9	5	10.2	49	100.0
4. School D	0	0	43	28.1	39	25.5	47	30.7	24	15.7	153	100.0
5. School E	76	14.4	77	14.6	125	23.7	120	22.7	130	24.6	528	100.0
6. School F	0	0	0	0	26	100	0	0	0	0	26	100.0
7. School G	0	0	86	20.0	130	30.3	91	21.2	122	28.4	429	100.0
8. School H	40	14.0	57	19.9	98	34.3	91	31.8	0	0	286	100.0
<b>Total</b>	<b>157</b>	<b>8.4</b>	<b>285</b>	<b>15.1</b>	<b>589</b>	<b>31.2</b>	<b>495</b>	<b>26.3</b>	<b>358</b>	<b>19.0</b>	<b>1884</b>	<b>100.0</b>
Missing = 46 (2.4%)												

As Figure 5 shows, the data was skewed with more students in the older Years (8, 9 and 10) of the IB MYP.

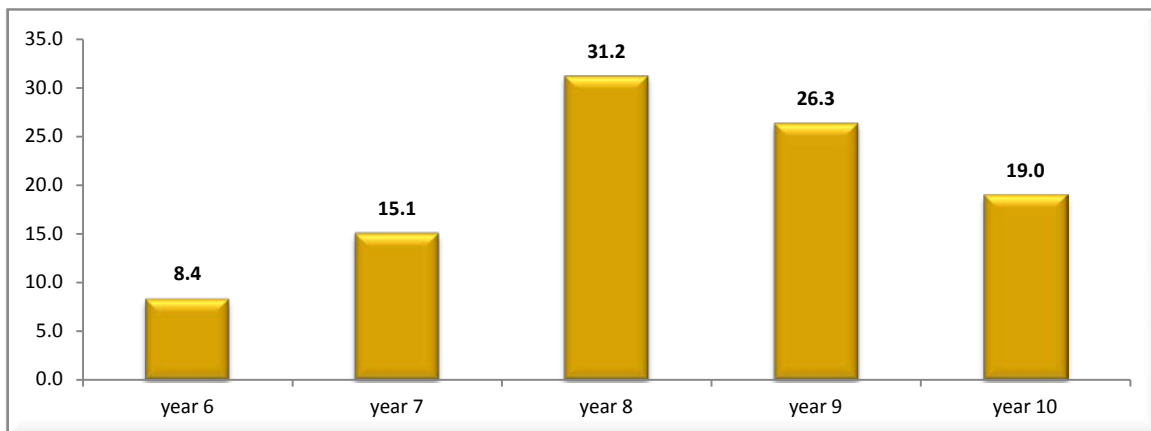

**Figure 5 Proportion of student participants in each year level**

## Age

The age distribution of students is represented in Figure 6, which shows that only 14.7% of participants were under 13 years of age, while 10.2% were over 15. Three quarters (75.1%) of the sample were aged 13-15 years. The average age of participants was 13.9 years (S.D. = 1.3).

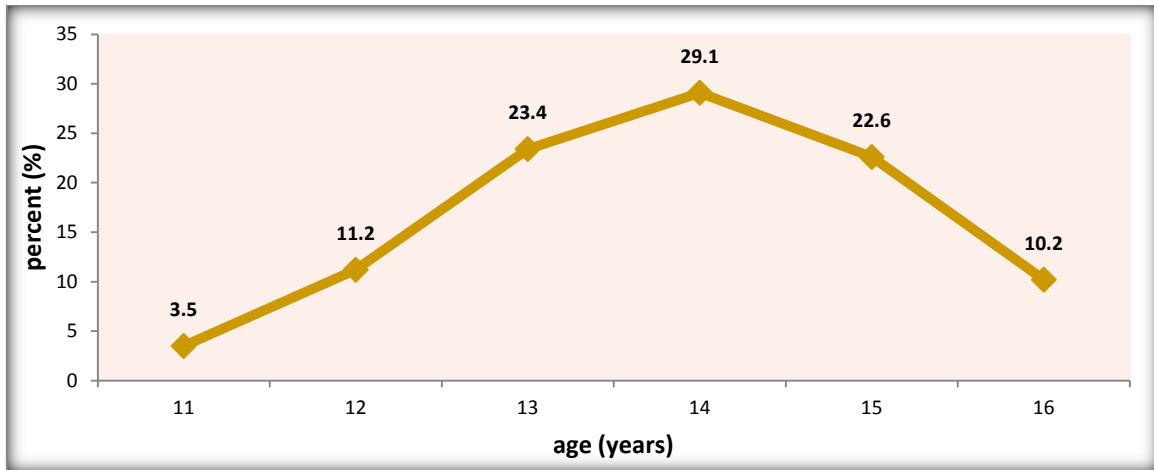

Figure 6 Mean age of study participants in each year level

### *Socio-Economic (SES) Background*

While students in government schools are likely to live in their local area, students attending independent schools may come from a range of suburbs spread across the Adelaide metropolitan area, and if they are live-in boarders, from SA country areas or overseas. The Socio-Economic Indexes for Areas (SEIFA) produced by the Australian Bureau of Statistics (ABS, 2008) provides an estimation of the socio-economic background of participants. According to government policy makers in the Department of Education, Employment and Workplace Relations (DEEWR), the SEIFA index, while not perfect, is currently the best measure of socio-economic background available in Australia (personal communication, 2013).

The SEIFA index is determined from census data and comprises four indexes that measure different aspects of socio-economic conditions by geographic areas (ABS, 2008). Each SEIFA index is created using a series of different variables and aims to capture a slightly different aspect of relative disadvantage. Because of this it is possible for the same area to be ranked differently on each index.

The Index of Economic Resources (IER) does not contain any education or occupation measures but focuses on Census variables including household income, housing expenditure and household assets, while the Index of Education and Occupation (IEO) attends to community educational and occupational characteristics including the proportion of people with a higher qualification or with employment in skilled occupations. Another index that comprises the series is the Index of Relative Socio-economic Advantage and Disadvantage (IRSAD) which contains summary information about the economic and social resources of people and households within an area and includes both measures of relative advantage and disadvantage.

Another part of the SEIFA is the Index of Relative Socio Economic Disadvantage (IRSED), which reflects relative disadvantage derived from information such as low educational attainment, high unemployment and

the proportion working in relatively unskilled occupations found in a particular geographic area. This was the measure of disadvantage used in our study. The IRSED deciles were used as the control socio-economic (SES) background variable in our study.

The middle two-thirds of IRSED scores fall between 900 and 1100, with an average of 1000. Scores outside this range would be considered representative of high and low disadvantage, by Australian standards, although there is no particular score below which an area is classified as disadvantaged and above which it is classified as not disadvantaged. The percentages of the Australian population in these three SES categories of low, medium and high are 25%, 65% and 10%, respectively. The sample, as shown in Figure 7, did not match this distribution. Students from low SES were underrepresented and students from middle SES backgrounds were over-represented.

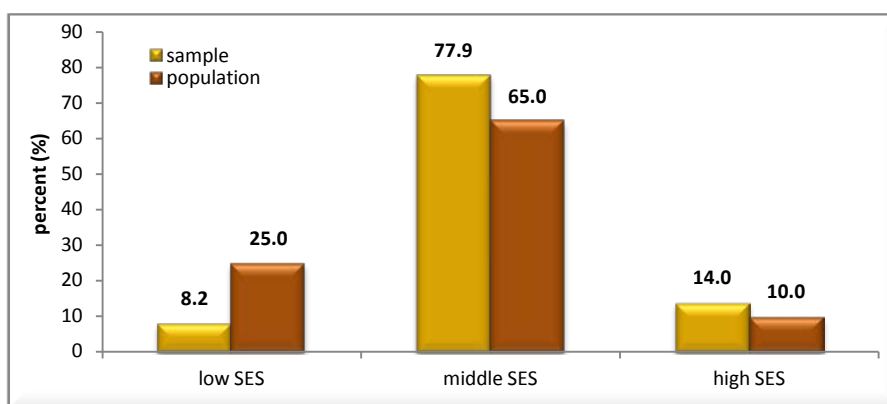

Figure 7 Socio-economic background of study sample compared to the Australian population

## Analysis of Data

Statistical methods, including parametric and non-parametric tests, using SPSS v22 and MPlus v7, were employed to analyse data collected from a survey of IB MYP students. Little's Missing Completely at Random (MCAR) test (Little, 1988) was performed to test the nature of missing data and the FIML (Full Information Maximum Likelihood) was used to deal with missing data in MPlus ((Muthén & Muthén, 2009). However, on all questionnaire items the amount of missing data was less than 5%, which according to Schafer (1999) is inconsequential. Nonparametric statistical tests that did not assume that the data was normally distributed were used to test for gender and other group differences. General linear models, controlling for socio-economic background and school, were used to test for interaction effects of gender and year level.

Effect size (E.S.) was calculated as a Pearson  $r$  correlation (Field, 2005) and interpreted according to Cohen (1992) as: low if the value of  $r$  varies around 0.1, medium if  $r$  varies around 0.3, and large if  $r$  varies more than 0.5. The strength of association between two variables measured using correlations ( $r$ ) is generally categorised as weak if  $0.1 < r < 0.29$ , moderate if  $0.3 < r < 0.69$ ; and strong if  $0.7 < r < 1.0$ . In chi-square tests the effect size was determined by Cramer's  $V$ , and interpreted the same way as  $r$  (Field, 2005). The effect size ( $r$ ) was only calculated for F-tests where there was one degree of freedom i.e. between two groups (Field, 2005).

Our study included an examination of latent variables. Raykov and Marcoulides (2006) have described latent variables as “hypothetically existing constructs” or factors, with the characteristic “that they cannot be measured directly, because they are not directly observable” (pp. 9-10). Only proxies for them are possible using specific instruments that are indicators of the construct. Mathematical ability and intelligence, are examples of latent variables that for measurement purposes, require a number of different observable (manifest) variables. The manifest variables generally typify the construct or factor of interest. A number of manifest variables are needed in order to obtain a complete picture of the construct so that the bias associated with a single variable is avoided. For example, the performance of students in algebra, trigonometry, calculus and geometry, could be indicators, or manifest variables, for mathematical ability.

Confirmatory Factor Analysis (CFA) procedures were used to test and calibrate the scales used for measuring well-being and other groups of variables contained in the WBQ. Latent variable scores were calculated using factor score coefficients derived from the CFA using the method described by Holmes-Smith and Rowe (1994) after model trimming (Kline, 2011). These are reported in Appendix B.

Structural Equation Modelling (SEM) was considered the best approach to use to examine the relationship between factors (e.g. resilience) and the well-being measures. Unlike traditional approaches, such as multiple linear regression, a valued feature of SEM is that it provides a more accurate picture of the relationships between variables, as it includes an explicit consideration of the measurement error in the observed variables (Raykov & Marcoulides, 2006) and the residual error, or disturbance, representing the unexplained or unmeasured causes of a dependent variable (Kline, 2011). In a normal multiple linear regression there is an assumption that all variables have been measured without error. This is of course not realistic and SEM takes the measurement error into account. The main advantage of SEM is that because the error variances can be estimated and removed, the relationships between factors can be examined free of error as only common variance remains (Ullman, 2007).

A SEM also comprises a measurement and a structural part. The part of a SEM that relates to how variables measure the constructs or factors is known as the “measurement model”, while the part of the SEM that shows the relationships between latent variables is called the “structural model” (Ullman, 2007). Some researchers (Anderson & Gerbing, 1988; Cohen, Cohen, Teresi, Marchi, & Velez, 1990) have recommended

that the measurement part of the model should be fixed, and identified separately, before testing the structural part of the model. This two-step approach, which allows the reliability of the measurement model to be checked and reported, was the process implemented in the SEMs undertaken in this research. Appendix B provides the fit indices of the measurement models “calibrated” for use in the regression models.

All of the analyses where MPlus was used involved the estimation method referred to as MLR (Robust Maximum Likelihood) where corrections for non-normality are made for parameter and standard error estimates (Muthén & Muthén, 2009). This estimation method employs algorithms that are robust to non-normal data.

Due to clustering, student survey responses were also not “independent”. This is because students were “nested” in SES, schools and year levels, so were more likely to be similar to other students in the same cluster, but different from students in other clusters. Such a commonality amongst participants cannot be ignored as statistically “non-independence” creates errors (Field, 2009; McClave et al., 2005; Tabachnick & Fidell, 2007). The effect of not taking non-independence into account is that the standard errors are underestimated and the outcome is an over-estimation of the significant effects (Asparouhov, 2005; Kline, 2011; Muthén & Muthén, 2009). It is possible in MPlus to take account of clustering or nesting amongst participants by using the “cluster” option with “type=complex” (Muthén & Muthén, 2009) and this was the method employed in our study. The “type=complex” option is an analysis which “computes standard errors and chi-square test of model fit, taking into account stratification, non-independence of observations, and/or unequal probability of selection” (Muthén & Muthén, 2009, p. 477).

A chi-square ( $\chi^2$ ) statistical test was undertaken to test how well the proposed model fits the actual data, i.e., to test the “absolute fit” of the model. A non-significant value of  $\chi^2$  indicates that the specified model fits the observed data (Hox & Bechger, 1998). A problem with  $\chi^2$  however, is that it is sensitive to sample size and it is not reliable with non-normally distributed data (Brown, 2006). For these reasons Brown (2006) suggested that “while  $\chi^2$  is routinely reported in CFA research, other fit indices are usually relied on more heavily in the evaluation of model fit” (p. 81).

While there are no exact cut-offs for model fit decisions (Kline, 2011), Brown (2006) suggested that “support for contentions of reasonably good fit ... is obtained in instances where (1) SRMR (Standardised Root Mean Square Residual) values are close to 0.08 or below; (2) RMSEA values are close to 0.06 or below; and (3) CFI and TLI values are close to 0.95 or greater” (p. 87). As a rule of thumb, Browne and Cudeck (1993) suggested that when considering RMSEA, values between 0.1 and 0.08 represent a “mediocre fit”, values less than 0.08 indicate an adequate model fit, values less than 0.05 suggests a good model fit, while values greater than or equal to 0.1 should be rejected. Kline (2011) supported a reporting of a set of fit indices including RMSEA, CFI, TLI and SRMR. He also suggested a consideration of the “close-fit hypothesis” and the “poor-fit

hypothesis”, which relate to the RMSEA 90% confidence interval. The “close-fit hypothesis” is not rejected if the lower limit for RMSEA is less than or equal to 0.05, while the “poor-fit hypothesis” is not rejected if the upper limit for RMSEA is greater than or equal to 0.1. This was the procedure that was used to test model fit in our study.

Score reliability was computed for each of the measuring instruments using Hancock and Mueller’s (2001) “Coefficient H”. This coefficient is considered to be a better measure of reliability than Cronbach’s alpha, as in congeneric models alpha represents the lower bound of the true estimate of reliability (Brunner & Heinz-Martin, 2005; Holmes-Smith & Rowe, 1994). In contrast, the algorithm used to calculate “H” recognises that not all indicators contribute equally to the construct or factor and it incorporates the weight of the scale indicators to calculate construct reliability (Brunner & Heinz-Martin, 2005). Like Cronbach’s alpha, values of H above 0.70 suggest that a factor is reliable (Hancock & Mueller, 2001).

Findings reported in each chapter followed the same statistical procedures. Group differences (gender and year level) were examined using a General Linear Model (GLM), controlling for influencing factors such as socio-economic (SES) background and school, in SPSS, although gender and year level findings are reported separately in each chapter. The GLM method is commonly used to examine group differences in the research literature (Field, 2009). The quantitative data was then examined using more robust methods in MPlus, which accounted for the nested-ness, non-normal and non-randomness of the data. This included the use of Multiple Indicators Multiple Causes (MIMIC) models and Structural Equation Modelling (SEM). Relationships between factors and constructs were examined using SEM in MPlus, after the measurement models had been calibrated.

Analysis of the qualitative data was undertaken in NVivo 10, following the transcription of the audio-tapes. The transcripts were imported into NVivo where they were thematically analysed.



# Psychological Flourishing

---

*Whereas subjective well-being is defined as people's evaluations of their lives, psychological well-being is thought to represent optimal human functioning (Diener et al., 2009, p. 251).*

The first measure of IB MYP student well-being, reported in this chapter, is that of flourishing. A combination of functioning effectively and feeling good about oneself is considered flourishing (Diener et al., 2009). The Flourishing Scale, according to Diener et al. (2009), “provides a good assessment of overall self-reported psychological well-being” (p. 260). The Flourishing Scale seeks to assess psychological well-being with single items that tap into relevant dimensions of well-being identified as important in the literature by researchers such as Ryff, Seligman, Csikszentmihalyi, Maslow, Deci and Ryan. This scale was originally titled “psychological well-being” because the focus of the scale is on items that reflect a person’s self-perception of functioning. The eight item scale measures socio-psychological prosperity (i.e. flourishing). The included items cover meaning and purpose, supportive and rewarding relationships, engagement and interest, contributing to the well-being of others, competency, self-acceptance, optimism and being respected. In accordance with a positive psychology approach, all items are positively phrased.

The Flourishing Scale has been found to be well correlated with other psychological well-being scales, such as the Scale of Positive and Negative Experience (SPANE, Diener et al., 2010) and it has good psychometric properties (Silva & Caetano, 2013). The scale has been validated with a Portuguese sample by Silva and Caetano (2013).

The Flourishing Scale was used to provide an indication of how well IB MYP students were flourishing. To distinguish this measure of flourishing from the one devised by Keyes (2006) as part of the Mental Health Continuum (MentHC), scores obtained from Diener et al.’s Flourishing Scale are referred to in our study as psychological flourishing and the acronym FloS (i.e. Flourishing Scale) is used.

## Psychological Flourishing: Measurement

The degree that IB MYP students were psychologically flourishing was indicated by scores calculated from the Flourishing Scale. High FloS scores indicate that respondents view themselves in very positive terms in diverse areas of positive functioning across domains considered important for well-being. Researchers (Diener et al., 2009; Huppert, 2009) suggest that individuals who are flourishing are effective learners, productive workers, are likely to make contributions to their communities, have good social relationships, and better health and life expectancy.



## Psychological Flourishing: FloS Total Scores

The eight items from the Flourishing Scale were summed (following Diener et al.'s method) to obtain a total FloS score for each student. FloS scores ranged from 8 to 56. High FloS scores represent persons “with many psychological resources and strengths” (Diener et al., 2010, p. 155). The mean FloS score for all IB MYP students in the sample was 41.6 (S.D. = 8.1) and the median was 42.

While Diener et al. do not stipulate any cut-off values to indicate “flourishing”, a person that selected “agree” for each item would have a total FloS score of 40. We determined that a score above this cut-off would be a good indicator of flourishing. As shown in Figure 8, just over half (55.3%) of the participants had a FloS score of 41 or higher. This would suggest that just over half of the IB MYP students in the sample had good psychological resources and strengths, and therefore were flourishing.

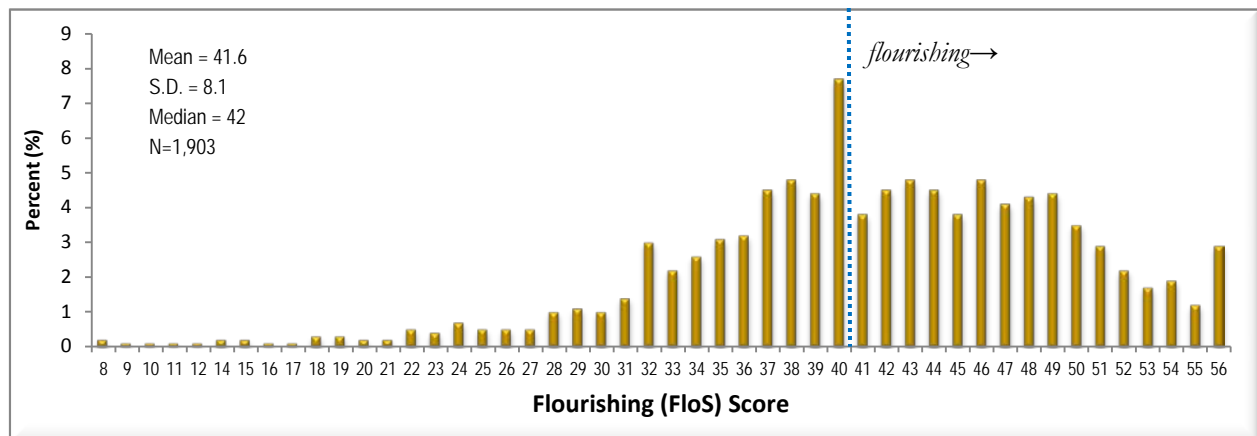

Figure 8 Flourishing (FloS) scores of IB MYP student participants

### Psychological Flourishing (FloS) by Gender and Year Level

The total FloS scores of males and females were compared. As evident from Figure 9, males were more likely than females to have high FloS scores (Mann-Whitney U-Test,  $Z = -3.9$ ,  $p < .000$ ,  $E.S.(r) = 0.09$ ). Using the (arbitrary) cut-off of 41, more males than females were classified as flourishing i.e. 59.8% vs 50.9%

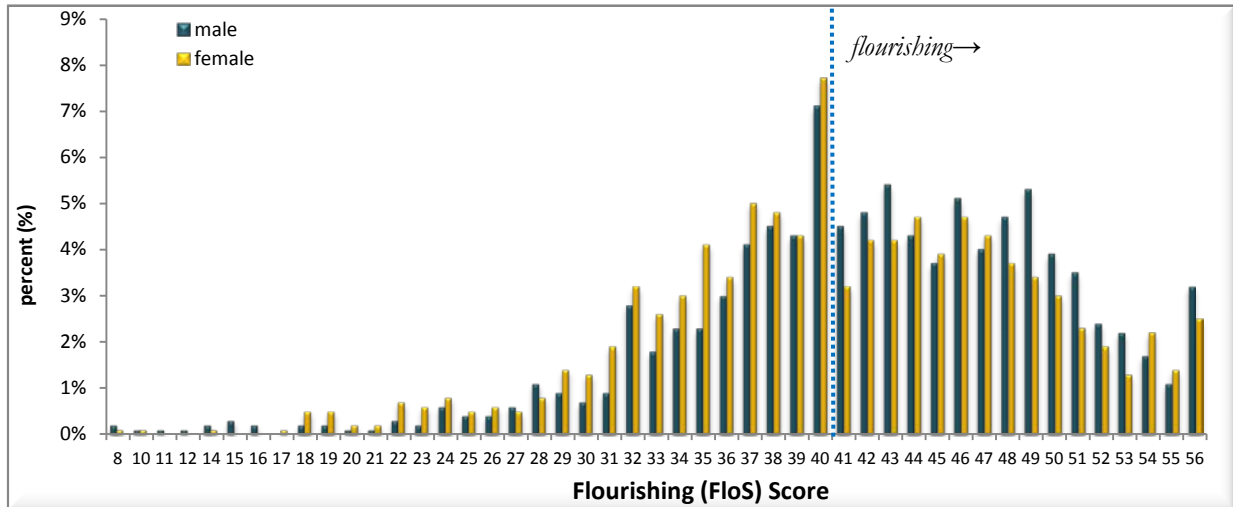

Figure 9 Flourishing (FloS) scores of male and female IB MYP student participants

IB MYP males were more likely to be psychologically flourishing than females. The gender difference was consistent ( $F(1) = 12.2, p < .000, E.S.(r) = 0.08$ ) even when controlling for SES (which was significantly associated with FloS scores:  $F(1) = 25.6, p < .000$ ) and school (which was not significantly associated with FloS scores:  $F(1) = 1.7, p > .05; E.S.(r) = 0.08$ ). As shown in Figure 10, the median FloS score for males was 43, while for females it was 41. However, the effect size of the male and female difference was small.

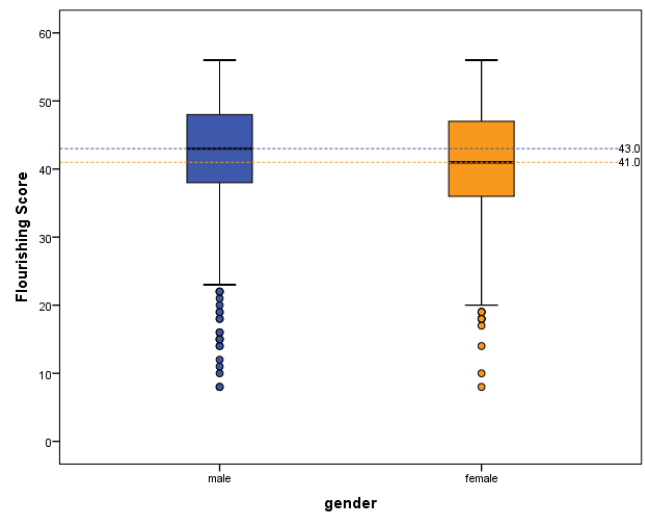

Figure 10 Distribution of flourishing (FloS) scores of males and females

Controlling for gender, SES and school, mean FloS scores were found to decrease with age, but appeared to remain steady from 14 to 16 years of age ( $F(5) = 7.1, p < .000$ ). As shown in Figure 11, the mean FloS scores remained in the flourishing range across all ages, except 16 years of age where it was just below our flourishing (FloS) cut-off score.

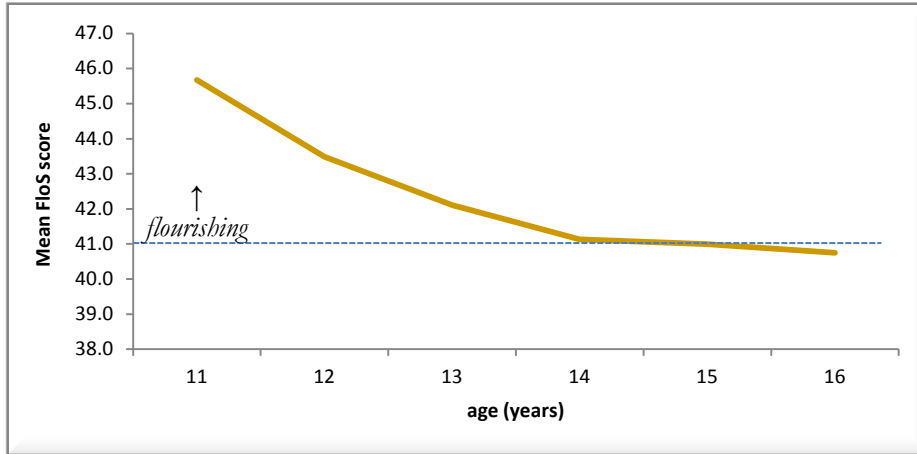

Figure 11 Mean Flourishing (FloS) scores by age

There was an interaction effect of age and gender ( $F(5) = 4.6, p < .001$ ) and of age and year level ( $F(4) = 4.1, p < .003$ ). Generally, females were more likely to have lower FloS scores with increasing age (see Figure 12) and females in the upper years of MYP had lower FloS scores than females in the lower years of MYP (see Figure 13).

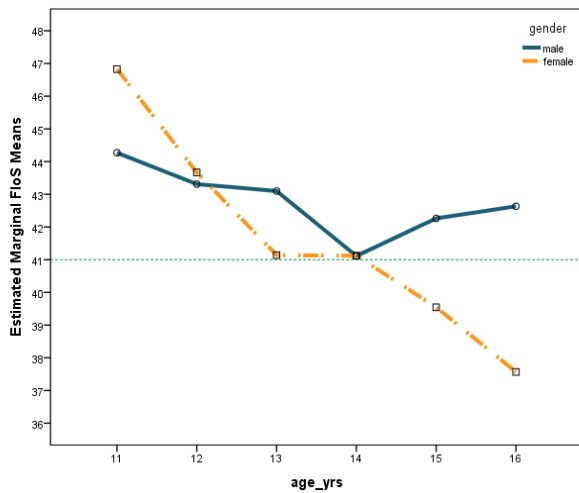

Figure 12 Mean flourishing (FloS) scores by age and gender

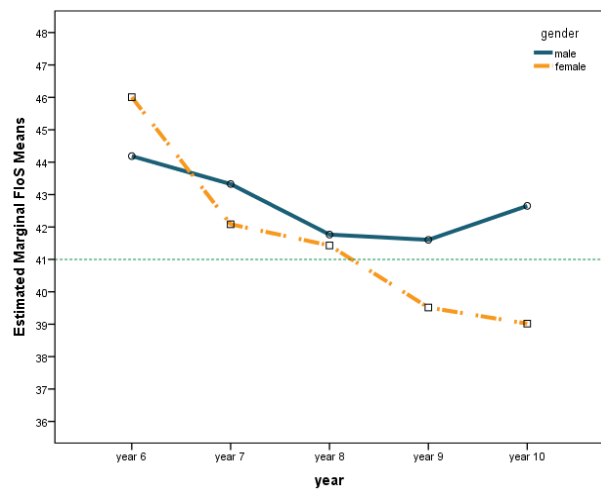

Figure 13 Mean flourishing (FloS) scores by age and year level

## Psychological Flourishing (FloS) by Socio-Economic (SES) Background

The FloS scores of students from different SES were also examined. Students from High SES were more likely to have high FloS scores compared to students from low SES who were more likely to have low FloS scores ( $F(2) = 6.1, p < .01, E.S.(r) = 0.06$  - see Figure 14).

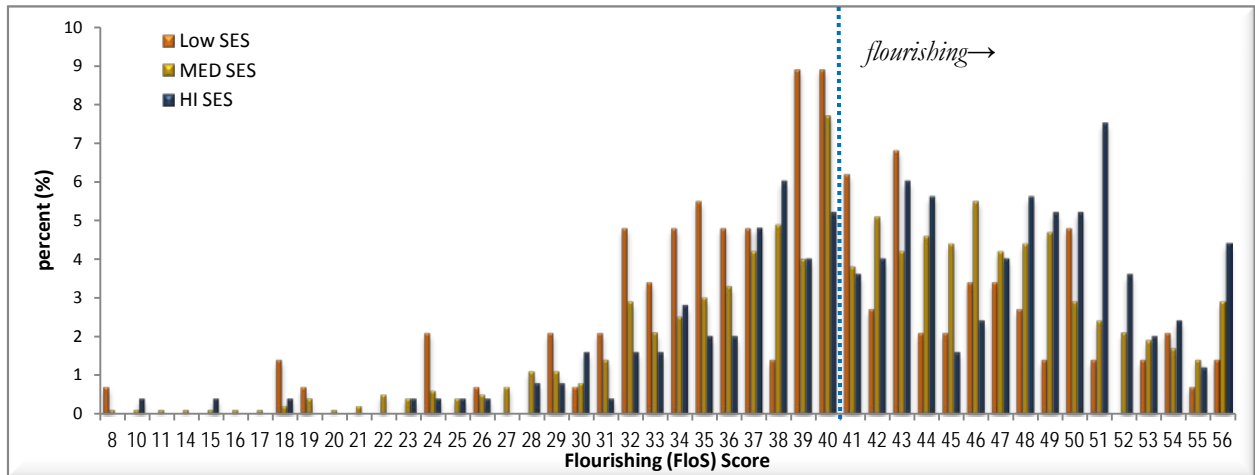

Figure 14 Flourishing (FloS) scores by socio-economic (SES) background

## The Flourishing Scale Model

The structure of the Flourishing Scale was examined in MPlus and a confirmatory factor analysis found that it was an adequate fit, although it was improved by dropping one item – “*I contribute to the happiness and well-being of others*”. While this item represents an important aspect of well-being, it was understandable that young people found it difficult to interpret its meaning. For example, it may be difficult for a teenager to know if he or she is contributing to the happiness and well-being of others during the developmental stages inherent in the middle years where there is a focus on developing one’s identity and autonomy, and where arguments with family members are not uncommon (Newman & Newman, 2012).

The new 7-item model was a good fit with the data (see Appendix B Figure 1) and it had good reliability (Coeff. H = 0.91). This was the model used in subsequent regression analyses involving measures of Flourishing (i.e. FloS) in our study.

Factors, such as gender, year level, age and socio-economic background, considered to be possible influences on the likelihood of flourishing, were also tested in MPlus using a Multiple Indicator-Multiple Cause (MIMIC – Wang & Wang, 2012) model (which provides a better account for error and for non-normal data, than the analyses above), using school as the clustering variable. The results (see Appendix B Figure 2), indicated there

was a significant influence of socioeconomic background (using the ISRED measure) on the likelihood that a student would be flourishing ( $p < .05$ ) – the less disadvantaged students were more likely to have higher FloS scores. A significant interaction effect of gender and year level on the likelihood of flourishing was also found ( $p < .000$ ), although there was no significant influence of age ( $p > .05$ ). Females in the upper years of MYP were less likely to be psychologically flourishing than males and females in the lower years of MYP. However, the low regression coefficients suggested that these elements were only small in influence. Together, gender, year level and SES accounted for only 6.4% of the variation in the FloS scores. This suggests that the presence of other factors that influence the likelihood of students flourishing independent of their gender, year level or socio-economic background, as well as the school they attended.

## Comparison with Other Students

A study of South Australian students by Venning et al. (2012), which used a variety of scales to determine the well-being of 13-17 year olds, found that 42% of the 3,913 adolescents sampled in 2007 were flourishing in life. While this proportion is lower than that determined from our study (55.3%) Venning et al. (2012) also found that “the prevalence of flourishing was lower in older adolescents” (p. 303). Given that Venning et al.’s sample included 17 year olds (9.8%) but no 11 and 12 year olds, a lower level of flourishing would be expected in their study. Therefore, a comparison between the proportion of IB MYP students who were flourishing with the proportion of SA students identified by Venning et al. as flourishing would not be well-founded.

College (University) students sampled by Diener et al. (2010) appear to have been flourishing more positively than the current IB MYP student sample. The higher percentile scores shown in Table 6, indicated that Diener et al.’s students generally scored higher than the IB MYP students in this sample.

As seen in Table 6, the 53 percentile indicated that 53% of Diener et al.’s students had a FloS score of 46 or less compared with a score of 43 or less for 53% of IB MYP students. However, Diener et al.’s students were tertiary students attending college, and since the Flourishing Scale was found to be most strongly associated with competence/mastery (Diener et al., 2010) higher flourishing scores would be expected. This is because college students as high school graduates would have already achieved a certain level of competency.

**Table 6** Percentiles of IB MYP students and college students

Percentile	IB MYP Student FloS Score	Diener et al.'s College Student FloS Score
1	18	25
3	24	29
5	28	32
7	30	34
10	32	36
13	33	37
15	34	38
18	35	39
21	36	40
24	37	41
28	38	42
33	39	43
39	40	44
44	40	45
53	43	46
60	44	47
70	46	48
77	48	49
83	49	50
87	50	51
90	51	52
93	53	53
96	55	54
98	56	55
100	56	56

## Discussion

The results suggest that nearly two thirds of the IB MYP students were flourishing using the Flourishing Scale measure. Although the median scores for both females and males were in the “flourishing range” (since the medians were FloS scores of 41 or more), there was an indication that some females, particularly those in the upper years of MYP were not flourishing as much as the males. The findings suggest that males were more likely than females to feel competent, masterful and to be functioning optimally. To ensure that this finding was not due to the oversampling of males, a re-analysis of the data which removed the sample of males from the all boys school found that the result was the same, so the oversampling of males was not associated with this finding.

Gender differences of this kind are not an uncommon finding in mental health and well-being studies. There is tentative emerging evidence that adolescent females nationally and internationally are reporting more mental health problems than boys. For example, research by Green, McGinnity, Meltzer, Ford and Goodman (2005) of 11 to 15 year olds in the UK found emotional disorders were higher in girls (4.1%) than boys (3%), while a more recent study of the status of girls in Indiana, USA by Kuter & Deom (2013) reported that daily feelings of sadness or hopelessness were more likely to have been conveyed by females than males. The Indiana study also found that the percentages of girls reporting this disposition increased from grade six to grade eight or nine and then decreased.

In a similar vein, students in the lower years of the IB MYP were more likely to be flourishing than students in the upper years of IB MYP. Possible reasons for this difference (which had only a small effect size) would be speculative.

As previously stated, Diener et al. (2009) suggested combining other scales of subjective well-being with the Flourishing Scale in order to obtain a better understanding of the multi-dimensional phenomenon of well-being. The next two chapters provide the findings from two other measures of well-being: the MentHC and StirCWB.

### *Subsequent Analyses*

In subsequent analyses students were clustered by SES, school and year level to statistically account for the influence of these variables on well-being scores. This approach enabled an analysis of other factors independent of these influences.

Furthermore, since age and year level were strongly correlated ( $r = 0.9$ ,  $p < .000$ ), only Year level was examined in subsequent analyses. It was thought that this would provide more relevant information to enable identification of Year level targets for future interventions or considerations.

# Mental Health Continuum

---

*... positive mental health [is] a combination of emotional well-being, psychological well-being, and social well-being.* (Howell, Keyes & Passmore, 2013, p. 60).

To obtain a better understanding of a person's well-being Diener et al. (2009) suggested that additional measures would be required. We determined Keyes's (2006) Mental Health Continuum Scale was considered a suitable instrument to use for this purpose since it incorporates a more complete model of mental health as well as providing another measure of flourishing.

Rather than mental health being the absence of mental disorders, Keyes (2002) has described a complete model of mental health, where flourishing is the presence of mental health and languishing is the absence of mental health. As such, in Keyes's view, mental health and mental disorder are separate states of functioning. Just as a mental disorder requires the fulfilment of several criteria, so too, argued Keyes (2006), the presence of mental health must satisfy a set of requirements. To be characterised as flourishing individuals must report at least half of the signs of mental health on a daily or almost daily basis.

Keyes (2006) developed the Mental Health Continuum Scale to determine whether an individual is flourishing, languishing or has moderate mental health. The scale comprises three subscales, namely social well-being, psychological well-being and emotional well-being. Keyes surmised that the emotional well-being scale provides a measure of hedonia, while the social and psychological subscales together provide a measure of eudaimonia or positive functioning. To be considered as flourishing an individual must report at least daily, or almost daily, one symptom of emotional well-being and at least six of positive functioning. This approach was used in our study to determine the extent that IB MYP students were flourishing, languishing or had moderate mental health.

“Languishing is a state that lacks positive functioning and has an emphasis on the individual merely existing from day to day” (Liddle & Carter, 2010, p.9). The same items on the MentHC are used to measure languishing, which comprises two parts: emotional well-being and positive functioning. Participants were considered to be languishing if their experiences of at least one of the three symptoms of emotional well-being and at least six of the eleven symptoms of positive functioning were not frequent i.e. they were experienced “once or twice” or “never”.

The 14-item (short form) of Mental Health Continuum Scale has been found to have good internal consistency ( $>.80$ ) as well as discriminant validity in adults (Keyes et al. 2008 ; Lamers, Westerhof, Bohlmeijer, ten Klooster, & Keyes, 2010) and adolescents aged 12–18 (Keyes, 2005).



## Mental Health Continuum: Well-being Measure

In our study, participants indicated how frequently during the past month they had experienced symptoms of emotional well-being, psychological well-being, and of social well-being by completing Keyes's (2006) Mental Health Continuum 14-item questionnaire that was incorporated into the WBQ.

Following Keyes's scoring method, students were classified as flourishing if they experienced at least one of the three symptoms of emotional well-being and at least six of the eleven symptoms of positive functioning "almost every day" or "every day". Participants were considered to be languishing if they experienced at least one of the three symptoms of emotional well-being and at least six of the eleven symptoms of positive functioning "once or twice" or "never". Students who were neither languishing nor flourishing were classified as moderately mentally healthy. Using this "minimum item" approach we found that nearly half (48.5%) of the IB MYP students in the study were classified as flourishing, a small proportion (8.0%) were considered to be languishing, while the remainder (43.5%) were considered to have moderate mental health.

A similar study by Keyes's (2006) of 1,234 American young people aged 12-18, found that 38% were flourishing, 6% were languishing and the remainder (56%) were moderately mentally healthy. When the eleven year olds from our study were removed to enable a better comparison with Keyes's sample, 47.9% of the 12-16 year old students were classified as flourishing, 8.2% as languishing and 43.9% had moderate mental health. While moderate mental health was most prevalent in Keyes's American sample of youth, flourishing was more common amongst the IB MYP students. This would suggest that IB MYP students were faring better than students in Keyes's (2006) sample. However, the presence of older high school adolescents in Keyes's sample may mean that a comparison between the two groups is not justifiable, so this comparison must be accepted with caution.

### *The Mental Health Continuum (MentHC) Model*

Further analysis of the MentHC involved a Confirmatory Factor Analysis (CFA), which was undertaken to investigate the MentHC model in our study. The original model proposed by Keyes (2006) was an adequate fit ( $\chi^2 (74) = 792.1, p < .000$ ; RMSEA = 0.072, 90% C.I.: 0.068 – 0.077, probability RMSEA  $\leq .05 = 0\%$ ; CFI = 0.941; TLI = 0.928; SRMR = 0.035). However, following trimming (see Appendix B Figure 3), the model was a very good fit with our data ( $\chi^2 (31) = 142.3, p < .000$ ; RMSEA = 0.044, 90% C.I.: 0.037 – 0.051, probability RMSEA  $\leq .05 = 90.5\%$ ; CFI = 0.986; TLI = 0.979; SRMR = 0.018). The well fitting model was used in subsequent SEM analyses to investigate the relationship of well-being with other variables in our study.

## MentHC: Well-being Composite Measure

An overall student well-being score (a latent variable comprised of a number of MentHC questionnaire items) was calculated using the factor score coefficients derived from the MentHC measurement model (see Appendix B Figure 3). These scores were then standardised so each student received a (rounded) score that matched the scale of “never”, “once or twice”, “about once a week”, “2 or 3 times a week”, “almost every day” or “every day”. This score was then used to determine whether a student was flourishing, languishing or had moderate mental health.

### Flourishing

As shown in Figure 15, our analysis suggested that just over half (54.1%) of the IB MYP students had a sense of well-being “almost every day” or “every day” and were therefore flourishing. This proportion accords with the number found to be flourishing using Diener et al.’s FloS, which was 55.3%.

### Languishing

Using this composite measure, overall 6.1% of IB MYP students were considered to have been languishing as their experience of well-being was “never” or “once or twice” during the past month, as shown in Figure 15.

### Moderate Mental Health

Not having been categorised as languishing or flourishing and reporting that their experience of well-being was “about once a week” or “2 or 3 times a week”, nearly two in five (39.7%) IB MYP students were found to have moderate mental health (see Figure 15).

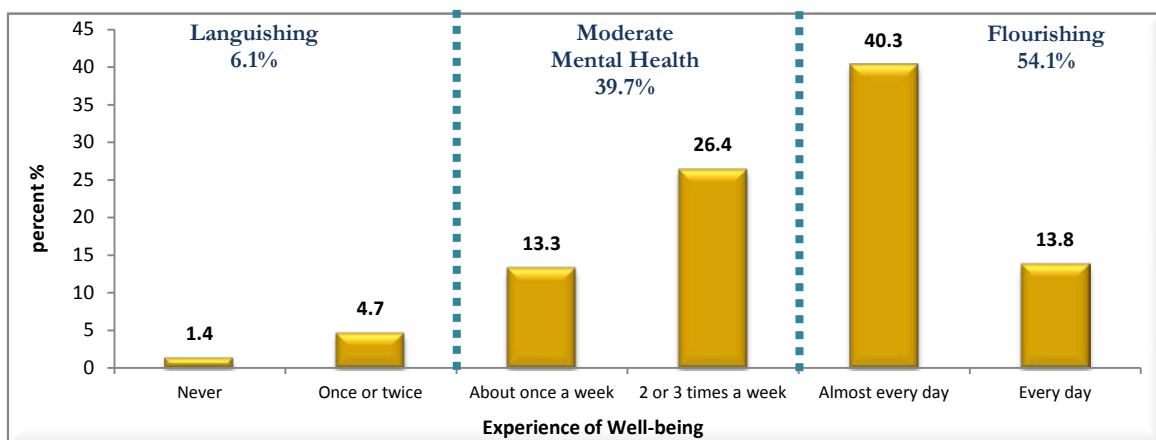

Figure 15 IB MYP students' experience of well-being (MentHC composite measure)

## Gender Differences

Differences between males and females were evident and statistically significant (see Figure 16). Males were more likely than females to be flourishing, while females were more likely to be languishing or to have moderate mental health compared to males (Mann Whitney U,  $Z = -5.7$ ,  $p < .000$ ,  $E.S.(r) = 0.14$ ).

*Flourishing:* As shown in Figure 16, males (59.7%) were more likely than females to report experiencing well-being “almost every day” or “every day” (47.8%) ( $\chi^2 (1) = 25.2$ ,  $p < .000$ ,  $E.S. (Cramer’s V) = 0.12$ ). These findings are consistent with those obtained from Diener et al.’s FloS scores, which also found that males (59.8%) were more likely to have been flourishing than females (50.9%).

*Languishing:* Nearly twice as many females (8.1%) than males (4.4%) were likely to report that their experience of well-being during the past month was “never” or “once or twice” ( $\chi^2 (1) = 11.4$ ,  $p < .000$ ,  $E.S. (Cramer’s V) = 0.08$ ).

*Moderate Mental Health:* A larger proportion of females (44.0%) than males (36.0%) were not languishing or flourishing, and therefore had moderate mental health ( $\chi^2 (1) = 12.0$ ,  $p < .000$ ,  $E.S. (Cramer’s V) = 0.08$ ).

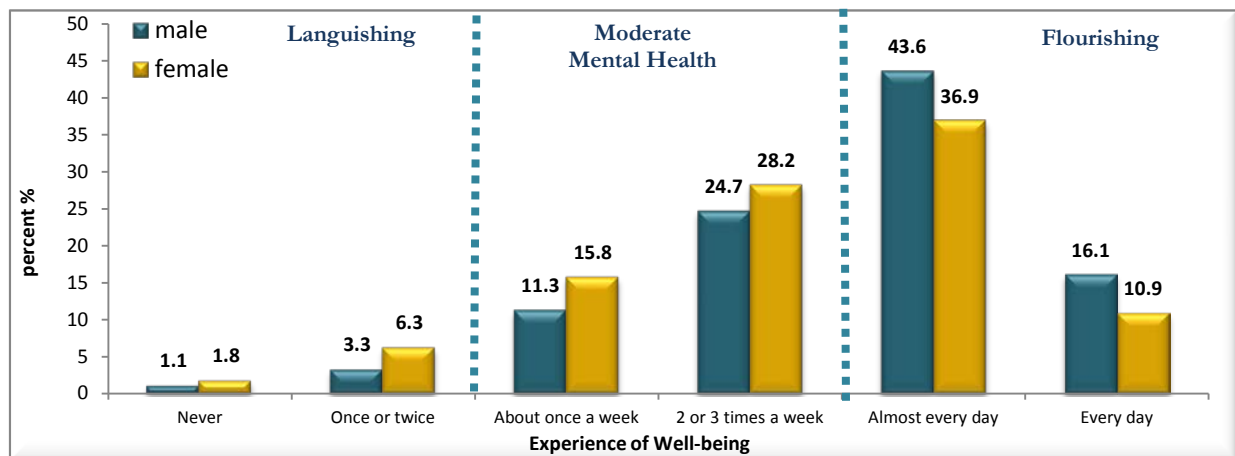

Figure 16 Male and female IB MYP students’ experience of well-being (MentHC composite measure)

## MentHC: Flourishing by Gender and Year Level

Furthermore, as found with FloS scores, controlling for SES and school, there was a pronounced effect from an interaction of gender and year level which indicated that student gender *and* year level were associated with the likelihood of flourishing, languishing or having moderate mental health ( $F(4) = 5.6$ ,  $p < .000$ ). Males and students in the upper years of MYP were more likely to flourish, while females in the lower years of MYP were more likely to be flourishing than females in the upper years of MYP.

An analysis of the results of males only found that the likelihood of flourishing was not significantly different from year to year ( $\chi^2 (4) = 8.7, p > .05, E.S. (Cramer's V) = 0.10$ ). A similar analysis for females found that the likelihood of flourishing decreased significantly in Years 8-10 ( $\chi^2 (4) = 58.2, p < .000, E.S. (Cramer's V) = 0.27$ ). As shown in Figure 17, two in five (40.0%) of Year 10 females were flourishing compared to 87.4% of Year 6 females. These findings suggest that females' sense of mastery/competency as well as satisfaction with life could be declining through the middle years, although since this is cross-sectional data, only a longitudinal study would provide confirmation of this.

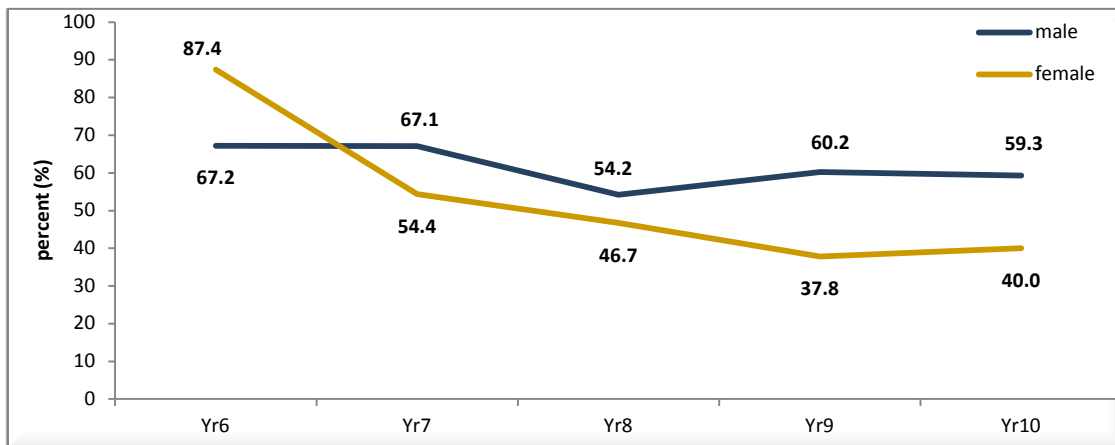

Figure 17 Proportion of males and females flourishing in each year level

### *MentHC: Languishing by Gender and Year Level*

The proportion of male and female IB MYP students that were languishing varied across year levels and by gender. The proportion of female students languishing rose steadily across the year levels, changing from 4.4% in Year 7 to 11.8% in Year 10. (In our sample no Year 6 females reported languishing.) For males, the proportion who were languishing varied from a low of 2.7% (in Year 7) to a high of 5.5% (in Year 8), and in every year level it was less than 6% (see Figure 18).

An analysis of the data of IB MYP males found the likelihood of languishing did not vary significantly from year to year ( $\chi^2 (4) = 3.3, p > .05, E.S. (Cramer's V) = 0.06$ ). However, this was not the case for females. A statistical analysis found an increased probability of languishing for females in the upper years of MYP ( $\chi^2 (4) = 12.6, p < .05, E.S. (Cramer's V) = 0.12$ ).

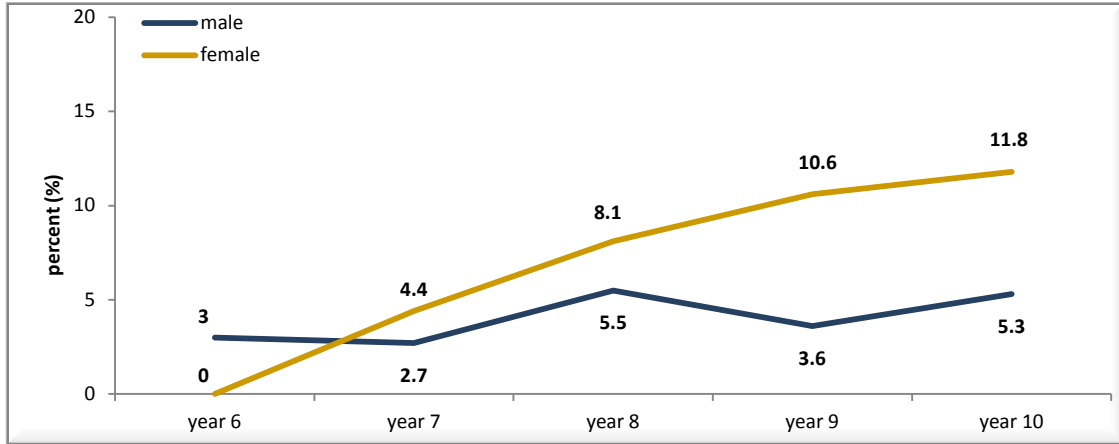

Figure 18 Proportion of males and females languishing in each year level

### *MentHC: Moderate Mental Health by Gender and Year Level*

Male and female IB MYP students differed in the proportions that had moderate mental health across the year levels. With the exception of Year 6, in every year level females were more likely than males to have moderate mental health (see Figure 19).

An analysis of the data of males suggested that the likelihood of having moderate mental health did not vary substantially for males from year to year ( $\chi^2(4) = 5.5, p > .05, E.S. (Cramer's V) = 0.08$ ). However, for females the likelihood of having moderate mental health increased after Year 6 ( $\chi^2(4) = 35.0, p < .000, E.S. (Cramer's V) = 0.21$ ).

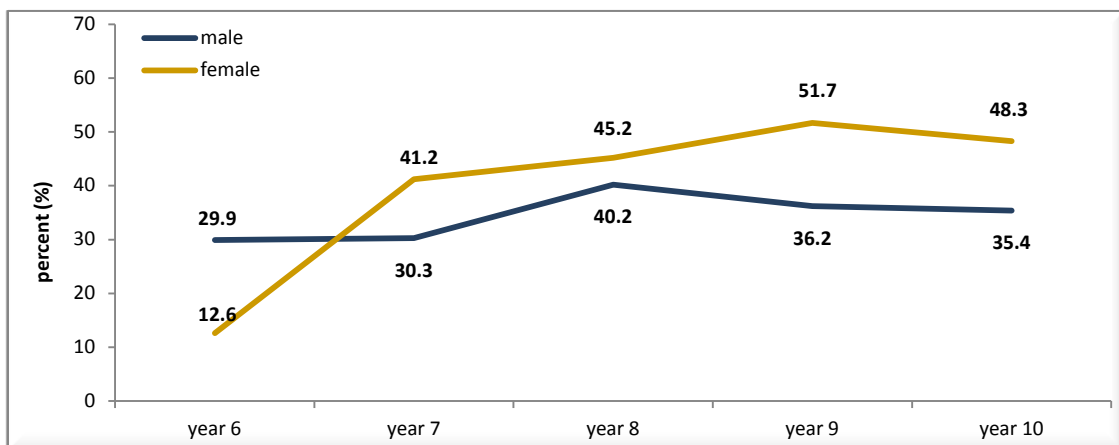

Figure 19 Proportion of males and females with moderate mental health in each year level

An examination of the influence of gender, year level, age, school type and SES on well-being based on the MentHC model was undertaken using a MIMIC model. As shown in Appendix B Figure 4, SES, as well as an interaction effect of gender and year level, influenced well-being, although school type was not statistically significant. Students from less disadvantaged backgrounds were more likely than students from more disadvantaged backgrounds to report high levels of well-being. These MentHC findings are consistent with the findings from the (Diener et al.) FloS score analysis, namely that females in the upper years of MYP were more likely than other students in the IB MYP to show lower levels of well-being. However, once again this influence was weak, with only 7.8% of the variance in well-being attributed to these influences.

## School Well-being Programmes and Approaches

Interviews with IB MYP staff also provided an opportunity to investigate the well-being programmes and approaches being implemented by the schools. Discussions with these participants proved fruitful. They indicated that student well-being was considered important and it was being addressed in IB MYP schools. School personnel revealed that a variety of well-being programmes were delivered in all eight of the study schools. Some programmes were whole year level approaches, such as orientation and transition programmes for Year 6 or Year 8 students to get to know one another as they entered a new school campus. These aimed to assist students to develop friendships and social skills. Staff reported that there were times when the programmes they used targeted specific groups. For example, at one school males and females were separated for some sessions:

*Sometimes we split them into girls and boys separately. So for example this year the Year 8 and 9 girls were separate for a period of four lessons, where they looked at the sexualisation of girls in the media, and how media considers what is beautiful. And the boys did a four week session called 'Revved Up For Boys', and so they were looking at how they can manage their anger when their anger starts to become overwhelming, so what is it that they need to do to make sure that they don't explode. (MYP Co-ordinator)*

Other interventions were sometimes scheduled as a full-day exercise, although most of the schools indicated that there was a regular allocation of time for pastoral care lessons with a care/home group teacher. Special “growth and personal skills” programmes, designed at one school by year level coordinators with input from the school psychologist, were implemented during that time. However, other events sometimes impinged on pastoral care lessons, such as assemblies and sporting events

*... so the programme can become quite disjointed at times; you might have three weeks in a row ... and then none for three or four weeks. (MYP Coordinator)*

At another school these lessons were integrated in aspects of the MYP such as the personal project, and

*during that care group time [there] is [an] introduction to [the] personal project - but there's a lot of well-being activities that go on as well in Year 8. (Well-being Coordinator)*

Furthermore, there was a suggestion that well-being programmes were modified from year to year:

*They sort of change each year depending on what's available, whether we get external providers to come in and present. (Head of Middle School)*

Programme changes were considered necessary in order to attend to the changing needs of adolescents. For example, new programs were introduced to address issues associated with the use of social media, such as cyber-bullying, as this quote from one participant states:

*The plan for next year will change a little bit ... depending on also the needs of adolescents. For example, 10 years ago we weren't doing cyber safety ... so as life changes, as the needs for adolescents change, we obviously need to look at ways to accommodate and change our programmes. (MYP Co-ordinator)*

Programmes were also changed to provide variety for students who had a tendency to perceive different programmes that addressed the same topic as being the same.

*We don't like to just stick with one programme and just run it. We found that whenever you just stick with one programme, kids get bored with it. They need variation, and even though the programme itself might have variation in its delivery, they go "Oh, not this again", sort of thing, because it looks the same. (MYP Co-ordinator)*

Other programmes targeted specific students who were identified by staff as requiring support. These programmes were generally voluntary, although as one participant pointed out, particular targeted students were invited and encouraged to participate:

*... two programmes are voluntary programmes, so they're run after school, so students have to opt in basically, but on occasions we might recommend to students' parents that some students might benefit from being involved as well. (Head of Middle School)*

Staff were astute in recognising student needs and accommodating them. At one school a participant explained,

*we had issues with certain Year nine and 10 girls (just self-esteem), so we put together a group for that, which [outside agency] was able to come in and run ... that went for about six or seven weeks with about 10 girls. (Counsellor)*

Changes to programmes appeared to be in response to student needs and were more common in schools with students from middle to high SES and in the upper years of MYP, although more research would be required to substantiate this supposition.

Furthermore, programmes in the lower years of MYP appeared to be more integrated into the curriculum. As one participant explained:

*A lot of our well-being and stuff we do that always. I mean that stuff that's been embedded ... a lot of that comes through their care group activities and it's embedded in curriculum ... for instance 6/7 you know when we're taking growth and development at the moment and we're not just focussing on the physical, we're looking at the social and emotional as well. (Well-being Co-ordinator)*

This could be associated with the primary education system, where one teacher is allocated a class of students for the full year. There was an awareness that having one teacher for longer periods of time was of benefit to students as it permitted better rapport and relationship building. In some schools an attempt was made to have students allocated to the same teacher for a number of subjects to allow for this. This informal approach



to well-being, which allowed teachers to notice and address student issues, was an approach used by many of the IB MYP staff:

*The good thing about the middle school is that the home room teacher will take their class for at least 3 subjects, so you have that constant contact with the home room teacher ... so even if you do lose that [pastoral care] time we have flexibility within our programmes to be able to talk about issues that arise and things that come up on a day to day basis. (Head of Middle School)*

Indeed, both teachers and senior administrators pointed out that attending to student social and emotional needs involved both an informal as well as formal process:

*it's [SEL] embedded in curriculum ... It's always there particularly ... when you're in a classroom environment where you're working with the kids across a range of areas, you're doing that stuff. The kids wouldn't necessarily be able to articulate it, but it's there all the time and you're engaging in it and that's what we do. That's what makes us successful as practitioners. (Year 6/7 teacher)*

*We have a well-being programme. We're talking about, there's a couple of levels here, we're talking about well-being across all subjects and all teachers at all times, so that's informal, but we also have a formal well-being programme, there's two lessons a week, and they look at confidence, resilience, all those personal qualities you want to develop in students. (Head of Middle School)*

A school psychologist and, or counsellor was available to students within each school, or visited a school regularly. This effort was acknowledged by students in all of the focus groups. Students remarked:

*[school helps] in every way. They could help you as much as you ask for. (Male, Year 10)*

*The school definitely does make an effort for those who are struggling to develop their own natural ability to deal with problems and understand social situations they're in. (Male, Year 9)*

*There's teachers such as you know, particular teachers at school that if they see you looking unhappy or sad or just unwell, they'll look you know are you OK? Do you need to talk? ... and many teachers are like that. If they see you that they think there is something wrong they will almost always jump in to check. (Female, Year 9)*

While students felt that most teachers were supportive and caring, they also noted not all teachers matched this profile:

*I feel like some teachers don't - like some are really good at building relationships with students, but others don't - they just act like they're there to teach you and that's it. (Female, Year 8)*

*There's always the strict, boring teachers that don't like have any - like, they don't change it ... they just - same thing all the time. It gets really on your nerve ... I've had one every year. (Male Year 10)*

At one school situated in a low SES area, there was a focus on teaching students to develop healthy relationships and a federally funded programme used with the Year 6s and 7s was being implemented “to try and curb the risk of domestic violence later on – so prevention rather than cure” (*Well-being Coordinator*).

Despite the schools' efforts, some students, particularly males in the upper years of MYP, felt reluctant to make use of the social and emotional support that was available to them, as the following quotes show:

*I think as you go into the higher grades you have a tendency to more likely go to a friend rather than a teacher. You kind of keep them as last resort. If there is an incident like bullying you try and resolve it by yourself. You try and find a resolution without having to bring in teachers. (Male Year 9)*

*We've got a year level coordinator, but you don't really feel like it's safe talking about an emotional... like talking about, like your emotions ... you don't really want to tell your teacher about your private life, because that's out of school. (Male, Year 10)*

*I really do believe that in a professional area, like when you're actually working with students, not really talking to them about their problems. I feel like teachers just can't really - it's not something that they care for just because ... that's just not a part of their job. (Female Year 9)*

*If we had a personal life problem then we would obviously go to someone in our personal life, not in our learning life. (Male, Year 10)*

## Discussion

In his study, Keyes (2006) found that a smaller proportion of adolescents aged 15-18 were flourishing compared to the proportion of 12-14 year olds who were considered to be flourishing. Venning et al. (2012) also found that flourishing was lower for older South Australian adolescents. Lower-levels of well-being amongst older adolescents were also found in our study. Our findings partly support those of Venning et al. who found that the likelihood of languishing amongst South Australian adolescents was relatively stable across the age groups of 13-17 years, as we found this only to be the case for males.

It may be that the quantitative data reflects the state of affairs described by participants in the qualitative study of the delivery of well-being programmes in schools. Student well-being appeared to be highest in Years 6 and 7, at a time when, according to interview participants, well-being is embedded into the curriculum, rather than attended to on special days or weekly lessons, which occurred when there were no other pressing events.

Keyes made no mention whether the decline in well-being with age could be attributed mostly to girls, as our study shows.

The small effect sizes suggest that any gender differences are not solely due to being male or female or to being in a particular year level. Rather other factors must be present that contribute to these differences.



# Positive Outlook and Positive Emotional State

---

*Positive Emotional State and Positive Outlook can easily be interpreted as Subjective (Hedonic) Well-being and Psychological (Eudaimonic) Well-being (Liddle & Carter, p. 14).*

In the previous two chapters we discussed findings using two scales (FloS and MentHC) to measure, broadly, the construct of flourishing in IB MYP students. In this chapter we report the findings from a third measure that is also designed to measure well-being.

Liddle and Carter (2010) acknowledged the need to differentiate mental health and mental illness by using a positive measure of healthy functioning to assess well-being rather than relying on a deficit-based understanding of mental health. Using an approach based in positive psychology, they developed the Stirling Children's Well-being Scale that contained items that were positively worded and were suitable for children.

## Stirling Children's Well-being (StirCWB) Scale

The StirCWB Scale was designed for students aged 8-15. The items in the scale were piloted with children and their feedback was used to refine the questions so that the scale had good theoretical grounding and “was understood ... and ... perceived by children to be measuring well-being” (Liddle & Carter, p.7).

Comprising 12-items, the StirCWB Scale assesses emotional and psychological well-being and the level of a child's Positive Emotional State (PES) as well as Positive Outlook (POL). Testing by Liddle and Carter (2010) found that the scale showed good internal, as well as external, reliability. The scale also includes a social desirability subscale of three items, which can be used to determine socially desirable responding and sets of similar responses, as well as encourage respondents to be actively engaged with responding to questionnaire items.

Participants in our study completed the StirCWB questionnaire as part of the WBQ suite of questions. Responses to the social desirability items were examined together with other responses to items in the WBQ. Following Liddle and Carter's (2010) suggestion, questionnaires were discarded where it was evident that there had been socially desirable responding.

## StirCWB: Total Scores

Students' responses to items on the StirCWB Scale were used to calculate a total well-being score for each respondent, as suggested by Liddle and Carter (2010). Total StirCWB scores ranged from 12 to 60 and the mean was 42.1 (S.D. = 8.6).

As shown in Figure 20, 50% of scores fell between 39 and 49 (inclusive). A small proportion (8.4%) of students had scores less than 30. Liddle and Carter (2010) suggested these scores are indicative of poor mental health. This proportion is comparable with the proportion considered to be languishing (6.1%) determined by Keyes's MentHC.

It was possible to make comparisons of this IB MYP sample with the students Liddle and Carter (2010) sampled in their study of 8-15 year olds. The mean StirCWB score in their study was 43.5 (S.D. = 6.7), which was slightly higher than the mean in our study of 42.1 (S.D. = 8.6). However, Liddle and Carter's study comprised of younger children, and since (according to Liddle & Carter) "scores showed a decline in well-being with age" (p. 18), a higher StirCWB mean score would be expected from a younger group. Nonetheless, the mean score from our study fell within one standard deviation of the mean in Liddle and Carter's study, in an acceptable score range of 36.8 to 50.2.

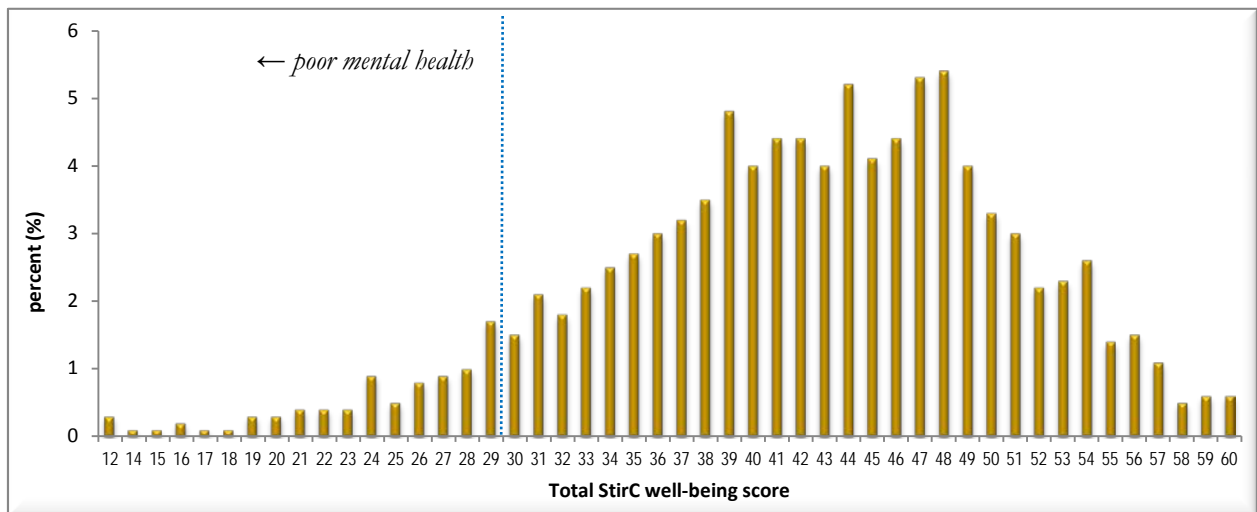

Figure 20 Total StirC well-being scores of IB MYP Students

## StirCWB by Gender

More males than females had high scores on the StirCWB ( $F(1) = 37.5$ ,  $p < .000$ ,  $E.S.(r) = 0.15$  – see Figure 21). This suggested that males were more likely to be experiencing well-being than females. Using the cut-off

score of 30, as suggested by Liddle and Carter (2010), 12.0% of females compared to 5.2% of males were experiencing poor mental health.

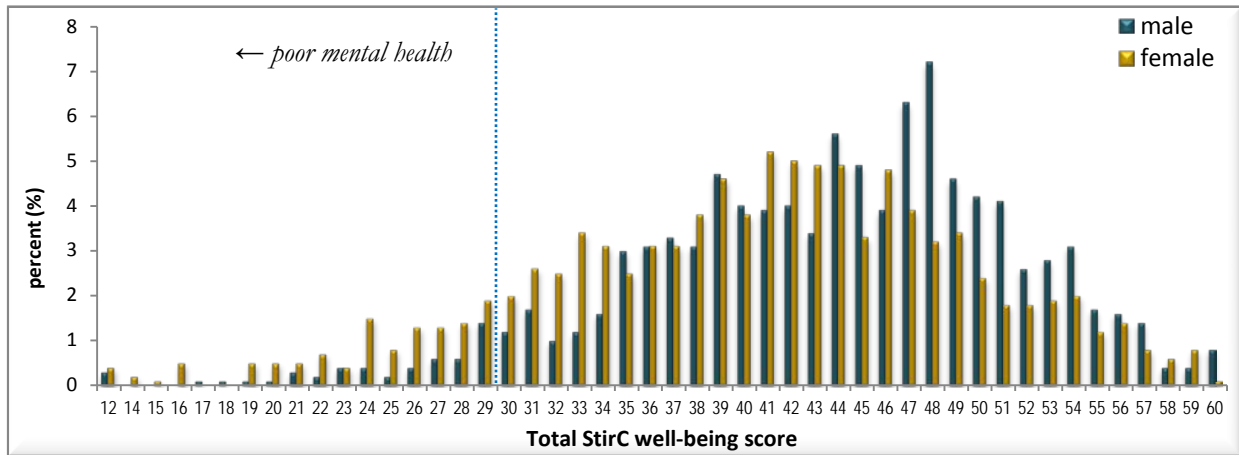

Figure 21 Total StirC well-being scores of male and female IB MYP students

### StirCWB by Gender and Year Level

The same pattern of findings found in the previous measures i.e. FloS and MentHC, was evident after controlling for SES and school. Males were more likely to have higher StirCWB scores than females and females' StirCWB scores were more likely to be lower in the upper years of MYP than the lower years of MYP ( $F(4) = 9.3$ ,  $p < .000$  – see Figure 22).

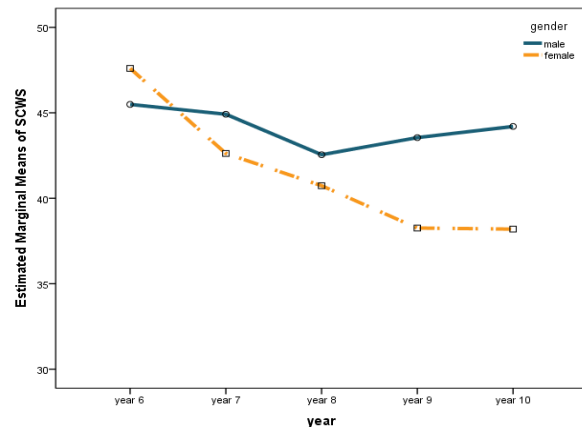

Figure 22 Total StirC well-being scores of male and female IB MYP students by year level

### Stirling Children's Well-being (StirCWB) Model

A Confirmatory Factor Analysis (CFA) of the StirCWB Scale found that it was an adequate fit with our data ( $\chi^2(53) = 556.5$ ,  $p < .000$ ; RMSEA = 0.071, 90% C.I.: 0.066 – 0.077, probability RMSEA  $\leq .05 = 0\%$ ; CFI = 0.948; TLI = 0.935; SRMR = 0.040). However, there was a significant improvement in how well the model fit the data when one item from each of the factors was dropped (see Appendix B Figure 5). This improved model was used in subsequent analyses.

An examination of factors, such as gender, year level, age, SES and school type (using a MIMIC model), associated with a positive emotional state and a positive outlook found that an interaction effect of gender and year level had the greatest influence (see Appendix B Figure 6). The moderately-strong regression coefficient (-0.546) of gender and year level on positive emotional state suggests that females in the upper years of MYP were likely to have lower scores on this factor. Similarly, the moderately-strong regression coefficient (-0.514) of gender and year level on positive outlook, suggests females in the upper years of MYP were also likely to have lower scores on positive outlook. In contrast, the regression coefficient of SES was of much less influence, while the influence of age and school type was not significant. However, together these factors were associated with only 7.3% of the variance of having a positive emotional state and 11.1% of variance of having a positive outlook. This suggests that there must be other factors besides gender and year level associated with having a positive outlook and positive emotional state.

In the next section, positive outlook and positive emotional state factors are examined separately.

## Positive Outlook

Factor score coefficients generated from the CFA analysis were used to determine positive outlook scores for IB MYP students. As shown in Figure 23, over half (60.1%) of the IB MYP students reported experiencing a positive outlook “quite a lot” or “all of the time”, while less than one percent reported “never” feeling this way.

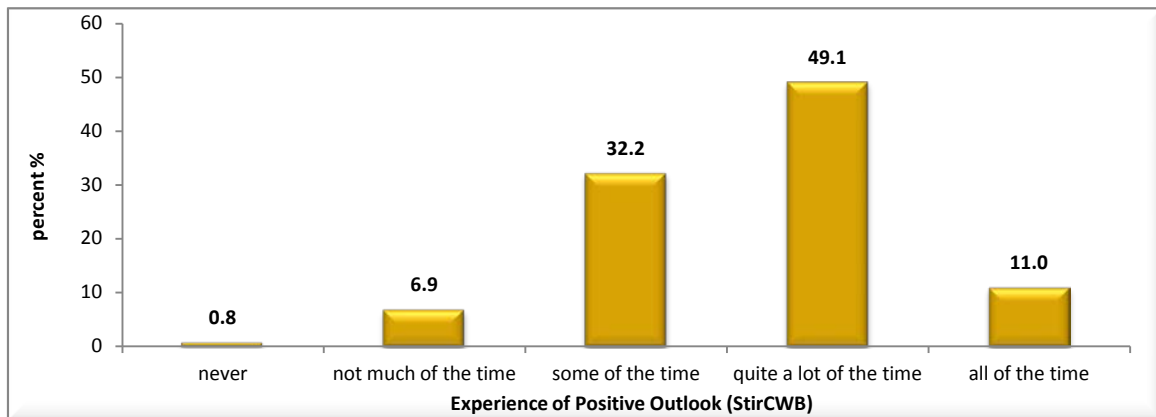

Figure 23 IB MYP students' experience of positive outlook

As shown in Figure 24, males were more likely than females to report experiencing a positive outlook “quite a lot of the time” or “all of the time” (66.9% vs 52.4%)

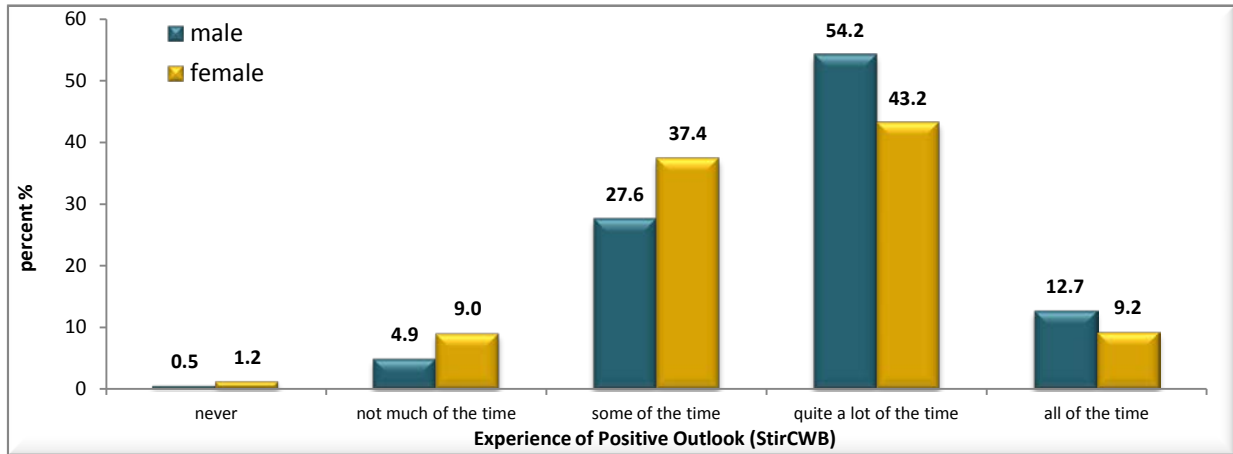

Figure 24 Male and female IB MYP students’ experience of positive outlook

### Positive Outlook by Gender and Year Level

Experiencing a positive outlook varied significantly between males and females and between students in different year levels. There was a interaction effect of year and gender ( $F(4) = 5.0, p < .000$  - see Figure 25). Students in the lower years were more likely than students in the upper years of MYP to have a positive outlook, particularly females.

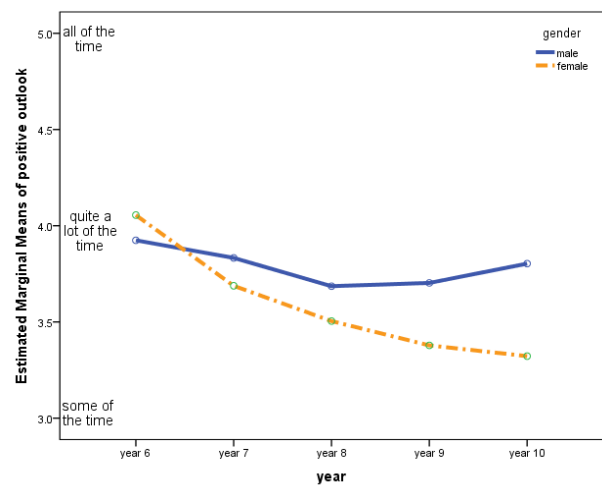

Figure 25 Male and female IB MYP students’ experience of positive outlook by year level

### Positive Emotional State

Factor score coefficients generated from the CFA analysis were used to determine positive emotional state scores for each IB MYP student. As shown in Figure 26, just over half (52.4%) of the IB MYP students reported experiencing a positive emotional state “quite a lot” or “all of the time”, while less than two percent reported “never” feeling this way.



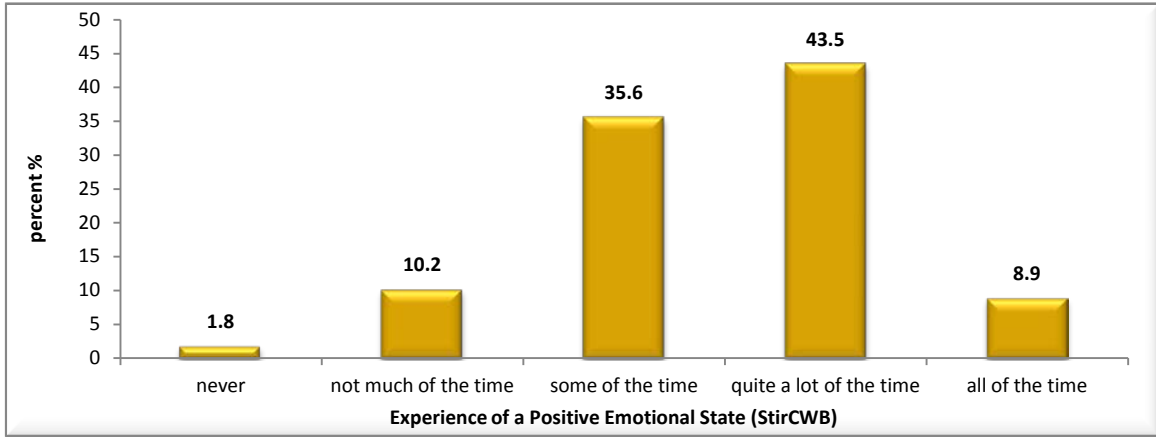

Figure 26 IB MYP students' experience of a positive emotional state

A positive emotional state was more likely to have been an experience of males rather than females (58.3% vs 45.8%), as something they experienced “quite a lot of the time” or “all of the time”, as shown in Figure 27

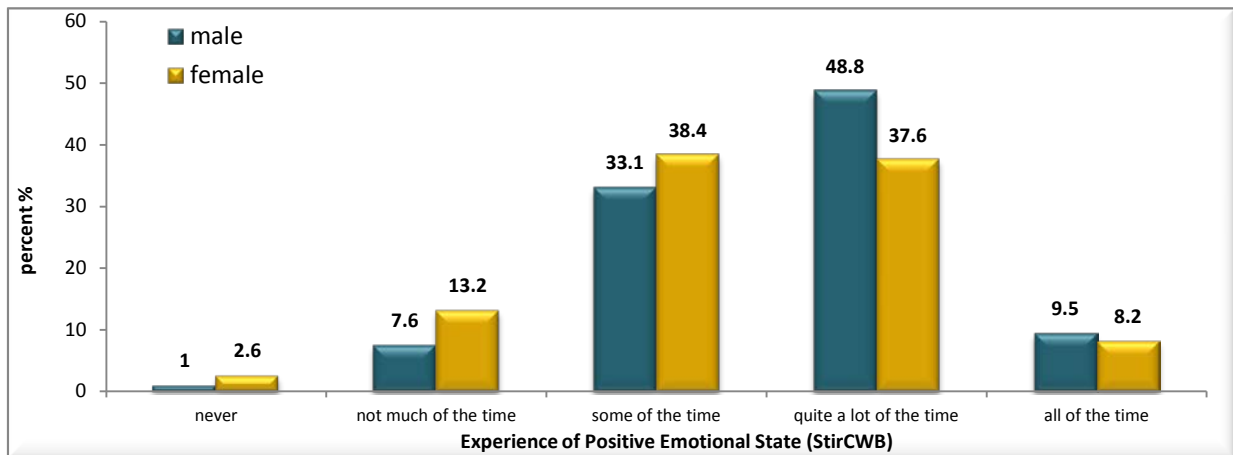

Figure 27 Male and female IB MYP students' experience of a positive emotional state

## Positive Emotional State by Gender and Year Level

Experiencing a positive emotional state varied significantly between males and females and between students in different year levels. There was an interaction effect of year and gender ( $F(4) = 7.2, p < .000$  - see Figure 28). The experience of a positive emotional state varied significantly between males and females and students in different year levels. Males were more likely than females to have a positive emotional state. Students in the lower years were more likely than students in the upper years of MYP to have a positive emotional state, particularly females.

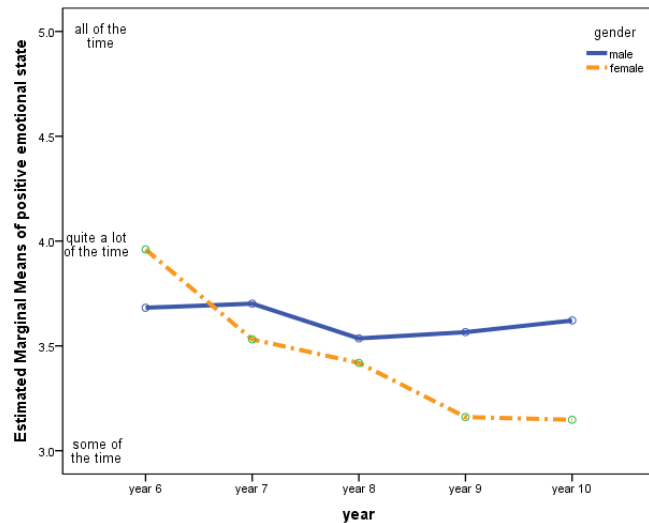

Figure 28 Male and female IB MYP students' experience of a positive emotional state by year level

## Discussion

This chapter has provided yet another perspective of well-being by conceptualizing a positive outlook and a positive emotional state as important indicators of well-being. Using this perspective to examine well-being, our findings were well aligned with the findings in the previous chapters concerning well-being. Once again, males were more likely than females to show signs of well-being, with a greater proportion of males than females reporting a positive outlook and a positive emotional state. Gender differences of this kind are not an uncommon finding in mental health and well-being studies. For example, very recent unpublished results from Scotland using the StirWB Scale also indicate a trend for more girls than boys to report poor mental health (P. Davidson, 8/4/2014) and research by Green, McGinnity, Meltzer, Ford and Goodman (2005) of 11 to 15 year olds in the UK found emotional disorders were higher in girls (4.1%) than boys (3%). Another recent study of the status of girls in Indiana, USA, by Kuter & Deom (2013) reported that daily feelings of sadness or hopelessness were more likely to have been conveyed by females than males. The Indiana study also found that the percentages of girls reporting this disposition increased from grade six to grade eight or nine and then decreased.

IB MYP students in the lower years of MYP were also more likely than students in the upper years of MYP to experience a positive outlook and a positive emotional state, and therefore well-being, corroborating findings using FloS and MentHC scores. While it would be speculative to explain this decline in well-being

across the middle years without further research, Liddle and Carter (2010) have provided some insights worthy of consideration in this regard. They have suggested that some items capturing self-acceptance used in well-being scales require “a level of abstract introspection that is not established at the younger ages” (p. 14). They have argued that a sense of self-acceptance is dependent more on external than internal factors at a young age. Children’s self-acceptance is therefore associated, they pointed out, with a desire for possessions and qualities that others are observed to have. As children grow however, and begin to detach from their dependence on parents and family, they commence to form their identity and develop a more integral sense of self. Using this understanding of child development, Liddle and Carter have suggested that children respond to self-acceptance questionnaire items differently to adolescents. Their responses are prone to ceiling effects as they are more likely to respond positively to these items. Moreover, it could well be, as Liddle and Carter have also suggested, that older students are more likely to understand the questions and respond more appropriately. This could be one reason why the well-being scores of young people in our study have been consistently higher than those of young people in the upper years of MYP. However, this reason would not explain the decline in well-being characteristically seen in our findings amongst females in Years 9 and 10. Liddle and Carter have also proffered another explanation for the decline in well-being with age. They have also proposed that the decrease in well-being with age “has an intuitive logic” since pressures to perform academically, socially and independently increase with age in the teenage years. Further research would be needed to investigate the complexities of growing up and the impact of the various pressures teenagers face as they progress through secondary school.

# Student Well-being and the IB Learner Profile

## Profile

---



Year 6 Male aged 11

The philosophy underpinning the International Baccalaureate, which encompasses an holistic view of education, has deep connections with the ideas behind social and emotional education for students. Social and emotional education plays a key role in the IB MYP curriculum to develop knowledgeable, balanced and caring students, and IB schools are encouraged to increase their focus on social and emotional learning in the classroom.

Many of the traits comprising the IB Learner Profile (see Table 7) go beyond intellectual and academic development and are conducive to the development of social and emotional well-being. In an exploration of social and emotional abilities and the IB learner profile, Hannah (2011) suggested that attributes of the IB Learner Profile facilitate the attainment of social and emotional skills such as a focused mind, greater awareness of self and others, an ability to suspend judgment, non-impulsive deliberate decision making and emotional confidence (see Table 7). These elements correspond to the holistic learning goals of the IB, which aim to help students develop respect for themselves, others and the world around them. Being ‘caring’, ‘balanced’ and ‘reflective’ are three aspects of the Learner Profile that particularly relate to social and emotional well-being, and these formed another focus of our study.

### Caring

Research has shown that a caring disposition that incorporates empathy, compassion and a genuine commitment to service, promotes general well-being. A study of communal orientation by Le, Impett, Kogan, Webster and Cheng (2013) found that in addition to experiences of positive emotions, “a caring disposition can promote well-being both personally and interpersonally” (p. 704). They found that the personal and interpersonal well-being of those with a caring disposition transcended a variety of relationship contexts, so that it was not just associated with strangers or patients. Furthermore, those who were not concerned with

reciprocated care, were more likely to experience boosts in well-being and satisfaction. Practicing random acts of kindness has been found to increase satisfaction with life (Buchanan & Bardi, 2010), while many other studies have shown that altruism, volunteering and community service are positively related to well-being (e.g. Dunn, Aknin, & Norton, 2008; James, 2011; Meier & Stutzer, 2004; Mellor et al., 2008).

**Table 7** IB Learner Profile and social and emotional connections

IB learners strive to be:		Social and emotional skills (Hannah, 2011)
	They develop their natural curiosity. They acquire the skills necessary to conduct inquiry and research and show independence in learning. They actively enjoy learning and this love of learning will be sustained throughout their lives.	more focused mind, looking inward as well as outward
<b>Knowledgeable</b>	They explore concepts, ideas and issues that have local and global significance. In so doing, they acquire in-depth knowledge and develop understanding across a broad and balanced range of disciplines.	deeper knowledge of self
<b>Thinkers</b>	They exercise initiative in applying thinking skills critically and creatively to recognise and approach complex problems, and make reasoned, ethical decisions.	more focused mind, looking inward as well as outward
<b>Communicators</b>	They understand and express ideas and information confidently and creatively in more than one language and in a variety of modes of communication. They work effectively and willingly in collaboration with others.	applying care [for others] and deeper awareness
<b>Principled</b>	They act with integrity and honesty, with a strong sense of fairness, justice and respect for the dignity of the individual, groups and communities. They take responsibility for their own actions and the consequences that accompany them.	more self-aware, controlled and with a moral compass
<b>Open-minded</b>	They understand and appreciate their own cultures and personal histories, and are open to the perspectives, values and traditions of other individuals and communities. They are accustomed to seeking and evaluating a range of points of view, and are willing to grow from the experience.	being able to suspend judgment
<b>Caring</b>	They show empathy, compassion and respect towards the needs and feelings of others. They have a personal commitment to service, and act to make a positive difference to the lives of others and to the environment.	deeper awareness of self and others' emotions and well-being
<b>Risk-takers</b>	They approach unfamiliar situations and uncertainty with courage and forethought, and have the independence of spirit to explore new roles, ideas and strategies. They are brave and articulate in defending their beliefs.	more confident emotionally
<b>Balanced</b>	They understand the importance of intellectual, physical and emotional balance to achieve personal well-being for themselves and others.	not impulsive, more deliberate decision-making
<b>Reflective</b>	They give thoughtful consideration to their own learning and experience. They are able to assess and understand their strengths and limitations in order to support their learning and personal development.	more finely tuned to understanding self and others

## Empathy

The IB Learner Profile also upholds that as students strive to become caring they show empathy, respect and compassion. The concept of empathy, which encapsulates the ability to feel for or understand another person, is an aspect of human responding that is crucial for understanding positive development. Several

researchers (Hoffman, 2000; Miller & Eisenberg, 1988) have shown that in addition to motivating people to help others and evoking a desire for justice for others, empathy also inhibits aggression and facilitates people's socially competent interactions. In this respect, it could be predicted that empathic students would be less engaged in bullying, and would act to defend and support victims against bullying. Indeed, several researchers have found a negative association between bullying and overall empathy (Gini, Albiero, Benelli, & Altoe, 2007; Jolliffe & Farrington, 2006; Kokkinos & Kipritsi, 2012; Warden & Mackinnon, 2003) for it seems that the expression of antisocial behaviour is impeded through an understanding of the emotions others are experiencing.

In a review of 58 research articles on empathy, Cotton (2001) noted that empathy was regarded as "a key attribute of a successful learner" (p. 8) and was associated with critical and higher-order cognitive skills. Researchers generally agree that empathy comprises two facets, which are both necessary for empathy (Garton & Gringart, 2005). One is an affective capacity, which involves a response congruent with another person's emotional state, and the other is the cognitive ability to intellectually understand another person's perspective and feelings (Blair, 2005; Eisenberg & Strayer, 1987). According to Van der Graaff, et al., (2013) "cognitive empathy, or perspective taking, can be defined as the awareness and understanding of another's emotion" (p. 1), while affective empathy is associated with vicarious experiences that are consistent with what another person is feeling. Shanafelt et al. (2005) have described the difference between the two components. An individual has an emotive response to the feelings that another is experiencing when exercising the affective component of empathy, but must renounce being completely self-oriented to gain insight of another's perspective and the effect it has on feelings, in order to have cognitive empathy. This distinction is important as there is some evidence presented by Sutton, Smith and Swettenham (1999) that suggests that cognitive empathy is associated with some forms of bullying, as an understanding of others' mental states, and possessing advanced "theory of mind" skills, enables some bullies to better target their victims (Andreou, 2004).

Nonetheless, the literature suggests that people who are empathic are more likely to feel connected to others and to experience a positive effect such as happiness (Mehrabian, 2000). Several studies have suggested that empathy enhances social and emotional well-being. For example, in a study of medical residents Shanafelt et al. (2005) found a significant correlation between mental well-being and cognitive empathy scores, and Tkach (2006) found that individuals who systematically displayed empathy and were kind to others reported higher levels of subjective well-being and happiness, while Wei, Liao, Ku, and Shaffer (2011) found a positive relationship between being empathetic to others and subjective well-being amongst a sample of college students and older community adults.

Our study incorporated measures of cognitive and affective empathy using the measure of empathy developed by Garton and Gringart (2005) for young Australian children (aged 8 & 9), as well as measures of

students' involvement in bullying using the Peer Relationships Scale (Rigby & Slee, 1991) to further examine the ideas discussed above.

## Empathy

Garton and Gringart's (2005) Empathy Scale comprises two subscales, namely affective and cognitive empathy. CFAs were undertaken to examine the two sub-scales. After some trimming, the scales were a good fit with the data (see Appendix B Figure 7). The factor score coefficients derived from the final CFA analysis were used to calculate cognitive and affective empathy scores for each student.

### Cognitive Empathy

Factor score coefficients were used to calculate the level of cognitive empathy of IB MYP students. Cognitive Empathy scores ranged from 5 to 25 and the mean was 16.3 (S.D. = 3.9).

It was possible to calculate the cognitive empathy latent variable based on weighted items that comprised this factor. Cognitive empathy scores were calculated for each student using this measure and as shown in Figure 29, nearly two in five (39.4%) IB MYP students reported that indicators of cognitive empathy, such as “when people around me are nervous and worried, I get a bit scared and worried too” were “very” or “fairly like” them.

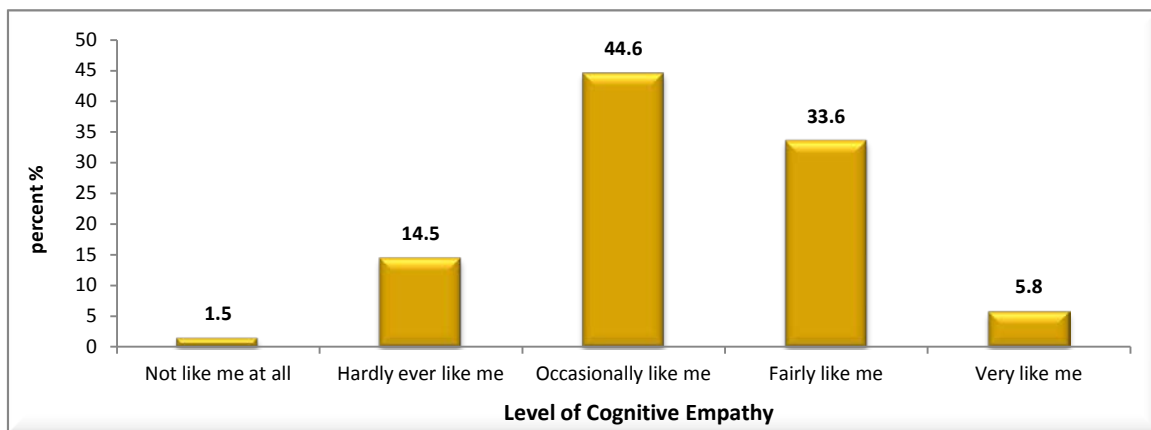

Figure 29 Level of cognitive empathy of IB MYP students

### Cognitive Empathy by Gender and Year Level

Females generally had more cognitive empathy than males ( $F(1) = 194.7, p < .000, E.S.(r) = 0.32$ ) and students in the lower years of MYP had greater cognitive empathy than those in the upper years of MYP ( $F(4) = 4.0, p < .000$  – see Figure 30). A contrast analysis found that only Year 6 scores were significantly different from all other year levels. This suggests that there was no change in the level of cognitive empathy in the high school years. There was no interaction effect of gender and year level.

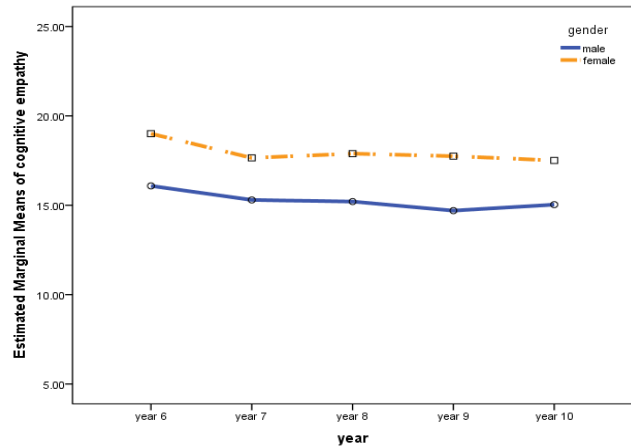

Figure 30 Mean cognitive empathy scores of male and female IB MYP students by year level

### Affective Empathy

The other empathy subscale was affective empathy. Factor score coefficients from the final CFA were used to calculate an Affective Empathy score for each student. Affective Empathy scores ranged from 5 to 25 and the mean was 17.5 (S.D. = 3.9).

Using the data available, it was possible to calculate the affective empathy latent variable based on weighted items that comprised this affective empathy factor. As shown in Figure 31, just over half (52.2%) IB MYP students reported that the descriptors of affective empathy, such as “I want to help people who get treated badly”, were “very” or “fairly like” them.

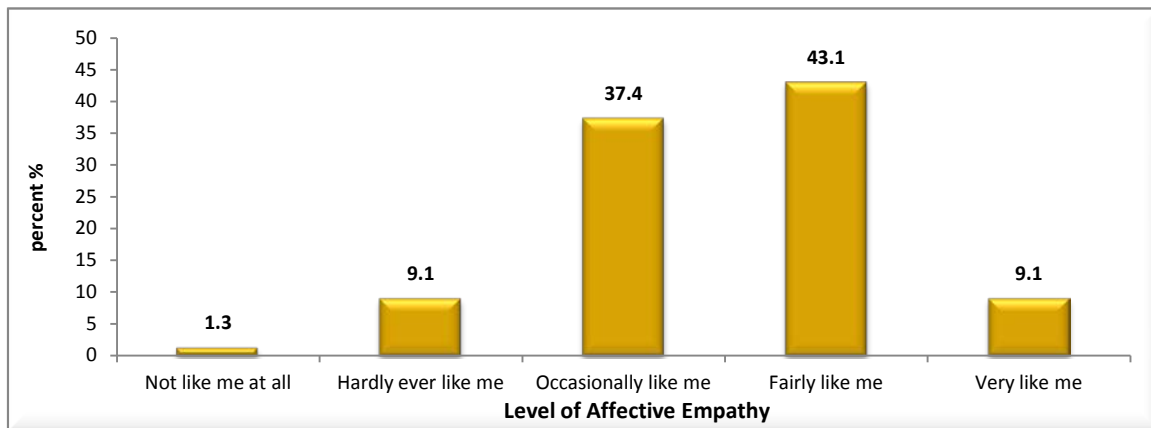
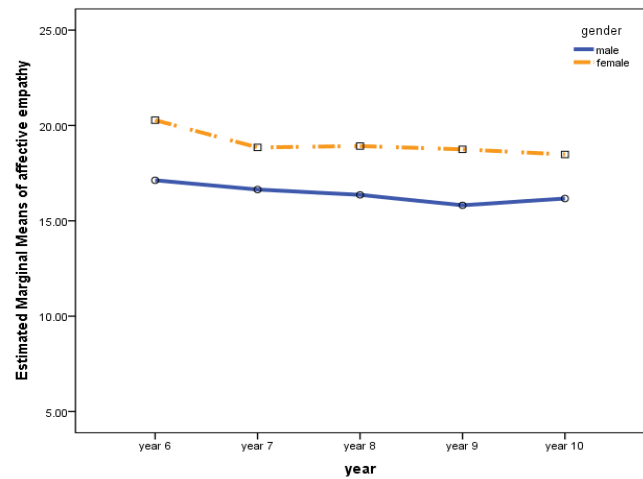

Figure 31 Level of affective empathy of IB MYP students



### ***Affective Empathy by Gender and Year Level***

Controlling for SES and school, females generally reported more affective empathy than males ( $F(1) = 190.9, p < .000, E.S.(\epsilon) = 0.31$ ) and students in the lower years of MYP reported higher affective empathy than those in the upper years of MYP ( $F(4) = 4.9, p < .000$  - see Figure 32). A contrast analysis found that only Year 6 scores were significantly different from all other year levels. This suggests that there was no change in the level of affective empathy in the high school years. No interaction effect of gender and year level was found.



**Figure 32** Mean affective empathy scores of male and female IB MYP students by year level

### ***Empathy and Well-being***

As discussed above, the research literature suggests that empathy is associated with well-being. The data obtained from the WBQ allowed us to further examine this hypothesis. We tested this hypothesis in our study by examining the association of empathy with all three measures of well-being, as described in chapters 3, 4 and 5, using regression analysis in structurally equation modelling.

The results show (see Figure 33 (a) – (c)) that affective empathy was predictive of all our measures of well-being, namely of

- Psychological flourishing (FloS)
- MentHC
- StirCWB

In other words, students with high levels of affective empathy were more likely to have high well-being scores. These students were more likely to be flourishing, or have social, emotional and psychological well-being, be experiencing a positive emotional state or positive outlook. In direct contrast, cognitive empathy was found to be a predictor of low levels of all three measures well-being (i.e., FloS, MentHC and StirCWB). However, further analyses found that affective empathy was only associated with a small amount of the variance of well-being, ranging from 10%-14% for well-being measures (FloS and MentHC) and about 6% for Positive Emotional State and Positive Outlook.

(a) Empathy and FloS

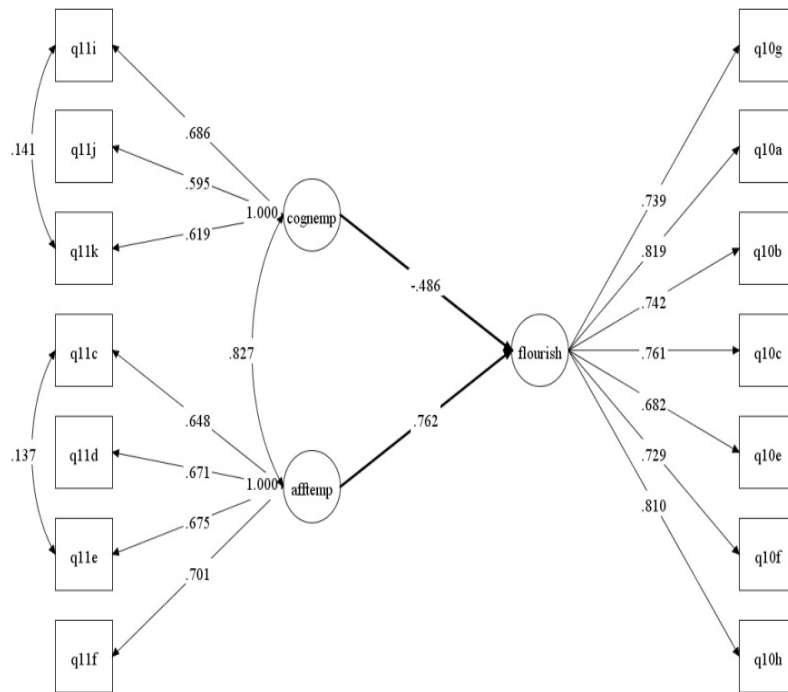

$\chi^2 (72) = 303.0, p < .000$   
 RMSEA: 0.041  
 90% C.I.: 0.037 – 0.046  
 Probability RMSEA < .05: 0.998  
 CFI: 0.970  
 TLI: 0.963  
 SRMR: 0.043  
  
 $R^2 (\text{flourish}) = 20.4\%$

(b) Empathy and MentHC

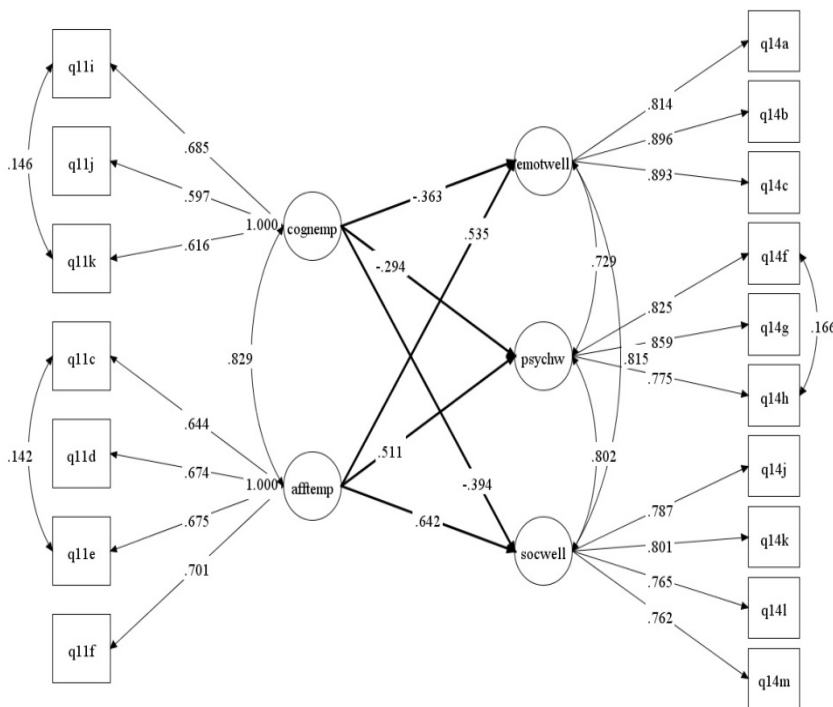

$\chi^2 (106) = 456.5, p < .000$   
 RMSEA: 0.042  
 90% C.I.: 0.038 – 0.046  
 Probability RMSEA < .05: 0.999  
 CFI: 0.972  
 TLI: 0.964  
 SRMR: 0.044  
 $R^2 (\text{emotional well-being}) = 9.6\%$   
 $R^2 (\text{psychological well-being}) = 9.8\%$   
 $R^2 (\text{social well-being}) = 14.8\%$

(c) Empathy and StirCWB

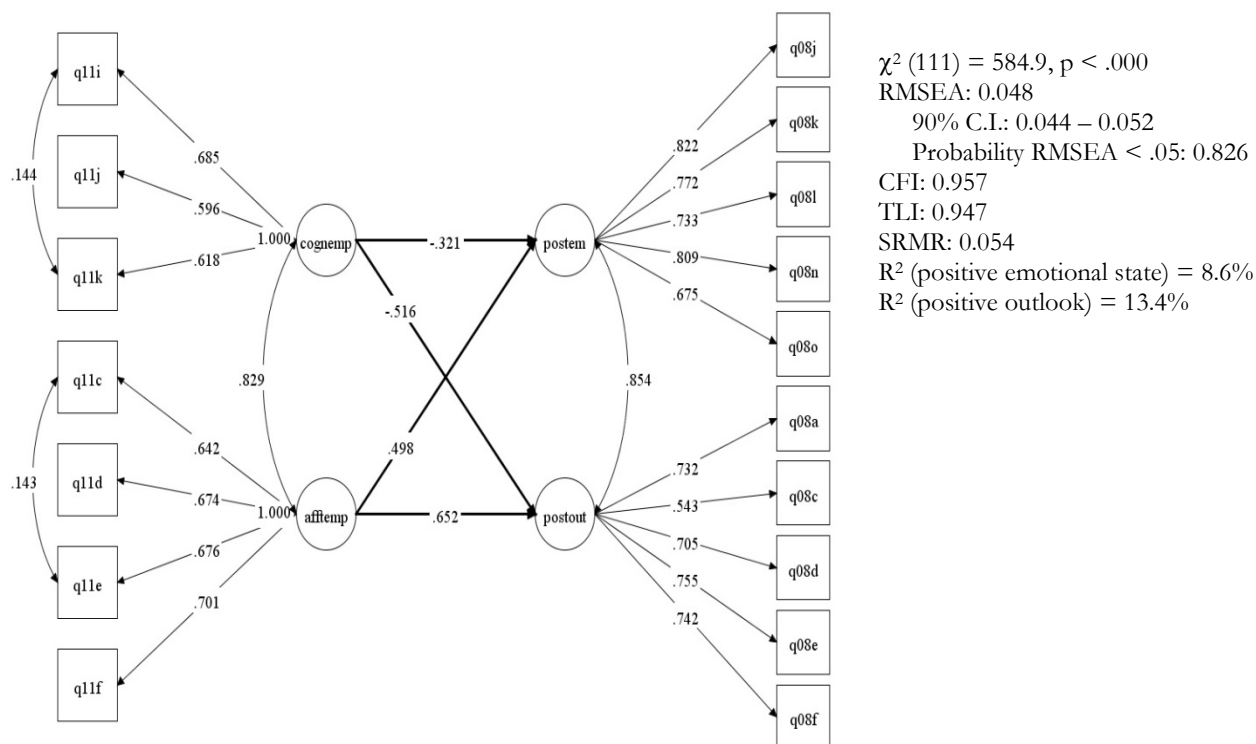

Figure 33 Cognitive and affective empathy as predictors of well-being

## Developing Student Empathy

Interviews with staff provided evidence that schools were engaged with developing empathy amongst students. Some interviewees in Catholic schools indicated that this was facilitated through religious education and the promotion of the Catholic ethos, which endorses a compassionate regard for others less fortunate.

*In our RE programme we run Project Compassion each year. All of the students will do some of the work which is around Project Compassion and ... online Project Compassion will have the stories of usually four or five people from different places around the world ... what is that person's story and what are their needs? How do their needs differ from our needs? That sort of thing is really useful. (Head of Middle School)*

As one school principal pointed out, empathy is “part of the IB philosophy” so the Catholic standpoint supports that empathic disposition. The following quotes from two MYP coordinators present the expectation that empathy is instinctively engendered through a study of other people, and this appears to be a common approach used in schools. As two participants explained:

*They're developing that awareness and they're empathising with other countries and thinking about bigger issues such as economy ... Our novel studies this term is looking at asylum seekers and refugees, so they're engaging with these topics that are international in focus and developing that awareness that otherwise isn't there. (MYP Coordinator)*

*It's certainly there within the curriculum through topics that are covered in things like, you know, global issues, and those sorts of things. It's quite evident there. It would be build very much through things like English texts that are chosen, so you know, looking at stories, you know Indigenous stories or many other things like that. (MYP Coordinator)*

According to some staff, the international programme inherent in IB was useful for generating student empathy, particularly when third-world countries were being studied and explored, as the following quote suggests.

*One of the things being an international programme is being able to look at things from a different perspective. So I think having opportunities to, within the work that we're doing to be able to look at the fact that the perspective that we're coming from is, you know, a student in Adelaide South Australia might be very different from another student the same age looking at this issue from a different perspective from a different country. (Head of Middle School)*

In addition to studying other people and cultures, a more interactive and experiential approach for developing empathy was in operation at one school where students were physically interacting with students living in poverty:

*We have a long standing relationship with an Aboriginal community ... so that's just that opportunity for students to go and experience, even within our own country, a very different culture, a very different way of living. And I think those opportunities for students to actually experience, get themselves out of their comfort zones and understand ... that there are different ... people living in very different environments to the ones that we're used to. I think that's important in terms of embodying empathy. (Head of Middle School)*

The effort of schools to engender empathy in their students however, may have been hampered by facets of student development. As one participant stated:

*... but of course 15 year olds sometimes aren't particularly empathetic. Their world, it still pretty well finishes at the point of their nose. (Principal)*

## **Balance**

Balance also plays an important role in the IB MYP programme; not only through emphasising a broad and balanced curriculum, and promoting the principle of concurrency of learning, but also by emphasizing the development of the whole person. This consideration of “balance” has the potential to interact with student well-being. The IB MYP aims to assist the development of individuals’ affective, cognitive, creative and

physical capacities. These capabilities may be cultivated through approaches to learning (ATL) that help students better understand how to process information, learn and think effectively, and manage their emotions. As such several inter-related factors may be involved in achieving a sense of balance. This may include participation in extracurricular activities in order to achieve a balance between intellectual, physical and recreational pursuits. There is ample research showing the benefits of involvement in non-academic activities, including greater school connectedness, academic achievement and aspirations, a decrease in risky behaviours such as drug and alcohol use (Darling Caldwell, & Smith, 2005; Dotterer, McHale, & Crouter, 2007; Eccles & Barber, 1999; Fredricks & Eccles, 2008) and the development of a more positive sense of self (Fredericks & Eccles, 2006; Gadbois & Bowker, 2007). Furthermore, striving to “achieve personal well-being for themselves and others” (as stated for this attribute in Table 8) may be linked to being caring and helpful, having a communal orientation and perhaps volunteering, as well as having good nutrition, obtaining sufficient sleep and seeking medical attention when needed.

In an attempt to interpret the concept of “balance” for the purposes of the present study, we determined that “balanced” individuals would exhibit positive self-regard or self-concept, and would feel good about themselves. Since “the term self-concept refers to a person’s self-perceptions formed through their experience and interpretation of their environment” (Scalas & Marsh, 2011, p.1), we reasoned that a person with “intellectual, physical and emotional balance” would have positive self-perceptions of self and would be less likely to exhibit emotional problems or ill-being. Although not originally formulated for this purpose by Marsh (1990), we reviewed the items used in Marsh’s Self-Description Questionnaire, (which measures global self-concept) and determined that this questionnaire would be useful to our present study as a proxy measure for personal “intellectual, physical and emotional balance”.

## **Global Self-concept**

Students completed Marsh’s (1990) Global Self-concept Scale included in the WBQ. A CFA of the scale was undertaken. Marsh’s original model did not fit our data well, but after some trimming a good fitting model was attained (see Appendix B Figure 8). A global self-concept latent variable was determined based on the weighted contribution of the various items in the trimmed scale and an overall global self-concept score was calculated for each student. An examination of these scores found that more than half (61.0%) IB MYP students reported a positive sense of global self-concept “always” or “most of the time” (see Figure 34).

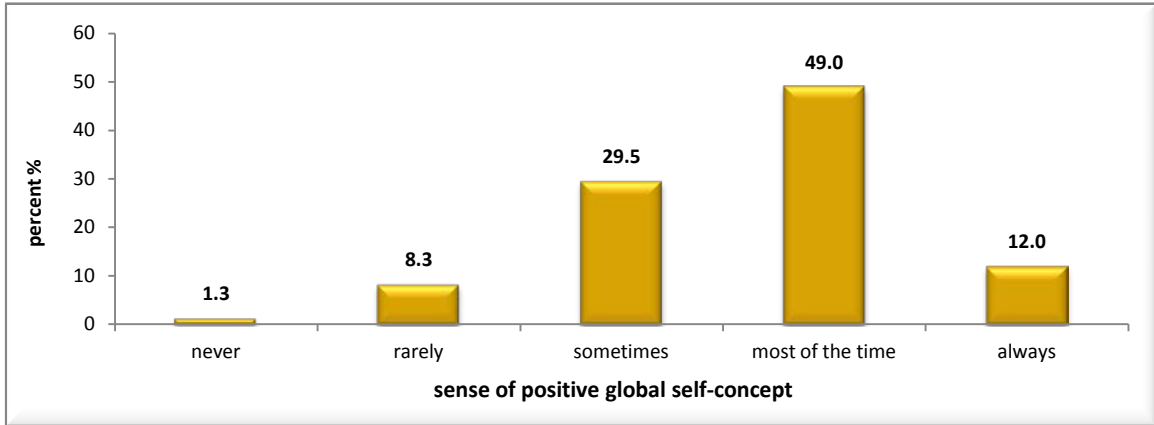

Figure 34 Sense of a positive global self-concept of IB MYP students

Males generally had higher global self-concept scores than females (Mann-Whitney U,  $Z = -5.6$ ,  $p < .000$ ,  $E.S.(r) = 0.13$ ), although the effect size of this difference was small. As shown in Figure 35, over two-thirds (67.8%) of males compared to just over half (54.0%) of females, reported that they had a sense of a positive global self-concept “most of the time” or “always”.

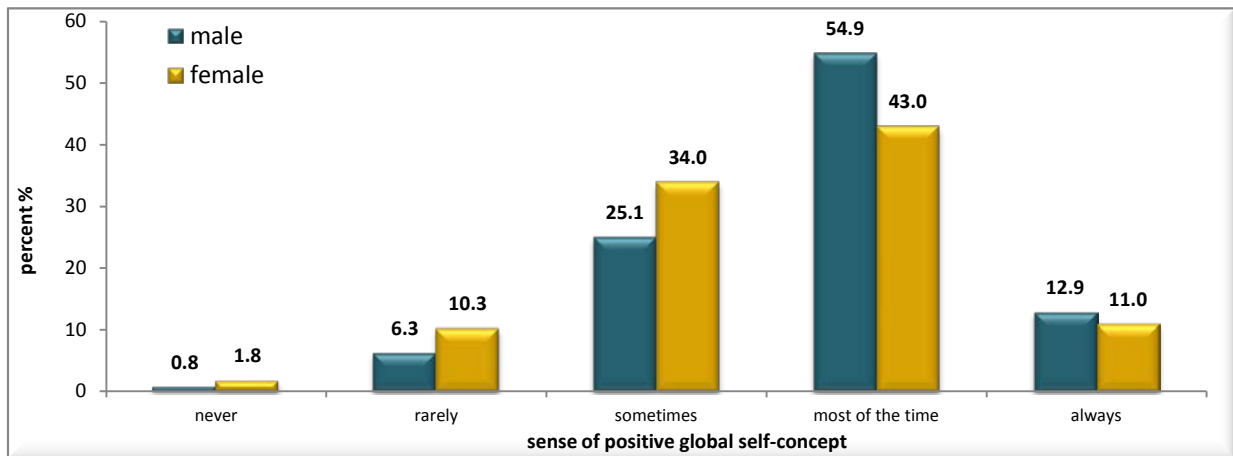

Figure 35 Sense of a positive global self-concept of male and female IB MYP students

## Global Self-concept by Gender and Year Level

The global self-concept of males and females across different year levels were analysed and an interaction effect of gender and year level was found ( $F(4) = 7.8$ ,  $p < .000$ ). Lower year levels and particularly females, were more likely to have higher global self-concept scores than upper year levels. Females in Years 9 and 10 were more likely to have lower global self-concept scores than males (see Figure 36).

A MIMIC model was undertaken to examine the influence of variables such as gender, age, year level, school and SES on global self-concept scores. In that analysis, SES and an interaction effect of gender and year level were found to be associated with global self-concept (see Appendix B Figure 9) while the other variables were not significant. Females in the upper year levels were less likely to have a positive sense of global self-concept, while the opposite was true of young people with high SES backgrounds. However, these factors were associated with less than 10 percent (9.8%) of the variance in global self-concept scores, so were of minor influence.

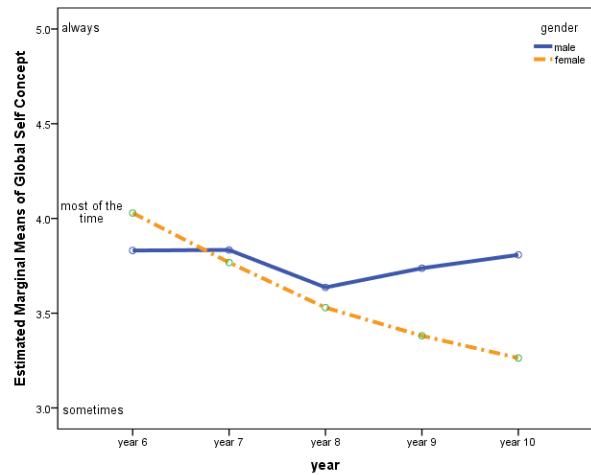
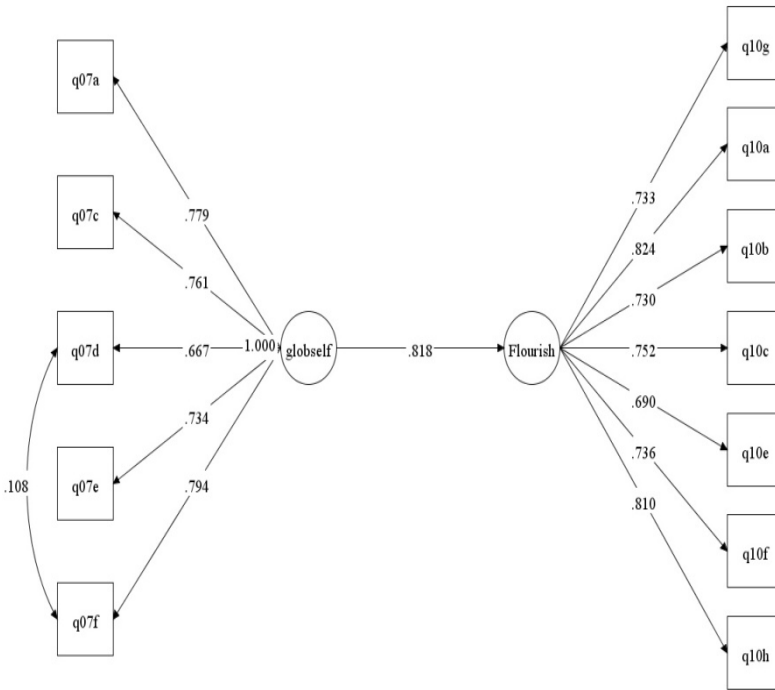

Figure 36 Mean global self-concept scores of male and female IB MYP students by year level

## Global Self-concept and Well-being

The association of global self-concept with well-being was examined by using the global self-concept model (see Appendix B Figure 8) in SEM regression analyses with each of the well-being measures used in our study i.e. FloS, MentHC and StirCWB. The global self-concept factor was found to be a significant predictor of well-being in all three well-being measures. As shown in Figure 37 (a), Global self-concept was a significant predictor of flourishing and it was associated with just over two thirds (66.9%) of the variance in FloS scores. This suggested that students with high levels of global self-concept were the most likely to be flourishing. Similarly, global self-concept was a significant predictor of the components of well-being comprising the MentHC. As Figure 37 (b) shows, global self-concept significantly predicted emotional, psychological and social well-being, accounting for over one third of the variance in each of these factors (45.3%, 36.6% and 52.8% respectively) in the MentHC. The analysis suggests that global self-concept may be an important element in social well-being since it is associated with just over half (52.8%) of the variance in social well-being scores. In a similar vein, global self-concept was strongly associated with positive outlook. Finally, as shown in Figure 37 (c), global self-concept accounted for just under 80 percent (79.3%) of the variance in positive outlook scores and just under half (49.6%) of the variance in positive emotional state scores in the StirCWB.

(a) Global Self-concept and FloS



$\chi^2 (52) = 300.9, p < .000$   
 RMSEA: 0.051  
 90% C.I.: 0.045 – 0.056  
 Probability RMSEA < .05: 0.420  
 CFI: 0.969  
 TLI: 0.961  
 SRMR: 0.030  
  
 $R^2$  (Flourish): 66.9%

(b) Global Self-concept and MentHC

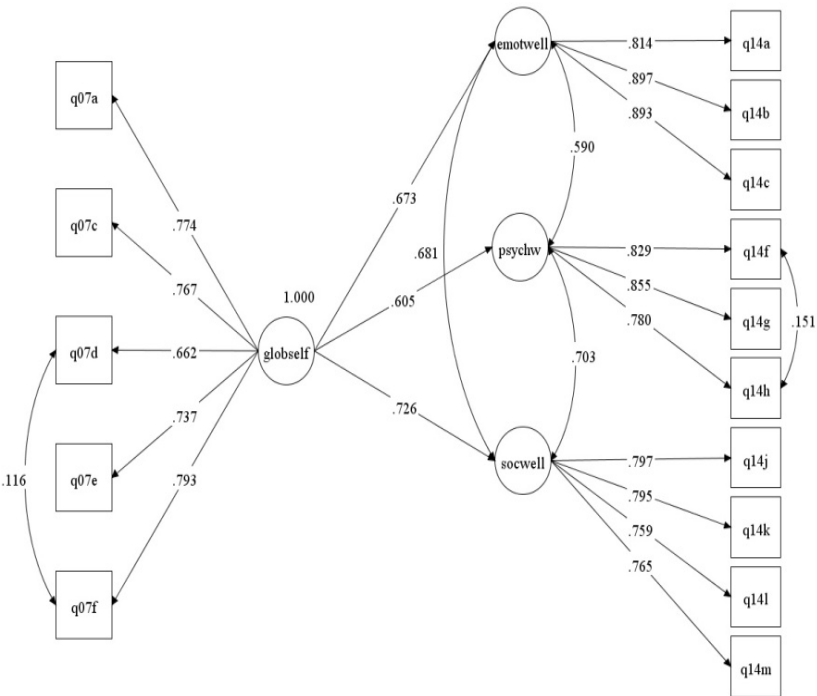

$\chi^2 (82) = 353.7, p < .000$   
 RMSEA: 0.042  
 90% C.I.: 0.038 – 0.047  
 Probability RMSEA < .05: 0.998  
 CFI: 0.979  
 TLI: 0.973  
 SRMR: 0.025  
  
 $R^2$  (Emotional Well-being): 45.3%  
 $R^2$  (Psychological Well-being): 36.6%  
 $R^2$  (Social Well-being): 52.8%



(c) Global Self-concept and StirCWB

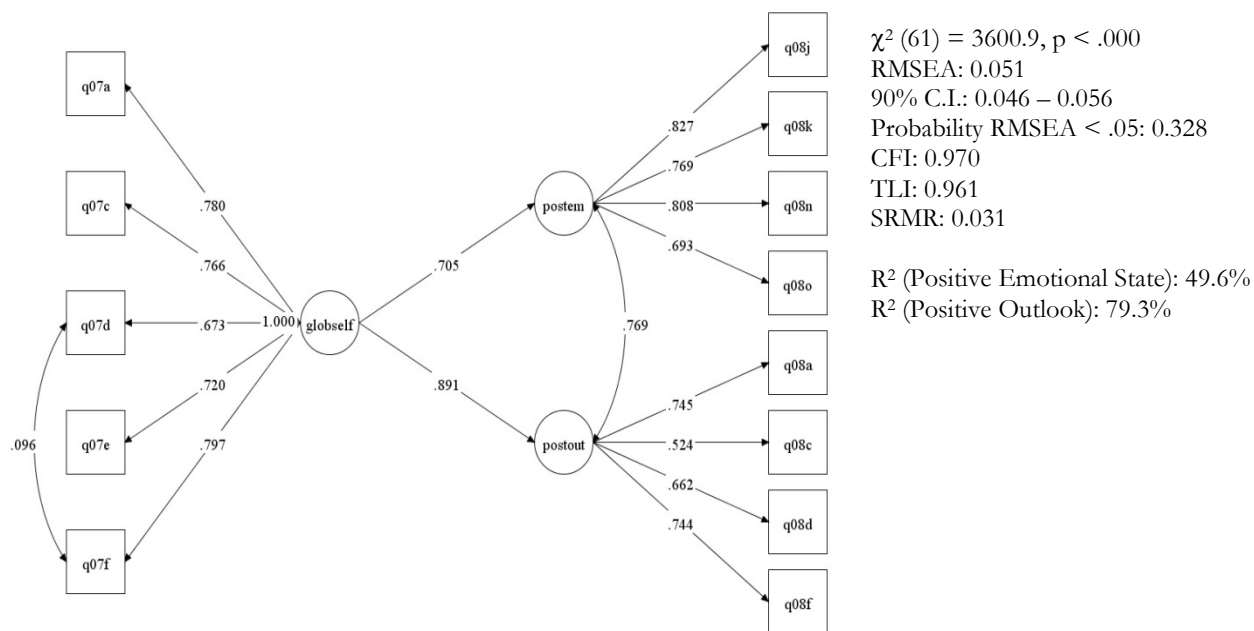

Figure 37 Global self-concept as a predictor of well-being

## Building Students' Self-concept

The qualitative study found that schools actively seek to assist students with their global self-concept. Staff members described several approaches that were used by schools to build the global self-concept of students, including the following:

*We've got a lot of outside agencies that like to come and work with our students ... for example we've got the Uniting Care Wesley coming next term to work with a group of boys in Year8, that we feel are perhaps lacking in self-esteem and some confidence. (Well-being Coordinator)*

*We had issues with certain Year nine and 10 girls - just self-esteem, so we put together a group for that, which Youth Connection was able to come in and run for them and that went for about six or seven weeks with about 10 girls. (Counsellor)*

However, as one participant stated in the quote below, building a student's self-concept is influenced by many factors that run counter to their efforts to assist students.

*It is I think difficult in terms of getting them to have that confidence to believe in themselves when sometimes others don't believe in them. (Well-being Coordinator)*

Enabling students to believe in themselves, according to staff at one school, involves a persistent team effort.

The key is:

*... a great team. Supporting each other, classroom teacher, counsellor, head of school, office administration all on board, all supporting, all talking. It couldn't happen without that ... and being persistent and consistent ... we do take it as a whole school approach, it's not a teacher-by-teacher individual thing, it's something that we all do together as a team. (Well-being Coordinator and Counsellor)*

## Reflection

Reflection is an explicit part of the objectives in all IB MYP subjects and it is a key skill area that is taught through approaches to learning (ATL). Students are taught how to reflect, when to reflect, different ways to reflect and the value of reflection. The important role of self-reflection and insight was highlighted by Grant, Franklin and Langford (2002) in their model of self-regulation and goal attainment. The inspection and evaluation of one's thoughts, feelings and behaviour, provides insight and understanding. Self-Reflection, they suggested, is a metacognitive factor that is key to the process of purposeful and directed change. By following a cycle of reflection, individuals monitor and evaluate their progress and use insight to improve their performance. Reflection is another element of the IB Learner Profile that is potentially associated with well-being.

Researchers have identified two types of reflection, distinguished by the level of self-absorption. The first, rumination, where there is a tendency to repeatedly focus on the self, is characterised by neurotic propensities. This differs from the second type, a healthier internal reflection, which promotes insight and self-acceptance (Harrington & Loffredo, 2010). The former type, self-reflection, has been linked to depression and negative affect (Mor & Winquist, 2002) while the latter type of self-reflection with insight is associated with psychological well-being (Harrington & Loffredo, 2010; Lyke, 2009).

Practices of self-reflection by IB MYP students and the connection to social, emotional and psychological well-being were investigated in our study using one subscale of the Self-Reflection and Insight Scale (SRIS; Grant et al., 2002), which was developed in Australia. The Self-Reflection subscale was used to determine how the self-reflective practices of young people linked to their social and emotional well-being.

## Self-Reflection

Students completed items of the Self-Reflection subscale of Grant et al.'s (2002) SRIS Scale, which a confirmatory factor analysis found fit our data well (see Appendix B Figure 10) and showed good reliability (Coeff H = 0.9). Factor score coefficients were used to calculate a self-reflection (latent variable) score for each student. When students' self-reflection scores were examined, nearly three-quarters (74.6%) indicated

that they were engaging in self-reflection, having agreed with items such as “I often spend time in self-reflection and “I frequently examine (think about) my feelings” (see Figure 38).

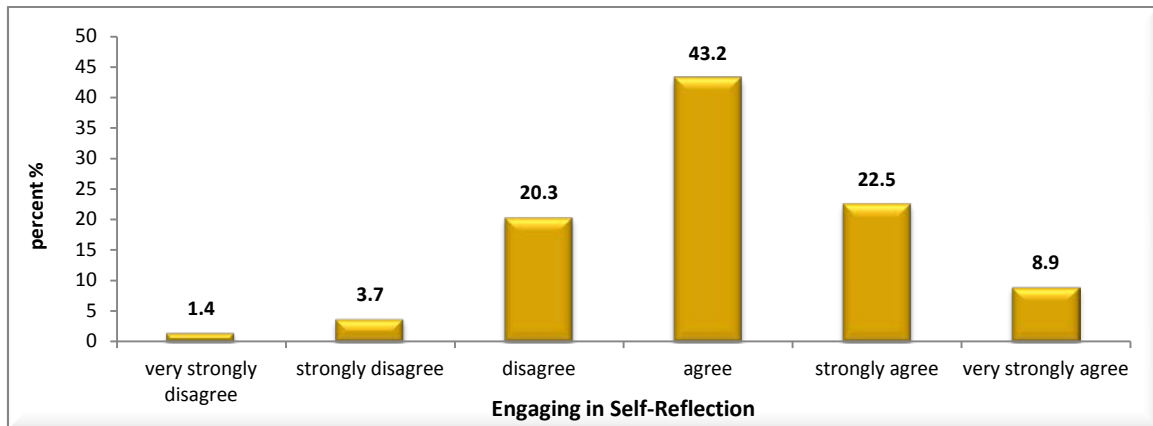

Figure 38 Engagement in self-reflection by IB MYP students

### Self-Reflection by Gender and Year Level

A comparison of gender and year level scores (controlling for SES and school) suggested that females were more self-reflective than males ( $F(1) = 25.4, p < .000, E.S.(r) = 0.12$ ), while students in the upper years of MYP were more self-reflective than the lower years ( $F(4) = 3.3, p < .05$  - see Figure 39). However, there was no interaction effect of gender and year level.

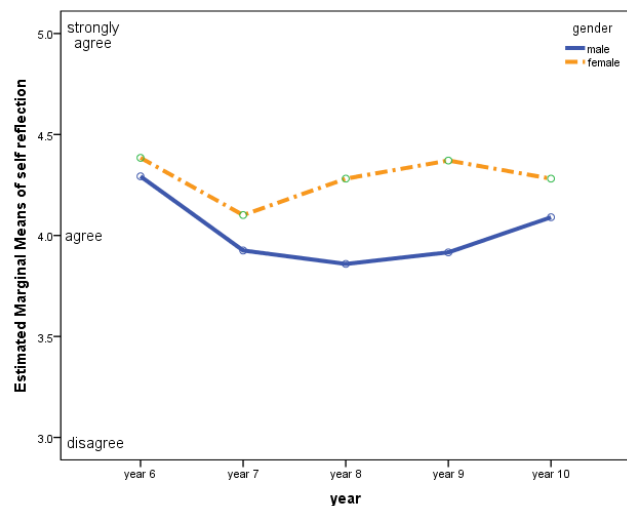

Figure 39 Mean self-reflection scores of male and female IB MYP students by year level

### Self-Reflection and Well-being

Students’ scores on the self-reflection scale were used in regression SEMs to examine the relationship of self-reflection with all three well-being measures used in our study (described in chapters 3-5). Self-reflection was found to be a very poor predictor of all three well-being measures. As shown in Figure 40 (a) – (c), Self-Reflection was associated with 5% or less of the variance in measures of well-being including FloS (5%), emotional well-being (1.2%), psychological well-being (0.9%), social well-being (4.2%), positive emotional

state (1.9%) and positive outlook (2.4%). These findings suggest that self-reflection does not significantly influence well-being.

(a) Self-Reflection and FloS

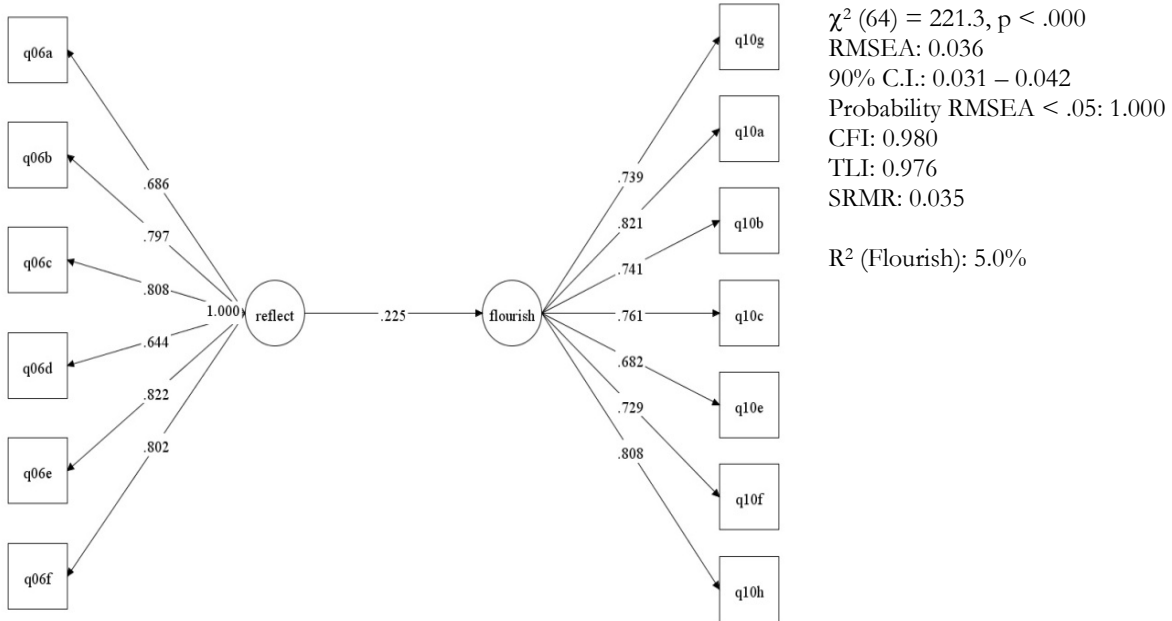

(b) Self-Reflection and MentHC

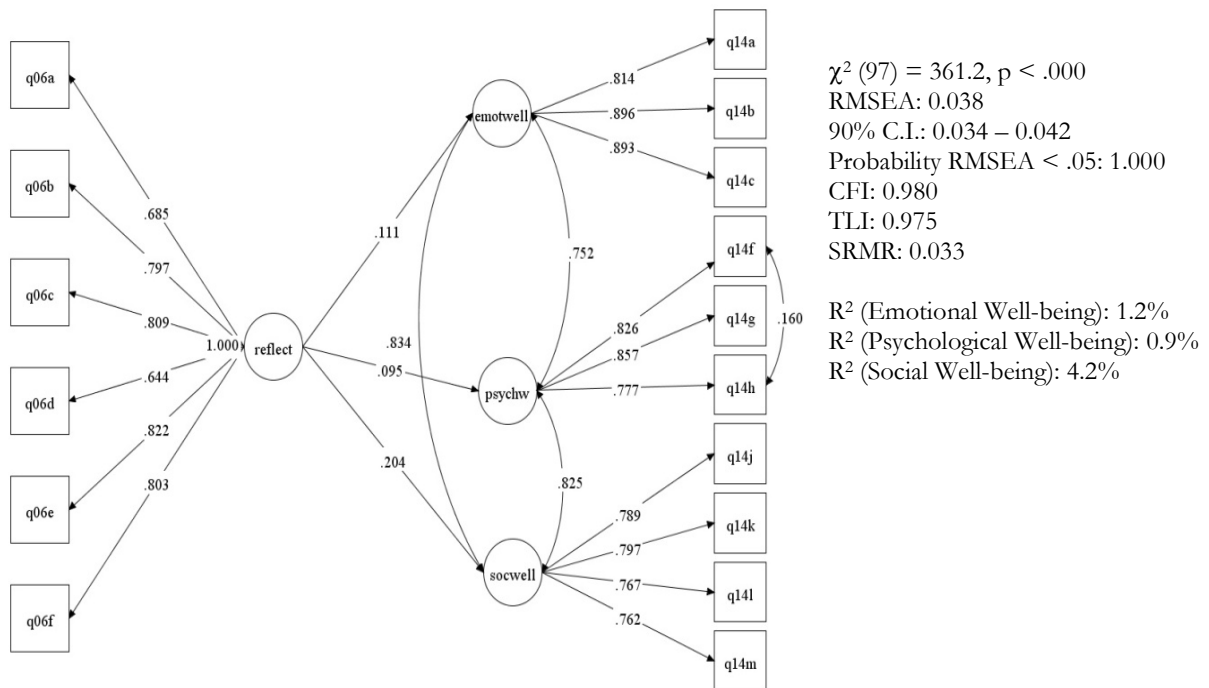

(c) Self-Reflection and StirCWB

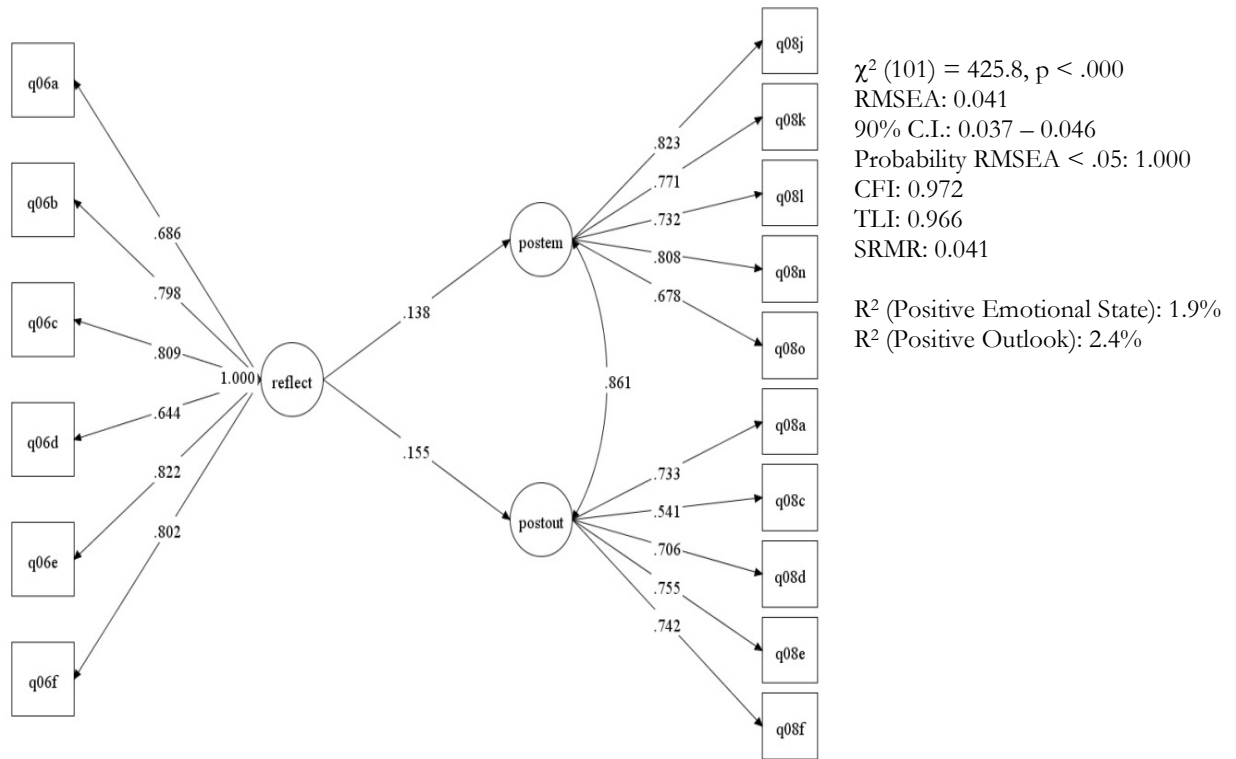

Figure 40 Self-Reflection as a predictor of well-being

## Students' Views about Self-Reflection

Students in the focus groups provided details about how self-reflection was being used by them at school. Some stated that they were asked to self-reflect regularly by teachers during the year about their learning:

*The main thing that we reflect on like in heaps of subjects that they tell you like for the reflection part is that they always ask you what you could do better next time and then they also ask something like, "How do you think you did?" or like what could - yes, they ask a lot of questions, but it's not just in maths and like in inquiry I think we also did it in ... a lot of other subjects as well. (Female, Year 8)*

*At the end of each term we get given a piece of paper to reflect on your goals. (Male, Year 7)*

*We have to reflect, like, what we've done and what we like or what we could have changed with our assignments. (Female, Year 7)*

*When we do stuff in humanities, especially in the junior school after we do a project we have to do this reflection thing like, "Did you enjoy this, what do you think you could do better?" (Female, Year 8)*

However, some students did not like self-reflecting and some felt that the reflective practice wasn't being used effectively:

*Self-appraises are probably the - yes, they're probably the most annoying because they don't - like the way the school's written it out is the teachers just tick whether they agree or not ... we'd like a bit more input than that, like a bit more information from them. (Female, Year 10)*

*I don't find that is really relevant to what we're doing. I don't think a reflection really makes any difference. (Male, Year 7)*

*... because it's just a waste of time. We can reflect on our own. We don't need to write it out. (Male, Year 10)*

There was also a hint that in addition to school work, students were reflective about other things, although it was not clear whether being reflective involved rumination or was insightful and beneficial, as the following quote indicates.

*You think about the things they [friends] say about you and maybe some things are true so you might want to improve on some things they mentioned. (Female, Year 10)*

Harrington and Loffredo (2007) have suggested that reflection which is used insightfully to promote personal growth and self-acceptance is healthier than reflection which is self-critical and disparaging. As the response in Figure 41 shows, unhealthy reflection can have a negative effect. To be the most effective and to promote well-being, reflection should be insightful. IB MYP students might benefit from better instruction to assist them to engage in more positive and productive reflective practices.

D5. Describe with words or with a drawing how your school helps you to be successful.

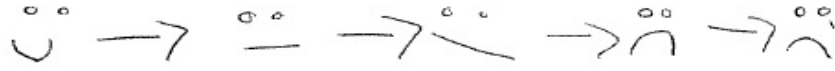

Over thinking life gets me worked  
up and I just cry!

Year 9 Female 15

Figure 41

Comment made by a female IB MYP student about reflection

## Resilience

While not explicitly listed as part of the IB learner profile, resilience is an affective and cognitive skill inherent in the IB MYP that seeks to advance a self-regulated learner to effectively deal with and respond positively to any setbacks and difficulties, and to make changes and persevere (IBO, 2013). Connor and Davidson (2003) described resilience as a concept where personal qualities operate to enable one to thrive in adverse conditions and which, when functional, may improve both physical and mental health. Campbell-Sills and Stein (2007) noted that while negative affect is a common outcome for childhood maltreatment, such as depression and substance use, “not all maltreated children go on to manifest such problems and those children have been classified as ‘resilient’” (p. 1020). Fredrickson (2001) hypothesised that the effect of positive emotions on resilience is that they broaden the “thought action repertoires” that are available to individuals when they are under stress.

Studies have shown that resilience is positively correlated with factors associated with positive affect (Bonanno 2004; Luthar, Cicchetti, & Becker, 2000; Tugade & Fredrickson 2004) and with life satisfaction (Wagnild & Young, 1993; Yu & Zhang, 2007), suggesting that resilience plays a part in psychological well-being in the presence of environmental stressors (Vaishnavia, Connor, & Davidson, 2007). A shortened version of the Connor-Davidson Resilience Scale (CD-RISC) modified by Campbell-Sills and Stein (2007) was used in our study to examine the resilience level of IB MYP students and its association with well-being.

## Resilience Scores

IB MYP students completed the 10 items that comprise the CD-RISC in the WBQ. A total resilience score was calculated for each student by summing responses to each of the items. Total resilience scores ranged from 0-40; the mean was 25.3 (S.D. = 7.3). This mean was found to be comparable (within one standard deviation) of the mean resilience score obtained by Lim et al. (2011) of 190 adolescents, aged 12-16, from a public mainstream secondary school in Singapore.

A Confirmatory factor analysis found that the scale fit our data well, and had good reliability, after one item was dropped (see Appendix B Figure 11). Factor score coefficients were used to calculate a resilience (latent variable) score for each student. Further analysis of resilience scores found that just over half (53.3%) of IB MYP students reported that they felt resilient “often” or “nearly all the time” (see Figure 42).



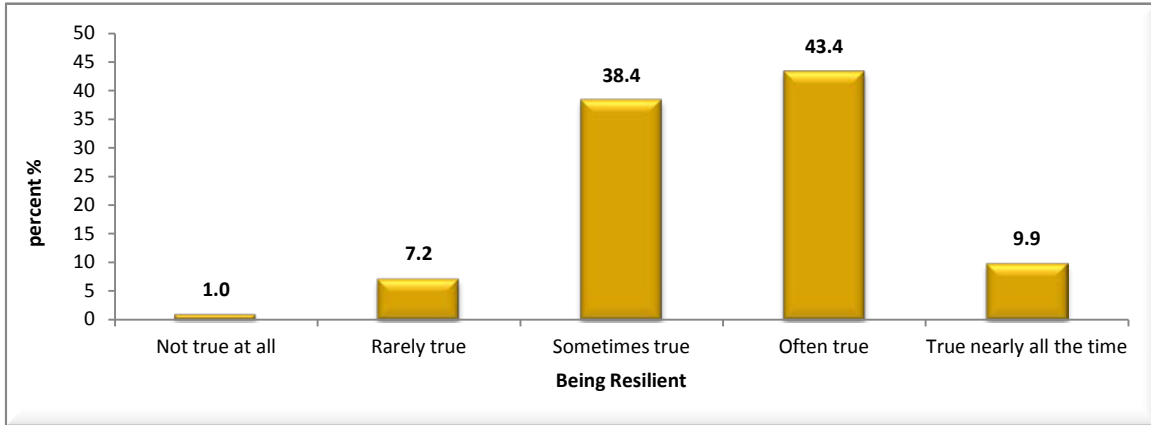

Figure 42 Incidence of being resilient of IB MYP students

### Resilience by Gender and Year Level

When students' resilience scores were analysed controlling for SES and school, males were found to be more resilient than females and resilience decreased across year levels, particularly for females ( $F(4) = 7.4, p < .000$ ), although it began to increase for males during Year10 (see Figure 43).

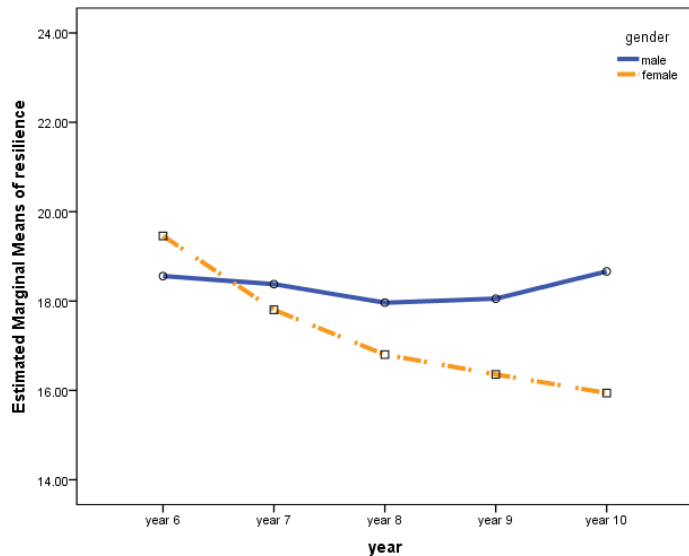
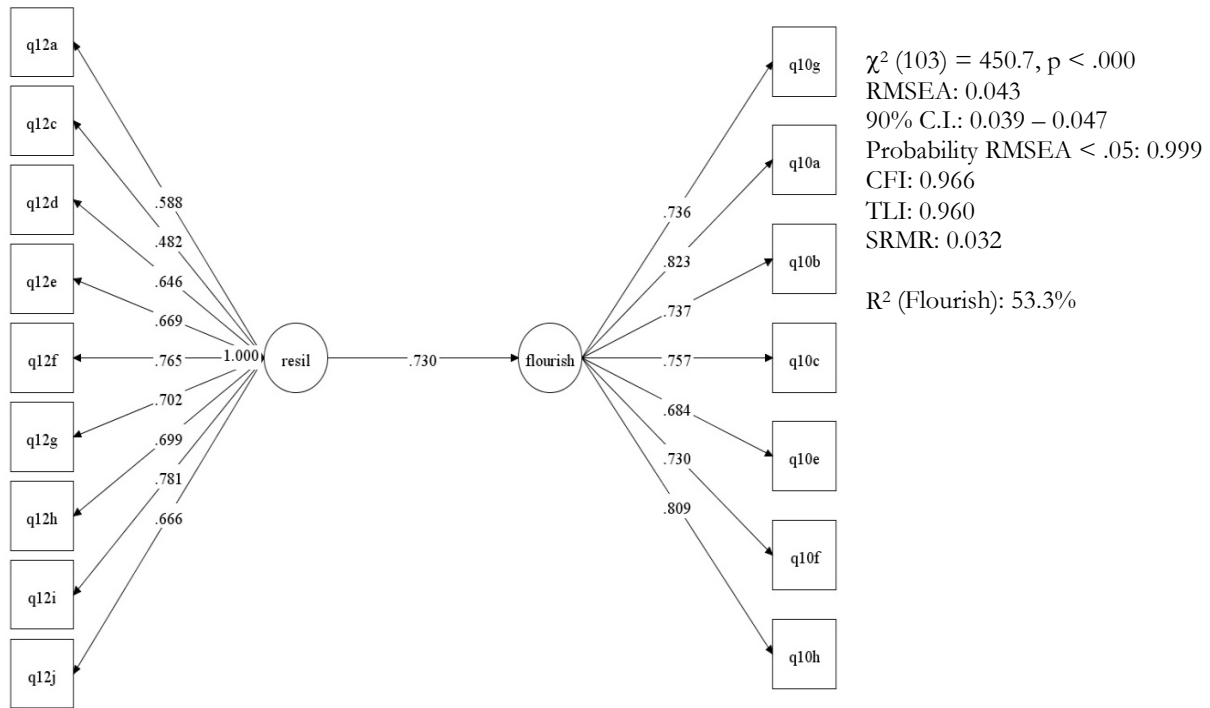

Figure 43 Mean resilience scores of male and female IB MYP students by year level

### Resilience and Well-being

The Resilience latent variable was regressed in a SEM on all three well-being measures used in our study i.e. on FloS, MentHC and StirCWB, (see Figure 44(a) – (c)). The results show that resilience was a very good predictor of well-being and was associated with over half of the variance of flourishing (53.3%), social well-being (55.0%) and positive outlook (56.6%), just under half of the variance of emotional well-being (43.0%) and a positive emotional state (48.1%), and just under one third of the variance of psychological well-being (30.5%).

(a) Resilience and FloS



(b) Resilience and MentHC

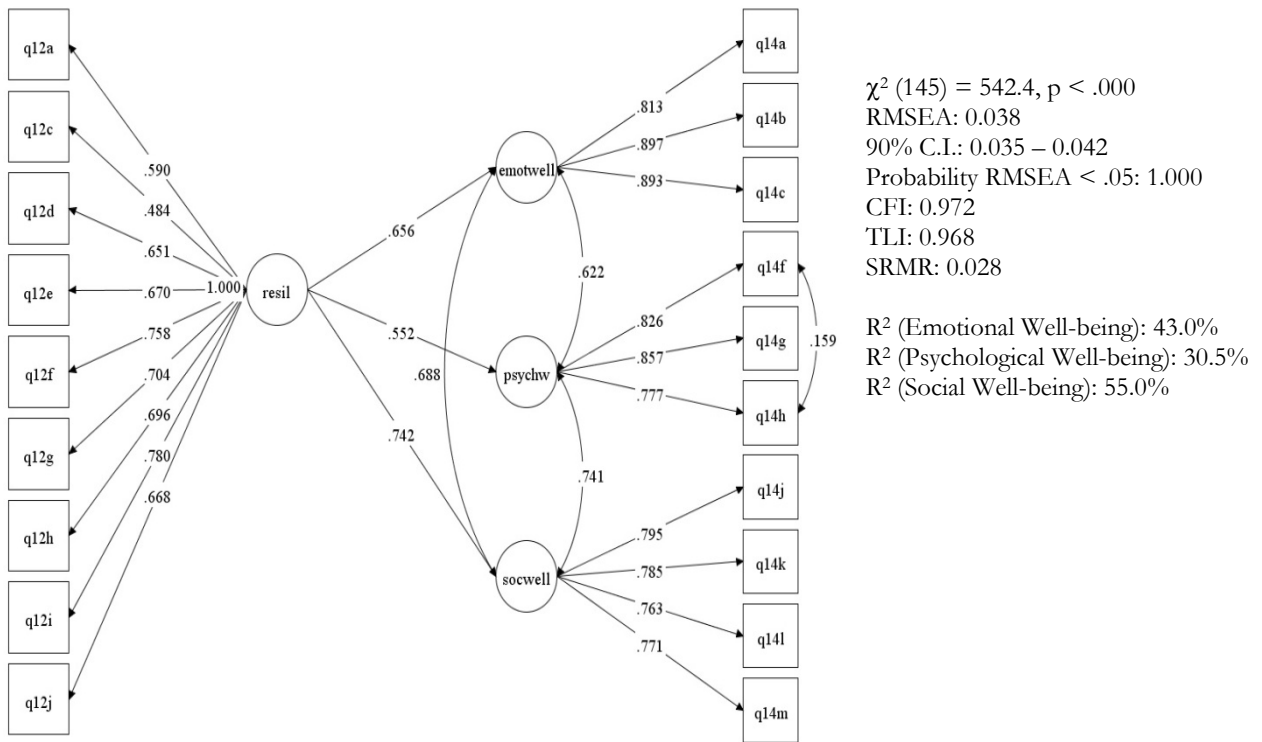

(c) Resilience and StirCWB

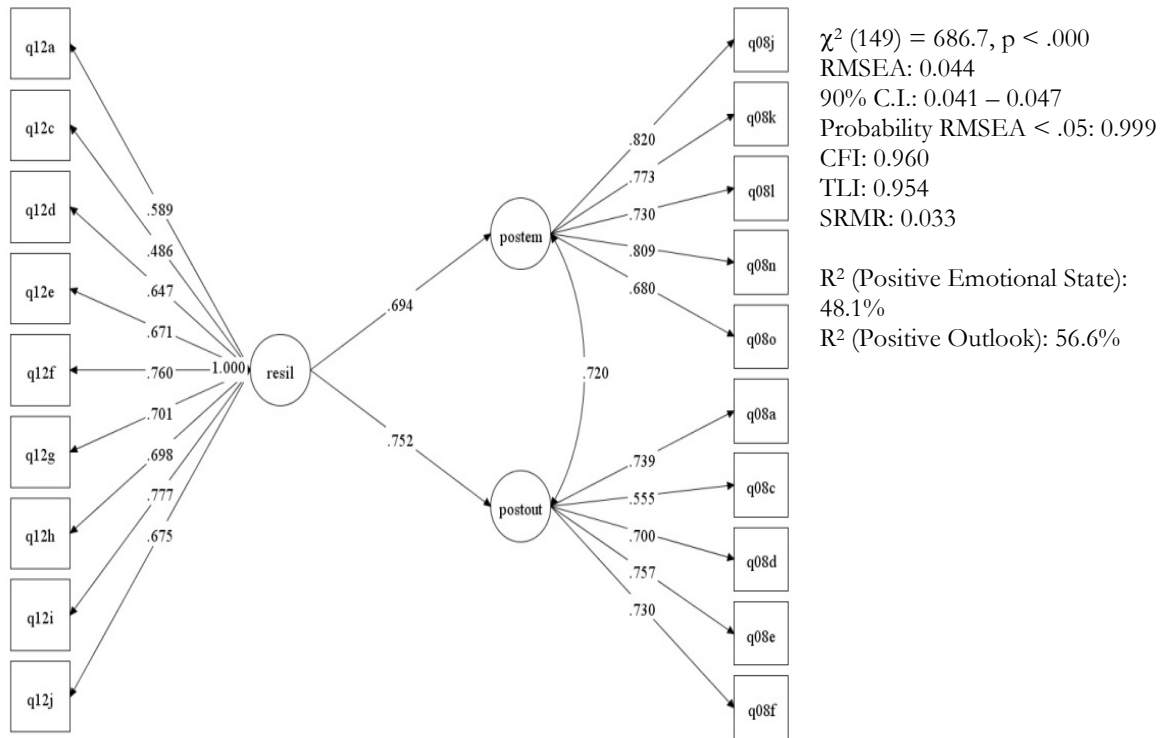

Figure 44 Resilience as a predictor of well-being

## Relationships

Personal relationships have been noted to be of great importance for well-being. Diener and Seligman (2002) found that close personal relationships with others had a profound impact on well-being and significantly contributed to happiness. Although well-being is frequently considered to be a result of good relationships and having friends, Oberle, Schonert-Reichl and Thomson (2010) pointed out that it is important to recognise the bidirectional nature of this association, as well-being impacts on social status and social status impacts on well-being simultaneously. The value of good positive relationships and the impact on well-being is well documented in the literature (e.g., Gibb, 2003; Lyubomirsky, Sheldon, & Schkade, 2005; Nangle & Erdley, 2001; Rubin, Bukowski, & Parker, 2006; Wentzel, 2009).

There has been a multitude of research examining the negative aspects of peer relationships such as bullying and peer rejection, and their associated consequences, including poor psycho-social adjustment and behavioural problems (e.g., Dijkstra, Lindenberg, & Veenstra, 2007; Gazelle & Druhen 2009; Georgiou & Stavrinides 2008; Mercer & DeRosier 2008; Nesdale & Lambert 2007; Trentacosta & Shaw 2009) but more recently a positive psychology paradigm has emerged amongst researchers. This approach emphasises the study of positive features of human development such as, “subjective well-being, optimism, happiness, and self-determination” (Seligman & Csikszentmihalyi, 2000, p. 9) and “the manifest potentialities rather than the supposed incapacities of young people...” (Damon, 2004, p. 15).

Our study examined relationships and positive aspects of child and adolescent development, and their connections to social and emotional well-being, using a combination of three subscales, the pro-social subscale that forms part of the Peer Relations Questionnaire (Rigby & Slee, 1991), the peer-problems and pro-social subscales that form part off the Strengths and Difficulties Questionnaire (SDQ, Goodman, 1997) and the school relations subscale of the school satisfaction questionnaire (Longitudinal Study of Australian Children, LSAC). Items from these questionnaires were combined to obtain a group of questions that could be used for a measure “relationships”.

## Relationship Model

By combining the items from the subscales referred to above, it was possible to develop a construct with indicators for a “relationship” latent variable. The latent variable measuring relationships comprised nine questions (see Table 8). A CFA found that the nine items were good indicators of a relationships construct with three factors of school relationships, positive relationships and friends, as shown in Table 8, and that had good reliability and fit the data well (see Appendix B Figure 12).

**Table 8 Factors and indicators of the relationship latent variable**

Relationship Factors	Item
School Relations	At school I participate with anyone or any group.
	I have a sense of togetherness with the other students in my class.
	At school I feel that I really belong.
	My teachers always find time to talk to students.
ProSocial	I try to be nice to people. I care about their feelings.
	I enjoy helping others.
	I often volunteer to help others (parents, teachers, children).
	I like to help people who are being harassed.
	I want to help people who get treated badly.
	I sometimes try to understand my friends better by imagining myself in their position.
	I am helpful if someone is hurt, upset or feeling ill.
Friends	I have one good friend or more.
	Other people my age generally like me.
	I get along with other students.

Factor score coefficients derived from the CFA analysis were used to calculate a relationship score for each student. Scores ranged from 7 to 29 with a mean of 20.7 (S.D. = 4.0). As shown in Figure 45, the relationship variable was skewed.

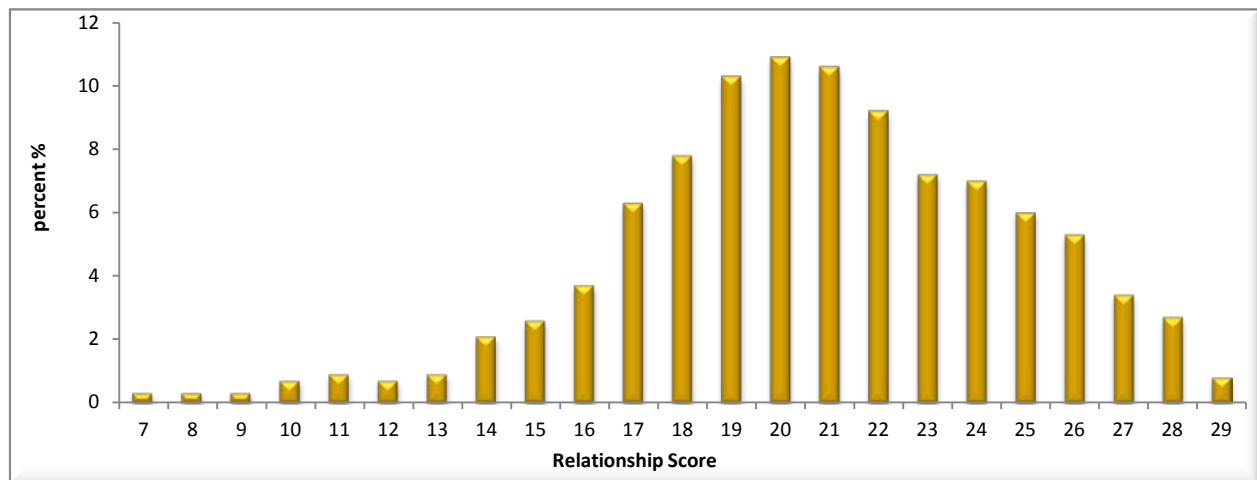

**Figure 45 Relationship Scores of IB MYP Students**

It was not possible to derive meaningful scores of the relationship latent variable as items included in this measure involved different scales. For example, items in the school relationships factor were on a 7-point

Likert scale ranging from “very strongly disagree” to “very strongly agree”, while items in the other factors were measured using 3- and 4-point scales with different anchors (see Appendix A Table 8).

## Relationships by Gender and Year Level

Nonparametric tests suggested that there were no significant differences between males and females in terms of their relationship scores. However, controlling for SES and school, there was a significant interaction of gender and year level with relationships ( $F(4) = 5.8, p < .000$ ). As seen in Figure 46, relationship scores decreased from Year 7 to Year 8 for males and from Year 7 to Year 9 for females. The findings suggest that females’ relationships were strained during Year 9, while males appear to have had a similar experience during Year 8. Relationships appeared to have been improving during Year 10 for both males and females, although they were not generally at the same level that they were in Year 6, when relationships were at their best.

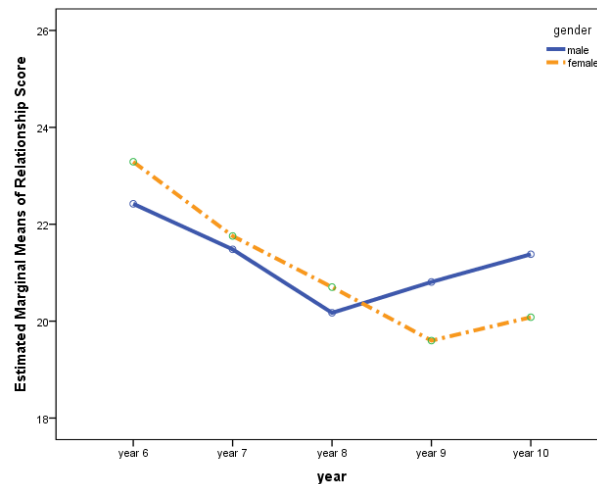
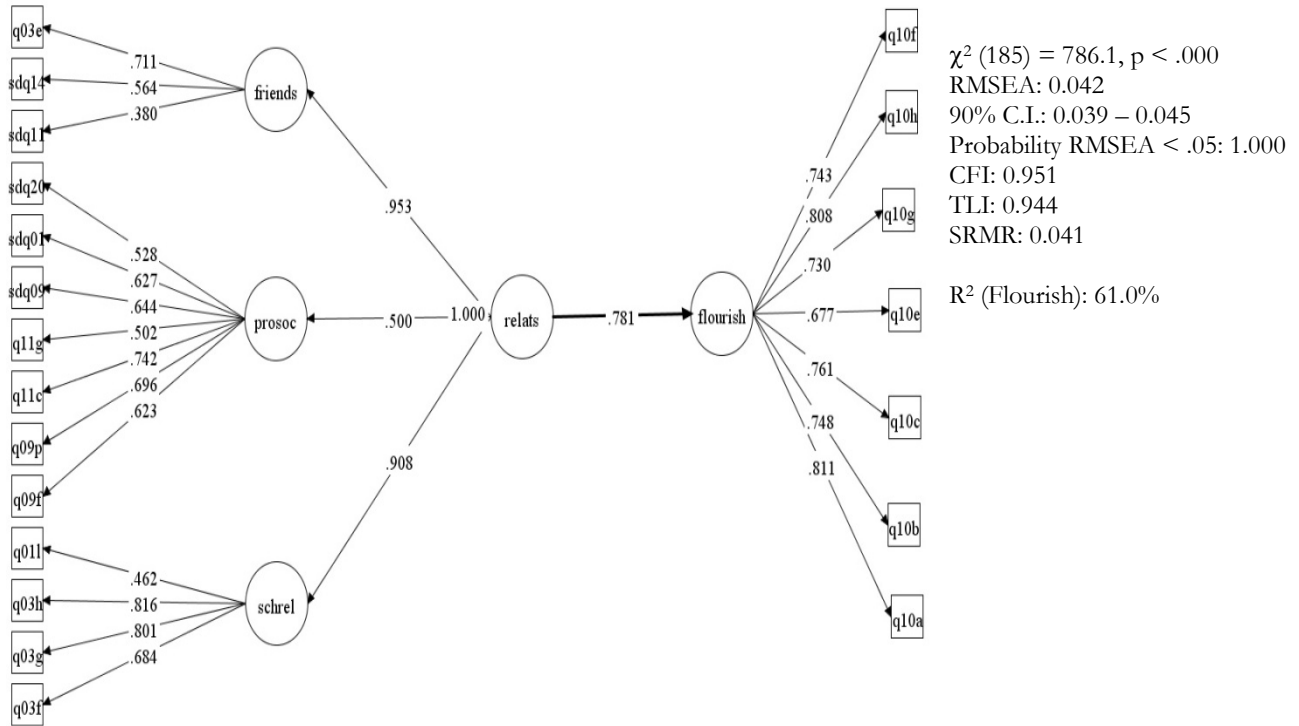

Figure 46 Mean relationship scores of male and female IB MYP students by year level

## Relationships and Well-being

A SEM regression analysis found that the relationship factor was a significant predictor of well-being, as measured by FloS, MentHC, and StirCWB. As the analyses presented in Figure 47 (a) – (c) show, relationships were associated with large amounts of variance in flourishing (61.0%), emotional well-being (42.3%), psychological well-being (41.5%), social well-being (51.6%), positive emotional state (59.1%) and positive outlook (57.8%). The findings suggest that friendships, being pro-social as well as positive relationships at school are important factors for well-being.

(a) Relationships and FloS



(b) Relationships and MentHC

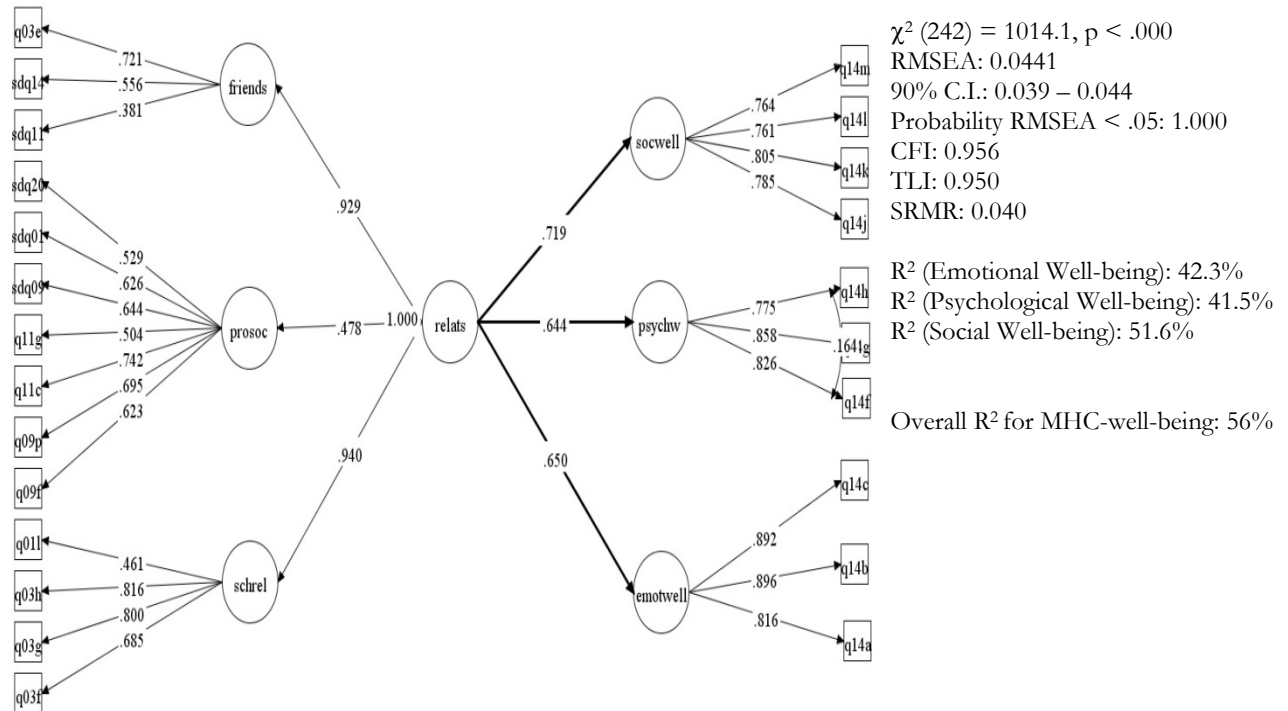

(c) Relationships and StirCWB

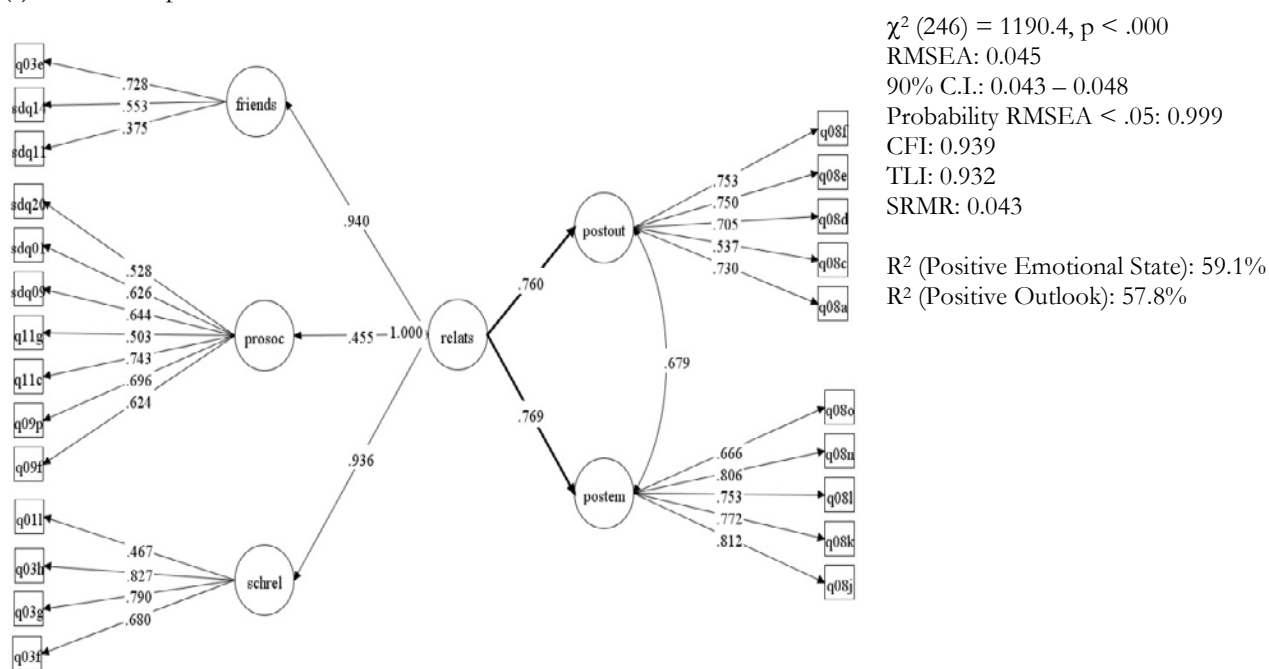

Figure 47 The Relationship factor as a predictor of well-being

## Students' Views about Relationships at School

### Peer Relationships

The qualitative data provided some insights about student relationships at school. Students' seemed to comprehend the link between friendships and well-being. In one focus group, a group of Year 10 males explained how well-being and having friends were inextricably linked:

*If you've got no friends it's not really enjoyable to come to school. All you're doing is coming to learn. If you've got no one to socialise with then you get bored and just ... sad. You don't learn as much. You don't really want to be here ... you don't concentrate as much ... nothing to look forward to. (Males, 15)*

Friendships have been highlighted by other researchers (Hodges et al. 1999; Prinstein, Boergers, and Vernberg 2001) as important for alleviating psychosocial maladjustment during adolescence. According to these researchers, friends provide validation of aspirations, trepidations and interests, and contribute to a general sense of social acceptance. The following statements from students in the focus groups suggest that students are well aware of the importance of friendships for well-being and also of the bidirectional nature of the link:



*If you're happy with your friends then you're likely to just shake things off, because you're having more fun with your friends than the troubles on your back and things like bullying and stuff ... sometimes you can just shake it off if you're happy enough elsewhere. (Female, Year 8)*

*Friends streamline the process of doing anything at school so maintaining a good relationship is absolutely important to a successful positive approach to school. (Female, Year 9)*

## Student Teacher Relationships

Focus group participants were also cognizant of good student-teacher relationships for their well-being and for their success at school. The following quotes support these views:

*Most teachers will make an effort to be as friendly as possible. It's in most cases, really easy to establish a relationship with them. (Male, Year 9)*

*If you've got a good relationship with your teacher then you enjoy your lesson and therefore you've got, like, a good well-being. (Male, Year 10)*

*The better you get along with the teacher the more you kind of like listen. (Female, Year 10)*

*Kind of like make them proud of you, I guess ... You don't want to disappoint them ... if you have a good relationship with them, then you're going to want to do that work for them and not want to slack off in class. (Female, Year 10)*

The following picture (Figure 48) provided by a Year 10 female in response to the WBQ open-ended question to “describe with words or with a drawing how your school helps you to be successful” is a poignant illustration of the value of a happy connection between peers and teachers/staff for well-being. Her drawing suggests that not only was she aware of the association between relationships and well-being, but also that it was present at her school.

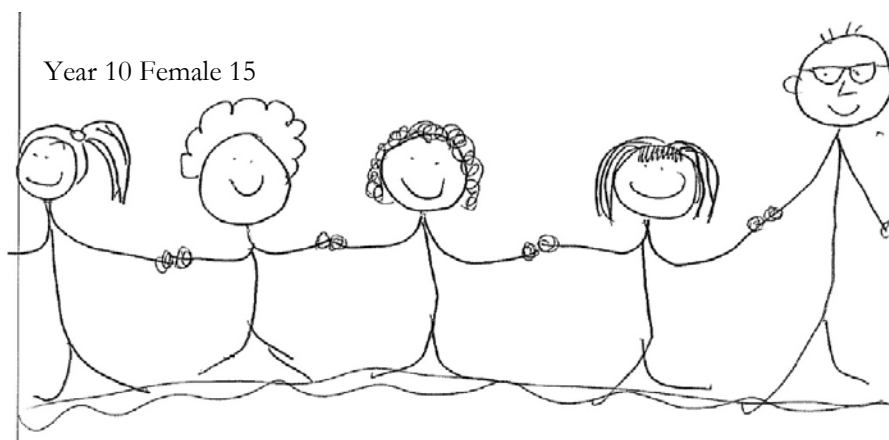

Figure 48 Example of positive school relationships

## Discussion

The findings suggest that schools are making a concerted effort to build caring, empathy, global self-concept, peer relationships, school relationships, self-reflection, resilience and the confidence of IB MYP students.

However, the results have continued to show that males and females differ in the level of attributes they exhibit, for example females have shown higher levels of empathy and self-reflection, but lower global self-concept and resilience than males, although positive experiences of relationships did not differ from males.

The analysis also indicated that global self-concept, relationships and resilience were strongly associated with well-being, while affective empathy and self-reflection were not as strongly correlated with well-being.

## Empathy

Overall, nearly one quarter of IB MYP students indicated high levels of empathy, although affective empathy was present in just over half of the IB MYP students and this was more prevalent than cognitive empathy.

This finding is reassuring, since affective empathy was found to be associated with well-being and cognitive empathy was not. In fact the results suggest that high levels of cognitive empathy promote lower levels of well-being.

In agreement with a study by Eisenberg and Lennon (1983) our study found significant differences in empathy between males and females, with females showing greater levels of cognitive and affective empathy during the middle years. Our findings however, do not concur with findings from a recent study by Van der Graaff, et al. (2013). In their longitudinal study examining empathy in males and females across ages 13-18, they found that cognitive empathy increased for females from ages 13 to 15 and for males after age 15. However, in our study we found that following a decrease after Year 6, cognitive empathy was relatively stable across high school for both males and females. Van der Graaff, et al. also found no significant increase in affective empathy in this age group for females, but a decrease in affective empathy for males. They linked the decrease in affective empathy in males to gender intensification theory (Hill & Lynch, 1983), which suggests a strengthening of gender specific socialisation due to physical and emotional changes associated with puberty. According to this theory, they argued, males would be likely to suppress emotions and feelings of caring as they adhered to stereotypical masculine behaviour. This same theory would suggest the opposite for females as they would comply with socialisation pressures to be caring and empathic. In our study we did not find a decline in affective empathy for males. This could be attributed perhaps to the various strategies and programmes implemented by schools to develop empathy in students. Rather than enhancing cognitive empathy, which according to Van der Graaff et al. is likely as Piaget's last stage of cognitive capacity is reached by adolescents, it could be that the IB's emphasis on caring and service promotes affective empathy

instead. However, further research examining students' empathic dispositions using an experimental design would be needed to substantiate this claim.

## Global Self-concept

In our study of IB MYP students, males showed higher levels of global self-concept than females, particularly in the upper years of MYP. This could be related to (amongst other things) a lack of psycho-social programmes in high school and in particular, in the upper years of MYP. It might be of benefit for schools to consider the possibilities of integrating programmes designed to build self-esteem, confidence and self-concept, for all students in the upper years of MYP, in a manner that corresponds with what is undertaken in the lower years of MYP.

It is important for students to possess positive global self-concept as our results indicated that it was significantly associated with well-being, especially for having a positive outlook and flourishing. Some female students may require support and assistance to maintain confidence and to develop a positive self-assessment of themselves as they transition through puberty. Females may be sensitive to media messages about appearance and behaviour, but based on the focus groups, teachers may play a significant role in countering some of these external influences and boosting the self-esteem and self-concept of female students.

## Reflection

In our study we measured self-reflection and not “insightful reflection” and our results support those by other researchers (Harrington & Loffredo, 2010) that suggest that self-reflection that lacks insight does not promote well-being. Most of the IB MYP students indicated that they regularly engaged in self-reflection and evidence from our qualitative study suggested that the type of reflection students were using was not predominantly positive or insightful. Insightful reflection, according to Harrington and Loffredo, involves maintaining a general internal awareness of feelings and mental processes rather than a repeated focus on the self. They have stressed the importance of using insightful reflection for subjective and psychological well-being and pointed out that it is necessary to distinguish this type of reflection from that which involves self-absorption and rumination. The former is what should be promoted in order to enhance the subjective and psychological well-being of students. Harrington and Loffredo suggest practices such as mindfulness “designed to focus attention in a way that fosters acceptance and a nonjudging perspective regarding one's inner experiences” (p. 52), to increase well-being. A primary element of mindfulness is self-acceptance and it involves having an awareness of one's emotions and feelings and acknowledging that a state of imperfection is acceptable. The reflections used by students at school should be insightful and there should be an emphasis on self-acceptance and a non-judgemental stance for mistakes and shortcomings.

## Resilience

Over half of the IB MYP students exhibited signs of resilience, although males were likely to be more resilient than females and females in the lower years of MYP showed greater resilience than females in the upper years of MYP. Resilience was a very significant predictor of well-being and it was strongly associated with flourishing, social well-being and positive outlook. The more resilient the student, the more likely they were to exhibit these facets of well-being. Resilience involves an ability to recover from adverse events and make healthy adaptations to changes and stressful events (Garmezy, 1991). While building the resilience of IB MYP students was not discussed in the qualitative study, schools may contribute to the resilience of students by allowing them to participate in decisions that involve them. According to Australian researchers Oliver, Collin, Burns, and Nicholas (2006) “One way to foster resilience in young people is through meaningful youth participation” (p. 1). This means providing opportunities for individuals to collaborate in the development of programmes which have purpose and which the young person believes in. In doing so, young people acquire skills through experience rather than instruction (Olsson, Bond, Burns, Vella-Brodrick, & Sawyer, 2003). Based on these propositions it would be possible to promote resilience through school practices which involve students in meaningful decision making and collaborative engagements, such as developing a peer support programme by students for students.

## Relationships

Our findings suggest that relationships are strongly related to well-being. The relationships factor was a strong predictor of flourishing, social well-being and a positive emotional state. The importance of relationships for well-being was also acknowledged by focus group participants. Positive relationships with teachers as well as friends is necessary to validate one’s self-worth as individuals lessen their dependence on parents, develop their own identity and make sense of themselves in the world. It is important that teachers maintain positive relationships with students and do not ignore floundering students. Evidence from the qualitative data suggests that overlooking students may have the effect of diminishing self-esteem, confidence, self-concept and ultimately well-being, particularly for females in the upper years of MYP.



# School Satisfaction

---

friends, work, co-operation



Year 6 Female 11

On average, IB MYP students would spend six hours a day, or almost half of their wakeful week days, attending school, so it is no wonder that the type of school experiences they encounter play a vital role in their well-being. The quality of a student's school life has been identified internationally as a key indicator of a young person's well-being (OECD, 2009; Currie et al., 2012). The benefits of social and emotional learning, such as connections to academic success and engaged learning, the prevention of aggressive behaviour, emotional distress and conduct problems, improved attitudes about self, others and school, and the development of social emotional skills and positive behaviour, have been identified as factors worthy of further examination in well-being studies (Durlak et al., 2011). Tomyne and Cummins, (2011) found school satisfaction to be an important aspect of student subjective well-being and recommended questions including measures of school satisfaction with school behaviour, teachers, abilities and safety in student well-being questionnaires.

Questions about school satisfaction that match those used in the *Longitudinal Study of Australian Children* (LSAC, [www.growingupinaustralia.gov.au/](http://www.growingupinaustralia.gov.au/)) were used in our study, together with eight other questions devised by our research team. The additional questions sought to cover areas such as belonging ("I feel proud of belonging to my school") and feeling supported at school ("I feel supported by my school in the things that I do") that were not included in the LSAC group of questions. The combined items provided a measure of school satisfaction and allowed an investigation of the connection of school satisfaction with students' well-being.

## Contentment at School

Students' contentment at school was assessed using emoticon-like images. Students were asked to indicate which was most like them when they were at school by selecting one of the faces below (an adaptation of Andrews and Withey's (1976) face scale). As shown in Figure 49, nearly three quarters (71.8%) of IB MYP student participants reported being happy, while less than ten percent (9.3%) reported being unhappy.

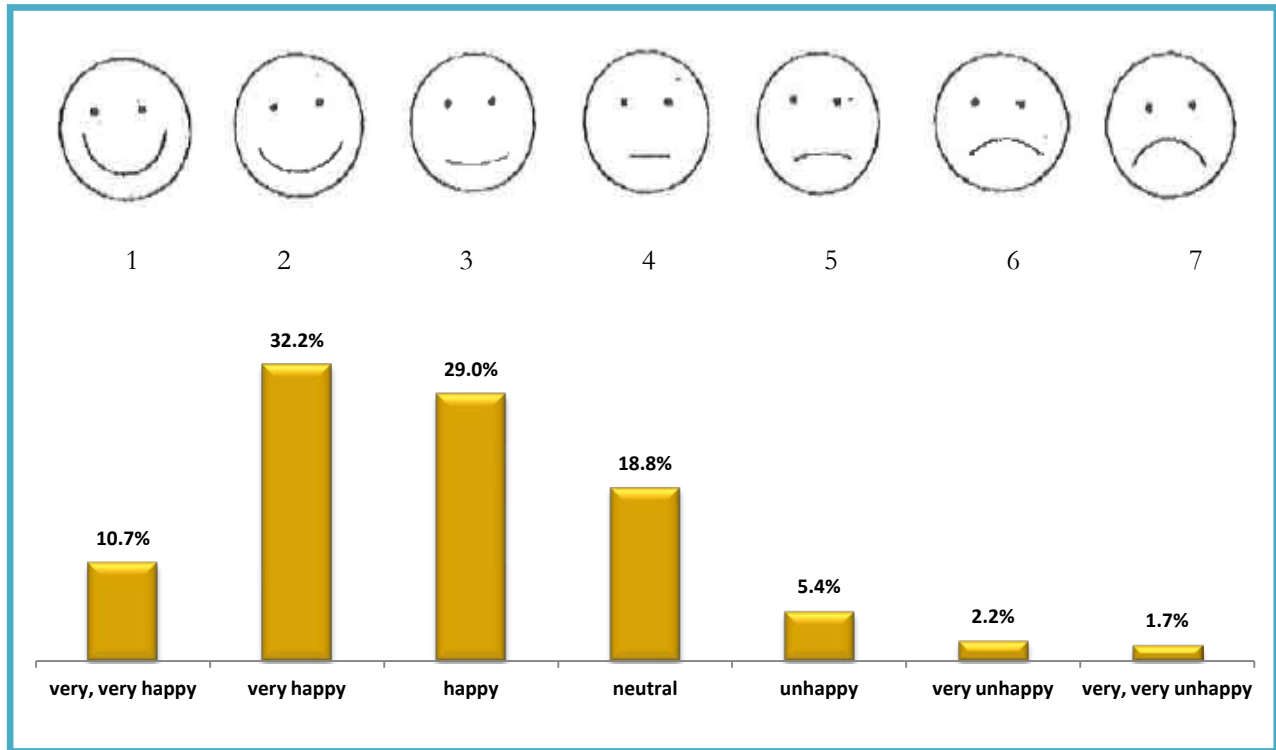

Figure 49 Self-reported happiness at school of IB MYP students

An analysis of this question, controlling for school, found that there was a significant difference between students from different socio-economic backgrounds in their self-reported level of contentment at school ( $F(2) = 6.3, p < .002, E.S.(r) = 0.09$ ). As shown in Figure 50, students from high SES backgrounds were more likely to have reported being happy at school compared to students from low SES who were more likely to have indicated that they were unhappy, although the effect size was small.

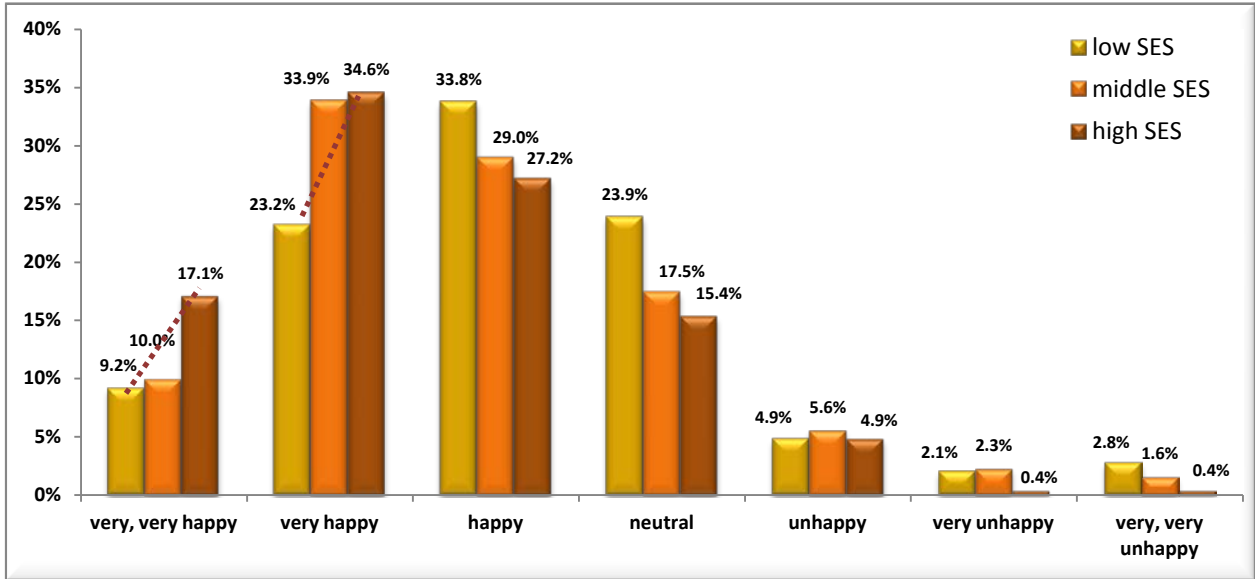

Figure 50 Self-reported level of happiness at school of IB MYP students from different SES backgrounds

As shown in Figure 51, about 10% of students from low and middle SES were unhappy compared to only 5.7% of students from high SES. Similarly, being happy at school was more likely to have been reported by students from high SES than low SES backgrounds (i.e. 78.9% vs 66.2% respectively).

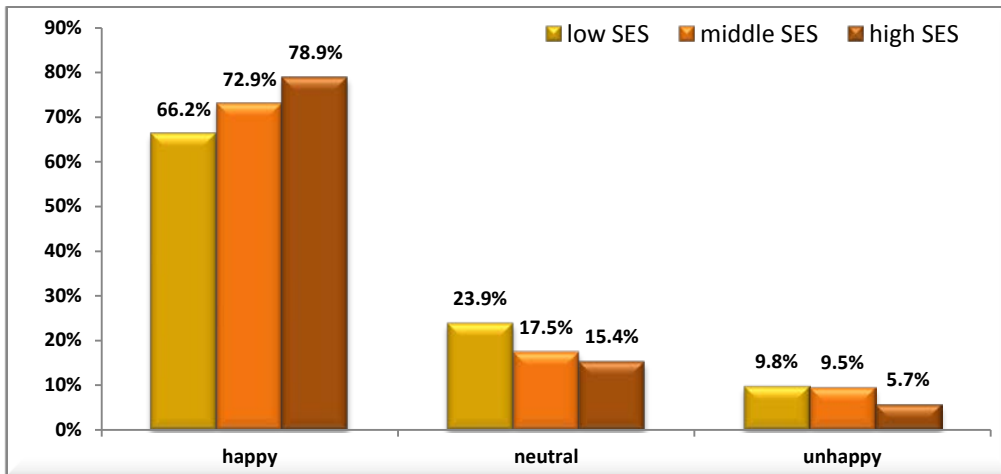

Figure 51 Self-reported level of happiness at school of students in low, middle and high SES



Another analysis which controlled for school and SES found that there was a difference in the level of contentment between students of different ages ( $F(5) = 6.2, p < .000$  – see Figure 52). Students aged 11-12 years were significantly more content than those aged 15-16 years. A similar trend was found across year levels ( $F(4) = 10.0, p < .000$ ) – see Figure 53). Students in the lower years of MYP (Years 6 & 7) reported more contentment at school than those in the upper years of MYP (Years 9 & 10).

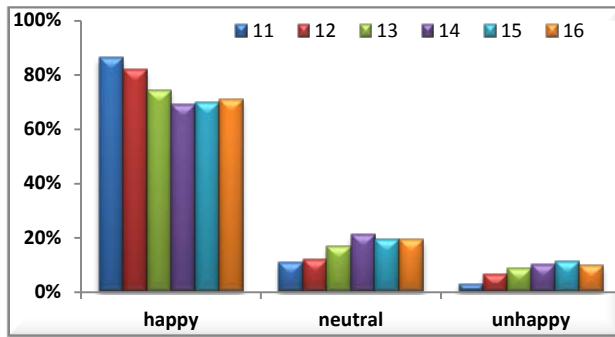

Figure 52 Happiness at school by age

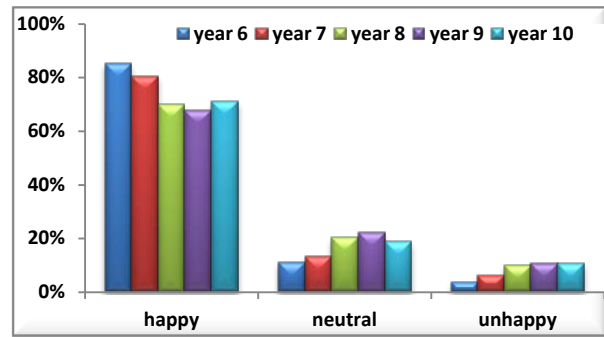

Figure 53 Happiness at school by year level

## Comparison with Other Schools in South Australia

A comparison of IB MYP students with 1,376 students aged 11-15 (mean = 13.4 years, S.D. = 0.94), who answered this question while they were attending a school in the southern region of Adelaide in 2007, found that IB MYP were generally not as happy (see Figure 54). However, our IB MYP student sample comprised of older students compared to students in the southern schools sample – half of the IB MYP sample (51.7%) were aged 14-15, while just over half (56.2%) of the southern schools' students were aged 12-13. Hence, we would expect lower levels of contentment amongst older students.

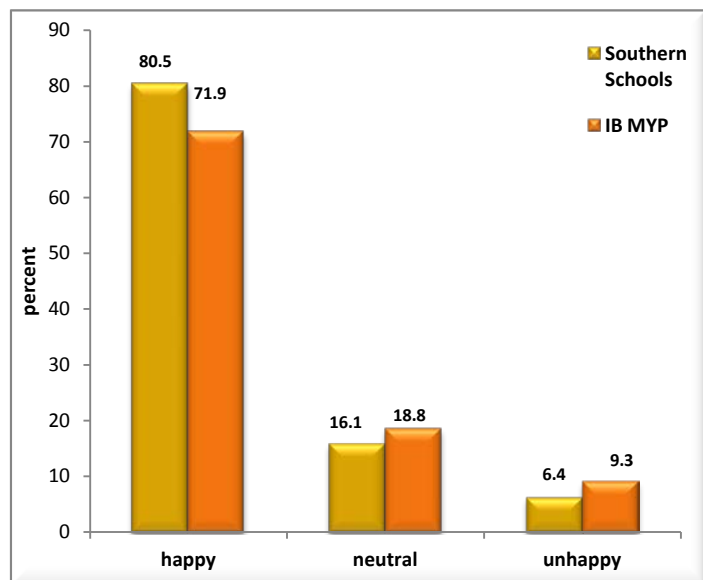

Figure 54 Happiness at school of IB MYP students and other SA students aged 11-16

## School Satisfaction

Items about school satisfaction were analysed using an exploratory factor analysis (EFA). A four factor solution was found to best fit our data ( $\chi^2(116) = 496.2, p < .000$ ; RMSEA: 0.042; 90% C.I.: 0.038 – 0.046; Probability RMSEA < .05: 1.000; CFI: 0.979; TLI: 0.965; SRMR: 0.016). A second order Confirmatory Factor Analysis (see Appendix B Figure 13) verified the structure of a higher order construct called “school satisfaction”, comprising of the four factors, “enjoy school”, “enjoy learning”, “feel supported” and “school fellowship”, with items as shown in Table 9. The factor score coefficients were used to generate scores for each student on each of the four factors. A significant correlation ( $r = .54, p < .000$ ) was found between the factors “enjoying school” and “enjoying learning”. This indicates that students who find learning enjoyable are also likely to find school enjoyable. The “feeling supported” factor was found to strongly load on school satisfaction (standardised factor coefficient = .934). This suggests that students who do not feel that their school supports them for example, by making them feel that they will be a success and supporting them in the things they do, or who are not proud of their school, are less likely to find school satisfying.

**Table 9** Factors and indicators of the School Satisfaction latent variable

School Satisfaction Factors	Item
Enjoy School	My school is a place where I feel happy
	My school is a place where I really like to go to each day.
	My school is a place where I get enjoyment from being there.
Enjoy Learning	My school is a place where I find that learning is a lot of fun.
	My school is a place where I like learning.
	My school is a place where the work we do is interesting.
	My school is a place where I like to ask questions in class.
	My school is a place where I always try to do my best.
	My school is a place where I get excited about the work we do.
Feel Supported	My school does whatever it can to help students.
	My teachers always find time to talk to students
	If I have a problem there is an adult at my school that will help me.
	I feel supported by my school in the things I do.
	My school makes me feel that I will be a success.
	I feel proud of belonging to my school.
School Fellowship	I get along with other students.
	At school I participate with anyone or any group.
	I have a sense of togetherness with the other students in my class.

An overall school satisfaction latent variable was calculated and it was standardised to assist with interpretation. The findings shown in Figure 55, indicated that over three quarters (80.5%) of IB MYP students were quite satisfied with school and very few ( $n=5$ , 0.3%) reported that they were very dissatisfied with their school.

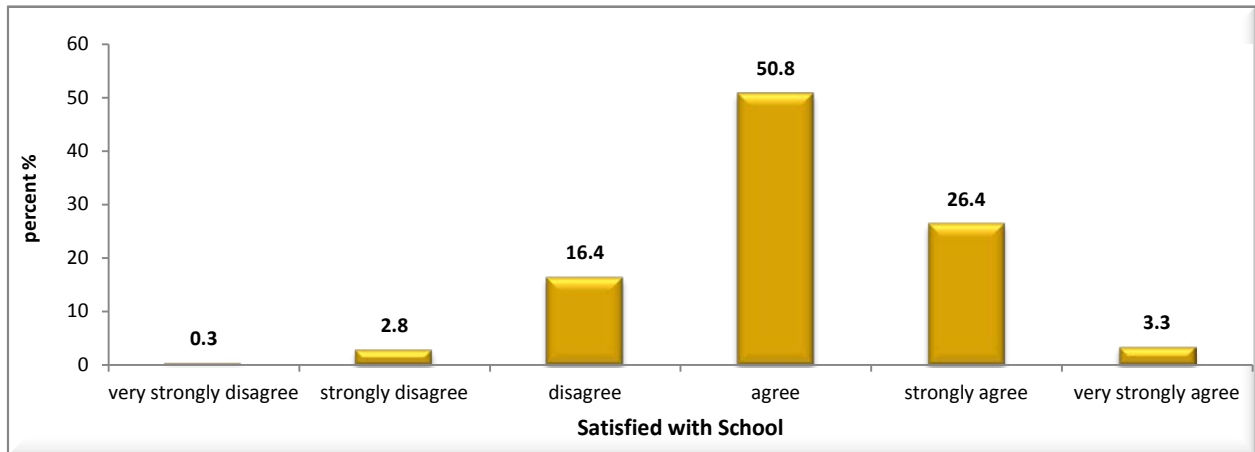

Figure 55 Level of satisfaction with school of IB MYP students

Males (82.3%) were more likely than females (78.7%) to report feeling satisfied with school ( $t(1777) = 2.3$ ,  $p < .05$ ,  $E.S.(r) = 0.05$ ), but this difference was very small (see Figure 56).

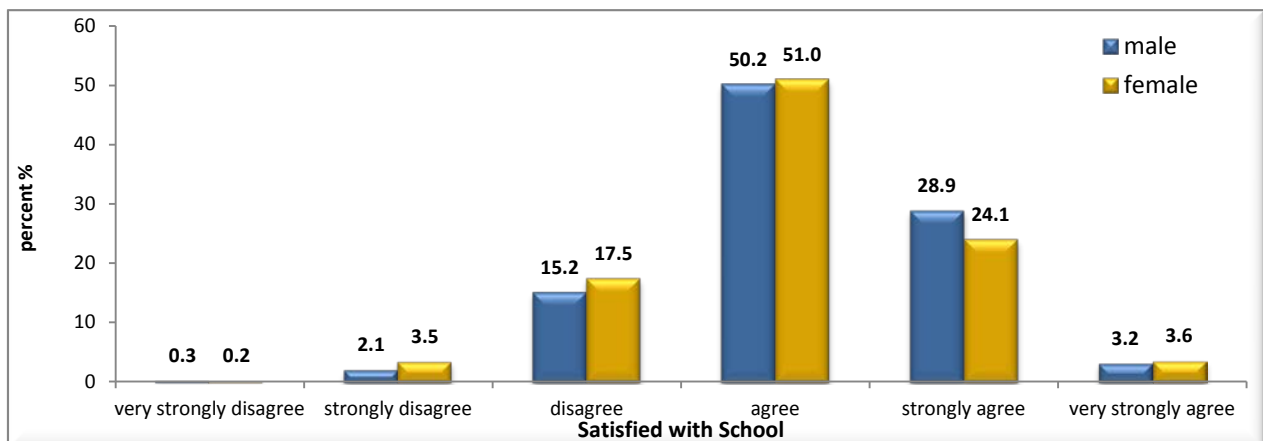

Figure 56 Level of satisfaction with school of male and female IB MYP students

## Components of School Satisfaction

To further investigate school satisfaction, the components that comprised the overall school satisfaction construct were examined separately. As the results below show, over two thirds of IB MYP students reported that they enjoyed learning and going to school, as well as felt supported and part of the school community.

### Enjoy School

An analysis of the “enjoy school” latent variable, found that 72.0% of IB MYP students reported that they enjoyed school (Figure 57).

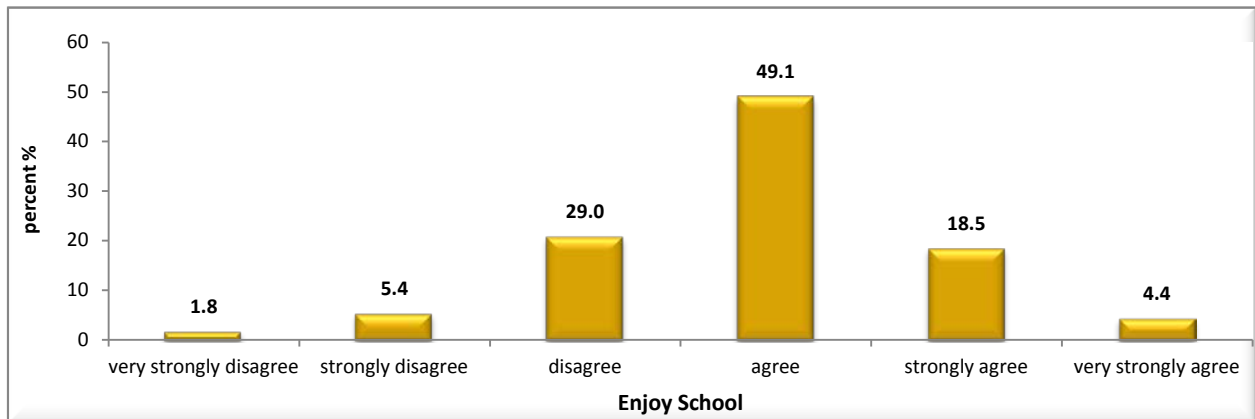

Figure 57 Extent of enjoying school of IB MYP students

There was no significant difference in the proportion of males' and females' enjoyment of school. As Figure 58 shows, over 70 percent of males (74.2%) and females (70.2%) reported that they enjoyed going to school.

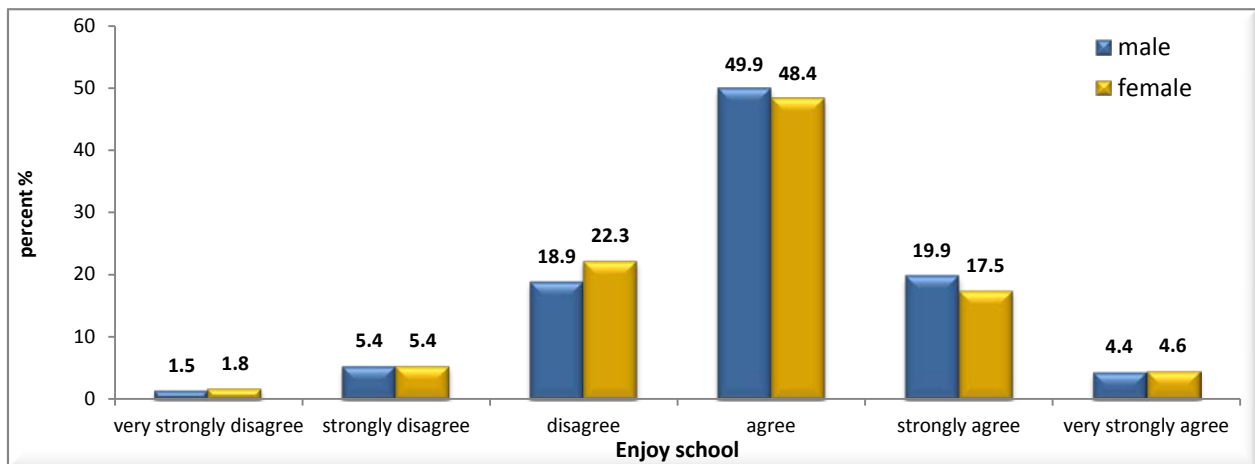

Figure 58 Extent of enjoying school of male and female IB MYP students

## Enjoy Learning

An analysis of the “enjoy learning” latent variable found that 69.7% of IB MYP students reported that they enjoyed learning (see Figure 59).

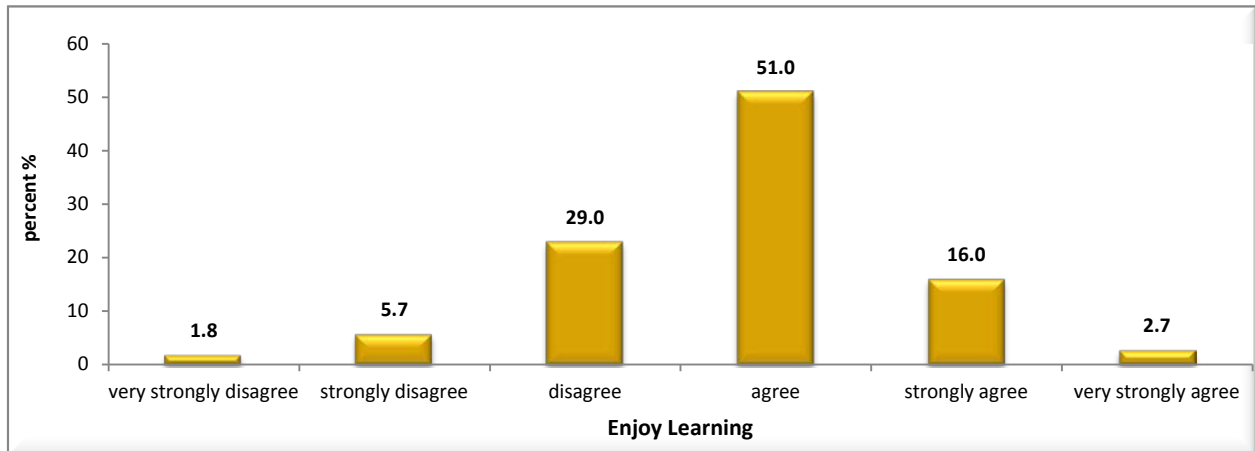

Figure 59 Extent of learning enjoyment of IB MYP students

There was no significant difference in the proportion of males' and females' enjoyment of learning at school. As Figure 60 shows, about 70 percent of males (70.2%) and females (69.9%) reported that they enjoyed learning at school.

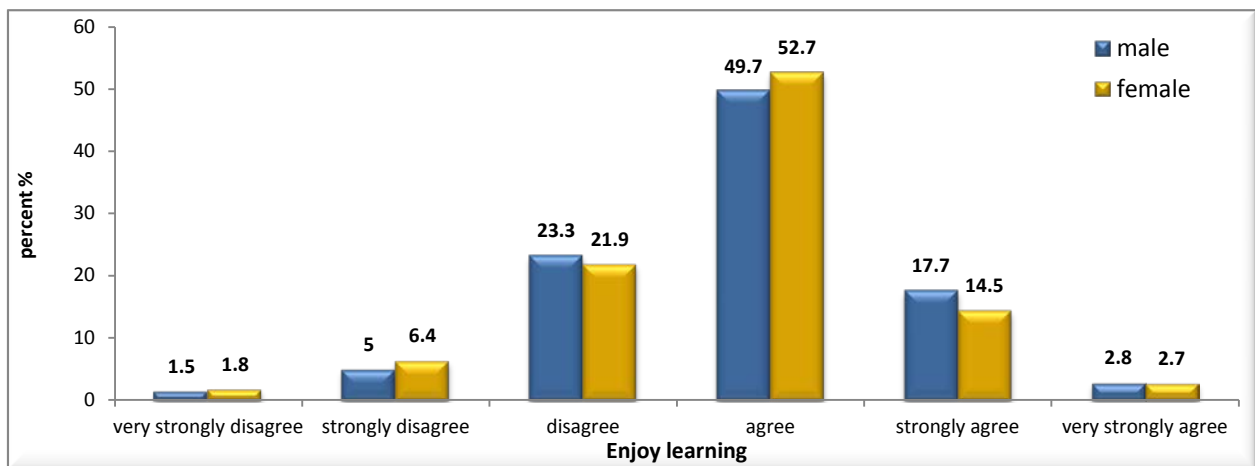

Figure 60 Extent of learning enjoyment of male and female IB MYP students

## Feel Supported

A large proportion (70.8%) of IB MYP students felt supported by their school, according to an analysis of the “feel supported” latent variable (see Figure 61).

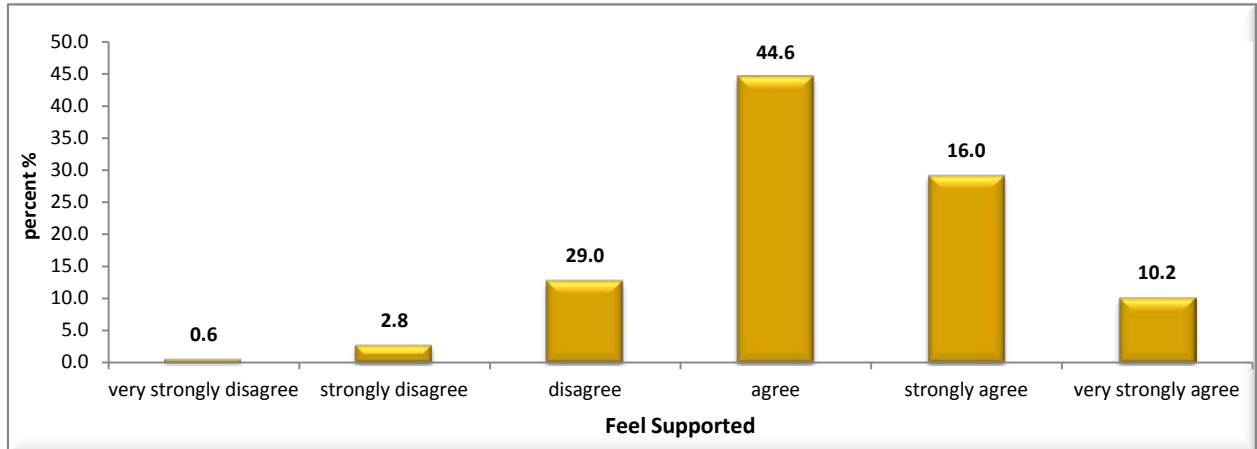

Figure 61 Extent of feeling supported at school of IB MYP students

However, males (85.4%) were more likely than females (82.1%) to feel supported at school ( $t(1834) = 2.5, p < .05, E.S.(r) = 0.06$ ), although this difference was very small (see Figure 62).

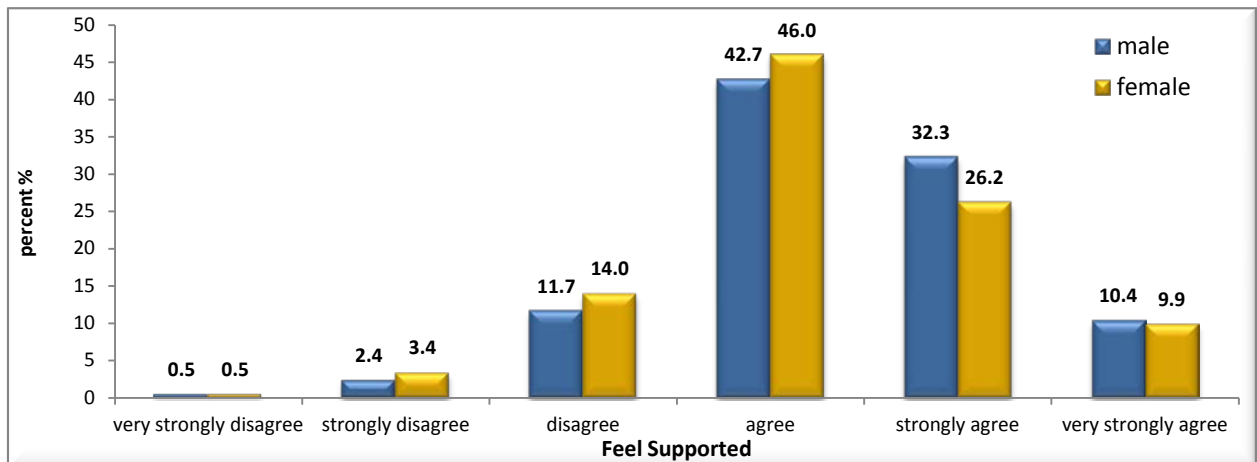

Figure 62 Extent of feeling supported at school of male and female IB MYP students

## School Fellowship

The latent variable scores of school fellowship found that four in five (80.1%) IB MYP students reported an experience of fellowship at school (see Figure 63).

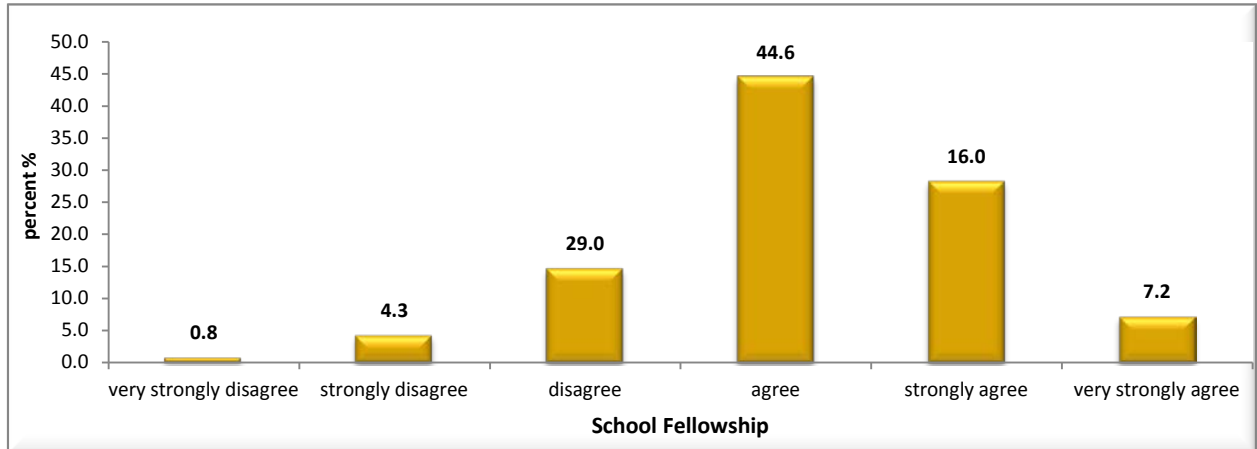

Figure 63 Extent of school fellowship of IB MYP students

There was no statistical difference between males (82.0%) and females (78.6%) in their school fellowship scores, as shown in Figure 64.

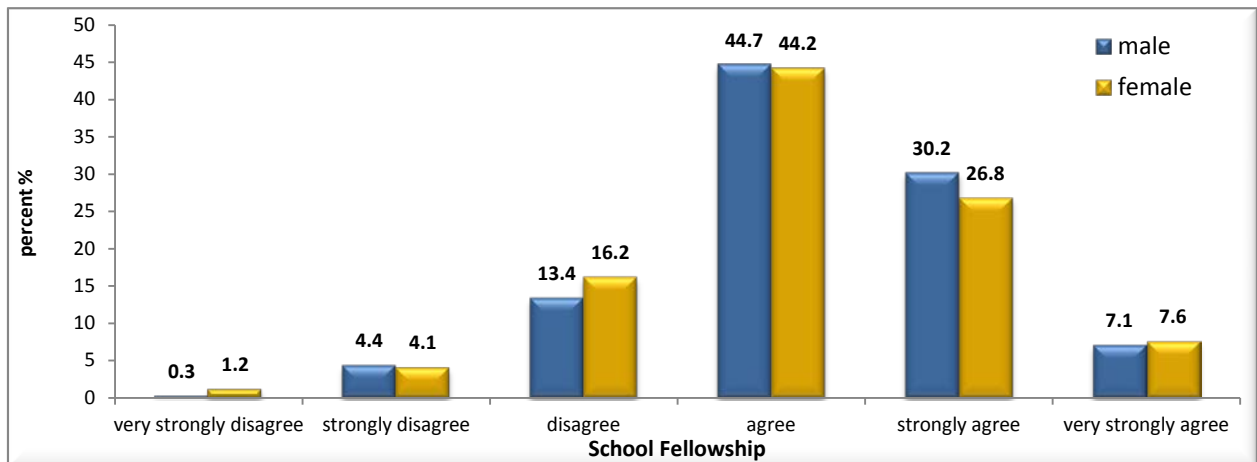
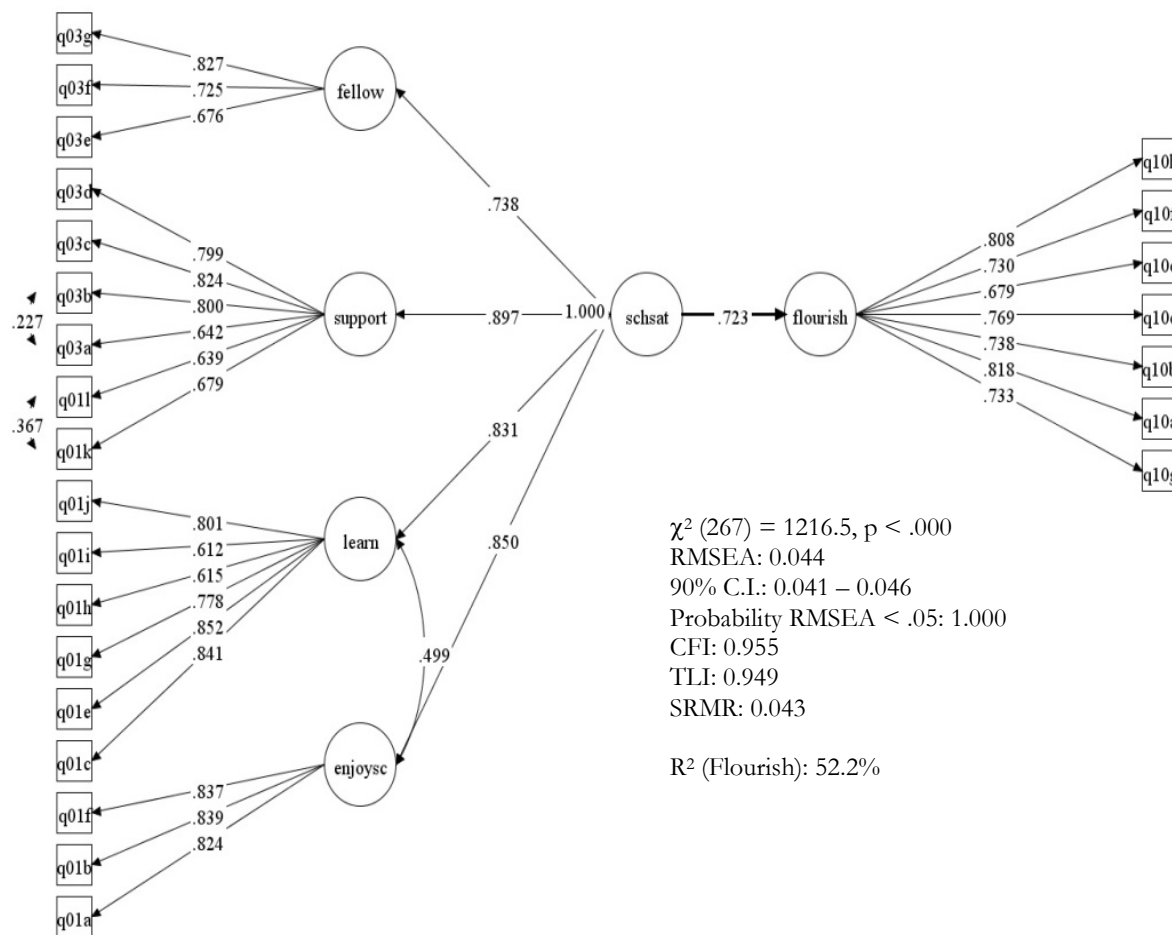

Figure 64 Extent of school fellowship of male and female IB MYP students

## School Satisfaction and Well-being

Structural Equation Modelling was used to examine the relationship of our three well-being measures i.e. FloS, MentHC and StirCWB, with the components of school satisfaction. As shown in Figure 65 (a) – (c) School satisfaction was a good predictor of well-being and was associated with just over half of the variance of flourishing (52.2%), Positive Emotional State (51.4%) and Positive Outlook (53.5%) and about 40 percent of the variance associated with Emotional Well-being (39.8%), Psychological Well-being (40.3%) and Social Well-being (42.9%).

(a) School Satisfaction and FloS





(b) School Satisfaction and MentHC

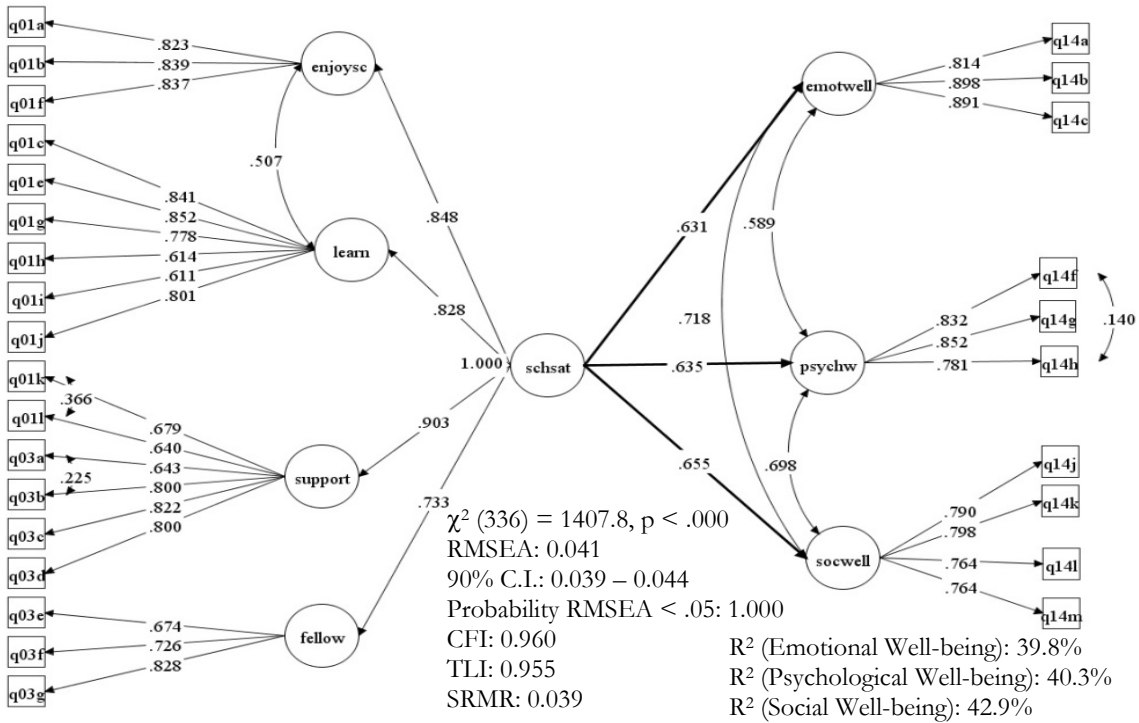

(c) School Satisfaction and StirCWB

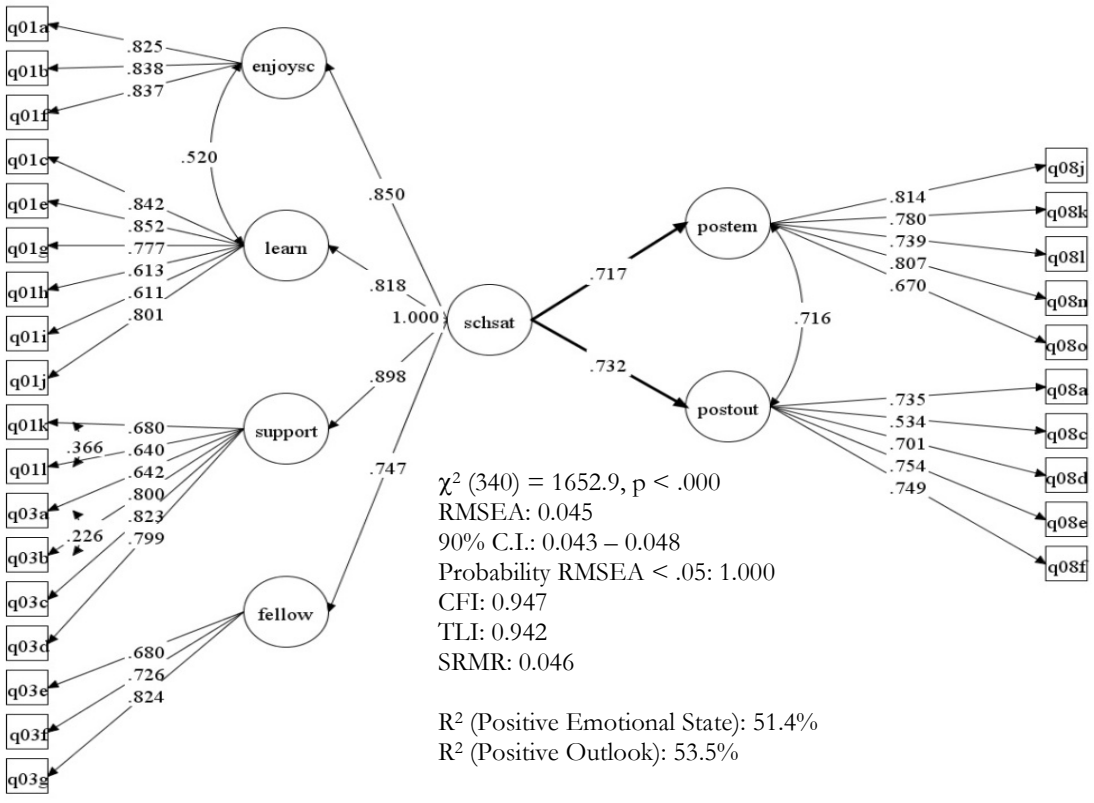

Figure 65 School satisfaction as a predictor of well-being

## Bullying

Students who participated in the quantitative study also completed questions about bullying, including items from the Peer Relations Questionnaire (Rigby & Slee, 1991) and a single question about the frequency of bullying. As shown in Table 13, just under half (49.1%) reported that they had never been bullied, while a further 31.6% reported that they had been bullied less than once a week. Students in this category are considered to have not been seriously bullied. According to Boulton and Underwood (1992), students who are bullied about once a week or more often are considered to have been “seriously bullied”. Following this delineation, nearly one in five (19.2%) IB MYP students reported being seriously bullied at school (Table 10). Research by Slee (2005) found that 22.7% of South Australian students in this age group were bullied about once a week or more, slightly more than in the current study.

It was difficult to make other comparisons of the prevalence of bullying with other studies. This is because different studies use different measures of bullying. In the Australian Covert Bullying Prevalence Study (ACBPS) undertaken by Cross et al. (2009) of 20,832 Australian students, for example, bullying was gauged by how many students were *frequently* bullied i.e. bullied every few weeks or more often in a school term. Using this criterion they found that just over one quarter (27%) of Australian school students aged 8 to 14 years were experiencing bullying. The ACBPS also found that *frequent* bullying was more common for Year 5 students (32%) and Year 8 (29%) students. While it is not appropriate to make comparisons of the prevalence of bullying in our study the incidence of *serious* bullying of the Year8s in our study was 20.2%. A comparison with the ACBPS is however, unwise as it is not clear whether the definition of frequent bullying and serious bullying are equivalent.

**Table 10** Bullying status of IB MYP students

How often this year have you been bullied or harassed by a student or students at school?											
never		less than once a week		about once a week		one or two days a week		most days		every day	
Count	%	Count	%	Count	%	Count	%	Count	%	Count	%
936	49.1%	602	31.6%	133	7.0%	119	6.2%	88	4.6%	27	1.4%
Not bullied		Not seriously bullied		Seriously bullied → 19.2%							

## Bullying by Gender and Year Level

Analysis of the self-reported level of bullying by IB MYP students found that there was no statistical difference in experiences of being bullied between males and females. As shown in Figure 66, nearly half of

the male (49.3%) and female (48.4%) students reported that they were “never” bullied, while 6% of males and 5.8% of females experienced being bullied most days or more often.

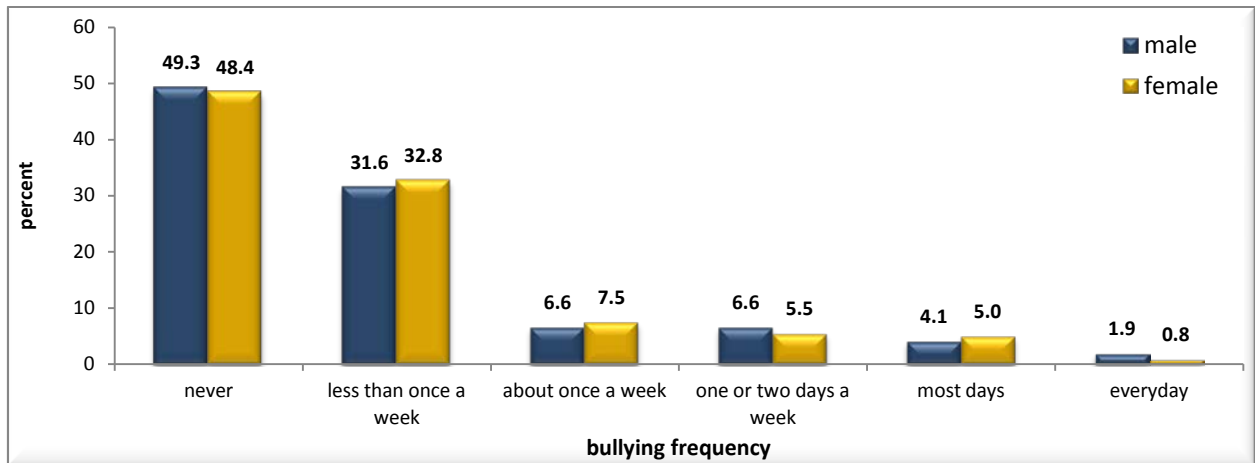

Figure 66 Self-reported levels of bullying of male and female IB MYP students

There was no significant difference in the level of serious bullying reported by males and females, as shown in Figure 67.

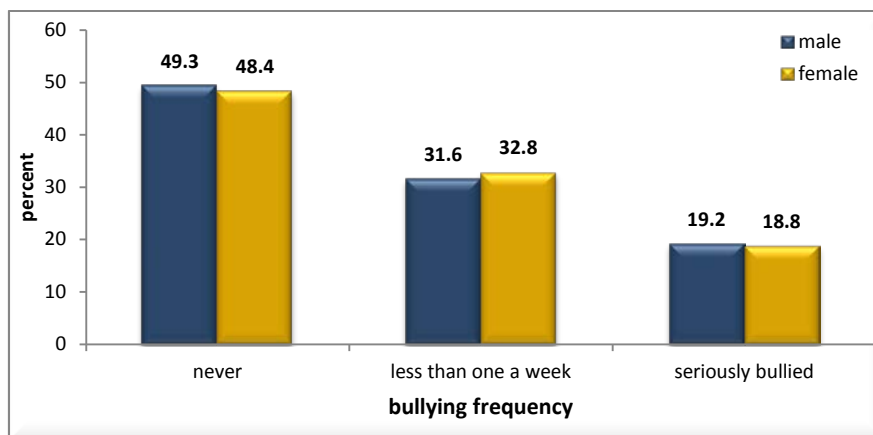

Figure 67 Self-reported levels of serious bullying of male and female IB MYP students

The level of being bullied for different year levels was found to be less in Year 7 compared to Year 6 and in Year 10 compared to Year 8. The decreased level of bullying across the middle years is illustrated in Figure 68, which shows that the incidence of serious bullying decreased from Year 6 to Year 10.

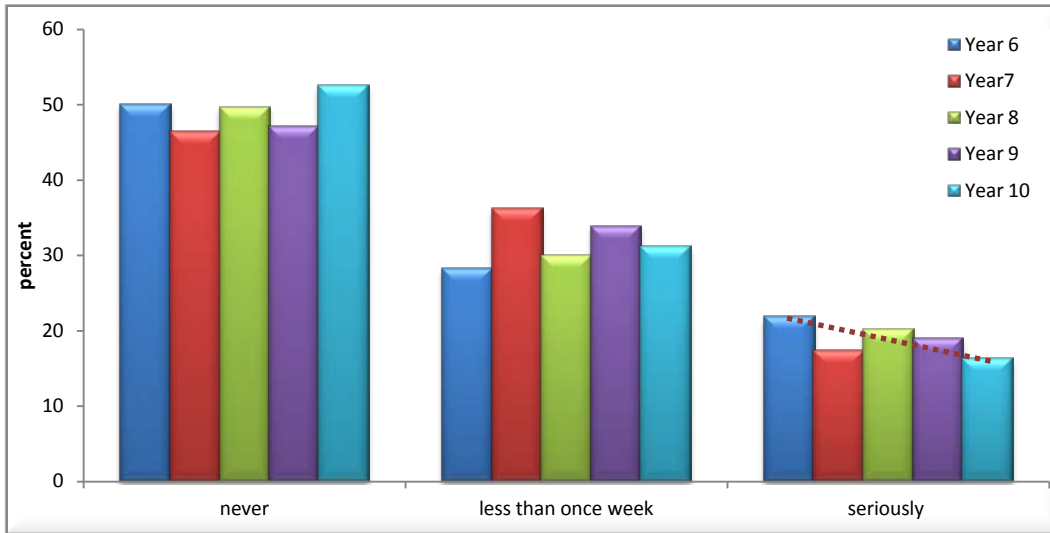

Figure 68 Incidence of self-reported bullying of IB MYP students by year level

## Empathy and Bullying

As the literature has suggested (Sutton, Smith & Swettenham, 1999; Andreou, 2004) cognitive empathy was found to significantly predict bullying others, while the presence of affective empathy was associated with a decrease in the likelihood of bullying others. As shown in Figure 69 (a) – (c), the regression coefficient of bullying others on cognitive empathy was 0.225 ( $p < .000$ ), while on affective empathy it was -0.517 ( $p < .000$ ). This suggests that high levels of affective empathy are associated with low levels of bullying others.

The analysis also suggested that the presence of affective empathy was associated with a decrease in the likelihood of being bullied (Regression Coefficient = -.138 ( $p < .000$ ), while the presence of cognitive empathy had the opposite effect (Regression Coefficient = .212,  $p < .000$ ). One interpretation of this finding could be that victims with cognitive empathy might also bully others (i.e. are bully-victims). Some support for this interpretation is the significant correlation between bullying others and being a victim ( $r = 0.316$ ,  $p < .000$ ) which indicates that the more one bullies, the more likely one is to be bullied.

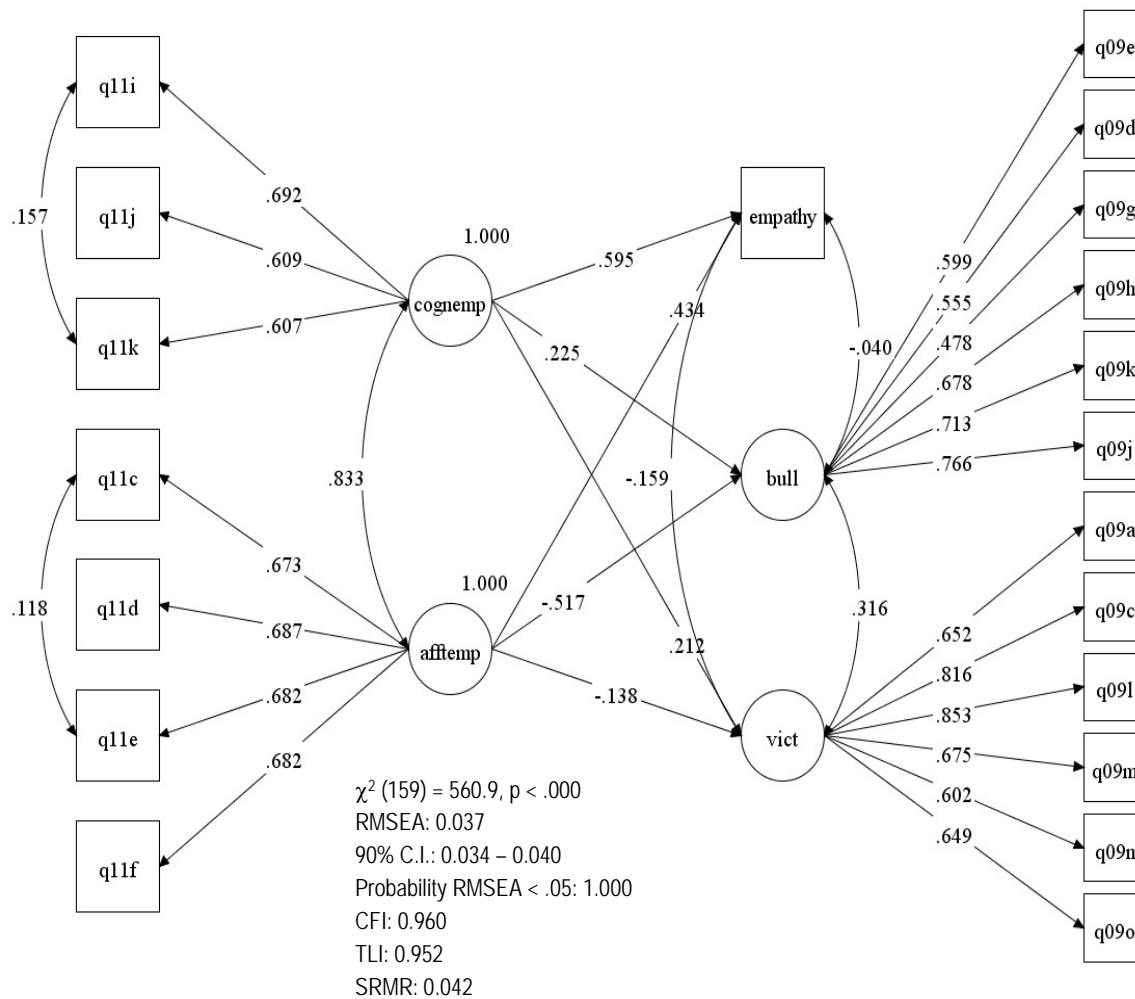

Figure 69 Cognitive and affective empathy as predictors of bullying others and being bullied

## Students' Comments and Drawings about Satisfaction with School

The comments provided by students in the WBQ open-ended question indicated that the majority of IB MYP students were quite satisfied with school since 82.2% of the responses were positive. Examples of typical responses which implied that a student was happy at school are shown in Figure 70. As the drawings show, across year levels, male and female students provided illustrations that expressed that school made them happy.

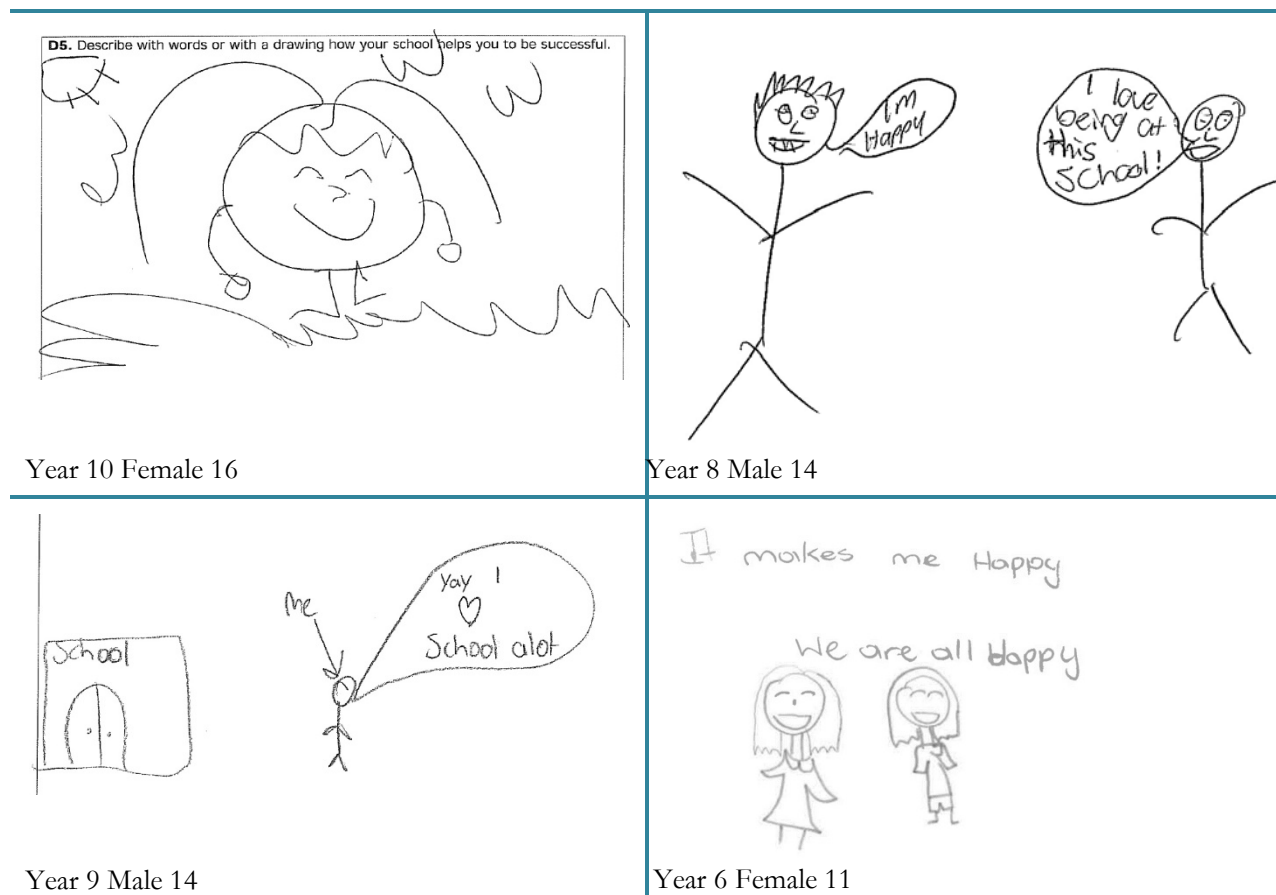

Figure 70 Illustrative examples of being happy at school provided by IB MYP students

## Discussion

Most IB MYP students appear to be quite content and satisfied with school, although males were more likely than females to report that they felt supported at school. However, further research would be required to investigate the likely nature of this difference.

School satisfaction was found to be a strong predictor of flourishing, a positive emotional state and a positive outlook. It was significant, but accounted for less variance in emotional well-being, psychological well-being and social well-being. These results suggest, as staff and students had noted in the qualitative study that being happy at school was significantly associated with student well-being. The strategies and practices being undertaken by schools to address students' needs currently contribute to this satisfaction. However, more could be done to assist some females, particularly in the upper years of MYP achieve greater satisfaction from school.

Our findings suggest that the incidence of bullying in IB MYP schools was slightly less than found in other studies of South Australian students (see Slee, 2005).

As the literature has suggested cognitive rather than affective empathy was found to be related to bullying others. Our study also found that affective empathy was more likely to be associated with being bullied less and a lower likelihood of bullying others. Affective empathy was an attribute in over half of IB MYP students and therefore low rates of bullying would be consistent with this.

# School Success Practices

---

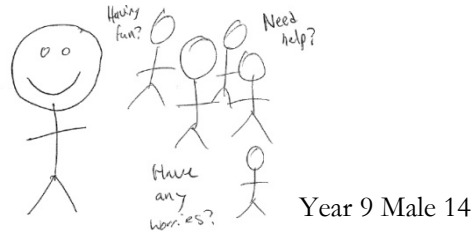

In addition to examining the social and emotional well-being of IB MYP students, our study also sought an investigation of school success practices that contribute to student well-being and promote student success.

The social and emotional worlds of middle-school children become increasingly complex as young people transition through puberty and manage the challenges of increased responsibility and autonomy (Newman & Newman, 2012). One unfortunate outcome of the changes concerns the impact of stress on the individual (Slee & Shute, 2014) and there is increased risk of maladjustment. It is during the adolescent years that teenagers are most susceptible to eating disorders, depression and delinquency (Newman & Newman, 2012). The IB MYP is designed to assist and guide students in the middle years, as they develop a sense of identity and search for a sense of place in their natural and social environments. This may be facilitated in schools by supporting the social, emotional and physical well-being of students (IBO, 2013).

An assessment of how well schools support student success and socio-emotional development in this study was determined qualitatively through interviews and focus groups with staff and students. During the interviews, IB MYP staff were asked to provide details of programmes, actions and policies undertaken to enhance student well-being and facilitate student success. Staff responses to queries about student well-being programmes have already been discussed in chapter 4. In this chapter we discuss staff's views of success and practices they employ to ensure success.

The focus groups provided students with an opportunity to voice their opinions and provide their perspective of their social and emotional well-being and the support they felt was available to them at school. These views have been reported in chapters 4 and 8. Responses provided by students to the open-ended question “describe with words or with a drawing how your school helps you to be successful” in the WBQ also informed this part of the investigation, and those findings are reported here.

We deliberately did not define “success” for our study participants, rather we asked them to tell us what they perceived as “success” and then to describe how this “success” was facilitated in their school. In this chapter



we present IB MYP staff and students' perceptions of success and discuss the enablers and barriers to success suggested by staff.

## The Concept of Success

### Students' Views of Success

Students provided their views and concepts of “success” during the focus groups. They acknowledged that success comprised many things in addition to academic achievement and grades. For many students the concept of success was directly related to achieving a goal, irrespective of what the goal was, as the following quotes suggest:

*... something simple like weight loss or something, maybe, and like getting an A in a certain subject maybe. (Female, Year 9)*

*Achieving your goal. (Male, Year 7)*

*Achieving a goal I guess. You set goals for yourself and then success is when you finally reach them. (Female, Year 8)*

*Reaching a goal; completing it. Being able to meet your own goals and aim further because you know you are able to do it. Getting consistent grades in your subjects, you know you're doing a good job. Being satisfied with how you work in school. (Female, Year 9)*

*Success when you achieve your goal that you wanted, that's probably success. (Female, Year 10)*

In the open-ended WBQ question, students provided similar insights:

*"Successful" is a very broad term to me...It is really dependent on the type of success one wishes to achieve... (Male, Year 10)*

*School is the key to knowledge, without which humanity would suffer. Knowledge will give my life meaning and hopefully it will bring forth change, a sense of direction. To me, this is the ultimate success. (Male, Year 10)*

*My school is the only way I will have success in life. It helps me learn to become a better person. (Male, Year 7)*

*My school is a place where I feel success is always thriving and flourishing. It is a place that teaches many things about life. It helps me to be successful because I am ensured within school to succeed. (Male, Year 8)*

*My school helps me be successful by showing me that success stems from hard work, friends and family. (Male, Year 9)*

*Education=university=a degree in medicine= success. (Female Year 10)*

## Staff's Views of Success

School staff provided a more sophisticated definition of success, connecting it to social and emotional well-being, which as the following quote suggests, was considered crucial for success:

*I think success is such a big thing. With a teacher's hat on you think academia. But you're not going to get that, and that is actually probably not even what you should be trying to get in certain situations. And it doesn't even need to be such a critical emotional issue. There are some students who just by personality or by upbringing find it very difficult to socialise, their social skills are really lacking. Well, I would say that getting that sorted would be the success that we want, over the academic. (MYP Coordinator)*

Staff noted that general well-being and happiness were essential elements for success:

*It's about kids being happy ... because if they're happy then the other components of school will fall into place. They're more likely to learn. (Head of Middle School)*

*I suppose the reality is if you're not feeling good about who you are and feeling good about your place in the world then you're not going to be successful ... unless you're happy with who you are and you're place in the world, then I'm not certain you're going to make a very good doctor anyway, or a very good lawyer or a very good whatever. So, I think it's the very essence. (Principal)*

*If my kids leave at the end of the day and they've learned something and they've had a good day ... they've had a day where they've been able to engage in the curriculum ... they've had a day where they had a pleasant lunch time and recess time with their friends and they're happy to come back tomorrow ... that's what I would think a Year8 classroom would be successful. (Head of Middle School)*

*I think just to see them confident I think is to be successful ... for them to be able to acknowledge what their strengths are and think of areas they need to improve on, to have that self-awareness I think is to be successful for them. (Well-being Coordinator)*

*I just figure that if our students are smiling when they're coming to school, are smiling during the day and smiling when they're walking out, then they'll do as well as they can. They've got to be happy at school, and then the other stuff will take care of itself. (MYP Coordinator)*

*If students don't have positive well-being then trying to get them to learn or anything else on top of that is just ... like the foundations are just going to crumple. (MYP Coordinator)*

For some staff assisting students with challenges so they could achieve goals was central for student success:

*Success I guess is in a way getting them to that end point whether it is end of the year, end of the term, end of the middle school ... being at this campus because each one you sort of have to have those little successes along the way. So I guess it's being able to support them to get over that hurdle whatever it is whether it's academic or whether it's personal. It's about getting them over that hurdle. (Counsellor)*

As the core business of educators, the notion of good grades and student achievement was undeniably linked to success, although staff generally acknowledged it was a minor component of success, as the following quotes suggest:

*There's academic success as well, which is just a small part of all that. (MYP Coordinator)*

*[it] depends on the student I suppose. For some it's achieving straight 7s for others it's getting one score above what they got in their last assignment. (Head of Middle School)*

*Success isn't just academic success. And I think too often when we talk about success, people quickly go to the grades that someone gets, or the results that someone gets ... But success is bigger than that, and I think what's got a lot to do with success is the child that might have missed 20 days last year, but has only missed five days this year. (MYP Coordinator)*

*I think it's relative for students, but in an IB sense it's if they're getting it, you know, a 4 or better in a subject ... they're achieving at a passing level. (MYP Coordinator)*

An interactive, student-centred classroom, where students were engaged in collaborative activity was how one staff member ardently described success. His depiction of the successful classroom environment portrays a potentially transformative setting:

*You see kids collaboratively working with talk that's busy talk ... that constructive talk and you can see that they're engaged and they're involved in an enquiry ... that they're excited about it ... you walk into a classroom and you see stuff on the walls that reflects the curriculum; you see the kids engaged and you know that what you're seeing is a successful environment in a class. You can hear it, you can see it. (Head of Middle School)*

The MYP was also credited by a school principal as a factor for student success:

*We've certainly noticed, and I think our senior staff would certainly say, that our young people when they go into Year 11 and 12, are much better at critical thinking, much better at analysing questions and much better at probably research type based essay writing than they were before we adopted the MYP. (Principal)*

In a similar vein, another staff member shared some anecdotal evidence that suggested the IB programmes (i.e. PYP, MYP and DP) at his school contributed to the success of students in Year 12.

*We did see our first lot who are PYP kids go through to Year12 a number of years ago now and there was a spike in the results. Now I don't know if it's anecdotal but there was quite a significant jump from the previous Year 12 year and that's kind of stayed - that's plateaued a bit. I think when you get kids that have come through the PYP they understand terminology they understand the process of enquiry. (Head of Middle School)*

## **School Success Practices According to Students**

In this section we report findings from the WBQ open-ended question which asked students to draw a picture or write about how their school helps them to be successful. Responses to this task were provided by 84.3% of participants. Of these, just over four in five (82.2%) provided positive comments about the school, while 6.2% were negative, and 11.0% were pictures or remarks which could not be classified as positive or negative, but were considered “mixed”.

## Positive Comments

The word cloud (shown in Figure 71), which was generated by NVivo, illustrates the words used by students in their responses. In the cloud, the size of a word is determined by the total number of times a word appears in the data. The word cloud produced from our data clearly illustrates the predominantly positive sentiments expressed by students about school. The most commonly used words included “school”, “helps”, “successful”, “learning”, “teachers”, “opportunities”, “encouraging”, “supportive”, “giving” and “friends”. Generally participants described their school as being one that helps students to become successful by offering opportunities for the future, with teachers who were encouraging, understanding and supportive and who “pushed” students to achieve their best. School was also perceived to be a place of learning where students would become “a better person”, where students were challenged and where they shared experiences with friends.

Examples of some of the positive sentiments provided by students are shown in Figure 72. The pictures are typical of comments made by students that suggested that school contributes to their happiness, and plans for the future, as well as providing encouragement and opportunities they would not otherwise have.

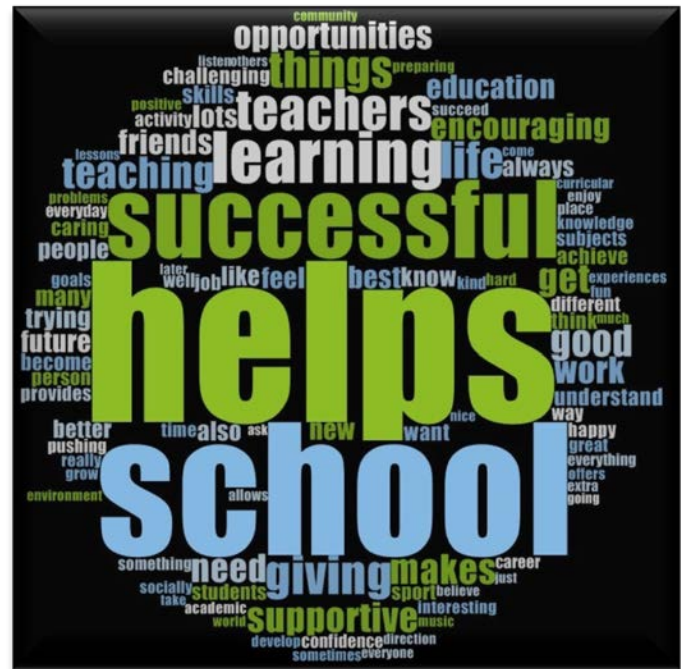

Figure 71 Word cloud of student responses about school

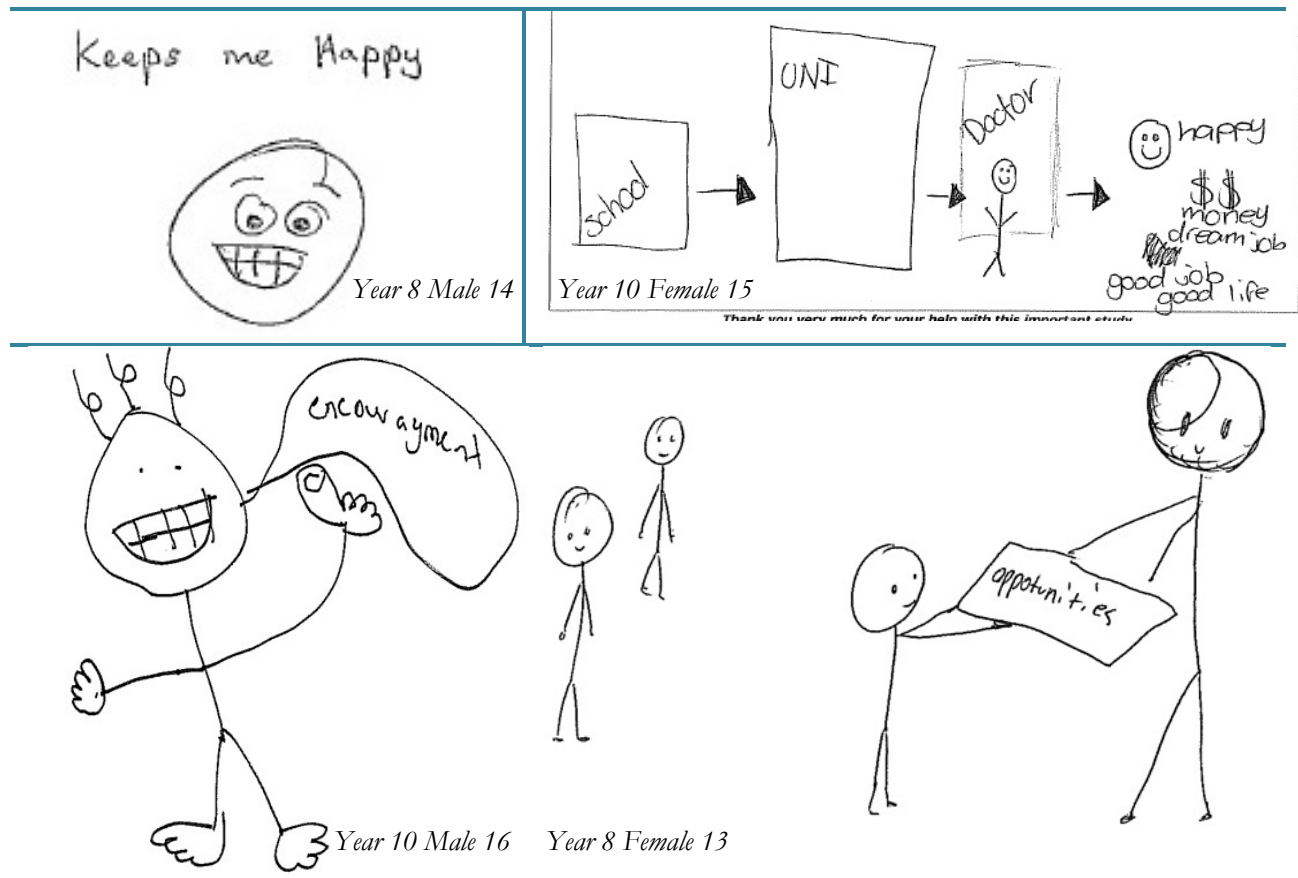

Figure 72 Examples of positive sentiments about school provided by IB MYP students

## Negative Comments

However, not all responses about school were positive. A small proportion of comments made by students about school were negative, and generally they expressed a sentiment that school “doesn’t” help students to become successful. Examples of negative comments are provided in Figure 73. Negative comments were equally distributed amongst schools, except for the three schools that chose the “opt in” consent approach (for participating in the study), where there were either no negative comments (in one school) or two at the most (in two schools). Drawings with a negative sentiment were not generally accompanied by words or explanations about why the student was not happy or satisfied with school. Where words were written it was typically “it doesn’t” and if there was a drawing it was of the sort shown in Figure 73.

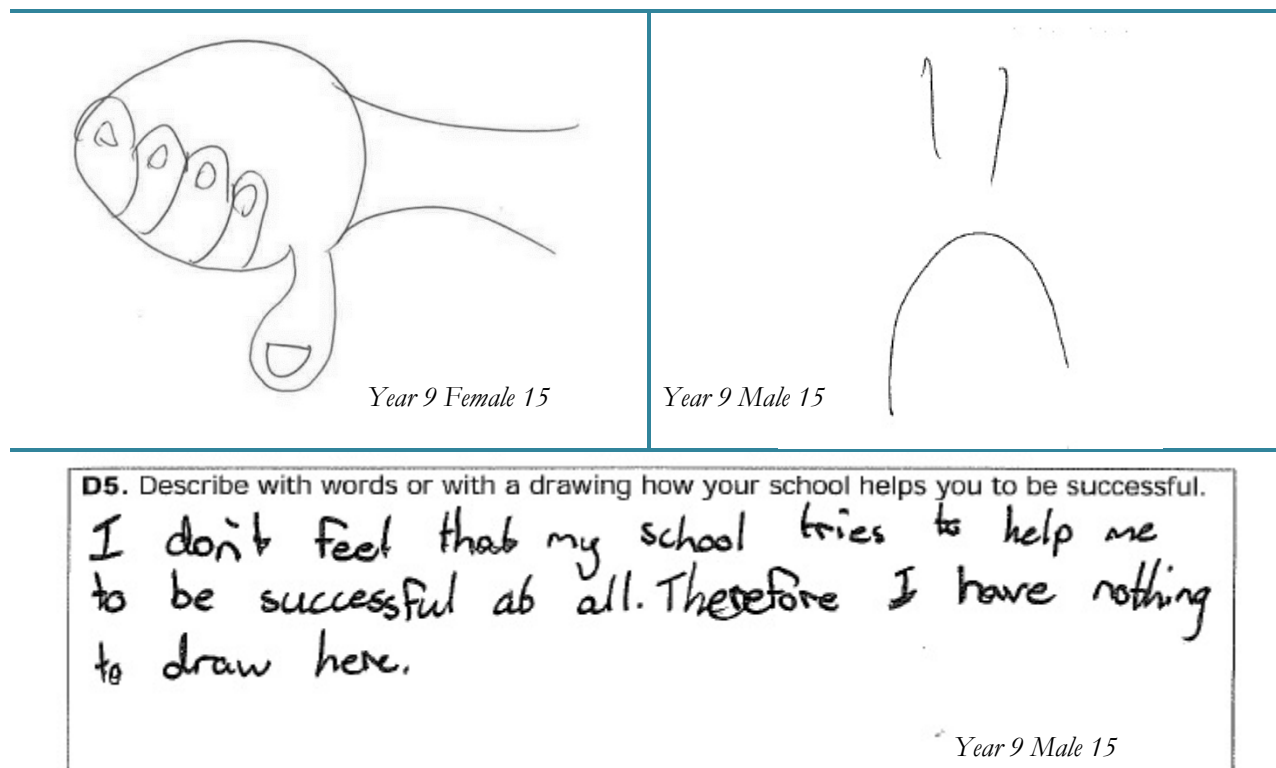

Figure 73 Examples of negative sentiments about school provided by IB MYP students

## Mixed Comments

As mentioned, some responses provided by students showed mixed feelings about school. The comments provided by two Year 8 females in Figure 74, are examples of the mixed feelings felt by some of the students whose comments were coded as “neutral” in our data analysis. While the comment of the 13 year-old student shown in Figure 74 acknowledges her caring school environment and the positive effect it is likely to have on her future, she is nonetheless critical and frustrated with the learning process that she perceives as demanding. Expressing a similar sentiment of mixed feelings, the other comment by a 14 year-old female highlights the stress felt by some students at school. Both comments suggest that school is a necessary burden that one must bear “to have a good life”.

<p>D5. Describe with words or with a drawing how your school helps you to be successful.</p> <p>I think that, yes, school is good for you and it is good to have challenges but not to a point where we break down crying, wanting to give up or even kill ourselves because of the stress. I've heard something about school making more people depressed and I can relate to that.</p> <p>Of course school is good though, but some teachers are not fair markers and there are all sorts of problems. Probably more than 50% of conversations is complaining about school. I'm not saying school is bad, it is good for us but try to understand our generation today, other people have it a lot harder than me and it scares me.</p> <p style="text-align: right;">Year 8 Female 14</p>	<p>D5. Describe with words or with a drawing how your school helps you to be successful.</p> <p>My school sometimes makes me feel like I'm about to explode. Everything is so slow and irrelevant.</p> <p>Our school is a good school, I am proud to go to my school. The teachers do care, but I think some teachers are not good at teaching. They leave the students to learn for themselves. I want to have a good life and this school will teach me all I need to know. But it often makes me angry.</p> <p style="text-align: right;">Female, 13</p>
--	---

Figure 74 Examples of mixed sentiments about school provided by IB MYP students

## Focus Group Findings

Focus group findings suggested that students were well aware that their school was making an effort to assist them to reach their goals and succeed. The following quotes are examples from students of how they could see their school was trying to help students succeed:

*They give you guidance on how to deal with problems throughout. Also they hire speakers to make sure you have people with knowledge to educate us on different issues ... in Year 10 when partying starts to become a bit of an issue you know they bring people to talk to you about that ... they talk to us separately if they think we're falling behind and they say can we help you in any way and they give us extra work, they give us extra time if we need it. (Year 8, Female)*

*They help you build friendships because you're with like with everyone all day most of the time (Female, Year 9)*

*They give us tasks and things like to do ... the tasks always relate back to the learner profiles. (Female, Year 8)*

*School definitely does make an effort for those who are struggling to develop their own natural ability to deal with problems and understand social situations they're in. It helps those who are struggling to catch up and makes sure everyone is at the same level. (Male, Year 9)*

*When we want to do something in class the teachers support us and give us that kind of knowledge to be able to reach that. (Female, Year 8)*

*They are very good about things, but sometimes if you're upset in class, if it's affecting you during class time your teachers will let you go outside and have time to yourself sort of ... but the counsellors are better because they actually will work on it with you and sort of let you do your own thing. (Female, Year 10)*



However, some students were concerned with teacher judgements about them and their behaviour (which would not have a positive impact on well-being). While this appeared to predominately be of concern to females, the unsolicited remarks were made from females from different year levels.

*It makes us feel like they look at us like, "Stupid kids getting into fights all the time," and girls being bitches and that ... just kind of makes us feel really tiny. (Female, Year 10)*

*... the teachers would judge you for what you do ... and they will go around telling the whole staff and then everybody knows. (Female, Year 9)*

*... the teacher is judging you on whether you're getting through on that, and you just don't really understand it. (Female, Year 7)*

While students could not provide specific details of the programmes and practices used by the school to promote student success they were aware that schools were “trying” and they could articulate some of the schools’ efforts. In the next section we provided details of how staff reported schools were helping IB MYP students succeed.

## School Success Practices According to Staff

Staff discussed enablers and barriers to assisting students achieve success. Enablers of success identified by staff included providing a safe and secure environment, attending to student well-being, ensuring good relationships with students and parents, empowering students, building student skills, possessing a culture of success, having a collaborative staff and supporting students with resources.

### Enablers of Success

Ensuring that students were in a safe and secure environment was considered paramount and vital for well-being and success. The following quotes stress the importance of safety at school, particularly, as the last quote highlights, for students for whom school provided a safe haven away from home.

*First and foremost it's about the students being, feeling safe and secure and happy within our environment. Ultimately if we want students to learn, they need to be safe and comfortable and happy in their environment - in that learning environment otherwise we're wasting our time. And then it's about them being able to help use that to help them achieve the best that they can. (Head of Middle School)*

*Sometimes in their world it is just crazy they have to be the first one home to get the couch for the night. Whereas here they know that they're going to have a seat and they know that they've got their own private area, which is their lockable locker, and you know they have their sense of identity when they come to school, that perhaps sometimes they're not experiencing in their living arrangements. I think that as long as we're consistent and persistent that they feel safe. (Well-being Coordinator)*



As the students in the focus groups acknowledged, schools exercised a great deal of effort in attending to student social and emotional needs, and took steps to enhance and maintain student well-being, as the following quotes demonstrate:

*We have a student services meeting which is held every 3 weeks and that's heads of school and counsellors and special needs coordinators and we get together and we talk about students of concern and then formulate action plans. So that's a minority of case management, but still we think it's really important to ensure some positive well-being across the school. (Well-being Coordinator)*

*We've got the Well-being Centre here with [psychologist]. So, on one side it's about helping our students who are struggling academically, but on the other side it's supporting students who are struggling emotionally. But it's not just students, often it's families who need the support along the way too, because they're struck with issues that they don't quite know how to deal with, and it's good to have these professionals on site, and they can give a bit of guidance to parents as well. (MYP Coordinator)*

Maintaining positive relationships with students and their parents were also discussed as very important for student success and well-being:

*I work a lot with the staff here about relationships, our own relationships, but importantly the relationships with the students and trying to build on those and make those as good as they possibly can be. (Head of Middle School)*

*We also have an open-door policy ... interviews for me are not week 10 Tuesday ... it's on-going throughout the term. We're consistently engaging. Parents know that they can drop in to our classrooms before or after school and we're going to be available to chat. (MYP Coordinator)*

*At the start of the year we write a letter, we give each parent, for every student that we teach, our email addresses and we just say that we're going to make regular contact home. So if we have any concerns or even praises, we'll phone home or send an email home. Quite often that might result in 20 emails over one week backwards and forwards. But it's really good to keep the parents in the loop because if they're in the loop of what's going on, the student is more engaged and switched on in the classroom. (Well-being Coordinator)*

In order to facilitate student success, it was considered important to empower students and facilitate student ownership of learning, something that is inherent in the MYP, as the following quotes affirm.

*We would see it as a pretty integrated programme with the MYP itself and the whole concept of student ownership within their learning empowers them and I think that's a really fundamental thing ... I think the MYP puts a great deal of emphasis upon empowering. (Principal)*

*They [students] get to make a decision collectively about where their education takes them and for them having a say is really empowering ... that's just one of many tools that we would use. We're always collaborating with the students. (MYP Coordinator)*

Building student skills was another theme presented by staff as enabling success. This included promoting student proficiencies academically, to assist learning, goal setting and organisational skills, as well as

identifying student strengths. The following quotes are examples of some of the skills schools sought to bolster student success.

#### Learning skills:

*The approaches to learning are an important part of that, so those skills around good communication skills; the ability to transfer information from one subject to another. Two of our reports each year are based around those approaches to learning, so not actually assessing the student, but we're just using the approaches to learning to give us a guide as to where students are at, basically at the end of term 1 and the end of term 3. So there is a focus around those approaches to learning which I think is important. (Head of Middle School)*

*One tactic that we're using at the moment in class is looking at what qualities make an effective learner. And so together as a class we've come up with a rubric to map out what a quality learner would look like ... we've just mapped that out over the course of the term and they've calculated their average scores and put that into a graph format and then done a spot analysis looking at their strengths, opportunities, weaknesses and threats around those results. (MYP Coordinator)*

#### Goal setting:

*We have in our middle school diaries at the beginning of each term we have a goal setting page. So one of the things that we do at the beginning of each term ... is to ask the students to sit down and "what is it that you want to achieve this term?" At the end of each term we do some reflection on those goals and "how did you go?"... And those goals could be around personal achievements, it could be academic achievements, it might be achievements in other co-curricular activities in other areas as well. (Head of Middle School)*

#### Identifying strengths and weaknesses:

*In terms of Year 10 students ... the work that students and the teachers do there around the personal learning plan and "what are my strengths and weaknesses?" and recognising "what it is that I might be wanting to do when I'm older, when I leave school. How can I channel those things together so that I am able to achieve success?" (Head of Middle School)*

#### Organisational Skills:

*Something that's come up through our junior school, which is basically some organisation techniques. So we've started to incorporate some of the stuff they're doing in the junior school. So it can be as simple as colour coding, all of our subjects have a colour code ... so when they go into science they know they grab the green book and anything with a green cover on it is a science subject, and just go and take that and that's an organisational skill. (Head of Middle School)*

*So within the learning areas we trialled something ... where students would basically reflect on their effort, organisation and achievements ... and asked "do you feel as though your organisation was tied to your success?" ... that kind of thing to really push that back on the learner. (MYP Coordinator)*

The culture of a school was considered by staff to be an important component of student success. Promoting a culture of success, and success in all its forms, was believed to be an enabler of success. Staff pointed out

that it was often the case that in some schools academic achievement was “frowned upon” (*Head of Middle School*) and this interferes with student success. As one participant explained:

*I think that there is still a bit of a sense that if you achieve academically you're a nerd, and no one wants to be a nerd. So therefore I'll hide my light under a bush and I'll just be average. And I think that's a really powerful peer thing ... That's not the case here, it's cool to be clever and I think that's a really important part of this culture to promote success. (Principal)*

According to staff, students benefit from being in a school where there is a culture of success as peer pressure enhances success and motivates languorous students.

*I think there's a culture of success too, and I think that breeds success. Having a son that's been through this school, I know that the boys around him dragged him up rather than dragged him down ... I used to work in schools where the students were dragged down. (Head of Middle School)*

*We're trying a different culture here in that we celebrate boys that do well, in the same way we do in sport, we celebrate boys that do well in class, and also with their effort, not just their academic achievement, we celebrate effort as well. (Head of Middle School)*

It was also important to ensure that students believed that *all* students had the potential to succeed, and this could be achieved by ensuring a differentiated curriculum, as the following quotes indicate.

*Another promoter of success is the fact that it's success for all. All kids are recognised for what they do. Not all kids are recognised for everything but when you are good at something or you are, you have reached a new level in what you have been able to achieve, you are recognised and I think that's really important. (Principal)*

*If the curriculum is excluding the student then they're not engaging and they're not happy ... they don't feel included in the curriculum. And that's really important that the curriculum allows success for all students and differentiates for all of the students as well. (MYP Coordinator)*

*But it's about ... how do we recognise that every student has gifts and talents, even if they can't always show them in our particular subject, they might be able to show them really well in other areas of their lives. (Head of Middle School)*

Student success was also inextricably linked to MYP staff and their enthusiasm, their ability to work together, support one another and communicate openly about important issues. Staff in the interviews provided the following insights about effective MYP staff:

*It's about the ability to have a balance of staff who are experienced and committed and understand, and new people who are excited about learning. They haven't quite solved, haven't worked it out yet, but they're excited and want to learn themselves and pick up the enthusiasm and see the potential of how the MYP can really work. And I think that's balanced team. (Principal)*

*We have good communication amongst our staff and you know have meeting structures where sub-schools can get together and talk about different tactics that they use in the classroom or how specific students are travelling, and obviously we've got our head of middle school and our counsellor and so they're always coordinating and communicating with the staff that are teaching those students. So everyone has an understanding of where different students are at, and what things work. (MYP Coordinator)*

*That pedagogy of collaborative work with not just the students but collaborative with the teachers as well, facilitates that relationship. What we have is a charism which is all about mutual respect and integrity and responsibility and a curriculum that supports that charism and when you got those two things it's a lot easier to create a culture in that way when you've got both an ethos and a curriculum that are heading in the same direction. (MYP Coordinator)*

*... a great team. Supporting each other, classroom teacher, counsellor, head of school, office administration all on board, all supporting, all talking. It couldn't happen without that. (MYP Coordinator)*

*When they come to school they come in with all of their problems from their family and their large responsibility outside of school. So that's been huge for a couple of students that I've been working with. Trying to change and shift that. But that requires a team effort, I've got [three staff] all of us we're all on to it all the time. (Well-being Coordinator)*

Some schools further supported students through technology by providing electronic means to assist students manage their time and by providing class lessons online, as one participant explained:

*A programme called ES progress, which looks at tracking their significant signposts of units or big assignments including personal projects and due dates. They have to reach certain targets by those due dates and if they don't an email gets sent to their parents to actually let them know that they are falling behind in their signposts that they've negotiated with their supervisor ... we've also implemented Manage Bank which is a curriculum management tool and virtual learning environment which has negated that stress if you're absent due to illness or sport or anything ... our lessons are up there available for them. (MYP Coordinator)*

## Barriers to Success

Very few barriers were mentioned by staff. This could have been due to the fact that schools were not neglecting students' well-being and they were attending to their needs, as discussed above. The barriers that were identified by staff involved factors external to the school and were associated with student and family attributes.

One barrier to success was the "perfectionism" expected by some students and their parents. As one participant explained:

*I think sometimes there is a barrier ... of needing to be a bit of a perfectionist. You know needing to be perfect and that really worries me. And something we will continue to try and work on with young people. You know "I'm disappointed because I got 99.5 and I was hoping to get 99.9". And that can be a real issue, and that's certainly something we need to work with parents on sometimes too because parents sometimes expect that "your sister got 99.95 and you only got 99.5, you sort of didn't quite make the*

*mark". And that's a bit sad. And so that can be a real barrier. And often, a young person who's aiming for perfection, if they don't quite get there they can often drop their bundle completely. (Principal)*

Student attributes that were considered a barrier to success that blocked student achievement included students' lack of self-confidence, self-discipline and poor choices. The following participants explained how these thwarted student effort:

*Some of the barriers are around self confidence and self esteem and just that ability to understand that they are capable and if they put the work in then the benefits and the results are going to come. (Head of Middle School)*

*Students do come with complex backgrounds and they come from different you know, skill sets and things like that. And trying to you know, lift the level of all students no matter where they are on that ladder, but is, I think difficult in terms of you know, getting them to have that confidence to believe in themselves when sometimes others don't believe in them. (Well-being Coordinator)*

*... self-discipline. But it's not actually really a lack of self-discipline. It's a lack of focus in deciding with what's important. Because it might be their mates, and they will be there on time and they will be ready, and they'll be organised and they'll have whatever gear that they need to go wherever it is they decide to go. If it comes to sports training, they're up pretty early. They get up at five o'clock for rowing training. Do you think they can always get to the classroom on time? So it comes down to what constitutes for them something that is a priority and an area in which it's important to be successful, and I'm not always convinced that they can see too far ahead. (MYP Coordinator)*

The relationship students had with staff as well as each other was also flagged as a possible impediment to success. This was typified in the following quotes:

*I think that some students will walk in to some classes and because of the type of relationship that they have with the teacher they may not be as successful as they could be, if they were walking into the same subject with a different teacher where they had a different relationship with them. (Head of Middle School)*

*... relationships with staff. If the kids have that personality clash in a class, it's very difficult to sort of break that. (Counsellor)*

*... relationships with the students as well. They self-select often. If they choose to friend students who are disengaged, previously engaged students may disengage as a result. (MYP Coordinator)*

*If you can build a good functional relationship with students as a teacher you certainly, you'll get more out of them and they'll come to your class and enjoy and that kind of thing. If they don't, life's hard. (MYP Coordinator)*

Students' family backgrounds were also considered possible barriers to success. For example, one participant explained that the aspirations of some students could be influenced by occupations of other family members:

*No one else in the family has been a lawyer so really it doesn't matter whether you get to that point sort of thing. I think there's certainly that. (Principal)*

Family circumstances were also thought to have an impact on students and hinder student progress towards success. Examples of situations which were out of the control of students, but which impacted them greatly included students having to care for parents, parents separating and family deaths.

*There are a few students who are caring for their parents in some capacity and taking on that caring role means the attendance isn't there for a small minority of groups, students in the class. (MYP Coordinator)*

*Home issues ... if parents are fighting or if there's a split in the family or death or anything like that, that's obviously going to affect it. (Counsellor)*

Not all students had equal access to resources and this too was considered a hindrance to success. As one participant pointed out:

*... access issues in schools. I think some kids are obviously more privileged than others and have the opportunity to access things better than others do and that's always going to be a barrier to success. (Principal)*

## Discussion

Most IB MYP students acknowledged that their school was making an effort to assist students to succeed and to succeed at goals that were non-academic as well as academic. Both students and staff conceptualised success as the achievement of goals that varied between students and that extended beyond academic achievement. School staff recognised the inextricable link between success and well-being and were able to articulate this notion more clearly than students.

Staff identified a number of enablers of success which included providing a safe and secure environment, attending to student well-being, ensuring good relationships with students and parents, empowering students, building student skills, possessing a culture of success, having a collaborative staff and supporting students with resources. Staff generally attributed external factors such as parent and student characteristics and expectations as barriers to success. This is understandable since all staff participants felt that the school was taking measures to assist students as best they could.



# Mental Health Strengths and Difficulties

---

*The SDQ provides a direct assessment of the individual internal and relational qualities identified as reflecting social and emotional well-being among children ... The SDQ was also strongly supported through the consultation process as the most appropriate measurement tool for assessing the social and emotional well-being of children. (Australian Institute of Health and Welfare (AIHW), 2012, p. 46).*

Developed by Goodman (1997) to include children's strengths rather than just deficits, the Strength and Difficulties Questionnaire (SDQ) is a popular and widely used (translated in over 60 languages) screening instrument for assessing child mental health problems. The SDQ does not provide a diagnosis of a mental disorder, but it suggests the likely presence of a mental health problem requiring further investigation. Research has shown that "children with higher total difficulty scores have successively higher probabilities of clinical disorder" (Goodman & Goodman, 2011, p. 100). The SDQ is being used across the world as a research tool in studies involving an assessment of children's mental health.

In our study the SDQ was used as an indicator of the presence of mental health problems amongst IB MYP students in the manner suggested by the AIHW (2012): As an indicator for children's health, development and well-being. In selecting the SDQ as a strong predictor of mental health problems, the AIWH recommended that the indicator for "social and emotional well-being, based on the SDQ, be defined as the proportion of children scoring 'of concern' on the Strengths and Difficulties Questionnaire" (p. 46). This is the delineation made in our study of IB MYP students based on their SDQ scores.

The SDQ is available in multi-informant versions; for parents and teachers of children aged 4-16 and as a self-report questionnaire for young people aged 11-16. We used the self-report student version in our study. The self-report SDQ has been validated and found to be reliable, and its psychometric properties have been verified (Goodman, 2001; Goodman, Meltzer, & Bailey, 2003).

## The Strengths and Difficulties Questionnaire (SDQ)

The SDQ screening instrument for mental ill-health includes five subscale measures, each comprising five items, of emotional symptoms, conduct problems, hyperactivity, peer problems and pro-social behaviour (see Appendix A for a list of items in each scale). All subscales except pro-social behaviour are summed to produce a total difficulties score, which is referred to in our study as the total SDQ score.

Items are scored as "not true" (0), "somewhat true" (1) and "certainly true" (2), although seven items in the scale are reverse scored. Scores in each subscale range from 0-10 and the total SDQ score ranges from 0-40.



The pro-social subscale is not reverse scored and included in the difficulties measure because conceptually the absence of pro-social behaviours differs from the presence of psychological difficulties (Goodman, Meltzer, & Bailey, 1998). SDQ scores can be used as continuous variables, or can be classified as being in a range that is “normal”, “borderline” or “of concern” based on cut-offs provided on the SDQ website ([www.sdqinfo.org](http://www.sdqinfo.org) - see Table 11)

**Table 11 Total SDQ and SDQ subscale cut-off scores**

Self Report SDQ	Normal	Borderline	Of Concern
Total Difficulties Score (TotSDQ)	0-15	16-19	20-40
Emotional Symptoms Score	0-5	6	7-10
Conduct Problems	0-3	4	5-10
Hyperactivity Score	0-5	6	7-10
Peer Problems Score	0-3	4-5	6-10
Prosocial Behaviour Score	6-10	5	0-4

## Mental Ill-health

A total SDQ difficulties score was calculated for each student by summing scores from all scales except the pro-social scale. The proportions of males and females categorised in the range of normal, borderline and of concern are shown in Table 12. As shown, 15.6% of males and nearly one quarter (24.0%) of the females in this IB MYP sample had total SDQ scores that fell in the “of concern” range suggesting the presence of mental ill health.

An examination of the influence of gender, year level, age, school type and SES on mental health difficulties (Total SDQ) was undertaken using a MIMIC model. The results show that gender and SES were associated with mental health difficulties while year level and school were not (see Appendix B Figure 15). Females were more likely to have high Total SDQ scores suggesting that they were more likely to be “of concern” than males. Students from low disadvantaged backgrounds were more likely than students with greater disadvantage to have low Total SDQ scores. This suggests that students with high disadvantage were more likely to have mental ill health that was “of concern”. However, once again this influence was weak, with only 9.2% of the variance in mental health difficulties attributed to these influences.

Using the cut-offs shown in Table 11, 63.6% of IB MYP were classified in the normal range, 16.7% were borderline and 19.6% were “of concern”. A comparison of male and female classifications found that males were more likely than females to have been categorised in the normal range (69.0% vs 58.0%), while females

were more likely than males to have been classified as borderline (18.0% vs 15.4%) or “of concern” (24.0% vs 15.6%). However, when males and females were divided into age groups, a comparison with Australian norm data found that, with one exception (i.e. females aged 14-16), IB MYP students’ SDQ scores fell within the normal range.

The means of the classifications for males and females aged 11-13 and 14-16 years are shown in Table 13, together with the means and standard deviations for Australian young people in a similar age range (Mellor, 2005; [www.sdqinfo.org/norms/AusNorm2.pdf](http://www.sdqinfo.org/norms/AusNorm2.pdf)). Except for females aged 14-16, all Total SDQ scores and subscale means of the IB MYP students fell within the normal range for Australian young people. The emotional symptoms score and the Total SDQ score means for IB MYP females aged 14-16 fell outside a satisfactory range for Australian females aged 14-17 (see Figure 75). The mean emotional symptoms score for IB MYP females was just outside one standard deviation of the Australian mean for this age group. As a result of this, the mean Total SDQ score for 14-16 year old IB MYP females was also outside the normal range for females of this age. This suggests that some IB MYP 14-16 year old females (in Years 9 &10) had emotional symptoms indicative of clinically significant problems which would require further exploration by mental health professionals such as counsellors or psychologists.

Table 12 Proportion of male and female IB MYP students in each category of the SDQ by age group

	SDQ Classification	Male				Female			
		Aged 11-13		Aged 14-16		Aged 11-13		Aged 14-16	
		Count	%	Count	%	Count	%	Count	%
Emotional symptoms category	normal	299	85.4	534	84.9	223	65.2	283	56.0
	borderline	22	6.3	46	7.3	40	11.7	51	10.1
	of concern	29	8.3	49	7.8	79	23.1	171	33.9
	Subtotal	350	100.0	629	100	342	100	505	100
Conduct problems category	normal	259	74	424	67.6	260	75.8	385	76.5
	borderline	38	10.9	72	11.5	36	10.5	39	7.8
	of concern	53	15.1	131	20.9	47	13.7	79	15.7
	Subtotal	350	100	627	100	343	100	503	100
Hyperactivity category	normal	243	69.2	433	68.5	220	64.7	301	59.5
	borderline	44	12.5	83	13.1	40	11.8	63	12.5
	of concern	64	18.2	116	18.4	80	23.5	142	28.1
	Subtotal	351	100	632	100	340	100	506	100
Peer problems category	normal	262	74.9	471	75	259	75.7	375	74.9
	borderline	65	18.6	121	19.3	61	17.8	85	17.0
	of concern	23	6.6	36	5.7	22	6.4	41	8.2
	Subtotal	350	100	628	100	342	100	501	100
Prosocial category	normal	261	74.1	430	68.4	312	90.4	429	85.0
	borderline	54	15.3	100	15.9	19	5.5	43	8.5
	of concern	37	10.5	99	15.7	14	4.1	33	6.5
	Subtotal	352	100	629	100	345	100	505	100
Total SDQ category	normal	235	69.7	424	68.7	212	64.2	266	53.6
	borderline	58	17.2	90	14.6	45	13.6	104	21.0
	of concern	44	13.1	103	16.7	73	22.1	126	25.4
	Subtotal	337	100	617	100	330	100	496	100

Table 13 Mean SDQ scores of male and female IB MYP Students compared to Australian norms

	Male				Female			
	IB MYP		Australian Norms		IB MYP		Australian Norms	
	11-13 years	14-16 years	11-13 years	14-16 years	11-13 years	14-16 years	11-13 years	14-16 years
Emotional symptoms	3.1 (2.2) (normal)	3.1 (2.2) (normal)	2.0 (1.9) (normal)	2.1 (2.0) (normal)	4.5 (2.6) (normal)	5.2 (2.7) (borderline)	2.6 (2.1) (normal)	2.9 (1.9) (normal)
Conduct problems	2.4 (2.4) (normal)	2.7 (2.0) (normal)	2.0 (1.8) (normal)	2.4 (1.9) (normal)	2.3 (1.9) (normal)	2.4 (1.9) (normal)	1.3 (1.5) (normal)	1.7 (1.5) (normal)
Hyperactivity	4.5 (2.1) (normal)	4.7 (2.2) (normal)	3.2 (2.3) (normal)	4.0 (2.4) (normal)	4.8 (2.3) (normal)	5.0 (2.3) (normal)	2.6 (2.2) (normal)	3.1 (2.2) (normal)
Peer problems	2.3 (1.9) (normal)	2.4 (1.9) (normal)	1.7 (1.6) (normal)	1.6 (1.6) (normal)	2.3 (1.8) (normal)	2.6 (1.7) (normal)	1.4 (1.6) (normal)	1.4 (1.4) (normal)
Pro-social	6.8 (2.0) (normal)	6.5 (2.1) (normal)	7.8 (1.9) (normal)	7.3 (1.8) (normal)	7.6 (1.7) (normal)	7.6 (1.9) (normal)	8.6 (1.4) (normal)	8.4 (1.6) (normal)
Total SDQ	12.3 (5.8) (normal)	12.8 (5.9) (normal)	8.8 (5.5) (normal)	10.1 (6.0) (normal)	13.8 (6.3) (normal)	15.2 (6.3) (borderline)	8.0 (6.1) (normal)	9.1 (4.8) (normal)

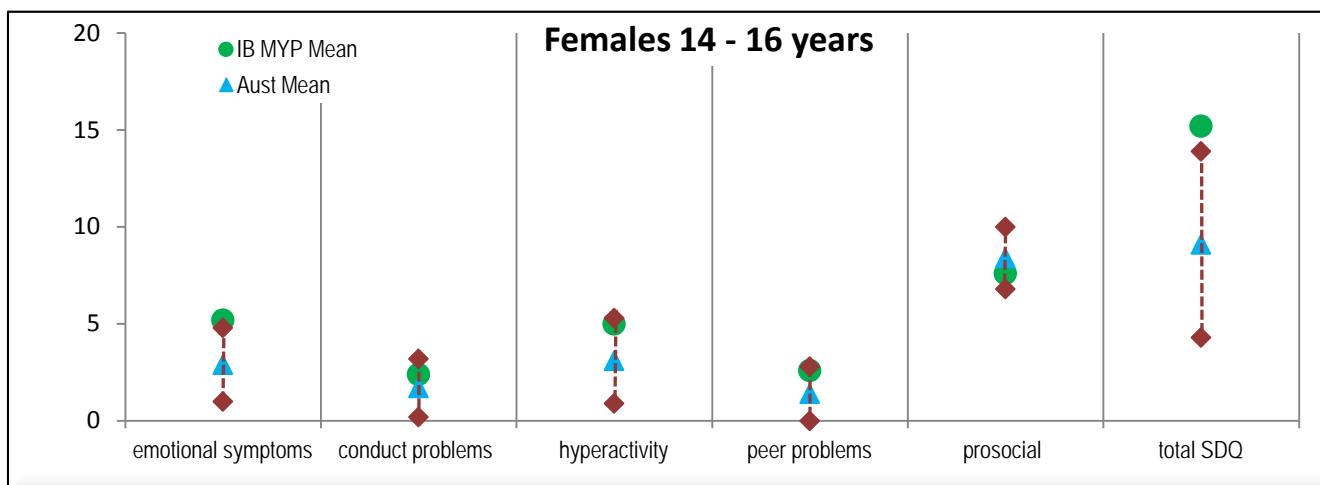

Figure 75 Mean SDQ scores of female IB MYP students compared to the Australian normal range

## Females in the Upper Years of MYP

It was evident from the responses to the open-ended question in the WBQ that some females were not faring well at school. An example of responses from four females (from different schools and SES backgrounds) aged 15 and 16, in Years 9 and 10, who had been classified as languishing based on their MentHC scores, are shown in Figure 76. These examples illustrate the disheartened emotional state of some females in the upper years of MYP. While negative feelings such as these were not provided by many of the study participants, their existence, together with the quantitative findings, suggests that depression and emotional turmoil is common amongst females in the upper years of MYP, irrespective of their socioeconomic background or the school they are attending. The sentiments expressed by these participants, who were “of concern”, clearly suggest that some females, particularly in the upper years of MYP, are experiencing mental health difficulties and would benefit from psychological and mental health support.

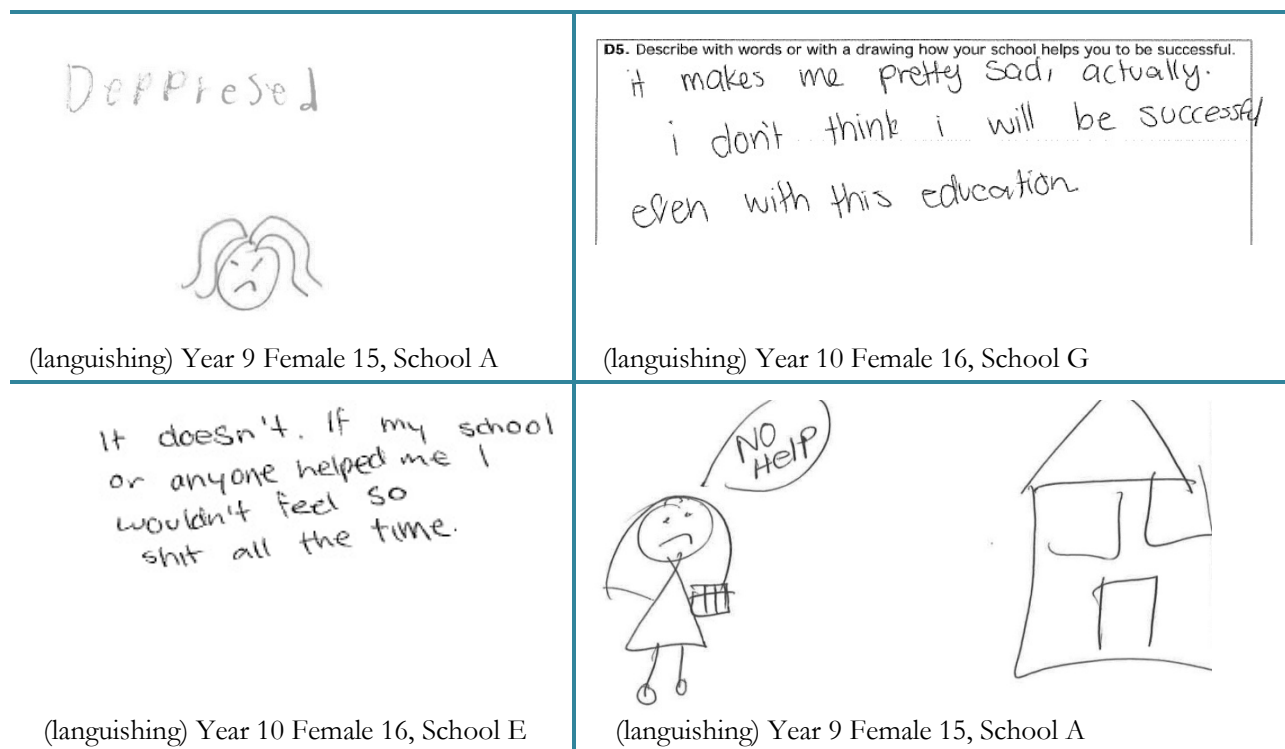

Figure 76 Examples of responses provided by females in the upper years of MYP

Further clues about the emotional disposition of some females in the upper years of MYP were provided by focus group participants. Focus group discussions with females in the upper years of MYP suggested that what others such as teachers, family and friends, thought of them was important for the development of their self-esteem and confidence.

Without positive feedback or attention from teachers and friends, some females appeared to flounder. As the females explained:

*... it's teachers [that] don't interact with you. You lose confidence and motivation and there's no sense of self-worth or self-esteem there. Like it just completely drops everything and makes you doubt everything. Like I doubt - you just sit there and go, "Well, I can't do that," you don't even look at it. You just go, "I can't do it." ... I haven't gotten a job yet because I'm that unconfident that I can't stand there and talk to people. (Female, Year 10)*

*I don't think it's just yourself, I think it's influenced by your friends and family. Like some - my friends - people will just joke around and some say, "You're better at English than you are at humanities," and it's like then when you have assignments it's like you doubt yourself because of what your friends have said. (Female, Year 9)*

*I think it's better to have them, like a couple of friends than not to have any because you feel a bit more confident, like people like you. (Female, Year 10)*

These quotes reveal the vulnerability of some females in terms of their confidence and self-esteem and this could render them susceptible to emotional problems. However, more in-depth research would be required to investigate the complexities of this phenomenon.

## Discussion

IB MYP students were generally not found to differ significantly from other Australian students of the same age in terms of their mental health difficulties. However, IB MYP females aged 14-16 proved to be the exception as they showed signs “of concern” for emotional symptoms and overall mental ill health. In light of the responses shown in Figure 76, it is not likely that this finding is associated with measurement error. Even when special needs students were removed from the sample and the data re-analysed, the proportion of females who were “of concern” remained high. It is not known why IB MYP females would be experiencing mental health difficulties and emotional symptoms in particular. Further research would be required to explore the possible causes of the negative feelings being experienced by some 14-16 year old females. A negative perspective may be associated with transitioning through puberty and negotiating pressures associated with body image and appearance (Clay, Vignoles, & Dittmar, 2005), although other Australian 14-16 year old females would have been exposed to similar socio-cultural and media driven pressures. It may be that (unknown) factors associated with the socio-cultural background of some females in our study has increased the likelihood of emotional volatility, but further research would be required to inform these speculations.

While the SDQ has been validated and it is widely used in its various forms across the world, it has not been without criticism. CFAs of the SDQ in Australia (parent, teacher and youth SDQ) found that the models based on the five factors did not show acceptable model fit (Mellor & Stokes 2007). According to Goodman,

Lamping, & Ploubidis (2010) this suggests that the SDQ subscales “may not all tap into distinct aspects of child mental health” (p. 1187) particularly for low risk groups, such as IB MYP students. They advised combining items in the SDQ to produce broader internalising and externalising subscales which they would consider to be more appropriate for low-risk samples. However, comparative Australian norms were not available for this use of the SDQ. We chose therefore to use the same approach as that used by Mellor (2005) so that comparisons would be possible.

In summary then, it is not known why IB MYP females would be experiencing mental health difficulties and emotional symptoms in particular. Further research would be required to explore the possible causes of the negative feelings being experienced by some 14-16 year old females. The present findings would suggest that it would be very worthwhile to investigate this matter further.

# Summary and Conclusion

---

## The Well-being of IB MYP Students

Using three different measures we were able to determine the well-being of IB MYP students in South Australian schools. Diener et al.'s (2009) Flourishing Scale and Keyes's (2006) Mental Health Continuum enabled two separate measures of flourishing, each using different indicators, while Keyes's (2006) Mental Health Continuum and Liddle and Carter's (2010) Stirling Children's Well-being Scale enabled measures of languishing and poor mental health. The scales also permitted measures of moderate mental health, positive outlook and emotional states of IB MYP students in our study. These findings are summarised below.

### IB MYP Students Flourishing

Our first measure of well-being involved a measure of psychological flourishing (Diener et al.'s (2009) 8-item Flourishing Scale). Using this scale we assigned a cut-off FloS score of 40 so that students with a score of 41 or more were classified as "flourishing". Just over half (55.3%) of IB MYP students were classified as flourishing using this method (see Table 14). We then turned to Keyes's (2006) Mental Health Continuum Scale and following his instructions of identifying students with at least one hedonic and at least six eudaimonic functions, we identified 48.5% of IB MYP students as "flourishing". However, we found that if we used items from Keyes's MentHC to derive a "flourishing" latent variable that the proportion identified as flourishing was 54.1% (see Table 14). This proportion was in accord with that derived from Diener et al.'s FloS scores. We surmised that a "flourishing" latent variable that fit the data well and that included all available information rather than a minimum count would be a more accurate measure of flourishing. Thus given the agreement between measures, we concluded that just over half (54% - 55%) of IB MYP students were flourishing.

As discussed in chapter 4, comparisons of the proportion of IB MYP students who were identified as flourishing with those found to be flourishing in a study by Venning et al. (2012) of South Australian youths and Keyes (2006) of American youth of similar age, must be accepted with caution. Since the likelihood of flourishing has been found to decrease with age (Venning et al., 2012), well-founded comparisons can only be made with samples of students that do not differ significantly with age.



**Table 14 Summary of well-being findings**

Measure		Total Proportion	Males	Females
<b>Flourishing Scale</b> (Diener et al.)	Flourishing (FloS)	55.3%	59.8%	50.9%
<b>Mental Health Continuum</b> (Keyes) (Composite measure)	Flourishing (MentHC)	54.1%	59.7%	47.8%
	Moderate Mental Health (MentHC)	39.7%	36.0%	44.0%
	Languishing (MentHC)	6.1%	4.4%	8.1%
<b>Stirling Children's Well-being Scale</b> (Liddle & Carter)	Poor mental health (StirCWB)	8.4%	5.2%	12.0%
	Positive Emotional State (StirCWB) - always	52.4%	58.3%	45.8%
	- sometimes	32.2%	27.6%	37.4%
	Positive Outlook (StirCWB) - always	60.1%	66.9%	52.4%
	- sometimes	35.6%	33.1%	38.4%

## IB MYP Students Languishing

Keyes (2006) has suggested there is a continuum of well-being whereby some individuals may be experiencing psychological difficulties and strain, yet do not have a diagnosed mental illness. These individuals with compromised well-being are described as languishing and they were identified by Keyes as experiencing at least one hedonic and six eudaimonic functions infrequently (“once or twice” or “never”). In our study we found that 8% of IB MYP students could be categorised as languishing (see Table 14).

The Stirling Child Well-being Scale also provided an indirect measure of psychological difficulties. Liddle and Carter (2010) suggested that StirCWB scores that were less than 30 were an indication of poor mental health. In our study we found that 8.4% of IB MYP students had scores in this lower range. This proportion accords well with the number determined to be languishing (8%) using Keyes’s MentHC. Based on these results we would conclude that about 8% of IB MYP students were languishing.

Although 6% of youths in Keyes’s (2006) study were identified as languishing, comparisons are difficult since participants were not matched in age.

## IB MYP Students with Moderate Mental Health

Individuals with moderate mental health were identified by Keyes (2006) as those who were not categorised as either flourishing or languishing. Using this method we found that just over two in five (43.5%) of IB MYP students could be described as having moderate mental health. Once again, for the reasons stated above, comparisons with youths studied in similar research were not possible.

## IB MYP Students with a Positive Outlook and a Positive Emotional State

The Stirling Children’s Well-being Scale comprises two subscales which measure positive outlook and a positive emotional state. Using factor score coefficients, we found that over half (60.1%) of IB MYP students were experiencing a positive outlook and just over half (52.4%) were experiencing a positive emotional state “quite a lot” or “all of the time”. These proportions of positive states of being are comparable with those in our study that were found to be flourishing (54%-55%).

## IB MYP Student Profile

In our study we also examined student attributes considered to have been associated with well-being. These included cognitive and affective empathy, global self-concept, self-reflection, relationships and resilience. The results of an examination of these student characteristics and their link to well-being are summarised in this section.

### Cognitive Empathy

Cognitive empathy has been described as an intellectual understanding of another person’s perspective and feelings that is associated with taking another’s perspective. It has been suggested that this type of empathy is associated with the likelihood of bullying others (Sutton et al., 1999). In our study nearly two in five (39.4%) IB MYP students reported that indicators of cognitive empathy were “very” or “fairly like” them. Further analyses found that high levels of cognitive empathy were associated with low levels of well-being as measured by FloS, MentHC and StirCWB Scales, although it was generally a poor predictor of well-being. In addition, we found that the presence of cognitive empathy was associated with the likelihood of involvement in bullying as a victim or bully. We have concluded that cognitive empathy is not a desirable attribute to *solely* promote for well-being.

### Affective Empathy

In contrast to cognitive empathy, affective empathy is the ability to share in another person’s feelings and show empathic concern for another (Cotton, 2001). In our study, just over half (52.2%) IB MYP students reported that the descriptors of affective empathy were “very” or “fairly like” them. This suggests that school attempts to develop empathy in students through various programmes and strategies appear to have been effective. Regression analyses found that affective empathy was not a good predictor of well-being, which was measured using FloS, MentHC and StirCWB, indicating that the presence of affective empathy is not associated with high levels of well-being. Affective empathy was found to be a negative predictor of involvement in bullying as a victim or a bully. Based on these findings we would suggest that affective

empathy is an important aspect of empathy and should be concomitant with cognitive empathy but it is not an important factor for good well-being.

## Global Self-concept

While it is debatable whether global self-concept is a good proxy measure for “balance”, more than half (60.1%) IB MYP students reported a positive sense of global self-concept “always” or “most of the time”. The global self-concept model used in SEM regression analyses with each of the well-being measures used in our study (FloS, MentHC and StirCWB) found that it was a significant predictor of well-being. Global self-concept was a significant predictor of flourishing, suggesting that students with high levels of global self-concept were the most likely to be flourishing. Similarly, global self-concept was a significant predictor of the components of well-being comprising the MentHC and it significantly predicted emotional, psychological and social well-being. The analyses suggest that global self-concept may be an important element in social well-being, having a positive outlook and a positive emotional state. We would suggest that actions currently being taken by schools to enhance the global self-concept of students should be intensified and steps taken to ensure that all students are included in strategies designed to improve student confidence and self-esteem.

## Self-Reflection

Being reflective is an IB Learner Profile attribute and nearly three-quarters (74.6%) of IB MYP students in our sample indicated that they were engaging in self-reflection. However, our analyses found that self-reflection, without insight and self-acceptance, does not significantly influence well-being. We would recommend that schools develop plans, such as implementing mindfulness techniques (see Burke, 2009) to assist students to use reflection more positively and effectively.

## Resilience

Resilience is inherent in the IB MYP as it seeks to advance a self-regulated learner to effectively deal with and respond positively to any setbacks and difficulties, and to make changes and persevere. In our study we found that just over half (53.3%) of IB MYP students reported they felt resilient “often” or “nearly all the time” and our SEM analyses indicated that resilience was a good predictor of well-being. We found that resilience was associated with flourishing, social, emotional and psychological well-being, as well as having a positive outlook and a positive emotional state. The more resilient the student, the more likely they were to exhibit these facets of well-being. While the development of resilience in schools was not investigated in our study, studies by other researchers (Oliver et al., 2006) suggested that meaningful involvement of students in decision making involving them promotes resilience. This approach is worthy of consideration if schools wish to develop resilience and well-being amongst students.

## Relationships

A SEM regression analysis found that the relationship factor was a significant predictor of well-being, as measured by FloS, MentHC, and StirCWB. The relationship factor was associated with large amounts of variance in flourishing, social, emotional and psychological well-being, as well as having a positive emotional state and a positive outlook. The findings suggest that friendships, being pro-social as well as positive relationships at school are important factors for well-being. The qualitative findings support these results and we suggest that schools continue to ensure positive relationships abound between students as well as between students and teachers.

## IB MYP Student Satisfaction with School

Our measures of student satisfaction with school indicated that most IB MYP students were happy (approximately 70%) and satisfied (approximately 80%) with school. We found that most IB MYP students reported that they enjoyed school (72.0%), enjoyed learning (69.7%), felt supported by their school (70.8%) and had a sense of fellowship at school (80.1%). Our results showed that school satisfaction was important for well-being as it influenced the likelihood of flourishing, having a positive outlook and a positive emotional state, as well as social, emotional and psychological well-being. Nearly one in five (19.2%) of IB MYP students reported being bullied once a week or more often and this number was lower than the 22.7% of South Australian students of similar age reported in a study by Slee (2005).

## School Success Practices

IB MYP students generally acknowledged that their school was making an effort to assist students to succeed at goals identified as important to students. Both students and staff conceptualised success as the achievement of goals that varied between students and extended beyond academic achievement per se. School staff clearly recognised the inextricable link between success and well-being and they identified a number of enablers of success. These included providing a safe and secure environment, attending to student well-being, ensuring good relationships with students and parents, empowering students, building student skills, possessing a culture of success, having a collaborative staff and supporting students with resources. Staff generally attributed factors independent of the school, such as parent and student characteristics and expectations, as barriers to success. We would suggest that schools continue to build success practices that address student needs.

## Mental Ill-health

The Strengths and Difficulties Questionnaire (SDQ, Goodman, 1997) was used as a screening instrument to identify likely mental ill health amongst students. Our results found that except for females aged 14-16, IB MYP students did not differ significantly from the Australian norms for mental health difficulties. However, for a small group of females in the upper years of MYP, emotional symptoms and total SDQ scores were “of concern” as these scores fell outside one standard deviation of the Australian means for this age group of females. It is not known why females would be experiencing these emotional difficulties and more research would be required to explore this further.

## Gender Differences

Male and female IB MYP students were found to differ on nearly all measures included in the WBQ (see Table 14). There were some exceptions however. Areas in which males and females showed no significant difference included self-reported levels of serious bullying, in their relationships and in their general happiness at school. Males and females did not differ in their enjoyment of school, in their enjoyment of learning and in their sense of fellowship at school.

Overall, males outscored females on all well-being measures. Males were more likely than females to flourish, to have a positive outlook and a positive emotional state, while females were more likely to languish or have moderate mental health.

Compared to males, females showed greater levels of cognitive and affective empathy and self-reflection, but males were generally more resilient and had higher global self-concept scores. Males were more likely to report school satisfaction and this was associated with males reporting that they felt supported by their school more than females.

Gender intensification theory proposed by Hill and Lynch (1983) suggests that differences between males and females are to be expected during the middle years as stereotypical gender behaviours are adopted by pubescent adolescents. How stereotypical masculine and feminine behaviours relate to well-being is a topic worthy of exploration in future research.

## Differences Between Year Levels

Differences between IB MYP students at different Year levels were apparent across all measures in the WBQ. Students in the lower years of MYP (Years 6 & 7) generally showed greater levels of well-being than students in the upper years of MYP. These students were more likely to have been flourishing, to have a positive outlook and a positive emotional state than older students. However, while younger students reported higher

levels of cognitive and affective empathy, the differences were significant only between Year 6s and other year levels. Following a drop in Year 7, cognitive and affective empathy were relatively stable across the middle years.

Younger students also reported higher levels of global self-concept, self-reflection, resilience, positive relationships, and school satisfaction than older students. However, reports of being bullied once a week or more often was also higher in the lower years of MYP than in the upper years of MYP.

Our results are in accord with Venning et al.'s (2012) well-being study of South Australian adolescents. They found that the likelihood of flourishing was lower in older adolescents, although languishing was relatively stable across ages 13-17.

## Females in the Upper Years of MYP

An interaction effect of gender and year level was evident in many of the well-being measures in our study and quite often it was apparent that this effect was associated with the state of being of some females in the upper years of MYP. Generally, compared to younger females and males, females in the upper years of MYP were more likely to be languishing and less likely to be flourishing, but more likely to have moderate mental health. In our study, females in the upper years of MYP tended to have the lowest scores on measures of positive outlook, a positive emotional state, global self-concept, relationships and resilience. Females in the upper years of MYP were also more likely to show signs of emotional symptoms that were “of concern”. Our study also found qualitative evidence to suggest that some females in the upper years of MYP were not faring well; feeling depressed, disheartened and unsupported by their school. Our study suggests that the social and emotional disposition of females should be monitored across the upper years of MYP and appropriate interventions initiated where they are deemed necessary. It is not known why older IB MYP females in our study showed signs of poorer mental health and further research would be required to explore the possible causes of the negative feelings being experienced by some 14-16 year old IB MYP females.

## Limitations

Our study is not without limitations. While we endeavoured to find a representative sample of IB MYP students using maximum variation sampling, representation of students from low SES backgrounds was not sufficient. Our findings are more likely to reflect the social circumstances of students from middle and upper SES groups. However, it is not clear whether such a group is representative of IB MYP students in South Australia, where the IB MYP is available in schools that cater to students from low socio-economic status. Nonetheless, our findings should be generalised with caution.

The data for this study was generated from self-reports and while some self-report forms have been found to be reliable and valid (e.g. Goodman's (2001) SDQ), and it can be predicted that students would be good informants about their own feelings and subjective well-being, future research could triangulate assessments from other informants such as teachers and parents/guardians.

Study data were gathered from a cross-section of respondents at a single point in time, so any inferences of cause-and-effect relationships cannot be considered definitive (Creswell, 2012). Future studies could contribute to our understanding of changes in student well-being across the middle years by undertaking a longitudinal study with the same respondents, over a number of years.

# References

---

- Anderson, J. C., & Gerbing, D. W. (1988). Structural Equation Modeling in practice: A review and recommended two-step approach. *Psychological Bulletin*, *103*, 411-423.
- Andreou, E. (2004). Bully/victim problems and their association with machiavellianism and self-efficacy in Greek primary school children. *British Journal of Educational Psychology*, *74*, 297-309.
- Askill-Williams, H., & Cefai, C. (2014). Australian and Maltese teachers' perspectives about their capabilities for mental health promotion in school settings. *Teaching and Teacher Education (online early)*. doi: 10.1016/j.tate.2014.02.003
- Asparouhov, T. (2005). Sampling Weights in Latent Variable Modeling. *Structural Equation Modeling*, *12*(3), 411-434.
- Australian Bureau of Statistics (ABS). (2008). Census of Population and Housing: Socio-Economic Indexes for Areas (SEIFA), Australia - 2033.0.55.001. Canberra, Australia: Australian Bureau of Statistics.
- Australian Institute of Health and Welfare (AIHW). (2012). Social and emotional wellbeing: Development of a children's headline indicator. Canberra: Australian Institute of Health and Welfare.
- Blair, R. J. R. (2005). Responding to the emotions of others: Dissociating forms of empathy through the study of typical and psychiatric populations. *Conscious Cognition*, *14*, 698-718. doi: 10.1016/j.concog.2005.06.004
- Bonanno, G. A. (2004). Loss, trauma, and human resilience. *American Psychologist*, *59*, 20-28.
- Boulton, M. J., & Underwood, K. (1992). Bully/victim problems among middle school children. *British Journal of Educational Psychology*, *62*, 73-87.
- Bradley, R. H., & Corwyn, R. F. (2002). Socioeconomic status and child development. *Annual Review of Psychology*, *53*, 371-399.
- Brown, T. A. (2006). *Confirmatory Factor Analysis for applied research*. New York: The Guilford Press.
- Browne, M. W., & Cudeck, R. (1993). Alternate ways of assessing model fit. . In K. A. Bollen & J. S. Long (Eds.), *Testing structural equation models* (pp. 136-162). Newbury Park, CA: Sage.
- Brunner, M., & Heinz-Martin, S. (2005). Analyzing the reliability of multidimensional measures: An example from intelligence research. *Educational and Psychological Measurement*, *65*, 227-240.



- Buchanan, K. E., & Bardi, A. (2010). Acts of kindness and acts of novelty affect life satisfaction. *Journal of Social Psychology, 150*, 235-237.
- Burke, C. A. (2009). Mindfulness-based approaches with children and adolescents: A preliminary review of current research in an emergent field. *Journal of Child and Family Studies, 19*, 133-144.
- Camfield, L., Streuli, N., & Woodhead, M. (2009). What's the use of 'wellbeing' in contexts of child poverty? Approaches to research, monitoring and children's participation. *International Journal of Children's Rights, 17*, 65-109.
- Campbell-Sills, L., & Stein, M. B. (2007). Psychometric analysis and refinement of the Connor–Davidson Resilience Scale (CD-RISC): Validation of a 10-Item measure of resilience. *Journal of Traumatic Stress, 20*(6), 1019–1028. doi: 10.1002/jts.20271
- Cohen, J. (1992). A power primer. *Psychological Bulletin, 112*, 155-159.
- Cohen, P., Cohen, J., Teresi, J., Marchi, M., & Velez, C. N. (1990). Problems in the Measurement of Latent Variables in Structural Equations Causal Models. *Applied Psychological Measurement 14*, 183-196.
- Connor, K. M., & Davidson, R. T. (2003). Development of a new resilience scale: The Connor-Davidson Resilience Scale (CD-RISC). *Depression and Anxiety, 18*, 76-82.
- Cotton, K. (2001). Developing Empathy in Children and Youth. *School Improvement Research Series: Research You Can Use, Close-Up #13*, from [http://educationnorthwest.org/webfm\\_send/556](http://educationnorthwest.org/webfm_send/556)
- Creswell, J. (2012). *Educational Research*. Boston, MA: Pearson
- Cross, D., Shaw, T., Hearn, L., Epstein, M., Monks, H., Lester, L., & Thomas, L. (2009). Australian Covert Bullying Prevalence Study (ACBPS). Perth: Child Health Promotion Research Centre, Edith Cowan University.
- Currie, C., Zanotti, C., Morgan, A., Currie, D., de Looze, M., Roberts, C., . . . Barnekow, V. (2012). Health behaviour in school-aged children (HBSC) study: International report from the 2009/2010 survey (*Health Policy for Children and Adolescents, No. 6*). Copenhagen: WHO Regional Office for Europe.
- Damon, W. (2004). What is positive youth development? *Annals of the American Academy of Political and Social Science, 591*, 13-24.
- Darling, N., Caldwell, L. L., & Smith, R. (2005). Participation in school-based extracurricular activities and adolescent adjustment. *Journal of Leisure Research, 37*, 51-76.
- Denny, S., Fleming, T., Watson, P., Ameratunga, S., Robinson, E., Utter, J., . . . Schaaf, D. (2008). Youth'07: The Health and Wellbeing of Secondary School Students in New Zealand. Technical Report. Auckland, New Zealand: Adolescent Health Research Group, The University of Auckland.

- Department for Education and Child Development (DECD). (2013). Principles of the Learner Wellbeing Framework Adelaide, SA: DECD, South Australian Government.  
[http://www.decd.sa.gov.au/learnerwellbeing/files/links/link\\_72840.pdf](http://www.decd.sa.gov.au/learnerwellbeing/files/links/link_72840.pdf).
- Diener, E., & Seligman, M. E. P. (2002). Very happy people. *Psychological Science*, *13*, 81-84.
- Diener, E., Wirtz, D., Biswas-Diener, R., Tov, W., Kim-Prieto, C., Choi, D., & Oishi, S. (2009). New Measures of Well-Being. *Social Indicators Research Series*, *39*, 247-266. doi: 10.1007/978-90-481-2354-4 12
- Diener, E., Wirtz, D., Tov, W., Kim-Prieto, C., Choi, D., Oishi, S., & Biswas-Diener, R. (2010). New well-being measures: Short scales to assess flourishing and positive and negative feelings. *Social Indicators Research*, *97*, 143-156. doi: DOI 10.1007/s11205-009-9493-y
- Dijkstra, J. K., Lindenberg, S., & Veenstra, R. (2007). Same-gender and cross-gender peer acceptance and peer rejection and their relation to bullying and helping among preadolescents: Comparing predictors from gender-homophily and goal-framing approaches. *Developmental Psychology*, *43*, 1377-1389.
- Dodge, R., Daly, A. P., Huyton, J., & Sanders, L. D. (2012). The challenge of defining wellbeing. *International Journal of Wellbeing*, *2*(3), 222-235. doi: 10.5502/ijw.v2i3.4
- Dotterer, A. M., McHale, S. M., & Crouter, A. C. (2007). Implications of out-of-school activities for school engagement in African American adolescents. *Journal of Youth and Adolescence*, *36*, 391-401.
- Dunn, E. W., Aknin, L. B., & Norton, M. I. (2008). Spending money on others promotes happiness. *Science*, *319*, 1687-1688.
- Durlak, J. A., Weissberg, R. P., Dymnicki, A. B., Taylor, R. D., & Schellinger, K. B. (2011). The impact of enhancing students' social and emotional learning: A meta-analysis of school-based universal interventions. *Child Development*, *82*(1), 405-432. doi: 10.1111/j.1467-8624.2010.01564.x
- Eccles, J. S., & Barber, B. L. (1999). Student council, volunteering, basketball, or marching band: What kind of extracurricular involvement matters? *Journal of Adolescent Research*, *14*, 10-43.
- Eisenberg, N., & Lennon, R. (1983). Sex differences in empathy and related capacities. *Psychological Bulletin*, *94*, 100-131. doi: 10.1037/0033-2909.94.1.100
- Eisenberg, N., & Strayer, J. (1987). *Empathy and its Development*. Cambridge, UK: Cambridge University Press.
- Field, A. (2005). *Discovering statistics using SPSS (2nd edition)*. London: Sage.
- Field, A. (2009). *Discovering statistics using SPSS (3rd edition)*. London: Sage.
- Fredricks, J. A., & Eccles, J. S. (2006). Is extracurricular participation associated with beneficial outcomes? Concurrent and longitudinal relations. *Developmental Psychology*, *42*, 698-713.

- Fredricks, J. A., & Eccles, J. S. (2008). Participation in extracurricular activities in the middle school years: Are there developmental benefits for African American and European American youth? *Journal of Youth and Adolescence, 37*, 1029-1043.
- Fredrickson, B. L. (2001). The role of positive emotions in positive psychology: The broaden-and-build theory of positive emotions. *American Psychologist, 56*, 218-226.
- Gadbois, S., & Bowker, A. (2007). Gender differences in the relationships between extracurricular activities participation, self-description, and domain-specific and general self-esteem. *Sex Roles, 56*, 675-689.
- Garnezy, N. (1991). Resiliency and vulnerability to adverse developmental outcomes associated with poverty. *American Journal of Behavioral Science, 34*, 416-430.
- Garton, A. F., & Gringart, E. (2005). The development of a scale to measure empathy in 8- and 9-year old children. *Australian Journal of Education and Developmental Psychology, 5*, 17-25.
- Gazelle, H., & Druhen, M. J. (2009). Anxious solitude and peer exclusion predicts social helplessness, upset affect, and vagal regulation in response to behavioral rejection by a friend. *Developmental Psychology, 45*, 1077-1096.
- Georgiou, S. N., & Stavrinides, P. (2008). Bullies, victims, and bully- victims: Psychosocial profiles and attribution styles. *School Psychology International, 29*, 574-589.
- Gibb, C. (2003). Fighting childhood aggression. *The Changemakers Review, 5*(5), 14-18.
- Gini, G., Albiero, P., Benelli, B., & Altoe, G. (2007). Does empathy predict adolescents' bullying and defending behavior? *Aggressive Behavior*(33), 1-10.
- Goodman, A., & Goodman, R. (2011). Population mean scores predict child mental disorder rates: validating SDQ prevalence estimators in Britain. *Journal of Child Psychology and Psychiatry, 52*(1), 100–108. doi: 10.1111/j.1469-7610.2010.02278.x
- Goodman, A., Lamping, D. L., & Ploubidis, G. B. (2010). When to use broader internalising and externalising subscales instead of the hypothesised five subscales on the Strengths and Difficulties Questionnaire (SDQ): Data from British parents, teachers and children. *Journal of Abnormal Child Psychology, 38*, 1179-1191. doi: DOI 10.1007/s10802-010-9434-x
- Goodman, R. (1997). The Strength and Difficulties Questionnaire: A research note. *Journal of Child Psychology and Psychiatry, 38*, 581-586.
- Goodman, R. (2001). Psychometric properties of the Strengths and Difficulties Questionnaire. *Journal of the American Academy of Child and Adolescent Psychiatry, 40*, 1337-1345.

- Goodman, R., Meltzer, H., & Bailey, V. (1998). The Strengths and Difficulties Questionnaire: A pilot study on the validity of the self-report version. *European Child & Adolescent Psychiatry*, 7, 125-130.
- Grant, A. M., Franklin, J., & Langford, P. (2002). The self-reflection and insight scale: A new measure of private self-consciousness. *Social Behavior and Personality*, 30(8), 821-836.
- Green, H., McGinnity, A., Meltzer, H., Ford, T., & Goodman, R. (2005). *Mental health of children and young people in Great Britain, 2004*. London: Office of National Statistics, Palgrave Macmillan.
- Greene, S., Williams, J., Layte, R., Doyle, E., Harris, E., McCrory, C., . . . Whelan, C. T. (2010). Growing Up in Ireland, National Longitudinal Study of Children: Background and conceptual framework. Dublin, Ireland: Office of the Minister for Children and Youth Affairs, Department of Health and Children.
- Hancock, G. R., & Mueller, R. O. (2001). Rethinking construct reliability within latent variable systems. In R. Cudeck, S. D. Toit & D. Soerboom (Eds.), *Structural equation modeling: Present and future-A festschrift in honor of Karl Jöreskog* (pp. 195-216). Lincolnwood, IL: Scientific Software International.
- Hannah, L. (2011). *Exploring the Implications of Sel (SEL) and mindfulness for the IB curriculum, Assessment and Leadership*. Paper presented at the IB World Head Conference, Singapore.
- Harrington, R., & Loffredo, D. A. (2010). Insight, rumination, and self-reflection as predictors of well-being. *The Journal of Psychology: Interdisciplinary and Applied*, 145(1), 39-57. doi: 10.1080/00223980.2010.528072
- Hill, J. P., & Lynch, M. E. (1983). The intensification of gender-related role expectations during early adolescence. In J. Brooks-Gunn & A. C. Petersen (Eds.), *Girls at puberty* (pp. 201-228). New York, NY: Plenum Press.
- Hoffman, M. L. (2000). *Empathy and moral development*. Cambridge: Cambridge University Press.
- Holmes-Smith, P., & Rowe, K. J. (1994). *The development and use of congeneric measurement models in school effectiveness research: Improving the reliability and validity of composite and latent variables for fitting multilevel and Structural Equation Models*. Paper presented at the International Congress for School Effectiveness and Improvement. The World Congress Centre, Melbourne, Australia, January 3rd - 6th.
- Howell, A. J., Keyes, C. L. M., & Passmore, H. (2013). Flourishing among children and adolescents: Structure and correlates of positive mental health, and interventions for its enhancement. In C. Proctor & P. A. Linley (Eds.), *Research, applications, and interventions for children and adolescents: A positive psychology perspective* (pp. 59-79). Dordrecht: Springer Science.
- Hox, J. J., & Bechger, T. M. (1998). An introduction to Structural Equation Modeling. *Family Science Review*, 11, 354-373.

- Huppert, F. A. (2009). Psychological well-being: Evidence regarding its causes and consequences. *Applied Psychology: Health and Well-being*, 1(2), 137-164.
- International Baccalaureate Organization. (2013). MYP: From principles into practice (Draft): International Baccalaureate Organization.
- James, H. S., Jr. (2011). Is the just man a happy man? An empirical study of the relationship between ethics and subjective well-being. *Kyklos*, 64, 193-212.
- Jolliffe, D., & Farrington, D. P. (2006). Examining the relationship between low empathy and bullying. *Aggressive Behavior*, 32, 540-550.
- Kazdin, A. (1993). Adolescent mental health: Prevention and treatment programs. *American Psychologist*, 48, 127-141.
- Keyes, C. L. M. (2002). The mental health continuum: From languishing to flourishing in life. *Journal of Health and Social Behavior*, 43, 207-222.
- Keyes, C. L. M. (2005). The subjective well-being of America's youth: Toward a comprehensive assessment. *Adolescent and Family Health*, 4, 3-11.
- Keyes, C. L. M. (2006). Mental health in the CDS youth: Is America's youth flourishing? *American Journal of Orthopsychiatry*, 76(3), 395-402.
- Keyes, C. L. M., Wissing, M., Potgieter, J. P., Temane, M., Kruger, A., & van Rooy, S. (2008). Evaluation of the Mental Health Continuum Short Form (MHC-SF) in Setswana speaking South Africans. *Clinical Psychology & Psychotherapy*, 15, 181-192.
- Kline, R. B. (2011). *Principles and practice of Structural Equation Modeling, 3rd edition*. New York: The Guilford Press.
- Kokkinos, C. M., & Kipritsi, E. (2012). The relationship between bullying, victimization, trait, emotional intelligence, self-efficacy and empathy among preadolescents. *Social Psychology of Education* 15, 41-58. doi: 10.1007/s11218-011-9168-9
- Kuter, K., & Deom, G. (2013). *Status of girls in Indiana 2013*. Notre Dame, Indiana: Saint Mary's College
- Lamers, S. M. A., Westerhof, G. J., Bohlmeijer, E. T., ten Klooster, P. M., & Keyes, C. L. M. (2010). Evaluating the psychometric properties of the Mental Health Continuum-Short Form (MHC-SF). *Journal of Clinical Psychology*, 67, 99-110.
- Lau, M., & Bradshaw, J. (2010). Child Well-being in the Pacific Rim. *Child Indicator Research*, 3, 367-383. doi: 10.1007/s12187-010-9064-4

- Le, B. M., Impett, E. A., Kogan, A., Webster, G. D., & Cheng, C. (2013). The personal and interpersonal rewards of communal orientation. *Journal of Social and Personal Relationships, 30*, 694-710. doi: 10.1177/0265407512466227
- Liddle, I., & Carter, G. (2010). Emotional and psychological wellbeing in children: The standardisation of the Stirling Children's Wellbeing Scale. Scotland: Stirling Council Educational Psychology Service.
- Little, R. J. A. (1988). A Test of Missing Completely at Random for Multivariate Data with Missing Values. *Journal of the American Statistical Association, 83*(404), 1198-1202.
- Luthar, S. S., Cicchetti, D., & Becker, B. (2000). The construct of resilience: A critical evaluation and guidelines for future work. *Child Development, 71*, 543-562.
- Lyke, J. A. (2009). Insight, but not self-reflection, is related to subjective well-being. *Personality and Individual Differences, 46*, 66-70.
- Lyubomirsky, S., Sheldon, K. M., & Schkade, D. (2005). Pursuing happiness: The architecture of sustainable change. *Review of General Psychology, 9*, 111-131.
- Marsh, H. W. (1990). *SDQ manual: self-description questionnaire*. Macarthur, Australia: University of Western Sydney, Australia.
- McClave, J. T., Benson, P. G., & Sincich, T. (2005). *Statistics for business and economics. 9th edition*. Upper Saddle River, N.J., USA: Pearson Education
- Mehrabian, A. (2000). Beyond IQ: Broad-based measurement of individual success potential or "emotional intelligence". *Genetic, Social, and General Psychology Monographs, 126*, 133-239.
- Meier, S., & Stutzer, A. (2004). Is volunteering rewarding in itself? Evidence from a natural experiment (CREMA Working Paper Series). Basel, Switzerland: Center for Research in Economics, Management and the Arts (CREMA).
- Mellor, D. (2005). Normative data for the Strengths and Difficulties Questionnaire in Australia. *Australian Psychologist, 40*, 215-222.
- Mellor, D., Hayashi, Y., Firth, L., Stokes, M., Chambers, S., & Cummins, R. (2008). Volunteering and well-being: Do self-esteem, optimism, and perceived control mediate the relationship? *Journal of Social Service Research, 34*(4), 61-70.
- Mercer, S. H., & DeRosier, M. E. (2008). Teacher preference, peer rejection, and student aggression: A prospective study of transactional influence and independent contributions to emotional adjustment and grades. *Journal of School Psychology, 46*, 661-685.

- Miller, P. A., & Eisenberg, N. (1988). The relation of empathy to aggressive and externalizing/ antisocial behaviour. *Psychological Bulletin*, *103*, 324-344.
- Mor, N., & Winquist, J. (2002). Self-focused attention and negative affect: A meta-analysis. *Psychological Bulletin*, *128*, 638-662.
- Muthén, L. K., & Muthén, B. O. (2009). *MPlus User's Guide. 5th Edition*. Los Angeles, CA: Muthén & Muthén.
- Nangle, D. W., & Erdley, C. A. (2001). Editors' notes. In D. W. Nangle, C. A. Erdley & W. Damon (Eds.), *New directions for child and adolescent development. The role of friendship in psychological adjustment* (Vol. 91, pp. 1-4). San Francisco: Jossey-Bass.
- Nesdale, D., & Lambert, A. (2007). Effects of experimentally manipulated peer rejection on children's negative affect, self-esteem, and maladaptive social behavior. *International Journal of Behavioral Development*, *31*, 115-122.
- Newman, B. M., & Newman, P. R. (2012). *Development through life: A psychosocial approach*. Belmont, CA: Wadsworth.
- O'Hare, W. P., & Gutierrez, F. (2012). The use of domains in constructing a comprehensive composite index of child wellbeing. *Child Indicators Research*. doi: 10.1007/s12187-012-9138-6
- Oberle, E., Schonert-Reichl, K. A., & Thomson, K. C. (2010). Understanding the link between social and emotional well-being and peer relations in early adolescence: Gender-specific predictors of peer acceptance. *Journal of Youth and Adolescence*, *39*, 1330-1342. doi: 10.1007/s10964-009-9486-9
- Oliver, K. G., Collin, P., Burns, J., & Nicholas, J. (2006). Building resilience in young people through meaningful participation. *Australian e-Journal for the Advancement of Mental Health*, *5*(1), [www.auseinet.com/journal/vol5iss1/oliver.pdf](http://www.auseinet.com/journal/vol5iss1/oliver.pdf).
- Olsson, C. A., Bond, L., Burns, J. M., Vella-Brodrick, D. A., & Sawyer, S. M. (2003). Adolescent resilience: A concept analysis. *Journal of Adolescence*, *26*, 1-11.
- Organisation for Economic Co-operation and Development (OECD). (2009). *Education at a glance: OECD indicators*. Paris, France: Secretary-General of the OECD.
- Raykov, T., & Marcoulides, G. A. (2006). *A first course in Structural Equation Modelling (2nd edition)*. New York: Psychology Press.
- Rees, G., Goswami, H., & Bradshaw, J. (2010). *Developing an index of children's subjective wellbeing in England*. London: The Children's Society.
- Rigby, K., & Slee, P. T. (1991). Bullying among Australian school children: Reported behaviour and attitudes towards victims. *The Journal of Social Psychology*, *131*, 615-627.

- Roeser, R. W., Eccles, J. S., & Strobel, K. (1998). Linking the study of schooling and mental health: Selected issues and empirical illustrations at the level of the individual. *Educational Psychologist, 33*, 153-176.
- Rubin, K. H., Bukowski, W., & Parker, J. (2006). Peer interactions, relationships, and groups. In N. Eisenberg (Ed.), *Handbook of child psychology: Social, emotional and personality development (6th Ed)* (pp. 571-645). New York: Wiley.
- Sanson, A., Misson, S., Wake, M., Zubrick, S. R., Silburn, S., Rothman, S., . . . Dickenson, J. (2005). LSAC Technical Paper #2. Summarising children's wellbeing: the LSAC Outcome Index. Melbourne, Victoria: Australian Institute of Family Studies.
- Scalas, L. F., & Marsh, H. W. (2011). Relations between specific and global domains of self-concept: A substantive methodological synergy. Oxford: SELF Research Centre, University of Oxford.  
<http://www.education.ox.ac.uk/wordpress/wp-content/uploads/2011/05/Polycymaker-Summary.pdf>.
- Schafer, J. L. (1999). Multiple imputation: A primer. *Statistical Methods in Medical Research, 8*, 3-15. doi: 10.1177/096228029900800102
- Seligman, M. E. P., & Csikszentimihalyi, M. (2000). Positive psychology: An introduction. *American Psychologist, 55*, 5-14.
- Shanafelt, T. D., West, C., Zhao, X., Novotny, P., Kolars, J., Habermann, T., & Sloan, J. (2005). Relationship between increased personal well-being and enhanced empathy among internal medicine residents. *Journal of General Internal Medicine, 20*, 559-564. doi: 10.1111/j.1525-1497.2005.0108.x
- Silva, A. J., & Caetano, A. (2013). Validation of the Flourishing Scale and Scale of Positive and Negative Experience in Portugal. *Social Indicators Research, 110*, 469-478. doi: 10.1007/s11205-011-9938-y
- Slee, P. T. (2005). Bullying in Australia. In M. Tsuchiya & P. Smith (Eds.), *Eliminating bullying in schools - Japan and the World*. Kyoto, Japan: Minerva Publishing Co.
- Slee, P. T., Lawson, M. J., Russell, A., Askill-Williams, H., Dix, K. L., Owens, L. D., Skrzypiec, G., Spears, B. (2009). KidsMatter evaluation final report. Adelaide, South Australia: Centre for Analysis of Educational Futures, Flinders University of South Australia.
- Slee, P. T., Murray-Harvey, R., Dix, K. L., Skrzypiec, G., Askill-Williams, H., Lawson, M. J., & Krieg, S. (2012) KidsMatter Early Childhood evaluation final report. Adelaide, South Australia: Research Centre for Student Wellbeing and Prevention of Violence, Flinders University.
- Slee, P. T., & Shute, R. (2014). *Theories in developmental psychology (2nd. Edt. In Preparation)*. Oxfordshire: Routledge Psychology Press.



- Sutton, J., Smith, P. K., & Swettenham, J. (1999). Social cognition and bullying: Social inadequacy or skilled manipulation? *British Journal of Developmental Psychology*, *17*, 435-450.
- Tabachnick, B. G., & Fidell, L. S. (2007). *Using multivariate statistics (5th edition)*. Boston, MA: Pearson Education, Inc.
- Tan, L., & Bibby, Y. (2011). Performance comparison between IB school students and non-IB school students on the International Schools' Assessment (ISA) and on the Social and Emotional Wellbeing Questionnaire. Melbourne: Australian Council for Educational Research.
- Teddlie, C., & Yu, F. (2007). Mixed methods sampling: A typology with examples. *Journal of Mixed Methods Research*, *1(1)*, 77-100. doi: 10.1177/2345678906292430
- Tkach, C. T. (2006). *Unlocking the treasury of human kindness: Enduring improvements in mood, happiness, and self-evaluations*. Doctoral dissertation, University of California, Riverside. (Dissertation Abstracts International, 67, 603.)
- Tomyn, A. J., & Cummins, R. A. (2011). The subjective wellbeing of high-school students: Validating the Personal Wellbeing Index-School Children. *Social Indicators Research*, *101*, 405-418.
- Trentacosta, C. J., & Shaw, D. S. (2009). Emotional self-regulation, peer rejection, and antisocial behavior: Development associations from early childhood to early adolescence. *Journal of Applied Developmental Psychology*, *30*, 356-365.
- Tugade, M. M., & Fredrickson, B. L. (2004). Resilient individuals use positive emotions to bounce back from negative emotional experiences. *Journal of Personality and Social Psychology*, *86*, 320-333.
- Ullman, J. B. (2007). Structural Equation Modelling. In B. G. Tabachnick & L. S. Fidell (Eds.), *Using Multivariate Statistics 5th Edition* (pp. 676-780). Boston, MA: Pearson Education Inc.
- Vaishnavia, S., Connor, K., & Davidson, J. R. T. (2007). An abbreviated version of the Connor-Davidson Resilience Scale (CD-RISC), the CD-RISC2: Psychometric properties and applications in psychopharmacological trials. *Psychiatry Research*, *152(2-3)*, 293-297.
- Van der Graaff, J., Branje, S., De Wied, M., Hawk, S., Van Lier, P., & Meeus, W. (2013). Perspective taking and empathic concern in adolescence: Gender differences in developmental changes. *Developmental Psychology*, *Online First Publication, September 16, 2013*. doi: 10.1037/a0034325
- Venning, A., Wilson, A., Kettler, L., & Elliott, J. (2012). Mental health among youth in South Australia: A survey of flourishing, languishing, struggling, and floundering. *Australian Psychologist*, *48*, 299-310. doi: 10.1111/j.1742-9544.2012.00068.x

- Wagnild, G. M., & Young, H. M. (1993). Development and psychometric evaluation of the resilience scale. *Journal of Nursing Measurement, 1*, 165-178.
- Wang, J., & Wang, X. (2012). *Structural Equation Modeling: Applications using MPlus*. Chichester, UK: Higher Education Press.
- Warden, D., & Mackinnon, S. (2003). Prosocial children, bullies and victims: An investigation of their sociometric status, empathy, and social problem-solving strategies. *British Journal of Developmental Psychology, 21*, 367-385.
- Warren, J., Koen, S., & Burrows, L. (2011). Fostering the wellbeing for learning connection. In R. H. Shute, P. T. Slee, R. Murray-Harvey & K. L. Dix (Eds.), *Mental health and well-being*. Adelaide: Shannon Research Press.
- Wei, M., Liao, K. Y., Ku, T., & Shaffer, P. A. (2011). Attachment, self-compassion, empathy, and subjective well-being among college students and community adults. *Journal of Personality, 79*(1), 191-221. doi: 10.1111/j.1467-6494.2010.00677.x
- Wentzel, K. R. (2009). Peers and academic functioning at school. In K. H. Rubin, W. M. Bukowski & B. Laursen (Eds.), *Handbook of peer interactions, relationships, and groups* (pp. 531-547). New York: The Guilford Press.
- World Health Organisation (WHO). (2013a). Mental health: strengthening our response: Fact sheet N°220, from <http://www.who.int/mediacentre/factsheets/fs220/en/index.html>
- World Health Organisation (WHO). (2013b). What is a health promoting school? , from [http://www.who.int/school\\_youth\\_health/gshi/hps/en/index.html](http://www.who.int/school_youth_health/gshi/hps/en/index.html)
- Yu, X., & Zhang, J. (2007). Factor analysis and psychometric evaluation of the Connor-Davidson Resilience Scale (CD RISC) with Chinese people. *Social Behavior and Personality, 35*, 19-30.



# Appendices

## Appendix A

Appendix A Table 1 Flourishing (FloS) items

Flourishing Scale	very strongly disagree		strongly disagree		disagree		neither agree nor disagree		agree		strongly agree		very strongly agree		Subtotal	
	Count	%	Count	%	Count	%	Count	%	Count	%	Count	%	Count	%	Count	%
I lead a purposeful & meaningful life.	56	2.9%	53	2.8%	103	5.4%	411	21.6%	602	31.6%	390	20.5%	290	15.2%	1905	100.0%
My social relationships are supportive and rewarding	31	1.6%	24	1.3%	96	5.0%	309	16.2%	694	36.4%	487	25.5%	266	13.9%	1907	100.0%
I am interested in my daily activities	26	1.4%	40	2.1%	128	6.7%	370	19.4%	673	35.3%	421	22.1%	247	13.0%	1905	100.0%
I contribute to the happiness and well-being of others	23	1.2%	22	1.2%	52	2.7%	303	15.9%	787	41.2%	461	24.1%	261	13.7%	1909	100.0%
I am good at the activities that are important to me	15	0.8%	17	0.9%	67	3.5%	178	9.3%	537	28.1%	557	29.2%	537	28.1%	1908	100.0%
People respect me	26	1.4%	35	1.8%	113	5.9%	411	21.6%	659	34.6%	455	23.9%	208	10.9%	1907	100.0%
I am optimistic about my future	38	2.0%	45	2.4%	105	5.5%	329	17.3%	486	25.5%	461	24.2%	442	23.2%	1906	100.0%
I am a good person living a good life	47	2.5%	35	1.8%	94	4.9%	344	18.0%	517	27.1%	449	23.5%	421	22.1%	1907	100.0%

Appendix A Table 2 Mental Health Continuum (MentHC) items

Mental Health Continuum	never		once or twice		about once a week		2 or 3 times a week		almost every day		everyday		total	
	Count	%	Count	%	Count	%	Count	%	Count	%	Count	%	Count	%
	Happy	27	1.4%	99	5.3%	94	5.0%	309	16.4%	975	51.8%	379	20.1%	1883
Interested in life	47	2.5%	97	5.2%	178	9.5%	380	20.3%	733	39.1%	440	23.5%	1875	100.0%
Satisfied with life	70	3.8%	139	7.5%	184	10.0%	375	20.3%	695	37.6%	383	20.7%	1846	100.0%
That you had something important to contribute to society	144	7.7%	233	12.5%	284	15.2%	469	25.1%	514	27.5%	226	12.1%	1870	100.0%
That you belonged to a community (like a social group, your school, or your neighbourhood)	125	6.7%	160	8.5%	196	10.4%	326	17.3%	594	31.6%	478	25.4%	1879	100.0%
That our society is a good place, or is becoming a better place, for all people	184	9.8%	224	12.0%	235	12.5%	424	22.6%	526	28.1%	281	15.0%	1874	100.0%
That people are basically (generally) good	93	5.0%	187	10.0%	242	12.9%	476	25.4%	637	34.0%	239	12.8%	1874	100.0%
That the way our society works made sense to you	204	10.9%	238	12.7%	261	14.0%	412	22.0%	534	28.6%	220	11.8%	1869	100.0%
That you liked most parts of your personality	106	5.7%	166	8.9%	211	11.3%	384	20.5%	641	34.2%	366	19.5%	1874	100.0%
That you are good at managing the responsibilities of your daily life	63	3.4%	164	8.8%	206	11.0%	416	22.2%	664	35.4%	361	19.3%	1874	100.0%
That you had warm and trusting relationships with others	61	3.3%	125	6.7%	172	9.2%	332	17.7%	686	36.6%	496	26.5%	1872	100.0%
That you had experiences that challenged you to grow and become a better person	68	3.6%	151	8.1%	212	11.3%	425	22.7%	635	33.9%	384	20.5%	1875	100.0%
Confident to think or express your own ideas and opinions	86	4.6%	158	8.4%	250	13.3%	431	23.0%	596	31.8%	356	19.0%	1877	100.0%
That your life has a sense of direction or meaning to it	131	7.0%	178	9.5%	217	11.6%	349	18.6%	542	28.9%	459	24.5%	1876	100.0%

Appendix A Table 3 Stirling Children's Well-being Scale (StirCWB) items

Stirling Children's Well-being	never		not much of the time		some of the time		quite a lot of the time		all of the time	
	Count	%	Count	%	Count	%	Count	%	Count	%
	I think good things will happen in my life.	38	2.0%	165	8.6%	609	31.8%	829	43.2%	277
I have always told the truth.	35	1.8%	183	9.5%	736	38.4%	809	42.2%	154	8.0%
I've been able to make choices easily.	54	2.8%	276	14.4%	727	38.0%	724	37.8%	132	6.9%
I can find lots of fun things to do.	33	1.7%	175	9.1%	506	26.4%	785	40.9%	419	21.8%
I feel that I am good at some things.	50	2.6%	144	7.5%	503	26.3%	777	40.6%	438	22.9%
I think lots of people care about me.	85	4.5%	240	12.6%	585	30.7%	659	34.5%	339	17.8%
I like everyone I have met.	163	8.5%	317	16.5%	751	39.2%	566	29.5%	120	6.3%
I think there are many things I can be proud of.	43	2.3%	228	11.9%	546	28.6%	699	36.6%	393	20.6%
I've been feeling calm.	96	5.0%	321	16.8%	597	31.2%	680	35.5%	219	11.4%
I've been in a good mood.	65	3.4%	273	14.3%	579	30.2%	761	39.7%	237	12.4%
I enjoy what each new day brings.	76	4.0%	282	14.7%	743	38.8%	606	31.7%	207	10.8%
I've been getting on well with people.	27	1.4%	130	6.8%	465	24.3%	964	50.4%	326	17.1%
I always share my lollies/ sweets/ treats.	163	8.5%	215	11.3%	547	28.6%	618	32.3%	368	19.3%
I've been cheerful about things.	51	2.7%	207	10.8%	609	31.8%	770	40.2%	277	14.5%
I've been feeling relaxed.	117	6.1%	375	19.6%	607	31.7%	579	30.2%	237	12.4%

Appendix A Table 4 Empathy items

Empathy	not like me at all		hardly ever like me		occasionally like me		fairly like me		very like me		Subtotal	
	Count	%	Count	%	Count	%	Count	%	Count	%	Count	%
When there is an emergency I feel worried and upset.	130	6.8%	296	15.5%	642	33.7%	521	27.3%	318	16.7%	1907	100.0%
I get very worried and upset when I see someone who needs help in an emergency.	102	5.4%	297	15.6%	598	31.4%	557	29.2%	351	18.4%	1905	100.0%
I want to help people who get treated badly.	35	1.8%	76	4.0%	424	22.3%	733	38.6%	632	33.3%	1900	100.0%
I often get affected by things I see happen.	103	5.4%	331	17.4%	588	30.9%	562	29.6%	317	16.7%	1901	100.0%
I often feel worried about people that are not as lucky as me, and feel sorry for them.	70	3.7%	186	9.8%	517	27.2%	646	33.9%	485	25.5%	1904	100.0%
I am quite a soft-hearted person.	76	4.0%	202	10.6%	521	27.3%	670	35.2%	437	22.9%	1906	100.0%
I sometimes try to understand my friends better by imagining myself in their position.	106	5.6%	246	12.9%	561	29.5%	620	32.6%	369	19.4%	1902	100.0%
I think people can have different opinions about the same thing.	33	1.7%	65	3.4%	286	15.0%	636	33.4%	882	46.4%	1902	100.0%
When people around me are nervous or worried, I get a bit scared and worried too.	205	10.8%	451	23.8%	613	32.3%	429	22.6%	200	10.5%	1898	100.0%
When I am angry or upset at someone, I usually try to imagine what he or she is thinking or feeling.	257	13.5%	467	24.5%	565	29.7%	401	21.1%	213	11.2%	1903	100.0%
Sometimes I feel helpless when people around me are upset.	196	10.3%	401	21.1%	640	33.6%	444	23.3%	223	11.7%	1904	100.0%
When I am arguing with my friends about what we are going to do, I think carefully about what they are saying before I decide whose idea is best.	100	5.3%	249	13.1%	634	33.3%	655	34.4%	265	13.9%	1903	100.0%

Appendix A Table 5 Global Self-concept items

Global Self-concept	never		rarely		sometimes		most of the time		always		Subtotal	
	Count	%	Count	%	Count	%	Count	%	Count	%	Count	%
I have a lot to be proud of.	46	2.4%	210	10.9%	608	31.6%	760	39.5%	298	15.5%	1922	100.0%
I can do things as well as most people.	61	3.2%	207	10.8%	515	26.8%	856	44.6%	280	14.6%	1919	100.0%
I'm as good as most other people.	76	4.0%	246	12.9%	529	27.7%	732	38.3%	329	17.2%	1912	100.0%
Other people think I am a good person.	41	2.1%	119	6.2%	437	22.9%	925	48.4%	388	20.3%	1910	100.0%
When I do something, I do it well.	34	1.8%	153	8.0%	579	30.2%	854	44.5%	299	15.6%	1919	100.0%
A lot of things about me are good.	59	3.1%	173	9.1%	505	26.5%	847	44.4%	322	16.9%	1906	100.0%

Appendix A Table 6 Self-Reflection items

Self-Reflection	very strongly disagree		strongly disagree		disagree		agree		strongly agree		very strongly agree		Total	
	Count	%	Count	%	Count	%	Count	%	Count	%	Count	%	Count	%
I often think about my thoughts.	40	2.1%	39	2.0%	204	10.6%	736	38.4%	473	24.7%	425	22.2%	1917	100.0%
I often spend time in self-reflection.	72	3.8%	112	5.8%	545	28.4%	681	35.5%	316	16.5%	191	10.0%	1917	100.0%
I frequently examine (think about) my feelings.	59	3.1%	97	5.1%	422	22.1%	713	37.3%	360	18.8%	260	13.6%	1911	100.0%
I really think about why I behave in the way that I do.	49	2.6%	74	3.9%	404	21.1%	729	38.0%	412	21.5%	250	13.0%	1918	100.0%
I frequently take time to reflect on (think about) my thoughts.	75	3.9%	100	5.2%	515	26.9%	691	36.1%	313	16.4%	220	11.5%	1914	100.0%
I often think about the way I feel about things.	57	3.0%	80	4.2%	325	17.0%	738	38.6%	395	20.7%	317	16.6%	1912	100.0%



Appendix A Table 7 Resilience items

Resilience (not for publication)	not true at all		rarely true		sometimes true		often true		true nearly all the time		Subtotal	
	Count	%	Count	%	Count	%	Count	%	Count	%	Count	%
I am able to adapt (adjust) when changes occur.	38	2.0%	111	5.9%	575	30.4%	881	46.5%	289	15.3%	1894	100.0%
I can deal with whatever comes my way.	38	2.0%	153	8.1%	646	34.1%	804	42.4%	255	13.4%	1896	100.0%
I try to see the humorous (funny) side of things when I am faced with problems.	65	3.4%	180	9.5%	507	26.8%	666	35.2%	473	25.0%	1891	100.0%
Having to cope with stress can make me stronger.	157	8.3%	330	17.4%	622	32.9%	536	28.3%	247	13.1%	1892	100.0%
I tend to bounce back after illness, injury, or other hardships.	51	2.7%	144	7.6%	516	27.3%	684	36.2%	495	26.2%	1890	100.0%
I believe I can achieve my goals, even if there are obstacles.	46	2.4%	140	7.4%	488	25.8%	694	36.7%	523	27.7%	1891	100.0%
Under pressure, I stay focused and think clearly.	107	5.7%	291	15.4%	671	35.4%	584	30.9%	240	12.7%	1893	100.0%
I am not easily discouraged by failure.	107	5.7%	280	14.8%	660	35.0%	576	30.5%	265	14.0%	1888	100.0%
I think of myself as a strong person when dealing with life's challenges and difficulties.	82	4.3%	203	10.7%	624	33.0%	648	34.3%	334	17.7%	1891	100.0%
I am able to handle unpleasant or painful feelings like sadness, fear, and anger.	117	6.2%	259	13.7%	581	30.7%	622	32.9%	313	16.5%	1892	100.0%

Appendix A Table 8 Relationship items

Relationship	very strongly disagree		strongly disagree		disagree		agree		strongly agree		very strongly agree		Subtotal	
	Count	%	Count	%	Count	%	Count	%	Count	%	Count	%	Count	%
	I get along with other students.	25	1.3%	30	1.6%	97	5.0%	665	34.6%	626	32.6%	479	24.9%	1922
At school I participate with anyone or any group.	55	2.9%	79	4.1%	428	22.3%	743	38.7%	391	20.4%	225	11.7%	1921	100.0%
I have a sense of togetherness with the other students in my class.	48	2.5%	76	4.0%	305	15.9%	820	42.7%	445	23.2%	227	11.8%	1921	100.0%
At school I feel that I really belong.	84	4.4%	95	4.9%	364	19.0%	790	41.1%	382	19.9%	205	10.7%	1920	100.0%
My teachers always find time to talk to students	42	2.2%	65	3.4%	328	17.1%	759	39.7%	461	24.1%	259	13.5%	1914	100.0%
			never		once in a while		pretty often		very often		Subtotal			
			Count	%	Count	%	Count	%	Count	%	Count	%	Count	%
I like to help people who are being harassed.			112	5.9%	579	30.3%	760	39.8%	457	24.0%	1908		100.0%	
I enjoy helping others.			80	4.2%	236	12.4%	815	42.7%	777	40.7%	1908		100.0%	
			Not like me at all		Hardly ever like me		Occasionally like me		Fairly like me		Very like me		Subtotal	
			Count	%	Count	%	Count	%	Count	%	Count	%	Count	%
I want to help people who get treated badly.			35	1.8%	76	4.0%	424	22.3%	733	38.6%	632	33.3%	1900	100.0%
I sometimes try to understand my friends better by imagining myself in their position.			106	5.6%	246	12.9%	561	29.5%	620	32.6%	369	19.4%	1902	100.0%
			not true		somewhat true		certainly true		Subtotal					
			Count	%	Count	%	Count	%	Count	%	Count	%	Count	%
I try to be nice to people. I care about their feelings.			56	3.0%	620	32.7%	1219	64.3%	1895		100.0%			
I am helpful if someone is hurt, upset or feeling ill.			94	5.0%	943	49.9%	851	45.1%	1888		100.0%			
I have one good friend or more.			52	2.8%	292	15.5%	1540	81.7%	1884		100.0%			
Other people my age generally like me.			148	7.8%	1044	55.3%	696	36.9%	1888		100.0%			
I often volunteer to help others (parents, teachers, children).			324	17.2%	1089	57.7%	473	25.1%	1886		100.0%			

Appendix A Table 9 School Satisfaction items

School Satisfaction	very strongly disagree		strongly disagree		disagree		agree		strongly agree		very strongly agree		Total	
	Count	%	Count	%	Count	%	Count	%	Count	%	Count	%	Count	%
My school is a place where I feel happy	41	2.1%	57	3.0%	261	13.6%	980	51.0%	428	22.3%	154	8.0%	1921	100.0%
My school is a place where I really like to go to each day.	93	4.8%	138	7.2%	573	29.8%	821	42.7%	223	11.6%	74	3.9%	1922	100.0%
My school is a place where I find that learning is a lot of fun.	80	4.2%	116	6.1%	560	29.2%	890	46.5%	213	11.1%	57	3.0%	1916	100.0%
My school is a place where I feel safe and secure.	37	1.9%	51	2.7%	198	10.3%	762	39.7%	550	28.7%	321	16.7%	1919	100.0%
My school is a place where I like learning.	64	3.3%	79	4.1%	358	18.7%	940	49.1%	340	17.7%	135	7.0%	1916	100.0%
My school is a place where I get enjoyment from being there.	63	3.3%	82	4.3%	375	19.6%	893	46.7%	359	18.8%	141	7.4%	1913	100.0%
My school is a place where the work we do is interesting.	68	3.6%	88	4.6%	420	22.0%	929	48.6%	325	17.0%	81	4.2%	1911	100.0%
My school is a place where I like to ask questions in class.	72	3.8%	110	5.8%	466	24.4%	841	44.0%	282	14.7%	142	7.4%	1913	100.0%
My school is a place where I always try to do my best.	21	1.1%	37	1.9%	213	11.2%	662	34.7%	519	27.2%	456	23.9%	1908	100.0%
My school is a place where I get excited about the work we do.	131	6.8%	172	9.0%	700	36.6%	698	36.5%	173	9.0%	40	2.1%	1914	100.0%
My school does whatever it can to help students.	39	2.0%	65	3.4%	244	12.7%	739	38.6%	471	24.6%	356	18.6%	1914	100.0%
My teachers always find time to talk to students	42	2.2%	65	3.4%	328	17.1%	759	39.7%	461	24.1%	259	13.5%	1914	100.0%
If I have a problem there is an adult at my school that will help me.	19	1.00%	30	1.60%	176	9.2%	881	45.9%	464	24.2%	351	18.3%	1921	100.0%
I feel supported by my school in the things I do.	29	1.50%	51	2.70%	306	15.9%	877	45.7%	450	23.4%	207	10.8%	1920	100.0%
My school makes me feel that I will be a success.	41	2.10%	58	3.00%	325	16.9%	787	41.0%	464	24.2%	244	12.7%	1919	100.0%
I feel proud of belonging to my school.	42	2.20%	48	2.50%	297	15.5%	788	41.1%	391	20.4%	351	18.3%	1917	100.0%
I get along with other students.	25	1.30%	30	1.60%	97	5.00%	665	34.6%	626	32.6%	479	24.9%	1922	100.0%
At school I participate with anyone or any group.	55	2.90%	79	4.10%	428	22.3%	743	38.7%	391	20.4%	225	11.7%	1921	100.0%
I have a sense of togetherness with the other students in my class.	48	2.50%	76	4.00%	305	15.9%	820	42.7%	445	23.2%	227	11.8%	1921	100.0%
At school I feel that I really belong.	84	4.40%	95	4.90%	364	19.0%	790	41.1%	382	19.9%	205	10.7%	1920	100.0%

Appendix A Table 10 Peer Relations Questionnaire items

Bullying	never		once in a while		pretty often		very often		Subtotal	
	Count	%	Count	%	Count	%	Count	%	Count	%
I get called names by others.	498	26.1%	1033	54.1%	266	13.9%	112	5.9%	1909	100.0%
I like to make friends.	34	1.8%	306	16.0%	814	42.7%	753	39.5%	1907	100.0%
I get picked on by others.	761	39.9%	910	47.8%	163	8.6%	71	3.7%	1905	100.0%
I tell false stories or spread rumours about others.	1499	78.6%	350	18.3%	35	1.8%	24	1.3%	1908	100.0%
I am part of a group that goes round teasing others.	1556	81.5%	270	14.1%	55	2.9%	28	1.5%	1909	100.0%
I like to help people who are being harassed.	112	5.9%	579	30.3%	760	39.8%	457	24.0%	1908	100.0%
I leave others out.	1118	58.8%	701	36.9%	59	3.1%	24	1.3%	1902	100.0%
I like to make others scared of me.	1441	75.6%	346	18.2%	73	3.8%	46	2.4%	1906	100.0%
I share things with others.	110	5.8%	394	20.7%	957	50.2%	446	23.4%	1907	100.0%
I enjoy upsetting wimps.	1681	88.4%	156	8.2%	31	1.6%	34	1.8%	1902	100.0%
I like to get into a fight with someone I can easily beat.	1642	86.1%	170	8.9%	51	2.7%	45	2.4%	1908	100.0%
Others make fun of me.	808	42.3%	864	45.3%	170	8.9%	67	3.5%	1909	100.0%
Others leave me out.	763	40.0%	874	45.8%	198	10.4%	73	3.8%	1908	100.0%
I get hit and pushed around by others.	1415	74.2%	389	20.4%	74	3.9%	29	1.5%	1907	100.0%
Others tell false stories or spread rumours about me.	1003	52.6%	648	34.0%	165	8.7%	91	4.8%	1907	100.0%
I enjoy helping others.	80	4.2%	236	12.4%	815	42.7%	777	40.7%	1908	100.0%

Appendix A Table 11 Strengths and Difficulties Questionnaire items

Strengths and Difficulties Questionnaire	Not true		Somewhat true		Certainly true		Subtotal	
	Count	%	Count	%	Count	%	Count	%
I try to be nice to people. I care about their feelings.	56	3.0%	620	32.7%	1219	64.3%	1895	100.0%
I am restless, I cannot stay still for long.	315	16.6%	951	50.2%	627	33.1%	1893	100.0%
I get a lot of headaches, stomach aches or sickness.	830	44.1%	697	37.0%	356	18.9%	1883	100.0%
I usually share with others, for example CD's, games, food.	159	8.4%	944	49.9%	788	41.7%	1891	100.0%
I get very angry and often lose my temper.	830	43.9%	794	42.0%	267	14.1%	1891	100.0%
I would rather be alone than with people of my age.	1037	54.9%	627	33.2%	226	12.0%	1890	100.0%
I usually do as I am told.	131	6.9%	1091	57.7%	670	35.4%	1892	100.0%
I worry a lot.	561	29.7%	772	40.8%	557	29.5%	1890	100.0%
I am helpful if someone is hurt, upset or feeling ill.	94	5.0%	943	49.9%	851	45.1%	1888	100.0%
I am constantly fidgeting or squirming.	631	33.5%	831	44.2%	419	22.3%	1881	100.0%
I have one good friend or more.	52	2.8%	292	15.5%	1540	81.7%	1884	100.0%
I fight a lot. I can make other people do what I want.	1384	73.5%	415	22.0%	85	4.5%	1884	100.0%
I am often unhappy, depressed or tearful.	1042	55.2%	603	31.9%	243	12.9%	1888	100.0%
Other people my age generally like me.	148	7.8%	1044	55.3%	696	36.9%	1888	100.0%
I am easily distracted, I find it difficult to concentrate.	462	24.5%	961	51.0%	461	24.5%	1884	100.0%
I am nervous in new situations. I easily lose confidence.	545	28.9%	880	46.7%	459	24.4%	1884	100.0%
I am kind to younger children.	88	4.7%	526	27.9%	1269	67.4%	1883	100.0%
I am often accused of lying or cheating.	1100	58.5%	561	29.9%	218	11.6%	1879	100.0%
Other children or young people pick on me or bully me.	1449	77.0%	346	18.4%	87	4.6%	1882	100.0%
I often volunteer to help others (parents, teachers, children).	324	17.2%	1089	57.7%	473	25.1%	1886	100.0%
I think before I do things.	201	10.7%	1160	61.5%	526	27.9%	1887	100.0%
I take things that are not mine from home, school or elsewhere.	1470	78.0%	349	18.5%	65	3.5%	1884	100.0%
I get along better with adults than with people my own age.	856	45.5%	773	41.1%	252	13.4%	1881	100.0%
I have many fears, I am easily scared.	926	49.1%	678	35.9%	282	15.0%	1886	100.0%
I finish the work I'm doing. My attention is good.	226	12.0%	1174	62.3%	485	25.7%	1885	100.0%

## Appendix B

### Flourishing Scale (FloS)

Where there were only one or two missing responses in a case, they were replaced with a value of “4” (neither agree nor disagree). The overall number of missing values on the eight items was low (ranged from n=21 (1.1%) to n = 25 (1.3%)).

The full 8-item scale showed an acceptable fit with our data ( $\chi^2(20) = 134.7$ ,  $P < .000$ , RMSEA = .055, 90% C.I. = 0.047-0.065, probability RMSEA  $\leq .05 = 14.5\%$ , CFI =0.974, TLI = 0.963, SRMR = 0.024; Coeff H = 0.92). However, dropping item 10d (*I contribute to the happiness and well-being of others*), which was very skewed (only 5% of students disagreed) provided a model which fit our data very well (see Appendix B Figure 1).

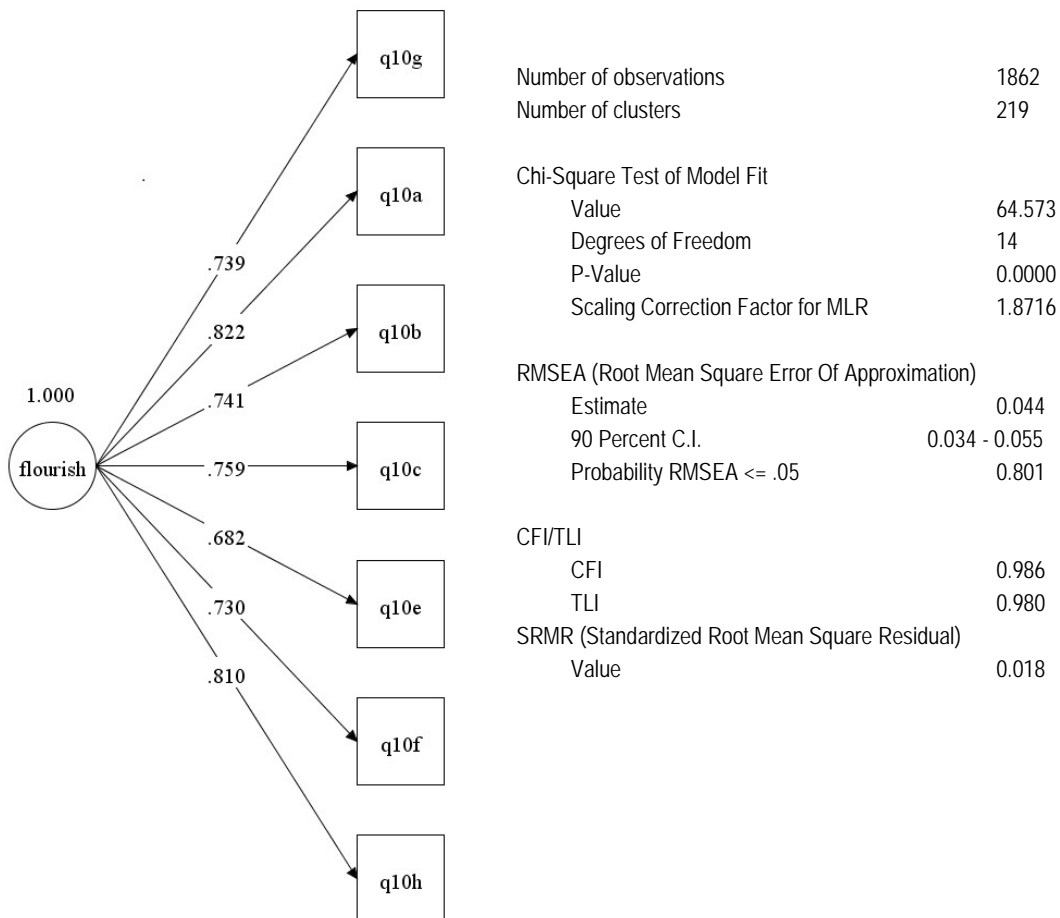

Appendix B Figure 1 Flourish (FloS) latent variable

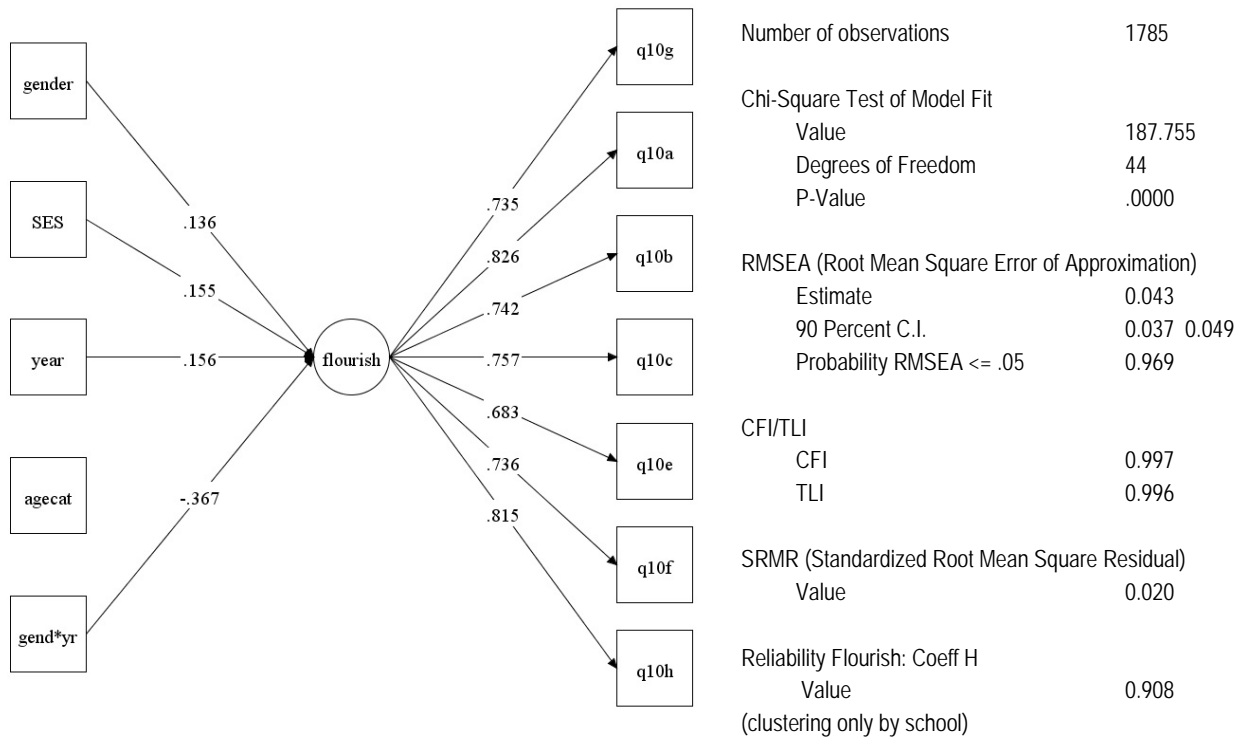

Note: There is a significant interaction between gender and year level so that females in higher years have lower well-being scores. (With a significant interaction, the main effect needs to be interpreted with the interaction. The main effect alone should not be interpreted when there is a significant interaction. Methuén, 2004 <http://www.statmodel.com/discussion/messages/11/499.html>).

Appendix B Figure 2 Influence of covariates on flourishing (FloS) scores (MIMIC model)

## Mental Health Continuum (MentHC)

Keyes's (2006) MentHC did not fit our data well until four items were dropped (two from psychological well-being factor: "That you had something important to contribute to society" and "That you belonged to a community (like a social group, your school, or your neighbourhood)" and two from the social well-being factor: "That you liked most parts of your personality" and "That your life has a sense of direction or meaning to it". These were items that students could have been confused about in their adolescent stage of life. The final MHC model (below) was the model used in other MPlus analyses.

To satisfactorily fit the MentHC model to our data, four items were dropped from the scale. This suggests that the MentHC Scale, originally developed for adults, requires adjustment in order to better suit young people. Further research is required to better formulate social, emotional and psychological items for a MentHC Scale so that it is more appropriate for young people.

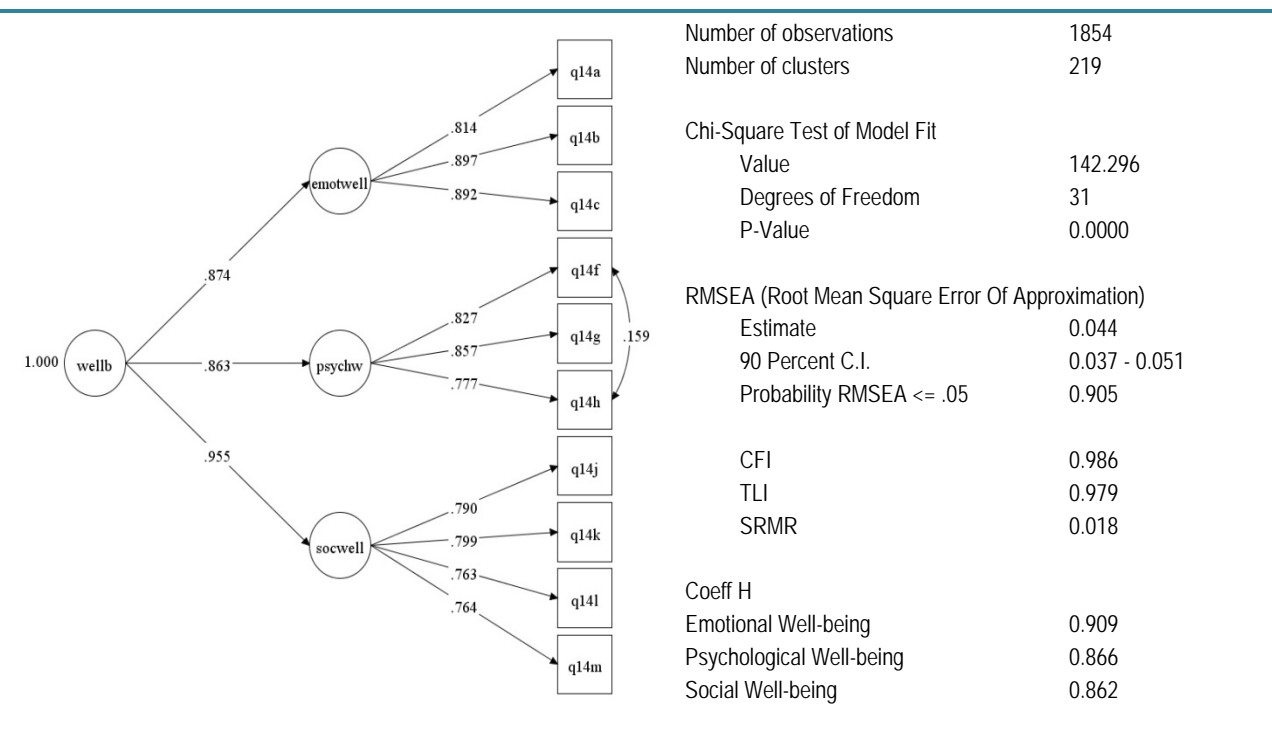

Appendix B Figure 3 MentHC model



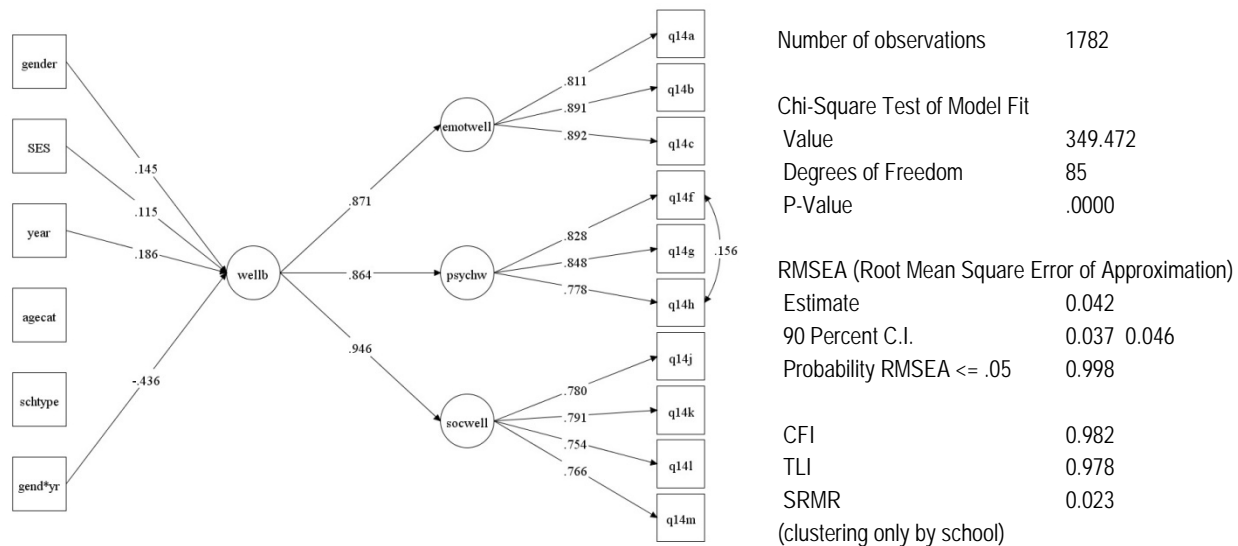

Note: There is a significant interaction between gender and year level so that females in higher years have lower well-being scores. (With a significant interaction, the main effect needs to be interpreted with the interaction. The main effect alone should not be interpreted when there is a significant interaction. Methuén, 2004 <http://www.statmodel.com/discussion/messages/11/499.html>).

Appendix B Figure 4 Influence of covariates on well-being measured using the MentHC (MIMIC model)

## Stirling Children’s Well-being Scale (StirCWB)

There was little missing data amongst the 12 items that comprised the StirC Well-being Scale (for each variable the number of missing values ranged from n=12 to n= 22). Overall there were 59 (3.1%) cases with at least one missing variable. Missing data was not manually replaced so incomplete responses could not be summed to produce a total StirC Well-being (StirCWB) score.

The StirCWB model that fit our data best involved dropping two items which indicated a possible measure of a sub-factor, so only one of the items was needed. The dropped items were: “*I’ve been feeling calm*”, which strongly correlated with the feeling relaxed item, suggesting a sub-factor; and the item “*good at some things*”, which strongly correlated with “*there are many things can be proud of*”, and also suggested a sub-factor.

(Note that a second order well-being latent variable could not be tested as there were only two first order latent variable indicators.)

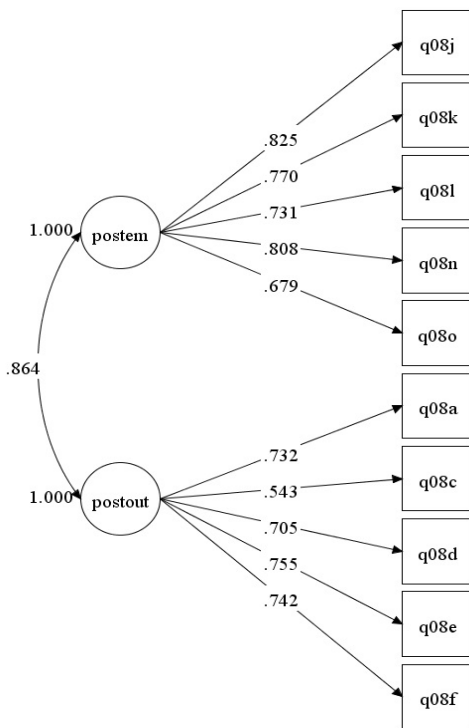

Number of observations	1866
Chi-Square Test of Model Fit	
Value	171.965
Degrees of Freedom	34
P-Value	0.0000
RMSEA (Root Mean Square Error Of Approximation)	
Estimate	0.047
90 Percent C.I.	0.040 0.054
Probability RMSEA <= .05	0.778
CFI/TLI	
CFI	0.981
TLI	0.975
SRMR (Standardized Root Mean Square Residual)	
Value	0.025
Reliability: Coeff H	
Positive Emotional State Value	0.882
Positive Outlook Value	0.836

Appendix B Figure 5      StirCWB model

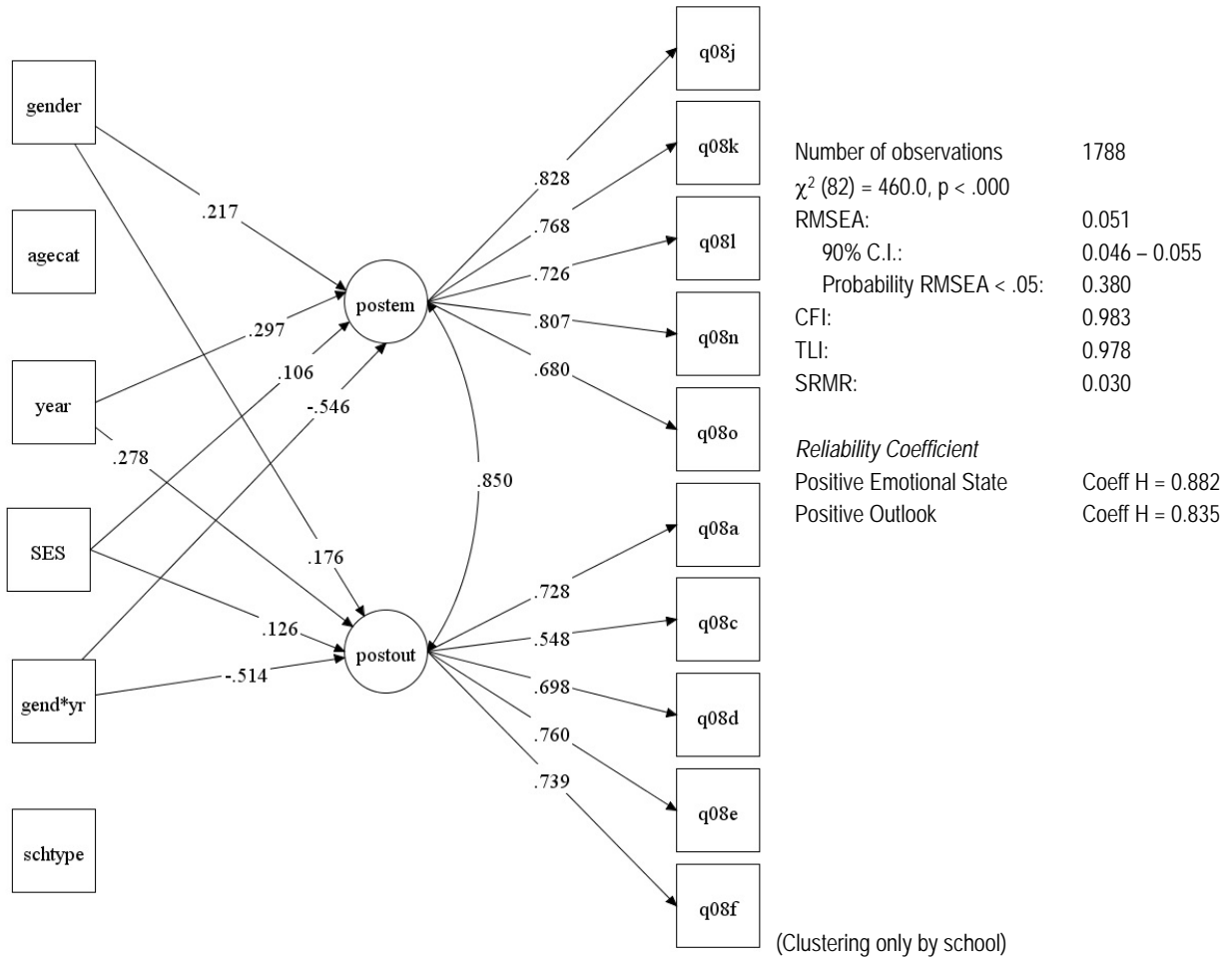

Note: There is a significant interaction between gender and year level so that females in higher years have lower well-being scores. (With a significant interaction, the main effect needs to be interpreted with the interaction. The main effect alone should not be interpreted when there is a significant interaction. Methuen, 2004 <http://www.statmodel.com/discussion/messages/11/499.html>).

Appendix B Figure 6 Influence of covariates on well-being measured using the StirCWB (MIMIC model)

## Cognitive and Affective Empathy

A confirmatory factor analysis found that after trimming (following guidelines by Kline, 2011) the Empathy Scale model was a good fit with the data. Through this process the model became more parsimonious and the number of items was reduced to seven. In the original scale the correlation between cognitive and affective empathy was high (.9) which suggested that the factors were measuring the same thing. After trimming the correlation between the two factors was reduced, implying that they were measuring two different aspects of empathy. Factor Score coefficients of the 7-items were used to calculate cognitive and affective empathy scores.

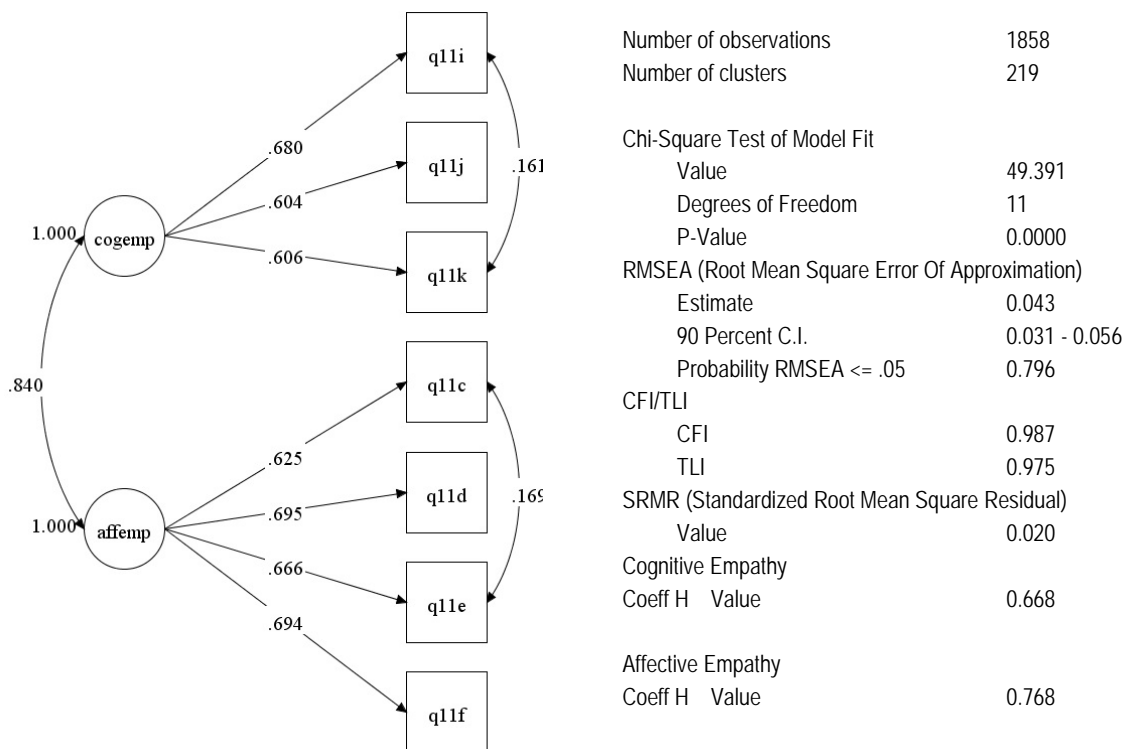

Appendix B Figure 7 Cognitive and Affective Empathy Model

## Global Self-Concept

Marsh's (1990) global self-concept factor comprising six items did not fit our data well until one item "I can do things as well as most people" was dropped because it correlated strongly with another item in the factor "I'm as good as most people" (suggesting a sub-factor). The final 5-item factor fit our data well.

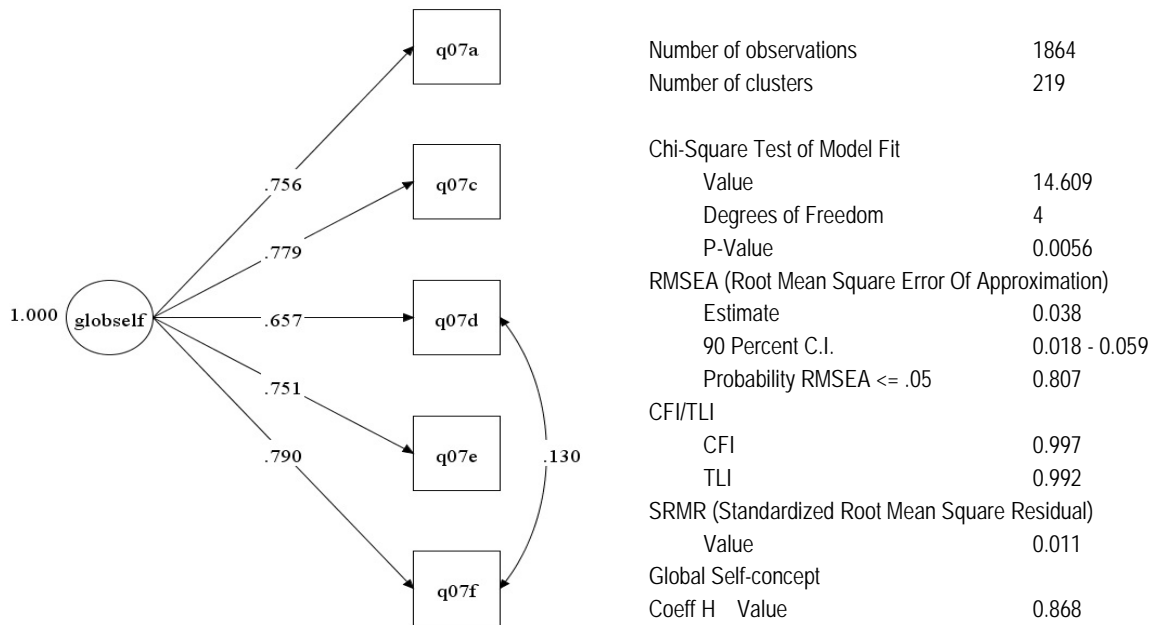

Appendix B Figure 8 Global Self-concept latent variable

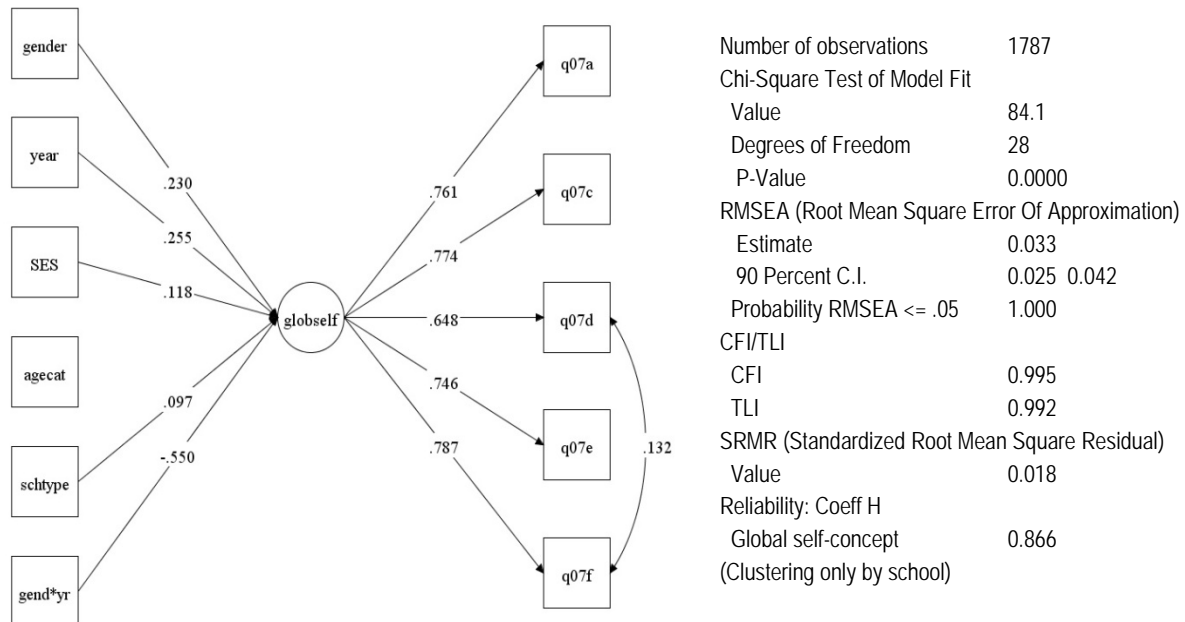

Appendix B Figure 9 Influence of covariates on global self-concept (MIMIC model)

## Self-Reflection

No items were dropped from the self-reflection construct as the model fit our data well and the self-reflection factor showed good reliability (Coeff H = 0.9).

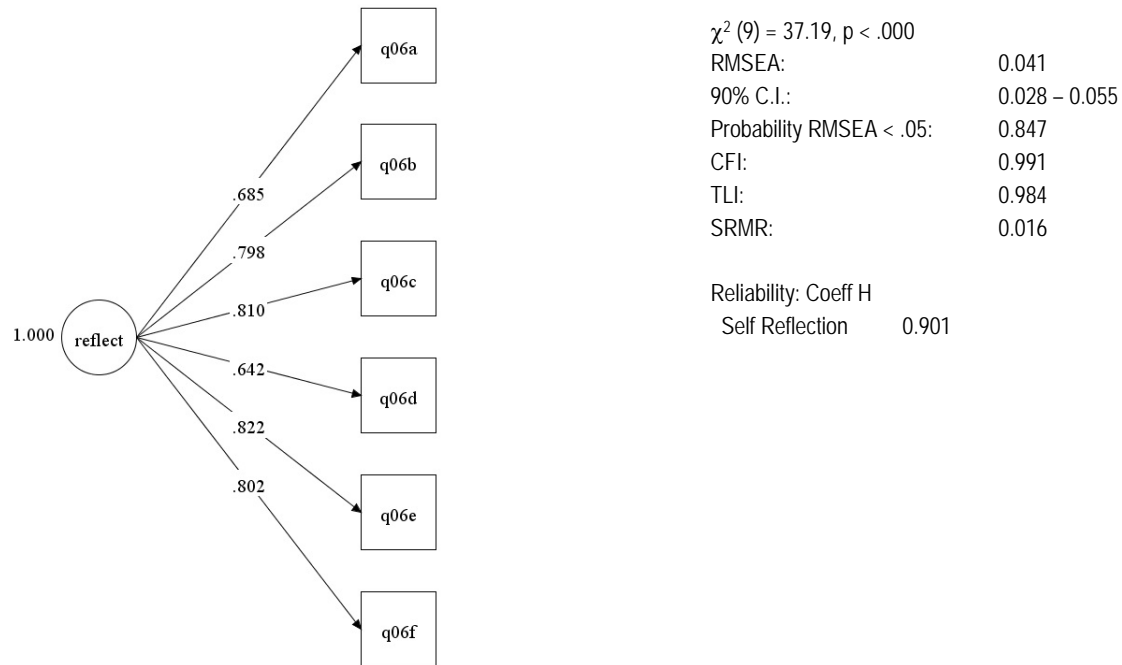

Appendix B Figure 10 Self-reflection latent variable

## Resilience

One item “*I can deal with whatever comes my way*” was dropped from the Resilience scale as it strongly correlated with the item “*I am able to adapt (adjust) when changes occur*”. The correlation suggested a sub-factor of adaptation, so only one of these items was required in the model. The final model fit our data well.

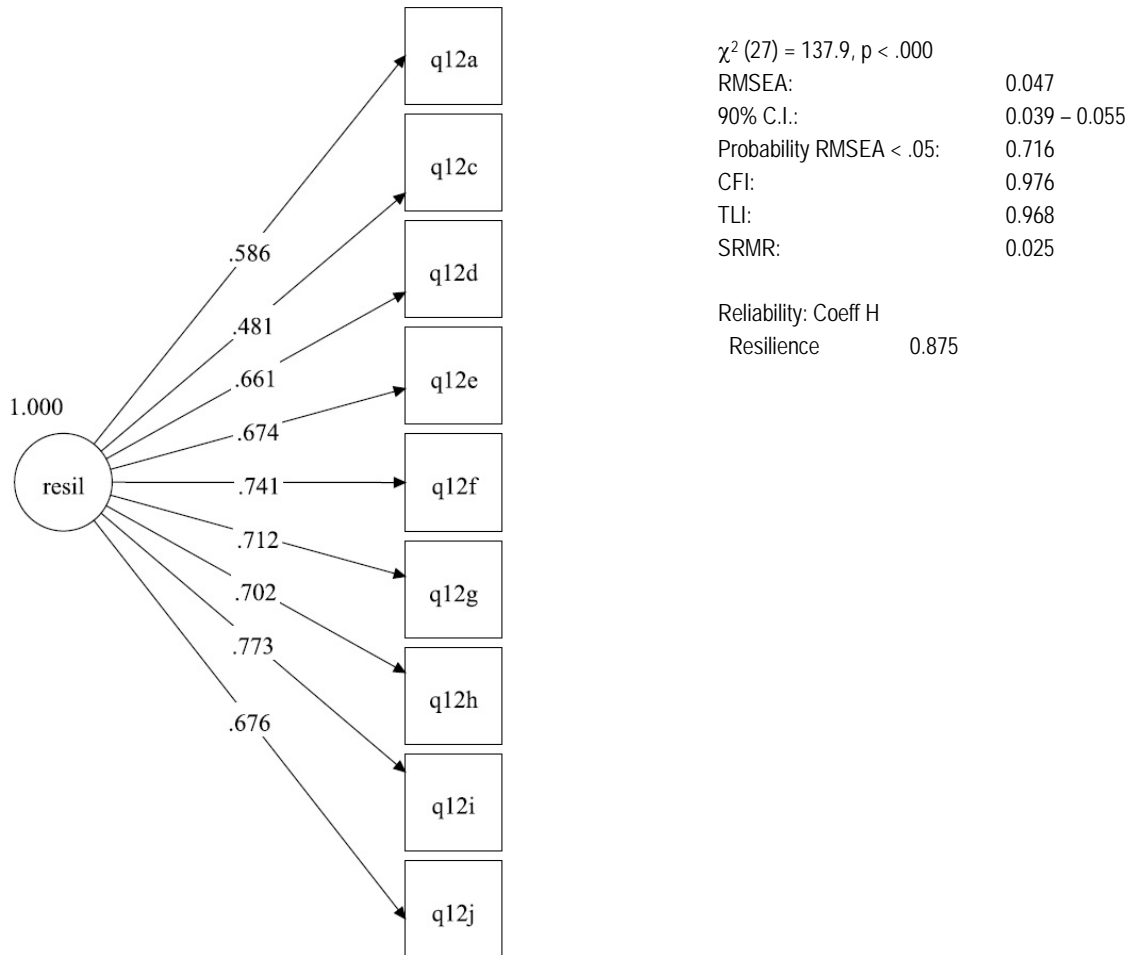

Appendix B Figure 11 Resilience latent variable

## Relationships

Items that were included in an EFA to examine the relationships construct included all the items shown in Appendix A Table 8. After some trimming the final CFA of the factors was found to be a good fit with our data.

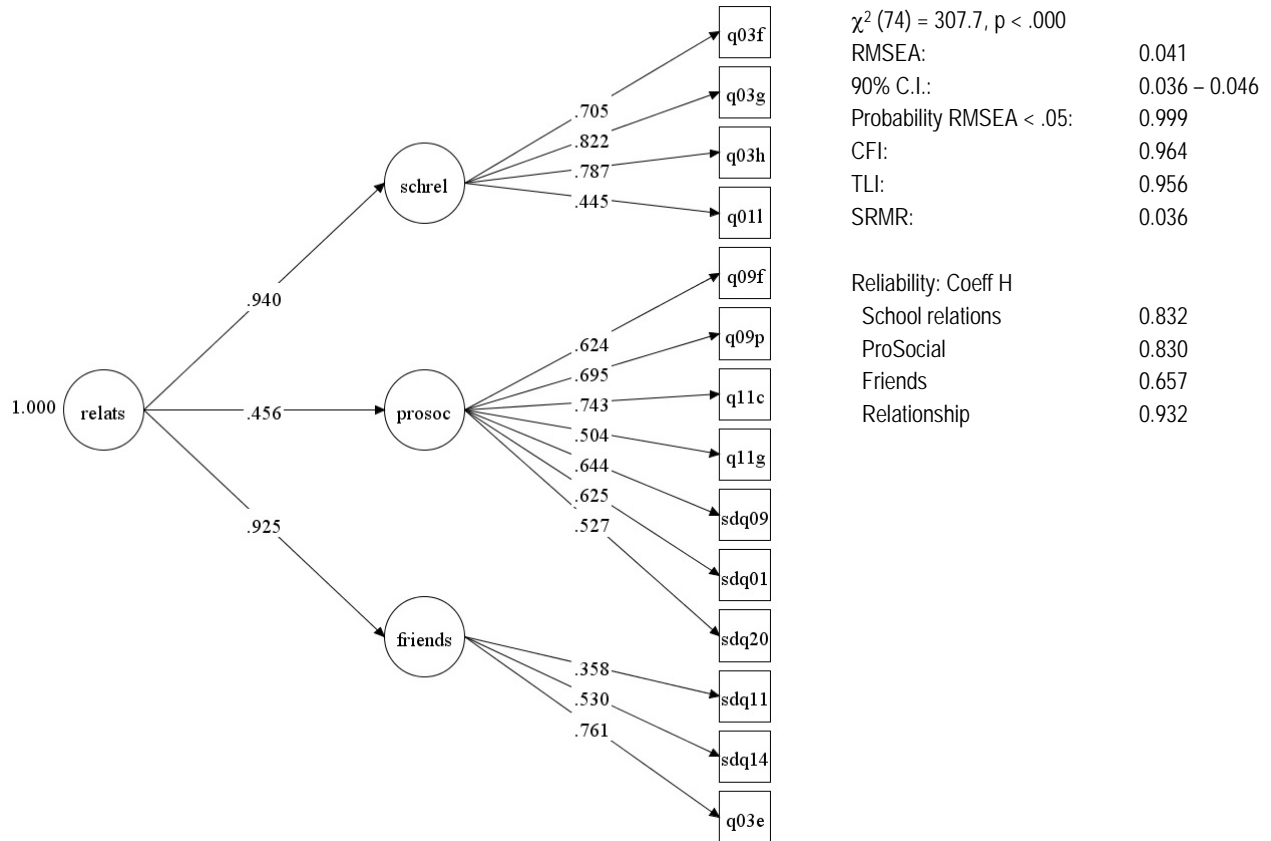

Appendix B Figure 12 Relationships latent variable



## School Satisfaction

An EFA found that a four factor structure fit our data best ( $\chi^2 (116) = 496.2, p < .000$ ; RMSEA: 0.042; 90% C.I.: 0.038 – 0.046; Probability RMSEA < .05: 1.000; CFI: 0.979; TLI: 0.965; SRMR: 0.016). A CFA investigating this structure further found that the model fit our data best if item “*At school I feel that I really belong*” was dropped because it cross-loaded on other factors and the errors of some items were correlated. Correlated items included “*My school does whatever it can to help students*” and “*My teachers always find time to talk to students*”, which incorporate a separate construct of teachers helping; and “*If I have a problem there is an adult at my school that will help me*” and “*I feel supported by my school in the things I do*” which measures a particular aspect of how the school supports students. A correlation between enjoying school and enjoying learning was also significant and added to the model. The final model is shown below shows good construct validity and all sub-factors, as well as school satisfaction, show good reliability.

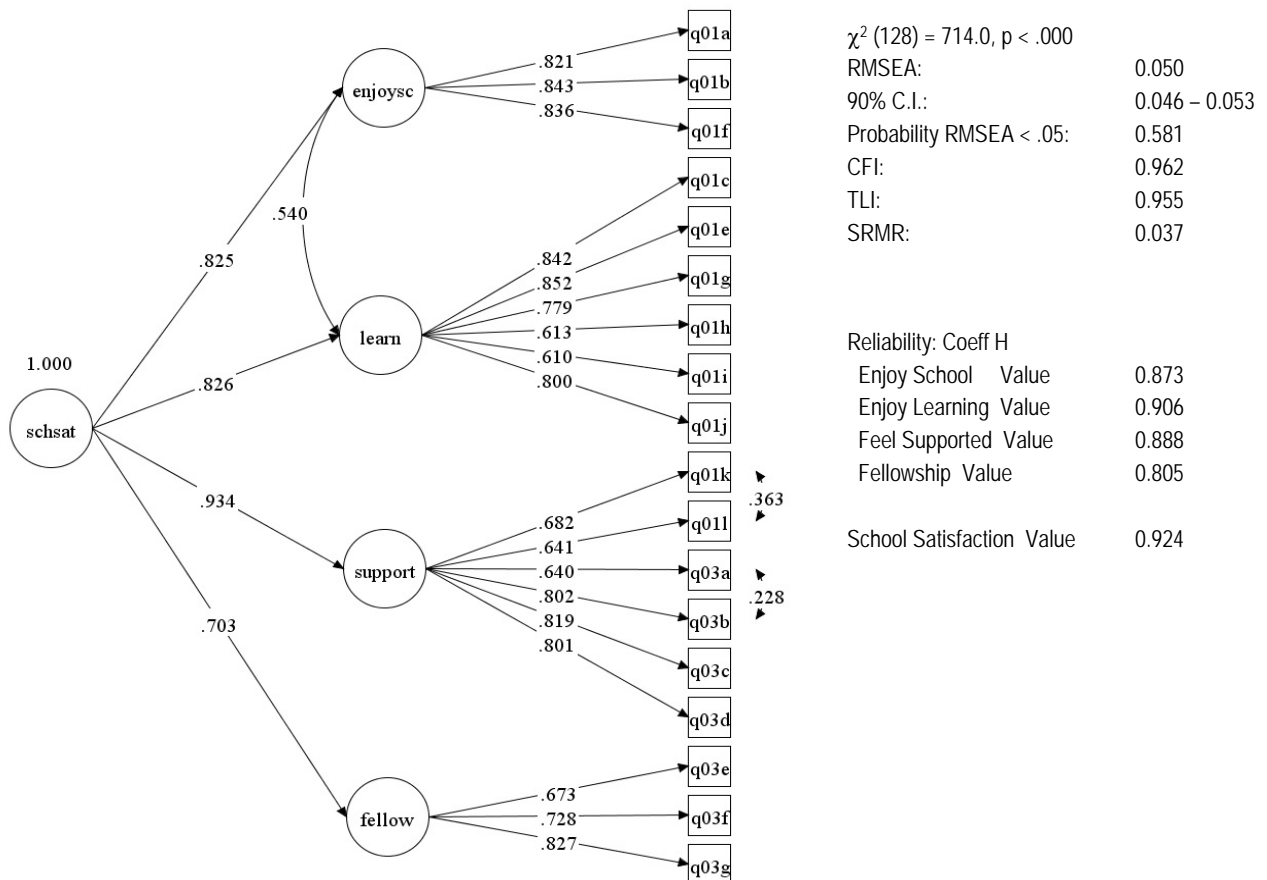

Appendix B Figure 13 School satisfaction model

# Strengths and Difficulties Questionnaire

A CFA in Mplus treating all SDQ items as censored from below found that each of the subscales had adequate reliability except the peer problems subscale which had a Coefficient H Value of .644.

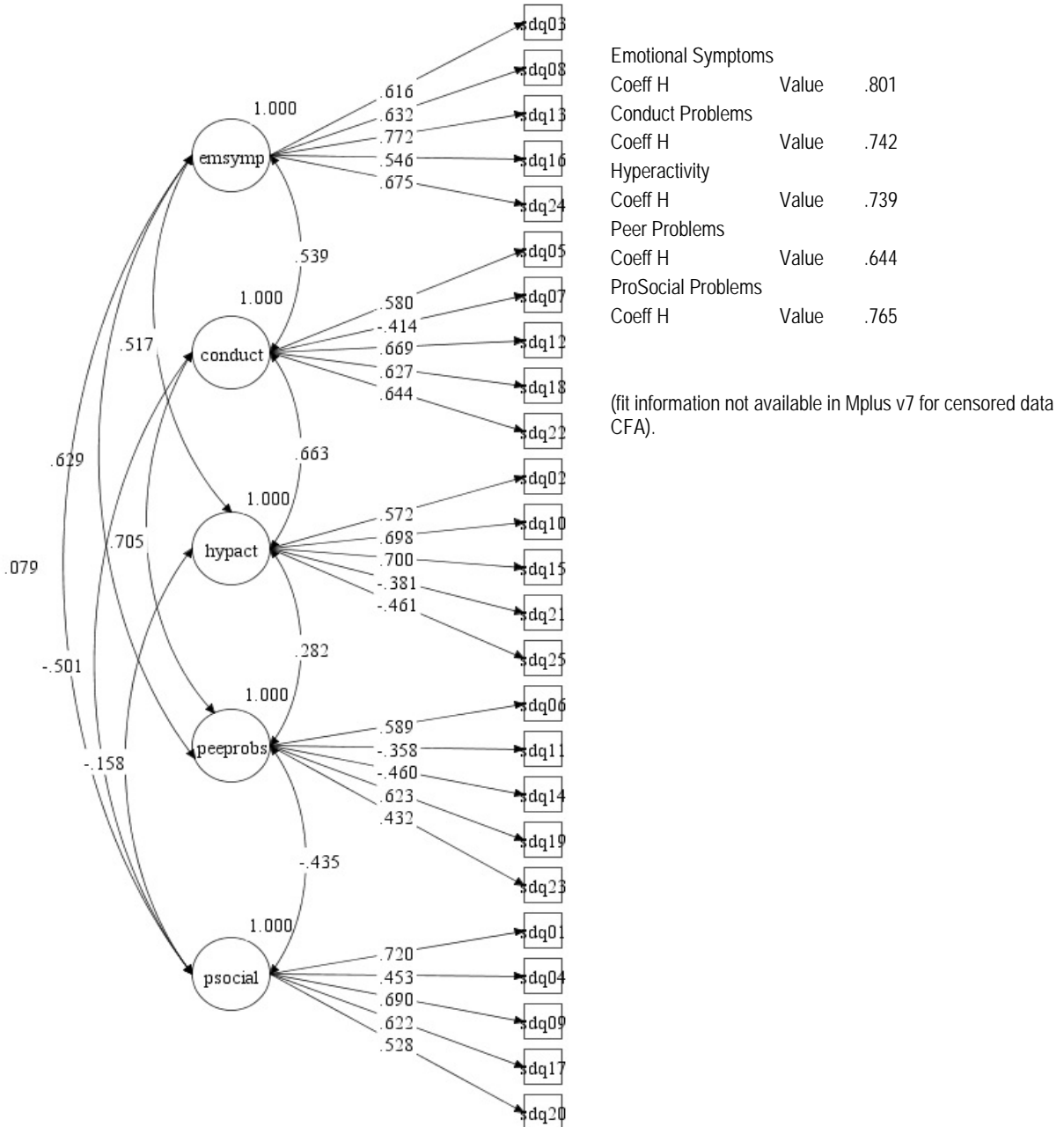

Appendix B Figure 14 SDQ Model

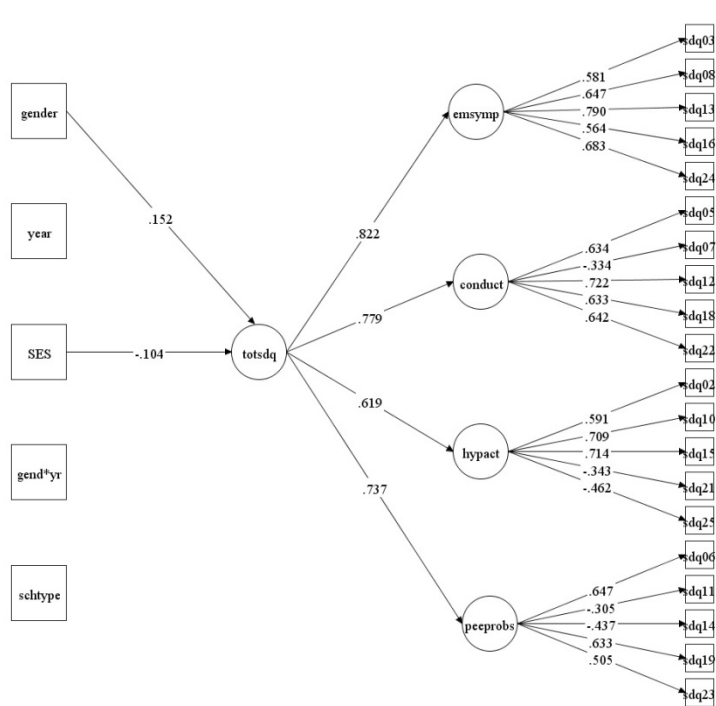

(fit information not available in Mplus v7 for censored data MIMIC).

Appendix B Figure 15 Influence of covariates on Total SDQ (MIMIC model)