

Eur Respir J, 1995, 8, 1910–1914  
 DOI: 10.1183/09031936.95.08111910  
 Printed in UK - all rights reserved

Copyright ©ERS Journals Ltd 1995  
 European Respiratory Journal  
 ISSN 0903 - 1936

## Detection of flow limitation during tidal breathing by the interruptor technique

R. Hage, J.G.J.V. Aerts, A.F.M. Verbraak, B. van den Berg, J.M. Bogaard

*Detection of flow limitation during tidal breathing by the interruptor technique. R. Hage, J.G.J.V. Aerts, A.F.M. Verbraak, B. van den Berg, J.M. Bogaard. © ERS Journals Ltd. 1995.*

**ABSTRACT:** In patients with airflow obstruction, flow limitation can be established in various ways. Using body plethysmography, flow limitation is assumed when expiratory flow decreases whilst alveolar pressure increases at the same time. During forced expiration, flow limitation can be established by means of the flow interruptor technique; flow limitation is assumed when, after release of an occlusion, a spike flow superimposed on the ongoing alveolar flow ( $\Delta$ peak flow) is detected. In this study, the flow interruptor technique was applied to detect flow limitation during tidal breathing. The results were compared to those obtained with the body plethysmograph.

The expiratory flow pattern, post-interruption, was analysed in 33 subjects; 11 patients with airflow obstruction and flow limitation established with the body plethysmograph (AO+); 11 patients with airflow obstruction without flow limitation (AO-); and 11 healthy volunteers.

Mean spike areas were  $27.6 \pm 18.3$ ,  $4.6 \pm 2.3$  and  $3.4 \pm 2.0$  mL for the AO+, AO- and control group, respectively, showing a highly significant difference between the AO+ patients and the other groups. Also, significantly higher  $\Delta$ peak flows were found in the AO+ patients compared to the other groups. No differences in  $\Delta$ peak flows or spike areas could be established between patients without flow limitation and controls.

We conclude that the interruptor technique may be a useful means of assessing flow limitation during tidal breathing.

*Eur Respir J., 1995, 8, 1910–1914.*

Dept of Pulmonary Diseases and Respiratory Intensive Care Unit, University Hospital Dijkzigt, Erasmus University, Rotterdam, The Netherlands.

Correspondence: J.M. Bogaard  
 Dept Pulmonary Function, V207  
 University Hospital Dijkzigt  
 Dr. Molewaterplein 40  
 3015 GD Rotterdam  
 The Netherlands

Keywords: Flow limitation  
 interruptor method  
 spontaneous breathing

Received: July 26 1994  
 Accepted after revision June 4 1995

Supported by Nederlands Astma Fonds (the Dutch Asthma Foundation)

The interruptor technique to estimate airways resistance was first described by VON NEERGAARD and WIRZ [1]. The mouth pressure measured at the end of a short interruption of expiratory flow was assumed to be equal to alveolar pressure. From the ratio between this mouth pressure and flow immediately before the interruption, airways resistance was estimated [1].

The collapsibility of the airways can also be established by application of the interruptor technique, from the overshoot or spike in the flow pattern after reopening of the interruptor. During an occlusion, a compressed airway or a flow limiting segment (FLS) will be abolished. After opening of the interruptor valve, the FLS re-establishes, and this can be assessed by the expiratory flow pattern. The flow due to the reappearance of the compressed airways segment is assumed to be superimposed on the ongoing mouth flow. In various studies, this analysis has been validated, during forced expiratory flow limitation, in healthy subjects [2, 3]. In addition to healthy subjects, it has been suggested that flow limitation can be present during quiet breathing in mechanically-ventilated patients [4, 5]. The analysis of the expiratory flow after interruption has been used

in a qualitative way to demonstrate flow limitation during mechanical ventilation [6, 7].

To our knowledge, no validation of the interruptor method to establish flow limitation has been performed in patients, during quiet breathing, in whom the presence of flow limitation was demonstrated by an independent method. Therefore, we compared the flow magnitude and area under the curve of the spike flow in spontaneously breathing healthy volunteers and patients with airflow obstruction, with (AO+) and without (AO-) flow limitation. The presence of flow limitation during expiration was assumed from the time course of alveolar pressure and expiratory flow determined in a whole body plethysmograph.

### Patients and methods

#### Subjects

A total of 33 subjects was studied. Airflow obstruction was based on a clinical history of chronic obstructive pulmonary disease (COPD), with or without emphysema,

asthma or cystic fibrosis (CF). One group (Group A) of 11 patients (10 males and 1 female) suffered from airflow obstruction with flow limitation during part of the expiratory phase (AO+), as established with body plethysmography; mean age 51 yrs (range 28–75 yrs). Another group (Group B) of 11 patients (8 males and 3 females) suffering from airflow obstruction had no flow limitation during expiration (AO-); mean age 39 yrs (range 19–71 yrs). Additionally, 11 nonsmoking healthy volunteers (8 males and 3 females) mean age 36 yrs (range 17–77 yrs) were included in the study (Group C).

The group of AO+ patients included three patients with chronic airflow obstruction due to CF, five had a clinical diagnosis of emphysema, and in one patient emphysema was due to  $\alpha_1$ -antitrypsin deficiency.

The group of AO- patients included seven patients with CF. None of the volunteers suffered from diseases of cardiopulmonary origin. All subjects gave informed consent.

### Lung function

With a heated pneumotachometer system (Jaeger, Würzburg, Germany) forced expiratory volume in one second (FEV<sub>1</sub>) and inspiratory vital capacity (VC) were determined. Before each measurement, volume calibration was performed and volumes were corrected to body temperature, atmospheric pressure and saturation with water vapour (BTPS) conditions.

### Body plethysmography

A volume-constant body plethysmograph (Jaeger, Bodytest, Würzburg, Germany) was used to determine functional residual capacity (FRC) and airways resistance, and to establish the presence of flow limitation during expiration. All data were sampled and stored on a personal computer at a frequency of 100 Hz. The subjects were seated in the closed box for 2 min to allow stabilization of the box pressure ( $P_{\text{box}}$ ) fluctuations. Thereafter, they were asked to pant with a frequency of 0.5–1.0 Hz against a closed shutter. Applying Boyle's law, both the intrathoracic gas volume (ITGV) and the conversion factor from  $P_{\text{box}}$  to alveolar pressure ( $PA$ ) changes were determined. FRC was calculated from the ITGV determination. The effective resistance ( $R_{\text{eff}}$ ) was determined from flow and  $P_{\text{box}}$  changes during breathing in a heated and humidified rebreathing bag, keeping the inspiratory and expiratory flow at BTPS conditions [8]. In each patient, three reproducible body plethysmographic measurements were performed. In most obstructive patients, the  $PA/\text{flow}$  ( $V'$ ) relationship shows a complex impedance behaviour, therefore the derived  $R_{\text{eff}}$  can be considered as a measure of the energy dissipation (resistive behaviour) during a breathing cycle. In an earlier investigation,  $R_{\text{eff}}$  proved to be the most reliable resistance variable in these circumstances [8]. During the rebreathing procedure, the lung volume changes were taken into account in the  $R_{\text{eff}}$  estimation.

### Presence of flow limitation from body plethysmography

Flow limitation was assumed to be present when a decrease in flow occurred during expiration, together with an increase in  $PA$ . This could be recognized from the characteristic looping pattern in the body plethysmogram during expiration (fig. 1a). To determine the time interval in which flow limitation was present during an expiration, the following procedure was used. A third degree polynomial was fitted to both the  $V'$  and  $PA$  time course. From the calculated time derivatives,  $dPA(t)/dt$  and  $dV'(t)/dt$ ,  $dPA/dV'$  was calculated as  $(dPA(t)/dt)/(dV'(t)/dt)$ . During the time interval in which  $dPA/dV'$  was negative, flow limitation was assumed to be present. Figure 1b shows the actual  $PA(t)$  and  $V'(t)$ , the polynomial fits and the time interval of flow limitation associated with the body plethysmogram presented in figure 1a.

### The interruptor technique

The interruptor (4200 series Type TM 7/8 Hans Rudolph Inc., Kansas City, MO, USA) consists of a sliding pneumatic piston. In series with the interruptor, flow was measured with a heated pneumotachometer (Lilly) (fig. 2). Mouth pressure was measured (Validyne P45 transducer, Validyne, Northridge, USA) proximal to the interruptor valve. Pressure and flow signals were stored on a personal computer with a sample frequency of 500 Hz.

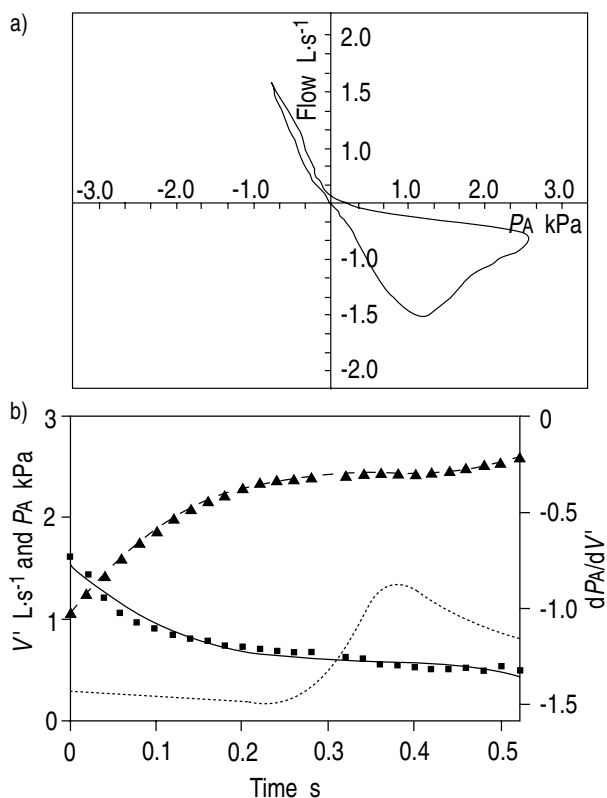

Fig. 1. — a) Body plethysmography pattern representative of a patient with airflow obstruction and flow limitation (AO+). b) Actual alveolar pressure ( $PA$ ) and  $V'$ -time recording, the polynomial fits and  $dPA/dV'$ -time interval of the body plethysmogram presented in 1a. ■ : flow ( $V'$ ); — : polynomial fit of the flow signal; ▲ : alveolar pressure ( $PA$ ); - - - : polynomial fit of the  $PA$ -time signal; ..... :  $dPA/dV'$ .

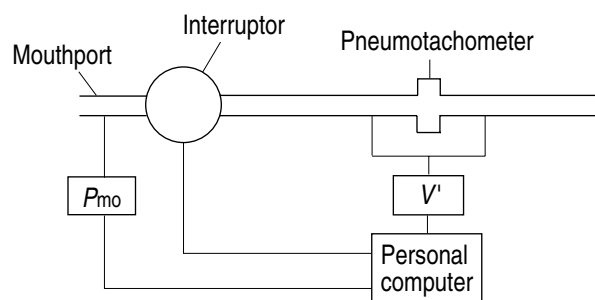

Fig. 2. – Schematic presentation of interruption measurement.  $V'$ : flow;  $P_{mo}$ : mouth pressure.

The opening and closing of the piston was computer controlled. The switching speed, defined as the time elapsed from complete opening to closure was 65–110 ms.

OHYA *et al.* [3] performed interruptions of variable length during forced expirations in healthy volunteers with flow limitation. They found a triphasic pattern in the time course of mouth pressure. The first phase consisted of a rapid rising pressure representing pressure equilibration of upper airway segments. During this phase, an airflow into the re-expanding compressed airway segment was assumed. The second phase consisted of a slower rising pressure during which the airway wall further expanded from its compressed state. In the third phase, equilibration between alveolar and mouth pressure was completed. Reopening of the interruptor after closure of more than 0.1 s yielded equal flow spikes. This indicates that, within that period, the expansion of the compressed airway segment has been completed [3].

In our investigation, flow was interrupted for 0.25 s, permitting the compressed segment to be fully expanded to the uncompressed state.

All subjects, provided with noseclip, were studied in sitting position, supporting cheeks and mouth floor with their hands, in order to keep the distensibility of the extrathoracic airways as low as possible [9]. About 30 interruptions were performed, one interruption per expiration, randomly distributed over the expiratory phase.

Flow at the onset of interruption (occlusion flow) and after reopening maximal flow, flow overshoot ( $\Delta$ peak flow) and volume displacement associated with the flow overshoot (spike area) were obtained from three representative recordings within the interval of flow limitation derived from body plethysmography (fig. 3). In case of absence of flow limitation, three recordings were used

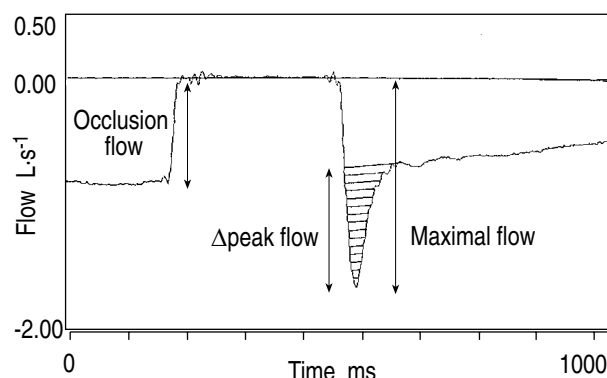

Fig. 3. – Interruption pattern with  $\Delta$ peak flow, maximal flow, occlusion flow and spike area (shaded area).

within the same time interval, as mentioned above. The flow overshoot was determined after back-extrapolation of the flow during the interval 0.1–0.4 s after reopening of the interruptor. The spike area was obtained by integration of the flow overshoot.

#### Measuring device accuracy and dynamic properties

To study the dynamic properties of the interruptor device and measuring equipment, a constant flow generator was used. The interruption procedure was performed as in the patient measurements. A tubing connected to the pressure transducer of the pneumotachometer was used with a length and a resistance such that the flow response after reopening of the interruptor was critically damped. Ninety percent rise time was less than 25 ms, which was considered sufficiently accurate for the purpose of the measurements.

#### Statistical methods

Comparisons between mean values of the three groups were made using analysis of variance, assuming significance at a p-value of less than 0.05.

### Results

The body plethysmographic and interruption measurement were completed in all 33 subjects.

Table 1 shows the mean FEV<sub>1</sub>, VC,  $R_{eff}$  and functional residual capacity/total lung capacity ratio (FRC/TLC)

Table 1. – Pulmonary function data of the three groups studied

| Parameters                       | AO+                      | AO-                      | C                        | p-value    |          |          |
|----------------------------------|--------------------------|--------------------------|--------------------------|------------|----------|----------|
|                                  | n=11                     | n=11                     | n=11                     | AO+ vs AO- | AO+ vs C | AO- vs C |
| FEV <sub>1</sub> % pred          | 55±19<br>(31–87)         | 76±22<br>(39–130)        | 101±12<br>(84–132)       | <0.005     | <0.0001  | <0.005   |
| VC % pred                        | 88±21<br>(59–118)        | 91±12<br>(72±116)        | 102±13<br>(84–136)       | NS         | NS       | NS       |
| $R_{eff}$ kPa·s <sup>-1</sup> ·L | 0.83±0.49<br>(0.22–1.93) | 0.33±0.14<br>(0.18–0.64) | 0.20±0.06<br>(0.10–0.26) | <0.005     | <0.001   | <0.01    |
| FRC/TLC                          | 0.72±0.10<br>(0.57–0.87) | 0.66±0.10<br>(0.47–0.82) | 0.58±0.07<br>(0.45–0.65) | NS         | <0.005   | <0.05    |

Values are presented as mean±SD, and range in parenthesis. AO+: patients with airflow obstruction and flow limitation; AO-: patients with airflow obstruction and without flow limitation; C: controls. FEV<sub>1</sub>: forced expiratory volume in one second; VC: vital capacity;  $R_{eff}$ : effective resistance; FRC/TLC: functional residual capacity/total lung capacity ratio; NS: nonsignificant. Significance of difference is indicated.

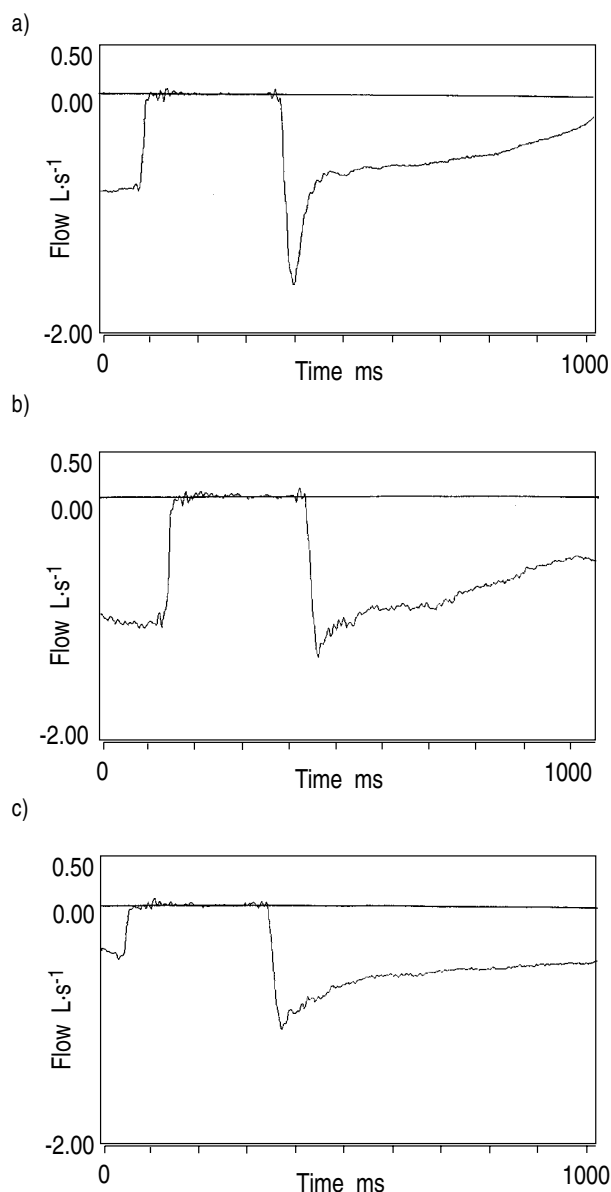

Fig. 4. – Representative interruption pattern of: a) a patient with airflow obstruction and flow limitation (AO+); b) a patient with airflow obstruction and without flow limitation (AO-); and c) a healthy control.

Table 2. – Occlusion flow, maximal flow,  $\Delta$ peak flow and spike area for the three groups studied derived from the interruptor measurement

|                                       | AO+                      | AO-                   | C                      | p-value    |          |          |
|---------------------------------------|--------------------------|-----------------------|------------------------|------------|----------|----------|
|                                       |                          |                       |                        | AO+ vs AO- | AO+ vs C | AO- vs C |
| Occlusion flow mL·s <sup>-1</sup>     | 646±155<br>(422–1005)    | 496±116<br>(357–697)  | 623±216<br>(266–975)   | <0.05      | NS       | NS       |
| Maximal flow mL·s <sup>-1</sup>       | 1747±633<br>(1152–3309)  | 934±185<br>(693–1333) | 1267±420<br>(559–1840) | <0.001     | <0.05    | <0.05    |
| $\Delta$ peak flow mL·s <sup>-1</sup> | 954±676<br>(532–2905)    | 203±76<br>(101–297)   | 211±115<br>(72–415)    | <0.005     | <0.005   | NS       |
| Spike area mL                         | 27.6±18.3<br>(10.6–70.8) | 4.6±2.3<br>(1.3–6.3)  | 3.4±2.0<br>(1.0–6.9)   | <0.001     | <0.0005  | NS       |

Data are presented as mean±SD and range in parenthesis. For abbreviations see legend to table 1. Significance of differences is indicated.

values of the subjects studied. In the AO+ and AO- patients, mean FEV<sub>1</sub> (% of predicted) was significantly lower, and mean  $R_{eff}$  and mean FRC/TLC ratios were significantly higher, than in the control group. Mean  $R_{eff}$  was significantly higher and FEV<sub>1</sub> significantly lower in the AO+ patients compared to the AO- patients. With respect to the mean VC values, no significant differences were found between the three groups.

The polynomial fits of the  $PA$  and  $V'$  time-course during the last 75% of expiration, during which flow limitation was assumed, yielded mean values of  $r^2$  (coefficient of determination) of 0.96 (range 0.80–0.99) and 0.97 (range 0.81–0.99), respectively.

Figure 4a–c shows representative examples of flow patterns during closure and reopening of the interruptor in an AO+ patient, an AO- patient, and a healthy subject.

Analysis of the variables shown in figure 3 yielded the mean values given in table 2. Both the  $\Delta$ peak flow and spike area were found to be significantly higher in the AO+ patients compared to the AO- patients and to the controls. No significant differences in  $\Delta$ peak flow and in spike area were present between the AO- patients and the control group.

Maximal expiratory flow was significantly higher in the AO+ patients compared to the other two groups. In the AO- patients, maximal expiratory flow was significantly lower compared to the controls. The occlusion flow was only significantly higher in the AO+ patients compared to the AO- patients.

Within the group of AO+ patients, no significant correlation between spike area and FEV<sub>1</sub> or between spike area and  $R_{eff}$  was found.

End-occlusion mouth plateau pressure ranged 0.5–3 kPa in the three groups.

## Discussion

In this study, the applicability of the interruptor method to establish quantitative indices for flow limitation was assessed during quiet breathing.

It is assumed that interruption of expiratory flow will abolish the flow limiting segment and that flow

limitation will be reinstated after opening of the valve, which is demonstrated by an overshoot in expiratory flow [3, 6, 7]. We have applied the interruptor method in patients with airflow obstruction, with (AO+) and without (AO-) flow limitation, and in healthy volunteers, during quiet breathing. The presence or absence of a compressed airway segment, and consequently flow limitation, was established using whole body plethysmography. During plethysmography, flow limitation was defined as an increasing  $PA$  accompanied with a decreasing  $V'$ , leading to a negative  $dPA/dV'$  ratio. A third degree polynomial was fitted through the  $PA$  and  $V'$  time curves in order to describe the presence of flow limitation in time mathematically as  $dPA/dV'$ . In all cases, an accurate fit was obtained considering the  $r^2$  values and, consequently, calculation of  $dPA/dV'$  versus time could be used to assess the presence of flow limitation. A flow limiting segment was probably even present when  $dPA/dV'$  was slightly above zero.

From the interruptor flow time curve, the  $\Delta$ peak flow and the spike area were calculated. In previous investigations, the presence of flow overshoots has been ascribed to decompression of extrathoracic airways, restoration of the compressed airway segment, and ongoing alveolar flow [2, 3, 10, 11].

Quantitative data from spike areas have been obtained in healthy volunteers during forced expiration. KNUDSON *et al.* [10], excluding the influence of the extrathoracic airways by a head canopy, found compressed volumes between 50 and 150 mL. OHYA *et al.* [3] determined spike areas of about 100 mL after occlusions at 50% FVC. Based on the anatomy of the bronchial tree, the decompression volume of the extrathoracic airways was assumed to be 10 mL in case of an alveolar pressure of about 10 kPa [12]. In our study, end-occlusion pressures ranged from 0.5–3 kPa; consequently, the spike-areas in the AO- patients and in the healthy volunteers are most probably due to decompression of gas in extrathoracic airways.

During the generation of a flow limiting segment, the ongoing alveolar flow affects the spike area, as has been demonstrated by PEDERSEN *et al.* [11]. Considering earlier findings in healthy volunteers during forced expiration and scarce data on patients with airflow obstruction during forced expiration, it has been suggested that the presence of flow limitation provides the main contribution [2, 3, 10]. However, in this study, in the patients with flow limitation, no relationship between spike area and  $R_{eff}$  neither between spike area and FEV<sub>1</sub> has been found.

In this study, the post-interruption flow pattern was analysed in order to obtain indices for flow limitation from this flow pattern. Maximal expiratory flow was found to be significantly different among the three patient groups studied, indicating that maximal expiratory flows cannot be used to establish the presence or absence of flow limitation. The occlusion flow was higher in AO+ patients compared to AO- patients, a finding which remains to be explained.

The large differences in  $\Delta$ peak flow and spike area comparing AO+ patients to AO- patients and healthy

volunteers, and the absence of differences in these parameters between AO- patients and healthy volunteers, indicate the feasibility of deriving quantitative indices for flow limitation.

Further research is needed to establish the value of analysis of  $\Delta$ peak flow and spike area using an interruptor measurement in clinical practice. Because the interruptor measurement requires minimal subject cooperation, is easy to perform, and can be carried out during tidal breathing, it offers a feasible alternative to conventional lung function measurements for detection of the presence of flow limitation, such as in critically ill patients and in neonates [6, 7, 13, 14].

## References

1. Von Neergaard K, Wirz K. Die Messung der Strömungswiderstände in den Atemwegen des Menschen, insbesondere bei Asthma und Emphysem. *Z Klin Med* 1927; 105: 51–82.
2. Ohya N, Huang J, Fukunaga T, Toga H. Airway pressure-volume curve estimated by flow interruption during forced expiration. *J Appl Physiol* 1989; 67: 2631–2638.
3. Ohya N, Huang J, Fukunaga T, Toga H. Mouth pressure curve on abrupt interruption of airflow during forced expiration. *J Appl Physiol* 1989; 66: 509–517.
4. Rossi A, Brandolese R, Milic-Emili J, Gottfried SB. The role of PEEP in patients with chronic obstructive pulmonary disease during assisted ventilation. *Eur Respir J* 1989; 3: 818–822.
5. Gay PC, Rodarte JR, Hubmayr RD. The effects of positive expiratory pressure on isovolume flow and dynamic hyperinflation in patients receiving mechanical ventilation. *Am Rev Respir Dis* 1989; 139: 621–626.
6. Gottfried SB, Rossi A, Higgs BD, *et al.* Noninvasive determination of respiratory system mechanics during mechanical ventilation for acute respiratory failure. *Am Rev Respir Dis* 1985; 131: 414–420.
7. Reinoso AR, Gracey DR, Hubmayr RD. Interrupter mechanics of patients admitted to a chronic ventilator dependency unit. *Am Rev Respir Dis* 1993; 148: 127–131.
8. Holland WPJ, Verbraak AFM, Bogaard JM, Boender W. Effective airway resistance: a reliable variable from body plethysmography. *Clin Phys Physiol Meas* 1986; 7: 319–331.
9. Liistro G, Stănescu D, Rodenstein D, Veriter C. Re-assessment of the interruption technique for measuring flow resistance in humans. *J Appl Physiol* 1989; 67: 933–937.
10. Knudson RJ, Mead J, Knudson DE. Contribution of airway collapse to supramaximal expiratory flows. *J Appl Physiol* 1974; 36: 653–667.
11. Pedersen OF, Lyager S, Ingram RH jr. Airway dynamics in transition between peak and maximal expiratory flow. *J Appl Physiol* 1985; 59: 1733–1746.
12. Takizawa T. Morphology of the bronchial tree. *Respir Circ* 1971; 19: 755–760.
13. Guérin C, Coussa M-L, Eissa NT, *et al.* Lung and chest wall mechanics in mechanically-ventilated COPD patients. *J Appl Physiol* 1993; 74: 1570–1580.
14. Merth IT, Quanjer PhH. Respiratory system compliance assessed by the multiple occlusion and weighted spirometer method in non-intubated healthy newborns. *Pediatr Pulmonol* 1990; 8: 273–279.