

Technical University of Denmark



## Effects of Floor Covering Resistance of a Radiant Floor on System Energy and Exergy Performances

**Kazanci, Ogun Berk; Shukuya, Masanori; Olesen, Bjarne W.**

*Published in:*  
CLIMA 2016 - Proceedings of the 12th REHVA World Congress

*Publication date:*  
2016

*Document Version*  
Peer reviewed version

[Link back to DTU Orbit](#)

*Citation (APA):*  
Kazanci, O. B., Shukuya, M., & Olesen, B. W. (2016). Effects of Floor Covering Resistance of a Radiant Floor on System Energy and Exergy Performances. In P. Kvols Heiselberg (Ed.), CLIMA 2016 - Proceedings of the 12th REHVA World Congress (Vol. 10, Chapter ). [27]

**DTU Library**  
Technical Information Center of Denmark

---

### General rights

Copyright and moral rights for the publications made accessible in the public portal are retained by the authors and/or other copyright owners and it is a condition of accessing publications that users recognise and abide by the legal requirements associated with these rights.

- Users may download and print one copy of any publication from the public portal for the purpose of private study or research.
- You may not further distribute the material or use it for any profit-making activity or commercial gain
- You may freely distribute the URL identifying the publication in the public portal

If you believe that this document breaches copyright please contact us providing details, and we will remove access to the work immediately and investigate your claim.

# Effects of Floor Covering Resistance of a Radiant Floor on System Energy and Exergy Performances

Ongun B. Kazanci\*<sup>1</sup>, Masanori Shukuya<sup>2</sup>, Bjarne W. Olesen<sup>1</sup>

<sup>1</sup> International Centre for Indoor Environment and Energy – ICIEE, Department of Civil Engineering, Technical University of Denmark, Nils Koppels Allé, Building 402, 2800 Kgs. Lyngby, Denmark

\*[onka@byg.dtu.dk](mailto:onka@byg.dtu.dk)

[bwo@byg.dtu.dk](mailto:bwo@byg.dtu.dk)

<sup>2</sup> Department of Restoration Ecology and Built Environment, Tokyo City University, 3-3-1 Ushikubo-nishi, Tsuzuki-ku, Yokohama, 224-8551 Japan

[m.shukuya@gmail.com](mailto:m.shukuya@gmail.com)

## Abstract

*Floor covering resistance (material and thickness) can be influenced by subjective choices (architectural design, interior design, texture, etc.) with significant effects on the performance of a radiant heating and cooling system. To study the effects of floor covering resistance on system performance, a water-based radiant floor heating and cooling system (dry, wooden construction) was considered to be coupled to an air-to-water heat pump, and the effects of varying floor covering resistances (0.05 m<sup>2</sup>K/W, 0.09 m<sup>2</sup>K/W and 0.15 m<sup>2</sup>K/W) on system performance were analyzed in terms of energy and exergy.*

*In order to achieve the same heating and cooling outputs, higher average water temperatures are required in the heating mode (and lower temperatures in the cooling mode) with increasing floor covering resistance. These temperature requirements decrease the heat pump's performance (lower coefficient of performance). This requires higher electricity input to the heat pump, corresponding to an increased exergy demand and consumption, to achieve the same space heating or cooling.*

*The required exergy input to the system (power plant where the electricity is generated) increased by 14% and 5% for heating and cooling, respectively. Increased floor covering resistance has a similar effect to an increased space heating or cooling load, on the water side of the radiant system while in fact the space heating and cooling loads are not changing.*

*The floor covering resistance should be kept to a minimum in order not to hinder the performance of the floor heating/cooling and the whole system and to benefit from the low temperature heating and high temperature cooling potential.*

**Keywords - radiant floor heating/cooling; floor covering resistance; exergy; heat pump COP**

## 1. Introduction

Among the air-based and water-based systems used to heat or cool the indoor spaces of buildings, low temperature heating and high temperature cooling systems emerge as an energy-efficient solution. One example of these systems is radiant heating and cooling systems (floor, ceiling and wall heating/cooling). In addition to energy-efficiency, radiant systems create thermally comfortable indoor environments by minimizing the risk of unpleasant air movement, and by creating a uniform thermal indoor environment [1], [2].

There are several factors that affect the performance of radiant systems and surface covering resistance (material and thickness) is one of them. Several authors studied the effects of floor covering on radiant floors [3], [4], [5]. After a parametric study, Sattari and Farhanieh [5] concluded that the type and thickness of the floor covering are the most important parameters in the design of radiant heating systems.

The floor covering material can be a subjective choice (architectural design, interior design, texture, etc.) with significant effects on the performance of a radiant heating and cooling system.

In this study, a floor heating and cooling system coupled to a reversible air-to-water heat pump was studied theoretically to quantify the effects of the floor covering resistance on the whole system performance in terms of energy and exergy. The floor heating and cooling system was installed in a single-family house and the same floor structure was used while the floor covering resistance varied. The coefficient of performance (COP) of the heat pump and the exergy input to the power plant were used to compare the effects.

## 2. System Description and Determination of the Key Parameters

The chosen floor heating and cooling system was installed in a single-family house, assumed to be in Denmark for the calculations. The construction details, details of the heating, cooling, and ventilation system of the actual house are given in [6], [7].

The house was heated and cooled by the hydronic radiant floor, using the low temperature heating and high temperature cooling principle. The floor heating and cooling system was a dry radiant system, consisting of a piping grid installed in the wooden layer. The details of the floor system were: chipboard elements, with aluminum heat conducting profiles (thickness 0.3 mm and length 0.17 m), PE-X pipe, 17x2.0 mm. Pipe spacing was 0.2 m. The available floor area for the embedded pipe system installation was 45 m<sup>2</sup>, which is 68% of the total floor area. Fig. 1 shows the details of the floor structure.

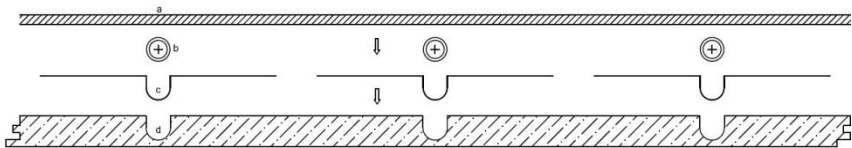

Fig. 1 a) Floor covering b) Pipe, 17x2.0 mm c) Heat distribution plate, 0.3 mm, d) Under-floor plate, 22 mm

The floor heating and cooling system was coupled to a reversible air-to-water heat pump. The minimum and maximum cooling capacities and the nominal power input in the cooling mode were 4.0, 7.1, and 2.9 kW, respectively. The minimum and maximum heating capacities and the nominal power input in the heating mode were 4.1, 7.8, and 2.8 kW, respectively.

The coefficient of performance (COP) of the heat pump was obtained from the manufacturer’s datasheets as a function of outdoor air temperature and the temperature of the water leaving the evaporator or condenser (assumed equal to the supply water temperature to the floor loops).

The house was ventilated mechanically with a ventilation rate of 0.5 ach. The supply air temperature was 16.3°C in winter and 21.3°C in summer.

Fig. 2 shows the schematic drawings of the studied heating and cooling systems.

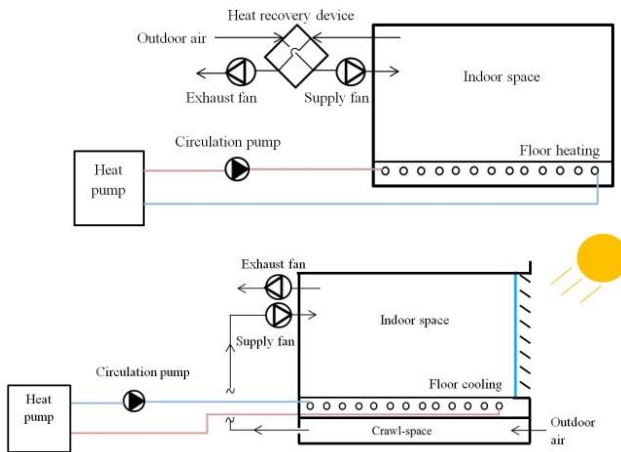

Fig. 2 Schematic drawings of the heating (top) and cooling (bottom) systems

The effect of the floor covering resistance on the whole system performance was studied through different floor covering resistances. The same floor structure was used with different thermal resistances: 0.05 m<sup>2</sup>K/W (LoRes), 0.09 m<sup>2</sup>K/W (actual value, MRes), and 0.15 m<sup>2</sup>K/W (HiRes), following the most common values given in respective standards [8]. The same floor covering material was used (thermal conductivity is 0.13 W/mK, wooden floor covering), but with 0.0065 m, 0.012 m and 0.0195 m thickness, respectively. For each resistance value, a new water supply temperature was calculated.

The space heating and cooling loads were 2180 W (48.4 W/m<sup>2</sup>-heated floor area) and 876 W (19.5 W/m<sup>2</sup>-cooled floor area), respectively. The heating and cooling outputs from the floor, required floor surface temperatures and the mass flow rates were calculated according to [8], [9], [10], [11].

For floor heating, the required surface temperature was 24.7°C and mass flow rate was 469 kg/h. For floor cooling, the required surface temperature was 23.2°C and the mass flow rate was 250 kg/h. The temperature difference between the supply and return water flows was 4°C for heating cases and 3°C for cooling cases. The heat losses to and gains from the other side of the structure were neglected. Full details of the load calculations are given in [6], [12].

### 3. Exergy Calculation Methodology

Exergy analysis methodology described by Shukuya [13] was used. In this paper only the calculations for heating season are described; cooling season calculations follow a similar approach and are described in detail in [12].

The calculations were carried out manually, under steady-state conditions. The outdoor temperatures were -5°C and 30°C, in winter and summer conditions, respectively, and these temperatures were also the environmental (reference) temperatures in the exergy calculations. The indoor temperatures (air and mean radiant) were 20°C and 26°C, in winter and summer conditions, respectively.

The exergy balance for a system under steady-state condition is

$$[\text{Exergy input}] - [\text{Exergy consumed}] = [\text{Exergy output}] \quad (1)$$

where  $[\text{Exergy consumed}] = [\text{Entropy generated}] \cdot T_o$ , and  $T_o$  is the environmental (reference) temperature [K].

Heating exergy load [14] is the exergy requirement that the heating system has to address and it is defined as

$$X_{\text{heating}} = Q_{\text{heating}} (1 - T_o/T_i) \quad (2)$$

where  $X_{\text{heating}}$  is the heating exergy load [W],  $Q_{\text{heating}}$  is the space heating load [W], and  $T_i$  is indoor temperature (air and mean radiant temperatures) [K].

The rate of exergy supplied to the indoor space from the heated floor surface is calculated as

$$X_{\text{FH,out}} = Q_{\text{heating}} (1 - T_o/T_{\text{S,FH}}) \quad (3)$$

where  $X_{\text{FH,out}}$  is the exergy supplied from floor heating to the indoors [W], and  $T_{\text{S,FH}}$  is the average temperature of the heated floor surface [K].

Exergy consumed in the indoor space is the difference between the exergy supplied indoors,  $X_{\text{FH,out}}$ , and the heating exergy load,  $X_{\text{heating}}$ .

The exergy consumption in the floor structure is obtained from the exergy balance equation as

$$\Delta X_w - X_c = X_{\text{FH,out}} \quad (4)$$

$$\Delta X_w = X_{w,\text{supply}} - X_{w,\text{return}} \quad (5)$$

where  $\Delta X_w$  is the difference between the rate of exergy of the supply and return water (net exergy input to the floor structure) [W],  $X_{w,\text{supply}}$  is the exergy of the supply water flow into the floor [W],  $X_{w,\text{return}}$  is the exergy of the return water flow from the

floor [W],  $X_c$  is the exergy consumption rate within the floor structure [W], and  $X_{FH,out}$  is the exergy supplied to indoors from the heated floor surface [W], given by Eq. (3).

The exergy of the supply and return water flows are calculated as

$$X_w = V_w c_w \rho_w \{(T_w - T_o) - T_o \ln (T_w / T_o)\} \quad (6)$$

where  $X_w$  is the exergy of the water flow [W],  $V_w$  is the volumetric flow rate of water [m<sup>3</sup>/s],  $c_w$  is the specific heat capacity of water [J/kgK],  $\rho_w$  is the density of water [kg/m<sup>3</sup>], and  $T_w$  is the temperature of water [K].

It was assumed that the electricity supplied to the heat pump was generated in a remote, natural gas fired power plant. The exergy input to the power plant by natural gas is calculated as follows.

$$E_{HP} = Q_{heating} / COP \quad (7)$$

$$X_{in,power\ plant} = r (E_{HP} / \eta_{TOT}) \quad (8)$$

where  $E_{HP}$  is power (electricity) input to the heat pump [W], COP is the coefficient of performance of the heat pump,  $X_{in,power\ plant}$  is the exergy input to the power plant through natural gas [W],  $\eta_{TOT}$  is the total efficiency including conversion efficiency of the power plant, distribution and transmission efficiencies of the grid (taken as 0.35 [13]), and  $r$  is the ratio of chemical exergy to higher heating value of natural gas (taken as 0.93 [13]).

#### 4. Results and Discussion

Table 1 summarizes the supply and return water temperatures to obtain the required floor surface temperatures, corresponding heat pump COP and the relative change in COP.

Table 1. Supply and return water temperatures and COP values

	Supply temperature [°C]	Return temperature [°C]	COP [-]	Change in COP
FH_LoRes	33	29	2.63	-
FH_MRes	35.8	31.8	2.48	-6%
FH_HiRes	39.8	35.8	2.31	-12%
FC_LoRes	18.6	21.6	3.42	-
FC_MRes	17.2	20.2	3.35	-2%
FC_HiRes	15.9	18.9	3.28	-4%

Fig. 3 and Fig. 4 show the whole chains of exergy flows for heating and cooling cases.

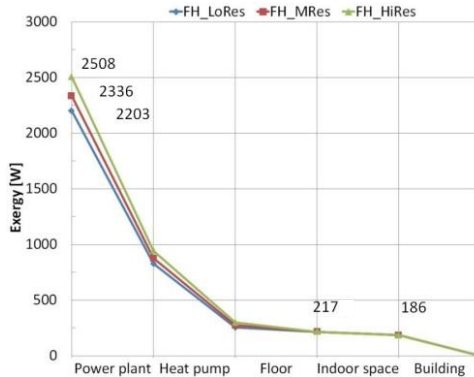

Fig. 3 Exergy flows for the floor structures with different floor covering resistances, heating

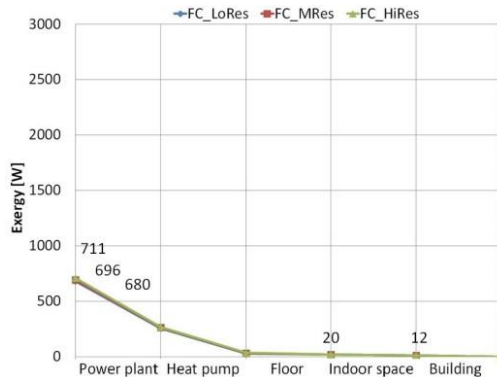

Fig. 4 Exergy flows for the floor structures with different floor covering resistances, cooling

The results show that higher floor covering resistance hinders the performance of the floor heating and cooling systems. In order to obtain the same space heating or cooling effect, higher electricity input is required to the heat pump with increased floor covering resistance. This means that a higher exergy input is necessary to the power plant where the electricity is generated. This is because a higher floor covering resistance requires higher average water temperature for the floor heating system and a lower average water temperature for the floor cooling system, to obtain the same floor surface temperature to provide the necessary space heating and cooling, respectively.

This physical behavior leads to a higher condensing temperature in heating and a lower evaporation temperature in cooling mode for the heat pump, decreasing the heat pump performance (lowering the COP).

For different floor covering resistances, the energy coming into the floor structure (heat emitted to or removed from the indoor space) is the same but the exergy is different. This inevitably results in increased exergy supply to and consumption within

the floor structure. In floor heating, compared to the low resistance case, in which 41 W is consumed, the exergy consumption increased by 42% and almost doubled for the cases with mid- and high floor covering resistances, respectively. In floor cooling, similar results were obtained: with the lowest floor covering resistance the exergy consumption in the floor structure was 9.5 W while it increased by 46 % and 90% for the mid- and high floor covering resistances, respectively.

The results also show that the increased floor covering resistance has a similar effect on the heating and cooling plant (water-side of the radiant floor heating system) to an increase in heating or cooling load, although the space heating and cooling loads are in fact constant. In order to obtain the same space heating or cooling effect, higher electricity input is required to the heat pump, and 14% higher exergy input is necessary to the power plant for FH\_HiRes compared to FH\_LoRes, and 5% higher exergy input is necessary to the power plant for FC\_HiRes compared to FC\_LoRes.

It should be noted that in FC\_HiRes, the supply water temperature falls below the dew point temperature of 16.3°C when the indoor temperature is 26°C and the relative humidity is 55%. This will bring certain limitations regarding the application of floor cooling and on the system performance; the dehumidification of the air might become necessary and it might not be possible to use natural heat sinks (ground, lake- or sea-water, etc.).

The effects of floor covering resistance on the system performance are less pronounced for the cooling system than the heating system. This is mainly because the heat pump is operating in favorable conditions (temperatures of outdoor air and of the water leaving the evaporator), and the cooling output from the floor being significantly lower compared to the heating output.

## **5. Conclusion**

The effects of floor covering resistance on the whole system performance of a radiant floor heating and cooling performance were studied using a reversible air-to-water heat pump as a heat source and sink.

The floor covering resistance has significant effects on the performance of the floor heating and cooling system and on the whole system. Higher floor covering resistance hinders the performance of the whole system by changing the requirements on average water temperatures and decreasing the COP values. When comparing the cases with the lowest and highest floor covering resistances, the exergy consumption in the floor structure almost doubles.

In order to obtain the same space heating and cooling effects, higher electricity input is required to the heat pump. For heating and cooling cases 14% and 5% larger exergy input was necessary to the power plant where the electricity is generated, respectively. The effects of floor covering resistance on the system performance were less pronounced for floor cooling than floor heating.

Increased floor covering resistance has a similar effect to an increased space heating or cooling load, on the water side of the radiant system. This will influence the dimensioning and operation of the heating or cooling plant, resulting in larger heating



and cooling plants than necessary if the floor covering resistance was kept to a minimum.

The same effect can also influence the choice of the heating and cooling plant by limiting the choices of heat sources and sinks: if the required supply temperatures are too high in heating mode or too low in cooling mode, the use of natural heat sources and sinks, to be found in our immediate surroundings, will not be possible.

In order not to hinder the performance of a radiant system and to fully benefit from the advantages of low temperature heating and high temperature cooling possibility, the covering resistance should be kept to a minimum through careful selection of materials and thicknesses, provided that structural and maintenance (e.g. wear and tear) concerns can be met and that the occupants are aesthetically satisfied.

### **Acknowledgment**

This study was financially supported by the Danish Energy Association's Research and Development Program (ELFORSK), project no. 344-060, "Sustainable plus-energy houses". The financial supports from DANVAK (Danish HVAC Society), Otto Mønstedts Fond, and Augustinus Fonden for an external research stay at Tokyo City University are gratefully acknowledged.

### **References**

- [1] B. Olesen, „Radiant Floor Cooling Systems,“ *ASHRAE Journal*, pp. 16-22, 2008.
- [2] K.-N. Rhee and K. W. Kim, „A 50 year review of basic and applied research in radiant heating and cooling systems for the built environment,“ *Building and Environment*, pp. 166-190, 2015.
- [3] P. Simmonds, N. Triana, J. Gautrey and R. Zhu, „The Influence on Surface Coverings on the Performance of Radiant Floors for both Heating and Cooling,“ in *ASHRAE Papers CD: 2014ASHRAE Winter Conference*, Atlanta, 2014.
- [4] Y. Chen and A. K. Athienitis, „A three-dimensional numerical investigation of the effect of cover materials on heat transfer in floor heating systems,“ *ASHRAE Transactions*, vol. 104, vol. 2, p. 1350, 1998.
- [5] S. Sattari and B. Farhanieh, „A parametric study on radiant floor heating system performance,“ *Renewable Energy*, pp. 1617-1626, 2006.
- [6] O. B. Kazanci, M. Shukuya and B. W. Olesen, „Exergy performance of different space heating systems: A theoretical study,“ *Building and Environment*, 99, 119-129, 2016. doi: 10.1016/j.buildenv.2016.01.025
- [7] O. B. Kazanci and B. W. Olesen, „Sustainable Plus-energy Houses: Final Report,“ Technical University of Denmark, Department of Civil Engineering, Kgs. Lyngby, 2014.
- [8] EN 1264-2, „Water based surface embedded heating and cooling systems - Part 2: Floor heating: Prove methods for determination of the thermal output using calculation and test methods,“ European Committee for Standardization, Brussels, 2008.
- [9] EN 1264-3, „Water based surface embedded heating and cooling systems - Part 3: Dimensioning,“ European Committee for Standardization, Brussels, 2009.
- [10] EN 1264-5, „Water based surface embedded heating and cooling systems - Part 5: Heating and cooling surfaces embedded in floors, ceilings and walls - Determination of the thermal output,“ European

Committee for Standardization, Brussels, 2008.

- [11] J. Babiak, B. W. Olesen and D. Petráš, Low temperature heating and high temperature cooling, Brussels: REHVA - Federation of European Heating, Ventilation and Air Conditioning Associations, 2009.
- [12] O. B. Kazanci, M. Shukuya and B. W. Olesen, „Theoretical analysis of the performance of different cooling strategies with the concept of cool exergy,“ *Building and Environment*, 100, 102-113, 2016. doi: 10.1016/j.buildenv.2016.02.013
- [13] M. Shukuya, *Exergy - Theory and Applications in the Built Environment*, New York: Springer, 2013.
- [14] M. Shukuya, „Energy, entropy, exergy and space heating systems,“ in *Healthy Buildings '94, Proceedings of the 3rd International Conference*, Budapest, 1994.