

Technical University of Denmark



## Techno-economic optimisation of three gas liquefaction processes for small-scale applications

**Nguyen, Tuong-Van; Rothuizen, Erasmus Damgaard; Elmegaard, Brian; H. Bruun, Allan**

*Published in:*

Proceedings of ECOS 2016: 29th International Conference on Efficiency, Cost, Optimization, Simulation and Environmental Impact of Energy Systems

*Publication date:*  
2016

*Document Version*  
Peer reviewed version

[Link back to DTU Orbit](#)

*Citation (APA):*

Nguyen, T-V., Rothuizen, E. D., Elmegaard, B., & H. Bruun, A. (2016). Techno-economic optimisation of three gas liquefaction processes for small-scale applications. In Proceedings of ECOS 2016: 29th International Conference on Efficiency, Cost, Optimization, Simulation and Environmental Impact of Energy Systems

## DTU Library

Technical Information Center of Denmark

---

### General rights

Copyright and moral rights for the publications made accessible in the public portal are retained by the authors and/or other copyright owners and it is a condition of accessing publications that users recognise and abide by the legal requirements associated with these rights.

- Users may download and print one copy of any publication from the public portal for the purpose of private study or research.
- You may not further distribute the material or use it for any profit-making activity or commercial gain
- You may freely distribute the URL identifying the publication in the public portal

If you believe that this document breaches copyright please contact us providing details, and we will remove access to the work immediately and investigate your claim.

# Techno-economic optimisation of three gas liquefaction processes for small-scale applications

*Tuong-Van Nguyen<sup>a,b,\*</sup>, Erasmus Damgaard Rothuizen<sup>a</sup>, Brian Elmegaard<sup>a</sup>, Allan H. Bruun<sup>c</sup>*

*<sup>a</sup>Section of Thermal Energy, Department of Mechanical Engineering, Technical University of Denmark, Nils Koppels Allé, 2800 Kongens Lyngby, Denmark*

*<sup>b</sup>Laboratory of Environmental and Thermal Engineering, Polytechnic School – University of São Paulo, Av. Prof. Luciano Gualberto, 05508-900 São Paulo, Brazil*

*<sup>c</sup>Kosan Crisplant A/S, P.O. Pedersens Vej 22, 8200 Århus, Denmark*

*\*Corresponding author: [tungu@mek.dtu.dk](mailto:tungu@mek.dtu.dk)*

## Abstract:

Natural gas liquefaction systems are based on refrigeration cycles, which can be subdivided into: the cascade, mixed refrigerant and expansion-based processes. They differ by their design configurations, components and working fluids, and thus have various operating conditions and equipment inventory. The present work investigates three configurations (single-mixed refrigerant, single and dual reverse Brayton cycles) for small-scale applications, which are optimised and evaluated individually. The influences of the refrigerant properties and process technologies are analysed, and the most promising cycle setups are identified. The findings illustrate the resulting trade-offs between the system performance and investment costs, which differ significantly with the type of refrigeration cycle. Although these configurations are suitable for small-scale applications, mixed-refrigerant processes prove to be more efficient (1000-2000 kJ/kg<sub>LNG</sub>) than expansion-based ones (2500-5000 kJ/kg<sub>LNG</sub>) over larger ranges of operating conditions, at the expense of a greater system complexity and higher thermal conductance (250-500 kW/K against 80-160 kW/K). The results show that the use of different thermodynamic models leads to relative deviations of up to 1% for the power consumption and 20% for the network conductance. Particular caution should thus be exercised when extrapolating the results of process models to the design of actual gas liquefaction systems.

## Keywords:

Gas liquefaction, small-scale applications, techno-economic analysis, multi-objective optimisation.

## 1. Introduction

Liquefied natural gas (LNG) is a liquid mixture of hydrocarbons consisting mainly of methane, and which is generally produced and stored at about -160°C. The use of LNG for storage and long-distance transportation from the gas production sites has been comprehensively studied and applied in the oil and gas sector. LNG is a cleaner fuel than conventional fossil fuels as it results in smaller emissions of nitrogen and sulphur oxides. The production of LNG has grown significantly in the last decades, and the installed capacity of the production facilities exceeds 320 mtpa (million tonnes per annum) worldwide, of which around 6% corresponds to small-scale facilities, i.e. with a capacity lower than 1 mtpa per unit [1]. The development of small-scale plants has gained interest in the last decades, because of the possible environmental, geopolitical and economic benefits. Some of the main issues of small-scale LNG facilities are: (i) the higher production cost per unit of LNG, (ii) the global profitability of the supply chain, (iii) the limitations in terms of system design. Furthermore, the scientific literature on small-scale LNG systems is less developed than for large-capacity liquefaction plants. Barclay and Denton [2] compare mixed refrigerant and expander-based processes for offshore applications, aiming at listing selection criteria. Their work suggests that expander-based processes are well-suited because of their compactness and high inherent safety. It also pinpoints the low performance of such cycles compared to high state-of-the-art, but does not

include a thorough analysis of the space requirements and cost performances. Finn [3] compares mixed-refrigerant and expansion-based processes for small-scale applications and concludes that (i) the former can be cost-effective if plate-fin exchangers and single compressors are used, and (ii) such cycles can compete with expander cycles for such sizes. Cao et al. [4] evaluate the performance of two types of small-scale LNG processes in skid-mounted packages, and concludes that a nitrogen-methane cycle can be superior to a single mixed-refrigerant process in the absence of propane pre-cooling. Remelje and Hoadley [5] analyse the performance of four refrigeration cycles for small-scale applications, of which three belong to the expander-based category. They state that the mixed-refrigerant process displays the smallest power consumption per unit of LNG produced, and that open-loop expansion processes are highly sensitive to the feed gas composition. Pérez and Díez [6] present the current situation of small to medium-scale LNG facilities, and discuss the technical factors that impact the selection of the refrigeration process. They propose qualitative parameters to help decision-makers. Castillo and Dorao [7] analyse the cost formation for expander and mixed-refrigerant technologies, with a focus on the heat transfer area costs. He and Ju [8] analyse sixteen configurations of expansion cycles for distributed-scale systems from a thermodynamic point of view and optimise these setups based on their second-law efficiency. Chang et al. [9] suggest the use of a Claude cycle, i.e. a process that combines expansion- and mixed-refrigerant processes to improve the performance and stability of the LNG system. In general, the optimisation procedures include a constraint based on the minimum temperature difference which can be allowed in the heat exchanger. This approach is nevertheless criticised in the work of Austbø and Gundersen [10], where it is stated that this constraint does not account for the distribution of driving forces with respect to the temperature profiles.

The literature survey shows that there is no clear agreement on the most suitable liquefaction process for small-scale applications. However, it is generally accepted that cascade and complex mixed-refrigerant processes such as the propane precooled mixed refrigerant process are not adequate. The following processes have attracted most attention – the single-mixed (SMR) and dual-mixed (DMR) refrigerant processes, as well as the nitrogen- and dual-expander systems. The abovementioned studies focus mainly on the technical performance of these processes for given design conditions, and discuss briefly their economic aspects, and no economic or multi-objective optimisations are actually conducted. Optimisation of large-scale liquefaction systems has been of interest in the last years, as shown with the annotated bibliography of Austbø et al. [11]. However, most of these works deal with a single objective function, such as the minimisation of the power consumption, capital costs, operational expenses, or the maximisation of the net profit. Few actually discuss the trade-off between the cycle efficiency and the resulting capital and operating costs. For example, Boulougoukis and Papanikolaou [12] optimise the design of a LNG terminal with focus on the motion response and sea surface evaluation. Shah et al. [13] present a multi-objective optimisation approach of a two-stage reverse Brayton cycle. Castillo and Dorao [14] deal with the case of a single-mixed refrigerant process and emphasise the importance of the market prices (gas and electricity) on the quality of the optimisation solutions.

Few studies compare several cycles by conducting multi-objective optimisation routines, analysing the trade-off of e.g. the network conductance and power consumption. They do not show the trade-off between the thermodynamic and economic performance, and even fewer studies focus on small-scale applications. The present work aims at addressing these gaps: it focuses on the optimisation of three small-scale gas liquefaction processes which differ by their design configuration and equipment count. The trade-offs between the technical and economic performances are assessed by conducting multi-optimisation routines, based on a systematic approach to compare the LNG processes in a consistent way. This paper is structured into five main sections, with the introduction being the first. Section 2 goes through a description of the process and economic models, section 3 presents the main findings for the three cycles under study, and section 4 elaborates on the practical implications of this work and on its limitations. Section 5 concludes this study and opens possibilities for future work.

## 2. Methodology

### 2.1. System description

The requirements for small- and large-scale LNG plants are different: the performance (power consumption) of the gas liquefaction process is of key importance for the latter, while other factors such as the equipment count, dynamic behaviour and compactness are of bigger importance for the former. For example, processes such as the propane precooled mixed refrigerant system (C3MR) and the pure-refrigerant cascade with nine or ten pressure levels are preferred for large-scale applications because of their high efficiency, but they are *not* suitable for small-scale because of their high equipment count and capital cost. The processes investigated in this work are the following: the single mixed-refrigerant (SMR) (Figure 1), the single- (Figure 2) and the dual-expander (Figure 3) systems. The first one belongs to the category of mixed-refrigerant processes, in which a mixture of hydrocarbons (e.g. methane, ethane, ethylene, propane, butanes, pentanes) and nitrogen is used as a refrigerant, and the cooling effect is generated by the Joule-Thomson effect (adiabatic expansion through a valve device).

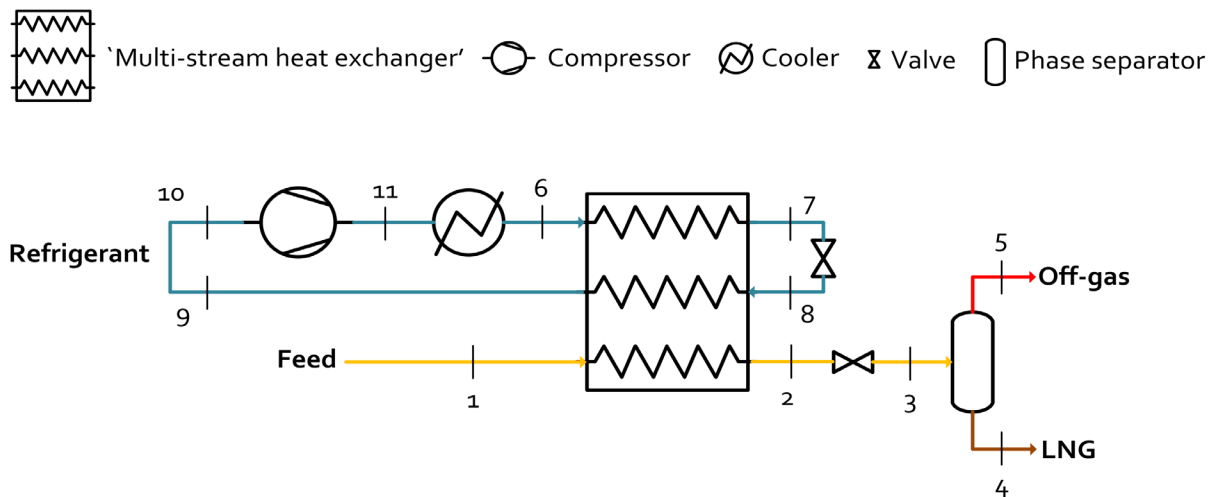

Fig. 1. Process flow diagram of the single mixed-refrigerant process (SMR).

The latter belong to the class of expansion-based processes, in which one (single) or two (dual) fluids act as refrigerant. The main concept is the use of a reverse Brayton cycle, and the cooling effect is obtained by vapour expansion through an expander in which work is extracted, and heat is rejected to the environment in intercooling and aftercooling steps. The working fluid is only in vapour phase throughout the complete cycle, which results in larger flows than in the mixed refrigerant process, as only sensible heat can be exploited.

In general, the working fluid is a pure component (nitrogen or methane) but may be a mixture of these two. The advantage of the mixed-refrigerant process is the improved match of the temperature profiles on the hot and cold sides, as the natural gas and refrigerant are zeotropic mixtures, and they respectively condense and evaporate over a range of temperatures. This results in a higher system efficiency and flexibility, since the refrigerant composition can be tuned to thermally match different feed compositions. The advantage of the expansion-based process is the system simplicity, and that the refrigerant is in gaseous phase, which avoids instabilities and maldistribution issues in the heat exchangers, a contrario to the two-phase behaviour of the mixed refrigerants. Few equipment items are required, and the system may be inherently safe if inert refrigerants, such as nitrogen, are used.

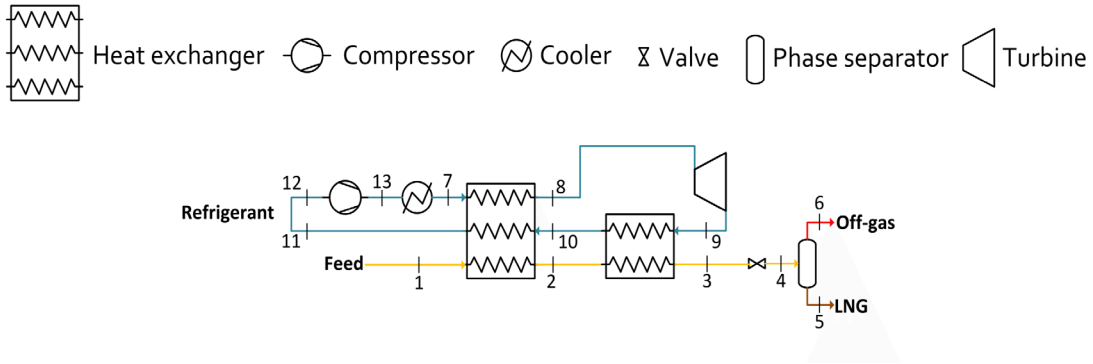

Fig. 2. Process flow diagram of the single reverse Brayton process.

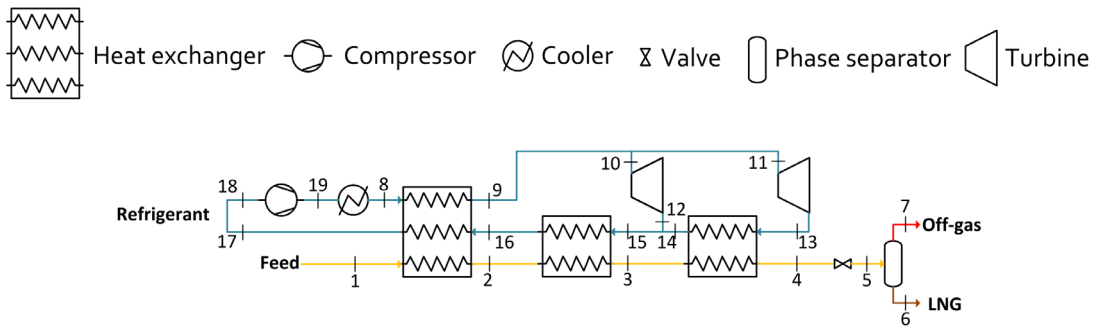

Fig. 3. Process flow diagram of the dual reverse Brayton process.

## 2.2. System modelling

The process models are developed in Aspen Plus version 7.2 using the Peng-Robinson equation of state (EOS) [15], which is a thermodynamic model widely used in the oil and gas industry for simulating hydrocarbon processes in which few (if any) polar compounds are present. The selection of other thermodynamic models such as the Redlich-Kwong [16] with Soave modifications [17] EOS, or the multi-parameter GERG [18] EOS, is discussed later.

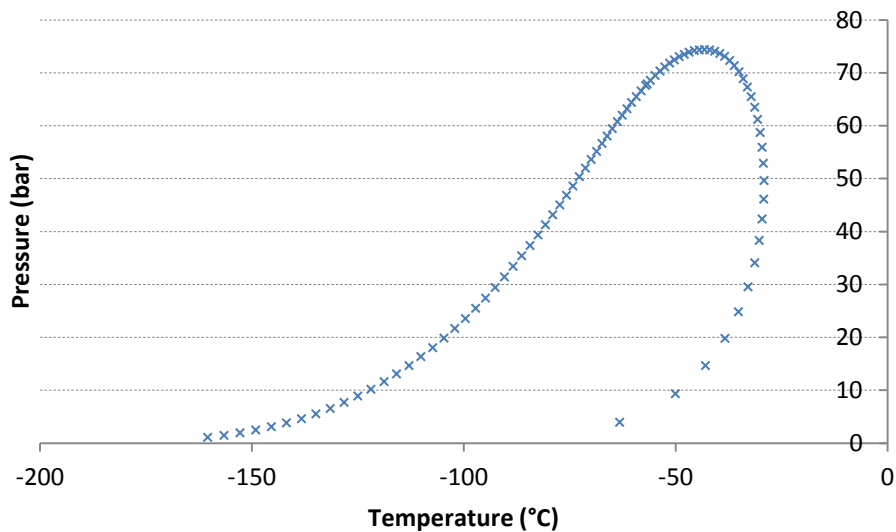

Fig. 4. Temperature-pressure phase envelope of the natural gas stream.

The process models build on the following assumptions:

- the system is assumed in steady-state conditions.
- the natural gas feed has an initial temperature and pressure of 15°C and 32 bar.
- the average composition is, on a molar basis, of 90.3% methane, 6.02% ethane, 2.43% propane, 0.37% *i*-butane, 0.57% *n*-butane and 0.31% nitrogen.
- the produced LNG has a temperature of -160°C after subcooling and is delivered at 1.7 bar.
- the recovered off-gas after subcooling and expansion is not re-liquefied and has a negligible flow rate (less than 0.1% of the feed gas flow) compared to the produced LNG.
- heat losses and pressure drops inside the heat exchangers are neglected.
- the compressors have a polytropic efficiency of 72%.
- intercooling to a temperature of 20°C within the compression process can be achieved.
- the turbines have an isentropic efficiency of 80%.
- in the case of the dual cycle, the temperatures at the outlets of each heat exchanger are fixed to the dew point, bubble point and subcooled temperatures of the natural gas.
- cooling water is available at a temperature of 10°C.

### 2.3. System performance

The performance of an LNG production system can be evaluated based on technical, economic and environmental indicators, and the present work focuses on the two first categories. The thermodynamic performance can be evaluated based on:

- the specific power consumption per unit of liquefied natural gas, which is expressed as:

$$w = \frac{\dot{W}}{\dot{m}_{LNG}}$$

- the coefficient of performance (cooling) of the refrigeration cycle, which is defined as the ratio of the cooling capacity by the net power consumption:

$$COP_C = \frac{\dot{Q}_C}{\dot{W}}$$

- the second-law efficiency of the LNG process is also called ‘figure of merit’: it relates the minimum theoretical power consumed to produce the cooling capacity to the actual one.

$$FOM = \frac{\dot{W}_{min}}{\dot{W}}$$

The first two indicators can be deduced from the energy balance of the overall system, while the third one is a direct application of the second law of thermodynamics, which states that real processes are non-ideal (irreversible) in essence. The economic performance can be assessed by calculating the capital and operating costs, and the former are derived applying the costing approach of Turton et al. [19], which have an uncertainty of +/- 30%. The purchased costs  $C_{pc}$  are calculated for each individual component using capacity-based correlations in the form of:

$$\log C_{pc} = k_1 + k_2 \log A + k_3 (\log A)^2$$

where  $k_1$ ,  $k_2$ , and  $k_3$  are correlation constants specific to each type of equipment item (e.g. plate heat exchanger, centrifugal compressor, etc.) and  $A$  is the associated capacity parameter (e.g. heat transfer area for a heat exchanger, power consumption for a compressor, etc.). These costs are adjusted to bare module costs by accounting for material and pressure factors, and actualised considering the inflation up-to-now by updating cost indexes. The total grassroot costs are finally deduced by summing the costs per component and adding the expenses related to the site installation and contingency factors.

The reader is referred to the handbook of Turton et al. [19] for further details on the numerical values of such correlations and a more thorough explanation of the costing approach. The investment period is taken to be 25 years with a discount rate of 10%, based on the assumptions of Stuer-Lauridsen et al. [20]. The plant availability is assumed to be 90%.

## 2.4. System optimisation

The system is optimised with the following objectives:

- maximising the system performance.
- minimising the system size, and this is correlated to the size of the heat exchanger.
- minimising the capital costs (CAPEX).

It can be seen that these objective functions are conflicting: for example, higher cycle efficiency and smaller operating costs (OPEX) can be achieved by minimising the temperature difference between the hot and cold sides in the LNG/refrigerant heat exchanger. However, the required heat transfer area ( $A$ ) and the conductance of the overall heat exchanger network ( $UA$ ) will increase consequently, which may in turn result in greater capital costs (CAPEX) depending on the required size of the compressor. These trade-offs are of particular interest for this study and are analysed by conducting a multi-objective optimisation. The results are shown as Pareto frontiers [21], where any improvement in one objective results in deterioration of another one. The decision variables of the optimisation problem differ with the process under study (Table 1). They can be grouped into the cycle parameters (e.g. temperature and pressure levels) and fluid properties (e.g. chemical composition).

Table 1. List of decision variables and bounds of the optimisation problem.

Parameter	Process	Lower bound	Upper bound
High-level pressure (bar)	SMR	10	50
	N <sub>2</sub>	40	120
	Dual N <sub>2</sub>	40	120
Low-level pressure (bar)	SMR	1	10
	N <sub>2</sub>	1	40
	Dual N <sub>2</sub>	1	40
Precooling temperature	N <sub>2</sub>	-40	-60
Methane flow rate (kmol/kg <sub>NG</sub> )	SMR	0.03	0.08
Ethane flow rate (kmol/kg <sub>NG</sub> )	SMR	0.03	0.08
Propane flow rate (kmol/kg <sub>NG</sub> )	SMR	0.00	0.05
<i>n</i> -Butane flow rate (kmol/kg <sub>NG</sub> )	SMR	0.00	0.02
<i>i</i> -Butane flow rate (kmol/kg <sub>NG</sub> )	SMR	0.00	0.02
<i>n</i> -Pentane flow rate (kmol/kg <sub>NG</sub> )	SMR	0.00	0.02
<i>i</i> -Pentane flow rate (kmol/kg <sub>NG</sub> )	SMR	0.00	0.02
Nitrogen flow rate (kmol/kg <sub>NG</sub> )	SMR	0.00	0.05
	N <sub>2</sub>	0.1	0.9
	Dual N <sub>2</sub>	0.1	0.9

The following constraints are considered in the optimisation procedure. For expansion-based cycles, the vapour fraction should exceed 92%, by analogy with steam turbines, to avoid droplet formation in the expansion process. The minimum temperature difference within the heat exchangers should exceed 3 K to ensure heat transfer. LNG systems, especially the ones using mixtures, are thermodynamically complex and there may be numerous interactions between the refrigeration cycles (case of dual processes). The optimisation problem displays therefore severe non-linearities and may present several local optima. Several works use evolutionary algorithms such as genetic ones, and the algorithm developed by Molyneaux [22] is used in the present work. Other techniques such as gradient-based techniques can be powerful for optimising SMR processes, as shown in Wahl et al. [23].

## 3. Results

### 3.1. Power minimisation

A comparison of studied processes, based on a single-objective optimisation, shows that mixed-refrigerant processes display smaller net power consumption, which is in the range of 1500-1800 kJ/kg<sub>LNG</sub>, while it exceeds 3000 kJ/kg<sub>LNG</sub> in the expansion-based cases. These numbers can be put in perspective with the energy content of the produced LNG, which is 49.2 MJ/kg (LHV basis) and 52.7 MJ/m<sup>3</sup> (Wobbe index) at 15°C and 1.013 bar. They are therefore equivalent to a power consumption of 0.5 kWh/kg<sub>LNG</sub> and 0.9 kWh/kg<sub>LNG</sub>, and they represent 3.5% and 6.5% of the LNG energy content, on a lower heating value basis, which corresponds to the figures given in the literature, although for different LNG compositions and input conditions.

#### *Single mixed-refrigerant process (SMR)*

A more thorough analysis of the SMR process (Figure 4) illustrates that the optimisation results can be divided into two categories:

- A ‘light mixed-refrigerant’, named case M1, characterised by high contents of nitrogen (about 14 mol-%) and methane (about 30 mol-%), and low contents of medium-weight hydrocarbons, i.e. ethane and propane (about 38 mol-%) and heavy hydrocarbons, i.e. butanes and pentanes (about 14 mol-%). The optimum high- and low-pressure levels are about 33 and 4 bar.
- An ‘heavy mixed-refrigerant’, named case M2, characterised by low contents of nitrogen (about 7 mol-%) and methane (about 21 mol-%), and high contents of medium-weight hydrocarbons (about 51 mol-%) and heavy hydrocarbons (about 19 mol-%). The optimum high- and low-pressure levels are about 14 and 1.5 bar.

The power consumptions associated with these optimum compositions and operating levels are in the same magnitude with a relative difference of (+/- 1.7%), the coefficient of performance is about 0.85, while the corresponding figure of merit is about 33%.

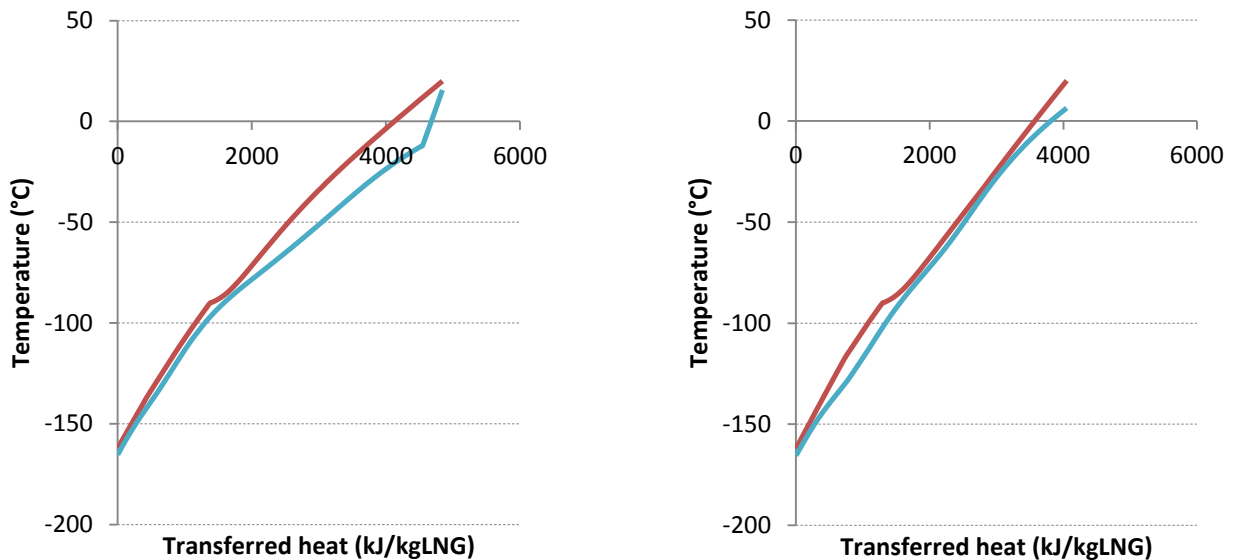

*Fig. 5. Comparison of the temperature-heat profiles (composite curves) for an optimised SMR process with different refrigerant compositions (M1, left and M2, right). The red and blue curves correspond to the hot and cold composite curves, respectively, or, in other words, the aggregated temperature-heat profile).*

The comparison of the temperature-heat profiles for these two optimum cases illustrates significant differences in the heat transfer process. Although the power consumption is similar and the same



constraints apply, the amount of heat transferred in the first case is higher by app. 800 kJ/kg<sub>LNG</sub>, i.e. a relative increase of 20%. The M1 case is characterised by a better match of the hot and cold sides in the subcooling part, which is explained by the greater content of light gases. The opposite trend is observed for the M2 case, with a better match in the precooling region and over the whole process. A comparison of the conductances of the heat exchanger shows that the first case displays a smaller UA value, of about 600 kW/K compared to 700 kW/K, which suggests that a larger heat exchanger is required in the second case. The conductances of the water coolers (intercooler and aftercooler) are negligible in comparison, which is due to the larger temperature difference between the hot refrigerant and cold water sides.

### Reverse single and dual Brayton cycles

The analysis of the reverse Brayton cycle based on nitrogen (Figure 5) shows that the minimum power consumption is around 3300 kJ/kg<sub>LNG</sub>, and it is found for two sets of values:

- High and low-pressure levels of app. 65 and 3 bar, with a precooling temperature of about -48°C;
- High and low-pressure levels of app. 95 and 6 bar, with a precooling temperature of about -55°C.

The coefficient of performance is about 0.46; while the corresponding figure of merit reaches 15%. These numbers are significantly lower than for the single mixed-refrigerant process. The differences in terms of power consumption are within (+/- 1.5%) but the conductance of the liquefaction heat exchangers is higher by about 25% in the first case, of 70 kW/K against 90 kW/K. In the case of stringent space limitations, a thorough analysis of the space required by each solution should be conducted, since designs with moderate high-pressure levels (65 bar) are characterised by smaller compressors, but larger heat exchangers.

In the case of the dual reverse Brayton cycle using nitrogen as refrigerant, all the optimised solutions display similar flow rates, of about 0.25 kmol<sub>N2</sub>/kg<sub>LNG</sub>. However, the low- and high-pressure levels vary in the range of 2-3 bar and either around 80 or 95 bar. Compared to the simpler configuration, the required pressure levels are generally higher, and the conductance of the heat exchangers is in the same magnitude, about 80 kW/K. The comparison of the temperature-heat profiles shows the smaller amount of heat transferred in the dual case, which is caused by the different refrigerant rates in the precooling and liquefaction heat exchangers.

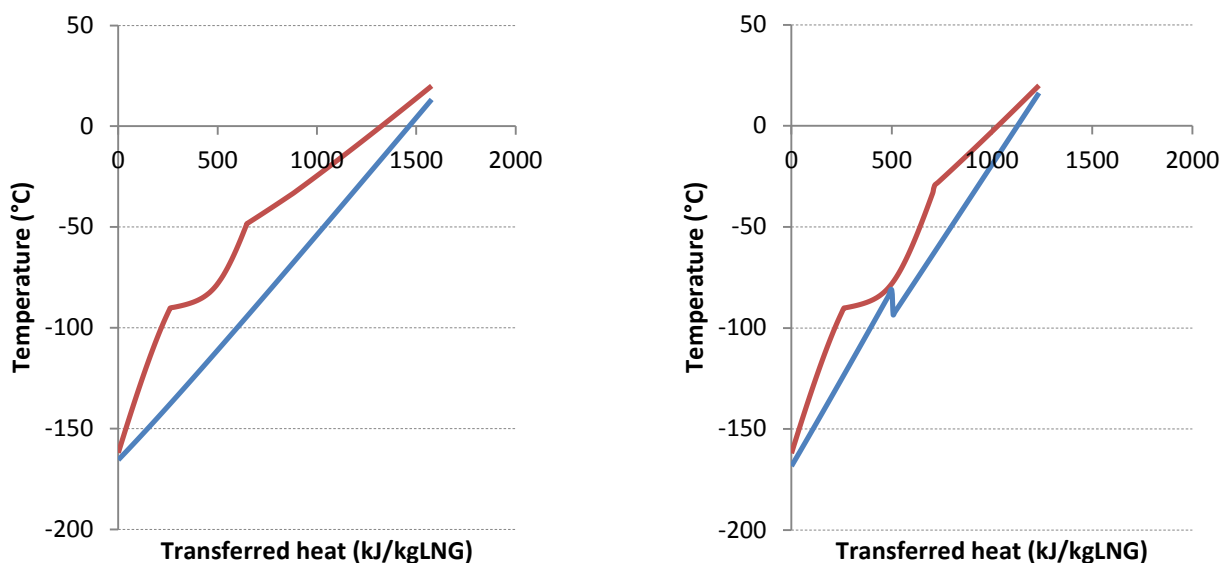

Fig. 6. Comparison of the temperature-heat profiles for optimised single (left) and dual (right) expansion-based processes using nitrogen (the red and blue curves correspond to the hot and cold composite curves, respectively, or, in other words, the aggregated temperature-heat profiles).

Compared to mixed-refrigerant processes, the fewer degrees of freedom seem to result in lower flexibility in the system design, which is translated in practice by a smaller range of optimised values. Substituting nitrogen by methane in the reverse Brayton process results in higher system performance. The power consumption decreases by about 7% for both single and dual configurations. It also leads to a smaller flow rate in the refrigeration circuit, because of the higher specific heat capacity of gaseous methane, compared to gaseous nitrogen. However, a main issue that is encountered with methane is the sub-atmospheric conditions in the subcooling stage of the liquefaction process, which is generally not be advisable because of the possible leakage issues. This issue can be circumvented if (i) higher subcooling temperatures are desired for the liquefied gas (for example, if the desired temperature is  $-150^{\circ}\text{C}$  instead of  $-160^{\circ}\text{C}$ , methane can be processed from  $-163^{\circ}\text{C}$ , which corresponds to a vapour pressure of 1.6 bar), (ii) methane is used in a topping cycle and nitrogen in a bottoming one.

### 3.2. Technical and economic trade-offs

#### *Trade-off between power consumption and conductance*

A comparison of the gas liquefaction processes based on the minimisation of the net power consumption suggests that mixed-refrigerant processes are preferable against expansion-based ones for small-scale liquefaction purposes. However, this single-objective approach used until now does not consider other important factors such as the process size and the associated capital costs. A multi-objective approach was therefore carried out to pinpoint the trade-off between different performance aspects. The Pareto frontiers (Figure 6) illustrate that the single-mixed refrigerant process presents two thresholds, a minimum power consumption of  $1200 \text{ kJ/kg}_{\text{LNG}}$  and a minimum conductance of the whole heat exchanger network of  $200 \text{ kW/K}$ , while these figures are of  $3000 \text{ kJ/kg}_{\text{LNG}}$  and  $75 \text{ kW/K}$  for the expansion-based processes investigated in this work.

◆ SMR    ▲ Dual (N<sub>2</sub>)    □ Reverse Brayton (N<sub>2</sub>)    × Dual (CH<sub>4</sub>)    + Reverse Brayton (CH<sub>4</sub>)

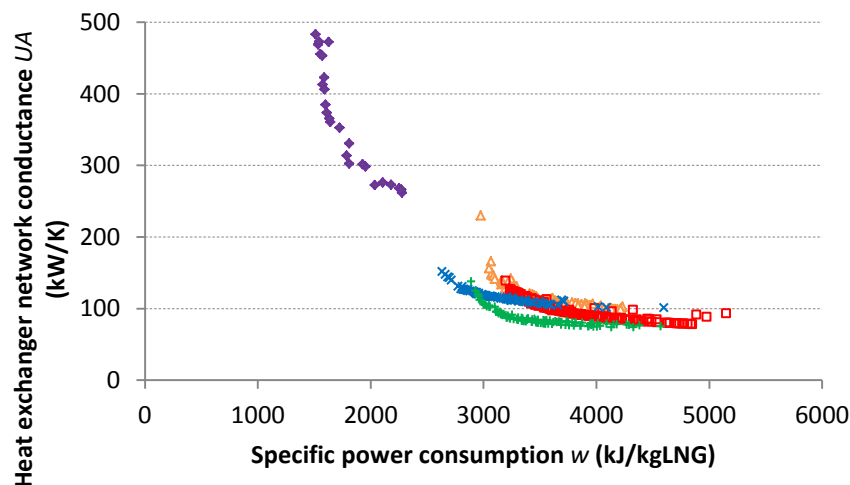

Fig. 7. Trade-offs between the specific power consumption and heat exchanger network conductance for each small-scale process.

In the case of the SMR process, the main differences between the solutions characterised by a minimum power consumption or by a minimum overall conductance differ mainly in the operating pressures ( $30 \text{ bar}$  against  $37 \text{ bar}$  for the high-level, and  $4$  against  $1$  for the low-level) and contents of medium-weight hydrocarbons ( $5\%$  against  $7\%$  for propane, and  $4\%$  against  $2\%$  for *n*-butane). The contents of methane, ethane and nitrogen vary in a range of ( $\pm 1\%$ ). When sorted by family of chemical compounds (light- and medium-weight alkanes, heavy hydrocarbons, nitrogen), no significant differences could be found between the several mixture compositions. For the single-stage expansion process, the main differences lie in the refrigerant flowrate, the low-pressure level

and the precooling temperature. Higher flowrates (0.3 kmol/kg<sub>LNG</sub> against 0.2 kmol/kg<sub>LNG</sub>), combined with a lower precooling temperature (-48°C against -12°C) and a moderate low-pressure level (around 7 bar against 1 bar) are associated with smaller power consumption. This illustrates that: (i) higher flowrates are required for lower expansion ratios to ensure enough heat transfer driving force in the multi-stream heat exchanger, (ii) lower precooling temperatures result in smaller net power consumption, at the expense of larger heat transfer areas. Similar flowrates (0.22 kmol/kg<sub>LNG</sub>) and high-pressure levels are found for all configurations, and the only difference is found for the low-pressure level. Compared to the conventional reverse Brayton cycle, the dual process is systematically featured by smaller flowrates of refrigerant. The use of methane instead of nitrogen is beneficial, as it results either in a reduction of the specific power consumption by up to 400 kJ/kg<sub>LNG</sub> or in a smaller conductance of the entire heat exchanger network by up to 50 kW/K.

### **Trade-off efficiency – capital costs**

The capital costs were estimated for a small-scale system producing about 28.4 kilotons per annum – and a multi-objective optimisation assessing the trade-off between the capital costs and specific power consumption was carried out. The findings (Figure 7) suggest that the single mixed-refrigerant process displays a smaller capital cost than expansion-based cycles, of about 50% in average. Conventional mixed-refrigerant processes do not use turbines and the pressure ratios over the compressors are smaller. However, these results should be taken with caution, because:

- the cost correlations used in this work display an uncertainty of (+/- 30%).
- mixed-refrigerant processes in oil and gas processing and large-scale liquefaction systems are based on multi-stream heat exchangers, such as of the spiral-wound type. This additional design complexity is not accounted for in the cost correlations.
- expansion-based cycles may use turboexpanders, and the costs would be lower than assuming a separate compressor and turbine.
- cost calculations based on the heat transfer area are common for conventional two-stream heat exchangers. They are more challenging to apply for cryogenic heat exchangers because of the higher number of streams, confidentiality of the costs of actual plants, and complex physical mechanisms in these components (e.g. maldistribution and axial heat transfer) [24].

However, the comparison of the single and dual Brayton cycles lies on the same assumptions, and the trends are therefore consistent. As expected, for the same performance, the dual cycle presents greater capital costs because of the additional complexity, but gives a reduction of 10% of the power consumption for the same system costs.

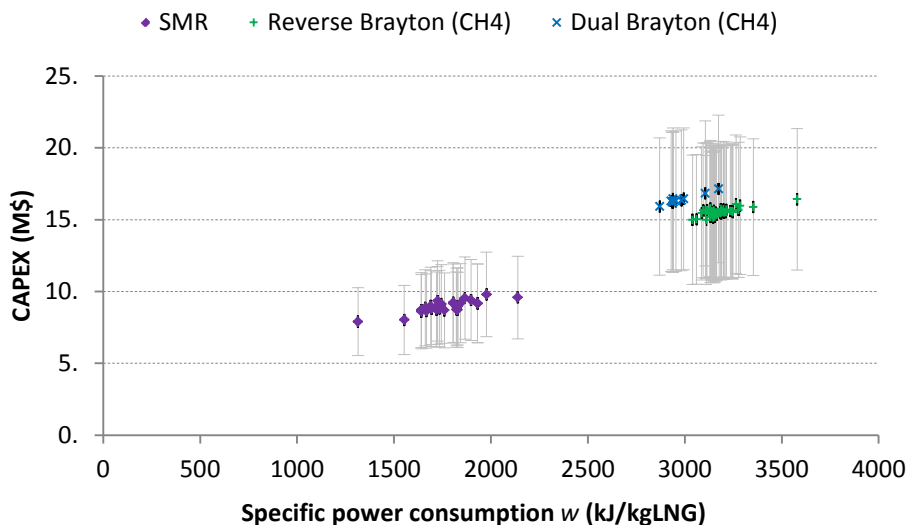

Fig. 8. Trade-offs between the specific power consumption and capital costs for each small-scale process.

### 3.3. Thermodynamic property models

The optimal configurations were simulated at first using the Peng-Robinson equation of state, which is a cubic equation of state well-suited for simulations of hydrocarbon processes. A literature survey shows that all optimisation studies of gas liquefaction processes were performed considering only one thermodynamic model. Only a few works, such as the one of Dauber and Span [25], discuss the impact of using different equations of state on the predictions of the power consumption and temperature conditions. The multi-parameter model of the 'Groupe Européen de Recherches Gazières' may be seen as the most accurate model, as it builds on fundamental derivations of the Helmholtz free energy and includes reference equations of state such as the models of Span and Wagner [26]. It is computationally-costly but returns results within the uncertainty range of measurements.

The other equations of state are therefore compared against that model and the relative differences are calculated. A comparison for the SMR process (Table 2) suggests that the PR EOS is generally more accurate in the prediction of the heat transfer rates ( $Q$ ) and conductance  $UA$ . The opposite conclusion can be drawn for the estimation of the temperature approach in the heat exchanger ( $\Delta T_{\min}$ ). This suggests that the prediction of the temperature profiles within the cryogenic heat exchangers is on overall more accurate with the cubic equation of Peng and Robinson.

*Table 2. Comparison of the GERG, PR and SRK models for the optimum cases of the single mixed-refrigerant process (numbers in parentheses correspond to the relative differences).*

	GERG	PR	SRK
$\dot{Q}$ (kW)	4770	4820 (1.0%)	4940 (3.5%)
UA (kW/K)	570	600 (4.6%)	680 (19.2%)
$\Delta T_{\min}$ (K)	2.2	3.2	2.2
$\dot{W}$ (kW)	1460	1440 (-0.8%)	1460 (0.1%)

These conclusions cannot be generalised for all gas liquefaction processes and refrigerant compositions. The same analysis, performed for expansion-based processes, suggests that the Peng-Robinson EOS is generally more accurate. However, the deviation in the prediction of the heat duty reaches up to 6% for the subcooling heat exchanger in the dual expansion system, but is only about 1.9% when considering the total amount of heat removed from 20°C to -162°C. This suggests that the Peng-Robinson equation of state presents deviations in the prediction of the dew and bubble points, and in the derivation of the specific heat capacity in the liquid phase, which is confirmed by numerous works in this field [25].

## 4. Discussion

### *Performance of the single mixed-refrigerant process (SMR)*

The results presented in the existing literature cannot be compared directly with the present findings. Different values of the temperature and pressure levels, allowable temperature differences, and maximum turbomachinery efficiencies are used. Remelje and Hoadley [5] performed a thermodynamic performance analysis of the SMR process as well as of other expansion systems, which are not presented in the present work. They find, for their optimum SMR case, a figure of merit of 36%, which is comparable to the 33% found in our results, and the difference can be imputed to the higher efficiencies of the compressors that they assume. Chang et al. [9] analyse an optimised and ideal SMR process (i.e. with a minimum temperature difference of 0 K in the heat exchangers and 100% efficiency of the compressors) for a similar gas composition and state that the maximum figure of merit for such cycles is about 57%. The simulation of the proposed optimal solutions, assuming an efficiency of 100% of the compressors, gives a figure of merit of about 51%.

This suggests that a further optimisation of the mixture composition assuming a minimum temperature approach of 0 K would return results in the same magnitude. The conclusions of the present work on the effects of varying the refrigerant composition (contents of methane, nitrogen, butanes and pentanes) are also supported by the works of Austbø [27], where it is claimed that the system performance, in the optimal cases, is mostly affected by the mixture content of light ends.

### ***Performance of the expansion-based processes (single and dual)***

As suggested in the literature [5, 9], expansion-based processes present higher power consumption than mixed-refrigerant processes, and this finding is supported in the present work in the case of small-scale applications. In consequence, these systems also present a lower coefficient of performance and second-law efficiency. A direct comparison with the work of Remelje and Hoadley [5] is not possible since they do not analyse a simple or dual reverse Brayton cycle, but most advanced configurations. However, they also conclude that mixed-refrigerant processes are generally more efficient. Chang et al. [9] also investigate the performance of an optimised reverse Brayton process and find an ideal limit (figure of merit) of 60%. These figures are, however, difficult to compare directly because of the dissimilarities of the assumptions. The simulation of the present solution, assuming an efficiency of 100% of the turbomachines, gives a figure of merit of about 49%. This indicates that further optimisation of the pressure levels, to achieve a minimum temperature approach of 0 K in all heat exchangers, would give results in the same magnitude.

### ***Overall conductance of the heat exchanger network***

No numerical figures have been found in the literature about the UA values of the heat exchanger network for mixed-refrigerant and expansion-based processes. Most remarks are qualitative, stating for example that the heat exchangers for mixed-refrigerant processes are bigger as a result of a closer temperature match over the entire liquefaction process, compared to expansion-based ones.

### ***Future work***

Future work within this topic will include performance comparisons for a higher number of mixed-refrigerant and expansion-based processes, from nitrogen to methane reverse Brayton cycles (open and closed) to dual mixed systems. Moreover, a more thorough comparison of the thermodynamic models used for simulating such systems would be beneficial. It is indeed shown that the use of cubic or fundamental equations of state potentially gives noticeable discrepancies, which may be important to consider in the light of the small temperature approaches that are found in LNG heat exchangers.

## **5. Conclusion**

This paper presents a comparison of three small-scale processes for the liquefaction of natural gas. The first one is the single mixed-refrigerant process, which builds on the use of up to 8 chemical compounds, whilst the two latter are the single and dual expansion-based cycles, using nitrogen or methane as pure refrigerant. Under the given set of assumptions and considering natural gas from the Danish grid after removal of carbon dioxide and heavy hydrocarbons, the SMR process is characterised by a power consumption of less than 1800 kJ/kg<sub>LNG</sub>, while this reaches more than 2600 kJ/kg<sub>LNG</sub> for the N<sub>2</sub> or CH<sub>4</sub> single-stage expansion processes. These numbers were estimated by conducting a single-objective optimisation. A further comparison was then performed by a multi-objective optimisation, considering the minimisation of the thermal conductance (UA), which illustrates the system size, and the system capital costs. Such an approach is beneficial for assessing technical, practical and economic trade-offs. The extension of this work to a larger group of system configurations can set up a basis for comparing more consistently gas liquefaction processes.

## Acknowledgments

This work is part of the Danish societal partnership Blue INNOship and is partly funded by the Innovation Fund Denmark under File No. 155-2014-10 and the Danish Maritime Fund.

## Nomenclature

$A$	heat transfer area, $m^2$ ; or capacity parameter
$C$	cost rate, \$
$\Delta T$	temperature approach, K
$\dot{Q}$	heat rate, W
$U$	overall heat transfer coefficient, $W/(m^2 K)$
$\dot{W}$	power consumption, W
$k$	cost correlation constants
$\dot{m}$	mass flow rate, kg/s
$w$	specific power consumption, kJ/kg

## Abbreviations

CAPEX	capital expenses
COP	coefficient of performance
EOS	equation of state
FOM	figure of merit
LNG	liquefied natural gas
OPEX	operational expenses
SMR	single mixed-refrigerant

## Subscripts and superscripts

min	minimum
pc	purchased cost

## References

- [1] International Gas Union, "World LNG report - 2014 edition," International Gas Union, Tech. Rep., 2014.
- [2] M. Barclay and N. Denton, "Selecting offshore lng processes," *LNG journal*, vol. 10, no. 1, pp. 34–36, 2005.
- [3] A. Finn, "Technology choices," Costain Oil, Gas & Process Ltd, Tech. Rep., 2006.
- [4] W.-s. Cao, X.-s. Lu, W.-s. Lin, and A.-z. Gu, "Parameter comparison of two small-scale natural gas liquefaction processes in skid-mounted packages," *Applied Thermal Engineering*, vol. 26, no. 8, pp. 898–904, 2006.
- [5] C. Remelje and A. Hoadley, "An exergy analysis of small-scale liquefied natural gas (lng) liquefaction processes," *Energy*, vol. 31, no. 12, pp. 2005–2019, 2006.
- [6] S. Pérez and R. Déz, "Opportunities of monetising natural gas reserves using small to medium scale lng technologies," in *IGU 24th world gas conference*, Repsol, Argentina, 2009.
- [7] L. Castillo and C. Dorao, "Influence of the plot area in an economical analysis for selecting small scale lng technologies for remote gas production," *Journal of Natural Gas Science and Engineering*, vol. 2, no. 6, pp. 302–309, 2010.
- [8] T. He and Y. Ju, "Performance improvement of nitrogen expansion liquefaction process for small-scale lng plant," *Cryogenics*, vol. 61, pp. 111–119, 2014.

- [9] H.-M. Chang, "A thermodynamic review of cryogenic refrigeration cycles for liquefaction of natural gas," *Cryogenics*, vol. 72, pp. 127–147, 2015.
- [10] B. Austbø and T. Gundersen, "Impact of Problem Formulation on LNG Process Optimization," *AIChE Journal*, 2016.
- [11] B. Austbø, S. W. Løvseth, and T. Gundersen, "Annotated bibliography—Use of optimization in LNG process design and operation," *Computers & Chemical Engineering*, vol. 71, pp. 391–414, 2014.
- [12] E. K. Boulougouris and A. D. Papanikolaou, "Multi-objective optimisation of a floating lng terminal," *Ocean engineering*, vol. 35, no. 8, pp. 787–811, 2008.
- [13] N. M. Shah, A. F. Hoadley, and G. Rangaiah, "Inherent safety analysis of a propane precooled gas-phase liquefied natural gas process," *Industrial & Engineering Chemistry Research*, vol. 48, no. 10, pp. 4917–4927, 2009.
- [14] L. Castillo and C. A. Dorao, "Consensual decision-making model based on game theory for lng processes," *Energy Conversion and Management*, vol. 64, pp. 387–396, 2012.
- [15] D.-Y. Peng and D. B. Robinson, "A New Two-Constant Equation of State," *Industrial & Engineering Chemistry Fundamentals*, vol. 15, no. 1, pp. 59–64, Feb. 1976.
- [16] O. Redlich and J. Kwong, "ON THE THERMODYNAMICS OF SOLUTIONS. V An Equation of State. Fugacities of Gaseous Solutions," *Chemical Reviews*, vol. 44, pp. 233–244, 1949.
- [17] G. Soave, "Equilibrium constants from a modified Redlich–Kwong equation of state," *Chemical Engineering Science*, vol. 27, no. 6, pp. 1197–1203, 1972.
- [18] O. Kunz and W. Wagner, "The gerg-2008 wide-range equation of state for natural gases and other mixtures: an expansion of gerg-2004," *Journal of chemical & engineering data*, vol. 57, no. 11, pp. 3032–3091, 2012.
- [19] R. Turton, R. Bailie, W. Whiting, J. Shaeiwitz, and D. Bhattacharyya, *Analysis, Synthesis and Design of Chemical Processes*, 4th ed., ser. Prentice Hall International Series in the Physical and Chemical Engineering Sciences. Prentice Hall, 2012.
- [20] F. Stuer-Lauridsen, J. B. Nielsen, T. Odgaard, M. Birkeland, C. W. Graugaard, L. P. Blikom, N. Muro-Suné, M. Andersen, and F. Øvlisen, "Natural gas for ship propulsion in Denmark – Possibilities for using LNG and CNG on ferry and cargo routes," LITEHAUZ, IncentivePartners, DNV, Rambøll Oil & Gas, Copenhagen, Denmark, Tech. Rep. Environmental Project No. 1338 2010, 2010.
- [21] C. Mattson and A. Messac, "Pareto Frontier Based Concept Selection under Uncertainty, with Visualization," *OPTE: Optimization and Engineering*, vol. 6, no. 1, pp. 85–115, 2005.
- [22] A. Molyneux, "A practical evolutionary method for the multi-objective optimisation of complex integrated energy systems including vehicle drivetrains," Ph.D. dissertation, École Polytechnique Fédérale de Lausanne, 2002.
- [23] P. E. Wahl, S. W. Løvseth, and M. J. Mølnvik, "Optimization of a simple lng process using sequential quadratic programming," *Computers & Chemical Engineering*, vol. 56, pp. 27–36, 2013.
- [24] G. Skaugen, M. Hammer, P. Wahl, and Ø. Wilhelmsen, "Constrained non-linear optimisation of a process for liquefaction of natural gas including a geometrical and thermo-hydraulic model of a compact heat exchanger," *Computers & Chemical Engineering*, vol. 73, pp. 102–115, 2015.
- [25] F. Dauber and R. Span, "Modelling liquefied-natural-gas processes using highly accurate property models," *Applied Energy*, vol. 97, pp. 822–827, 2012.
- [26] R. Span and W. Wagner, "Equations of state for technical applications. II. Results for nonpolar fluids," *International Journal of Thermophysics*, vol. 24, no. 1, pp. 41–109, 2003.
- [27] B. Austbø, "Use of Optimization in Evaluation and Design of Liquefaction Processes for Natural Gas," Ph.D. dissertation, NTNU, Norway, 2015.