

## Feasible Working Domains – Decision Support for Heat Pump Projects

Ommen, Torben Schmidt

*Publication date:*  
2015

*Document Version*  
Peer reviewed version

[Link back to DTU Orbit](#)

*Citation (APA):*

Ommen, T. S. (2015). Feasible Working Domains – Decision Support for Heat Pump Projects [Sound/Visual production (digital)]. 4th International Symposium on Advances in Refrigeration and Heat Pump Technology, Odense, Denmark, 19/11/2015

## DTU Library

Technical Information Center of Denmark

---

### General rights

Copyright and moral rights for the publications made accessible in the public portal are retained by the authors and/or other copyright owners and it is a condition of accessing publications that users recognise and abide by the legal requirements associated with these rights.

- Users may download and print one copy of any publication from the public portal for the purpose of private study or research.
- You may not further distribute the material or use it for any profit-making activity or commercial gain
- You may freely distribute the URL identifying the publication in the public portal

If you believe that this document breaches copyright please contact us providing details, and we will remove access to the work immediately and investigate your claim.

## Feasible Working Domains – Decision Support for Heat Pump Projects

4th International Symposium on Advances in Refrigeration and Heat Pump Technology

November 19<sup>th</sup> 2015

**Torben Ommen**

Section of Thermal Energy, Technical University of Denmark

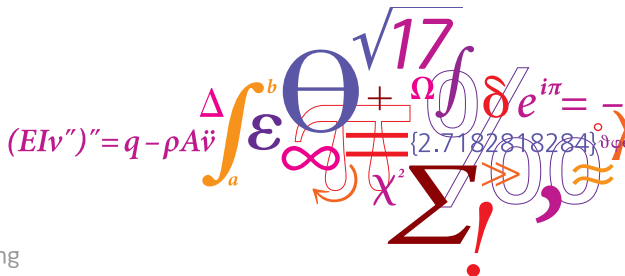

## Motivation

Potential for energy and economic optimisation in industrial plants and district heating systems by using large scale heat pumps.

- Complex systems: economic optimum depends on both heat pump performance, investment, expected operation hours, taxation and fuel cost.
- Pinch- or plant optimisation specialists are not necessarily experts on best available heat pump technology, and may thus be assisted by decision support tools.

## Motivation

Potential for energy and economic optimisation in industrial plants and district heating systems by using large scale heat pumps.

- Complex systems: economic optimum depends on both heat pump performance, investment, expected operation hours, taxation and fuel cost.
- Pinch- or plant optimisation specialists are not necessarily experts on best available heat pump technology, and may thus be assisted by decision support tools.

### Working domains

- Introduced in "Comparison of the working domains of some compression heat pumps and a compression-absorption heat pump" by Brunin et al. (1997)
  - Economic feasibility integrated by including two physical constraints
  - Technical constraints are similar to operating envelope for individual components
- Technical and economical working domains for single stage industrial heat pumps.
  - R134a, R290, R600a, R717-LP, R717-HP and R744 in Ommen et al. (2015a)
  - Ammonia-water hybrid absorption compression HP in Jensen et al. (2015)
  - R600a and R717-HP in series in Ommen et al. (2015b)

## Working domains in literature

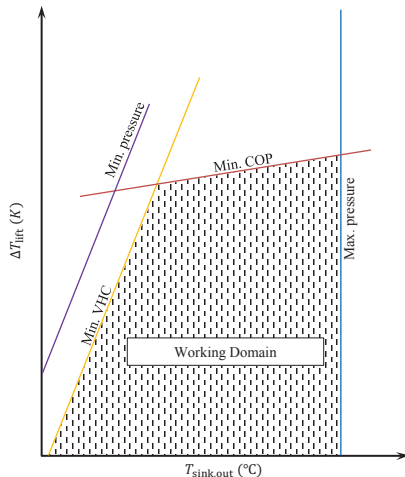

(a) Example of working domain with VHC and COP to represent economic feasibility (Brunin et al., 1997)

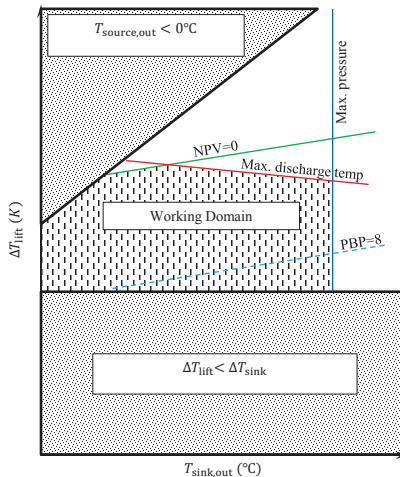

(b) Example of working domain with economic and technical constraints (Ommen et al., 2015a).

## Outline for Presentation

- **Introduction**
  - Motivation
  - Working domains in literature
- **Method**
  - Vapour compression heat pump
  - Economic assumptions
  - Heat exchanger design and calculation
  - Influence of key economic assumptions on NPV
- **Examples of working domains**
  - Single stage vapour compression HP
  - Ammonia-Water Hybrid Compression-Absorption HP
- **Vapour compression HPs in series**
  - Vapour compression HPs in series
  - COP and NPV
  - Comparison with working domain for single stage VCHP
- **Further steps**
  - A second economic case
  - Two stage VCHP configurations
- **Discussion**

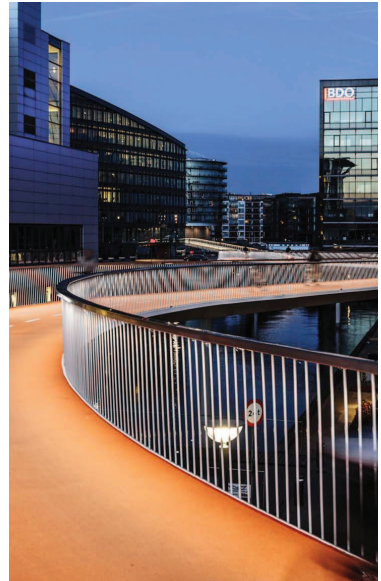

# Vapour compression heat pump

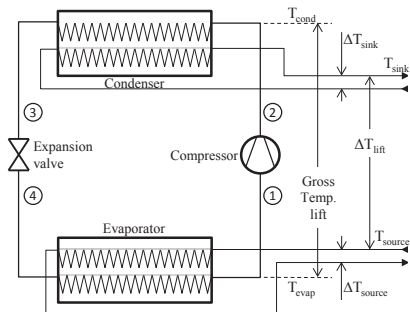

(a) Principle sketch of VCHP

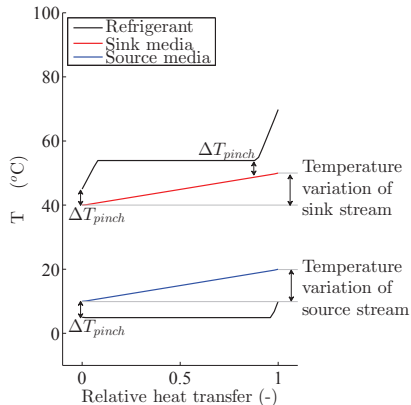

(b) Temperature - heat load diagram of VCHP

## Vapour compression heat pump in finite reservoirs

Typically used operational parameters for heat pump performance:

Type of data	Value	Unit	Designation
Efficiency	0.8	/	Compressor isentropic efficiency
	0.8	/	Compressor volumetric efficiency
	0.95	/	Electric motor efficiency
Temperature	5	K	Evaporator superheat
	5	K	Minimum pinch point in heat exchangers



## Economic assumptions

- Heat pump load: 1000 (kW)
- Operating time 3500 (h/year)
- Lifetime 15 (years)
- Natural gas burner efficiency 0.9 (-)
- Interest rate of 7 (%)
- Inflation rate of 2 (%)
- NPV and PBT based on gas boiler replacement
- Component investment cost based on Danish prices
- Danish electricity and gas prices were used
- Natural gas burner investment and O&M not considered

Correlations for component cost of the type:  $PEC_Y = PEC_W \left( \frac{X_Y}{X_W} \right)^\alpha$ :

Component	type	$PEC_W$ (€)	$X_W$	$\alpha$ (-)	Source
Compressor	R600a	19850	279.8 (m <sup>3</sup> h <sup>-1</sup> )	0.73	trade business <sup>1 2</sup>
	R717-HP	NDA	NDA	NDA	manufacturer <sup>4</sup>
Electrical motor	R600a	0	0	0	incl. in compressor <sup>1 2</sup>
	R717-HP	10710	250 (kW)	0.65	trade business <sup>1</sup>
Receiver	R600a	1444	0.089 (m <sup>3</sup> )	0.63	trade business <sup>1</sup>
	R717-HP	1934	0.089 (m <sup>3</sup> )	0.66	trade business <sup>1</sup>
Plate heat exchanger	R600a	15526	42 (m <sup>2</sup> )	0.8	trade business <sup>1 2 3</sup>
	R717-HP	NDA	NDA	NDA	manufacturer <sup>5</sup>

<sup>1</sup> (H. Jessen Jørgensen A/S (2013))

<sup>2</sup> (FK Teknik A/S (2013))

<sup>3</sup> (Ahlseil Danmark ApS (2013))

<sup>4</sup> (Johnson Controls, Inc. (2013))

<sup>5</sup> (SWEP International AB (2013))

## Heat exchanger design and calculation

- All HEX are plate type with chevron corrugation
- Commercial plate sizes were applied
- Mass and liquid/vapour maldistribution was neglected
- Counter flow arrangement
- Heat transfer and pressure drop correlations from literature was applied

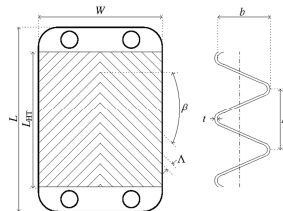

Component	Media	Zone	Heat transfer	Pressure drop
Condenser	H <sub>2</sub> O		Martin (1996)	Martin (1996)
Condenser	R <sub>xxx</sub>	vapour only:	Martin (1996)	Martin (1996)
		two-phase:	Yan et al. (1999)	Yan et al. (1999)
		transcritical:	Martin (1996)	Martin (1996)
		liquid only:	Martin (1996)	Martin (1996)
Evaporator	H <sub>2</sub> O		Martin (1996)	Martin (1996)
Evaporator	R <sub>xxx</sub>	two-phase:	Yan and Lin (1999)	Yan and Lin (1999)
		vapour only:	Martin (1996)	Martin (1996)

## Influence of key economic assumptions on NPV

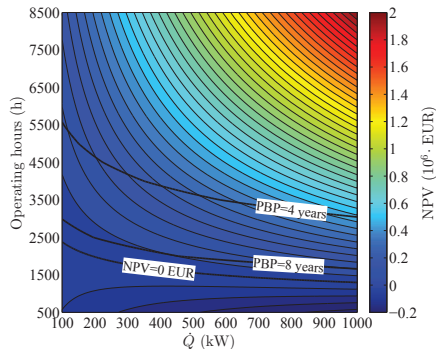

(a) NPV of HP system with variations in size and yearly operation hours

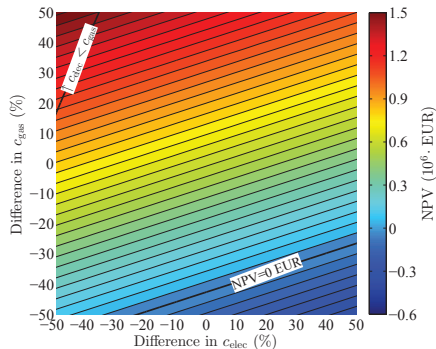

(b) NPV of HP system with variations in fuel cost

Figure: R717-HP heat pump operating at  $T_{\text{sink,out}} = 60^\circ\text{C}$ ,  $T_{\text{lift}} = 20^\circ\text{C}$ ,  $\Delta T_{\text{sink}}=20$  K,  $\Delta T_{\text{source}}=10$  K

## Outline for Presentation

- **Introduction**
  - Motivation
  - Working domains in literature
- **Method**
  - Vapour compression heat pump
  - Economic assumptions
  - Heat exchanger design and calculation
  - Influence of key economic assumptions on NPV
- **Examples of working domains**
  - Single stage vapour compression HP
  - Ammonia-Water Hybrid Compression-Absorption HP
- **Vapour compression HPs in series**
  - Vapour compression HPs in series
  - COP and NPV
  - Comparison with working domain for single stage VCHP
- **Further steps**
  - A second economic case
  - Two stage VCHP configurations
- **Discussion**



# Examples of working domains for single stage vapour compression HP

Four different sink and source temperature glides investigated

$$\Delta T_{\text{sink}} / \Delta T_{\text{source}}$$

10K/10K

20K/10K

20K/20K

40K/10K

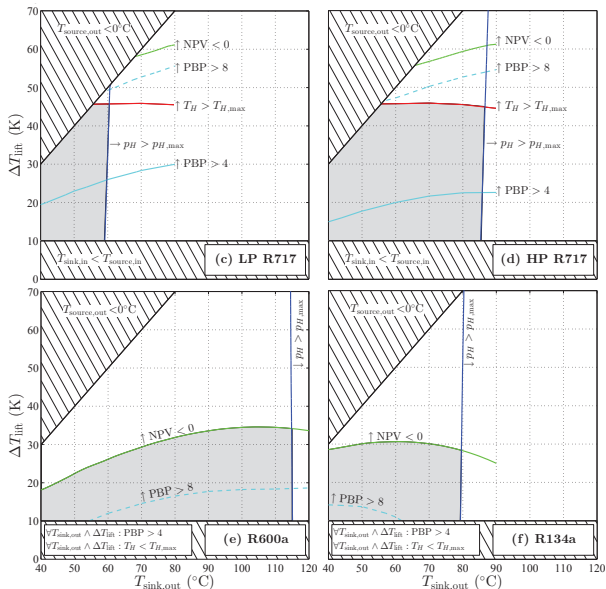

## Examples of working domains for single stage vapour compression HP

Four different sink and source temperature glides investigated

$$\Delta T_{\text{sink}} / \Delta T_{\text{source}}$$

10K/10K

20K/10K

20K/20K

40K/10K

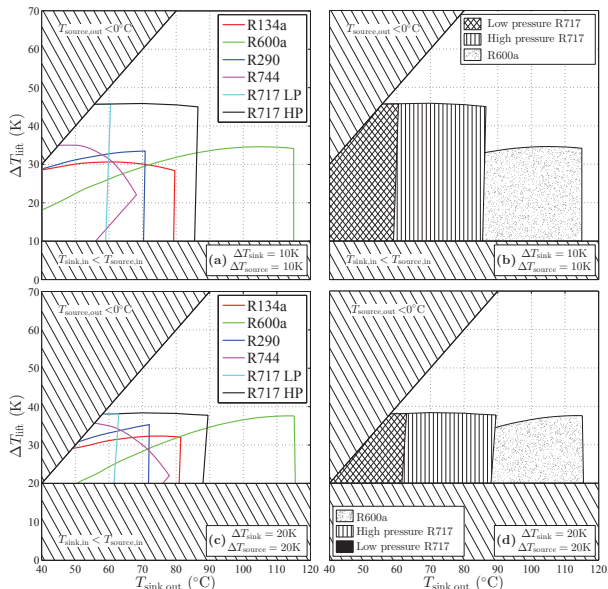

## Ammonia-Water Hybrid Compression-Absorption HP

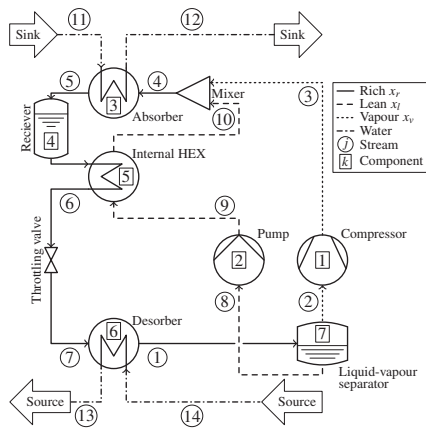

(a) Principle sketch of the HACHP

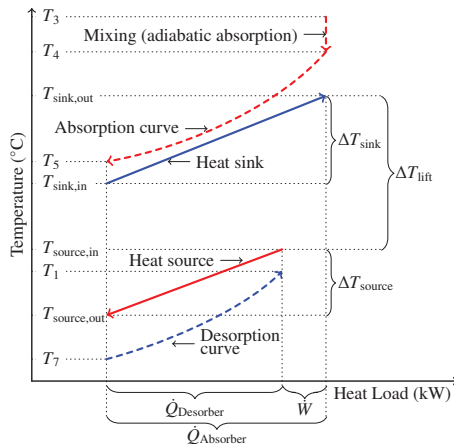

(b) Temperature - heat load diagram of the HACHP

# Examples of working domains for Ammonia-Water Hybrid Compression-Absorption HP

Four different sink and source temperature glides investigated

$$\Delta T_{\text{sink}} / \Delta T_{\text{source}}$$

10K/10K

20K/10K

20K/20K

40K/10K

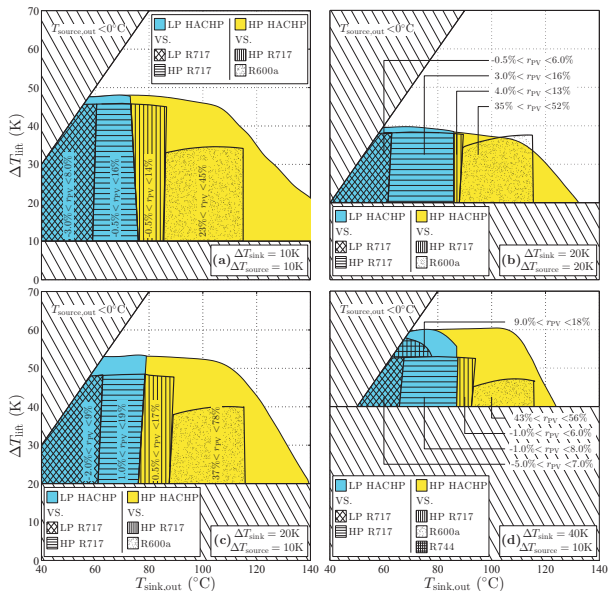



## Differences in investment cost for VCHP and HACHP

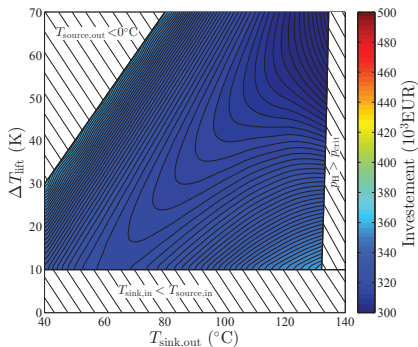

(a) VCHP (R717-HP)

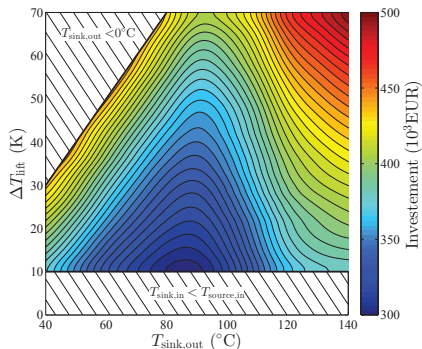

(b) HACHP (R717-HP)

Figure: Investment cost for VCHP and HACHP at  $\Delta T_{\text{sink}}=10 \text{ K}$  /  $\Delta T_{\text{source}}=10 \text{ K}$ .

## Outline for Presentation

### ● Introduction

- Motivation
- Working domains in literature

### ● Method

- Vapour compression heat pump
- Economic assumptions
- Heat exchanger design and calculation
- Influence of key economic assumptions on NPV

### ● Examples of working domains

- Single stage vapour compression HP
- Ammonia-Water Hybrid Compression-Absorption HP

### ● Vapour compression HPs in series

- Vapour compression HPs in series
- COP and NPV
- Comparison with working domain for single stage VCHP

### ● Further steps

- A second economic case
- Two stage VCHP configurations

### ● Discussion

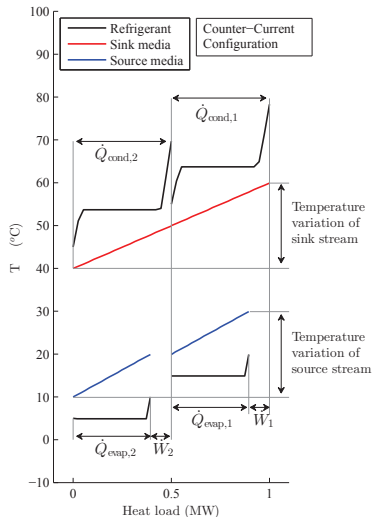

## Vapour compression HPs in series

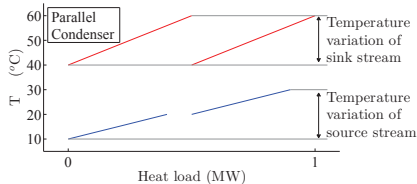
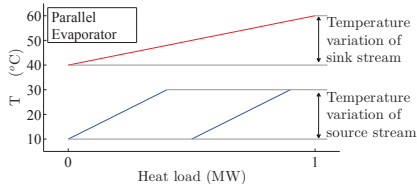
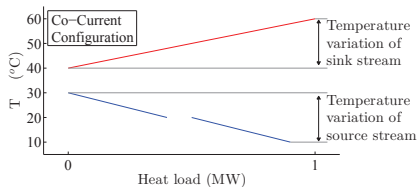
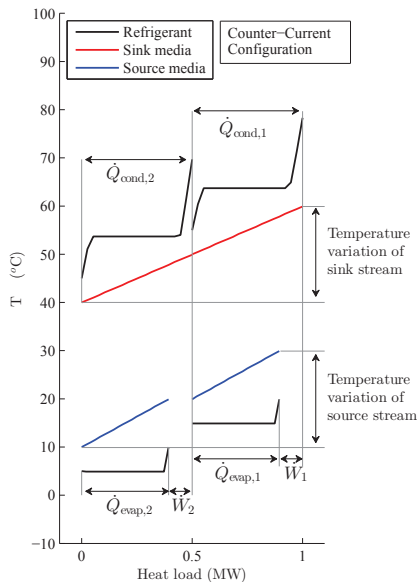

## COP and NPV of VCHPs in series

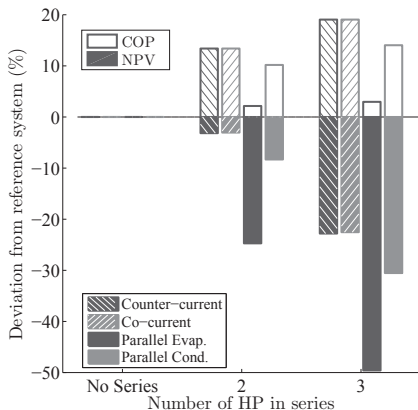

(a)  $\Delta T_{\text{sink}}/\Delta T_{\text{source}} = 20\text{K}/20\text{K}$

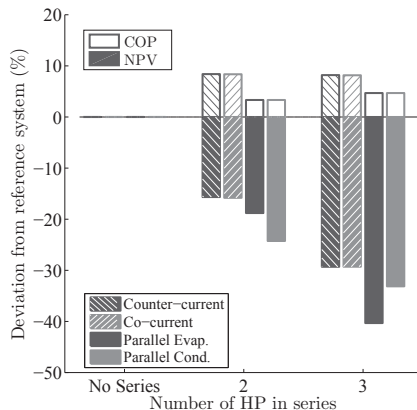

(b)  $\Delta T_{\text{sink}}/\Delta T_{\text{source}} = 40\text{K}/10\text{K}$

Figure: Changes to COP and NPV for four serial connected HP schemes with even heat load for serial connected units. COP and NPV are calculated for R717-HP units in series.

## Load sharing for two vapour compression HPs in series

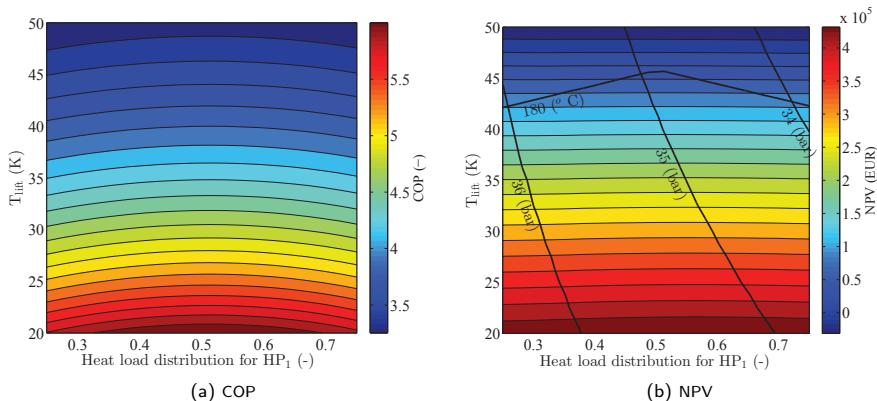
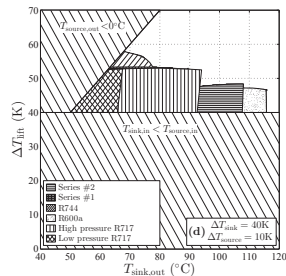
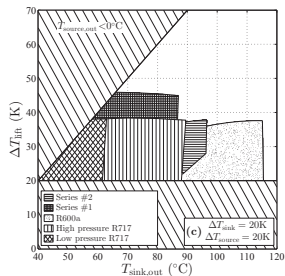
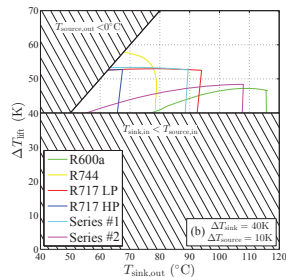
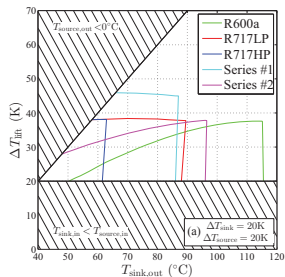

Figure: COP and NPV variations with variation of the heat load fraction and temperature lift. Results are calculated for  $T_{\text{sink}} = 70$  (°C) and  $\Delta T_{\text{sink}}/\Delta T_{\text{source}} = 20\text{K}/20\text{K}$ .

## Comparison with working domain for single stage VCHP

Two different serial connected VCHP investigated

	HP <sub>1</sub>	HP <sub>2</sub>
#1	R717-HP	R717-HP
#2	R600a	R717-HP



## Outline for Presentation

- **Introduction**
  - Motivation
  - Working domains in literature
- **Method**
  - Vapour compression heat pump
  - Economic assumptions
  - Heat exchanger design and calculation
  - Influence of key economic assumptions on NPV
- **Examples of working domains**
  - Single stage vapour compression HP
  - Ammonia-Water Hybrid Compression-Absorption HP
- **Vapour compression HPs in series**
  - Vapour compression HPs in series
  - COP and NPV
  - Comparison with working domain for single stage VCHP
- **Further steps**
  - A second economic case
  - Two stage VCHP configurations
- **Discussion**



## Two economic cases (industrial and DH)

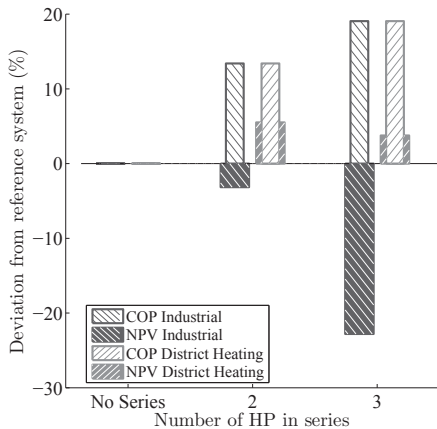

(a)  $\Delta T_{\text{sink}} / \Delta T_{\text{source}} = 20 \text{ K} / 20 \text{ K}$

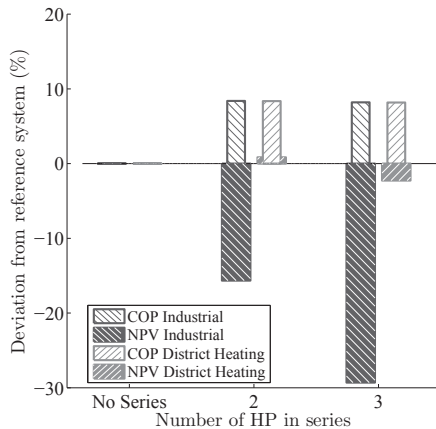

(b)  $\Delta T_{\text{sink}} / \Delta T_{\text{source}} = 40 \text{ K} / 10 \text{ K}$



## Two stage HP configurations

- Individual models for each component
  - A high amount of configurations possible.
  - Generic solutions to optimal configurations are needed.
  - High amount of free variables, eg. oil integration only constrained to intervals.

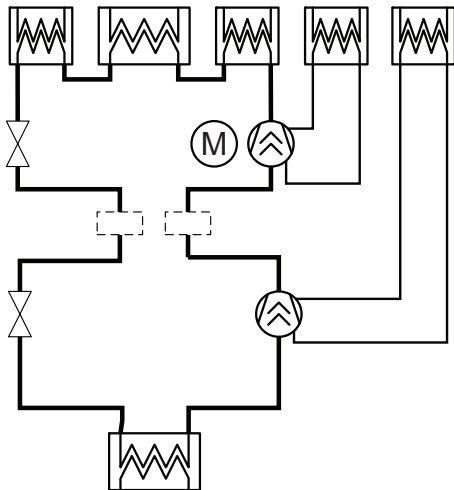

(a) Heat exchangers not fixed connection to heat sink

## HP configurations in series

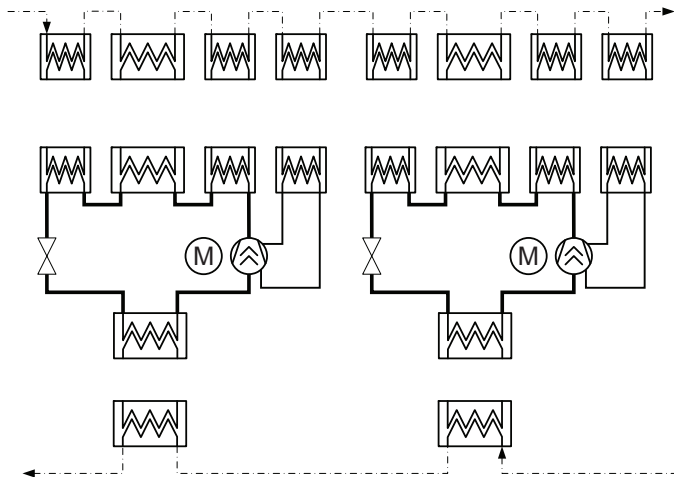

(a) Possibilities for creating various two stage HP cycle layouts

## Outline for Presentation

- **Introduction**
  - Motivation
  - Working domains in literature
- **Method**
  - Vapour compression heat pump
  - Economic assumptions
  - Heat exchanger design and calculation
  - Influence of key economic assumptions on NPV
- **Examples of working domains**
  - Single stage vapour compression HP
  - Ammonia-Water Hybrid Compression-Absorption HP
- **Vapour compression HPs in series**
  - Vapour compression HPs in series
  - COP and NPV
  - Comparison with working domain for single stage VCHP
- **Further steps**
  - A second economic case
  - Two stage VCHP configurations
- **Discussion**

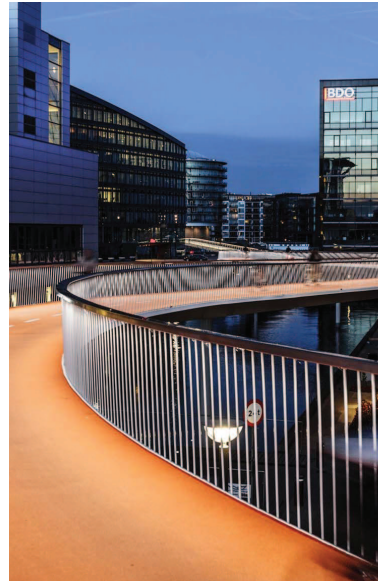

## Important findings from analysis

The analysis of working domains shows, that sink temperatures of up to 120 - 140 °C and temperature lifts 40 - 60 K may be obtained using VCHP and HACHP technologies.

- The NPV is favourable for the technologies utilising R717, but a technical constraint (the discharge temperature) limited the applicability in terms of temperature lift.
- Serial connection of VCHP increases the COP, but at decreased NPV. If more than one heat pump is needed due to capacity constraints, the increase in COP from serial connection of the considered units should be included.
- VCHP in series increases the working domain of current technical and economic constraints. Either due to reduction in resulting discharge temperature of compressor or mixed working fluids selection to obtain combination of certain characteristics.

Further work and analysis is required to obtain generic tool, as a high amount of configurations are possible.

- Input are welcome for other HP configurations, changed temperature sets or economic cases.

## Thank you for your attention

- If questions, new ideas or interest in new projects: [tsom@mek.dtu.dk](mailto:tsom@mek.dtu.dk)

### Work funded by:

- Copenhagen Cleantech Cluster
- Dong Energy
- DTI
- DTU
- EUDP

- Ahlsell Danmark ApS (2013). Priskatalog 2013. [accessed 26.09.13].
- Brunin, O., Feidt, M., and Hivet, B. (1997). Comparison of the working domains of some compression heat pumps and a compression-absorption heat pump. *International Journal of Refrigeration*, 20(5):308.
- FK Teknik A/S (2013). Priskatalog 2013. [accessed 26.09.13].
- H. Jessen Jörgensen A/S (2013). Priskatalog 2013. [accessed 26.09.13].
- Jensen, J., Ommen, T., Markussen, W., Reinholdt, L., and Elmegaard, B. (2015). Technical and economic working domains of industrial heat pumps: Part 2 - ammonia-water hybrid absorption-compression heat pumps. *International Journal of Refrigeration*.
- Johnson Controls, Inc. (2013). HPO R717 compressor cost - non-disclosure agreement. private communication.
- Martin, H. (1996). A theoretical approach to predict the performance of chevron-type plate heat exchangers. *Chemical Engineering and Processing: Process Intensification*, 35(4):301–310.
- Ommen, T., Jensen, J., Markussen, W., Reinholdt, L., and Elmegaard, B. (2015a). Technical and economic working domains of industrial heat pumps: Part 1 - single stage vapour compression heat pumps. *International Journal of Refrigeration*.
- Ommen, T., Jensen, J., Markussen, W., and Elmegaard, B. (2015b). *Enhanced technical and economic working domains of industrial heat pumps operated in series*. The International Institute of Refrigeration.
- SWEP International AB (2013). SWEP - products and solutions - non-disclosure agreement. private communication.

- Yan, Y. Y. and Lin, T. F. (1999). Evaporation heat transfer and pressure drop of refrigerant r-134a in a plate heat exchanger. *Journal of Heat Transfer*, 121(1):118–127.
- Yan, Y. Y., Lio, H. C., and Lin, T. F. (1999). Condensation heat transfer and pressure drop of refrigerant r-134a in a plate heat exchanger. *International Journal of Heat and Mass Transfer*, 42(6):993–1006.