

## RES Hydrogen: efficient pressurised alkaline electrolysers

**Bowen, Jacob R.; Bentzen, Janet Jonna; Jørgensen, Peter Stanley; Zhang, Wei**

*Publication date:*  
2015

*Document Version*  
Publisher's PDF, also known as Version of record

[Link back to DTU Orbit](#)

*Citation (APA):*  
Bowen, J. R., Bentzen, J. J., Jørgensen, P. S., & Zhang, W. (2015). RES Hydrogen: efficient pressurised alkaline electrolysers. DTU Energy Conversion.

## DTU Library

Technical Information Center of Denmark

---

### General rights

Copyright and moral rights for the publications made accessible in the public portal are retained by the authors and/or other copyright owners and it is a condition of accessing publications that users recognise and abide by the legal requirements associated with these rights.

- Users may download and print one copy of any publication from the public portal for the purpose of private study or research.
- You may not further distribute the material or use it for any profit-making activity or commercial gain
- You may freely distribute the URL identifying the publication in the public portal

If you believe that this document breaches copyright please contact us providing details, and we will remove access to the work immediately and investigate your claim.

# RES Hydrogen: efficient pressurised alkaline electrolyzers

DTU Energy Conversion

Partners via FCH JU REselyser project:  
Deutsches Zentrum Für Luft - Und Raumfahrt Ev  
Vlaamse Instelling Voor Technologisch Onderzoek N.V.  
Hydrogenics Europe Nv

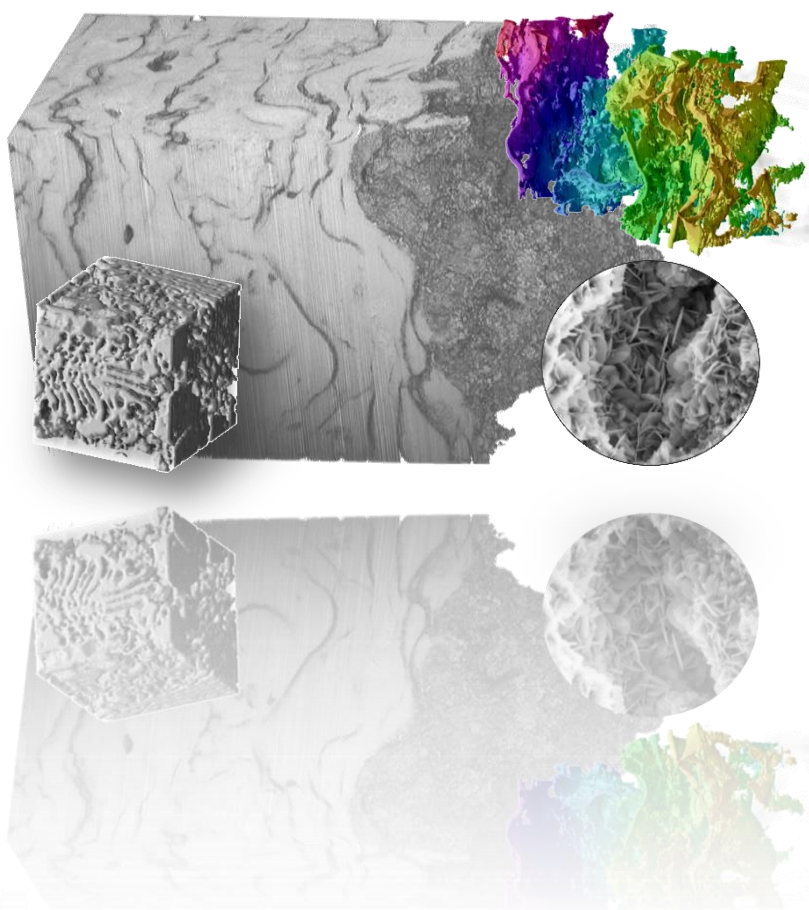

## Contents

Contents	2
Final report	3
1.1 Project details	3
1.2 Short description of project objective and results	3
1.3 Executive summary	4
1.4 Project objectives	5
1.4.1 FCH project objective summary	5
1.4.2 Risks of the planned work	6
1.4.3 Evolution of planned work	6
1.5 Project results and dissemination of results	7
1.5.1 Brief summary of overall project results	7
1.5.2 Electrode characterisation Results	7
1.5.3 Dissemination	13
1.6 Utilization of project results	14
1.7 Project conclusion and perspective	14

Compiled and written by Jacob R. Bowen

Contributors: Janet Jonna Bentzen, Peter Stanley Jørgensen, and Wei Zhang

# Final report

## 1.1 Project details

<b>Project title</b>	RESelyser
<b>Project identification (program abbrev. and file)</b>	2012-1-10818
<b>Name of the programme which has funded the project</b>	ForskEL
<b>Project managing company/institution (name and address)</b>	DTU Energy Conversion Technical University of Denmark Frederiksborgvej 399, 4000 Roskilde
<b>Project partners</b>	Via FCH JU RESelyser project: (DLR) Deutsches Zentrum Fuer Luft - Und Raumfahrt Ev (VITO) Vlaamse Instelling Voor Technologisch Onderzoek N.V. (HYG) Hydrogenics Europe Nv
<b>CVR</b> (central business register)	30 06 09 46
<b>Date for submission</b>	29-06-2015

## 1.2 Short description of project objective and results

The RESelyser project addresses issues associated with coupling alkaline electrolysis to renewable energy sources such as electrode stability and gas purity by implementing improved electrodes and a new separator membrane concept. The project aims to improve performance, operation pressure and reduce system cost. The project supports DTU Energy's activities on electrodes within the larger FCH-JU project. The overall project demonstrated: improved electrode efficiency also during cyclic operation, safe gas purity at a system pressure of 30 bar, 10 kW stack operation and estimated system costs including BoP. Investigation of cathodes revealed highly heterogeneous microstructures and 3D microstructure quantification methods were developed. Nanometre scale  $\beta$ -Ni(OH)<sub>2</sub> formation was identified on tested cathode surfaces and is considered a potential degradation mechanism that is not presently well understood.

RESelyser projektet har undersøgt de problemer der opstår, når alkalisk elektrolyse anvendes i forbindelse med vedvarende energikilder, så som elektrode stabilitet og renhed af gasser. Dette er gjort ved at udvikle forbedrede elektroder og at implementere et nyt membran adskillelses koncept. Projektets mål er at forbedre ydeevnen, forøge trykket samt at reducere de samlede omkostninger for systemet. Projektet støtter DTU Energis elektrode aktiviteter inden for det større FCH-JU projekt. Det overordnede projekt har demonstreret følgende: forbedret elektrode effektivitet også ved cyklisk kørsel, sikker gas renhed ved et system tryk på 30 bar, kørsel af en 10 kW stak og bestemmelse af system omkostningerne inklusiv balance of plant. Undersøgelser af katoder viste meget heterogene mikrostrukturer og metoder til at kvantificere egenskaber af 3D mikrostrukturer blev udviklet. Nanometer store  $\beta$ -Ni(OH)<sub>2</sub> formationer blev fundet på de testede katodeoverflader, disse betragtes som en potentiel degraderings mekanisme som på nuværende tidspunkt endnu ikke er fuldt ud forstået.

### 1.3 Executive summary

The RESelyser project supports the activities of DTU Energy in the FCH-JU project entitled Hydrogen from RES: pressurised alkaline electrolyser with high efficiency and wide operating range (Grant Agreement number 278732). The FCH-JU project co-ordinated by Deutsches Zentrum fuer Luft - Und Raumfahrt (DLR) addresses the issues of coupling alkaline electrolysers to renewable energy sources such as solar and wind power. Conventional alkaline electrolysers are designed to operate under steady state conditions and when subject to fluctuating and intermittent power from renewable energy sources gas purity and safety as well as electrode stability are compromised. RESelyser addresses these issues with a new separator membrane developed by Vlaamse Instelling Voor Technologisch Onderzoek (VITO) and cell concept to limit undesired hydrogen and oxygen cross-contamination, improved electrodes developed by DLR to counter electrode stability issues that also improve efficiency, and the development of balance of plant to operate RESelyser alkaline electrolysis stacks also built by Hydrogenics Europe (HYG). DTU Energy analyses the microstructure of the highly porous vacuum plasma sprayed (VPS) Raney Ni catalyst electrode coatings. In addition RESelyser aims to increase operation pressure and reduce total system cost.

RESelyser has met most of its objectives by successfully developing and testing a new electrolyser concept incorporating the new separator membrane, electrodes and balance of plant to operate electrolysers under renewable energy relevant scenarios. The project has demonstrated improved electrical efficiency, efficiency retention under cyclic operation, increased system pressure, safe levels of gas purity at low power operating points and on target predicted total system cost.

ForskEL co-funded electrode characterisation activities have led to the following understanding of the production and operation of VPS Raney Ni electrodes developed within the RESelyser project. Anodes and cathodes produced by VPS contain a highly heterogeneous microstructure with features ranging from 50 nm to 20  $\mu\text{m}$  in scale in the as sprayed state. Activation of the electrodes creates similar scale porosity by the dissolution of Al rich phases. Studies of cathodes reveal the following. Fine scale porosity is generated by dissolution of dendritic structures within original powders that survive the spraying process. Coarse scale porosity is created by the dissolution of partially melted original particle surfaces to create wavy planar pores at the interfaces between original particles. The fine scale porosity is connected to the coarse scale porosity which is expected to function as escape pathways for dissolved hydrogen or hydrogen gas bubbles that may be generated deep within the nanometre scale pores. The fine and coarse scale pore morphology was investigated in two and three dimensions with the aim to characterise electrode degradation in terms of changes in porosity. An unexpected formation of nano-crystalline  $\beta\text{-Ni(OH)}_2$  in the form of "desert rose" shapes was observed on cathode external and internal pore surfaces after electrolysis operation. The  $\beta\text{-Ni(OH)}_2$  was identified by X-ray and transmission electron diffraction. Its formation was considered to be a potentially serious electrode degradation mechanism due to its unknown electrochemical properties and the potential to block the pore network. The  $\beta\text{-Ni(OH)}_2$  was observed to form porous layers and macroscopic surface area measurements suggest that its formation increases the specific surface area of the electrode. Investigations into the conditions of formation revealed that its growth was enhanced by electrolysis operation and that the desert rose morphology can be nucleated by water storage of activated cathodes where increased water storage time correlates to growth; although it is expected this is a second order effect compared to the influence of electrolysis operation.  $\beta\text{-Ni(OH)}_2$  stability is expected by Pourbaix diagrams at electrolyte pH values close to the operation point of the electrolyser however, the exact conditions and the kinetics of formation in terms of the intermittent operation nature of the electrolyser are not presently understood. With the currently available knowledge it has not been possible to conclude the negative or positive effect of the nano-crystalline  $\beta\text{-Ni(OH)}_2$  formation based on the balance of electrochemical properties versus the increase of surface area. The aim of quantifying the 3D microstructural parameters describing the complete pore space in order to describe pore space change in terms of electrode production parameters and performance was not achieved. The highly heterogeneous length scales and chaotic nature of the microstructure prevented the collection of statistically representative volumes of sufficient resolution to extract meaningful

microstructure measures. Collected 3D data however allowed the development of quantitative methods for characterising this general type of electrode pore structures. With the present rapid advances of 3D microstructure reconstruction techniques it is expected that larger and statistically representative high resolution 3D data will become available in the future.

The RESelyser project as a whole has developed and proven the potential of coupling alkaline electrolysis to renewable energy sources. Specifically it has developed separator membrane, cell and stack concepts and electrodes that can be exploited by the industrial partner or other parties willing to licence the technology. Project results have been disseminated at several international conferences and the results of electrode characterisation are in preparation for publication in an international journal.

## **1.4 Project objectives**

### *1.4.1 FCH project objective summary*

The RESelyser project objectives address several aspects of alkaline water electrolysis for hydrogen production in the context of coupling the well-established technology to renewable energy sources and their associated fluctuating power output. When exposed to fluctuating power input, conventional alkaline electrolyzers face issues during low power and intermittent operation. These include electrode stability and gas purity. Electrode degradation adversely affects electrolyser performance operational expenses, whereas gas purity affects the quality of the produced gasses but also has safety issues in terms of hydrogen and oxygen mixtures. The overall RESelyser technology objectives are summarised by: targeting cost reduction, efficiency improvements and simultaneously providing a wide range of operation conditions in terms of power and system pressure. The quantifiable project targets are to: improve efficiency >80% (HHV) at  $0.75 \text{ Acm}^{-2}$ , operating temperatures up to  $100^\circ\text{C}$ , >90% efficiency retention after >1000 on/off cycles, and a system cost of  $3 \text{ k€ Nm}^3 \text{ h}^{-1}$  (See Table 1 in Appendix 1 for more detail). The final demonstration objectives of RESelyser are to produce a 10 kW electrolyser with an operation pressure of 10 bar and a small scale electrolyser demonstrating the RESelyser concept to an operation pressure of 50 bar. Increases in system pressure open the electrolyser to markets such as power-to-gas where hydrogen is injected at  $\sim 50$  bar directly into the natural gas transmission grid allowing the electrolyser to perform peak-shaving of intermittent renewable energy sources.

RESelyser addresses the aforementioned challenges by developing a new alkaline electrolyser incorporating improved components and a novel cell design concept avoiding the use of expensive materials. To improve gas impurity RESelyser develops a new cell concept demonstrating the incorporation of the advanced "e-bypass" separator membrane. The new membrane separating the hydrogen (catholyte) and oxygen (anolyte) compartments is a double layer membrane with a central electrolyte compartment. Electrolyte flows from the centre channel through the membranes to the anolyte and catholyte compartments thus hindering back diffusion of dissolved hydrogen and oxygen gas to the incorrect compartment. See Figure 1 in the appendix for a schematic diagram and image of the e-bypass membrane. To improve electrode stability, VPS Raney Ni coatings on classical Ni metal sheet electrodes developed in the 1990's for alkaline electrolysis are to be scaled up to larger electrodes. The aim of RESelyser is also to transfer VPS advances gained from solid oxide fuel cell (SOFC) electrode production to create large specific surface area electrodes to improve electrolyser efficiency and stability. At the system level RESelyser aims to develop the required balance of plant required to operate the new electrolyser under conditions relevant for integration with renewable energy supply (solar or wind) either in on-grid or off-grid scenarios.

The above describes the general objectives of the entire RESelyser project funded by the European Union Fuel Cells and Hydrogen Joint Undertaking. Specifically this report details the activities undertaken by DTU that were co-financed in the form of a top-up ForskEL project. These activities are described in §1.4.1.1 AND §1.4.1.2 below and fall into the work tasks 4.2 and 4.4 in the FCH-JU description of work. ForskEL co-funded activities are related only to the characterisation of Raney Ni coatings that function as the active electrodes in the electrolyser.

#### **1.4.1.1 Task 4.2 Development of high surface electrodes using Plasma Spraying**

Based on previous work on plasma sprayed electrolyser electrodes the plasma spray technology is applied to deposit highly porous cathodes on the basis of NiAlMo alloy and anodes on the basis of NiAl/mixed oxide composites (FCH-JU Task 4.1). The composition and the structure of the electrode deposits before and after the leaching process (activation process) are characterized by X-ray diffraction (XRD) and scanning electron microscopy (SEM). The electrochemical properties of the electrodes are checked by means of cyclic voltammetry. The parameters and processes of the plasma spraying will be further developed to obtain an improved electrode performance and reduced costs. Electrodes will be prepared at up to 300 cm<sup>2</sup> size.

DTU Energy Conversion will closely collaborate on the characterisation of the electrodes produced in this task and will perform conventional SEM analyses in order to fully understand the nature of the structures produced and their relation to electrochemical performance and processing methods. This will form the foundations of the 3D porosity characterisation to be performed in Task 4.4.

#### **1.4.1.2 Task 4.4 Porosity characterization of the electrodes**

Selected electrodes (both cathodes and anodes) critical to the progress of the project will be subject to porosity characterisation by tomographic methods. Depending on the scale of the electrode microstructure either focused ion beam (FIB) tomography or x-ray computed tomography (XCT) will be applied. For each electrode the specific surface area will be determined and compared to conventional porosimetry measurements. Furthermore detailed analysis of the pore space morphology will be performed in order to determine parameters such as average pore size, average pore depth and pore bottle necks. This will be achieved by the use of so called "distance maps" calculated from the 3D data. Samples subjected to different processing parameters and operating conditions will be compared on the basis of these parameters in relation to their electrochemical performance. Data analysis will also be extended to interpret the electrode morphology in terms of the theoretical gas bubble size to understand the mechanisms controlling gas evolution and to explain why one electrode morphology performs better than another. Plausible reasons may be related to morphology parameters such as pore bottle neck dimensions and pore (bubble escape) depth in addition to the global specific surface area.

#### *1.4.2 Risks of the planned work*

The major risk associated to the two work tasks above is related to the potential failure of the VPS process used to produce the electrodes in the form of highly porous Raney Ni coatings. In the event of coating failure the contingency plan of the EU project is to use the uncoated expanded Ni metal sheet substrate as a conventional electrode. In such case task 4.2 would be dedicated to evaluation of the cause of failure and characterisation of the substitute electrodes as necessary.

#### *1.4.3 Evolution of planned work*

During the course of the project several challenges were encountered requiring changes to the planned work. As described in the mid-term report, the activities described in §1.4.1.1 and 1.4.1.2 were delayed due to delays in electrode production and delivery to DTU. These delays were however not significant in terms of the overall project deliverables and milestones.

A major challenge encountered in the project was the microstructural heterogeneity of the VPS Raney Ni electrodes. The main objective of the planned activities was to characterise the size and shape of the pore space network and relate this to electrode production and performance parameters. The length scale of the pores within the electrodes was found to be between ~50 nm to ~20 µm. The small scale pores are on the practical resolution limit for FIB tomography and the large scale pores are typically larger/longer than the typical dimensions of volumes sampled by FIB tomography. To counter this issue, a combination of coincident synchrotron X-ray and FIB tomography was prepared to produce low (with a large sampling volume) and high resolution 3D reconstructions to span the full length scale of the porous network. Synchrotron beamtime was successfully applied for and sample preparation methods were developed. This experiment however failed due issues of the synchrotron facility.

Due to the project time frame it was not feasible to apply for more beamtime to repeat the experiment. It was therefore not possible to make meaningful quantitative links between microstructural parameters describing the pore space to production or performance parameters as the 3D reconstructions acquired could not statistically describe the complete pore space representatively. Nonetheless, the collected data allowed the development as planned of an analysis procedure to quantify the pore space within 3D reconstructions based on 3D distance maps. Continuation of this activity was justified to prepare for the rapid developments presently occurring in X-ray and FIB tomography in terms of spatial resolution and sampling volume. As such, in the near future it is foreseeable that representative reconstructions of heterogeneous pore spaces will become feasible.

A second unexpected challenge was the observation of the growth of unknown crystals on cathode external and internal pore surfaces detected after single electrode testing. This was an unexpected "electrode" degradation mechanism. At the project outset it was expected that electrode degradation mechanisms would be associated to changes of the pore space by "corrosion" or fragmentation of the Raney Ni electrodes not by the growth of secondary phases. It was therefore necessary to redirect un-used resources planned for the aforementioned 3D reconstruction work to the identification of the crystals as a nickel hydroxide phase and the main parameters influencing its formation. The growth of the nickel hydroxide was evaluated to have potential serious consequences for electrode performance. This unexpected task restricted available resources, thus in agreement with the consortium electrode characterisation was focused on the cathode and anode analyses were limited.

## **1.5 Project results and dissemination of results**

### *1.5.1 Brief summary of overall project results*

The outcome of the whole RESelyser project is demonstrated in terms of the aforementioned objectives by the following quantifiable results:

- Total efficiency  $\eta=76\%$  on HHV basis at a current density of  $0.75 \text{ A/cm}^2$  in a  $300 \text{ cm}^2$  cell,  $82\%$  for smaller cell
- Materials used suitable for  $100^\circ\text{C}$ , tests up to  $90^\circ\text{C}$
- Electrode potential  $98\%$  of initial efficiency over 1100 on/off switching cycles
- Estimate  $2,300 \text{ €}/(\text{Nm}^3/\text{h})$  plant capacity stack costs ( $2500 \text{ cm}^2$  cells) running at 65 bar,  $7\text{k€}/(\text{Nm}^3/\text{h})$  for a Hex. S1000 65barg RESelyser system
- The gas impurity ( $\text{O}_2$  in  $\text{H}_2$ ) at 30 bar was approximately the same as for 10 bar in a conventional electrolyser stack. Similar improvement was also obtained for  $\text{H}_2$  in  $\text{O}_2$ . i.e. the electrolyser can be run at a much higher pressure.

As evidenced by the maintenance of performance during on/off cycles, increased operation pressure, total efficiency close to the target the project and that the industrial partner can exploit the project results, RESelyser has brought alkaline electrolysis coupled to renewable energy sources closer to the market. According to the environmental challenges outlined in the application the project has made progress towards  $\text{CO}_2$  reduction enabled by renewable electricity storage in natural gas transmission systems and  $\text{CO}_2$  neutral hydrogen production for transportation.

For more information on the overall project results see Appendix 1.

### *1.5.2 Electrode characterisation Results*

Raney Ni raw powders and electrodes produced by VPS were characterised in the as-sprayed, activated and tested conditions by scanning (SEM) and transmission electron microscopy (TEM), X-ray diffraction and Brunauer–Emmett–Teller theory (BET). In general, SEM revealed that the electrode microstructure for both anodes and cathodes in all conditions is a highly heterogeneous and chaotic structure with microstructural features in the range of approximately  $50 \text{ nm}$  to  $20 \text{ }\mu\text{m}$  distributed throughout the electrode thickness (see Figure 1). The majority of investigations however, concentrated on the cathode / hydrogen electrode for the reasons explained in §1.4.3. Cathode surfaces (see Figure 2), where it is expected a significant portion of the hydrogen evolution occurs, also revealed similar microstructural heterogeneity with a high degree of surface roughness and surface porosity.

Initial SEM analyses of VPS of both anodes and cathodes detected the presence of impurity elements and their size and frequency of occurrence. These impurities were associated with



unstable electrode performance of early generation electrodes. A successful analysis led to the isolation of the source of impurities and subsequent improvement of the electrodes.

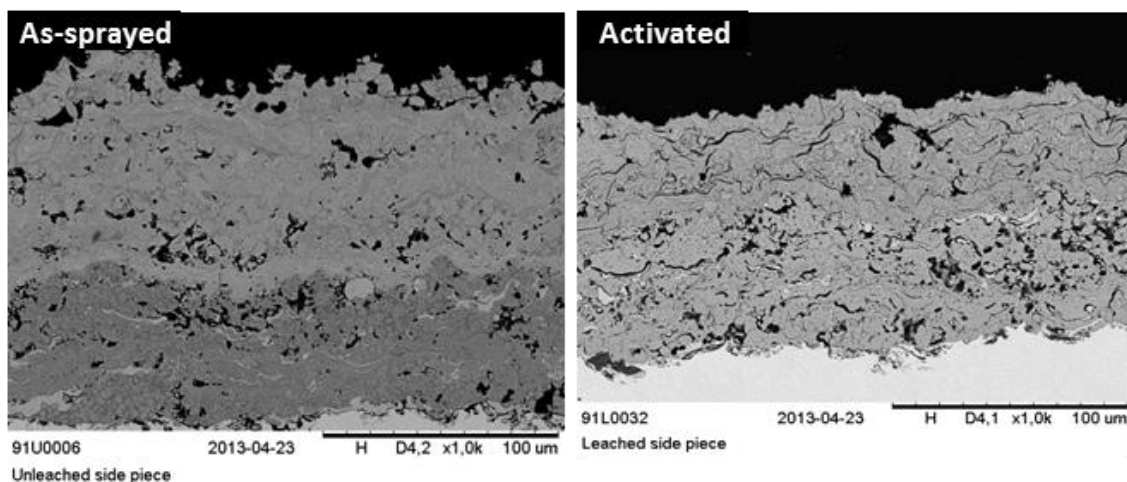

Figure 1: Cross-sectional SEM images of vacuum plasma sprayed Raney Ni hydrogen electrodes in the as-sprayed (left) and activated state (right). The cathode consists of two layers on the Ni substrate: the outer Al-Ni-Mo active surface layer and the inner Al-Ni bonding layer.

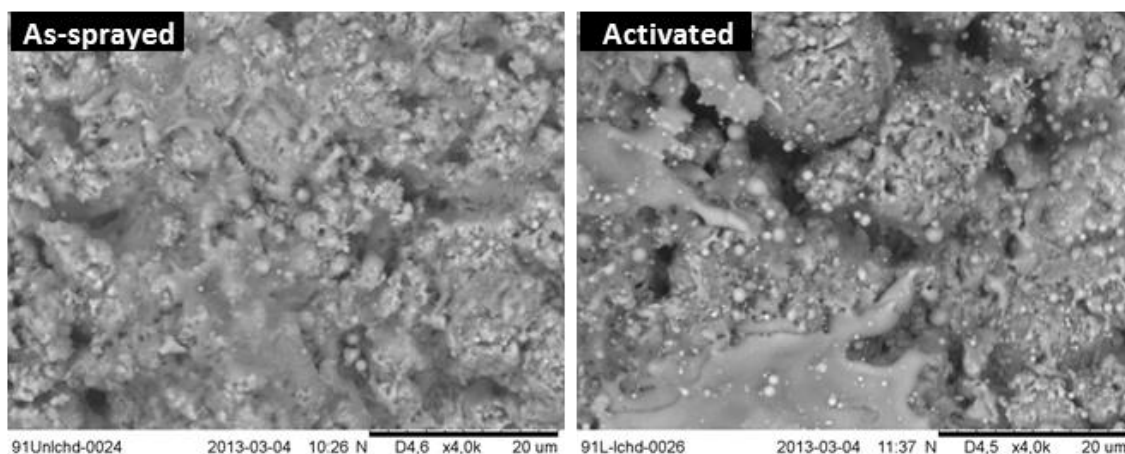
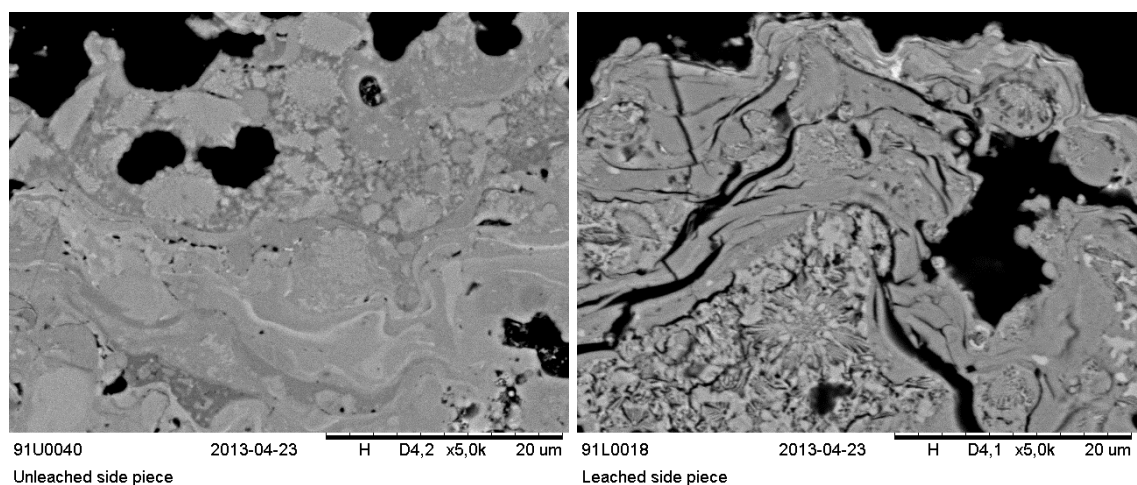

Figure 2: SEM surface images of vacuum plasma sprayed Raney Ni hydrogen electrodes in the as-sprayed (left) and activated state (right).

In the as-sprayed state, the two layer cathode structure is relatively dense on the scale of the electrode thickness where porosity of random shape is associated with regions between the original powder particles that have not completely melted together during the VPS process. Focusing on the Al-Ni-Mo outer and electrochemically active cathode layer it was seen that upon activation, a significant volume fraction of porosity is created at the interfaces between original particles bonded by particle surface melting. Atomic number sensitive SEM imaging revealed that at these interfaces associated with surface melting prior to activation had different average composition and microstructure compared to the corresponding original particle interiors. The selective dissolution of these interfaces during activation is attributed to these structural and compositional differences. The porosity created by this mechanism creates long distorted channels ( $\sim 1\mu\text{m}$  in width) that extend for tens of microns and lay approximately parallel to the electrode surface. Figure 3 (left) shows bright wavy shaped differences in brightness which correspond to the similarly shaped pores (black) in the activated state (right). The channels in three dimensions have a distorted planar structure as seen in Figure 4. These coarse scale pores are expected to function as escape pathways for hydrogen evolved within the porous cathode. The planar and electrode surface parallel nature of these coarse pores is not expected to be ideal for efficient gas transport or electrode mechanical stability and thus have the potential to be improved. High resolution imaging showed nanometre scale dendritic structures that survive the VPS process corre-

spond to original particle interiors. These are selectively etched dissolving the Al rich phases to leave a highly porous nanometre scale structure consisting mostly of Ni (see Figure 5 ). As the nanometre scale dendritic porosity is created by the activation process, it is interconnected to the large distorted planar pores at least after activation. Based on transmitted X-ray intensity the electrode X-ray absorption is a factor of approximately two lower than that calculated for the fully dense alloy suggesting that the total porosity of the cathode is significant.



*Figure 3: As sprayed (left) and leached (right) VPS Raney Ni cathodes.*

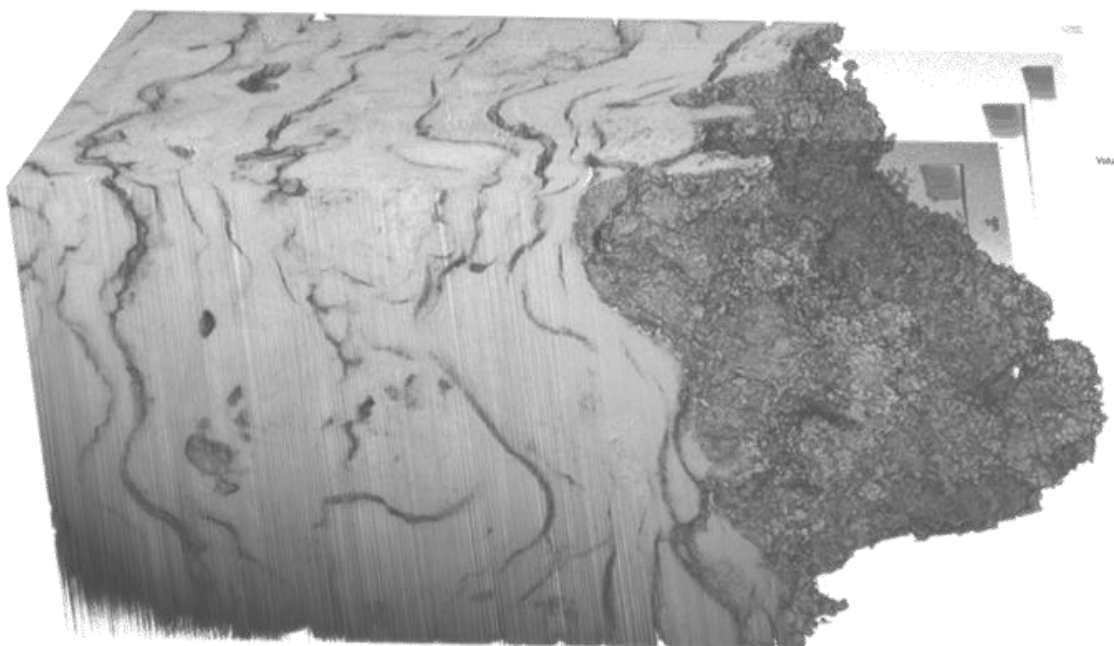

*Figure 4: Three dimensional reconstruction of a tested cathode by focused ion beam tomography revealing surface topography (right side) and coarse scale internal porosity. Volume dimensions 75 x 30 x 45  $\mu\text{m}$  (note: top right corner features are image processing artefacts).*

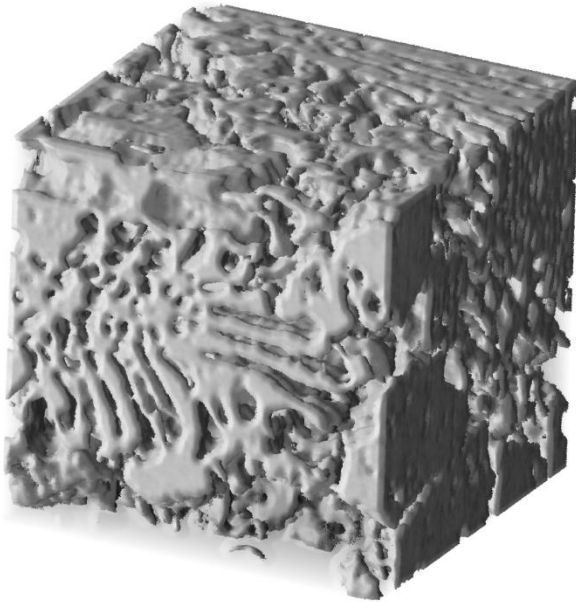

Figure 5: High magnification 3D rendering of nanoscale porosity created after activation (cube sides are 2  $\mu\text{m}$ ).

After long term cathode testing, nanometre scale crystallites were observed to grow with "desert rose" crystal morphology on the electrode surface (see Figure 6) and on the surfaces of coarse scale internal pores. Bulk XRD of electrode surfaces and TEM diffraction studies of extracted nano-crystallites confirmed that the desert rose was  $\beta\text{-Ni}(\text{OH})_2$ .

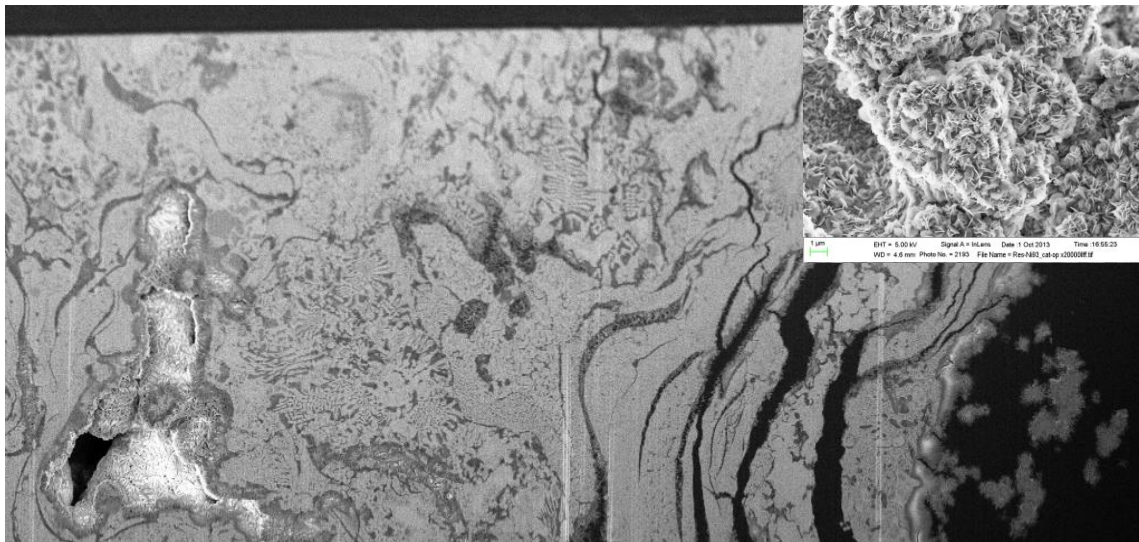
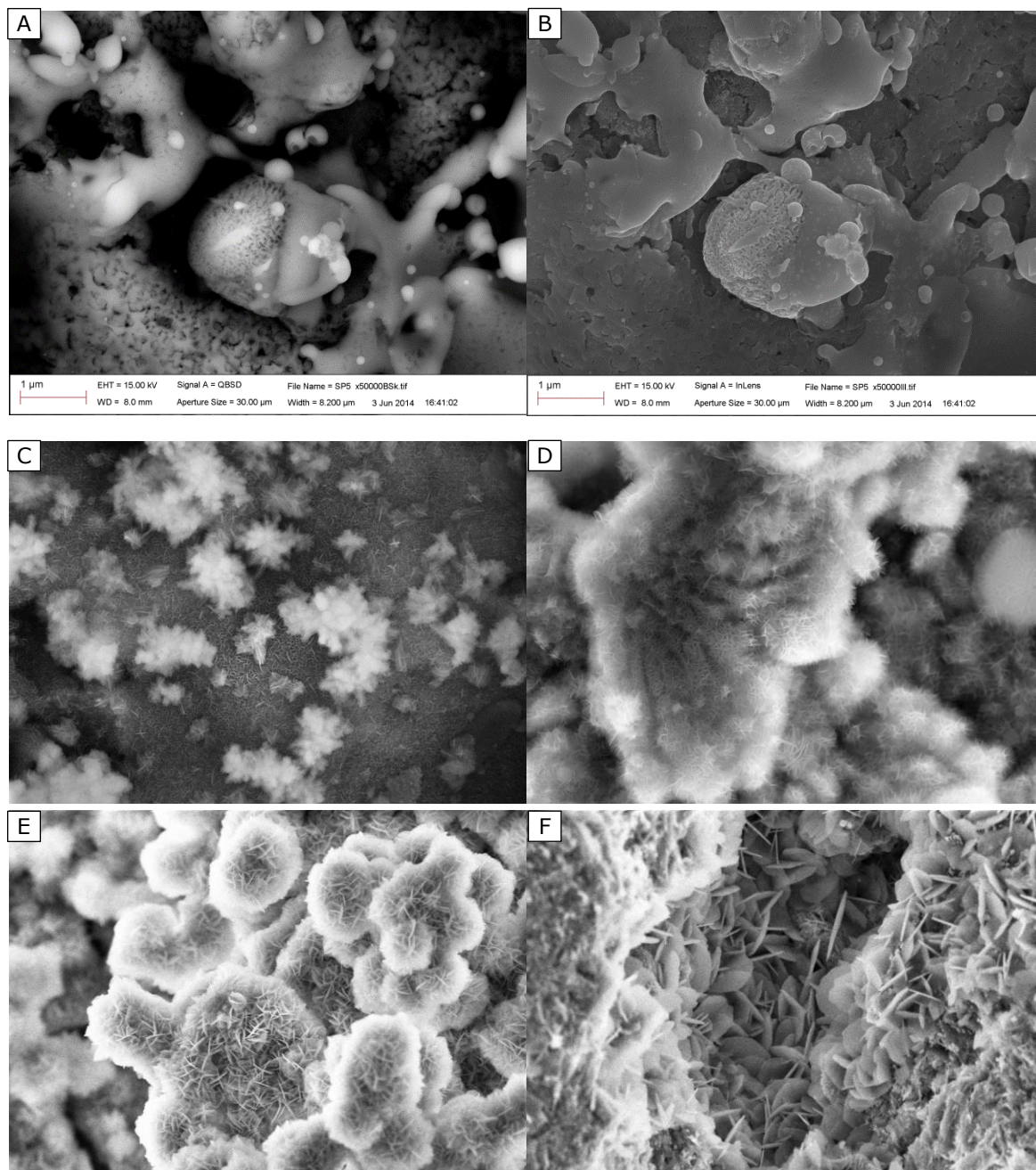

Figure 6: Nanometre scale desert rose morphology  $\beta\text{-Ni}(\text{OH})_2$  formed on cathode surfaces after short term testing. Formation can be seen on the cathode free surface (right) and on internal pore surfaces that can be located deep within the electrode (image width 50  $\mu\text{m}$ ). The higher magnification inset reveals the  $\beta\text{-Ni}(\text{OH})_2$  as seen from the electrode free surface of a long term tested cathode.

Figure 7 shows the evolution of the  $\beta\text{-Ni}(\text{OH})_2$  formation as a function of water storage and electrolysis conditions. Based on semi-quantitative analysis of the crystallites the extent of  $\beta\text{-Ni}(\text{OH})_2$  formation and growth was found to primarily correlate to electrolysis duration and that water storage of activated electrodes and powders also lead to the nucleation and growth of desert rose structures to a lesser degree. From the available electrode test and post mortem microscopy data it is not possible to conclude under which conditions the  $\beta\text{-Ni}(\text{OH})_2$  formation growth kinetics are greatest due to the complex test history that emulates intermittent electrode operation in a renewable energy scenario. It is not known if the growth is associated with hydrogen evolution under current or when the electrode is passive at open circuit voltage. According to Pourbaix diagrams[1] for pure Nickel available in the



literature  $\beta$ -Ni(OH)<sub>2</sub> is stable over a wide range of pH in highly basic solutions adjacent to but at lower pH than the operation conditions of the electrode. This suggests that variations in pH are required to induce the formation of  $\beta$ -Ni(OH)<sub>2</sub>. However, how the Al and Mo of the electrode alloy affects the stability regions of the Pourbaix diagram is not known.

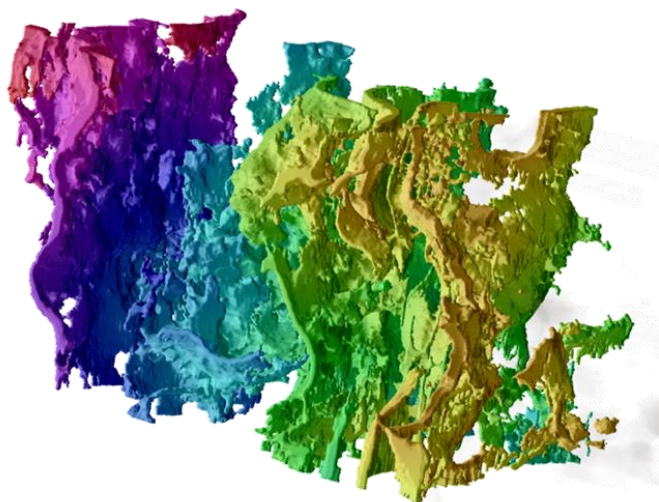

*Figure 7: Formation of desert rose nano flakes on the NiAlMo HYDROGEN electrode surfaces and in pores as a function of sample history. SEM images of a&b) as-leached; c) leached, washed and stored in water 3 days; d) leached, washed and stored in water 210 days; e) leached, washed and stored 120 days in water, and operated as electrode for ~30 min.; f) leached, washed, stored 90 days in water, and operated as electrode for 28 days. All images are secondary electron images except for a) showing atomic number contrast, all images at same magnification.*

Presently the electrochemical performance implications of nanometre scale  $\beta$ -Ni(OH)<sub>2</sub> formation on hydrogen electrodes has not been fully ascertained as on the one hand its formation leads to a significant increase in available surface area for hydrogen evolution, but on the other hand the electrical conductivity of this nanometre scale morphology is unknown. Furthermore its formation can lead to the filling of the coarse pores with crystals potentially creating an impermeable barrier to hydrogen evolution. It is concluded that the  $\beta$ -Ni(OH)<sub>2</sub>

formation has the potential to become a serious cathode degradation mechanism and further research in the form of targeted electrochemical testing is recommended to quantify formation rates and safe cathode operational parameters.

The coarse and fine scale porosity in short and long term tested cathodes was visualised by focused ion beam tomography (see Figure 4). Several volumes of cathodes were reconstructed to visualise the pore structure within the short and long term tested cathodes providing a useful qualitative visualisations of the pore structure. Despite the large total volume of reconstructed electrode it was not possible to capture a large number of complete coarse scale pores. Thus statistically representative quantification of the coarse scale porosity in terms of microstructural parameters was not possible as the reconstructed volumes were smaller than the scale of coarse porosity. However, on the assumption of available representative data, methodologies for quantifying porous microstructure pathways for evolved hydrogen escape from the electrode interior were developed in terms of distances to the electrode free surface (see Figure 8) and identification of bottlenecks. These parameters in addition to classical 3D microstructure descriptors such as specific surface area; pore channel size distributions etc. should be useful in the comparison of various electrodes as a function of operation conditions.



*Figure 8: Distance map rendering of long term tested electrode volume in Figure 4. The colours orange to magenta indicate increasing distance  $s$  from 0 to  $\sim 80\mu\text{m}$  through the pore space from the electrode free surface.*

### 1.5.3 Dissemination

Table 1 summarises the disseminated project results related to electrode characterisation. A complete list of disseminated results is given on pages 28-32 in Appendix 1.

Table 1: Overview of disseminated REselyser results related to electrode characterisation.

Main leader	Presenter / Author	Presentation method, Title	Date	Place
DLR	R. Reissner	Presentation "Pressurised alkaline electrolyser with high efficiency and wide operating range - The Project „REselyser“"	9-12 Dec. 2014	Electrohypem Workshop; Taormina, Italy
DTU	J.R. Bowen	Presentation "Microstructure Analysis of Vacuum Plasma Sprayed Electrodes for Alkaline Water Electrolysis"	7-12 September 2014	IMC International Microscopy Congress 2014; Prague, Czech Republic
DTU	J.J. Bentzen	Poster "Formation of Desert Rose structures in Vacuum Plasma sprayed Electrodes for Alkaline Electrolysis"	7-12 September 2014	International Microscopy CongressMC 2014; Prague, Czech Republic
DTU	J.J. Bentzen	Poster	9-11 June 2015	Submitted: SCANDEM2015 Annual Conference of the Nordic Microscopy Society; Jyväskylä, Finland
DLR	R. Reissner	Presentation	May 2015	Submitted: EST Energy, Science and Technology conference; Karlsruhe, Germany
DLR	R. Reissner	Presentation	30 June – 3 July 2015	Submitted: 5 <sup>th</sup> European PEFC and H2 Forum; Luzern, Switzerland
DTU	J.R. Bowen	Presentation (invited) " Degradation of alkaline electrolyser electrodes "	30 September -2 October 2015	Planned: 3rd International Workshop on Degradation issues in Fuel Cells & Electrolysers; Greece
DTU	J. R. Bowen	Magazine	June 2015	Alkalisk elektrolyse til vedvarende energikilder. FiB nr. 52 p 27. <a href="http://www.biopress.dk/PDF/fib-nr.-52-juni-2015">http://www.biopress.dk/PDF/fib-nr.-52-juni-2015</a>

## 1.6 Utilization of project results

Many of the project results and lessons learned can be exploited at the industrial project partner Hydrogenics for electrolyser production. For the plasma sprayed electrodes as a next step a commercial partner will be sought for a joint development and later supply of the electrodes. For the e-bypass separator licensing will be discussed with VITO and a commercial partner for production.

Any project results can also be licenced to interested parties outside the consortium. Also applications for the materials developed outside the applications considered in this project will be sought.

The results of electrode characterisation will be released to the public domain in the form of a journal article.

## 1.7 Project conclusion and perspective

The RESelyser project as a whole has demonstrated the implementation of a new alkaline electrolyser cell concept containing a new separator membrane that facilitates internal electrolyte circulation combined with improved electrodes at the cell and stack level. Scaling of separator and electrode production to an industrial level is considered economically and technically feasible. Cell and stack testing have demonstrated improved efficiency at higher current density without the use of precious metals, also during intermittent operation as well as operation at high pressure whilst maintaining high gas purity. These general project outcomes have shown that individual components and system concepts are feasible on an industrial scale for hydrogen production by renewable energy supplied alkaline electrolysers.

Advanced microstructure characterisation of vacuum plasma sprayed cathode for hydrogen evolution in terms of raw materials, production procedures and electrode operation has given insight into the role of microstructure. This ForskEl co-funded activity has led to the following conclusions:

- First generation VPS Raney Ni electrodes have a highly heterogeneous and chaotic microstructure due to the VPS process with a wide range of microstructural feature scale (50nm to 20  $\mu\text{m}$ ). Nanometre scale porosity was found to connect to large distorted planar pores. In terms of hydrogen production it is unknown how deep within the porous electrode hydrogen evolution occurs and what fraction of the evolution occurs within the nanometre scale pores. It is expected that the electrode performance could be improved by optimising the morphology of the coarse pores to reduce transport distances to the electrode surface.
- The heterogeneous nature of the electrode pore structure prevented a statistically representative 3D description of the pore space. Large volumes of cathodes were reconstructed in 3D but were not able to capture the coarse scale features representatively due to sampling volume limitations. However, quantitative methodologies were developed for quantifying this type of electrode structure in terms of hydrogen transport distance, pore size distribution and local bottle necks. These methods are ready to be exploited upon development of more homogeneous newer generation electrodes or on larger volume datasets that are expected from recent developments in 3D reconstruction techniques.
- An unexpected formation nanometre scale  $\beta\text{-Ni(OH)}_2$  with mineral desert rose morphology was found to form on the electrode surface and internal pore surfaces of cathodes after electrolysis operation. It was also found that water storage of activated electrodes nucleated the structure whose size increased with storage time. Electrolysis operation was found to be the most significant. Theoretically  $\beta\text{-Ni(OH)}_2$  is not stable at operating conditions and thus its formation is expected to be associated with changes in pH during cyclic operation. However, the precise conditions for formation and its kinetics are presently unknown due to the complex testing history of the investigated electrodes. It was found that the formation of  $\beta\text{-Ni(OH)}_2$  increases surface area but can also block pore spaces. As the electrochemical properties of  $\beta\text{-Ni(OH)}_2$  are not known it is not possible to determine if its formation is detrimental to electrode performance. From these results it is concluded that further work is required to establish the exact conditions and kinetics of formation and that controlled investigations are needed to establish the effects on electrode performance.

## References

1. Beverskog B, Puigdomenech I (1997) Revised Pourbaix diagrams for nickel at 25–300 °C. Corros Sci 39:969–980. doi: 10.1016/S0010-938X(97)00002-4

## Annex

RESelyser home page: <http://reselyser.eu>

Annex 1: RESelyser FCH-JU Project Final Report - Publishable





# **Fuel Cells and Hydrogen Joint Undertaking (FCH JU)**

## **Project Report**

**Collaborative Projects  
Coordination and Support Actions**

*Version 29/06/2015*

# PROJECT FINAL REPORT

**Publishable**

**FCH JU Grant Agreement number:** 278732

**Project acronym:** RESELYSER

**Project title:** Hydrogen from RES: pressurised alkaline electrolyser with high efficiency and wide operating range

**Funding Scheme:** Collaborative Project

**Period covered:** from November 01, 2011 to April 30, 2015

**Name of the scientific representative of the project's coordinator, Title and Organisation:**  
Regine Reissner, Dipl. Phys., Deutsches Zentrum fuer Luft- und Raumfahrt eV.

**Tel:** +49-711-6862-394

**Fax:** +49-711-6862-322

**E-mail:** regine.reissner@dlr.de

**Project website address:** [www.reselyser.eu](http://www.reselyser.eu)

## **TABLE OF CONTENTS**

TABLE OF CONTENTS.....	3
Publishable Summary .....	4
Summary description of project context and objectives .....	5
Project results .....	8
Membrane Diaphragms.....	8
Electrodes.....	9
Cell and Electrolyser Concept.....	14
Small Scale and Technical Scale Electrolyser Tests.....	18
Concept development for autonomous electrolyser – solar/wind energy system.....	24
Project impact .....	28
Socio-economic impact and wider societal impact of the project .....	28
Dissemination activities and exploitation of the results.....	28
Adresses .....	33

## **Publishable Summary**

Alkaline water electrolysis for hydrogen production is a well-established technique available commercially in a wide power range. Hydrogen production by electrolysis is increasingly studied as a way to smoothen the fluctuating power output of renewable energy sources in oversupply situations. It is a way to introduce renewable energy into the transport sector and a necessary element of the energy system transformation in several European countries (e.g. Germany or Switzerland). However, some technological issues regarding the coupling of alkaline water electrolysis and Renewable Energy Sources (RES) remain unaddressed. The project aims at improving present electrolyzers for the specifics of direct coupling to fluctuating power operation. Also system costs have to be decreased to reach a low cost but high-efficiency energy conversion.

To address these challenges the project REselyser - Hydrogen from RES: pressurised alkaline electrolyser with high efficiency and wide operating range - developed and investigated a new alkaline water electrolyser with improved components and a novel concept. A new separator membrane with internal electrolyte circulation (“e-bypass-separator”) and an adapted design of the cell to improve mass transfer, especially to reduce gas impurities at high pressures and low power operation, was investigated and demonstrated. Intermittent and varying load operation with RES is addressed by good electrode stability and improved efficiency in the new cell concept. Also the system architecture is optimized for intermittent operation of the electrolyser. The project partners combine their know how and experience to achieve the project objectives: the project coordinator DLR improves the electrodes, performs single cell tests and works on system concepts, VITO prepares new separator membranes, DTU characterises the electrode pore structure and Hydrogenics builds and tests the stacks as well as the system concepts.

The following quantifiable results were demonstrated:

- Total efficiency =**76%** on HHV basis at a current density of 0.75 A/cm<sup>2</sup> in a 300 cm<sup>2</sup> cell, **82%** for smaller cell
- Materials used suitable for 100°C, tests up to 90°C
- Electrode potential **98%** of initial efficiency over 1100 on/off switching cycles
- Estimate **2,300 €(Nm<sup>3</sup>/h)** plant capacity **stack costs** \$2500 running at 65 bar, **7k€(Nm<sup>3</sup>/h)** for a Hex. S1000 65bar<sub>g</sub> reselyser system
- The gas impurity (O<sub>2</sub> in H<sub>2</sub>) at 30 bar was about the same as for 10 bar in a conventional stack. Similar improvement for H<sub>2</sub> in O<sub>2</sub>. I.e. the electrolyser can be run at a much higher pressure.

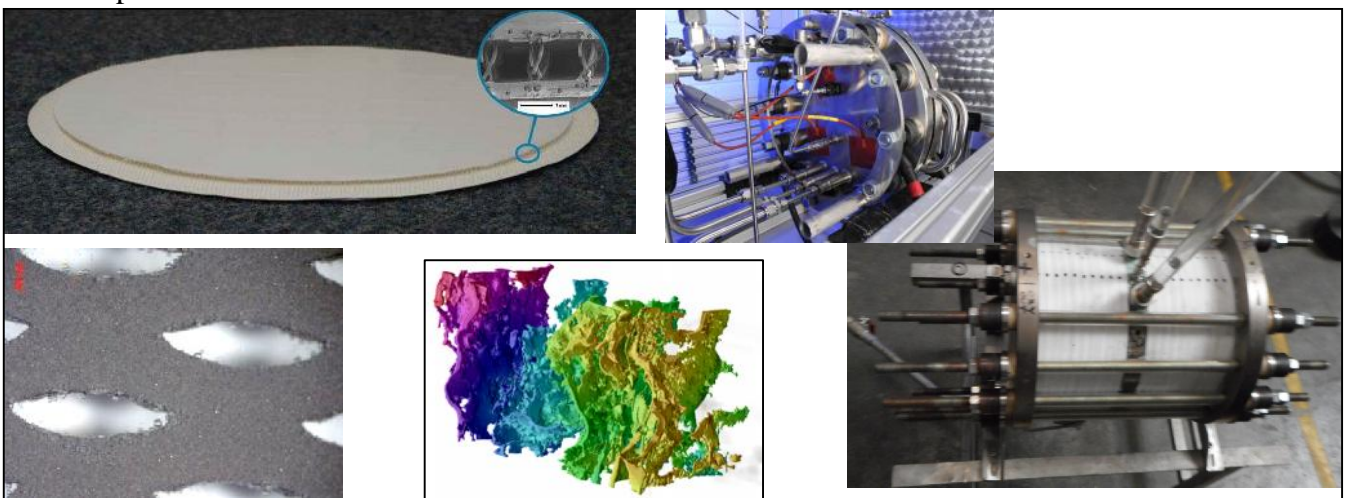

*Project results: e-bypass separator; single cell 300 cm<sup>2</sup>; coated electrode; coating porosity; 10kW stack*

### **Summary description of project context and objectives**

Alkaline water electrolysis for hydrogen production is a well-established technique available commercially in a wide power range. Hydrogen production by electrolysis is increasingly studied as a way to smoothen the fluctuating power output of renewable energy sources in oversupply situations. It is a way to introduce renewable energy into the transport sector and a necessary element of the energy system transformation in several European countries (e.g. Germany or Switzerland). However, some technological issues regarding the coupling of alkaline water electrolysis and Renewable Energy Sources (RES) remain unaddressed. The project aims at improving present electrolyzers for the specifics of direct coupling to fluctuating power operation. Also system costs have to be decreased to reach a low cost but high-efficiency energy conversion.

To address these challenges the project RESElyser - Hydrogen from RES: pressurised alkaline electrolyser with high efficiency and wide operating range - develops and investigates a new alkaline water electrolyser with improved components and a novel concept. A new separator membrane with internal electrolyte circulation (“e-bypass separator”) and an adapted design of the cell to improve mass transfer, especially gas evacuation, is investigated and demonstrated. Intermittent and varying load operation with RES is addressed by improved electrode stability, improved efficiency and a cell concept for increasing the gas purity of hydrogen and oxygen especially at low power operation as well as for high pressure. Also the system architecture is optimized for intermittent operation of the electrolyser. The project partners combine their know how and experience to achieve the project objectives: the project coordinator DLR improves the electrodes, performs single cell tests and works on system concepts, VITO prepares new separator membranes, DTU characterises the electrode pore structure and Hydrogenics builds and tests the stacks as well as the system concepts.

The quantifiable project targets are listed in table 1 compared to the respective values for commercial alkaline electrolyser systems in 2011.

	<b>Target project</b>	<b>State of the art at the beginning of the project</b>
efficiency	Efficiency $\eta > 80\%$ on HHV basis at a current density of $0.75 \text{ A/cm}^2$	Total efficiency $\eta$ approx. 69% on HHV basis in a commercial electrolyser system using partly precious metal electrode coatings and lower current density
operating temperature	up to $100^\circ\text{C}$	approximately $60^\circ\text{C}$
Long-term stability	Retention of $>90\%$ of initial efficiency over at least 1000 on/off switching cycles	High stability in on-off-cycling
System costs	Predicted modular system cost $3,000 \text{ €(Nm}^3/\text{h)}$ plant capacity for the complete system	$5,000 \text{ €(Nm}^3/\text{h)}$ plant capacity for the complete system

*Table 1: Comparison of project targets with state of the art values at beginning of the project for a commercial alkaline electrolyser*

The advanced membrane separator concept, the “e-bypass separator” is one of the key elements required to achieve the technical goals of the project. The “e-by-pass separator” is a three-layer separator composite. It is composed of two adjacent separator layers which are tied together and spaced-apart at the same time. Between the two separator layers the e-by-pass separator will

comprise an integrated electrolyte by-pass-channel. This special separator structure is obtained by impregnating the two outer layers of a 3D spacer fabric with a Zirfon organomineral separator layer. This internal electrolyte channel is used for creating an electrolyte circulation by-pass stream, between and through the two adjacent separator layers. In this by-pass, the electrolyte which is low in dissolved gases, will be forced to flow through the complete surface of the two separator layers. In this way the hydrogen gas that is dissolved in the catholyte compartment as a consequence of pressure is completely prevented from diffusing to the anolyte compartment. This is a major breakthrough in pressurized alkaline water electrolysis especially in high pressure electrolyzers with high solubility of the gases. As a result of this method of operation the impurity of the gases is much lower especially at low current density, pressure and temperature. This e-by-pass separator membrane will be at the center of this project. It is based on a similar concept developed at VITO for submerged membrane bioreactor application. For this application the two membrane layers are based on polyethersulfone microfiltration layers. Here the coating and impregnating technology, as well as the pore size control were already proven. The Zirfon separator developed and established by Vito in the past years has demonstrated very low resistance and high gas separation performance. The production method and the stability of Zirfon separators without an internal layer was improved in the project and advanced to technical scale to obtain reference data for a conventional system with two electrolyte loops. The e-by-pass separator was optimized for the permeability of the two Zirfon separator layers and its electrolyte resistance. The latter will be done by adapting primarily the pore structure of the separator.

Vacuum plasma sprayed (VPS) electrodes for alkaline water electrolysis with very high efficiency were demonstrated at DLR in the 1990's in a 250 cm<sup>2</sup> cell. Use of these electrodes in a 1 kW electrolyser also gave good improvement in the efficiency however the performance reached at small scale could not yet be obtained in the medium scale system. The major advantage of the electrodes was the high long-term voltage stability under intermittent operation even without basic load during standstill time. In this project advances in preparing high surface electrodes by plasma spraying demonstrated in SOFC are transferred to alkaline electrolysis electrodes. The plasma spraying process is developed towards lower cost techniques with further improved performance. Scale-up of the manufacturing process for highly performing electrodes to technical scale electrodes (2500 cm<sup>2</sup>) is performed. Coupled with a small activity to find anode catalyst materials with even lower over potentials and longer lifetime at all relevant potentials during intermittent operation, electrodes of higher efficiency are developed first at 300 cm<sup>2</sup>. A high porosity of the electrodes catalyst layer is important for high efficiency. The porosity depending on the plasma spray parameters as well as the change of porosity during long term operation is analysed by DTU. DTU also performs detailed 3D characterization of the pore network on selected key samples using recently developed techniques transferred from SOFC research.

Test electrolyzers are made available by Hydrogenics with approx. 300 cm<sup>2</sup> cell area for single cell (surface area capability from 300 to 1000 cm<sup>2</sup>) and 10kW. For the new technique employing the e-bypass-separator membrane and using three electrolyte circuits first a single cell test electrolyser is developed. It is then scaled up to 10kW for tests at pressure of 10 bar. The sealing of the 3 compartments at the end of the membrane was a topic to be solved.

The intermediate size and pressure (approx. 10 kW) electrolyser is built within the project with an internal pressure of approx. 10 bar. A high pressure electrolyser demonstrates the quality of the new separator concept at up to 50 bar.

Tests of electrolyzers containing single cells up to 300 cm<sup>2</sup> area are performed mainly at DLR characterising the separator and electrodes development as well as the long term stability. Characterisation of the 10 kW and high pressure system are performed at HYG.

Concepts are investigated for integration of the electrolyser with a renewable energy power source, especially a photovoltaics field or wind power plant. The emphasis in this part of the project is on developing a system with a maximum output of hydrogen using the RES with its fluctuating power supply and also on aspects of a non-grid-connected system.

## Project results

### Membrane Diaphragms

To achieve an electrolyser with decreased gas impurity at low current density and high pressure the concept of the “e-bypass-separator” was realised, the technical fabrication of the separator was developed and it was demonstrated in a single cell and several 10 kW stacks up to 30 bar.

The “e-bypass-separator” is a three-layer composite separator membrane (Figure 1). It is composed of two adjacent separator layers, with an interposed electrolyte bypass-channel, which enables a third stream of fresh electrolyte between and across the separator layers. It is realised by coating the separator layers on a fabric that enforces the layers and keeps them at a distance. Separators were produced to equip three 10kW stacks of 300 cm<sup>2</sup> electrode size. Permeability between 100 l/(h m<sup>2</sup> bar) and 1300 l/(h m<sup>2</sup> bar) was realised covering the theoretical range for all possibly e-bypass system operations. For the system configuration applied in the tests of this project approx. 120 l/(h m<sup>2</sup> bar) is expected to be the right permeability and was delivered. The total thickness of the e-bypass-separators used in the project was 2.6 mm, of which the thickness of each separator layer composed of ZrO<sub>2</sub> and polymeric binder was approx. 0.5 mm. The total resistance of this separator assembly was only about twice that of a single layer commercial separator despite much higher thickness. The total thickness of the e-bypass-separator realised depends on the naked thickness of the available support fabric and on the thickness of the separator layers cast onto.

The gas impurity can be reduced by a factor of 3-4 compared to single layer separator using this separator, i.e. the pressure can be increased by that factor without excessive gas impurity. This opens the door to higher pressure electrolysers.

The separators can be produced up to technical scale. The availability for 2500 cm<sup>2</sup> electrolysers was demonstrated. A cost estimate shows a cost increase compared to single layer separator of 38 % considering material costs and labour.

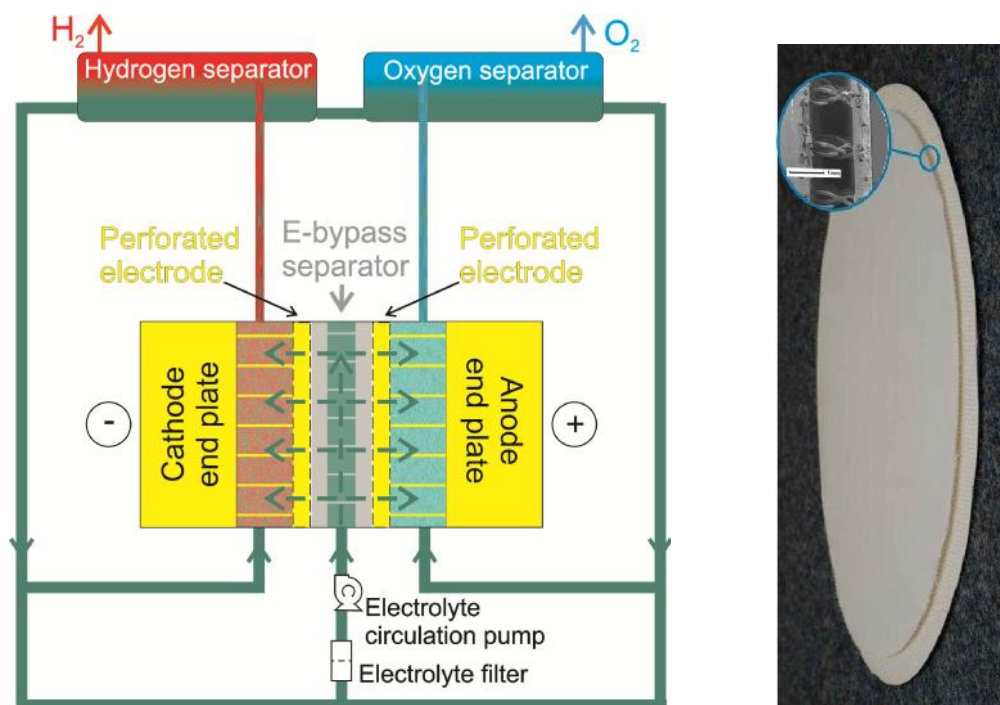

Figure 1: The 3 electrolyte loop concept using an e-bypass-separator; cell/system concept and flows (left); realisation of e-bypass-separator (right). Inset: SEM image of separator cross section showing the separator faces and the fibres linking the faces.



## Electrodes

The objective of electrode development and investigation is to develop and supply highly efficient, low cost electrodes for the electrolyser with a long-term stability in intermittent operation. The electrodes are prepared by plasma spray deposition of catalyst powders at DLR onto plain metal electrodes. The vacuum plasma spray (VPS) process is a process for coating of ceramic and metal layers with adjustable porosity of the layers. It is a well-established industrial process and has been applied at DLR e.g. to prepare the layers for Solid Oxide Fuel Cells. The principle of the process is shown in fig. 2. The powders are transported with a carrier gas into a plasma jet where the particles are melted and accelerated by means of a nozzle. When hitting the surface of a substrate the powders are deposited. Varying the plasma parameters the properties of the layers can be adjusted.

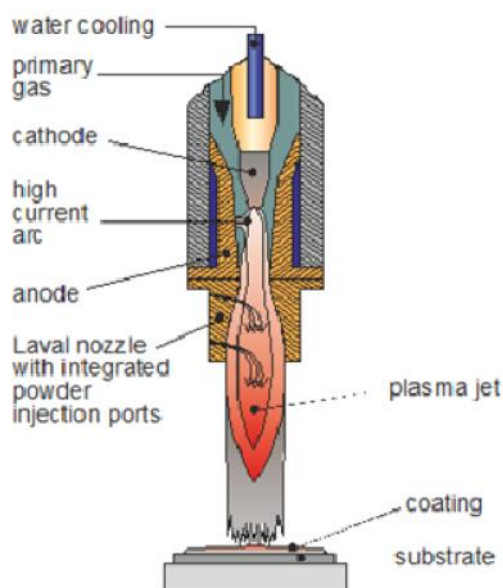

Figure 2: Principle of the vacuum plasma spray process

Electrodes for the electrolyser were prepared by coating plain nickel electrodes with an active layer by using the plasma spray technique. The active layer did not contain any noble metals but only inexpensive material. NiAl alloys with additives are investigated. Before using the electrodes in the electrolyser they are activated by leaching out the Al components in KOH with the addition of a complex former. As a result, the coated layer exhibits a high specific area, the active Raney-nickel electrode surface.

For the cathode NiAl (composition 56:44 wt%) was used as the starting material. A further overpotential reduction can be achieved when mixing the NiAl with active oxides like  $\text{Co}_3\text{O}_4$  with spinell structure or LSCF (Lathanum Strontium Cobalt Iron oxide) with perovskite structure. The mixed valence structure of the oxides improves the catalytic activity while the high surface nickel obtained after activation is responsible for the electric conductivity of the active layer. However, the long term stability of coating layers prepared of oxides and NiAl by plasma spraying still needs further improvement. Therefore most of the investigations in the project were made with cathodes coated with NiAl varying the coating parameters.

For the cathode the **standard material** was commercial NiAlMo (H.C. Starck) with composition 39:44:17 wt% (25:68:7 at%). Alternatively an experimental powder of the composition Ni:Al:Mo 37:46:17wt% with more homogeneous, larger particle size was available. For the stability of electrode coating it turned out to be of advantage to first deposit a thin layer of NiAl and

subsequently a thicker layer of NiAlMo. The coating thickness was approx. 100  $\mu\text{m}$ . Also the plasma spray parameters were adjusted such that a low porosity coating was achieved for good layer stability. There was still enough porosity together with the pores achieved during activation to get a very high surface catalyst.

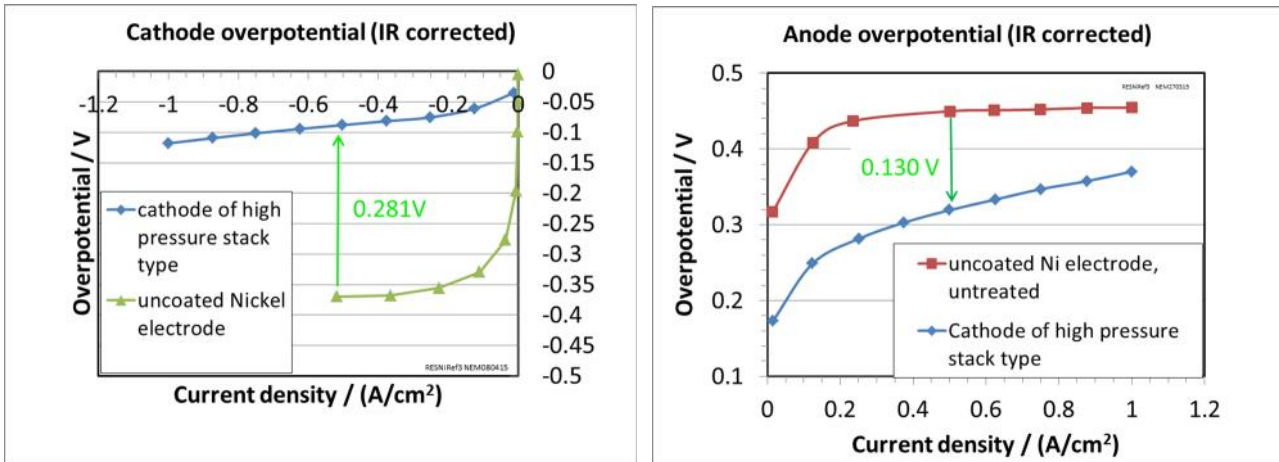

Figure 3: Comparison of coated and uncoated nickel expanded metal sheet electrodes. Half cell measurement of 4  $\text{cm}^2$  electrodes coated with NiAlMo and NiAl intermediate layer for the cathode (left) and NiAl for the anode (right), 70°C, 30 wt.% KOH

Figure 3 shows the overpotentials of the coated electrodes compared to uncoated ones. The overpotential reductions due to the coating as determined in half cell tests in KOH at 70°C were 281 mV for NiAlMo coating for the cathode and 130 mV for NiAl coating for the anode.

The coating procedure also for larger size electrodes (300-2500  $\text{cm}^2$ ) was set up. 300  $\text{cm}^2$  VPS electrodes were tested in a single cell with conventional design, in the single cell with REselyser design and are provided for assembly of several 20-26-cell stacks. Figure 4 shows the current voltage curve of a cell with VPS coated electrodes and e-bypass separator compared to the curve for uncoated electrodes in a conventional cell with single layer commercial separator. An excellent performance of the coated electrodes even at high current density is demonstrated: a cell voltage of 1.965 V at 750  $\text{mA}/\text{cm}^2$  corresponding to an efficiency of 76% (HHV basis) at 80°C and 5 bar<sub>a</sub>.

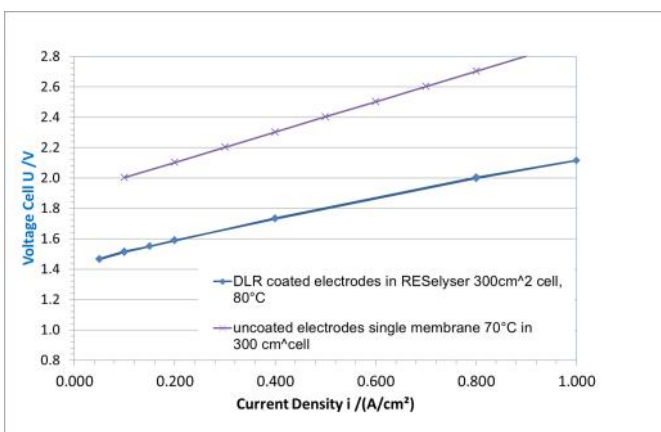

Figure 4: iV-curve of single cell electrolyser with 300  $\text{cm}^2$  electrodes equipped with e-bypass-separator and VPS-coated electrodes

The electrode stability was tested in half cell setup with on-off cycles at 70°C. An optimised cathode was run over a time of 2930 h with 2780 on-off cycles and, for practical reasons, longer periods at OCV at room temperature (Figure 5). The electrode coating did not detach during this

measurement of > 4 months. A first degradation was seen after 87 days with 2449 on-off cycles. The voltage at the end of the experiment was still clearly better than that of uncoated nickel on the first day (orange dot).

An optimized anode was run for a very long time. The operation time of this electrode was 11,937 h (497 days) with a total of 3204 on-off-cycles. Between the beginning and the end of this long period the overpotential of the electrode increased only by 25 mV, i.e. it was very stable.

Considering only the electrode potentials of anode and cathode together an excellent stability was demonstrated: after 1100 on-off cycles 98% of the initial efficiency was retained.

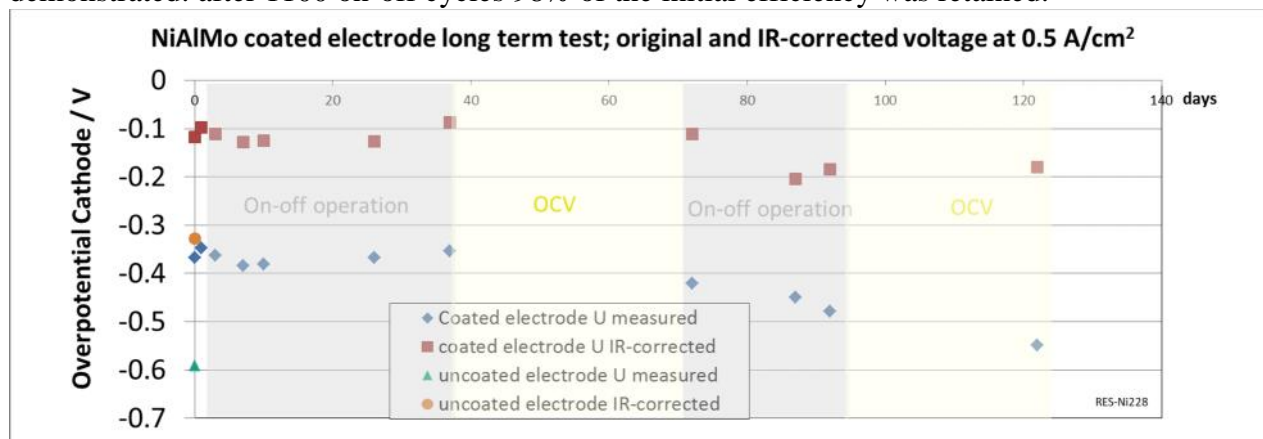

Figure 5: Long-term test of **cathode** in intermittent operation,  $0.5 \text{ A/cm}^2$ ,  $70^\circ\text{C}$ , total time: 2930 h, 2780 on-off cycles (each 15 min). Important coating parameters: powder NiAlMo Sulzer, plasma power 41 kW, plasma gas composition Ar:H<sub>2</sub>:He 65:4:10, vacuum pressure: 70 mbar, layers sprayed: 2 with NiAl, 10 with NiAlMo, scan speed: 400 mm/s, heating:  $400^\circ\text{C}$

Raney Ni raw powders and electrodes produced by VPS were characterised in the as-sprayed, activated and tested conditions by scanning (SEM) and transmission electron microscopy (TEM), X-ray diffraction and Brunauer–Emmett–Teller theory (BET). In general, SEM revealed that the electrode microstructure for both anodes and cathodes in all conditions is a highly heterogeneous and chaotic structure with microstructural features in the range of approximately 50 nm to 20  $\mu\text{m}$  distributed throughout the electrode thickness (see fig. 6). The majority of investigations however, concentrated on the cathode / hydrogen electrode. Cathode surfaces (see fig. 7), where it is expected a significant portion of the hydrogen evolution occurs, also revealed similar microstructural heterogeneity with a high degree of surface roughness and surface porosity.

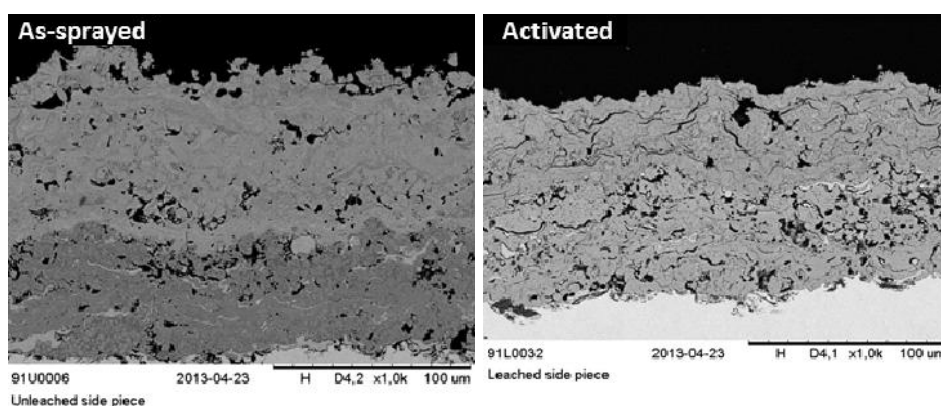

Figure 6: Cross-sectional SEM images of vacuum plasma sprayed Raney Ni hydrogen electrodes in the as-sprayed (left) and activated state (right). The cathode consists of two layers on the Ni substrate: the outer Al-Ni-Mo active surface layer and the inner Al-Ni bonding layer.

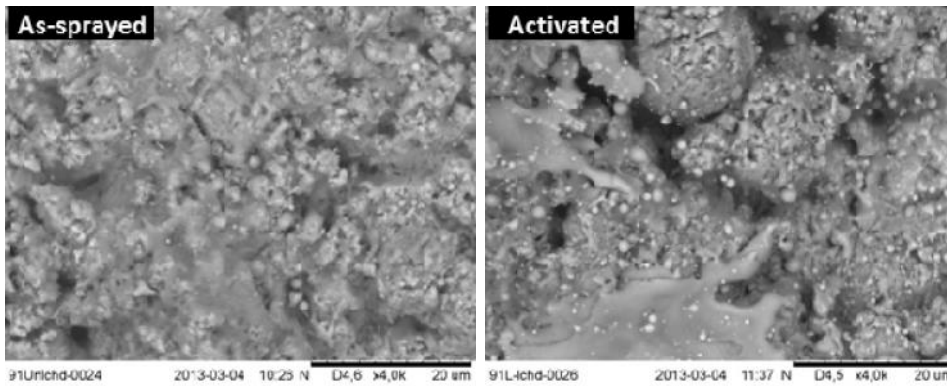

Figure 7: SEM surface images of vacuum plasma sprayed Raney Ni hydrogen electrodes in the as-sprayed (left) and activated state (right).

In the as-sprayed state, the two layer cathode structure is relatively dense on the scale of the electrode thickness where porosity of random shape is associated with regions between the original powder particles that have not completely melted together during the VPS process. Focusing on the Al-Ni-Mo outer and electrochemically active cathode layer it was seen that upon activation, a significant volume fraction of porosity is created at the interfaces between original particles bonded by particle surface melting. Atomic number sensitive SEM imaging revealed that at these interfaces associated with surface melting prior to activation had different average composition and microstructure compared to the corresponding original particle interiors. The selective dissolution of these interfaces during activation is attributed to these structural and compositional differences. The porosity created by this mechanism creates long distorted channels ( $\sim 1\mu\text{m}$  in width) that extend for tens of microns and lay approximately parallel to the electrode surface. The channels in three dimensions have a distorted planar structure as seen in 8 (left). These coarse scale pores are expected to function as escape pathways for hydrogen evolved within the porous cathode. High resolution imaging showed nanometre scale dendritic structures that survive the VPS process correspond to original particle interiors. These are selectively etched dissolving the Al rich phases to leave a highly porous nanometre scale structure consisting mostly of Ni (see 8 (right)). As the nanometre scale dendritic porosity is created by the activation process, it is interconnected to the large distorted planar pores at least after activation. Based on transmitted X-ray intensity the electrode X-ray absorption is a factor of approximately two lower than that calculated for the fully dense alloy suggesting that the total porosity of the cathode is significant.

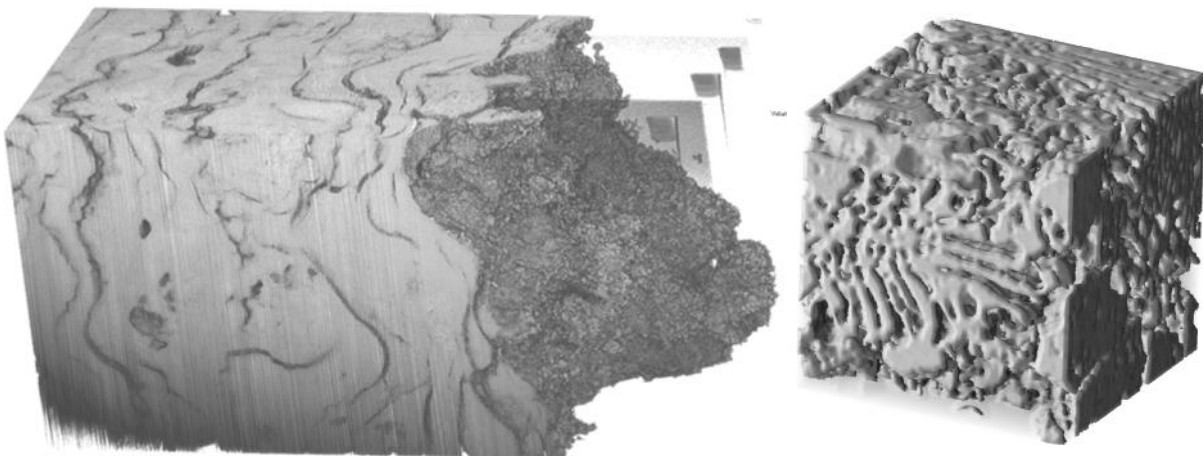

Figure 8: (Left) Three dimensional reconstruction of a tested cathode by focused ion beam tomography revealing surface topography (right side) and coarse scale internal porosity. Volume dimensions  $75 \times 30 \times 45 \mu\text{m}$  (note: top right corner features are artefacts). (Right) High magnification 3D rendering of nanoscale porosity created after activation (cube sides are  $2 \mu\text{m}$ ).

After long term cathode testing, nanometre scale crystallites were observed to grow with "desert rose" crystal morphology on the electrode surface (see Figure ) and on the surfaces of coarse scale internal pores. Bulk XRD of electrode surfaces and TEM diffraction studies of extracted nanocrystallites confirmed that the desert rose was  $\beta$ -Ni(OH)<sub>2</sub>. The extent of  $\beta$ -Ni(OH)<sub>2</sub> formation and growth was found to primarily correlate to electrolysis duration and that water storage of activated electrodes and powders also lead to the nucleation and growth of desert rose structures to a lesser degree. From the available electrode test and post mortem microscopy data it is not possible to conclude under which conditions the  $\beta$ -Ni(OH)<sub>2</sub> formation growth kinetics are greatest due to the complex test history that emulates intermittent electrode operation in a renewable energy scenario. It is not known if the growth is associated with hydrogen evolution under current or when the electrode is passive at open circuit voltage. According to pure Nickel Pourbaix diagrams available in the literature  $\beta$ -Ni(OH)<sub>2</sub> is stable over a wide range of pH in highly basic solutions adjacent to but at lower pH than the operation conditions of the electrode. This suggests that variations in pH are required to induce the formation of  $\beta$ -Ni(OH)<sub>2</sub>. However, how the Al and Mo of the electrode alloy affects the stability regions of the Pourbaix diagram is not known.

Presently the electrochemical performance implications of nanometre scale  $\beta$ -Ni(OH)<sub>2</sub> formation on hydrogen electrodes has not been fully ascertained as its formation leads to a significant increase in available surface area for hydrogen evolution, however the electrical conductivity of this morphology is unknown and its formation can lead to the filling of the coarse pores with crystals potentially creating an impermeable barrier to hydrogen evolution. It is concluded that the  $\beta$ -Ni(OH)<sub>2</sub> formation has the potential to become a serious cathode degradation mechanism and further research in the form of targeted electrochemical testing is recommended to quantify formation rates and safe cathode operational parameters.

The coarse and fine scale porosity in short and long term tested cathodes was visualised by focused ion beam tomography (see 8). A statistically representative quantification of the coarse scale porosity in terms of microstructural parameters was not possible as the reconstructed volumes were smaller than the scale of coarse porosity. However, on the assumption of available representative data, methodologies for quantifying porous microstructure pathways for evolved hydrogen escape from the electrode interior were developed in terms of distances to the electrode free surface and identification of bottlenecks. These parameters in addition to classical 3D microstructure descriptors such as specific surface area; pore channel size distributions etc. should be useful in the comparison of various electrodes as a function of operation conditions.



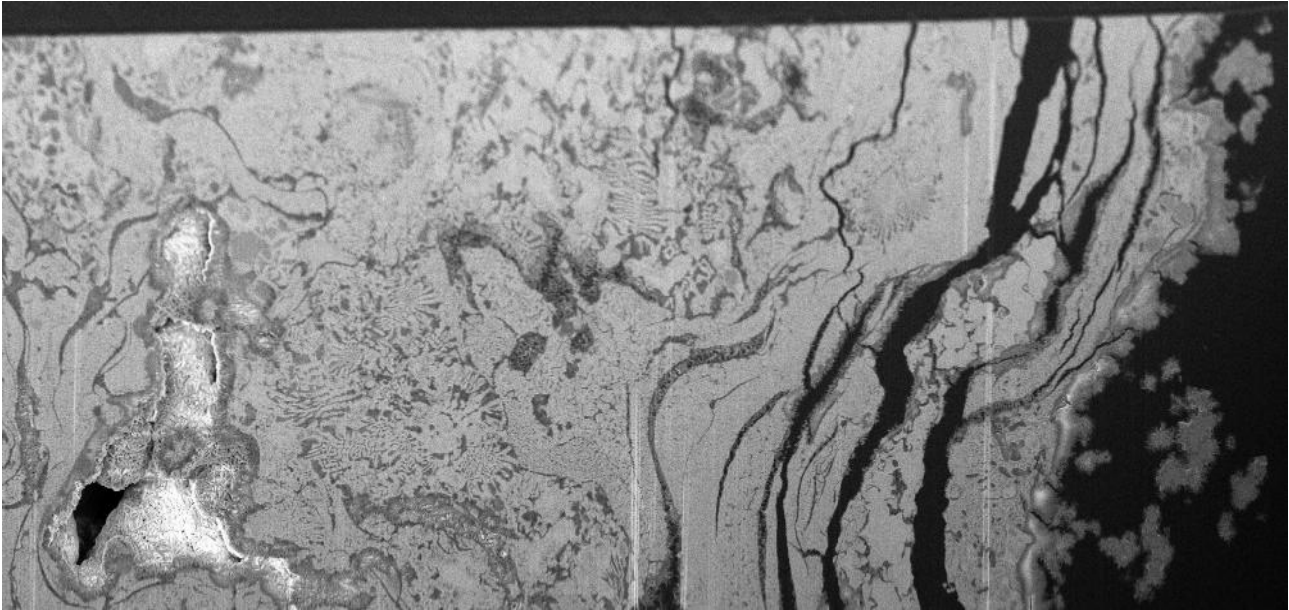

*Figure 9: Nanometre scale desert rose morphology S-Ni(OH)<sub>2</sub> formed on cathode surfaces after short term testing. Formation can be seen on the cathode free surface (right) and on internal pore surfaces that can be located deep within the electrode (image width 50 μm). The higher magnification inset reveals the S-Ni(OH)<sub>2</sub> as seen from the electrode free surface of a long term tested cathode.*

A cost analysis of the coating process steps and materials was made. Assuming an industrial production line based on today's technique the dominant cost is the cost of the substrate (today nickel expanded metal with a thickness of 0.5 mm). Material costs of the coating are approx. 25% of the substrate, labour and machine costs in an industrial process even less. Therefore the next step should be to find an electrodes substrate of lower costs.

## **Cell and Electrolyser Concept**

To be able to characterize the materials and operating principles of this project in a close to commercial size electrolyser a design with 300 cm<sup>2</sup> electrodes was adapted to integrate the double layer e-bypass separator. This design was realized in a single cell (fig. 11 left) for extended tests of materials, operating parameters and operating concepts, as a 20 cell stack used up to 10 bar (fig. 11 right) and in a high pressure, 24 cell stack that can operate up to 50 bar.

The e-bypass-separator was accommodated in the cell with an the additional structural ring. The double layer separator with its sides being cut open is thoroughly inserted in-between the separator faces. An internal channel supplies the KOH into the bypass volume. In the course of the project, different ways of sealing the separate electrolyte compartments around to accommodate the e-bypass-separator have been tested.

One concept was to fix the e-bypass-separator to the structure ring by glueing (fig. 10). The glue line had to be sealing to a differential pressure up to 1 bar, as well. This could be achieved but it was not easy to do and quality control difficult. The structure ring could not be reused and the long term stability of the glue was doubtful. So this was not considered a suitable solution neither for laboratory testing of many different materials nor for a commercial stack.

For another construction of the e-bypass-separator integration with the structure ring a seal was necessary that could guarantee gas impermeability of an underlying profile containing steps. Graphite sealing rings promised both good sealing and the added value of individual cell voltage

monitoring. However, this was not a wise choice. The addition of conductive surfaces in both anolyte and catholyte loops, led to extra gas contamination by parasitic reactions (leakage currents).

The following iterations went via thin Teflon gaskets (creeping issues) to Gylon (stable but expensive) to pre-extruded and thicker stabilized Teflon seals in the final stack and a similar construction for the single cell. The proof of concept of this seal was first demonstrated on the inner parts of a two-cell high pressure stack, before up-scaling.

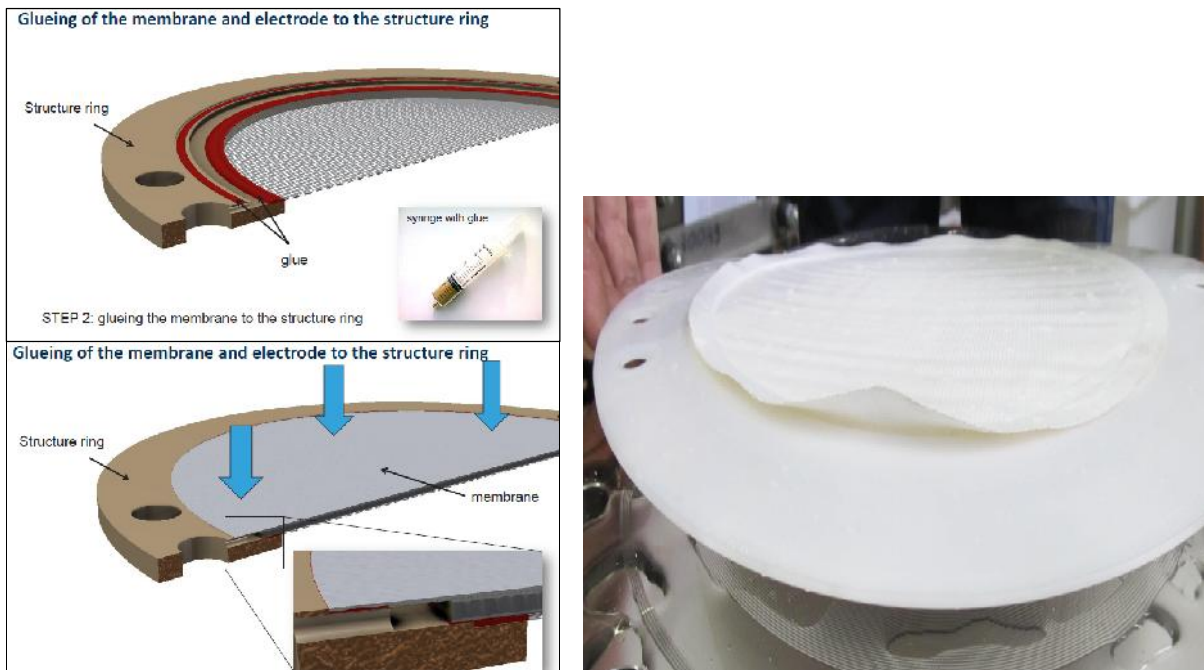

Figure 10: Left: assembly steps for the cell with glue concept. Right: Compressive seal concept, mounting concept where the additional ring for the bypass electrolyte loop is in place in between the skin layers of the double sided separator.

The plasma sprayed catalytic layers, need to be activated by caustic leaching, i.e. removal of the non-intermetallic Al in the alloy. During the construction phase, there were three possibilities mentioned for the electrode activation action:

- In situ activation
- In stack activation
- Process controlled electrode activation: This was finally preferred. Before stack assembly the electrodes were activated in a dedicated activation bath, allowing a good control of the lye with the electrodes and heating of the solution to control the leaching process. This has the advantage of a controlled activation process. However care must be taken with the activated electrodes to avoid air access (keep them wet because of deactivation and strong heating with air) and mechanical impact during stack assembly.



*Figure 11: Single cell with 300 cm<sup>2</sup> electrodes size for testing the e-bypass-separator concept (left); 20 cell stack 10 kW range equipped with e-bypass-separators and VPS-coated electrodes (right)*

The test setup for the RESElyser stacks (fig. 12) differs in some components from a conventional teststand. An extra KOH loop for irrigating the bypass in the middle of the separator is needed. This flow is maintained by a KOH pump that needs to deliver a small overpressure on the inner side of the separator. The resulting electrolyte flow to anolyte and catholyte depends on the separator permeability and the total active surface of the cells. Initial pressure spikes of the compressor were leveled to avoid destruction of the separator.

Because of the relatively small amount of dissipated heat in the cell stack, an additional heating element needed to be installed in the loop so that the stack could be operated at 60°C or higher.

I was assumed that in order for the e-bypass set-up to work, it is very important that the KOH solution that is pumped in the inner compartment of the separator is properly degassed. A Liqui Cell degasser evacuating the liquid through a hydrophobic membrane, was installed. However later tests showed that this evacuation was not seen as positive effect on the gas impurity. With the pressure operation window of this available degasser being limited, it was not used for high pressure tests.

The gas liquid separators are selected comparatively large to improve the degassing of KOH before being recirculated.



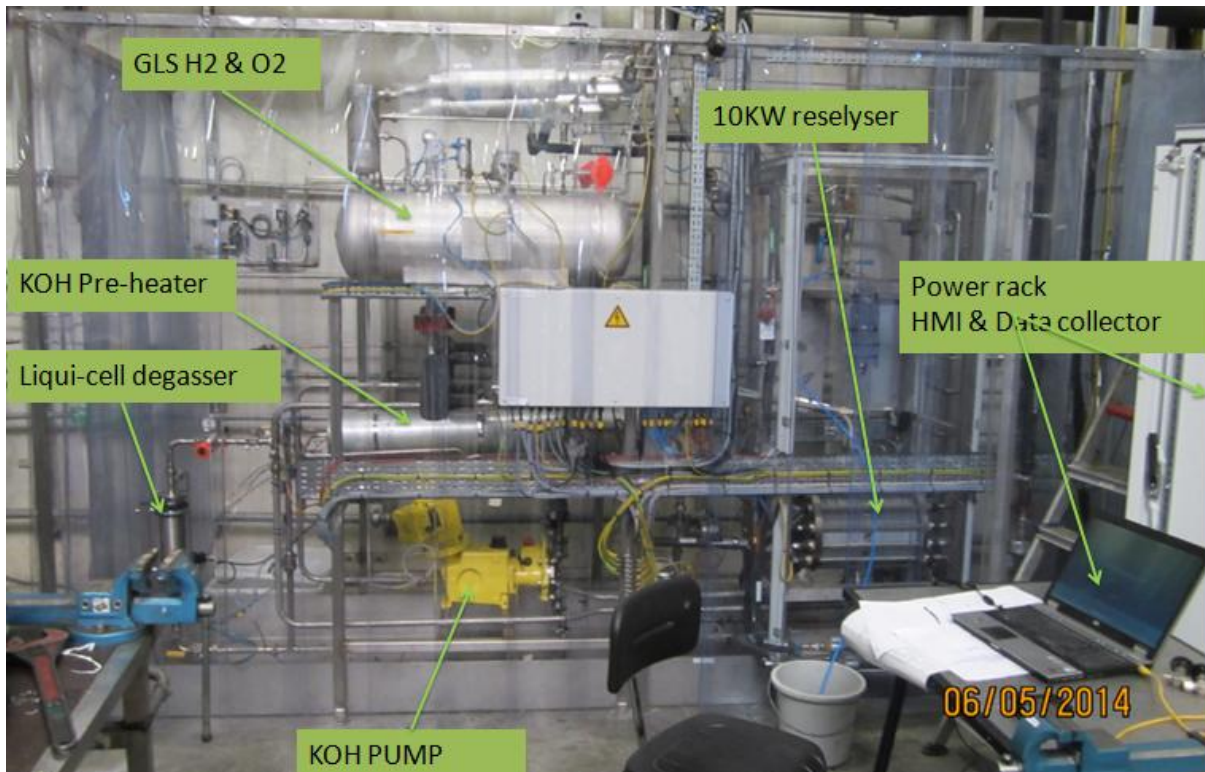

Figure 12: first prototype of an e-bypass electrolyser, housed in a modified teststand for single separator stacks.

A high pressure (HP) stack with new design is set up. The new design was submitted for patent. It allows to use only minimal amount of parts designed for high pressure. Most of the parts, especially those of more delicate shape, will only experience a small pressure difference allowing the use of low cost materials.

The stack is designed for a pressure of 65 bar, the leak-tightness of the stack was measured at 97.5 bar, This pressure is suited for a power-to-gas application where  $H_2$  would be directly injected in the natural gas transmission grid, typically operating at 55-60 bar. Operation was demonstrated up to 30 bar in the project. In order to have a BOP that can operate at elevated pressure but still be compared to Hydrogenics' baseline product of 25 bar, a design of 35 barg has been put in place. Component selection up to 35 barg has still proven to be cost effective for the given design. Stack and system meet the applicable hydrogen safety standards.

The only drawback that impedes alkaline water electrolyser's possibilities linking to RES, is the narrow operational window. This is linked to the intrinsic property of an alkaline separator of it being porous on a micrometer scale. This is needed for the ionic conductivity. This intrinsic porosity is the root cause of the cross contamination of the reaction products, requiring a certain dilution by the desired gas in order to avoid explosive mixtures. This minimal dilution is achieved at an operational point of 20-30% of the nominal current density per stack.

In RESeleyser, this cross-contamination is largely diminished by the convective flow through the e-bypass-separator electrolyte loop, counteracting the diffusional (pressure driven) mass transport through the membrane separator.

Additionally the operational range can be extend by dividing the electrolyser into several packages that can be operated or kept without current depending on the power input. This can be done on system level, by excluding stacks from operation in a multi-stack generator or on stack level, by subdividing the electrical feed points over the stack. Another benefit of this is that the maximum

power point of the electrolyser can be tuned and adapted to the power source especially if direct connection to a solar field without a DC-DC converted is considered. Operating parts of the electrolyser at high power density and therefore at a low gas impurity while other parts are at open cell voltage should reduce gas impurities. An important prerequisite for such partial operation of the stack is that the electrodes are highly stable to degradation at OCV or any potential the electrode might arbitrarily reach.

Another point to be considered is a strategy for stack temperature. The higher the stack temperature the lower are the losses due to electrolyte resistance and electrode overpotentials. Therefore it is desirable to heat the stack quickly to its operating temperature. Also here a splitting of the system in several partial electrolysers is useful. Some electrolysers are in frequent operation keeping them at or close to operating temperature. They therefore have low losses. Only at high power the other stacks are started and heated up quickly due to the high power supply. This has to be well implemented in the system control.

Subdividing the stack into several parts is not experimentally investigated in this project.

Cost calculations for the electrolyser stack were performed for 300 cm<sup>2</sup>, 1000 cm<sup>2</sup> and 2500 cm<sup>2</sup> cell area stacks alternatives. Basis for the calculations are material costs estimated for 150 electrolysers per year. It is concluded that there is a possible market for the RESelyser concept in the range of medium flows (up to ca. 100Nm<sup>3</sup>/hr, or 200 kg/day), based on the S1000 platform when it can be operated at 65 bar. It is then cost competitive with conventional AWE in series with a hydrogen compressing unit. At the higher operating pressure of 200 bar, the window of opportunity gets narrower, since larger hardware investments will be needed. RESelyser offers extra advantages in terms of footprint and expected reliability. The service interval of the compressor is the shortest within the electrolyser system. Therefore eliminating the compressor from the system increases service intervals and thus the reliability.

## Small Scale and Technical Scale Electrolyser Tests

Electrolysers with materials from the project were tested with a cell area of 300 cm<sup>2</sup> as single cell and 20-24 cell stacks.

Figure 13 shows a comparison of the current voltage curves for the same operating parameters for single and e-bypass separator single cells as well as uncoated and coated electrodes. The curves for conventional cell were recorded at Hydrogenics in a cell similar to that of the RESelyser project with a commercial Zirfon separator. The coated electrodes do not agree in all coating parameters; however, as it was shown in half cell tests at least the cathodes do not differ too much in performance depending on the coating parameters.

The level of performance clearly depends on the coating of the electrodes, not on the number of separators. The cell voltage reduction from uncoated nickel electrodes to VPS coated ones is in the range of 0.65 V. Comparing the curves for the uncoated nickel electrodes a much higher slope of the characteristics is observed for the e-bypass-separator cell that could be due to a higher ohmic resistance. On the other hand for the coated electrodes the slope for the e-bypass-separator cell is even lower than for the single separator cell. This is surprising. One would expect that due to the longer distance between electrodes and therefore some higher resistance of the e-bypass-separator the slope for the e-bypass cell is somewhat higher. The difference seen here for the uncoated electrodes is higher than expected from the resistance measurements, the difference for the coated electrodes is too small. The larger difference for the uncoated electrodes can possibly be explained by some additional contact resistances because the “pre-electrode” connecting the electrode to the end plate cannot be pressed as strongly as for a single separator because the e-bypass-separator is

more compressible. The opposite order of slopes for the curves with coated electrodes can be due to the fact that the slope is not only due to the ohmic resistance of separator/KOH or electrical contact but also the activity of the electrode has an influence on the slope. The fact that the electrode coatings were not the same could be the reason due to different activity.

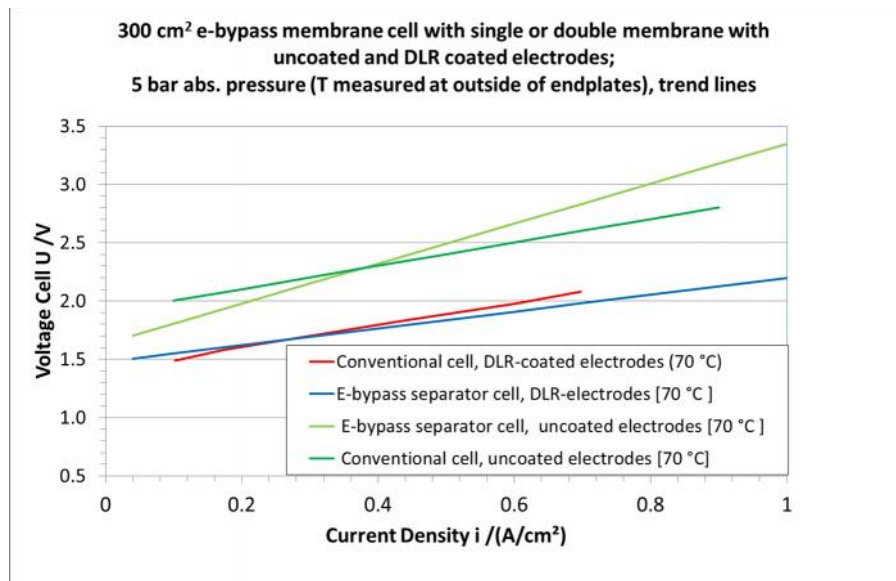

Figure 13: current voltage curves at 70°C for single cells with uncoated and VPS coated electrodes and conventional single separator vs. e-bypass-separator concept.

The direction of the KOH flows in the cell and their influence on the gas impurity was tested. Figure 14 bottom right shows the system with 3 compartment cell, gas separators and the KOH lines with valves that can be switched to study the influence of certain configurations. As can be seen the gas impurity level is quite low in all configurations.

Measurement 1 and 2 are the standard RESelyser operation: non-degassed KOH is taken from both gas separators and pumped into the middle. At the same time there is passive KOH circulation in anode and cathode circuit. KOH level equilibration between gas separators is possible. It can be seen that the reproducibility of the test result is poor.

Complete degassing of the KOH supplied into the middle compartment (3 and 4) did not give an advantage to gas impurity. So it seems that this is not necessary. Other options tested were to take the KOH pumped into the middle of the cell either from the oxygen or the hydrogen gas separator and to open or close the connection of KOH between the gas separators that allows for KOH level and pressure equilibration. Flow configurations without passive cycling of KOH through anode and cathode are not considered a technical option because the pumped flow through the middle of the membrane is too low to provide cooling in high power operation.

Measurement 4 was like 3 but the KOH level equilibration is closed. By pressure control of the anode and cathode side the differential pressure between anode and cathode is kept below 10 mbar. The impurities are a little smaller than for experiment 3 possibly because the exchange of KOH with gases dissolved and microbubbles between the gas separators is no longer possible.

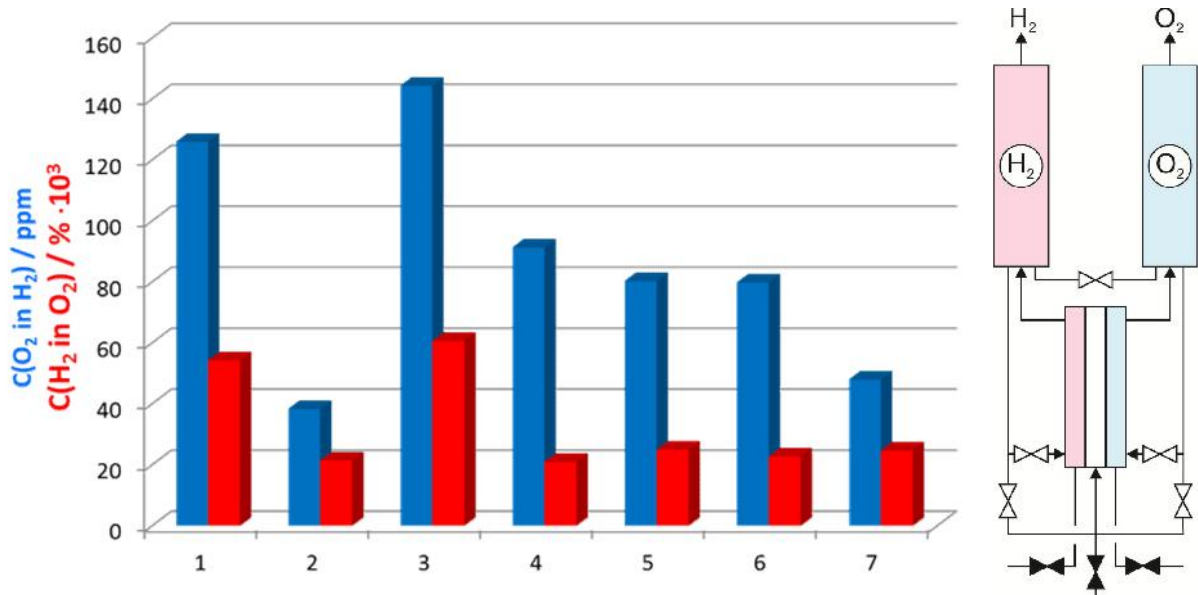
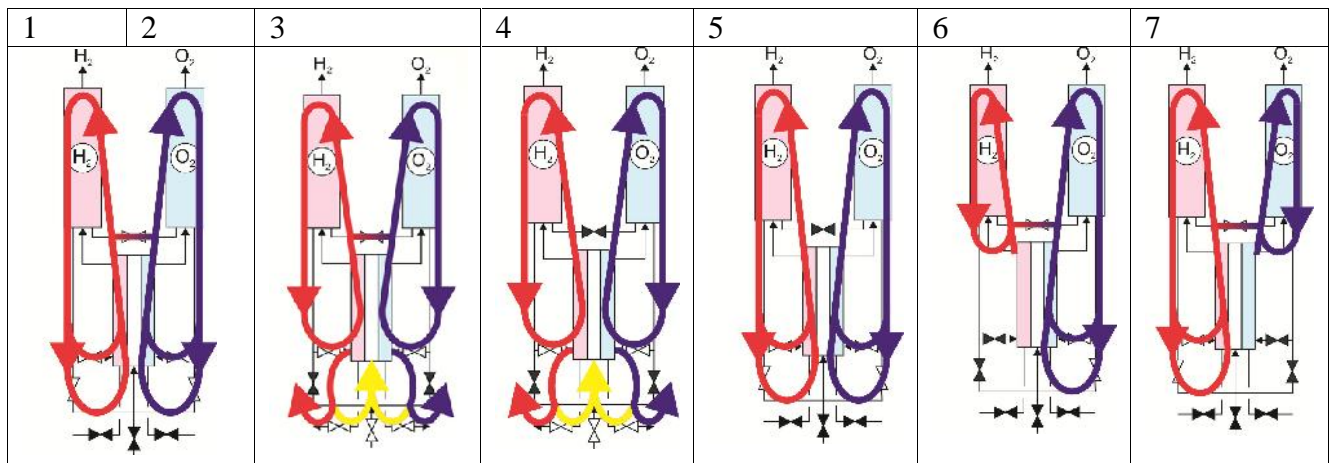

Figure 14: Flow configurations and measured gas impurities. Cell-Temperature: 70 °C, KOH-Flowrate: 15 ml/min, KOH-Temperature (Tank): 40 °C, Current: 45 A (150 mA/cm<sup>2</sup>), cell with e-bypass-separator and DLR coated electrodes. Bottom right: the system with valves; top: flow configuration number 1-7, bottom left: measured gas impurities for flow configuration 1-7.

Lowest gas impurities achieved at 0.150 A/cm <sup>2</sup> , 70°C:	O <sub>2</sub> in H <sub>2</sub> /ppm	H <sub>2</sub> in O <sub>2</sub> /ppm
With single separator, measurement Hydrogenics (D3.1), uncoated electrodes:	2100	2900
With single separator, measurement DLR, coated electrodes:	77	980
With e-bypass-separator, coated electrodes , first cell	63	250
With e-bypass-separator, coated electrodes , last cell :	48	247

## *Table 2 Gas impurities for different cells*

Table 2 shows a comparison of single cell and e-bypass-separator cell measurements performed in the project. It can be seen that the hydrogen in oxygen impurity was reduced by at least a factor of 4 in the single cell due to the e-bypass-separator. The oxygen in hydrogen impurity is reduced to approximately 72%. I.e. there is a clear advantage using the e-bypass-separator, the cell can be operated at higher pressure and/or lower current density before reaching the limiting gas concentration.

What can also be seen from these measurements is that the **gas impurity** in an electrolyser **depends on many more factors** than what separator is used. The flow of KOH with dissolved gases through the single layer separator must be kept low by carefully controlling the differential pressure. Also for all systems there is a flow of KOH between the two gas separators (see Fig. 1 top dark green line); this KOH usually contains not only dissolved gases but also microbubbles of gases, depending on the quality of the gas separator. If the gas separator is larger leaving more time for outgassing and if gas bubbles condensation sites are contained like Raschig rings the degassing will be much better and the impurity coming in on this way will be smaller. One could also think of integrating a Zirfon-like separator between the gas separators that will prevent the microbubbles from passing. For better understanding to allow for good system control in the future, flow measurements at the test station and simulation calculations would be necessary. Another reason for improved gas quality could be the use of high activity electrodes; at these electrodes the impurities diffusing through the separator can react to water that not so much impurity reaches the gas phase. Taking good care of these points also for a single layer separator the gas quality can be quite good.

Current voltage and gas impurity measurements were made on the 24 cell high power stack. It is shown in fig.15 that the Reselyser HP cell stack displays inferior cell voltage for any given current density and thus higher efficiency. There is a minor effect of operational pressure. For comparison the iV-performance of a commercial 1000 cm<sup>2</sup> stack (S1000) is shown, containing not only low cost materials electrodes. There is a clear cell voltage reduction to this for the RESelyser stack with VPS electrodes and e-bypass-separators.

The cell potential of 1.85V at 0.44A/cm<sup>2</sup> corresponds to a HHV based efficiency of about 82%.

It is remarkable that despite the spacing between the electrodes e-bypass membrane, increased to 3mm instead of the 500 µm in a single membrane stack, the cell voltage increase in the IR-drop of the HP is that low. This means that the catalytic activity largely compensates this extra potential drop, calculated at 300 mV at the highest current density. Figure 15 shows the extrapolation towards a single membrane spacing.

As originally anticipated, the cross contamination of both produced gasses in a stack based on the reselyser e-bypass membrane is reduced (figures 16 and 17). The hydrogen contamination (fig. 16) compares to a single membrane stack operated at 25bar S1000 despite the 5 bar extra pressure. This is the less critical one of the cross contamination since the oxygen contamination is catalytically removed in a subsequent process step.



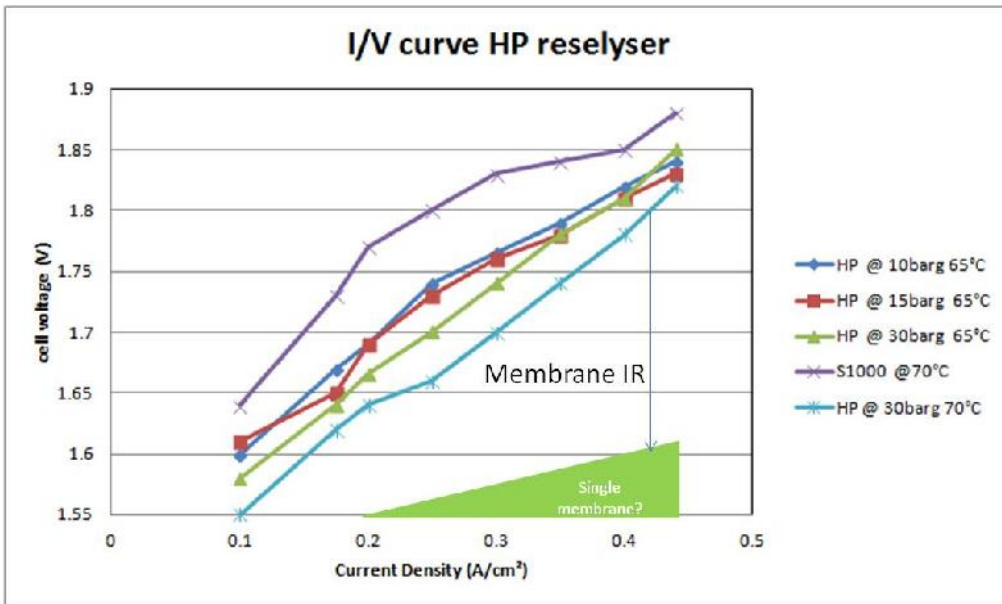

Figure 15: Projection of the expected cell voltage when using plasma sprayed and activated electrodes in a single membrane electrolyser with a smaller IR-drop.

The safety critical hydrogen contamination in the oxygen stream (fig. 17) is at a very low level in the HP e-bypass stack. At moderate pressures of 10-15 bar the value is nearly independent of the current density, indicating that there is a kind of base load that is inherent in the circulated flow. At the higher test pressure of 30 bar, the stack is well below the installed rejection limit for single membrane stacks at 25 bar, where a failure rate of 50% of newly constructed stacks is faced.

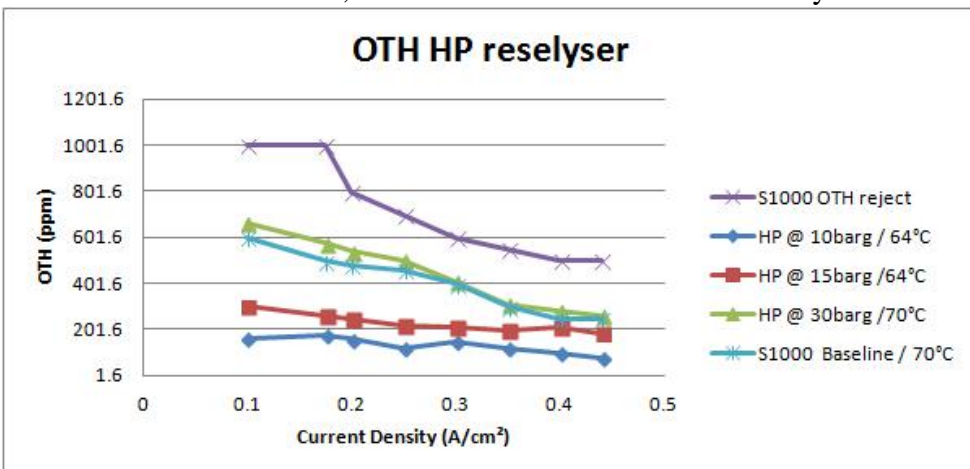

Figure.16: Oxygen content of the raw hydrogen stream of the HP stack at different pressures compared to the single membrane baseline (25 bar).

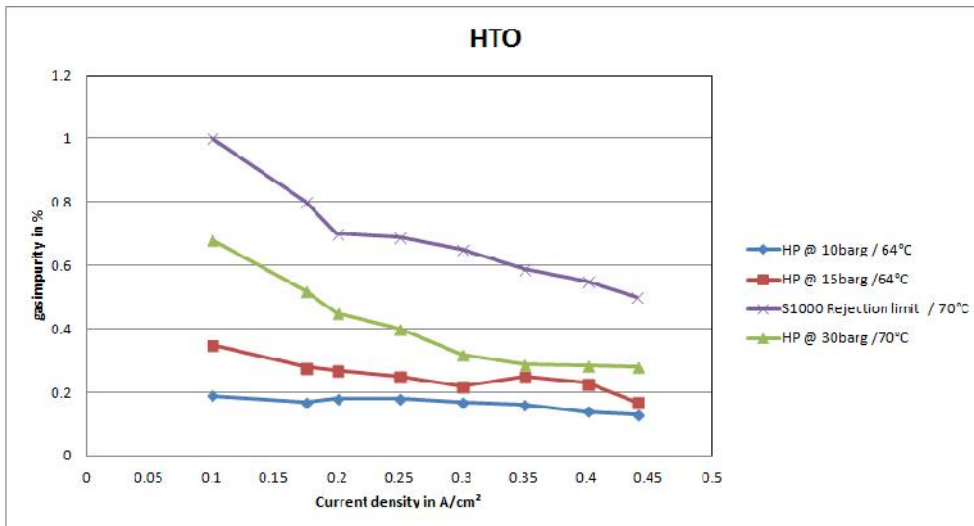

Figure 17: Hydrogen content of the raw oxygen stream of the HP stack at different pressures compared to the single membrane baseline.

When projecting the expected oxygen impurity caused by hydrogen cross-over as a function of pressure (Fig. 18), the current separator properties should allow operation to about 120bar, without making any changes to the skin layers' permeability.

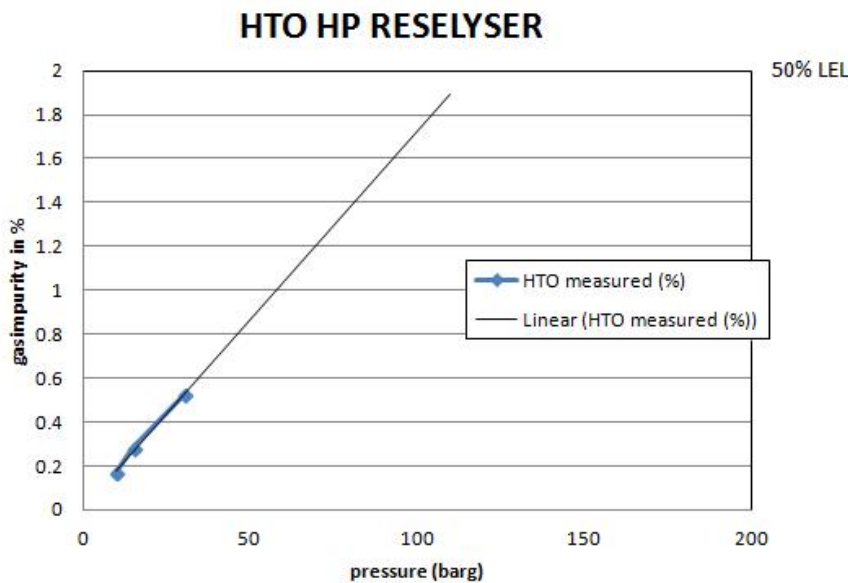

Figure 18: Extrapolated oxygen purity as a function of operating pressure.

Since the second prototype was designed and constructed according to the legal and Hydrogenics' internal standards, this unit was suited for unattended testing. The cycling stress test was performed as follows:

- ON/OFF regime @ 30 barg, 70°C
- 1min ON and 1min OFF.
- 1800 cycles per test.

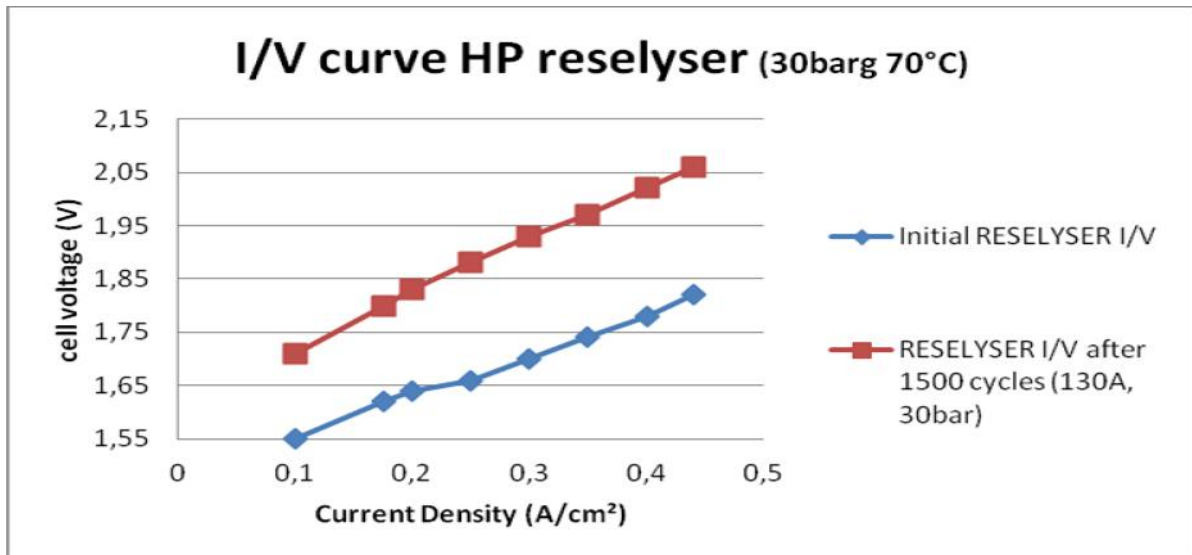

Figure 19: current-voltage curves of the e-bypass stack before and after cycling (1500 on/off at 30 bar and 0.433A/cm²)

The very good current-voltage that was found over the entire current ranges at the beginning of life of the cell stack, is found to be degraded.

The HHV based efficiency drops from 81% to 72% on stack level over 36% of the amount of assumed total life cycles. This degradation compares to 90% of the life span of a normal single membrane stack.

The relatively large voltage degradation is linked to a degradation of the coating; residues and debris was found in the electrolyte loops after the duration tests. The coating adhesion and/or its mechanical integrity needs to be improved before commercial use. In single cell tests it was seen that the anode coating stability was not sufficient and the coating was completely lost after longer term cell testing while the cathode coating remained stable.

## Electrolyser system aspects and concept development for autonomous electrolyser – solar/wind energy system

Aspects of electrolyser systems and BOP affected by highly fluctuating power input as well as concepts for integration of the electrolyser with a renewable energy power source, especially a photovoltaics field or wind power plant, are investigated. The emphasis in this part of the project is on developing a system with a maximum output of hydrogen using the RES with its fluctuating power supply and also on aspects of a non-grid-connected system. Information for this work package was taken from the partner's experience and previous projects as well as from a literature study.

It is commonly believed that traditional single separator alkaline water electrolyzers (AWE) are not suited for intermittent operation, often they are described as being slow in functional. While this holds for commercial MW-scale systems, it needs some nuance for modern pressurized electrolyzers in the sub-MW range. Alkaline electrolyzers can be limited in reaction time, because they are designed to deliver hydrogen at a certain pressure, not to take up power. This aspect has been tackled by making the operation set-point controlled by power uptake rather than by a pressure set-point. Response time is more of a system (BOP) and power conditioning topic, than an intrinsic property of AWE. I.e. by using an improved control of the system it can be made a lot more flexible and faster.



Furthermore there are recent advances that have been integrated in electrolyser systems or can be integrated to make them better adapted to fluctuating power or towards cost reduction. These are e.g.:

- Modular electrolyser consisting of multiple stacks sharing part of the BOP. The modules can be either switched off or operated close to nominal power.
- High pressure electrolyser system. No compressor necessary or compressor with less stages reducing the CAPEX, the footprint and the service costs and increasing the system availability due to longer service intervals.
- Adapt IV-characteristics to IV-characteristics of renewable power supply (solar field..). By better wiring of a solar field and the right selection of an electrolyser system the DC power characteristics can be adapted and less losses in power transformers is experienced.
- Reduction of number of components by higher system component integration. Components specially developed for electrolyser are used instead of off-the-shelf components. Still the market volume of electrolysers is too small and the diversity of system components for the different electrolysers suppliers is too high to use this option extensively in a commercial way.
- A better and fast control of the electrolyser pressures and flows will reduce the internal pressure changes induced by power changes. Also the flows of gas-containing KOH that make a major contribution to gas impurity can be reduced.
- The efficiency of the systems can be reduced by reduced power consumption of BOP components e.g. cooling. A good control strategy, adapted components and a good understanding of the system based on system modelling can bring further improvements. Along with this goes a strategy for power control of BOP components in fluctuating operation that need not always be “on” respectively at maximum power.
- Clear separation of power supply to the electrolyser process and to supply of the BOP. By this way highly efficient rectifiers can be used the BOP power supply being much lower power and at a different voltage level.
- Integration of an independent connecting module to transfer waste heat power to an external user. If any application for heat at a temperature level of approximately 50-60°C or by using a heat pump also at higher temperature can be integrated in the electrolyser, an extra benefit will be available.
- Consequent collection of condensate and purification for reuse in the electrolyte circuit. Especially for remote area or hot country applications but also to reduce the operating costs the loss of water must be kept low.
- No regular inertisation of the hydrogen circuit before start of operation. This is already realised for most systems today. However keeping the electrolyser pressurised and with the gases inside for a long time requires good control and system design. Doing so the gas loss due to impurities can be minimised.
- Modularising systems and using premanufactured modules reduced the costs.
- Highly integrated, container- based solutions reduce the footprint.

Integrating these improvements modern electrolysers are not limited in their possibilities of dynamical or intermittent operation. What still has to be done for a more wide-spread market entry is:

- Efficiency increase
- CAPEX , OPEX cost reduction
- Extension of current density operating range to lower and higher range

These topics were addressed with the developments in the RESelyser project.

One option for CAPEX reduction is transfer from manual or semi-automatic production as of today to serial production. By investing into automatic production an increase of the turnover by 50% can

be achieved with an increase of the cross margin by 40%. To achieve this increase in turnover and cross margin by full automation, however, the sales network, customer and market intelligence must be there from the start. Every one of four consecutive years a significant part of the market needs to be conquered. The total market at this point is estimated to be at 100 million €(world wide).

For an electrolyser coupled to a photovoltaics field different modes of coupling were investigated in a previous project <sup>1</sup> and were revised now (Figure 20). Such an application could be relevant in rural or remote areas in countries with high insolation where the grid connection is of low capacity.

**Direct Connection concept:** The PV-field is directly connected to the electrolyser.

As in this case PV-field and electrolyser have only discrete fixed operation points, the layout of the PV-field has to be designed carefully in order to match the electrolyser characteristic in such a way that it produces the lowest possible losses. Three different voltage levels have been examined in direct coupled operation with an electrolyser.

**Full DC/DC concept:** The PV-field is connected to a low-setting DC/DC converter. The field output voltage can be adapted continuously in a wide range.

Two parallel operating buck converters (impedance coupled, choke-coil self-inductive) of the power conditioning unit transform the input power continuously (input voltage band 20-100 V DC) to the demand of the connected electrolyser (output voltage  $48 \pm 10$  V). At the same time, they track the PV-field at its MPP by varying their input voltage and input current. This MPP tracking can be done either internally by the converters or by an external program code. Optionally, a fixed input voltage can be adjusted to do experiments for which no MPP tracking is desired. The two basic loss mechanisms (internal power consumption, conversion losses) are summarized in the converter efficiency (output power/input power).

Three boundary conditions can restrict the operability of DC/DC-converters:

A minimum retaining current is necessary at start-up in order to perform the internal power part check and, thus, must be overcome at startup.

The converters cannot track at MPP below a minimum insolation of e.g.  $50 \text{ W/m}^2$  because the I-V characteristic is then too flat for detection.

The MPP tracking cannot follow fast fluctuations of solar insolation because sometimes the control speed is restricted for technical reasons to a given voltage change speed.

**Bypass DC/DC concept:** The PV-field is subdivided into a main field (MF) and a bypass field (BF), the latter connected to a high-setting DC/DC converter. MF and converter output are connected in parallel to the electrolyser. The common output voltage of MF and BF can be adapted continuously in a small range.

In the bypass DC/DC operation mode, the BF power is transformed continuously by a high setting converter and added in parallel to the MF power which is coupled directly to an electrolyser. The BF is always operated at its MPP whilst the MF operating points are influenced by converter output and electrolyser. Four different power rations between directly coupled main field (MF and DC/DC-coupled bypass field (BF) and four voltage levels of the directly coupled PV-part have been examined

---

<sup>1</sup> DLR, KACST, "HYSOLAR Report phase II 1992-1995", 1996

## Technical Coupling Concepts of the Energy Converters Photovoltaic and Electrolysis

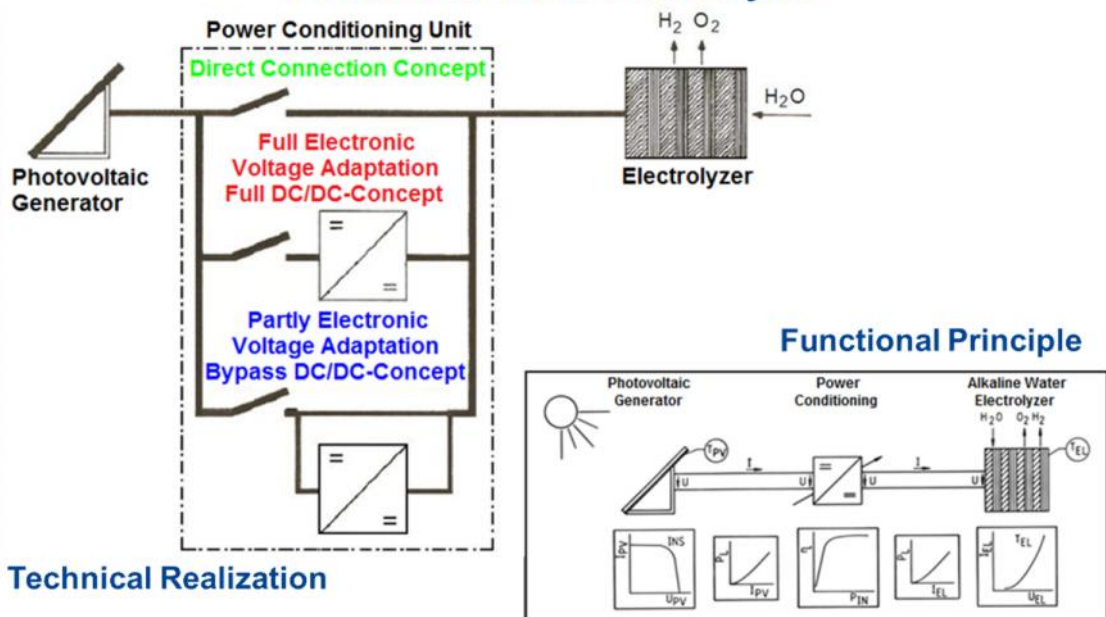

Figure 20: Three different concepts of coupling a photovoltaics field and an electrolyser system

Tests with these concepts were performed at a 10 kW photovoltaics electrolyser plant. Looking for energy conversion efficiency only and, consequently, not considering the PV-efficiency but setting the PV-generator output as the 100% reference, the Direct Connection mode has the highest system efficiency with 66.2 % compared to the Bypass DC/DC mode with 64.5 % and the Full DC/DC mode with 63 %. From this point of view the well-adapted Direct Connection concept is the best. But on the other hand the MPP-tracking concepts gain more energy from the PV-generator. The total H<sub>2</sub> output efficiency is better when using DC-DC converters due to MPP tracking of the solar field.

Today efficiency of DC-DC converters is higher than 25 years ago which causes further efficiency advantage for Electronic voltage adaptation mode. However by direct coupling costly component can be eliminated.

A fair number of projects have been set up during the past years investigating the transformation of renewable energy to hydrogen by electrolysis. Their level of coupling between the renewable source, the grid and the electrolyser varies in a wide range. Unfortunately not many details of these systems, the system components and adaptations as well as the lessons learned are publically available to help the directed development of alkaline water electrolyzers.

## ***Project impact***

### **Socio-economic impact and wider societal impact of the project**

Alkaline water electrolysis for hydrogen production is a well-established technique available commercially in a wide power range. Hydrogen production by electrolysis is increasingly studied as a way to smoothen the fluctuating power output of renewable energy sources in oversupply situations. It is a way to introduce renewable energy into the transport sector and a necessary element of the energy system transformation in several European countries (e.g. Germany or Switzerland). However, some technological issues regarding the coupling of alkaline water electrolysis and Renewable Energy Sources (RES) remain unaddressed. The RESelyser project aims at improving present electrolyzers for the specifics of direct coupling to fluctuating power operation. Also system costs have to be decreased to reach a low cost but high-efficiency energy conversion.

To address these challenges the project RESelyser - Hydrogen from RES: pressurised alkaline electrolyser with high efficiency and wide operating range - develops and investigates a new alkaline water electrolyser with improved components and a novel concept. A new separator membrane with internal electrolyte circulation (“e-bypass-separator”) and an adapted design of the cell to improve mass transfer, especially to reduce gas impurities at high pressures and low power operation, is investigated and demonstrated. Intermittent and varying load operation with RES is addressed by improved electrode stability, improved efficiency in the new cell concept. Also the system architecture is optimized for intermittent operation of the electrolyser.

It was stated in the electrolysis-development study<sup>2</sup> that “given successful cost reduction and system performance improvements, electrolyzers are expected to become more widespread in energy applications, with hundreds of installations leading eventually to hundreds of megawatts installed capacity around 2020-2025.”

This means that the topics addressed in this study might lead to a considerable electrolyser market.

With today’s automobile traffic contributing to a significant share to the emission of fossile CO<sub>2</sub> and therefore to global warming, the use of hydrogen from renewable energy sources as fuel for cars will make a major contribution to European Commission’s “2030 framework for climate and energy policy” (2014). According to this framework a reduction target for domestic 2030 greenhouse gas reduction of at least 40% compared to 1990 is set together with the other main building blocks of the 2030 policy framework for climate and energy. The German policy set up the goals to reduce greenhouse gas emissions by 40% as compared to 1990 in the year 2020, by 55 % until 2030, by 70 % until 2040 and by 80-95 % until 2050. These targets can only be met with almost complete supply of renewable energy for the transportation sector.

### **Dissemination activities and exploitation of the results**

The project ideas and results were presented at 16 conferences or meetings of the hydrogen community by 6 posters, 9 oral presentations and 2 exhibitions. 3 more oral presentations and 1 poster at conferences after the end of the project are submitted or have already been given. A summary of all dissemination activities is given in the table. More publications in peer-reviewed journals presenting the project results are in preparation.

---

<sup>2</sup> “Development of water electrolysis in the European union”, final report, E4Tech Sarl with Element Energy Ltd. For the fuel cells and joint undertaking, 2014.

A close contact and information exchange was also given during the project runtime to the project “ELYGRID” running parallel in time and also investigating alkaline water electrolyzers.

Activity	Date	Way of presentation, Title	Place	Presenter	Publically available
Hannover Fair 2012 DLR presentation at Group Exhibit Hydrogen and Fuel Cells	April 23.27 , 2012	RESelyser mentioned on Poster board	Hannover, Germany		
Copenhagen Symposium “Water electrolysis and hydrogen as part of the future Renewable Energy System” 10-11 May 2012	May 10-11, 2012	Poster “Selected hydrogen production activities at the Institute of Technical Thermodynamics of DLR”	Kopenhagen, Denmark	E. Guelzow	
19 <sup>th</sup> World Hydrogen energy conference 2012	June 3-7, 2012	Presentation: “Hydrogen from Regenerative Energy Power Sources: pressurised alkaline electrolyser with high efficiency and wide operating range The EU-Project „RESelyser““	Toronto , Canada	R. Reissner	<a href="http://www.whec2012.com/wpcontent/uploads/2012/06/WHEC_project_presentation_RESelyser-mod-Vito.pdf">http://www.whec2012.com/wpcontent/uploads/2012/06/WHEC_project_presentation_RESelyser-mod-Vito.pdf</a>
IPHE Workshop “hydrogen - a competitive energy storage medium to enable the large scale integration of renewable energies”	November 15-16, 2012	Poster “H <sub>2</sub> from RES: pressurised alk. electrolyser with high efficiency and wide operating range (RESelyser)”	Seville, Spain	D. Garcia Sanchez	
FCH-JU Program meeting Brussels	November 28-29, 2012	Presentation “Hydrogen from Regenerative Energy Power Sources: pressurized alkaline electrolyser with high efficiency and wide	Brussels , Belgium	R. Reissner	

		operating range (“RESelyser”)			
Workshop on Electrolysis and CO <sub>2</sub> Recycling	April 9-11, 2013	Poster “Hydrogen from Regenerative Energy Power Sources: pressurized alkaline electrolyser with high efficiency and wide operating range (“RESelyser”)	Roskilde, Denmark	R. Reissner	<a href="http://indico.conferences.dtu.dk/conferenceDisplay.py?confId=131">http://indico.conferences.dtu.dk/conferenceDisplay.py?confId=131</a>
Technical Forum presentation FCH-JU, Hydrogen and Fuel Cells, Hannover Fair	April 10, 2013	Presentation “RESelyser Hydrogen from RES: pressurised alkaline electrolyser with high efficiency and wide operating range”	Hannover, Germany	K.A. Friedrich	<a href="http://www.youtube.com/watch?v=K1uHMwsiBmE&amp;feature=player_embedded">http://www.youtube.com/watch?v=K1uHMwsiBmE&amp;feature=player_embedded</a>
IMC 2014	7-12 September 2014	Presentation “Microstructure Analysis of Vacuum Plasma Sprayed Electrodes for Alkaline Water Electrolysis”	Prague, Czech Republic	J.R. Bowen	<a href="http://microscopy.cz/proceedings.html">http://microscopy.cz/proceedings.html</a>
IMC 2014	7-12 September 2014	Poster “Formation of Desert Rose structures in Vacuum Plasma sprayed Electrodes for Alkaline Electrolysis”	Prague, Czech Republic	J.J. Bentzen	<a href="http://microscopy.cz/proceedings.html">http://microscopy.cz/proceedings.html</a>
Alkalische Elektrolyse Industrieworkshop	25 February 2014	Presentation “Keynote – Fortschrittliche Alkalische Elektrolyser Material- und Systemaspekte”	Cottbus, Germany	K.A. Friedrich	
Master Thesis Porto	July 2012	Master Thesis “Investigation of Vacuum Plasma Spray (VPS) Coated Anodes for Alkaline Water electrolysis”	Universidade do Porto	A.S. Felix	
Workshop ELYGRID-RESelyser	16 Dec 2014	Presentations	Brussels		
Electrohypem Workshop	9-12 Dec. 2014	Presentation	Taormina, Italy	R. Reissner	
FCH-JU-NOW Workshop	3 April 2014	Presentation “Hydrogen from Regenerative Energy Power Sources: pressurised alkaline	Brussels	R. Reissner	<a href="http://www.fch-ju.eu/news/joint-now-gmbh-%E2%80%93-fch-ju-water-electrolysis-day-">http://www.fch-ju.eu/news/joint-now-gmbh-%E2%80%93-fch-ju-water-electrolysis-day-</a>

		electrolyser with high efficiency and wide operating range The Project „RESelyser“			presentations-available
FCH-JU Project days 2013	11-13 Nov 2013	Presentation “RESelyser (278732)”	Brussels	R. Reissner	
65 <sup>th</sup> ISE Annual meeting	Sept. 2014	Poster “The E-bypass separator – A generic separator construction with endless application possibilities”	Lausanne, Switzerland	W. Doyen	<a href="http://www.ise-online.org/annmeet/folder/2014-LAUSANNE-BoA.pdf">http://www.ise-online.org/annmeet/folder/2014-LAUSANNE-BoA.pdf</a>
NMG Posterday 2014 organised by the The Dutch Membrane Society (NMG - Nederlands Membranen Genootschap) and the Belgium Membrane Group (BMG)	8 September 2014	Poster “The e-bypass separator: the solution to the inherent problem of alkaline water electrolysis under challenging working conditions”	Aachen, Germany	W. Doyen	
Bachelor Thesis Biberach	Sept. 2014	Bachelor Thesis “Untersuchung des Einflusses der Betriebsparameter auf einen alkalischen Elektrolyseur mit neuem Design“	Applied University Biberach	T. Schuster	
Hannover Fair, Hydrogen and Fuel Cells	13-17 April 2015	Handout distributed, Exhibition of cell and separator	Hannover, Germany		
Patent VITO		e-bypass membrane			
Patent Hydrogenics		High pressure electrolyser BOP			
Submitted: EST Energy, Science and Technology conference	May 2015	Presentation	Karlsruhe, Germany	R. Reissner	
Submitted: 5 <sup>th</sup>	30	Presentation	Luzern,	R.	

European PEFC and H2 Forum	June – 3 July 2015		Switzerland	Reissner	
Planned: 3rd International Workshop on Degradation issues in Fuel Cells & Electrolysers	30 September - 2 October 2015	Presentation	Greece	J.R. Bowen	
Submitted: SCANDEM2015 Annual Conference of the Nordic Microscopy Society	9-11 June 2015	Poster: Ni-hydroxide growth in vacuum plasma sprayed electrodes for alkaline electrolysis	Jyväskylä, Finland	J.J. Bentzen	
2nd International Congress on 3D Materials Science 2014	June 29 – July 2, 2014	Poster	Annecy, France	P.S. Jørgensen	<a href="http://orbit.dtu.dk/en/publications/site-specific-3d-pathway-analysis-of-functional-energy-materials%2894011b39-ba1a-4a4c-b6e5-5dc19a631787%29.html">http://orbit.dtu.dk/en/publications/site-specific-3d-pathway-analysis-of-functional-energy-materials%2894011b39-ba1a-4a4c-b6e5-5dc19a631787%29.html</a>

Many of the project results and lessons learned can be exploited at the industrial project partner Hydrogenics. For the plasma sprayed electrodes as a next step a commercial partner will be sought for a joint development and later supply of the electrodes. For the e-bypass separator licensing will be discussed with VITO and a commercial partner for production.

Any project results can also be licenced to interested parties outside the consortium. Also applications for the materials developed outside the applications considered in this project will be sought.



## Adresses



For further details see the website of the project: [www.reselyser.eu](http://www.reselyser.eu)

### **Project Coordination:**

#### **German Aerospace Center (DLR)**

Institute of Engineering Thermodynamics  
Pfaffenwaldring 38-30  
D-70569 Stuttgart  
Germany

**Contact:** Regine Reissner

Tel. +49 711 6862 394

E-mail [regine.reissner@dlr.de](mailto:regine.reissner@dlr.de)

### **Project participants:**

#### **VLAAMSE INSTELLING VOOR TECHNOLOGISCH ONDERZOEK N.V. (VITO)**

Boeretang 200

2400 MOL

Belgium

**Contact:** Yolanda Alvarez-Gallego

Tel. +32 14335612

E-mail: [yolanda.alvarezgallego@vito.be](mailto:yolanda.alvarezgallego@vito.be)

#### **HYDROGENICS EUROPE NV**

Nijverheidsstraat 48c

B-2260 Oevel (Westerlo)

Belgium

**Contact:** Jan Vaes

Tel. +32 14 462 142

E-mail: [jvaes@hydrogenics.com](mailto:jvaes@hydrogenics.com)

#### **DANMARKS TEKNISKE UNIVERSITET**

Department of Energy Conversion and Storage

Frederiksborgvej 399

4000 Roskilde

Denmark

**Contact:** Jacob R. Bowen

Tel. +45 4677 4720

E-mail [jrbo@dtu.dk](mailto:jrbo@dtu.dk)