

Wind Atlas for South Africa (WASA). Report on Measurements

Mabille, Eugène; Prinsloo, Eric; Mortensen, Niels Gylling; Hansen, Jens Carsten

Publication date:
2014

Document Version
Publisher's PDF, also known as Version of record

[Link back to DTU Orbit](#)

Citation (APA):

Mabille, E., Prinsloo, E., Mortensen, N. G., & Hansen, J. C. (2014). Wind Atlas for South Africa (WASA). Report on Measurements. Department of Energy, Republic of South Africa.

DTU Library

Technical Information Center of Denmark

General rights

Copyright and moral rights for the publications made accessible in the public portal are retained by the authors and/or other copyright owners and it is a condition of accessing publications that users recognise and abide by the legal requirements associated with these rights.

- Users may download and print one copy of any publication from the public portal for the purpose of private study or research.
- You may not further distribute the material or use it for any profit-making activity or commercial gain
- You may freely distribute the URL identifying the publication in the public portal

If you believe that this document breaches copyright please contact us providing details, and we will remove access to the work immediately and investigate your claim.



energy

Department:
Energy
REPUBLIC OF SOUTH AFRICA



Empowered lives.
Resilient nations.



sanedi

South African National Energy
Development Institute

Wind Atlas for South Africa (WASA)

Western Cape and parts of Northern and Eastern Cape

Report on Measurements

Eugène Mabilie and Eric Prinsloo
Council for Scientific and Industrial Research (CSIR)

Niels G. Mortensen, Jens Carsten Hansen
DTU Wind Energy, Technical University of Denmark

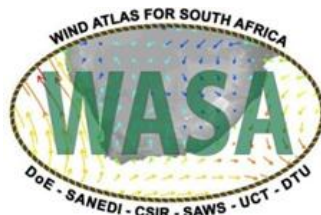

April 2014

Report on Measurements

Copyright © 2014

All rights reserved. No part of this publication may be reproduced, stored in a retrieval system, or transmitted in any form or by any means, without the express written permission of the copyright owners.

Contents

Report on Measurements	1
Contents	3
List of Figures	4
List of Tables	5
1 Introduction	6
1.1 The Importance of quality measurements	7
1.2 Measurement duration	7
2 Site selection	7
3 Measurements	9
3.1 Mast positions	10
3.2 Hardware	10
3.2.1 Masts	10
3.2.2 Earthing and Lightning protection	11
3.3 Instrumentation	12
3.3.1 Selection	12
3.3.2 MEASNET	12
3.4 Layout of wind measurement masts and sensor overview	14
3.4.1 Availability of wind measurements	16
3.4.2 Meteorological data download	17
4 Data Quality control	18
4.1 Observed wind data and quality control	18
5 Measurement best practices	20
5.1 Mast Type, Lattice or Tubular	20
5.2 Orientation	21
5.3 Guy grips	21
5.4 Certification	21
5.4.1 Security	22
5.4.2 Data Transmission	24
6 References	25
ANNEXURE A	26
Mast Specifications	26
ANNEXURE B	34
Mast Earthing Specifications	34
ANNEXURE C	37

List of Instrumentation Supplied by DTU (Risø)	37
ANNEXURE D	39
Station Logbooks	39
WM01 Station logbook	40
WM02 Station Logbook	41
WM03 Station Logbook	42
WM04 Station Logbook	43
WM05 Station Logbook	45
WM06 Station Logbook	47
WM07 Station Logbook	48
WM08 Station Logbook	49
WM09 Station Logbook	50
WM10 Station Logbook	52
ANNEXURE E	54
Data Statistics	54
ANNEXURE F	65
QA of Meteorological Data	65
Mast SA01	82
Mast SA02	82
Mast SA03	82
Mast SA04	82
Mast SA05	82
Mast SA06	82
Mast SA07	82
Mast SA08	82
Mast SA09	82
Mast SA10	82
ANNEXURE G	109
Sensor Specifications	109

List of Figures

Figure 1. Overview map showing the location of the meteorological masts referred to in the text.....	9
Figure 2. Diagram of lightning spike used for the WASA masts.....	11
Figure 3. Illustration of the 1:5 gradient cone required below the primary anemometer, outside of which objects are not allowed.....	12
Figure 4a & 4b. Anemometer installation and data logger with solar panel (excess cable coiled below data logger housing).....	13
Figure 5. Wind vane, temperature gradient sensor and temperature/relative humidity sensor (foreground)	14
Figure 6. General drawing of mast layout and sensor equipment.....	15
Figure 7. Installing the solar panel powering the data logger.....	16
Figure 8. The Website showing the online WASA data projects	18
Figure 9. A period of heavy snowfall at mast WM09 (Noupoort) on 13 to 15 July 2012 causing the anemometers to ice up.....	19
Figure 10. WM04 after the guy wires had been cut by vandals.....	23
Figure 11. Data logger enclosure belonging to WM04.....	23

List of Tables

Table 1.	Mast coordinates and elevations.....	10
Table 2.	List of sensors and types used at each measurement station.....	14
Table 3.	Status of measurements as of 1 October 2013.....	17

1 Introduction

The key to any good and accurate wind atlas is good quality data. To this end the 1st Verified Numerical Wind Atlas South Africa, for parts of the Northern and Eastern Capes as well as the Western Cape makes use of meteorological data from ten sites, distributed throughout the modelling domain, to verify the results of the meso-scale modelling. The Measurements work package (WP2) is one of six work packages that collectively make up the Wind Atlas for South Africa (WASA) project.

The measurements also provide observed wind climates at the measurement sites, which can be used by micro-siting software, like WASP, to predict the resource potential, i.e. the expected Wh production from a specified turbine or wind farm in the vicinity of the mast.

The sole objective of WP2 was to provide high quality wind measurements for a period of three years for the purpose of verifying the meso-scale modelling across the modelling domain. Criteria were established and a site selection process was undertaken with the specific aim of fulfilling the verification needs. The three year measurement campaign only started once the tenth measurement mast had been fully commissioned. The tenth mast to be commissioned was WM06 (Sutherland) and this was completed on 17 September 2010.

The outputs of WP2 are:

- i. Establish 10 high quality wind measurement stations providing three years of measurement data for calibration of the mesoscale modelling.
- ii. A database system for wind data collection and on-line Web display.
- iii. Report on measurements.

There are also some outputs not specifically listed in the project outputs. These are:

- i. Site description report
- ii. QC data from the ten sites available free of charge for download by the public.

This report documents the three year measurement campaign and includes all aspects related to the measurement of wind at the ten measurement masts. This report also provides details on where the data is located on the web (links).

1.1 The Importance of quality measurements

The adage: 'garbage in, garbage out' has relevance here especially so, because of the relationship between wind speed and wind energy. Energy produced by the wind is described as: $P=1/2 \rho U^3$, where U is the mean wind speed. From the equation it is clear that any small error or inaccuracy in the wind speed measurement translates into a threefold error or inaccuracy in the calculated energy. These errors and inaccuracies can generally be classified as uncertainties. The uncertainty in the predicted output of a wind farm depends on a number of factors, such as accuracy in topographical maps, annual variations of wind speed, heat flux etc, but also significantly due to uncertainty in the wind measurement.

It is for this reason that it is critical to keep the uncertainties in wind speed measurements as low as possible since the economic viability of a project is directly linked to predicted energy output. A standard uncertainty approaching 1% can be achieved by following international standards for calibrating and mounting of Class 1 anemometers. Routine quality control by inspection, for example with the Climate Analyst software, should be carried out on all acquired data. Comparison of the primary sensors with redundant ones should also be done.

1.2 Measurement duration

Not only should the measurements be accurate, they should also be representative of the annual wind conditions at the site. The generation of regional wind climates (using WAsP) is typically done for full years of data, the more full years the better. This ensures that the results are not affected by seasonal variations. Furthermore, missing data, due to failures of sensors or acquisition system, should be spread evenly over the year. A good number to aim for is a recovery rate exceeding 95%.

2 Site selection

Site selection is probably one of the most important activities that lead up to the installation of the wind monitoring masts. Substantial effort and money can be saved later in the project if the site selection is done with diligence. There are therefore a number of criteria that needed to be addressed during this process and some of these are listed below in no particular order.

- Topography. Mountains, escarpments, hills. Gradient of hills. Distance to mountain ranges, valleys.
- Roughness. Vegetation, forests agricultural land. Distance to towns, cities.
- Communication. GSM network, radio modem, satellite.
- Infrastructure. Access, roads, building material, concrete.
- Distance to power grid.

- Sensitive areas. Airports, nature reserves, game parks, bird migration routes, bats, SANO
- Land ownership, Private, Trust, Government, Local Authority, Tribal
- Land classification. Industrial, agricultural

In addition to the general selection criteria that needed to be taken into account there are a number of specific criteria that needed to be taken into account that will satisfy the requirements for the meso-scale modelling verification. The following criteria were developed for the WASA project:

- Spaced out fairly equally and spread all across project area
- Far enough from complex terrain (heavily mountainous), i.e. terrain slopes larger than 30° should be further than ~10km away
- At least 7km (one grid cell) away from the coast to ensure 100% land within grid cell
- Areas that are fairly uniform within a single meso-scale grid cell in terms of roughness and topography
- To ensure grid cell overlay - take two grid lengths (10km)
- Sites should cover the spectrum of different climatological regions - coastal, inland low lying, inland high lying (latter are areas that prove challenging to models).
- Ideally sites that are not too far away from each other are situated in different climatological regions.
- Sites are needed on interesting large scale terrain that have significant meso-scale forcing (e.g. near escarpment)
- In areas of good wind climate according to meso-scale maps – at least in accordance with one of the maps developed by UCT and Risø.

In order to meet some of the criteria listed above, use was made of the most recent wind resource maps available at the time for South Africa, those being UCT and Risø developed.

Once the general area, roughly thirty by thirty kilometres, for each mast had been selected, 1:50 000 maps, 1:10 000 Orthophotos and Google Earth were used to further refine the placement of the mast. Farm owners of possible sites were identified, and meetings with them were arranged. Site visits were then conducted, which involved driving around the respective areas, meeting the land owners and discussing the project with them. Basic details of each site were documented during these visits, such as: position (gps), ground type, cell phone signal strength

and prevailing wind directions (determined from the vegetation). The sites were also photographed. Once this process had been finalised and the mast position fixed, agreements between the landowners and the CSIR were formalised, allowing for the installation of the masts for a period of three years.

At the time, a Basic Impact Assessment for each mast was required, and at two sites (WM03 and WM09), municipal building regulations also had to be adhered to (temporary re-zoning of land). Getting these assessments approved caused quite a delay in the erecting of the masts.

3 Measurements

Figure shows the positions of project measurement sites in South Africa (Western Cape and parts of Northern and Eastern Cape). A total of 10 sites featuring 60 m masts are part of the project measurement programme. The site selection was aimed at best possibly fulfilling the criteria developed with the purpose of verification of the Numerical Wind Atlas. For details please see the dedicated Measurement Report and the Site Inspection Report

At 10 sites – WM1, WM2, WM3, WM4, WM5, WM6, WM7, WM8, WM9 and WM10 – the 60m masts are all instrumented with DTU developed sensors.

For the purpose of verification of the Numerical Wind Atlas, the 3 years, Oct 2010 – Sep 2013, were chosen. The data are available from the project database in the public domain through www.wasa.csir.co.za. Permission to download data may be obtained from the download site subject to registration.

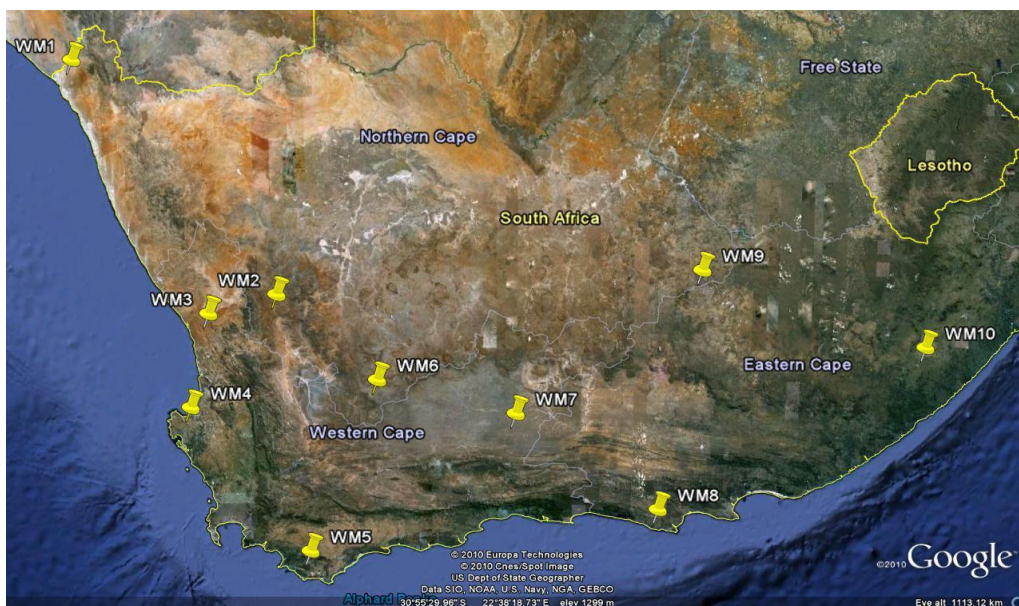

Figure 1. Overview map showing the location of the meteorological masts referred to in the text.

3.1 Mast positions

The positions of the meteorological masts were determined using a Garmin eTrex GPS receiver. Three readings were taken (corresponding approximately to the three legs of the mast) and subsequently averaged to find the position of the mast, see Table.

Table 1. Mast coordinates and elevations.

Mast ID	Longitude [°E]	Latitude [°N]	Elevation [m a.s.l.]	Easting [m]	Northing [m]	UTM zone
WM 01	16.664410	28.601882	152	662743.2	6834989.4	33
WM 02	19.360747	31.524939	824	344361.1	6511054.9	34
WM 03	18.419916	31.730507	242	255549.9	6486539.1	34
WM 04	18.109217	32.846328	22	229440.3	6362045.0	34
WM 05	19.692446	34.611915	288	380119.2	6169215.6	34
WM 06	20.691243	32.556798	1581	471013.8	6397802.7	34
WM 07	22.556670	32.966723	1047	645479.5	6351326.6	34
WM 08	24.514360	34.109965	110	270725.8	6222861.2	35
WM 09	25.028380	31.252540	1806	312257.8	6540733.5	35
WM 10	28.135950	32.090650	925	607193.9	6448951.8	35

The datum used is WGS 84; elevations are determined by the WASP flow model from SRTM3 maps with 5-m height contours.

3.2 Hardware

3.2.1 Masts

The preferred mast type for use in the WASA measurements was a narrow, triangular, guyed lattice mast. When the project started there were no suppliers who could supply a 50- 70m lattice mast of very narrow dimensions. The only supplier that had a mast close to this was Webb Masts & Towers, which could supply a mast of this height, but with a face width of 450 mm. They also had a mast with a face width of 300 mm, but this could only be supplied in a height of 45 m. Due to the minimal weight of the sensors used in a wind measurement regime, the mast engineer could, at CSIR's request, redesign this mast to suit our requirements, and raise the height to 60 m (see ANNEXURE A for the technical specifications of the mast). An anti-climbing frame surrounded by strands of razor wire was bolted to the mast at 3 m height, and utilised a lockable trapdoor through which access to the mast is acquired.

3.2.2 Earthing and Lightning protection

For lightning protection and earthing, the common practice is to run a copper conductor cable down the length of the mast and connect it to a copper earthing spike next to the base of the mast. On the WASA masts this has been done away with, and a copper earthing spike was hammered into the bottom of each excavated hole for the guy rope anchor blocks and the mast base. It is then connected to a bare copper cable which in turn connects to the hairpin guy anchor cast into the concrete (ANNEXURE B), and in the case of the mast base, to the base itself. This creates a 'Faraday cage' effect on the mast which minimises damage when lightning strikes do occur.

With the high incidences of lightning in South Africa, each mast had to be equipped with a lightning spike. According to the MEASNET¹ specifications, the lightning spike should be, on a horizontal plane, at least 50 times the diameter of the lightning spike away from the primary anemometer. This necessitated the lightning spike to be manufactured in an extended U form, to allow for the spike to be outside the specified minimum distance from the primary anemometer (see Figure 2).

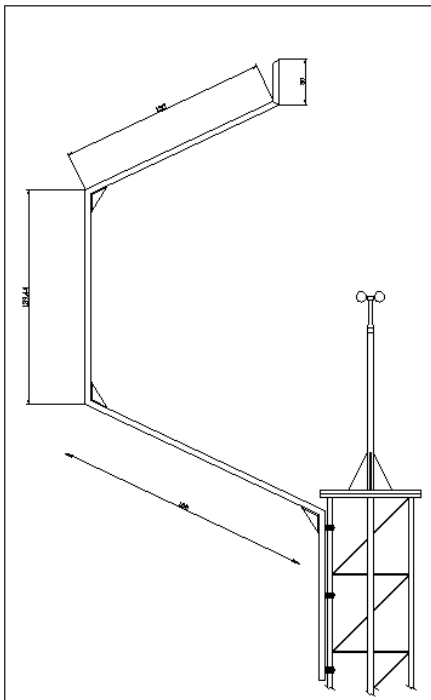

Should the primary anemometer have been mounted at the preferred 2m above the top of the mast, the lightning spike would have had to be made so long, that it would have been too tall and flexible, causing a whipping effect in strong winds that could cause it to break off and damage the sensors lower down.

For this reason the primary anemometer was mounted at 1.5m above the top of the mast, which allowed for the lightning spike to be made a little bit shorter. Where allowed, the spike was always mounted to the lee side of the dominant wind direction to minimise its effect on the primary anemometer.

Figure 2. Diagram of lightning spike used for the WASA masts

The areas Calvinia, Sutherland, Beaufort West, Humansdorp, Noupoort and Butterworth do get lots of lightning activity during the year, but fortunately none of these masts have yet had any damage caused by lightning, we suspect primarily due to the 'Faraday cage' effect of the earthing method used.

3.3 Instrumentation

3.3.1 Selection

The choice of instrumentation to be fitted to the mast is another critical aspect which should not be glossed over nor should there be an attempt to save money on the project by selecting cheap sensors. This rational can be the undoing of the project at a later stage. The instrumentation should be selected from a reputable manufacturer, particularly so for the anemometers. Each sensor must be supplied with an individual calibration certificate which conforms to an internationally recognised standard or calibration procedure. The design of the anemometer should also be taken into account as there are anemometers of various shapes and sizes. To assist the prospective wind farm developer there is literature available on the internet that discusses the suitability of the various anemometer designs for wind energy measurements

3.3.2 MEASNET

The MEASNET specifications for mounting of the primary anemometers requires them to be mounted at 2m above the mast. As explained under Lightning Protection above, for the WASA project they were mounted at 1.5m above the mast. The problem was exacerbated by the Civil Aviation Authority requirements to have a dual navigation light system mounted at the top of the mast. These have quite a bulky bracket and while every effort was made to keep the lights inside the MEASNET specified 1:5 gradient cone below the primary anemometer (Figure 3), this was not always achieved. Again where possible, the lights were mounted on the lee side of the dominant wind.

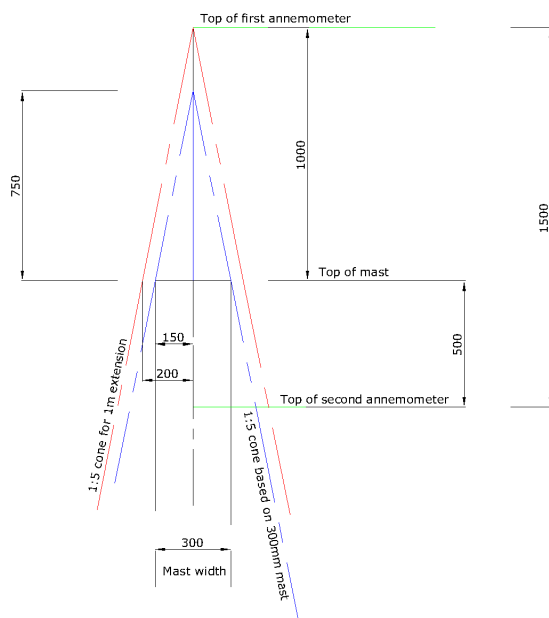

Figure 3. Illustration of the 1:5 gradient cone required below the primary anemometer, outside of which objects are not allowed

The mounting of the booms and instruments is explained in the MEASNET^[1] guidelines and IEC^[2] standards. The booms were manufactured from 50.8mm diameter aluminium pipe, with 3mm wall thickness and 2.0 m long which allowed for the anemometers to be placed at the specified 5.7 times mast width away from the mast, and perpendicular to the prevailing winds. In turn the anemometers were mounted 15 times the boom diameter above the booms.

The cable wires of each instrument were laid along the bottom of the booms and cable tied. The cabling down the mast legs were cable tied to the south facing mast legs, and at each mast section joint, given somewhat of a loop, to allow for expansion and contraction.

The solar panels for the navigation lights and the WASA data system were mounted to face just west of true North so as to catch the full spectrum of sunlight (maximum solar radiation in the western half of South Africa occurs between 13:00 and 14:00 hrs). The data logger enclosures were mounted on the southern side of the masts, with any excess cabling coiled up below the logger enclosure. The data logger itself was also earthed to the mast.



Figure 4a & 4b. Anemometer installation and data logger with solar panel (excess cable coiled below data logger housing)



Figure 5. Wind vane, temperature gradient sensor and temperature/relative humidity sensor (foreground)

3.4 Layout of wind measurement masts and sensor overview

The ten 60 m masts, WM1-WM10, instrumented with DTU developed anemometers, have been the focus of the measurement programme and of the verification. The instrumentation has been used for studies worldwide and for obtaining maximum data recovery. The specifications of the sensors are detailed in Annexure G. The instrumentation at each height level is briefly listed in Table 1 and the layout is shown in Figure 6.

Table 1. List of sensors and types used at each measurement station.

Sensor		Instrument	Heights
Cup anemometers	5	WindSensor P2546A	10m, 20m, 40m, 60m, 61.5m
Wind vane	2	Vector Instruments W200P	20m, 60m
Absolute temperature	1	Vaisala HMP45A	60m
Temperature gradient	1	Risø – DTU P2642A Pt 500	60m - 10m
Barometric pressure	1	Vaisala PTB110	6m
Relative humidity	1	Vaisala HMP45A	60m

Data loggers/ CompactFlash Module

Model: CR1000 / CFM100

Manufacturer: Campbell Scientific, Inc, United Kingdom

Height: 6 m

Calibrated by: Campbell Scientific Ltd, United Kingdom

Data Capturing

Data are sampled with 0.5 Hz. Every 10 minute statistics of the measurements average/minimum/maximum/standard deviation are calculated and recorded together with time information.

ANNEXURE C contains the complete list of instruments and accessories supplied by Risoe DTU for the WASA masts.

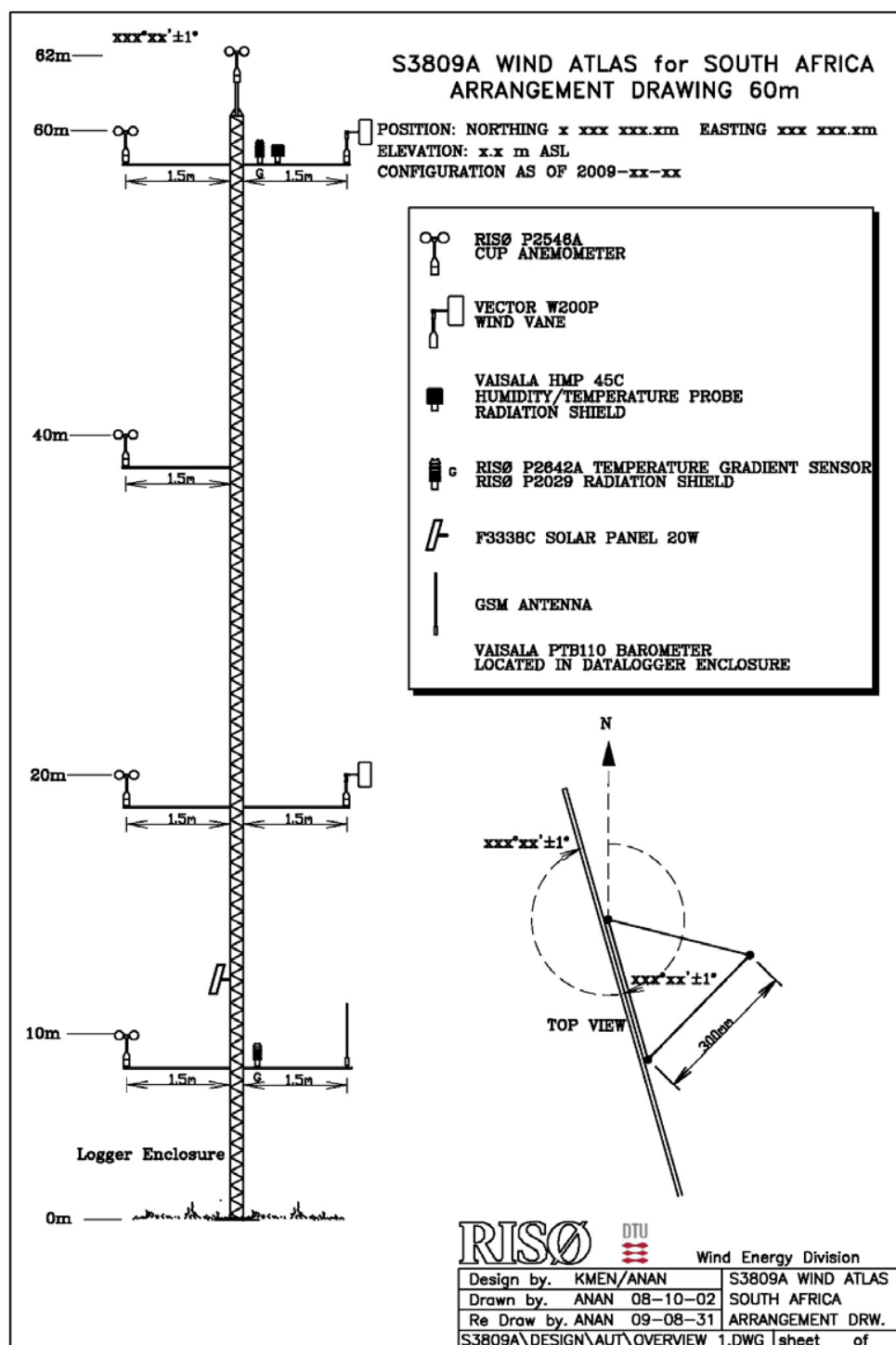

Figure 6. General drawing of mast layout and sensor equipment.

3.4.1 Availability of wind measurements

Table 2 shows the status of the meteorological measurements at the time of writing.



Figure 7. Installing the solar panel powering the data logger

Table 2. Status of measurements as of 1 October 2013.

The **Recovery** column shows the overall data recovery rate for the top-level anemometer and the **Years** column show the measurement period in years. WM09 and WM10 did not have the full three years of measurement; WM09 collapsing due to snow, and WM10 due to repeated thefts of solar panels and instrument cables.

Mast ID	Province	Data start		Days until 1Oct2013	Recovery of primary anemometer data [%]	Years [y]
		Date	Time			
WM01	N Cape	2010-06-23	20:20	1196	100.0	3
WM02	N Cape	2010-06-30	13:10	1189	93.4	3
WM03	W Cape	2010-06-24	15:40	1195	100.0	3
WM04	W Cape	2010-05-18	18:00	1117*	100.0	3
WM05	W Cape	2010-05-20	16:50	1230	98.6	3
WM06	N Cape	2010-09-17	15:10	1110	99.9	3
WM07	W Cape	2010-05-28	16:20	1222	97.0	3
WM08	E Cape	2010-08-04	13:00	1154	87.3	3
WM09	N Cape	2010-09-01	14:30	1126	99.7	2**
WM10	E Cape	2010-08-05	14:00	1153	98.8	2**

* Mast sabotaged on 7 June 2013, but 3 years of data collected

** 2-year periods for WM09 and WM10:

WM09: 2010-10 to 2013-09 minus the year 2011.

WM10: 2011-03 to 2012-02 plus 2012-10 to 2013-09.

3.4.2 Meteorological data download

Meteorological data from the 10 measurement stations can be downloaded from the web site: wasadata.csir.co.za/wasa1/WASAData . Download is free of charge, but requires registration.

The WASA data download site also contains links to the WASA Wind Atlas download site, which contains results from the micro- and meso-scale modelling, as well as further information, reports and tools.

4 Data Quality control

4.1 Observed wind data and quality control

It is advisable to have an automated screening process in place to flag any data that seems out of the ordinary. The most important data check is to have the data graphed in real time, and have these graphs visually checked on a daily basis. Any glaring and obvious problems can then be identified immediately.

The WASA measurement campaign had the Rodeo data management system, developed by DTU, installed on the WASA server, which is based at CSIR, Stellenbosch. Rodeo is a data management system where online measurement data is stored in a MySQL database, from which the WASA data is automatically displayed on a web page (<http://www.wasa.csir.co.za/>). Installation of the server and training on the Rodeo data management system was given to six CSIR personnel by two persons from DTU (Karen Enevoldsen and Steen Sørensen) on 26 Feb and 01 March 2010.



CSIR Built environment Online data Projects map | list Guest (not logged in) | Log in

Online data projects

Name	Country	Status	Latest update	Description
WM01	South Africa		2014-06-02 15:40	Alexander Bay
WM02	South Africa		2014-06-02 15:40	Calvinia
WM03	South Africa		2014-06-02 15:40	Vredendal
WM04	South Africa	mast vandalised	2013-06-06 22:40	Vredenburg
WM05	South Africa		2014-06-02 15:40	Napier
WM06	South Africa		2014-05-31 09:40	Sutherland
WM07	South Africa		2014-06-02 15:40	Prince Albert / Beaufort
WM08	South Africa		2014-06-02 15:40	Humansdorp
WM09	South Africa	back online since 2011-12-22	2014-06-02 15:40	Noupoort
WM10	South Africa	back online since 2012-07-11	2014-06-02 15:30	Butterworth

Full access
 No download
 Overview only
 No access
 [Google Earth locations](#)

Non technical requests may be directed to [Eric Prinsloo](#).

© Rise DTU National Laboratory for Sustainable Energy 2014 Comments and help requests to the [webmaster](#)

Figure 8. The Website showing the online WASA data projects

The database includes both statistical and time series. The aim was that data, which enters the CSIR WASA server automatically, initially by modem, and in 2013 through internet connection, are put in the database. The incoming data are then automatically evaluated to the extent where this is possible and then calibrated through the built-in calibration values for each sensor. Information on the quality control is stored in the Measurement Data data base, and includes the features:

- Limit checking on statistic data
- Slope checking on statistic data

- Watch for special values
- Watch for missing data

As part of this standard quality control, a message system in Rodeo was implemented for sending warnings via emails to the project manager if preset limits are exceeded or other alarm situations are discovered by the automated quality control. Also, if data fails to arrive for a specified period of time, or there is no change in value after six consecutive 10 minute logging periods, a message will be sent to the project manager.

The project manager can check these emails on a daily basis and if required, immediately interrogate those specific graphs more closely to see what prompted the warning message.

It very often happens that the 60m anemometer shows a reading less than that of the 40m anemometer. When the wind direction for that period is checked, it usually turns out that the turbulence around the navigation light assembly is responsible for the lower wind flow at the 60m anemometer, as the mast is directly in line with the boom on which the 60m anemometer is attached.

All these possible discrepancies are noted, and usually after each month, the data are downloaded and each parameter for each station is graphed, allowing a comparison of the graphs with the noted e-mail messages. If there are discrepancies, the online graphs for that particular day can be interrogated, to see what has happened. Usually, a comparison with other parameters will help to explain most discrepancies. The wind data is also run through the WASP Climate Analyst program, which produces additional graphs and tables that can be interrogated (ANNEXURE E). Any unexplained or incorrect data is deleted before the data files are uploaded to the WASA website, where the public can access the data (<http://wasadata.csir.co.za/wasa1/WASAData>).

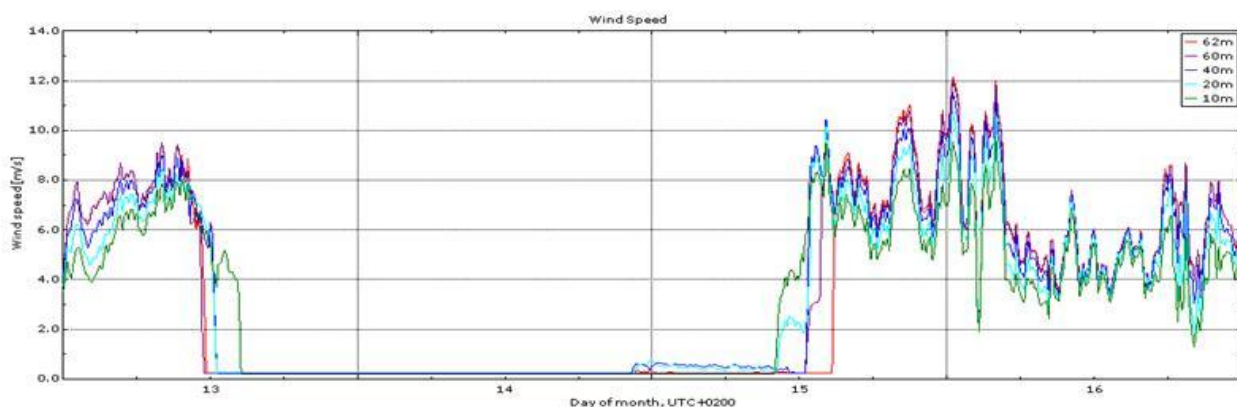

Figure 9. A period of heavy snowfall at mast WM09 (Noupoort) on 13 to 15 July 2012 causing the anemometers to ice up.

5 Measurement best practices

This chapter was drafted foremost to serve as a record of points and lessons learned during the monitoring phase (WP2) of the Wind Atlas South Africa project. It is further hoped that this will benefit and assist prospective wind energy developers in planning and executing their wind measurement campaigns.

5.1 Mast Type, Lattice or Tubular

One of the questions that anyone needing to perform wind measurements will face early on is whether to use a tubular or lattice type mast. Both have distinct advantages and disadvantages. The mast type selected for the WASA project was the 300mm wide face lattice type. It was felt that the advantage of being able to service the instrumentation without dropping the mast outweighed the initial cost savings of a tubular mast.

LATTICE TYPE	
Advantages	Disadvantages
Climbable	Cost
Easy to replace sensors	Civil works necessary. Permanent footprint
Sensors can be accurately aligned	Lengthy lead time
Security: Data logger can be placed at a greater height	Nesting birds

TUBULAR TYPE	
Advantages	Disadvantages
Cost	Un-climbable. Need to lower mast for repairs to sensors
Short lead time to erect	Need to orientate booms and sensors on the ground (reduced accuracy)
No permanent footprint	Data logger close to ground level, attraction for vandalism.

5.2 Orientation

In order to reduce the effect and influence of the mast on the wind measurements it is necessary to take the dominant wind direction or directions into account. In order to minimise any mast effects the dominant flow should be perpendicular to the mounting boom. In order to achieve this, one of the faces of a lattice mast must be orientated so that it is perpendicular to the dominant direction. This determination should be made before the civil works have begun for the installation of a lattice mast so that the anchor blocks can be orientated correctly. The dominant wind direction can be determined from data available from the South African Weather Services, the Agricultural Research Commission and CSIR. If no data are available for the area in question then environmental observations or anecdotal evidence from local inhabitants will have to suffice. All bearings and geographic orientation should finally be referenced to True North.

5.3 Guy grips

One of the accepted methods of tethering the ground end of the guy wire to the anchor block is by means of a Guy Grip. The grips are manufactured to suit a particular diameter of guy wire and are certified for this purpose by means of colour coding. However, it is possible that under certain abnormal circumstances that the Guy Grip can release its hold on the guy wire triggering a catastrophic collapse of the mast. In order to prevent this from occurring it is suggested that the loose guy wire pig tail be looped through one of the links of the anchor chain back to itself and fastened with two or three Crosby clamps. This will have the effect of a safety line so that in the event of a Guy Grip losing its hold on the guy wire, the guy wire will be retained in position until repairs to the Guy Grip can be effected.

5.4 Certification

In order to ensure that masts comply with accepted norms and standards it is necessary to have them certified by a competent engineer. For a lattice type mast the concrete anchor blocks also need to be certified. This process starts with the inspection of the excavation for each anchor block.

Certification will be required if the mast and monitoring equipment on the mast is to be insured. This will also be the case for any public liability claim in the event of injury or death resulting from the mast or section of the mast, collapsing.

Although it should be expected that the certification ensures that the mast conforms to the design specifications, it is a good idea if the owner of the mast verifies that the mast does indeed comply with the design specifications. This could be accomplished by accompanying the competent engineer on the site visits and ensuring that all aspects are checked or conducting an independent check at a later stage.

5.4.1 Security

Unfortunately security is an issue that requires some attention. The level of security needed for a particular installation does however depend on the location of the installation. Security can be broken down into two categories.

➤ Data security

Bankable wind data is the key to the success of any wind energy project and therefore it makes sense to protect the data both at the source (in the data logger) as well as after it has been downloaded. Some data loggers allow some form of user encryption to be added to the monitoring algorithm. This can be as simple as adding an offset or quadratic equation to the data.

Once the data has been downloaded from the data logger (manually or via a data transmission network) the data should be backed up and stored on a secure data base.

➤ Equipment security

Items such as solar panels, batteries, cables (copper) and SIM cards are sought after items and therefore the mast installation is vulnerable to petty criminals. It is almost impossible to prevent criminals from vandalising or stealing items from an installation, however it is possible to make it difficult for them to do so. The only problem with this approach is that you are likely to suffer more damage the more difficult it is for the criminals to remove items. In some instances the result could be the destruction of the entire mast as the thieves will not even stop short of cutting the guy wires to bring the mast down so that they can remove a battery, solar panel or SIM card (Figure 10 and Figure 11).

Solar panels and data loggers should be mounted as high up the mast as possible. The human psyche seems to have a trigger at about 10 metres above ground level which makes most humans fearful of heights above this level.



Figure 10. WM04 after the guy wires had been cut by vandals.



Figure 11. Data logger enclosure belonging to WM04.

Excess cabling should be kept to a minimum and should not be visible. Lightning protection (copper earthing) should be buried and not be visible at all.

An anti-climbing platform with a lockable trap door is a deterrent to some, but mainly children, from climbing the mast. Razor wire can also be used. The razor wire should be wrapped around the mast from the ground to below the anti-climbing platform so that the only way to reach the platform is by using a long ladder (6+ metre).

A cladding of sheetmetal around the mast at a height 3-6m above ground could also be considered. This will however also require the use of an extension ladder to gain access to the mast above the cladded section.

5.4.2 Data Transmission

Data transmission is recommended as the advantages outweigh the additional cost of hardware and data transmission.

1. Data can be evaluated with minimal delay between receipt and capture. The data can also be used for other purposes e.g. mining operations.
2. Problems at the station can be detected quickly and remedial action taken with minimal loss of data

There are various forms of data transmission (direct radio link, GSM, satellite) but the most common is GSM. In some cases a directional GSM antenna (Yagi) will have to be fitted to the modem to improve signal strength. The frequency of transmission is up to the operator but should ideally not be less than twice daily.

6 References

[1] MEASNET – Evaluation of Site-Specific Wind Conditions. Version 1, 2009

[2] IEC (2005) International standard IEC61400-12-1 Ed.1: Part 12-1: Power performance measurements of electricity producing wind turbines

ANNEXURE A

Mast Specifications

H. LAWRENCE CONSULTING cc
Registered Firm – South African Association of Consulting Engineers

DESIGN MANUAL

for

CSIR

of

60m WEBB TYPE 300N GUYED MASTS WITH 2.0m POLE EXTENSION

DESIGN ANALYSIS

CONTENTS: -

Reference Number	Sheet Number	Description
EXCEL – 09-102-11	11	GENERAL ARRANGEMENT OF MAST
EXCEL – 09-102-12	12	Vz LOADINGS
EXCEL – 09-102-13	13	66m MAST SECTION PROPERTIES
EXCEL – 09-102-14	14	EQUIPMENT LOADING & RESULTS
EXCEL – 09-102-15	15	GUY FOUNDATION DESIGNS
EXCEL – 09-102-16	16	LeBlanc GUY FOUNDATION DESIGNS
WORD – 09-102-17	17	FRONT PAGE

Partners: H.Lawrence, Pr.Eng., F.I.STRUC.E., M.A.I.C.E., M.S.A.C.E.
Pr. Eng. 702699 – 26 January 1970

H LAWRENCE CONSULTING cc

Registered Firm - South African Association of Consulting Engineers

Tel: +27 (011) 883 1544

e-mail: <hlp@iafrica.com>

Fax: +27 (011) 884 5584

Made by: H L

Date: 16 September 2009

Job No: 09/102

Sheet No: 11

Client: WEBB - CSIR

Subject: CHECK DESIGN OF 60m TYPE 300N WEBB GUYED MAST + 2m EXTENSION

Specification Site altitude 1000m Terrain category 1B
 Mean return 50 years Wind speed 40

Height Nodes Solar Panel @ 15m Wind Equipment Sensors @ 2/12m, 2/21m, 42m, 2/60m & 62m
 m No. 6mm dia. Guy rope tensioning @ 1.6kN

Height	Radius	Length	Vertical force	In 3 kN
62	22			
60	21			
57	20			
54	19			
51	18			
48	17			
45	16			
42	15			
39	14			
36	13			
33	12			
30	11			
27	10			
24	9			
21	8			
18	7			
15	6			
12	5			
9	4			
6	3			
3	2			
0	1			
		9	0.6058	1.8174
		18	1.0132	3.0395
		27	1.2404	3.7211
		36	0.9600	2.8800
		48	1.1314	3.3941
		60	1.2494	3.7482
			Total	18.6004 kN

Solar Panel Details Mass say 5kgs = 0.05kN
 Wind say 16kgs = 0.16kN

Wind Equipment Sensor Details (Mounting arm 34 o/d)

Mass with mounting arm say 3kgs = 0.03kN
 Wind with mounting arm say 8kgs = 0.08kN

Guy Rope Mass - 0.214kg/m

Height	Mass	In 3 kgs	In 3 kN	Wind On 2 kN
9	1.926	5.778	0.057	0.3412
18	3.852	11.556	0.113	0.4080
27	5.778	17.334	0.170	0.4999
36	7.704	23.112	0.227	0.8612
48	10.272	30.816	0.302	0.9743
60	12.840	38.520	0.378	1.1028
	Total	127.116	1.246	4.1873

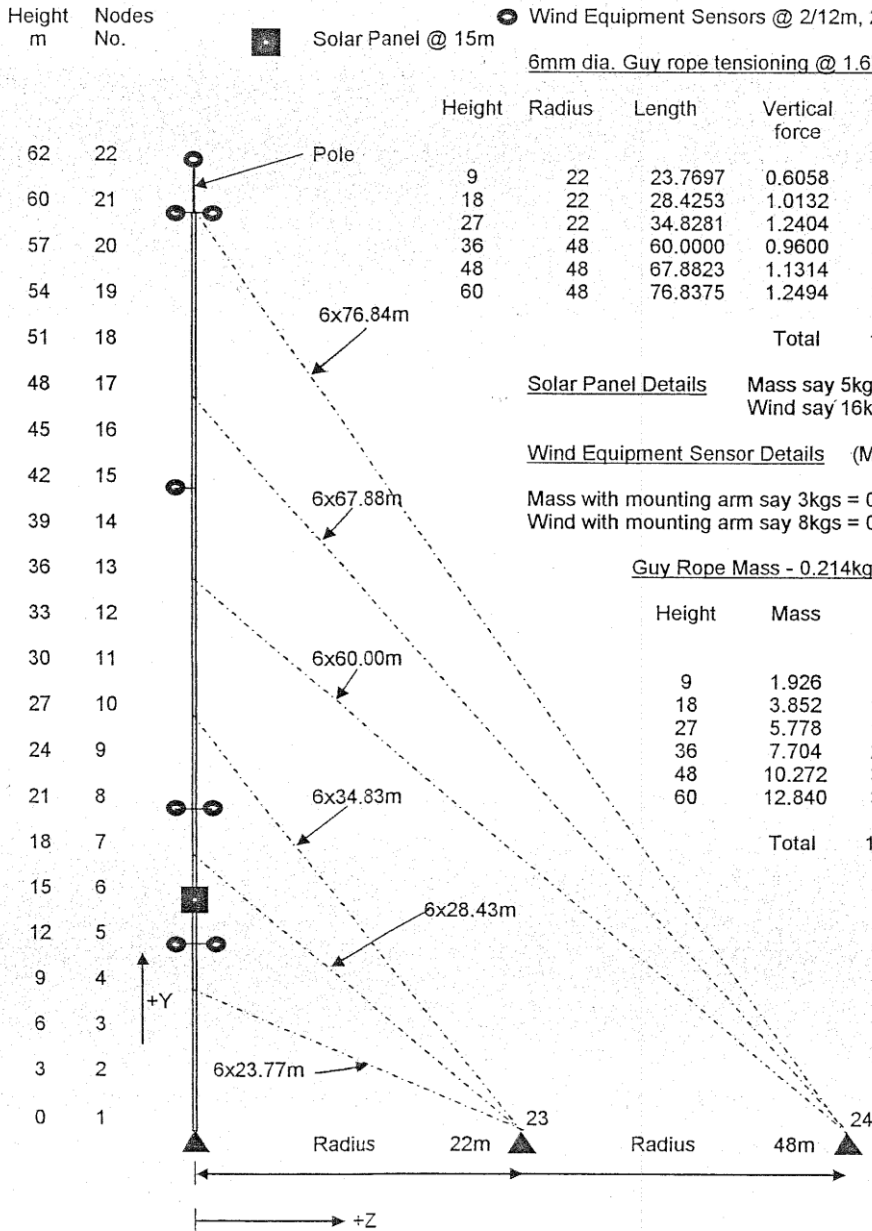

From: VZ LOADS Tc1-Tc4
 Comp ref: EXCEL - 09-102-11 - 60m + 2m G. A. OF MAST FOR WEBB - CSIR PROJECT

H LAWRENCE CONSULTING cc

Registered Firm - South African Association of Consulting Engineers

Tel: +27 (011) 883 1544

e-mail: <hlp@iafrica.com>

Fax: +27 (011) 884 5584

Made by: H L

Date: 16th September 2009

Job No: 09/102

Sheet No: 12

Client: WEBB - CSIR

Subject: CHECK DESIGN OF 60m TYPE 300N WEBB GUYED MAST + 2m EXTENSION

BASIS OF DESIGN is SABS 0160-1989 & SABS 0162-3:1984
 SITE ALTITUDE is (Max 2000m) 1000 metres kp = 0.53
 MEAN RETURN is 50 years Mr = 1
 TERRAIN CATEGORY is 1 Class B
 WIND SPEED is 40 m/s 144 km/hr
 ARTIFICIAL BASE HEIGHT is 0 metres
 Zg = 250 Zo = 0 Root = 0.073

Area Climbing Ladder 0.0 m²/m Area of feeder cable tube (25 o/d) 0.030 m²/m

Mean Leg Centres m	Leg Face mm	Bracing Diam mm	Area Gross per / 3m	Area legs per / 3m	Lacings / Bracings per / 3m	Total Area per / 3m	Sr	Cf
0.300	34	10	1.0020	0.204	0.0806	0.2846	0.2841	1.332

HEIGHT	Vz	Qz	Wind on face	Wind on CL & CT	Total wind kN/m	Area C T	0.030	m ² /m
3	39.3894	0.8223	0.1039	0.0329	0.1368			
6	41.4338	0.9099	0.1150	0.0364	0.1513			
9	42.6785	0.9654	0.1220	0.0386	0.1606			
12	43.5842	1.0068	0.1272	0.0402	0.1675			
15	44.3000	1.0401	0.1314	0.0416	0.1730			
18	44.8936	1.0682	0.1350	0.0427	0.1777			
21	45.4016	1.0925	0.1381	0.0437	0.1817			
24	45.8463	1.1140	0.1408	0.0445	0.1853			
27	46.2422	1.1333	0.1432	0.0453	0.1885			
30	46.5993	1.1509	0.1454	0.0460	0.1914			
33	46.9246	1.1670	0.1475	0.0466	0.1941			
36	47.2236	1.1819	0.1494	0.0472	0.1966			
39	47.5004	1.1958	0.1511	0.0478	0.1989			
42	47.7580	1.2088	0.1528	0.0483	0.2011			
45	47.9992	1.2211	0.1543	0.0488	0.2031			
48	48.2258	1.2326	0.1558	0.0493	0.2050			
51	48.4398	1.2436	0.1571	0.0497	0.2068			
54	48.6423	1.2540	0.1585	0.0501	0.2086			
57	48.8347	1.2640	0.1597	0.0505	0.2102			
60	49.0179	1.2735	0.1609	0.0509	0.2118			

3.7499 by 3 = 11.2496 kN

Height	Radius	Length	Wind	Wind on guys - Qz taken as 1.1509kN/m ²
9	22	23.7697	0.3411	
18	22	28.4253	0.4080	
27	22	34.8281	0.4999	
36	48	60.0000	0.8611	
48	48	67.8823	0.9743	
60	48	76.8375	1.1028	
Total			4.1871	

From: VZ LOADS Tc1-Tc4

Comp ref: EXCEL - 01-102-12 Vz LOADING - WEBB - CSIR

Tel: +27 (011) 883 1544 e-mail: <hlp@iafrica.com> Fax: +27 (011) 884 5584
 Made by: H L Date: 16th September 2009 Job No: 09/102 Sheet No: 13

Client: WEBB - CSIR PROJECT
 Subject: CHECK DESIGN OF 60m TYPE 300N WEBB GUYED MAST + 2m EXTENSION

LEG TUBE o/d in cm	3.4 cm (#)	GROSS AREA - PLAN	2.47400449 cm ²
LEG TUBE wall in cm (#)	0.25 cm (#)	GROSS AREA - PLAN	0.0002474 m ²
LEG TUBE i/d in cm	2.9 cm	MASS PER METRE	1.93961952 kg
Centre to centre length (#)	0.500 m (#)	MOMENT OF INERTIA xx	3.08786685 cm ⁴
Effective length in metres	0.500 m	MOMENT OF INERTIA yy	3.0879E-08 m ⁴
Input value of Po - 153 for grade 43;		SECTION MODULUS x - x	1.81639227 cm ³
184 for 300W; 215 for grade 50;	184 (#)	SECTION MODULUS y - y	1.81639227 cm ³
Diam of holes for splices in cm	0 cm (#)	RADIUS OF GYRATION	1.11719515 cm
CALCULATION RESULTS BELOW		I/r RATIO	44.7549384
fy = 299.92	fcr = 1015.0446	ALLOWABLE Pc	162.955918 MPa
n = 0.0600901	X = 687.9794	ALLOWABLE FORCE "T"	45.5216826 kN
Pc = 162.95592	Xx = 1309.96	ALLOWABLE FORCE "C" (Fc)	40.3153672 kN
P30= 171.11977	Final Pc = 162.95592 Mpa	MAXIMUM "L" (180)	2.01095127 m
		MAXIMUM "L" (250)	2.79298787 m

BRACE ROD o/d (Diagonal)	1.0 cm (#)	GROSS AREA - PLAN	0.78539825 cm ²
Centre to centre length (#)	0.558 m (#)	GROSS AREA - PLAN	7.854E-05 m ²
Effective length in metres	0.558 m	MASS PER METRE	0.61575223 kg
Input value of Po - 153 for grade 43;		MOMENT OF INERTIA xx	0.04908739 cm ⁴
184 for 300W; 215 for grade 50;	153 (#)	MOMENT OF INERTIA yy	4.9087E-10 m ⁴
Diam of holes for splices in cm	0 cm (#)	SECTION MODULUS x - x	0.09817478 cm ³
CALCULATION RESULTS BELOW		SECTION MODULUS y - y	0.09817478 cm ³
fy = 249.39	fcr = 40.811136	RADIUS OF GYRATION	0.25 cm
n = 1.4945472	X = 175.59765	I/r RATIO	223.2
Pc = 18.749088	Xx = 1284.695	ALLOWABLE Pc	18.7490882 MPa
P30= 142.39346	Final Pc = 18.749088 Mpa	ALLOWABLE FORCE "T"	12.0165932 kN
		ALLOWABLE FORCE "C" (Fc)	1.47255011 kN
		MAXIMUM "L" (180)	0.45 m
		MAXIMUM "L" (250)	0.625 m

SECTION PROPERTIES OF TRIANGULAR SECTION

LEG FACE CENTRES "F"	30 cm	GROSS AREA - PLAN	7.42201346 cm ²
LEG FACE CENTRES "F"	0.3 m	GROSS AREA - PLAN	0.0007422 m ²
LEG DEPTH CENTRES "D"	25.981 cm (#)	MASS OF TOTAL SECTION	8.3720 kg/m
LEG DEPTH CENTRES "D"	0.2598076 m	MOMENT OF INERTIA xx	1122.56562 cm ⁴
Centre to centre length (#)	9.0 m (#)	MOMENT OF INERTIA yy	1.1226E-05 m ⁴
Effective length in metres	9.0 m	SECTION MODULUS x - x	59.0186979 cm ³
Input value of Po - 153 for grade 43;		SECTION MODULUS y - y	67.2194982 cm ³
184 for 300W; 215 for grade 50;	184 (#)	RADIUS OF GYRATION	12.2982976 cm
Diam of holes for splices in cm	0 cm (#)	I/r RATIO	73.1808601
CALCULATION RESULTS BELOW		ALLOWABLE Pc	128.12879 MPa
fy = 299.92	fcr = 379.64007	ALLOWABLE FORCE "T"	136.565048 kN
n = 0.1606631	X = 370.27712	ALLOWABLE FORCE "C" (Fc)	95.0973605 kN
Pc = 128.12879	Xx = 1309.96	MAXIMUM "L" (180)	22.1369358 m
P30= 171.11977	Final Pc = 128.12879 Mpa	MAXIMUM "L" (250)	30.7457441 m

LEG FACE CENTRES "F"	30 cm	GROSS AREA - PLAN	7.42201346 cm ²
LEG FACE CENTRES "F"	0.3 m	GROSS AREA - PLAN	0.0007422 m ²
LEG DEPTH CENTRES "D"	25.981 cm (#)	MASS OF TOTAL SECTION	8.3720 kg/m
LEG DEPTH CENTRES "D"	0.2598076 m	MOMENT OF INERTIA xx	1122.56562 cm ⁴
Centre to centre length (#)	12.0 m (#)	MOMENT OF INERTIA yy	1.1226E-05 m ⁴
Effective length in metres	12.0 m	SECTION MODULUS x - x	59.0186979 cm ³
Input value of Po - 153 for grade 43;		SECTION MODULUS y - y	67.2194982 cm ³
184 for 300W; 215 for grade 50;	184 (#)	RADIUS OF GYRATION	12.2982976 cm
Diam of holes for splices in cm	0 cm (#)	I/r RATIO	97.5744802
CALCULATION RESULTS BELOW		ALLOWABLE Pc	89.0493729 MPa
fy = 299.92	fcr = 213.54754	ALLOWABLE FORCE "T"	136.565048 kN
n = 0.2856234	X = 287.23085	ALLOWABLE FORCE "C" (Fc)	66.0925645 kN
Pc = 89.049373	Xx = 1309.96	MAXIMUM "L" (180)	22.1369358 m
P30= 171.11977	Final Pc = 89.049373 Mpa	MAXIMUM "L" (250)	30.7457441 m

Comp : EXCEL - 09-102-13 SECTION PROPERTIES - 300N TYPE MAST FOR WEBB - CSIR PROJECT

H. LAWRENCE CONSULTING cc

Registered Firm – South African Association of Consulting Engineers

Office +27 (011) 883 1544

e-mail: <hlp@iafrica.com>

Fax +27 (011) 884 5584

Made by H L

Date 16th September 2009

Job No. 09/102

Sheet No. 14

Client: WEBB - CSIR PROJECT

Subject: CHECK DESIGN OF 60m TYPE 300N WEBB GUYED MAST + 2m EXTENSION

ACTUAL EQUIPMENT LOADING ALLOWED FOR - LOAD CASE 3

Mounting height	Antenna type	Quant	Wind each	Total wind	Mass each	Total mass	Node	X - load per node kN	Y - load per node kN
12	Equipment Sensor	2	8	16	3	6	5	0.157	0.059
21	Equipment Sensor	2	8	16	3	6	8	0.157	0.059
42	Equipment Sensor	1	8	8	3	3	15	0.078	0.029
60	Equipment Sensor	2	8	16	3	6	21	0.157	0.059
62	Equipment Sensor	1	8	8	3	3	22	0.078	0.029
15	Solar Panel	1	16	16	5	5	6	0.157 0.784	0.049 0.284

SUMMARY OF APPLIED LOADS - LOAD CASE 2

Height	Description	Y Mass kg	Y Preten. kN	Y Vertical Total kN	X Horizontal wind	Node
9	Guy mass, Pretension & wind	5.778	1.817	1.8740	0.3412	4
18	Guy mass, Pretension & wind	11.556	3.040	3.1528	0.4080	7
27	Guy mass, Pretension & wind	17.334	3.721	3.8910	0.4999	10
36	Guy mass, Pretension & wind	23.112	2.880	3.1066	0.8612	13
48	Guy mass, Pretension & wind	30.816	3.394	3.6961	0.9713	17
60	Guy mass, Pretension & wind	38.520	3.748	4.1256	1.1028	21
Totals				19.8462	4.1844	

SUMMARY OF MAST SELF WEIGHT - LOAD CASE 4

Actual Mass of mast / m	Legs	5.1886	Lacings In 60m	3.1837 4.926	Total kN	8.372 0.0821 = 0.2463	kg/m kN/m kN/3m
Wind on mast				11.2496	kN		

At level 60m a deflection is calculated as 175.2 mm Equivalent of 1 : 343
 At level 62m a deflection is calculated as 183.5 mm Equivalent of 1 : 338

Maximum recorded vertical load in mast at 36m is 16.51kN < 66.093kN allowable
 Maximum recorded vertical load in mast at base is 39.38kN < 95.097kN allowable

Maximum recorded loads in guy ropes	Nodes	Size	Force	Allowable	Status
	4 - 23	6 mm dia	2.28	8.07 kN	O.K.
	7 - 23	6 mm dia	3.04	8.07 kN	O.K.
	10 - 23	6 mm dia	3.27	8.07 kN	O.K.
	13 - 24	6 mm dia	4.00	8.07 kN	O.K.
	17 - 24	6 mm dia	5.11	8.07 kN	O.K.
	21 - 24	6 mm dia	4.24	8.07 kN	O.K.

Conclusion:- This guyed mast is very adequate for its design requirements and shows good FOS's

Comp : EXCEL - 09-102-14 EQUIPMENT LOADING & RESULTS - WEBB - CSIR PROJECT

H LAWRENCE CONSULTING cc - Tel: +27 (0)11 883 1544

WEBB / CSIR - 60m + 2m TYPE 300N GUYED MAST FOUNDATIONS FOR STANDARD SITES

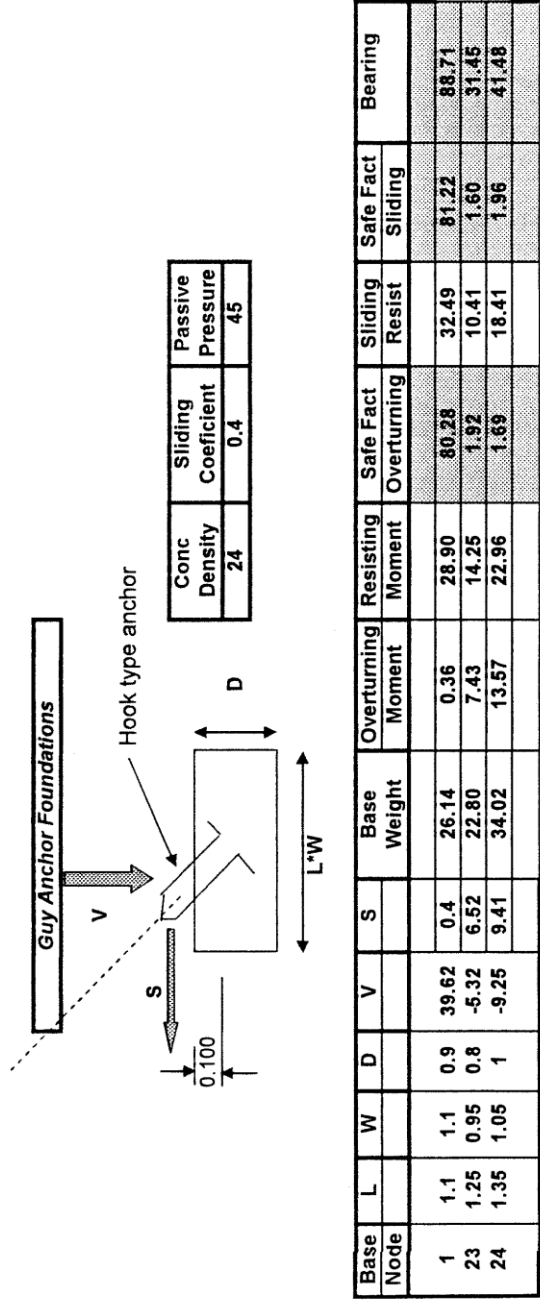

Base Node	L	W	D	V	S	Base Weight	Overturning Moment	Resisting Moment	Safe Fact Overturning	Sliding Resist	Safe Fact Sliding	Bearing
1	1.1	1.1	0.9	39.62	0.4	26.14	0.36	28.90	80.28	32.49	81.22	88.71
23	1.25	0.95	0.8	-5.32	6.52	22.80	7.43	14.25	1.92	10.41	1.60	31.45
24	1.35	1.05	1	-9.25	9.41	34.02	13.57	22.96	1.59	18.41	1.96	41.48

Total volume of concrete = 8.1915 m^3

Comp ref: EXCEL - 09-102-15 GUY FDTN DESIGN

21 September 2009



300N GUYED MAST by HEIGHT 60 + 2m

SABS 0160-1989 & SABS 0162-3:1984
 Site Altitude 1000m
 Mean Return 50 Years
 Terrain Category 1 Class B
 Wind Speed 40 m/s
 ABH 0.00

Client: - CSIR

a)	VOLUME OF CONCRETE REQUIRED		8.1915	m ³
b)	ANGLE OF REPOSE OF SOIL		30	degrees
c)	FOUNDATION BOLTS ARE M20 dia. @ 355 CROSS CENTRES & PROJECT 40mm			
d)	MASS OF MAST	503	kg	
e)	MASS OF SUNDRIES	60	kg	Total mass 691 kg
f)	MASS OF GUYS	128	kg	

DESCRIPTON	Unit	A	B	C	D
VERTICAL LOAD	kN	39.62	5.32	9.25	
HORIZONTAL LOAD	kN	0.4	6.52	9.41	
BENDING MOMENT	kNm	0	0	0	
BEARING PRESSURE	kPa	88.71	31.45	41.48	
FOUNDATION LENGTH	m	1.1	1.25	1.35	
FOUNDATION L1	m		0.42	0.45	
FOUNDATION L2	m		0.83	0.90	
FOUNDATION WIDTH	m	1.1	0.95	1.05	
FOUNDATION DEPTH	m	0.9	0.8	1.0	
DEPTH BELOW G.L.	m	0.8	0.7	0.9	

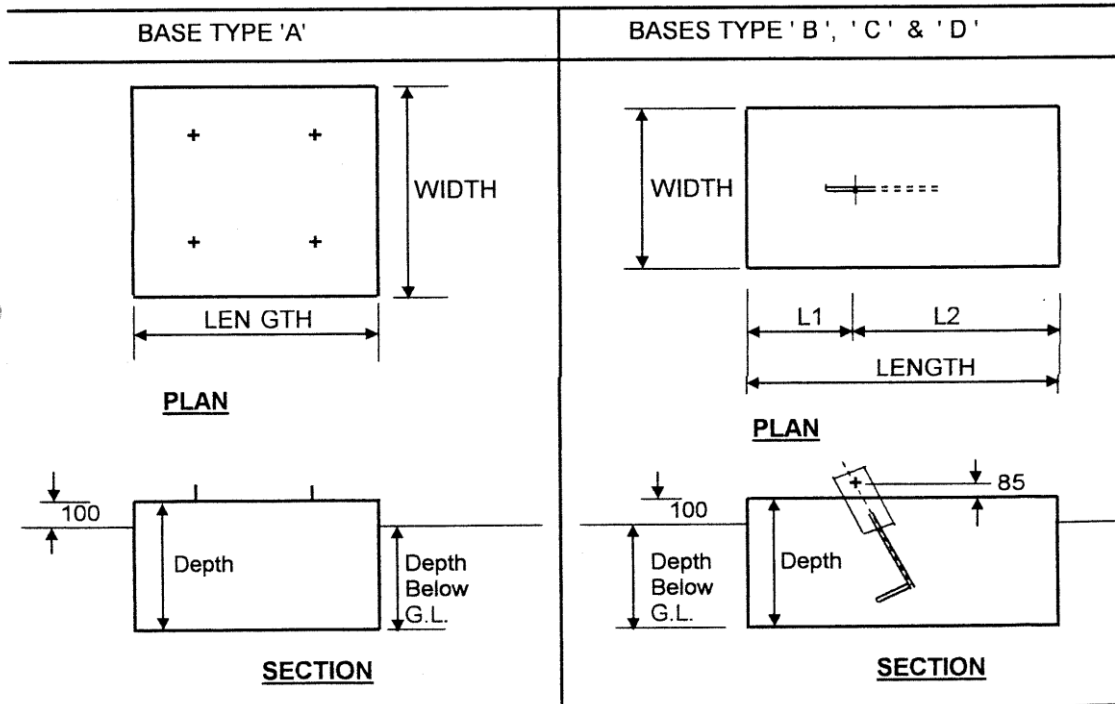

H LAWRENCE CONSULTING cc

Registered Firm - South African Association of Consulting Engineers

Tel: +27 (011) 883 1544

e-mail: hlp@iafrica.com

Fax: +27 (011) 884 5584

Made by: H L

Date: 16 September 2009

Job No. 09/102

Sheet No. 16

Comp ref: EXCEL - 09-102-16 - **300N GUYED FOUNDATION DESIGNS**

ANNEXURE B

Mast Earthing Specifications

Updated 13/04/10

EARTHING OF CSIR MASTS**EACH GUY STAKE**

1,2 X 16 copper rod inserted into bottom of excavated hole and connected to hairpin guy anchor with 70mm² bare copper, using copper clamp at earth rod, and 70 x 10 lug + M10 x 40 brass bolt and nut at Hairpin

MAST BASE

24m 25 x 3 flat copper buried in TRENCHES 500mm deep of 6m x 6m x 6m x 6m at 90°
Copper strap clamped to earth rod which then connected to H-plate on caged bolts, by means of 70 x 10 lug + M10 x 40 brass bolt and nut.

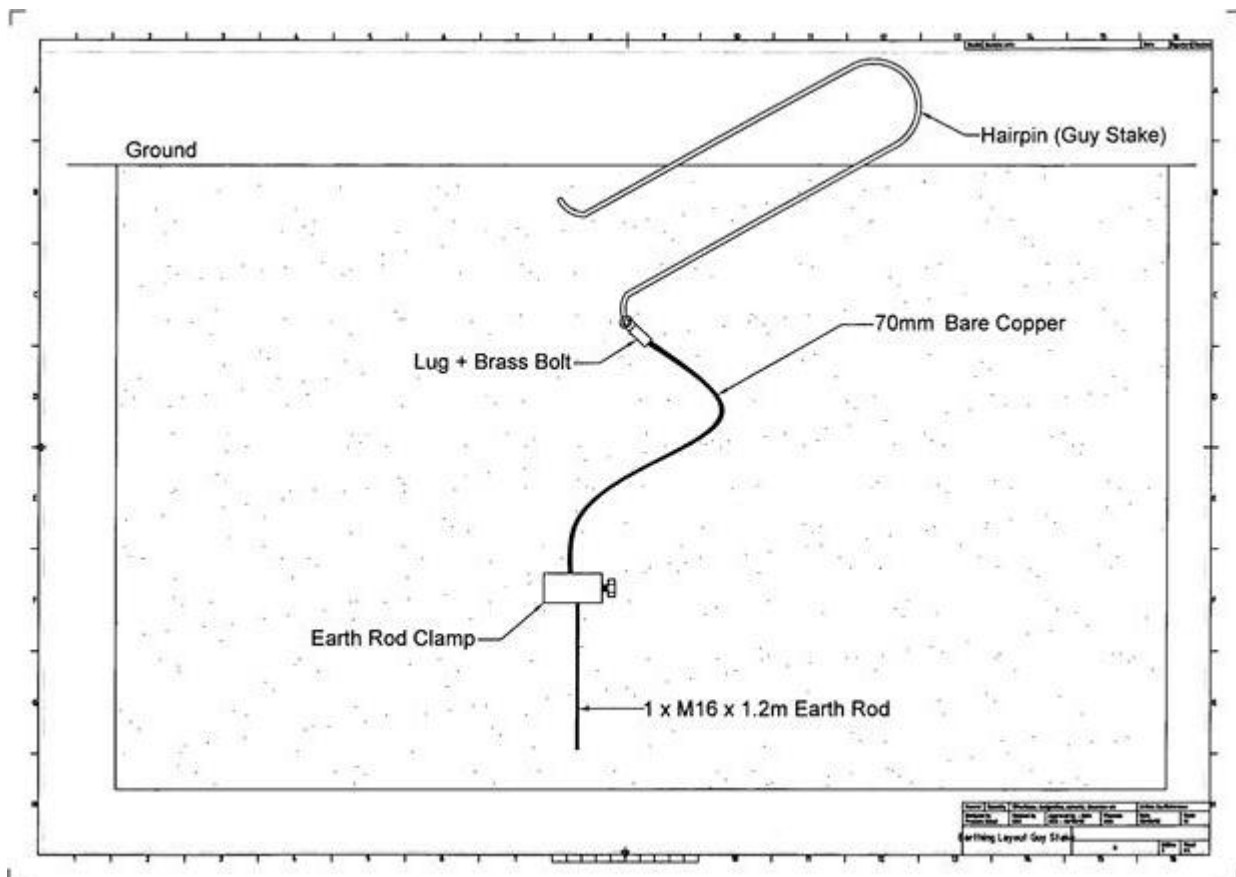

Dear Eric

You asked me to advise you in writing as to the reason why we consider down-conductors to be superfluous on masts and towers.

By way of background, The Polyphaser Corporation, who are arguably one of the foremost authorities in the world on lightning protection, have for the past 20 years advised their customer base that a down-conductor serves no useful purpose and is a waste of money. Over the years most of the major telecoms companies such as MTN have no longer included down-conductors in their specs.

Normally a down conductor is of 70mm sq. cross sectional area which is infinitesimal compared to the cross-sectional area of structure to which it is attached.

In engineering terms the electrical inductance provided by the down-conductor is minimal compared to that of the structure.

As an aside, it is no longer common practice in the South African crime environment to have any copper exposed as it will be the first item to be stolen.

Best Regards,

Murray Webb

Webb LeBLANC Communications

Tel: [+27 11 444 2299](tel:+27114442299)

Cell: [+27 83 457 7543](tel:+27834577543)

ANNEXURE C

List of Instrumentation Supplied by DTU (Risø)

List of instrumentation supplied by RISOE DTU

Wind Energy Division Risø DTU
 Technical University of Denmark
 Risø National Laboratory for Sustainable Energy
 Frederiksborgvej 399, P.O. Box 49
 DK-4000 Roskilde
 Direct +45 4677 4677

Consignee:

South African National Energy Research Institute (SANERI)
 A subsidiary of CEF (PTY) LTD
 First Floor, CEF House
 Block C, Upper Grayston Office Park
 152 Ann Crescent, Strathavon 2031
 Sandton

Senior Manager: Clean Energy Solutions
 Dr. Thembakazi N. Mali

Tel. +27 10 201 4782
 Cell. +27 82 326 9501
 Fax. +27 10 201 4932

Delivery address:

CSIR, Built Environment
 Jan Cilliers Street
 Stellenbosch, South Africa
 7600

Contact person:

Eric Prinsloo
 Tel +27 21 888 2439

PACKING LIST	Quantity
WIND STATION	
1 Colli : 95 Kg; 118 X 78 X 62cm NON WOOD	
P3441A Datalogger enclosure	1.00
Campbell CR1000 Datalogger	
Siemens TC35i GSM modem	
Vaisala Barometer model PTB110	
Campbell CFM100 memory module	
Flash card	
Battery cable	
F3338A Solar panel w. bracket	1.00
GSM antenna	1.00
Antenna cable	1.00
Bracket f. GSM antenna	1.00
P3505A Junction box	1.00
F2920C Vaisala HMP45	1.00
Radiation shield f. HMP45	1.00
P2642 Temperature gradient sensor	2.00
P2029 Radiation shield	2.00
Support pole f. Tgrad sensor	2.00
F2919A Vector W200P Wind vane	2.00
Support pole f. Vector windvane	2.00
P2546A Cup anemometer	5.00
Support pole f. Cup anemometer	5.00
Battery 12V	1.00
P2546A Cup anemometer cables (2x5m 1x14m)	3.00
P2546A Cup anemometer cables (1x32m 1x50m)	2.00
F2919A Vector W200P wind vane extension cable	1.00
P3104 Junction box cable	1.00
Tool (screwdriver, serial cable and key f. Enclosure))	1.00
Top tube Adaptor	1.00
Documentation	1.00

ANNEXURE D

Station Logbooks

WM01 Station logbook

Name of station: WM01 Alexander Bay	Location: -28° 36' 6.77" S, 16° 39' 51.88" E, 152 m A.S.L
Contact person: Eric Prinsloo	System serial / reference #: 460

Date	Time	Event	Observations	Actions	Comments	ID
23/06/2010	15:30	Instrument installation			Completed instrument installation	EP
06/04/2011	15:00 – 17:00	Site Description visit	Station seems ok, guy rope foundations and mast foundation not overblown by sand	Painted mast foundation, and lower 40cm section of mast with creosote paint as per instructions from mast engineer. Cleared one nest in mast, and cleaned solar panels. Clamped 20mWD sensor in line with boom for less than 3min (direction check)	Attached CSIR asset label to mast. Modem still running directly from battery, thus logger still using original SAWA_0_4.CR1 program	EP, NGM, SS, SM
07/02/2012	13:00 – 17:00	EM Visit to check mast while in the area, do modem modification and upload SAWA_0_6.CR1 program to logger	Station seems ok. There was one nest on the anti-climbing device, and one right at the top of the mast	Did modem change and downloaded data. Then uploaded SAWA_0_6.CR1 to logger using cable connection to notebook. GPRS communications to all the westerly stations were off.	The nest on the anti-climbing device was removed, but the one at the top could not be removed as EM does not have mast climbing certificate. This nest could have an influence on the air flow around the top of the mast, but should not affect the primary anemometer	EM
25/02/2013	8:00 – 14:00	Site visit by EP, JK & SM to check general condition of mast & instruments, and do mast verticality checks with Leica Total Station	Nest at top of mast and on platform Some rust on shackles and turn buckles. All instruments still mounted vertically. Solar panels full of bird droppings. Nav light still working. Nav light battery box extremely corroded	Nests were removed. Rust treated. Rust on nav light box was scraped & sanded off, and resprayed.	General condition of instruments and mast looks good. Nav light box will have to be replaced soon.	EP

WM02 Station Logbook

Name of station: WM02 Calvinia/Niewoudtville	Location: 31°31'29.7798"S, 19°21'38.6886"E, 824 m A.S.L
Contact person: Eric Prinsloo	System serial / reference #: 488

Date	Time	Event	Observations	Actions	Comments	ID
30/06/2010	16:00	Instrument installation			Completed instrument installation	EP, EM, PT, SM
05/04/2011	12:00 – 15:00	Site Description visit	Couple of bird nests in mast; one on anti-climbing platform, small nest in cable loops, and two nests just below 20m booms. Otherwise mast looks ok.	Cleared nests away and also cleaned solar panels from bird droppings. 20mWD clamped in line with booms for less than 3 min.	Modem still powered directly from battery, thus logger still using original SAWA_0_4.CR1 program	EP, NM, SS, SM
26/01/2012	14:00 – 17:00	Mast inspection while in the area. Modem not connecting. To do modem modification and upload SAWA_0_6.CR1 program	Mast seems ok, guy ropes as well. There were two nests, one on the ant-climbing device and the other right at the 40m boom.	The modem modification was done, and data downloaded from the 19 th of Dec 2011, before the new SAWA_0_6.CR1 program was uploaded to the logger using the notebook.	The nest on the anti climbing device had two chicks in so it was not removed. The nest at 40m could not be removed as only EP has a mast climbing certificate.	EP, EM
20/06/2012	15:00-18:00	Navigation light reported not working	Positive wire to nav light had disconnected.	Re-wired, tightened other connections as well. Cleaned solar panels, checked general status of mast and instruments. Nest at 40m was removed	All else appeared to be ok	EP, HH
06/02/2013	8:00-12:00	Objective is to change 62m anemometer, do mast inspection, and take measurements of mast verticality with Leica Total Station	Solar panels very dirty; one cup of 62m had broken off; ends of some guy ropes bent at angle where they exit out of guy grips, due to sheep rubbing against guy rope anchors	Solar panels cleaned, and 62m anemometer (#7644) replaced with #7678. Guy rope ends tied up. Any rust on guy ropes sprayed with zinc-spray. Took mast verticality measurements.	Anemometer was not plugged in correctly, but started recording correctly on 20 Feb	EP, JK, PO
26/02/2013	08:30-12:00	To check 62m anemometer	Solar panels again full of bird droppings.	62m Anemometer unplugged and re-plugged, checked for correct operation. Branches with thorns tied above solar panels to prevent birds landing on solar panels	All else still working ok	EP, JK, SM

WM03 Station Logbook

Name of station: WM03 Vredendal	Location: 31°43'49.8246"S, 18°25'11.6976"E, 241 m A.S.L
Contact person: Eric Prinsloo	System serial / reference #: 490

Date	Time	Event	Observations	Actions	Comments	ID
24/06/2010	16:00	Instrument installation			Completed instrument installation	EP, EM, PT, SM
15/09/2010	15:50 – 16:50	Changed modem setup	Mast & Instrumentation looks ok	Changed modem setup to get powered though data logger	SAWA_0_6.CR1 was loaded onto data logger.	EP, JK
05/04/2011	8:00 – 12:00	Site Description visit	Mast and instrumentation still looks ok. Farm owner says that navigation light does not work. Newly installed 80m mast from Inca Energy is about 1km SE from WM03	Cleared bird droppings from solar panels. Clamped 20m WD along booms for less than 3 min	Nav light failure confirmed from other sources as well. Will be fixed during upcoming mast maintenance visits	EP, NM, SS, SM
04/02/2013	16:00 – 18:00	Site inspection visit, and mast measurements with Leica Total Station	Instruments ok, but nav light battery box badly corroded. Some superficial rust on shackles and turnbuckles	Scraped & brushed rust off nav light box, and sprayed with zinc-rich paint. Also sprayed shackles and turnbuckles. Took readings with Total Station.	Nav light box will need replacement within the next 12 months. Nav light not checked	EP, JK, PO

WM04 Station Logbook

Name of station: WM04 Vredenburg	Location: 32°50'46.7802"S, 18°06'33.1812"E , 22 m A.S.L
Contact person: Eric Prinsloo	System serial / reference #: 491

Date	Time	Event	Observations	Actions	Comments	ID
18/05/2010	18:30	Instrument installation			Completed instrument installation (involved were Risø technicians and Alpinist Safety Consultants, who assisted with instrument installations)	EP
24/05/2010	11:00	No comms with logger	Modem plug not properly connected	Re-connected modem plug and checked comms.		EP
30/09/2010	13:00 – 17:00	Site visit for video shoot with tv crew from e-tv			Eugene, Pieter and Eric	EP
04/04/2011	13:00 – 17:00	Site Description visit	Crow's nest just below 10m booms. Otherwise mast looks ok	Aligned and clamped clamped 20m WD between 15:10 and 15:40. Cleared nest away, and also cleaned bird droppings from solar panels	Modem still powered directly from battery, thus logger still using original SAWA_0_4.CR1 program	EP, NM, SS, SM & others
21/06/2012	12:00 - 16:00	Nav light not working	Nav light battery 7.83v, negative wire from solar panel had disconnected.	Re-connected and battery volts started to increase.	Farmer confirmed the next day that nav light was working	EP, HH
23/07/2012	10:00 – 17:00	Noticed from graphs that solar panel stopped working on 2 Jul.	Found that logger solar panel and solar panel, battery and regulator of nav light had been stolen. Nav light battery box lying on ground	Moved logger enclosure to 13m, and fitted wooden box for nav light battery at 14m. New solar panels for both mounted at ±16m. Fitted second anti-climbing frame at 6m, with razor wire wrapped around both.	No data was lost	EP, TH
17/09/2012	10:00 – 17:00	Solar panel stopped charging on 17 Aug. Farmer confirmed that solar panels are both missing.	Thieves were not perturbed by razor wire and second anti-climbing frame, and just cut through these to get to solar panels. Also broke open wooden box of nav light battery and removed battery.	Mounted solar panel for data logger, secured inside steel frame, at 30m. Fixed sheet metal cladding around 3-6m mast section to prevent climbing up mast. Removed lower anti-climbing frame.	No data lost	EP, TH

08/11/2012	10:00 – 17:00	To install new LED type B solar naviglights.	One D-shackle of 60m guy rope which was touching aluminium body of nav light was badly rusted.	Old nav light with bracket and cable removed & installed 2 LED type B self-containing nav lights at top of mast. One was installed at 59.5m, the other one at the top	Also checked verticality of instruments; all are ok. Did not have material to treat rusted D-shackle	EP, TH, PO
06/02/2013	18:00 – 20:00	To take verticality readings with Leica Total Station, treat rusted D-shackle from previous visit and also treat any turnbuckles and anchor units showing corrosion with zinc spray.	Had to make use of extension ladder to get to mast section above cladding.	Took verticality checks with Total Station. D-shackle sanded and treated with zinc spray. Also treated other corroded parts where possible. Cable-tied some loose cabling on mast. Crow's nest on platform was removed	Wind was quite strong during this period (15m/s)	EP, JK, PO
07/06/2013	15:00 – 18:00	Farmer phoned on morning of 7 th to say that mast has fallen over.	Inspection showed that mast guy ropes on NNW side of mast had been sawn through, allowing for mast to fall over in SSE direction. Most sensors broken, except 20m WD and WS. Logger enclosure broken into and battery removed. In process all cables were cut. Solar panel cut out of frame. SIM card in modem was also removed	Data logger enclosure and 20m sensors removed and brought back to Stb. Rest of mast to be removed when approval from insurers have been received. Case of malicious damage was registered with Vredenburg police.	Last data for WM04 was 22:40 on 6 June 2013. Insurance claim for mast was handed in	EP, TH
24/07/2013	10:00 – 16:00			Mast dismantled and everything brought back to Stell.		EP, TH, SH

WM05 Station Logbook

Name of station: WM05 Uitzicht	Location: 34°36'42.894"S, 19°41'32.8056"E , 288 m A.S.L
Contact person:	Station ID: 492

Date	Time	Event	Observations	Actions	Comments	ID
11/2/2010		15m Test mast instrumented.			Wind directions not aligned	kmen
20/4/2010		15m Test mast dismantled				Kmen
20/5/2010		60m Mast instrumented.		60m Anemometer cups damaged during installation (S/N 7658). Did not install.		Kmen
24/5-2010	9:00-12:30	60m anemometer needs to be replaced		Installed spare 60m anemometer #7237; station was switched off during this time	Used #7237 calibration values for 60m in RODEO	EricP
15/9-2010		QA	Bad temperature values (-40) up until 201005241250. Bad values (0) in 201005241240	Faulty values changed to Null in database tables for calibrated values.		kmen
7/10/2010	12:45		Photographs showed that 40 m anemometer actually sits at 37m.	Moved 40m anemometer boom from 36.25m up to 39.25m, to have cups at 40m	Data columns were adjusted to provide for both "40m" heights before and after adjustment of boom height	EP
7/10/2010	14:30	Modem modification	Data logger was down between 14:30 and 16:20; 40m anemometer was down from 12:45 to 14:45	Made modification to modem power supply to get its power from logger; upload program	Was not able to connect to logger with notebook. Had to upload SAWA_0_6.CR1 to logger via GSM.	EP
05/04/2011	12:00-14:30	Site inspection visit		Aligned and clamped 20m WD between 12:30 and 13:10		PT, TH, JCH
28/06/2011	13:00-15:00	62m Anemometer appears faulty before this date	General wind speeds at time of visit were 4m/s, but primary anemometer did not turn	Replaced S/N 7659 with re-furbished and re-calibrated S/N 7661. Logger was <u>not</u>	Calibration figures for #7661 implemented in database. Data for S/N 7659 deleted	EP, PO

			at all	switched off during this time	from 9:00 on 13 Jun to 13:00 on 28 Jun. Have to check correlation between 60m and 62m before 13 Jun as well	
12/04/2012	09:00 – 16:00	20m Anemometer needs to be replaced. Also take boom direction readings.	Cups of anemometer not turning at all. Nav light not working	20m Anemometer #7656 was replaced with #7676. 20m Data from 8:00 on 31 Mar to 10:50 on 12 Apr deleted. Nav light solar controller was replaced. Boom direction readings were taken	Ave. Compass readings of booms to North was 25.6°, and from South 205.75°.	EP, PO
23/01/2013	10:00 – 15:00	40m Anemometer not working	Cups not turning at all. Some corrosion on turnbuckles, D-shackles, and on 60m cables. 20m Anemometer leaning over by about 1° to the East; adjusted to vertical again.	Replaced 40m anemometer #7657 with #7658. Sanded & brushed the corroded D-shackles on the mast and sprayed with zinc-spray. Also sprayed guy rope turnbuckles where required.	Rest of mast and instruments look ok.	EP, PO
27/02/2013	19:00 – 21:00	To check mast verticality with Leica Total Station	Nav light still working. Very strong wind.	Some broken cable ties were replaced. Took verticality checks on mast from 2 sides, got too dark to see crosshairs on sighter.	Quite strong wind blowing (17m/s)	EP, JK, SM

WM06 Station Logbook

Name of station: WM06 Sutherland	Location: -32° 33' 24.4728" S, 20° 41' 28.4748" E, 1581 m A.S.L
Contact person: Eric Prinsloo	System serial / reference #: 493

Date	Time	Event	Observations	Actions	Comments	ID
17/09/2010	15:30	Instrument installation 20m Anemometer cups S/N 7661 damaged during installation		Replaced S/N 7661 with spare S/N 7238	Completed instrument installation. S/N 7238 calibration values applied to database Operating on SAWA_0_6.CR1	EP
07/04/2011	15:00 – 17:00	Site Description visit		Aligned and clamped 20m WD between 10:50 and 11:30		PT, TH, JCH
14/04/2011	11:00	No comms with modem after site visit	Modem plug not connected to data logger	Connected modem plug	Comms with logger working again	EP, PT
03/08/2012	11:00 – 13:00	40m & 20m Anemometers are recording lower values than normal	One cup of each of the 20m and 40m anemometers missing. Very heavy snowfall on 13 & 14 Jul, causing anemometers to freeze up. Blocks of thawing snow must have fallen onto the 40m and 20m anemometers, breaking off the cups	Replaced 40m anemometer #7662 with #7680, and 20m anemometer #7238 with #7679. Checked data, looked realistic, with descending speeds from 62m to 10m	Mast and instruments still look good	EP, TH, JK
26/02/2013	16:00 – 19:00	Site inspection visit, and to take verticality readings with Leica Total Station	No visible rust on mast and guy ropes. Mast in excellent condition. No bird nests. Nav light is working	Took verticality readings with Leica Total Station. Replace a number of broken cable ties	Station looks good	EP, JK, SM

WM07 Station Logbook

Name of station: WM07 Beaufort West	Location: -32° 58' 0.2028" S, 22° 33' 24.012" E, 1047 m A.S.L
Contact person: Eric Prinsloo	System serial / reference #: 494

Date	Time	Event	Observations	Actions	Comments	ID
28/05/2010	15:30	Instrument installation	Very strong winds during installation, 8°C ambient temp.		Completed instrument installation	EP
05/07/2010	10:00	Modem failed	No connection with modem	Unplugged, and re-plugged power cable to modem	Communication ok again	EP
14/12/2010	10:00	Modem again faulty	No connection with modem	Changed modem, and did power supply conversion to power modem via data logger.	Uploaded SAWA_0_6.CR1 to data logger via server	EP, TH
06/04/2011	09:00 – 12:00	Site Description visit	Clear single birds nest from mast just above 20m booms	Aligned and clamped 20m WD between 10:50 and 11:20		EP, TH
27/02/2013	12:00 15:00	Site inspection visit and do verticality check with Leica Total Station	Nest next to nav light on top of mast, and one on frame. Also nest behind logger enclosure. Solar panels covered in bird droppings. Broken cable ties. No rust on D-shackles but turnbuckle on each 48m guy rope was slightly rusted	All noticeable rust spots were treated with zinc spray. Took readings with Leica Total Station. Broken cable ties replaced. Mounted thorn branches on top of solar panels to prevent birds landing on them. All nests were removed	Nav light is working.	EP, JK, SM
29/04/2013	13:00 – 14:30	Replace 62m anemometer	One cup broken off. Was damaged in hailstorm on 27 Mar. Data from then to 29 Apr to be deleted	Replaced anemometer #7669 with #7656. Fitted bird spike to data logger's solar panel	Data from 17:40 on 27 Mar to 14:00 on 29 Apr was deleted	EP,JK,SM

WM08 Station Logbook

Name of station: WM08 Humansdorp	Location: -34° 06' 35.874" S, 24° 30' 51.6954" E, 110 m A.S.L
Contact person: Eric Prinsloo	System serial / reference #: 495

Date	Time	Event	Observations	Actions	Comments	ID
04/08/2010	14:00	Instrument installation			Completed instrument installation. Modem modification done before instrument installation and logger uploaded with SAWA 0 5.CR1 . This was before it was discovered that SAWA_0_5.CR1 does not switch off the modem just after midnight. However modem gave no problems so program was left as is. WM8 is only station with SAWA_0_5.CR1	EP
23/06/2011	14:00 – 17:00	Site Description visit	Station seems ok, guy rope foundations ok. Anchors and mast fenced off. Dead Kori bustard bird lying below mast, probably flew into guy ropes	20m WD sensor clamped in line with boom. Clamped time less than 3min.		EP, EM
02/05/2013	10:00 – 15:00	Site inspection visit, and to change 62m anemometer	Turnbuckles are some quite rusted, as well as some parts of upper guy ropes. One upper orange buoy was halfway dislodged from cable. Nav light not working, according to locals. Checked that solar controller is working. Photocell in nav light housing is corroded, and apparently the problem why light does not switch on. The fences around the mast and guy rope foundations will need repairing again	Photocell of nav light was bypassed, but then nav light flashes continuously. Left it like that to sort out at a later date. Replaced 62m anemometer #7675 with #7677. Sprayed rusted turnbuckles and D-shackles with zinc-spray. Tied loose buoy up with cable ties again. One section of upper guy rope is quite corroded, and issue will be taken up with Webb LeBlanc	Farmer confirmed after a couple of days that nav light stopped working. We will get a new solar controller, pair up with the ex-WM10 nav light, make sure it's working correctly and install at a later date. Managing Director of Watt Energy, owner of farm where mast resides, will arrange that fences around mast and foundations will be fixed.	EP, JK, SM
16/05/2013	11:00 - 13:00	To swap standard dual nav light with one that is working		Nav light was replaced, and checked for correct operation by covering solar panel to simulate dusk.	Nav light working, confirmed with farmer nearby who checked during the night	TH, JK

WM09 Station Logbook

Name of station: WM09 Noupoot	Location: -31° 15' 09.1434" S, 25° 01' 42.1674" E, 1806 m A.S.L
Contact person: Eric Prinsloo	System serial / reference #: 498

Date	Time	Event	Observations	Actions	Comments	ID
01/09/2010	16:00	Instrument installation			Completed instrument installation	EP, EM, PT, SM
01/09/2010	08:00-14:00	Very poor modem comms.	Mast is directly between antenna and cell phone tower 10km away	Shifted boom with antenna (and 10m Tgrad) to point towards TN instead of 60°, which was ± in line with mast and cell phone tower	Comms better, but signal still very weak.	EP, EM, PT, SM
14/09/2010	09:00	Erratic modem connection		Installed Yagi directional antenna at 11.7m. Also installed new modem and uploaded SAWA_0_6.CR1 via server	Comms much better	EP, JK
22/06/2011	15:00 – 17:00	Site Description visit	Station seems ok, guy ropes tight. No bird nests.	Clamped 20m WD in line with boom, lasting not longer than 3 min.		JCH, PT, TH
24-25/07/2011		Reports of heavy snow falls in NE Cape	On 25 Jul anemometers start failing one after the other from top to bottom			EP
26/07/2011		No wind speed data, only temp and pressure data looks ok up to 9:40 on 26th. Rh 100% since day before	No comms with logger after 10:00, even though signal strength to modem is good		All mountain passes and main roads to Noupoot closed for a week, so could only visit site on 16 Aug	EP
16/08/2011	10:00 – 14:00	Field visit to WM9, using different approach route. Still need to walk 1.8km to mast	Mast broken, lower 27m still upright, the top 33m has toppled over, snapping off at 36m and at 27m. All anemometers damaged, each with at least one cup broken off. Also 60m WD damaged beyond repair. Solar panel smashed, cables of junction box severed, as well as that of 40m anemometer and 60m T-grad.	Removed all instruments, together with logger box and remaining cables to bring back to St'bosch	Set all sensors up in lab to test whether they still work (for testing anemometers, old cups were glued in place). Only 60m WD sensor broken. Anemometers, Rh/temp, T-grad still working ok. Anemometers will require new cups and re-calibration.	EP, PT

10-14/12/2011		New mast being installed. Mast manufactured from grade 355 material, as per designer specs.		Same mast configuration used	Certificate of Conformance was issued by mast engineer. The guy grips were now clamped with Crosby clamps to prevent similar ice-loading damage	
21 – 22/12/2012		Re-install instrumentation onto mast.	No lightning spike installed on mas. Different type of nav. light (Type A), one at 60m and an additional one on 30m	Fitted new anemometers at 62m = #12242, 60m = #12241 while rest were refurbished and re-calibrated ones; 40m = #7659, 20m = #502, 10m = #501. A new WD sensor was also installed, as well as the spare 70m junction box cable we had. Old lightning spike was straightened, welded up, and re-installed. Booms were fitted within 2-3cm of original heights	Mast trap door was installed later by mast company, as well as new ID plate. Station data checked and everything download ok.	EP, EM, PT, SM
30/04/2013	08:30 – 15:00	Site inspection visit, install original dual type B nav lights, and take verticality measurements with Leica Total Station.	Solar panels quite clean. Very few rust spots, Guy rope ends, which were now tied up with Crosby clamps, splayed open possibly due to accumulated ice blocks sliding down guy rope. Fortunately Crosby clamps prevented guy grips from being dislodged again	Replaced two 10 candela LED nav lights with original Type B lights. Fitted nav light battery box at 25m. Took Leica measurements.	Could not check if nav lights are working. Instruments and rest of mast looks fine.	EP, JK2, SM

WM10 Station Logbook

Name of station: WM10 Butterworth	Location: -32° 05' 26.3394" S, 28° 08' 09.42" E, 925 m A.S.L
Contact person: E Prinsloo	System serial / reference #: 499

Date	Time	Event	Observations	Actions	Comments	ID
05/08/2010		Instrument installation			Completed instrument installation	EP
24 Nov 2010		Solar panel stolen	Data logger stopped working 29 Dec 2011		Data from 29 Dec to 17 Jan lost, as we did not regularly check the graphs showing battery volts	EP
17 Jan 2011				Replaced solar panel, but mounted new one at 17m height. Installed new battery	Wrapped razor wire around bottom of mast and around anti-climbing device. Attached notice in IsiXhosa about WASA project to mast	EP, PT
4 Mar 2011		Data from 40m, 20, 10m anemometers stopped, as well as temp grad.				EP
8Mar 2011		Had Pta operator reload SAWA_6_CR1 to logger to see if that wouldn't solve the problem	Data now only every 30min, Operator selected "last data" on Loggernet instead of "all data since last download", but we did not realise that until the 17 th .			EP
15 Mar 2011		Our contact at Butterworth informed us that station was vandalised	Visited site, found cables of 10m, 20m, 40m anemometers were cut, as well as T-grad cables and antenna cable. Apparent attempts to open logger box as well	Moved logger box to 9m. Joined cut cables and restarted logger. NB Connector plugs of anemometers inadvertently swopped around. 10m anemometer outputs as 20m in data; 20m anemometer outputs as 40m in data, and 40m anemometer outputs as 10m in data. Only realised this when data was checked after downloading on 21/6	Still only 30min values. Operator again asked to upload SAWA_0_6.CR1 program but he again selected "last data" instead of "all data since last download" and did not notify us. Correct readings were applied in RODEO so that the correct heights are reflected in the correct data columns	EP, TH

16 Mar 2011		Existing logger data still showing only 30min value recordings in data downloads		Swapped data loggers (S/N E3894/SN24499 for E3994/SN25531) and also moved flash card recorder to new logger. New flash card could however not initialise	Could not connect to logger with pc to set new baud rate, so no modem connection, and no data download to server. Also reported case of theft of cable to local police Data with 30min recordings from 8 Mar to 17 Mar removed from database	EP
21/06/2011	11:00-15:00	Site Description visit	Station seems ok, guy ropes ok. No bird nests. Cattle seem to be rubbing against guy ropes	Clamped 20m WD in line with boom, lasting not longer than 3 min. Downloaded data from logger using notebook (3 months of data)	Still could not get memory card to initialise	EP
29/06/2011	11:30-18:30	Logger change visit		Changed data loggers ((S/N E3994/SN25531 replaced by E3894/SN24499, - which is original WM10 logger) Also tied lengths of pvc tubing around lower ends of guy ropes	Logger and modem connection now sorted out, as well as remote data downloading.	EP, TH
15/05/2012	12:00 – 17:00	Vandalism reported Objective is to install new CR200 data logger with enclosure at top of mast, and only keep upper instruments. Remove 10m, 20, and 40m sensors.	Original data logger enclosure had been stolen, with all cables entering it been hacked off. Both solar panels have been stolen, as well as the battery of the nav light, of which the battery box was lying on the ground	Mounted CR200 logger in enclosure at 57m, with 12Ahr battery and 10A solar panel on top of enclosure. Kept only 62m & 60m anemometers, Temp/Rh, 60m W/dir, and barometric pressure. Removed 40m, 20m and 10m.instruments and booms	Data logger stopped recording on 28 Feb, but contact in Butterworth could only get to site 3 weeks later to confirm the theft and vandalism. While on site we found the old logger enclosure minus battery about 150m from mast. Four days later the CR200 logger stooped working. We have to go back to install new LED nav lights, and will then install the old data logger again. Attached Crosby clamps onto guy grips so that these can't be unwound by cattle rubbing against them	EP, TH, PO
11/07/2012	9:00 – 17:00	To install new LED nav lights, and to swop CR200 data logger for original WM10 data logger.	No further vandalism to mast. Unfortunately we could not download any data from CR200, and we also had to use the CR200 with its built-in regulator, as we did not have a standard solar regulator with us.	Swapped CR200 data logger with original CR1000. This included a bigger enclosure for the CR1000 logger. Installed new LED navigation lights. Wrapped razor wire around mast at 30m.	With next visit a proper solar regulator must be installed, and CR200 brought back. Rh sensor is starting to pack up	EP, PT, SM
1/05/2013	10:00	Do site inspection, and do verticality check with Leica Total Station. Swop Rh sensor. Install new solar regulator	Checked LED nav lights, one not working, battery pack volts is down. Used battery pack from one of the WM09 LED lights as a replacement. Some Crosby clamps and turnbuckles are rusted	Changed Rh sensor #E2620011 with #E2620016. Installed correct solar regulator and removed CR200 data logger. Fixed nav light. Treated rust spots with zinc spray. Took readings with Total Station	Instruments look ok, mast also still in good condition. Continuous problem of domestic stock rubbing against guy ropes and mast. WD and WS sensors briefly disconnected from junction box to re-arrange wiring setup	EP, JK, SM

ANNEXURE E

Data Statistics

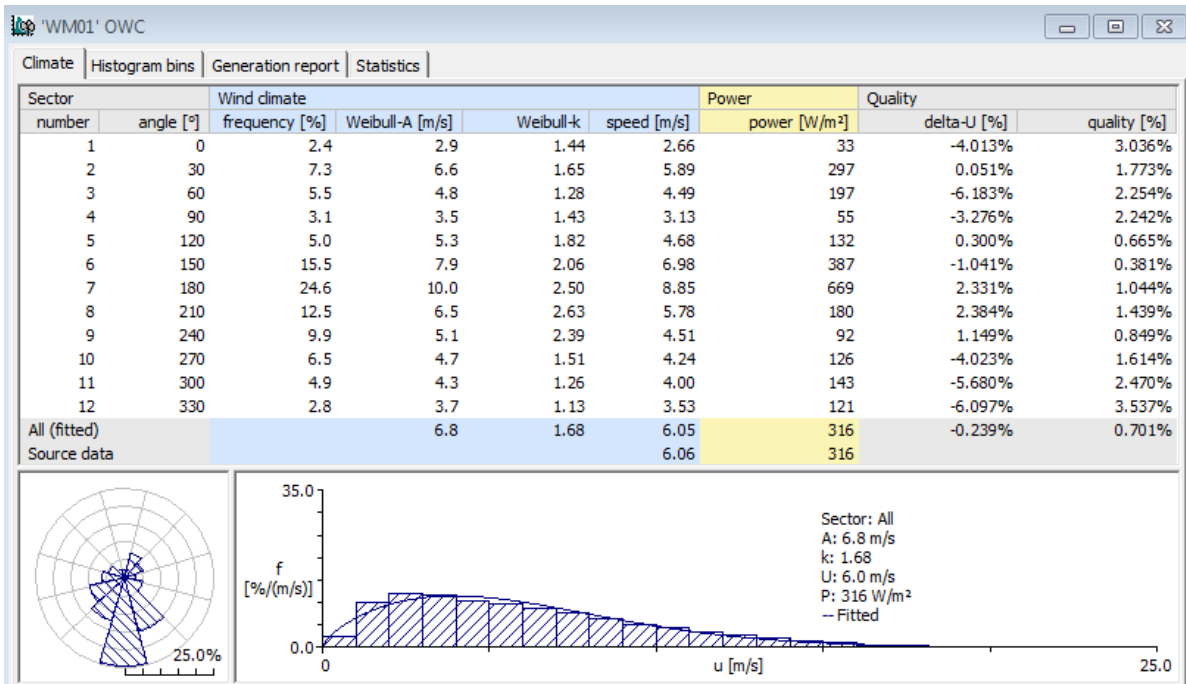

WM01' OWC

Climate | Histogram bins | Generation report | Statistics

Climate generation
 Generated at: 14/05/2014 12:05:00
 Generated using: WASP Climate Analyst (using Rvea0073) version: 2.00.0132
 Generated by: nimo on VINDRI-L17131
 Number of data sets: 4
 Source file path: D:\Countries\South Africa\WASA\Data\SA01

	All Data Summary	Data set 1	Data set 2	Data set 3	Data set 4
File information:					
Source file name:		WM01_2010.csv	WM01_2011.csv	WM01_2012.csv	WM01_2013.csv
Last modified:		2011-07-14 22:35:57	2012-04-02 10:24:07	2013-05-21 14:27:14	2013-10-07 16:15:50
Protocol:		'Protocol created for importing downloaded data' (WASA)	'Protocol created for importing downloaded data' (WASA)	'Protocol created for importing downloaded data' (WASA)	'Protocol created for importing downloaded data' (WASA)
Recordings in file:					
Count:	175392	30816	52560	52704	39312
Start time:	2010-06-01 00:10:00	2010-06-01 00:10:00	2011-01-01 00:10:00	2012-01-01 00:10:00	2013-01-01 00:10:00
End time:	2013-10-01 00:00:00	2011-01-01 00:00:00	2012-01-01 00:00:00	2013-01-01 00:00:00	2013-10-01 00:00:00
Recordings used:					
Count:	157824	13248			
Start time:	2010-10-01 00:10:00	2010-10-01 00:10:00	All recordings examined	All recordings examined	All recordings examined
End time:	2013-10-01 00:00:00	2011-01-01 00:00:00			
Mean wind speed ('U_62') data:					
Readings below lower limit (0):	1 (0.0%)	none	none	1 (0.0%)	none
Readings above upper limit (90):	none	none	none	none	none
Calms (speeds below 0.5 m/s):	575 (0.36%)	22 (0.17%)	154 (0.29%)	228 (0.43%)	171 (0.43%)
Valid readings accepted:	157823 (89.98%)	13248 (42.99%)	52560 (100.0%)	52703 (100.0%)	39312 (100.0%)
Accepted values range:	0.00 m/s to 22.53 m/s	0.00 m/s to 20.01 m/s	0.00 m/s to 22.53 m/s	0.00 m/s to 20.96 m/s	0.00 m/s to 20.13 m/s
Mean wind direction ('D_60') data:					
Readings below lower limit (0):	1 (0.0%)	none	none	1 (0.0%)	none
Readings above upper limit (360):	none	none	none	none	none
Calms (speeds below 0.5 m/s):	575 (0.36%)	22 (0.17%)	154 (0.29%)	228 (0.43%)	171 (0.43%)
Valid readings accepted:	157823 (89.98%)	13248 (42.99%)	52560 (100.0%)	52703 (100.0%)	39312 (100.0%)
Accepted values range:	0.0° to 360.0°	0.1° to 359.5°	0.0° to 360.0°	0.0° to 360.0°	0.0° to 360.0°
Data recovery:					
Expected recording count:	157824	13248	52560	52704	39312
Count of recordings in file:	175392 (111.13%)	30816 (232.61%)	52560 (100.0%)	52704 (100.0%)	39312 (100.0%)
Recordings with invalid values in one or more fields:	1 (0.0%)	0 (0.0%)	0 (0.0%)	1 (0.0%)	0 (0.0%)
Entirely valid recordings accepted:	157823 (89.98%)	13248 (42.99%)	52560 (100.0%)	52703 (100.0%)	39312 (100.0%)
Recovery percentage (vs. expected):	100.0%	100.0%	100.0%	100.0%	100.0%

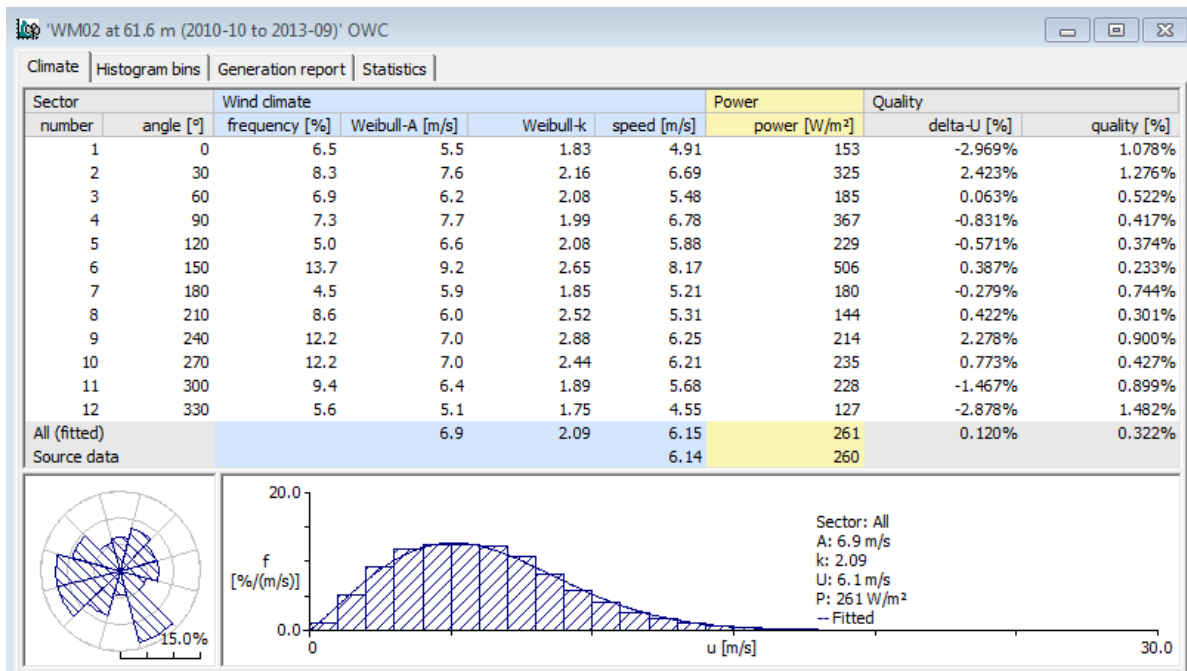

Climate generation
 Generated at: 14/05/2014 13:18:11
 Generated using: WASP Climate Analyst (using Rvea0073) version: 2.00.0132
 Generated by: nimo on VINDRI-L17131
 Number of data sets: 4
 Source file path: D:\Countries\South Africa\WASA\Data\SA02

	All Data Summary	Data set 1	Data set 2	Data set 3	Data set 4
File information:					
Source file name:		WM02_2010.csv	WM02_2011.csv	WM02_2012.csv	WM02_2013.csv
Last modified:		2011-07-14 22:37:40	2012-07-05 11:22:28	2013-05-21 18:39:17	2013-10-10 09:32:36
Protocol:		'Protocol created for importing downloaded data' (WASA)	'Protocol created for importing downloaded data' (WASA)	'Protocol created for importing downloaded data' (WASA)	'Protocol created for importing downloaded data' (WASA)
Recordings in file:					
Count:	175392	30816	52560	52704	39312
Start time:	2010-06-01 00:10:00	2010-06-01 00:10:00	2011-01-01 00:10:00	2012-01-01 00:10:00	2013-01-01 00:10:00
End time:	2013-10-01 00:00:00	2011-01-01 00:00:00	2012-01-01 00:00:00	2013-01-01 00:00:00	2013-10-01 00:00:00
Recordings used:					
Count:	157824	13248			
Start time:	2010-10-01 00:10:00	2010-10-01 00:10:00	All recordings examined	All recordings examined	All recordings examined
End time:	2013-10-01 00:00:00	2011-01-01 00:00:00			
Mean wind speed ('U_62') data:					
Readings below lower limit (0):	10492 (5.98%)	none	1 (0.0%)	3284 (6.23%)	7207 (18.33%)
Readings above upper limit (90):	none	none	none	none	none
Calms (speeds below 0.5 m/s):	172 (0.12%)	4 (0.03%)	75 (0.14%)	67 (0.14%)	26 (0.08%)
Valid readings accepted:	147332 (84.0%)	13248 (42.99%)	52559 (100.0%)	49420 (93.77%)	32105 (81.67%)
Accepted values range:	0.00 m/s to 25.36 m/s	0.00 m/s to 19.69 m/s	0.00 m/s to 22.70 m/s	0.00 m/s to 25.36 m/s	0.00 m/s to 19.94 m/s
Mean wind direction ('D_60') data:					
Readings below lower limit (0):	3 (0.0%)	none	1 (0.0%)	2 (0.0%)	none
Readings above upper limit (360):	none	none	none	none	none
Calms (speeds below 0.5 m/s):	172 (0.11%)	4 (0.03%)	75 (0.14%)	67 (0.13%)	26 (0.07%)
Valid readings accepted:	157821 (89.98%)	13248 (42.99%)	52559 (100.0%)	52702 (100.0%)	39312 (100.0%)
Accepted values range:	0.0° to 360.0°	0.1° to 360.0°	0.0° to 360.0°	0.0° to 360.0°	0.0° to 360.0°
Data recovery:					
Expected recording count:	157824	13248	52560	52704	39312
Count of recordings in file:	175392 (111.13%)	30816 (232.61%)	52560 (100.0%)	52704 (100.0%)	39312 (100.0%)
Recordings with invalid values in one or more fields:	10492 (5.98%)	0 (0.0%)	1 (0.0%)	3284 (6.23%)	7207 (18.33%)
Entirely valid recordings accepted:	147332 (84.0%)	13248 (42.99%)	52559 (100.0%)	49420 (93.77%)	32105 (81.67%)
Recovery percentage (vs. expected):	93.35%	100.0%	100.0%	93.77%	81.67%

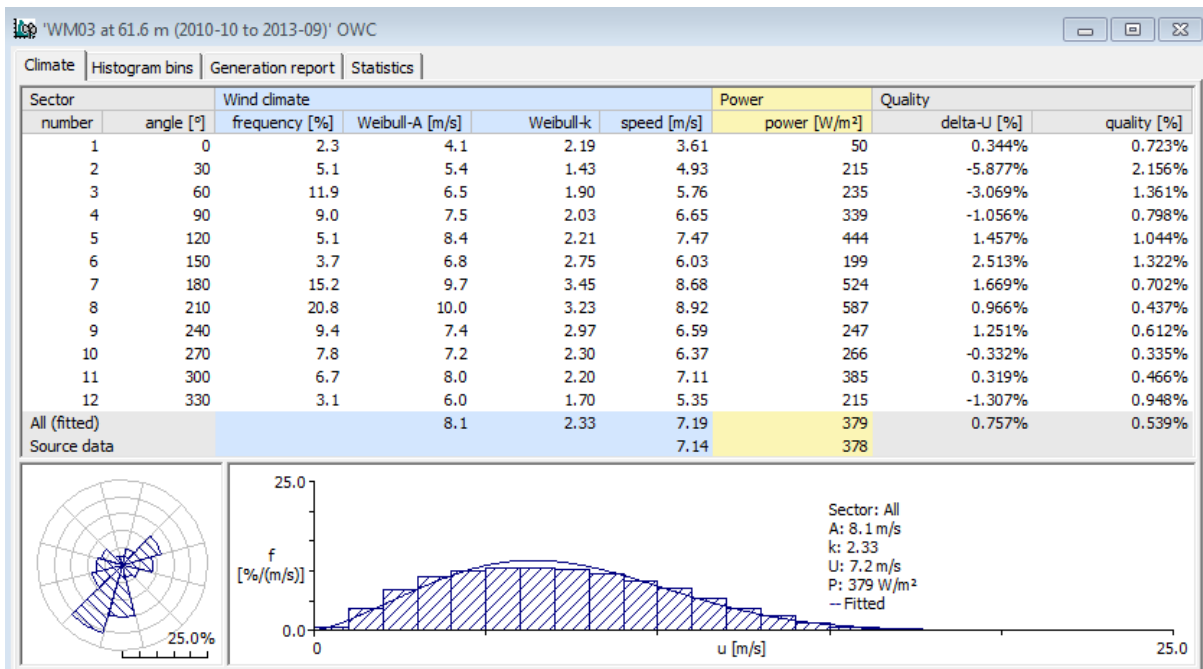

The screenshot displays the 'Climate generation' report for 'WM03 at 61.6 m (2010-10 to 2013-09)' OWC. The report includes generation details, file information, recordings in file, recordings used, and data quality statistics for mean wind speed and direction.

Climate generation
 Generated at: 14/05/2014 14:31:12
 Generated using: WAsP Climate Analyst (using Rvea0073) version: 2.00.0132
 Generated by: nimo on VINDRI-L17131
 Number of data sets: 4
 Source file path: D:\Countries\South Africa\WASA\Data\SA03

	All Data Summary	Data set 1	Data set 2	Data set 3	Data set 4
File information:					
Source file name:		WM03_2010.csv	WM03_2011.csv	WM03_2012.csv	WM03_2013.csv
Last modified:		2011-07-14 22:38:27	2012-07-05 11:28:03	2013-05-21 19:12:09	2013-10-10 16:25:06
Protocol:		'Protocol created for importing downloaded data' (WASA)	'Protocol created for importing downloaded data' (WASA)	'Protocol created for importing downloaded data' (WASA)	'Protocol created for importing downloaded data' (WASA)
Recordings in file:					
Count:	175392	30816	52560	52704	39312
Start time:	2010-06-01 00:10:00	2010-06-01 00:10:00	2011-01-01 00:10:00	2012-01-01 00:10:00	2013-01-01 00:10:00
End time:	2013-10-01 00:00:00	2011-01-01 00:00:00	2012-01-01 00:00:00	2013-01-01 00:00:00	2013-10-01 00:00:00
Recordings used:					
Count:	157824	13248			
Start time:	2010-10-01 00:10:00	2010-10-01 00:10:00	All recordings examined	All recordings examined	All recordings examined
End time:	2013-10-01 00:00:00	2011-01-01 00:00:00			
Mean wind speed ('U_62') data:					
Readings below lower limit (0):	none	none	none	none	none
Readings above upper limit (90):	none	none	none	none	none
Calms (speeds below 0.5 m/s):	106 (0.07%)	5 (0.04%)	41 (0.08%)	28 (0.05%)	32 (0.08%)
Valid readings accepted:	157824 (89.98%)	13248 (42.99%)	52560 (100.0%)	52704 (100.0%)	39312 (100.0%)
Accepted values range:	0.00 m/s to 23.92 m/s	0.00 m/s to 16.99 m/s	0.00 m/s to 20.92 m/s	0.00 m/s to 23.92 m/s	0.00 m/s to 20.28 m/s
Mean wind direction ('D_60') data:					
Readings below lower limit (0):	none	none	none	none	none
Readings above upper limit (360):	none	none	none	none	none
Calms (speeds below 0.5 m/s):	106 (0.07%)	5 (0.04%)	41 (0.08%)	28 (0.05%)	32 (0.08%)
Valid readings accepted:	157824 (89.98%)	13248 (42.99%)	52560 (100.0%)	52704 (100.0%)	39312 (100.0%)
Accepted values range:	0.0° to 360.0°	0.1° to 359.9°	0.0° to 360.0°	0.0° to 359.9°	0.0° to 360.0°
Data recovery:					
Expected recording count:	157824	13248	52560	52704	39312
Count of recordings in file:	175392 (111.13%)	30816 (232.61%)	52560 (100.0%)	52704 (100.0%)	39312 (100.0%)
Recordings with invalid values in one or more fields:	0 (0.0%)	0 (0.0%)	0 (0.0%)	0 (0.0%)	0 (0.0%)
Entirely valid recordings accepted:	157824 (89.98%)	13248 (42.99%)	52560 (100.0%)	52704 (100.0%)	39312 (100.0%)
Recovery percentage (vs. expected):	100.0%	100.0%	100.0%	100.0%	100.0%

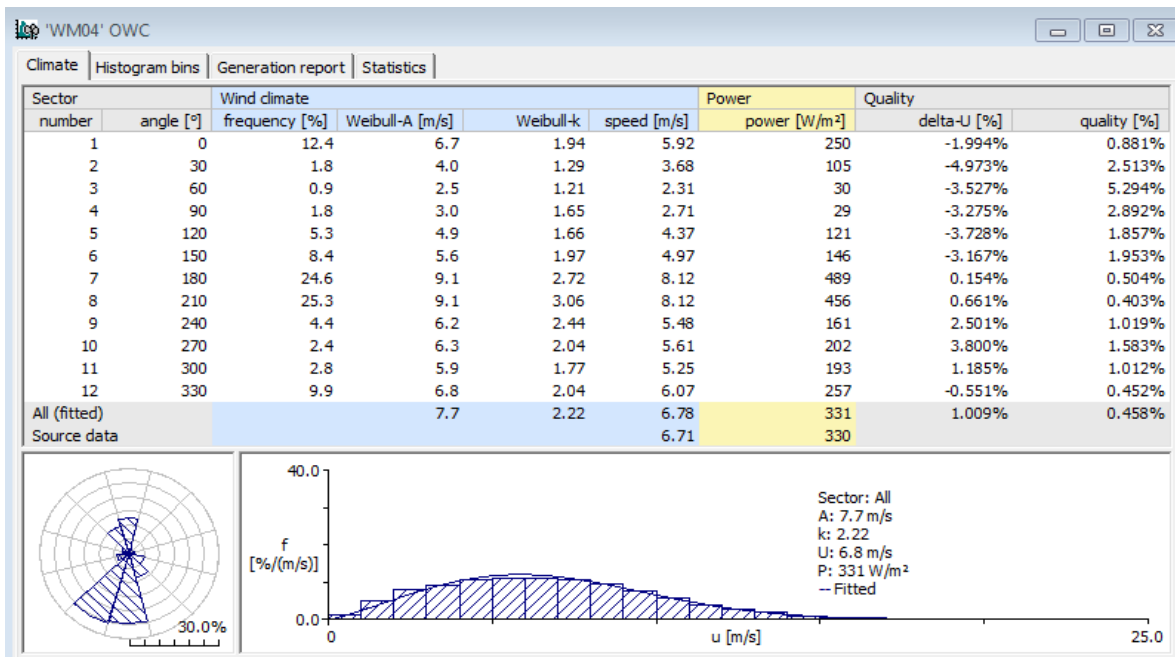

Climate generation

Generated at: 29/09/2013 00:23:35
 Generated using: WASP Climate Analyst (using Rvea0073) version: 2.00.0132
 Generated by: nimo on RI-L14228
 Number of data sets: 4
 Source file path: D:\Countries\South Africa\WASA\Data\SA04

	All Data Summary	Data set 1	Data set 2	Data set 3	Data set 4
File information:					
Source file name:		WM04_2010.csv	WM04_2011.csv	WM04_2012.csv	WM04_2013.csv
Last modified:		2011-07-14 23:04:41	2012-07-31 12:29:54	2013-05-21 22:32:29	2013-09-29 00:20:23
Protocol:		'Protocol created for importing downloaded data' (WASA)	'Protocol created for importing downloaded data' (WASA)	'Protocol created for importing downloaded data' (WASA)	'Protocol created for importing downloaded data' (WASA)
Recordings in file:					
Count:	166608	35280	52560	52704	26064
Start time:	2010-05-01 00:10:00	2010-05-01 00:10:00	2011-01-01 00:10:00	2012-01-01 00:10:00	2013-01-01 00:10:00
End time:	2013-07-01 00:00:00	2011-01-01 00:00:00	2012-01-01 00:00:00	2013-01-01 00:00:00	2013-07-01 00:00:00
Recordings used:					
Count:	157824	30816			21744
Start time:	2010-06-01 00:10:00	2010-06-01 00:10:00	All recordings examined	All recordings examined	2013-01-01 00:10:00
End time:	2013-06-01 00:00:00	2011-01-01 00:00:00			2013-06-01 00:00:00
Mean wind speed ('U_62') data:					
Readings below lower limit (0):	3 (0.0%)	3 (0.01%)	none	none	none
Readings above upper limit (90):	none	none	none	none	none
Calms (speeds below 0.5 m/s):	301 (0.19%)	75 (0.24%)	100 (0.19%)	109 (0.21%)	17 (0.08%)
Valid readings accepted:	157821 (94.73%)	30813 (87.34%)	52560 (100.0%)	52704 (100.0%)	21744 (83.43%)
Accepted values range:	0.00 m/s to 21.64 m/s	0.00 m/s to 20.33 m/s	0.00 m/s to 19.28 m/s	0.00 m/s to 21.64 m/s	0.00 m/s to 19.69 m/s
Mean wind direction ('D_60') data:					
Readings below lower limit (0):	3 (0.0%)	3 (0.01%)	none	none	none
Readings above upper limit (360):	none	none	none	none	none
Calms (speeds below 0.5 m/s):	301 (0.19%)	75 (0.24%)	100 (0.19%)	109 (0.21%)	17 (0.08%)
Valid readings accepted:	157821 (94.73%)	30813 (87.34%)	52560 (100.0%)	52704 (100.0%)	21744 (83.43%)
Accepted values range:	0.0° to 360.0°	0.0° to 360.0°	0.0° to 360.0°	0.0° to 360.0°	0.0° to 360.0°
Data recovery:					
Expected recording count:	157824	30816	52560	52704	21744
Count of recordings in file:	166608 (105.57%)	35280 (114.49%)	52560 (100.0%)	52704 (100.0%)	26064 (119.87%)
Recordings with invalid values in one or more fields:	3 (0.0%)	3 (0.01%)	0 (0.0%)	0 (0.0%)	0 (0.0%)
Entirely valid recordings accepted:	157821 (94.73%)	30813 (87.34%)	52560 (100.0%)	52704 (100.0%)	21744 (83.43%)
Recovery percentage (vs. expected):	100.0%	99.99%	100.0%	100.0%	100.0%

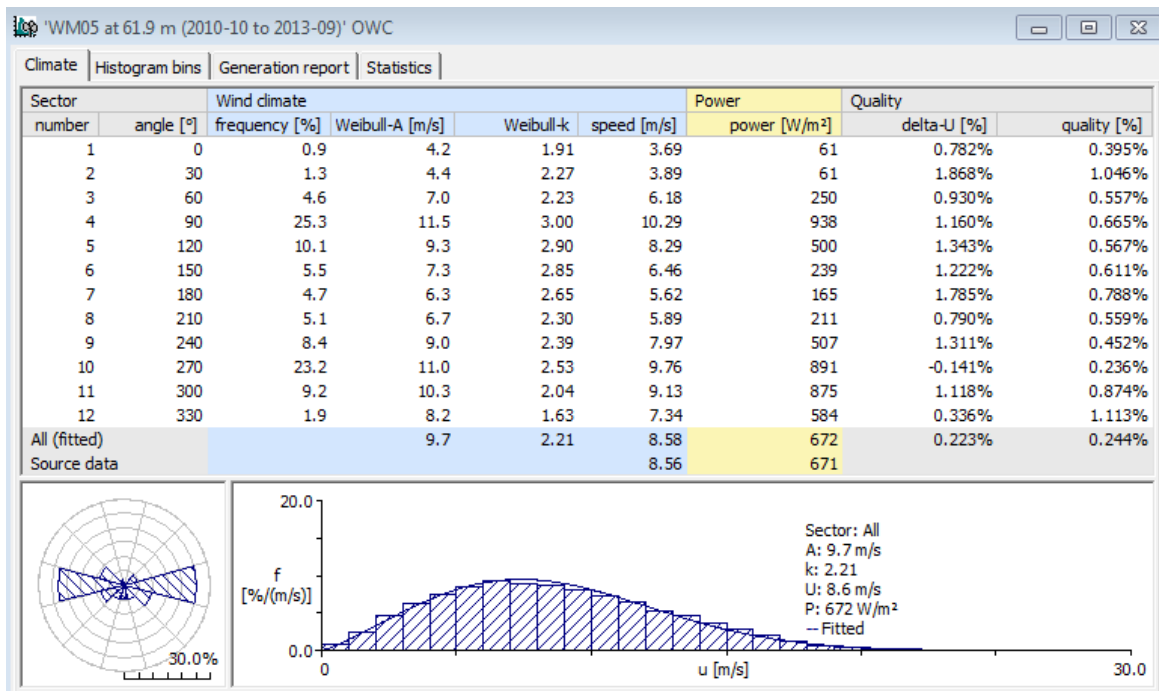

The figure displays a software window titled 'WM05 at 61.9 m (2010-10 to 2013-09)' OWC. It features a navigation bar with 'Climate', 'Histogram bins', 'Generation report', and 'Statistics'. Below this is a 'Climate generation' section with metadata. The main part of the window is a detailed data summary table with columns for 'All Data Summary', 'Data set 1', 'Data set 2', 'Data set 3', and 'Data set 4'. The table includes sections for File information, Recordings in file, Recordings used, Mean wind speed ('U_62') data, Mean wind direction ('D_60') data, and Data recovery.

Climate generation
 Generated at: 14/05/2014 23:38:44
 Generated using: WASP Climate Analyst (using Rvea0073) version: 2.00.0132
 Generated by: nimo on VINDRI-L17131
 Number of data sets: 4
 Source file path: D:\Countries\South Africa\WASA\Data\SA05

	All Data Summary	Data set 1	Data set 2	Data set 3	Data set 4
File information:					
Source file name:	WM05_2010.csv	WM05_2011.csv	WM05_2012.csv	WM05_2013.csv	WM05_2013.csv
Last modified:	2011-08-26 12:39:23	2012-08-01 10:11:02	2013-05-21 23:13:14	2013-10-10 18:42:57	2013-10-10 18:42:57
Protocol:		'Protocol created for importing downloaded data' (WASA)	'Protocol created for importing downloaded data' (WASA)	'Protocol created for importing downloaded data' (WASA)	'Protocol created for importing downloaded data' (WASA)
Recordings in file:					
Count:	179856	35280	52560	52704	39312
Start time:	2010-05-01 00:10:00	2010-05-01 00:10:00	2011-01-01 00:10:00	2012-01-01 00:10:00	2013-01-01 00:10:00
End time:	2013-10-01 00:00:00	2011-01-01 00:00:00	2012-01-01 00:00:00	2013-01-01 00:00:00	2013-10-01 00:00:00
Recordings used:					
Count:	157824	13248			
Start time:	2010-10-01 00:10:00	2010-10-01 00:10:00	All recordings examined	All recordings examined	All recordings examined
End time:	2013-10-01 00:00:00	2011-01-01 00:00:00			
Mean wind speed ('U_62') data:					
Readings below lower limit (0):	2184 (1.21%)	none	2184 (4.16%)	none	none
Readings above upper limit (90):	none	none	none	none	none
Calms (speeds below 0.5 m/s):	548 (0.35%)	8 (0.06%)	146 (0.29%)	74 (0.14%)	320 (0.81%)
Valid readings accepted:	155640 (86.54%)	13248 (37.55%)	50376 (95.84%)	52704 (100.0%)	39312 (100.0%)
Accepted values range:	0.00 m/s to 26.58 m/s	0.00 m/s to 25.77 m/s	0.00 m/s to 24.29 m/s	0.00 m/s to 25.43 m/s	0.00 m/s to 26.58 m/s
Mean wind direction ('D_60') data:					
Readings below lower limit (0):	40 (0.02%)	none	none	40 (0.08%)	none
Readings above upper limit (360):	none	none	none	none	none
Calms (speeds below 0.5 m/s):	548 (0.35%)	8 (0.06%)	146 (0.28%)	74 (0.14%)	320 (0.81%)
Valid readings accepted:	157784 (87.73%)	13248 (37.55%)	52560 (100.0%)	52664 (99.92%)	39312 (100.0%)
Accepted values range:	0.0° to 360.0°	1.4° to 359.2°	0.0° to 360.0°	0.0° to 360.0°	0.0° to 359.8°
Data recovery:					
Expected recording count:	157824	13248	52560	52704	39312
Count of recordings in file:	179856 (113.96%)	35280 (266.3%)	52560 (100.0%)	52704 (100.0%)	39312 (100.0%)
Recordings with invalid values in one or more fields:	2224 (1.24%)	0 (0.0%)	2184 (4.16%)	40 (0.08%)	0 (0.0%)
Entirely valid recordings accepted:	155600 (86.51%)	13248 (37.55%)	50376 (95.84%)	52664 (99.92%)	39312 (100.0%)
Recovery percentage (vs. expected):	98.59%	100.0%	95.84%	99.92%	100.0%

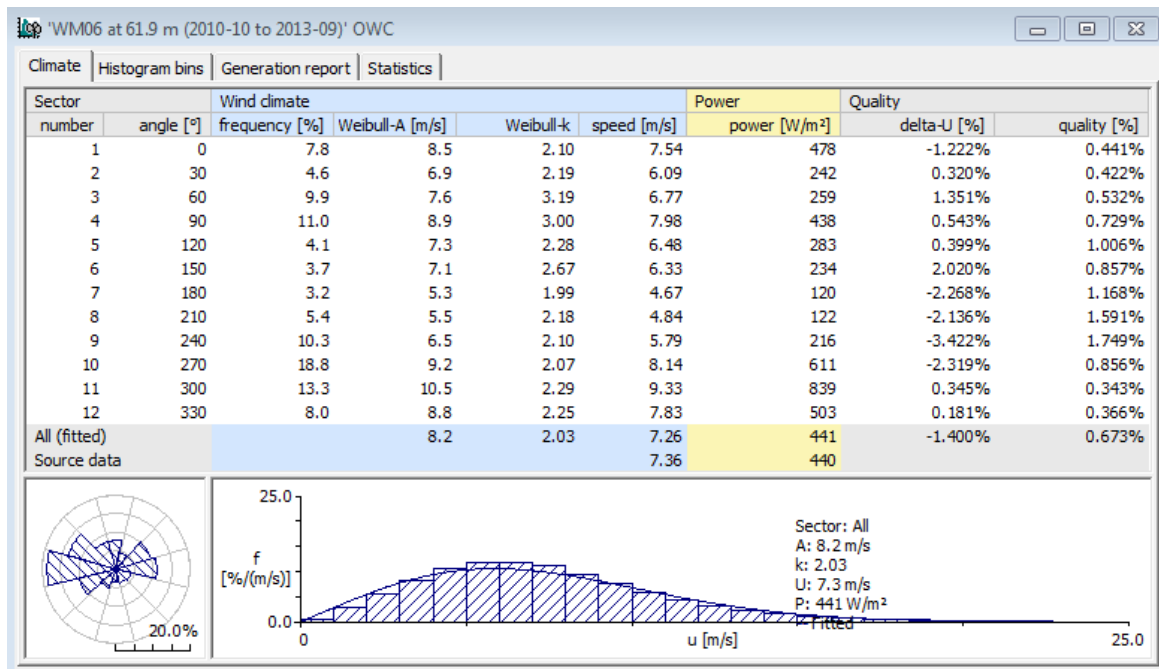

WM06 at 61.9 m (2010-10 to 2013-09) OWC

Climate | Histogram bins | Generation report | Statistics

Climate generation
 Generated at: 16/05/2014 22:51:54
 Generated using: WASP Climate Analyst (using Rvea0073) version: 2.00.0132
 Generated by: nimo on VINDRI-L17131
 Number of data sets: 4
 Source file path: D:\Countries\South Africa\WASA\Data\SA06

	All Data Summary	Data set 1	Data set 2	Data set 3	Data set 4
File information:					
Source file name:		WM06_2010.csv	WM06_2011.csv	WM06_2012.csv	WM06_2013.csv
Last modified:		2011-07-14 22:40:52	2012-08-10 12:14:13	2013-05-22 08:42:11	2013-10-11 09:46:36
Protocol:		'Protocol created for importing downloaded data' (WASA)	'Protocol created for importing downloaded data' (WASA)	'Protocol created for importing downloaded data' (WASA)	'Protocol created for importing downloaded data' (WASA)
Recordings in file:					
Count:	162144	17568	52560	52704	39312
Start time:	2010-09-01 00:10:00	2010-09-01 00:10:00	2011-01-01 00:10:00	2012-01-01 00:10:00	2013-01-01 00:10:00
End time:	2013-10-01 00:00:00	2011-01-01 00:00:00	2012-01-01 00:00:00	2013-01-01 00:00:00	2013-10-01 00:00:00
Recordings used:					
Count:	157824	13248			
Start time:	2010-10-01 00:10:00	2010-10-01 00:10:00	All recordings examined	All recordings examined	All recordings examined
End time:	2013-10-01 00:00:00	2011-01-01 00:00:00			
Mean wind speed ('U_62') data:					
Readings below lower limit (0):	165 (0.1%)	none	none	165 (0.31%)	none
Readings above upper limit (90):	none	none	none	none	none
Calms (speeds below 0.5 m/s):	142 (0.09%)	2 (0.02%)	52 (0.1%)	45 (0.09%)	43 (0.11%)
Valid readings accepted:	157659 (97.23%)	13248 (75.41%)	52560 (100.0%)	52539 (99.69%)	39312 (100.0%)
Accepted values range:	0.00 m/s to 24.75 m/s	0.00 m/s to 23.35 m/s	0.00 m/s to 24.75 m/s	0.00 m/s to 24.49 m/s	0.00 m/s to 24.16 m/s
Mean wind direction ('D_60') data:					
Readings below lower limit (0):	119 (0.07%)	none	none	119 (0.23%)	none
Readings above upper limit (360):	none	none	none	none	none
Calms (speeds below 0.5 m/s):	142 (0.09%)	2 (0.02%)	52 (0.1%)	45 (0.09%)	43 (0.11%)
Valid readings accepted:	157705 (97.26%)	13248 (75.41%)	52560 (100.0%)	52585 (99.77%)	39312 (100.0%)
Accepted values range:	0.0° to 360.0°	0.2° to 360.0°	0.0° to 360.0°	0.0° to 360.0°	0.0° to 360.0°
Data recovery:					
Expected recording count:	157824	13248	52560	52704	39312
Count of recordings in file:	162144 (102.74%)	17568 (132.61%)	52560 (100.0%)	52704 (100.0%)	39312 (100.0%)
Recordings with invalid values in one or more fields:	165 (0.1%)	0 (0.0%)	0 (0.0%)	165 (0.31%)	0 (0.0%)
Entirely valid recordings accepted:	157659 (97.23%)	13248 (75.41%)	52560 (100.0%)	52539 (99.69%)	39312 (100.0%)
Recovery percentage (vs. expected):	99.9%	100.0%	100.0%	99.69%	100.0%

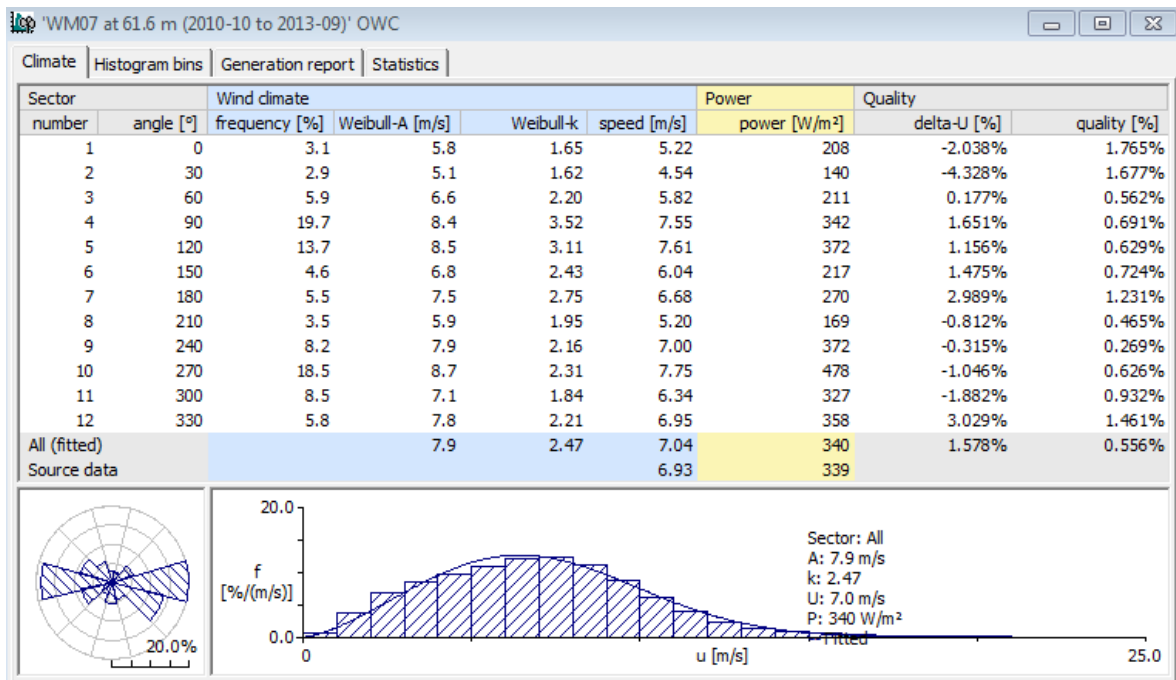

The screenshot displays the 'WM07 at 61.6 m (2010-10 to 2013-09)' OWC software interface, showing 'Climate generation' details and a summary table of data sets.

Climate generation
 Generated at: 17/05/2014
 Generated using: WASP Climate Analyst (using Rvea0073) version: 2.00.0132
 Generated by: nimo on VINDRI-L17131
 Number of data sets: 4
 Source file path: D:\Countries\South Africa\WASA\Data\SA07

	All Data Summary	Data set 1	Data set 2	Data set 3	Data set 4
File information:					
Source file name:		WM07_2010.csv	WM07_2011.csv	WM07_2012.csv	WM07_2013.csv
Last modified:		2011-07-17 17:56:10	2012-08-14 11:06:06	2013-05-22 09:10:31	2013-10-11 09:56:22
Protocol:		'Protocol created for importing downloaded data' (WASA)	'Protocol created for importing downloaded data' (WASA)	'Protocol created for importing downloaded data' (WASA)	'Protocol created for importing downloaded data' (WASA)
Recordings in file:					
Count:	179856	35280	52560	52704	39312
Start time:	2010-05-01 00:10:00	2010-05-01 00:10:00	2011-01-01 00:10:00	2012-01-01 00:10:00	2013-01-01 00:10:00
End time:	2013-10-01 00:00:00	2011-01-01 00:00:00	2012-01-01 00:00:00	2013-01-01 00:00:00	2013-10-01 00:00:00
Recordings used:					
Count:	157824	13248			
Start time:	2010-10-01 00:10:00	2010-10-01 00:10:00	All recordings examined	All recordings examined	All recordings examined
End time:	2013-10-01 00:00:00	2011-01-01 00:00:00			
Mean wind speed ('U_62') data:					
Readings below lower limit (0):	4732 (2.63%)	2 (0.01%)	1 (0.0%)	none	4729 (12.03%)
Readings above upper limit (90):	none	none	none	none	none
Calms (speeds below 0.5 m/s):	161 (0.11%)	3 (0.02%)	57 (0.11%)	66 (0.13%)	35 (0.1%)
Valid readings accepted:	153092 (85.12%)	13246 (37.55%)	52559 (100.0%)	52704 (100.0%)	34583 (87.97%)
Accepted values range:	0.00 m/s to 23.25 m/s	0.00 m/s to 19.60 m/s	0.00 m/s to 22.45 m/s	0.00 m/s to 23.14 m/s	0.00 m/s to 23.25 m/s
Mean wind direction ('D_60') data:					
Readings below lower limit (0):	3 (0.0%)	2 (0.01%)	1 (0.0%)	none	none
Readings above upper limit (360):	none	none	none	none	none
Calms (speeds below 0.5 m/s):	161 (0.1%)	3 (0.02%)	57 (0.11%)	66 (0.13%)	35 (0.09%)
Valid readings accepted:	157821 (87.75%)	13246 (37.55%)	52559 (100.0%)	52704 (100.0%)	39312 (100.0%)
Accepted values range:	0.0° to 360.0°	0.2° to 360.0°	0.0° to 360.0°	0.0° to 360.0°	0.0° to 360.0°
Data recovery:					
Expected recording count:	157824	13248	52560	52704	39312
Count of recordings in file:	179856 (113.96%)	35280 (266.3%)	52560 (100.0%)	52704 (100.0%)	39312 (100.0%)
Recordings with invalid values in one or more fields:	4732 (2.63%)	2 (0.01%)	1 (0.0%)	0 (0.0%)	4729 (12.03%)
Entirely valid recordings accepted:	153092 (85.12%)	13246 (37.55%)	52559 (100.0%)	52704 (100.0%)	34583 (87.97%)
Recovery percentage (vs. expected):	97.0%	99.98%	100.0%	100.0%	87.97%

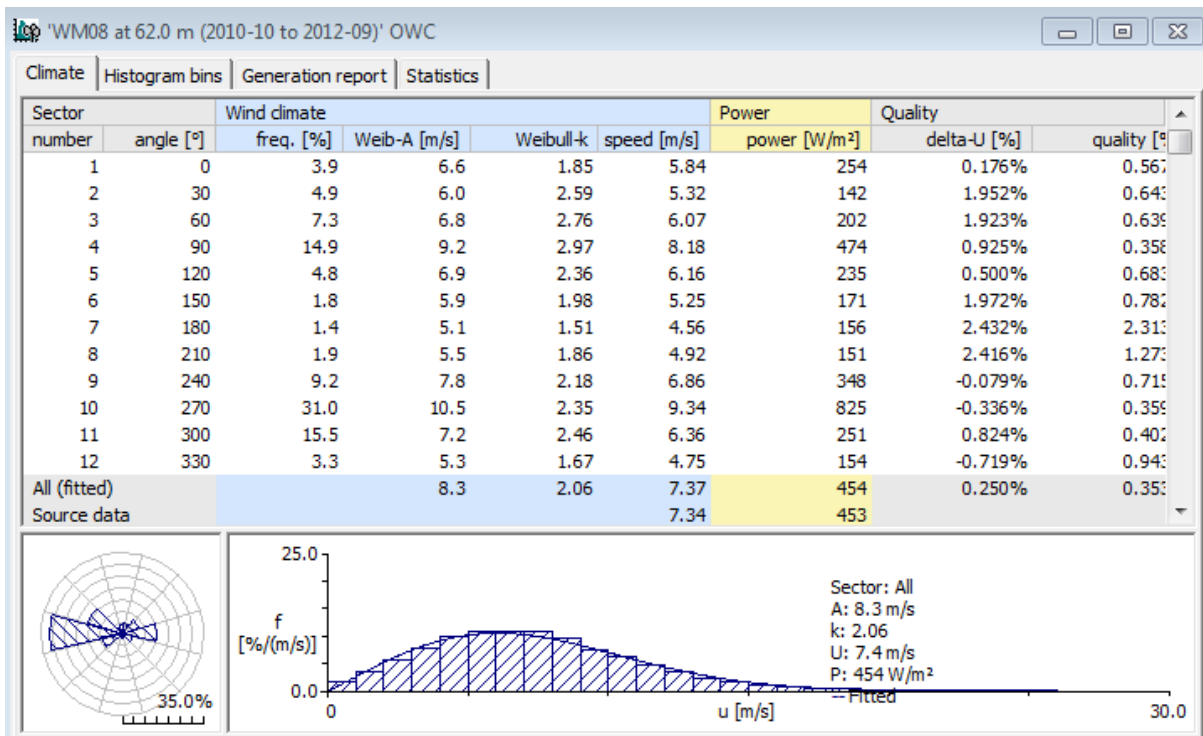

The screenshot displays the 'WM08 at 62.0 m (2010-10 to 2012-09)' OWC software interface, showing 'Climate generation' and 'All Data Summary' details.

Climate generation
 Generated at: 17/05/2014 21:27:03
 Generated using: WAsP Climate Analyst (using Rvea0073) version: 2.00.0132
 Generated by: nimo on VINDRI-L17131
 Number of data sets: 3
 Source file path: D:\Countries\South Africa\WASA\Data\SA08

	All Data Summary	Data set 1	Data set 2	Data set 3
File information:				
Source file name:	WM08_2010.csv	WM08_2011.csv	WM08_2012.csv	
Last modified:	2011-07-14 23:42:38	2012-08-14 12:38:44	2013-05-22 10:10:34	
Protocol:	'Protocol created for importing downloaded data' (WASA)	'Protocol created for importing downloaded data' (WASA)	'Protocol created for importing downloaded data' (WASA)	'Protocol created for importing downloaded data' (WASA)
Recordings in file:				
Count:	127296	22032	52560	52704
Start time:	2010-08-01 00:10:00	2010-08-01 00:10:00	2011-01-01 00:10:00	2012-01-01 00:10:00
End time:	2013-01-01 00:00:00	2011-01-01 00:00:00	2012-01-01 00:00:00	2013-01-01 00:00:00
Recordings used:				
Count:	105264	13248	All recordings examined	39456
Start time:	2010-10-01 00:10:00	2010-10-01 00:10:00		2012-01-01 00:10:00
End time:	2012-10-01 00:00:00	2011-01-01 00:00:00		2012-10-01 00:00:00
Mean wind speed ('U_62') data:				
Readings below lower limit (0):	none	none	none	none
Readings above upper limit (90):	none	none	none	none
Calms (speeds below 0.5 m/s):	874 (0.83%)	15 (0.11%)	421 (0.8%)	438 (1.11%)
Valid readings accepted:	105264 (82.69%)	13248 (60.13%)	52560 (100.0%)	39456 (74.86%)
Accepted values range:	0.00 m/s to 26.77 m/s	0.00 m/s to 20.87 m/s	0.00 m/s to 26.77 m/s	0.00 m/s to 25.02 m/s
Mean wind direction ('D_60') data:				
Readings below lower limit (0):	none	none	none	none
Readings above upper limit (360):	none	none	none	none
Calms (speeds below 0.5 m/s):	874 (0.83%)	15 (0.11%)	421 (0.8%)	438 (1.11%)
Valid readings accepted:	105264 (82.69%)	13248 (60.13%)	52560 (100.0%)	39456 (74.86%)
Accepted values range:	0.0° to 360.0°	0.2° to 360.0°	0.0° to 360.0°	0.0° to 360.0°
Data recovery:				
Expected recording count:	105264	13248	52560	39456
Count of recordings in file:	127296 (120.93%)	22032 (166.3%)	52560 (100.0%)	52704 (133.58%)
Recordings with invalid values in one or more fields:	0 (0.0%)	0 (0.0%)	0 (0.0%)	0 (0.0%)
Entirely valid recordings accepted:	105264 (82.69%)	13248 (60.13%)	52560 (100.0%)	39456 (74.86%)
Recovery percentage (vs. expected):	100.0%	100.0%	100.0%	100.0%

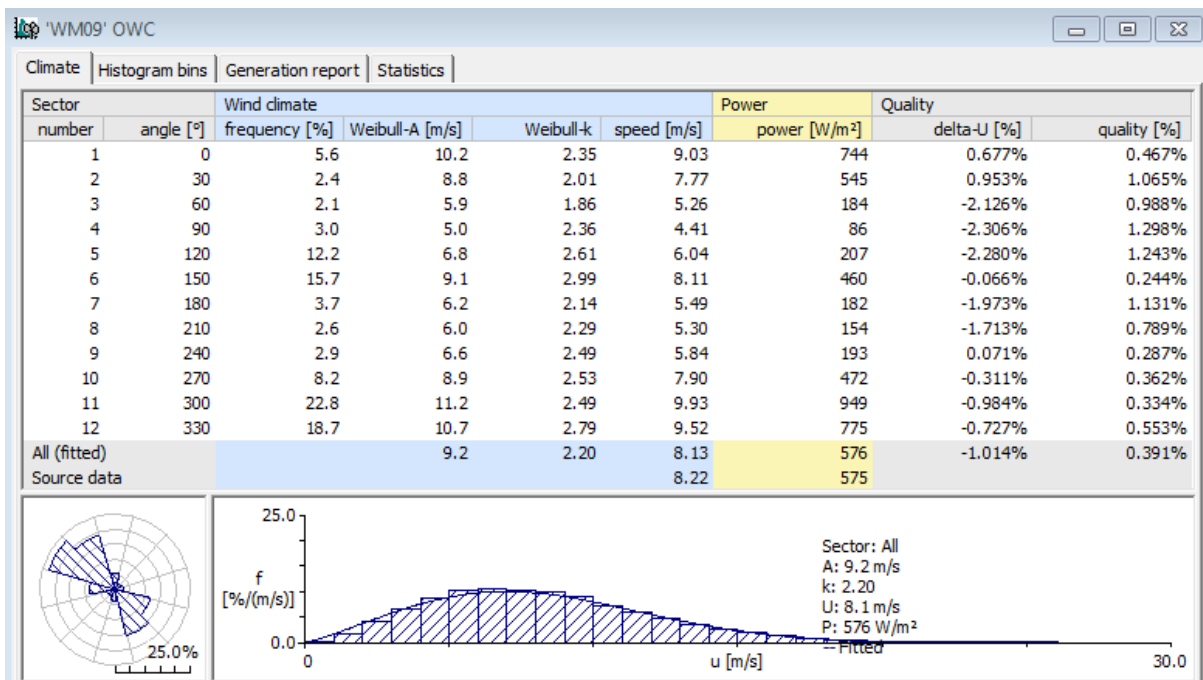

Climate generation
 Generated at: 20/05/2014 10:06:23
 Generated using: WAsP Climate Analyst (using Rvea0073) version: 2.00.0132
 Generated by: nimo on VINDRI-L17131
 Number of data sets: 3
 Source file path: D:\Countries\South Africa\WASA\Data\SA09

	All Data Summary	Data set 1	Data set 2	Data set 3
File information:				
Source file name:		WM09_2010.csv	WM09_2012.csv	WM09_2013.csv
Last modified:		2011-07-17 23:00:22	2013-05-22 11:26:40	2013-10-15 13:31:13
Protocol:		'Protocol created for importing downloaded data' (WASA)	'Protocol created for importing downloaded data' (WASA)	'Protocol created for importing downloaded data' (WASA)
Recordings in file:				
Count:	109584	17568	52704	39312
Start time:	2010-09-01 00:10:00	2010-09-01 00:10:00	2012-01-01 00:10:00	2013-01-01 00:10:00
End time:	2013-10-01 00:00:00	2011-01-01 00:00:00	2013-01-01 00:00:00	2013-10-01 00:00:00
Recordings used:				
Count:	105264	13248	All recordings examined	All recordings examined
Start time:	2010-10-01 00:10:00	2010-10-01 00:10:00		
End time:	2013-10-01 00:00:00	2011-01-01 00:00:00		
Mean wind speed ('U_62') data:				
Readings below lower limit (0):	310 (0.28%)	none	310 (0.59%)	none
Readings above upper limit (90):	none	none	none	none
Calms (speeds below 0.5 m/s):	39 (0.04%)	none	16 (0.03%)	23 (0.06%)
Valid readings accepted:	104954 (95.77%)	13248 (75.41%)	52394 (99.41%)	39312 (100.0%)
Accepted values range:	0.00 m/s to 26.66 m/s	0.62 m/s to 24.68 m/s	0.00 m/s to 25.75 m/s	0.00 m/s to 26.66 m/s
Mean wind direction ('D_60') data:				
Readings below lower limit (0):	230 (0.21%)	none	230 (0.44%)	none
Readings above upper limit (360):	none	none	none	none
Calms (speeds below 0.5 m/s):	39 (0.04%)	none	16 (0.03%)	23 (0.06%)
Valid readings accepted:	105034 (95.85%)	13248 (75.41%)	52474 (99.56%)	39312 (100.0%)
Accepted values range:	0.0° to 360.0°	0.0° to 359.9°	0.0° to 360.0°	0.0° to 360.0°
Data recovery:				
Expected recording count:	105264	13248	52704	39312
Count of recordings in file:	109584 (104.1%)	17568 (132.61%)	52704 (100.0%)	39312 (100.0%)
Recordings with invalid values in one or more fields:	331 (0.3%)	0 (0.0%)	331 (0.63%)	0 (0.0%)
Entirely valid recordings accepted:	104933 (95.76%)	13248 (75.41%)	52373 (99.37%)	39312 (100.0%)
Recovery percentage (vs. expected):	99.69%	100.0%	99.37%	100.0%

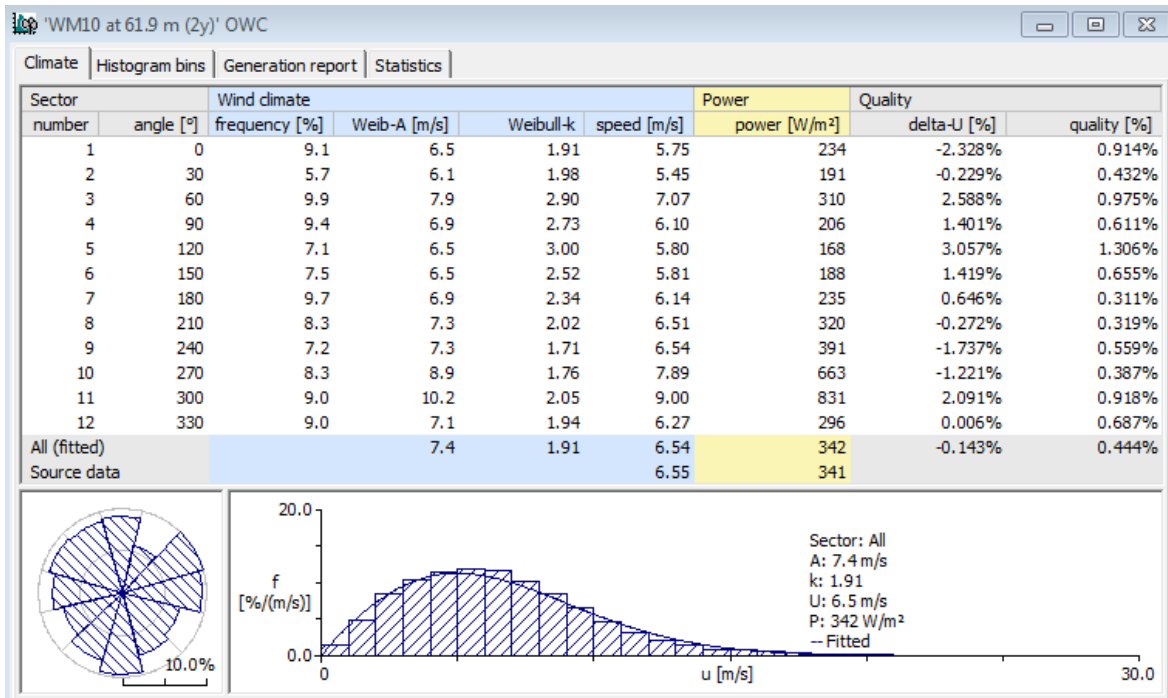

The screenshot shows the 'Climate generation' section of the software, detailing the generation date, time, and version. Below this is a summary table with columns for 'All Data Summary', 'Data set 1', 'Data set 2', 'Data set 3', and 'Data set 4'. The table includes information on file names, protocols, recordings in files, and data recovery statistics.

	All Data Summary	Data set 1	Data set 2	Data set 3	Data set 4
File information:					
Source file name:		WM10_2011.csv	WM10_2012.csv	WM10_2012.csv	WM10_2013.csv
Last modified:		2012-08-14 12:41:41	2013-05-27 10:37:19	2013-05-27 10:37:19	2013-10-15 20:42:48
Protocol:		'Protocol created for importing downloaded data' (WASA)	'Protocol created for importing downloaded data' (WASA)	'Protocol created for importing downloaded data' (WASA)	'Protocol created for importing downloaded data' (WASA)
Recordings in file:					
Count:	197280	52560	52704	52704	39312
Start time:	2011-01-01 00:10:00	2011-01-01 00:10:00	2012-01-01 00:10:00	2012-01-01 00:10:00	2013-01-01 00:10:00
End time:	2013-10-01 00:00:00	2012-01-01 00:00:00	2013-01-01 00:00:00	2013-01-01 00:00:00	2013-10-01 00:00:00
Recordings used:					
Count:	105120	44208	8352	13248	
Start time:	2011-02-28 00:10:00	2011-02-28 00:10:00	2012-01-01 00:10:00	2012-10-01 00:10:00	All recordings examined
End time:	2013-10-01 00:00:00	2012-01-01 00:00:00	2012-02-28 00:00:00	2013-01-01 00:00:00	
Mean wind speed ('U_62') data:					
Readings below lower limit (0):	1298 (0.66%)	1298 (2.47%)	none	none	none
Readings above upper limit (90):	none	none	none	none	none
Calms (speeds below 0.5 m/s):	532 (0.51%)	90 (0.21%)	20 (0.24%)	79 (0.6%)	343 (0.87%)
Valid readings accepted:	103822 (52.63%)	42910 (81.64%)	8352 (15.85%)	13248 (25.14%)	39312 (100.0%)
Accepted values range:	0.00 m/s to 28.22 m/s	0.00 m/s to 24.48 m/s	0.00 m/s to 21.75 m/s	0.00 m/s to 26.31 m/s	0.00 m/s to 28.22 m/s
Mean wind direction ('D_60') data:					
Readings below lower limit (0):	1298 (0.66%)	1298 (2.47%)	none	none	none
Readings above upper limit (360):	none	none	none	none	none
Calms (speeds below 0.5 m/s):	532 (0.51%)	90 (0.21%)	20 (0.24%)	79 (0.6%)	343 (0.87%)
Valid readings accepted:	103822 (52.63%)	42910 (81.64%)	8352 (15.85%)	13248 (25.14%)	39312 (100.0%)
Accepted values range:	0.0° to 360.0°	0.0° to 360.0°	0.0° to 360.0°	0.1° to 360.0°	0.0° to 360.0°
Data recovery:					
Expected recording count:	105120	44208	8352	13248	39312
Count of recordings in file:	197280 (187.67%)	52560 (118.89%)	52704 (631.03%)	52704 (397.83%)	39312 (100.0%)
Recordings with invalid values in one or more fields:	1298 (0.66%)	1298 (2.47%)	0 (0.0%)	0 (0.0%)	0 (0.0%)
Entirely valid recordings accepted:	103822 (52.63%)	42910 (81.64%)	8352 (15.85%)	13248 (25.14%)	39312 (100.0%)
Recovery percentage (vs. expected):	98.77%	97.06%	100.0%	100.0%	100.0%

ANNEXURE F

QA of Meteorological Data

Wind Atlas for South Africa – QA of meteorological data

Niels G. Mortensen, Wind Energy Division, Risø DTU

Meteorological data from the 10 WASA stations have been reviewed with the purpose of assuring the quality of the data, in particular for the month of August 2010. This note describes one possible procedure only; other procedures and tools may of course accomplish the same goal. This note may therefore serve as a starting for discussions on more general QA procedures for the WASA project.

1. Data handling and editing

MS Excel was used for data handling and editing; a CSV file can be exported and subsequently used as input to the WASP Climate Analyst. In order for the CSV and original TXT files to be in roughly the same format, the TXT file is read into MS Excel and:

- i. The 5 first columns are made to *Text* format
- ii. The rest of the columns are made to *Scientific* format with 4 decimals
- iii. Line 2 is made to *Numbers* format with 2 decimals

When a CSV file is subsequently exported, the format of this is then almost identical to the original TXT file, but the delimiter is comma rather than space.

2. Quality assurance procedures

2.1 MS Excel

The following data editing / quality assurance procedures are in general applied in MS Excel:

- i. Start of station data: delete all observations on the first day, until 00:00 on the following day
- ii. Start of a data file, e.g. when the station has been stopped and started again: always delete the first observation; check the next few observations as well (this item not used here).
- iii. Check units and height for each channel – change as necessary
- iv. Make monthly statistics for all channels: mean, minimum, maximum and standard deviation
- v. Check data statistics; e.g. for mean wind speed:
 - a. $0 < U_{\text{mean}} < 90$
 - b. $0 < U_{\text{min}} < 90$
 - c. $0 < U_{\text{max}} < 90$
 - d. $0 < U_{\text{sdev}} < 10$
 - e. $U_{\text{min}} < U_{\text{mean}} < U_{\text{max}}$
- vi. Missing observations and dummy values are inserted as well

After any editing, the data are saved as a CSV file.

2.2 WASP Climate Analyst

The CSV file is imported into the WASP Climate Analyst (CA); one wind instrument (62, 60, 40, 20, 10 m a.g.l.) at a time. Temperature, temperature gradient, pressure and relative humidity may also be imported, though the functionality of the CA for these parameters is not yet up-to-date. The time traces can now be displayed; below is an example from station SA 01 (August 2010 data only).

SA 01. Wind direction at 60 and 20 m (red marks correspond to observations of calm):

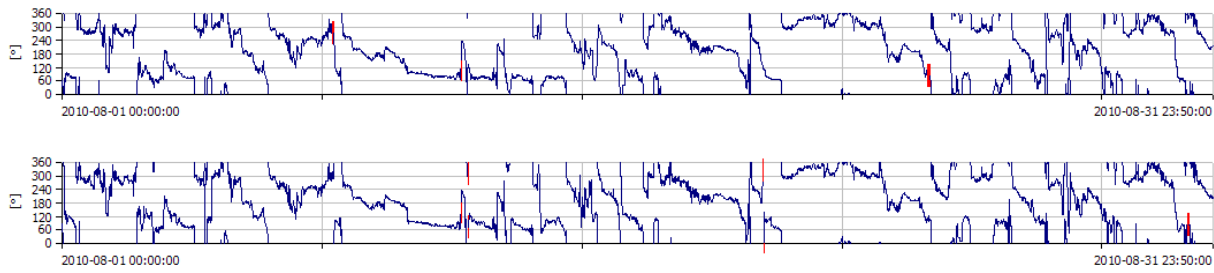

SA 01. Wind speed at 62, 60, 40, 20 and 10 m:

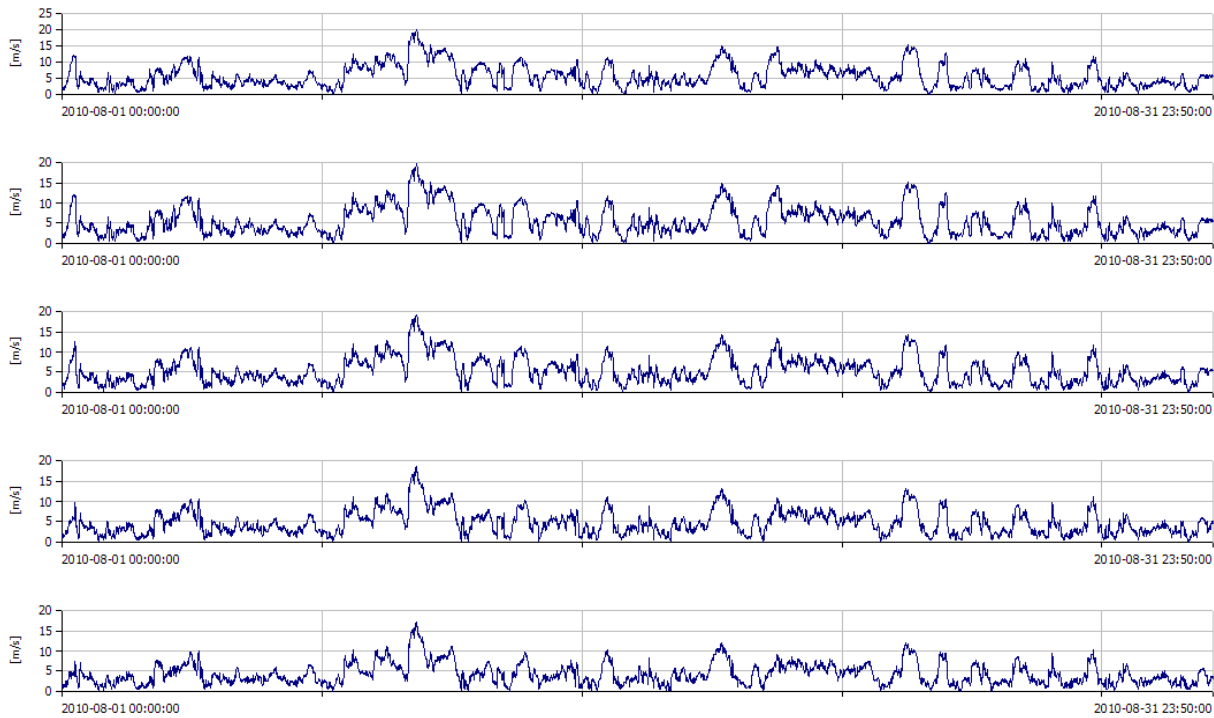

SA 01. Pressure [hPA], temperature [°C], temperature gradient [°C] and relative humidity [%]:

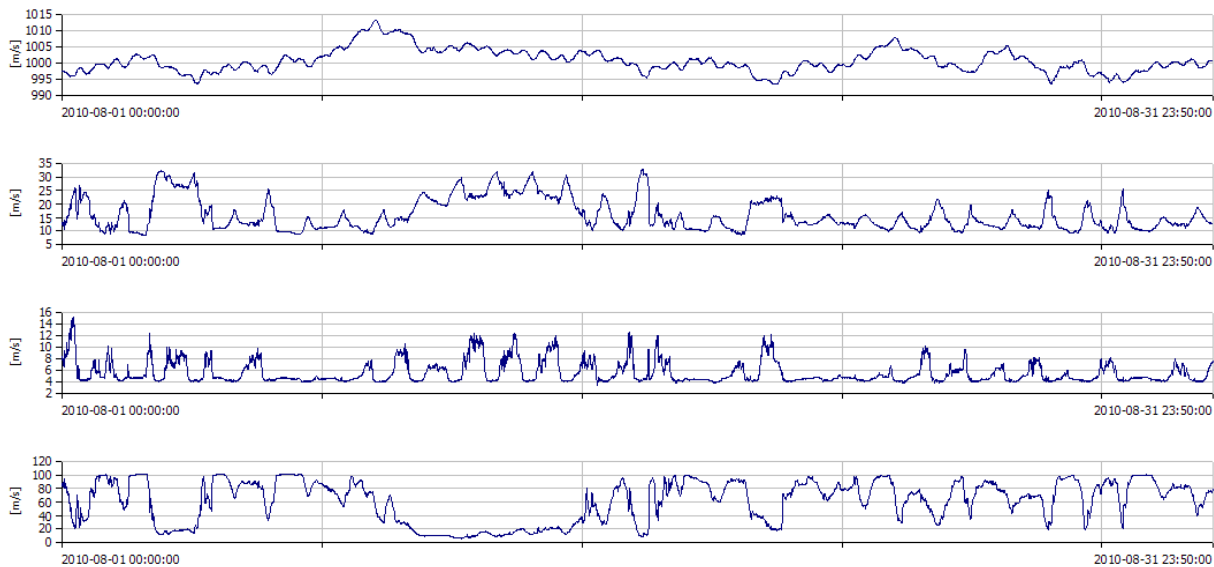

SA01. Scatter plots and wind roses for 60 and 20 m:

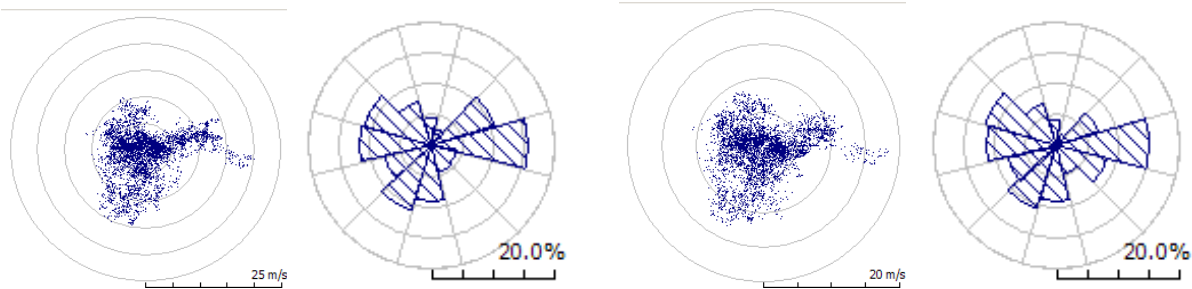

SA01. Wind speed distributions and parameters for 62, 60, 40, 20 and 10 m:

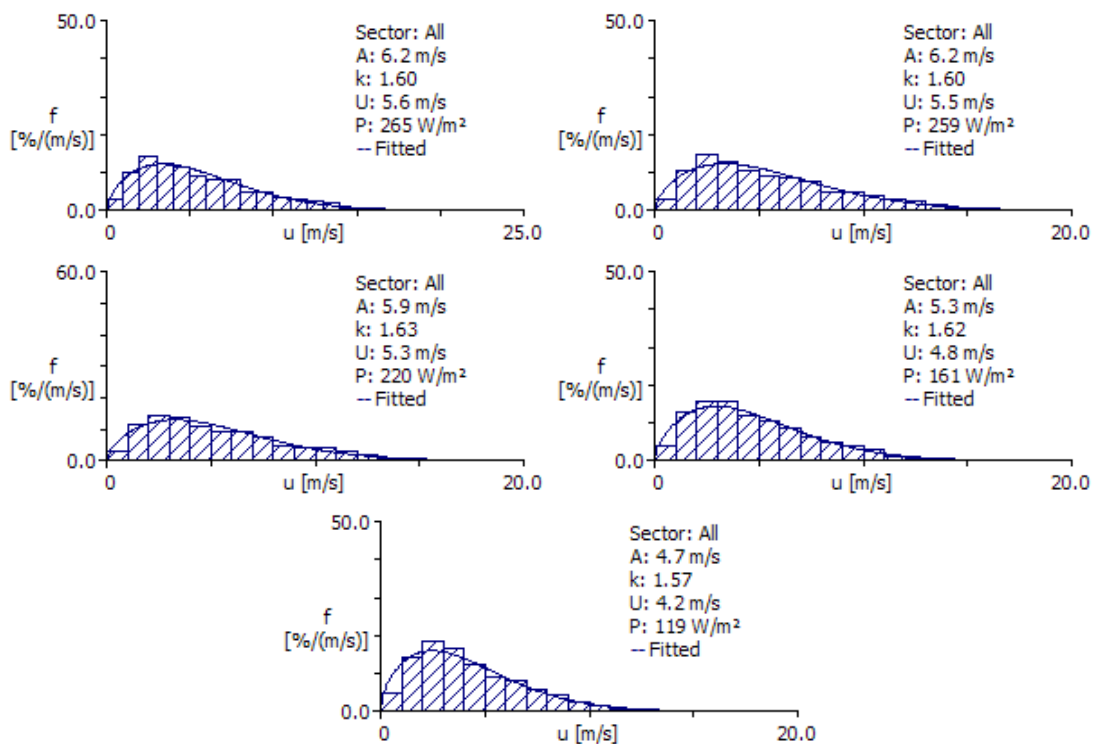

The Climate Analyst makes a few automatic checks of the time series, but the main QA is *visual inspection* of the time series and scatter plots by the user:

1. On input, the Climate Analyst checks the time stamps and observation intervals
2. On input, the Climate Analyst checks for missing records in the data series
 - Missing observations are inserted in the XSLX file with dummy values
3. Are there any spikes or sudden drops in the data series?
4. Are there periods of constant data values in the data series?
5. Are there periods of missing data in the data series?
6. Are there any unusual (regular) patterns in the data series?
7. Are there any unusual patterns in the wind rose scatter plot?
8. Do the wind speed time traces follow each other at the 5 levels?
9. Do the wind direction time traces follow each other at the 2 levels?
10. Do the wind direction distributions look similar, only slightly turned?

11. Do measured and Weibull-derived values of U and P compare well?

12. Does the calm class ($0-1 \text{ ms}^{-1}$) in the histogram look realistic?

Items 11 and 12 are checked in the Observed Mean Wind Climate window of the Climate Analyst:

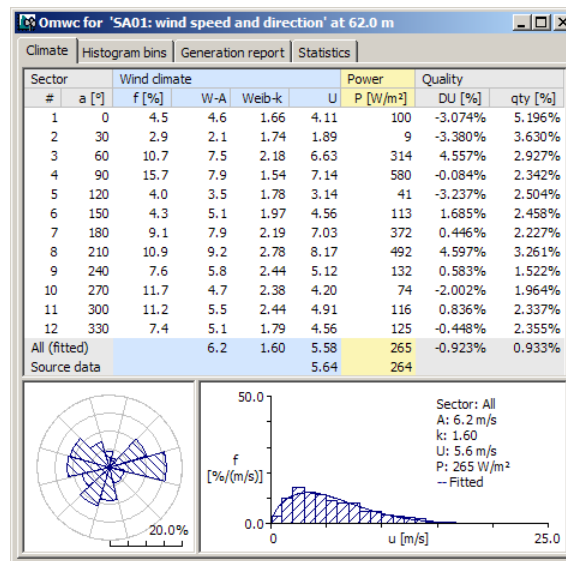

Finally, the observed wind climates are calculated and exported to OWC files. The OWC file can be inserted into WASP, as a child of a meteorological station member in the WASP hierarchy.

The RODEO system should also be used for visual inspection of the time-series data, in particular those data that are not imported into the Climate Analyst. In addition, some calculated channels and plots can be made in RODEO to further explore the data quality.

3. Specific comments for each station

4.

The comments given below may refer to the entire data series or the data file for August 2010 only. Two versions of the data have been processed; as reflected by the comments below. Some general observations pertaining to most stations are:

- Some units and heights were not correct in the header of some files
 - Fixed in database and updated version of the data
- Some wind directions were larger than 360
 - Fixed in database and updated version of the data
- Some relative humidities were larger than 100
 - Fixed in database and updated version of the data
- Dummy values inserted in CSV files are '-9999.999'
- First month for download is August 2010

In addition to these general observations, the following has been noted for each station:

Mast SA01

- Nothing additional to report

Mast SA02

- Nothing additional to report

Mast SA03

1. Four missing observations inserted at 2010,07,02,13,20-50 (-9999.999)
2. Two missing observations inserted at 2010,07,02,15,40-50 (-9999.999)
3. Two missing observations inserted at 2010,09,08,16, 50-00 (-9999.999)
4. One missing observations inserted at 2010,09,09,12, 50 (-9999.999)

Mast SA04

1. One missing observation inserted at 2010,06,04,08,50 (-9999.999)
2. Two missing observations inserted at 2010,06,04,11,50-12,00 (-9999.999)

Mast SA05

1. Erroneous wind speed U_{60} values from start and up until 2010,05,24,12,50 (-9999.999)
2. Erroneous temperature values from start and up until 2010,05,24,12,50 (-9999.999)
3. Erroneous relative humidity value at 2010,05,24,12,40 (-9999.999)

Mast SA06

1. No data available / processed from Mast SA06

Mast SA07

1. One missing observation inserted at 2010,06,04,14,20 (-9999.999)

Mast SA08

1. 510 missing observations inserted from 2010,08,01,00,00 to 2010,08,04,12,50 (-9999.999)

Mast SA09

1. 4464 missing observations inserted from 2010,08,01,00,00 to 2010,08,31,23,50 (-9999.999)
2. 87 missing observations inserted from 2010,09,01,00,00 to 2010,09,01,14,20 (-9999.999)
3. One missing observation inserted at 2010,09,08,07,50 (-9999.999)
4. One missing observation inserted at 2010,09,14,09,10 (-9999.999)

Mast SA10

1. 660 missing observations inserted from 2010,08,01,00,00 to 2010,08,05,13,50 (-9999.999)

Conclusions and recommendations

Data from 10 masts in the WASA project have been screened in order to assess the quality of the data. Very few problems have been identified so far and the data recovery rates are very high. Most irregularities are associated with the fact that this is the first screening of the data, and many of these small problems can be solved at once – and for good. The reasons for the occurrence of some missing or erroneous observations at some stations are not known.

For completeness, the following general recommendations are also made:

- Original data files should be saved, backed up and never changed
- All changes and corrections should be done on copies of the original data files
- Each station should have a log-book where all changes to the station instrumentation and set-up – as well as any other significant events in the station history – are recorded.

- Time-series data files made available to parties outside of the WASA project should be complete; i.e. contain data or dummy data for all available time steps.

An extremely important part of the final QA is an (independent) inspection of the site and met. station; this site inspection mission will further provide information that is necessary for reliable microscale modelling of the stations.

Appendix A. Data file format (preliminary TXT files)

The data files analysed were supplied in ASCII text format and contained the following parameters:

Channel #	Parameter	Format (Excel)	Units	Height	Range	Notes
1	YYYY	Text	n/a	n/a	n/a	
2	MM	Text	n/a	n/a	n/a	
3	DD	Text	n/a	n/a	n/a	
4	hh	Text	n/a	n/a	n/a	
5	mm	Text	n/a	n/a	n/a	
6	WS_62_mean	Scientific, 5	m/s	62.00	0 - 90	Calm threshold = 0.3
7	WS_62_min	Scientific, 5	m/s	62.00		
8	WS_62_max	Scientific, 5	m/s	62.00		
9	WS_62_stdev	Scientific, 5	m/s	62.00		
10	WS_60_mean	Scientific, 5	m/s	60.00	0 - 90	Calm threshold = 0.3
11	WS_60_min	Scientific, 5	m/s	60.00		
12	WS_60_max	Scientific, 5	m/s	60.00		
13	WS_60_stdev	Scientific, 5	m/s	60.00		
14	WS_40_mean	Scientific, 5	m/s	40.00	0 - 90	Calm threshold = 0.3
15	WS_40_min	Scientific, 5	m/s	40.00		
16	WS_40_max	Scientific, 5	m/s	40.00		
17	WS_40_stdev	Scientific, 5	m/s	40.00		
18	WS_20_mean	Scientific, 5	m/s	20.00	0 - 90	Calm threshold = 0.3
19	WS_20_min	Scientific, 5	m/s	20.00		
20	WS_20_max	Scientific, 5	m/s	20.00		
21	WS_20_stdev	Scientific, 5	m/s	20.00		
22	WS_10_mean	Scientific, 5	m/s	10.00	0 - 90	Calm threshold = 0.3
23	WS_10_min	Scientific, 5	m/s	10.00		
24	WS_10_max	Scientific, 5	m/s	10.00		
25	WS_10_stdev	Scientific, 5	m/s	10.00		
26	WD_60_mean	Scientific, 5	°	60.00	0 - 360	Calm threshold = 0.3
27	WD_60_min	Scientific, 5	°	60.00		
28	WD_60_max	Scientific, 5	°	60.00		

29	WD_60_stdev	Scientific, 5	°	60.00		
30	WD_20_mean	Scientific, 5	°	20.00	0 - 360	Calm threshold = 0.3
31	WD_20_min	Scientific, 5	°	20.00		
32	WD_20_max	Scientific, 5	°	20.00		
33	WD_20_stdev	Scientific, 5	°	20.00		
34	Tair_mean	Scientific, 5	°C	60.00		
35	Tair_min	Scientific, 5	°C	60.00		
36	Tair_max	Scientific, 5	°C	60.00		
37	Tair_stdev	Scientific, 5	°C	60.00		
38	Tgrad_mean	Scientific, 5	°C	60.00		
39	Tgrad_min	Scientific, 5	°C	60.00		
40	Tgrad_max	Scientific, 5	°C	60.00		
41	Tgrad_stdev	Scientific, 5	°C	60.00		
42	Pbaro_mean	Scientific, 5	hPa	6.00		
43	Pbaro_min	Scientific, 5	hPa	6.00		
44	Pbaro_max	Scientific, 5	hPa	6.00		
45	Pbaro_stdev	Scientific, 5	hPa	6.00		
46	RH_mean	Scientific, 5	%	60.00	0 - 100	
47	RH_min	Scientific, 5	%	60.00		
48	RH_max	Scientific, 5	%	60.00		
49	RH_stdev	Scientific, 5	%	60.00		
50	Vbat_mean	Scientific, 5	V	6.00		
51	Vbat_min	Scientific, 5	V	6.00		
52	Vbat_max	Scientific, 5	V	6.00		
53	Vbat_stdev	Scientific, 5	V	6.00		

Wind Atlas for South Africa – QA of meteorological data October 2010

Niels G. Mortensen, Wind Energy Division, Risø DTU

Meteorological data for October 2010 from the 10 WASA stations have been screened with the purpose of assuring the quality of the data. Data were received in ANSI text format since some text editors do not treat Unicode files correctly. Missing observations and erroneous values are flagged with dummy values (-9999.999); in the final download files such values will be flagged as 'null'. New WASP Climate Analyst projects with monthly data files have been uploaded to the WASA team site.

Mast SA01

1. Nothing to report

Mast SA02

1. Nothing to report

Mast SA03

1. Nothing to report

Mast SA04

1. Nothing to report

Mast SA05

1. 8 missing observations inserted from 2010,10,07,14,40 to 2010,10,07,15,50
2. 5 erroneous wind speed U_{40} observations (all 4 columns) from 2010,10,07,13,00 to 2010,10,07,13,40

Mast SA06

1. Nothing to report

Mast SA07

1. Nothing to report

Mast SA08

1. Nothing to report

Mast SA09

1. Nothing to report

Mast SA10

1. Nothing to report

Wind Atlas for South Africa – QA of meteorological data November 2010

Niels G. Mortensen, Wind Energy Division, Risø DTU

Meteorological data for November 2010 from the 10 WASA stations have been screened with the purpose of assuring the quality of the data. The screening comprises mean wind speed and direction from 5 levels, as well as mean temperature, temperature difference, pressure and relative humidity; visual inspection of all parameters at the WASA Rodeo site is not included. Missing observations and erroneous values are flagged with dummy values (-9999.999); in the final download files such values will be flagged as 'null'. Updated WASP Climate Analyst projects with monthly data files have been uploaded to the WASA team site.

Mast SA01

1. Nothing to report

Mast SA02

1. Nothing to report

Mast SA03

1. Nothing to report

Mast SA04

1. Nothing to report

Mast SA05

1. Measuring heights are still wrong in the header of the SA05 files.

Mast SA06

1. Nothing to report

Mast SA07

1. Nothing to report

Mast SA08

1. Nothing to report

Mast SA09

1. Nothing to report

Mast SA10

1. Nothing to report

Wind Atlas for South Africa – QA of meteorological data December 2010

Niels G. Mortensen, Wind Energy Division, Risø DTU

Meteorological data for December 2010 from the 10 WASA stations have been screened with the purpose of assuring the quality of the data. The screening comprises mean wind speed and direction from 5 levels, as well as mean temperature, temperature difference, pressure and relative humidity; visual inspection of all parameters at the WASA Rodeo site is not included in the present screening. Missing observations and erroneous values are flagged with dummy values (-9999.999); in the final download files such values will be flagged as 'null'. Updated WASP Climate Analyst projects with monthly data files have been uploaded to the WASA team site. Note, that magnetic declination values have been added with the opposite sign from this month, so all previous wind direction data in the Climate Analyst projects on the team site are off by two declination values. This will be corrected in February of 2011.

Mast SA01

1. Nothing to report

Mast SA02

1. Nothing to report

Mast SA03

1. Nothing to report

Mast SA04

1. Nothing to report

Mast SA05

1. Measuring heights are still wrong in the header of the SA05 files.

Mast SA06

1. Nothing to report

Mast SA07

1. One missing observation inserted at 2010,12,14,13,20 (-9999.999)
2. One missing observation inserted at 2010,12,14,13,40 (-9999.999)

Mast SA08

1. Nothing to report

Mast SA09

1. Nothing to report

Mast SA10

1. Three missing observations inserted from 2010,12,14,12,50 to 2010,12,14,13,10 (-9999.999)
2. 290 missing observations inserted from 2010,12,29,23,40 to 2010,12,31,23,50 (-9999.999)

Wind Atlas for South Africa – QA of meteorological data January 2011

Niels G. Mortensen, Wind Energy Division, Risø DTU

Meteorological data for January 2011 from the 10 WASA stations have been screened with the purpose of assuring the quality of the data. The screening comprises mean wind speed and direction from 5 levels, as well as mean temperature, temperature difference, pressure and relative humidity; visual inspection of all parameters at the WASA Rodeo site is not included in the present screening. Missing observations and erroneous values are flagged with dummy values (-9999.999); in the final download files such values will be flagged as 'null'. Updated WASP Climate Analyst projects with monthly data files have been uploaded to the WASA team site. Note, that magnetic declination values have been added with the opposite sign from December 2010, so all previous wind direction data in the Climate Analyst projects on the team site are still off by two declination values.

Mast SA01

1. Nothing to report

Mast SA02

1. Nothing to report

Mast SA03

1. Nothing to report

Mast SA04

1. Nothing to report

Mast SA05

1. Measuring heights are still wrong in the header of the SA05 files.

Mast SA06

1. 11 erroneous ΔT observations (all 4 columns) from 2011,01,07,16,30 to 2011,01,07,18,10

Mast SA07

1. Nothing to report

Mast SA08

1. Nothing to report

Mast SA09

1. Nothing to report

Mast SA10

1. 2384 missing observations inserted from 2011,01,01,00,00 to 2011,01,17,13,10 (-9999.999)

Wind Atlas for South Africa – QA of meteorological data February 2011

Niels G. Mortensen, Wind Energy Division, Risø DTU

Meteorological data for February 2011 from the 10 WASA stations have been screened with the purpose of assuring the quality of the data. The screening comprises mean wind speed and direction from 5 levels, as well as mean temperature, temperature difference, pressure and relative humidity; visual inspection of all parameters at the WASA Rodeo site is not included in the present screening. Missing observations and erroneous values are flagged with dummy values (-9999.999); in the final download files such values will be flagged as 'null'. Updated WASP Climate Analyst projects with monthly data files have been uploaded to the WASA team site as "WMxx.wcp" files, where xx is the number of the station.

Some irregularities in the reporting of the panel temperature are reported in the accompanying mail.

Mast SA01

1. Nothing to report

Mast SA02

1. Nothing to report

Mast SA03

1. Nothing to report

Mast SA04

1. Nothing to report

Mast SA05

1. Nothing to report

Mast SA06

1. Nothing to report

Mast SA07

1. Nothing to report

Mast SA08

1. Nothing to report

Mast SA09

1. Nothing to report

Mast SA10

1. Nothing to report

Wind Atlas for South Africa – QA of meteorological data March 2011

Niels G. Mortensen, Wind Energy Division, Risø DTU

Meteorological data for March 2011 from the 10 WASA stations have been screened with the purpose of assuring the quality of the data. The screening comprises mean wind speed and direction from 5 levels, as well as mean temperature, temperature difference, pressure and relative humidity; visual inspection of all parameters at the WASA Rodeo site is not included in the present screening. Missing observations and erroneous values are flagged with dummy values (-9999.999); in the final download files such values will be flagged as 'null'. Updated WASP Climate Analyst projects with monthly data files have been uploaded to the WASA team site as "WMxx.wcp" files, where xx is the number of the station.

Mast SA01

1. Nothing to report

Mast SA02

1. Nothing to report

Mast SA03

1. Nothing to report

Mast SA04

1. Nothing to report

Mast SA05

1. Nothing to report

Mast SA06

1. Nothing to report

Mast SA07

1. Nothing to report

Mast SA08

1. Nothing to report

Mast SA09

1. Nothing to report

Mast SA10 (updated)

1. All channels should be NULL'ed from 201103081230 to 201103170910
2. U_{40} (all 4 channels) should be NULL'ed from 201103050130 to 201103170910
3. U_{20} (all 4 channels) should be NULL'ed from 201103042230 to 201103172020
4. U_{20} (all 4 channels) should be NULL'ed from 201103181020 to 201103201250
5. U_{10} (all 4 channels) should be NULL'ed from 201103042230 to 201103170910
6. T_{mean} (all 4 channels) should be NULL'ed from 201103211200 to 201103211300

Wind Atlas for South Africa – QA of meteorological data April 2011

Niels G. Mortensen, Wind Energy Division, Risø DTU

Meteorological data for April 2011 from the 10 WASA stations have been screened with the purpose of assuring the quality of the data. The screening comprises mean wind speed and direction from 5 levels, as well as mean temperature, temperature difference, pressure and relative humidity; visual inspection of all parameters at the WASA Rodeo site is not included in the present screening. Missing observations and erroneous values are flagged with dummy values (-9999.999); in the final download files such values will be flagged as 'null'. Updated WASP Climate Analyst projects with monthly data files have been uploaded to the WASA team site as "WMxx.wcp" files, where xx is the number of the station.

Mast SA01

1. Nothing to report

Mast SA02

1. Nothing to report

Mast SA03

1. Nothing to report

Mast SA04

1. Nothing to report

Mast SA05

1. Nothing to report

Mast SA06

1. Nothing to report

Mast SA07

1. Nothing to report

Mast SA08

1. Nothing to report

Mast SA09

1. Nothing to report

Mast SA10 (updated)

1. Nothing to report

Wind Atlas for South Africa – QA of meteorological data May 2011

Niels G. Mortensen, Wind Energy Division, Risø DTU

Meteorological data for May 2011 from the 10 WASA stations have been screened with the purpose of assuring the quality of the data. The screening comprises mean wind speed and direction from 5 levels, as well as mean temperature, temperature difference, pressure and relative humidity; visual inspection of all parameters at the WASA Rodeo site is not included in the present screening. Missing observations and erroneous values are flagged with dummy values (-9999.999); in the final download files such values will be flagged as 'null'. Updated WASP Climate Analyst projects with monthly data files have been uploaded to the WASA team site as "WMxx.wcp" files, where xx is the number of the station.

Mast SA01

1. Nothing to report

Mast SA02

1. Nothing to report

Mast SA03

1. Nothing to report

Mast SA04

1. Nothing to report

Mast SA05

1. Nothing to report

Mast SA06

1. Nothing to report

Mast SA07

1. Nothing to report

Mast SA08

1. Nothing to report

Mast SA09

1. Nothing to report

Mast SA10 (updated)

1. Nothing to report

Wind Atlas for South Africa – QA of meteorological data June 2011

Niels G. Mortensen, Wind Energy Division, Risø DTU

Meteorological data for June 2011 from the 10 WASA stations have been screened with the purpose of assuring the quality of the data. The screening comprises mean wind speed and direction from 5 levels, as well as mean temperature, temperature difference, pressure and relative humidity; visual inspection of all parameters at the WASA Rodeo site is not included in the present screening. Missing observations and erroneous values are flagged with dummy values (-9999.999); in the final download files such values will be flagged as 'NULL'. Updated WASP Climate Analyst projects with monthly data files have been uploaded to the WASA team site as "WMxx.wcp" files, where xx is the number of the station.

Mast SA01

1. Nothing to report

Mast SA02

1. Nothing to report

Mast SA03

1. Nothing to report

Mast SA04

1. Nothing to report

Mast SA05

1. 2184 erroneous wind speed U_{62} observations (all 4 columns) from 2011,06,13,09,00 to 2011,06,28,12,50

Mast SA06

1. Nothing to report

Mast SA07

1. Nothing to report

Mast SA08

1. Nothing to report

Mast SA09

1. Nothing to report

Mast SA10 (updated)

1. 7 erroneous observations (all columns) from 2011-06-21 13:40:00 to 2011-06-21 14:40:00
2. 3 erroneous observations (all columns) from 2011-06-27 13:10:00 to 2011-06-27 13:30:00
3. 2 erroneous observations (all columns) from 2011-06-27 13:50:00 to 2011-06-27 14:00:00
4. 1 erroneous observation (all columns) at 2011-06-28 18:10:00
5. 7 erroneous observations (all columns) from 2011-06-29 15:30:00 to 2011-06-29 16:30:00

Wind Atlas for South Africa – QA of meteorological data July 2011

Niels G. Mortensen, Wind Energy Division, Risø DTU

Meteorological data for July 2011 from the 10 WASA stations have been screened with the purpose of assuring the quality of the data. The screening comprises mean wind speed and direction from 5 levels, as well as mean temperature, temperature difference, pressure and relative humidity; visual inspection of all parameters at the WASA Rodeo site is not included in the present screening. Missing observations and erroneous values are flagged with dummy values (-9999.999); in the final download files such values will be flagged as 'NULL'. Updated WASP Climate Analyst projects with monthly data files have been uploaded to the WASA team site as "WMxx.wcp" files, where xx is the number of the station.

Mast SA01

1. Nothing to report

Mast SA02

1. Nothing to report

Mast SA03

1. Nothing to report

Mast SA04

1. Nothing to report

Mast SA05

1. Nothing to report

Mast SA06

1. Nothing to report

Mast SA07

1. Nothing to report

Mast SA08

1. Nothing to report

Mast SA09

All channels were 'nulled' from 2011 0726 0950 to end of file, why? Is data logger frozen/broken?

1. U_{62} (4 channels) frozen from 2011 0725 0700 to end of file
2. U_{60} (4 channels) frozen from 2011 0725 0300 to end of file
3. U_{40} (4 channels) frozen from 2011 0725 0720 to end of file
4. U_{20} (4 channels) frozen from 2011 0725 0830 to end of file
5. U_{10} (4 channels) frozen from 2011 0725 1240 to end of file
6. D_{60} (4 channels) frozen from 2011 0725 0300 to end of file
7. D_{20} (4 channels) frozen from 2011 0725 0300 to end of file
8. Rh (4 channels) frozen from 2011 0725 0300 to end of file

Mast SA10

1. Nothing to report, but channel allocation must be checked!

Wind Atlas for South Africa – QA of meteorological data August 2011

Niels G. Mortensen, Wind Energy Division, Risø DTU

Meteorological data for August 2011 from the 10 WASA stations have been screened with the purpose of assuring the quality of the data. The screening comprises mean wind speed and direction from 5 levels, as well as mean temperature, temperature difference, pressure and relative humidity; visual inspection of all parameters at the WASA Rodeo site is not included in the present screening. Missing observations and erroneous values are flagged with dummy values (-9999.999); in the final download files such values will be flagged as 'NULL'. Updated WASP Climate Analyst projects with monthly data files have been uploaded to the WASA team site as "WMxx.wcp" files, where xx is the number of the station.

Mast SA01

1. Nothing to report

Mast SA02

1. Nothing to report

Mast SA03

1. Nothing to report

Mast SA04

1. Nothing to report

Mast SA05

1. Nothing to report

Mast SA06

1. Nothing to report

Mast SA07

1. Nothing to report

Mast SA08

1. Nothing to report

Mast SA09

1. All channels should be 'NULL' (station not in operation)

Mast SA10

1. Nothing to report, but channel allocation must be checked!

All masts

1. Nothing to report

Wind Atlas for South Africa – QA of meteorological data September 2011

Niels G. Mortensen, Wind Energy Division, Risø DTU

Meteorological data for September 2011 from the 10 WASA stations have been screened with the purpose of assuring the quality of the data. The screening comprises mean wind speed and direction from 5 levels, as well as mean temperature, temperature difference, pressure and relative humidity; visual inspection of all parameters at the WASA Rodeo site is not included in the present screening. Missing observations and erroneous values are flagged with dummy values (-9999.999); in the final download files such values will be flagged as 'NULL'. Updated WASP Climate Analyst projects with monthly data files have been uploaded to the WASA team site as "WMxx.wcp" files, where xx is the number of the station.

Mast SA01

1. Nothing to report

Mast SA02

1. Nothing to report

Mast SA03

1. Nothing to report

Mast SA04

1. Nothing to report

Mast SA05

1. Nothing to report

Mast SA06

1. Nothing to report

Mast SA07

1. Nothing to report

Mast SA08

1. Nothing to report

Mast SA09

1. All channels should be 'NULL' (station not in operation)

Mast SA10

1. Nothing to report (but channel allocation must be checked)

All masts – January through August 2011 (downloaded data from WASA site)

1. Negative wind directions in WM05 data for June and July 2011

Wind Atlas for South Africa – QA of meteorological data October 2011

Niels G. Mortensen, Wind Energy Division, Risø DTU

Meteorological data for October 2011 from the 10 WASA stations have been screened with the purpose of assuring the quality of the data. The screening comprises mean wind speed and direction from 5 levels, as well as mean temperature, temperature difference, pressure and relative humidity; visual inspection of all parameters at the WASA Rodeo site is not included in the present screening. Missing observations and erroneous values are flagged with dummy values (-9999.999); in the final download files such values will be flagged as 'NULL'. Updated WASP Climate Analyst projects with monthly data files have been uploaded to the WASA team site as "WMxx.wcp" files, where xx is the number of the station.

Mast SA01

1. Nothing to report

Mast SA02

1. Nothing to report

Mast SA03

1. Nothing to report

Mast SA04

1. Nothing to report

Mast SA05

1. Nothing to report

Mast SA06

1. Nothing to report

Mast SA07

1. Nothing to report

Mast SA08

1. Nothing to report

Mast SA09

1. All channels should be 'NULL' (station not in operation)

Mast SA10

1. Nothing to report (but channel allocation must be checked)

All masts – September 2011 (downloaded data from WASA site)

1. Nothing to report

Wind Atlas for South Africa – QA of meteorological data November 2011

Niels G. Mortensen, Wind Energy Division, Risø DTU

Meteorological data for November 2011 from the 10 WASA stations have been screened with the purpose of assuring the quality of the data. The screening comprises mean wind speed and direction from 5 levels, as well as mean temperature, temperature difference, pressure and relative humidity; visual inspection of all parameters at the WASA Rodeo site is not included in the present screening. Missing observations and erroneous values are flagged with dummy values (-9999.999); in the final download files such values will be flagged as 'NULL'. Updated WASP Climate Analyst projects with monthly data files have been uploaded to the WASA team site as "WMxx.wcp" files, where xx is the number of the station.

Mast SA01

1. Nothing to report

Mast SA02

1. Nothing to report

Mast SA03

1. Nothing to report

Mast SA04

1. Nothing to report

Mast SA05

1. Nothing to report

Mast SA06

1. Nothing to report

Mast SA07

1. Nothing to report

Mast SA08

1. Nothing to report

Mast SA09

1. All channels should be 'NULL' (station not in operation)

Mast SA10

1. Nothing to report

NIMO: Channel allocation should be checked when we meet in December 2011.

Wind Atlas for South Africa – QA of meteorological data December 2011

Niels G. Mortensen, Wind Energy Department, DTU Risø Campus

Meteorological data for December 2011 from the 10 WASA stations have been screened with the purpose of assuring the quality of the data. The screening comprises mean wind speed and direction from 5 levels, as well as mean temperature, temperature difference, pressure and relative humidity; visual inspection of all parameters at the WASA Rodeo site is not included in the present screening. Missing observations and erroneous values are flagged with dummy values (-9999.999); in the final download files such values will be flagged as 'NULL'. Updated WASP Climate Analyst projects with monthly data files have been uploaded to the WASA team site as "WMxx.wcp" files, where xx is the number of the station.

Mast SA01

1. Nothing to report

Mast SA02

1. Nothing to report

Mast SA03

1. Nothing to report

Mast SA04

1. Nothing to report

Mast SA05

1. Nothing to report

Mast SA06

1. Nothing to report

Mast SA07

1. Nothing to report

Mast SA08

1. Nothing to report

Mast SA09

1. 3099 missing observations from 2011-12-01 00:10:00 to 2011-12-22 12:30:00 (marked already w/ NULL)

Mast SA10

1. Nothing to report

Wind Atlas for South Africa – QA of meteorological data January 2012

Niels G. Mortensen, Wind Energy Department, DTU Risø Campus

Meteorological data for January 2012 from the 10 WASA stations have been screened with the purpose of assuring the quality of the data. The screening comprises mean wind speed and direction from 5 levels, as well as mean temperature, temperature difference, pressure and relative humidity; visual inspection of all parameters at the WASA Rodeo site is not included in the present screening. Missing observations and erroneous values are flagged with dummy values (-9999.999); in the final download files such values will be flagged as 'NULL'. Updated WASP Climate Analyst projects with monthly data files have been uploaded to the WASA team site as "WMxx.wcp" files, where xx is the number of the station.

Mast SA01

1. Nothing to report

Mast SA02

1. 2 missing obs. from 2012-01-26 16:40:00 to 2012-01-26 16:50:00 (marked already w/ NULL)

Mast SA03

1. Nothing to report

Mast SA04

1. Nothing to report

Mast SA05

1. Nothing to report

Mast SA06

1. Nothing to report

Mast SA07

1. Nothing to report

Mast SA08

1. Nothing to report

Mast SA09

1. Nothing to report

Mast SA10

1. Nothing to report

Wind Atlas for South Africa – QA of meteorological data February 2012

Niels G. Mortensen, Wind Energy Department, DTU Risø Campus

Meteorological data for February 2012 from the 10 WASA stations have been screened with the purpose of assuring the quality of the data. The screening comprises mean wind speed and direction from 5 levels, as well as mean temperature, temperature difference, pressure and relative humidity; visual inspection of all parameters at the WASA Rodeo site is not included in the present screening. Missing observations and erroneous values are flagged with dummy values (-9999.999); in the final download files such values will be flagged as 'NULL'. Updated WASP Climate Analyst projects with monthly data files have been uploaded to the WASA team site as "WMxx.wcp" files, where xx is the number of the station.

Mast SA01

1. 1 missing obs. at 2012-02-07 15:20:00 (marked already w/ NULL)

Mast SA02

1. Nothing to report

Mast SA03

2. Nothing to report

Mast SA04

1. Nothing to report

Mast SA05

1. Nothing to report

Mast SA06

1. Six unrealistic observations of ΔT (4 channels): 2012-02-05 17:00:00 to 2012-02-05 17:50:00.
No idea what has happened, but these obs. are in error (four NULL's were already in the file).

Mast SA07

1. Nothing to report

Mast SA08

1. Nothing to report

Mast SA09

1. Nothing to report

Mast SA10

1. Many bad obs. from 2012-02-17 22:30:00 and onwards:
 - U_40: 848 erroneous obs. from 2012-02-17 23:30:00 and onwards
 - U_20: all obs. bad from 2012-02-17 22:30:00 and onwards
 - U_10: 848 erroneous obs. from 2012-02-17 23:30:00 and onwards
2. Last valid data at all is 2012-02-28 07:40:00, i.e. 242 missing observations at the end of the file. **We might want to do the QA again when the station has been visited and the data logger retrieved.**

Wind Atlas for South Africa – QA of meteorological data March 2012

Niels G. Mortensen, Wind Energy Department, DTU Risø Campus

Meteorological data for March 2012 from the 10 WASA stations have been screened with the purpose of assuring the quality of the data. The screening comprises mean wind speed and direction from 5 levels, as well as mean temperature, temperature difference, pressure and relative humidity; visual inspection of all parameters at the WASA Rodeo site is not included in the present screening. Missing observations and erroneous values are flagged with dummy values (-9999.999); in the final download files such values will be flagged as 'NULL'. Updated WASP Climate Analyst projects with monthly data files have been uploaded to the WASA team site as "WMxx.wcp" files, where xx is the number of the station.

Mast SA01

1. Nothing to report

Mast SA02

2. Nothing to report

Mast SA03

3. Nothing to report

Mast SA04

1. Nothing to report

Mast SA05

1. Nothing to report

Mast SA06

1. Nothing to report

Mast SA07

1. Nothing to report

Mast SA08

1. Nothing to report

Mast SA09

1. Nothing to report

Mast SA10

1. Station out of operation – no data, all NULL values

Wind Atlas for South Africa – QA of meteorological data April 2012

Niels G. Mortensen, Wind Energy Department, DTU Risø Campus

Meteorological data for April 2012 from the 10 WASA stations have been screened with the purpose of assuring the quality of the data. The screening comprises mean wind speed and direction from 5 levels, as well as mean temperature, temperature difference, pressure and relative humidity; visual inspection of all parameters at the WASA Rodeo site is not included in the present screening. Missing observations and erroneous values are flagged with dummy values (-9999.999); in the final download files such values will be flagged as 'NULL'. Updated WASP Climate Analyst projects with monthly data files have been uploaded to the WASA team site as "WMxx.wcp" files, where xx is the number of the station.

Mast SA01

1. Nothing to report

Mast SA02

1. Nothing to report

Mast SA03

1. Nothing to report

Mast SA04

1. Nothing to report

Mast SA05

1. Some negative wind directions @ 60 m (40 obs.) and @ 20 m (37 obs.) – what's the story?

Mast SA06

1. Nothing to report

Mast SA07

1. Nothing to report

Mast SA08

1. Nothing to report

Mast SA09

1. Nothing to report

Mast SA10

1. Station out of operation – no data, all NULL values

Wind Atlas for South Africa – QA of meteorological data May 2012

Niels G. Mortensen, Wind Energy Department, DTU Risø Campus

Meteorological data for May 2012 from the 10 WASA stations have been screened with the purpose of assuring the quality of the data. The screening comprises mean wind speed and direction from 5 levels, as well as mean temperature, temperature difference, pressure and relative humidity; visual inspection of all parameters at the WASA Rodeo site is not included in the present screening. Missing observations and erroneous values are flagged with dummy values (-9999.999); in the final download files such values will be flagged as 'NULL'. Updated WASP Climate Analyst projects with monthly data files have been uploaded to the WASA team site as "WMxx.wcp" files, where xx is the number of the station.

Mast SA01

1. Nothing to report

Mast SA02

1. Nothing to report

Mast SA03

1. Nothing to report

Mast SA04

1. Nothing to report

Mast SA05

1. Nothing to report

Mast SA06

1. Nothing to report

Mast SA07

1. Nothing to report

Mast SA08

1. Nothing to report

Mast SA09

1. Nothing to report

Mast SA10

1. Station out of operation – no data, all NULL values

Wind Atlas for South Africa – QA of meteorological data June 2012

Niels G. Mortensen, Wind Energy Department, DTU Risø Campus

Meteorological data for June 2012 from the 10 WASA stations have been screened with the purpose of assuring the quality of the data. The screening comprises mean wind speed and direction from 5 levels, as well as mean temperature, temperature difference, pressure and relative humidity; visual inspection of all parameters at the WASA Rodeo site is not included in the present screening. Missing observations and erroneous values are flagged with dummy values (-9999.999); in the final download files such values will be flagged as 'NULL'. Updated WASP Climate Analyst projects with monthly data files have been uploaded to the WASA team site as "WMxx.wcp" files, where xx is the number of the station.

Mast SA01

1. Nothing to report

Mast SA02

1. Nothing to report

Mast SA03

1. Nothing to report

Mast SA04

1. Nothing to report

Mast SA05

1. Nothing to report

Mast SA06

1. Nothing to report

Mast SA07

1. Nothing to report

Mast SA08

1. Nothing to report

Mast SA09

1. Nothing to report

Mast SA10

1. Station out of operation – no data, all NULL values

Wind Atlas for South Africa – QA of meteorological data July 2012

Niels G. Mortensen, Wind Energy Department, DTU Risø Campus

Meteorological data for July 2012 from the 10 WASA stations have been screened with the purpose of assuring the quality of the data. The screening comprises mean wind speed and direction from 5 levels, as well as mean temperature, temperature difference, pressure and relative humidity; visual inspection of all parameters at the WASA Rodeo site is not included in the present screening. Missing observations and erroneous values are flagged with dummy values (-9999.999); in the final download files such values will be flagged as 'NULL'. Updated WASP Climate Analyst projects with monthly data files have been uploaded to the WASA team site as "WMxx.wcp" files, where xx is the number of the station.

Mast SA01

1. Nothing to report

Mast SA02

1. Nothing to report

Mast SA03

1. Nothing to report

Mast SA04

1. Nothing to report

Mast SA05

1. Nothing to report

Mast SA06

1. WS_62 and WS_60 unrealistic (frozen?) 2012-07-13 12:00 to 2012-07-14 15:20 ⇒ NULL
2. WS_40 and WS_20 uncertain from 2012-07-13 21:20 to end of file ⇒ NULL
3. WS_10 unrealistic (frozen?) 2012-07-13 21:20 to 2012-07-14 15:20 ⇒ NULL
4. WD_60 unrealistic (frozen?) 2012-07-13 17:40 to 2012-07-14 13:20 ⇒ NULL
5. WD_20 unrealistic (frozen?) 2012-07-13 19:30 to 2012-07-14 13:20 ⇒ NULL

Mast SA07

1. Nothing to report

Mast SA08

1. Nothing to report

Mast SA09

1. WS_62 and WS_60 unrealistic (frozen?) 2012-07-13 11:20 to 2012-07-15 14:50 ⇒ NULL
2. WS_40 and WS_20 unrealistic (frozen?) 2012-07-13 12:20 to 2012-07-15 12:50 ⇒ NULL
3. WS_10 unrealistic (frozen?) 2012-07-13 14:20 to 2012-07-15 10:10 ⇒ NULL
4. WD_60 and WD_20 unrealistic (frozen?) 2012-07-13 07:50 to 2012-07-14 22:00 ⇒ NULL

Wind Atlas for South Africa – QA of meteorological data August 2012

Niels G. Mortensen, Wind Energy Department, DTU Risø Campus

Meteorological data for August 2012 from the 10 WASA stations have been screened with the purpose of assuring the quality of the data. The screening comprises mean wind speed and direction from 5 levels, as well as mean temperature, temperature difference, pressure and relative humidity; visual inspection of all parameters at the WASA Rodeo site is not included in the present screening. Missing observations and erroneous values are flagged with dummy values (-9999.999); in the final download files such values will be flagged as 'NULL'. Updated WASP Climate Analyst projects with monthly data files have been uploaded to the WASA team site as "WMxx.wcp" files, where xx is the number of the station.

Mast SA01

1. Nothing to report

Mast SA02

1. Nothing to report

Mast SA03

1. Nothing to report

Mast SA04

1. Nothing to report

Mast SA05

1. Nothing to report

Mast SA06

1. WS_40 (4 channels) unrealistic from 2012-08-01 00:10 to 2012-08-03 06:40 ⇒ NULL
2. Rh not limited to '<= 100'; calibration expression not applied/working?

Mast SA07

1. Nothing to report

Mast SA08

1. Nothing to report

Mast SA09

1. Rh not limited to '<= 100'; calibration expression not applied/working?

Mast SA10

1. WS_62 + WS_60 + WD_60 + Tair + Pbaro + RH active only (4 channels each), all other channels should contain NULL values in entire file.
2. Rh not limited to '<= 100'; calibration expression not applied/working?

All stations

1. Is Rh not limited to '<= 100'; calibration expression not applied/working?

Wind Atlas for South Africa – QA of meteorological data September 2012

Niels G. Mortensen, Wind Energy Department, DTU Risø Campus

Meteorological data for September 2012 from the 10 WASA stations have been screened with the purpose of assuring the quality of the data. The screening comprises mean wind speed and direction from 5 levels, as well as mean temperature, temperature difference, pressure and relative humidity; visual inspection of all parameters at the WASA Rodeo site is not included in the present screening. Missing observations and erroneous values are flagged with dummy values (-9999.999); in the final download files such values will be flagged as 'NULL'. Updated WASP Climate Analyst projects with monthly data files have been uploaded to the WASA team site as "WMxx.wcp" files, where xx is the number of the station.

Mast SA01

1. Nothing to report

Mast SA02

1. Nothing to report

Mast SA03

1. Nothing to report

Mast SA04

1. Nothing to report

Mast SA05

1. Nothing to report

Mast SA06

1. Nothing to report

Mast SA07

1. Nothing to report

Mast SA08

1. Nothing to report

Mast SA09

1. Nothing to report

Mast SA10

1. Nothing to report
2. WS_62 + WS_60 + WD_60 + Tair + Pbaro + Rh active only (4 channels each), all other channels should contain NULL values in entire file.

All stations

1. Nothing to report

Wind Atlas for South Africa – QA of data – October 2012

Eric Prinsloo, CSIR, Stellenbosch

Meteorological data for the period October 2012 from the 10 WASA stations have been screened with the purpose of assuring the quality of the data. The screening comprises mean wind speed and direction from 5 levels using the WASP Climate Analyst program. Secondly the graphs of all means, maximums and minimums of all 5 anemometers, temperature (Tair), atmospheric pressure (PB), Temperature Gradient (Tgrad), and relative humidity (RH) are checked for irregularities; comparing these with graphs of the standard deviations (SD) of all parameters. Visual inspection of all parameters on the WASA Rodeo online graph site is done to verify any potential irregularities. Missing observations and erroneous values are flagged with dummy values (-9999.999); in the final download files such values will be flagged as 'null'. Updated WASP Climate Analyst projects with monthly data files have been uploaded to the WASA team site as "WMxx_XXXxxx.wcp" files, where xx is the number of the station, and XXXxxx the month and year.

Mast SA01

1. Nothing to report

Mast SA02

1. Nothing to report

Mast SA03

1. Nothing to report

Mast SA04

1. Nothing to report

Mast SA05

1. Nothing to report

Mast SA06

1. Nothing to report

Mast SA07

1. Nothing to report

Mast SA08

1. Nothing to report

Mast SA09

1. Nothing to report

Mast SA10

1. Nothing to report
2. Only WS_62 + WS_60 + WD_60 + Tair + Pbaro + Rh active (4 channels each), all other channels to contain NULL values in entire file.

Wind Atlas for South Africa – QA of data – November 2012

Eric Prinsloo, CSIR, Stellenbosch

Meteorological data for the period November 2012 from the 10 WASA stations have been screened with the purpose of assuring the quality of the data. The screening comprises mean wind speed and direction from 5 levels using the WAsP Climate Analyst program. Secondly the graphs of all means, maximums and minimums of all 5 anemometers, temperature (Tair), atmospheric pressure (PB), Temperature Gradient (Tgrad), and relative humidity (RH) are checked for irregularities; comparing these with graphs of the standard deviations (SD) of all parameters. Visual inspection of all parameters on the WASA Rodeo online graph site is done to verify any potential irregularities. Missing observations and erroneous values are flagged with dummy values (-9999.999); in the final download files such values will be flagged as 'null'. Updated WAsP Climate Analyst projects with monthly data files have been uploaded to the WASA team site as "WMxx_XXXxxxx.wcp" files, where xx is the number of the station, and XXXxxxx the month and year.

Mast SA01

1. Nothing to report

Mast SA02

1. Nothing to report

Mast SA03

1. Nothing to report

Mast SA04

1. T and RH sensor disturbed when new navlights were installed. Data of Tair from 12:50 to 14:00 on 8 Nov was nullified, as well as maximum PB and SD for 13:00 on 8 Nov. Otherwise nothing to report.

Mast SA05

1. 40m Anemometer starting to pack up at low speeds. Data from 21:40 to 23:40 on 26 Nov was nullified.

Mast SA06

1. Nothing to report

Mast SA07

1. Nothing to report

Mast SA08

1. Nothing to report

Mast SA09

1. Nothing to report

Mast SA10

1. Nothing to report

Wind Atlas for South Africa – QA of data – December 2012

Eric Prinsloo, CSIR, Stellenbosch

Meteorological data for the period December 2012 from the 10 WASA stations have been screened with the purpose of assuring the quality of the data. The screening comprises mean wind speed and direction from 5 levels using the WASP Climate Analyst program. Secondly the graphs of all means, maximums and minimums of all 5 anemometers, temperature (Tair), atmospheric pressure (PB), Temperature Gradient (Tgrad), and relative humidity (RH) are checked for irregularities; comparing these with graphs of the standard deviations (SD) of all parameters. Visual inspection of all parameters on the WASA Rodeo online graph site is done to verify any potential irregularities. Missing observations and erroneous values are flagged with dummy values (-9999.999); in the final download files such values will be flagged as 'null'. Updated WASP Climate Analyst projects with monthly data files have been uploaded to the WASA team site as "WMxx_XXXxxx.wcp" files, where xx is the number of the station, and XXXxxx the month and year.

Mast SA01

1. Nothing to report

Mast SA02

1. Hail damage to 62m anemometer (one cup missing). Data from 05:10 on 0 Dec to end of month was nullified. Nothing else to report.

Mast SA03

1. Nothing to report

Mast SA04

1. Nothing to report.

Mast SA05

1. 40m Anemometer readings increasingly erratic. Data from 09:50 to 21:40 on 17 Dec; 07:50 to 13:00 on 18 Dec; 19:10 on 21 Dec to 03:10 on 22 Dec; 12:30 on 22 Dec to 11:20 on 27 Dec; and 14:40 on 27 Dec to end of Dec was nullified. Nothing else to report.

Mast SA06

1. Some spikes in Tgrad were nullified i.e. 15:10 - 18:50 on 16 Dec; 15:50 - 17:10 on 17 Dec; 15:00 - 19:10 on 18 Dec; 17:00 - 18:00 on 19 Dec; 14:50 - 19:20 on 20 Dec, 14:20 - 18:30 on 22 Dec; and 18:10 on 26 Dec. Nothing further to report

Mast SA07

1. Nothing to report

Mast SA08

1. 62m Anemometer data from 19:10 on 15 Dec to end of Dec was nullified – possible lightning surge damaged bearings. Nothing else to report

Mast SA09

1. Nothing to report

Wind Atlas for South Africa – QA of data – January 2013

Eric Prinsloo, CSIR, Stellenbosch

Meteorological data for the period January 2013 from the 10 WASA stations have been screened with the purpose of assuring the quality of the data. The screening comprises mean wind speed and direction from 5 levels using the WAsP Climate Analyst program. Secondly the graphs of all means, maximums and minimums of all 5 anemometers, temperature (Tair), atmospheric pressure (PB), Temperature Gradient (Tgrad), and relative humidity (RH) are checked for irregularities; comparing these with graphs of the standard deviations (SD) of all parameters. Visual inspection of all parameters on the WASA Rodeo online graph site is done to verify any potential irregularities. Missing observations and erroneous values are flagged with dummy values (-9999.999); in the final download files such values will be flagged as 'null'. Updated WAsP Climate Analyst projects with monthly data files have been uploaded to the WASA team site as "WMxx_XXXxxx.wcp" files, where xx is the number of the station, and XXXxxx the month and year.

Mast SA01

1. Nothing to report

Mast SA02

1. 62m Anemometer data for whole of Jan. was nullified. Nothing else to report.

Mast SA03

1. Nothing to report

Mast SA04

1. Nothing to report.

Mast SA05

1. 40m Anemometer data from start of month up to 11:50 on 23 Jan. was nullified. New anemometer was installed on 23 Jan. Nothing else to report.

Mast SA06

1. Some spikes in Tgrad were nullified i.e. 15:50 - 18:50 on 5 Jan; 15:40 - 18:50 on 7 Jan; 15:40 - 18:30 on 15 Jan; 12:40 - 19:00 on 16 Jan; 16:30 - 18:10 on 20 Jan, 14:30 - 20:00 on 22 Jan; 14:50 - 19:10 on 23 Jan, and 17:30 - 17:50 on 26 Jan. Spikes possible to loose connection as it only happens when Tair goes above $\pm 24^{\circ}\text{C}$. Nothing further to report.

Mast SA07

1. Nothing to report

Mast SA08

1. All 62m anemometer data for Jan was nullified. Nothing else to report

Mast SA09

1. Nothing to report

Mast SA10

1. All RH data was nullified, as well as some "zero" Tgrad values that slipped in. Nothing further to report

Wind Atlas for South Africa – QA of data – February 2013

Eric Prinsloo, CSIR, Stellenbosch

Meteorological data for the period February 2013 from the 10 WASA stations have been screened with the purpose of assuring the quality of the data. The screening comprises mean wind speed and direction from 5 levels using the WASP Climate Analyst program. Secondly the graphs of all means, maximums and minimums of all 5 anemometers, temperature (Tair), atmospheric pressure (PB), Temperature Gradient (Tgrad), and relative humidity (RH) are checked for irregularities; comparing these with graphs of the standard deviations (SD) of all parameters. Visual inspection of all parameters on the WASA Rodeo online graph site is done to verify any potential irregularities. Missing observations and erroneous values are flagged with dummy values (-9999.999); in the final download files such values will be flagged as 'null'. Updated WASP Climate Analyst projects with monthly data files have been uploaded to the WASA team site as "WMxx_XXXxxx.wcp" files, where xx is the number of the station, and XXXxxx the month and year.

Mast SA01

1. 10m Anemometer data for 11:00 and 11:10, and 16:30 and 16:40 on 1 Feb was nullified, as well as 20m anemometer data for 15:30 – 15:50 on 9 Feb. Nothing else to report

Mast SA02

1. 62m Anemometer data for 1 to 01:10 on 20 Feb was nullified. Nothing else to report.

Mast SA03

1. Nothing to report

Mast SA04

1. Nothing to report.

Mast SA05

1. . Nothing to report.

Mast SA06

1. Some spikes in Tgrad were nullified i.e. 15:50 - 19:10 on 1 Feb; 16:50 - 18:20 on 2 Feb; 16:00 - 18:40 on 8 Feb; 16:30 - 19:00 on 12 Feb; 16:00 – 18:00 on 13 Feb, 17:00 – 17:50 on 17 Feb; 16:00 – 18:20 on 25 Feb, and 16:30 on 26 Feb. Spikes possible to loose connection as it only happens when Tair goes above $\pm 24^{\circ}\text{C}$. Nothing further to report.

Mast SA07

1. Nothing to report

Mast SA08

1. All 62m anemometer data for Feb was nullified. Nothing else to report

Mast SA09

1. Nothing to report

Mast SA10

1. All RH data was nullified. Nothing further to report

Wind Atlas for South Africa – QA of data – March 2013

Eric Prinsloo, CSIR, Stellenbosch

Meteorological data for the period March 2013 from the 10 WASA stations have been screened with the purpose of assuring the quality of the data. The screening comprises mean wind speed and direction from 5 levels using the WASP Climate Analyst program. Secondly the graphs of all means, maximums and minimums of all 5 anemometers, temperature (Tair), atmospheric pressure (PB), Temperature Gradient (Tgrad), and relative humidity (RH) are checked for irregularities; comparing these with graphs of the standard deviations (SD) of all parameters. Visual inspection of all parameters on the WASA Rodeo online graph site is done to verify any potential irregularities. Missing observations and erroneous values are flagged with dummy values (-9999.999); in the final download files such values will be flagged as 'null'. Updated WASP Climate Analyst projects with monthly data files have been uploaded to the WASA team site as "WMxx_XXXxxx.wcp" files, where xx is the number of the station, and XXXxxx the month and year.

Mast SA01

1. 40m Anemometer data for 16:00 to 16:20 was nullified. Nothing else to report

Mast SA02

1. Nothing to report.

Mast SA03

1. Nothing to report

Mast SA04

1. Nothing to report.

Mast SA05

1. . Nothing to report.

Mast SA06

1. Nothing to report.

Mast SA07

1. 62m Anemometer damaged by hail. Data from 17:50 on 27 Mar to end of month was nullified. Nothing else to report.

Mast SA08

1. All 62m anemometer data for Mar was nullified. Nothing else to report

Mast SA09

1. Nothing to report

Mast SA10

1. All RH data was nullified. Nothing further to report

Wind Atlas for South Africa – QA of data – April 2013

Eric Prinsloo, CSIR, Stellenbosch

Meteorological data for the period April 2013 from the 10 WASA stations have been screened with the purpose of assuring the quality of the data. The screening comprises mean wind speed and direction from 5 levels using the WASP Climate Analyst program. Secondly the graphs of all means, maximums and minimums of all 5 anemometers, temperature (Tair), atmospheric pressure (PB), Temperature Gradient (Tgrad), and relative humidity (RH) are checked for irregularities; comparing these with graphs of the standard deviations (SD) of all parameters. Visual inspection of all parameters on the WASA Rodeo online graph site is done to verify any potential irregularities. Missing observations and erroneous values are flagged with dummy values (-9999.999); in the final download files such values will be flagged as 'null'. Updated WASP Climate Analyst projects with monthly data files have been uploaded to the WASA team site as "WMxx_XXXxxx.wcp" files, where xx is the number of the station, and XXXxxx the month and year.

Mast SA01

1. Nothing to report

Mast SA02

1. Nothing to report.

Mast SA03

1. Nothing to report

Mast SA04

1. Nothing to report.

Mast SA05

1. . Nothing to report.

Mast SA06

1. Nothing to report.

Mast SA07

1. 62m Anemometer was nullified from start of month to 13:50 on 29 Apr. Nothing else to report.

Mast SA08

1. All 62m anemometer data for Apr was nullified. Nothing else to report

Mast SA09

1. Nothing to report

Mast SA10

1. All RH data was nullified. Nothing further to report

Wind Atlas for South Africa – QA of data – May 2013

Eric Prinsloo, CSIR, Stellenbosch

Meteorological data for the period May 2013 from the 10 WASA stations have been screened with the purpose of assuring the quality of the data. The screening comprises mean wind speed and direction from 5 levels using the WASP Climate Analyst program. Secondly the graphs of all means, maximums and minimums of all 5 anemometers, temperature (Tair), atmospheric pressure (PB), Temperature Gradient (Tgrad), and relative humidity (RH) are checked for irregularities; comparing these with graphs of the standard deviations (SD) of all parameters. Visual inspection of all parameters on the WASA Rodeo online graph site is done to verify any potential irregularities. Missing observations and erroneous values are flagged with dummy values (-9999.999); in the final download files such values will be flagged as 'null'. Updated WASP Climate Analyst projects with monthly data files have been uploaded to the WASA team site as "WMxx_XXXxxx.wcp" files, where xx is the number of the station, and XXXxxx the month and year.

Mast SA01

1. Nothing to report

Mast SA02

1. Nothing to report.

Mast SA03

1. Nothing to report

Mast SA04

1. Nothing to report.

Mast SA05

1. Nothing to report.

Mast SA06

1. Nothing to report.

Mast SA07

1. Nothing to report.

Mast SA08

1. 62m Anemometer data from 1 May to 11:20 on 2 May was nullified. Nothing else to report

Mast SA09

1. Nothing to report

Mast SA10

1. All data on 1 May from 11:20 to 11:50 was nullified (worked on data logger). Nothing further to report

Wind Atlas for South Africa – QA of data – June 2013

Eric Prinsloo, CSIR, Stellenbosch

Meteorological data for the period June 2013 from the 10 WASA stations have been screened with the purpose of assuring the quality of the data. The screening comprises mean wind speed and direction from 5 levels using the WAsP Climate Analyst program. Secondly the graphs of all means, maximums and minimums of all 5 anemometers, temperature (Tair), atmospheric pressure (PB), Temperature Gradient (Tgrad), and relative humidity (RH) are checked for irregularities; comparing these with graphs of the standard deviations (SD) of all parameters. Visual inspection of all parameters on the WASA Rodeo online graph site is done to verify any potential irregularities. Missing observations and erroneous values are flagged with dummy values (-9999.999); in the final download files such values will be flagged as 'null'. Updated WAsP Climate Analyst projects with monthly data files have been uploaded to the WASA team site as "WMxx_XXXxxx.wcp" files, where xx is the number of the station, and XXXxxx the month and year.

Mast SA01

1. Nothing to report

Mast SA02

1. Nothing to report.

Mast SA03

1. Nothing to report

Mast SA04

1. No data after 22:40 on 6 Jun. Mast was vandalised.

Mast SA05

1. Nothing to report.

Mast SA06

1. Nothing to report.

Mast SA07

1. Nothing to report.

Mast SA08

1. Nothing to report

Mast SA09

1. Nothing to report

Mast SA10

1. Nothing to report

Wind Atlas for South Africa – QA of data – July 2013

Eric Prinsloo, CSIR, Stellenbosch

Meteorological data for the period July 2013 from the 10 WASA stations have been screened with the purpose of assuring the quality of the data. The screening comprises mean wind speed and direction from 5 levels using the WASP Climate Analyst program. Secondly the graphs of all means, maximums and minimums of all 5 anemometers, temperature (Tair), atmospheric pressure (PB), Temperature Gradient (Tgrad), and relative humidity (RH) are checked for irregularities; comparing these with graphs of the standard deviations (SD) of all parameters. Visual inspection of all parameters on the WASA Rodeo online graph site is done to verify any potential irregularities. Missing observations and erroneous values are flagged with dummy values (-9999.999); in the final download files such values will be flagged as 'null'. Updated WASP Climate Analyst projects with monthly data files have been uploaded to the WASA team site as "WMxx_XXXxxx.wcp" files, where xx is the number of the station, and XXXxxx the month and year.

Mast SA01

1. Nothing to report

Mast SA02

1. Nothing to report.

Mast SA03

1. Nothing to report

Mast SA04

1. No data. Mast was vandalised.

Mast SA05

1. Nothing to report.

Mast SA06

1. Nothing to report.

Mast SA07

1. Nothing to report.

Mast SA08

1. Nothing to report

Mast SA09

1. Nothing to report

Mast SA10

1. Nothing to report

Wind Atlas for South Africa – QA of data – August 2013

Eric Prinsloo, CSIR, Stellenbosch

Meteorological data for the period August 2013 from the 10 WASA stations have been screened with the purpose of assuring the quality of the data. The screening comprises mean wind speed and direction from 5 levels using the WASP Climate Analyst program. Secondly the graphs of all means, maximums and minimums of all 5 anemometers, temperature (Tair), atmospheric pressure (PB), Temperature Gradient (Tgrad), and relative humidity (RH) are checked for irregularities; comparing these with graphs of the standard deviations (SD) of all parameters. Visual inspection of all parameters on the WASA Rodeo online graph site is done to verify any potential irregularities. Missing observations and erroneous values are flagged with dummy values (-9999.999); in the final download files such values will be flagged as 'null'. Updated WASP Climate Analyst projects with monthly data files have been uploaded to the WASA team site as "WMxx_XXXxxx.wcp" files, where xx is the number of the station, and XXXxxx the month and year.

Mast SA01

1. Nothing to report

Mast SA02

1. Nothing to report.

Mast SA03

1. Nothing to report

Mast SA04

1. No data. Mast was vandalised.

Mast SA05

1. Nothing to report.

Mast SA06

1. Data of 20m and 40m anemometers 09:00 – 10:40 on 7th was nullified due to snow. Data of 60m WD nullified from 18:00 on 7th to 10:40 on 8th, and 20m WD nullified from 01:10 to 10:20 on 8th of Aug. Nothing else to report.

Mast SA07

1. Nothing to report.

Mast SA08

1. Nothing to report

Mast SA09

1. Data of 60mWD from 04:50 to 6:50 on 10th was nullified due to snow. Also on 10th the 20m WD data was nullified from 03:50 to 08:00. Nothing else to report

Mast SA10

1. Nothing to report

Wind Atlas for South Africa – QA of data – September 2013

Eric Prinsloo, CSIR, Stellenbosch

Meteorological data for the period September 2013 from the 10 WASA stations have been screened with the purpose of assuring the quality of the data. The screening comprises mean wind speed and direction from 5 levels using the WASP Climate Analyst program. Secondly the graphs of all means, maximums and minimums of all 5 anemometers, temperature (Tair), atmospheric pressure (PB), Temperature Gradient (Tgrad), and relative humidity (RH) are checked for irregularities; comparing these with graphs of the standard deviations (SD) of all parameters. Visual inspection of all parameters on the WASA Rodeo online graph site is done to verify any potential irregularities. Missing observations and erroneous values are flagged with dummy values (-9999.999); in the final download files such values will be flagged as 'null'. Updated WASP Climate Analyst projects with monthly data files have been uploaded to the WASA team site as "WMxx_XXXxxx.wcp" files, where xx is the number of the station, and XXXxxx the month and year.

Mast SA01

1. Nothing to report

Mast SA02

1. Nothing to report.

Mast SA03

1. Nothing to report

Mast SA04

1. No data. Mast was vandalised.

Mast SA05

1. Nothing to report.

Mast SA06

1. Nothing to report.

Mast SA07

1. Nothing to report.

Mast SA08

1. Nothing to report

Mast SA09

1. Nothing to report

Mast SA10

1. Nothing to report

ANNEXURE G

Sensor Specifications

P2546A Cup Anemometer

Features

- Low threshold speed
- Low distance constant
- Negligible overspeeding
- Angular response independent of wind speed
- Fully tested temperature performance
- Symmetrical geometry
- No external power source
- Bounce free reed switch

Description

The P2546A Cup Anemometer is a sturdy wind sensor solely constructed by durable materials such as anodized aluminium and stainless steel.

The wind speed is sensed by a three-cup rotor assembly. Permanent magnets mounted on the shaft causes a switch to close and open two times per revolution.

The switch has no bounce and it is equipped with a special built-in mechanism, which reduces the variation in operating time over the frequency range. This feature provides the possibility of obtaining the instantaneous wind speed by measuring the time interval of each revolution.

Specifications

Measuring range	0...70 m/s
Starting threshold	< 0.4 m/s
Distance constant	$\lambda_0 = 1.81 \pm 0.04$ m
Standard Calibration	$U = A_0 + B_0 \times f$
Wind speed	U [m/s]
Offset ("starting speed")	$A_0 = 0.27$ m/s
Gain	$B_0 = 0.6201$ m
Output frequency	f [Hz]
Standard deviation of offset	0.014 m/s
Standard deviation of gain	0.027 m
Variation among units	$\pm 1\%$
Nonlinearity	<0.04 m/s
Temperature influence, -15...60°C	< 0.05 m/s

Switching characteristics

Signal type	potential free contact closure
Duty cycle	40...60%
Max switching voltage	30 V
Max. recommended switching current	10 mA
Series resistance	330 Ω , 1 W
Operating temperature range	-35...60°C



The specifications are based on 80 wind tunnel calibrations performed according to the Measnet Cup Anemometer Calibration Procedure.

The specified offset and gain figures represent the mean values of these calibrations.

Variation among units designates the maximum deviation of any unit from the straight line representing these mean values.

All units are run-in for 225 hours at 9 m/s, in order to reduce the initial bearing friction to a level close to the steady state value.

After run-in, bearing friction is tested at -15 °C and at room temperature. The allowed limits for this test assures that the temperature influence on the calibration is within the specified limit.

POTENTIOMETER WINDVANE

W200P

This instrument incorporates a precision wire-wound potentiometer as shaft angle transducer, enabling wind direction to be accurately determined when used in suitable electronic circuits. The potentiometer has the lowest possible torque consistent with long life and reliability, the small gap at north being filled with an insulating material to ensure smooth operation over the full 360°. The vane-arm assembly is attached by the unique Porton™ gravity fastener, allowing rapid attachment and release; thus improving portability.

Construction is from anodised aluminium alloys and stainless steels for exposed parts. Combined with the hard plastic (upper) plain bearing and precision ball races, the result is an instrument with a long service interval which is suitable for permanent exposure to the weather.

In the marine version,^{#1} body/fin sealing is enhanced and a touching shaft-seal is fitted above the upper (replaceable) bearing for extra protection.

For applications where improved sensitivity is required, a larger vane version^{#2} is available.

An anti-icing heater can also be fitted to extend operation by removing hoare frost around the upper bearing.



Range of Operation

Maximum Wind Speed: Over 75m/s (150Knots, 170mph) [60m/s]^{#2}
 Range: 360° mechanical angle, full-circle continuous rotation allowed.
 Temperature range: -50 to +70°C

Performance

Threshold: 0.6m/s (1.2Knot, 1.4mph) [0.75m/s]^{#1} [0.5m/s]^{#2}
 (the vane will commence movement when aligned at 45° to the flow).
 Response: Damped natural Wavelength: 3.4m [3.6m]^{#2} Damping Ratio: 0.2m [0.24m]^{#2}
 Recovery distance: 0.51m [0.54m]^{#2} Distance constant: 2.3m [2.4m]^{#2}
 Repeatability: ±0.5° vane removed and replaced (no measurable backlash movement during use).
 Life of potentiometer: 5 x 10⁷ cycles (10 years typical exposure).
 Service Interval: 4 to 5 years.
 Accuracy: ±3° in steady winds >5m/s [6m/s]^{#1} [3.5m/s]^{#2} (±2° obtainable following calibration).

Electrical

Potentiometer resistance: 1000 Ω ±10%
 Maximum dissipation: 0.5W, -50 to +20°C (de-rate linearly to 0.25W at 70°C)
 Maximum wiper current: 50µA*, (20mA absolute max.)
 Supply voltage: 1 to 5V*, (20V absolute max.) across terminals 1 & 3.
 Case to pot. voltage: 72V max. (case or screen to any terminal on pot.)
 Insulation resistance: >50MΩ
 Temperature coefficient of resistance: ±50 x 10⁻⁶/°C
 Electrical continuity angle: 357.7 ±1.5° (2.3° gap at north)
 Electrical variation angle: 356.5 ±1.5° (3.5° dead-band)
 Resolution: ±0.2°
 Independent non-linearity: ±0.25% (unloaded)

Notes: Figures marked * refer to recommended operating conditions.

Bracketed figures marked ^{#1,#2} refer to parameters changed when options are fitted. (see options section overleaf).

 Vector Instruments

HMP45C

Temperature and Relative Humidity Probe



The HMP45C is a rugged, accurate temperature/RH probe manufactured by Vaisala Inc., that is ideal for long-term, unattended applications. The probe uses a capacitive polymer H chip to measure RH and a PRT to measure temperature.

To reduce the current drain, power can be supplied to the HMP45C only during measurement when the sensor is connected to the datalogger's switched 12 V terminal. Dataloggers that do not have a switched 12 V terminal, such as the CR510 or CR7, can use the SW12V Switched 12 V device to switch power to the sensor only during measurement. For optimum results, the HMP45C should be recalibrated annually.

Sensor Mounts

The 41003-5 radiation shield should be used when the HMP45C is exposed to sunlight. The 41003-5 can attach directly to a mast or tower leg or to a CM202, CM204, or CM206 crossarm.

Ordering Information

Air Temperature and Relative Humidity Probe

HMP45C-L Vaisala Temperature/RH Probe with user-specified cable length. Enter cable length, in feet, after the -L. The maximum cable length is 1000 ft. Each 100 ft of cable increases the apparent RH reading by approximately 0.56% RH and the temperature by 0.50°C. Must choose a cable termination option (see below).

Cable Termination Options (choose one)

- PT** Cable terminates in stripped and tinned leads for direct connection to a datalogger's terminals.
- PW** Cable terminates in connector for attachment to a prewired enclosure.

Accessories

SW12V Switched 12 V device that uses a control port and a 12 V channel to switch power to the HMP45C instead of a switched 12 V terminal.

41003-5 10-Plate Gill Radiation Shield to house the HMP45C

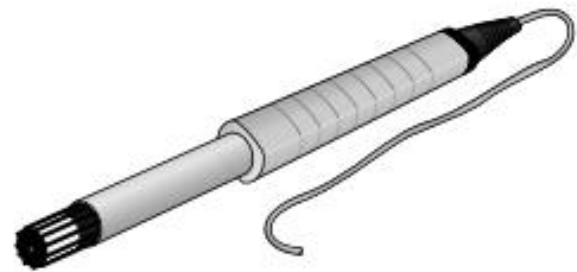

Recommended Cable Lengths

2-m Height		Atop a tripod or tower via a 2-ft crossarm such as the CM202								
Mast/Leg	CM202	CM6	CM106	CM10	CM110	CM115	CM120	UT10	UT20	UT30
9 ft	11 ft	11 ft	14 ft	14 ft	14 ft	19 ft	24 ft	14 ft	24 ft	37 ft

Note: Add two feet to the cable length if mounting the enclosure to the leg base of a CM106, CM110, CM115, or CM120 tripod.

VAISALA

www.valsala.com

PTB110 Barometer for Industrial Use



The Vaisala BAROCAP® Barometer PTB110 offers outstanding long-term stability.

Features/Benefits

- Vaisala BAROCAP® sensor
- Several pressure ranges
- Accuracy ± 0.3 hPa at $+20$ °C
- Long-term stability
- On/off control with external trigger
- Output voltage 0 ... 2.5 or 0 ... 5 VDC
- Current consumption less than 4 mA
- Mountable on a (35 mm wide) DIN rail
- NIST traceable (certificate included)

PTB110

The Vaisala BAROCAP® Barometer PTB110 is designed both for accurate barometric pressure measurements at a room temperature and for general environmental pressure monitoring over a wide temperature range.

Vaisala BAROCAP® Technology

The PTB110 barometer uses the Vaisala BAROCAP® Sensor, a silicon capacitive absolute pressure sensor developed by Vaisala for barometric pressure measurement applications.

The sensor combines the outstanding elasticity characteristics and mechanical stability of single-crystal silicon with the proven capacitive detection principle.

Accuracy and Stability

The excellent long-term stability of the barometer minimizes or even removes the need for field adjustment in many applications.

Applications

The PTB110 is suitable for a variety of applications, such as environmental pressure monitoring, data buoys, laser interferometers, and in agriculture and hydrology.

The compact PTB110 is especially ideal for data logger applications as it has low power consumption. Also an external On/Off control is available. This is practical when the supply of electricity is limited.

CR1000 Specifications

Electrical specifications are valid over a -25° to +50°C, non-condensing environment, unless otherwise specified. Recalibration recommended every three years. Critical specifications and system configuration should be confirmed with Campbell Scientific before purchase.

PROGRAM EXECUTION RATE

10 ms to one day @ 10 ms increments

ANALOG INPUTS (SE1-SE16 or DIFF1-DIFF8)

8 differential (DF) or 16 single-ended (SE) individually configured input channels. Channel expansion provided by optional analog multiplexers.

RANGES and RESOLUTION: Basic resolution (Basic Res) is the A/D resolution of a single A/D conversion. A DIFF measurement with input reversal has better (finer) resolution by twice than Basic Res.

Range (mV) ¹	DF Res (µV) ²	Basic Res (µV)
±5000	667	1333
±2500	333	667
±250	33.3	66.7
±25	3.33	6.7
±7.5	1.0	2.0
±2.5	0.33	0.67

¹Range overhead of 79% on all ranges guarantees that full-scale values will not cause over range.

²Resolution of DF measurements with input reversal.

ACCURACY³:

±(0.06% of reading + offset), 0° to 40°C
 ±(0.12% of reading + offset), -25° to 50°C
 ±(0.18% of reading + offset), -55° to 85°C (-XT only)

³Accuracy does not include the sensor and measurement noise. Offsets are defined as:

Offset for DF w/ input reversal = 1.5*Basic Res + 1.0 µV
 Offset for DF w/o input reversal = 3*Basic Res + 2.0 µV
 Offset for SE = 3*Basic Res + 3.0 µV

ANALOG MEASUREMENT SPEED:

Integration Type/ Code	Integration Time	Settling Time	Total Time ⁴	
			SE w/ No Rev	DF w/ Input Rev
250	250 µs	450 µs	-1 ms	-12 ms
60 Hz ⁵	16.67 ms	3 ms	-20 ms	-40 ms
50 Hz ⁵	20.00 ms	3 ms	-25 ms	-50 ms

⁴Includes 250 µs for conversion to engineering units.
⁵AC line noise filter.

INPUT NOISE VOLTAGE: For DF measurements with input reversal on ±2.5 mV input range (digital resolution dominates for higher ranges).

250 µs Integration: 0.34 µV RMS
 50/60 Hz Integration: 0.19 µV RMS

INPUT LIMITS: ±5 Vdc

DC COMMON MODE REJECTION: >100 dB

NORMAL MODE REJECTION: 70 dB @ 60 Hz when using 60 Hz rejection

INPUT VOLTAGE RANGE W/O MEASUREMENT

CORRUPTION: ±8.0 Vdc max.

SUSTAINED INPUT VOLTAGE W/O DAMAGE: ±16 Vdc max.

INPUT CURRENT: ±1 nA typical, ±0 nA max. @ 50°C;
 ±90 nA @ 85°C

INPUT RESISTANCE: 20 GΩ typical

ACCURACY OF BUILT-IN REFERENCE JUNCTION

THERMISTOR (for thermocouple measurements):

±0.3°C, -25° to 50°C
 ±0.8°C, -55° to 85°C (-XT only)

ANALOG OUTPUTS (VX1-VX3)

3 switched voltage, sequentially active only during measurement.

RANGE AND RESOLUTION:

Channel	Range	Resolution	Current Source/Sink
[VX 1-3]	±2.5 Vdc	0.67 mV	±25 mA

ANALOG OUTPUT ACCURACY (VX):

±(0.06% of setting + 0.8 mV), 0° to 40°C
 ±(0.12% of setting + 0.8 mV), -25° to 50°C
 ±(0.18% of setting + 0.8 mV), -55° to 85°C (-XT only)

VX FREQUENCY SWEEP FUNCTION: Switched outputs provide a programmable sweep frequency, 0 to 2500 mv square waves for exciting vibrating wire transducers.

PERIOD AVERAGE

Any of the 16 SE analog inputs can be used for period averaging. Accuracy is ±(0.01% of reading + resolution), where resolution is 136 ns divided by the specified number of cycles to be measured.

INPUT AMPLITUDE AND FREQUENCY:

Voltage Gain	Input Range (±mV)	Signal (peak to peak)		Min Pulse Width (µV)	Max ⁶ Freq (kHz)
		Min (mV) ⁵	Max (V) ⁷		
1	250	900	10	2.5	200
10	25	10	2	10	50
33	7.5	5	2	62	8
100	2.5	2	2	100	5

⁵Signal centered around Threshold (see PeriodArg() instruction).

⁷With signal centered at the datalogger ground.

⁶The maximum frequency = 1/(twice minimum pulse width) for 50% of duty cycle signals.

RATIOMETRIC MEASUREMENTS

MEASUREMENT TYPES: Provides ratiometric resistance measurements using voltage excitation. 3 switched voltage excitation outputs are available for measurement of 4- and 6-wire full bridges, and 2-, 3-, and 4-wire half bridges. Optional excitation polarity reversal minimizes dc errors.

RATIOMETRIC MEASUREMENT ACCURACY:^{8,10,11}

±(0.04% of Voltage Measurement + Offset)

⁸Accuracy specification assumes excitation reversal for excitation voltages < 1000 mV. Assumption does not include bridge resistor errors and sensor and measurement noise.

¹⁰Estimated accuracy, ΔX (where X is value returned from the measurement with Multiplier = 1, Offset = 0):

BrFull() instruction: ΔX = ΔV₁/V₂
BrFull() instruction: ΔX = 1000·ΔV₁/V₂, expressed as mV·V⁻¹.

ΔV⁹ is calculated from the ratiometric measurement accuracy. See Resistance Measurements Section in the manual for more information.

¹¹Offsets are defined as:

Offset for DFF w/ input reversal = 1.5*Basic Res + 1.0 µV
 Offset for DFF w/o input reversal = 3*Basic Res + 2.0 µV
 Offset for SE = 3*Basic Res + 3.0 µV
 Excitation reversal reduces offsets by a factor of two.

PULSE COUNTERS (P1-P2)

2 inputs individually selectable for switch closure, high frequency pulse, or low-level ac. Independent 24-bit counters for each input.

MAXIMUM COUNTS PER SCAN: 16.7x10⁶

SWITCH CLOSURE MODE:

Minimum Switch Closed Time: 5 ms
 Minimum Switch Open Time: 6 ms
 Max. Bounce Time: 1 ms open w/o being counted

HIGH-FREQUENCY PULSE MODE:

Maximum Input Frequency: 250 kHz
 Maximum Input Voltage: ±20 V
 Voltage Thresholds: Count upon transition from below 0.9 V to above 2.2 V after input filter with 1.2 µs time constant.

LOW-LEVEL AC MODE: Internal ac coupling removes ac offsets up to ±0.5 Vdc.

Input Hysteresis: 12 mV RMS @ 1 Hz
 Maximum ac Input Voltage: ±20 V
 Minimum ac Input Voltage:

Sine Wave (mV RMS)	Range(Hz)
20	1.0 to 20
200	0.5 to 200
2000	0.3 to 10,000
5000	0.3 to 20,000

DIGITAL I/O PORTS (C1-C8)

8 ports software selectable, as binary inputs or control outputs. Provide Provide on/off, pulse width modulation, edge timing, subroutine interrupts / wake up, switch closure pulse counting, high frequency pulse counting, asynchronous communications (UARTs), and SDI 12 communications. SDM communications are also supported.

LOW FREQUENCY MODE MAX: <1 kHz

HIGH-FREQUENCY MODE MAX: 400 kHz

SWITCH-CLOSURE FREQUENCY MAX: 150 Hz

EDGE TIMING RESOLUTION: 540 ns

OUTPUT VOLTAGES (no load): high 5.0 V ±0.1 V; low <0.1

OUTPUT RESISTANCE: 330 Ω

INPUT STATE: high 3.8 to 16 V; low -8.0 to 1.2 V

INPUT HYSTERESIS: 1.4 V

INPUT RESISTANCE: 100 Ω with inputs <6.2 Vdc

220 Ω with inputs >6.2 Vdc

SERIAL DEVICE/RS-232 SUPPORT: 0 TO 5 Vdc UART

SWITCHED 12 VDC (SW-12)

1 independent 12 Vdc unregulated source is switched on and off under program control. Thermal fuse hold current = 900 mA at 20°C, 650 mA at 50°C, 360 mA at 85°C.

CE COMPLIANCE

STANDARD(S) TO WHICH CONFORMITY IS DECLARED:
 IEC61326:2002

COMMUNICATIONS

RS-232 PORTS:

DCE 9-pin: (not electrically isolated) for computer connection or connection of modems not manufactured by Campbell Scientific.

COM1 to COM4: 4 Independent Tx/Rx pairs on control

ports (non-isolated); 0 to 5 Vdc UART

Baud Rates: selectable from 300 bps to 115.2 kbps.

Default Format: 8 data bits; 1 stop bits; no parity

Optional Formats: 7 data bits; 2 stop bits; odd, even parity

CS I/O PORT: Interface with telecommunications peripherals manufactured by Campbell Scientific.

SDI-12: Digital control ports C1, C3, C5, and C7 are individually configured and meet SDI-12 Standard v 1.3 for datalogger mode. Up to 10 SDI-12 sensors are supported per port.

PERIPHERAL PORT: 40-pin interface for attaching

CompactFlash or Ethernet peripherals

PROTOCOLS SUPPORTED: PakBus, AES-128 Encrypted

PakBus, Modbus, DNP3, FTP, HTTP, XML, HTML, POP3,

SMTP, Telnet, NTCIP, NTR, Web API, SDI-12, SDM.

SYSTEM

PROCESSOR: Renesas H8S 2322 (16-bit CPU with 32-bit internal core running at 7.3 MHz)

MEMORY: 2 MB of flash for operating system; 4 MB of battery-backed SRAM for CPU usage, program storage and final data storage.

REAL-TIME CLOCK ACCURACY: ±3 min. per year.

Correction via GPS optional.

REAL-TIME CLOCK RESOLUTION: 10 ms

SYSTEM POWER REQUIREMENTS

VOLTAGE: 9.6 to 16 Vdc

INTERNAL BATTERIES: 1200 mAh lithium battery for clock and

SRAM backup that typically provides three years of backup

EXTERNAL BATTERIES: Optional 12 Vdc nominal alkaline

and rechargeable available. Power connection is reverse

polarity protected.

TYPICAL CURRENT DRAIN at 12 Vdc:

Sleep Mode: 0.7 mA typical; 0.9 mA maximum

1 Hz Sample Rate (1 fast SE meas.): 1 mA

100 Hz Sample Rate (1 fast SE meas.): 16.2 mA

100 Hz Sample Rate (1 fast SE meas. w/RS-232

communication): 28 mA

Active external keyboard display adds 7 mA (100 mA

with backlight on).

PHYSICAL

DIMENSIONS: 23.9 x 10.2 x 6.1 cm (9.4 x 4 x 2.4 in);

additional clearance required for cables and leads.

MASS/WEIGHT: 1 kg / 2.1 lb

WARRANTY

3 years against defects in materials and workmanship.



Campbell Scientific, Inc. | 815 W 1800 N | Logan, UT 84321-1784 | (435) 227-9000 | www.campbellsci.com
 USA | AUSTRALIA | BRAZIL | CANADA | CHINA | COSTA RICA | ENGLAND | FRANCE | GERMANY | SOUTH AFRICA | SPAIN

© 2004, 2014
 Campbell Scientific, Inc.
 January 22, 2014 5:04 PM