

Technical University of Denmark



## Modifications to the current WAsP engine for Online WAsP

**Pena Diaz, Alfredo; Troen, Ib; Bechmann, Andreas; Kelly, Mark C.; Rathmann, Ole Steen; Heathfield, D.**

*Publication date:*  
2014

*Document Version*  
Publisher's PDF, also known as Version of record

[Link back to DTU Orbit](#)

*Citation (APA):*  
Peña, A., Troen, I., Bechmann, A., Kelly, M. C., Rathmann, O. S., & Heathfield, D. (2014). Modifications to the current WAsP engine for Online WAsP. DTU Wind Energy. (DTU Wind Energy I; No. 0206(EN)).

## DTU Library

Technical Information Center of Denmark

---

### General rights

Copyright and moral rights for the publications made accessible in the public portal are retained by the authors and/or other copyright owners and it is a condition of accessing publications that users recognise and abide by the legal requirements associated with these rights.

- Users may download and print one copy of any publication from the public portal for the purpose of private study or research.
- You may not further distribute the material or use it for any profit-making activity or commercial gain
- You may freely distribute the URL identifying the publication in the public portal

If you believe that this document breaches copyright please contact us providing details, and we will remove access to the work immediately and investigate your claim.

# Modifications to the current WAsP engine for Online WAsP

DTU Wind Energy  
I-Report

Alfredo Peña, Ib Troen, Andreas Bechmann,  
Mark Kelly, Ole Rathmann and Duncan Heathfield

DTU Wind Energy Report-I-0206(EN)  
April 2014

DTU Wind Energy  
Department of Wind Energy

---



# Modifications to the current WAsP engine for Online WAsP

Alfredo Peña, Ib Troen, Andreas Bechmann, Mark Kelly, Ole Rathmann, and Duncan Heathfield

DTU Wind Energy  
Department of Wind Energy

---



DTU Wind Energy, Risø Campus,  
Technical University of Denmark, Roskilde, Denmark

April 2014

**Author:** Alfredo Peña, Ib Troen, Andreas Bechmann, Mark Kelly, Ole Rathmann, and Duncan Heathfield  
**Title:** Modifications to the current WAsP engine for Online WAsP  
**Department:** DTU Wind Energy

**DTU Wind Energy**  
**Report-I-0206(EN)**  
**April 2, 2014**

**Abstract (max. 2000 char)**

This report documents the work performed in work package 3 of the Online WAsP EUDP project (Online WAsP for Small Wind Turbines). Specifically it is deliverable D3.1 "Report on modifications required to update current WAsP calculation engine".

**ISSN:**  
**ISBN:**

**Contract no:**

**Project no:**  
1130612-01

**Sponsorship:**

**Cover:**

**Pages:** 19  
**Tables:** 0  
**Figures:** 12  
**References:** 15

Technical University  
of Denmark  
Frederiksborgvej 399  
4000 Roskilde  
Denmark  
Tel. +4546775024  
[bcar@dtu.dk](mailto:bcar@dtu.dk)  
[www.vindenergi.dk](http://www.vindenergi.dk)

# Contents

	<b>Page</b>
<b>1 Introduction</b>	<b>5</b>
<b>2 Obstacle model</b>	<b>6</b>
2.1 Evaluation of the obstacle model . . . . .	6
2.2 General description of obstacles . . . . .	7
2.2.1 Exploration and explanation . . . . .	8
2.2.2 Reconciliation and adaptation . . . . .	9
<b>3 Forest, forest edges and other local effects</b>	<b>10</b>
3.1 Generalized map format . . . . .	10
3.2 Roughness lengths and displacement heights . . . . .	10
3.3 Forest edges . . . . .	11
<b>4 Uncertainty</b>	<b>12</b>
4.1 Estimation and improvement . . . . .	12
<b>5 Low wind speeds</b>	<b>14</b>
<b>6 Summary</b>	<b>18</b>
<b>References</b>	<b>19</b>

# 1 Introduction

In work package (WP) 3 of the Online WAsP EUPD project, we plan to:

1. identify the shortcomings of the current WAsP engine for small and medium wind turbines (WTs)
2. develop/adapt the current WAsP engine for better estimation of annual energy production (AEP) of small and medium WTs.

This report documents on the results of point 1 above.

The Wind Atlas Analysis and Application Program (WAsP) is the worldwide standard for AEP and wind resource assessment calculations (Mortensen et al., 2007). Although it is composed by more models, the three main ones are those treating orography, roughness, and obstacles. The effects of these three models are nearly independent in the current version of WAsP (v11) and are used to both generalize wind climates<sup>1</sup> from observations of wind speed and direction from a particular site and height (the observed wind climate or OWC), and predict wind climates at a particular site and height (the predicted wind climate or PWC). It is well-known and has been reported that these models are limited to a range of conditions and that they can produce misleading results when used beyond their operational envelope (Dellwik et al., 2006; Mortensen et al., 2007).

Some of the models' limitations especially affect small and medium size WTs, as these are often deployed near obstacles, such as houses or buildings, or close to or within forest areas. We therefore identify the related models, i.e. the obstacle and roughness model as key elements for improving AEP assessments of WTs and in our case those for small and medium-size machines.

Further, we envisioned that a methodology to estimate uncertainty in AEP calculations will be developed for Online WAsP and WAsP as this is not yet available in any of the WAsP family of programs. As small and medium size turbines are not placed in the windiest places and are close to the ground (have limited hub height), the WAsP assumptions related to the wind speed distributions at this type of sites and heights might be not very realistic. The last section documents an example of the explorations we have made related to this issue.

---

<sup>1</sup>In WAsP, wind climate is the information related to frequency distribution of the wind speed in different sectors

## 2 Obstacle model

Currently, WAsP includes an obstacle model (hereon referred to as WAsP-shelter) in which the shelter behind an obstacle is estimated. The shelter is defined as the relative decrease in wind speed caused by the obstacle. The shelter depends on the horizontal and vertical distances from the obstacle to the specific site and the height, length, and porosity of the obstacle. WAsP-shelter is based on the 2D fence expressions in Perera (1981) (see Fig. 1). As such expressions concern obstacles with 'infinite' lateral dimensions, WAsP-shelter decreases the wind speed reduction of 'finite' obstacles due to lateral mixing of wakes. WAsP-shelter is described in detail in Troen and Petersen (1989), and the expressions therein include the effect of porosity.

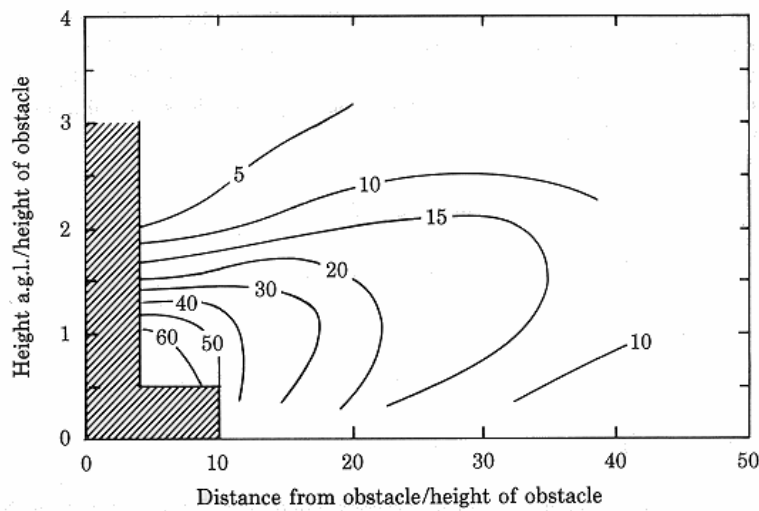

Figure 1: Schematic drawing of the wind speed reductions in percentage based on the shelter expressions by Perera (1981) for an infinitely long 2D obstacle of zero porosity

WAsP-shelter may not yield realistic results close to the obstacle (hatched area in Fig. 1), since it is based on measurements of "far-field" wakes. In addition it assumes an areal drag coefficient of unity, thus ignoring possible drag reduction due to obstacles being more aerodynamic. Taylor and Salmon (1993) introduced reduced drag coefficients for typical 3D buildings based on wind tunnel measurements and found that this significantly reduced the effective sheltering. We will investigate this issue with a view of improving the shelter model using available experimental data and CFD simulations.

### 2.1 Evaluation of the obstacle model

We want to evaluate WAsP-shelter by comparing its results with those from computational fluid dynamics (CFD) simulations of a modeled obstacle. Due to the 'simplicity' of WAsP-shelter, such an evaluation needs to be performed using a simple CFD obstacle model. The main idea of the evaluation is to help us finding its strengths and weaknesses.

To make a CFD obstacle model, we take advantage of the ability of EllipSys (Sørensen, 2003) to use block structured grids (e.g. blocks of  $32^3$  grid points); we make a rectangular domain of  $8 \times 14 \times 4$  blocks/cubes surrounded by a polar domain. Single cubes in the inner rectangular domain can be set to be either porous or solid. By setting several solid cubes rather complex obstacles can be generated in a flexible manner. By changing the Jensen number (relation between block height and roughness) the simulation results will change. We keep the block sizes constant but change the roughness between simulations thereby effectively changing the scale of the buildings. The surrounding polar domain allows us to

simulate different wind directions in a similar manner as WAsP-shelter.

The first cases we simulate should validate the CFD model. To do this we need to find experimental data such as those related to the cube in a wind tunnel by Castro and Robins (1977). We simulated this case before (Sørensen, 2003) as illustrated in Fig. 2.

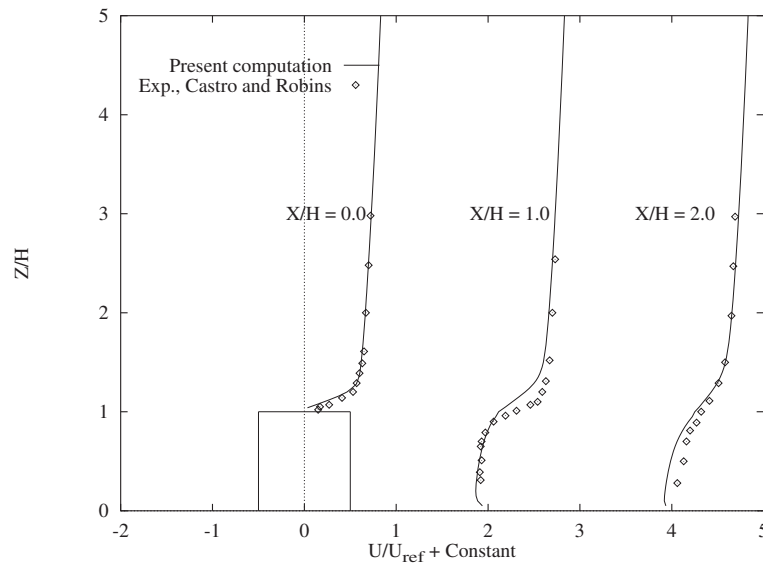

Figure 2: A comparison of the computed velocity profile at different values of  $x/H$ , the ratio of the downstream distance to the height of the cube, with the measurements from Castro and Robins (1977). Figure from Sørensen (2003).

The figure shows the measured and CFD simulated wind profiles on top of a cube-shaped obstacle and at two downstream positions. Although the match is not perfect, it illustrates that CFD can be used to examine the complicated flow near simple obstacles. This is useful when no measurements are available.

When the results from the CFD become trustable, we can generate a variety of obstacles in WAsP and CFD and compare their results. We have already performed few building simulations (Beller, 2011). Some examples of the possible shapes and arrangements we could make are shown in Fig. 3. CFD results on some of these arrangements are shown in Fig. 4. The figure illustrates the complex flow patterns that CFD predicts close to the building; WAsP-shelter is designed to model far field behavior. CFD can be used to evaluate the far field distance for WAsP-shelter to give reliable results.

We might have the opportunity to evaluate WAsP-shelter and the CFD obstacle model with measurements from 'simplified' experiments planned in another EUDP project (*IEA Wind Task 27 – Mærkning af små vindmøller*), where the effect of obstacles such as trees and houses on small wind turbines will be addressed.

## 2.2 General description of obstacles

Obstacles are considered in WAsP as 'boxes' with a rectangular cross-section and footprint. Each obstacle is specified by its position relative to a specific site (either a reference or a turbine site) in a polar coordinate system. Its dimensions need to be provided as well as the porosity. Figure 5 illustrates how to specify an obstacle in WAsP.

We would like to implement some extensions to the general description of obstacles in WAsP. This implementation has two phases: 1) Exploration and explanation and 2) Reconciliation and adaptation.



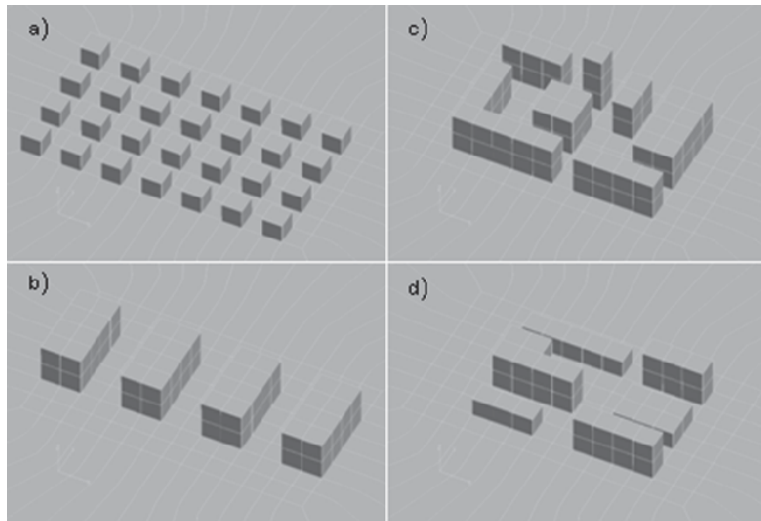

Figure 3: A number of 'building' configurations possible in CFD. Figure from Beller (2011)

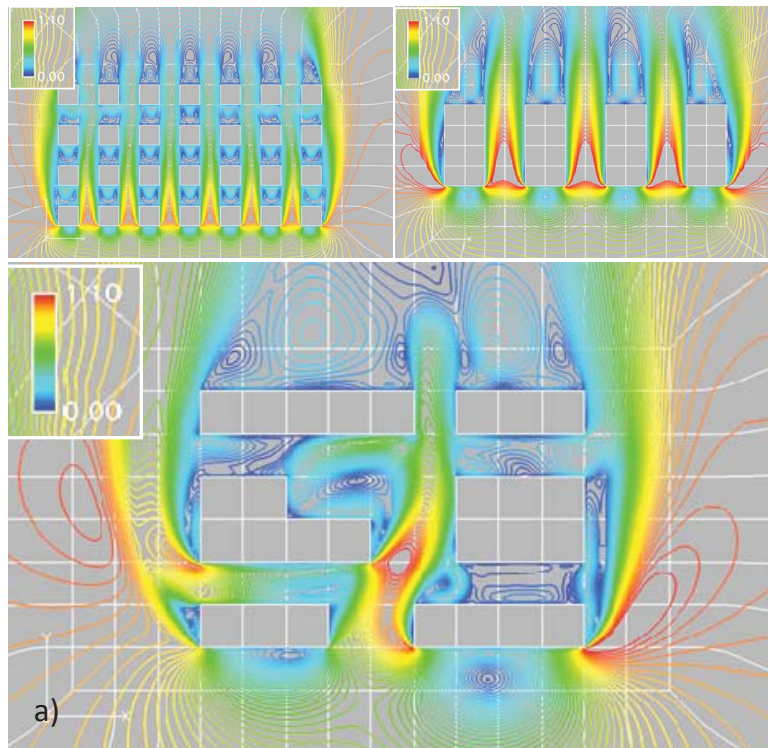

Figure 4: CFD results of a number of configurations illustrated in Fig. 3. Figure from Beller (2011)

### 2.2.1 Exploration and explanation

There are two implementations of the obstacle model in the family of WASP programs.<sup>2</sup> The WASP engineering program uses an obstacle model (hereon referred to as WEng-shelter) that follows to a large extent WASP-shelter. It is also based on the formulations by Perera (1981) with some physical reasoning and additions (Astrup and Larsen, 1999).

We will look at both WASP-shelter and WEng-shelter and try to find out whether it is advantageous to update WASP-shelter based on WEng-shelter. Part of the work will be dedicated to properly document the WASP-shelter model.

<sup>2</sup><http://www.wasp.dk/Products-og-services>

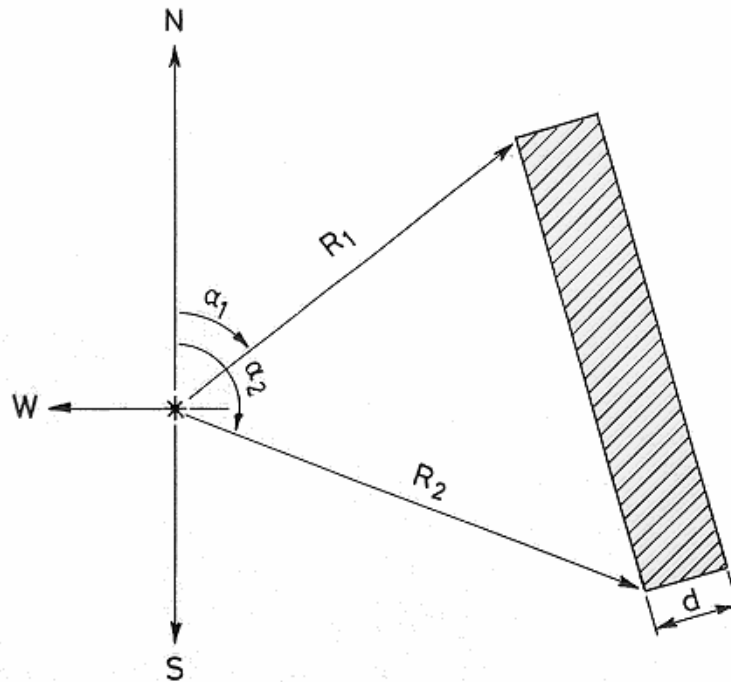

Figure 5: Illustrative plot on the specification of obstacles in WAsP. The user must input the angle from North to the obstacle's first corner ( $\alpha_1$ ) and its radial distance ( $R_1$ ), the angle from North to the obstacle's second corner ( $\alpha_2$ ) and its radial distance ( $R_2$ ), the height of the obstacle (not shown), the depth of the obstacle ( $d$ ) and the porosity ( $P$ ; a fraction in the range 0–1)

### 2.2.2 Reconciliation and adaptation

After the work described in Sec. 2.2.1, we would find out whether we can unify the obstacle model in WAsP, WAsP Engineering, and thus in Online WAsP. Both WAsP-shelter and WEng-shelter require obstacles to be represented as rectangles for input (either as in site-relative polar coordinates or in Cartesian coordinates). Now that so much data are derived automatically from maps, a constraint will be to describe the horizontal extend of an obstacle by any arbitrary shape.

In particular, this prevents the possibility of automatic transition between roughness model and obstacle model treatment of a terrain feature because the data are 'locked' into separate input file representations. For example, if a cluster of buildings was a feature in the map, then it could automatically be extracted and represented as an obstacle if a site was nearby, or rendered as a roughness feature at greater distances. We will look for alternatives to represent obstacles and try to develop methodologies to make user obstacle inputs even more straightforward.

We will develop a convenient test rig program, which includes and isolates WAsP-shelter and WEng-shelter allowing various metric coordinate systems. This will provide us with a direct tool to benchmark the models with the findings from wind tunnel and numerical simulations from the literature and to the rather possible 'real' test cases which will be performed in the *IEA Wind Task 27 – Mærkning af små vindmøller* EUDP project.

### 3 Forest, forest edges and other local effects

In WAsP the effect of varying surface roughness is taken into account in the IBL-model (Internal Boundary Layers). This has been found to perform well over relatively smooth surfaces (Troen and Petersen, 1989; Sempreviva et al., 1990; Weng et al., 2010). Over rougher areas, such as forests and cities, and near such areas, a number of physical mechanisms, not presently included in the IBL-model, become important. Firstly, the current IBL model assumes that the growth of the IBL starts out essentially at a height equal to the (max.) roughness length, thus neglecting flow **displacement**. Secondly, it aggregates surface roughness areas using a simple areal averaging, thus neglecting the effect of **patchiness** (Hasager and Jensen, 1999). It appears to be possible, still within a simple IBL model framework, to improve the model by taking these effects into account. Also, it may be possible to incorporate a simple treatment of the more local effects of **forest edges** (Dellwik et al., 2014) as illustrated in Fig. 6.

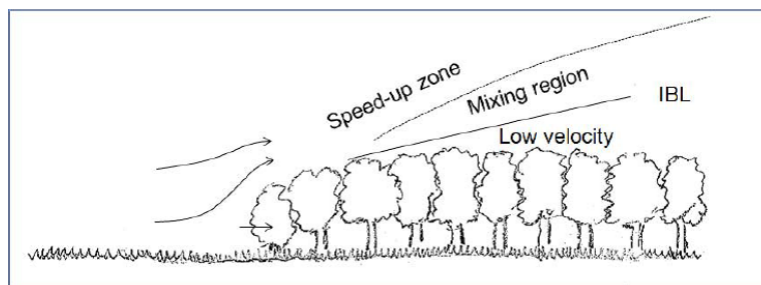

*Figure 6:* A schematic picture of flow downstream from a forest edge. The elevated IBL development is evident. The wind profile downwind over the forest is “lifted” (displacement height). For flow in the opposite direction, from forest to clearing/open land the IBL will start out as a mixed region with a height comparable to the displacement height. Illustration by Ebba Dellwik, DTU Wind Energy

#### 3.1 Generalized map format

In order to be able to improve the IBL model in WAsP, more terrain information is needed than what is presently available in the WAsP map format, which contains only terrain height contours and surface roughness change contours. A generalized format has been developed and this will be used as far as possible for this project. The format allows better and more flexible use of existing databases of land-use and land cover. The format is similar to the classical map format, but instead of having roughness change contour lines it contains contour lines depicting land-use/land-cover changes. A “translation-table” (specific for each land classification system) is used to translate these land types into the needed physical parameters of the surface (see Fig. 7). Of special concern in this project is the estimation of surface roughnesses, displacement heights (specially over rough areas such as forests and for relatively low (hub) heights).

#### 3.2 Roughness lengths and displacement heights

The roughness above a homogeneous forest depends on a number of parameters, most importantly the height of the trees and their type (to give an effective aerodynamic cross section) and of their mutual separation. Also the effective displacement height of the vertical wind speed profile depends on these parameters. An important improvement of the IBL model

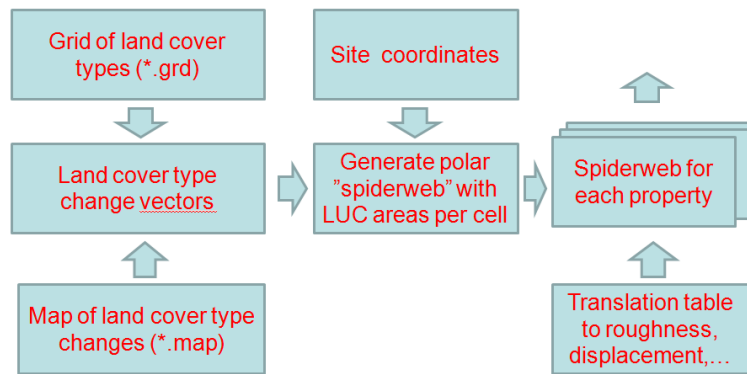

Figure 7: Block diagram of the intended use of the new map format in an improved surface analysis in WAsP and Online WAsP. Information on land-cover/land-use (LUC) types in either vector or grid format from e.g. existing databases are transformed to polar “spider-webs” centered at the point of interest and using translation tables to derive e.g. surface roughness and displacement heights. With sufficient detail (e.g. tree heights and distances) and spatial resolution of the input map data sufficient information on patchiness and forest edges may be available

would be to model these dependencies based on the use of the generalized map format.

In the more common case, where the forest is not homogeneous, but divided into stands of different heights (ages) and types, and when the forest is interspersed with clearings, the patchiness can have a considerable effect on the effective surface roughness (Hasager and Jensen, 1999). In addition, the forest edges act as additional windbreaks further adding to the surface drag and thus to the effective roughness length. None of these effects are presently included in the IBL model. We intent to explore the possibility of including these effects in an improved IBL model for Online WAsP.

### 3.3 Forest edges

Near forest edges, at heights comparable to the tree heights and at horizontal distances up to some tens of tree heights, local sheltering should be expected, and in addition the behavior of the internal boundary layers generated by the edges may be affected by the step change (Dellwik et al., 2014). Neither of these mechanisms are presently taken into account by the WAsP model, and modifications will be investigated to improve the model for Online WAsP.

## 4 Uncertainty

There are a number of mechanisms and aspects of the WAsP model and its 'typical' use, which contribute to the overall uncertainty (i.e. for large turbines with hub heights above 20 m). For the 'Online WAsP' application, intended for smaller turbines and lower hub heights, there are additional sources of uncertainty, and the relative contributions of the typical uncertainties are also modified.

Most broadly speaking, the uncertainties can be divided into those attributable to observations and modeling. Within observations, one may identify measurement uncertainties for typical cup-anemometer and wind vane instrumentation on the order of 5% or less, as shown in the EWEA CREYAP exercise,<sup>3</sup> which is expected to be used for most small-turbine (low-height) estimates. One may also consider long-term corrections to the wind measurements as part of the modeling, though in the current project this uncertainty is effectively replaced by the uncertainty due to the use and application of global wind atlas data to a given site. The latter may be expected to be the prevailing contributor to the total uncertainty in many cases, since global data (of 40 km resolution or coarser), which are dominated by upper-level pressure gradients, must be interpolated to a given site and height; even high-resolution mesoscale predictions produce errors in wind speed of 5% or more, and thus we can expect small-turbine AEP uncertainties in this project well beyond 10% at most sites. This is also consistent with the  $\approx 5\%$  uncertainty found due to horizontal extrapolation in the EWEA CREYAP exercise, where the extrapolation distances were much smaller.

The flow modeling can also dominate the uncertainty, particularly in complex terrain and even more so when there are sharp and complicated features close to the site of interest. For example, Troen et al. (2014) found prediction errors in complex terrain of  $\approx 10 - 40\%$  when using the IBZ flow model for horizontal extrapolation distances beyond 10 km. This uncertainty was found to be largest for the lowest prediction and measurement heights, as would be expected due to the greater influence of terrain (e.g. more nonlinear effects and flow separation) nearer to the surface. There is also uncertainty inherent in the roughness and terrain description, as well as the roughness modeling; this tends to be minor compared to terrain complexity, but can be significant for more modest terrain such as coastlines.

A final major (and potentially predominant) source of uncertainty is that due to modeling near-field obstacle effects, such as those from nearby buildings, which involve complicated flow fields caused by complex and/or sharp-featured geometry (i.e. buildings have corners). The current Perera-type parametrization is not intended for resolving sharp near-field features or severe (or intermittent) flow separation (Taylor and Salmon, 1993), resulting in the over-sheltering bias mentioned in Sec. 2.

### 4.1 Estimation and improvement

Given that there are a number of uncertainty sources involved in the use of both WAsP and global-scale non-local wind data in small-turbine environments, and that these are generally not simply correlated nor independent of each other, it appears reasonable to examine the largest factors independently, to estimate upper-bounds on each. Time and resources permitting, the interaction of these may be studied in order to improve overall estimates. The major uncertainties are the use of large-scale (e.g. global) data to drive WAsP, the use of WAsP's IBZ flow model in complex terrain, and the effects of nearby obstacles.

The latter will be examined through validation as outlined in Sec. 2. The uncertainty due to terrain complexity follows from the earlier analysis of Troen et al. (2014), though it can be augmented via consideration of a larger number of low-height cases. The uncertainty involved in the use of large-scale forcing follows from work with the Global Wind Atlas,<sup>4</sup>

<sup>3</sup><http://www.ewea.org/events/workshops/past-workshops/wind-resource-assessment/comparison-of-resource-and-energy-yield-assessment-procedures>

<sup>4</sup><http://globalatlas.irena.org/>

where a number of sites/cases must be considered. This may include re-examination of the earlier sites in complex terrain, as well as possibly a number of low-height stations in the South African Wind Atlas project<sup>5</sup> (many of which involve obstacles), as well as simple 10 m stations in various regions.

---

<sup>5</sup><http://www.wasaproject.info>

## 5 Low wind speeds

There has been some concern about the way WAsP treats wind climates, when these are characterized with a high frequency of low wind speeds or calms, as wind speed distributions from such climates are not well-fitted by the Weibull distribution, which is used in WAsP for AEP estimations. The concern is that, as a result, the WAsP-estimated AEP is much higher than the real AEP.

As a first attempt to find out whether WAsP has a problem with 'low wind' speed climates, we used high-quality 10-min averaged data from the Høvsøre meteorological mast (Peña, 2009) from the cup anemometer at 2 m and the vane at 10 m (Høvsøre is a rather windy site so only at 2-m we find a good number of low wind speed data) corresponding to the years 2005–2013 (more than 467000 10-min records). Figure 8 illustrates the wind rose correspondent to these data, where it is observed that particularly for easterly winds, the wind speed bins 0–2 and 2–4  $\text{m s}^{-1}$  are very popular; these are wind speed ranges where turbines do not normally operate.

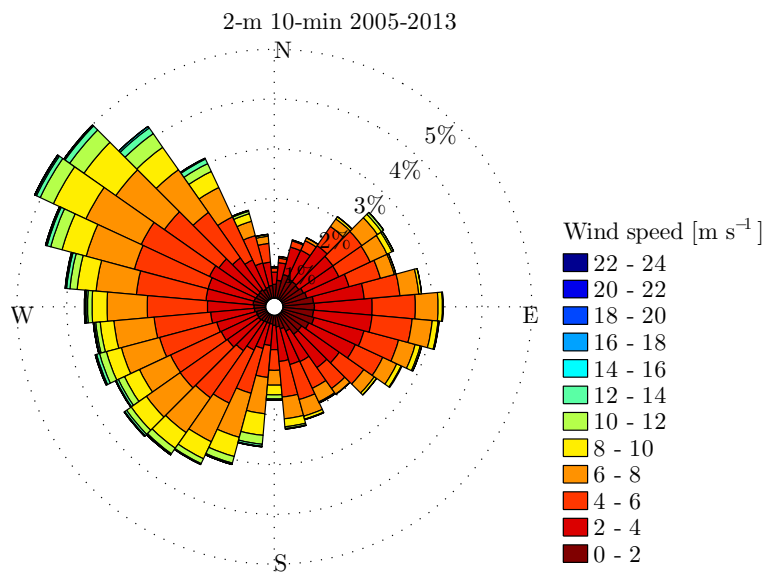

Figure 8: The wind climate at Høvsøre met mast at 2 m from 2005–2013

An OWC was created based on the data using the WAsP Climate Analyst v2.0. We used 12 sectors and wind speed bins of  $1 \text{ m s}^{-1}$  for the OWC. As seen in Fig. 9, Weibull A and k parameters are derived from each sector in the OWC.

We wanted to see whether a time series-based AEP, which will make use of the long time series, is similar to that based on the distributions as performed in WAsP. However, WAsP does not derive the AEP based on the OWC but on the PWC at the turbine site, which is also a distribution-based climate. In an 'ideal' scenario, the PWC and the OWC will be the same if we predict the wind climate at the same site and height where the OWC comes from. However, due to the numerical approximations within the up- and down-methodology for wind climate extrapolation in WAsP, there is a slight difference between the OWC and PWC as shown in Fig. 10.

The frequencies on each sector are the same between the OWC and PWC but the Weibull A and k parameters slightly differ. First we tested whether we can find in a Matlab script the same AEP obtained in WAsP based on the Weibull parameters of the PWC. By doing so, we become confident on our Matlab-based derivation of the distribution-based AEP. We will then estimate the distribution-based AEP from the OWC using the Matlab script and compare it with the time series-based AEP also derived in Matlab.

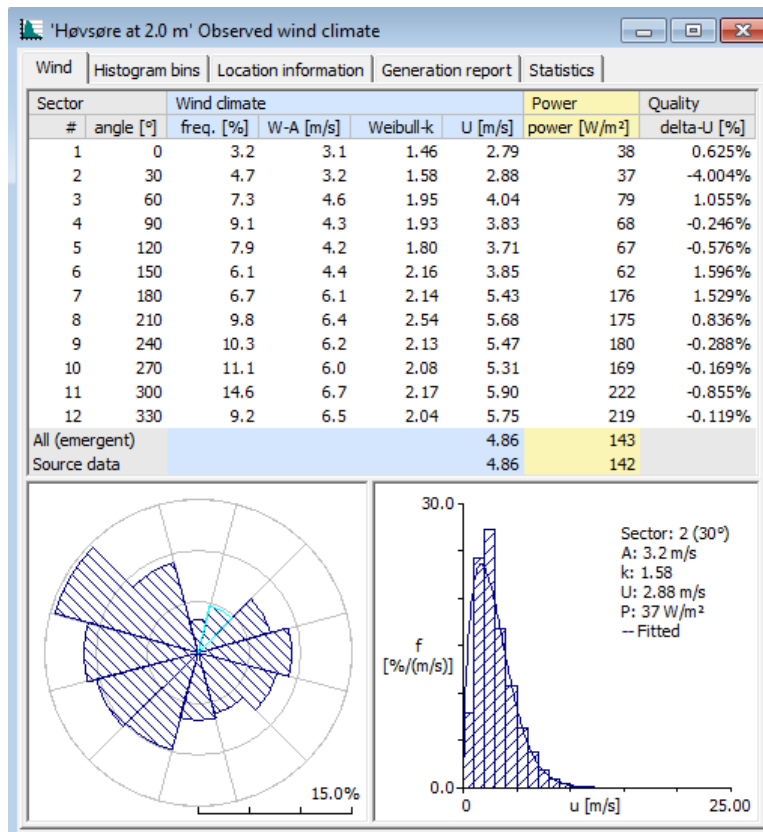

Figure 9: The OWC from the data in Fig. 8

We choose the Bonus 300 kW MkIII wind turbine to perform the computations (see Fig. 11). As shown in Fig. 10, WAsP's (v.11) AEP is 436.539 MW h. Using our Matlab-script, we find a distribution-based AEP of 435.967 MW h. Due to the very good agreement in AEPs, we can use the Matlab-script to estimate the distribution-based AEP of the OWC. This results in 444.719 MW h, an approx. 2% higher AEP than that derived with the PWC Weibull parameters. Using the time series, we estimate from our Matlab script an AEP of 436.583 MW h, i.e. by fitting a Weibull distribution per sector, WAsP probably overestimates 1.77% the AEP for this particular wind climate. Interestingly, when using histograms with  $1 \text{ m s}^{-1}$  bins for 12 sectors, the estimated AEP by our Matlab script is 450.630 MW h.

This of course does not mean that WAsP does a good job for all types of climates but it gives us an indication that low wind speed climates does not seem to be a problem for WAsP. This is mostly due to the way WAsP fits the Weibull distribution to the histogram of wind speeds since the power density is the target when fitting and not the mean wind speed.

Another example was performed on a time series from the Cagliari region in Italy. The wind data are unfortunately not of high-quality. Figure 12 shows the OWC for the site, where it is clear that the wind speed histogram is not well fitted by the Weibull (even for the all-sector distribution). Using the Bonus wind turbine power curve, the distribution-based AEP is 352.525 MW h, whereas the time series-based AEP is 335.075 MW h, i.e. less than 5% difference in AEP estimations.



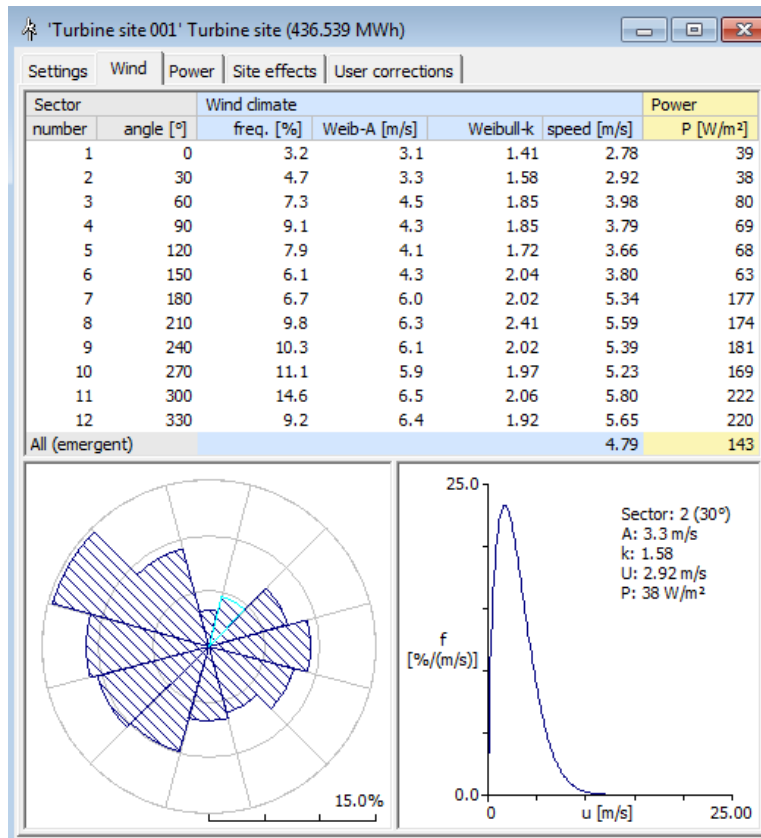

Figure 10: The PWC from the data in Fig. 8

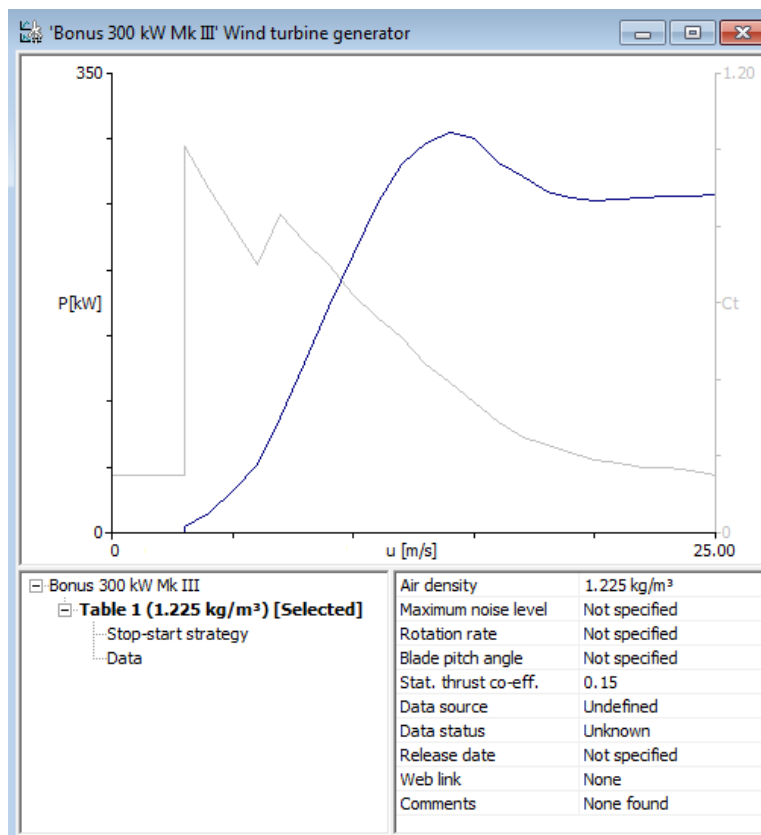

Figure 11: Power and thrust curves for the Bonus 300 kW MkIII wind turbine

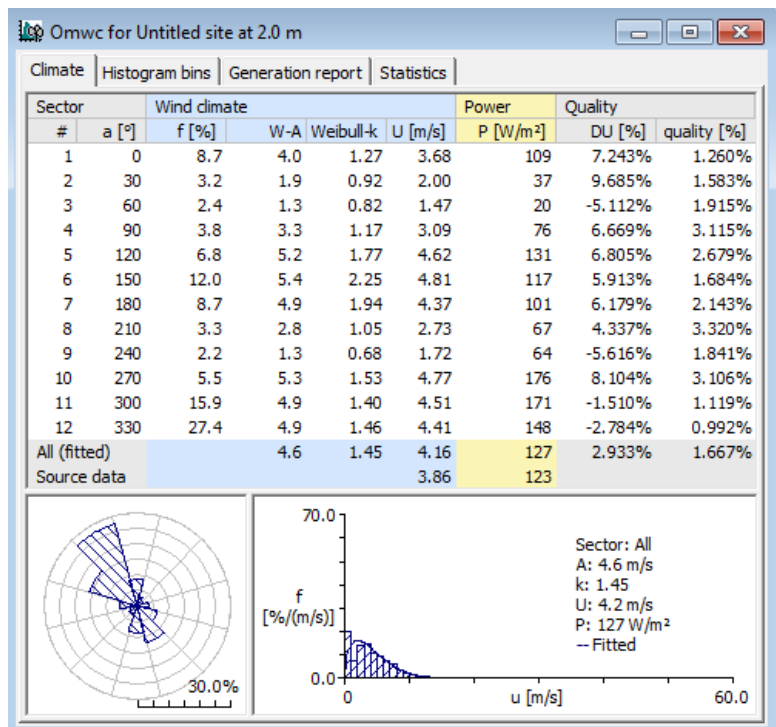

Figure 12: The OWC from a synoptic station in the Cagliari region

## 6 Summary

For Online WAsP, we envisioned a evaluation and possible improvement of the obstacle model in WAsP as this probably overestimates the wind speed reduction due to shelter and produce too uncertain results in the region close to the obstacle. We suggest this evaluation can be made by comparison with obstacles simulated in CFD and there is the possibility to include measurements from wind tunnels and ongoing projects where the flow around real obstacles will be measured. The improvements will be probably more related to the way the user inputs obstacles into the model rather than the model itself.

Online WAsP will benefit from the current improvements of the WAsP IBL model for better treatment of forest, forest edges and other local effects. The map format will be updated so that existing databases of land-use and land cover can be used in WAsP. Of special concern will be given to the specification of roughness length and displacement heights, and the inclusion of effects such as forest patchiness and forest edges.

The mechanisms contributing to the uncertainty of AEP estimates using Online WAsP will be investigated. These include the global wind atlas-related uncertainty as source of wind data, the IBZ model for modeling both orography and roughness changes, and that derived from applying WAsP-shelter.

We explored the ability of WAsP to predict AEPs for a wind climate with a high frequency of low wind speeds. WAsP reproduced very well the AEP when compared to a time series-derived AEP but this was mainly performed with a wind climate, where the dominant winds are well Weibull-distributed. We expect to run more examples with other wind climates where the wind speed histograms are not that well represented by the Weibull distribution.

# References

- Astrup, P. and S. E. Larsen, 1999: Wasp engineering flow model for wind over land and sea. Tech. Rep. Risø-R-1107(EN), Risø National Laboratory, 24 pp.
- Beller, C., 2011: Urban wind energy. Tech. Rep. Risø-PhD-089(EN), Risø National Laboratory for Sustainable Energy, 164 pp.
- Castro, I. P. and A. G. Robins, 1977: The flow around a surface-mounted cube in uniform and turbulent streams. *J. Fluid Mech.*, **79**, 307–335.
- Dellwik, E., F. Bingöl, and J. Mann, 2014: Flow distortion at a dense forest edge. *Quart. J. Roy. Meteorol. Soc.*, **140**, 676–686.
- Dellwik, E., L. Landberg, and N. O. Jensen, 2006: Wasp in the forest. *Wind Energ.*, **9**, 211–218.
- Hasager, C. B. and N. O. Jensen, 1999: Surface-flux aggregation in heterogenous terrain. *Q. J. R. Meteorol. Soc.*, **125**, 2075–2102.
- Mortensen, N. G., D. N. Heathfield, L. Myllerup, L. Landberg, and O. Rathmann, 2007: Getting started with WAsP 9. Tech. Rep. Risø-I-2571(EN), Risø National Laboratory, Roskilde, Denmark, <http://www.wasp.dk/Download/DownloadFiles/General/GettingStartedWithWASP9.pdf>.
- Peña, A., 2009: Sensing the wind profile. Tech. Rep. Risø-PhD-45(EN), Risø DTU, 80 pp.
- Perera, M. D. A. E. S., 1981: Shelter behind two-dimensional solid and porous fences. *J. Wind Eng. Ind. Aerodyn.*, **8**, 93–104.
- Sempreviva, A. M., S. E. Larsen, N. G. Mortensen, and I. Troen, 1990: Response of neutral boundary layers to changes of roughness. *Boundary-Layer Meteorol.*, **50**, 205–225.
- Sørensen, N. N., 2003: General purpose flow solver applied to flow over hills. Tech. Rep. Risø-R-827(EN), Risø National Laboratory, 154 pp.
- Taylor, P. A. and J. R. Salmon, 1993: A model for the correction of surface wind data for sheltering by upwind obstacles. *J. Appl. Meteorol.*, **32**, 1683–1694.
- Troen, I., A. Bechmann, M. C. Kelly, N. N. Sørensen, P.-E. Réthoré, D. Cavar, and H. E. Jørgensen, 2014: Complex terrain wind resource estimation with the wind-atlas method: Prediction errors using linearized and nonlinear CFD micro-scale models. *Proceedings of the European Wind Energy Association Conference & Exhibition*, Barcelona.
- Troen, I. and E. L. Petersen, 1989: European Wind Atlas. Tech. rep., Risø National Laboratory, Roskilde, Denmark, 656 pp.
- Weng, W., P. A. Taylor, and J. R. Salmon, 2010: A 2-D numerical model of boundary-layer flow over single and multiple surface condition changes. *J. Wind Eng. Ind. Aerodyn.*, **98**, 121–132.

---

**DTU Wind Energy**  
**Technical University of Denmark**

Frederiksborgvej 399  
4000 Roskilde  
Denmark  
Phone +45 4677 5024

[www.vindenergi.dtu.dk](http://www.vindenergi.dtu.dk)