

Technical University of Denmark



Computer aided simulation for developing a simple model to predict cooling of packaged foods

Christensen, Martin Gram; Feyissa, Aberham Hailu; Adler-Nissen, Jens

Publication date:
2011

Document Version
Publisher's PDF, also known as Version of record

[Link back to DTU Orbit](#)

Citation (APA):
Christensen, M. G., Feyissa, A. H., & Adler-Nissen, J. (2011). Computer aided simulation for developing a simple model to predict cooling of packaged foods. Paper presented at 11th International Congress on Engineering and Food, Athens, Greece.

DTU Library

Technical Information Center of Denmark

General rights

Copyright and moral rights for the publications made accessible in the public portal are retained by the authors and/or other copyright owners and it is a condition of accessing publications that users recognise and abide by the legal requirements associated with these rights.

- Users may download and print one copy of any publication from the public portal for the purpose of private study or research.
- You may not further distribute the material or use it for any profit-making activity or commercial gain
- You may freely distribute the URL identifying the publication in the public portal

If you believe that this document breaches copyright please contact us providing details, and we will remove access to the work immediately and investigate your claim.

Computer aided simulation for developing a simple model to predict cooling of packaged foods

Martin Gram Christensen^a, Aberham Heilu Fayissa^a, Jens Adler-Nissen^a

^a National Food Institute, DTU, Lyngby, Denmark (mgch@food.dtu.dk)

ABSTRACT

A new equation to predict equilibrium temperatures for cooling operations of packaged foods has been deduced from the traditional 1st order solution to Fourier's heat transfer equations. The equation is analytical in form and only requires measurable parameters, in form of area vs. volume ratio (A/V), thermo-physical properties calculated from the recipe, and the heat transfer coefficients measured in the equipment. The equation is based on an overall Biot number. The simple deduced model was tested and validated with experimental and simulated setups. Simulations have been performed using COMSOL Multiphysics, commercially available software, to test the new equation. Additionally, an experiment with all boundary conditions known, and the three dimensional coordinates of the position of six thermocouples were conducted. The COMSOL simulation showed very good conformity with experimental results matching all individual thermocouples. Simulations are used as a validation tool for cooling predictions. This was done by comparing the simulated equilibrium temperature with the calculated using the new equation. The simulations are able to evaluate cooling situations in the industry where experiments are too laborious or impossible to conduct. The deduced equation was tested for irregular geometries, unequal heat transfer and headspace restrictions. The new equation predicted equilibrium temperature curves of the simulated cooling with a low error (1.5°C for Fourier numbers below 0.3) and good precision at the target temperature (error below 0.5°C for Fourier numbers above 0.3).

Keywords: Cooling; Finite Element Method; Irregular geometry; Heat Transfer; Modelling

INTRODUCTION

Cooling operations are important unit operations in the food industry. Often, it is a big challenge to find the appropriate cooling time because the optimal set-point is to achieve the correct equilibrium temperature in the product before it is conveyed to the cold storage. As the product eventually will obtain the same temperature in the cold storage it is economically advantageous only to cool until the cold storage equilibrium temperature is met. However, it is difficult to conduct experiments for measuring the equilibrium temperature over time, especially in industrial setups. This necessitates fast calculations to manage prediction of the equilibrium temperature during daily operation management. So far, simple equations have only been developed to handle calculations of the equilibrium temperature of simple geometries for cooling processes where the solutions suggested by Pflug *et.al* [1] can be used. The scope of this project is to derive such models by using finite element modelling (FEM) in COMSOL Multiphysics to conduct *in silico* experiments for the validation of the models. In this paper the first developed model based on A/V (area to volume) ratio and an overall Biot-number is validated. The models must be analytical for implementation in commercial software, easy to use, and still provide more precision than the traditional 1st order approximations of Fourier's equations for $Fo > 0.3$ and simple geometries.

Traditionally, the equations used for calculation of cooling operation times in the food industry have been based on a 1st order approximation of Fourier's heat transfer equations (1). This is done by utilising a-values (a_m for the equilibrium temperature) as described by Pflug and Kopelman as a j-factor [1], and b values as described by Ball [2] as an f-factor.

$$\Omega = \sum_i^{\infty} a_i e^{-b_i Fo} \quad (1)$$

For non-ideal geometries the approach suggested by Newman [3] has been utilised. However, due to unequal boundary conditions and lack of symmetry these methods are not very precise under real life conditions. Simple model solutions have been suggested by Cleland and Earle [4] and Merts, Bickers and Chadderton [5]

for centre temperature prediction during cooling and these simple solutions requires thorough geometrical calculations.

Alternatively, and pushed by the technological advance in IT, calculations of cooling times have been performed using finite element modelling by Wang and Sun [6] and Amézquita, Wang and Weller [7]. These studies have also been focussing on point temperatures, and are conducted with assumed equal boundary condition, or calculated based on air velocity, which can be very difficult to measure in industrial setups.

FEM methods are precise but unfortunately time consuming and demand trained personnel. Further it necessitates that the boundary conditions are well described. When utilised properly FEM modelling can handle the unequal boundaries and asymmetrical geometries present in industrial cooling operations, and can serve as a powerful tool in validating and testing simple, deduced analytical models, when experiments are too laborious or impossible to conduct.

Many food products are cooled in the package, which often can be described as a semi-filled un-symmetrical plastic package with an air filled headspace. The products are typically cooled with a perpendicular airflow across the packages. This highlights the two major challenges when a simple equation should be developed for cooling processes: the boundary conditions are not equal and must be determined individually, and the geometry is asymmetrical. Thus the widely used method described by Newman [3] is not applicable in many situations, according to his own conclusions. However, by utilising the A/V ratio as the determining dimension, a different view on the geometry is achieved which is not dependent on the geometrical shape.

The Biot number in blast cooling is usually fairly low (below 5). In blast cooling operations the equilibrium temperature is often the target and the dimensionless temperature Ω will be low ($\Omega < 0.5$), therefore the Fourier number will be fairly high (above 0.2). This favours a simplification by utilising a 1st order approximation. In earlier studies [8] the Biot numbers of known geometries (infinite slab, infinite cylinders, spheres and cubes) have been investigated for Biot numbers below 5. An overall Biot number ($Biot_d$) of a specimen have been suggested to give similar results in cooling process evaluations compared to single dimension Biot numbers. The geometry's overall Biot number is suggested to be calculated based on A/V ratio, for the three finite specimens in the x,y,z domain as presented in eq. 2 and 3:

$$\frac{1}{Biot_d} = \frac{1}{Biot_x} + \frac{1}{Biot_y} + \frac{1}{Biot_z} \quad (2)$$

$$Biot_d = \frac{h}{k} \cdot \frac{V}{A} \quad (3)$$

Where V [m³] is the volume of the geometry, A [m²] is the surface area of the geometry, h [W/m²K] is the heat transfer coefficient, and k is the thermal conductivity of the food. Eq. 2 is suggested to apply for all irregular, asymmetric geometries [8].

The overall Biot number enables a single equation description of the heat transfer in 3-dimensional geometries. This requires that the "a"- and "b"- values can be expressed as single values for the specimen. To achieve this, the b values are plotted as b/Biot (4) as a function of Biot_d (3).

$$y = \frac{b}{Biot} \quad (4)$$

For the known infinite geometries (inf. slab, inf. cylinder and sphere) the b values can be expressed by eq. 5 by utilising a geometry factor, n [7] (slab=1, cyl=2, sphere=3) by curve fitting of b-values.

$$y = 0.0325 \cdot n^{1.35} \cdot Biot_d - 0.279 \cdot n^{0.65} \cdot Biot_d + 1 \quad (5)$$

Where n is the dimensionality, and Biot_d is the overall Biot number. The same relationship is utilised when handling irregular geometries.

As the a_m values for the first order approximation are determined based on point measurements [1], the solution suggested by [3] does not apply for modelling equilibrium temperatures. Thus no overall

determination of the a_m -value for finite elements exists. In this study the a_m values are proposed to follow eq. (6) based on the assumption that a_m values for finite elements can be calculated by a plot fit of the a_m for single dimensions as a function of the overall Biot number ($Biot_d$) and a dimensional factor (n), and the overall Biot number [8].

$$a_m = \left(\frac{4 \cdot n - 2}{100} \right) \cdot Biot_d + 1,01 \quad (6)$$

The expression of the b-values in eq. 4 gains continuity between the 1st order approximation of Fourier's equations and the lumped form used when no heat gradient is considered (for $Biot \rightarrow 0$, $y \rightarrow 1$). In the approach the y factor is denoted as b/Biot fulfilling the assumption of obtaining continuity. When the three known geometries are expressed by an overall Biot number, the "a" and "b" values can be calculated using eq. 5 and 6. The relationship between Ω and time (t) is then deduced to the following:

$$\Omega = a_m \cdot e^{-y \cdot \frac{A \cdot h}{V \cdot \rho \cdot c_p} \cdot t} \quad (7)$$

In eq. 7 the 1st order solution for Fourier's equations presented in eq. 1 is reduced from three equations down to one explaining all three dimensions for equilibrium temperatures, where ρ [kg/m³] is the density of the food and c_p [J/(kgK)] the specific heat capacity. The equation has been tested against a 6th order solution to Fourier's equation for cylinders, cubes and spheres with comparable results for Biot numbers below 5 [8] with good agreement, and with an advantage of handling irregular geometries, where three single Biot numbers are not determinable.

In this study the governing equations of Fourier in eq. 8 have been solved for the experimental geometry using COMSOL Multiphysics to simulate the conducted wet experiments.

$$\rho c_p \left(\frac{\partial T}{\partial t} \right) = k \left[\frac{\partial^2 T}{\partial x^2} + \frac{\partial^2 T}{\partial y^2} + \frac{\partial^2 T}{\partial z^2} \right] \quad (8)$$

MATERIALS & METHODS

For the experimental validation of the new developed equation a puree was made of soaked, boiled and blended chickpeas as a model system. The dry matter content of the puree was 25 % [w/w], and the thermo-physical properties calculated to; thermal conductivity 0.538 [W/(mK)], density 1072 [kg/m³], heat capacity 3591 [J/(kgK)]. The chickpea puree was cooled in a blast freezer and the temperature measured by T-type thermo couples in seven measuring points through a custom made geometry (100x100x300mm aluminium with a thickness of 2 mm), as presented in figure 1.



Figure 1 Geometrical setup of the experiments in the blast cooler

To determine the local heat transfer in the blast cooler, a solid aluminium block was used. The aluminium block was isolated from all sides except one using polystyrene, and placed in the cooler to determine the temperature history of all six sides of the block singularly, using T-type thermo couples. The local heat transfer was calculated based on the lumped equation for transient heat transfer, assuming a very low Biot number for the aluminium block (<0.01).

The experiments were simulated using COMSOL Multiphysics, with the measured local heat transfer coefficients as boundary conditions. The x,y,z-coordinates of the T-couples in the simulation was compared with the experimental results based on six point temperature curves to validate the conformity between the simulations and experiments. The calculated equilibrium temperatures from the simulations have been used

for validation of the simple model. Further validation of the new equation (7) is conducted by comparison with a 6th order solution to Fourier's series (in eq. 1) in an excel-based program, BIC-Simula, developed at the institute by associate professor Jørgen Risum. Calculations based on the programme is in this article noted BIC-Simula.

RESULTS & DISCUSSION

The local heat transfer coefficients were measured in a blast cooler to determine the boundary conditions for the simulations of cooling processes in the equipment. Based on the heat flux across a solid aluminium block, the heat transfer coefficient was calculated based on the lumped equation for transient heat transfer. It is clear that the local heat transfer coefficients are different on the six boundaries in table 1. Thus the COMSOL simulations should preferably be computed using the local heat transfer coefficients. The results also indicate that in case of headspace in the packaging material the local heat transfer is reduced significant, (from 30 to 10 [W/(m²K)], but is still too high to neglect and use the approach suggested by [3].

Table 1. Local heat transfer coefficients

Geometry position	Local heat transfer coefficient [W/m ² K]
back	24,5
sides	27
front	33
bottom	35
isolated bottom	0
top	
-direct flow	32
-headspace 28 mm	7
headspace 10 mm	9
headspace 5 mm	10

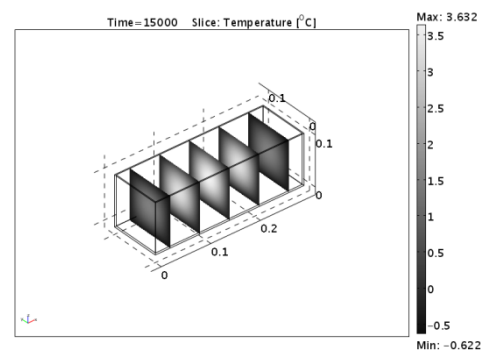

Figure 2 Temperature distribution at t=15000s for the COMSOL simulation

The COMSOL simulation is compared with the experiments in figure 3 for six measurements during blast cooling of chickpea puree.

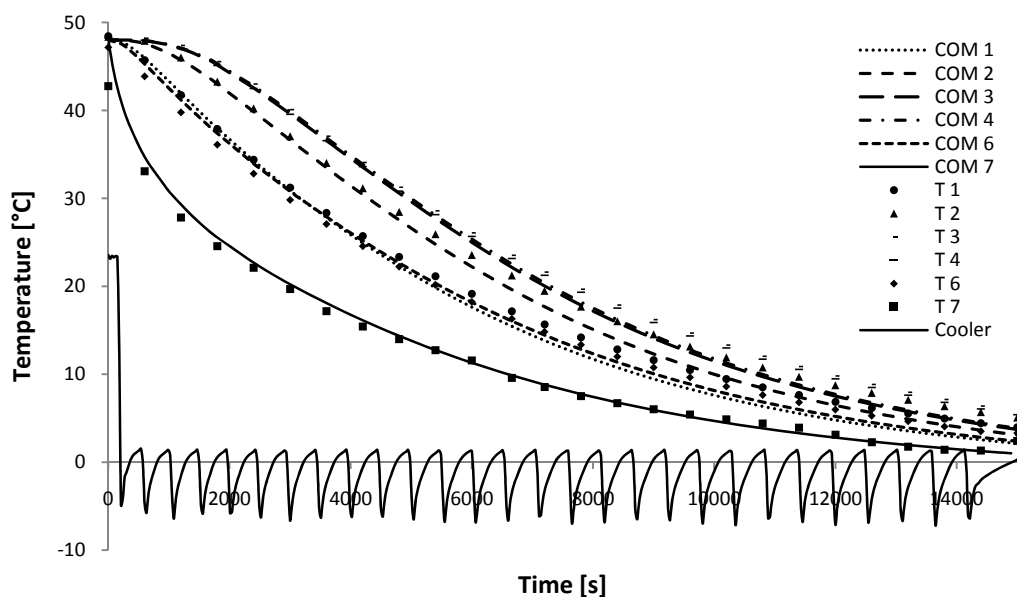

Figure 3 Comparison of the measured Temperature points during cooling of chickpea puree in a blast cooler (T1, T2, T3, T4, T6, T7), with the corresponding simulated temperature curves (COM1, COM2, COM3, COM4, COM6, COM7) at the x,y,z points in COMSOL.

The simulated and experimental results show good agreement with only minor deviations at the positions close to the centre (-2°C). The simulations are thus used as *in silico* experiments for the validation of the new model for equilibrium temperature. The equilibrium temperature are calculated from the simulation and used for comparison with the developed eq. 7. This approach will make it possible to test irregular geometries with unequal boundary conditions and headspace in simulations to further validate the new eq. 7. The simulation and the developed model are compared in figure 4, 5, 6 and 7 for different geometries. In Table 2, the maximum error between the simulation and the simple model are listed. The simulated cooling curve for equilibrium temperature is compared to the calculated cooling curve from eq. 7, and a 6th order approximation for finite elements.

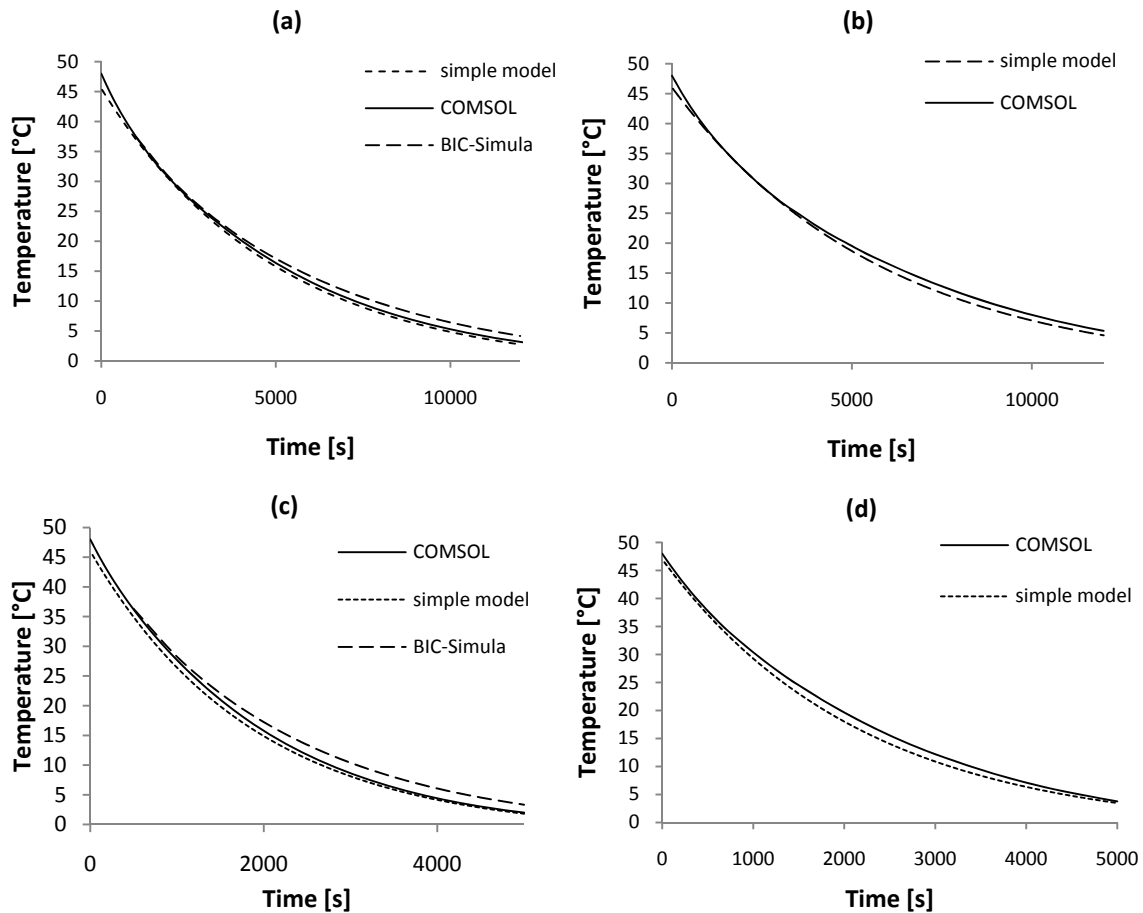

Figure 4 Comparison of the simulated temperature curves by COMSOL and the calculated equilibrium temperature using the new model (7), the four graphs presented are free standing geometry (a)(100x100x300mm), free standing geometry with headspace (b)(100x100x300mm), free standing geometry (c)(50x50x150mm) and a free standing geometry with headspace (d)(50x50x150mm).

From the results in Figure 4, the new model is able to describe the evolution of the equilibrium temperature with good precision. At high Fourier numbers, the simple model predicts the same equilibrium temperatures as found in the COMSOL simulations.

Table 2. Maximal error in degrees centigrade between simulated equilibrium temperatures and prediction of the temperatures using the new model.

Geometry	Centigrade error maximum	Error at target (5°C)
Geometry (a)	+1,5 [°C]	<0.5[°C]
Geometry (b)	+2 [°C]	<1 [°C]
Geometry (c)	+1.5 [°C]	<0.5 [°C]
Geometry (d)	+2 [°C]	<0.5 [°C]

The results presented in Figure 4 and the errors summed in Table 2 indicate good precision in predicting equilibrium temperatures using the new equation. An important notice is that the error in the latter part of the prediction curve is very small (large Fo-numbers). Thus in the final equilibrium temperature prediction the error is insignificant compared to experimental error, because the target of importance during cooling is the final equilibrium temperature. The simplification has not harmed the prediction of equilibrium temperatures when compared to the BIC-SIMULA calculations.

It should be noted that the suggested solution to handle cooling and equilibrium temperatures are only validated for specimens with a Biot number below 5. The future scope is to further develop the simple model, with respect to the equation description of the “a” and “b” values, to enable handling products with larger Biot numbers, and to investigate the possibility of incorporating mass transfer into a single equation.

CONCLUSION

An experimental setup has been used to enable simulations for the prediction of equilibrium temperature during cooling of foods in packaging materials. The simulation has proved a powerful tool for the validation of simple prediction models.

It is possible to conduct easy calculation of cooling times for foods in packaging materials in industrial applications, where the boundary conditions are unequal, and the package is asymmetrical, by utilising the simple model presented in eq. 7.

The newly developed model has proven quite precise in equilibrium temperature prediction in the performed simulations based on a few industrial measurable variables (A/V ratio, thermo physical data and heat-flux). The temperature error was low (<0.5°C) in the final equilibrium temperature prediction. Due to the analytical form of the model it is implementable in excel spreadsheets and could serve as a powerful tool for fast and easy cooling time prediction in daily operations in the food industry.

REFERENCES

- [1] Pflug, I. J., Bleidsdell, J. L., Kopelman, J. (1965) Developing Temperature-Time Curves for Objects That Can Be Approximated By a Sphere, Infinite Plate, or Infinite Cylinder *ASHRAE semiannual meeting January 25-28 1965 in Chicago, Michigan*
- [2] Ball, C., O. (1923-1924) Determining, By Methods of Calculation, The Time Necessary To Process Canned Foods. *Bulletin of the National Research Council, Volume 7 (37):9-76*
- [3] Newman, A.B. (1936) Heating and cooling rectangular and cylindrical solids. *Industrial and Engineering Chemistry*, 28, 545-548
- [4] Cleland, A.C. and Earle, R.L. (1982) A simple method for prediction of heating and cooling rates in solids of various shapes. *International Journal of Refrigeration*, 5, 2, 98–106
- [5] Merts, I. Bickers, E.D. and Chadderton, T. (2007) Application and testing of a simple method for predicting chilling times for hoki (*Macruronus novaezelandiae*). *Journal of Food Engineering*, 78, 162-173
- [6] Wang, L. and Sun, D. W. (2002) Modelling three conventional cooling processes of cooked meat by finite element method. *International Journal of Refrigeration*, 25, 100-110
- [7] Amézquita, A., Wang, L., Weller, C. L. (2005) Finite Element Modeling and Experimental Validation of Cooling Rates of Large Ready-To-Eat Meat Products in Small Meat-Processing Facilities. *ASAE American Society of Agricultural Engineers ISSN 0001-2352*
- [8] Christensen, M. G., Adler-Nissen, J (2010). Robust Modeling for Processing of Ready-Made Meals. *Conference paper: Food Factory of the Future*. Gothenburg 1. July 2010