



Wind power plant system services

Basit, Abdul; Hansen, Anca Daniela; Sørensen, Poul Ejnar; Altin, Müfit

Publication date:
2014

Document Version
Publisher's PDF, also known as Version of record

[Link back to DTU Orbit](#)

Citation (APA):

Basit, A., Hansen, A. D., Sørensen, P. E., & Altin, M. (2014). Wind power plant system services. DTU Wind Energy. (DTU Wind Energy PhD; No. 0043(EN)).

DTU Library

Technical Information Center of Denmark

General rights

Copyright and moral rights for the publications made accessible in the public portal are retained by the authors and/or other copyright owners and it is a condition of accessing publications that users recognise and abide by the legal requirements associated with these rights.

- Users may download and print one copy of any publication from the public portal for the purpose of private study or research.
- You may not further distribute the material or use it for any profit-making activity or commercial gain
- You may freely distribute the URL identifying the publication in the public portal

If you believe that this document breaches copyright please contact us providing details, and we will remove access to the work immediately and investigate your claim.

Wind Power Plant System Services

DTU Wind Energy
PhD Thesis 2015

Abdul Basit

DTU Wind Energy PhD-0043 (EN)

December 2014

DTU Vindenergi
Institut for Vindenergi



Author: Abdul Basit

Title: Wind Power Plant System Services

Department: DTU Wind Energy

Summary (max 2000 characters):

Increasing levels of wind power penetration in power systems has posed serious concerns to the system operators, particularly the power balance control. The wrong forecast in a highly wind power integrated power system deviate the generation and power exchange from its cost effective calculated schedule and can also lead to balancing and control problems; introducing several challenges in maintaining the reliable power system operation in the absence of adequate power reserves. The increasing integration of wind power is going more and more to replace conventional power plants, the sources of conventional reserves. The reliable operation of highly wind power integrated power system might then be at risk unless the wind power plants (WPPs) are able to support and participate in power balancing services. This PhD project 'Wind Power Plant System Services' develops and analyses the control strategies which can increase the WPPs capability to provide system services, such as active power balancing control, in a modern power system with large scale integration wind power. This PhD study proposes a novel and practical approach of integrating the WPPs control into the AGC. This is based on a coordinated control strategy between CHPs and WPPs, improves the active power balance in the power system with minimum secondary dispatch cost. Moreover, this study has also analysed the case where secondary control is provided by WPPs and flexible consumption units. The main results of this research work show that the WPPs can actively contribute to power balance control through primary and secondary response. The integration of WPPs control into the AGC is of high relevance, particularly in situations when wind power is contributing highly to the total electricity production and conventional power plants are operating on the minimum level. The grid support services from WPPs improve the active power balance control and make power system operation more reliable. The PhD research work is carried at the Technical University of Denmark (DTU) in the Wind Energy Department with the collaboration of Energinet.dk and it is funded by the Sino Danish Centre for education and research (SDC).

2014

Project period:

15.12.2011 – 22.03.2015

Education:

Doctor of Philosophy (PhD)

Supervisors:

Anca D. Hansen
Poul E. Sørensen
Mufit Altin

Contact No.:

45252525

Report number:

DTU Wind Energy PhD-0043 (EN)

ISBN: 978-87-93278-16-5

Sponsorship:

Sino-Danish Center for Education
and Research

Technical University of Denmark

Department of Wind Energy
Frederiksborgvej 399
Building 118
4000 Roskilde
Denmark
Phone 46 77 50 24
abdl@dtu.dk
www.vindenergi.dtu.dk

I dedicate this thesis to my family for their constant support and unconditional love.

I love you all dearly.

Wind Power Plant System Services

Abstract

Traditionally, conventional power plants have the task to support the power system, by supplying power balancing services. These services are required by the power system operators in order to secure a safe and reliable operation of the power system. However, as in the future the wind power is going more and more to replace conventional power plants, the sources of conventional reserve available to the system will be reduced and fewer conventional plants will be available on-line to share the regulation burden. The reliable operation of highly wind power integrated power system might then be at risk unless the wind power plants (WPPs) are able to support and participate in power balancing services.

The objective of this PhD project is to develop and analyse control strategies which can increase the WPPs capability to provide system services, such as active power balancing control, in a modern power system with large scale integration wind power. This study presents the investigation of the real-time balance control in a modern Danish power system, where WPPs can actively contribute to active power balance control. New solutions for the automatic generation control (AGC) dealing with the compensation of the power imbalances between demand and generation in real time, caused by wind power forecast errors, to enhance the security and the reliability of a power system operation with large wind power penetration with the coordination between combined heat and power plants (CHPs) and WPPs are developed and analysed.

The main results of this research work show that the WPPs can actively contribute to power balance control through primary and secondary response. The integration of WPPs control into the AGC is of high relevance, particularly in situations when wind power is contributing highly to the total electricity production and conventional power plants are operating on the minimum level. The grid support services from WPPs improve the active power balance control and make power system operation more reliable.

The research work is carried at the Technical University of Denmark (DTU) in the Wind Energy Department with the collaboration of Energinet.dk and it is funded by the Sino Danish Centre for education and research (SDC).

Wind Power Plant System Services

Resume på Dansk

Øget brug af vindkraft i el-systemer giver de systemansvarlige alvorlige bekymringer med hensyn til sikkerhed og pålidelighed af el-systemer, især hvad angår kontrollen af energibalancen.

Vindhastighedsprognoser spiller en vigtig rolle i denne sag, da en forkert prognose i et system med meget integreret vindkraft, kan føre til ubalancer og kontrolproblemer, og give en række udfordringer med at opretholde en pålidelig drift af el-systemet på grund af utilstrækkelige energireserver.

Konventionelle kraftværker har typisk til opgave at støtte el-systemet ved at levere den rette mængde strøm. Men i fremtiden, vil vindkraften erstatte konventionelle kraftværker, kilderne til konventionelle kraftværker vil blive reduceret og færre konventionelle anlæg vil være tilgængelige online og derved dele fordelingsbyrden. En pålidelig drift af et el-system baseret på en høj grad af vindkraft kan være risikofyldt med mindre vindkraftværker er i stand til at støtte og deltage i energi-fordelingstjenester.

Formålet med dette ph.d.-projekt, ”Wind Power Plant System Services” er at udvikle og analysere kontrolstrategier, som kan øge WPPs kapacitet til at yde systemtjenester, såsom aktiv effekt-balanceringskontrol i et moderne el-system med stor-skala integration af vindkraft. Forskningsarbejdet er udført på Danmarks Tekniske Universitet (DTU) i Afdelingen for Vindenergi i samarbejde med Energinet.dk og er finansieret af Sino Dansk Center for Uddannelse og Forskning (SDC).

Denne afhandling har udviklet et dansk el-system, der omfatter automatisk genereringskontroller (AGC), aggregerede modeller for WPP, kombineret centraliseret og decentraliseret kraftvarmeværk (hhv. CHP og DCHP) and sammenkoblinger med nærliggende el-systemer. De aggregerede modeller for generede enheder er udviklet med henblik på at reducere beregningsindsatsen, men stadig indeholdende de dynamiske egenskaber, som måtte være relevante for særlig undersøgelse, dvs. aktiv energibalancekontrol. El-systemmodellen tager genereringen og kraftværkskapaciteten for 2020 med i betragtning og gør brug af input, som genereres en time i forvejen hvert femte minut ved langsigtede dynamiske simuleringstudier. Inputs givet en time i forvejen er leveret af ”Simulation Power Balancing-modellen (SimBa), som er udviklet af Dansk TSO (Energinet.dk) i samarbejde med DTU.

Denne undersøgelse har foreslået, og præsenteret en ny og praktisk tilgang til at integrere WPP kontrol i AGC. Dette er baseret på en koordineret kontrolstrategi mellem kraftværker og WPPs. Det er blevet bemærket, at den koordinerede kontrolstrategi forbedrer den aktive effektbalance i el-systemet med minimale sekundære afsendelsesomkostninger. I den henseende regulerer kontrolstrategien den aktive effektproduktion fra kraftværkerne og WPPs afhængig af driftsreserverne, afsendelsesbegrænsninger og produktionsomkostninger. WPPS'erne kan give op- eller nedregulerende tjenester, betinget af tilgængeligheden af vindenergiresserver. Ydermere har denne undersøgelse også analyseret det tilfælde, hvor fornyet kontrol leveres af WPPs og forbrugsenheder, hvor AGC nedregulerer den fleksible belastning ved negative strømbalancer og WPP-produktionen ved positive strømbalancer. Denne ph.d.-afhandling har også udviklet en algoritme til aktivering af manuelle reserver. Algoritmen navngivet som "rullende balance" imiterer kontrolrummets respons, samtidig med at den aktiverer reguleringskraften for sikker drift af el-systemet.

De vigtigste resultater af denne forskning viser, at WPPs aktivt kan bidrage til kontrol af energibalancen gennem primær og sekundær reaktion. Integrationen af WPPs kontrol i AGC er af stor relevans, især i situationer, hvor vindkraft bidrager stærkt til den samlede el-produktion og konventionelle kraftværker opererer på minimumsniveauet. Ledningsnettets støtte fra WPPs forbedrer den aktive effekt balancekontrol og gør driften af el-systemet mere pålideligt.

Acknowledgements

I would like to express my special gratitude and thanks to my supervisors; to my main supervisor, Anca Daniela Hansen, and to my co-supervisors, Poul Ejnar Sørensen and Müfit Altin, for their guidance, support, encouragement, and valuable contributions throughout my doctorate study.

Special thanks and acknowledgement to Danish TSO, Energinet.dk, for their valued contribution to my doctorate study.

I am thankful to Prof. Xu Honghua and Dr. Hu from Institute of Electrical Engineering Chinese Academy of Sciences (IEE-CAS), China, where I stayed for six months as an external PhD student.

I am thankful to my colleagues and manager at the Wind Energy Systems (DTU Wind Energy), for their knowledge sharing, support, friendship and very good times together. I had the satisfaction of enjoying a PhD student life, with good times and friendship.

A special thanks to my family. Words cannot express how grateful I am to my mother and my aunts for all of the sacrifices that you've made on my behalf. Your prayer for me was what sustained me thus far. I would also like to thank to all of my family members for supporting me, and especially I can't thank you enough for encouraging me throughout this experience.

I am also thankful to my teachers and my friends from Pakistan, for their support and encouragement.

I gratefully acknowledge that this doctoral study was financially supported by the Sino Danish Centre for education and research (SDC).

Table of contents

Abstract.....	iii
Resume på Dansk.....	v
Acknowledgements.....	vii
Table of contents.....	ix
List of abbreviations and symbols	xiii
Chapter 1 Introduction	1
1.1 Background.....	1
1.1.1 Wind power in Danish power system	2
1.1.2 Impact of large scale wind power integration	3
1.1.3 Challenges for future Danish power system	4
1.2 State of the art.....	5
1.3 Research objective.....	8
1.3.1 Research approach.....	9
1.3.2 Project limitation.....	10
1.4 Contributions	10
1.5 Thesis outline.....	11
1.6 List of publications	12
Chapter 2 Danish power system	13
2.1 Danish power system overview	13
2.1.1 Eastern Danish power system	13
2.1.2 Western Danish power system	14
2.2 System Interconnections.....	15
2.2.1 Great Belt Link.....	15
2.2.2 Eastern Danish power system interconnections	15

2.2.3	Western Danish power system interconnections.....	15
2.3	Electrical power generation	16
2.3.1	Conventional power plants.....	17
2.3.2	Wind Power Plants	20
2.4	Summary.....	22
Chapter 3	Technical requirements and regulations for active power balance control.....	23
3.1	Regulations for active power balance control	23
3.1.1	Primary control.....	25
3.1.2	Secondary control.....	29
3.2	Requirement for balancing reserves	32
3.2.1	Primary control reserves.....	33
3.2.2	Secondary controlled reserves.....	35
3.2.3	Manual reserves.....	36
3.3	Active power regulation from WPPs.....	37
3.3.1	System protection	37
3.3.2	Frequency control.....	37
3.3.3	Constraint functions	38
3.4	Summary.....	41
Chapter 4	Power system modelling and control	43
4.1	Hour-ahead Regulating power plan	43
4.1.1	Balancing concept of Danish power system	44
4.1.2	Simulation Power Balancing (SimBa) model	45
4.2	Modelling of Automatic Generation Control (AGC)	50
4.3	Dispatch strategy – Integrating WPP in AGC control.....	53
4.3.1	Secondary dispatch strategy between CHPs and WPPs.....	54
4.3.2	Secondary dispatch Process	56
4.4	Rolling balance – activation process for manual reserves.....	57
4.5	Summary.....	60

Chapter 5	Component modelling	61
5.1	System interconnections	61
5.1.1	Power exchange ramp rates	62
5.1.2	Modelling system interconnection	63
5.2	Combined heat and power plant (CHP).....	64
5.2.1	Modelling CHP unit	64
5.2.2	Model performance – CHP power plant	68
5.3	De-centralized Combined Heat and Power plant (DCHP)	73
5.3.1	Modelling DCHP unit	73
5.3.2	Model performance	77
5.4	Wind Power Plants (WPPs).....	79
5.4.1	Modelling WPP	80
5.4.2	Model performance – Aggregated WPP	83
5.5	Summary.....	87
Chapter 6	System analysis with large scale integration of wind power	89
6.1	Dynamic analysis of power system model	89
6.1.1	Primary response	90
6.1.2	AGC controlled secondary response	92
6.2	Impacts of wind uncertainty on power system operation	96
6.3	Integration of WPP control in AGC system	102
6.3.1	WPP operating in Delta mode.....	102
6.3.2	WPP generating available power	107
6.3.3	Analysis during critical weather condition.....	110
6.4	Impact of programmed regulating reserves	113
6.5	Integration of consumption units and WPP in AGC system	117
6.6	Summary.....	121
Chapter 7	Conclusions and future work	123
7.1	Conclusions	123

Wind Power Plant System Services

7.2 Future work.....	125
References.....	127
Appendix: Models parameters	135
Publications.....	139

List of abbreviations and symbols

<i>Abbreviation/Symbol</i>	<i>Definition</i>
TSO	Transmission System Operator
CE	Continental European
NOIS	Nordic Operational Information System
ENTSO-E	European Network of Transmission System Operators for Electricity
AGC	Automatic Generation Control
CHP	Combined Heat and Power Plant
DCHP	De-centralized Combined Heat and Power Plant
WPP	Wind Power Plant
AC	Alternating current
HVDC	High Voltage Direct Current
GBL	Great Belt power Link
FCR	Frequency Containment Reserve
FRR	Frequency Restoration Reserve
RR	Replacement reserve
FCNOR	Frequency Controlled Normal Operation Reserve
FCDR	Frequency Controlled Disturbance Reserve
FADR	Fast Active Disturbance Reserve
SDR	Slow Disturbance Reserves
SimBa	Simulation Power Balancing
CorWind	Correlated Wind power fluctuations
WILMAR	Wind Power Integration in Liberalised Electricity Markets
PCC	Point of Common Coupling

Wind Power Plant System Services

UC	Unit Commitment
ED	Economic Dispatch
B	AGC bias setting
β	power frequency characteristics of network or generating unit
f_{ss}	steady state frequency after power imbalance
D	load damping constant
β_{PS}	frequency response from generating units
P_{ACE}	Area Control Error, calculated by AGC
R	Droop of the speed governor
Δf	frequency deviation
P_n	nominal power
f_n	nominal frequency
P_{ref}	reference power set point
PI	Proportional Integral
K	proportional term of PI controller
T	integral time constant of PI controller
LR	Load reference set point for CHP unit
cv	Control Valve of speed governor
GRC	Generation Rate Constraint of CHP unit
EV	Environment combustion chamber of DCHP unit
VIGV	Variable In-let Guide Vane of DCHP unit
SEV	Sequential Environmental combustor of DCHP unit
CLC	Command Load Change in DCHP unit

Chapter 1

Introduction

This thesis presents the development and investigation of methodologies for active participation of wind power in the power balance control of power systems with large wind power penetration. New solutions for the automatic generation control (AGC) dealing with the compensation of the power imbalances between demand and generation in real time, caused by wind power forecast errors, and with the coordination between combined heat and power plants (CHPs) and wind power plants (WPPs) to enhance the security and the reliability of a power system operation with large wind power penetration are developed and analysed.

1.1 Background

Nowadays, the global energy challenge is not only to satisfy the growing energy demands but also to generate electricity from safer, cleaner and environmental friendly energy sources. In this respect the renewable energy is an important source for electricity generation with no pollution and global warming emissions. The renewable sources such as hydro, wind, solar are available almost all over the world.

In the last decades, renewable energy has experienced significant growth worldwide mainly due to global environmental concern. Of renewable energies, the wind energy is one of the fastest growing resources for electricity generation. Wind power is increasingly being viewed as a mainstream electricity supply technology and has raised ambitious targets in many countries around the world. The main reasons for the fast increasing integration of wind power into the power system over the last decade are:

- *Very low CO2 lifetime emission*
- *Significantly exploitable resource potential*
- *No cost uncertainties from fuel supply price fluctuations*
- *Can be rapidly installed*
- *Opportunity for industrial, economic and rural development*

According to [1], 318 GW of wind power has been installed globally till the end of 2013, where 35.3 GW was installed only in 2013. China holds the largest capacity of WPPs worldwide, i.e. 91.4 GW. Other countries having large wind power capacities are United States (61 GW), Germany (34.2 GW), Spain (22.95 GW) and India (20.15 GW).

Large scale integration of wind power in modern power systems sets new challenges in power system operation raising concerns around dynamic security and reliability. Replacement of conventional power plants by WPPs of similar size increases the risk of system failures, challenging the security and reliability of the power system.

1.1.1 Wind power in Danish power system

As the pioneer in the electricity generation from wind power, Denmark is among the top 10 countries having the largest wind power capacity [1]. The electricity generation from wind power started in late seventies and gained growth in nineties. Figure 1 depicts for example the growth of wind power in Danish power system during the last three decades, while Figure 2 shows the wind power share in the total electricity consumption during the last thirteen years [2]. It is worth noticing that, in 2000, Denmark had an installed wind capacity of 2,390 MW, which produced 0.57 TWh of energy and covered 12.1% of the total electricity generation. In 2010, the capacity grew up to 3,752 MW and to 4,792 MW by the end of 2013.

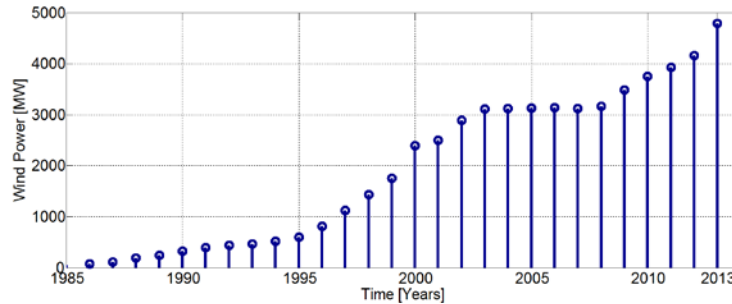

Figure 1: Wind Power development in Denmark over the last three decades

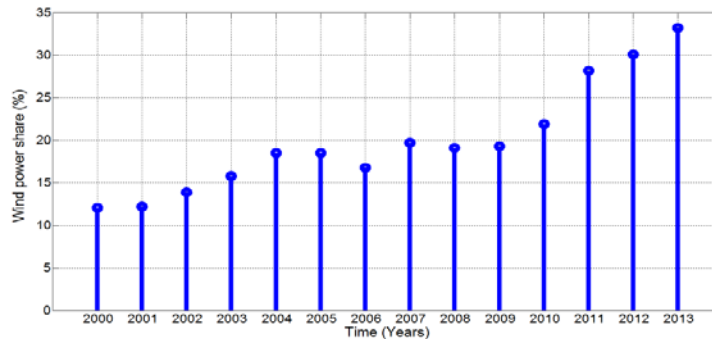

Figure 2: Wind Power share in Denmark

At the end of 2013, Denmark has highest wind power penetration level globally with the generating capacity of 4.79 GW [1]. The installed wind power generated 11.1 TWh during the year 2013 and shared 33.2% of the electricity consumption in the entire year, when the total electricity consumption in the Danish grid was 33.5 TWh [3]. Moreover, the wind power shared 50% of total electricity consumption in the month of December 2013 and 102 % on 21st of December, 2013.

Due to its continuing increasing wind power penetration over the years, Denmark is also one of the first to face the possible problems and challenges due to large scale integration of wind power. The large integration of wind power in the Danish power system sets new challenges in power system operation raising concerns around dynamic security and reliability. The future is even more alarming, as the Danish government aims to increase the wind power share in electricity system to 50% by 2020 and 100% renewables by the year 2050 [4]. This large scale integration of wind power will possibly replace some of the traditional power plants and thus might affect the security and reliability of the power system operation, unless the existing operational strategies of the power system are revised.

It is to mention here, that the wind power penetration is commonly defined as either energy penetration or capacity penetration. Energy penetration is the ratio of the amount of energy obtained from the wind generation to the total energy consumed in the power system, normally on an annual basis. Capacity penetration is defined as the ratio of the installed wind power capacity to the peak load consumption on a specified time period. In this study, the wind penetration or integration refers to the energy penetration.

1.1.2 Impact of large scale wind power integration

Increasing levels of wind power penetration in power systems has posed to the system operators serious concerns regarding the security and reliability of the power system operation. Some of the problems that need intensive research include issues like: frequency control, power balance control, voltage stability and reserves availability. Furthermore, the challenges associated with unit commitment (UC), economic dispatch (ED) and AGC are also needed to be addressed [5]. Frequency control problems are typically prominent in small or standalone power systems as less number of generating units contribute to primary response. In a large interconnected power system, power balance is one of the main challenges that need to be evaluated for large scale integration of wind power [6]. For operational security, the transmission system operators (TSOs) must continually ensure that the generation and load demand are in close balance. Beside this, the variability of wind power impacting the power system operation is also an important factor, which should be taken into consideration, as it depends on the penetration level, intermittency of the wind resource, power system size, generation capacity mix, load variation

and interconnections with neighbouring power systems [5, 7, 8, 9, 10]. Wind power forecast can create even more problems during extreme weather conditions, if not predicted timely.

In traditional power systems, the average load almost varies in predictable patterns, except for the unforeseen events [11]. These variations are compensated with additional generation capacity kept as reserves. The reserves are provided by the conventional power plants which are also responsible for controlling the grid frequency. Introducing wind generation into the power system increases the regulation burden and need for reserves, due to its natural intermittency. It is the responsibility of TSOs to always ensure that sufficient reserves are available for keeping the system in balance to deal with wrong wind power forecasts [8], even though this strategy increases the operating cost of the power system.

Accuracy of wind power forecast is essential in a reliable and active integration of wind power into the power system. Large wind power forecasting errors may compromise the proper dispatch of the generators and the determination of the required power reserve levels. They contribute majorly to the deviations in planned power generation which lead to power system control and balancing problems. The forecasting error also deviates the power exchange from its schedule, affecting the transmission capacity on interconnections. As result, the reliability of power system is challenged if power production capacity is not sufficient to meet the demands at all time. The large scale integration of wind power challenges therefore a power system operator to maintain the balance between production and consumption in power system and the power exchange at its schedule.

The operational security is particularly at risk during extreme weather condition, as it may result in loss of large amount of wind power within minutes [12, 13]. Therefore, the availability of system reserve and power ramping of generation units must be taken into consideration while analysing the power balance control in a large scale wind power integrated power system [11].

Moreover, in future power systems, the increasing large scale integration of wind power may replace the conventional power plants. The sources of conventional reserve available to the system may be therefore reduced and fewer conventional plants may be available on-line to share the regulation burden. In these situations, the reserve management by conventional plants is difficult due to their limited capability in power regulation. Consequently, wind power forecasts might introduce large power imbalances leading to frequency control and operational issues unless WPPs actively participate in the active power balance control on the power system level.

1.1.3 Challenges for future Danish power system

The dispatch-able generation in traditional power system balances the forecasted load with least error. However, the challenges are becoming more serious with the addition of intermittent wind power. During the first two decades of wind turbines (1980-2000), small scale integration of

wind power didn't pose significant challenge to power system operation. However, with increasing wind power integration, secure operation of the power system gets significantly affected and demands strong attention. In a large interconnected power system, such as Denmark, power balance is one of the main challenges that need to be evaluated for large scale integration of wind power [14].

Presently, the Danish power system has highest wind power penetration level in the world and it met 33.2% of the total generation in 2013 [1]. In this context, wind power forecast is a serious challenge for the Danish power system, as only 1 m/s increase or decrease in a wind speed between 5 – 15 m/s may generate a power imbalance of approximate 350 MW [15]. This power imbalance deviates the power exchange with Continental European (CE) and Nordel power systems and might overload the transmission lines. Although, the strong interconnections with CE and Nordel offer large frequency response and helps in restricting the frequency deviations in the Danish power system. The existing Danish power system is capable of handling wind power variations when 33.2% of the electricity consumption is provided by the wind power; however operation and control methods need to be reviewed for future integration of wind power, when 50% of the electricity has to be supplied by wind power or 100% by the renewable sources.

The presence of significant amounts of wind generation in future Danish power system require some prudent adjustments of the operation strategy of power system, as wind power forecast may affect the deployment and operation of other generating resources in a balancing area. In this sense, it is of high relevance to identify and find solutions to minimize the impacts of wind generation on system performance. It is required to develop and analyse models and control strategies for WPPs, which increase their capability to provide ancillary services, especially power balancing support in modern power systems with high wind power penetration.

This project focuses on developing methodologies with specific aim of solving the power balance control problems in power systems with high wind power penetration and on investigation of the active power control ability of different generating units' in future Danish power system, such as CHPs and WPPs.

1.2 State of the art

Increasing large scale integration of wind power into power systems challenges the system operators especially in respect to the security issues, as WPPs are expected to replace more and more conventional units on the production side in the future. This means that for shorter or longer periods, some of the duties carried out today by conventional power plants, will have to be delivered in the future by WPPs [16, 17, 18, 19]. They will have to support the grid by supplying ancillary services. The ancillary services represent a number of services required by

the power system operators, such as to participate actively in the power balance, in order to secure safe and reliable grid operation.

The WPPs contributing in ancillary service is a challenging technical issue, which has initiated an intensification of this research area in academia and industry. Several studies regarding this issue, i.e. active contribution in balance control, have been performed over the world in the last few years. The wind turbines contributing to active power control is dependent on the ability to respond to the system frequency change or operators' demand, which can be obtained either mechanically through pitch control or kinetically through rotor over-speeding [20, 21, 22, 23, 24, 25].

Initially, the concept of negative load has been applied to the wind turbines to indicate their passive role in the power system. However as the electricity production from wind power increased, the researchers started to investigate the possibility of wind turbines to behave as active controllable components in the power system. Investigations on how to control wind power to provide frequency response have been in the attention of wind power industry and academia over the last few years. The wind turbines power can temporarily support the grid during a frequency deviation by injecting additional power into the system [26] [27]. The study in [28] suggests that the frequency response from wind turbines can be improved with techniques like, hybrid over-speeding de-loading control scheme and combined strategy of pitch controlled with inertial support.

Numerous studies are reported on the WPP control level, where the hierarchical control architecture controls the WPP response by sending out reference power signals to each individual wind turbine [29]. The WPPs are required to provide different control functions, like balance control, delta control or frequency control [30]. The work in [31] describes the real-time operational experience of Horns Rev offshore wind farm in Denmark, providing the aforementioned control services. The study in [32] suggested that the wind power can provide better regulation services for frequency control, if grouped in clusters. This approach increases the overall performance of the WPPs on power system level. This and the increasing large scale integration of wind power therefore require studying the collective performance of WPPs on the power system level, contributing to real-time power balance control.

On system level, the aggregated performance of conventional power plants, WPPs, loads and system interconnections is needed to study the operational security of the power system. The TSOs of highly wind power penetrated power system must be able to deal with the wind power forecast error that deviates the power generation from its schedule and leads to power system control and balancing problems. Several studies are reported on this topic, but they adopt the conventional power plant approach to minimize the power imbalance in real-time. For-example: a Chinese study uses conventional generators to control the fluctuation from wind power [33] to

improve power system performance. Whereas, a Dutch case study controls the power imbalance originating from wind power through AGC and finds that additional reserves from conventional power plants are required in future for keeping the area control error (P_{ACE}) within acceptable limits [34]. Some studies on the active power balance control in the Danish power system models are described in [6, 35, 9, 10, 7, 14]. These studies investigate the ability of the secondary control from conventional power plants, the spinning reserves from CHPs for maintaining the power balance in Danish power system and the power exchange at its schedule. However, the increasing large scale integration of wind power in modern power system requires more and more services from WPPs similar to those provided by conventional plants. Of ancillary services from WPPs, the ability to actively participate in maintaining the active power balance control is in focus for this PhD thesis.

Detailed studies regarding the provision of grid support services by WPPs is performed for the European grid in [36, 37]. According to these studies, systematic investigation of wind power technology confirms that WPPs are technically capable of providing grid support services. The alternating current (AC) connected onshore and offshore WPPs can provide active power reserve and frequency response in all time domains, i.e. primary, secondary and tertiary. However, the WPPs performance when providing a service can be improved by aggregating the WPPs, where implementation of better and faster communication systems (between WPPs and system operators control room) is essentially required. These studies also suggest that the control strategies should be tuned and improved to obtain the maximum power performance and flexibility from wind generation.

The developed control methods and available reserves are suitable to deal with the load variations and variable supply of power from WPPs in existing power systems. However in future power systems, advanced control methods of operation and additional reserves are needed to accommodate further integration of wind power. This PhD thesis investigates solutions in this direction. Progress is being made, with knowledge from recent studies, in developing methods to operate the power system reliably with higher levels of wind power penetration, where WPPs can actively participate in secondary power balance control.

In this respect, conventional market models are important to be considered as well, as they are simulating optimal UC and dispatch of power plants with one hour resolution [38]. However, in order to manage the wind power forecast errors in a large scale wind power integrated power system, a dispatch plan for the power plants with a smaller resolution than one hour is necessary. This PhD study uses an hour-ahead regulating power plan in a time scale of five minutes to compensate the real time active power imbalances in the power system. The regulating power plan is provided by the power balancing model, Simulation power balancing (SimBa), developed by the Danish TSO (Energinet.dk) together with the Technical University of Denmark (DTU).

1.3 Research objective

TSOs have the utmost task to secure the power system operation while keeping the cost at its minimum. This applies on the power systems with increasing integration of wind power, where WPPs may influence the power balance control due to wrong forecast of wind power. The intermittent nature of wind power contributes to the deviations in planned power generation which can lead to power system control and balancing problems. Traditionally, conventional power plants have the task to maintain the active power balance and are capable of meeting the TSO guidelines. However, their possible replacement in the future by WPPs of similar size increases the risk of system failures, unless the TSOs revise and set new requirements for WPPs. The TSOs of highly wind power integrated power system have to develop methods and tools to ensure the most cost effective way of integrating additional wind energy to their power systems.

This research work ‘Wind Power Plant System Services’ analyses the real-time balance control in modern Danish power system, where WPPs can actively contribute in active power balance control. The work is carried at DTU Wind Energy department in collaboration with Energinet.dk and it is funded by Sino Danish Centre for education and research (SDC).

The aim of this PhD project is to develop and analyse models and control strategies for WPPs, which increase their capability to provide system services. The focus is on active power balancing of modern power systems with high wind power penetration, where WPPs have higher capacity than conventional power plants and contribute largely to the total load demand.

Specifically, the objectives defined for this work are:

- *To study the active power balance control in a power system during normal and critical weather conditions, when wind power shares more than 50% of the total electricity consumption*
- *To study the WPPs capability to provide system services, participating in the power balance control of the power system by providing primary and secondary response*
- *To integrate the WPPs control in AGC, aiming to provide suitable active power regulation service when required*
- *To study the real-time coordination of secondary dispatch between WPP and CHP, and the overall response of the power system*
- *To study the real-time balance control when WPP and flexible consumptions respond to the AGC command*

- *To study the coordination between primary, secondary and tertiary control during different loads and production conditions*

1.3.1 Research approach

Adequate power system models and control strategies are of high relevance for power system studies, like the present one, on active power balance control. A Danish power system model is developed for this proposes as an example, taking the generation and power exchange capacities for the year 2020 into account. The developed power system model includes AGC, aggregated models for CHP, de-centralized combined heat and power plant (DCHP) and WPP and interconnections with neighbouring power system. The aggregated generating unit model reduces the computation effort but still contain the dynamic features relevant for specific studies. Long term simulations are used to study the dynamics of highly wind power integrated power system model, where its performance is assessed and discussed by means of set of simulations.

Conventional market models are simulating optimal UC and dispatch of generation units with one hour resolution, based on input time series for consumption and renewable power generation. This modelling approach reflects the mechanisms of the power trading on day-ahead spot markets. The increasing integration of wind power causes a growing need for activation of regulating power with reduced planning horizon, in order to cope with wind power forecast errors and other sources of imbalance. SimBa model generates the hour-ahead schedule in a five minutes plan for balanced power system operation. It approximates the wind power fluctuation from hour-ahead wind power forecasts within each operating hour and estimates the wind power with a five minute time resolution. Based on the estimated wind power forecast and the day-ahead power production plan from the spot market, SimBa model releases an hour-ahead regulating power plan in a time scale of five minutes for generating units and power exchange with neighbouring power systems. This study uses the regulating power plan from SimBa model as input to the power system model, where the conventional generating units, power exchange and the load uses hour-ahead plan, while WPPs generates the available power.

This research work evaluates the impact of large scale wind power penetration in a power system with wind power supplying more than 50% of the total generation, as it will be the case for Danish power system in 2020. Firstly, the work investigates how power imbalances between demand and generation, caused by wind power forecast errors, can be compensated by regulating the active power production from AGC controlled CHP. The research evaluates then the capability of WPPs to contribute in in the power balance by integrating the aggregated WPP control into the AGC system. The study shows that the coordinated secondary control between CHP and WPP enhances the reliable operation of large scale wind power integrated power system. The research work also evaluates the power system performance when an algorithm

effectively activates the regulating bids to relieve the secondary control reserves and to further minimize the power imbalance. The research work at the end investigates the power system performance when secondary control is provided by the WPPs and flexible consumption units.

1.3.2 Project limitation

The focus of this study is on active power balance control in a highly wind power integrated power system, system balance management and coordinated AGC control between CHPs and WPPs. Special attention is paid to the reserves deployment, taking the grid regulations in account. The research work studies the real-time power balance control during normal and critical weather conditions, and do not considers the power system dynamics during severe grid faults, e.g. short circuits or $N - 1$ contingency. Moreover, the study involving voltage control, transmission losses, transmission constraints and system inertia are also not the scope of this research work.

The generating units with the same technology are aggregated for this study, as the reference power provided by the SimBa model are ramped with a single rate, i.e. 30 MW/min. The aggregation of CHPs and WPPs also simplifies the secondary dispatch process, as the dispatch is decided between two generating units. An aggregated model for WPP is developed for a specific study, i.e. active power balance control and the modelling do not consider the inertial response from WPP. The power exchange on HVDC links is kept at its planned level and dynamics on AC interconnection with Nordic and CE power systems are studied with an external grid.

1.4 Contributions

The main contributions of this PhD work are listed below:

- *Implementation of Danish power system model that includes the aggregated models of CHP, DCHP and WPP, along with system interconnection and the AGC control*
- *Study of WPPs capability to contribute in active power balance control*
- *Development of coordination method between CHPs and WPP in the dispatch process for AGC*
- *Development of ‘rolling balance’ algorithm for programmed activation of regulating power bids, emulating the control room response*
- *Study and characterization of generating units for providing primary control*
- *Study and characterization of CHPs and WPPs for providing secondary control*

- *Study and characterization of flexible loads for providing secondary control*
- *Studying power system behaviour during normal and critical weather conditions, with large scale integration of wind power*

1.5 Thesis outline

The introduction chapter is followed by the main body of the thesis which is organised as follows:

The second chapter introduces the Danish power system, based on which the power system model has been developed. This chapter provides an overview of the general structure of the electrical power network in Denmark and outlines the existing and future intended capacities of generating units and system interconnections.

The third chapter briefly discusses the regulations for active power balance control and the reserve requirement in the CE and Nordic power systems and its share for the Danish power system. This chapter also highlights the specific requirement for the WPPs in Denmark, contributing to frequency control services.

The fourth chapter highlights the modelling of real-time power balance control. This chapter initially discusses the generation of hour-ahead regulating power plan from Simba model and then the modelling of AGC. A coordinated control strategy between CHPs and WPPs, where WPPs can contribute actively in active power balance control, is explained afterwards. The chapter also proposes a ‘rolling balance’ algorithm for the programmed activation of manual reserves, to reduce the sustained power imbalances and restore secondary reserves.

The modelling of the generating units and the system interconnections is discussed in the fifth chapter. This chapter explains the development of aggregated models of generating units and also evaluates their performance. The aggregated models developed for this study are neither too complex, which makes the simulations time consuming and nor too simple to reduce the results reliability. The simplified models reduce the computation effort but still contain the dynamic features relevant for the specific application.

The sixth chapter investigates through sets of simulations the long term dynamic behaviour of the power system regarding active power balance control, by utilising the developed models and control strategies described in Chapter 4 and Chapter 5. The chapter initially analyses the dynamic behaviour of the developed power system model and then the real-time power balance control in an interconnected power system, where wrong forecasts of wind power leads to huge power imbalances. The studies are based on assumptions for the year 2020 and the time series for generation, load and power exchange are provided by SimBa model. This chapter analyses

the contribution of WPPs and flexible consumption units in the power balance control, along with conventional power plants.

The final chapter summarizes the conclusions of this thesis with discussions and the recommendation for future work.

1.6 List of publications

- P 1: Basit A.; Hansen A. D.; Altin M.; Sørensen P.; Gamst M.: 'Wind power integration into the automatic generation control of power systems with large-scale wind power', The Journal of Engineering, 1 (1), DOI: 10.1049/joe.2014.0222, IET Digital Library, <http://digital-library.theiet.org/content/journals/10.1049/joe.2014.0222>
- P 2: Basit A.; Hansen A. D.; Altin M.; Sørensen P.; Gamst M.: "Compensating Active Power Imbalances in a power system with high wind power penetration" Submitted to Journal of modern power system and clean energy
- P 3: Basit A.; Hansen A. D.; Altin M.; Sørensen P.; Giannopoulos G, "Real-time impact of power balancing on power system operation with large scale integration of wind power" Submitted to Journal of modern power system and clean energy
- P4: Basit A.; Hansen A. D.; Altin M.; Sørensen P.: "Analysis of Highly Wind Power Integrated Power System model performance during Critical Weather conditions", Wind Integration Workshop (WIW), Berlin, 2014
- P5: Basit A.; Hansen A. D.; Altin M.; Sørensen P.: "Balancing modern Power System with large scale of wind power", China Wind Power (CWP), Beijing, 2014
- P 6: Basit A.; Hansen A. D.; Sørensen P.: "Dynamic model of frequency control in Danish power system with large scale integration of wind power", China Wind Power (CWP), Beijing, 2013
- P7: Basit A.; Hansen A.D.; Margaris I.D.; Hansen J.C., "A Review of Grid Requirements for Wind Farm in Denmark and China", China Wind Power (CWP), Beijing, 2012

Chapter 2

Danish power system

This chapter provides an introduction to the Danish power system, starting with an overview of the general structure of electrical power network in Denmark, i.e. Eastern and Western Danish power systems. The chapter then outlines the existing and future interconnections of the Danish power system with the Nordic and CE power systems and also the great belt link connection between the two Danish electrical networks. The main part of this chapter is devoted to power generating units, where various types of generating units in the Danish power system are summarized. The conventional power generation is basically from CHPs and DCHPs, while renewable power generation from WPPs. The chapter also provides an overview of the existing and future intended capacities of the generating units in Denmark.

2.1 Danish power system overview

Danish power system is electrically divided into two parts, Eastern and Western Danish power systems. The Eastern Danish power system is synchronously connected to the hydro power dominated Nordic synchronous power system and the Western Danish power system to the fossil fuel dominated CE synchronous power system. The Eastern and Western Danish power systems are connected through a High Voltage Direct Current (HVDC) link, called the ‘Great Belt power Link’ (GBL). The HVDC links also connects Eastern Danish power system to CE power system and Western Danish power system to Nordic power systems. The electrical interconnections of the Danish power system with neighbouring power systems is shown in Figure 3, where the blue lines showing the HVDC connection and red lines showing the AC connection.

2.1.1 Eastern Danish power system

The Eastern Danish power system includes Zealand and some nearby small islands. The electrical power is generated mainly from CHPs, DCHPs and WPPs. The CHPs and DCHPs uses coal, gas, oil, waste and bio mass as a fuel for the production of electricity and heat, while WPPs are spread on land (onshore) and also located in sea (offshore). The transmission system comprises overhead lines and cables at the two highest voltage levels of 132 kV and 400 kV [39].

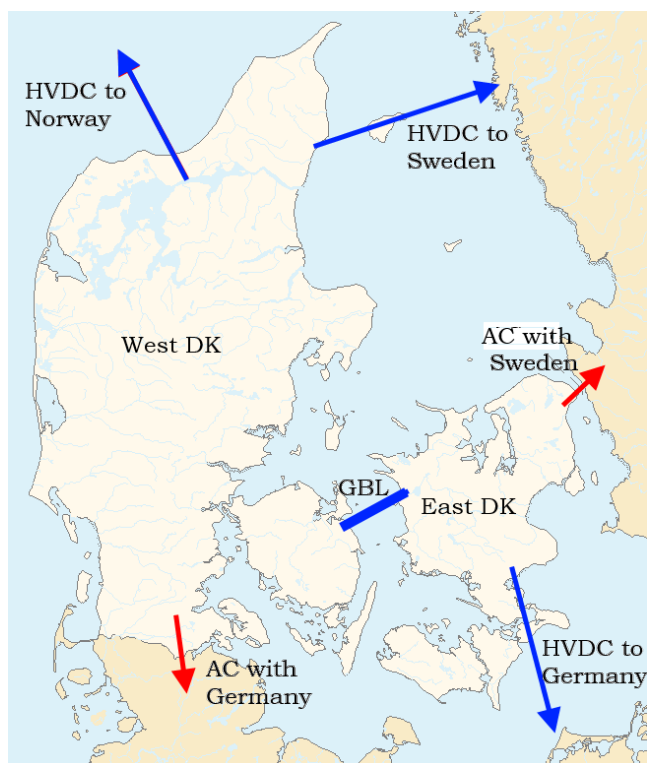

Figure 3: Danish power system interconnections with Nordic and CE power systems; Red lines indicate the AC connection and the blue lines indicate the HVDC connection

The Eastern Danish power system constitutes the southern part of strong Nordic power system. The Nordic power system is characterized by large hydro power that comes from Norway [39]. The predictable power generation from hydro power stabilizes the frequency of Nordic power system. This is of great profit for the Danish Eastern system, as the power balancing task is more difficult with large scale integration of wind power. The strong Nordic power system makes the power system operation in the Eastern Denmark frequency stable. In the south, the Eastern Danish power system is also connected to Germany, the CE power system, with an HVDC link.

2.1.2 Western Danish power system

The Western Danish power system includes Jutland, Funen and some small islands. The Western Danish power system also generates the electricity from CHPs, DCHPs and WPPs. The conventional generation uses coal, gas, waste and Bio mass as fuel for the production of electricity and heat. A significant portion of the power generation comes from onshore and offshore WPPs. The electricity is transmitted through overhead lines and cables at the highest voltage levels of 150 kV and 400 kV [39].

The Western Danish power system is interconnected to CE power system through Germany in the south, where fossil fuelled power plants are dominating. The CE power network has large inertia and offers huge automatic frequency response, making the Western Danish power system

frequency stable with large scale integration of wind power. The Western Danish power system is also connected to Nordic power system through HVDC links via Norway and Sweden.

2.2 System Interconnections

As aforementioned, the Danish power system is comprised of two parts, i.e. Eastern and Western Danish power systems. The Eastern and Western Danish power systems are connected through GBL and also interconnected to the strong neighbouring power systems of Germany, Sweden and Norway. Figure 3 shows the interconnections of the Danish power system and are briefly explained below:

2.2.1 Great Belt Link

An HVDC connection having a transmission capacity of 600 MW connects the two electrical networks of the Danish power system [40, 41]. The HVDC link, shown in Figure 3, has a voltage level of 400 kV. The converter station on Western Denmark side is connected to a 400 kV substation and the converter station on Eastern Denmark side is connected to a 400 kV overhead line. The GBL interconnector includes 32 km long sea cable, 16 km long land cable in Western Denmark and 10 km long land cable in Eastern Denmark. The interconnection was commissioned in July 2010 and started commercial operations in August 2010 [41].

2.2.2 Eastern Danish power system interconnections

The Eastern Danish power system is connected to Sweden through an AC transmission line and with Germany through a HVDC transmission line, shown in Figure 3. The interconnection to Sweden, i.e. link to the Nordic grid, is through two 400 kV and two 132 kV cables connections, having a total capacity of about 1700 MW [40]. Eastern Denmark is connected to Germany through a 400 kV DC cable with a capacity of 600 MW [40].

2.2.3 Western Danish power system interconnections

The Western Danish power system is connected to Sweden and Norway through a DC connection and to Germany through an AC connection. The interconnection to Sweden is through two 250 kV DC connections with a transmission capacity of 740 MW [40], while the interconnection to Norway comprises of three DC connections, two 250 kV and one 350 kV, with a total transmission capacity of 1040 MW. According to [42, 43], a planned fourth electric cable to Norway will increase the transmission capacity from 1040 MW to 1640 MW. Moreover, the Danish and Dutch TSOs are also planning to build a DC power link with a capacity of 700 MW which is expected to be operational by 2016 [44].

As mentioned, an AC interconnection with Germany links the Western Danish power system to the CE grid. It consists of four AC connections, i.e. one 400 kV, two 220 kV and one 150 kV

connection. The total transmission capacity on this AC connection at present is approximately 1500 MW [40]. Though, according to [43], there are plans to increase this transmission capacity to 2500 MW by 2017. The planned system interconnections for the future Danish power system with Nordic and CE power systems is shown in Figure 4, with AC as dotted line and DC as bold line.

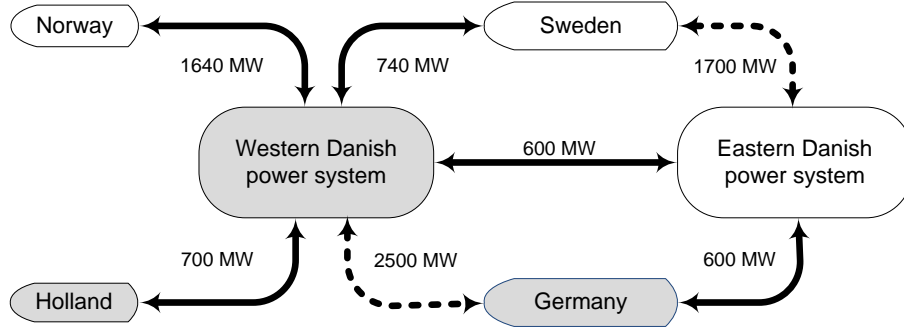

Figure 4: Planned system interconnection capacities for future Danish power system with neighbouring power systems

It is worth mentioning that, Denmark’s neighbouring power systems ramp the agreed power exchange in different durations and at different starting times [14]. For example, in the Nordic power system, the agreed power exchange shall be ramped within 30 minutes and shall begin 15 minutes before the agreed exchange hour. Meanwhile, in the CE power system, the power exchange shall be ramped within 10 minutes and shall start 5 minutes before the agreed exchange hour. The difference in power exchange ramping might lead to a power imbalance in Danish power system at an agreed hour. For example, if the power has to be transported from the Nordic power system to the CE power system or vice versa, it might end in a power surplus or deficit in the Danish power system, respectively. The Danish TSO deals with the power imbalance on an agreed exchange hour by activating an extra regulating power bid, to maintain active power in balance.

2.3 Electrical power generation

The electrical power generation in Denmark is a combination of conventional and renewable generation sources. The conventional power generation is typically based on centralized thermal power plants and DCHPs, while renewable generation is mainly from WPPs. Most of the centralized thermal power plants are also used for the production of heat along with electricity generation and therefore in this study they are classified as centralized CHPs. The following will present the CHPs, DCHPs and WPPs operating in the Danish power system.

2.3.1 Conventional power plants

CHPs are globally popular for their most efficient ways of generating electricity and heat, with lower CO₂ emissions compared to other fossil fuelled power plants. The co-generation of electricity and heat enables the efficient utilisation of fuel. Large amount of heat is wasted in conventional way of electricity generation, whereas the CHP captures usable heat in an efficient way and utilize it either for district heating or for electricity production through steam turbine. Thus, the reuse of heat increases the efficiency of CHP power plants.

The EU has actively incorporated cogeneration in its energy policy and Denmark is among one of the countries that have employed intensive cogeneration in its generation system. The combined production of heat and power saves a minimum of 10% of energy compared to separate production [45]. According to [46], Denmark with modern equipment saves 25 – 30 % of the energy with cogeneration. Denmark has both large scale CHPs and small scale DCHPs in its generating system. CHPs are located in large cities, while DCHPs are located at smaller centres. 16 CHPs and approximately 415 DCHPs supply public heating in Denmark [47]. Most of the CHP in Denmark are coal fired while DCHP typically uses natural gas, waste, biomass or bio gas as a fuel [48]. The CHPs operating presently in the eastern and western Denmark are discussed below and shown in Figure 5. The CHPs are marked as red dots while the DCHPs as yellow on the Danish map.

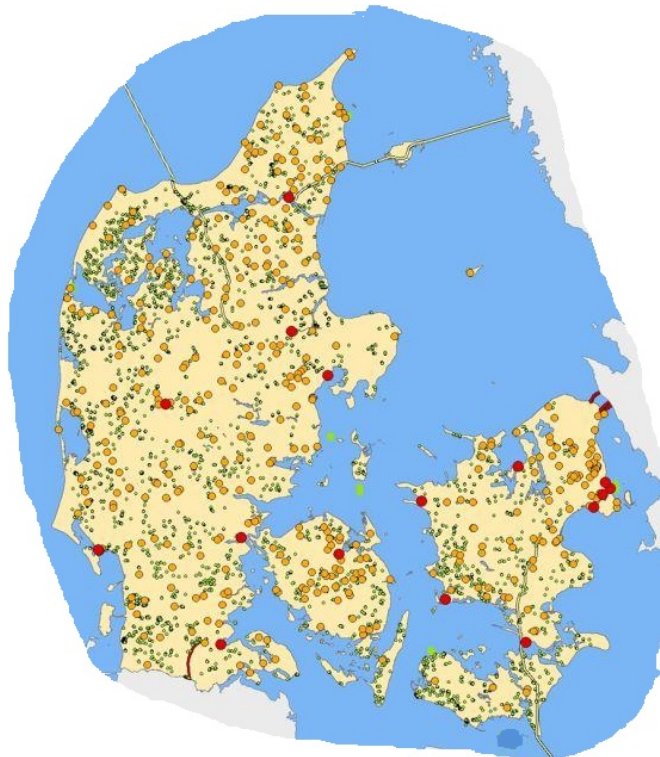

Figure 5: CHPs and DCHPs in the Danish power system

The CHPs operating centrally in Danish power system are briefly explained below, with their capabilities of generating electricity and heat and also the type of fuel they used [48, 49]. The CHPs operating centrally in Eastern Denmark are as follows:

- **Asnæs Power Station** (*Asnæsværket*) can deliver a total of 782MW electricity and up to 552MJ/s of heating for the Municipality of Kalundborg. The Asnæs Power Station uses coal as its main fuel and oil as a reserve.
- **Avedøre Power Station** (*Avedøreværket*) utilises up to 94 % of the energy in the fuels by producing electricity and heat simultaneously. The total production capacity is 793MW electricity and 918MJ/s heating. The Avedøre Power Station supplies 200,000 households with heat. It consists of two power station units: Avedøre 1 and Avedøre 2. Avedøre 1 primarily uses coal as fuel and Avedøre 2 is a multi-fuel system, which utilises natural gas, oil, coal, straw and wood pellets.
- **H.C. Ørsted Power Station** is a gas-fired power station that can generate 98MW of electricity and 486MJ/s for district heating. The primary task is to supply district heating to the Copenhagen district heating network.
- **Kyndby Power Station** is the emergency and peak load facility for Zealand in Hornsherred. It can start operating within minutes in case of operational irregularities. The 734MW capacity is distributed on five different production units; 260MW on two oil-fired steam power units, 63MW on two oil fired gas turbine units and a 70MW on gas turbine.
- **Amager power station** is fuelled with coal and bio pellets and comprises of two combined heat and power units with a combined electrical capacity of 314 Megawatt and a combined heat capacity of 583 MJ/s.
- **Stignæs Power Station** consists of two coal-fired production plants with an overall capacity of 409 MW of electricity and 2 MJ/s of heat.

Also, the CHPs operating in Western Danish power system are:

- **Esbjerg Power Station** has a total capacity of 371MW electricity and 460MJ/s of heating. The power station primarily uses coal to produce electricity and district heating.
- **Herning Power Station** based on biomass fuels produces 88MW of power and 200MJ/s of district heating. It burn wood chips and wood pellets, with natural gas as reserve fuel. Wood chips make up about 70% of fuel while wood pellets approximately 30 %.

- **Skærbæk Power Station** has a capacity of 392MW electricity and 447MJ/s heating. It is a natural gas fired plants with a total efficiency of 49 % at 100 % power production. At combined heat and power production, the plant can achieve a total efficiency of 93 % which makes it one of the world's most efficient power stations.
- **Studstrup Power Station** is located north of Aarhus and has a total capacity of 714MW electricity and 986MJ/s district heating. Studstrup Power Station primarily uses coal for generating electricity and district heating.
- **Fyn Power Station** (Fynsværket) is a coal, straw and municipal waste-fired power station in Odense, having a generation capacity of 675 MW of electricity.
- **Ensted Power Station** (Enstedværket) is a thermal power plant in Aabenraa, Denmark. The power station is fuelled by coal, straw and woodchips and has a generation capacity of 700 MW.
- **Nordjylland Power Station** (Nordjyllandsværket) is a coal-fired combined heat and power plant in the north east of Aalborg, Denmark. The power plant has the generation capacity of 741 MW.
- **Viborg Power Station** (Viborg Kraftvarmeværk) is a natural gas-fired power station. It can provide 57 MW of electric power and 57 MJ/s of district heating.

Apart from centralized power plants, large numbers of dispersed generations in form of DCHPs is also installed in the Danish electricity system, as shown in Figure 5. DCHPs are characterized by the connection between local district heating system and a regional power grid. As aforementioned, these power plants mainly use natural gas for the production of heat and electricity. The other sources of generation are waste, oil, coal and bio mass. The DCHPs deliver heat to the local district heating system and are equipped with heat storage tank, so they can operate more independently from the heat demand. DCHP units with a capacity of less than 10MW are operated in on-off mode depending on the power prices they are given. Units above 10MW are allowed to participate in power balancing through electricity market [50]. In this study, the DCHP units only offer spinning reserve for real-time balance control.

During last decades, the Danish power system has evolved from fossil fuel to environmental friendly mix of renewable energy, generated 33.2% of the annual electricity consumption from the wind power in 2013 and aims to increase it to 50% by 2020. In view of future ambitious goal, Table 1 provides the future intended power generation from conventional power plants by the Danish TSO in the Eastern and Western Danish power system.

Table 1: Future intended Conventional power generation in Danish power system

	DCHP		CHP	
	Fuel	Generation capacity (MW)	Fuel	Generation capacity (MW)
Eastern Danish power system	Bio Mass	124	Coal	1166
	Coal	35	Gas	560
	Gas	624	Oil	692
	Waste	96	Internal Combustion	20
	Oil	34	-	-
Western Danish power system	Bio Mass	193	Bio Mass	350
	Waste	154	Coal	1130
	Gas	1261	Gas	436

From Table 1, DCHP power plants mainly use gas for energy production, while CHP power plants use coal as a fuel.

2.3.2 Wind Power Plants

Denmark, being a pioneer in generating the electricity from wind is characterized today by the highest wind power penetration level in Europe. The installed wind power capacity reaches to 4792 MW in 2013 [3]. This large scale integration of wind power provided 33.2% of the total electricity generation in Danish power system. The electricity is generated from both onshore and offshore WPPs in Danish power system. The onshore WPPs have the capacity of 3521 MW and are geographically distributed in whole Denmark [51]. A large geographical spread of onshore wind power reduces the power variability and increases the predictability of output power [52]. On the other hand, the power fluctuations are much more intense from off shore WPPs having the capacity of 1271 MW [51]. The offshore wind farms operating presently in Denmark are listed in Table 2 and some of them are briefly described below.

- *Anholt offshore wind farm with a capacity of 400 MW is the largest wind farm in Denmark and third largest offshore wind farm in the world. The wind farm has 111 number of wind turbine of 3.6 MW. The wind farm is commissioned in September 2013 and is located between Djursland and Anholt island.*
- *Horns Rev 2 is located in the eastern North Sea, about 30 km off the westernmost point of Denmark, Blåvands Huk. It consists of 91 wind turbines with a capacity of 2.3 MW. The total generating of Horns Rev 2 is 209 MW.*
- *Nysted (Rødsand 1) and Rødsand 2 are located close to the Rødsand sand bank near Lolland. Rødsand I was built in 2003, with 72 turbines and a total capacity of 166 MW.*

In 2010, a 207 MW extension of the Nysted wind farm as Rødsand 2 was installed. Rødsand 2 consists of 91 wind turbines.

- **Horns Rev** located close to Horns Rev 2 in the eastern North Sea, about 15 km off the Blavands Huk. This offshore wind farm has a generating capacity of 160 MW with a total of 80 wind turbines (2 MW).

Table 2: Offshore Wind farms in Danish power system

Wind Farm	Capacity (MW)	Number of wind turbine
Anholt	400	111
Horns Rev 2	209	91
Rodsand 2	207	90
Nysted (Rodsand 1)	166	72
Horns Rev 1	160	80
Middelgrunden	40	20
Samsø	23	10
Sprogo	21	7
Ronland	17.2	8
Avedøre Holme	10.8	3
Frederikshavn	7.6	3
Tuno Knob	5	10
Vindeby	4.95	11

The Danish power system will increase the country's offshore wind capacity by 1500 MW in coming years, to attain the 2020 goal. The 1500 MW will be achieved by constructing the offshore wind farms; Horns Rev 3 with a capacity of 400 MW and Krigers Flak with a capacity of 600 MW [53]. Horns Rev 3 will start operating in 2017, while Kriger Flak is set to be fully operational by 2020. 450 MW will be provided from near shore wind farms along with 50 MW of experimental offshore wind farms [53]. Furthermore, 500 MW of additional capacity will be achieved by scraping 1300 MW of outdated on shore wind turbines and simultaneous building of 1800 MW of modern wind turbines [2]. With the effect of commissioning new wind farms, the installed wind power capacity will be upgraded to 6600 MW, i.e. 2800 MW in Eastern Danish power system and 3800 MW in Western Danish power system. Figure 6 shows the existing and future offshore wind farms in Denmark that would be operational by 2020.



Figure 6: Present and future off shore wind farms in Denmark

2.4 Summary

Increasing wind power integration significantly affects the secure operation of power system. The large scale wind power integration brings challenges like power regulation, frequency stability and voltage stability along with UC, ED and AGC.

An overview of the Danish power system and its general structure is presented and discussed in the chapter. The Eastern and Western Danish power systems are strongly connected to the neighbouring countries of Nordic and CE powers systems offering huge frequency response. This chapter provides an overview of the existing and future intended power exchange capacities with strong neighbouring power systems that stabilize the system frequency. However, power balance is still one of the main challenges that need to be evaluated for large scale integration of wind power. This chapter also highlights the conventional and wind generating units in the Danish power system and also presented the intended future generating plans for the Danish power system.

Chapter 3

Technical requirements and regulations for active power balance control

Large scale integration of wind power brings new challenges to the power system operation, raising serious concerns over its dynamic security, stability and reliability. These new challenges have already resulted in grid codes revision and established new regulations and technical requirements for reliable and secure power systems operation. As aforementioned, Denmark, being a pioneer in generating the electricity from wind is also the first to face challenges due to large scale integration of wind power. Therefore, this chapter highlights the technical requirements and the regulations for active power balance control in Danish power systems and also utilize it for further studies.

The chapter initially presents the real-time approach for active power balance control in an interconnected power system, primary frequency response during power imbalance and the AGC response from the control area causing the power imbalance. It then defines the different types of reserves used in Danish power systems and its requirement by the European Network of Transmission System Operators for Electricity (ENTSO-E) for balanced power system operation. The chapter also highlights the specific requirements for the WPPs from the Danish grid operator.

3.1 Regulations for active power balance control

Active power regulation services are typically needed to deal with the power imbalance due to forecasting error (wind power or load) or contingency events (e.g. tripping of a generating unit or network disconnection). A balance between production and consumption of electricity must always be maintained in a power system. A change in active power balance alters the system frequency and if this violates a strictly predefined frequency range it can threaten the stability and thus the security of the power system. The frequency of electric power system is determined from the relationship between generation and load demand. This relationship is exemplified in Figure 7 using the analogy of water level in a tank. The water inflow to the tank is assumed as power generation, water outflow as the system load and the water level as system frequency. If

the water inflow and outflow are equal, the water level remains balanced (frequency stable at 50 Hz). The water level rises if inflow is higher or decreases if outflow is higher, i.e. frequency will rise if generation exceeds load and will decrease vice versa. If the balance between generation and load is not maintained, the frequency will not return to nominal level.

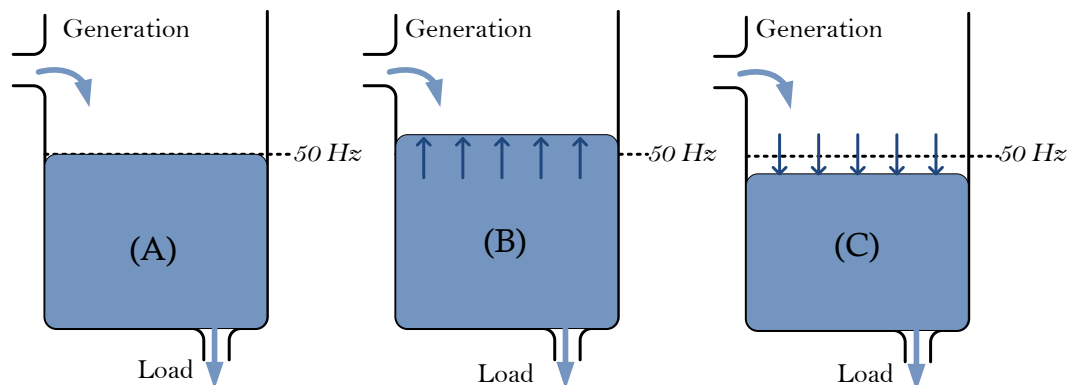

Figure 7: The concept of system frequency explained using the analogy of water level in a tank

Steady state frequency is an indication that the generation and the consumption are in balance. The frequency in a power system is typically maintained within a range specified by the system operators. Several warnings are activated in the power system if frequency starts to deviate from this range. The deviation may be due to the wrong forecast of wind power or load, or due to some contingency events that includes tripping of transmission line, transformers, generators or loads. The contingent event, like tripping of small power plant, may not risk the secure power system operation. However a large power imbalance can be a threat for operational security, as it might initiate tripping of load and generating units and the cascading events may lead to a black out situation. The critical weather conditions, e.g. high wind speeds, if not forecasted can also lead to large power imbalances in a highly wind power integrated power system, as it can result in a significant loss of wind power in a very short time (minutes) [13].

To deal with the real-time power imbalances, the inertia and frequency response from the synchronous power system together with the secondary and tertiary control is required for secure power system operation. In case of a power imbalance, the total system inertia which is equivalent to the sum of the angular momentum (rolling inertia) of all generators and spinning loads directly connected to the synchronous system resists the change in the system frequency. Afterwards, the generating units equipped with speed governors and the frequency dependent loads stabilize the frequency to a steady state level. The response depends on the power frequency characteristics of the power system and is denoted by ' β '. Afterwards, the secondary control restores the system frequency back to its nominal level. Figure 8 illustrates the above mentioned power frequency control during imbalances, where primary control is provided in 30 seconds and secondary control in 15 minutes.

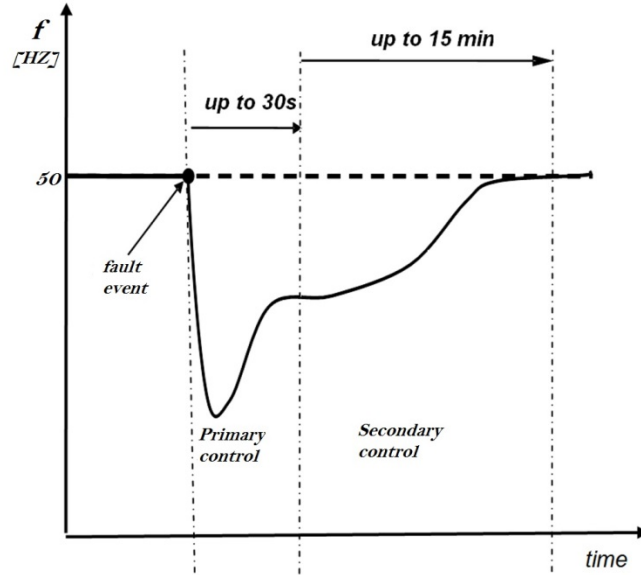

Figure 8: System frequency following power imbalances

3.1.1 Primary control

The objective of primary control is to maintain a balance between generation and consumption within the synchronous area. It is an automated response from fast generating units and is used to avoid frequency abnormality in case of a power imbalance in the synchronous power system. The primary control does not restore the system frequency but stabilizes it to a stationary value, thereby enhancing the operational reliability of the power system. This automated frequency response depends on the power frequency characteristics of the electrical network.

I. Network power frequency characteristics (β)

The network power frequency characteristics, i.e. frequency response of synchronous power system ' β ' decides the steady state change in system frequency (Δf_{ss}) after a power imbalance of ΔP :

$$\Delta f_{ss} = -\frac{\Delta P}{\beta} \quad (1)$$

The frequency response ' β ' is normally expressed in MW/Hz and is also referred to as the stiffness of the system. The response depends on the load damping constant (D) of frequency sensitive loads and primary response from the generating units equipped with speed governors. The frequency response from the generating units (β_{PS}) is the combined effect of the droops (R_{PS}) of all operating generating units equipped with speed governors, their nominal power and nominal system frequency:

$$\beta_{PS} = \frac{P_{n,PS}}{R_{PS} \cdot f_n} \quad (2)$$

$$\gg \frac{1}{R_{PS}} = \frac{\sum_{i=1}^{N_{units}} \frac{P_{n,i}}{R_i}}{\sum_{i=1}^{N_{units}} P_{n,i}} \quad (3)$$

where, R_i represent the droop of the generating unit 'i' and $P_{n,i}$ represent its nominal power. N_{units} is the number of generating units in the power system taking part in the primary response. The power system has a higher frequency response if larger numbers of generating units are operating in a power system, as the case of large interconnected power system. This means that an interconnected power system will experience less frequency deviation even for a large power imbalance.

The equivalent droop R_{PS} equals to one individual droop R , if each generator in the power system shares the same droop setting. The frequency response β_{PS} can then be simplified as:

$$\beta_{PS} = \frac{P_{n,PS}}{R \cdot f_n} \quad (4)$$

Otherwise, the total frequency response of the power system β_{PS} equals to the sum of frequency response of the individuals generating unit ($\beta_{g,i}$) operating in the power system.

$$\beta_{PS} = \sum_{i=1}^{N_{units}} \beta_{g,i} \quad (5)$$

The β_g reflects the power frequency characteristics of the generating unit, i.e. if the frequency response of a unit is 100 MW/Hz; it means that the unit is able to change its power production with 100 MW for a change in frequency of 1 Hz. The response depends on the governor droop setting, nominal power of the generating unit and the nominal system frequency, i.e.:

$$\beta_g = \frac{P_n}{R \cdot f_n} \quad (6)$$

The generating unit responds to the frequency deviance through a frequency control droop loop, where the droop settings of speed governors affect the overall response. The following will explain the effect of governor droop setting on the frequency behaviour of the power system.

II. Governor droop settings

Droop (R) of a speed governor is a relation between the system frequency and the power, which can be delivered by a generating unit into the system in case of frequency deviance from its nominal level. The droop is defined as the percentage of the frequency change required for a governor to move a unit from no-load to full-load or vice-versa. For example, a 4% droop mean that a 4% of frequency deviation causes a 100% change in the power output of the generating unit.

The contribution of a generator to the correction of frequency deviation depends mainly upon the governor droop and the primary reserves. Figure 9 illustrates the steady state droop characteristics of a speed governor, where the power of the generating unit slides back and forth

along the droop curve in an attempt to stabilize the system frequency. The droop decides the change in power (ΔP) from its set point based on the frequency deviation (Δf) from its nominal level:

$$\beta = -\frac{\Delta P}{\Delta f} \quad (7)$$

The generating unit response during power imbalances depends on (6) and (7). From these equations, the mathematical expression for the droop R can be obtained as:

$$\frac{P_n}{R \cdot f_n} = -\frac{\Delta P}{\Delta f} \rightarrow \frac{1}{R} = -\frac{\Delta P/P_n}{\Delta f/f_n} [\%] \quad (8)$$

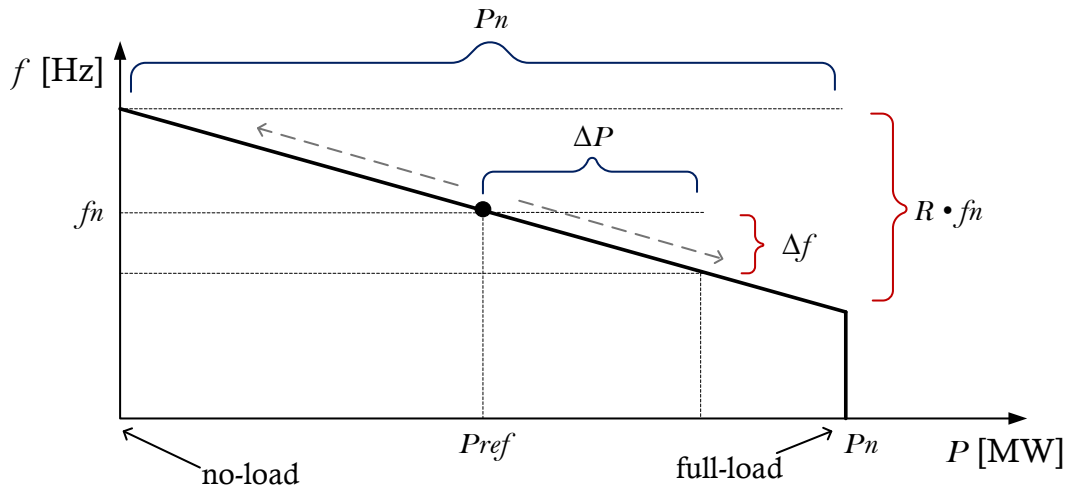

Figure 9: Droop characteristics of a generating unit

In the above figure, the nominal power (P_n) of the unit is the maximum power which can be continuously produced by the generating unit and corresponds to full load condition. While, the power set point (P_{ref}) is the power delivered by the generating unit at nominal frequency (f_n). The droop R decides the change in power (ΔP) from its set point based on the frequency deviation (Δf) from its nominal level. The generating unit response depends on the nominal power P_n of the generating unit and its operating point.

The droop setting affects the response of the generating unit, i.e. higher the droop of the generating unit, the less it will respond to frequency change (Δf), as shown in Figure 10. If two generating units, having same nominal power but different droop settings, are operating in parallel then the generating unit with high droop (R_2) responds with lesser change in production than the generating unit with a smaller droop (R_1), for the frequency change of Δf .

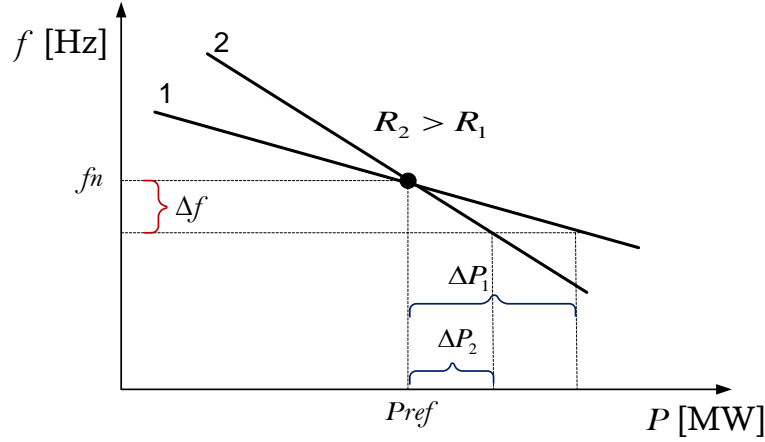

Figure 10: Effect of changing droop settings

Thus, the amount of load sharing between the two parallel generators having different droop settings will be:

$$\frac{\Delta P_1}{\Delta P_2} = \frac{R_2}{R_1} \quad (9)$$

As illustrated in Figure 8, that during primary control, the frequency in the system does not return to its initial steady state. In order to force the frequency to return to the initial steady state, the generating units have to participate in the secondary control by assigning new power set point. This will shift the droop characteristic of the unit as it has to produce more at the same frequency, as shown in Figure 11. Therefore, in addition to the other parameters, the power set point (P_{ref}) is also essential to describe the behaviour from the generating unit during power imbalance.

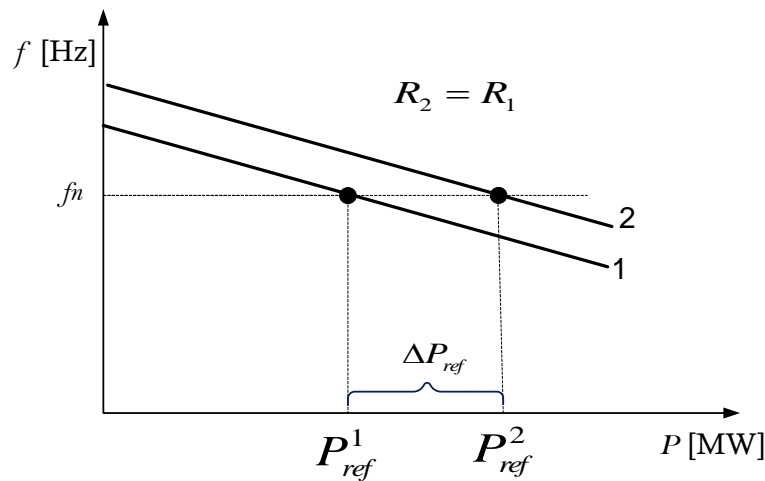

Figure 11: Effect of changing reference set point on primary response

The generating unit is unable to respond to negative frequency deviation, if it is operating at full load (P_n) and vice versa if operating at minimum level.

3.1.2 Secondary control

The control areas within the synchronous power system provide the primary response following power mismatch between generation and load demand. The primary response stabilizes the system frequency at a new level and the response from the interconnected power system deviate the power exchange between the control areas from its schedule. To restore the system frequency and the power exchange, the secondary control action is required from the generating units in the control area where power imbalance occurred. The secondary control regulates the power set points of the set of generating units to restore the power balance in that control area. This will restore the system frequency to its nominal level (50 Hz) and the power exchanges to its schedule. The secondary control will also ensure the re-availability of primary reserves in the power system, initially activated in response to power imbalance.

Secondary control is much slower than primary control and is therefore timely dissociated. The secondary control operates for periods of several minutes and will be made either with AGC systems or via manual intervention by the system operators. The automatic secondary control, i.e. with AGC, continually respond to the power imbalance due to forecasting error (wind power or load) or contingency events (e.g. tripping of a generating unit or network disconnection). The AGC is intended to balance the power system by managing the response of available resources within minutes as opposed to primary frequency response, which manages response within seconds. The AGC reduced the power imbalances using area control error (P_{ACE}) as input signal. It results due to the power mismatch between generation and load demand, and is the sum of the power control error and the frequency control error:

$$P_{ACE} = -(\Delta f \cdot B) - \Delta P_{exchange} \quad (10)$$

$$\rightarrow \Delta f = f_{actual} - f_{nominal} \quad (11)$$

Power control error ' $\Delta P_{exchange}$ ' is the residual power imbalance of the control area which appears as a deviation on AC interconnections from its exchange schedule. The ' $\Delta P_{exchange}$ ' can also be calculated as:

$$\Delta P_{exchange} = \sum P_{schedule} - \sum P_{actual} \quad (12)$$

It is worth mentioning that in this study, the power flow from the control area indicates the export power and appear as load, whereas power flow into the control area indicates import power and will appear as negative load or generation.

Frequency control error ' $\Delta f \cdot B$ ' is the product of frequency deviation and frequency bias settings of the AGC system. The frequency bias B is used to account for the power changes associated with power frequency characteristics (β), i.e. primary frequency response, of the control area and to prevent premature withdrawal of generator response as long as frequency returns to its nominal level. The bias B shall not be confused with response β , although both are

measured in MW/Hz [54]. β represents the actual MW primary response contribution to stabilize frequency following power mismatch, while B used in the ACE equation is an approximation of β . The β changes in accordance with operating generating units and thus it might be imagined that bias B for the secondary control should also be adjusted regularly. However, the bias B is kept constant to avoid any discrepancies due to the real-time uncoordinated adjustments in an interconnected power system.

The P_{ACE} in the AGC system replicates the power imbalance (opposite) in the control area, if frequency bias settings B equal to the power frequency characteristics of the generating units providing the primary response in the control area. A positive load step will result in a negative power imbalance and hence require an increase in the secondary power. The P_{ACE} must be kept close to zero in each control area that can be achieved by reducing the power control error and frequency control error to zero.

The desired behaviour of the AGC over time will be obtained by assigning a proportional integral (PI) characteristic to control circuits, i.e.

$$\Delta P_{sec} = K \cdot P_{ACE} + \frac{K}{T} \int P_{ACE} \cdot dt \quad (13)$$

where,

ΔP_{sec} is the required secondary response

K is the proportional gain of the PI controller

T is integration time constant of the PI controller

P_{ACE} is the area control error of the imbalanced control area

Appropriate parameters for K and T are needed for the secondary controller to return the system frequency and the power exchange to their set point values. Parameter settings for secondary controllers in an interconnected power system follow a common guideline to ensure co-operative secondary control within the synchronous area. According to [55], at present in CE power system, typical values ranging from 0 to 0.5 are used for tuning the proportional term (K) and values ranging from 50 seconds to 200 seconds are used for tuning the integral time constant (T) of the secondary controller. ‘ T ’ represents the tracking speed of the secondary controller which activates the control power from participating generators.

Illustrating primary and secondary response with an example

For better understanding, an example illustrates the sequence of power balancing events in an interconnected power system following a power mismatch between generation and load. In this example it is assumed that the interconnected power system consists of two areas, the control area

where power imbalance occur and the rest of the power system. The two areas are connected by tie-lines, as shown in Figure 12.

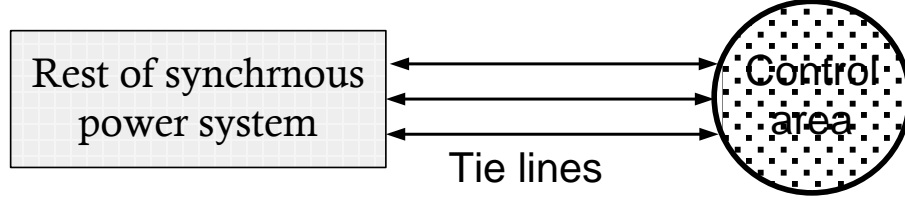

Figure 12: Interconnected power system presented as two areas

Before disturbance, it is assumed that the power system is perfectly balanced, such that the actual frequency of the power system equals to the nominal frequency and the tie line power exchange is at its schedule, i.e. Δf and $\Delta P_{\text{exchange}}$ are zero.

Let us suppose that, a power mismatch of P_a appear between generation and load demand in control area. This mismatch is initially stabilized by the primary response from the overall power system, thus resulting in a new steady state frequency ' $f_{\text{nominal}} + \Delta f_{ss}$ ' and power deviation ' $\Delta P_{\text{exchange}}$ ' on tie-lines from its schedule. The change in frequency ' Δf_{ss} ' depends on the power frequency characteristics of interconnected power system (β):

$$\Delta f_{ss} = -\frac{P_a}{\beta} \quad (14)$$

The primary response ' β ' is the sum of primary response from the control area (β_1) and the rest of power system (β_2). In response to the Δf_{ss} , the control area modifies its production by ΔP_1 and the rest of power system by ΔP_2 , i.e.:

$$\Delta P_1 = -\beta_1 \cdot \Delta f_{ss} \quad (15)$$

$$\Delta P_2 = -\beta_2 \cdot \Delta f_{ss} \quad (16)$$

$$\rightarrow \Delta P_1 + \Delta P_2 = P_a \quad (17)$$

Thus, the primary response from the control area and the rest of power system will provide the power equal to the power imbalance (P_a) and stabilizes the system frequency at new level. Also from (17), the generation increases if P_a is the positive load step and vice versa. The primary response from the rest of power system (ΔP_2) will appear as negative deviation ($\Delta P_{\text{exchange}}$) on the tie lines from its scheduled exchange, i.e. $\Delta P_{\text{exchange}} = -\Delta P_2$.

To return system frequency to its nominal level and tie-line exchange to its schedule, the secondary controller within the control area will activate the secondary power from the generating units. The secondary controller will calculate the area control error ' P_{ACE} ' according to (10), where power control error is the deviation from scheduled exchange and the frequency control error equals to the primary frequency response from the control area, if frequency bias settings ' B ' equals to the power frequency characteristics of the control area (β_1):

$$P_{ACE} = -(\Delta f_{ss} \cdot \beta_1) - \Delta P_{exchange} \quad (18)$$

$$\rightarrow P_{ACE} = \Delta P_1 + \Delta P_2 = P_a \quad (19)$$

The PI controller in the control area then provides secondary response by dispatching the generating units in the control area, as shown in (13). The secondary control action will offset the power imbalance, such that the Δf and $\Delta P_{exchange}$ associated with the power imbalance P_a will be restored to zero.

The secondary reserves are restored with *tertiary control*, which not only guarantees the availability of secondary reserves but also economically re-distributes the required power among various generators in best possible way. The TSOs shall ensure that adequate reserves are always available for maintaining power balance in the power system and sufficient transmission capacity to accommodate these standby reserves. Apart from the reserves requirements, the TSOs also enforced certain regulation on the generating units connected to the power system.

3.2 Requirement for balancing reserves

The real-time operational management requires actions, of the ancillary services, by the system operators for the balanced power system operation. The ancillary services in form of reserves maintain the power balance control as described in the above section. A power system should always have excess rotating capacity in order to be able to compensate for power imbalances and to keep the frequency of the system within allowable limit.

The reserves required during real-time operation by the ENTSO-E for the primary, secondary and tertiary responses are categorized correspondingly as Frequency Containment Reserve (FCR), Frequency Restoration Reserve (FRR) and Replacement reserve (RR) and are defined as follows [56, 19, 57]:

Frequency Containment Reserve (FCR) are operating reserves necessary for constant containment of frequency deviations (fluctuations) from nominal value in order to constantly maintain the power balance in the whole synchronously interconnected system. Activation of these reserves results in a restored power balance at a frequency deviated from its nominal value. This category typically includes operating reserves with the activation time up to 30 seconds (up to 2-3 minutes in Nordel). Operating reserves of this category are activated automatically and locally by individual power plants.

Frequency restoration reserves (FRR) are operating reserves necessary to restore frequency to the nominal value after sudden system disturbance occurrence and consequently replace FCR, if the frequency deviation lasts longer than 30 seconds. This category includes operating reserves with an activation time typically between 30 seconds up to 15 minutes. Operating reserves of this category are typically activated centrally and automatically.

Replacement reserves (RR) are operating reserves necessary to restore the required level of operating reserves in the categories of frequency containment (FCR) and frequency restoration (FRR) reserves due to their earlier usage. This category includes operating reserves with activation time from several minutes up to hours.

However, the Nordic grid code defines the above reserves as *frequency-controlled normal operation reserve (FCNOR)*, *frequency-controlled disturbance reserve (FCDR)*, *fast active disturbance reserve (FADR)* and *slow disturbance reserves (SDR)*. The FCNOR and FCDR are the automatic active reserves and it corresponds to the FCR defined by the ENTSO-E. The FADR and SDR are the fast and slow reserves that are activated manually. The following will describe the reserve required in Danish power systems.

3.2.1 Primary control reserves

These automatic reserves stabilise the frequency at around 50 Hz, when frequency deviates from its nominal level. The generating units equipped with speed governors must be capable of supplying the primary reserves, required by Nordel and the CE, with a fast reacting power controller. These reserves are supplied to continuously and reliably control the active power supply. The generating units operating at 50-90% of their nominal power shall provide at least $\pm 5\%$ of the nominal maximum power within 30 seconds. The active power controller must have a droop within the range of 2% – 8% with an adjustable dead band that can be set within the ± 0 mHz to ± 200 mHz range [19].

The primary reserves consist of the FCR in Western Denmark and FCNOR and FCDR in Eastern Denmark. The requirement on these reserves in CE, Nordic and Danish power systems is as following:

Frequency Containment Reserve (FCR) [58]

In CE, ± 3000 MW of FCR is required for primary control purposes. These reserves must be fully activated in 30 seconds, if frequency deviates by ± 0.2 Hz. The activation of FCR is subjected to the power frequency characteristics (β_{PS}) of the primary control for the electrical network. In CE, the minimum β_{PS} of 15000 MW/Hz is required at all times. The speed governors in the CE power system should respond for any frequency deviation greater than ± 0.01 Hz.

For the disturbance less than 1500 MW, the required FCR must be fully activated in 15 seconds. It has been assumed that deployment time of less than 15 seconds will be difficult to achieve for power imbalance smaller than 1500 MW. For a disturbance between 1500 to 3000 MW, the FCR response should be within linear time limit of 15 to 30 seconds. The Figure 13 illustrates the minimum deployment of FCR as a function of time and the size of the power imbalance.

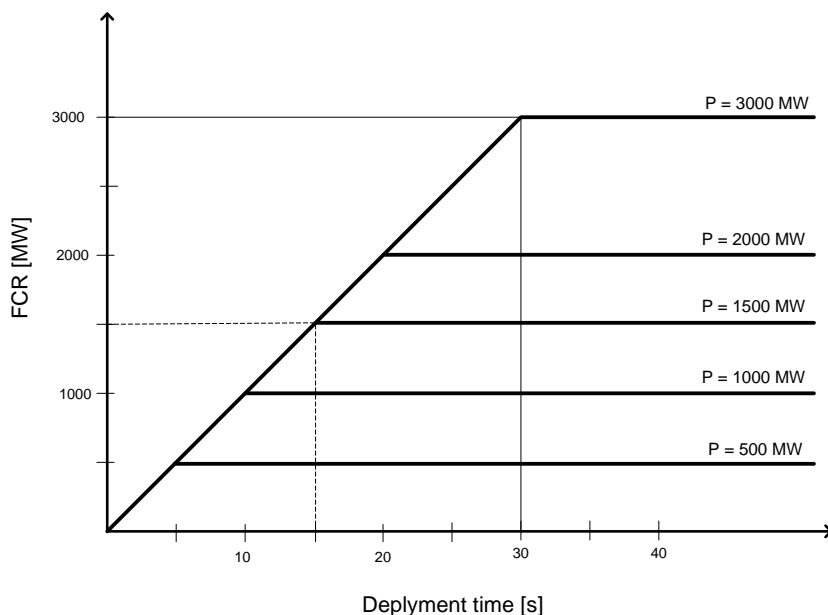

Figure 13: Deployment time for FCR in CE by the ENTSO-E

The FCR is distributed between the subsystems of the CE power system in accordance with the annual consumption during the previous year. As for example in 2011, the western Denmark shared ± 27 MW of the FCR in the total required reserves [59, 57].

Frequency – Controlled Normal Operation Reserve (FCNOR) [57, 59, 60, 61]

FCNOR is used to avoid frequency deviations in the Nordel synchronous system. The FCNOR shall be activated linearly until the full reserve is utilised for a frequency deviation of 0.1 Hz with 50 Hz being the reference value. The FCNOR shall be at least ± 600 MW at 50.0 Hz for the Nordic synchronous system and shall be regulated upward or downward within 2-3 minutes for ± 0.1 Hz of change in frequency.

The FCNOR is distributed between the subsystems of the Nordic synchronous system based on previous year's power consumption. Eastern Denmark share ± 23 MW of FCNOR in the year 2011. Also, each subsystem of the Nordic synchronous system shall have at least 2/3 of the FCNOR in its own system in the event of splitting up and island operation.

Frequency – Controlled Disturbance Reserve (FCDR) [57, 59, 60, 61]

Nordic grid code defines the FCDR as “a reserve of such magnitude and composition that dimensioning faults won't entail a frequency of less than 49.5 Hz in the synchronous system”. The FCDR shall amount to an output power equal to the dimensioning fault minus 200 MW as self-regulation of the load and it must be available for usage until the FADR has been activated. The dimensioning fault is defined as the single contingency that can happen with a probability of once every third year that leads to the largest loss of generating capacity. In Nordic region, it is approximately 1400 MW and it corresponds to a nuclear power plant in Sweden or the largest

hydro power plant in Norway. The self-regulation of the load was estimated to 200 MW. The total FCDR requirement is thus approximately 1200 MW, which is allocated between subsystems of the Nordic synchronous system according to the relative dimensioning faults of the individual areas on a weekly basis. Eastern Denmark share approximately 160 MW in the year 2011.

The FCDR shall be activated at 49.9 Hz (when FCNOR has been fully activated) and be completely activated at 49.5 Hz. It must increase as good as linearly throughout the frequency range of 49.9-49.5 Hz. In the case of a momentary frequency drop to 49.5 Hz caused by momentary loss of production, 100% of the FCDR shall be regulated upwards within 30 seconds. Agreed automatic load shedding in the event of frequency drops to 49.5 Hz can be counted as part of the FCDR.

Figure 14 illustrated the correlation between FCNOR and FCDR. The Nordic grid code also require the activation of FCNOR with minimum response of 6000 MW/Hz and FCDR with 2500 MW/Hz.

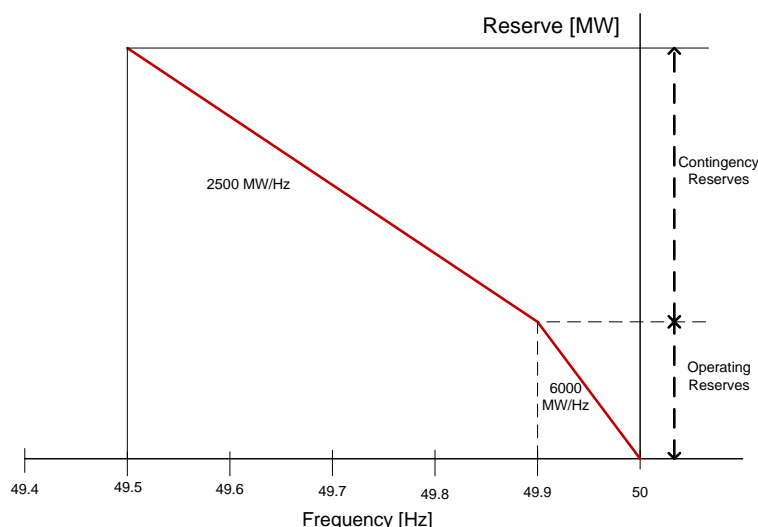

Figure 14: Primary reserves and power frequency characteristics of Nordic power system

3.2.2 Secondary controlled reserves

Secondary control is responsible to restore the primary reserves, restore scheduled power flow on tie lines and return system frequency to nominal level within 15 minutes. The automatic reserves, in CE (FCR) and in Nordic (FCNOR & FCDR), are allocated among each control area to stabilize the power system following a power mismatch between generation and load demand. The deployment of these reserves stabilizes the system frequency at new level and deviate the power exchange from their scheduled values. The automatic secondary reserves (FRR) then have to be activated in the control area responsible for the power imbalance to bring back the frequency to its nominal level, restore the primary reserves and also restore the power exchange

to its schedule. The secondary reserves can be shared among the partners, provided there is no potential congestion in the transmission system that might prevent the activation of the reserves. FRR must be available within 15 minutes to restore the system to normal state following faults. The size of these reserves is determined by the individual subsystem's assessment of local requirements [56].

In Western Denmark, Energinet.dk is currently using central AGC for the deployment of FRR. The AGC handles the unforeseen imbalances in western Denmark, so that the power exchange on AC link between with Germany is kept at its schedule. The AGC is required to respond not later than 30 seconds and fully activate FRR within 15 minutes at most. The AGC reserve requirement is based on the maximum consumption. The AGC capacity is currently limited to ± 90 MW as the majority of imbalances are handled in the control room through manual reserves, using operational planning to a large extent [57, 59].

3.2.3 Manual reserves

Each TSO is responsible to ensure that the load demand should be covered at all times by electricity produced in that area, together with electricity imports from neighbouring control areas. In order to maintain this balance, generation capacity must be available to cover power plant outages and any disturbances affecting production, consumption and transmission. In European context the manual reserves are also called tertiary control reserves, activated in the form of regulating power to release the automatic reserves and deal with the prolonged power imbalances due to forecasting error or contingent events. The manual reserves ensure the minimum amount of regulating power to deal with the outage of a dimensioning unit (N-1 contingency) in the Eastern or Western Danish power system. The dimensioning unit will be a national transmission line, international interconnector or a generation unit.

In Eastern Denmark, 300 MW of fast and 300 MW of slow manual reserves are required as FADR and SDR, respectively. The FADR is available within 15 minutes and SDR after 15 minutes to deal with power imbalances in Eastern Denmark. The reserve power in Eastern Denmark is also used to counter the contingency events in the Western Denmark via GBL. In case of contingency, the exports to Eastern Denmark can be reduced to handle the dimensioning fault in Western Denmark. While in case of power import, Energinet.dk can reserve up to 300 MW on the GBL in the westbound direction for operational security of Western Denmark during contingent events. However, in the event of heavy westbound power flow, Energinet.dk will specifically consider purchasing of extra reserves in Western Denmark. Energinet.dk only keeps 250 MW as manual reserves (RR) in Western Denmark for dealing with the power imbalances and release of automatic reserves [57, 59].

3.3 Active power regulation from WPPs

During the first two decades of wind turbines (1980 – 2000), they were exempted from providing any grid support services. The wind turbines were then being connected to a fairly strong grid where conventional power plants dominated the overall generation. However, the increasing integration of wind power imposed new challenges for the power system operation, raising concerns about its dynamic security and reliability. To deal with possible challenges, some of the TSOs of highly wind power integrated power system have revised grid codes to secure its operation and facilitate additional integration of wind power into power systems in a secure and reliable manner. In this regard, the WPPs connected to Danish power system have to cover several regulating functions to control its output power. The regulating and constraint functions imposed by the Energinet.dk are subjected to the conditions of the grid and wind. This is to ensure that the various regulating and constraint functions do not interfere with each other. The regulating functions are listed in a priority order in the following [16]:

3.3.1 System protection

During overloading in the grid, system protection function regulates the active power from WPP to an acceptable level. This regulating function contributes to avoid system collapse in case of any unforeseen incidents. The down regulation in wind power starts when system protection signal is activated and continues till the termination of external signal. It must be possible to set up at least five different set points for the WPP and if require to change the set point, it must be done not later than 10 seconds after receiving instructions. The power output in system protection must not differ by more than $\pm 2\%$ of the set point value. The system protection regulation is shown in the Figure 15 and is applied on the power plants having capacity more than 1.5 MW.

3.3.2 Frequency control

The automatic frequency regulation shall change the output power of the WPP to restore the frequency with an accuracy of ± 10 mHz in case of deviation. The frequency control function from the WPP is shown in Figure 16. The frequencies between $f_2 - f_3$ form a dead band, whereas the WPP shall provide the primary control with Droop 1 if frequency is in between $f_1 - f_2$ and with Droop 2 if in between $f_3 - f_4$. The critical frequency control is supplied with Droop 3 and Droop 4 for frequency in between $f_4 - f_6$.

P_{DELTA} set aside reserves and is used to stabilize the system frequency, if frequency drops from point f_2 . If frequency rises from f_3 , the active power from the WPP is regulated downward. The WPP shouldn't up regulate its active power output if frequency reaches to point f_5 , until the grid

frequency reduces than f_7 . The shutting down of individual wind turbine is also allowed in case it is needed to down regulate the active power below P_{min} .

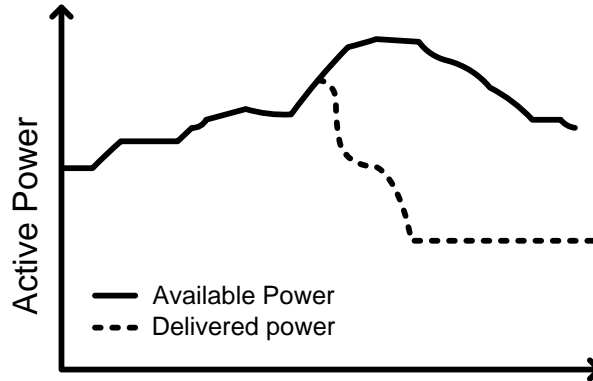

Figure 15: System Protection

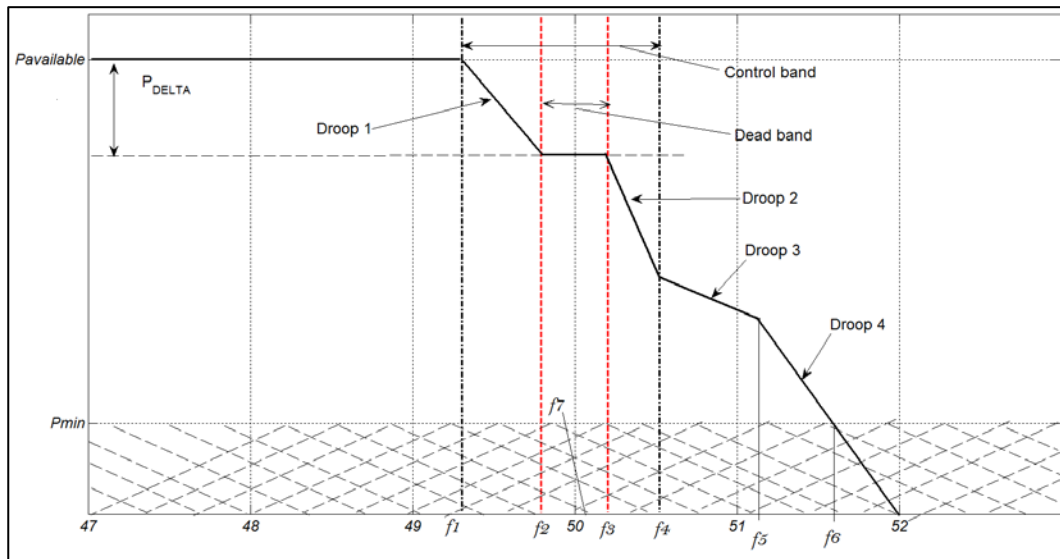

Figure 16: Frequency Control Regulation

The frequency control regulation is applied on the WPP having capacity larger than 25 MW. The frequency set points can be changed not later than 10 seconds after receiving order signal. The accuracy of the power output must not deviate by more than $\pm 2\%$ of the set point value.

3.3.3 Constraint functions

The constraint functions are the auxiliary active power control functions that are used to avoid imbalances or overloading of electricity network during faults or other unpredictable events. The WPP must be equipped with the following constraint functions, i.e. power gradient constraint, absolute gradient constraint and delta production constraint. These constraint functions are described below:

I. Power gradient constraint

This constraint function limits the rate in wind turbine output power with respect to wind speed changes, as the conventional power plants might not be able to change their output as fast as the wind speed is changing. The settings for the power gradient constraint are provided by the system operator. Power gradient constraint function is shown in Figure 17 and is applied on the WPP having capacity larger than 1.5 MW.

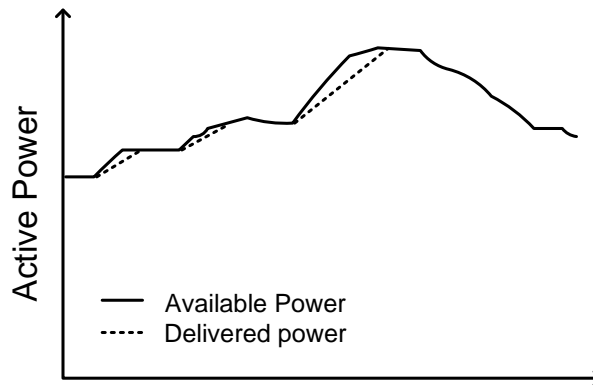

Figure 17: Power Gradient Constraint

II. Absolute production constraint

This regulating constraint limits the current power production of a WPP to random set MW value, when available power is in range of 20% to 100% of rated power. The maximum allowable deviation is $\pm 0.5\%$ of rated power at connection point. This regulating function shall not overload the grid and is demanded from WPP having capacity larger than 1.5 MW. Absolute production constraint function is shown in Figure 18.

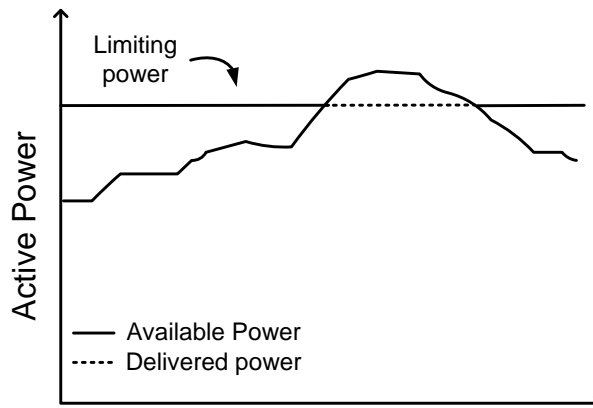

Figure 18: Absolute Power Constraint

III. Delta production constraint

This constraint function limits the current power production of a WPP by a fixed amount in proportion to the available power, thereby setting aside reserve for handling critical power

requirement. Delta production constraint function can take part in frequency control. It reduces the power fluctuations due to high wind thus reducing the need of spinning reserves. Delta production constraint function is exemplified in Figure 19 and is applied on WPP with capacity larger than 25 MW.

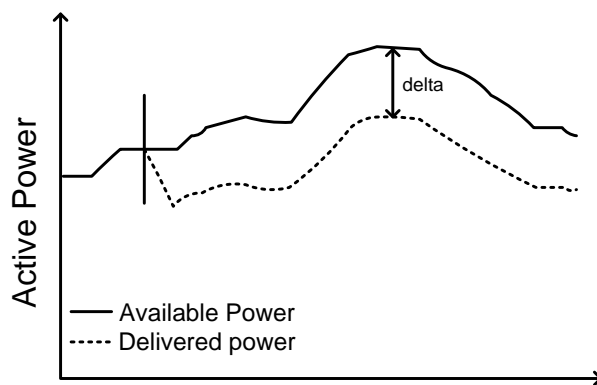

Figure 19: Delta Power Constraint

If a change in the set points for the above constraint functions is obliged, it shall commence within two seconds and completed not later than 30 seconds after receiving an order signal from the system operator. The power output must not deviate by more than $\pm 2\%$ of the set point value or by $\pm 0.5\%$ of the rated power, depending on which provides the highest tolerance.

Different control techniques discussed above make WPPs able to participate in frequency control services during certain conditions. However, the large scale integration of wind power in future may also requires services like primary and secondary balancing control from the WPP on continuous basis. The fast ramp rate need for the balancing response is not a technical threshold for WPP to participate in frequency control services. Reserves can be set aside from hour-ahead forecast wind power forecast or operating in a delta mode, to enable the WPPs to participate in primary and as well as in secondary control purposes. But, the variability of wind power with a limited predictability hurdles the full time availability of reserves. However, less tight standards for WPPs may be defined in the future to have a certain capacity at a certain availability rate.

Even if WPP participates in the frequency control services, yet the economic feasibility of setting aside reserves is still to discuss. Wind power being cheapest source of producing electricity receives a dispatch priority and the most profitable strategy for a WPP is to produce at maximal capacity. Keeping wind power as an upward regulating reserving is expensive as the WPP has to produce continuously under maximal capacity. The upward regulating reserve imposes a reservation cost, depending on the lost revenues of electricity and is determined by the electricity price that could have been sold otherwise. On the other hand, keeping downward reserves has no

reservation cost, as WPP normally produces the available wind power but participates in the active power balance control during positive imbalances.

3.4 Summary

This chapter provides an overview of the main aspects regarding the power balancing control in the Nordic and CE synchronous power systems. The power frequency characteristics of the electrical network decide the stiffness of the synchronous power system that depends on the frequency characteristic of the generating units operating in the power system. The AGC, based on area control error provides the desired secondary response to return the system frequency and the power exchange to its schedule following a power imbalance. The area control error depends on the frequency control error and power control error, which is the deviation seen on the AC interconnection from its schedule following the power mismatch. The area control error replicates the total power imbalance, if AGC bias settings, for the calculation of frequency control error, equal to the power frequency characteristics of the control area where power imbalance occurred. The frequency control error then emulates the primary response of that control area.

The main part of this chapter reports the balancing reserves in the Nordic and CE power system. The CE follows the ENSTO-E definition for the reserves requirement, while Nordic grid codes define the reserves as automatic and manual reserves. These reserves are distributed between the subsystems of the synchronous power system based on previous year's power consumption and relative dimensioning faults. In CE, the secondary reserves are activated automatically through central AGC system.

This chapter also presents the requirements for active power regulation from WPP connected to the Danish grid for secure and stable operation of the power system with increasing large scale integration of wind power. The WPPs require certain control functions that include system protection, frequency control and constraint functions like absolute production, delta control and power gradient. However in future, the WPP may be required to participate in active power balance control services, same as other conventional power plants, to uphold the secure and reliable operation of large scale wind power integrated power system.

Wind Power Plant System Services

Chapter 4

Power system modelling and control

Increasing wind power integration influences the power system operation, particularly the active power balance control. The variable wind power generation together with the technical capabilities of the generating units and the market rules might hinder the power system balance control. These factors must be taken into account while planning the power balancing operation of a large scale wind power integrated power system.

This chapter models the real-time balance control for future Danish power system with large scale integration of wind power. The chapter initially describes the generation of HA balanced regulating power plan, in a five minute resolution, for generation and power exchange with neighbouring power systems. It then follows with the implementation of AGC system and a coordinated control strategy between CHPs and WPPs, where WPPs can contribute actively in active power balance control while deciding the secondary dispatch with minimum cost. The chapter also proposes an algorithm ‘rolling balance’ to further reduce the real-time power imbalance and secure power system operation.

4.1 Hour-ahead Regulating power plan

Traditionally, TSOs accept the hourly regulating bids for balanced power system operation. These bids are selected to preserve system security and to minimize generation cost, without any information of power balancing within intra-hour. For large scale wind power integration, as the case of future Danish power system, the intra-hour balancing will be required due to the intermittent and uncertain nature of wind power. In order to maintain a close balance between generation and demand, the Danish TSO for electricity and gas, Energinet.dk, together with the Technical University of Denmark has developed a new model capable of modelling the intra-hour power balance control. This model, known as SimBa, is based on the Danish principles of balancing. The model scales the balance operation down to a five minute time period and therefore have more precise forecast of the system’s behaviour. It closes the gap between traditional energy models and intra-hour power balancing models by simulating the procedures taking place in the operator’s control room.

4.1.1 Balancing concept of Danish power system

The power balancing model, SimBa, is developed on the operational principle of Danish power system, where electricity market is responsible for the balanced power system operation [62]. In order to understand the principles on which the SimBa generates the HA time series for generating units and power exchange with neighbouring power systems, it is required to understand the Danish operational principles and the market design.

The power balance responsible players' trade in the electricity market for the balanced operation of the power system. Examples of electricity markets are the day-ahead, intraday and regulating power markets. The balance responsible players trade in spot market to balance the power system for each operating period in the next day. These players send their bids for production and consumption to the Nordic power exchange, Nord Pool Spot. The spot market closes at 12:00, one day before the operating period. The Nord Pool Spot select the hourly bids for purchase and sale one day prior to physical delivery and therefore referred as a day-ahead market. Within this process, the bids are selected with foremost intent of preserving system integrity and then to minimize the overall operating cost. The bids selection is subjected to different constraints, such as transmission constraints, capacity constraints and generating technologies.

After market clearance, the unsuccessful players then might offer their potential production/consumption as regulating power. These regulating power bids are added to the Nordic Operational Information System (NOIS) list with their price and amount for upward or downward regulation. The market players are obliged to send updated operational schedules to Energinet.dk whenever they experience a change in their production/consumption. In this way, the Energinet.dk has always the best possible knowledge of the regulating power available in real-time operation.

Energinet.dk updates the schedule based on the updates of wind or load forecast by activating the bids from the NOIS list on the intraday. There are several rules for activating bids, a bid should, for example, be activated for at least 30 minutes and the size of the activated bid should be at least 10 MW [62]. Some rules help to stabilise the system and some rules are made to help to protect the production equipment. The bids activated by the Energinet.dk need not necessarily be from Danish power system, it could be anywhere inside the Nord Pool Spot area. The bids with lower cost are activated, taking in account the transmission constraints of the power system.

Energinet.dk has to maintain the power system in close balance during the operational hour. The TSO has to react to larger power imbalance by activating the regulating power. The smaller power imbalances are minimized by the automatic frequency reserves in the power system. However, the use of expensive automatic reserves is minimized by activating the slower reserves

to minimize the balancing cost of the power system. The following Figure 20 summarizes the market design and principle of power balance control.

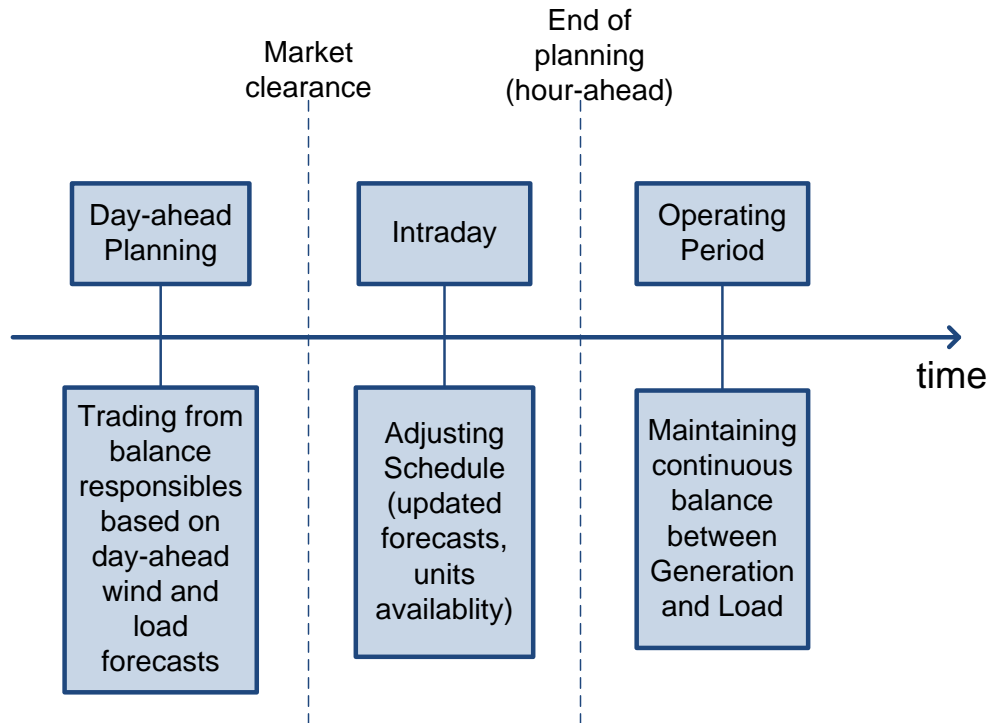

Figure 20: Operational design of electricity market

4.1.2 Simulation Power Balancing (SimBa) model

The intra-hour operational management is crucial for the power system optimization, especially for large scale wind power integrated power system. The TSO should not only manage the real-time power balance control, but also estimate the changes that have to be done to the existing electricity grid in order to ensure good function and lowest cost. SimBa models the system in a detailed way taking into accounts the current grid regulations and energy market rules. It calculates the type and amount of reserves which should be activated in the hour-ahead operation time frame, while taking market rules in account.

SimBa uses inputs from UC models including hourly values for energy production, load and the power exchange between interconnected areas. The UC model simulates the spot market and returns time series for production, consumption, prices etc. in an hourly time resolution. WILMAR, an abbreviation of ‘Wind Power Integration in Liberalised Electricity Markets’, is an example of such program used to model the spot market as a perfect market with a UC and dispatch model. In this study, the outputs from WILMAR are used as inputs to SimBa. The power balancing model transforms the hourly resolution time series into a more detailed resolution, i.e. five minutes and simulates the real-life operational schedule.

The generation of power schedules in SimBa differs for different types of production, consumption and exchanges. In this study, SimBa assumed that the consumption is perfectly forecasted which also can be interpreted as if the consumption is known one hour in advance. The schedule for power exchanges takes the ramping requirements in account, as Denmark's neighbouring power systems ramp the agreed power exchange in different durations and at different starting times. For example, in the Nordic power system, the agreed power exchange shall be ramped within 30 minutes and shall begin 15 minutes before the agreed exchange hour. Meanwhile, in the CE power system, the power exchange shall be ramped within 10 minutes and shall start 5 minutes before the agreed exchange hour [14]. The difference in power exchange ramping might lead to a power imbalance in Danish power system at an agreed hour. For example, if the power has to be transported from the Nordic power system to the CE power system or vice versa, it might end in a power surplus or deficit in the Danish power system, respectively. SimBa analyses this problem and activates an extra regulating bid to overcome the imbalance due to the difference in power ramping.

SimBa also takes in account the ramping characteristics of the conventional generating units and ramps their power schedule with a rate of 30 MW/min. The detailed power schedule for the wind power is generated based on the hour-ahead forecast of wind power. SimBa estimates the fluctuations from hour-ahead forecast and generates the possible wind power schedule in a five minute resolution within the operating hour. This intra-hour variability is not modelled by most wind power forecast systems. In this study, the day-ahead and hour-ahead forecasts of wind power are provided by the Correlated Wind power fluctuations (CorWind) model. According to [8], CorWind simulate the wind power time series over a power system region. It reanalysis data from a climate model adds a stochastic contribution to provide the mean wind flow over a large region which varies in time and space. The detailed power schedules for power exchanges, load consumption and generating units (conventional and wind) in five minute resolution can be interpreted as the available schedules prior to the operating hour, which are used for the calculation of hour-ahead power imbalance.

SimBa also creates list similar to the NOIS using as input the technical characteristics of the units and the marginal costs. SimBa calculates the available capacity in the power system from the maximum and actual production of the online generating units. Knowing the marginal cost function of each unit, a merit list for upward and downward regulation is created.

SimBa, from detailed power schedule, calculates the mean imbalance for half an hour and balances the power system internally in different areas, considering the grid regulation, transmission losses and transmission constraints. It activates the regulating power from the above mentioned list, while taking the market rules in account. This simulates almost similar real-life

operations at Energinet.dk, although Energinet.dk continuously updates schedules and activates regulating power.

To understand the operation of SimBa, an example is illustrated below with inputs from the UC model and the wind power forecast model, as shown in Figure 21. This example helps in understanding the generation of hour-ahead schedule for balanced power system operation.

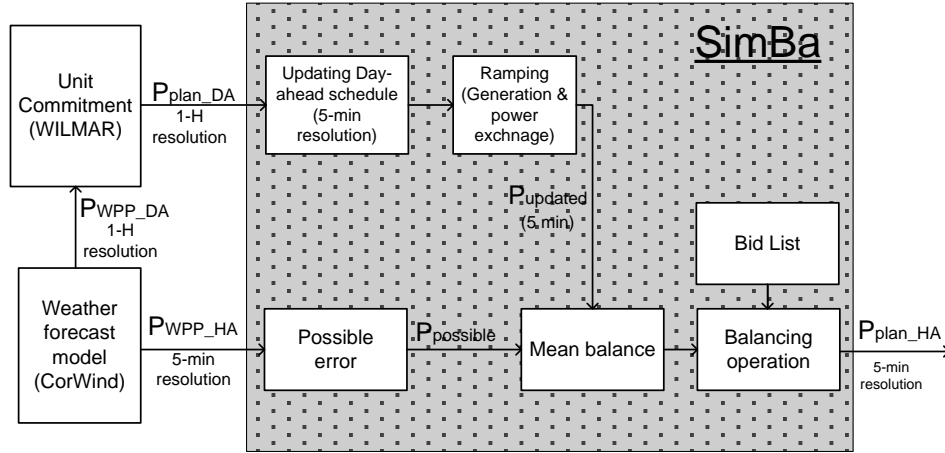

Figure 21: Generation of hour-ahead schedule from SimBa

i. Hourly inputs from unit commitment model

The UC model after simulating the spot market generates the balanced schedule for the power system. WILMAR is an example of UC and dispatch model that provides day-ahead plan (P_{plan_DA}) for balanced power system. This study uses the P_{plan_DA} , as an input to the SimBa, for the generation of hour-ahead schedule (P_{plan_HA}) for the Danish power system. The P_{plan_DA} , shown in Figure 22, has an hourly time resolution and completely balanced. The power exchange in the figure shows the power exports from the neighbouring power systems.

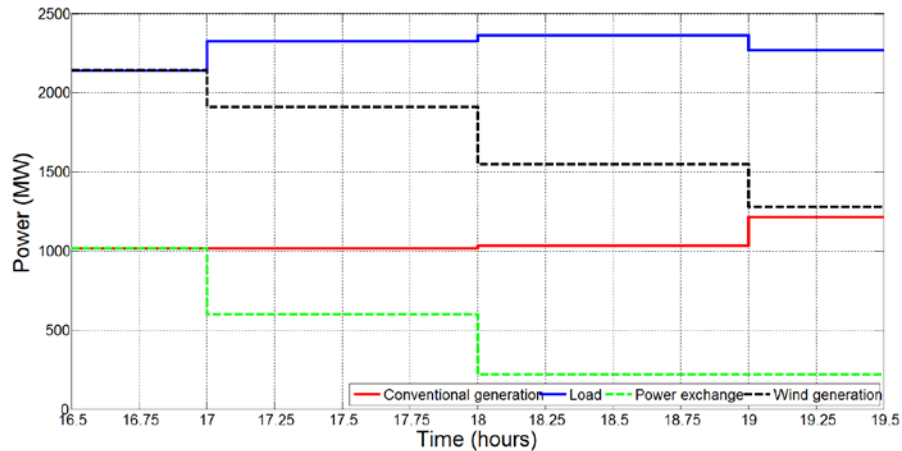

Figure 22: Day-ahead schedule from UC model in an hourly resolution

Apart from energy production, energy demand, power exchange and wind power forecast, WILMAR also provide the information regarding technical characteristics and marginal costs of generating units and the bid prices.

ii. Updating Day-ahead schedule

The SimBa model, after receiving the inputs from UC model, will update the hourly day-ahead schedule to five minutes resolution. Simba model than simulates both ramping on interconnection lines and ramping in the schedules for the power plants. The ramping starts 15 minutes before the operating hour and ends 15 minutes after. As SimBa model assumes that the consumption is completely forecasted, so it will smooth out the hourly series of load consumption and will update the schedule. The updated schedule for the power exchange, load consumption and conventional generation is shown in Figure 23.

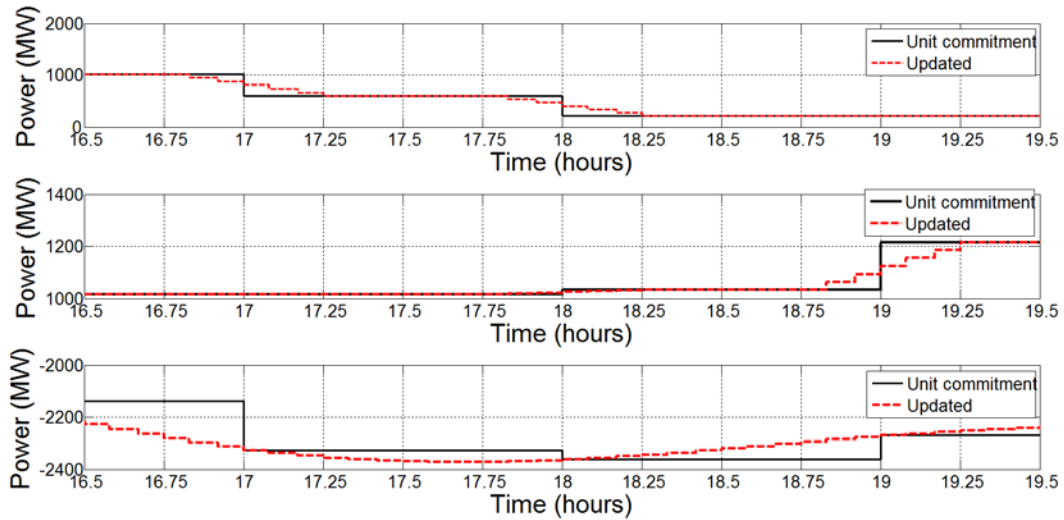

Figure 23: Updated day-ahead schedule: top: power exchange, centre: conventional generation and bottom: load

The ramping on the power exchange and on the conventional generating units will add an imbalance and so the system will be longer in balance with updated day-ahead schedule.

iii. Possible wind power schedule

The CorWind model provides the hour-ahead forecast of wind power based on the data provided by the weather model for every six hours. From this forecast, Simba generates the possible wind power schedule within the operating hour. The generated wind power schedule is more precise as it is forecasted closer to the operation time. Figure 24 shows the hour-ahead forecast of wind power from the CorWind.

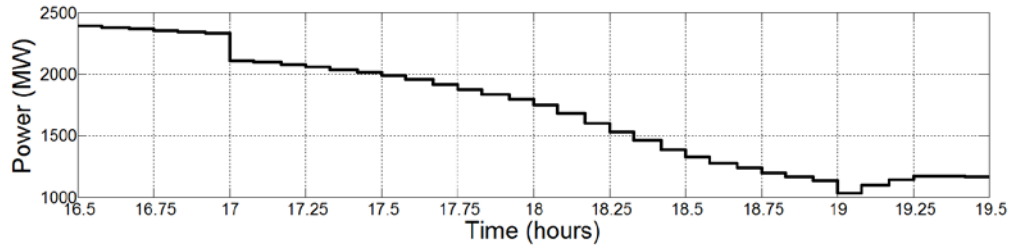

Figure 24: Hour-ahead wind power forecast in five minute resolution

iv. Balancing operation

The system with updated schedule and wind power forecast is no longer in balance. The ramping and the predictability of the wind forecast cause an imbalance in the system. The power imbalance before and after updating the day-ahead plan and wind power forecast is shown in Figure 25.

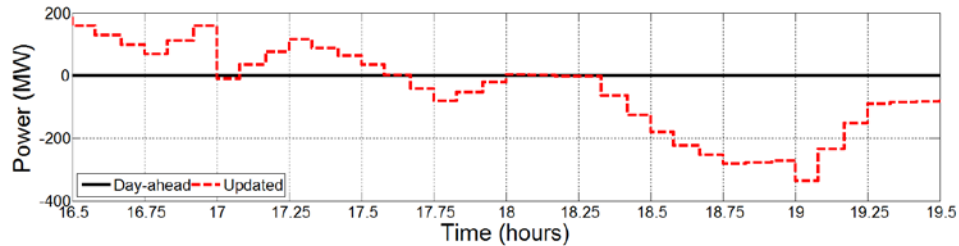

Figure 25: Power imbalance before and after updating the day-ahead plan

SimBa will handle this imbalance before the operating hour by activating regulating power, as it is done by the Danish TSO. SimBa activates the bids from the bid list for balanced power system operation. The bids are activated while taking care of the market rules, i.e. the minimum activation time (30 minutes) and minimum bid level (10 MW). After bid activation process, SimBa generates the hour-ahead schedule and provides the balanced plan for generating units and power exchange with neighbouring power systems with five minute resolution.

Due to the uncertain nature of wind, the wind power within the operating hour may not be the same as its estimated value and this aspect can create power imbalance within the operating hour. The hour-ahead forecast of wind power and the available wind power is shown in Figure 26, while Figure 27 shows the real-time power imbalance and the wrong forecast of wind power.

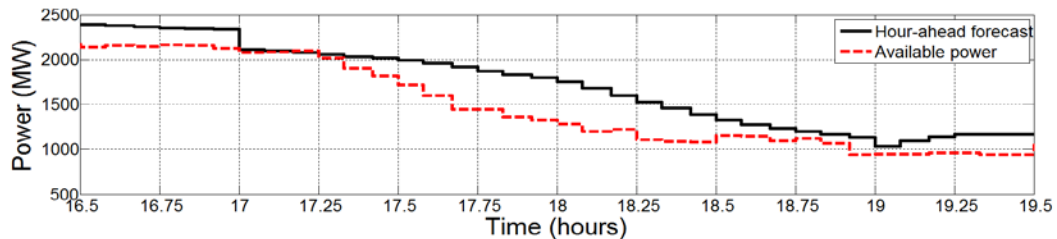

Figure 26: Hour-head forecast and available wind power

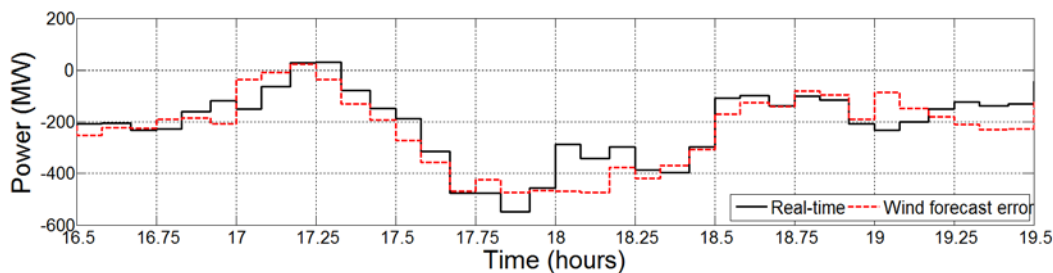

Figure 27: Real-time power imbalance and wind power forecast error

From Figure 27, the real-time power imbalance does not follow completely the hour-head wind power forecast error as SimBa while activating power bid takes ramping on interconnections and generating units in account.

The real-time power imbalance is then partially compensated by the activation of FCR, FRR and RR. In this study, the activation of FCR depends on the power frequency characteristics of the synchronous power system and will be discussed in next chapter, while FRR are activated through AGC. The AGC has a reserved capacity of ± 90 MW (conventional reserves), as the one acting on the border of Western Denmark with Germany. In the present investigation, it is more often assumed that the power imbalance within the operating hour is controlled only through AGC, along with automatic response from the synchronous area. Although the activation of RR is also studied to further minimize the real-time power imbalances. The manual reserves are activated with an algorithm names as ‘rolling balance’.

4.2 Modelling of Automatic Generation Control (AGC)

An imbalance between electric power generation and load demand will result in a frequency change within the complete synchronous power system. The system frequency drops from 50 Hz, if the load demand is higher than the total generation and increases vice versa. The fundamental principle of power system operation is to keep frequency within the nominal range at every instant; as any deviation beyond acceptable limit may threat the reliable and secure operation of the power system. As aforementioned, the frequency deviation from its nominal level is either due to some contingent events or due to the wrong forecast of wind power or load demand. The frequency deviation due to the wrong forecast of wind power is more consistent with increasing wind power integration, generating power imbalances owing to its intermittent behaviour. In practice, power balancing operation is required on real-time basis to deal with these unforeseen power imbalances.

The generators within the synchronous power system equipped with speed governors provide the initial support by releasing the primary control reserves for any change in system frequency from its nominal level. This response depends on the power frequency characteristics of the synchronous power system, as explained in Chapter 3. The synchronous power system will

activate the primary control power of ‘ ΔP ’ throughout the power system, if the system frequency deviates by ‘ Δf ’ from its nominal level:

$$\Delta P = -\beta \cdot \Delta f \quad (20)$$

where, ‘ β ’, network power frequency characteristics, equals to the sum of primary frequency responses from all participating generating units within the power system. The primary response re-establishes the power balance at a new steady state frequency, other than the set point value. However, this will diverge the power interchange between the control areas from its schedule, as all control areas within the synchronous power system contributes for the primary control process. The secondary control is then required to activate the power reserve from the control area where power imbalance occurred in order to restore the system frequency to its nominal level and the power interchange to its schedule.

The imbalance is generally met by implementing the AGC. It is intended to balance the power system by managing the response of available resources within minutes as opposed to primary frequency response, which manages response within seconds. The AGC, developed and implemented in this investigation to study the power balance control within the Danish power system, is sketched in Figure 28.

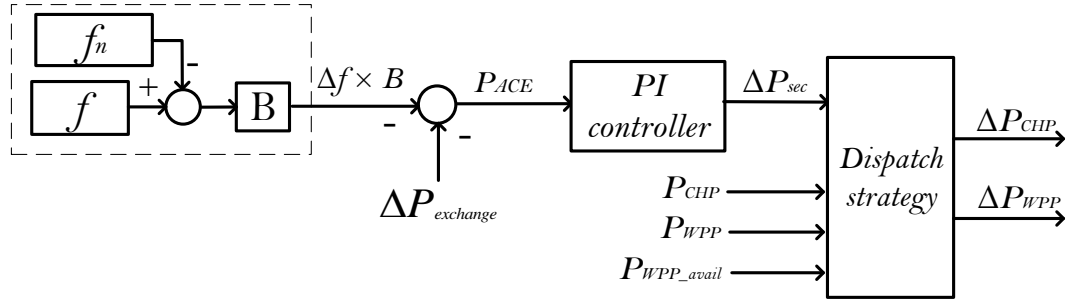

Figure 28: Developed AGC model

The AGC takes care of any imbalance using P_{ACE} , the area control error, as input signal. P_{ACE} is measure of frequency deviance from its nominal level and also the power exchange deviation from its schedule. The deviation on the tie-line from its scheduled power exchange is also the residual power imbalance in the control area after primary response. The P_{ACE} is calculated as sum of the power control error ($\Delta P_{exchange}$) and the frequency control error ($\Delta f \cdot B$), already discussed in (10). The power control error ‘ $\Delta P_{exchange}$ ’ is the power deviation from the scheduled power exchange of the control area. In other words, $\Delta P_{exchange}$ is the primary response from the interconnected power system and can be seen as power deviation on the external grid in this study. The power control error can also be calculated as the difference between total generation, load demand and total scheduled power interchanges with neighbouring control areas:

$$\Delta P_{exchnage} = \sum P_{Gen} - \sum P_{Load} - \sum P_{Interchange} \quad (21)$$

where, P_{Gen} is the real-time power generation within the Danish power system after the primary response due to power mismatch.

The other half of the area control error is the product of frequency deviance and frequency bias settings of the AGC system ' $\Delta f \cdot B$ ', i.e. frequency control error. Depending on the frequency bias settings, the frequency control error prevents the premature withdrawal of generator primary frequency response as long as frequency returns to its nominal level. In this study, the frequency bias B is equivalent to the primary frequency characteristics of the Danish power system, i.e. the sum of the power frequency characteristics of the operating generating units (CHPs, DCHPs and WPPs). Therefore, the frequency control error will almost replicate the primary response offered by the generating units within each part of the Danish power system. It is to be noted that the power frequency characteristic of the generating unit is a dynamic factor which depends on the droop characteristics, operating point and available generation capacity. However, the frequency bias B is a constant value and is calculated as:

$$B = \beta_{CHP} + \beta_{DCHP} + \beta_{WPP} \quad (22)$$

The power frequency characteristics of the generating units is discussed and calculated in the next chapter. These power frequency characteristics of the control area will reduce if the generating units are operating on their limits. In that case the frequency control error will not replicate the primary control and will result in a higher value. However, this will not affect the performance of the AGC, as according to [63], the AGC with higher frequency bias setting than the power frequency characteristics of the control area will correct the frequency deviation faster. On the other hand, a lower value for the frequency bias degrades the frequency control performance of the power system.

The function of the AGC, to maintain a balance within the control area, is achieved by keeping the power control error and frequency control error close to zero. The AGC processes the P_{ACE} and dispatches the generating units to do so. In this regards, the tuning of the AGC controller impacts the performance of the power plants participating in the secondary control. The power plants characteristics vary widely and a number of constraints exist with regard to their response, for-example the response time associated with the CHP is in order of minute while WPP responds in seconds. Therefore, a simple and well damped system for secondary control purpose is preferred that results in a smooth control in bringing down the area control error to zero. In this study, the desired behaviour of the AGC over time will be obtained with a PI regulator:

$$\Delta P_{sec} = K \cdot P_{ACE} + \frac{K}{T} \int P_{ACE} \cdot dt \quad (23)$$

where, ΔP_{sec} is the delta set point for generating units providing the secondary response, K is the proportional gain, T is integration time constant of the secondary controller in control area and P_{ACE} is the area control error in the imbalanced control area.

During real-time operation, the power plants characteristics in relation to the power imbalances are such that it is difficult to perfectly match the generation and load continuously. Although, appropriate parameters for K and T are needed for the secondary controller to return the system frequency and the power interchange to their set point values. In this study, the parameters setting for AGC follows the CE guidelines, where a factor 0.2 is used for tuning the proportional term (K) and 55 second is used for the integral time constant (T). These parameters will results in a well damped performance of the AGC system while returning the frequency back to nominal level. The performance of the AGC system is shown in next chapter, when a load step is applied to validate the performance of the developed generating units.

The required secondary control action ' ΔP_{sec} ' is then distributed among the actively participating generating units through secondary dispatch. In this study, the 'dispatch strategy' decides the delta set-points for active participating generators, namely CHP and WPP, as shown in Figure 28. The dispatch decides the change in reference power for the generating units CHP and WPP, i.e. ΔP_{CHP} and ΔP_{WPP} , by using as input signals ΔP_{sec} , CHP generation (P_{CHP}), WPP generation (P_{WPP}) and the available wind power (P_{WPP_avail}). Moreover, the dispatch strategy also takes in account the power generation limits (minimum and maximum) from the participating generating units.

4.3 Dispatch strategy – Integrating WPP in AGC control

AGC dispatch manoeuvres the power set points of the generating units, participating in the secondary control, to maintain the real-time balance between generations and load while keeping the cost at its minimum. Traditionally, conventional power plants carry this task and are capable of meeting the TSO guidelines. Their possible replacement in future by WPPs of similar size increases the risk of system failures, unless the TSOs revise and set new requirements for the active power balance control.

The increasing integration of wind power demands services from WPPs similar to the conventional power plants, as some of these power plants might be replaced by WPPs. The WPPs can support the real time balance control, as discussed in section 3.3, and it is the need of hour to integrate the WPP control into the AGC dispatch for the secure operation of highly wind power integrated power system. The primary problem associated with the incorporation of wind power into the AGC dispatch is the fact that the available wind power is exactly not known. The TSOs may also be facing problems of allocating the dispatch power among conventional generators with more widespread use of WPPs. Therefore, a coordinated control strategy for the AGC between conventional and wind power plants is required to enhance the security and reliability of a power system. This study proposes a control strategy for the AGC dispatch between CHPs and WPPs in order to improve the active power balance in power system, while keeping the secondary dispatch at minimum cost.

Conventionally, AGC employ the static optimization techniques for secondary dispatch. This technique does not take in account the operating constraints of generating units and re-dispatches the power plants with pre-defined participation factors. This approach cannot foresee the present loading of units and may affect the response capability of generating unit. On contrary, this study employs a dynamic dispatch approach. It enables the AGC with better allocation of regulating reserves from CHPs and WPPs, while taking the available reserves, dispatch limit and generating cost in account.

4.3.1 Secondary dispatch strategy between CHPs and WPPs

The secondary dispatch is a classic mathematical optimization problem where the goal is to obtain an optimum allocation of power output among the available generators with given constraints. The sum of the secondary dispatch from the available generators must equal the power imbalance. Traditionally conventional power plants provide the secondary frequency control in real-time operation. However, the increasing wind power integration may require active participation from WPPs in secondary frequency control in future power systems along with conventional power plants. A coordinated AGC dispatch between conventional power plants and WPPs is therefore of high priority for operational security and stability.

In this study, the AGC dispatch strategy is developed in the most general case so that it is adaptable to all situations. The dispatch strategy considers certain constraints while deciding the secondary dispatch from participating generating units. These constraints typically take the form of minimum and maximum generator outputs, available reserves, dispatch limits and generating cost. It is worth mentioning that the dispatch strategy doesn't include the transmission constraints while deciding the secondary dispatch. This is because that each part of Danish power system is modelled as a single bus and aggregated models are used for the generating units with same technology, thus ignoring the transmission losses and the transmission constraints within the power system.

Putting the aforementioned discussion in the format of an optimization problem, the mathematical model directly follows with separate sets of equations for the positive and negative dispatch. The process involved during positive dispatch is described in (24) to (29), when system generation is less than the load demand. Similarly for down regulation process, (30) to (34) defines the negative dispatch. These sets of equations identify the constraints while deciding the real-time dispatch with minimum cost.

$$\text{minimize } C = C_{P_{WPP}} \cdot |\Delta P_{WPP}| + C_{P_{CHP}} \cdot |\Delta P_{CHP}| \quad \because \text{positive dispatch cost} \quad (24)$$

Subject to

$$\Delta P \geq 0 \quad (25)$$

Wind Power Plant System Services

$$\Delta P_{CHP} \leq \Delta P_{CHP_UpLim} \quad (26)$$

$$P_{CHP} \leq P_{CHP_max} \quad (27)$$

$$\Delta P_{WPP} \leq P_{WPP_avail} - P_{WPP} \quad (28)$$

$$P_{WPP} \leq P_{WPP_avail} \quad (29)$$

$$\text{maximize } C = C_{P_{WPP}} \cdot |\Delta P_{WPP}| + C_{P_{CHP}} \cdot |\Delta P_{CHP}| \quad \because \text{negative dispatch cost} \quad (30)$$

Subject to

$$\Delta P < 0 \quad (31)$$

$$\Delta P_{CHP} \geq \Delta P_{CHP_LowLim} \quad (32)$$

$$P_{CHP} \geq P_{CHP_min} \quad (33)$$

$$P_{WPP} \geq P_{WPP_min} \quad (34)$$

where,

$C_{P_{WPP}}$ = Power generation cost from WPP

$C_{P_{CHP}}$ = Power generation cost from CHP

ΔP_{WPP} = secondary dispatch from WPP

ΔP_{CHP} = secondary dispatch from CHP

P_{WPP_min} = minimum generation level of WPP

P_{WPP_avail} = maximum generation level of WPP

P_{CHP_min} = minimum generation of CHP

P_{CHP_max} = maximum generation of CHP

ΔP_{CHP_UpLim} = upper dispatch limit of CHP

ΔP_{CHP_LowLim} = lower dispatch limit of CHP

It is to be noted that to minimize the dispatch cost, cost function has to be minimized for the positive dispatch and maximized for the negative dispatch, so that required power is generated from low cost generating unit i.e. WPP. As it is aforementioned, that in this study, an aggregated models for CHPs and WPPs are used, therefore the dispatch process is performed on an aggregated model and a single cost function (linear) for each power plant is considered in this course. The dispatch process also takes the generating and dispatch limits in account. The secondary dispatch for the CHP is limited to ± 90 MW, as it is the case for the AGC acting on the border of Western Denmark with Germany and the dispatch for the WPP is limited to their minimum generation level and available wind power.

4.3.2 Secondary dispatch Process

The main factor deciding the secondary dispatch for the participating power plants is the availability of wind power. Usually, the system operator wants to use all available wind energy. This is because that wind power, the cheapest source for electricity production, is lost if kept as reserve and not used for secondary control purposes. Moreover, the incremental cost forming the basis for ED is very little with WPPs. On the other hand, TSOs of largely wind power integrated power system must account for the reserve to deal with the power imbalances owing to wrong forecast of wind power. The wind power is kept as reserve by operating the WPPs in delta mode.

In this study, the above set of equations decides the secondary dispatch to minimize the power imbalance, depending on the availability of wind power reserves. For-example, if the WPP generates the available wind power ($P_{WPP} = P_{WPP_avail}$), than during positive secondary dispatch only CHP will participate. However, during negative secondary dispatch, as $C_{P_{WPP}} \ll C_{P_{CHP}}$, the wind power is down regulated only when CHP is unable to follow AGC command. Otherwise, the WPP will generate its maximum available power. The dispatch operation in this scenario is shown in Figure 29. This assumption is useful for the situation when WPP are generating highly and the conventional power plants are running on their lower level.

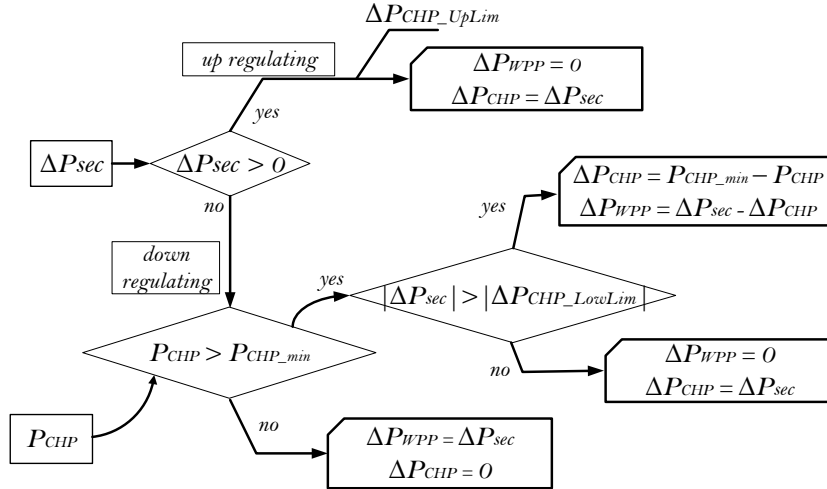

Figure 29: Secondary dispatch process when WPPs generates the available power

From Figure 29: the WPP is down regulated only when the output of AGC is negative, i.e. $\Delta P_{sec} < 0$, while the CHP provides secondary response for positive or negative value of ΔP_{sec} . For down regulation, the WPP will receive reference power signal only when CHP generation touches the lower generation limit (P_{CHP_min}) or ΔP_{sec} reaches to ΔP_{CHP_LowLim} , i.e. -90 MW. However, in case of up regulation, i.e. $\Delta P_{sec} > 0$, only the CHP provides the secondary support, as the WPP is already generating the available wind power.

Conversely, if the TSO keeps wind power as reserve, than during positive dispatch these reserves will be used first, as $C_{P_{WPP}} \ll C_{P_{CHP}}$, and then the regulating power will be activated from CHP. In this way the dispatch cost is kept at its minimum while reducing the real-time power imbalances. Figure 30 summarizes the secondary dispatch process, if wind power is kept as reserve.

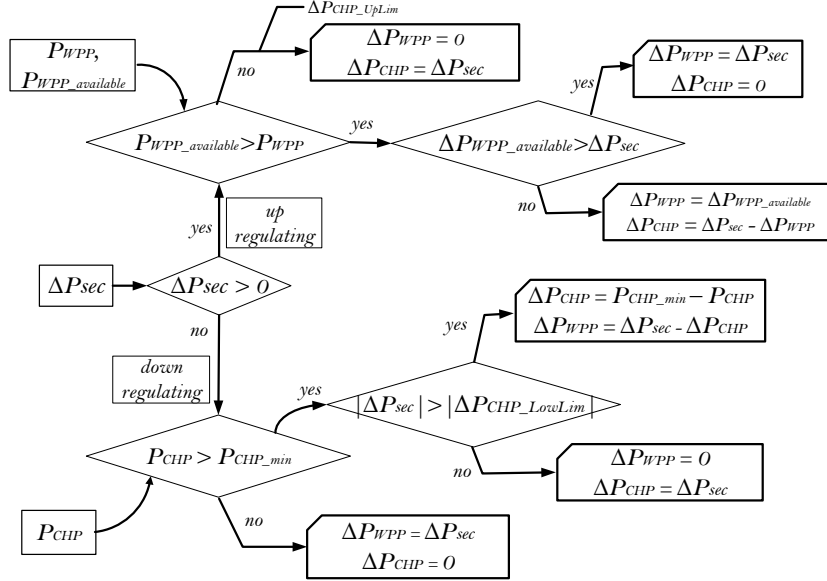

Figure 30: Secondary dispatch process when wind power is kept as reserve

The down regulation process is same as explained for Figure 30. However, during positive dispatch, i.e. $\Delta P_{sec} > 0$, the wind power kept as reserve is initially activated ($\Delta P_{WPP_available} = P_{WPP_available} - P_{WPP}$) and afterwards the remaining power imbalance is reduced by regulating the CHP production.

4.4 Rolling balance – activation process for manual reserves

The manual reserves are activated to relieve the automatic reserves and to minimize the sustained power imbalances. These reserves are primarily used to restore the automatic reserves in a balanced system situation, but it is also activated after larger incidents to restore the system frequency and consequently free the system wide activated primary reserve. These reserves are allocated in a manner that the overall generation cost can be reduced while relieving the automatic reserves.

Energinet.dk uses NOIS list for the activation of regulating power bids where bids are sorted with increasing prices for up-regulation and decreasing for down-regulation. The control room operator activates the bids with the cheapest regulating power, keeping transmission constraints and market rules in account. For-example, for activation of regulating the minimum activation time is 30 minutes and bid level shall be of minimum 10 MW.

The balance responsible after receiving bid activation signal should be able to ramp up or down their production within specific time limits. Figure 31 describes the different time intervals for bid activation [8], where activation time is defined as lead time plus ramping time. The time interval when system operator calls for the bid activation and the regulation starts is called the lead time. In Denmark, the lead time is one minute for directly activated bids and five minutes for bids ordered through plans. In Figure 31, the ramping time is the time needed for full bid activation while running time is normally defined as the time from the start of the regulation till the end of the activation.

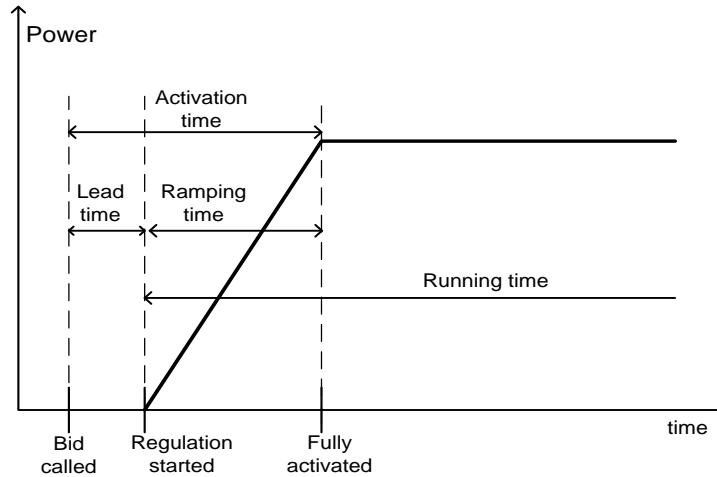

Figure 31: Example of regulating bid activation time intervals

The activation of regulating power bids depends on the control room operators' response. Different people that are in charge of balancing the power in the control room do not react the same way. For the purpose of this project, a heuristic algorithm named as '*rolling balance*' is developed for this study. The rolling balance is designed to simulate the actions similar to the control room in order to activate the regulating power bids within the real-time for balanced power system operation, while ensuring that it shouldn't overreact to the imbalances as it might lead to power imbalance in an opposite direction.

Rolling balance uses the outputs of Simba for the calculations of power imbalance by taking into account the HA schedule for conventional generation and power exchange (import and export power), available wind power generation and load demand, which is assumed to be equal to the HA forecast. The power imbalance is calculated as:

$$P_{\text{imbalance}} = P_{\text{conventional_HA}} + P_{\text{Imports_HA}} - P_{\text{Exports_HA}} + P_{\text{WPP_avail}} - P_{\text{Load}} \quad (35)$$

The *rolling balance* uses the power imbalance in (35) as an input time series and will activate the regulating bids to alleviate the imbalances as effectively as possible. Before activating the regulating bids it has to ensure that the imbalance is greater than the threshold level and persistent as well, so that the algorithm does not react excessively. In this study, if the power

imbalance is greater than the 30 MW and persists for 15 minutes (i.e. three 5 minutes period), the *rolling balance* will activate the regulating bid equal to the minimum of the power imbalance in the start of third period, i.e. after the AGC response. The following rule is applied in activating the regulating bid:

$$\text{if, } \Delta p(i) > \varepsilon \ \& \ \Delta p(i - 1) > \varepsilon \ \& \ \Delta p(i - 2) > \varepsilon$$

$$\Rightarrow \text{activate bids equal to min } (\Delta p(i), \Delta p(i - 1), \Delta p(i - 2))$$

$$\text{else, } \Delta p(i) < -\varepsilon \ \& \ \Delta p(i - 1) < -\varepsilon \ \& \ \Delta p(i - 2) < -\varepsilon$$

$$\Rightarrow \text{activate bids equal to max } (\Delta p(i), \Delta p(i - 1), \Delta p(i - 2))$$

where ε is the threshold level and $\Delta p(i)$ is the power imbalance at time period 'i'. If the imbalance in the first group of points met the aforementioned criteria, the regulating bid equal to the smallest power imbalance of the three consecutive points is activated with a ramp rate of 30 MW/min and the new points are checked. If the second group of points is also found to meet the criteria, then again the regulating bid is activated. But if one of these points does not meet the criteria, then the regulating bid is not activated. Figure 32 shows the process for the activation of regulating power.

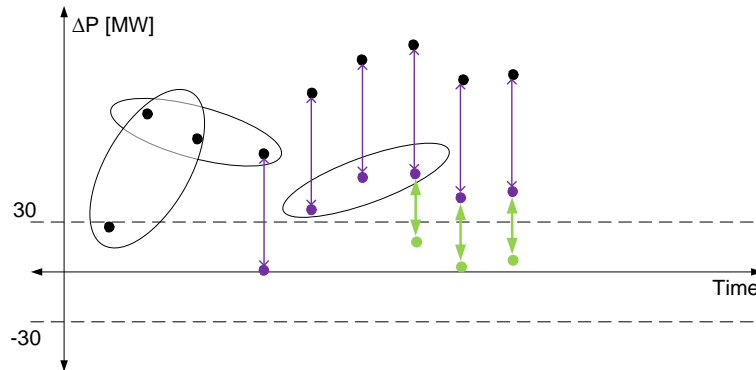

Figure 32: Example of regulating bid activation by post processing

The coordination between the power balance control schemes which involves the activation of FCR, FRR and RR is demonstrated in Figure 33, where primary response, AGC response and *rolling balance* are timely disassociated. Following the power imbalance, the power plants equipped with the speed governors provides the initial support by releasing the primary reserves within 30 seconds. Afterwards, the AGC provides the secondary control by ramping the power generation from the participating power plants. The response of the AGC depends on the time delays associated with the AGC system, CHPs and WPPs. In this study, the secondary response is provided within 8 – 10 minutes. The *rolling balance* activates the regulating power at the start of third period (10th minute), if the power imbalance is persistent for three periods and greater than threshold level.

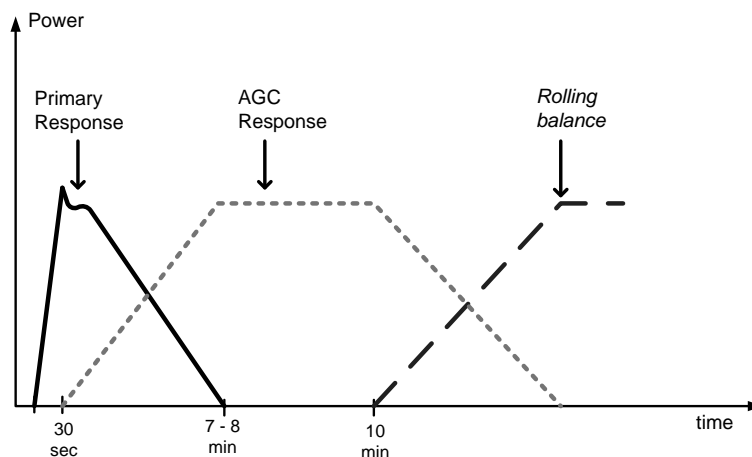

Figure 33: Activation periods for real-time operating reserves in this study

4.5 Summary

Over the years, the active power balance control is getting more significant for the system operators due to the dramatic increase of electrical power generation from the wind power. In this context, the hour-ahead regulating power plan with reduced planning horizon efficiently addresses the intermittent wind power and reduces the regulation burden that would be required in a dispatch plan of one hour. The SimBa model provides the balanced regulating power plan, in a five minute resolution, for generation and power exchange with neighbouring power systems. The HA balanced power plan is developed based on the information from DA market model and the wind power forecast model. However, wind power forecast errors and other events might cause a power imbalance in the real-time, which can be controlled through AGC and activating extra regulating bids from the control room.

This chapter proposes and presents a novel and practical approach for integration of wind power into the AGC of power systems to compensate the power imbalances between demand and generation in a real-time. It is based on a coordinated control strategy between CHPs and WPPs. The coordinated control strategy improves the active power balance in the power system with minimum secondary dispatch cost. The control strategy regulates the active power production from CHPs and WPPs, depending on operating reserves, dispatch limit and the generating cost. The WPPs can provide up or down regulation services, depending on their operation mode and availability of wind power reserve.

This chapter also develops an algorithm for the activation of regulating power bids. The algorithm named as ‘rolling balance’ emulates the control room response while activating the regulating power for secure power system operation. The algorithm effectively activates the regulating power bids in a highly wind power integrated power system, thus increases the system reliability and ensures the power supply security.

Chapter 5

Component modelling

To study the active power balance illustrated in Chapter 4, this chapter develops and analyses the generating unit models and system interconnections for future Danish power system. Aggregated models of the power generating units, developed for long term dynamic simulation studies, are neither too complex which makes the simulations time consuming and nor too simple to reduce the results reliability. The simplified models reduce the computation effort but still contain the dynamic features relevant for specific application.

This chapter initially models the system interconnection for future Danish power system where external grid provides power frequency characteristics and inertia of the electrically connected power system. Then, an aggregated CHP model is developed to examine the dynamic features of a CHP power plant in long term dynamic simulation studies, which may affect the system stability due to its slow boiler response. The model consists of a thermal boiler, a boiler turbine controller, a steam turbine and a speed governor and contains the primary and secondary control capabilities. The aggregated generic model for the DCHP power plant follows next, where gas turbine dynamics depict the physical restriction on turbine response. Also, an aggregated WPP model, simplified for the active power control purpose, is developed. The WPP model includes the relevant dynamics for long term simulation studies and is capable of providing the targeted ancillary services, i.e. primary and secondary control. The performance of the developed models are also analysed individually in this chapter.

5.1 System interconnections

System interconnections play an important role in the power balance control of the highly wind power integrated power system. As mentioned in Chapter 3, the Danish power system is strongly connected to its neighbouring power systems. The Eastern Denmark is synchronized with Nordel power system through Sweden and has an HVDC connection with Germany. The Western Denmark is synchronized with CE and has HVDC connections with Sweden and Norway. The two areas are also connected through a 600 MW DC connection across the Great Belt. However for future goal, when 50% of the total electricity has to be supplied by wind power, the Danish TSO is increasing some of the existing interconnections capacities and also building new HVDC

link with Holland. The planned system interconnections for the future Danish power system are provided in Table 3 and Table 4.

Table 3: Planned system interconnection capacities for the year 2020; Eastern Denmark

System interconnections	HVDC		AC
	GBL	Germany	Sweden
Capacity (MW)	600	600	1700

Table 4: Planned system interconnection capacities for the year 2020; Western Denmark

System interconnections	HVDC				AC
	GBL	Sweden	Norway	Holland	Germany
Capacity (MW)	600	740	1640	700	2500

This section initially identifies the limitation on power exchange ramp rates with Nordic and CE power system and its effect on the Danish power system and then provides the modelling description of interconnections for dynamic simulation studies, where the external grid emulates the power frequency characteristics and the inertia of the interconnected power system.

5.1.1 Power exchange ramp rates

The hydro dominated Nordic power system exchanges power in 15 minute resolution and the CE power system, dominated by thermal, nuclear and wind power, follows an active power exchange schedule with 5 minute resolution. The Nordic power system is required to ramp the agreed power exchange in 30 minutes and begins 15 minutes before the agreed exchange hour. Meanwhile, in the CE power system, the power exchange is ramped in 10 minutes and start 5 minutes before the agreed exchange hour. Figure 34 and Figure 35 shows an example of ramping on the interconnections in Eastern and Western Denmark, respectively.

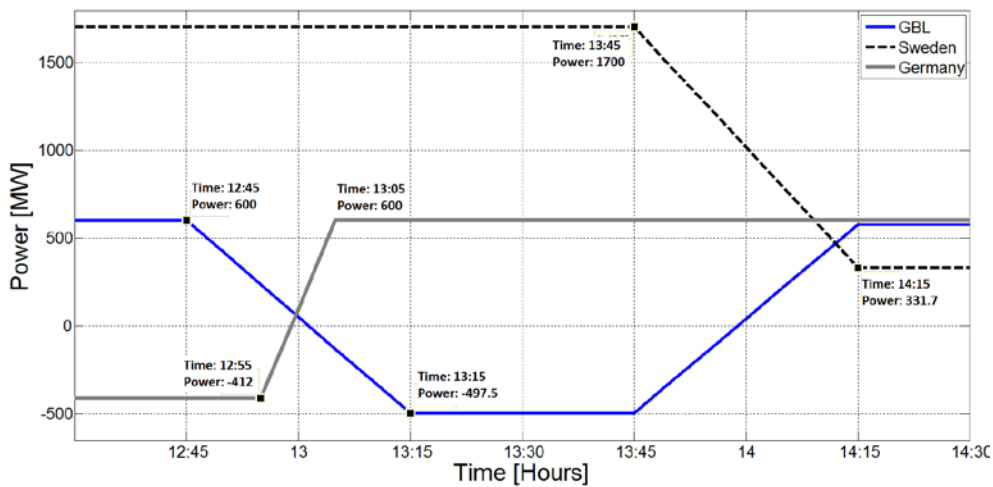

Figure 34: Power exchange ramping on an agreed hour; Eastern Denmark

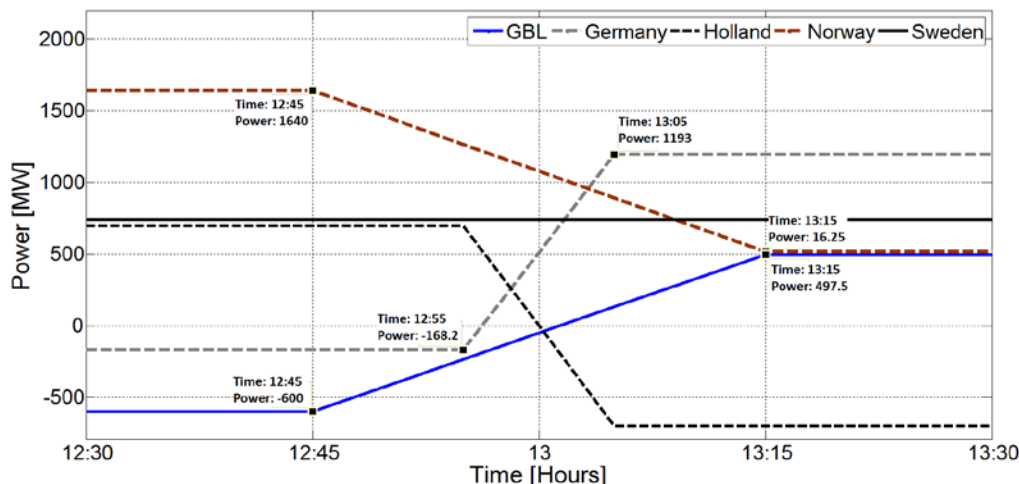

Figure 35: Power exchange ramping on agreed hour; Western Denmark

The figures shows the start time, end time and ramping duration of power exchange at an agreed hour. It can be seen that the power exchange with Sweden and Norway and on the GBL is ramped in 30 minutes and starts 15 minutes before an agreed hour. On contrary, the power exchange with Germany and Holland starts 5 minutes before an agreed hour and is ramped in 10 minutes. If the power has to be transported from the Nordic power system to the CE power system or vice versa, the agreed power exchange is ramped in different durations and at different starting times. This power transport might lead to a power imbalance in Danish power system at an agreed hour which can be dealt by activating an extra regulating bid.

5.1.2 Modelling system interconnection

As aforementioned, this study assume that the neighbouring power system do not contribute in power balancing operation; except for the primary response which depends on the power frequency characteristics of the synchronous power system. Therefore, the study models the system interconnections as simple load model, where import power is seen as a negative load and the export power as a positive load. The power exchange on these interconnections follows the hour-ahead plan from SimBa. However, to study the dynamic on AC interconnections, following a power mismatch, an external grid is modelled as a slack bus. The model of AC interconnection is shown in Figure 36, where primary response from the interconnected power system can be seen as the power deviations ($\Delta P_{\text{exchange}}$). The summation of the planned power exchange and the deviation on external grid is the power transacted on AC interconnection.

The external grid model offers the inertia and the frequency response of the Nordic and CE power systems. In this study, external grid has an inertia of 16 seconds and activates FCR with 6000 MW/Hz and 15000 MW/Hz in Eastern and Western Danish power systems, respectively [64].

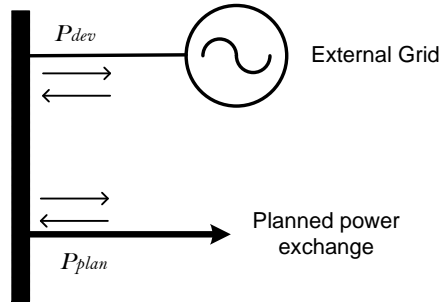

Figure 36: AC interconnection model

5.2 Combined heat and power plant (CHP)

An aggregated model of a CHP unit is needed for long term dynamic simulation studies that can examine its dynamic features during active power balance control, which may affect the system stability due to the slow boiler response. This section presents the development of an aggregated CHP model that can estimate the system response with respect to active power balance control.

5.2.1 Modelling CHP unit

The modelling of any generating unit in the power system studies depends on the intended study. The generic diagram of a CHP unit developed for this study is shown in Figure 37. The model is used for long term dynamic simulation studies, considering the primary and secondary control capabilities of the power plant along with its boiler dynamics. The performance of a CHP unit depends on the type of plant, boiler controller characteristics and operational mode which affects the steam turbine response during dynamic performances. However in this project, the model is simplified for long term dynamic simulation studies and is developed based on studies in [65, 66, 8, 6]. The controllers for steam turbine and boiler turbine are also simplified for long term dynamic simulations. The simplified model consists of a thermal boiler, boiler turbine controller, steam turbine and the speed governor.

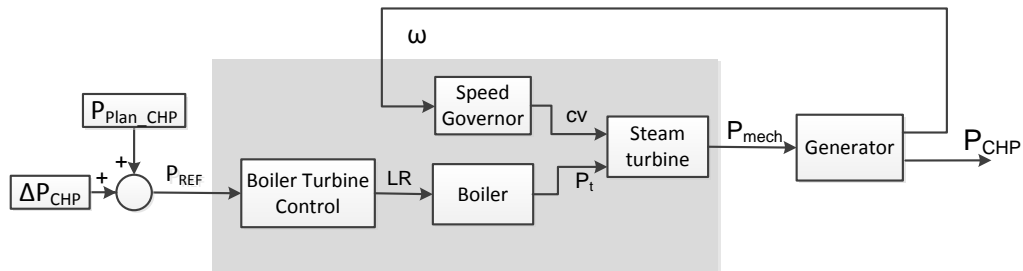

Figure 37: Generic CHP model

The simulation model is simplified to reduce the calculation effort but keeping the essential capability of the system to predict the units influence in long term dynamic simulation studies. The mechanical input (P_{mech}) to the generator is defined by steam turbine block as a function of control valve position (cv) and main steam pressure (P_t). The P_{mech} drives the synchronous

generator. The primary response of the power plant is provided by the speed governor. The response is based on the generator speed variation and the droop settings which adjusts the valve position. The boiler model introduces time delay for a change in the load reference set point (LR), the output of boiler turbine control, and appears as P_t . The boiler turbine control block develops the LR based on active power set point from SimBa (P_{plan}) and delta active power reference from AGC.

I. Boiler Turbine Control

The boiler turbine control model, shown in Figure 38, is designed to form LR. The LR drives the turbine valve to match the actual generation with the desired generation and provide a feed forward signal to the boiler.

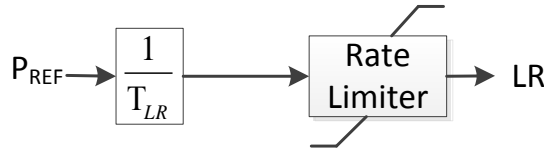

Figure 38: Boiler Turbine control

The output power rate from turbine is limited due to the thermodynamics and mechanical constraints, known as generation rate constraint (GRC) and steam temperature control. The GRC and steam temperature control is not directly added to the model, but the rate limitation is added in this regard. If these constrains are not followed it might result in excessive wear and tear of controller [6]. In this study, the ramp rate is limited by 30 MW/min. It is important to mention that boiler turbine control is inactive when P_{plan} is provided by SimBa, as it takes in account the generating unit ramp rates while activating the hour-ahead regulating power plan.

II. Speed Governor

The general obligation on speed governor is to respond when frequency deviates from its nominal level, i.e. to provide primary response. The frequency deviation is sensed as a change in the synchronous generator speed. The speed governor control is very specific to the turbine type. However, a very generic model for speed governor is used in this study. Any speed deviation due to the power mismatch is converted to power deviation through a closed loop system depending on the droop characteristic. The input to the turbine governor is the generator speed while output is the steam valve flow area.

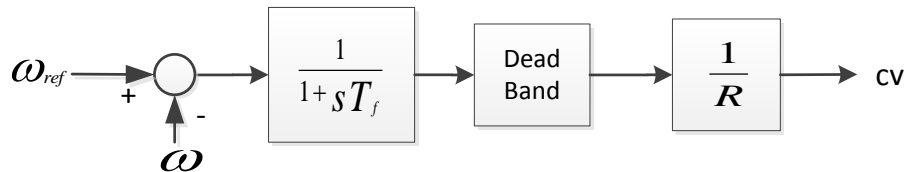

Figure 39: Generic model of a speed governor for a CHP unit

A dead-band in the speed governor is added due to mechanical imperfection to avoid excessive movement of the steam valve for any small speed deviations. A control signal is generated for any speed deviation higher than the predefined values of the dead band. The dead band should not affect the steady state frequency. The parameters used in governor model are provided in the Appendix.

III. Boiler model

The simplified boiler model, as shown in Figure 40, is developed for long term dynamic simulation based on the study in [66]. It takes into account the practical limits of turbine output and delays associated with stored steam energy in the boiler. The series of equivalent lumped storing steam at internal pressure is labelled as b_1 , b_2 and P_t . The time delays associated with boiler model can change significantly the time response of the power and frequency.

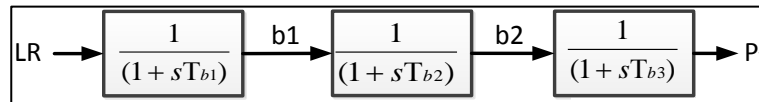

Figure 40: Boiler Model

The time constants associated with steam boiler are identified as T_{b1} , T_{b2} and T_{b3} and they dominates the smaller time constants in the CHP model. These time constants are taken from [67] and are shown in Appendix. The overall response the boiler is usually in the range of 5 – 6 minutes and tends to lead the response of the turbine power output.

IV. Steam turbine model

Steam turbine converts stored energy of high pressure and high temperature steam into mechanical energy. Steam turbine consists of a set of moving blades attached to the rotor and a set of stationary vanes. The high velocity steam accelerated by stationary vanes is converted into shaft torque by moving blades. The steam turbines varies from non-reheat, tandem compound single and double reheat to cross compound single and double reheat. The steam flow in all compound steam turbine is controlled through governor controlled valves at the inlet of high pressure turbines. The delays between valve movement and change in steam flow are introduced due to steam chest, inlet piping to the first cylinder and re-heater and cross over piping. These delays are accounted in modelling steam turbine for system stability studies. This study models the cross compound double reheat steam turbine based on the study found in [65, 66] and is shown in Figure 41; where the mechanical power is defined as a function of P_t from boiler model and c_v from speed governor.

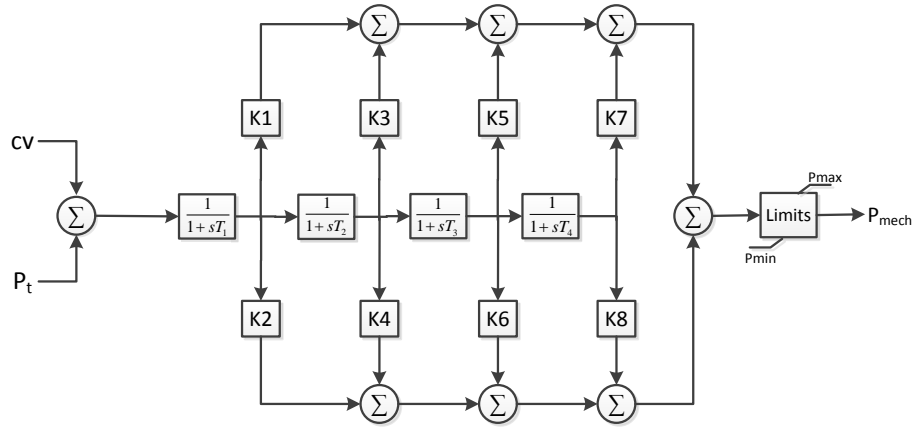

Figure 41: Steam Turbine

The four time constants in above figure decide the steam turbine response. These time constants represent the charging of various volumes; T_1 is the time constant associated with high pressure turbine bowl, T_2 with the re-heater, T_3 with crossover and T_4 for double re-heat units. The coefficients $K1$ to $K8$ determine the contribution from various turbine sections such as very high pressure, high pressure, intermediate pressure and low pressure. These coefficients represent the contribution to the total mechanical power by various turbine sections. $K1$ and $K2$ are very high pressure turbine coefficients, $K3$ and $K4$ are the high pressure turbine coefficients, $K5$ and $K6$ are the intermediate pressure turbine coefficients and $K7$ and $K8$ are the low pressure turbine coefficients [67].

V. Thermal power plant Operation mode

The overall behaviour of thermal power plant is determined by boiler control system. This is the master control signal that defines the set points for the rest of the system. All the main control loops must respond to a central command and sets their set points. Different ways of controlling thermal power plants is discussed below with the behaviour of master control signal [68].

a. Boiler following mode

The change in generation is initiated by turbine control valves when steam turbine operates under boiler following mode or turbine leading mode. The steam turbine has full access to the stored energy in the boiler. The change in steam turbine initiates by means of fast acting governor valves for any small change in the load demand. The boiler then responds to any change in steam and pressure from the set point by changing its firing rate. Operating in this control mode provides quick primary reserves, but throttling of governor valves reduces the available steam flow and leads to energy losses making this operation mode less efficient. This mode of operation is also called ‘constant pressure’ mode.

b. Turbine following mode

In turbine following mode or boiler leading model, the boiler controls the generation through combustion while the governor valves act as relief valves to maintain a set pressure. The drawback is the slower generation response, as the steam flow and MW output closely follow steam production in the boiler. The position of governor valve is controlled by valve outlet pressure and not from the input as boiler following mode. In this operational mode, the unit can be operated with fully open governor valve. This operational mode is energy efficient as it allows units to operate continuously at their maximum but it does not offer any response to frequency deviation. Turbine following mode is preferred for power plants which continuously operate at their maximum capacity ratings e.g. nuclear plants.

c. Sliding pressure mode

Sliding pressure mode has the advantage of high efficiency and frequency compensation with variable steam pressure mode. The steam pressure is the function of unit load rather than a constant value. The variable pressure operation provides faster unit loading and enables the unit to operate at lower temperature and pressure. The boiler controls the generation by ramping up or down the steam supply. However, this restricts the units' ability to use stored boiler energy for meeting the short term demands. It is essentially a turbine following mode of operation. The valves are fixed in predefined optimum position, either at sequential valve point or fully open. Frequency compensation is provided by slow boiler control when valves are fully open, but it can respond to any frequency deviation for optimum position less than fully open. The reduced throttling action of governor valve at lower outputs leads to improved unit efficiency.

In this project, the thermal power plants are assumed to operate in sliding pressure mode. The valves are not fully open and governor can respond to any frequency deviation by releasing the reserves. The reserves are then restored by varying the steam pressure through boiler controller.

5.2.2 Model performance – CHP power plant

In the following, a set of simulations are carried out to illustrate and evaluate the performance of a CHP unit, developed and implemented for long term dynamic simulation studies. These simulations evaluate the active power control capabilities of CHP power plant. The boiler dynamic and ramp rate limitations affect the active power control capabilities. The performance of the generating unit is tested in presence of an external grid, which offers inertia and power frequency characteristics of the Nordic power system. The network layout for the simulations of the CHP power plant is shown in Figure 42.

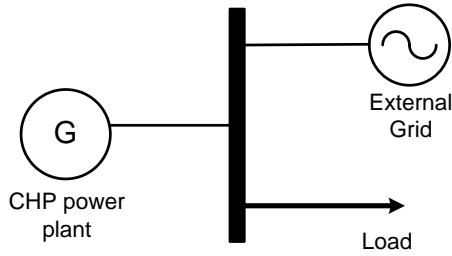

Figure 42: Network layout for evaluating CHP performance

The external grid has inertia of 16 seconds and activates FCR with 6000 MW/Hz. The generating unit has the capacity of 1754 MW, i.e. capacity of an aggregated CHP power plant in Eastern Danish power system used in this study. It is assumed that the power system model is initially balanced at 1 pu with the load of 1754 MW.

The dynamic performance of CHP model is evaluated for long term dynamic simulations through two study cases. The response of generating unit for steps in reference power with regard to boiler dynamics and ramp rate limitation is carried out in first case. The second case evaluates the primary and secondary response for a load step with the inclusion of AGC.

a. Steps in reference power

The response of a CHP unit for negative and positive step in reference set point is shown in Figure 43. The power set point is stepped by 0.1 pu (174.5 MW) for every 20 minutes. The power set point is first stepped down from 1 pu to 0.5 pu and then stepped back to 1 pu. The figure shows that the CHP unit responds in 7 – 8 minutes to a 0.1 pu step in reference power. The response mainly depends on the boiler response and the ramp rate limitation of the generating unit, as boiler responds in 5 – 6 minutes, while boiler turbine controller ramps the reference power with rate of 30 MW/min.

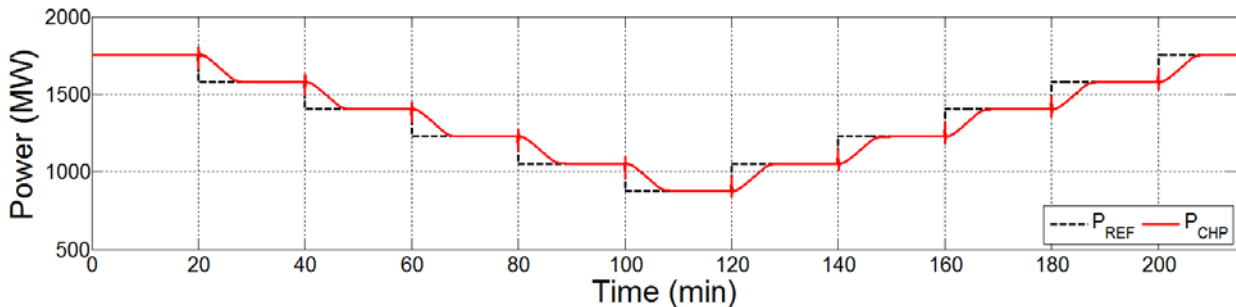

Figure 43: CHP unit response to the steps in reference power

The response of boiler turbine controller, boiler and steam turbine is also individually evaluated in Figure 44, when reference power is stepped from 0.8 to 0.9 pu. From Figure 44 (A), the boiler turbine controller ramps the power of 175.4 MW in 5.85 minutes with the rate of 30 MW/min. Figure 44 (B) presents the steam flow with different time constants in the boiler, where LR is the

input from boiler turbine control and P_t (main steam pressure) is the input to the steam turbine. The response of lumped storing steam (b_1 , b_2 and P_t) depends on the boiler time constants, i.e. T_{b1} , T_{b2} and T_{b3} . The delay between P_t and P_{mech} is shown in Figure 44 (C). The delay is introduced by the steam turbine and represents the delays due to steam chest, inlet piping to the first cylinder and re-heater and cross over piping in steam turbine system. From this figure it can be observed that dynamic behaviour of boiler and the ramp rate limiter mainly influences the power plant response.

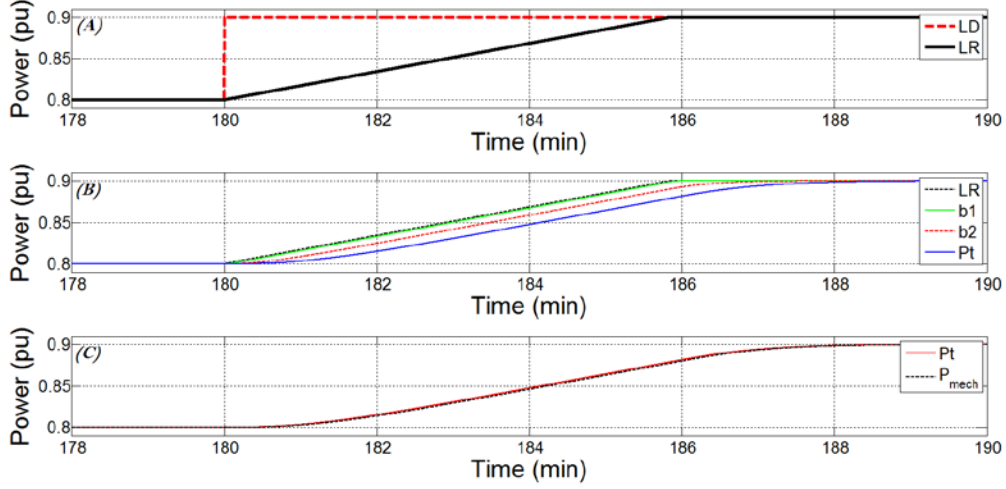

Figure 44: Response to a step in reference power; (A): boiler turbine controller, (B): steam turbine, (C): steam turbine

b. Active power control capabilities of aggregated CHP model

The speed governor provides the primary response and depends on the droop characteristic and operating conditions of the generating unit. The primary reserves activated in this process and the system frequency is then restores through secondary response, where AGC depending on the amount of power imbalance assigns new set points for the participating generating units.

To evaluate the active power control capabilities of CHP unit, a load step of 175.4 MW (0.1 pu) is applied. The step in load will change the system frequency depending on the power frequency characteristics from the external grid and the CHP unit:

$$\beta_{PS} = \beta_{grid} + \beta_{CHP} \quad (36)$$

$$\text{where, } \beta_{CHP} = \frac{P_{CHP}}{R \times f} = \frac{1754}{0.04 \times 50} = 877 \text{ MW/Hz} \quad (37)$$

$$\rightarrow \beta_{PS} = 6000 + 877 = 6877 \text{ MW/Hz} \quad (38)$$

The steady state frequency of the system is then calculated as:

$$\Delta f_{ss} = - \frac{\Delta P_{load}}{\beta_{PS}} = - \frac{175.4}{6877} = - 0.0255 \text{ Hz} \gg f_{ss} = 49.975 \quad (39)$$

The speed governor will detect the change in frequency as change in generator speed and will responds to it by releasing the primary reserves. The response from the external grid will appear as deviation from scheduled power exchange. The steady state primary response from CHP and external grid will be:

$$\Delta P_{CHP} = -\Delta f \times \beta_{CHP} = 22.4 \text{ MW} \quad (40)$$

$$\Delta P_{grid} = -\Delta f \times \beta_{grid} = 153 \text{ MW} \quad (41)$$

The dynamic response of the generating unit and the external grid for a load step is plotted in Figure 45 to Figure 47, where Figure 45 shows the system frequency response, Figure 46 shows the power deviation on external grid as a response from interconnected power system and Figure 47 shows the governor and CHP response.

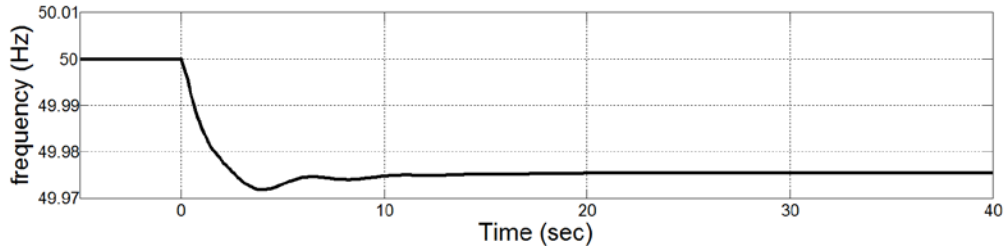

Figure 45: Frequency response for a load step

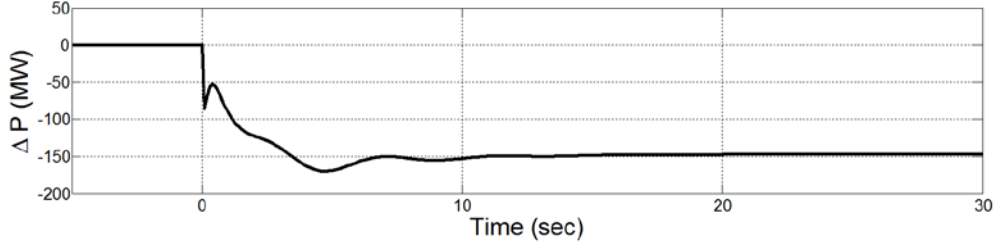

Figure 46: Power deviations on external grid

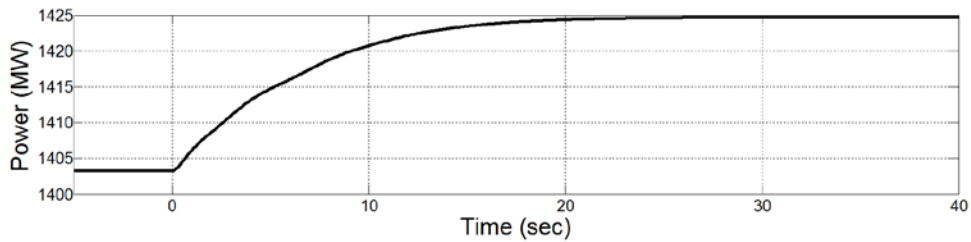
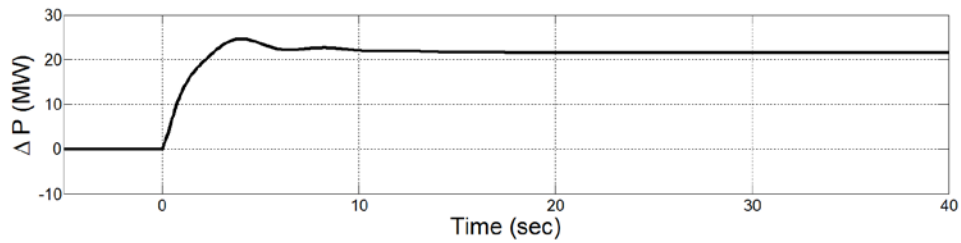

Figure 47: Load step response; top: speed governor, bottom: CHP response

It can be noted from above figures, that governor immediately responds to the frequency change; however, the activation of FCR from CHP is delayed due to the steam turbine response. The response from the interconnected power system is seen as power deviation on external grid and therefore appears in opposite direction. The inertia of the generating unit and the external grid limits the frequency change due to the sudden load step of 175.4 MW and their response bounds the steady state system frequency to 49.975 Hz.

The AGC controller implemented in previous chapter provides the secondary response to restore the primary reserves and the frequency to its nominal level. The AGC calculate the P_{ACE} using (10), where the bias setting of AGC (B) equals to the power frequency characteristics of the power system (β_{PS}). The required secondary response is calculated through (13). Figure 48 and Figure 49 respectively shows that the system frequency and the primary reserves are restored to their previous level. Figure 49 also shows the CHP response, when the required response is provided in 8 minutes. The AGC controlled response also restores the deviation on external grid, as shown in Figure 50.

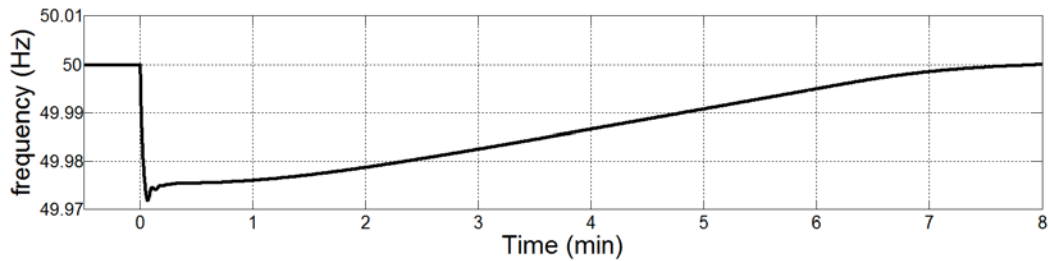

Figure 48: Secondary frequency response

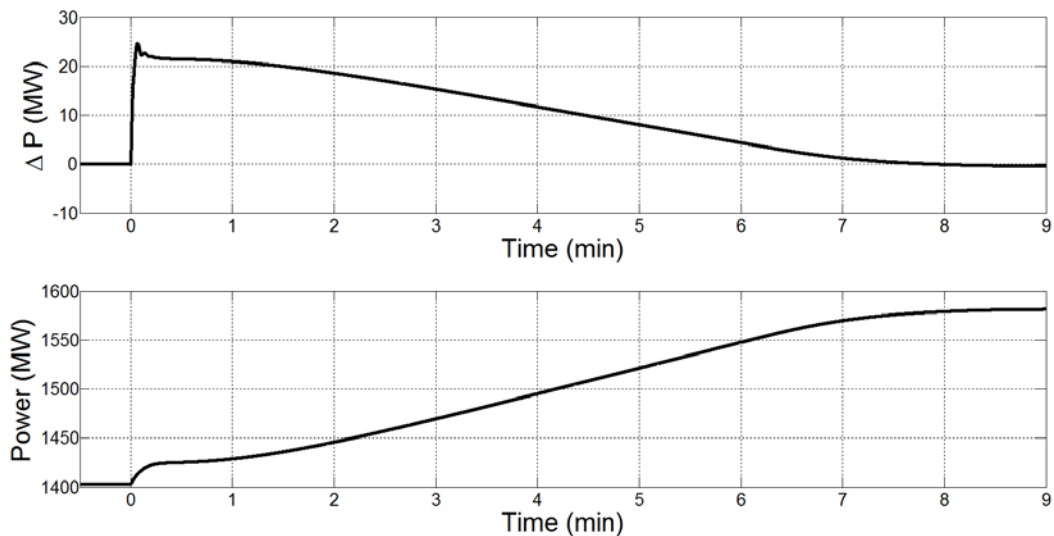

Figure 49: Secondary response with AGC, top: governor valve flow, bottom: CHP power

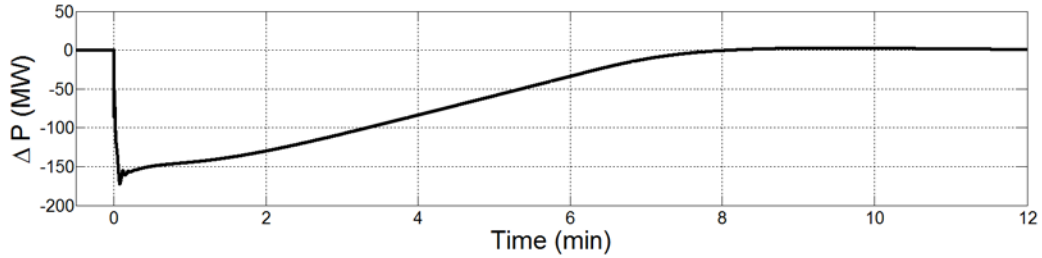

Figure 50: Power deviation on External grid after secondary response

The primary response from CHP unit starts instantly and the entire reserves are activated within 30 seconds, owing to the delays associated with the steam turbine. While, secondary response is provided in 8 min to restore system frequency, primary reserves and power exchange. The secondary response depends on the delays associated with the AGC system, boiler and steam turbine and also on the ramp rate limit imposed in the boiler turbine control.

5.3 De-centralized Combined Heat and Power plant (DCHP)

From Table 1 in Chapter 2, most of the DCHP units are based on the gas turbine technology. Therefore, this study models an aggregated model of DCHP units based on the gas turbine technology for long term dynamic simulation studies. The aim of this study is not to provide an analytical description of DCHP technology, but to examine the dynamic response of gas turbine in long term dynamic simulation studies that can affect the power balance control.

5.3.1 Modelling DCHP unit

An aggregated DCHP model is developed based on studies in [67, 6, 8, 14] and consists of a speed governor and a gas turbine. The generic model of DCHP units is shown in Figure 51. The model takes the hour-ahead plan from SimBa and provides the primary response through speed governor during real-time power imbalance.

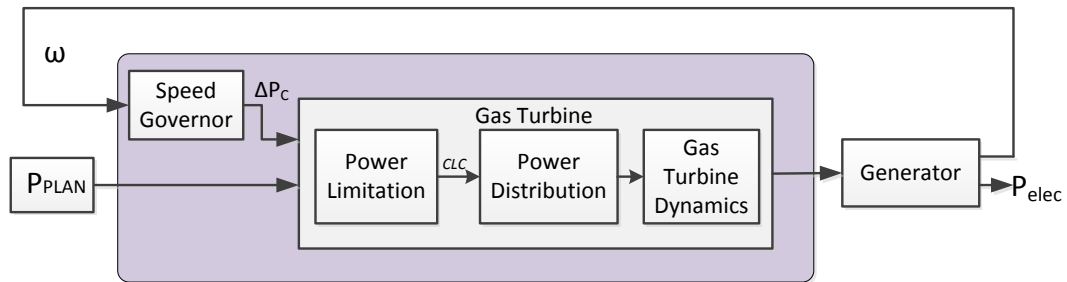

Figure 51: Generic DCHP model

As mentioned before, the purpose of this study is to examine the dynamic response of a gas turbine in long term dynamic simulation studies. Therefore, the model is simplified to reduce the computational effort but still maintain the capability to predict unit influence on system dynamic behaviour. The governor responds with power demand (ΔP_C) signal to the gas turbine, when

frequency deviates from its nominal value. The response depends on the droop characteristics of the generating unit. The gas turbine model defines the mechanical output power P_{mech} as a function of P_{PLAN} from Simba and ΔP_C from speed governor. The parameters for the DCHP unit are provided in appendix.

I. Speed Governor

Any imbalance between load and generation deviate the system frequency from its nominal value. The generating units equipped with speed governor responds to this frequency change by activating the FCR, to stabilize the system frequency to an acceptable level. The activation of these reserves depends on the governor droop characteristics and operating condition of the generating unit. The governor model for the DCHP unit is shown in Figure 52.

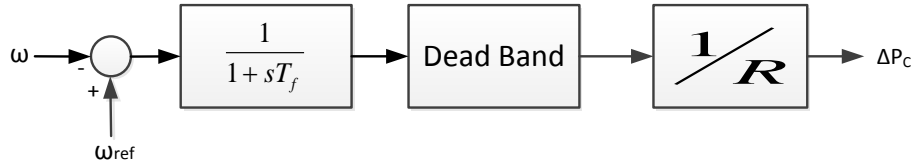

Figure 52: Generic model of a speed governor for DCHP unit

The low pass filter filters the high frequency deviation from the rotor speed. The dead band prevents the turbine from responding to small frequency deviations. Frequency deviance outside the dead band will generate the frequency error which is converted into power demand signal (ΔP_C) by the droop characteristics of speed governor. The power demand signal will then serves as input to the gas turbine.

II. Gas turbine model

The gas turbine model consists of power limitation block, power distribution block and gas turbine dynamics block, as shown in Figure 52. The gas turbine model defines the mechanical power input for the synchronous generator based on the power demand signal from speed governor and the reference power [67].

a. Power limitation

Power limitation block, shown in Figure 53, provides the physical restriction on turbine response based on the physical constraints of combustion technology. The P_{max} and P_{min} are the maximum and minimum power levels to which the reference power is restricted. The ‘min’ block is the low value gate which selects the minimum input value and ‘max’ block is the high value gate that chooses the higher input value. The power demand signal and the reference power signal serves as an input to the power limitation block.

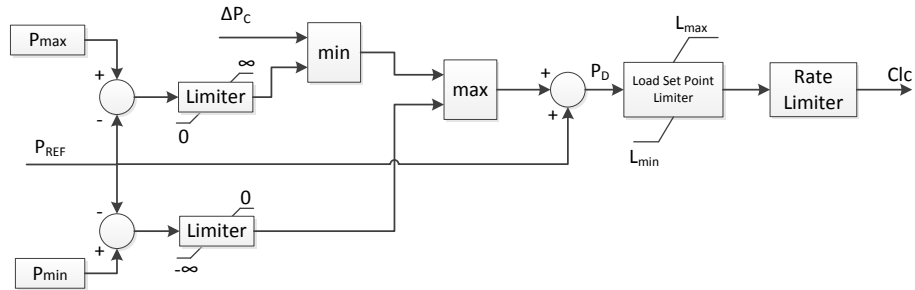

Figure 53: Power limitation block of gas turbine

The load set point limiter limits the power demand signal (P_D), making sure that technical constraint of combustion is not violated. L_{max} is the maximum load set point and L_{min} is the minimum load set point. The ramping of power demand signal is limited at a particular rate by a rate limiter block. The rate limiter prevents the excessive firing during ramping up and extinguishing of thin combustion flame in case of steep ramping down. The command load change signal (CLC) from power limitation block is then directed to the power distribution block.

b. Power distribution

The power distribution block of the gas turbine is shown in Figure 54. It has two combustion chambers which are fired in series. The compressed air enters into the environment combustion chamber (EV), where it is heated and mixed with 50% of the total fuel. The fuel flow depends on the CLC signal, and the airflow depends on the shaft speed and variable inlet guide vane (VIGV). The mixture after heating up expands through high pressure turbine and forces it to spin. It will cause the pressure to drop. The mixture is then directed to sequential environmental combustor (SEV) where 50% of the remaining fuel is added with some additional air. The new mixture after heating up is expanded through low pressure turbine to spin the turbine. This procedure has a superior operating flexibility, low emission and high efficiency.

The physical characteristics of fuel flow, air flow and allowable temperature are represented in control blocks by power contribution factor. CEV is the environmental combustor capacity factor, CSEV is the sequential environmental combustor factor, CVGV is the variable inlet guide vane position compressor factor and CFM is the base load function of ambient temperature, ambient atmospheric air pressure and shaft speed. In this study, CFM is set to 1 pu. The outputs SPEV, SPSV and SPVG are the power contribution factors and will depend on the capacities of two combustors, air compressor and CLC signal from power limitation block.

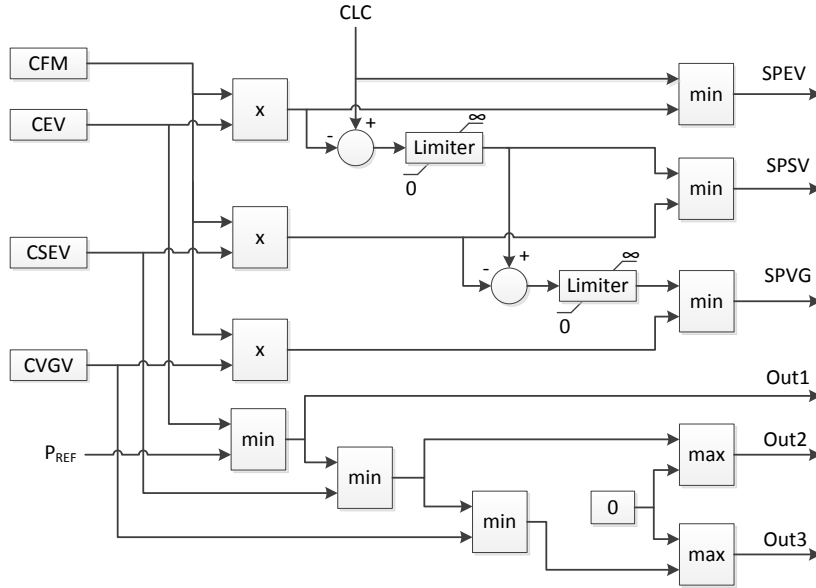

Figure 54: Power distribution block of a gas turbine

c. Gas turbine dynamics

The gas turbine dynamics is represented by the dynamics of the combustor and compressor units. The dynamics of environment and sequential environmental combustor are represented by first order lag function, while the dynamics of VIGV is represented by second order transfer function:

$$\frac{\omega_0}{s^2 + 2\zeta\omega_0s + \omega_0^2} \quad (42)$$

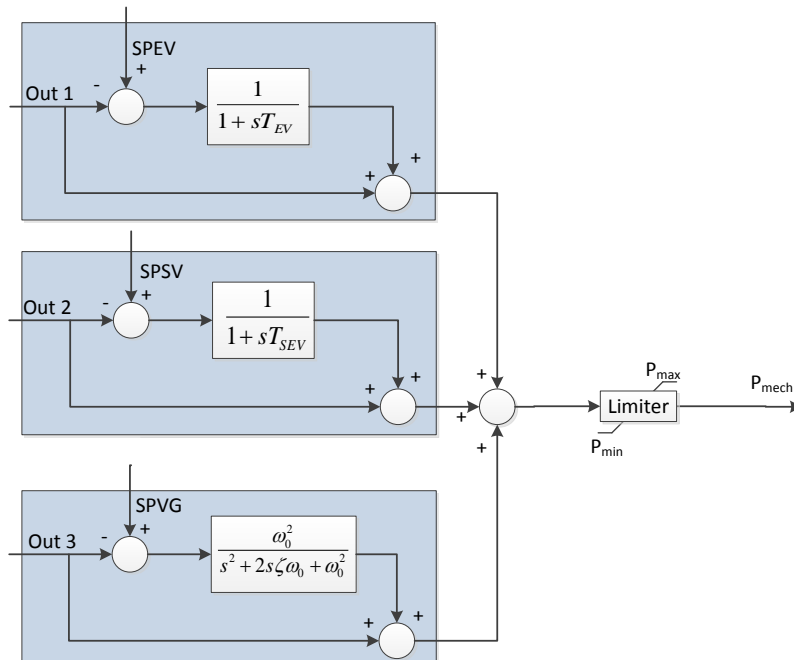

Figure 55: Gas Turbine dynamics

where, ω_0 is the un-damped natural frequency and ζ is the damping ratio. From Figure 55, T_{EV} is the time constant for environmental burner and T_{SEV} is the time constant for sequential environmental burner. The mechanical power of the gas turbine (P_{mech}) is a function of CFM, CEV, CSEV, CVGV and CLC and is limited between P_{max} and P_{min} .

5.3.2 Model performance

The following will illustrate the performance of the developed DCHP model through set of simulations. The simulations illustrate the unit influence on system dynamic behaviour. The possible malfunctions noticeable in isolated system will be smoothed by large power system inertia, as the DCHP unit is only a small part of the whole power system. The network layout for the simulations of the DCHP power plant is shown in Figure 5-23

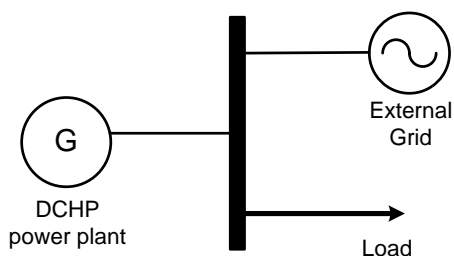

Figure 56: Network layout for evaluating DCHP response

The model performance is evaluated, like the CHP power plant. The network layout includes a DCHP power plant, load and a thevenin equivalent model of an external grid. The DCHP power plant has the capacity of 220 MW, i.e. capacity of an aggregated CHP power plant in Eastern Danish power system used in this study. The load of 220 MW is initially considered for balanced power system operation and the external grid has a frequency response of 6000 MW/Hz and inertia of 16 seconds. The dynamic performance of power plant model is evaluated with steps in reference power. Also, a load step illustrates the primary response of a DCHP when frequency deviates from its nominal level.

a) Steps in reference power

Figure 57 shows the DCHP response for negative and positive step in the active power reference set point. The reference power is stepped in 0.1 pu (22 MW) for every 10 minutes, from 1 pu to 0.5 pu and the stepped back to 1 pu. The DCHP response mainly depends on the ramp rate limitation associated with the gas turbine.

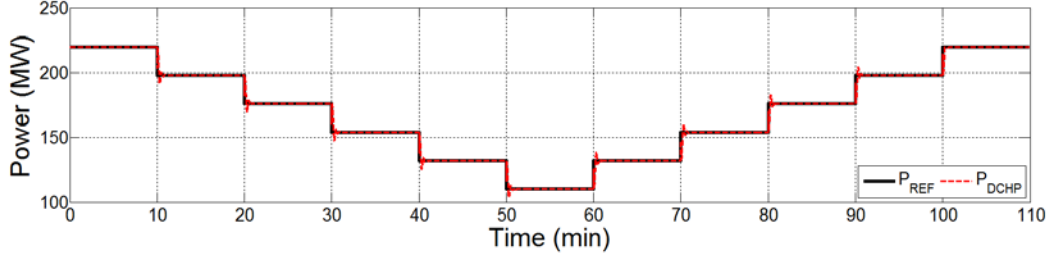

Figure 57: Step response of a DCHP power plant

b) Primary response from DCHP

The speed governor of the DCHP provides the primary response in case of power imbalance seen as frequency deviance from its nominal level. The primary response of the power plant depends on the droop characteristic of the governor, which is considered 4% in this study. Figure 58 shows the frequency and governor response for a load step of 22 MW (0.1 pu). The load step is applied at $t = 0$ seconds when DCHP is operating at 0.8 pu. From theoretical studies, the steady state change in frequency for load step of 0.1 depends on power system frequency characteristics, i.e.:

$$\beta_{PS} = \beta_{grid} + \beta_{DCHP} \quad (43)$$

$$\text{where, } \beta_{DCHP} = \frac{P_{DCHP}}{R \times f} = \frac{220}{0.04 \times 50} = 110 \text{ MW/Hz} \quad (44)$$

$$\rightarrow \beta_{PS} = 6000 + 110 = 6110 \text{ MW/Hz} \quad (45)$$

The steady state frequency of the power system is then calculated as:

$$\Delta f_{ss} = - \frac{\Delta P_{load}}{\beta_{PS}} = - \frac{22}{6110} = - 0.0036 \text{ Hz} \gg f_{ss} = 49.996 \quad (46)$$

The DCHP power plant will detect the change in frequency as change in generator speed and will responds to it by releasing the primary reserves. The primary response from the DCHP and the deviation seen on the external grid will be:

$$\Delta P_{DCHP} = -\Delta f \times \beta_{DCHP} = 0.396 \text{ MW} \approx 0.4 \text{ MW} \quad (47)$$

$$\Delta P_{exchnage} = -\Delta f \times \beta_{grid} = 21.6 \text{ MW} \quad (48)$$

Figure 58 to Figure 60 plots the dynamic response of a power system for a load step, where Figure 58 shows the change in system frequency, Figure 59 shows the governor and DCHP response and Figure 60 shows the power deviation on the external grid due to the residual power imbalance after primary response from the DCHP power plant.

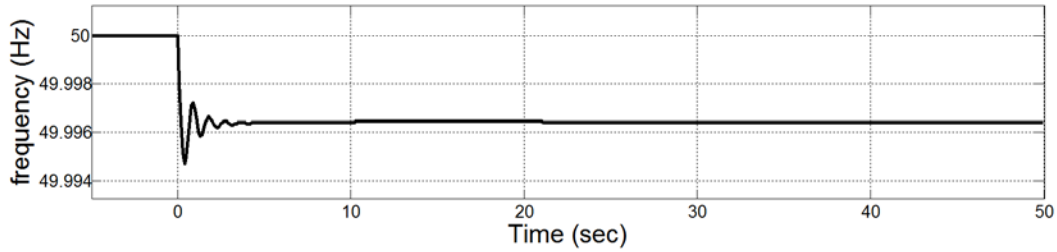

Figure 58: Frequency response to a load step

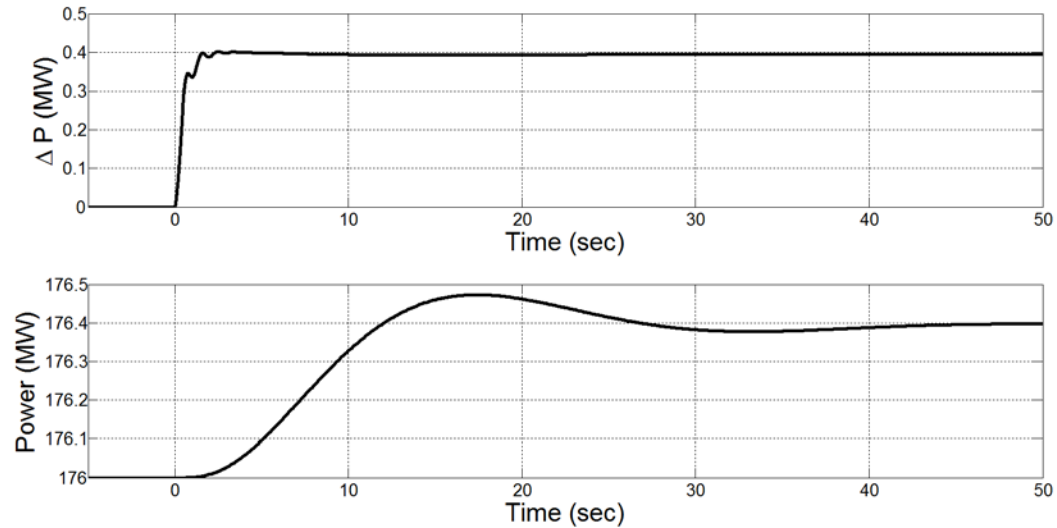

Figure 59: Response to a load step; top: governor response, bottom: DCHP output

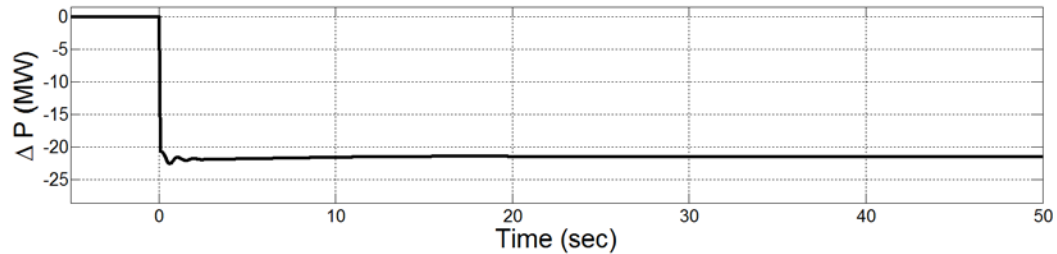

Figure 60: Power deviation on External grid due to load step

The above figures show that the governor activates the FCR in response to the frequency change due to the load step. The reserves deployment mainly depends on the droop settings of the DCHP governor. The governor provides the quick response but the DCHP react in approximately 30 – 40 seconds due to the delays and ramp rates associated with the turbine unit.

5.4 Wind Power Plants (WPPs)

Power balancing control is one of the most important issues that need to be addressed for future Danish power system. A WPP model is needed to investigate the dynamic behaviour of wind power generation that can contribute in power balancing operation. The model shall take the

inherent characteristics of the wind power at the power system level, rather than making accurate predictions of the impact of a specific wind farm.

At power system level, aggregate performance of a large number of wind turbines is more important than the details of an individual wind turbine. In this section, a simplified aggregated WPP model is developed for long term dynamic simulation studies. The model has as starting point suggested in the IEC61400-27-1 committee draft for electrical simulation models for wind power generation. However, the model is simplified for the active power control purpose which is in focus in the present study but yet includes the relevant dynamics for long term simulation studies.

Figure 61 gives an overview on the signals between the WPP level and the WT level. The WPP level interacts with the WT control level through set of signals, i.e. power set points and feedback signals, in order to provide relevant grid support. The WPP controller decides the power set points for each individual wind turbine controller, based on the available wind power, delta set points from AGC, and measurements in PCC and the feedback status signals from the wind turbines. The power set points to the WTs controls the overall power production from the WPP.

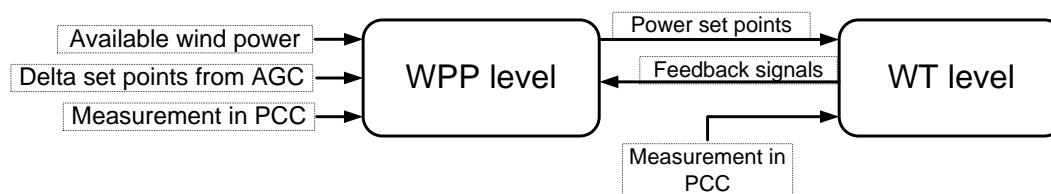

Figure 61: Overview of the signals on WPP and WT level

In this study, WPP actively participate in the active power balance control of the power system. The control of WPP is integrated into the AGC system to compensate the power imbalances between demand and generation in real-time. The WPP model is an aggregation of onshore and offshore wind farms in their respective power systems.

5.4.1 Modelling WPP

An aggregated WPP model is developed to examine the dynamic response of a WPP during power imbalances, in long term dynamic simulation studies. The model reduces the computational effort but still maintain the capability to predict unit influence on system dynamic behaviour. The model accounts for dynamic features of interest for the targeted ancillary services, i.e. primary and secondary control from WPP.

An aggregated model of WPP, illustrated in Figure 62, is developed for long term dynamic simulation studies based on studies in [69]. The simulation model contains the primary and secondary control capabilities and the dynamics relevant for the present investigation.

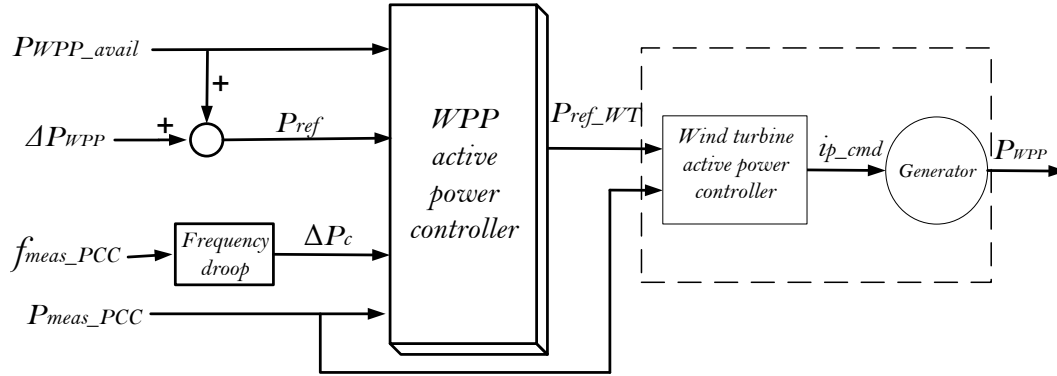

Figure 62: Aggregated WPP model

As illustrated in Figure 62, the aggregated wind turbine model includes an active power controller and a generator system. The generator system simulates the wind turbine response from the grid side. The wind turbine model provides the relevant dynamic response with respect to active power control capabilities, using as inputs the measured power at point of common coupling (PCC) and the reference power (P_{ref_WT}) from the WPP active power controller. The P_{ref_WT} to the wind turbine model is calculated inside the WPP active power controller based on two input signals. One input signal is conducted based on the primary response from the WPP (ΔP_c), while the other (P_{ref}) is determined based on the required secondary response (ΔP_{WPP}) from the AGC and the available wind power signal (P_{WPP_avail}) from the power balancing model. Besides the two mentioned inputs signals, the WPP active power controller is also using information on the measured power at PCC (P_{meas_PCC}), in the decision of the P_{ref_WPP} .

I. Wind turbine generator

The wind turbine generator model is based on type IV technology, as it offers a great deal of operational flexibility. The full scale converter of type IV wind turbine decouples the machine side from the grid. The machine side converter controls the generator by operating it at optimum rotor speed and the grid side converter independently controls the active and reactive power flow to the grid. As the dynamic behaviour of the wind turbine from the grid side is determined by the full scale converter, therefore the wind turbine generator is modelled as a static generator.

Static generator in a non-rotating generator and can typically support both a current source and a voltage source model. In present implementation, a current source model is used. Figure 63 and Figure 64 respectively shows the models for generator system and reference current generator. The active component of the reference current and the PLL decides the dynamic response of the static generator. The reference current model provides the ramp rate limitation and also limits the reference value based on available wind power. Notice that the current source model is considered ideal, therefore the current controller is not included.

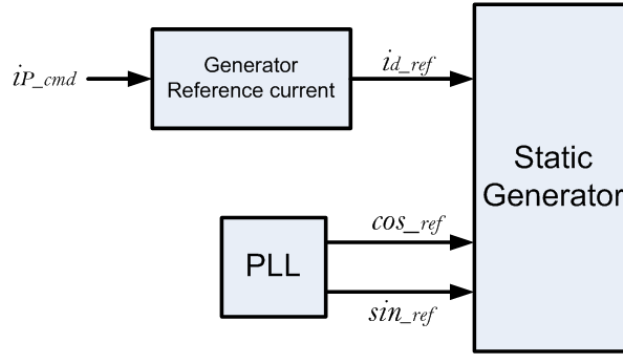

Figure 63: Generator system model

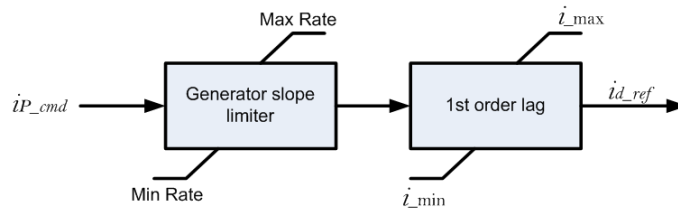

Figure 64: Generator reference current model

II. Wind turbine active power controller

Wind turbine active power controller models the dynamics involved in active power control at the wind turbine level. The active power controller controls the active power output from the wind turbine, i.e. the wind turbine generator. The active component of the current (i_{p_cmd}) for the generator is decided based on the reference power from WPP active power controller (P_{ref_WT}) and the measured power at PCC (P_{meas_PCC}). The PI controller decides the i_{p_cmd} , using the error signal between the P_{meas_PCC} and the P_{ref_WT} as input. The active power control loop of the wind turbine controller is illustrated in Figure 65.

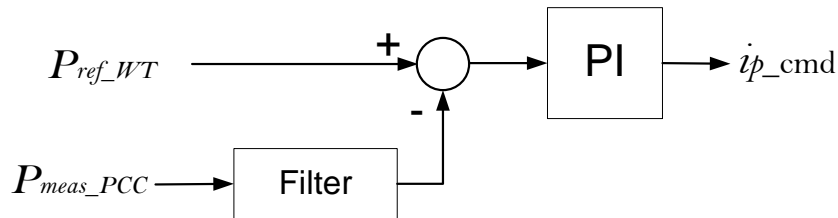

Figure 65: Wind turbine active power controller

III. WPP Active power controller

An active power control loop on WPP level is shown in Figure 66. The WPP controller develops the P_{ref_WT} in response to change in P_{ref_WPP} . The WPP controller defines the P_{ref_WPP} as a function of P_{ref} , ΔP_c , and P_{meas_PCC} . The PI controller decides the P_{ref_WT} for the aggregated WT model, using the error signal between the P_{meas_PCC} and the P_{ref_WPP} as input. The P_{WPP_avail} is used to limit the output of the PI controller.

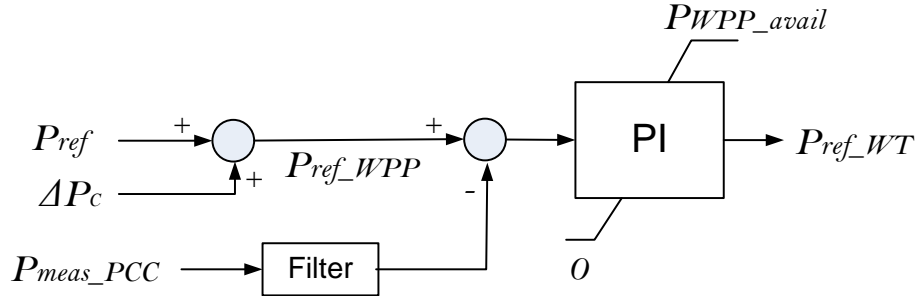

Figure 66: WPP active power controller

IV. Frequency droop – Primary response

The frequency droop provides the primary frequency control from aggregated WPP model. The frequency droop block in Figure 67 consists of a dead band and a droop. Dead band avoids excessive change in the reference power for any small frequency deviations. A control signal is generated if frequency deviation is higher than the predefined values of the dead band. The input to the frequency droop is measured frequency at PCC while output is the ΔP_c . The ΔP_c depends on droop characteristics, available wind power and frequency deviation from its reference value. If WPP is generating the available power, no primary response will be offered during negative power imbalances.

5.4.2 Model performance – Aggregated WPP

The dynamic features of an aggregated WPP model is assessed through set of simulation regarding active power balance control. The simulation network layout used for assessing the WPP performance is shown in Figure 67.

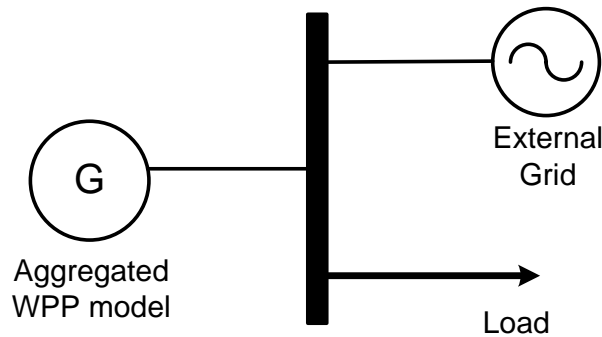

Figure 67: Network layout for evaluating WPP performance

The network layout includes an aggregated WPP power plant, load and thevenin equivalent model of an external grid. The performance of the aggregated WPP model is tested like CHP power plant. The WPP power plant has the capacity of 2280 MW, i.e. wind power capacity in the Eastern Danish power system in this study. The steps in reference power and the load steps assess the dynamic performance of the WPP plant model in long term dynamic simulations.

a. Steps in reference power

Figure 68 shows the response of WPP for the negative and positive step in the active power reference set point. Steps in the reference power of 0.1 pu (228 MW) are performed for every 10 seconds. The reference power is first stepped down from 1 pu to 0.5 pu and then stepped back to 1 pu. The WPP responds in less than 3 seconds for the step in reference power, as Figure 69 shows the WPP response for the step in reference power from 0.8 pu to 0.9 pu.

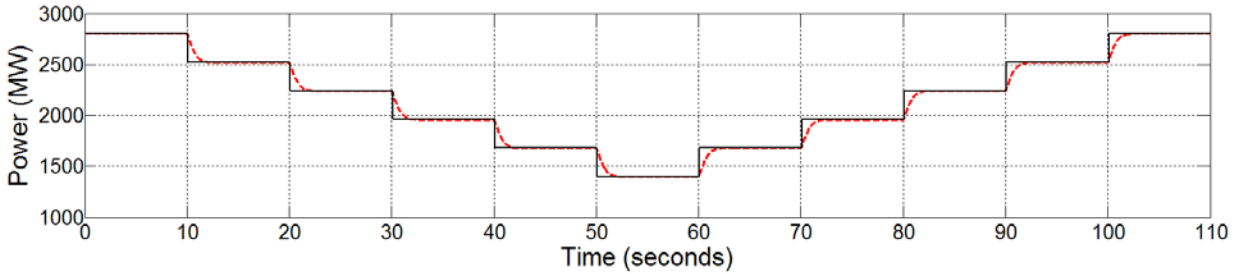

Figure 68: Steps in reference power for WPP

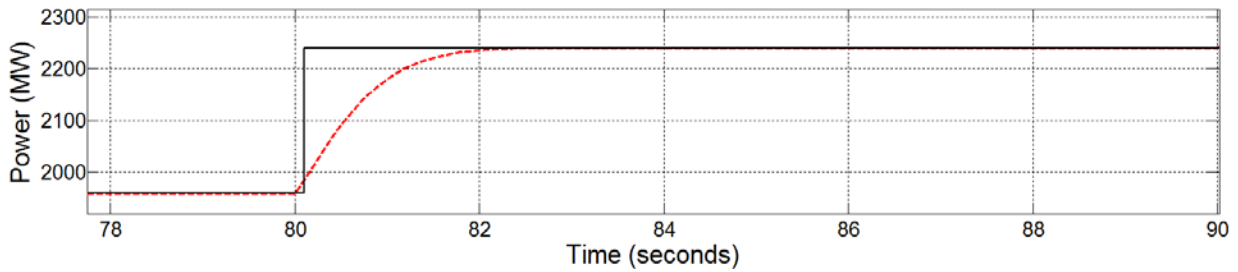

Figure 69: WPP response for a step in reference power

a. Active power control capabilities

The WPP capability to actively participate in ancillary services is assessed through a load step, when WPP is generating 0.8 pu of the available wind power. The frequency droop block provides the primary response for the load step of 114 MW, while AGC changes the reference power in order to restore system frequency and primary reserves. The primary response from power plant depends on the droop setting (0.04 in this study). A step in load deviate the system frequency from its nominal level and the deviation depends on the power frequency characteristics of the power system, i.e.:

$$\beta_{PS} = \beta_{grid} + \beta_{WPP} \quad (49)$$

$$\text{where, } \beta_{WPP} = \frac{P_{WPP}}{R \times f} = \frac{2800}{0.04 \times 50} = 1140 \text{ MW/Hz} \quad (50)$$

$$\rightarrow \beta_{PS} = \beta_{grid} + \beta_{WPP} = 6000 + 1140 = 7140 \text{ MW/Hz} \quad (51)$$

The steady state change in system frequency is then calculated as:

$$\Delta f_{ss} = -\frac{\Delta P_{load}}{\beta_{grid}} = -\frac{114}{7140} = -0.01596 \text{ Hz} \gg f_{ss} = 49.984 \text{ Hz} \quad (52)$$

The WPP will respond to this frequency change by releasing the primary reserves. The primary response from the WPP and the deviation on the external grid will be

$$\Delta P_{WPP} = -\Delta f \times \beta_{WPP} = 18.2 \text{ MW} \quad (53)$$

$$\Delta P_{grid} = -\Delta f \times \beta_{grid} = 95.8 \text{ MW} \quad (54)$$

The following figures, Figure 70 to Figure 72 shows the dynamic behaviour of system frequency, governor, WPP and the external grid for a load step.

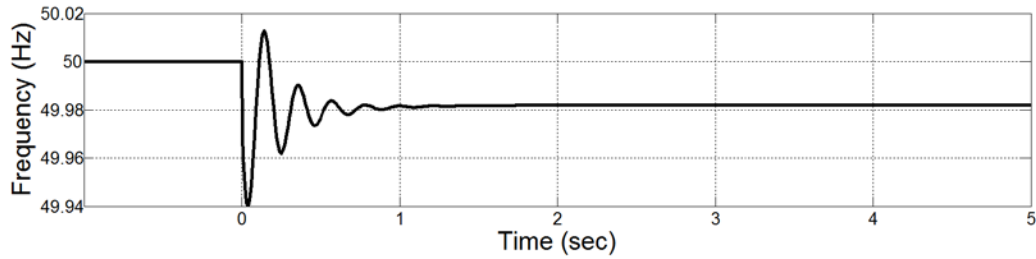

Figure 70: Frequency response to a load step

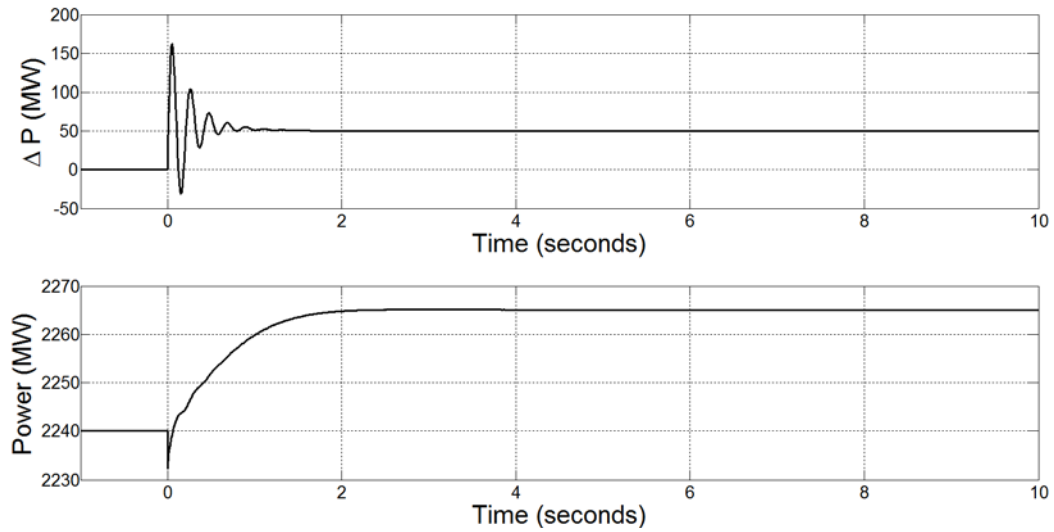

Figure 71: Response for a load step; top: governor response, bottom: WPP output

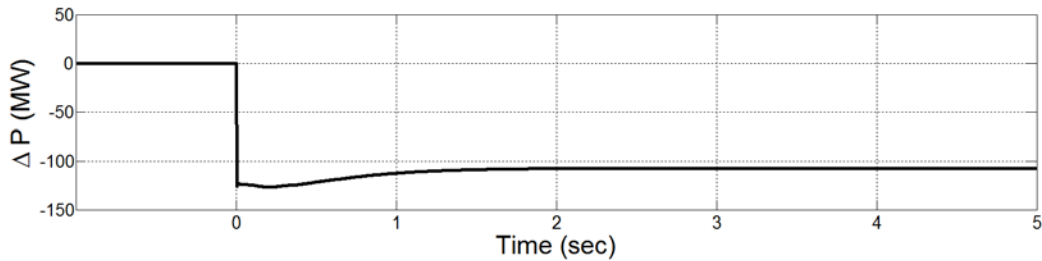

Figure 72: Power deviation on External grid

The primary response from WPP starts instantly with a load step and the entire reserves are activated in few seconds. The primary reserves are restored and the deviation on the external grid is removed by the secondary response from the WPP, with the inclusion of WPP control into the AGC. However, the response is prolonged to 8-10 minutes due to the delays in the AGC system, as shown in Figure 73 to Figure 75.

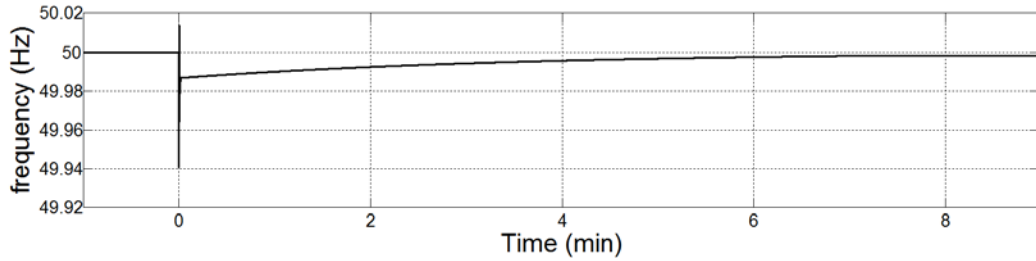

Figure 73: Secondary frequency response

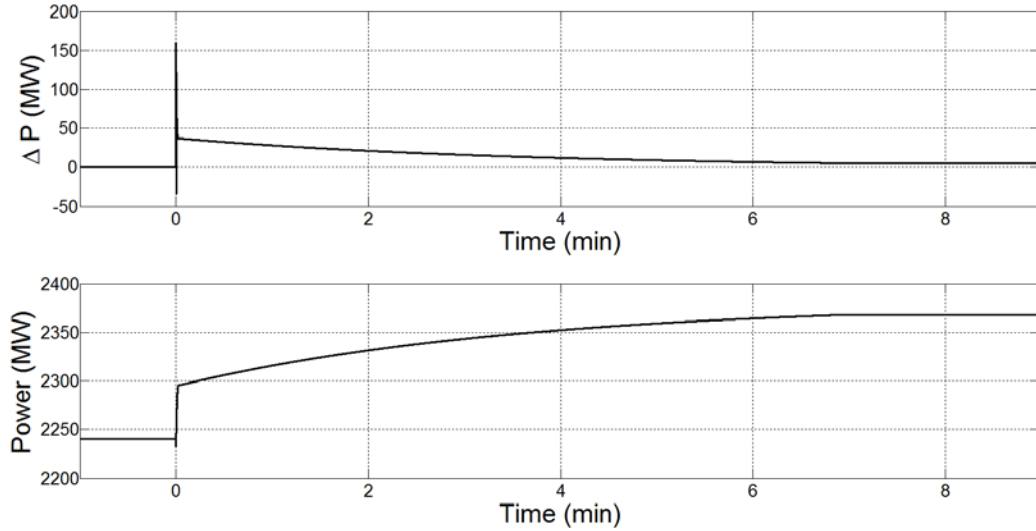

Figure 74: Secondary response; top: Primary reserves, bottom: WPP output

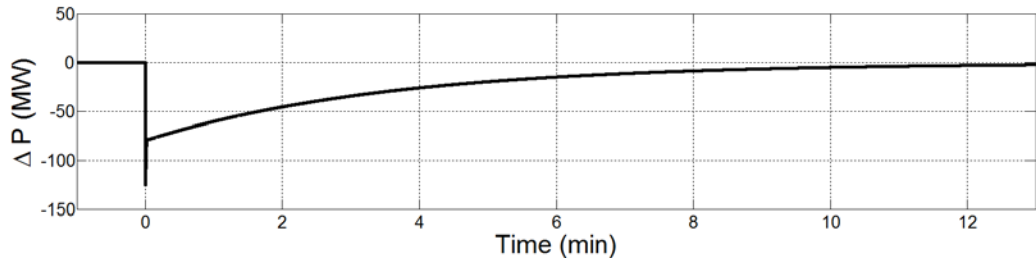

Figure 75: Power deviations on External grid after secondary response

The above simulations show that the WPP can contribute in primary and secondary control.

5.5 Summary

In this chapter, aggregated models of the power generating units and the system interconnections for the future Danish power system are presented. The aggregated models are developed for intended application, i.e. active power balance control in a power system and contain all subsystems and time constant that are of importance in the long-term dynamic simulation studies. The aggregated models reduce the modelling effort and eliminate the necessity to specify unnecessary data for each generating unit in the system while keeping the dynamic features relevant for every specific application.

An aggregated CHP model is implemented and developed for active power control purpose. This model estimates the dynamic features of CHP during active power imbalances in long term dynamic simulation studies, rather than making accurate predictions of the impact of a specific unit with a given technology. The response time and ramp rates associated with CHP, which are in order of minutes, are the dominant characteristic for power system studies. The aggregated CHP model consists of a thermal boiler, a boiler turbine controller, a steam turbine and a speed governor. The model contains the primary and secondary control capabilities, as well as the boiler dynamics of the CHP, i.e. steam turbine.

An aggregated generic model for DCHP power plants is simplified and includes the dynamics relevant for the present investigation. The gas turbine model estimates the physical restriction on turbine response of an aggregated DCHP. It can be observed that the unit response is mainly determined by the ramp rate limiter within the gas turbine model. The DCHP model contains only primary control capabilities, where the response is provided by the speed governor through activating primary reserves.

An aggregated WPP model implemented and developed in this study for active power control purpose at the power system level. The developed WPP model is an aggregation of onshore and offshore wind farms and is capable of providing ancillary services, i.e. primary and secondary active power control in a long term dynamic simulation studies. The WPP control is integrated within the AGC system and can provide the fast secondary control. The power of WPP is calculated based on the power of one turbine multiplied with the number of turbines in the WPP.

This chapter also includes the Danish power system interconnection with Nordic and CE power system. The HVDC interconnections are modelled as negative load and are operated as their planned power exchange. The AC interconnections are modelled as a slack bus with the negative load model of the planned power exchange. The primary response from the interconnected power system can be seen as deviations on the slack bus or in other words on the AC link.

Chapter 6

System analysis with large scale integration of wind power

This chapter analyses the future status of the Danish power system with large scale integration of wind power. The studies investigate, through sets of simulations, the long term dynamic behaviour of the power system regarding active power balance control, utilising the developed models and control strategies described in Chapter 4 and Chapter 5. The chapter initially analyse the dynamic behaviour of the developed power system model through a load step, where the governor response activates FCR and AGC activates the FRR. The activation of FCR depends on the power frequency characteristics of the synchronous power system.

The main focus of this chapter is to analyse the real-time power balance control in an interconnected power system, where wrong forecasts of wind power leads to huge power imbalances. These studies are based on the assumptions for the year 2020 and the time series for generation, load and power exchange are provided by the hour-ahead power balancing model, SimBa. In the beginning, set of simulations analyses the power system behaviour when CHP provides the required secondary response. Then the impact of integrating WPP control into AGC system is analysed, where WPPs contributes to the positive and negative power imbalance while operating in delta mode, and also when WPPs generate the available power and only contributes to positive power imbalances. The secondary control power and the sustained power imbalances are then minimized with tertiary control, where a heuristic algorithm emulating the control room response activates the regulating reserves. This chapter also analyses the impact of integrating the consumption units (cold storage and electric vehicles) into AGC system, where secondary control is provided by WPP during generation excess and by load during generation deficit.

6.1 Dynamic analysis of power system model

Several dynamic models have been developed to study the active power balance control in a highly wind power integrated power system. The models are used to gain some insight into possible outcomes, which are later used to study the real-time balance control in modern power systems. However, before these models are used for analysis, there is a need to understand the

response of a model's outputs to the changes in the model's inputs. This section shortly investigates the dynamic response of the developed power system model through a load step.

For this process, Eastern Danish power system is considered with their intended future generation and power exchange capacities. The power system model includes aggregated models for WPP, CHP and DCHP, system interconnections, load and the AGC system. The dynamics on AC interconnection is studied through external grid, which emulates the specific characteristics of Nordic grid having inertia of 16 seconds and primary frequency response of 6000 MW/Hz. Table 5 provides the capacities and the initial operating points of the generating units, system load and system interconnection.

Table 5: Capacities and operating point of the generating units, system interconnections and system load

Power system model	Generating units			System interconnections			
	CHP (MW)	DCHP (MW)	WPP (MW)	Sweden (MW)	GBL (MW)	Germany (MW)	Load (MW)
Capacities	1754	220	2800	1700	600	600	-
Operating point	1578.6	198	2520	1319	600	600	1777.6

The following set of simulations analyse the performance of the power system model in a long term dynamic simulation studies through two study cases. First case shows the primary response from the generating units and the interconnected power system when a positive load step is applied. The response from the interconnected power system can be seen as deviation on AC link, i.e. external grid. The second case evaluates the AGC response with and without integration of wind power. The secondary control from the CHP is limited to ± 90 MW while WPP response depends on the availability of wind power.

6.1.1 Primary response

The generating units equipped with speed governors releases FCR for any change in system frequency from its nominal level. This automatic frequency response, following a power mismatch between generation and load, stabilizes the system frequency at a new level. The response depends on the power frequency characteristics (β) of the synchronous power system, as discussed in earlier chapters. In this study, the interconnected power system and the speed governors of CHPs, DCHPs and WPPs provides the required primary response. The response from the aggregating generating units depends on the operating conditions, e.g. if the WPP is generating the available power than its can respond only to the positive power imbalances. For this study, Table 6 shows the power frequency characteristics of the generating units in Danish power system and the interconnected power system.

Table 6: Droop settings and power frequency characteristics of generating unit and interconnected power system

	CHP	DCHP	WPP	Nordic grid
Droop (%)	4	4	4	-
Frequency response 'β' (MW/Hz)	877	110	1400	6000

The overall response for the power system is the sum of frequency response offered by all generating units in the synchronizing grid, i.e.:

$$\beta_{PS} = \beta_{WPP} + \beta_{CHP} + \beta_{DCHP} + \beta_{grid} = 8387 \text{ MW/Hz} \quad (55)$$

To evaluate the active power control capabilities of the developed power system model, a load step of 300 MW is applied. The step in load creates a power mismatch between generation and load, which is initially compensated by the automatic response from all generating units within the Eastern Danish power system and the interconnected power system (Nordic grid). This automated response stabilizes the system frequency at a new level, which differ by Δf_{ss} from its nominal level. The new steady state frequency 'f_{ss}' depends on the load step and the power frequency characteristics of the synchronous power system, as shown in (56). Figure 76 plots the dynamics response of the system frequency following a load step.

$$\Delta f_{ss} = - \frac{\Delta P_{load}}{\beta_{PS}} = - \frac{300}{8387} = - 0.035 \text{ Hz} \gg f_{ss} = 49.965 \text{ Hz} \quad (56)$$

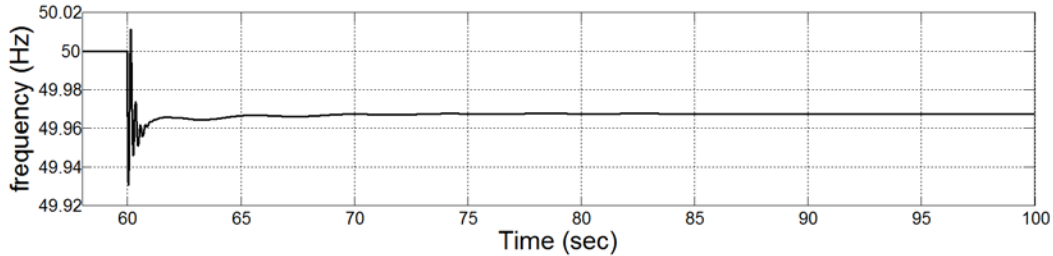

Figure 76: System frequency following a load step

The above figure shows that the system frequency stabilizes at a new level, almost similar to (57) calculation. The power plants with primary control capabilities respond to the power mismatch by releasing the FCR. The participation from the generating units and the synchronous grid depends on their power frequency characteristics and change in system frequency (Δf_{ss}), as shown in (57). Based on this equation, Table 7 calculates the primary control power offered by the generating units and the synchronous grid and Figure 77 and Figure 78 respectively shows their dynamic response.

$$\Delta P = -\Delta f \times \beta \quad (57)$$

Table 7: Primary response from the generating units and the synchronous grid

	P_{WPP} (MW)	P_{CHP} (MW)	P_{DCHP} (MW)	$\Delta P_{exchange}$ (MW)
FCR	50.2	31.4	4.2	214
Generation after primary response	2570.2	1610	202.2	-

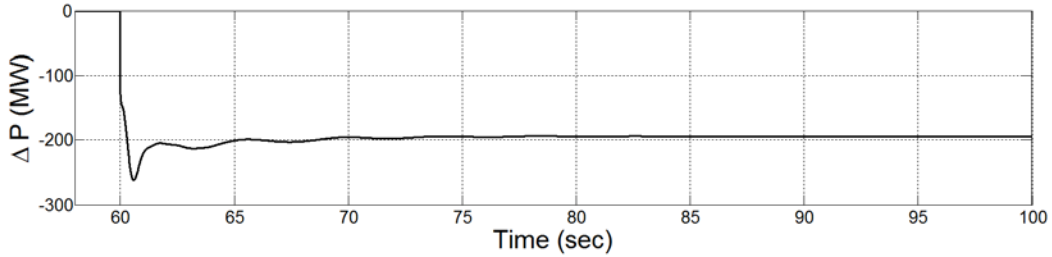

Figure 77: Response from synchronous grid seen as power deviation from its planned schedule

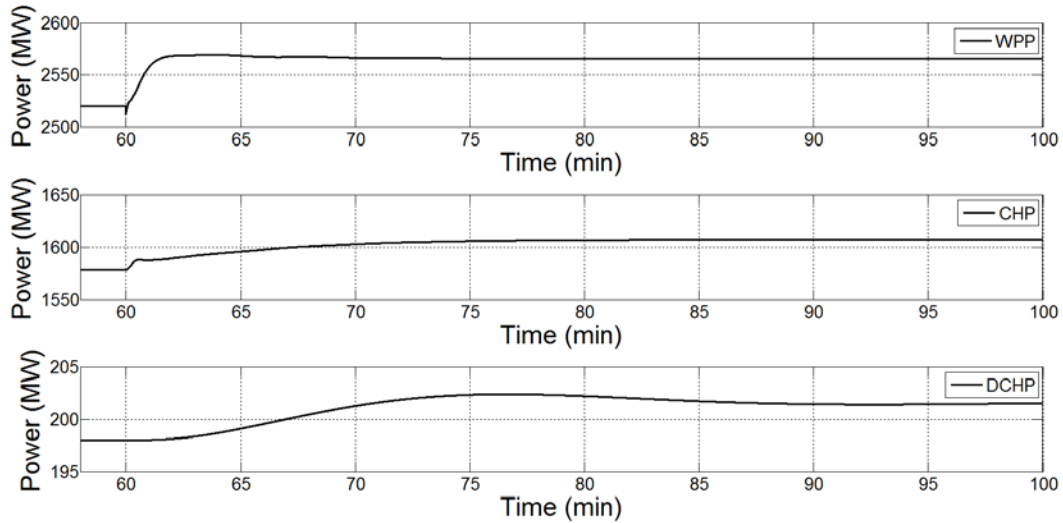

Figure 78: Primary response from generating units

It can be observed from above figures that the quick response from WPP is due to delays associated with active power controllers, while CHP response depends only on the delays associated with the steam turbine. The prolonged response from DCHP is due to the ramp rate limitations related to the gas turbine dynamics. It is worth mentioning that in this study the response from synchronous grid does not take ramp rate and response time associated with generating units in account, and therefore a load step results in a sharp response as shown in Figure 77.

6.1.2 AGC controlled secondary response

In order to restore the system frequency and the power deviation on the AC interconnection, AGC modifies the participating generating units' set points as a secondary response. This study

case first analyses the secondary response without integrating of WPP control into the AGC system and then with the integration of WPP control. In both cases the CHP response is limited to ± 90 MW.

As initially the WPP do not contribute in providing secondary control, therefore the secondary response is limited to 90 MW. This will result in a final power imbalance of 210 MW which is compensated through FCR. Table 8 provides the steady state generation from CHP, DCHP and WPP after the secondary response when the final deviation in system frequency is 0.025 Hz ($f = 49.975$ Hz).

Table 8: FCR, FRR and the final generation from WPP, CHP & DCHP after AGC response

	FCR (MW)	FRR (MW)	Generation after AGC response (MW)
WPP	35	-	2555
CHP	21.92	90	1690.52
DCHP	2.75	-	200.75
$\Delta P_{\text{exchange}}$	150	-	-

The system frequency, power exchange deviation and the output of the generating units are respectively shown in the Figure 79, Figure 80 and Figure 81. It can be seen from these figures that the AGC response from the CHP minimizes the frequency deviation and thereby replaces some of the primary reserves. It also minimizes the power deviation on the AC interconnection. The activation of FRR depends on the delays associated with AGC system and boiler model.

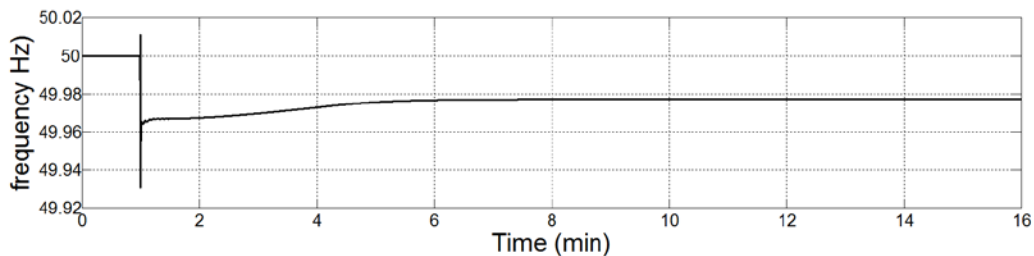

Figure 79: System frequency after AGC response

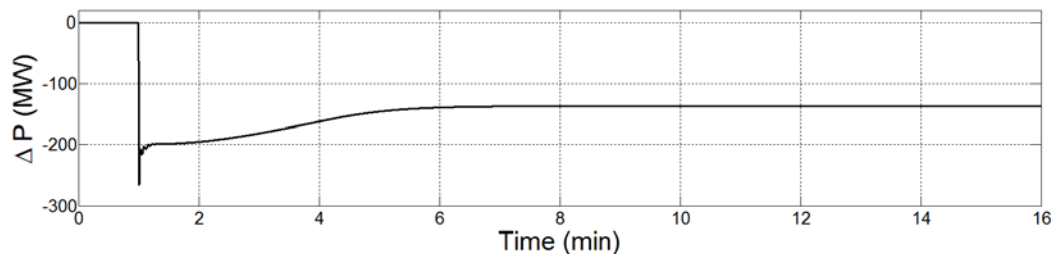

Figure 80: Deviation on external grid after AGC response

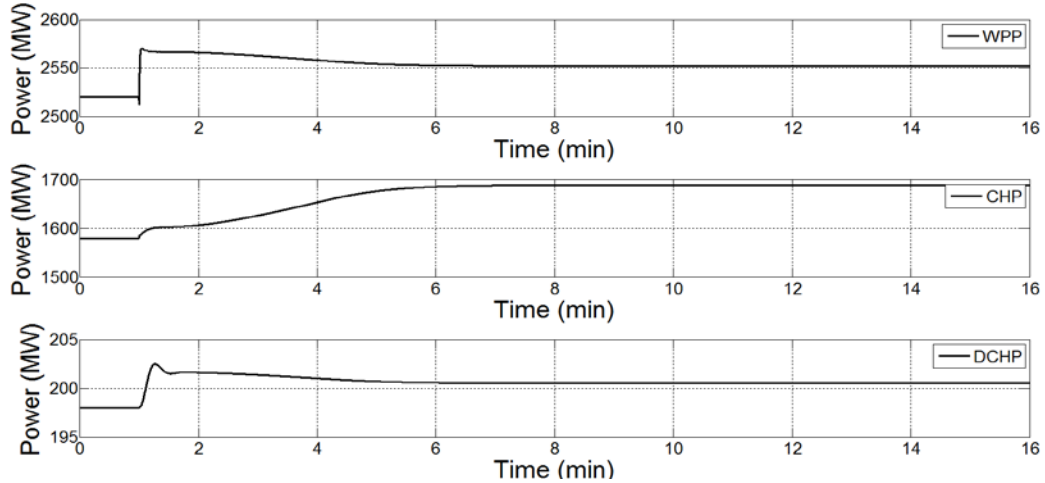

Figure 81: Output of the power plants after AGC response

The secondary control from CHP minimizes the power imbalance; however, more regulating reserves are required to restore the schedule power exchange, system frequency and the primary reserves. These secondary reserves can be provided by WPP, if operating in delta mode, as in this case study. For this purpose the WPP control is integrated into the AGC system. The dispatch strategy, illustrated in section 4.3, will first utilize the available wind power and then ramps the production from CHP. The P_{ACE} following a load step and the secondary dispatch is shown in Figure 82. The secondary response from WPP and CHP minimizes the P_{ACE} to zero. It can also be seen from this figure that the CHP dispatch (ΔP_{CHP}) is ramped only when WPP dispatch (ΔP_{WPP}) starts generating the available wind power. This AGC response will restore the system frequency to its nominal level and the power deviation on external grid to zero, as shown in Figure 83 and Figure 84. The overall secondary response is delayed due to delays associated with AGC system and the delays in the generating units due to their ramp rates and the response time.

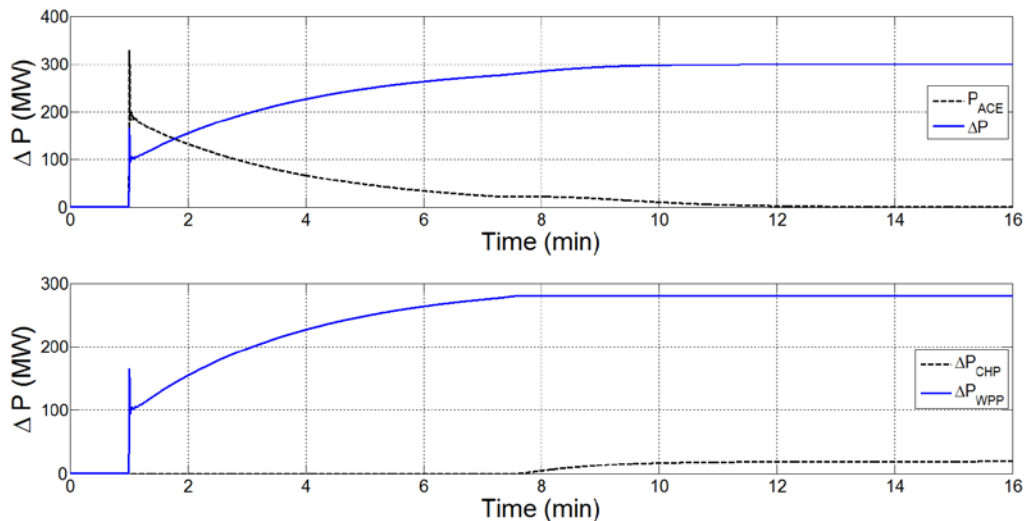

Figure 82: P_{ACE} and secondary dispatch for CHP and WPP

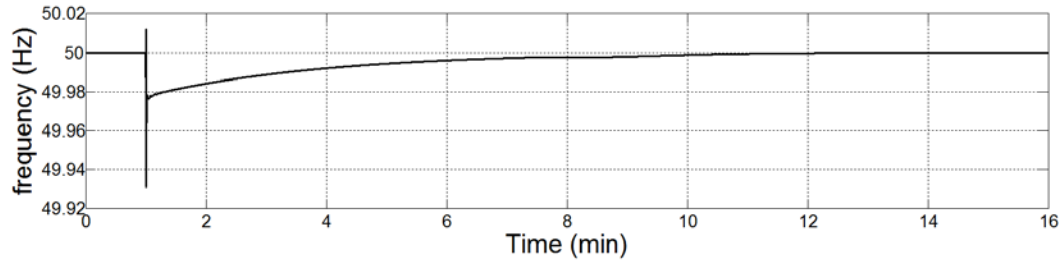

Figure 83: Frequency response with WPP integrated AGC

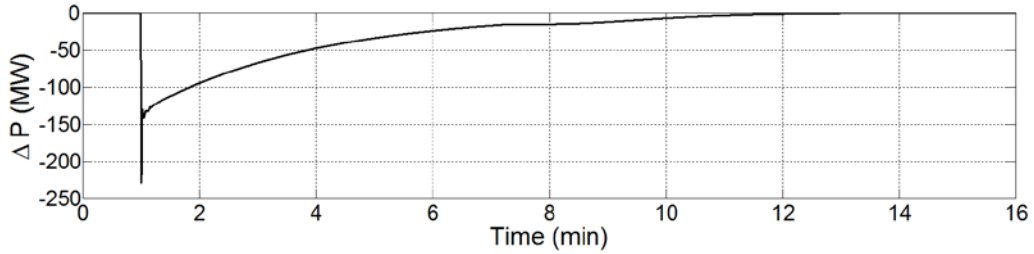

Figure 84: Power deviation with WPP integrated AGC

Figure 85 shows the output from generating units. The DCHP response, as it only participates in primary control, shows that the FCR are restored as the frequency reaches to its nominal level. The WPP is initially providing the secondary response and therefore the CHP output decrease, meaning FCR are restored. However, as the WPP starts generating the available wind power, the AGC ramps the CHP unit to mitigate the residual power imbalance.

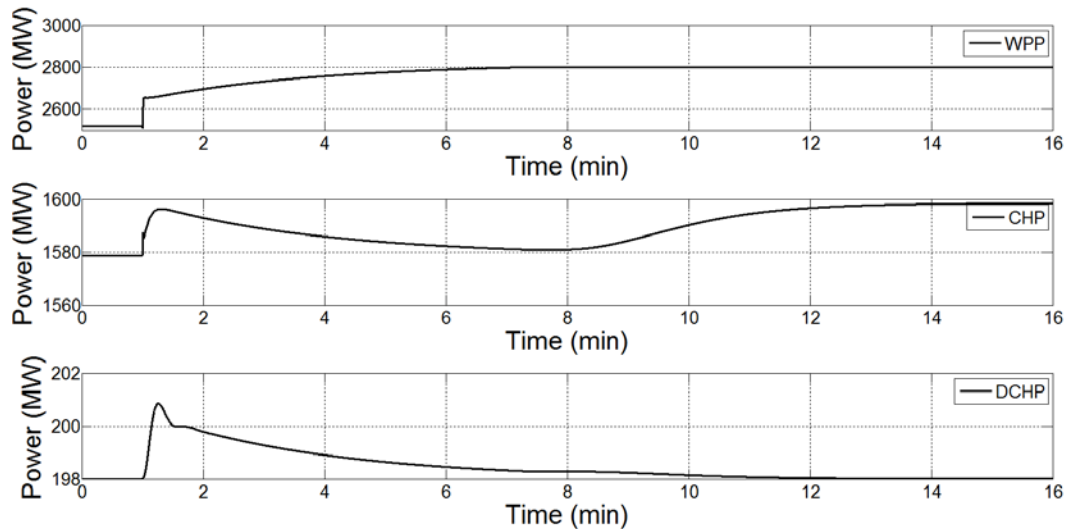

Figure 85: Generating unit output after the AGC response

This section analyses the dynamic response from the generating units and the AGC, for a load step. The results shows that the overall primary response is provided in less than 30 seconds and the amount of FCR offered depends on the power frequency characteristics of generating units and interconnected power system. The FCR and the system frequency are restored with the

secondary response (AGC), where main factors influencing the balancing operation are the delays associated with the AGC system and the generating units.

6.2 Impacts of wind uncertainty on power system operation

The foremost task of any system operator is to maintain a reliable and secure operation while transmitting the generated electricity to the end consumers. The balance between the generation and load has to be maintained at all time. The wind speed forecast plays an important role especially in a highly wind power integrated power system, as an incorrect wind speed forecast will deviate the generation and power exchange from its cost effective calculated schedule. The wrong forecast can also lead to balancing and control problems, and can introduce several challenges in maintaining a reliable and secure power system operation.

Conventional market models are simulating optimal UC and dispatch of power plants with one hour resolution [38]. However, the increasing large scale integration of wind power demands a regulating power plan with reduced planning horizon in order to manage the power imbalance efficiently during operational hour. SimBa is the kind of power balancing program that dispatches the generating units and power exchange in a five minute resolution. It takes the hour-ahead forecast of wind power, estimates the wind power fluctuation within each operating hour and simulates the wind power within the operating hour. Based on the simulated hour-ahead wind power forecast and the day-ahead power production plan from the spot market, SimBa releases an hour-ahead regulating power plan for schedule generation and power exchanges.

This and the coming case studies utilize the regulating power plan from SimBa for the analyses of power balance control in future Danish power system. The time series are generated for the scenario of the year 2020 based on the real data from 2009. The five minutes resolution plan reduces the regulating burden; however, the uncertain nature of wind may introduce several challenges to the power balance control of highly wind power integrated power system. No matter what, the TSOs have the responsibility to preserve a reliable power system operation and ensure a secure power supply, while keeping the generation at lowest possible cost.

Different studies are carried out in this case study to assess the performance of AGC. A set of simulations are performed using time series for generation, load and power exchange corresponding to one particular winter day when WPP are generating highly. It is assumed that, the power exchange is kept at its planned level, while CHP changes its power set point from planned schedule within the operating hour, as directed by AGC, to mitigate real-time power imbalances. The power generated within the operating hour from conventional and wind power plants, as well as the net exports with neighbouring power systems and the load demand in the Eastern and Western Danish power systems are shown in Figure 87 and Figure 88, respectively. The net exports are calculated by subtracting the total import power from total export power.

Wind Power Plant System Services

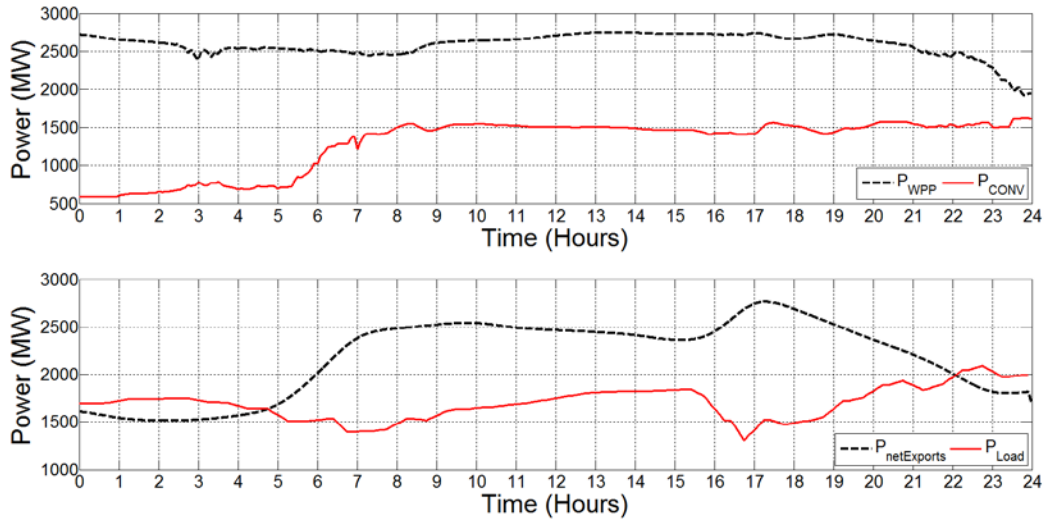

Figure 86: Eastern Denmark; Wind power, conventional power, net exports and load demand

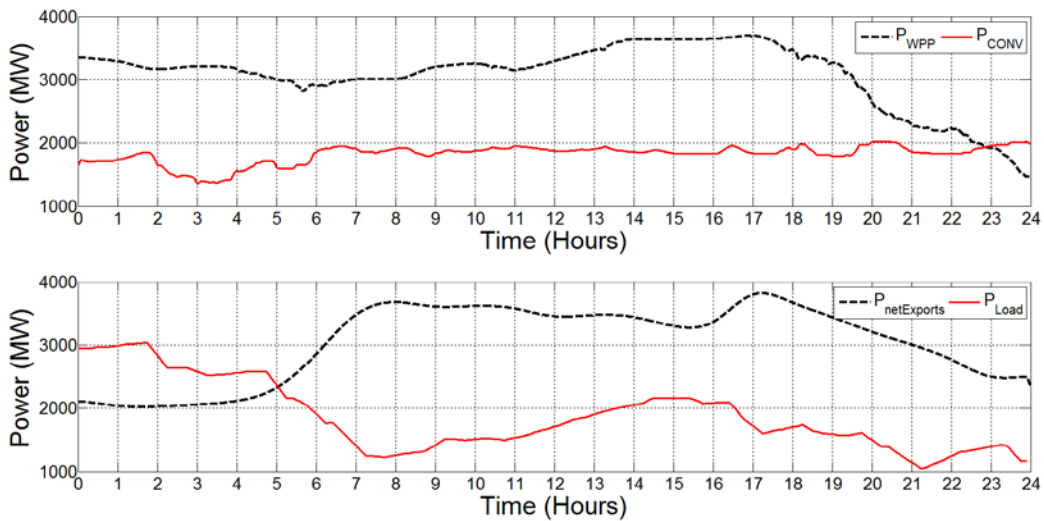

Figure 87: Western Denmark; Wind power, conventional power, net exports and load demand

Notice that, on the considered day, the availability of wind allows the WPPs to generate more power than conventional power plants. In Eastern Denmark, the conventional power plants generated 30.81 GWh of electricity, while WPPs generated 62.17 GWh, i.e. 66.85% of the total electricity production. The high production from WPPs allows the net exports of 40.533 GWh from Eastern Danish power system, when the load demand was 52.42 GWh. Alike in Western Denmark, 43.83 GWh is generated from conventional power plants and 73.97 GWh from WPP, i.e. 62.8%. While, the total load demand and the net exports are 73.075 GWh and 44.61 GWh, respectively. In terms of load demand, the wind power generated 118.6% of the total load demand in Eastern Denmark and 101.2% in Western Denmark. The generation from WPPs can meet the load demand in Eastern and Western Danish power systems, but the conventional power plants are operating to uphold the system reliability in case of unforeseen events. The

availability of wind power and the high load demand, in large scale wind power integrated power system, motivates to investigate the system behaviour on this particular day.

As aforementioned, the electricity markets are balanced taking in account the hour-ahead forecasts of wind and load. If the available wind power generated within the operating hour differs from the forecast, a power mismatch between generation and load will appear. Figure 88 shows the wind power deviation from its hour-ahead forecasted value in Eastern and Western Danish power systems, which is calculated as:

$$P_{error}^{WPP} = P_{available}^{WPP} - P_{hour\ ahead}^{WPP} \quad (58)$$

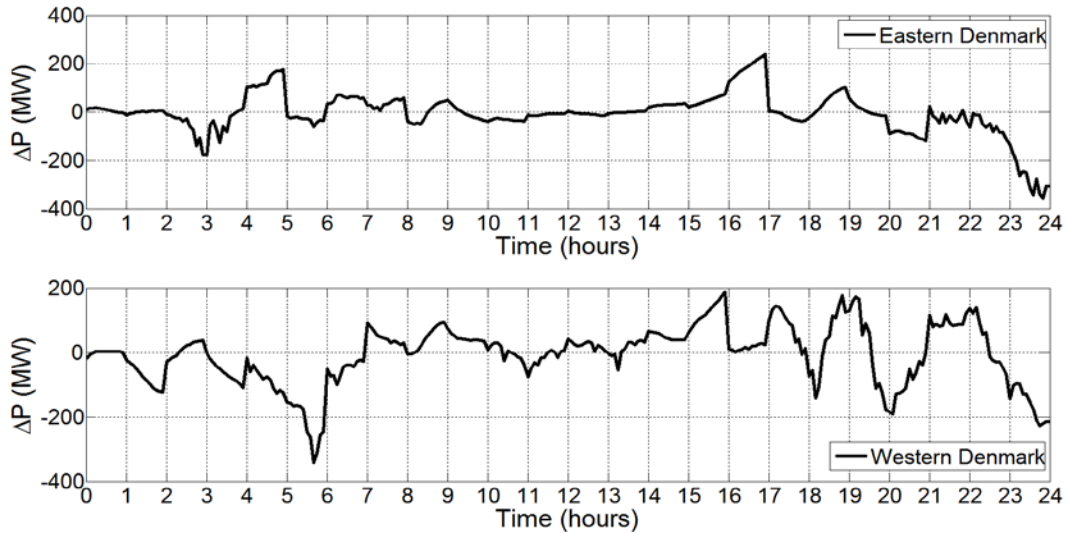

Figure 88: Hour-ahead wind power forecast error

The wind forecast error creates an imbalance between generation and load, which yields to a change in the system frequency. The speed governors respond to the change in frequency from its nominal level. The response, as aforementioned, depends on the power frequency characteristics of the generating units. The speed governor response for the generating units in the Eastern and Western Danish power systems is shown in Figure 89. However, the activation of FCR depends on the operating condition of the generation unit, e.g. in this case study the WPP is generating the available power and therefore it only responds to governor demand in case of generation excess. The response from interconnected power system will appear as deviation in power exchange from its hour-ahead schedule

After primary response, the AGC activates the FRR to return the system frequency and power exchange to their nominal level and also to restore the activated FCR. The AGC calculates the P_{ACE} , which is the measure of frequency deviance from its nominal level and also the deviation in power exchange from its schedule. The P_{ACE} replicates the total power imbalance in Danish power system if the frequency bias of AGC 'B' equals the power frequency characteristics 'β' of

generating units in the Danish power system. In this case study, the P_{ACE} is little exaggerated at times when some of the generating units are operating on their limits (maximum or minimum).

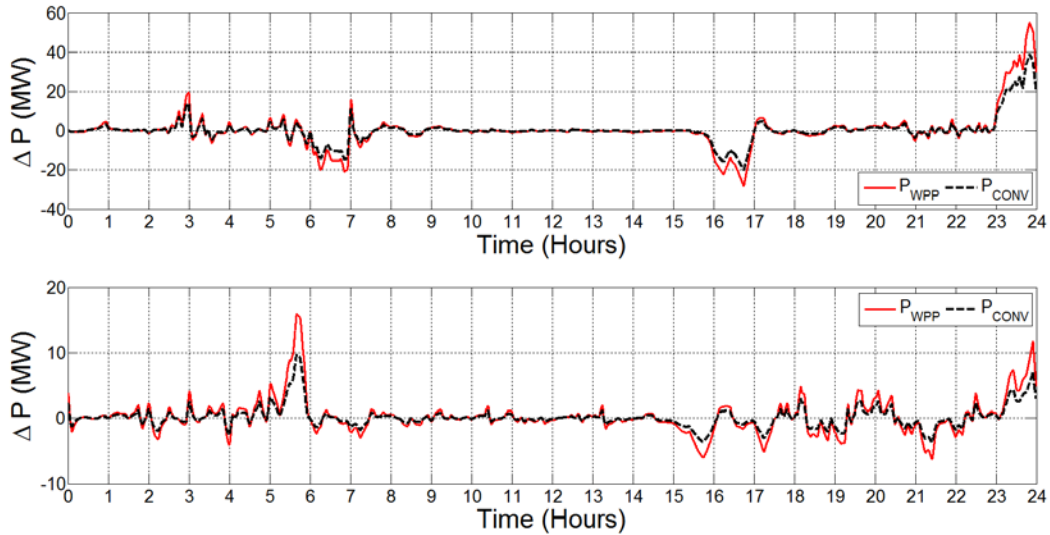

Figure 89: Speed governor response; top: East Denmark, bottom: West Denmark

Based on P_{ACE} , the AGC decides the required secondary response from participating generating units (CHP in this case study). The input and output of the AGC model, i.e. P_{ACE} and ΔP_{SET} , for the Eastern and Western Danish power systems are shown in Figure 90 and Figure 91, respectively. The ΔP_{SET} is limited to ± 90 MW, as the case of AGC acting on Western Denmark border with Germany. The AGC activates the FRR from CHP and reduces the P_{ACE} in Eastern and Western Danish power systems, depending on the available capacity.

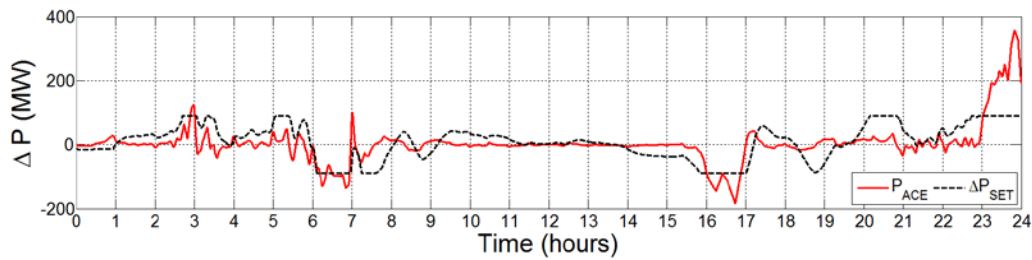

Figure 90: East Denmark; AGC response

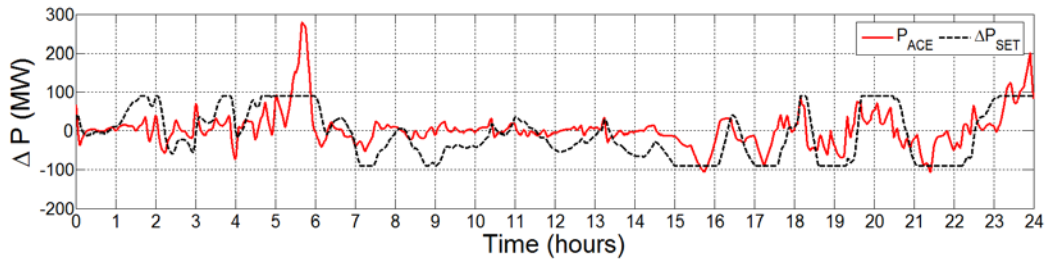

Figure 91: West Denmark; AGC response

The activation of FRR not only reduces the power imbalance, i.e. P_{ACE} , but also restores the FCR activated in this process. This process is illustrated in Figure 92, where speed governor and AGC responses for the Eastern Denmark are zoomed at specific hour. The speed governor activates the FCR for positive power imbalance (generation excess); however as the AGC senses the change in P_{ACE} , it responds by activating the FRR from CHP (ΔP_{SET}). The ΔP_{SET} increases until the P_{ACE} and the FCR are returned to zero level. In real power system operation, as in this study, the imbalances are changing continuously and the automatic reserves (FCR and FRR) continuously respond to minimize these imbalances and secure the power system operations. If the power imbalances are consistent then manual reserves are activated from the control room to relieve the FCR and FRR for future use. The activation of manual reserves is discussed in later case study.

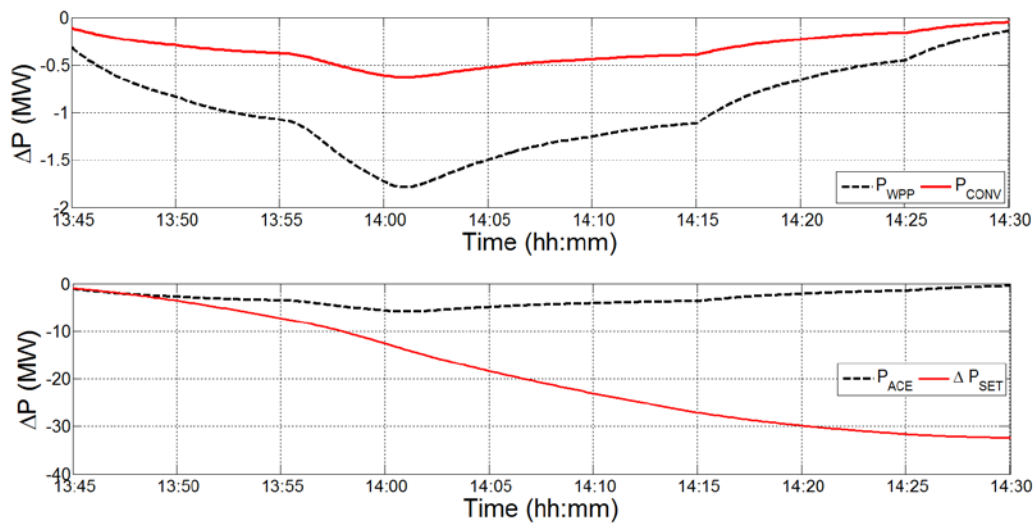

Figure 92: East Denmark; zoom view of primary and AGC response

Figure 93 shows the system frequencies in Eastern and Western Danish power systems after the AGC response, while Figure 94 compares the initial power imbalances with final power imbalances, which is seen as the power deviation from scheduled power exchange. As shown in above figures that the AGC responds to the power imbalances by providing new power set point to the generating units based on the P_{ACE} ; however, the frequency and power exchange in these power systems takes time to return to their nominal level. This is due to the delays associated with the AGC system and conventional power plants, which abstains them to change their output at the required rate i.e. P_{ACE} rate. These delays are caused due to the ramp in the reference power considered in this study (i.e. 30 MW/min) and also due to the slow boiler response of CHP units (i.e. the boiler needs 5 – 6 minutes to modify its output pressure when demanded). Moreover, the power imbalances are continuously changing and in return the AGC continuously adjust the CHP set point to reduce the real-time power imbalances.

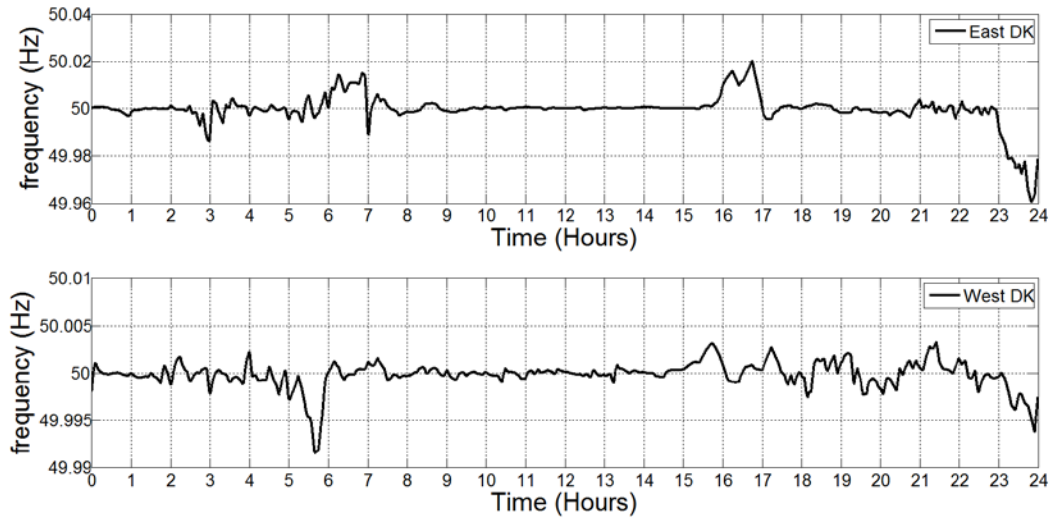

Figure 93: System frequency

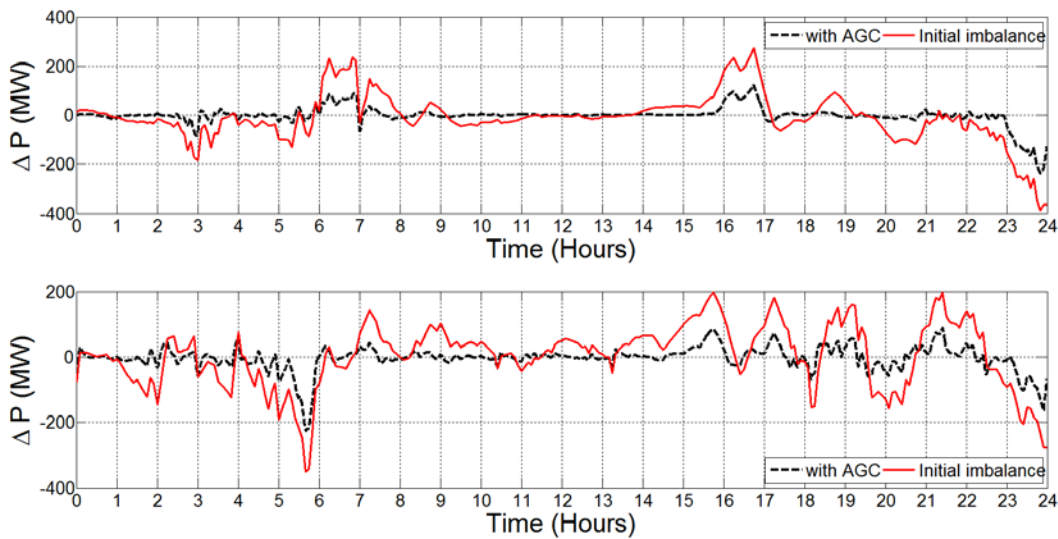

Figure 94: Initial and final power imbalances; top: Eastern Denmark, bottom: Western Denmark

The system frequency deviation illustrated in Figure 93 relates to the amount of power imbalance. The surplus power results in frequency rise, while the deficit in frequency drop. Notice that, in spite of a large power imbalance, as illustrated in Figure 94, the deviation in system frequency from its nominal level is insignificant. This is because the Danish power system is synchronously connected to stiff and large CE and Nordic power systems. The activation of FRR considerably reduces the real-time power imbalance (Figure 94); however, the active participation from WPP is required to further minimize the real-time power imbalances in a highly wind power integrated power system.

6.3 Integration of WPP control in AGC system

The active power balance control is getting more important for the TSOs over the years due to the dramatic increase of wind power penetration into the power systems. The power systems are evolving from classical systems operated and controlled by the conventional power plants into power systems based on wind power to a larger extent. This means, that the TSOs must be able to cope with new challenges and raising concerns about its dynamic security and reliability. Traditionally, conventional power plants have the task to maintain the active power balance and are capable of meeting the TSO guidelines. Their possible replacement in the future by WPPs of similar size increases the risk of system failures, unless the TSOs revise and set new requirements for WPPs, i.e. to participate in active power balance control.

This case study analyses the active power balance control when WPPs control is integrated in the AGC system. The proposed coordinated control strategy for the AGC between the CHP and WPP decides the real-time secondary dispatch to improve the active power balance in the power system with minimum secondary dispatch cost. The control strategy regulates the active power production from CHPs and WPPs, depending on operating reserves, dispatch limit and the generating cost. This case study will first analyse the WPP contribution in secondary control, where wind power are kept as reserves and also when WPP generates the available power. In former case, the WPP participate in up and down regulation process, while in later the WPPs can only provide down regulation services.

6.3.1 WPP operating in Delta mode

A set of simulations has been carried out to illustrate the dynamic performance of the proposed and implemented active power balanced control strategy, where wind power is directly integrated in the AGC control. The simulations are performed using the time series for generation, load and power exchange corresponding to one particular day of the year 2020 with high wind power. These time series are generated by SimBa; however, the available wind power is exaggerated for this case study. The time series from SimBa decides the reference power signal for WPP; whereas it is assumed that the available power is 1.03 times of the provided series. With this assumption, the AGC can utilise 3% of the reference power for regulation purposes.

The power generated within the operating hour by WPP and the available wind power in the Eastern and Western Danish power systems are shown in Figure 95 and Figure 96, respectively. These figures also show the load demand, conventional generation and the planned power exports with neighbouring power systems. The power exports with neighbouring power systems are calculated by subtracting the total import power from the total export power within their respective power systems.

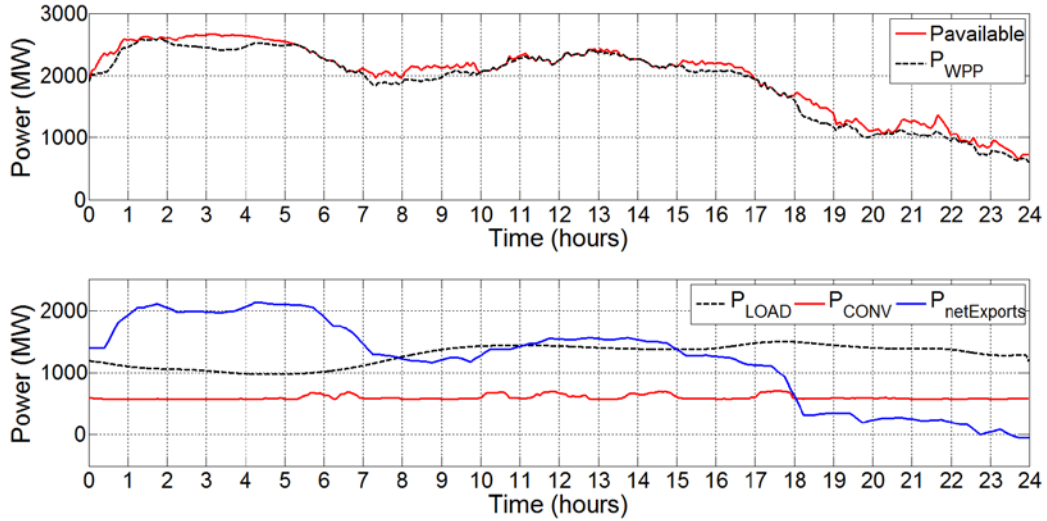

Figure 95: East Denmark; Wind power, conventional power, net exports and load demand

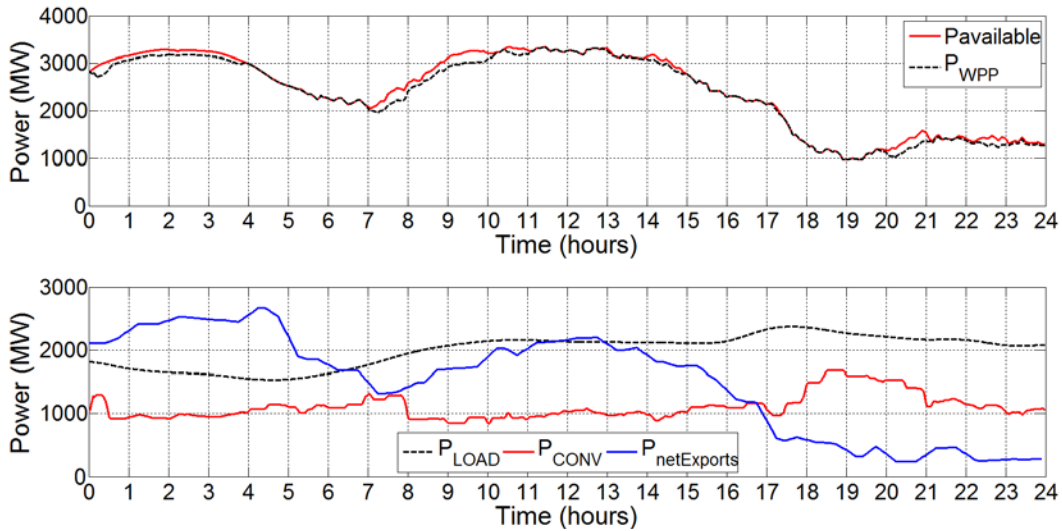

Figure 96: West Denmark; Wind power, conventional power, net exports and load demand

On the particular day under study, the availability of wind allows the WPPs to generate more power than conventional power plants, and hence positive net exports. In Eastern Denmark, the conventional power plants generated 14.38 GWh of electricity and WPPs generated 45.8 GWh, when the total load demand was 30.84 GWh. However in Western Denmark, 26.56 GWh is generated from conventional power plants and 57 GWh from WPP, and the total load demand was 47.92 GWh. The wind power generated 148.5% of the total demand in Eastern Denmark and 119% in Western Denmark and this high production allowed net exports of 29.38 GWh and 36 GWh, respectively.

SimBa provides the balanced hour-ahead time series for scheduled generation and power exchange. However, the real-time wind power, which in this study case decides the set point of aggregated WPP model, may differ from hour-ahead forecast. This aspect creates power

imbalance in Danish power systems. The real-time power imbalances in these power systems are shown in Figure 97. The speed governors of the aggregated generating units sense the power imbalances as a frequency change, and responds by activating FCR. The activation of FCR depends on power frequency characteristics of the generating units and the synchronous power system. The speed governor response in Eastern and Western Danish power systems are shown in Figure 98; however, the activation of FCR is dependent on the operating conditions of the generating units.

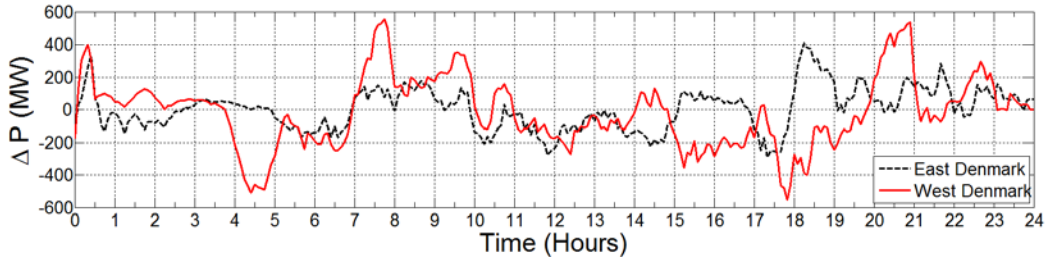

Figure 97: Real-time power imbalance

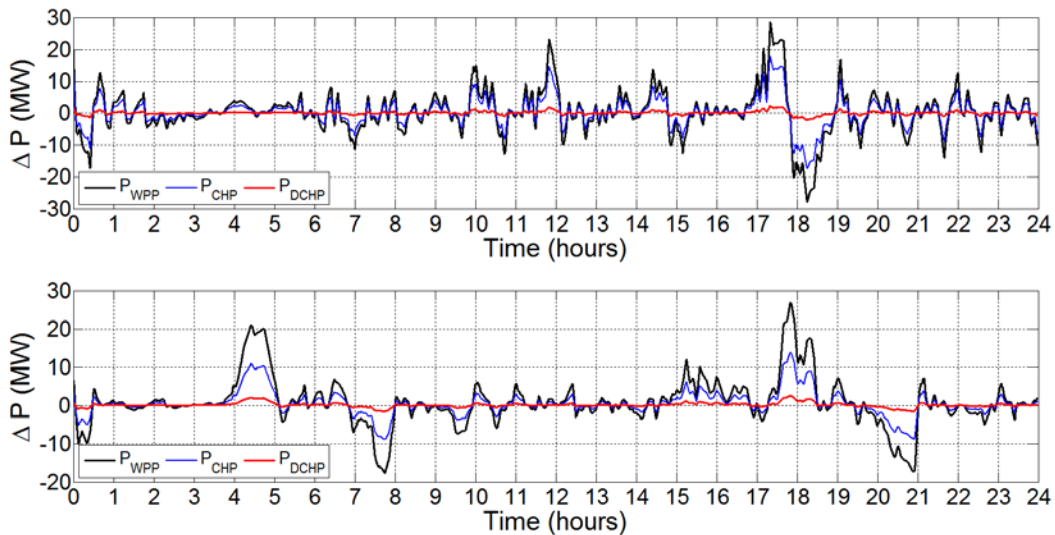

Figure 98: Speed governor response; top: Eastern Denmark, bottom: Western Denmark

As already discussed, that the wrong forecast of wind power alters the system frequency from its nominal level and the power exchange from its schedule. The activation of FRR in their respective power systems will return them to their nominal level. The FRRs are activated by AGC; however unlike previous case study, the WPP actively participates in the secondary dispatch process. The secondary dispatch process for this study, described in section 4.3, is based on cost minimization function, where WPP is regulated prior to CHP during positive dispatch process (generation deficit) and CHP is down regulated first during negative dispatch (generation excess).

AGC, as already discussed, calculates the P_{ACE} in their respective power systems and the secondary dispatch decides the change in set points for participating generating units (ΔP_{WPP} and ΔP_{CHP}). The P_{ACE} , ΔP (total secondary dispatch), ΔP_{WPP} and ΔP_{CHP} are shown in Figure 99 and Figure 100 for Eastern and Western Danish power systems, respectively. The P_{ACE} is used as input signal in the PI controller to decide the necessary secondary response (ΔP_{sec}) from the participating generating units. The ΔP_{sec} lags behind P_{ACE} due to the delays in the AGC system and the delays associated with the power plants response. The activation of FRR (ΔP_{WPP} and ΔP_{CHP}) minimizes the total power imbalances which is replicated in the form of P_{ACE} .

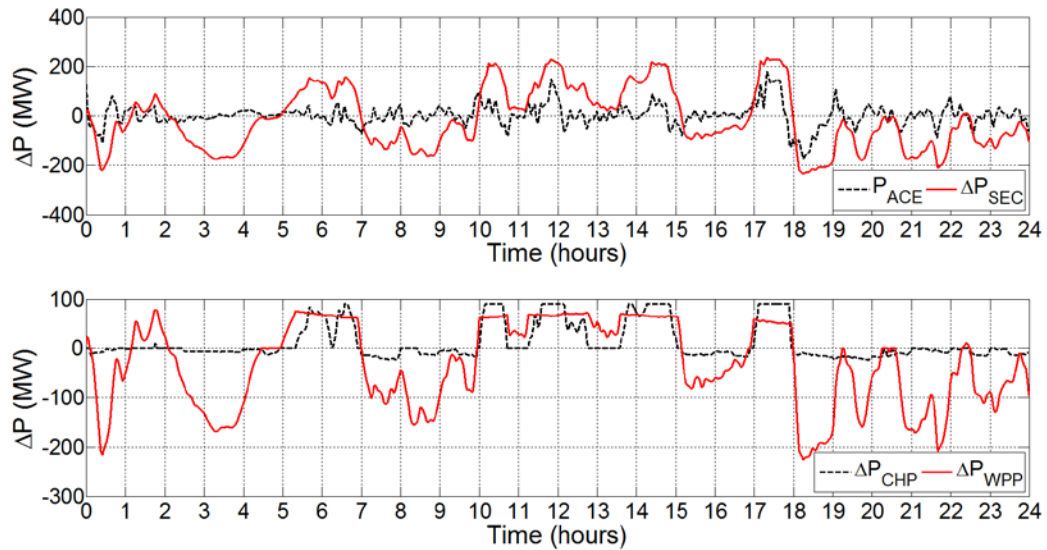

Figure 99: Eastern Denmark; top: P_{ACE} and ΔP , bottom: ΔP_{WPP} and ΔP_{CHP}

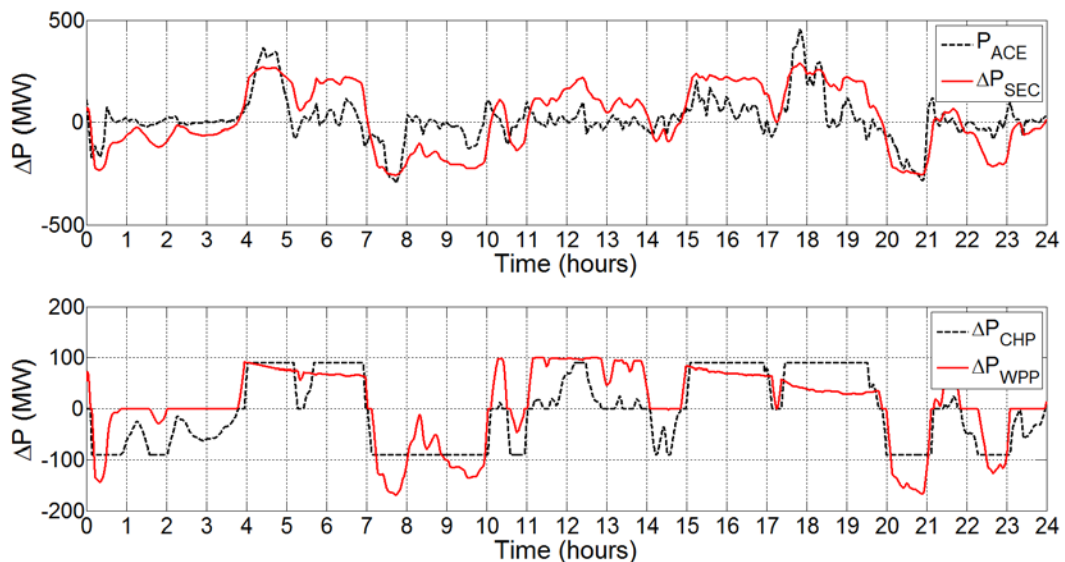

Figure 100: Western Denmark; top: P_{ACE} and ΔP , bottom: ΔP_{WPP} and ΔP_{CHP}

From above figures, ΔP_{CHP} is limited to ± 90 MW; whereas, the availability of wind power reserves for positive dispatch is dependent on the reference wind power, which is continuously

varying. During positive secondary dispatch, the CHP is dispatched only when wind power reserves are completely deployed, i.e. WPP starts generating the available power. However, during negative dispatch process, the WPP is down regulated only when CHP are unable to provide the required response. It can be noticed from Figure 99, that the negative dispatch for WPP starts before ΔP_{CHP} reaches to -90 MW. This is because the CHP is operating on its minimum limit. The online capacity of CHP in Eastern and Western Danish power systems on the particular day are 1754 MW and 1944 MW, respectively. However, CHP is frequently operating near the minimum operating point, i.e. 20% of the online capacity, as WPP are generating higher. The generation from CHP is shown in Figure 101, where the minimum operating limit is marked as dotted line. This scenario makes the WPP integration into the AGC system more interesting, as WPP can actively handle the positive power imbalance and minimizes the real-time regulation burden. If wind power is not integrated into the AGC control, the TSOs are require to purchase extra regulating power bids to minimize power imbalances, which increases the overall operation cost.

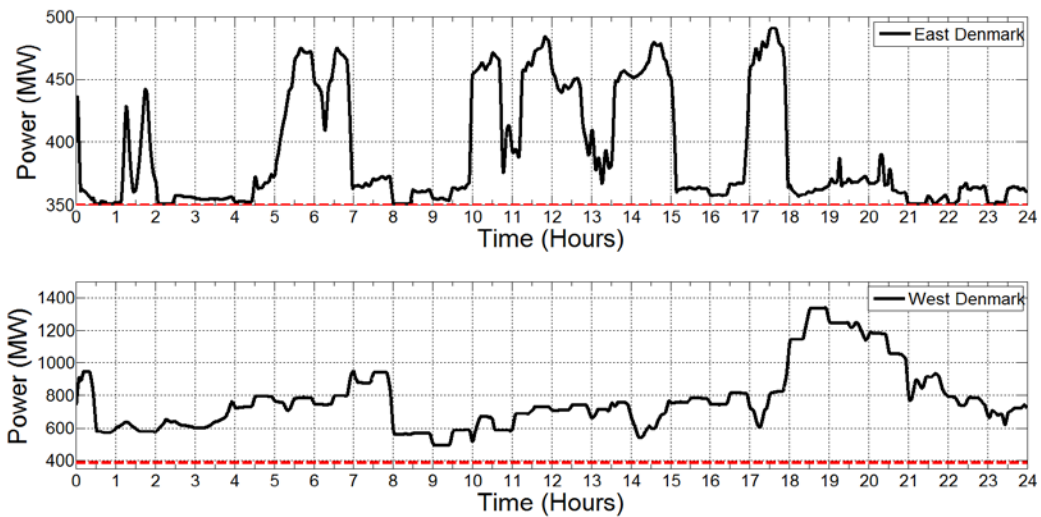

Figure 101: CHP generation

The power imbalances in Danish power system, seen as deviation in the power exchange from its schedule, is shown in Figure 102. The figure compares the power imbalances with and without integration of WPP. It can be noticed that the integration of WPP control into the AGC system reduces the power imbalances; especially the positive power imbalances.

As aforementioned, it is assumed that 3% of the available power is kept as reserve for upward regulation, i.e. 1.4 GWh in Eastern Denmark and 1.7 GWh in Western Denmark. However, the wind energy deployed during positive dispatch is only 0.514 GWh in Eastern Denmark and 0.804 GWh in Western Denmark, which is 36.17% and 47.3% of the reserve wind power in respective power systems. The amount of wind energy kept as reserve and not deployed, 0.886 GWh in Eastern Denmark and 0.896 GWh in Western Denmark, is the amount of wind power

lost on this specific day. This also means that the same amount of energy is produced from the conventional power plants, having higher incremental cost, thus increases the overall operational cost.

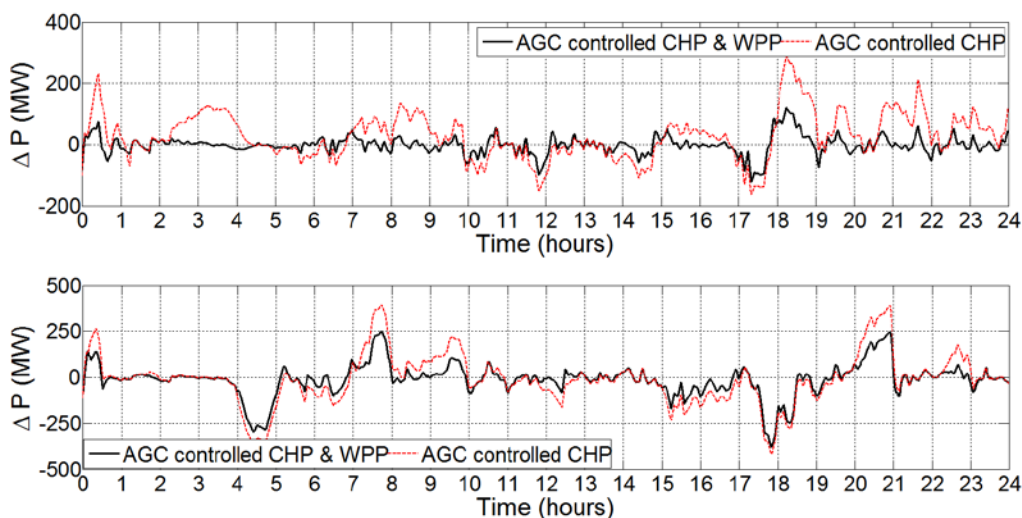

Figure 102: Power deviation on AC links; top: Eastern Denmark, bottom: Western Denmark

From this study, we can conclude that keeping wind power as reserve reduces the real-time power imbalances but increases the operational cost; however, the WPP reduces the operational cost and power imbalance if participate in down regulation services during positive power imbalances. The following study investigates the power system balance control, when WPP will generate the available power and de-regulate its production only when CHPs are unable to fulfil the AGC command.

6.3.2 WPP generating available power

Incremental cost associated with wind power is very little and therefore the TSOs try to utilize the available wind power as much as possible. The electricity market decides the dispatch plan for the generating units with the objective to minimize the supply cost while meeting the system load demand. However, the increasing large scale integration of wind power also requires active participation from WPP in maintaining the real-time power balance in the power system. This part of the case study examines the power balance control in a highly wind power integrated power system, when WPPs are utilizing the available wind power. The secondary dispatch process for this study is already explained in detail in section 4.3.2, where WPPs generating the available power only responds to down regulating services and CHPs manoeuvre its power set point during positive and negative power imbalances.

This study uses the same time series for generation, load and power exchange as the previous one, considering that the wind power reserves are not available. Unlike the previous case, the available wind power is 46.59 GWh in Eastern Denmark and 56.92 GWh in Western Denmark.

As previous cases, the available wind power is not the same as hour-ahead forecast and this aspect creates power imbalance within the operating hour. The real-time power imbalance is already shown in Figure 97, which is initially compensated by the primary response from generating units and synchronous power system and then the AGC response minimizes the deviation in system frequency and power exchange.

The secondary dispatch for the WPP and CHP in Eastern and Western Danish power systems are shown in Figure 103 and Figure 104, respectively. Notice that WPP only participate in the down regulating process, while CHP contributes in both up and down regulating processes. The down regulating secondary dispatch to the WPP (ΔP_{WPP}) is activated only when CHP are unable to provide the required response. As previous study, when CHP dispatch (ΔP_{CHP}) touches the lower limit (-90 MW) or they are operating at their lower generation limit (20% of the online capacity), this being quite frequently, the WPP regulates its production according to the AGC command.

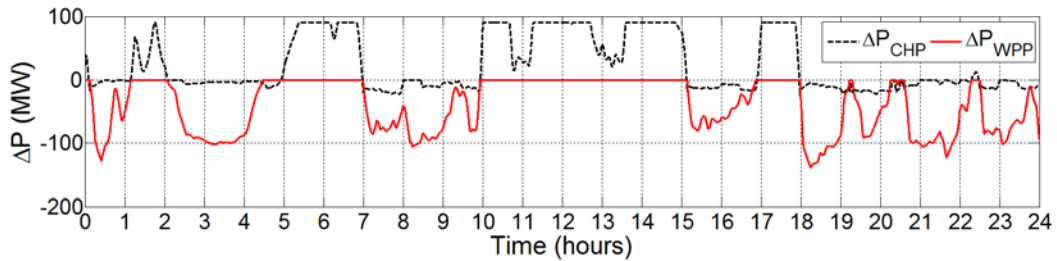

Figure 103: Secondary dispatch in Eastern Denmark

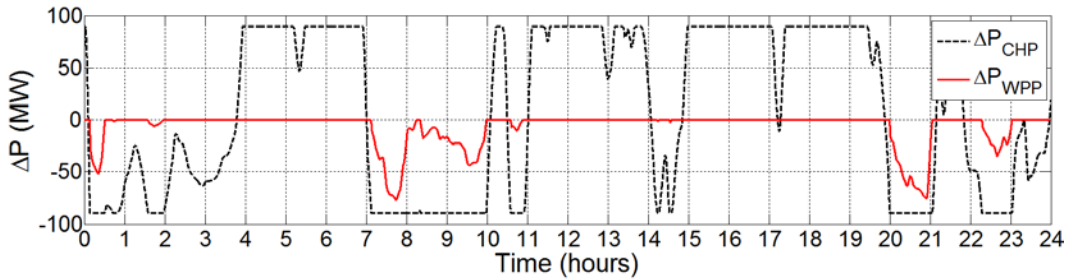

Figure 104: Secondary dispatch in Western Denmark

The wind power available and generated on the specific day is shown in Figure 105 and Figure 106 for Eastern and Western Danish power system, respectively. It can be noticed from these figures that the generated wind power (P_{WPP}) is not the same as available wind power, as some of the wind power has been utilized for active power balance control services. On the particular day, 46.6 GWh is the available wind energy in Eastern Denmark and 56.93 GWh in Western Denmark, out of which 1.02 GWh and 0.23 GWh is utilized by down regulating the WPP to compensate the real-time power imbalance, when CHPs are not able to provide the required response. This shows that active participation of WPP in AGC as an attractive solution for future power systems with large scale of wind power, while minimizing the overall operating cost. Without integration of WPP in AGC system, the TSOs will require regulating bids from

conventional power plant to handle these power imbalances which will result in high operating cost.

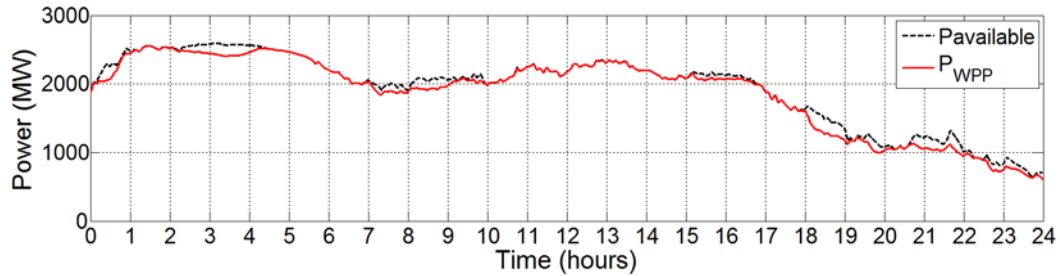

Figure 105: Eastern Denmark; available and generated wind power

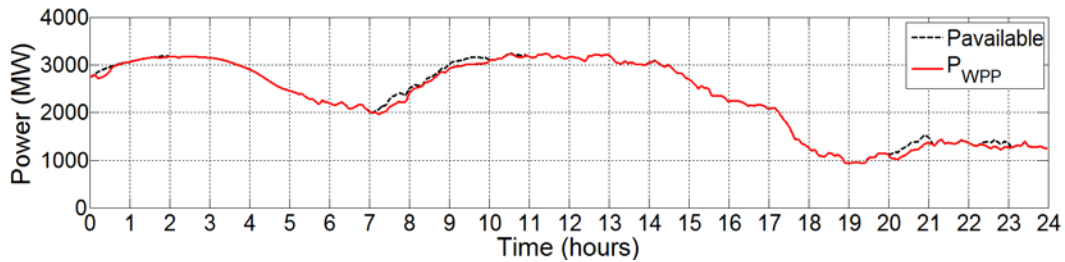

Figure 106: Western Denmark; available and generated wind power

Figure 107 compares the power imbalance in Eastern and Western Danish power systems, when WPP is generating available power, WPP contributing to up and down regulation with the regulating reserves and without the integration of WPP control into the AGC system.

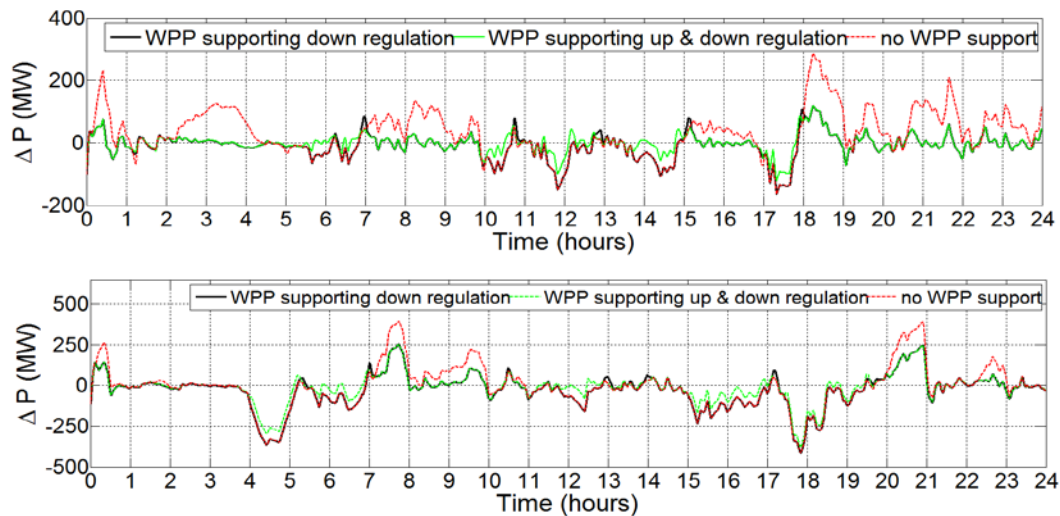

Figure 107: Power imbalances; top: Eastern Denmark, bottom: Western Denmark

It can be observed from this figure that the integration of WPP substantially reduces the power imbalances, especially in case of generation excess, as CHP are frequently operating at their minimum level due to high power generation from WPP. The integration and active participation of WPP in the AGC system reduces the real-time power imbalances, making power system

operation more reliable. The negative power imbalances are reduced with reserve wind power; however, it increases the overall operational cost as the wind power kept as reserve will be generated by the conventional generating units or imported from neighbouring power systems if not utilised in secondary dispatch process. Considering the lower incremental cost of wind power, it is better to use all the available wind power and down regulate its production during generation excess.

From this and previous study (section 6.3.1), we can conclude that the active integration of wind power into the dispatch of the AGC is an attractive active power balancing control solution for power systems with large scale wind power penetration. The strength of the solution is of high relevance particularly in situations when wind power is contributing highly to the total electricity production and when the conventional power plants are operating at the minimum level and cannot be further down regulated in case of generation excess. The down regulation of the wind power reduces the power imbalance in real-time operation and due to its fast ramp rates can also provide quick area control error compliance.

6.3.3 Analysis during critical weather condition

Secure power system operation of a highly wind power integrated power system is always at risk during critical weather conditions, e.g. in extreme high winds. The risk is even higher when 50% of the total electricity consumption has to be supplied by wind power, as the case for the future Danish power system in 2020. This part of the case study analyses the power balance control in future Danish power system during extreme wind speeds, where AGC regulates the WPP only during generation excess.

The storm controller ceases power generation from wind turbines during critical weather conditions, to prevent turbine from damage due to extreme mechanical loads. High Wind Shut Down (HWSD) is the typical storm controller installed in majority of the wind turbines. The HWSD controller halts the turbine operation when average wind speed reaches to a certain level. The average wind speed is based on 1 second, 30 seconds and 10 minutes. The HWSD behaviour is described by the power curve presented in Figure 108. The sudden cut off may result in active power balance/frequency control issues on power system level, depending on the wind power integration in the power system. In this study, HWSD storm controller is implemented in CorWind model, which provides the available wind power to SimBa and the dynamic power system model.

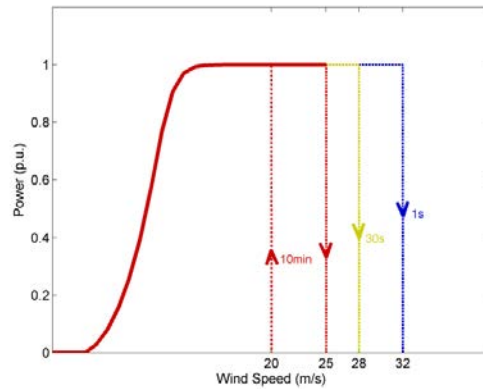

Figure 108: HWSD; wind power curve

A set of simulations are performed using the time series for generation, load and power exchange corresponding to a scenario with extreme high wind speeds. The time series are generated by SimBa for the future Danish power system (2020) based on the real data from the year 2009 (October 3 18:00 – October 4 12:00). The power system comes out of balance if the available wind power generated within the operating hour differs from the hour-ahead forecast. The power imbalance yields to a change in the system frequency and deviation in power exchange from hour-ahead schedule. The power imbalance is worse if the forecasting error leads to wind turbine cut off (during storms). Figure 109 shows the available wind power and the hour-ahead forecasted wind power and Figure 110 shows the difference of available and forecasted wind power, i.e. hour-ahead wind power forecast error.

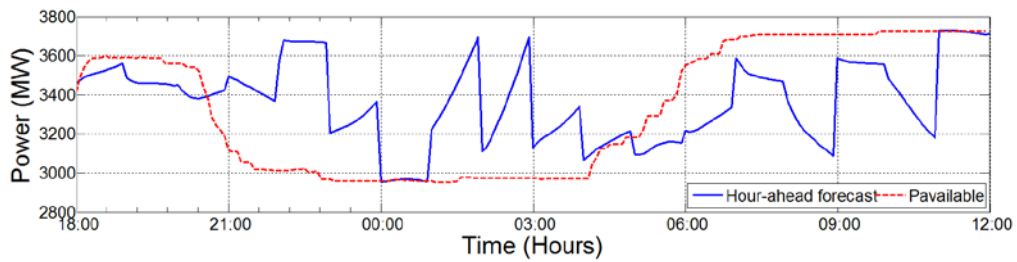

Figure 109: Hour-ahead forecast and available wind power

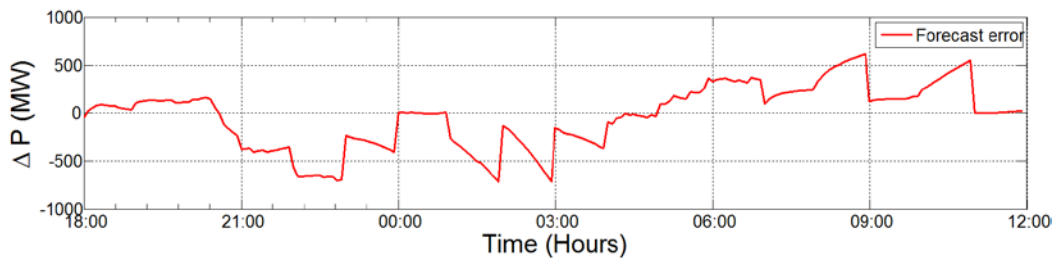

Figure 110: Hour-ahead wind power forecast error

It can be observed from above figures that the critical weather condition in a large scale wind power integrated power system leads to huge power imbalances. The power imbalances can be

negative, when wind turbines halt operation due to extreme winds and also positive when wind turbines unexpectedly continue to operate. The positive and negative power imbalances during critical weather condition can be observed in above figures, where wind turbines cut off during time 20:00 – 04:00 leads to negative power imbalances and unpredictably the wind turbines operation during 04:00 – 11:00 generates positive power imbalances.

The developed power system model will initially compensate the power imbalance through activation of FCR, which depends on the power frequency characteristics of the generating unit in Danish power system and the synchronous power system. The AGC response will then activate the FRR and tries to reduce power imbalance. However, in this study the large power imbalances can be partially compensated with the secondary control power from CHP and WPP. The AGC calculates the P_{ACE} based on the frequency deviation from nominal level and deviation in power exchange from its schedule. The PI controller processes the P_{ACE} to calculate the required secondary response ΔP_{SEC} , which is then distributed among participating generating units through secondary dispatch block (ΔP_{CHP} and ΔP_{WPP}). The dispatch process is shown in Figure 111. As aforementioned, that the WPP generates the available power so ΔP_{WPP} is activated only during positive power imbalances, while ΔP_{CHP} responds to negative or positive power imbalances and is limited to ± 90 MW. Also, the ΔP_{WPP} is activated only when CHP are unable to provide the required response, namely that when the ΔP_{CHP} touches the lower limit (-90 MW) or they are operating at their lower generation limit (20% of the online capacity).

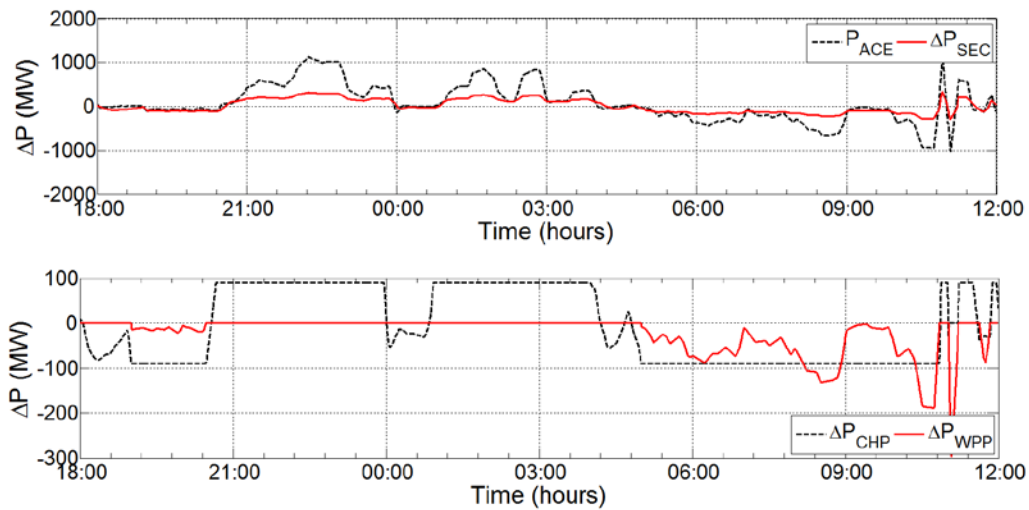

Figure 111: AGC response; P_{ACE} , ΔP_{SEC} , ΔP_{CHP} and ΔP_{WPP}

Figure 112 compares the initial power imbalance with the final power imbalances. The coordinated AGC control between CHP and WPP minimizes the real-time power imbalances and makes the power system operation more reliable.

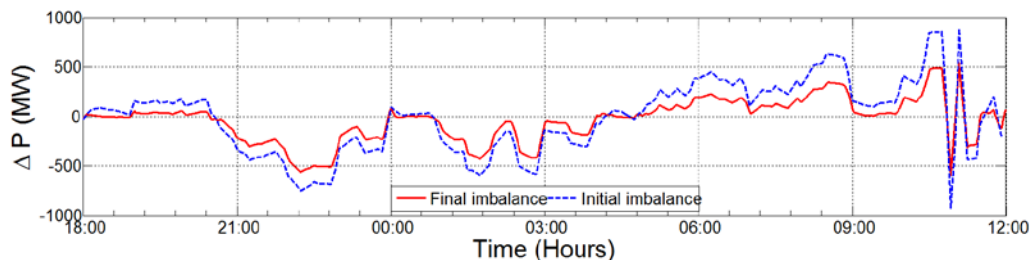

Figure 112: Power imbalances during extreme weather conditions

From this study we can conclude, that the large scale integration of wind power challenges the reliable operation of power system, especially during critical weather condition, e.g. extreme high wind speeds. If not forecasted, these conditions may result in a high power imbalance. However, the availability of operating reserves and active participation of WPP in power balance control makes the power system operation more reliable.

6.4 Impact of programmed regulating reserves

Effective control of regulating power is required in real-time for the reliable and secure operation of future power system with large scale integration of wind power. The above studies show that AGC minimizes the real-time power imbalances; however, large and sustained power imbalances require activation of manual reserves. These reserves are activated by the control room operator, in order to restore the automatic FRR for future use and also to reduce the power imbalances and operational cost by re-distributing the required power economically among various generators. In this study, the manual reserves are activated with a heuristic algorithm ‘rolling balance’. The algorithm has already been discussed in detail in section 4.4.

The objective of this case study is to analyse real-time active power balance control with coordinated AGC action between CHP and WPP and by activating the regulating power bids through rolling balance. The active power control methodology is applied and investigated on future Danish power system model. Like previous case studies, the model takes the hour-ahead regulating power plan from SimBa and the generation and power exchange capacities for the year 2020 into account. The conventional generation and the power exchange are using hour-ahead time series, while WPP generates the available wind power. Power imbalance appears within the operating hour, if HA wind power forecast is not the same as available wind power. This imbalance is compensated by AGC and by activating regulating bids from CHPs through rolling balance.

The system behaviour of a large scale wind power integrated power system is investigated on a particular day with high wind and load demand. The availability of wind allows the WPPs to generate more power than conventional power plants and positive power exports with neighbouring power systems. The net power exports are calculated by subtracting the total export

power from total import power with neighbouring power systems. On the specific day in Eastern Denmark, the conventional power plants generated 33.31 GWh of electricity, while WPPs generated 43.2 GWh, i.e. 56.46% of the total electricity production. The high production from WPPs allows the power exports of 32.75 GWh from Eastern Danish power system, when the load demand was 43.75 GWh. Similarly in Western Denmark, 45.77 GWh is generated from conventional power plants and 59.53 GWh from WPP, i.e. 56.53%. While, the total load demand and the power exports are 63.98 GWh and 41.27 GWh, respectively. It can also be noted that on specific day, WPP contributed 98.7% and 93% of the total load demand in Eastern and Western Danish power system, respectively. As aforementioned, the wrong wind power forecast creates an imbalance between generation and load demand within the operating hour, departing the system frequency from its nominal level. The power imbalance in real-time is shown in Figure 113.

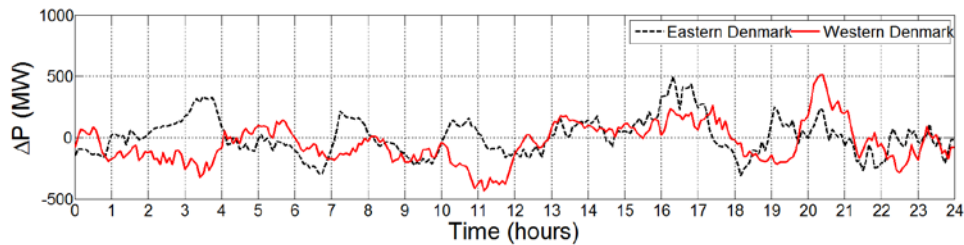

Figure 113: Initial power imbalance

In response, the generating units equipped with speed governors and the synchronous power system releases FCR. The primary response from the synchronous power system will appear as deviation in power exchange from its schedule. To return the system frequency to its nominal level and power exchange to its schedule, the AGC provides the secondary response. The AGC calculates the ΔP_{sec} from P_{ACE} and then distribute it among the participating generators, i.e. CHP and WPP. The secondary dispatch for CHP (ΔP_{CHP}) and WPP (ΔP_{WPP}) is shown in Figure 114.

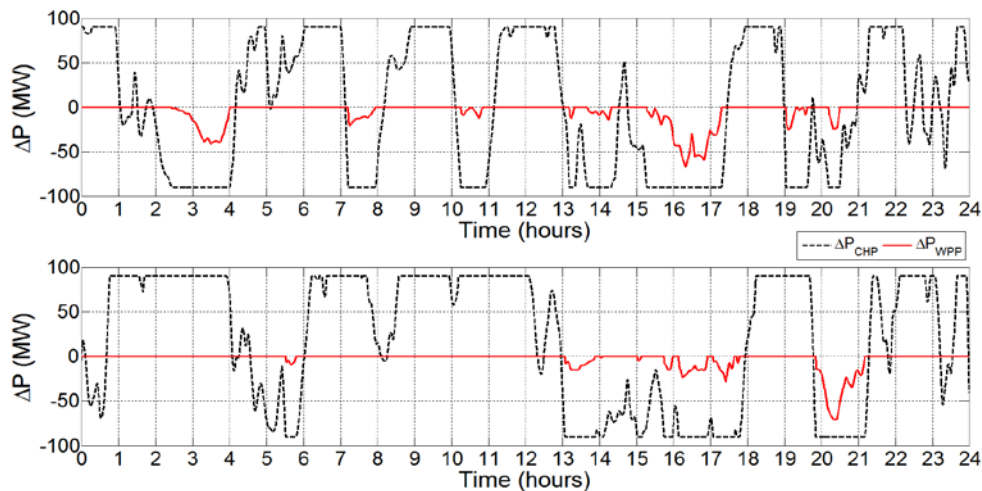

Figure 114: Secondary dispatch; top: Eastern Denmark, bottom: Western Denmark

The secondary dispatch provides new set points to the CHP and WPP, based on the operating conditions of CHP and WPP. From above figure, WPPs only participate in the down regulating process, while CHPs contributes in both up and down regulating processes. The ΔP_{CHP} is again limited by ± 90 MW, and the WPP is down regulated only when CHPs are unable to provide the required response.

In order to reduce the real-time power imbalance and restores the secondary reserves, the *rolling balance* activates the regulating bids where the process is almost similar to the control room operator's response. The *rolling balance* activates the bids if the imbalance is greater than threshold level (30 MW considered for this study) and persists for three periods, i.e. 15 minutes. The regulating bid is activated at the start of third period and equals to the minimum imbalance of three consecutive periods, while the AGC directly responds to the power imbalance. The regulating power activated by the *rolling balance* is shown in Figure 115. The resulting AGC dispatch after the activation of regulating power is shown in Figure 116 and it can be noticed that the rolling balance minimizes the power imbalance and thereby reduces the regulating burden.

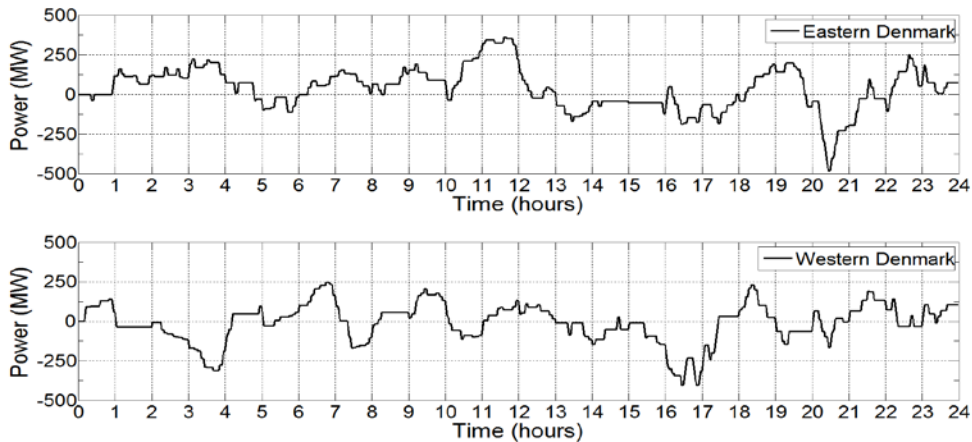

Figure 115: Regulating power activated in Eastern & Western Danish power systems

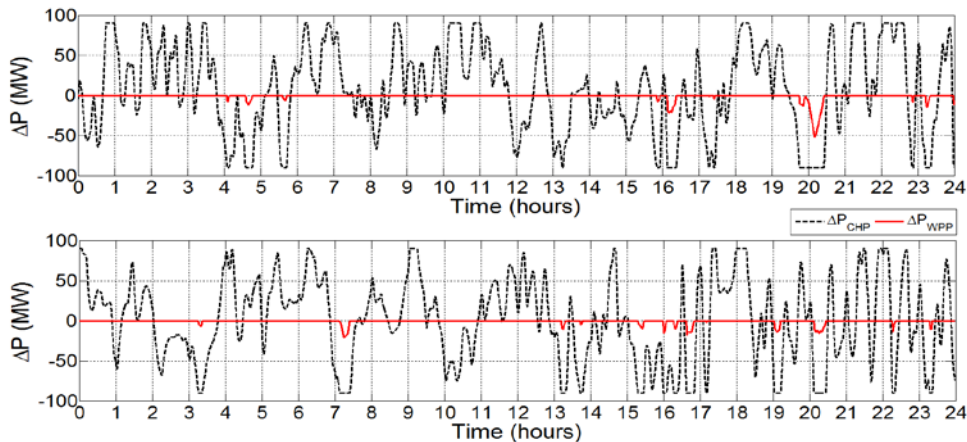

Figure 116: Secondary dispatch with rolling balance; top: Eastern Denmark, bottom: Western Denmark

Activating the regulating bids through *rolling balance* not only reduces the real-time active power imbalance but makes the power system operation more reliable and secure. Figure 117 and Figure 118 respectively compares the power imbalance in Eastern and Western Danish power systems, when:

- (A) – Real-time control is provided with coordinated AGC and rolling balance
- (B) – Real-time control is provided with coordinated AGC
- (C) – Initial power imbalance

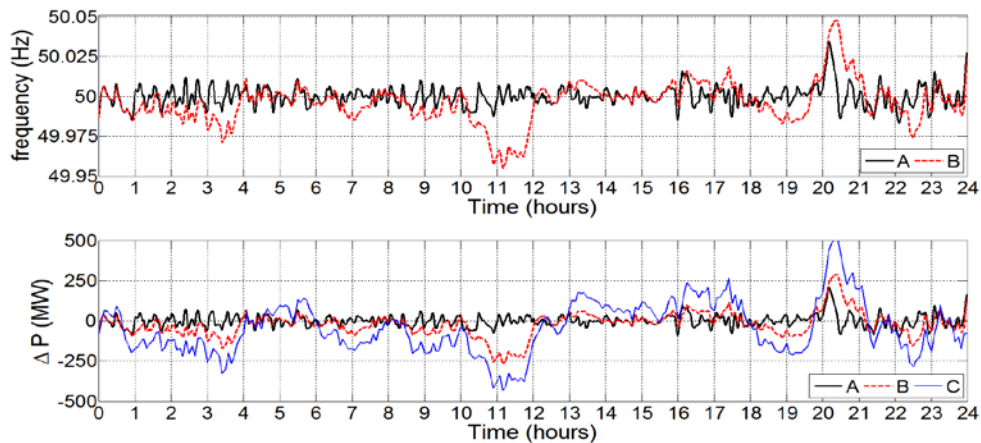

Figure 117: Eastern Danish power system; top: system frequency, bottom: Power imbalance

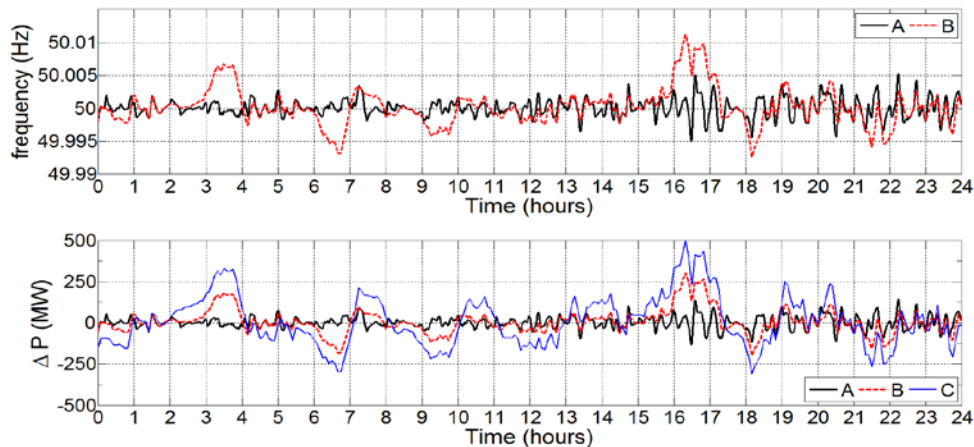

Figure 118: Western Danish power system; top: system frequency, bottom: Power imbalance

It can be noticed that the power imbalance has decreased substantially with the proposed active power balance technique, i.e. when real-time control is provided with coordinated AGC and *rolling balance*. These figures also show that the deviation in system frequencies from their nominal level minimizes with the activation of regulating power. Although the strong

neighbouring interconnections limit frequency change and maintain them within the acceptable range.

Regulating power in a deregulated power system is always needed to increase system reliability and to ensure power supply security. The need for regulating reserves is growing with increasing integration wind power. Beside this, effective way of bids activation is also of high importance. This study case activates the regulating power bids from conventional power plants; however, the WPPs can be effectively used for the activation negative regulating bids in situations when conventional power plants are operating on their minimum level.

6.5 Integration of consumption units and WPP in AGC system

Previous case studies show that the conventional power plants are always required to provide support during active power imbalances. The WPPs can contribute actively in power balance control, providing up and down regulation services, but keeping the wind power as reserves increases the operational cost. The study shows that it is economically advantageous to generate the available wind power and down regulate its production during positive power balance. This situation is more preferable when CHPs are operating on their minimum level. However, this case study analyses the operation of future Danish power system when real-time power imbalances are minimized by regulating the WPP production during positive power imbalances and load consumption during negative power imbalances.

The motivation for this case study is the analysis carried out in [70] for future Danish power system. According to the study, the flexible consumption units in Danish system are capable of providing ancillary services. The cold storage and electric vehicles are examined in that case for regulation services (secondary and tertiary), which eases the operator's burden of forecasting and supervising the operation of highly wind power integrated power system and decrease the overall system costs by lowering the production from conventional thermal power plants. According to the mentioned study, the consumption units have potential for shifting the energy for several hours in order to provide ancillary services, without compromising the primary function of their operation. The study also estimates the flexible consumption units in Denmark in 2020, i.e. 200 MW of cold storage and 75000 of electric vehicles (600MW). However, the present case study assumes that 90 MW is available for secondary control purposes which are controlled through AGC during negative power imbalances.

A set of simulations has been carried out to illustrate the dynamic performance of the proposed active power balanced control strategy. The simulations are performed using the time series from section 6.3.2 for generation, load and power exchange. Table 9 summarizes the available wind power, conventional power generation, load demand and net power exports on this particular day.

Table 9: Wind energy, conventional energy, load demand and net exports

	Eastern Denmark	Western Denmark
Available wind (GWh)	46.59	56.92
Conventional generation (GWh)	14.12	26.67
Load demand (GWh)	30.84	47.92
Net exports (GWh)	29.38	36

As previous case studies, the power imbalance in real time appears if available wind power is not same as hour-ahead wind power forecast. The FCR provides the initial support and activation of FRR through AGC minimizes the deviation in system frequency from its nominal level and deviation in power exchange from its schedule. As aforementioned, the secondary regulation is provided by the WPP and the flexible load (cold storage & electric vehicles).

The AGC estimates the power imbalance (P_{ACE}) in each part of the Danish power system from power exchange deviation and error in the system frequency. The PI controller then processes P_{ACE} for the calculation of required secondary response, i.e. ΔP_{SEC} . The ΔP_{SEC} is distributed among the participating units through dispatch strategy, i.e. flexible consumption units and WPPs. The activation of FRR minimizes the P_{ACE} , as shown in Figure 119 and Figure 120. These figures also shows secondary dispatch process, where load consumption is down regulated in case of positive demand and WPP is down regulated in events of generation excess.

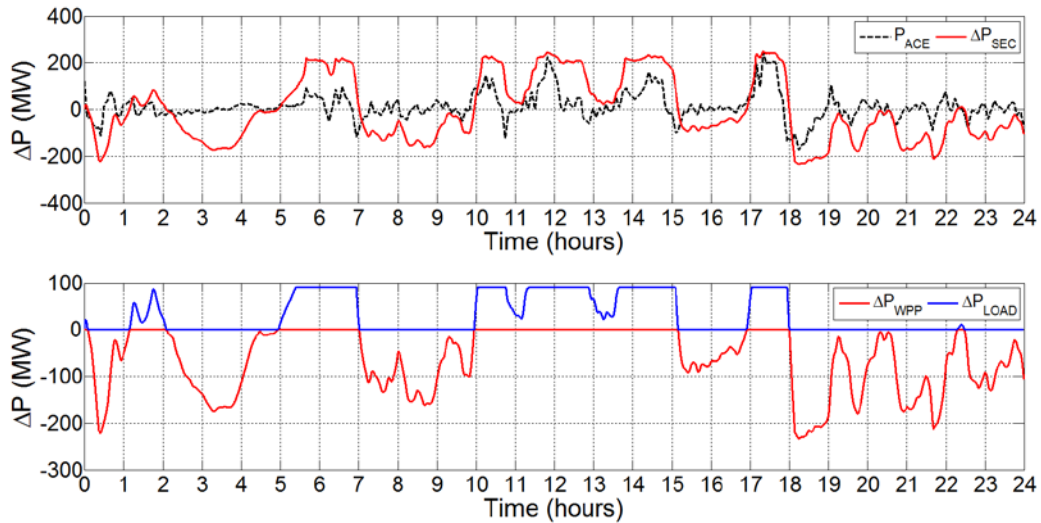

Figure 119: Eastern Denmark; P_{ACE} , ΔP_{SEC} , ΔP_{WPP} and ΔP_{LOAD}

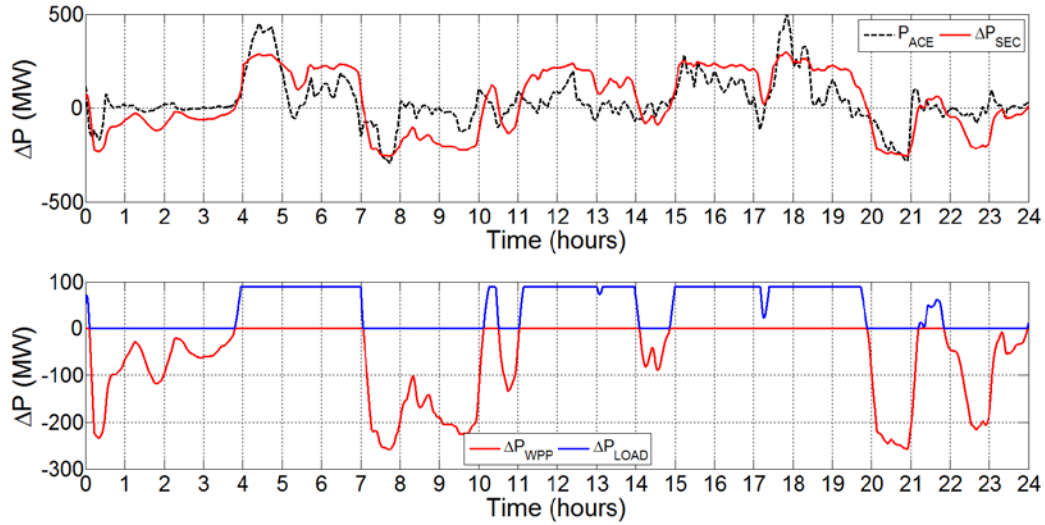

Figure 120: Western Denmark; P_{ACE} , ΔP_{SEC} , ΔP_{WPP} and ΔP_{LOAD}

The secondary response from the consumption units and the WPP reduces the real-time power imbalances and hence the error in system frequency. Figure 121 and Figure 122 shows the system frequency and the power exchange deviation from its schedule. These figures compare the secondary control process when required response is provided with consumption units and WPP, i.e. the case under study, and when it is provided by the CHP and WPP. The figures show that the response in system frequency and power exchange is almost identical, except for some overshoot due to slower response from the CHP. This is shown in Figure 123, which provides the zoom view of power exchange deviation in Eastern Denmark around 18:00 hour.

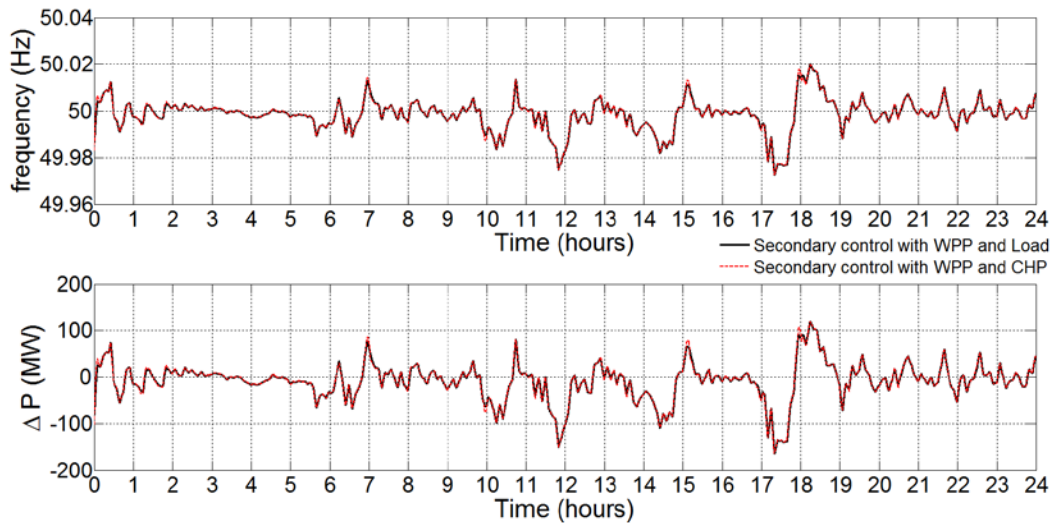

Figure 121: Eastern Denmark; top: system frequency, bottom: power exchange deviation

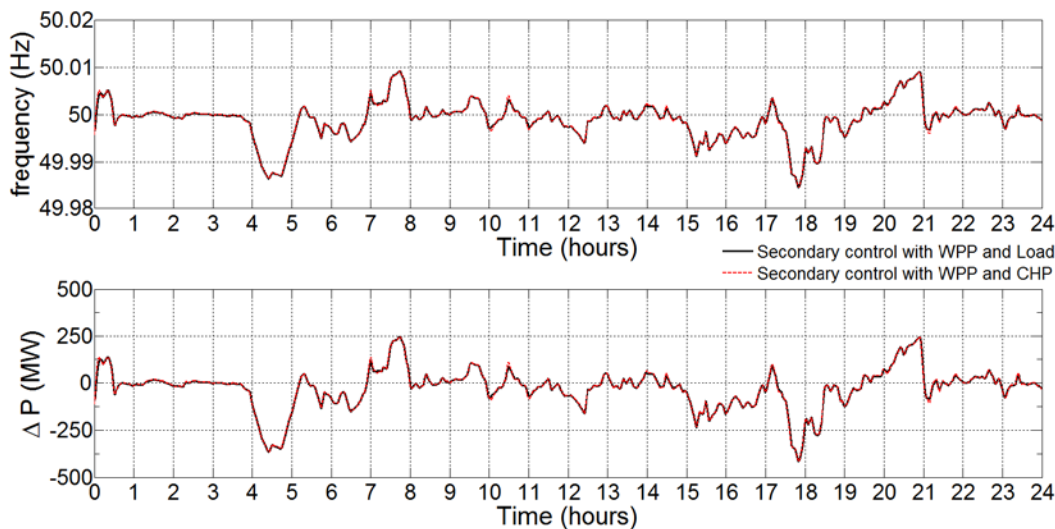

Figure 122: Western Denmark; top: system frequency, bottom: power exchange deviation

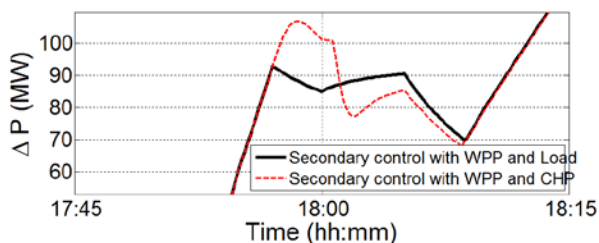

Figure 123: Zoom view of power exchange deviation in Eastern Denmark

The CHP response is dependent on the ramp rate limitation and the boiler dynamics, while the consumption units respond instantly. However, the above figures shows that the response is almost identical and this is due to the slower AGC response which dominates the overall power system response. During the secondary control process, the AGC down regulated 1.4 GWh of wind energy in Eastern Denmark and 1.38 GWh in Western Denmark on the particular day during generation excess. However, during generation deficit, the AGC down regulated the consumption units by 0.699 GWh in Eastern Denmark and 1.033 GWh in Western Denmark.

This study shows that the power imbalances in future Danish power system can be controlled with WPP and flexible consumption units, when conventional power plants only participates in primary control purposes. This eases the system operator’s burden of supervising the operation of highly wind power integrated power system and allows them to operate power system with minimum conventional power plants, thereby reducing the overall operation cost. As it has already been discussed that the large scale integration of wind power demands increase in regulating power reserves; however, employing wind power and flexible consumption units (such as cold storage units and electric vehicles) in secondary control process facilities the system operators in maintaining the real-time power balance control.

6.6 Summary

This chapter studied the power balance control in a future Danish power with large scale integration of wind power. The dynamic response of the power system model, developed in Chapter 4 and Chapter 5, is initially analysed. The analyses show that the primary response depends on the power frequency characteristics of the synchronous power system, and therefore the large synchronous power system with higher frequency response results in lower frequency deviation. During power imbalances, the generating units equipped with speed governors provides the required response in less than 30 seconds; however, this response deviates the power exchange from its schedule. The secondary response from the AGC minimizes these deviations within 8 – 10 minutes, depending on the availability of FRR.

This chapter then analysed the real-time power balance control, when inputs for generating units, power exchange and load are provided by the hour-ahead power balancing model, SimBa. The power system model uses the scheduled time series for conventional generating units and power exchange, while available wind power for WPPs. The real-time power imbalances, due to the wrong forecast of wind power, are then minimized through AGC.

The above studies analysed the active power balance in different scenarios, when conventional power plants are generating lower than the WPPs. The studies show that the power imbalances can be minimized only with CHP response; however, the integration of WPPs control in AGC system is effective when CHPs are operating on their minimum level. The integration of WPPs in AGC control minimizes the real-time power imbalances and reduces the operational cost. The wind power reserves, if not utilized, results in a higher generation cost and therefore this study suggests to generate the available wind power and down regulate the WPPs only during generation excess. This chapter also analysed the activation of regulating power reserves to minimize the sustained and large power imbalances and also to restore FCR and FRR for future reuse. These reserves are activated through a heuristic algorithm, taking in account that the power imbalances are sustained and larger than the threshold level. The activation of regulating reserves in a high wind power integrated power system resulted in lower power imbalances and makes the power system operation more reliable.

This chapter at the end analysed an important and cost effective case, where conventional power plants do not participate in secondary control. This case study shows that the integration of flexible consumption units and WPPs into the AGC system is as effective in controlling active power imbalances as CHPs and WPPs. The integration of flexible consumption units and WPPs eases the TSOs burden of forecasting and supervising the operation of highly wind power integrated power system and decrease the overall system costs by lowering the production from conventional power plants.

Chapter 7

Conclusions and future work

Large scale integration of wind power brings new challenges to the power system operation, raising serious concerns over its dynamic security and reliability. The increasing integration of wind power might replace some of the traditional power plants, currently responsible for real-time power balance control. The existing operational strategies of the power system therefore need to be revised for the operational security of modern power system. This thesis analysed the active participation of WPPs in the power balance control of large wind power integrated power system, where they contribute to primary and secondary control in a similar way as conventional power plants do.

7.1 Conclusions

In this thesis, the methodologies for active balance control of a large scale wind power integrated power system have been investigated. The Danish power system model is developed for this purpose, taking the expected generation and power exchange capacities for the year 2020 into account. The developed power system model includes AGC, aggregated models for CHP, DCHP and WPP and interconnections with neighbouring power system. The interconnections are modelled as simple load and an external grid is used to study the dynamics of the AC interconnections, emulating specific characteristics (inertia and frequency response) of CE and Nordic power systems.

Aggregated models for the generating units are developed to reduce the computation effort but still contain the dynamic features relevant for specific study, i.e. active power balance control. The models contain all subsystems and time constants that are important for long-term dynamic simulation studies. The performances of these models are first evaluated individually, and then together. SimBa model, which is an hour-ahead power balancing model, provides the time series for generation, power exchange and load in order to analyse the real-time power balance control in future Danish power system. SimBa model generates the hour-ahead balanced time series while taking into account the market rules, variable wind power generation and technical capabilities of the generating units.

The intermittent nature of wind power in a highly wind power integrated power system may result in real-time power imbalances which are then compensated through AGC response. This study has proposed and presented a novel and practical approach of integrating the WPP control into the AGC. This is based on a coordinated control strategy between CHPs and WPPs. It has been noticed that the coordinated control strategy improves the active power balance in the power system with minimum secondary dispatch cost. In this respect, the control strategy regulates the active power production from CHPs and WPPs, depending on operating reserves, dispatch limit and the generating cost. The WPPs can provide up or down regulation services, conditional to the availability of wind power reserve. Moreover, this study has also analysed the case where secondary control is provided by WPPs and consumption units, where AGC down regulates the flexible load during negative power imbalances and the WPP production during positive power imbalances. This PhD thesis has also developed an algorithm for the activation of manual reserves. The algorithm named as ‘rolling balance’ emulates the control room response, while activating the regulating power for secure power system operation.

The main outcomes from this study are summarized below:

- *The primary response and the frequency deviation from its nominal level depend on the power frequency characteristics of the synchronous power system, whereas main factors influencing the secondary response are the delays associated with the AGC and the generating units.*
- *In a highly wind power integrated power system, integration of WPPs into the AGC dispatch is an attractive solution for active power balance control. The active participation of WPPs reduces the real time power imbalances and makes power system operational more reliable.*
- *The WPPs can provide up and down regulation services; however, keeping wind power as reserve is not an economical solution. This is because that the wind power, cheapest source for electricity production, is lost if it is not utilized during secondary control process. On contrary, if WPPs generate the available wind power but it regulates its production only during generation excess, it proves to be the most cost effective mean of integrating WPP control into AGC system. The WPPs reduce the real-time power imbalances when CHPs are unable to provide required secondary response. This setup is especially useful when conventional power plants are operating on their minimum level due to high wind power generation. This can also provide freedom to the system operator to generate the available wind power and operate the conventional generating unit on their minimum level, without risking the reliable operation of highly wind power integrated power system.*

- *The sustained power imbalances and prolonged activated FRR can be restored with an effective activation of manual reserves, thereby increasing the system reliability and minimizing the operational cost.*
- *Integration of flexible consumptions units together with the WPPs into the AGC system can be useful for handling the real-time power imbalances, where consumption units regulate the flexible load during negative power imbalances and WPPs down regulate their production during positive power imbalances. This reduces the operator's burden of forecasting and supervising the operation of highly wind power integrated power system and decreases the overall system costs by lowering the production from conventional thermal power plants. However, conventional power plants will still be required to provide primary and tertiary control services.*

7.2 Future work

The objectives stated for the thesis are achieved within the scope and limitations. However, some suggestions for future work are as follows:

- *Aggregated models of WPPs and CHPs are here integrated into the AGC without taking the transmission congestion in consideration. The study can be extended to the limitations by modelling number of wind farms and centralized thermal power plants and study the secondary dispatch process, while taking into account the transmission congestion and transmission losses. Moreover, considering the cost functions for each wind farm and centralized thermal power plants can also provide more realistic and cost effective secondary dispatch.*
- *Modifications in market rules for allowing wind power integration into the AGC, where WPPs participate in power balancing operation only during positive imbalances can be considered. This can allow the WPPs to generate available wind power and conventional power plants to operate on their minimum limit, reducing thus the overall operational cost without effecting the reliable operation of a highly wind power integrated power system.*
- *An aggregated model for WPP is developed for a specific study, i.e. active power balance control and the modelling do not consider the inertial response from WPP. The aggregated model can be further extended to number of wind farms, with the specific aim of studying the inertial response especially during critical weather conditions resulting in huge power imbalances. The inertial response can be analysed solely from the wind turbines and also combined with energy storage devices.*

Wind Power Plant System Services

- *This study has analysed the power balance control during normal situations when frequency deviations are minimized by the stiff and large CE and Nordic power systems. However, for future Danish power system it is also important to study the frequency control during contingency events, e.g. tripping of AC interconnection, where only generating units in the Danish power system and the HVDC links contribute to frequency control.*
- *This study didn't consider the reactive power capability of the WPP. It could also be relevant to study the real-time reactive power control from wind farm, where HVDC connected WPPs contributes to voltage recovery following grid faults.*

References

- [1] GWEC, “Global wind report - Annual market report,” GWEC, October 2014.
- [2] Iben B. Spliid, “Stamdataregister for vindmøller,” Danish Energy Agency, [Online]. Available: <http://www.ens.dk/info/tal-kort/statistik-noegletal/oversigt-energisektoren/stamdataregister-vindmoller>. [Accessed 20 October 2014].
- [3] Vittrup, C., “2013 was a record-setting year for Danish wind power,” Energinet.dk, 2014.
- [4] Danish Wind Industry Association, “WIND ENERGY,” Ministry of Foreign Affairs of Denmark, [Online]. Available: <http://denmark.dk/en/green-living/wind-energy/>. [Accessed 11 12 2014].
- [5] Rather Z.H.; Chen Z.; Thogersen P., “Challenges of Danish power system and their possible solutions,” in *IEEE International Conference on Power System Technology (POWERCON)*, 2012.
- [6] Suwannarat, A., “Integration and Control of Wind Farms in the Danish Electricity System,” Institute of Energy Technology Aalborg University, Aalborg, 2007.
- [7] Suwannarat A., Birgitte B.J., Chen Z., “Power System Stability with Large-Scale Wind Power Penetration,” in *IASTED International Conference on Energy and Power Systems, AsiaPES*, Phuket, 2007.
- [8] Giannopoulos, G., “Frequency control in area with large scale wind power,” Denmark Technical University, Roskilde, 2012.
- [9] Suwannarat A., Birgitte B.J., Chen Z., Nielsen H., Hjerrild J., Sørensen P., Hansen A.D., “Power Balancing Control with Large-Scale Wind Power Penetration in Denmark,” in *IASTED International Conference on Power and Energy Systems, EuroPES 2007*, Palma de Mallorca, 2007.

- [10] Suwannarat A., Birgitte B.J., Chen Z., Nielsen H., Hjerrild J., Sørensen P., Hansen A.D., “Power System Operation with Large-Scale Wind Power Penetration,” in *Power Tech 2007*, Lausanne, 2007.
- [11] Basit A., Hansen A.D., Sorensen P., Altin M., “Balancing modern Power System with large scale of wind power,” in *China Wind Power (CWP)*, Beijing, 2014.
- [12] Basit A., Hansen A.D., Sorensen P., Altin M., “Analysis of Highly Wind Power Integrated Power System model performance during Critical Weather conditions,” in *Wind Integration Workshop (WIW14)*, Berlin, 2014.
- [13] Cutululis N.A., Palima M.L., Sorensen P., Bjerger M.H., Detlefsen N., “Impact of high wind speed shut-down in the Danish power system,” in *Wind Integration Workshop (WIW12)*, London, UK, 2012.
- [14] Basit A., Hansen A.D., Sorensen P., “Dynamic model of frequency control in Danish power system with large scale integration of wind power,” in *China Wind Power (CWP)*, Beijing, 2013.
- [15] Karas, M.A., “Wind power to combat climate change - how to integrate wind energy into the power system,” Energinet.dk, [Online]. Available: <http://energinet.dk/SiteCollectionDocuments/Engelske%20dokumenter/Klimaogmiljo/Wind%20power%20magazine.pdf>. [Accessed 21 October 2014].
- [16] Eltra/Elkraft, “Regulation TF 3.2.5, Wind turbines connected to grids with voltages above 100 kV,” Energinet.dk, Denmark, 2004.
- [17] Eltra/Elkraft, “Technical Regulation TF 3.2.6, Wind turbines connected to grids with voltages below 100 kV,” Energinet.dk, 2004.
- [18] National Grid, “The Grid Code,” UK, August 2011.
- [19] ENTSO-E, “ENTSO-E Network Code for Requirements for Grid Connection Applicable to all Generators,” ENTSO-E, March 2013.
- [20] Almeida R.G., Castronuovo E.D., Lopes J.A.P., “Optimum generation control in wind parks when carrying out system operator requests,” *IEEE Transactions on Power Systems*, vol. 21, no. 2, pp. 718 - 725, May 2006.

- [21] Janssens N.A., Lambin G., Bragard N. , “Active power control strategies of DFIG wind turbines,” *IEEE power tech Lausanne*, pp. 516-521, 2007.
- [22] Kanellos F.D., Hatziargyriou N.D., “Control of variable speed wind turbines in islanded mode of operation,” *IEEE Transactions on Energy Conversion*, vol. 23, no. 2, pp. 535-543, June 2008.
- [23] Courtecuisse V., Robyns B., Francois B., Petit M., Deuse J., “Variable speed wind generators participation in primary frequency control,” *Wind Engineering*, vol. 32, no. 3, pp. 299-318, 2008.
- [24] Holdsworth L., Ekanayake J.B., Jenkins N., “Power system frequency response from fixed speed and doubly fed induction generator-based wind turbines,” *Wind Energy*, vol. 7, no. 1, pp. 21-35, 2004.
- [25] Moutis P., Loukarakis E., Papathanasiou S., Hatziargyriou N.D., “Primary load-frequency control from pitch-controlled wind turbines,” *IEEE power tech Bucharest*, pp. 1 - 7, 2009.
- [26] BOUSSEAU P., et. al., “CONTRIBUTION OF WIND FARMS TO ANCILLARY SERVICES,” in *CIGRE*, Paris, 2006.
- [27] Ullah, N.R.; Thiringer, T.; Karlsson, D., “Temporary Primary Frequency Control Support by Variable Speed Wind Turbines— Potential and Applications,” *IEEE Transactions on Power Systems*, vol. 23, no. 2, pp. 601 - 612, May 2008.
- [28] Moutis P., Papathanassiou S.A., Hatziargyriou N.D., “Improved load-frequency control contribution of variable speed variable pitch wind generators,” *Renewable Energy*, vol. 48, pp. 514 - 523 , December 2012.
- [29] Rodriguez-Amenedo J. L., Arnalte S., Burgos J. C., “Automatic Generation Control of a Wind Farm With Variable Speed Wind Turbines,” *IEEE Transactions on Energy Conversion*, vol. 17, no. 2, pp. 279 - 284, 2002.
- [30] Hansen A. D., Sørensen P., Iov F., Blaabjerg F., “Centralised power control of wind farm with doubly fed induction generators,” *Renewable Energy*, vol. 31, no. 7, pp. 935 - 951, June 2006.
- [31] Kristoffersen J. R., “The Horns Rev wind farm and the operational experience with the

wind farm main controller,” in *Offshore Wind in Copenhagen*, 2005.

- [32] Rohrig K., et. al., “Wind power plant capabilities – Operate wind farms like conventional power plants,” in *European Wind Energy Conference*, Marseille, France, 2009.
- [33] BiHui L, Hong S, Yong T, Hongyun Z, Feng S, and Dongfu L, “Study on the frequency control method and AGC model of wind power integration based on the full dynamic process simulation program,” in *International Conference on Power System Automation and Protection (APAP), IEEE*, Beijing, 2011.
- [34] Ummels BC, Gibescu M, Kling WL and Paap GC, “Performance of Automatic Generation Control Mechanisms with Large-Scale Wind Power,” in *Nordic Wind Power Conference*, 2007.
- [35] Robles R.V., Sumper A., Suwannarat A., Birgitte B.J., Ramirez R., Gomis R., Sudria A., “On wind power integration into electrical power system: Spain vs. Denmark,” in *Electrical Power Quality and Utilization, EPQU 2007*, Barcelona, 2007.
- [36] REserviceS, “Grid support services by wind and solar PV: Synthesis report of the REserviceS project (WP7),” REserviceS, 2014.
- [37] REserviceS, “Ancillary services from wind and solar PV at transmission level - evaluation and conclusions of case studies (D5.5),” REserviceS, 2014.
- [38] Sørensen P., Norheim I., Meibom P. and Uhlen K., “Simulations of wind power integration with complementary power system planning tools,” *Electric Power Systems Research*, p. 1069–1079, 2007.
- [39] Eriksen P.B.; Orths AG.; Akhmatov V., “Integrating dispersed generation into the Danish power system - present situation and future prospects,” in *IEEE Power Engineering Society General Meeting*, 2006.
- [40] Skødt T, “Electricity interconnections,” Energinet.dk, 20 February 2014. [Online]. Available: <https://www.energinet.dk/EN/ANLAEG-OG-PROJEKTER/Generelt-om-elanlaeg/Sider/Elforbindelser-til-udlandet.aspx>. [Accessed 03 10 2014].
- [41] Birkebæk, J.M., “Great Belt - Connection. Market implications,” 01 12 2009. [Online]. Available:

- <http://www.energinet.dk/SiteCollectionDocuments/Engelske%20dokumenter/Om%20os/Great%20Belt%20Connection.pdf>. [Accessed 03 10 2014].
- [42] Energinet.dk, “Limitations to the Norwegian electricity grid affects the Skagerrak 4 interconnection,” Energinet.dk, 31 May 2013. [Online]. Available: www.energinet.dk/EN/EI/Nyheder/Sider/Begraensninger-i-norsk-elnet-paavirker-Skagerrak-4-forbindelsen.aspx. [Accessed 03 10 2014].
- [43] Energinet.dk, “The electrical interconnections to Norway and Germany to be expanded,” 17 June 2008. [Online]. Available: www.energinet.dk/EN/EI/Nyheder/Sider/The.electrical.interconnections.to.Norway.and.Germany.to.be.expanded.aspx. [Accessed 03 October 2014].
- [44] Energinet.dk, “EU grants EUR 86,5m to COBRA cable,” Energinet.dk, 16 July 2012. [Online]. Available: www.energinet.dk/EN/ANLAEG-OG-PROJEKTER/Nyheder/Sider/EU-grants-EUR-86,5-m-to-COBRAcable.aspx. [Accessed October 2014].
- [45] European Commission, “Green Public Procurement Electricity Technical Background Report,” The European Commission, Brussels, 2011.
- [46] Odgaard, O., “Denmark a leading player in Combined Heat and Power,” Danish Energy Agency, [Online]. Available: <http://www.ens.dk/sites/ens.dk/files/politik/Kinasamarbejdet/Materialer/Faktaark/chp.pdf>. [Accessed 03 October 2014].
- [47] Odgaard O., “Large and small scale district heating plants,” Danish Energy Agency, [Online]. Available: <http://www.ens.dk/en/supply/heat-supply-denmark/large-small-scale-district-heating-plants>. [Accessed 03 October 2014].
- [48] “Denmark/Powerplants,” [Online]. Available: <http://enipedia.tudelft.nl/wiki/Denmark/Powerplants>.
- [49] Dong Energy, “Central Power Stations,” Dong Energy, [Online]. Available: http://www.dongenergy.com/en/business%20activities/generation/activities/central_power_stations/pages/default.aspx. [Accessed 03 October 2014].
- [50] Andersen, A.N.; Ritter, P.; Lange, B.; Toke, D.; Fragaki, A.; Madina, C.; Wojdyga, K.; Terno, O., “CHP-plants with big thermal stores balancing fluctuating productions from

Wind turbines,” DESIRE ProjectWP 4, Aalborg, 2007.

- [51] Sorknæs P.; Mæng H.; Weiss T.; Andersen A.N., “Overview of the Danish Power System and RES integration,” European project stoRE, July 2013.
- [52] Sorensen, P.; Cutululis, N.A., “Wind farms' spatial distribution effect on power system reserves requirements,” *Industrial Electronics (ISIE), 2010 IEEE International Symposium*, pp. 2505-2510, July 2010.
- [53] Jensen, T.K., “Offshore investments in Denmark,” Danish Energy Agency, [Online]. Available: http://www.ens.dk/sites/ens.dk/files/supply/renewable-energy/wind-power/offshore-wind-power/new-nearshore-wind-tenders/nearshore_tender_ewea_barcelona.pdf. [Accessed 03 October 2014].
- [54] NERC, “Balancing and Frequency control - A technical document prepared by the NERC resources subcommittee,” NERC, January 2011.
- [55] Rebours, Y.G.; Kirschen, D.S.; Trotignon, M.; Rossignol, S., “A Survey of Frequency and Voltage Control Ancillary Services—Part I: Technical Features,” *IEEE Transactions on Power Systems*, vol. 22, no. 1, pp. 350 - 357, February 2007.
- [56] ENTSO-E, “Operational reserves ad-hoc team report,” ENTSO-E, 2012.
- [57] Energinet.dk, “Amendment to Energinet.dk’s ancillary services strategy,” Energinet.dk, 2013.
- [58] UCTE, “Policy 1: Load-Frequency Control,” ENTSO-E, 2009.
- [59] Energinet.dk, “Energinet.dk’s ancillary services strategy,” Energinet.dk, 2011.
- [60] Gleditsch M., “Balancing of Offshore Wind Power in Mid-Norway,” Norwegian University of Science and Technology (NTNU), Auhust 2009.
- [61] NordREG, “Harmonising the balancing market Issues to be considered,” Nordic Energy regulator, July 2010.
- [62] Hansen AB, Orths A, Falk K, Detlefsen NK, “Danish Fossil Independent Energy System 2050- From Strategic Investigations to Intra-Hour Simulation of Balancing Issues,” in *10th*

International Workshop on Large-Scale Integration of Wind Power into Power Systems, Aarhus, 2011.

- [63] Prabha, K., *Power System Stability and Control*, McGraw-Hill, 1994.
- [64] ENTSO-E, “Continental Europe Operation Handbook – p1: LOAD-FREQUENCY CONTROL AND PERFORMANCE,” [Online]. Available: <https://www.entsoe.eu/publications/system-operations-reports/operation-handbook/>. [Accessed September 2013].
- [65] I.C. Report, “Dynamic Models for Steam and Hydro Turbines in Power System Studies,” *IEEE Transactions on Power Apparatus and Systems*, Vols. PAS-92, no. 6, pp. 1904-1915, November 1973.
- [66] IEEE Committee Report, “Dynamic models for fossil fueled steam units in power system studies,” *IEEE Transaction on Power Systems*, vol. 6, no. 2, pp. 753-761, May 1991.
- [67] CIGRE Task Force 25 of Advisory Group 02 of Study Committee C4, “Modeling of Gas Turbines and Steam Turbines in Combined Cycle Power Plants,” CIGRE, 2003.
- [68] Flynn D., “Advances in power plant technology,” in *Thermal Power Plant Simulation and Control*, Stevenage, UK, The institute of Electrical Engineers, 2003, pp. 5-6.
- [69] IEC 61400-27 Committee Draft, Wind Turbines Part 27-1, “Electrical simulation models for wind power generation Wind turbines,” IEC Std. committee Draft (CD) 88/424/CD, 2012.
- [70] Twenties project, “Economic impact analysis of the demonstrations in task-forces TF1 and TF3 - Deliverable: D15.1,” Twenties transmitting wind, 2013.

Appendix: Models parameters

Parameters of all models are presented in this Appendix as shown in the following tables. Parameters of the AGC system are shown in Table 10. Parameters of a WPP are shown in Table 11. Parameters of a CHP unit model are shown in Table 12. Parameters of the DCHP unit model are shown in Table 13.

Table 10: Parameters of AGC controller

Variable	Description	Parameter
T_{AGC}	Integration time constant of AGC	55 sec
K_{AGC}	Proportional gain of AGC	0.2
F_{REF}	Reference frequency	50 Hz
B	Bias factor of the control area	2387 MW/Hz – Eastern Denmark
		3046 MW/Hz – Western Denmark
$\Delta P_{CHP} (\max)$	Maximum secondary dispatch from CHP	+90 MW
$\Delta P_{CHP} (\min)$	Minimum secondary dispatch from CHP	-90 MW

Table 11: Parameters of an aggregated WPP model

	Variable	Description	Parameter
WPP active power controller	T_{PI}	Integration time constant	0.01 sec
	K_{PI}	Proportional gain	0.01
	T_{filter}	Filtering Time Constant	0.2 sec
WT active power controller	T_{PI}	Integration time constant	0.001 sec
	K_{PI}	Proportional gain	1
	T_{filter}	Filtering Time Constant	0.1 sec
	I_{p_max}	Maximum reference current	1.3
	I_{p_min}	Minimum reference current	-1.3
Static Generator	T_g	Time constant for first order lag	0.005 sec
	T_{slope}	Time constant for slope limiter	0.001 sec
Governor	R_{WPP}	WPP droop setting	4%
	T_{filter}	Filtering time constant	0.1 sec

Table 12: Parameters of an aggregated CHP model

Steam turbine	K1	Very high pressure turbine power fraction	0.22 %
	K2	Very high pressure turbine power fraction	0 %
	K3	High pressure turbine power fraction	0 %
	K4	High pressure turbine power fraction	0.22 %
	K5	Intermediate pressure turbine power fraction	0.14 %
	K6	Intermediate pressure turbine power fraction	0.14 %
	K7	Low pressure turbine power fraction	0.14 %
	K8	Low pressure turbine power fraction	0.14 %
	T1	High pressure turbine bowl time constant	0.4 sec
	T2	Re-heater time constant	11 sec
	T3	Crossover time constant	11 sec
	T4	Double Re-heater time constant	0.5 sec
	Boiler model	Tb1	1 st Boiler time constant
Tb2		2 nd Boiler time constant	30 sec
Tb3		3 rd Boiler time constant	40 sec
Boiler Turbine control	Ramp rate	Steam rate limiter	30 MW/min
Governor	R	Drop setting	4%
	T _{filter}	Filter time constant	0.1 sec
	D _{band}	Dead band	0 Hz
Synchronous generator	V	Nominal voltage	400 kV
	H	Inertia	10 sec

Table 13: Parameters of an aggregated DCHP model

Parameters	Description	Variables	
Governor	ω_{ref}	Reference frequency	1 pu
	T_f	Pre filter time constant	0.05 sec
	D_{band}	Dead Band	0 Hz
	R	Governor droop settings	4 %
Turbine	$F_{R_{max}}$	maximum power level for frequency level	1 pu
	$F_{R_{min}}$	minimum power level for frequency level	0.05 pu
	Rate Limiter	Power ramp rate	0.014 pu/sec
	CFM	Base load function	1 sec
	CEV	Environmental burner capacity	0.15 sec
	CSEV	Sequential Environmental burner capacity	0.25 sec
	CVGV	Variable inlet guide vane position compressor capacity	0.60 sec
	TEV	Environmental burner capacity time constant	5.00 sec
	TSEV	Sequential Environmental burner capacity time constant	5.00 sec
	ω	Un-damped natural frequency	0.22 rad/sec
	ζ	Damping ratio of the compressor	0.8 pu
	P_{max}	Maximum power	1.1 pu
	P_{min}	Minimum power	0.05 pu
	L_{max}	Maximum load set point	1.0 pu
L_{min}	Minimum load set point	0.05 pu	
Synchronous Generator	V	Nominal voltage	400 kV
	H	Inertia	8.6 sec

Publications

P 1: Basit A.; Hansen A. D.; Altin M.; Sørensen P.; Gamst M.: 'Wind power integration into the automatic generation control of power systems with large-scale wind power', The Journal of Engineering, 1 (1), DOI: 10.1049/joe.2014.0222, IET Digital Library, <http://digital-library.theiet.org/content/journals/10.1049/joe.2014.0222>

Wind power integration into the automatic generation control of power systems with large-scale wind power

Abdul Basit^{1,2}, Anca Daniela Hansen¹, Mufit Altin¹, Poul Sørensen¹, Mette Gamst³

¹Department of Wind Energy, Technical University of Denmark, Frederiksborgvej 399, Building 125, 4000 Roskilde, Denmark

²Sino-Danish Centre for Education and Research, Niels.JensensVej 2, 8000 Aarhus, Denmark

³Energinet.dk, Tonnekjærvej 65, 7000 Fredericia, Denmark

E-mail: abdl@dtu.dk

Published in *The Journal of Engineering*; Received on 13th August 2014; Accepted on 20th August 2014

Abstract: Transmission system operators have an increased interest in the active participation of wind power plants (WPP) in the power balance control of power systems with large wind power penetration. The emphasis in this study is on the integration of WPPs into the automatic generation control (AGC) of the power system. The present paper proposes a coordinated control strategy for the AGC between combined heat and power plants (CHPs) and WPPs to enhance the security and the reliability of a power system operation in the case of a large wind power penetration. The proposed strategy, described and exemplified for the future Danish power system, takes the hour-ahead regulating power plan for generation and power exchange with neighbouring power systems into account. The performance of the proposed strategy for coordinated secondary control is assessed and discussed by means of simulations for different possible future scenarios, when wind power production in the power system is high and conventional production from CHPs is at a minimum level. The investigation results of the proposed control strategy have shown that the WPPs can actively help the AGC, and reduce the real-time power imbalance in the power system, by down regulating their production when CHPs are unable to provide the required response.

1 Introduction

The active power balance control is becoming more significant for transmission system operators (TSOs) over the years because of the dramatic increase of wind power penetration into the power systems. Nowadays, power systems are evolving from classical systems operated and controlled by the conventional power plants into power systems based on wind power to a larger extent. This means, that TSOs must be able to cope with new challenges in power system operation, raising concerns about dynamic security and reliability. In an interconnected power system, the TSO should maintain the system frequency of each area within specified limits and the tie line power flow at its plan. Traditionally, conventional power plants have the task of maintaining the active power balance and are capable of meeting the TSO guidelines. Their possible future replacement by wind power plants (WPPs) of similar size increases the risk of system failures, unless the TSOs revise and set new requirements for WPPs, that is, to participate in active power balance control.

Active power control from WPPs is a challenging technical issue, which has initiated an intensification of this research area in academia and industry. Several studies regarding active power control from WPPs have been performed in the past few years. For example, a comprehensive state-of-the-art review, regarding the frequency regulation and spinning reserves from variable speed wind turbines, is conducted in [1, 2]. Results from [3] show that increasing wind power integration alters the frequency behaviour and therefore TSOs must develop solutions to meet the challenges. A Dutch case study has been developed in [4] to assess the automatic generation control (AGC) performance in the presence of large-scale wind power and found that additional reserves are required for keeping the area control error (ACE) at the same level. Recent Chinese studies [5] have led to the conclusion that the fluctuation from WPPs can be controlled via conventional generators. In the USA, intensive work on the development of wind turbine control system to vary a turbine's active power output as demanded by the TSO has been conducted and described in detail in [6]. According to [7], the WPPs can participate in frequency regulation services with

energy storage devices such as super capacitor banks, while [8] analyses the benefits of active power regulation from WPPs. However, the increasing wind power integration may replace or dominate the electricity generation from conventional power plants in future power systems and it may require active participation from the WPPs in the active power balance control on the power system level. Further studies in this context, for example, WPPs integration into the AGC system, are necessary to enhance operational security of future power system with large-scale wind power integration.

The objective of this study is to investigate how WPPs can actively participate in the secondary frequency control. This study proposes a coordinated control strategy for the AGC between the combined heat and power plants (CHPs) and WPPs in order to improve the active power balance in the power system with minimum secondary dispatch cost. The described control strategy regulates the active power production from CHPs and WPPs, depending on operating reserves, dispatch limit and the generating cost. The WPPs can only provide down regulation services if they are not operating in delta mode, where wind power is kept as reserve. The proposed strategy is developed and exemplified considering the Danish power system, as this is characterised by the highest wind power penetration level in Europe and aims to further increase the wind power capacity to cover almost 50% of the total energy requirement by 2020 [9].

This study is structured as follows. A brief description of the developed dynamic power system model implemented in Power Factory is provided first. The active power balance control, taking into account the hour-ahead (HA) regulating power plan for generation and power exchange with neighbouring power systems and real-time balance control, is then described. The implementation of the proposed control strategy for the integration of wind power into the AGC of the power system follows next. The high wind penetration scenario for the Danish power system in year 2020 is used to assess the performance of the presented coordinated AGC strategy between CHP and WPP through a set of simulations with the developed power system model. Finally, conclusive remarks are given in the final section.

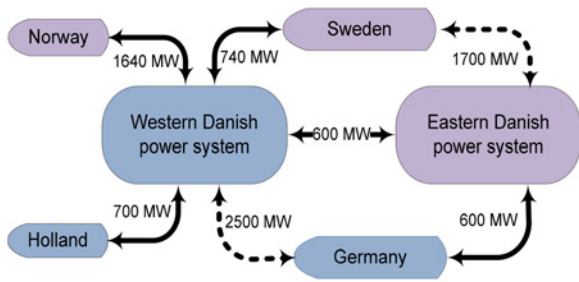

Fig. 1 Interconnection capacities for the year 2020 [10]

2 Dynamic power system modelling

As previously mentioned, the Danish power system is used to validate the performance of the proposed coordinated control strategy for AGC. The Danish power system is electrically separated into two synchronous areas, that is, eastern and western Danish power systems, and synchronised with the strong Nordic and Continental European (CE) synchronous power systems, respectively. Fig. 1 shows the interconnection capacities of the Danish power system with its neighbouring powers as planned for the year 2020 [10], where AC interconnections are presented as dotted line and the DC interconnections as solid line.

The electrical power generation in Denmark is a combination of conventional and renewable generation sources. The conventional power generation is typically from CHPs and de-centralised CHPs (DCHPs), whereas renewable generation is usually from WPPs. Studying the coordinated AGC strategy in the Danish power system requires a detailed representation of the power system that includes conventional power plants, WPPs and the interconnection with neighbouring power systems, as shown in Fig. 2. The aggregated models developed for this paper reduce the computation effort but still contain the dynamic features relevant for the present investigation, without missing relevant behaviours of the generating systems.

The developed power system model and the description of the HA planned and real-time inputs, provided by the power balancing model and the AGC, respectively, are based on the description in [11–15]. The power balancing model, called simulation power balancing model (SimBa), provides the HA regulating power plans for a balanced power system based on the input time series from day-ahead (DA) spot market and HA forecast of wind power.

2.1 Conventional power plants (CHPs and DCHPs)

Aggregated models for CHP and DCHP are developed based on the studies described in [12–14]. These models contain both the primary and secondary control capabilities and reflect the relevant dynamic features for long-term dynamic simulation studies. The response time associated with a CHP is in the order of minutes

and is the dominant characteristic for power system studies. In the proposed strategy, the reference power for CHP and DCHP is calculated based on the HA plan from power balancing model ($P_{\text{plan_CHP}}$ and $P_{\text{plan_DCHP}}$) and the power correction from the AGC (ΔP_{CHP}).

2.2 Wind power plants

At power system level, the aggregated performance of a large number of wind turbines is in focus rather than the detailed performance of individual wind turbines. An aggregated WPP model, based on the IEC61400-27-1 recommendations [15] and further simplified for the secondary active power control purpose of the present paper, has been implemented.

As illustrated in Fig. 3, the aggregated wind turbine model includes an active power controller and a generator system. The generator system simulates the wind turbine response. The wind turbine model provides the relevant dynamic response of WPP with respect to active power control capabilities, using as inputs the measured power at point of common coupling (PCC) and the reference power ($P_{\text{ref_WPP}}$) from the WPP active power controller. The $P_{\text{ref_WPP}}$ to the wind turbine model is calculated inside the WPP active power controller based on two input signals. One input signal is conducted based on the primary response from the WPP (ΔP_c), whereas the other (P_{ref}) is determined based on the required secondary response (ΔP_{WPP}) from the AGC and the available wind power signal ($P_{\text{WPP_avail}}$) from the power balancing model. Besides the two mentioned inputs signals, the WPP active power controller is also using information on the measured power at PCC ($P_{\text{meas_PCC}}$) in the decision of the $P_{\text{ref_WPP}}$.

3 Active power balance control

The TSOs are obliged to securely operate the power system in transporting the generated electricity to the end consumers and maintain the power balance in the power system. This electricity is traded in the electricity markets by the balance responsible companies, who can produce, consume or retail. The balance responsible companies trade for each operating period during the next day in the DA market. The dispatch bids are selected with foremost intent of preserving system integrity and to minimise the production cost. The balance responsible companies also trade on the intraday (HA) market before the actual operation period, taking into account the updated wind power forecasts or unavailability of power plants. The following sections explain first the power balancing model with the generation of HA regulating power plan in a time scale of 5 min for the power plants and power exchange with neighbouring power systems and then the real-time power balance control in the power system.

3.1 HA power balance control

The TSOs use and combine information from different programmes to ensure the power balance in the power system. These

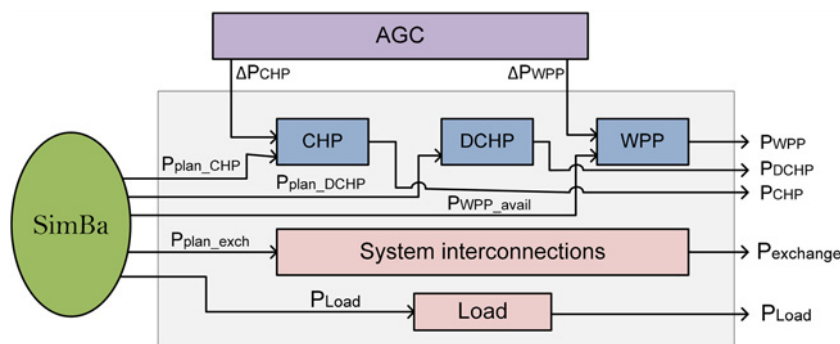

Fig. 2 Inputs–outputs overview of the dynamic power system model

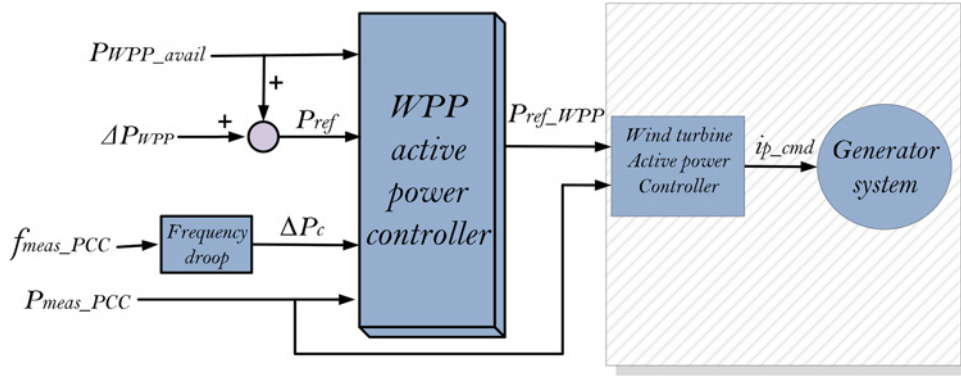

Fig. 3 Aggregated WPP model [15]

programmes provide information regarding wind power forecast and load demand, and also simulate the regulating power plan for balanced power system. SimBa, for instance, is the kind of programme used to simulate HA regulating power plan in Denmark. SimBa generates HA plans for the intra-hour balance with 5 min periods based on input time series from DA market model and HA forecast of wind power. The DA time series (P_{plan_DA}) are provided by wind power integration in liberalised electricity market (WILMAR), whereas the correlated wind power fluctuations (CorWind) model provides the HA forecast of wind power (P_{WPP_HA}), as shown in Fig. 4. The CorWind model also provides the DA forecast of wind power (P_{WPP_DA}) and the available wind power (P_{WPP_avail}).

SimBa models the power system taking into account the current grid regulations and the electricity market rules. SimBa uses inputs from WILMAR that include hourly values for energy production, load and the power exchange between interconnected areas and HA wind power forecasts from CorWind. Based on these inputs, SimBa balances the power system and provides HA 5 min period plan for generating plants and power exchange with neighbouring power systems, that is, P_{plan_HA} .

3.2 Real-time power balance control

The active power reserves are always needed to keep the power system in balance. In a highly wind power integrated power system, the reserves from fast conventional generating units increase the system reliability and also ensure the power supply security. According to European Network of Transmission System Operators for Electricity (ENTSO-E), the type of reserves needed to keep the power system in balance can be classified as

frequency containment reserves (FCRs), frequency restoration reserves (FRRs) and replacement reserves (RRs) [16]. FCR are activated automatically within 30 s to constantly control frequency deviations and maintain the power balance in the whole synchronously interconnected system. FRR maintains the active power balance in the power system, and the power exchange with neighbouring power system at its schedule, and are typically activated (manually or automatically) within 15 min. RR restores the FRR back to the required level and responds from several minutes up to hours. The total volume of FCR in CE and Nordic region is ± 3000 and ± 600 MW, respectively [16]. In this paper, power imbalance is controlled through FCR and automatic FRR. Conventional power plants and WPPs provide the FCR, whereas FRR is activated from CHPs and WPPs through AGC.

In Denmark, the active power balance is controlled through activation of regulating bids from the Nordic Operational Information System (NOIS) list in the TSO's control room and also through AGC, with a reserved capacity of ± 90 MW acting on the border of western Denmark with Germany. However, for the present investigation, it is assumed that the power imbalance is controlled only through AGC. As the focus in this study is on integrating WPPs into the generation control, an AGC for eastern and western Danish power systems is implemented together with WPPs to investigate the AGC action in the Danish power system as in 2020 with an active integrated role of WPPs in the AGC.

4 Coordinated AGC between CHP and WPP

A coordinated control methodology for AGC, where both CHP and WPP are participating actively, is presented in this paper. The following sections explain first the implementation of an AGC and

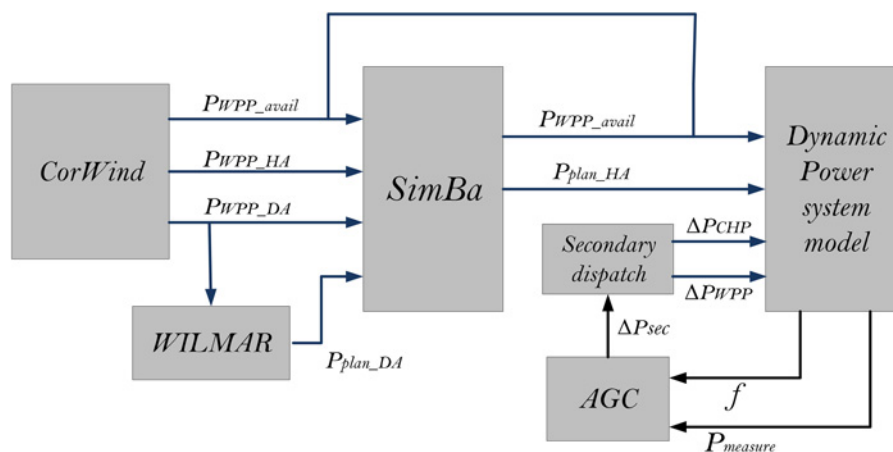

Fig. 4 Overview of the signals between CorWind, WILMAR, SimBa, the dynamic power system model and the AGC

then the coordinated control dispatch strategy between CHP and WPP.

4.1 Automatic generation control

The AGC is used to routinely balance the power system and makes the power system operation more reliable [17]. In the CE, the AGC is used to maintain the tie line interchanges at their plan level [18], as in the western Danish power system.

The AGC developed and implemented in this investigation, for the eastern and western Danish power system, is sketched in Fig. 5. In each part of the Danish power system, AGC measures the frequency deviation (Δf) from its nominal level and the possible power mismatch (ΔP) between generations (CHP, DCHP and WPP) and power exchange with neighbouring power systems and system load. The sum of ΔP with the product of Δf and system frequency bias factor (B) is called the ‘area control error’ (P_{ACE}). B is determined from the droop characteristics of all generating units taking part in the primary response [20]. Equations (1) and (2) show the P_{ACE} and ΔP , respectively

$$P_{ACE} = \Delta P + (\Delta f \times B) \quad (1)$$

$$\Delta P = P_{Load} + P_{exchange} - P_G \quad (2)$$

As indicated in Fig. 5, the P_{ACE} is processed by a central controller, usually a proportional–integral (PI), which calculates the required change in production (ΔP_{sec}) for the power plants to bring the P_{ACE} to zero, that is

$$\Delta P_{sec} = K \times P_{ACE} + \frac{1}{T} \int P_{ACE} \quad (3)$$

where ‘ K ’ and ‘ T ’ are the gain and integration time constants, respectively, and are adjusted based on the recommendation from [21] for the CE power system. The ΔP_{sec} is then distributed using the ‘dispatch strategy’ block among the actively participating generators, namely CHP and WPP assumed in this paper. This dispatch thus decides the change in reference power for the generating units CHP and WPP, that is, ΔP_{CHP} and ΔP_{WPP} , by using as input signals ΔP_{sec} , CHP generation (P_{CHP}), WPP generation (P_{WPP}) and the available wind power (P_{WPP_avail}). Moreover, the dispatch strategy also takes into account the power generation limits (minimum and maximum) from the participating generating units.

4.2 Dispatch strategy between CHP and WPP

Traditionally conventional power plants provide the secondary frequency control in real-time operation. However, the increasing wind power integration may require active participation from WPPs in secondary frequency control in future power systems along with conventional power plants, as some conventional power plants might be replaced by WPPs. Coordinated AGC with dispatch between conventional power plants and WPPs is therefore

of high priority for operational security and stability. This can be achieved by taking into account the generation and available reserves capacity from all participating generating plants for the secondary power control.

In the present paper, the secondary dispatch between CHP and WPP is performed based on cost minimisation. The following set of equations decides the positive and negative secondary dispatches for the WPP and CHP, (4)–(9) (positive) and (10)–(14) (negative)

$$\text{minimise } C = C_{P_{WPP}} \Delta P_{WPP} + C_{P_{CHP}} \Delta P_{CHP} \quad (4)$$

∴ positive dispatch cost

Subject to

$$\Delta P \geq 0 \quad (5)$$

$$\Delta P_{CHP} \leq \Delta P_{CHP_UpLim} \quad (6)$$

$$P_{CHP} \leq P_{CHP_max} \quad (7)$$

$$\Delta P_{WPP} \leq P_{WPP_avail} - P_{WPP} \quad (8)$$

$$P_{WPP} \leq P_{WPP_avail} \quad (9)$$

$$\text{maximise } C = C_{P_{WPP}} \Delta P_{WPP} + C_{P_{CHP}} \Delta P_{CHP} \quad (10)$$

∴ negative dispatch cost

Subject to

$$\Delta P < 0 \quad (11)$$

$$\Delta P_{CHP} \geq \Delta P_{CHP_LowLim} \quad (12)$$

$$P_{CHP} \geq P_{CHP_min} \quad (13)$$

$$P_{WPP} \leq P_{WPP_min} \quad (14)$$

where $C_{P_{WPP}}$ is the power generation cost from WPP, $C_{P_{CHP}}$ is the power generation cost from CHP, P_{WPP_min} is the minimum generation level of WPP, P_{CHP_min} is the minimum generation of CHP and P_{CHP_max} is the maximum generation of CHP.

As mentioned in Section 3, the WPP will generate the available wind power ($P_{WPP} = P_{WPP_avail}$). Therefore, during positive secondary dispatch (4), only CHP will participate. However, during negative secondary dispatch, as $C_{P_{WPP}} \ll C_{P_{CHP}}$, the wind power is down regulated only when CHP is unable to follow AGC command. Otherwise, the WPP will generate its maximum available power. The assumption is useful for the situation when WPP is generating highly and the conventional power plants are running on their lower level. In this paper, the dispatch for CHP (ΔP_{CHP}) is limited to ± 90 MW, as is the case for the AGC acting on the border of western Denmark with Germany, and WPP can reach their minimum generation level and available wind power.

The secondary dispatch in this paper, based on the above equations, will be as follows: the WPP is down regulated only when the output of AGC is negative, that is, $\Delta P_{sec} < 0$, whereas the

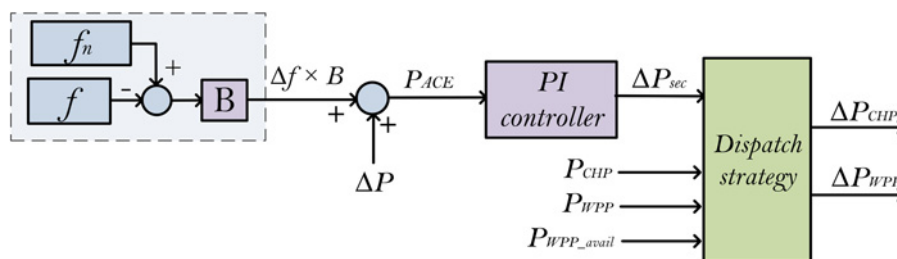

Fig. 5 AGC and dispatch strategy model – [19]

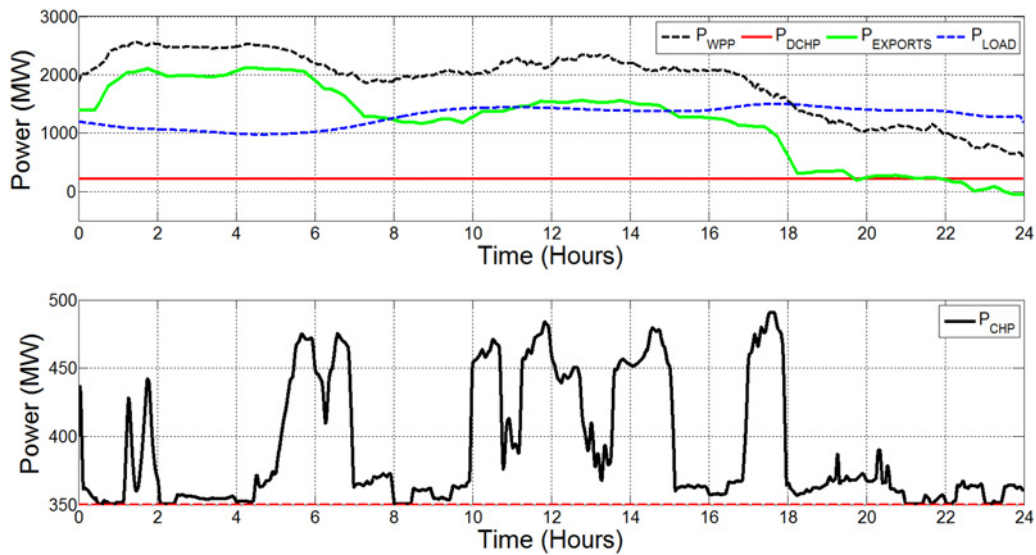

Fig. 6 Generation, load and power exports – eastern Danish power system

CHP provides secondary response for positive or negative value of ΔP_{sec} . For down regulation, the WPP will receive reference power signal only when CHP generation touches the lower generation limit (P_{CHP_min}) or ΔP_{sec} reaches to ΔP_{CHP_LowLim} , that is, -90 MW. However, in case of up regulation, that is, $\Delta P_{sec} > 0$, only the CHP provides the secondary support, as the WPP is already generating the available wind power.

5 Simulations and results

A set of simulations has been carried out to illustrate the dynamic performance of the proposed and implemented active power balanced control strategy, where wind power is directly integrated in the AGC control. The simulations are performed using the time series for generation, load and power exchange corresponding to one particular day of the year 2020 with high wind power. These time series are generated by the HA power balancing model (SimBa) for the Danish power system based on the real data from the year 2009. In this paper, the power exchange is kept at its planned level, whereas the reference powers of CHP and WPP are altered from the HA plan within the operating hour, as directed

by the AGC. The power generated within the operating hour by WPP and CHP in the eastern and western Danish power systems is shown in Figs. 6 and 7, respectively. These figures also show the load demand and the planned power exports with neighbouring power systems. The power exports with neighbouring power systems are calculated by subtracting the total import power from the total export power within their respective power systems.

From Figs. 6 and 7 it can be seen that the WPP is generating higher than the CHP. The online capacity of CHP in eastern and western Danish power systems on the particular day is 1754 and 1944 MW, respectively. CHP is frequently operating near the minimum operating point, that is, 20% of the online capacity, marked as dotted line in these figures. The higher production from WPP also permits positive power exports with neighbouring power systems.

Power mismatch between generation and load appears when the actual wind power generated within the operating hour differs from the HA forecast or when other unpredicted events take place in the power system, like generator failures or line loss. The generating unit responds to the power imbalance by releasing FRR through the AGC. Fig. 8 shows the power imbalance in the eastern and

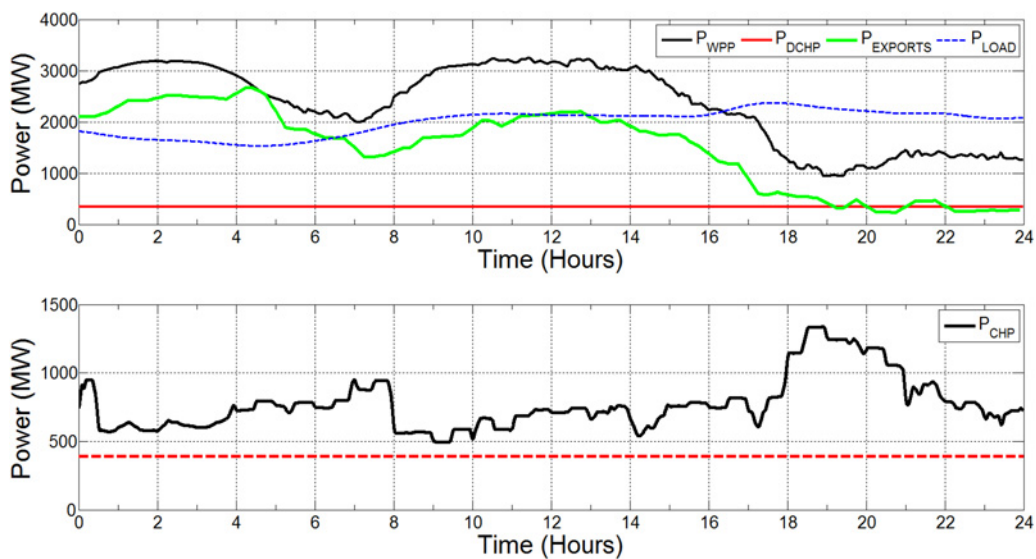

Fig. 7 Generation, load and power exports – western Danish power system

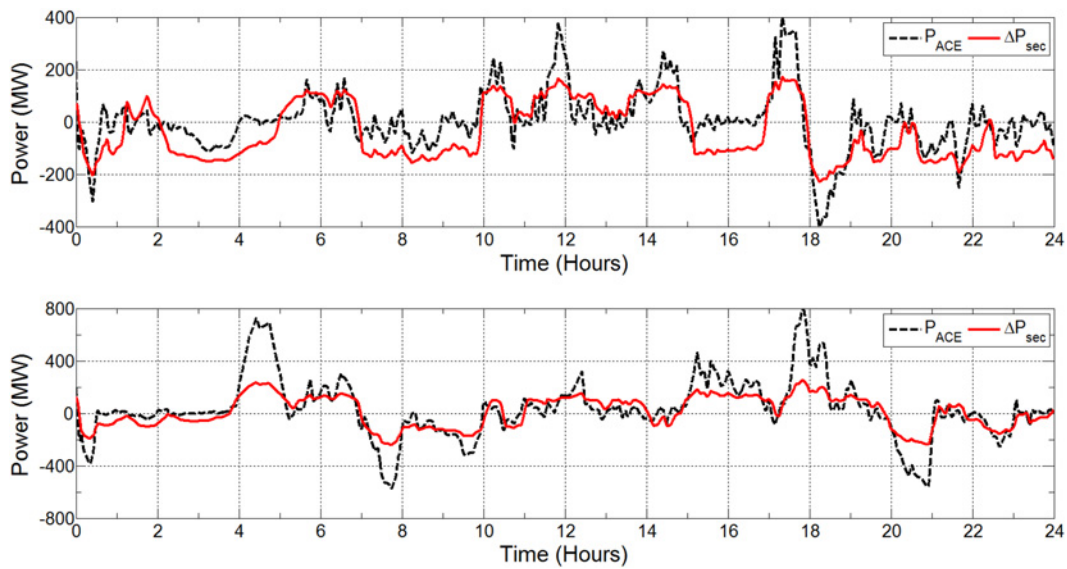

Fig. 8 P_{ACE} and ΔP_{sec} – top: eastern Danish power system; bottom: western Danish power system

western Danish power systems, reflected by the ACE signal, that is, P_{ACE} . As depicted in Fig. 5, the P_{ACE} is the input signal used in the PI controller of the AGC to decide the necessary secondary response (ΔP_{sec}) from the generating units to compensate for the power imbalance. As shown in Fig. 8, the ΔP_{sec} lags behind P_{ACE} because of the delays in the AGC system and the delays associated with the power plants response. These delays are because of the ramp in the reference power (i.e. 30 MW/min considered in this paper) and also because of the slow boiler response of CHP units (i.e. the boiler needs 5–6 min to modify its output pressure when demanded).

The new reference power signals for CHP and WPP are then determined by the dispatch strategy. The change in reference power signals for CHP and WPP in the eastern and western Danish power systems, calculated through the proposed dispatch strategy, is shown in Fig. 9. Note that WPP only participates in the down regulating process, whereas CHP contributes to both up and down regulating processes. The down regulating secondary dispatch to the WPP (ΔP_{WPP}) is activated only when CHP is unable to provide the required response. This simulation shows the strength of

the proposed coordinated AGC between WPP and CHP, namely that when the CHP dispatch (ΔP_{CHP}) touches the lower limit (–90 MW) or they are operating at their lower generation limit (20% of the online capacity), this being quite frequent, the WPP can actively help the AGC, and reduce the real-time power imbalance in the power system, by down regulating their power production. It is worth mentioning that on the particular day considered in the present investigation, out of the available wind energy in eastern and western Danish power systems of 46.6 and 56.93 GWh, respectively, 1.06 GWh and 320 MWh are spilled out in the down regulation of the WPP to compensate for the power imbalance. The amount of energy lost for maintaining power balance is thus 2.2 and 0.56% of the available wind energy in the hugely wind power integrated eastern and western Danish power systems, respectively, when CHP is not able to provide the required response. This shows that active participation of WPP in AGC is an attractive solution for future power systems with large scale of wind power.

Fig. 10 compares the initial power imbalance in the eastern and western Danish power systems with the power imbalance when secondary dispatch is controlled with AGC controlled CHP and AGC

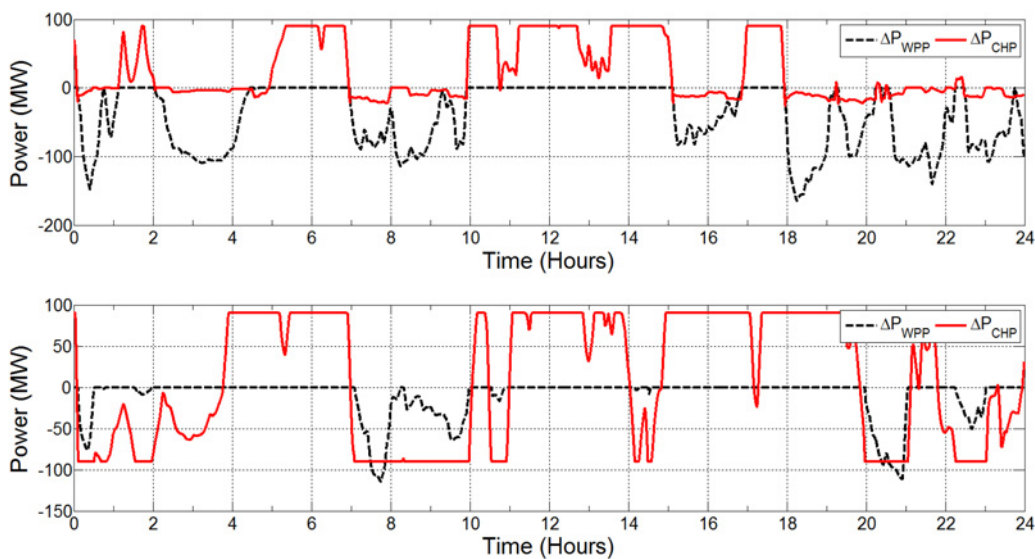

Fig. 9 ΔP_{CHP} and ΔP_{WPP} – top: eastern Danish power system; bottom: western Danish power system

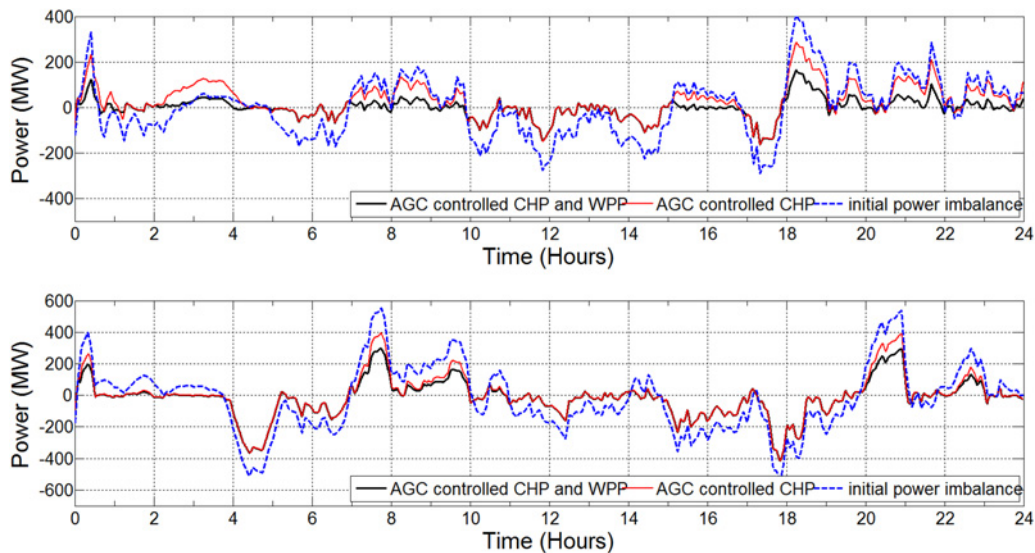

Fig. 10 Power imbalance – top: eastern Danish power system; bottom: western Danish power system

controlled CHP and WPP. It can be seen that without WPP integration, the power imbalance is larger in the case of generation excess than in the case with WPP, as CHP is frequently operating at the minimum level or ΔP_{CHP} reaching to its lower limit. The simulations show that the integration and active participation of WPP in the AGC system reduces the real-time power imbalances and makes power system operation more reliable.

6 Conclusion

This study proposes and presents a novel and practical approach for integration of wind power into the AGC of power systems to compensate the power imbalances between demand and generation in real time, provoked by wind power forecast errors. It is based on a coordinated control strategy between CHPs and WPPs. The Danish power system, with high wind penetration corresponding to year 2020 scenarios, is used as a case study in the verification of the proposed method. The new control methodology for the AGC system with WPPs integrated is using input time series from a power balancing model on power generation, power demand and power exchange with the neighbouring systems. Study with high wind penetration scenarios, corresponding to one particular day with high wind speed in 2020, is performed and presented in order to illustrate how power imbalances between demand and generation can be compensated by regulating the active power production from conventional and WPPs.

The present investigation shows that the active integration of wind power into the dispatch of the AGC is an attractive active power balancing control solution for power systems with large-scale wind power penetration. The strength of the solution is of high relevance, particularly in situations when wind power is contributing with large portion of the total electricity production and when the conventional power plants are operating at the minimum level and cannot be further down regulated in case of generation excess. The down regulation of the wind power reduces the power imbalance in real-time operation and because of its fast ramp rates can also provide quick ACE compliance. Furthermore, a good forecasting of wind speed and load demand and an increased automatic generation controller capacity, are always important for a secure and reliable power system operation of a large-scale wind power integrated power system. Further research can also investigate the programmed control of regulating bids in real time to enhance the secure and reliable power system operation for highly integrated wind power scenarios.

7 Acknowledgment

This paper is a part of Ph.D. project funded by the Sino-Danish centre for education and research (SDC).

8 References

- [1] Gao W., Wu Z., Wang J., Gu S.: 'A review of inertia and frequency control technologies for variable speed wind turbines'. 25th Chinese Control and Decision Conf. (CCDC), Guiyang, 2013
- [2] Sun Y.Z., Zhang Z.S., Li G.J., Lin J.: 'Review on frequency control of power systems with wind power penetration'. Int. Conf. on Power System Technology (POWERCON), IEEE, 2010
- [3] Doherty R., Mullane A., Nolan G., Burke D.J.: 'An assessment of the impact of wind generation on system frequency control', *IEEE Trans. Power Syst.*, 2010, **25**, (1), pp. 452–460
- [4] Ummels B.C., Madeleine G., Kling W.L., Paap G.C.: 'Performance of automatic generation control mechanisms with large-scale wind power'. Nordic Wind Power Conf., 2007
- [5] Bi Hui L., Hong S., Yong T., Hongyun Z., Feng S., Dong Fu L.: 'Study on the frequency control method and AGC model of wind power integration based on the full dynamic process simulation program'. Int. Conf. on Power System Automation and Protection (APAP), IEEE, Beijing, 2011
- [6] Aho J., Bucksan A., Pao L., Fleming P.: 'An active power control system for wind turbines capable of primary and secondary frequency control for supporting grid reliability'. Proc. 51st AIAA Aerospace Sciences Meeting Including the New Horizons, January 2013
- [7] Antonishen M.P., Hai H.Y., Brekken T.K.A., *ET AL.*: 'A methodology to enable wind farm participation in automatic generation control using energy storage devices'. Power and Energy Society General Meeting, IEEE, San Diego, CA, 2012
- [8] Zhu J., Cheung K.: 'Analysis of regulating wind power for power systems'. Power & Energy Society General Meeting, IEEE, Calgary, AB, 26–30 July 2009
- [9] Vittrup C.: '2013 was a record-setting year for Danish wind power'. Energinet.dk, 15 January 2014. [Online]. Available at <http://www.energinet.dk/EN/El/Nyheder/Sider/2013-var-et-rekordaar-for-dansk-vindkraft.aspx>, accessed 06 February 2014
- [10] Skødt T.: 'Electricity interconnections'. Energinet.dk, 20 February 2014. [Online]
- [11] Basit A., Hansen A.D., Sørensen P.: 'Dynamic model of frequency control in Danish power system with large scale integration of wind power'. China Wind Power (CWP) Conf., Beijing, 2013
- [12] Working Group on Prime Mover and Energy Supply Models for System Dynamic Performance Studies: 'Dynamic models for fossil fuelled steam units in power system studies', *IEEE Trans. Power Syst.*, 1991, **6**, (2), pp. 753–761
- [13] IEEE Committee Report: 'Dynamic models for steam and hydro turbines in power system studies', *IEEE Trans. Power Appar. Syst.*, 1973, **PAS-92**, (6), pp. 1904–1915

- [14] CIGRE Task Force 25 of Advisory Group 02 of Study Committee C4: 'Modeling of gas turbines and steam turbines in combined cycle power plants'. CIGRE, 2003
- [15] IEC 61400-27 Committee Draft, Wind Turbines Part 27-1: 'Electrical simulation models for wind power generation Wind turbines'. IEC Std. committee Draft (CD) 88/424/CD, 2012
- [16] Grande O.S., Doorman G., Bakken B.H.: 'Exchange of balancing resources between the Nordic synchronous system and the Netherlands/Germany/Poland'. SINTEF, 2008
- [17] ENTSO-E: 'Continental Europe Operation Handbook – p1: load-frequency control and performance', [Online]. Available at <https://www.entsoe.eu/publications/system-operations-reports/operation-handbook/>, accessed September 2013
- [18] Hamon C.: 'On frequency control schemes in power systems with large amounts of wind power' (KTH School of Electrical Engineering, Stockholm, 2012)
- [19] Gjengedal T.: 'System control of large scale wind power by use of automatic generation control (AGC)'. Quality and Security of Electric Power Delivery Systems, 2003.CIGRE/PES 2003. CIGRE/IEEE PES Int. Symp. 8–10 October 2003, vol., no., pp. 15–21
- [20] Prabha K.: 'Power system stability and control' (McGraw-Hill, 1994)
- [21] Rebours Y.G., Kirschen D.S., Trotignon M., Rossignol S.: 'A survey of frequency and voltage control ancillary services – part i: technical features', *IEEE Trans. Power Syst.*, 2007, **22**, (1), pp. 350–357

P 2: Basit A.; Hansen A. D.; Altin M.; Sørensen P.; Gamst M.: “Compensating Active Power Imbalances in a power system with high wind power penetration” Submitted to Journal of modern power system and clean energy

Compensating active power imbalances in a power system with high wind power penetration



A. Basit, A.D. Hansen, M. Altin, P. Sørensen and M. Gamst

Abstract Large scale wind power penetration may affect the supply continuity in the power system. This aspect is a matter of high priority to investigate, as more regulating reserves and specified control strategies for generation control are required in the future power system with even more high wind power penetration. The emphasis in this article is on the evaluation of the impact of large scale integration of wind power on future power systems. The present work proposes an active power balance control methodology for compensating the power imbalances between demand and generation in real time, caused by wind power forecast errors. This methodology, which can be applied for the balance power control of future power systems with large scale wind power integration, is described and exemplified considering the generation and power exchange capacities in the year 2020 for Danish power system.

Keywords Wind Power Plant (WPP), SimBa, centralised or de-centralised combined heat and power plant (CHP or DCHP), Automatic Generation Control (AGC)

1 Introduction

The foremost task of any transmission system operator (TSO) is to maintain a reliable and secure power system operation and afterwards to minimize the production cost, even in conditions with high wind power penetration. The wind speed forecast in a heavily wind power integrated

power system plays an important role in the power balance planning. An incorrect wind speed forecast might deviate the generation and the power exchange plan with neighbouring power systems from the cost effective calculated schedule. This fact can lead to power system balancing and control problems and can introduce several challenges in maintaining a reliable and secure power system operation [1]. In spite of these challenges, the interest in the integration of large wind power into power systems has motivated and enhanced new opportunities in modelling and control of power system research. Adequate methodologies for studying power system dynamics and control, like the present one, on the active power balance control, are of high relevance for the future power systems.

Several studies on active power balancing in a large scale wind power integrated power system have been performed and presented in the literature [2 – 5] over the years. In [2], the performance of the secondary control action and the regulating power control from conventional power plants is analysed, while in [3] it is stated that response of the thermal power plants used in power balance control is mainly determined by their active power ramp rate. In [4], where a Dutch case study is described to assess the Automatic Generation Control (AGC) performance in the presence of large scale wind power and it is concluded that additional reserves from thermal power plants are required for keeping the area control error at the same level. Recent Chinese studies [5] have led to the conclusion that, the power imbalances from wind power plants (WPPs) can be controlled via conventional generators. Nevertheless, further studies and control methodologies for balancing the active power in power systems with large scale wind power integration, taking into account hour-ahead dispatch power plan for generating plants and power exchange with neighbouring power systems, are necessary to enhance the stability of future power systems with high wind power penetration. In this respect, conventional market models are important to be considered as well, as they are simulating optimal unit commitment and dispatch of power plants with one hour resolution [6]. However, in

Received: 12 September 2014 / Accepted: 20 January 2015

A. Basit, A.D. Hansen, M. Altin and P. Sørensen: Technical University of Denmark, Department of Wind Energy, Frederiksborgvej 399, 4000 Roskilde, Denmark

A. Basit, Sino-Danish Center for Education and Research, Niels Jensens Vej 2, 8000 Aarhus, Denmark

M. Gamst, Energinet.dk, Tonne Kjærvej 65, 7000 Fredericia, Denmark

✉ e-mail: abdl@dtu.dk



order to manage the wind power forecast errors in a large scale wind power integrated power system, a dispatch plan for the power plants with a smaller resolution than one hour is necessary.

In a large interconnected power system, power balance is one of the main challenges that need to be evaluated for large scale integration of wind power. The objective of this article is to present a new methodology for active power balance control for future interconnected power system with large scale wind power penetration. The novelty of this work is that the proposed control methodology uses an hour-ahead regulating power plan in a time scale of five minutes to compensate the real time active power imbalances in the power system. This methodology can be used as a guideline for the TSOs, to investigate their power balancing capabilities considering WPPs. The Danish power system is used for the implementation and verification of this methodology because of its big wind power penetration goal quote, i.e. 50% of the total electricity production from wind power by 2020 [7].

The article is structured as follows. A brief description of the impact of the fluctuated nature of the wind on the power system operation is provided first. Then the proposed active power balance control methodology is described, approaching also the aspects regarding the AGC and the generation of the hour-ahead regulating power plan. The high wind penetration scenarios for the Danish power system in year 2020 are used to assess the performance of the methodology through a set of simulations with the developed Danish power system model. Finally, conclusive remarks are reported in the final section.

2 Wind power impacts on power system operation

Wind speed is always fluctuating and so is the power generated from wind turbines (WTs). The fluctuating and uncertain nature of wind may introduce several challenges in the maintenance of the power balance in a power system with large wind power integration. No matter what, the TSOs have the responsibility to preserve a reliable power system operation and ensure a secure power supply, while keeping the generation at lowest possible cost.

Active power reserves are always needed to keep the power system in balance and their amount depends also on the level of wind power penetration into the power system and on forecasted weather conditions. For example, extreme weather conditions may result in loss of large amount of wind power within few minutes, jeopardizing the reliability and the security of the power system operation [1]. Therefore reserves are typically needed from fast conventional generating units to increase the system reliability and to ensure the power supply security. According to European Network of Transmission System

Operators for Electricity (ENTSO-E), the type of reserves needed to keep the power system in balance can be classified as Frequency Containment Reserves (FCR), Frequency Restoration Reserves (FRR) and Replacement Reserves (RR) [8, 9]. FCR are activated automatically and locally within 30 seconds for constant containment of frequency deviations and to constantly maintain the power balance in the whole synchronously interconnected system. FRR are typically activated (manually or automatically) within 15 minutes, in order to maintain the active power balance in the power system and the power exchange with neighbouring power system at its schedule. RR responds in several minutes up to hours and restores the FCR and FRR back to the required level. The total volume of FCR in Continental Europe and Nordic region is ± 3000 MW and ± 600 MW, respectively [9]. However, as wind power impacts the power system operation, it is predicted that more reserves will be needed in the future to accommodate large amount of wind power into the power systems. In this study power imbalance is controlled through FCR and FRR. Conventional and wind power plants provides the FCR, while FRR is activated only from conventional power plants through AGC.

3 Active power control methodology

A methodology to control the active power imbalance in a large scale wind power integrated power system is presented in this study. The proposed methodology uses an hour-ahead regulating power plan in a time scale of five minutes for the power plants and power exchange with neighbouring power systems. The following subsections explain the generation of hour-ahead regulating power plan by a balancing program and the AGC model developed for this study.

3.1 Hour-ahead regulating power plan

The generated power in a power system is typically traded by the balancing responsible companies on the spot-market [7]. Two standard power balancing programs, namely WILMAR and SimBa, are used in the present work to generate the day-ahead and hour-ahead time series. WILMAR stands for 'Wind Power Integration in Liberalised Electricity Markets', while SimBa stands for Simulation power Balancing. A detailed description of these programs is out of the scope of the present work. However, more details on WILMAR and SimBa can be found in [10 – 13] and [7 & 14], respectively.

The WILMAR is an example of a program used to model the spot market as a perfect market with a unit commitment and dispatch model. The hourly bids for purchase and sale are selected one day prior to physical delivery and therefore referred as a day-ahead market. Within this process, the bids are selected with foremost

intent of preserving system integrity and then to minimize the overall operating cost. The bids selection is subjected to different constraints, such as transmission constraints in the electricity system and capacity constraints of storage and generating technologies.

The balance day-ahead agreements come out of balance because of wind power forecast errors or unavailability of generating units. The power balance can then be restored by trading on an intra-day balancing power market. For example, based on updated forecasts, the Danish TSO uses the Nordic Operational Information System (NOIS) list and generates an hour-ahead plan for the intra-hour balance with five minute resolution, through simulations with a dedicated power balancing program, known as SimBa [7 & 14]. SimBa models the power system in detail, taking the current grid regulations and the energy market rules continuously into account. It uses inputs from unit commitment models including hourly values for energy production, load and the power exchange between interconnected areas. These inputs to the SimBa program are provided by WILMAR model, while Correlated Wind power fluctuations (CorWind) model provides the day-ahead and hour-ahead forecasts of wind power and the available wind power.

With the balanced hourly time series provided by WILMAR, SimBa starts to update the day-ahead schedule with a five-minute time resolution taking in account the ramping on interconnection lines and power plants. It then estimates the fluctuations from hour-ahead wind power forecast and generates the possible wind power schedule in a five minute resolution within the operating hour. Based on the possible wind power schedule and the updated day-ahead schedule, SimBa calculates the mean imbalance for half an hour and balances the power system internally in different areas, considering the grid regulation, transmission losses and transmission constraints. It activates the bids from NOIS list, while taking in account the minimum activation time (30 minutes) and minimum bid level (10 MW) [14]. With above mentioned constraints, SimBa then provides the balanced hour-ahead plan for generating units and power exchange with neighbouring power systems with five minute resolution. Figure 1 illustrates how SimBa, based on the inputs from CorWind and WILMAR generates the hour-ahead input to the dynamic power system model, where the AGC is acting.

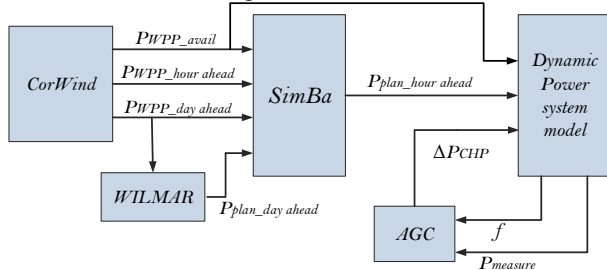

Figure 1: Overview of the signals between CorWind, WILMAR, SimBa, the dynamic power system model and the AGC

SimBa creates an upward and downward regulation list of bids based on the marginal cost function, bidding price and production capacity for each unit. Due to the uncertain nature of wind, the wind power within the operating hour may not be the same as its estimated value and this aspect can create power imbalance within the operating hour. This imbalance is partially compensated by FRR, i.e. through activation of additional regulating bids in the control room from the NOIS list and with an AGC having reserved capacity of ± 90 MW acting on the border of Western Denmark with Germany [7]. However, for the present investigation, it is assumed that the power imbalance within the operating hour is controlled only through AGC, by providing ΔP_{SET} to the conventional power plant (i.e. centralised combined heat and power plant (CHP)) as a secondary response.

3.2 Automatic Generation Control (AGC)

The AGC is used to routinely balance the power system and to make the power system operation more reliable [15]. The AGC, developed and implemented in this investigation, is sketched in Figure 2. The goal of the AGC, depending on available secondary power, is to reduce the area control error (P_{ACE}) to zero. The P_{ACE} is calculated based on the change in system frequency (Δf) and on a possible power mismatch (ΔP) between generations, power exchange and system load, as follows:

$$P_{ACE} = -\Delta P - (\Delta f \times B) \tag{1}$$

$$\Delta P = P_G - P_{exchange} - P_{Load} \tag{2}$$

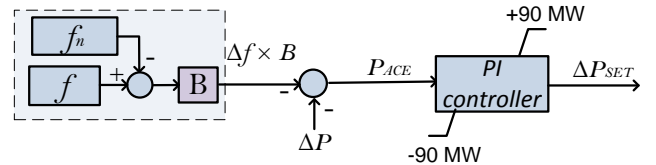

Figure 2: AGC model

where, PG is the power generated by CHPs, de-centralised combined heat and power plant DCHPs and WPPs in real time. The system frequency bias factor B [MW/Hz] is determined from the droop characteristics of all generating units taking part in the primary response. The frequency bias factor is reflecting the power ability (and thus FCR) of the generating units to compensate for a frequency changes. The overall secondary response from AGC, i.e. ΔP_{SET} , is decided by a PI controller based on the equation shown below, where K and T are the gain and integration time constant, respectively:

$$\Delta P_{SET} = K \times P_{ACE} + \frac{1}{T} \int P_{ACE} \tag{3}$$

ΔP_{SET} represents the required change in the participating generating power set points in the imbalanced area. In this study, an AGC with a capacity of ± 90 MW is implemented to investigate the impact of large scale integration of wind power on future power systems during power imbalances between demand and generation,

caused by wind power forecast errors. The wind power is not integrated in AGC in the present study, as this is a part of the next upcoming investigation.

4 Simulation based validation of the methodology

As mentioned before, the Danish power system is used to validate the performance of the proposed active power control methodology. The following sub-sections will explain the future Danish power system model and a set of simulations assessing the performance of the proposed active power control methodology.

4.1 Danish power system case study

The developed Danish power system model reflects the most relevant dynamics of the power system with respect to active power balancing control issues. It includes models for the AGC system, centralised or de-centralised combined heat and power plant (CHP and DCHP), WPP and interconnections with neighbouring power system.

As the focus of this investigation is on active power balance control, the transmission losses are ignored and the power system is designed as a two bus system, shown in Figure 3. The system interconnections and the generating unit models in the Danish power system are shortly explained below.

4.1.1 System interconnection

The Danish power system is composed of two power systems, i.e. Eastern and Western Danish power systems. They are connected together through an HVDC connection, i.e. Great Belt Link (GBL) having a transmission capacity of 600 MW. They are also connected to the strong neighbouring power systems of Germany, Sweden and Norway. The Eastern Danish power system is synchronized with the Nordic power system, whereas the Western Danish power system is synchronized with the continental European power system. The interconnection capacities of Danish power system with its neighbouring powers as planned for the year 2020 are shown in Figure 4 [16], where AC interconnections are presented as dotted lines and DC interconnections as solid lines.

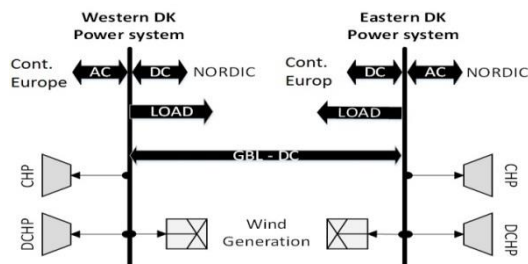

Figure 3: Danish power system model overview

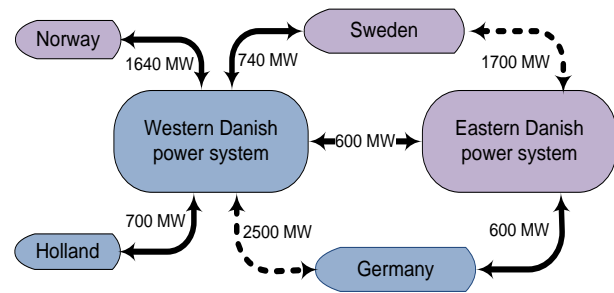

Figure 4: Denmark interconnection capacities as planned for 2020

Denmark's neighboring power systems ramp the agreed power exchange in different durations and at different starting times. For example, in the Nordic power system, the agreed power exchange shall be ramped within 30 minutes and shall begin 15 minutes before the agreed exchange hour. Meanwhile, in the continental European power system, the power exchange shall be ramped within 10 minutes and shall start 5 minutes before the agreed exchange hour [15]. If the power has to be transported from the Nordic power system to the continental European power system or vice versa, the difference in power exchange ramping might lead to a power imbalance in Danish power system at an agreed hour.

4.1.2 Electrical power generating units

The electrical power generation in Denmark is a combination of conventional and renewable generation sources. The conventional power generation is typically based on CHPs and DCHPs, while renewable generation is basically from WPPs. In the following, aggregated models of power generating units used in the Danish power system, reflecting their most relevant dynamic features, are briefly described.

A. Conventional power plants

Aggregated models for CHP and DCHP are frequently described in the literature [17 – 18]. It is worth mentioning that, the response time and ramp rates associated with CHP are in order of minutes and they are the dominant characteristic for power system studies. Shortly, an aggregated CHP model consists of a thermal boiler, a boiler turbine controller, a steam turbine and a speed governor, while, an aggregated DCHP model includes gas turbine and a speed governor.

In the proposed methodology, the reference power signal for CHP or DCHP is calculated based on the planned power from SimBa and the power correction from the AGC. The speed governor of the generating units activates the FCR, if the frequency deviates by ± 0.01 Hz. The amount of activated FCR depends on the droop characteristic of the governor of each generating unit (i.e. 4% in this study).

B. Wind Power plant

The aggregated modelling of WPP is commonly used to facilitate power system studies, where the concern is not on the performance of an individual WT, but rather on the impact of an entire WPP on the power system. The idea of using the aggregation method is to reduce computational effort, while maintaining the capability to predict unit influence on system dynamic behaviour. A simplified generic aggregated WPP model is therefore developed in this work for long term dynamic simulation studies, with starting point from the IEC61400-27-1 Committee Draft for electrical simulation models for wind power generation [19]. However, for the specific purpose of this study, the model is further simplified and adjusted to be able reflect correctly the dynamic features for active power and frequency control capability studies, i.e. primary control from WPP.

The aggregated WPP model, shown in Figure 5, has a hierarchy structure, namely that there is WPP active power control level and a WT active power control level. The power reference P_{ref} to the WT active power controller is generated by the WPP active power controller, based on the primary response signal (ΔP_c), the available wind power signal (P_{WPP_avail}) from the power balancing model and the measured power in the Point of Common Connection (PCC). As illustrated in Figure 5, the control both in the WT and in the WPP level is realised by using PI controllers. For example, the PI controller in the WPP active power controller reduces the error between measured power at PCC (P_{meas_PCC}) and the sum between the available power and the primary response signal (P_{WPP_avail} & ΔP_c), in the decision of the Pref.

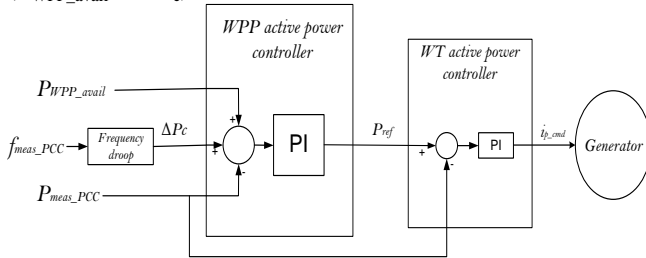

Figure 5: Aggregated WPP model

The frequency droop block in Figure 5, decides the ΔP_c for the aggregated WPP model, based on the droop setting. The typical value of 4% is used in this work for the droop setting. The primary response capability of WPP is however strongly dependent on the availability of reserve power. Figure 6 shows for example the dynamic primary response from the WPP with a nominal power of 2800 MW, when a negative load step results in a frequency change of -0.034 Hz.

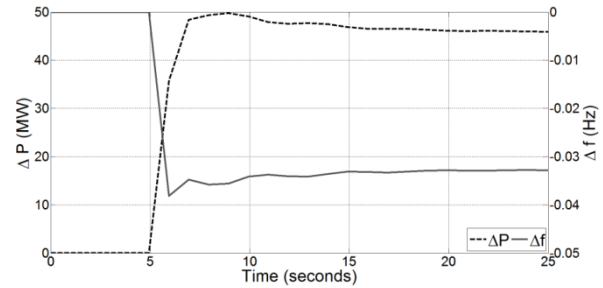

Figure 6: WPP primary response for a load step

The new steady state response from the WPP is then calculated as following:

$$\Delta P = -\Delta f \times \beta \tag{4}$$

Where,

$$\beta = \frac{P_{WPP_nominal}}{R \times f} = \frac{2800}{0.04 \times 50} = 1400 \text{ MW/Hz} \tag{5}$$

$$\rightarrow \Delta P = -\Delta f \times \beta = -(-0.034) \times 1400 = 47.6 \text{ MW} \tag{6}$$

Thus following a load step, the WPP shares a load of 47.6 MW by increasing its production in order to stabilize the system frequency.

4.2 Simulations and Results

Different studies are carried out in the following to assess the performance of the proposed active power control methodology. A set of simulations are performed using time series for generation, load and power exchange corresponding to one particular winter day. The time series are generated by SimBa for the scenario of the year 2020 for the Danish power system based on the real data from the year 2009. It is assumed that, the power exchange is kept at its planned level within the operating hour, while the conventional generating units change their power set point from planned schedule as directed by AGC for any power imbalance. The power generated within the operating hour from conventional and wind power plants, as well as the net exports with neighbouring power systems and the load demand in the Eastern and Western Danish power systems are shown in Figure 7 and Figure 8, respectively. The net exports are calculated by subtracting the total import power from total export power.

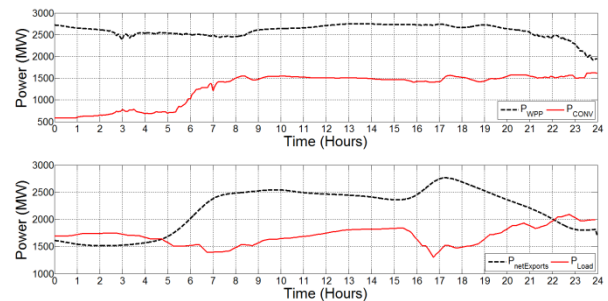

Figure 7: Generation, load and net exports within the operating hour – East Denmark



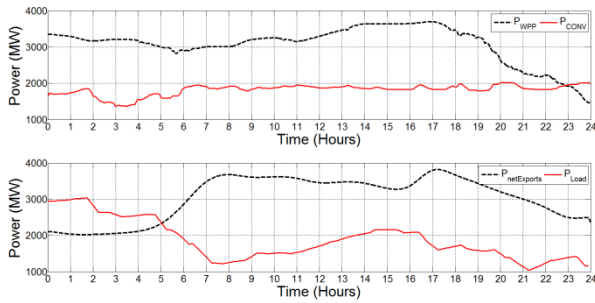

Figure 8: Generation, load and net exports within the operating hour – West Denmark

Notice that, on the considered day, the availability of wind allows the WPPs to generate more power than conventional power plants. In Eastern Denmark, the conventional power plants generated 30.81 GWh of electricity, while WPPs generated 62.17 GWh, i.e. 66.85% of the total electricity production. The high production from WPPs allows the net exports of 40.533 GWh from Eastern Danish power system, when the load demand was 52.422 GWh. Alike in Western Denmark, 43.83 GWh is generated from conventional power plants and 73.97 GWh from WPP, i.e. 62.8%. While, the total load demand and the net exports are 73.075 GWh and 44.612 GWh, respectively. The generation from WPPs can meet the load demand in Eastern and Western Danish power systems, but the conventional power plants are operating to uphold the system reliability in case of unforeseen events. The availability of wind power and the high load demand, in the large scale wind power integrated power system, motivates to investigate the system behaviour on this particular day.

As aforementioned in Denmark, the electricity markets are balanced taking in account the hour-ahead forecasts of wind and load. If the available wind power generated within the operating hour differs from the forecast, a power mismatch between generation and load will appear. The power mismatch yields to a change in the system frequency and deviation in power exchange from its hour-ahead schedule. The generating units equipped with speed governors will respond to the deviations by releasing FCR. Afterwards, the FRR from the AGC, depending on reserves availability, will return the system frequency to its nominal level and consequently replaces FCR.

Figure 9 shows for example the governor response from the WPP and conventional power plants (CHP+DCHP) as a result of wind power forecast error in Eastern and Western Danish power system respectively, while Figure 10 shows the area control error (P_{ACE}) after the AGC response (ΔP_{SET}) in these power systems. The governor response depends on their droop setting and also on their generating capacity. The WPP and the conventional power plants have the same droop setting, but the response is higher in case of WPP owing to its higher generation capacity, as illustrated in Figure 9. However, the activation

of FCR is subjected to reserves availability. These reserves are activated within 30 seconds and continue to be activated, as the power imbalance is changing continuously, until FRR through AGC removes the power imbalance.

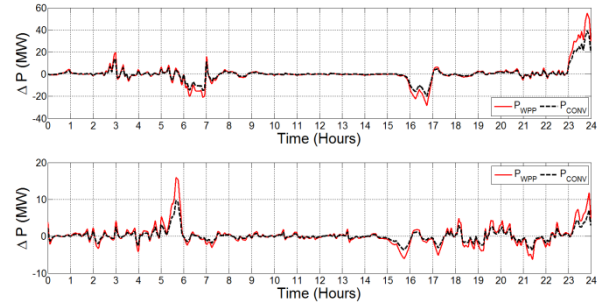

Figure 9: Governor Response to power imbalance – top: Eastern Denmark, bottom: Western Denmark

The AGC continuously respond to the power mismatch between generation and load by providing new power set point to the generating unit and tries to reduce the power imbalance (P_{ACE}) in the power system. However, the power imbalance in these power systems does not always return to zero level, as ΔP_{SET} is limited to ± 90 MW and also lags behind P_{ACE} due to the delays associated with the AGC and CHP, which abstains them to change their output at the required rate i.e. P_{ACE} rate. These delays are caused due to the ramp in the reference power considered in this study (i.e. 30 MW/min) and also due to the slow boiler response of CHP units (i.e. the boiler needs 5 – 6 minutes to modify its output pressure when demanded). The power imbalances deviates the system frequencies from their nominal level, as shown in Figure 11 for the Eastern and Western Danish power systems.

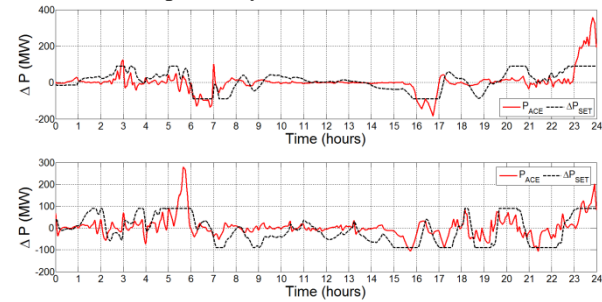

Figure 10: P_{ACE} and ΔP_{SET} from AGC – top: Eastern Denmark, bottom, Western Denmark

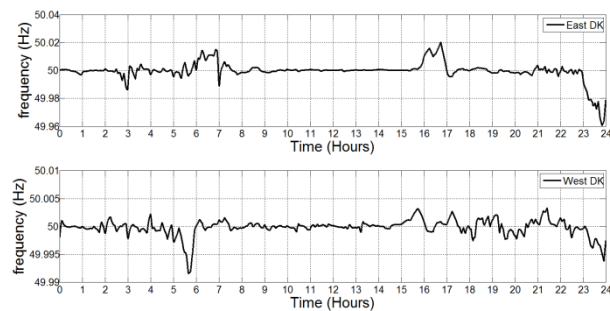

Figure 11: System frequency

The system frequency deviation illustrated in Figure 11 relates to the amount of power imbalance. The surplus power results in frequency rise, while the deficit in frequency drop. Notice that, in spite of a large power imbalance, as illustrated in Figure 12, the deviation in system frequency from its nominal level is insignificant, as the Danish power system is synchronously connected to stiff and large continental European and Nordic power systems. The strong neighbouring interconnections offer huge frequency bias and stabilize the frequency in Danish power system. However, the power imbalance will divert the power exchange from its schedule and may overload the tie line. The secondary support from AGC will lower the power imbalance in real time arising due to the wind power forecast error. Figure 12 compares the power imbalance in the Eastern and Western Danish power systems with and without AGC support. The simulations show that the AGC system reduces the real time power imbalances and makes power system operation more reliable.

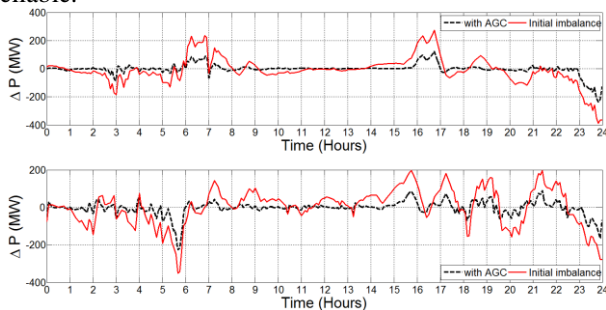

Figure 12: Power imbalance with and without AGC – top: Eastern Denmark, bottom: Western Denmark

5 Conclusion

The integration of large amount of wind power into future power systems presents several challenges, as for example the power system balancing and the availability of the regulating reserves. This article describes and analyses the challenges in the future power systems with the large scale integration of wind power. It proposes a methodology for the active power balance control taking in account the hour-ahead regulating power plan with reduced planning horizon, dispatching the power plants and the power exchange in a time scale of five minutes. The hour-ahead plan efficiently addresses the intermittent wind power and reduces the regulation burden that would be required in a dispatch plan of one hour. The AGC further compensates the power imbalances between demand and generation in a real time, provoked by wind power forecast errors. The Danish power system is used as a case study in the verification of the proposed method. The studies performed and presented in this article illustrate how imbalances between demand and generation can be compensated with reduced dispatch plan and by regulating the active power production from conventional power

plants through AGC.

It has been illustrated through a set of simulations that the AGC can effectively control the real time power imbalances due to the wind power forecast errors, by controlling the generation from conventional power plants. Furthermore, it has been seen that the regulating reserves are needed from fast conventional power plants to maintain system balance and the amount depends on the level of wind power integration. Better forecasting of wind speed and the load demand is desirable in a large wind power integrated power system. It has also been depicted that the interconnections with strong electrical networks stabilizes the system frequency and decides the wind power integration level.

The proposed methodology in this article provides guidelines on how large wind power can be integrated in the planning, control and operation of future power system. Further research can also investigate the WPPs participation in secondary frequency regulations by integrating the WPP control in the AGC system, to ensure secure and reliable operation of a large scale wind power integrated power system. Another topic for future investigation might be to find the cost effective solution to deal with larger power imbalance in a large scale wind power integrated power system.

6 Acknowledgement

This paper is a part of PhD project funded by Sino-Danish centre for education and research (SDC).

References

- [1] Suwannarat A, "Integration and Control of Wind Farms in the Danish Electricity System," Institute of Energy Technology Aalborg University, Aalborg, 2007.
- [2] Suwannarat A, Bak-Jensen B, Chen Z, Nielsen H, Hjerrild J, Sørensen P and Hansen AD, "Power System Operation with Large Scale Wind Power Integration," in IEEE Power Tech, Lausanne, 2007.
- [3] Egido I, Fernández-Bernal F, Rouco L, Porrás E, and Sáiz-Chicharro A, "Modeling of Thermal Generating Units for Automatic Generation Control Purposes," IEEE Transactions on Control Systems technology, vol. 12, no. 1, January 2004.
- [4] Ummels BC, Gibescu M, Kling WL and Paap GC, "Performance of Automatic Generation Control Mechanisms with Large-Scale Wind Power," in Nordic Wind Power Conference, 2007.
- [5] BiHui L, Hong S, Yong T, Hongyun Z, Feng S, and Dongfu L, "Study on the frequency control method and AGC model of wind power integration based on the full dynamic process simulation program," in International Conference on Power System Automation and Protection (APAP), IEEE, Beijing, 2011.
- [6] Sørensen P, Norheim I, Meibom P and Uhlen K, "Simulations of wind power integration with complementary power system planning tools," Electric Power Systems Research, p. 1069–1079, 2007.
- [7] Basit A.; Hansen A. D.; Altin M.; Sørensen P.; Gamst M.: 'Wind power integration into the automatic generation control of power



- systems with large-scale wind power', *The Journal of Engineering*, 1 (1), DOI: 10.1049/joe.2014.0222, IET Digital Library, <http://digital-library.theiet.org/content/journals/10.1049/joe.2014.0222>
- [8] Abbad JR, "Electricity market participation of wind farms: the success story of the Spanish pragmatism," *Energy Policy*, vol. 38, no. 7, p. 3174–3179, 2010.
- [9] Grande OS, Doorman G and Bakken BH, "Exchange of balancing resources between the Nordic synchronous system and the Netherlands / Germany / Poland," SINTEF, 2008.
- [10] Meibom P, Morthorst PE, Nielsen LH, Weber C, Sander K, Swider D, Ravn H, "Power System Models - A Description of Power Markets and Outline of Market Modelling in Wilmar," Risø-R-1441, 2003.
- [11] Meibom P, Barth R, Norheim I, Ravn H, Sørensen P, "Final Technical Report - Wind Power Integration in a Liberalised Electricity Market," Risø National Laboratory, January 2006.
- [12] Barth R, Weber C, "WILMAR, Deliverable D7.1 - Distribution of the integration costs of wind power," Institute of Energy Economics and the Rational Use of Energy University of Stuttgart, November 2005.
- [13] Meibom P, Larsen HV, Barth R, Brand H, Weber C, Voll O, "Wilmar, Deliverable D6.2 (b) - Wilmar Joint Market Model Documentation," Risø-R-1552(EN), Roskilde, Denmark, January 2006.
- [14] Hansen AB, Orths A, Falk K, Detlefsen NK, "Danish Fossil Independent Energy System 2050- From Strategic Investigations to Intra-Hour Simulation of Balancing Issues," in 10th International Workshop on Large-Scale Integration of Wind Power into Power Systems, Aarhus, 2011.
- [15] "Operation Handbook, P1-Policy 1: Load-Frequency Control and Performance," ENTSOE-E, March, 2010.
- [16] Skødt T, "Electricity interconnections," *Energinet.dk*, 20 February 2014. [Online]. Available: <https://www.energinet.dk/EN/ANLAEG-OG-PROJEKTER/Generelt-om-elanlaeg/Sider/Elforbindelser-til-udlandet.aspx>.
- [17] I.C. Report, "Dynamic Models for Steam and Hydro Turbines in Power System Studies," *IEEE Transactions on Power Apparatus and Systems*, Vols. PAS-92, no. 6, pp. 1904-1915, November 1973.
- [18] CIGRE Task Force 25 of Advisory Group 02 of Study Committee C4, "Modeling of Gas Turbines and Steam Turbines in Combined Cycle Power Plants," CIGRE, 2003.
- [19] IEC 61400-27 Committee Draft, Wind Turbines Part 27-1, "Electrical simulation models for wind power generation Wind turbines," IEC Std. committee Draft (CD) 88/424/CD, 2012.

Author Biographies

Abdul Basit received the B.Sc. degree in electrical engineering from the University of Engineering & Technology, Peshawar, Pakistan in 2006 and M.Sc. degree in electrical power engineering from Chalmers University of Technology, Sweden in 2011.

He is currently employed as a PhD student at Department of Wind Energy of the Technical University of Denmark (DTU). His research interest includes integration of wind power into power systems, automatic generation control, wind power plant control, and power systems.

Anca D. Hansen received the degree in aerospace engineering from the Technical University of Bucharest, Romania, in 1992 and a Ph.D. degree in modelling and control engineering from Denmark Technical University in 1996. In 1998, she joined Risø National Laboratory, working first as PostDoc and then a scientist with modelling and control of wind turbines. Today, she is working as Senior Scientist in the DTU Wind Energy department, former Risø National Laboratory, in Denmark. Her research interest is integration of wind power into power systems, involving different technical topics on dynamic modelling and control of wind power plants, ancillary services as well as power system control and stability topics. She is author or co-author of more than 100 journal/conference papers, several research reports in her research fields.

Mufit Altin received B.Sc. and M.Sc. degrees in electrical and electronics engineering from the Middle East Technical University (METU), Ankara in 2004 and 2009, respectively. He obtained his PhD degree from the Department of Energy Technology, Aalborg University, Denmark, in 2012, where he was employed as a researcher under the Vestas Power Programme during his PhD. He joined and is currently working as a postdoc at Department of Wind Energy of the Technical University of Denmark (DTU). His research interest includes distribution automation, wind power plant control, wind energy, and power systems.

Poul E. Sørensen was born in 1958. He received the M.Sc. degree in electrical engineering from the Technical University of Denmark, Copenhagen, Denmark, in 1987. Since 1987, he has been at Risø National Laboratory, Roskilde, where he is currently a Professor. His research interests include integration of wind power into power systems, involving a variety of technical disciplines including power system control and stability, dynamic modeling and control of wind turbines and wind farms, and wind fluctuation statistics. Prof. Sørensen is convener of the IEC 61400-27 working group.

Mette Gamst received B.Sc. and M.Sc. degrees in computer science from the University of Copenhagen, Denmark in 2004 and 2007, respectively. She obtained her PhD degree from the DTU Management Engineering, Technical University of Denmark in 2010. She is currently working as system analyst in Energinet.dk.

P 3: Basit A.; Hansen A. D.; Altin M.; Sørensen P.; Giannopoulos G, "Real-time impact of power balancing on power system operation with large scale integration of wind power" Submitted to Journal of modern power system and clean energy

Real-time impact of power balancing on power system operation with large scale integration of wind power

A. Basit^{1,*§}, A.D. Hansen*, P. Sørensen* and G. Giannopoulos[‡]

* Technical University of Denmark, Department of Wind Energy, Frederiksborgvej 399, Building 125, 4000 Roskilde, Denmark

§ Sino-Danish Centre for Education and Research, Niels Jensens Vej 2, 8000 Aarhus, Denmark

‡ ELIA SYSTEM OPERATOR, Keizerslaan 20, 1000 Brussels, Belgium

Abstract – Highly wind power integrated power system requires continuous active power regulation to tackle the power imbalances resulting from the wind power forecast errors. The active power balance is maintained in real-time with the automatic generation control and also from the control room, where regulating power bids are activated manually. In this article, an algorithm is developed to simulate the activation of regulating power bids, as performed in the control room, during power imbalance between generation and load demand. In addition, the active power balance is also controlled through automatic generation control, where coordinated control strategy between combined heat and power plants and wind power plant enhances the secure power system operation. The developed algorithm emulating the control room response, to deal with real-time power imbalance, is applied and investigated on the future Danish power system model. The power system model takes the hour-ahead regulating power plan from power balancing model and the generation and power exchange capacities for the year 2020 into account. The real-time impact of power balancing in a highly wind power integrated power system is assessed and discussed by means of simulations for different possible scenarios.

1 Introduction

Increasing wind power integration influences the technical operation of a power system, particularly the active power balance control between generation and demand. The variable wind power generation together with the technical capabilities of the generating units and the market rules might hinder the power system balance control. These factors must be taken into account while planning the power balancing operation of a large scale wind power integrated power system.

The Transmission System Operators (TSOs) have to securely operate the power system in transporting the generated electricity to the end consumers. In deregulated power systems, the electricity is traded in electricity markets by the balance responsible companies that can produce, consume or retail. Examples of electricity markets are the Day-ahead (DA), intraday and regulating power markets [1]. The balance responsible trades in DA market and balance the power system for each operating period in the next day. If the power system comes out of balance on an operating day, owing to the update of wind power forecasts or the unavailability of power plants, the balance responsible trades again in intraday market for every operating period to one hour in advance of the actual operation hour. The intraday market balances the power system. However wind power forecast errors and other non-contingent events might create power imbalance within the actual operating hour. These imbalances are then minimized by activating the power bids, within minutes, from regulating power market. The TSOs select the dispatch bids with the foremost intent of preserving system integrity with minimum production cost.

¹ Corresponding author: Tel.: +45 2492 1623; Fax: +45 4677 5083; E-mail address: abdl@dtu.dk (A. Basit)

With increasing large scale integration wind power, active power balancing is becoming a challenging technical issue. Several studies have been performed in this area over the last few years. For example, according to [2], the increasing integration of wind power alters the frequency behaviour and solutions must be developed to meet these challenges. A Dutch case study in [3] shows that additional regulating reserves are required in the presence of large scale wind power. The Chinese studies in [4] have led to the conclusion that the fluctuation from WPPs can be controlled via conventional generators. According to [5], the WPPs can participate in frequency regulation services with energy storage devices such as super capacitor banks, while [6] examines the benefits of active power regulation from WPPs. However to enhance the operational security of the power system, further studies on the system level is the need of the hour.

Real-time control of the regulating power is necessary for reliable and secure operation of future power system with large scale wind power integration. The objective of this article is to study how active power balance can be controlled in real-time with coordinated automatic generation control (AGC) action between Combined Heat and Power Plants (CHPs) and Wind Power Plant (WPPs) and by activating the regulating power bids, as performed in the control room. For this purpose, an algorithm named as '*rolling balance*' has been developed for this study which emulates the real-time control room response while activating the regulating bids.

To study the real-time active power balance control in a power system with high wind power penetration level, the *rolling balance* is exemplified on the future Danish power system corresponding to year 2020, where 50% of the total electricity production has to be supplied by wind power [7]. The balanced regulating power plan, in a five minute resolution, for generation and power exchange with neighbouring power systems is provided by hour-ahead (HA) power balancing program. However, wind power forecast errors and other events might cause a power imbalance in the real time, which can be partially compensated by activating the additional regulating power with a *rolling balance* and the coordinated AGC response. The *rolling balance* activates the regulating power from CHPs, to minimize the real time power imbalance in the power system.

The article is organised as follows. First the dynamic power system model is described. The active power balancing models and the proposed algorithm '*rolling balance*' are then presented and explained. The performance of the *rolling balance* and the AGC is then assessed through simulations for the year 2020 with high wind penetration scenarios and the conclusive remarks are reported at the end.

2 *Dynamic power system model*

As aforementioned, the Danish power system is used to validate the performance of the *rolling balance* and the AGC. The Danish power system is composed of Eastern and Western Danish power systems, which are synchronously connected to the Nordic and Continental European (CE) synchronous power systems, respectively [8]. To study the active power balance control in the Danish power system, it requires a detailed dynamic representation of the power system that includes conventional power plants, WPPs and interconnection with neighbouring power systems. The system interconnections and the aggregated power plants models, developed in Power Factory, are explained below.

2.1 **System interconnection**

As depicted in Figure 1, the Eastern and Western Danish power systems are connected through an HVDC connection, i.e. Great Belt Link (GBL) having a transmission capacity of 600 MW. The Danish power systems are also connected to the strong neighbouring power systems of Nordic and CE, which are offering large frequency bias factor [9]. The Eastern Danish power system is synchronized with the Nordic power system through Sweden, whereas the Western Danish power system is synchronized via Germany with the CE power system. Figure 1 shows the interconnection capacities of the Danish power system with its neighbouring powers planned for the year 2020 [10]. The AC interconnection is shown as a solid line and the DC interconnection with solid line and diode symbol. In this study, the system interconnections are modelled as load where the export power can be seen as positive load and the import power as negative load. Moreover, an external grid based on the recommendation for CE and Nordic power systems is modelled to study the dynamics on AC interconnections [11] & [12].

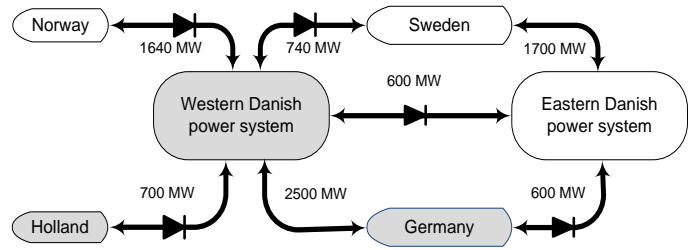

Figure 1: Danish power system interconnections

2.2 Power plants modelling

The electrical power generation in Denmark is a combination of conventional and renewable generation sources. The conventional power generation is typically from CHPs and De-centralised Combined Heat and Power Plants (DCHPs), while renewable generation is primary based on WPPs contribution. In this study, aggregated models for conventional power plants and WPPs are implemented, as they have the advantage of reduced computation effort, while still containing dynamic features relevant for long term dynamic simulation studies. These aggregated models are developed based on description found in [8] & [13, 14, 15, 16] and takes the information from HA power balancing model, *rolling balance* and the AGC for power generation set points.

a) Combined heat and power plant model (CHP)

An aggregated CHP model is developed based on studies in [13] & [14], to examine the dynamic features of a power plant in long term dynamic simulation studies, which may affect the system stability due to its slow boiler response. The response time and ramp rates associated with CHP are in order of minutes and are the dominant characteristic for power system studies.

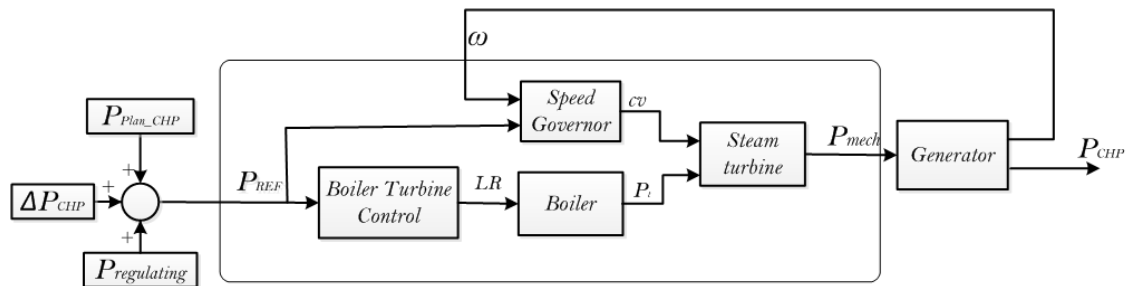

Figure 2: Aggregated CHP model

A generic diagram of an aggregated CHP model consisting of a thermal boiler, a boiler turbine controller, a steam turbine and a speed governor, is illustrated in Figure 2. The boiler model takes into

account the practical limits of the turbine output and the delays associated with the stored steam energy, while the steam turbine introduces the delays associated with the valve movement and change in the steam flow. The primary response capability is reflected through the speed governor action, which modifies the valve position of the steam turbine, according to its droop characteristic.

b) Decentralized combined heat and power plant (DCHP)

An aggregated generic model for DCHP power plant is developed for long term dynamic simulation studies based on the study in [15]. The model contains a speed governor and a gas turbine, as shown in Figure 3. The droop characteristics of the speed governor govern the primary response.

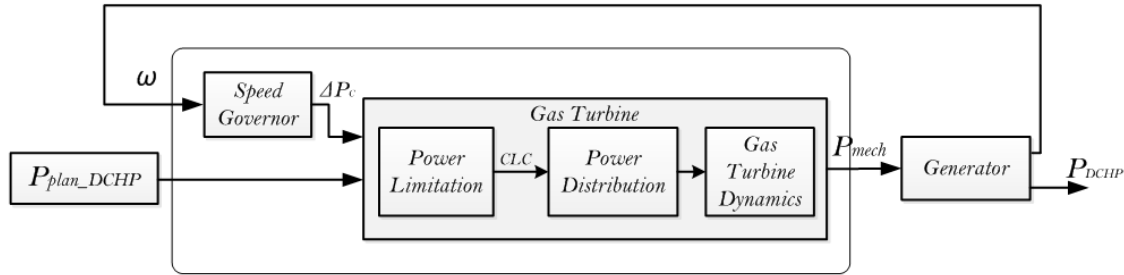

Figure 3: Aggregated DCHP model

In the gas turbine model, the power limitation block provides the physical restriction on turbine response and the excessive firing during ramping. The power distribution block represents the physical characteristics of fuel flow, air flow and allowable temperature. While, gas turbine dynamics block is included to represent the physical dynamics of combustion chambers and air compressor.

c) Wind power plant (WPP)

At the power system level, the aggregate performance of a large number of wind turbines is more important than the details of an individual wind turbine. In this study, a simplified aggregated WPP model is developed for long term dynamic simulation studies based on the IEC61400-27-1 recommendations [16], and further simplified for the secondary active power control purpose, for each part of the Danish power system.

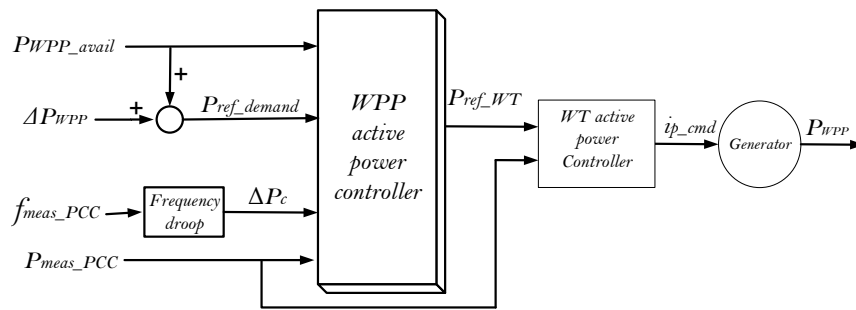

Figure 4: Aggregated WPP model

The aggregated WPP model, shown in Figure 4, has a hierarchy structure, namely that there is WPP active power control level and a wind turbine (WT) active power control level. The power reference P_{ref_WT} to the WT active power controller is generated by the WPP active power controller, based on the primary response signal (ΔP_c), the reference power signal (P_{ref_demand}) from the power balancing model and the measured power in the Point of Common Connection (PCC). The P_{ref_demand} depends on the required secondary response (ΔP_{WPP}) from the AGC and the available wind power signal (P_{WPP_avail}) from the power balancing model. The control both in the WT and in the WPP level is realised by using PI

controllers, for example, the PI controller in the WPP active power controller reduces the error between measured power at PCC (P_{meas_PCC}) and the sum between the reference power and the primary response signal (P_{ref_demand} & ΔP_c), in the decision of the P_{ref_WT} . Based on P_{ref_WT} and P_{meas_PCC} , the WT controller and generator simulates the relevant dynamic response of the WPP.

3 Power system operation

The TSOs have to maintain the active power in balance in any operating condition. They utilize and combine information from different simulation programs to ensure the power balance in power system. These programs provide information regarding wind power forecast, load demand and also simulates the regulating power plan for balanced power system. Simulation power Balancing (SimBa) is such kind of power balancing program that is used to simulate HA regulating power plan for the Danish power system [17].

As illustrated in Figure 5, SimBa uses inputs from DA market model and wind power forecast model, i.e. Wind Power Integration in Liberalised Electricity Markets (WILMAR) and Correlated Wind power fluctuations (CorWind) respectively [17]. The WILMAR provides hourly values for energy production, load and the power exchange between interconnected areas (P_{plan_DA}), while CorWind provides the DA (P_{WPP_DA}) and HA (P_{WPP_HA}) forecasts of wind power and the available wind power (P_{WPP_avail}). SimBa estimates the possible wind power schedule within the operating hour based on P_{WPP_HA} and balances the power system internally, while taking the current grid regulations and the energy market rules continuously into account. SimBa creates a list of regulating bids based on the marginal cost function, bidding price and production capacity for each unit and provides the five minute resolution plan (P_{plan_HA}) for generating units and power exchange with neighbouring power systems. It is worth mentioning that SimBa while activating the bids also takes the ramping of generating units (i.e. 30 MW/min considered in this study) and the power exchange into account. The Nordic and CE power systems ramps the agreed power exchange in 30 and 10 minutes, respectively. The power exchange starts 5 minutes and 15 minutes before the agreed exchange hour in CE power system and in the Nordic power system, respectively [18].

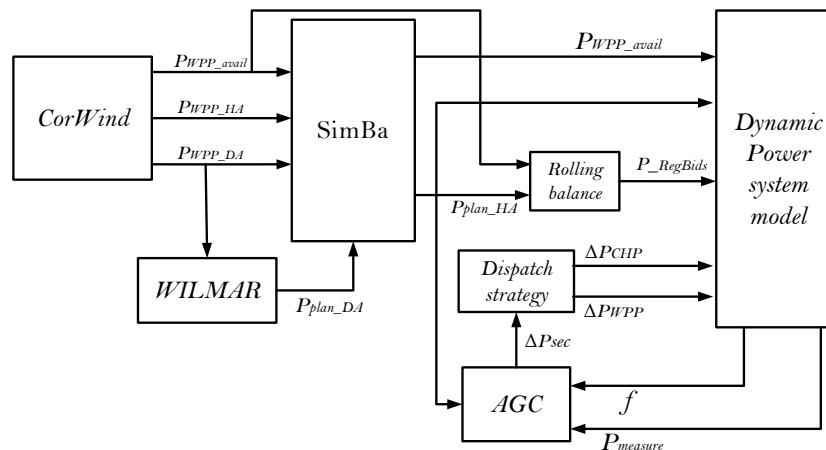

Figure 5: Overview of the signals between CorWind, WILMAR, SimBa, dynamic power system model, rolling balance, AGC and the dispatch strategy

In this study, power mismatch between generation and load appears from the HA balanced power system, if the actual wind power generated within the operating hour differs from the forecast. In order

to maintain the balance power system operation within the operating hour, the speed governors instantly provides the primary response and then the AGC along with *rolling balance* compensates the power imbalance.

3.1 Automatic Generation Control (AGC)

AGC is used to routinely balance the power system and makes its operation more reliable [18]. Traditionally conventional power plants provide the secondary frequency control in real time operation. However, the increasing wind power integration may require active participation from WPPs in secondary frequency control in future power systems along with conventional power plants, as some conventional power plants might be replaced by WPPs. Coordinated AGC with dispatch between conventional power plants and WPPs is therefore of high priority for operational security and stability.

The AGC, developed and implemented in this study, is sketched in Figure 6. The “area control error” (P_{ACE}) calculation is based on the power exchange deviation from its scheduled (ΔP) and the frequency deviation (Δf) from its nominal value, as shown in equation 1 and equation 2. The frequency bias setting ‘B’ of the AGC, in equation 1, depends on overall droop characteristics of the generating units taking part in the primary response.

$$P_{ACE} = \Delta P + (\Delta f \times B) \quad (1)$$

$$\Delta P = P_{exchange} - P_{exchange_HA} \quad (2)$$

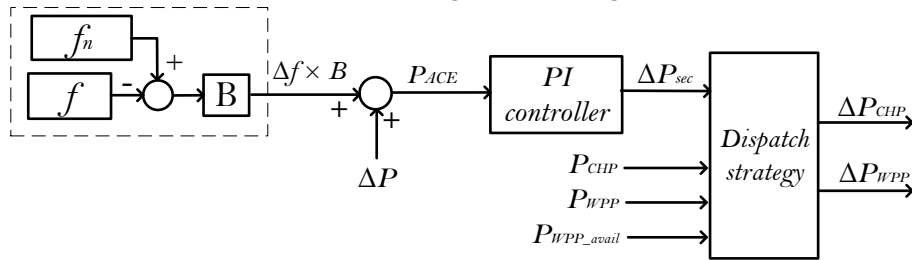

Figure 6: AGC model

The central controller, usually a proportional integral (PI), process the P_{ACE} and calculates the required change in production (ΔP_{sec}). The change in production, based on the below equation, is then distributed through ‘dispatch strategy’ block among the participating generators, i.e. CHP and WPP in this study.

$$\Delta P_{set} = -K \times P_{ACE} - \frac{1}{T} \int P_{ACE} \quad (3)$$

Unlike the traditional AGC, the coordinated dispatch between CHP and WPP is performed in this study. The dispatch is based on the assumption that the wind power is down regulated only when CHPs are unable to down regulate their production in case of generation excess, e.g. CHPs are operating on their lower generation level (20% of the online capacity) or AGC dispatch for the CHPs (ΔP_{CHP}) touches the minimum limit. Otherwise, the WPPs will generate the available wind power and only CHPs will participate in up regulation process. The ΔP_{CHP} is limited to ± 90 MW within the dispatch strategy block, as it is the case for the AGC acting on the border of Western Denmark with Germany. The WPPs will follow the AGC command to safe guard secure power system operation and if necessary will down regulate its production to the minimum operating point.

3.2 Rolling balance control

Rolling balance is designed to simulate the actions similar to the control room, to activate the regulating power bids ($P_{RegBids}$) within the real-time for balanced power system operation. The real time

power imbalance in the Eastern and Western Danish power systems is shown in Figure 7. Equation 4 calculates the power imbalance in this study, taking into account the HA schedule for conventional generation and power exchange (import and export power), available wind power generation and load demand, which is assumed to be equal to the HA forecast. However in real engineering, the control operator can estimate the load demand with very short term load forecasting technique [19] and system data from the SCADA/EMS. The operator after obtaining system data calculates the former forecasting error and then precisely estimates the load demand from the predicted load in a five minute resolution. The estimated load demand can then be used for calculating the power imbalance.

$$P_{\text{imbalance}} = P_{\text{conventional_HA}} + P_{\text{Imports_HA}} - P_{\text{Exports_HA}} + P_{\text{WPP_avail}} - P_{\text{Load}} \quad (4)$$

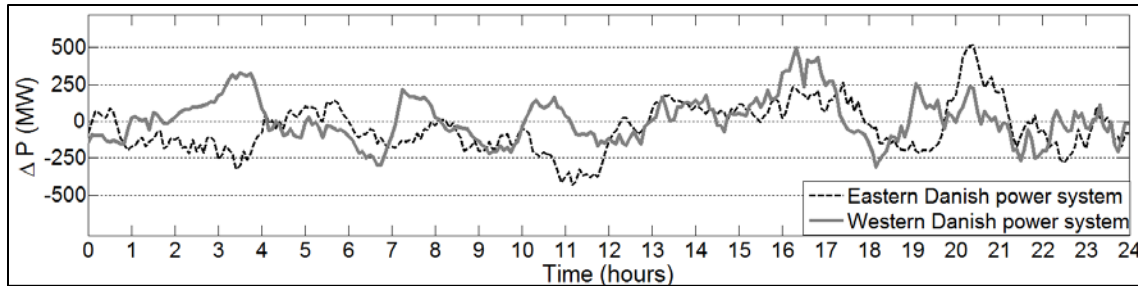

Figure 7: Power imbalance in Danish power system

The power imbalance is either caused due to forecast error (wind power/load) or other non-contingent events. In this study, the reason for power imbalance is the wind power forecast error, as illustrated in Figure 8 by comparing the power imbalance with HA wind power forecast error. The HA wind power forecast is calculated as:

$$P_{\text{HA_error}}^{\text{WPP}} = P_{\text{WPP_avail}} - P_{\text{WPP_HA}} \quad (5)$$

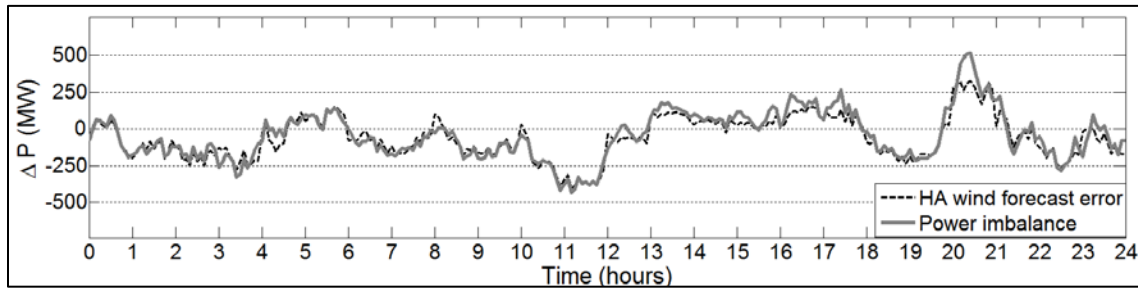

Figure 8: Power imbalance and HA wind forecast error

The *rolling balance* uses the power imbalance as an input time series and will activate the regulating bids to alleviate the imbalances as effectively as possible. Before activating the regulating bids it has to ensure that the imbalance is greater than the threshold level and persistent as well, so that the algorithm does not react excessively. In this study, if the power imbalance is greater than the 30 MW and persists for 15 minutes (i.e. three 5 minutes period), the *rolling balance* will activate the regulating bid equal to the minimum of the power imbalance in the start of third period, i.e. after the AGC response. The following rule is applied in activating the regulating bid:

$$\begin{aligned} & \text{if, } \Delta p(i) > \varepsilon \ \& \ \Delta p(i-1) > \varepsilon \ \& \ \Delta p(i-2) > \varepsilon \\ & \quad \Rightarrow \text{activate bids equal to } \min(\Delta p(i), \Delta p(i-1), \Delta p(i-2)) \\ & \text{else, } \Delta p(i) < -\varepsilon \ \& \ \Delta p(i-1) < -\varepsilon \ \& \ \Delta p(i-2) < -\varepsilon \\ & \quad \Rightarrow \text{activate bids equal to } \max(\Delta p(i), \Delta p(i-1), \Delta p(i-2)) \end{aligned}$$

where ϵ is the threshold level and $\Delta p(i)$ is the power imbalance at time period 'i'. If the imbalance in the first group of points met the aforementioned criteria, the regulating bid equal to the smallest power imbalance of the three consecutive points is activated with a ramp rate of 30 MW/min and the new points are checked. If the second group of points is also found to meet the criteria, then again the regulating bid is activated. But if one of these points does not meet the criteria, then the regulating bid is not activated. Figure 9 shows the regulating power activated in Eastern and Western Danish power systems by the *rolling balance* algorithm for an imbalance shown in Figure 7.

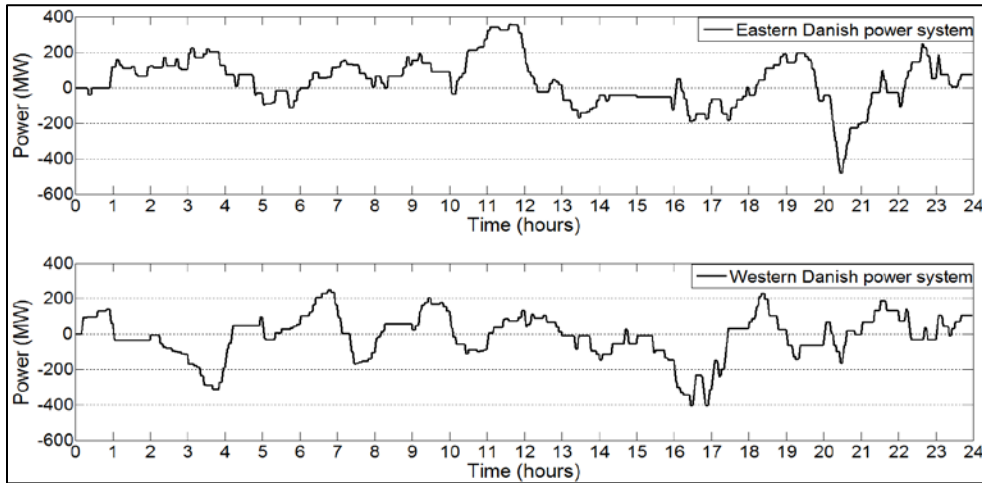

Figure 9: Regulating power activated in Eastern & Western Danish power systems

The coordination between aforementioned power balance control schemes is demonstrated in Figure 10, where primary response, AGC response and *rolling balance* are timely disassociated. Following the power imbalance, the power plants equipped with the speed governors provides the initial support by releasing the primary reserves within 30 seconds. Afterwards, the AGC provides the secondary control by ramping the power generation from the participating power plants. The response of the AGC depends on the time delays associated with the AGC system, CHP and WPP. In this study, the secondary response is provided within 7 – 8 minutes. The *rolling balance* activates the regulating power at the start of third period (10th minute), if the power imbalance is persistent for three periods and greater than threshold level. The activation of regulating power through *rolling balance* will also restores the secondary reserves, depending on the remaining power imbalance.

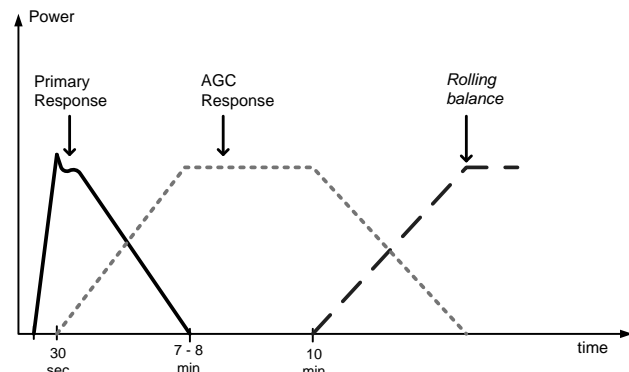

Figure 10: Proposed real-time balance control

The real-time power balancing concept provided above activates the regulating power while taking in account the maximum and minimum limits on generating units, dispatch limits and the generation cost. However, to implement the above concept, in addition to the above constraints, the coordinated AGC and *rolling balance* must also take the transmission constraints in account.

4 Simulations and Results

A set of simulations has been carried out to illustrate the performance of the power system model on the focus of active power balanced control. The simulations are performed using the time series for generation, load and power exchange generated by HA power balancing model (SimBa) for the Danish power system and are the assumptions for the year 2020 based on the real data from the year 2009. The conventional generation and the power exchange are using HA time series, while WPP generates the available wind power. Power imbalance appears within the operating hour, if HA wind power forecast is not the same as available wind power. This imbalance is compensated by AGC and by activating the regulating bids from CHPs within the operating hour by an algorithm (*rolling balance*), developed for this study.

The motivation to investigate the system behaviour on the considered day is the availability of wind power and high load demand in a large scale wind power integrated power system. The availability of wind allows the WPPs to generate more power than conventional power plants and also positive power exports with neighbouring power systems. The power exports are calculated by subtracting the total export power from total import power with neighbouring power systems. On the specific day in Eastern Denmark, the conventional power plants generated 33.31 GWh of electricity, while WPPs generated 43.2 GWh, i.e. 56.46% of the total electricity production. The high production from WPPs allows the power exports of 32.75 GWh from Eastern Danish power system, when the load demand was 43.75 GWh. Similarly in Western Denmark, 45.77 GWh is generated from conventional power plants and 59.53 GWh from WPP, i.e. 56.53%. While, the total load demand and the power exports are 63.98 GWh and 41.27 GWh, respectively. It can also be noted that on specific day, WPP contributed 98.7% and 93% of the total load demand in Eastern and Western Danish power system, respectively.

As aforementioned, the HA wind forecast error will create an imbalance between generation and load demand within the operating hour, thus deviating the system frequency from its nominal level. In response, the speed governors instantaneously release the primary reserves and balance the system frequency at new level. The deviation in frequency from its nominal level will also diverge the power exchange with from its schedule. To return the system frequency to its nominal level and power exchange to its schedule, the AGC provides the secondary response. The AGC responds to the area control error (P_{ACE}) with ΔP_{sec} and then distribute it among the participating generators through secondary dispatch block. The ΔP_{sec} lags behind ΔP_{ACE} , due to the delays in AGC system and the delays associated with the power plants response which does not allow the units to change their output as ΔP_{ACE} . These delays are due to the ramp in the reference power and also due to the slow boiler response of CHP units, as boiler needs 5 – 6 minutes to modify its output pressure when demanded.

The secondary dispatch provides new set points to the CHP and WPP, based on the operating conditions of CHP and WPP and also on the available wind power. The secondary dispatch to the CHP (ΔP_{CHP}) and WPP (ΔP_{WPP}) is shown in Figure 11, where the WPPs only participate in the down regulating process, while CHPs contributes in both up and down regulating processes. The ΔP_{CHP} is limited by ± 90 MW, as the case of AGC in Western Danish power system. The down regulating secondary dispatch to the WPPs is activated only when CHPs are unable to provide the required response, i.e. the ΔP_{CHP} reaches -90MW or they are operating at their lower limit (20% of the online capacity). The AGC controlled WPP then reduces the real time power imbalance in the Danish power system by down

regulating its production. Notice that the ΔP_{WPP} is seldom activated, only when CHP are not able to down regulate their production.

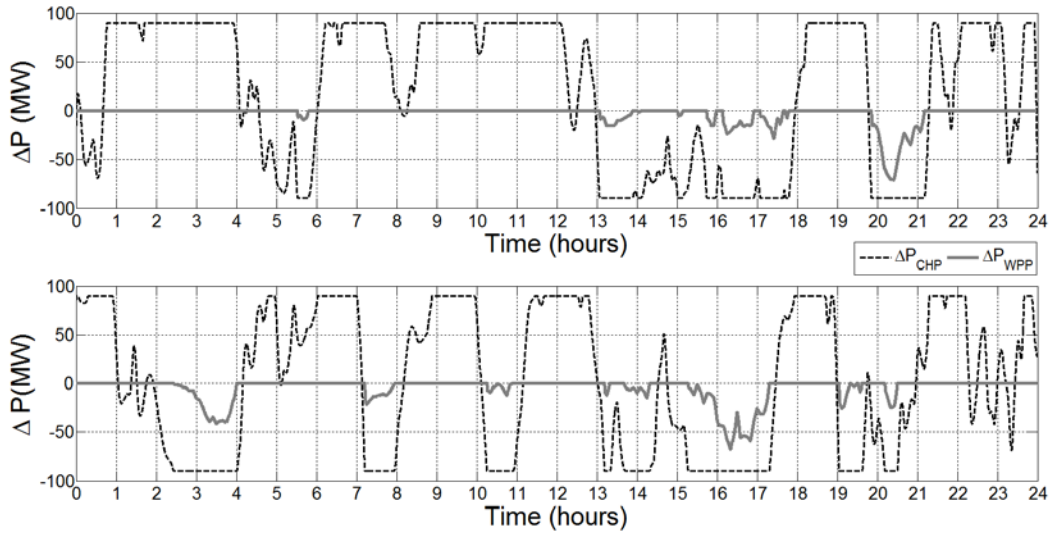

Figure 11: Secondary dispatch – Eastern Danish power system (top) & Western Danish power system (bottom)

In order to reduce the real time power imbalance and restores the secondary reserves, the *rolling balance* activates the regulating bids where the process is almost similar to the control room operator’s response. The *rolling balance* activates the bids if the imbalance is greater than threshold level (30 MW considered for this study) and persists for three periods, i.e. 15 minutes. The regulating bid is activated at the start of third period and equals to the minimum imbalance of three consecutive periods, while the AGC directly responds to the power imbalance. The regulating power activated by the *rolling balance* is already shown in Figure 9. The resulting AGC dispatch after the activation of regulating power is shown in Figure 12 and it can be noticed that the rolling balance restores some of the secondary reserves and thereby reduces the regulating burden on AGC.

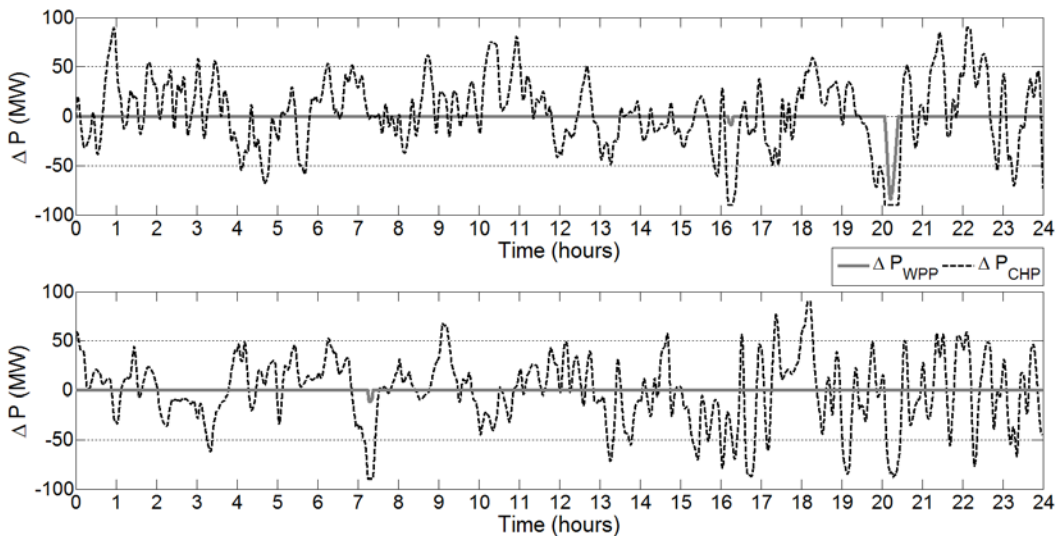

Figure 12: Secondary dispatch with rolling balance– Eastern Danish power system (top) & Western Danish power system (bottom)

Activating the regulating bids through *rolling balance* not only reduces the real time active power imbalance but makes the power system operation more reliable and secure. Figure 13 compares the power imbalance in the Danish power system, when:

- (A) – Real-time control is provided with coordinated AGC and *rolling balance*
- (B) – Real-time control is provided with coordinated AGC
- (C) – Real-time control is provided with conventional AGC, when only CHP provides support

It can be noticed that the power imbalance has decreased substantially with the proposed active power balance technique, i.e. when real-time control is provided with coordinated AGC and *rolling balance*. The conventional AGC also reduces the power imbalance in real-time, but the programmed activation of regulating bids and coordinated AGC assures the reliable operation of highly wind power integrated power system.

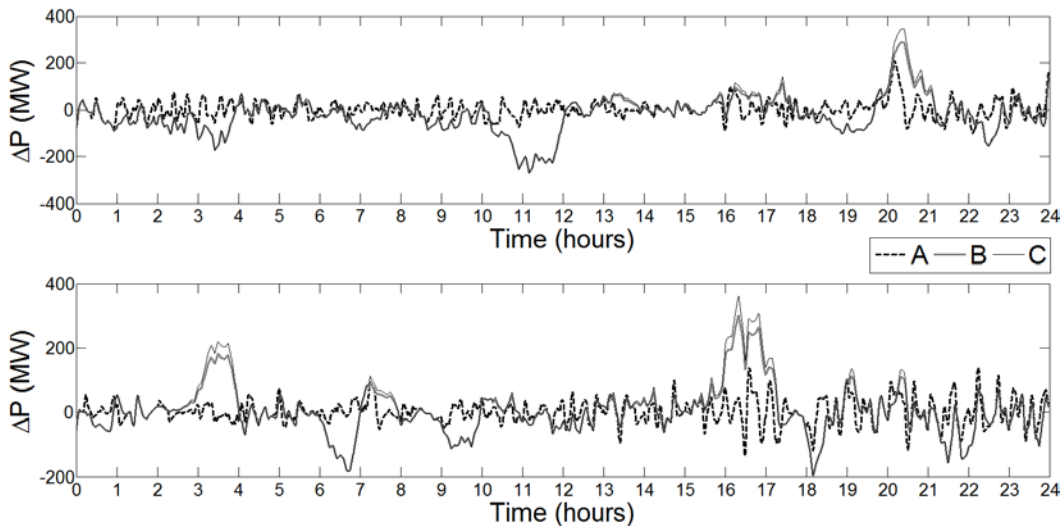

Figure 13: Power imbalance – Eastern Danish power system (top) & Western Danish power system (bottom)

5 Conclusion

Regulating power in a deregulated power system is always needed to increase system reliability and to ensure power supply security. The need for regulating reserves is growing with the increase of wind power integration in power systems. Beside this, effective way of bids activation is also of high importance. In this article, an algorithm has been designed in order to simulate the actions similar to the control room with respect to real time active power balance control. The algorithm '*rolling balance*' is exemplified and implemented for the case of a power system that reflects the dynamics of the future Danish power system with a high wind penetration scenario. The dynamic model of a power system uses input time series from an hour-ahead power balancing model (SimBa) for power generation, load demand and power exchange corresponding to one particular day with high wind speed and high load demand.

The studies performed and presented in this article illustrate how power imbalances between load and generation, caused by wind power forecast error can be compensated effectively by the automatic activation of regulating power bids from conventional power plants and also by regulating the active power production from combined heat and power plants and wind power plants. The *rolling balance* is designed to activate the regulating bids while the coordinated automatic generation control

provides the required secondary response from combined heat and power plants and wind power plants.

The importance of the regulating bids and of their effective activation for a reliable and secure operation of large wind power integrated power system has been demonstrated through the present investigation. The activation of the regulating reserves through the *rolling balance* efficiently reduces the real time imbalances and thereby ensuring reliable power system operation. Furthermore the wind power plant integrated coordinated automatic generation control ensures the secure power system operation. However, better forecasting of wind speed and the load demand is still desirable for operational security of highly wind power integrated power system.

Acknowledgement

This paper is a part of PhD project funded by Sino-Danish centre for education and research (SDC).

References

- [1] Sørensen P., Norheim I., Meibom P., Uhlen K., "Simulations of wind power integration with complementary power system planning tools," *Electric Power Systems Research*, vol. 78, no. 6, pp. 1069-1079, June 2008.
- [2] Doherty R., Mullane A., Nolan G., Burke D.J., "An assessment of the impact of wind generation on system frequency control," *IEEE Trans. on Power Systems*, vol. 25, no. 1, pp. 452 - 460, 2010.
- [3] Ummels B.C., Gibescu M., Kling W.L. and Paap G.C., "Performance of Automatic Generation Control Mechanisms with Large-Scale Wind Power," in *Nordic Wind Power Conference*, 2007.
- [4] BiHui L., Hong S., Yong T., Hongyun Z., Feng S., and Dongfu L., "Study on the frequency control method and AGC model of wind power integration based on the full dynamic process simulation program," in *International Conference on Power System Automation and Protection (APAP)*, IEEE, Beijing, 2011.
- [5] Antonishen M.P., Hai H.Y., Brekken T.K.A., Jouanne A.V., Yokochi A., Halamay D.A., Jiajia S., Naviaux D.B., Davidson J.D. and Bistrika A., "A methodology to enable wind farm participation in automatic generation control using energy storage devices," in *Power and Energy Society General Meeting*, IEEE, San Diego, CA, 2012.
- [6] Zhu J. and Cheung K., "Analysis of regulating wind power for power systems," in *Power & Energy Society General Meeting*, IEEE, Calgary, AB, 26-30 July 2009.
- [7] Vittrup C., "2013 was a record-setting year for Danish wind power," *Energinet.dk*, 15 January 2014. [Online]. Available: <http://energinet.dk/EN/El/Nyheder/Sider/2013-var-et-rekordaar-for-dansk-vindkraft.aspx>. [Accessed 06 February 2014].
- [8] Basit A., Hansen A.D., Sorensen P., "Dynamic model of frequency control in Danish power system with large scale integration of wind power," in *China Wind Power Conference*, Beijing, 2013.
- [9] Rebours Y.G., Kirschen D.S., Trotignon M. and Rossignol S., "A Survey of Frequency and Voltage Control Ancillary Services—Part I: Technical Features," *IEEE TRANSACTIONS ON POWER SYSTEMS*, vol. 22, no. 1, pp. 350 - 357, FEBRUARY 2007.
- [10] *Energinet.dk*, "Electricity interconnections," *Energinet.dk*, 10 April 2012. [Online]. Available: www.energinet.dk/EN/ANLAEG-OG-PROJEKTER/Generelt-om-elanlaeg/Sider/Elforbindelser-til-udlandet.aspx. [Accessed September 2013].
- [11] UCTE, "Policy 1: Load-Frequency Control," *ENTSO-E*, 2009.

- [12] Norheim I, Lindgren E, Uski S, Sorensen P, Jauch C , “WILMAR WP5-Deliverable D5.1, System Stability Analysis,” SINTEF, 2005.
- [13] IEEE Committee Report, “Dynamic models for fossil fueled steam units in power system studies,” IEEE Transaction on Power Systems, vol. 6, no. 2, pp. 753-761, May 1991.
- [14] Byerly R., “Dynamic models for steam and hydro turbines in power system studies,” IEEE Transactions on Power Apparatus and Systems, pp. 1904-1915, 1973.
- [15] CIGRE Task Force 25 of Advisory Group 02 of Study Committee C4, “Modeling of Gas Turbines and Steam Turbines in Combined Cycle Power Plants,” CIGRE, 2003.
- [16] IEC 61400-27 Committee Draft, Wind Turbines Part 27-1, “Electrical simulation models for wind power generation Wind turbines,” IEC Std. committee Draft (CD) 88/424/CD, 2012.
- [17] Giannopoulos G., Frequency control in area with large scale wind power, Roskilde: Denmark Technical University, 2012.
- [18] ENTSO-E, “Continental Europe Operation Handbook – p1: LOAD-FREQUENCY CONTROL AND PERFORMANCE,” [Online]. Available: <https://www.entsoe.eu/publications/system-operations-reports/operation-handbook/>. [Accessed September 2013].
- [19] Liu K., Subbarayan S., Shoults R.R., Manry M.T., Kwan C., Lewis F.L., Naccarino J., “Comparison of very short-term load forecasting techniques,” IEEE Transactions Power Systems, vol. 11, pp. 887,882, 1996.

P4: Basit A.; Hansen A. D.; Altin M.; Sørensen P.: "Analysis of Highly Wind Power Integrated Power System model performance during Critical Weather conditions", Wind Integration Workshop (WIW), Berlin, 2014

Analysis of Highly Wind Power Integrated Power System model performance during Critical Weather conditions

Abdul Basit
DTU wind energy
Technical University of Denmark
Denmark
Sino-Danish Centre for Education and Research (SDC)
Denmark

Anca D. Hansen
Poul E. Sørensen
Mufit Altin
DTU wind energy
Technical University of Denmark
Denmark

Abstract – Secure power system operation of a highly wind power integrated power system is always at risk during critical weather conditions, e.g. in extreme high winds. The risk is even higher when 50% of the total electricity consumption has to be supplied by wind power, as the case for the future Danish power system in 2020. This paper analyses and compares the performance of the future Danish power system during extreme wind speeds, where wind power plants are either controlled through a traditional High Wind Shut Down storm controller or a new High Wind Extended Production storm controller. For this purpose, the power system model has been developed that represents the relevant dynamic features of power plants and compensates for power imbalances caused by the forecasting error during critical weather conditions. The regulating power plan, as an input time series for the developed power system model, is provided by the hour-ahead power balancing model, i.e. Simulation power Balancing model (SimBa). The regulating power plan is prepared from day-ahead power production plan and hour-ahead wind power forecast. The wind power (forecasts and available) are provided by the Correlated Wind power fluctuations (CorWind) model, where the wind turbine storm controllers are also implemented.

Keywords – Wind Power Plants (WPPs); Automatic Generation Control (AGC); Power balance control; High Wind Shut Down (HWSD); High Wind Extended Production (HWEP)

I. Introduction

High wind power integration influences the technical operation of a power system, particularly the active power balance control between generation and demand during extreme high wind speeds. It can result in a significant loss of wind power in very short time (minutes) [1], instigating the power imbalance in the power system. With increasing wind power integration, the situation is even more alarming for future power system, e.g. the case of Danish power system in 2020, where 50% of the total electricity production has to be supplied by wind power [2]. Therefore, while planning the power balancing operation of a large scale wind power integrated power system; the variable wind power generation must be taken in account along with the technical capabilities of the generating units.

The wind turbine is normally equipped with High Wind Shut Down (HWSD) storm controller to safeguard turbine from mechanical breakdown during extreme winds. The HWSD controller halts wind turbines from operation if wind speed increases than 25 m/s [3]. However in similar circumstances, the wind turbine equipped with the new High Wind Extended Production (HWEP) storm controller will gradually reduce their power output [3], providing a positive impact on the power system balance without effecting the turbines structural integrity. This study analyses the impact of HWSD or HWEP storm controller on active power balance control in future Western Danish power system model.

The Western Danish power system model with high wind power penetration is developed in this study, taking the generation and power exchange capacities for the year 2020 into account [4]. The implemented power system model includes models for the centralised or De-centralised Combined Heat and Power plants (CHPs or DCHPs), Wind Power Plants (WPPs), interconnections with neighbouring power system and coordinated Automatic Generation Control (AGC) system between CHPs and WPPs. The performance of the developed power system model during extreme wind conditions is assessed and discussed by means of set of simulations, where hour-ahead generation schedules in a time scale of five minutes, generated by Simulation power Balancing (SimBa) model, are used as inputs. The conventional generation and the power exchange are using hour-ahead time series, while WPPs generate the available wind power. SimBa, developed by the Danish TSO Energinet.dk together with the Technical University of Denmark, releases an hour-ahead regulating power plan based on day-ahead power production plan and hour-ahead wind power forecast [4]. The hour-ahead forecast and the available wind power are provided by the Correlated Wind power fluctuations (CorWind) model, where the wind turbine storm controllers (HWSD and HWEP) are implemented.

The article is structured as follows. A brief description of the storm controllers, i.e. HWSD and HWEPE is initially provided. Then the proposed active power balance control methodology is described, approaching also the aspects regarding the generation of the hour-ahead (HA) regulating power plan and the AGC. The extreme high wind speed scenarios for the Western Danish power system in year 2020 are used to analyse the active power balance control through a set of simulations with the developed Danish power system model. Finally, conclusive remarks are reported in the final section.

II. Storm Controller

The storm controller ceases power generation from wind turbines during critical weather conditions, to prevent turbine from damage due to extreme mechanical loads. The typical storm controller (HWSD) halts the wind turbine from operation, when wind speed reaches 25 m/s. However, the HWRD functionality enables wind turbines to operate at higher wind speeds with reduced power output, without affecting the structural integrity of the turbine. These storm controllers are briefly described below:

A. High Wind Shut-Down (HWSD)

HWSD is the typical storm controller installed in majority of the wind turbines. The HWSD controller halts the turbine operation when average wind speed reaches to a certain level. The average wind speed is based on 1 second, 30 seconds and 10 minutes. The HWSD behaviour is described by the power curve presented in Figure 1. The sudden cut off may result in active power balance/frequency control issues on power system level, depending on the wind power integration in the power system.

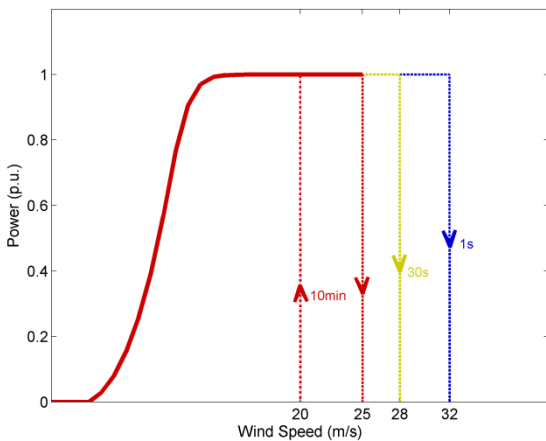

Figure 1: HWSD – wind power curve

B. High Wind Extended Production (HWEPE)

At higher wind speeds, the HWEPE allows production from wind turbine by de-rating the power and speed regularly as a function of wind speed, without impacting the structural integrity of the turbine [3]. The power curve depicting the behaviour of HWEPE controller is shown in Figure 2.

The HWEPE controls generation from wind turbine in two modes, that acts parallel and aren't directly dependent on one another [1]. First operational mode reduces the turbine rotational speed based on the rotor acceleration, by converting the current rotor speed to absolute acceleration. The acceleration value with a gain limits the turbine rotational speed proportional to the increase in wind speed and the turbulence intensity. To avoid high torque on the rotor due to reduction in speed, the power output from the wind turbine is also reduced. In second operational mode, the power output is reduced by controlling the pitch angle. The pitch angle increases as a function of wind speed increase and thus result in a gradual power reduction. Bias values for pitch and rotor acceleration are also assigned with the activation of HWEPE to allow smoother transition in power and speed, rather than a sudden step change.

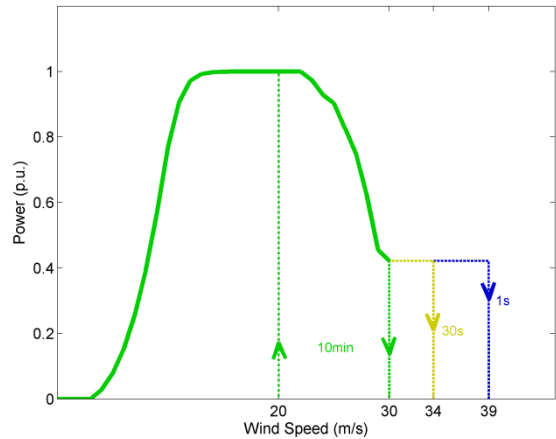

Figure 2 HWEPE – wind power curve

The wind turbine starts again to operate, when the average wind speed drops below certain value. To prevent frequent restarts and shutdowns, the turbine is connected only when the average wind speed reaches to 20 m/s, as shown in Figure 1 and Figure 2.

In this study, HWSD and HWEPE controllers were implemented in CorWind model, to analyse the dynamic behaviour of Danish power system model during high wind speeds.

III. Power balance control

TSOs securely operate the power system in maintaining the active power balance in the power system. In deregulated power systems, the balance is maintained through electricity markets by the balance responsible companies, who can produce, consume or retail. The examples of electricity markets are the day-ahead (DA), hour-ahead (HA) and regulating power markets, where dispatch bids are selected with foremost intent of preserving system integrity and to minimize the production cost. Subsequent to DA market, the HA market modifies the DA dispatch bids before the actual operation period, taking in account the updated wind power forecasts or unavailability of power plants. However in real-time operation, the wind power may be different from the HA forecast, which can lead to active power imbalance in the power system. This power imbalance is then compensated through regulating reserves in the real-time.

In this study, the real time imbalance is caused due to the forecasting error during critical weather conditions and the imbalance is compensated through automatic reserves, i.e. with AGC, when WPPs are equipped with either HWSO or HWEF storm controllers. The following subsections will explain the power balancing model with the generation of HA regulating power plan for the power plants and power exchange with neighbouring power systems and the real time power balance control in the power system with the coordinated AGC dispatch between CHPs and WPPs.

A. Hour-ahead power balance control

SimBa, the HA power balancing model, simulate the regulating power plan to ensure the active power balance control in the power system. It uses data input time series from DA market model and HA forecast of wind power to generate regulating power plan for the intra-hour balance with five minute resolution. The DA time series (P_{plan_DA}) are provided by Wind Power Integration in Liberalised Electricity Market (WILMAR), while the Correlated Wind power fluctuations (CorWind) model provides the HA forecast of wind power (P_{WPP_HA}), as shown in Figure 3. The CorWind model also provides the DA forecast of wind power (P_{WPP_DA}) and the available wind power (P_{WPP_avail}). As aforementioned, for the analysis presented in this paper, the storm controllers were implemented in CorWind model to provide P_{WPP_avail} during extreme high wind speeds.

SimBa models the power system taking into account the current grid regulations and the electricity market rules. SimBa uses inputs from WILMAR that include hourly

values for energy production, load and the power exchange between interconnected areas and HA wind power forecasts from CorWind. Based on these inputs, SimBa balances the power system and provides HA five minutes period plan for generating plants and power exchange with neighboring power systems, i.e. P_{plan_HA} .

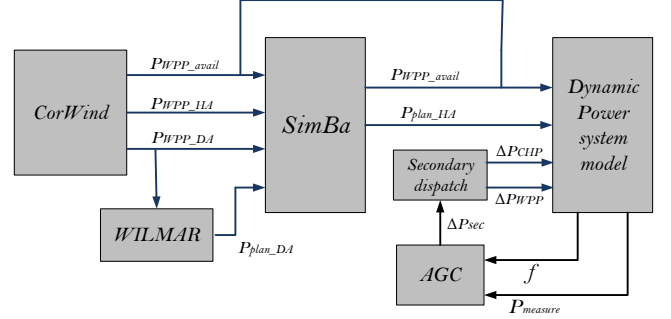

Figure 3: Overview of the signals between CorWind, WILMAR, SimBa, the power system model and the AGC.

During real-time, the power system can come out of balance, if available wind power is not the same as HA forecast. The active power balance is then controlled through activation of regulating bids from the Nordic Operational Information System (NOIS) list in the TSO's control room and also through AGC with a reserved capacity of ± 90 MW, acting on the border of Western Denmark with Germany. However, for the present investigation, it is assumed that the power imbalance is controlled only through AGC.

B. Automatic generation control (AGC)

AGC developed and implemented in this investigation is sketched in Figure 4. It measures the frequency deviation (Δf) from its nominal level and the possible power mismatch (ΔP) between generations (CHPs, DCHPs, and WPPs) and power exchange with neighbouring power systems and system load, as shown in Equation 1. The sum of ΔP with the product of Δf and system frequency bias factor (B) is called the ‘‘area control error’’. B is determined from the droop characteristics of all generating units taking part in the primary response [5]. The area control error (ΔP_{ACE}) is processed by a central controller, usually a PI, which calculates the required change in production (ΔP_{sec}) for the power plants to bring the ΔP_{ACE} to zero (Equation 2).

$$\Delta P = P_{Load} + P_{exchange} - P_G \quad (1)$$

$$P_{ACE} = \Delta P + (\Delta f \times B) \quad (2)$$

As indicated in Figure 4, the change in production ΔP_{sec} is then distributed using the ‘dispatch strategy’ block among the actively participating generators, namely CHPs and WPPs assumed in this study. The dispatch decides the

change in reference power for the participating generating units, i.e. ΔP_{CHP} and ΔP_{WPP} , by using as inputs ΔP_{sec} signal, CHPs power generation (P_{CHP}), WPPs power generation (P_{WPP}) and the available wind power ($P_{\text{WPP_avail}}$) [4].

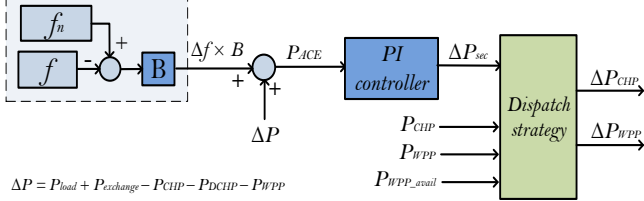

Figure 4: AGC and dispatch strategy model

The dispatch strategy decides the delta set-points for the participating generating units as follows: the WPP is down regulated only when the output of AGC is negative, i.e. $\Delta P_{\text{sec}} < 0$, while the CHP provide secondary responses for positive or negative value of ΔP_{sec} . For down regulation, the WPP will receive reference power signal only when CHP generation touches the lower generation limit or ΔP_{sec} reaches to $\Delta P_{\text{CHP_LowLim}}$, i.e. -90 MW. However, in case of up regulation, i.e. $\Delta P_{\text{sec}} > 0$, only the CHP provides the secondary support, as the WPP is already generating the available wind power.

IV. Power system model

As aforementioned, the future Western Danish power system model is used to study the power balance control during extreme high wind speeds, where generation from WPPs under these conditions are either controlled through HWSD or HWEP storm controllers. This study requires a detailed dynamic representation of the power system that includes conventional power plants, WPPs and the interconnection with neighbouring power systems. The system interconnections and the aggregated power plants models, developed in Power Factory, are explained below.

A. System interconnections

The Western Danish power system is synchronously connected to the strong CE power, via Germany, which offers huge frequency bias. The Western Denmark is also connects to the Nordel power system via HVDC link, i.e. Eastern Denmark, Norway and Sweden. However, there are plans to increase the AC interconnection capacity with Germany and HVDC interconnection capacity with Norway and also to build new HVDC link with Holland [4]. The system interconnections are modelled as simple load accompanied by an external grid, which shows the deviations on AC link in case of power imbalance. The external grid offers the frequency bias and the inertia of the synchronous power system.

B. Power plants modelling

The electrical power generation in Denmark is a combination of conventional and renewable generation sources, where conventional power generation is typically from CHPs and DCHPs and renewable generation is primary based on WPPs contribution. In this study, the aggregated models for these power plants are developed having advantage of a reduced computation effort while maintaining the dynamic features relevant for long term dynamic simulation studies. The power system model developed for this study is based on the description presented in [6 – 9]

Aggregated CHP model reflects the slow boiler response of the thermal power plant [6 – 7]. The boiler and steam turbine response of the CHP is the dominant characteristic for active power balance control in power system studies and can affect the power system stability. Correspondingly, aggregated model for DCHP considers the dynamics of gas turbine [8] and aggregated WPP model takes in account the active power response from the WPPs [9]. SimBa and the AGC provide the power set points for these power plants.

V. Simulation results

A set of simulations are performed using time series for generation, load and power exchange corresponding to a scenario with extreme high wind speeds. The time series are generated by SimBa for the future Danish power system (2020) based on the real data from the year 2009 (October 3 20:00 – October 4 12:00).

The electricity market balances the Danish power system taking in account the HA wind power forecasts. The power system comes out of balance if the available wind power generated within the operating hour differs from the HA forecast. The power imbalance yields to a change in the system frequency and deviation in power exchange from HA schedule. The power imbalance is worse if the forecasting error leads to wind turbine cut off (during storms). Figure 5 shows the real-time power generation from the WPPs during high wind speeds, when conventional storm controller (HWSD) or new storm controller (HWEP) is in operation.

During initial period, the HWSD controller ceases operation from number of wind turbine due to extreme high wind speeds, resulting in a high power imbalance from the HA balance plan, as shown in Figure 6. However, in similar circumstances, the HWEP while safeguarding the turbines structural integrity only deregulates the production from wind turbines, thereby resulting in lower forecasting error and lower power imbalance.

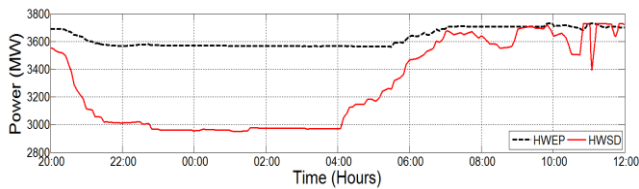

Figure 5: Wind power production – HWEP & HWSD

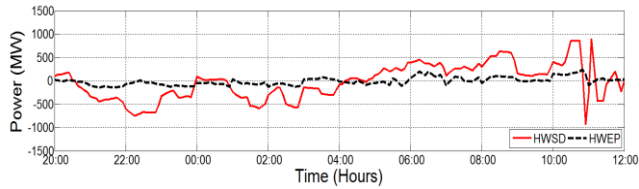

Figure 6: Power imbalance due to HA forecast error

The generating unit instantly responds to the power imbalance by releasing primary reserves. Afterwards, the AGC response reduces the power imbalance in the power system by providing new set points to the participating generating units, i.e. CHP and WPP. The decrease in the power imbalance depends on the reserves availability. The dispatch strategy block in Figure 4 determines the change in reference power set points for CHP (ΔP_{CHP}) and WPP (ΔP_{WPP}). As aforementioned, the WPP only participate in the down regulating process, while CHP contributes in both up and down regulating processes. Also, the ΔP_{WPP} is activated only when CHP are unable to provide the required response, namely that when the ΔP_{CHP} touches the lower limit (-90 MW) or they are operating at their lower generation limit (20% of the online capacity). The delay in overall secondary response will be due to the AGC response, reference power ramp rate (i.e. 30 MW/min considered in this study) and slow boiler response of CHP units, as boiler needs 5 – 6 minutes to modify its output pressure when demanded.

Figure 7 shows the secondary dispatch power for the CHP and WPP, while Figure 8 shows the residual power imbalance after secondary response, when HWSD or HWEP is in operation. During initial operation period (20:00 – 04:30), the high wind speed results in cutting off wind turbines by the HWSD controller and thus large negative power imbalance. The AGC responds to this power imbalance by regulating the reserves from the CHP; however, the power imbalance couldn't be reduced further as the dispatch is limited by +90 MW. In the same operational period, the WPPs couldn't provide any support as they are already generating the maximum possible power. In similar circumstances, the HWEP only reduces the power generation from the wind turbine and thus results in a lower power imbalance which can be compensated by AGC, as shown in Figure 7 and Figure 8.

In later period, the wind turbines again start producing the available wind power, as the average wind speed reduces consequently resulting in generation excess from the HA balance plan. The imbalance is then reduced by manoeuvring the generation from CHPs and WPPs through AGC. The imbalance is high again in case of HWSD controllers, as wind turbines previously taken out of operation starts generating the available wind power.

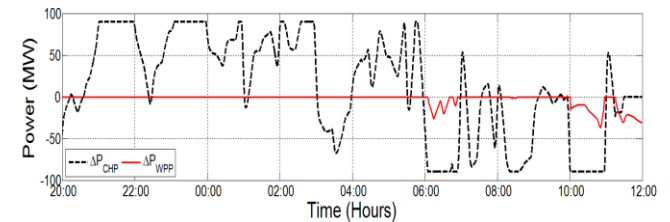
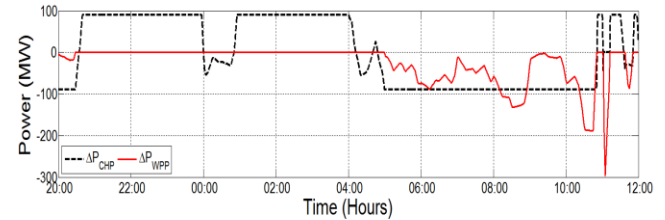

Figure 7: AGC dispatch; top:HWSD, bottom:HWSD

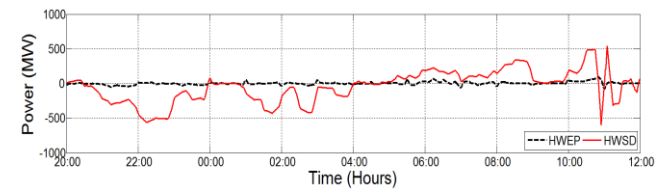

Figure 8: Power deviation after Secondary Response

VI. Conclusion

Large scale integration of wind power challenges the reliable operation of power system, especially during critical weather condition, e.g. extreme high wind speeds. If not forecasted, these conditions may result in a high power imbalance especially for the wind turbines equipped with High Wind Shut Down storm controllers. During extreme high wind speeds, the High Wind Shut Down ceases power generation from wind turbines for their mechanical safety. Analogously, the wind turbine with High Wind Extended Production will only de-rate their generation, thus safeguarding their structural integrity and resulting in less power imbalance during real-time.

This study analyses the active power balance control in future Western Danish power system during extreme high wind speeds, when WPPs are either controlled with High Wind Shut Down storm controller or High Wind Extended Production storm controller. From the results, it can be concluded that High Wind Shut Down results in high power imbalances which can't be fully compensated with primary

and secondary reserves, and therefore residual power imbalance can affect the reliable system operation. However, controlling the wind turbines with High Wind Extended Production will result in less power imbalance and thus assures safe operation of the power system during critical weather conditions.

VII. Acknowledgement

This paper is a part of PhD project funded by Sino-Danish centre for education and research (SDC).

VIII. References

- [1] Cutululis NA, Litong-Palima M, Sørensen PE, Bjerger, MH & Detlefsen, N, "Impact of High Wind Speed Shut-down in the Danish Power System," in 12th International Workshop on Large-Scale Integration of Wind Power into Power Systems as well as on Transmission Networks for Offshore Wind Power (WIW 2013), 2013.
- [2] Vittrup C, "2013 was a record-setting year for Danish wind power," Energinet.dk, 2014.
- [3] Cutululis NA, Litong-Palima M, Sørensen PE, "Offshore Wind Power Production in Critical Weather Conditions," in Proceedings of EWEA 2012 - European Wind Energy Conference & Exhibition. European Wind Energy Association (EWEA), 2012
- [4] Basit A; Hansen AD, Altin M, Sørensen P, Gamst M, "Wind power integration into the automatic generation control of power systems with Large-scale wind power," IET - JoE, 2014.
- [5] Prabha K, Power System Stability and Control, McGraw-Hill, 1994.
- [6] I.C. Report, "Dynamic Models for Steam and Hydro Turbines in Power System Studies," IEEE Transactions on Power Apparatus and Systems, Vols. PAS-92, no. 6, pp. 1904-1915, November 1973.
- [7] IEEE Committee Report, "Dynamic models for fossil fueled steam units in power system studies," IEEE Transaction on Power Systems, vol. 6, no. 2, pp. 753-761, May 1991.
- [8] CIGRE Task Force 25 of Advisory Group 02 of Study Committee C4, "Modeling of Gas Turbines and Steam Turbines in Combined Cycle Power Plants," CIGRE, 2003.
- [9] IEC 61400-27 Committee Draft, Wind Turbines Part 27-1, "Electrical simulation models for wind power generation Wind turbines," IEC Std. committee Draft (CD) 88/424/CD, 2012.

P5: Basit A.; Hansen A. D.; Altin M.; Sørensen P.: “Balancing modern Power System with large scale of wind power”, China Wind Power (CWP), Beijing, 2014

Balancing modern Power System with large scale of wind power

A. Basit^{1,*§}, M. Altin^{*}, A.D. Hansen^{*} and P. Sørensen^{*}

^{*} Technical University of Denmark, Department of Wind Energy, Frederiksborgvej 399, Building 125, 4000 Roskilde, Denmark

[§] Sino-Danish Center for Education and Research, Niels Jensens Vej 2, 8000 Aarhus, Denmark

Abstract – Power system operators must ensure robust, secure and reliable power system operation even with a large scale integration of wind power. Electricity generated from the intermittent wind in large proportion may impact on the control of power system balance and thus deviations in the power system frequency in small or islanded power systems or tie line power flows in interconnected power systems. Therefore, the large scale integration of wind power into the power system strongly concerns the secure and stable grid operation. To ensure the stable power system operation, the evolving power system has to be analysed with improved analytical tools and techniques. This paper proposes techniques for the active power balance control in future power systems with the large scale wind power integration, where power balancing model provides the hour-ahead dispatch plan with reduced planning horizon and the real time imbalances are minimized with automatic generation controller and the programmed to regulate active power reserves.

Keywords – Power balance control, Large scale wind power integration, AGC and Inaccurate wind forecast

1 Introduction

Electricity generation from wind power has increased significantly during the last decade. Wind power is increasingly being viewed as a mainstream electricity supply technology as it has very low CO₂ lifetime emission, significantly exploitable resource potential, no cost uncertainties from fuel supply price fluctuations, can be rapidly installed and opportunities for industrial, economic and rural development. Therefore, globally 318 GW of wind power capacity has been installed till the end of 2013, where 35 GW was only installed in 2013 [1]. China holds the largest capacity of wind power plants worldwide with 91.4 GW of installed wind power. Other countries having large wind power capacities are United States (61 GW), Germany (34.2 GW), Spain (22.95 GW) and India (20.15 GW) [1].

Denmark being the pioneer of electricity generation from wind power is among the top 10 countries having the largest wind power capacity. It has worldwide the highest wind power penetration level with respect to the total generation, with the generating capacity of 4.79 GW [2]. The installed wind power generated 11.1 TWh during the year 2013 and shares 33.2% of the electricity generation in the entire year, when the total electricity generation in the Danish grid was 33.5 TWh [2].

In the future, these levels are expected to be increased according to the political and environmental policies. Therefore, large scale integration of wind power into the power system may risk the secure and stable grid operation without consideration of the wind variability. The problems that need to be addressed include frequency control, power balance control, voltage stability, reserves and transmission capacity [3]. Frequency control problems are more prominent in small and islanded power systems. Accordingly, in a large interconnected power system, such as Denmark connected to European power system, power balance is one of the main challenges that need to be evaluated for large scale integration of wind power. Wind power forecast contributes considerably to the power balance control, as the inaccurate wind forecast disrupts the cost effective generation schedule and could reduce system stability. The system operators concerns on how to integrate a significant amount of this intermittent wind power without disrupting the power system balance control.

¹Corresponding author: Tel.: +45 2492 1623; Fax: +45 4677 5083; E-mail address: abdl@dtu.dk (A. Basit)

The paper presents a platform for the active power balance control in a large scale wind power integrated power system. This methodology consists of a dynamic power system model implemented in Powerfactory DigSilent with hour-ahead active power set values for the conventional generation and consumption, and the forecasted wind power from Simulation power Balancing (SimBa) tool. Consequently, the simulation results will be presented for an example of Danish power system as a benchmark of the proposed platform. A dynamic power system model for long term dynamic simulations studies has been developed, representing relevant dynamic features of the power plants and compensates for imbalances between load and generation by regulating the active power production in real time. The present developed power system model includes models for the Automatic Generation Control (AGC) system, centralised or de-centralised Combined Heat and Power plant (CHP and DCHP), Wind Power Plant (WPP) and interconnections with neighbouring power systems. The highly wind power integrated power system model is using hour-ahead schedule information on power generation, power demand and power exchange as input, with five minute dispatch plan. The hour-ahead plan is generated by SimBa model, developed by the Danish TSO (Energinet) together with the Technical University of Denmark.

The paper is structure as follows; a brief description of the impact of inaccurate wind power forecast in a highly wind power integrated power system is provided in Section II. The implemented power system model with high share of wind power is then described in Section III, while power balancing techniques and simulation results are shown and analysed in Section IV. Finally, Section V draws the partial conclusions of this study.

2 Impact of inaccurate wind power forecast

Power system must keep the supply and demand power in close balance at all times. In traditional power systems, the average load almost varies in predictable patterns, except for the unforeseen events. These variations are compensated in real time through additional generation capacity kept as reserves. Introducing wind generation can increase the regulation burden and need for reserves, due to its natural intermittency. Wind power impacts the reliable power system operation and it depends on their penetration level, and also on the power system size, generation capacity mix, load variation and the interconnection with neighbouring power systems. The intermittent nature of wind power may lead to a power balancing problems in a highly wind power integrated power system can deviate the system frequency from its nominal level and the tie line power exchange from planned and cost effective generation schedule. The large scale integration of wind power therefore challenges the system operators to maintain a close balance between production and consumption in their individual power systems and the tie line interchange at its schedule.

Wind power forecast plays an important role in this regard, as for example. in a current Danish power system, a single m/s increase or decrease in a wind speed between 5 – 15 m/s will generate a power imbalance of approximate 350 MW [4]. The developed control methods and the available reserves are suitable to deal with the variable wind power supply in the existing power systems. However, operation and control methods need to be reviewed for future integration of wind power as wind power plants will be replacing the conventional power plants in modern power system.

3 Power system modelling

Power system model has been developed to study the active power balance control in a modern power system with high wind power penetration level, where more than 50% of the electricity is generated by the wind power. The developed power system model reflects the most relevant dynamics of the power system with respect to active power balancing control issues. It includes the AGC system, aggregated models for the CHP, DCHP and WPP and the interconnections with neighbouring power system, as shown in Figure 1.

The response time and ramp rates associated with CHP and DCHP models are in order of minutes and are the dominant characteristic for power system studies. An aggregated CHP model consists of a thermal boiler, a boiler turbine controller, a steam turbine and a speed governor, while, an aggregated DCHP model includes gas turbine and a speed governor. The speed governor of the generating units activates the primary reserves, i.e. Frequency Containment Reserves (FCR), if the frequency deviates by ± 0.01 Hz. The amount of FCR depends on the droop characteristic of the governor of each generating unit (i.e. 4% in this study) and the available capacity. The reference power signal for the conventional generating units is calculated from the hour-ahead schedule generated by SimBa and the power correction from the AGC, i.e. Frequency Restoration Reserves (FRR). The CHP power plant also activates the regulating reserves, i.e. Replacement Reserves (RR), to reduce the real time imbalance in the power system.

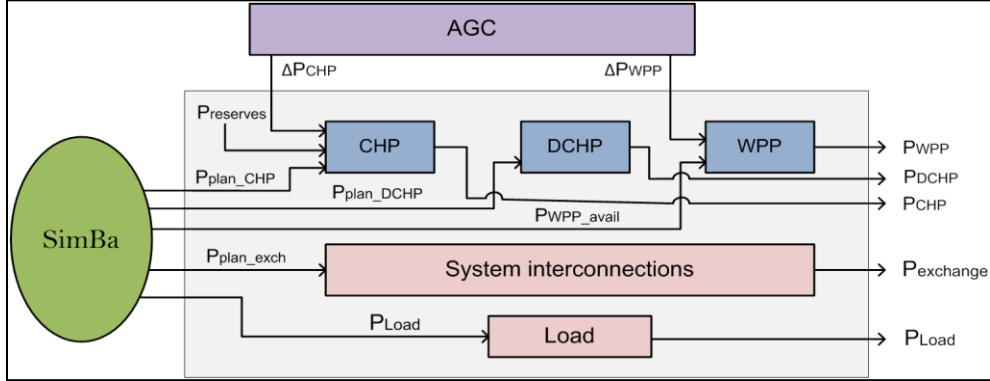

Figure 1: Power system model

An aggregated WPP model is also modelled for the active power control purpose, where the power reference is decided based on the available wind power, primary response and the secondary response from an AGC.

4 Techniques for balancing power system operation

In deregulated power systems, the electricity is traded in electricity markets by the balance responsible companies that can produce, consume or retail. The balance responsible balances the power system for every operating period to one hour in advance of the actual operation hour. The unpredictable wind nature or other non-contingent events might create power imbalance within the actual operating hour. These imbalances are then minimized in real time by primary and secondary responses and also by activating the reserve power, within minutes, from regulating power market.

To study the power system balance operation with large scale of wind power, a specific day is considered when conventional power plants generated 33.15 GWh of electricity, while wind power generated 43.22 GWh, i.e. 56.59% of the total electricity production, with total load demand of 43.76 GWh. The hour-ahead balance power schedule is provided by SimBa and the real time imbalances are compensated by varying the production from CHP and WPP using an AGC and also by programmed control of regulating reserves.

4.1 Hour-head balancing operation

Conventional market models are simulating optimal unit commitment and dispatch of generation units with one hour resolution, based on input time series for consumption and renewable power generation [5]. However to cope with the inaccurate wind power forecast in a highly wind power integrated power system, it is needed to activate the dispatch power with reduced planning horizon in order to decrease the real time regulating burden. SimBa releases an hour-ahead dispatch plan in a time scale of five minutes to manage the power imbalances in a highly wind power integrated power system. It takes hour-ahead wind power forecasts, estimates the wind power fluctuation within each operating hour and calculates the available wind power with a five minute

time resolution. Based on the simulated hour-ahead wind power forecast and the day-ahead power production plan from the spot market, it provides dispatch plan for generating units and power exchange with neighbouring power system. However due to the uncertain nature of wind, the wind power within the operating hour may not be the same as its estimated value and this aspect can create power imbalance within the operating hour. The amount of power imbalance seen by the developed power system model in this study, using hour-ahead schedule from SimBa, is shown in Figure 2. The figure also shows the hour-ahead wind power forecast error during the same period.

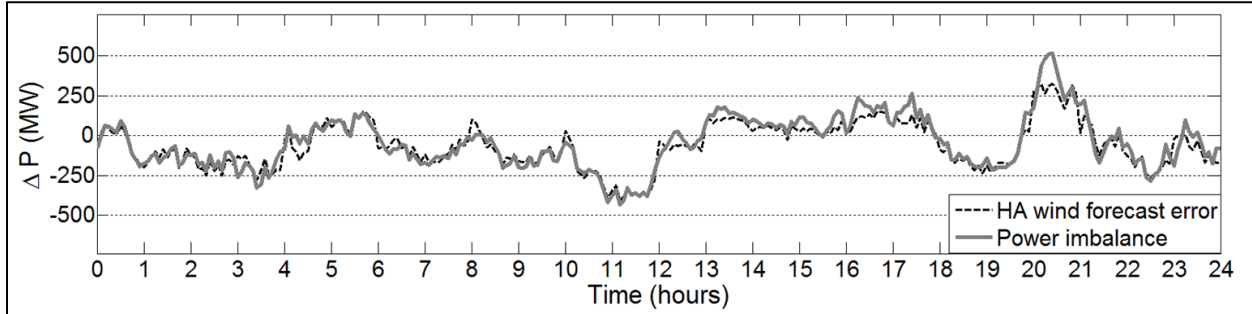

Figure 2: Power imbalance and wind forecast error

The power imbalance within the operating hour is due to the hour-ahead wind power forecast error, as Figure 2 compares the two power imbalances. The power imbalance will deviate the system frequency from its nominal level and the interchange power from hour-ahead schedule. The power imbalance is minimized in real time by adjusting the production from CHP and WPP in real time.

4.2 Real time balance operation

Active power reserves are always needed to keep the power system in balance and their amount depends also on the wind power penetration level and wind power forecast. The reserves are typically needed from fast conventional generating units to increase the system reliability and to ensure the power supply security. According to European Network of Transmission System Operators for Electricity (ENTSO-E), the type of reserves needed to keep the power system in balance can be classified as FCR, FRR and RR. In this study, the FCR is activated from all generating units; FRR is automatically activated from CHP and WPP through an AGC and RR only from CHP.

The generating units of the developed power system model responds to the power imbalance shown in Figure 2, by activating the FCR within 30 seconds for constant containment of frequency deviations and to constantly maintain the power balance in the whole synchronously interconnected system. The AGC responds afterwards and activates the FRR within 5 – 10 minutes, in order to maintain the active power balance in the power system and the power exchange with neighbouring power system at its schedule. The activation of FRR will also replace the FCR. Figure 3 shows and compare the power imbalance in the power system after the activation of FRR and the hour-ahead power imbalance.

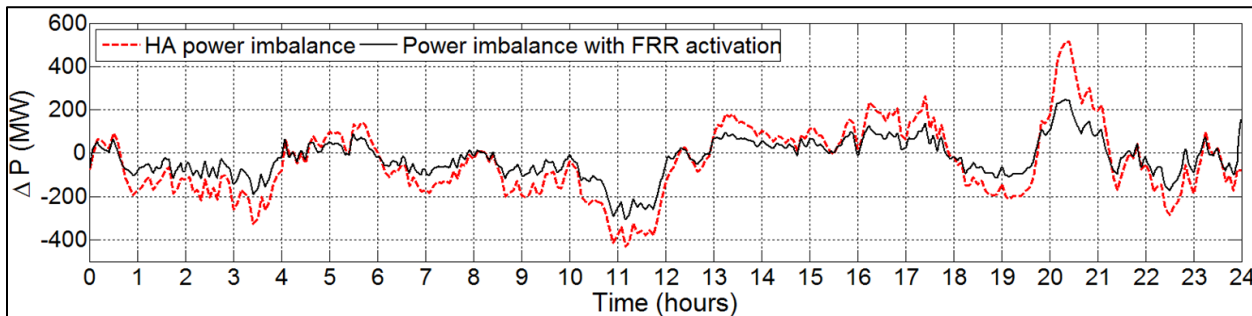

Figure 3: Power imbalance after FRR

The AGC activates the FCR with a coordinated control strategy between the CHP and the WPP. The CHP participate in up or down active power regulation, whereas the AGC down regulates the active power production from WPP only in case of generation excess and when CHP operate at their minimum limits or CHP dispatch reaches its lower limit. The AGC strategy integrates the WPP efficiently in secondary control by down regulating their production only in case of generation excess and utilizes the available wind power in case of generation deficiency.

The remaining power imbalance after the AGC response is minimized by the programmed activation of RR. These reserves are activated from CHP by an algorithm, designed to simulate the actions similar to the control room to tackle the real time power imbalances. The developed algorithm activates the regulating bids to reduce the real time power imbalances in the power system and make power system operation more reliable. The power imbalance after the activation of RR is compared in Figure 4 with the hour-ahead power imbalance and the power imbalance after AGC response. It can be seen that the imbalance has substantially reduced in a power system, where more than 50% of the total electricity is generated by wind power.

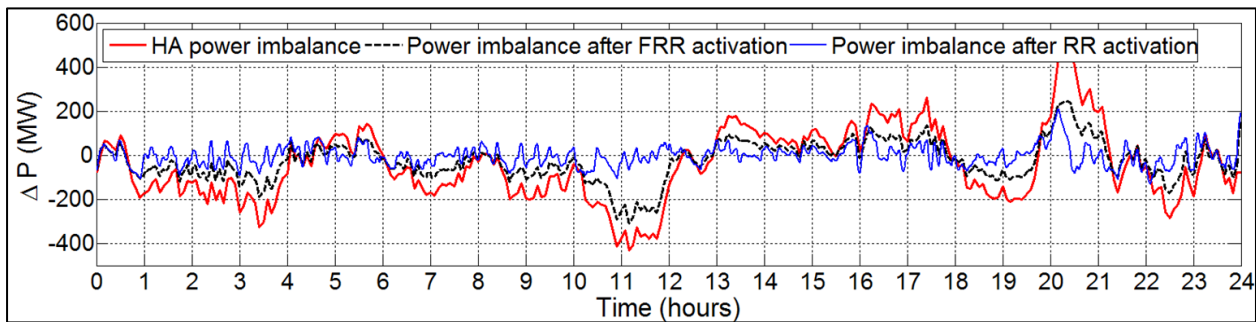

Figure 4: Final Power Imbalance

5 Conclusion

The integration of large amounts of wind power into the power system results in an extraordinary challenges e.g. power system balance control. The regulating reserves and its effective control are always needed to maintain active power in close balance. This paper proposes a platform for active power balance control, where hour-ahead dispatch plan with reduced planning horizon minimizes the real time regulation burden and the AGC with programmed control of regulating reserves makes the power system operation more reliable. The study performed and presented in this paper shows how power imbalances between load and generation, caused by wind power forecast error, can be compensated effectively by regulating the power from CHP and WPP in real time. The algorithm activates the regulating power from CHP while the AGC provides the required secondary response from CHP and WPP. However, better forecasting of wind speed and the load demand is still desirable for operational security of highly wind power integrated power system.

Acknowledgement

This paper is a part of PhD project funded by Sino-Danish center for education and research (SDC).

References

- [1] Global Wind Energy Council, "Global Wind Statics 2013", February 2014 [online], http://www.gwec.net/wp-content/uploads/2014/02/GWEC-PRstats-2013_EN.pdf
- [2] Vittrup C, "2013 was a record-setting year for Danish wind power" Energinet.dk, 15 January 2014 [online] <http://energinet.dk/EN/EI/Nyheder/Sider/2013-var-et-rekordaar-for-dansk-vindkraft.aspx>
- [3] Suwannarat A (2007), "Integration and Control of Wind Farms in the Danish Electricity System," Institute of Energy Technology Aalborg University, Aalborg

[4] Energinet.dk, “Wind Power to combat Climate Change”, [online] <http://energinet.dk/SiteCollectionDocuments/Engelske%20dokumenter/Klimaogmiljo/Wind%20power%20magazine.pdf>

[5] Sørensen P, Norheim I, Meibom P and Uhlen K (2007), “Simulations of wind power integration with complementary power system planning tools,” Electric Power Systems Research, p. 1069–1079

P 6: Basit A.; Hansen A. D.; Sørensen P.: “Dynamic model of frequency control in Danish power system with large scale integration of wind power”, China Wind Power (CWP), Beijing, 2013

Dynamic model of frequency control in Danish power system with large scale integration of wind power

A. Basit^{1,2,3}, A.D. Hansen¹, P. Sørensen¹

¹ Technical University of Denmark, Department of Wind Energy, Wind Energy Systems, DTU Risø Campus, Frederiksborgvej 399, Building 125, 4000 Roskilde, Denmark

² Sino-Danish Center for Education and Research, Niels Jensens Vej 2, 8000 Aarhus, Denmark

³ Corresponding author. Tel.: +45 2492 1623; Fax: +45 4677 5083; E-mail address: abdl@dtu.dk (A. Basit)

Abstract – This work evaluates the impact of large scale integration of wind power in future power systems when 50% of load demand can be met from wind power. The focus is on active power balance control, where the main source of power imbalance is an inaccurate wind speed forecast. In this study, a Danish power system model with large scale of wind power is developed and a case study for an inaccurate wind power forecast is investigated. The goal of this work is to develop an adequate power system model that depicts relevant dynamic features of the power plants and compensates for load generation imbalances, caused by inaccurate wind speed forecast, by an appropriate control of the active power production from power plants.

i. Introduction

Large scale future integration of wind power jeopardizes the reliability of the Danish power system operation. In this context, wind speed forecast plays an important role. For example an incorrect wind speed forecast implies that the generation and the power exchange plan with neighboring power systems deviate from their schedule. This issue can lead to power system balancing and control problems and can introduce several challenges in maintaining a reliable power system operation.

In spite of these challenges, the interest in the integration of large future wind power into power systems has motivated and accelerated new opportunities in modeling and control research of power systems. Adequate power system models and control strategies for long term dynamic simulations are for example desirable in the study of the active power balance control during imbalances in the power system, which is in focus in this present work. To manage the imbalances due to wind speed forecasting errors, Automatic Generation Control (AGC) strategies need for example to be revised to ensure safe, reliable and economical operation of the power system [1]. Moreover, an appropriate amount of reserves is required from fast conventional generating units to cope with the imbalances caused by uncertain wind nature.

This paper focuses therefore on developing a dynamic power system model which includes models for the Automatic Generation Control (AGC) system, centralized and de-centralized Heat and power (CHP and DCHP) units, full scale converter variable speed wind turbines (Type IV) and the interconnections with neighboring power system.

As described in [1] & [2], the eastern and western Danish power systems are synchronously connected to NORDEL and UCTE systems, respectively. An HVDC transmission line, namely the Great Belt link, connects the eastern and western Danish power systems. An overview of the active power balance control flow in the Danish power system model with the AGC contributions from conventional generating units, depicting, is shown in Figure 1.

The objective of this study is to illustrate how load generation imbalances caused by inaccurate wind speed forecast can be compensated by regulating the active

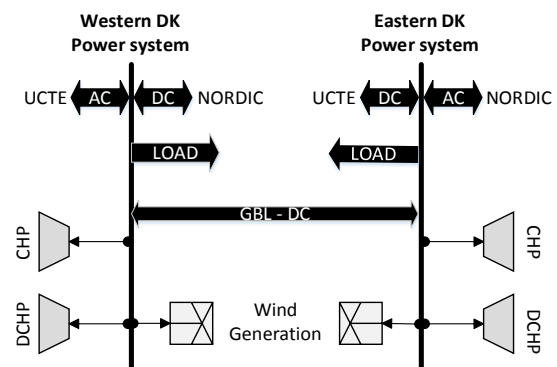

Figure 1: Danish power system model overview

power production from conventional power plants. The present power system model is developed to be able to reflect the dynamics of a power system with high wind power integration, as it is the case of the Danish power system in the future.

The paper is structured as follows. A brief description of the impact of the fluctuation nature of the wind on the power system operation is provided in Section II. The implemented power system model is then described in Section III, while simulation results are shown and analyzed in Section IV. Finally, Section V draws the partial conclusions and provides an outlook of the future work.

ii. Impacts on Power system operation

Wind speed is always fluctuating and so is the power generated from wind turbines. In interconnected power systems with large integration of wind power, one of the main challenges for the transmission system operator (TSO) is to maintain the active power balance in the power system in spite of wind power fluctuations. The active power reserves are needed to keep the system in balance and it depends on the level of wind power integration in power system and on weather conditions. For example, extreme weather conditions may result in loss of large amount of wind power within few minutes, jeopardizing the reliability and the security of the power system operation. Therefore spinning and secondary reserves [2] are needed from fast conventional units to increase the system reliability and makes its operation more secure. In this study the reserves from CHPs and DCHPs are used to maintain the power balance in power system and power exchange with neighboring power system at its scheduled level.

iii. Power system model

A power system model, suitable for long term dynamic simulation studies, has been developed in this work to study the active power control. It includes models for centralized and de-centralized Heat and power (CHP and DCHP) units, full scale converter variable speed wind turbines (Type IV), an Automatic Generation Control (AGC) system and for the interconnections with neighboring power system.

The models for the power units (CHPs and DCHPs) are developed in order to be able to depict different relevant dynamic features of the power plants.

An aggregated CHP model is for example developed based on the studies described in [1] to [4]. The CHP model, shown in Figure 2, consists of a speed governor, a boiler and a steam turbine. The model replicates the dynamic characteristics of the thermal boiler that can affect the real power system operation.

An aggregated DCHP model is developed in this work based on studies described in [1], [2] & [5]. Figure 3 shows the implemented DCHP model with a speed governor and a simple cycle gas turbine. It reflects the faster response of all other conventional units than CHP in the Danish power system.

An aggregated wind farm model of a Type IV wind turbine is implemented based on the description provided in [6] & [7]. The wind turbine model, shown in Figure 4, can function both for normal operation or curtailed operation. It consists of a pitch controller, an aerodynamic model, a 2-mass mechanical model and a maximum power point tracking table (MPPT) as well

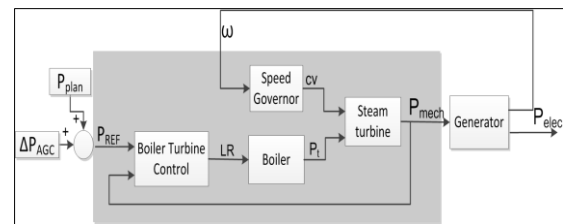

Figure 2: Aggregated CHP model – source [1] - [4]

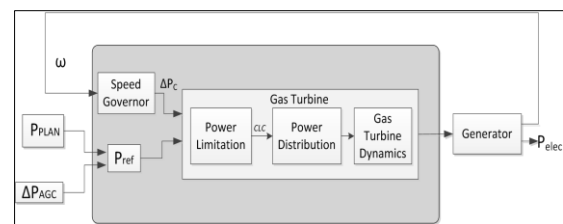

Figure 3: Aggregated DCHP model – source [1], [2] & [5]

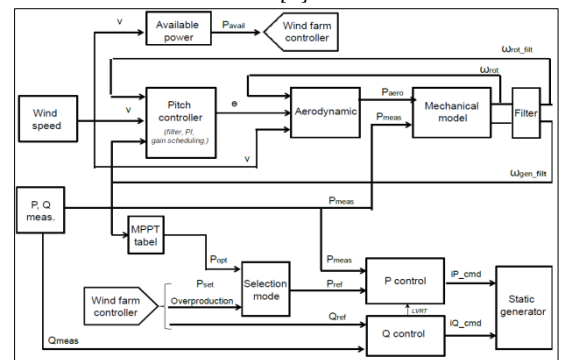

Figure 4: Aggregated Type IV wind turbine – source [6] & [7]

as an active and reactive power controller.

The power system model is developed taking into account the ramping capabilities of the generating units and the exchange power with neighboring power systems. It is worth mentioning that Denmark's neighboring power systems do not have same ramp rates for power exchange. For example, in the Nordel power system, the agreed exchange power shall be ramped within 30 minutes and shall begin 15 minutes before the agreed exchange hour. In the UCTE power system, the exchange power shall be ramped within 10 minutes and starts 5 minutes before the agreed exchange hour.

As well known, any imbalance in the active power will result in frequency deviation from its nominal level.

The speed governors of the power plants in operation sense the frequency change and releases primary reserves to stabilize the system frequency. The frequency is fully restored to its nominal level by secondary control, which is activated either manually by changing the generator power set point or automatically through an AGC. In Denmark, the secondary reserves are activated manually, apart from a load frequency controller (± 90 MW) in western Denmark with Germany border to respond to any deviations from scheduled plan. Therefore it is relevant to study AGC in this project. The implemented AGC in this work is shown in figure 5. Notice that it changes the generators active power set point depending on power imbalance in power system i.e. area control error (ACE) and their participation factors.

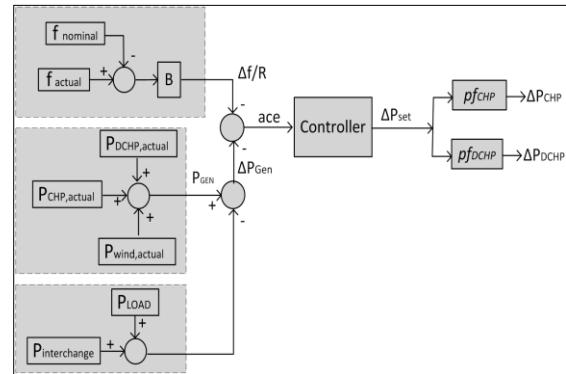

Figure 5: AGC model

iv. Simulation studies

In this section, different studies are carried out in order to illustrate the dynamic features of the implemented power system model with respect to the active power balance control. A set of simulations are performed using time series for generation, load and power exchange corresponding to one particular winter day with high wind speed. These time series are the assumptions from the Danish TSO for future power system where wind generating units have almost the same capacity as conventional generating units. On this particular day, the power generated from wind turbines and conventional units as well as the load demand in eastern and western Danish power system are shown in Figure 6 & 7, respectively. The availability of wind on this particular day allows the wind turbines to generate more power than conventional generating units.

According to [2], in Denmark, the electricity markets are balanced on hourly basis taking into account the hour ahead forecasted value of wind and load. Based on these forecasts, the generating unit's set points are decided for balancing the power system. If the actual wind power generated within the operating hour is not the same as the forecasted one, it will result in a power mismatch between generation and load. Figure 8 show the wind power deviation from its hour ahead predicted value in eastern and western Danish power system. The

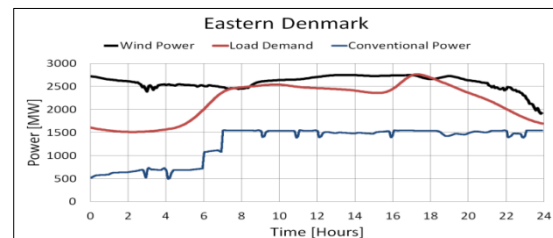

Figure 6: East Dk - Generation

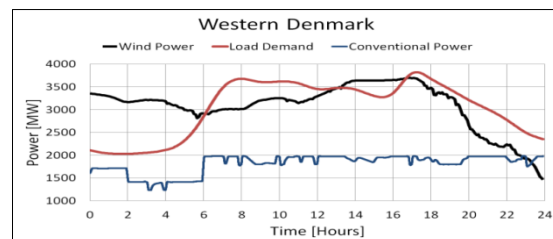

Figure 7: West Dk - Generation

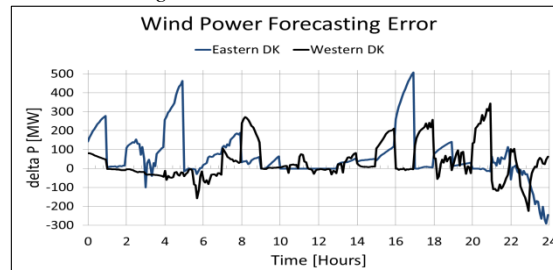

Figure 8: Wind Power forecast error

deviation in wind power is as follows:

$$P_{error}^{wind} = P_{actual}^{wind} - P_{hour\ ahead}^{wind} \quad (1)$$

The wind forecasting error creates an imbalance between generation and load, which yields to a change in the system frequency. The process is as following, the speed governors provide the initial support by releasing the primary reserves automatically. Afterwards the AGC provides new set point to the generators based on their participation factors and the ACE. The support from conventional generating units to reduce the imbalance power can be seen in Figure 6 & 7 as spikes at start of each hour and the ramp within an hour.

Figure 9 & 10 shows the power imbalance in eastern and western Denmark power system respectively, while Figure 11 & 12 shows the corresponding system frequencies in these power systems. The power imbalance in these power systems do not return to zero although the AGC changes the generators set points. The reason is that the AGC output is limited to ± 90 MW, which restricts the secondary action from providing the power equal to wind power forecast error. The huge spikes in these figures are due to the different power exchange ramp rates with neighboring power systems, as mentioned before, namely the Nordel and UCTE power systems have different ramp rates and power exchange starts at different times. This means that if the power has to be transported from one power system to another, it will end in power surplus or deficit in the Danish power system at the commencement of each hour and will result in power imbalance.

The illustrated deviation in the system frequency corresponds to the amount of power imbalance. The surplus power results in frequency rise while the deficit in frequency drop. Notice that, in spite of huge power imbalance as illustrated in the future Danish power system, the system frequency remains within the normal range i.e. 49.9 – 50.1 Hz. This is because that the Danish power system is synchronously connected to stiff and large electrical network of UCTE and Nordel. They offer enormous frequency bias, which avoids frequency abnormality in Danish power system even with large scale integration of wind power.

v. Conclusion

This paper studies the impact of large scale integration of wind power on power system operation. An adequate Danish power system model is developed to analyze the system behavior during power imbalance, where key reason for an imbalance is an inaccurate wind speed forecast. The model examines the reliability and the security of power system pertaining to power deviation from its schedule. Thus the availability of reserves, specified control strategy and interconnection with strong electrical networks decides the level of integration of wind power in any power system.

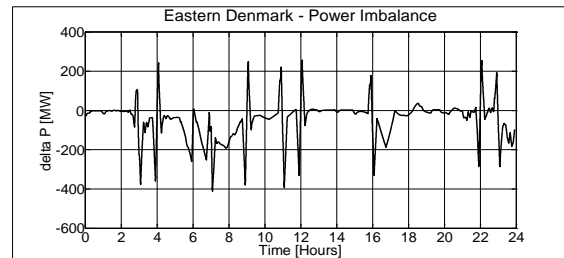

Figure 9: Imbalance power in East DK

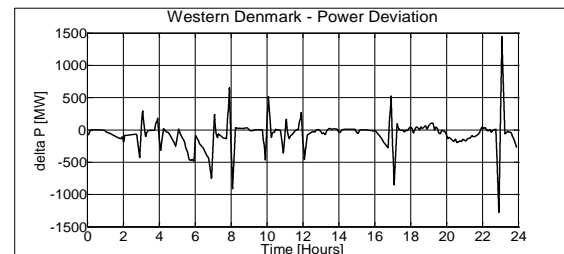

Figure 10: Imbalance power in West DK

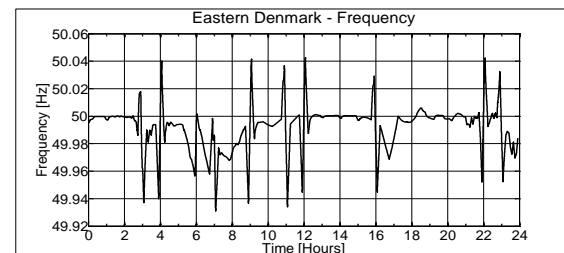

Figure 11: System frequency East DK

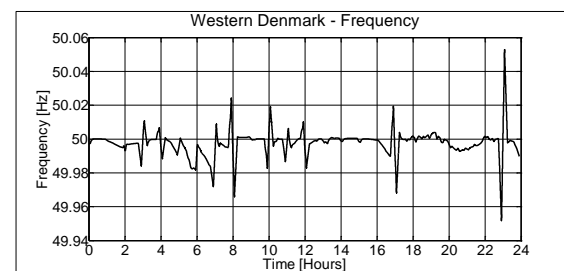

Figure 12: System frequency West DK

vi. Acknowledgement

The author would like to thank Sino-Danish center for education and research (SDC) for funding this PhD project

vii. References

- [1]: A. Suwannarat, "Integration and Control of Wind Farms in the Danish Electricity System", Phd thesis, Institute of Energy Technology, Aalborg University, 2007.
- [2]: Georgios Giannopoulos, 'Frequency control in area with large scale wind power', Master thesis, July 2012
- [3] F. De Mello, "Dynamic models for fossil fueled steam units in power system studies," IEEE Transaction on Power Systems, vol. 6, pp. 753-761, 1991.
- [4] R. Byerly, "Dynamic models for steam and hydro turbines in power system studies," IEEE Transactions on Power Apparatus and Systems, pp. 1904-1915, 1973
- [5] "CIGRE Task Force 25 of Advisory Group 02 of Study Committee C4 (Task ForceC4.02.25), "Modeling of Gas Turbines and Steam Turbines in Combined CyclePower Plants", 2003.
- [6] Hansen A.D., Margaris I. Germán C. Tarnowski, Florin Iov, 'Simplified Type 4 wind turbine modeling for future ancillary services', EWEC 2013
- [7]: Hansen A. D., Margaris I., "Type IV Wind Turbine Model", DTU wind energy, 2013

P7: Basit A.; Hansen A.D.; Margaris I.D.; Hansen J.C., "A Review of Grid Requirements for Wind Farm in Denmark and China", China Wind Power (CWP), Beijing, 2012

Dynamic model of frequency control in Danish power system with large scale integration of wind power

A. Basit^{1,2,3}, A.D. Hansen¹, P. Sørensen¹

¹ Technical University of Denmark, Department of Wind Energy, Wind Energy Systems, DTU Risø Campus, Frederiksborgvej 399, Building 125, 4000 Roskilde, Denmark

² Sino-Danish Center for Education and Research, Niels Jensens Vej 2, 8000 Aarhus, Denmark

³ Corresponding author. Tel.: +45 2492 1623; Fax: +45 4677 5083; E-mail address: abdl@dtu.dk (A. Basit)

Abstract – This work evaluates the impact of large scale integration of wind power in future power systems when 50% of load demand can be met from wind power. The focus is on active power balance control, where the main source of power imbalance is an inaccurate wind speed forecast. In this study, a Danish power system model with large scale of wind power is developed and a case study for an inaccurate wind power forecast is investigated. The goal of this work is to develop an adequate power system model that depicts relevant dynamic features of the power plants and compensates for load generation imbalances, caused by inaccurate wind speed forecast, by an appropriate control of the active power production from power plants.

i. Introduction

Large scale future integration of wind power jeopardizes the reliability of the Danish power system operation. In this context, wind speed forecast plays an important role. For example an incorrect wind speed forecast implies that the generation and the power exchange plan with neighboring power systems deviate from their schedule. This issue can lead to power system balancing and control problems and can introduce several challenges in maintaining a reliable power system operation.

In spite of these challenges, the interest in the integration of large future wind power into power systems has motivated and accelerated new opportunities in modeling and control research of power systems. Adequate power system models and control strategies for long term dynamic simulations are for example desirable in the study of the active power balance control during imbalances in the power system, which is in focus in this present work. To manage the imbalances due to wind speed forecasting errors, Automatic Generation Control (AGC) strategies need for example to be revised to ensure safe, reliable and economical operation of the power system [1]. Moreover, an appropriate amount of reserves is required from fast conventional generating units to cope with the imbalances caused by uncertain wind nature.

This paper focuses therefore on developing a dynamic power system model which includes models for the Automatic Generation Control (AGC) system, centralized and de-centralized Heat and power (CHP and DCHP) units, full scale converter variable speed wind turbines (Type IV) and the interconnections with neighboring power system.

As described in [1] & [2], the eastern and western Danish power systems are synchronously connected to NORDEL and UCTE systems, respectively. An HVDC transmission line, namely the Great Belt link, connects the eastern and western Danish power systems. An overview of the active power balance control flow in the Danish power system model with the AGC contributions from conventional generating units, depicting, is shown in Figure 1.

The objective of this study is to illustrate how load generation imbalances caused by inaccurate wind speed forecast can be compensated by regulating the active

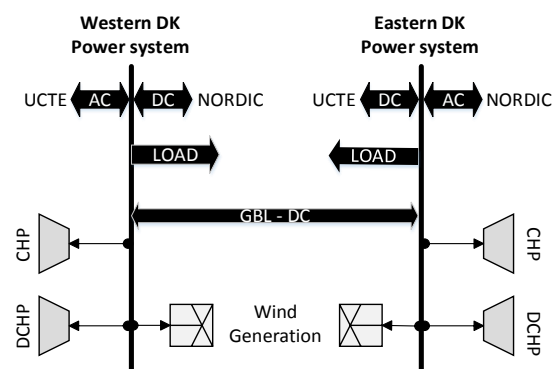

Figure 1: Danish power system model overview

power production from conventional power plants. The present power system model is developed to be able to reflect the dynamics of a power system with high wind power integration, as it is the case of the Danish power system in the future.

The paper is structured as follows. A brief description of the impact of the fluctuation nature of the wind on the power system operation is provided in Section II. The implemented power system model is then described in Section III, while simulation results are shown and analyzed in Section IV. Finally, Section V draws the partial conclusions and provides an outlook of the future work.

ii. Impacts on Power system operation

Wind speed is always fluctuating and so is the power generated from wind turbines. In interconnected power systems with large integration of wind power, one of the main challenges for the transmission system operator (TSO) is to maintain the active power balance in the power system in spite of wind power fluctuations. The active power reserves are needed to keep the system in balance and it depends on the level of wind power integration in power system and on weather conditions. For example, extreme weather conditions may result in loss of large amount of wind power within few minutes, jeopardizing the reliability and the security of the power system operation. Therefore spinning and secondary reserves [2] are needed from fast conventional units to increase the system reliability and makes its operation more secure. In this study the reserves from CHPs and DCHPs are used to maintain the power balance in power system and power exchange with neighboring power system at its scheduled level.

iii. Power system model

A power system model, suitable for long term dynamic simulation studies, has been developed in this work to study the active power control. It includes models for centralized and de-centralized Heat and power (CHP and DCHP) units, full scale converter variable speed wind turbines (Type IV), an Automatic Generation Control (AGC) system and for the interconnections with neighboring power system.

The models for the power units (CHPs and DCHPs) are developed in order to be able to depict different relevant dynamic features of the power plants.

An aggregated CHP model is for example developed based on the studies described in [1] to [4]. The CHP model, shown in Figure 2, consists of a speed governor, a boiler and a steam turbine. The model replicates the dynamic characteristics of the thermal boiler that can affect the real power system operation.

An aggregated DCHP model is developed in this work based on studies described in [1], [2] & [5]. Figure 3 shows the implemented DCHP model with a speed governor and a simple cycle gas turbine. It reflects the faster response of all other conventional units than CHP in the Danish power system.

An aggregated wind farm model of a Type IV wind turbine is implemented based on the description provided in [6] & [7]. The wind turbine model, shown in Figure 4, can function both for normal operation or curtailed operation. It consists of a pitch controller, an aerodynamic model, a 2-mass mechanical model and a maximum power point tracking table (MPPT) as well

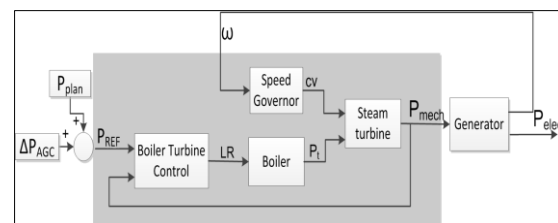

Figure 2: Aggregated CHP model – source [1] - [4]

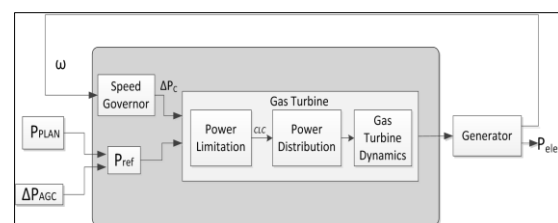

Figure 3: Aggregated DCHP model – source [1], [2] & [5]

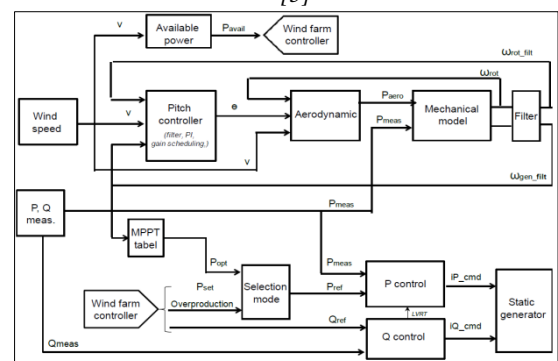

Figure 4: Aggregated Type IV wind turbine – source [6] & [7]

as an active and reactive power controller.

The power system model is developed taking into account the ramping capabilities of the generating units and the exchange power with neighboring power systems. It is worth mentioning that Denmark's neighboring power systems do not have same ramp rates for power exchange. For example, in the Nordel power system, the agreed exchange power shall be ramped within 30 minutes and shall begin 15 minutes before the agreed exchange hour. In the UCTE power system, the exchange power shall be ramped within 10 minutes and starts 5 minutes before the agreed exchange hour.

As well known, any imbalance in the active power will result in frequency deviation from its nominal level.

The speed governors of the power plants in operation sense the frequency change and releases primary reserves to stabilize the system frequency. The frequency is fully restored to its nominal level by secondary control, which is activated either manually by changing the generator power set point or automatically through an AGC. In Denmark, the secondary reserves are activated manually, apart from a load frequency controller (± 90 MW) in western Denmark with Germany border to respond to any deviations from scheduled plan. Therefore it is relevant to study AGC in this project. The implemented AGC in this work is shown in figure 5. Notice that it changes the generators active power set point depending on power imbalance in power system i.e. area control error (ACE) and their participation factors.

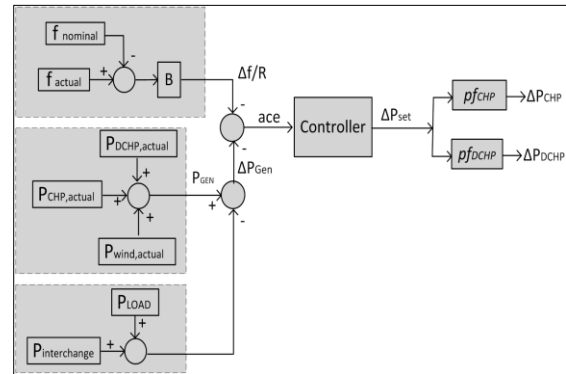

Figure 5: AGC model

iv. Simulation studies

In this section, different studies are carried out in order to illustrate the dynamic features of the implemented power system model with respect to the active power balance control. A set of simulations are performed using time series for generation, load and power exchange corresponding to one particular winter day with high wind speed. These time series are the assumptions from the Danish TSO for future power system where wind generating units have almost the same capacity as conventional generating units. On this particular day, the power generated from wind turbines and conventional units as well as the load demand in eastern and western Danish power system are shown in Figure 6 & 7, respectively. The availability of wind on this particular day allows the wind turbines to generate more power than conventional generating units.

According to [2], in Denmark, the electricity markets are balanced on hourly basis taking into account the hour ahead forecasted value of wind and load. Based on these forecasts, the generating unit's set points are decided for balancing the power system. If the actual wind power generated within the operating hour is not the same as the forecasted one, it will result in a power mismatch between generation and load. Figure 8 show the wind power deviation from its hour ahead predicted value in eastern and western Danish power system. The

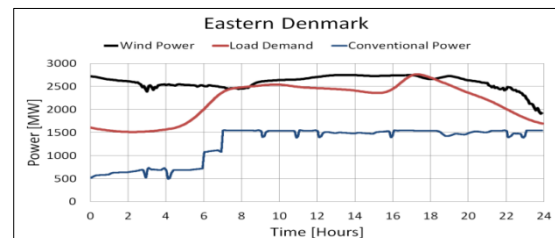

Figure 6: East Dk - Generation

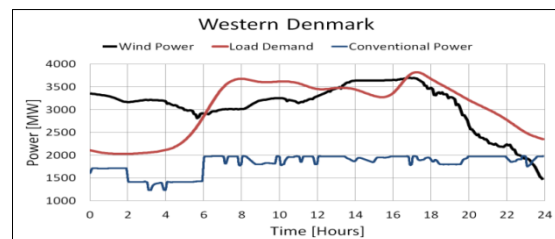

Figure 7: West Dk - Generation

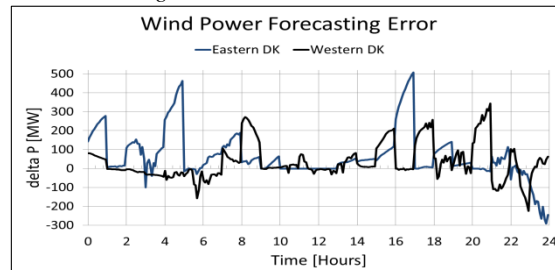

Figure 8: Wind Power forecast error

deviation in wind power is as follows:

$$P_{error}^{wind} = P_{actual}^{wind} - P_{hour\ ahead}^{wind} \quad (1)$$

The wind forecasting error creates an imbalance between generation and load, which yields to a change in the system frequency. The process is as following, the speed governors provide the initial support by releasing the primary reserves automatically. Afterwards the AGC provides new set point to the generators based on their participation factors and the ACE. The support from conventional generating units to reduce the imbalance power can be seen in Figure 6 & 7 as spikes at start of each hour and the ramp within an hour.

Figure 9 & 10 shows the power imbalance in eastern and western Denmark power system respectively, while Figure 11 & 12 shows the corresponding system frequencies in these power systems. The power imbalance in these power systems do not return to zero although the AGC changes the generators set points. The reason is that the AGC output is limited to ± 90 MW, which restricts the secondary action from providing the power equal to wind power forecast error. The huge spikes in these figures are due to the different power exchange ramp rates with neighboring power systems, as mentioned before, namely the Nordel and UCTE power systems have different ramp rates and power exchange starts at different times. This means that if the power has to be transported from one power system to another, it will end in power surplus or deficit in the Danish power system at the commencement of each hour and will result in power imbalance.

The illustrated deviation in the system frequency corresponds to the amount of power imbalance. The surplus power results in frequency rise while the deficit in frequency drop. Notice that, in spite of huge power imbalance as illustrated in the future Danish power system, the system frequency remains within the normal range i.e. 49.9 – 50.1 Hz. This is because that the Danish power system is synchronously connected to stiff and large electrical network of UCTE and Nordel. They offer enormous frequency bias, which avoids frequency abnormality in Danish power system even with large scale integration of wind power.

v. Conclusion

This paper studies the impact of large scale integration of wind power on power system operation. An adequate Danish power system model is developed to analyze the system behavior during power imbalance, where key reason for an imbalance is an inaccurate wind speed forecast. The model examines the reliability and the security of power system pertaining to power deviation from its schedule. Thus the availability of reserves, specified control strategy and interconnection with strong electrical networks decides the level of integration of wind power in any power system.

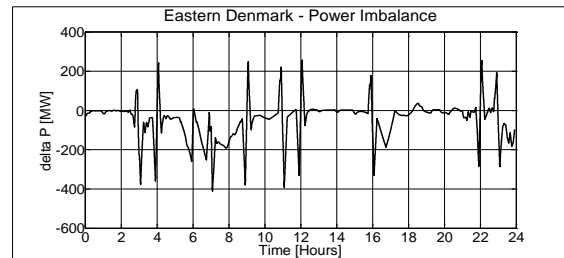

Figure 9: Imbalance power in East DK

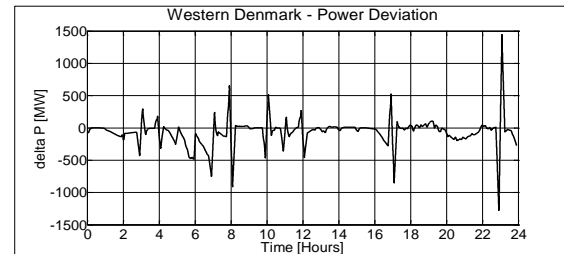

Figure 10: Imbalance power in West DK

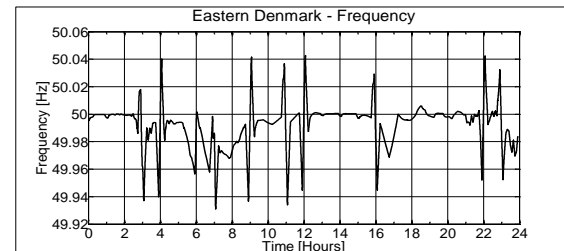

Figure 11: System frequency East DK

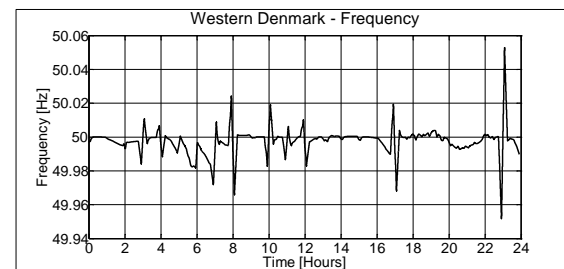

Figure 12: System frequency West DK

vi. Acknowledgement

The author would like to thank Sino-Danish center for education and research (SDC) for funding this PhD project

vii. References

- [1]: A. Suwannarat, "Integration and Control of Wind Farms in the Danish Electricity System", Phd thesis, Institute of Energy Technology, Aalborg University, 2007.
- [2]: Georgios Giannopoulos, 'Frequency control in area with large scale wind power', Master thesis, July 2012
- [3] F. De Mello, "Dynamic models for fossil fueled steam units in power system studies," IEEE Transaction on Power Systems, vol. 6, pp. 753-761, 1991.
- [4] R. Byerly, "Dynamic models for steam and hydro turbines in power system studies," IEEE Transactions on Power Apparatus and Systems, pp. 1904-1915, 1973
- [5] "CIGRE Task Force 25 of Advisory Group 02 of Study Committee C4 (Task ForceC4.02.25), "Modeling of Gas Turbines and Steam Turbines in Combined CyclePower Plants", 2003.
- [6] Hansen A.D., Margaris I. Germán C. Tarnowski, Florin Iov, 'Simplified Type 4 wind turbine modeling for future ancillary services', EWEC 2013
- [7]: Hansen A. D., Margaris I., "Type IV Wind Turbine Model", DTU wind energy, 2013

DTU Wind Energy is a department of the Technical University of Denmark with a unique integration of research, education, innovation and public/private sector consulting in the field of wind energy. Our activities develop new opportunities and technology for the global and Danish exploitation of wind energy. Research focuses on key technical-scientific fields, which are central for the development, innovation and use of wind energy and provides the basis for advanced education at the education.

We have more than 230 staff members of which approximately 60 are PhD students. Research is conducted within 9 research programmes organized into three main topics: Wind energy systems, Wind turbine technology and Basics for wind energy.

Technical University of Denmark

Department of Wind Energy

Frederiksborgvej 399

Building 118

4000 Roskilde

Denmark

Phone 46 77 50 85

info@vindenergi.dtu.dk

www.vindenergi.dtu.dk

Wind power integration into the automatic generation control of power systems with large-scale wind power

Abdul Basit^{1,2}, Anca Daniela Hansen¹, Mufit Altin¹, Poul Sørensen¹, Mette Gamst³

¹Department of Wind Energy, Technical University of Denmark, Frederiksborgvej 399, Building 125, 4000 Roskilde, Denmark

²Sino-Danish Centre for Education and Research, Niels.JensensVej 2, 8000 Aarhus, Denmark

³Energinet.dk, Tonnekjærvej 65, 7000 Fredericia, Denmark

E-mail: abdl@dtu.dk

Published in *The Journal of Engineering*; Received on 13th August 2014; Accepted on 20th August 2014

Abstract: Transmission system operators have an increased interest in the active participation of wind power plants (WPP) in the power balance control of power systems with large wind power penetration. The emphasis in this study is on the integration of WPPs into the automatic generation control (AGC) of the power system. The present paper proposes a coordinated control strategy for the AGC between combined heat and power plants (CHPs) and WPPs to enhance the security and the reliability of a power system operation in the case of a large wind power penetration. The proposed strategy, described and exemplified for the future Danish power system, takes the hour-ahead regulating power plan for generation and power exchange with neighbouring power systems into account. The performance of the proposed strategy for coordinated secondary control is assessed and discussed by means of simulations for different possible future scenarios, when wind power production in the power system is high and conventional production from CHPs is at a minimum level. The investigation results of the proposed control strategy have shown that the WPPs can actively help the AGC, and reduce the real-time power imbalance in the power system, by down regulating their production when CHPs are unable to provide the required response.

1 Introduction

The active power balance control is becoming more significant for transmission system operators (TSOs) over the years because of the dramatic increase of wind power penetration into the power systems. Nowadays, power systems are evolving from classical systems operated and controlled by the conventional power plants into power systems based on wind power to a larger extent. This means, that TSOs must be able to cope with new challenges in power system operation, raising concerns about dynamic security and reliability. In an interconnected power system, the TSO should maintain the system frequency of each area within specified limits and the tie line power flow at its plan. Traditionally, conventional power plants have the task of maintaining the active power balance and are capable of meeting the TSO guidelines. Their possible future replacement by wind power plants (WPPs) of similar size increases the risk of system failures, unless the TSOs revise and set new requirements for WPPs, that is, to participate in active power balance control.

Active power control from WPPs is a challenging technical issue, which has initiated an intensification of this research area in academia and industry. Several studies regarding active power control from WPPs have been performed in the past few years. For example, a comprehensive state-of-the-art review, regarding the frequency regulation and spinning reserves from variable speed wind turbines, is conducted in [1, 2]. Results from [3] show that increasing wind power integration alters the frequency behaviour and therefore TSOs must develop solutions to meet the challenges. A Dutch case study has been developed in [4] to assess the automatic generation control (AGC) performance in the presence of large-scale wind power and found that additional reserves are required for keeping the area control error (ACE) at the same level. Recent Chinese studies [5] have led to the conclusion that the fluctuation from WPPs can be controlled via conventional generators. In the USA, intensive work on the development of wind turbine control system to vary a turbine's active power output as demanded by the TSO has been conducted and described in detail in [6]. According to [7], the WPPs can participate in frequency regulation services with

energy storage devices such as super capacitor banks, while [8] analyses the benefits of active power regulation from WPPs. However, the increasing wind power integration may replace or dominate the electricity generation from conventional power plants in future power systems and it may require active participation from the WPPs in the active power balance control on the power system level. Further studies in this context, for example, WPPs integration into the AGC system, are necessary to enhance operational security of future power system with large-scale wind power integration.

The objective of this study is to investigate how WPPs can actively participate in the secondary frequency control. This study proposes a coordinated control strategy for the AGC between the combined heat and power plants (CHPs) and WPPs in order to improve the active power balance in the power system with minimum secondary dispatch cost. The described control strategy regulates the active power production from CHPs and WPPs, depending on operating reserves, dispatch limit and the generating cost. The WPPs can only provide down regulation services if they are not operating in delta mode, where wind power is kept as reserve. The proposed strategy is developed and exemplified considering the Danish power system, as this is characterised by the highest wind power penetration level in Europe and aims to further increase the wind power capacity to cover almost 50% of the total energy requirement by 2020 [9].

This study is structured as follows. A brief description of the developed dynamic power system model implemented in Power Factory is provided first. The active power balance control, taking into account the hour-ahead (HA) regulating power plan for generation and power exchange with neighbouring power systems and real-time balance control, is then described. The implementation of the proposed control strategy for the integration of wind power into the AGC of the power system follows next. The high wind penetration scenario for the Danish power system in year 2020 is used to assess the performance of the presented coordinated AGC strategy between CHP and WPP through a set of simulations with the developed power system model. Finally, conclusive remarks are given in the final section.

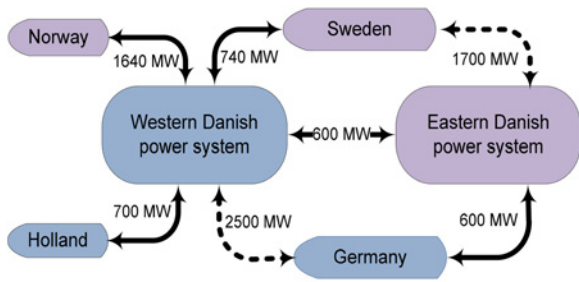

Fig. 1 Interconnection capacities for the year 2020 [10]

2 Dynamic power system modelling

As previously mentioned, the Danish power system is used to validate the performance of the proposed coordinated control strategy for AGC. The Danish power system is electrically separated into two synchronous areas, that is, eastern and western Danish power systems, and synchronised with the strong Nordic and Continental European (CE) synchronous power systems, respectively. Fig. 1 shows the interconnection capacities of the Danish power system with its neighbouring powers as planned for the year 2020 [10], where AC interconnections are presented as dotted line and the DC interconnections as solid line.

The electrical power generation in Denmark is a combination of conventional and renewable generation sources. The conventional power generation is typically from CHPs and de-centralised CHPs (DCHPs), whereas renewable generation is usually from WPPs. Studying the coordinated AGC strategy in the Danish power system requires a detailed representation of the power system that includes conventional power plants, WPPs and the interconnection with neighbouring power systems, as shown in Fig. 2. The aggregated models developed for this paper reduce the computation effort but still contain the dynamic features relevant for the present investigation, without missing relevant behaviours of the generating systems.

The developed power system model and the description of the HA planned and real-time inputs, provided by the power balancing model and the AGC, respectively, are based on the description in [11–15]. The power balancing model, called simulation power balancing model (SimBa), provides the HA regulating power plans for a balanced power system based on the input time series from day-ahead (DA) spot market and HA forecast of wind power.

2.1 Conventional power plants (CHPs and DCHPs)

Aggregated models for CHP and DCHP are developed based on the studies described in [12–14]. These models contain both the primary and secondary control capabilities and reflect the relevant dynamic features for long-term dynamic simulation studies. The response time associated with a CHP is in the order of minutes

and is the dominant characteristic for power system studies. In the proposed strategy, the reference power for CHP and DCHP is calculated based on the HA plan from power balancing model ($P_{\text{plan_CHP}}$ and $P_{\text{plan_DCHP}}$) and the power correction from the AGC (ΔP_{CHP}).

2.2 Wind power plants

At power system level, the aggregated performance of a large number of wind turbines is in focus rather than the detailed performance of individual wind turbines. An aggregated WPP model, based on the IEC61400-27-1 recommendations [15] and further simplified for the secondary active power control purpose of the present paper, has been implemented.

As illustrated in Fig. 3, the aggregated wind turbine model includes an active power controller and a generator system. The generator system simulates the wind turbine response. The wind turbine model provides the relevant dynamic response of WPP with respect to active power control capabilities, using as inputs the measured power at point of common coupling (PCC) and the reference power ($P_{\text{ref_WPP}}$) from the WPP active power controller. The $P_{\text{ref_WPP}}$ to the wind turbine model is calculated inside the WPP active power controller based on two input signals. One input signal is conducted based on the primary response from the WPP (ΔP_c), whereas the other (P_{ref}) is determined based on the required secondary response (ΔP_{WPP}) from the AGC and the available wind power signal ($P_{\text{WPP_avail}}$) from the power balancing model. Besides the two mentioned inputs signals, the WPP active power controller is also using information on the measured power at PCC ($P_{\text{meas_PCC}}$) in the decision of the $P_{\text{ref_WPP}}$.

3 Active power balance control

The TSOs are obliged to securely operate the power system in transporting the generated electricity to the end consumers and maintain the power balance in the power system. This electricity is traded in the electricity markets by the balance responsible companies, who can produce, consume or retail. The balance responsible companies trade for each operating period during the next day in the DA market. The dispatch bids are selected with foremost intent of preserving system integrity and to minimise the production cost. The balance responsible companies also trade on the intraday (HA) market before the actual operation period, taking into account the updated wind power forecasts or unavailability of power plants. The following sections explain first the power balancing model with the generation of HA regulating power plan in a time scale of 5 min for the power plants and power exchange with neighbouring power systems and then the real-time power balance control in the power system.

3.1 HA power balance control

The TSOs use and combine information from different programmes to ensure the power balance in the power system. These

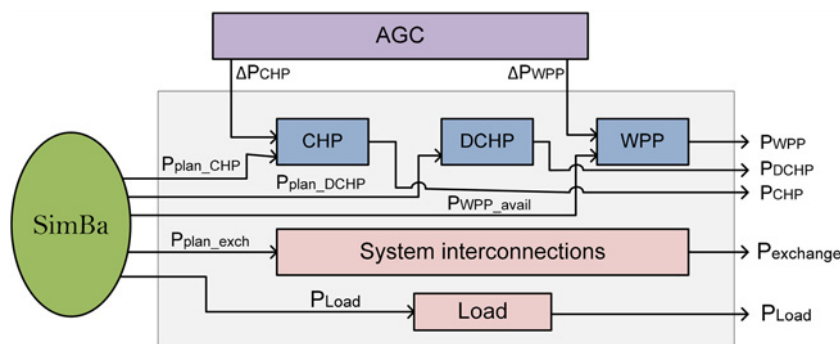

Fig. 2 Inputs–outputs overview of the dynamic power system model

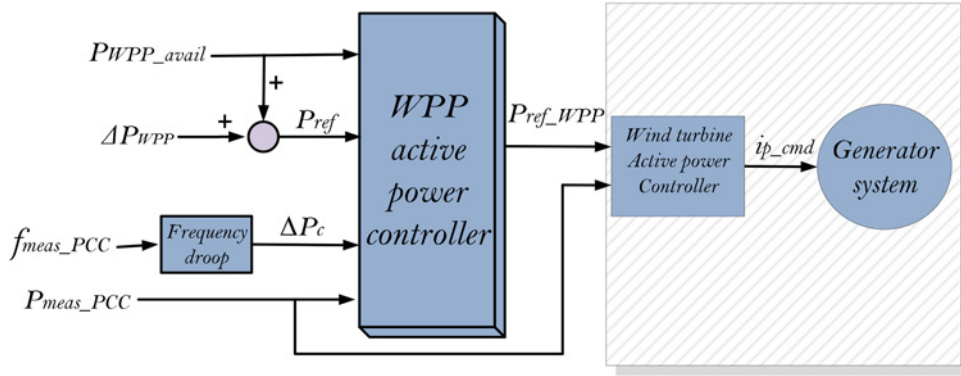

Fig. 3 Aggregated WPP model [15]

programmes provide information regarding wind power forecast and load demand, and also simulate the regulating power plan for balanced power system. SimBa, for instance, is the kind of programme used to simulate HA regulating power plan in Denmark. SimBa generates HA plans for the intra-hour balance with 5 min periods based on input time series from DA market model and HA forecast of wind power. The DA time series (P_{plan_DA}) are provided by wind power integration in liberalised electricity market (WILMAR), whereas the correlated wind power fluctuations (CorWind) model provides the HA forecast of wind power (P_{WPP_HA}), as shown in Fig. 4. The CorWind model also provides the DA forecast of wind power (P_{WPP_DA}) and the available wind power (P_{WPP_avail}).

SimBa models the power system taking into account the current grid regulations and the electricity market rules. SimBa uses inputs from WILMAR that include hourly values for energy production, load and the power exchange between interconnected areas and HA wind power forecasts from CorWind. Based on these inputs, SimBa balances the power system and provides HA 5 min period plan for generating plants and power exchange with neighbouring power systems, that is, P_{plan_HA} .

3.2 Real-time power balance control

The active power reserves are always needed to keep the power system in balance. In a highly wind power integrated power system, the reserves from fast conventional generating units increase the system reliability and also ensure the power supply security. According to European Network of Transmission System Operators for Electricity (ENTSO-E), the type of reserves needed to keep the power system in balance can be classified as

frequency containment reserves (FCRs), frequency restoration reserves (FRRs) and replacement reserves (RRs) [16]. FCR are activated automatically within 30 s to constantly control frequency deviations and maintain the power balance in the whole synchronously interconnected system. FRR maintains the active power balance in the power system, and the power exchange with neighbouring power system at its schedule, and are typically activated (manually or automatically) within 15 min. RR restores the FRR back to the required level and responds from several minutes up to hours. The total volume of FCR in CE and Nordic region is ± 3000 and ± 600 MW, respectively [16]. In this paper, power imbalance is controlled through FCR and automatic FRR. Conventional power plants and WPPs provide the FCR, whereas FRR is activated from CHPs and WPPs through AGC.

In Denmark, the active power balance is controlled through activation of regulating bids from the Nordic Operational Information System (NOIS) list in the TSO's control room and also through AGC, with a reserved capacity of ± 90 MW acting on the border of western Denmark with Germany. However, for the present investigation, it is assumed that the power imbalance is controlled only through AGC. As the focus in this study is on integrating WPPs into the generation control, an AGC for eastern and western Danish power systems is implemented together with WPPs to investigate the AGC action in the Danish power system as in 2020 with an active integrated role of WPPs in the AGC.

4 Coordinated AGC between CHP and WPP

A coordinated control methodology for AGC, where both CHP and WPP are participating actively, is presented in this paper. The following sections explain first the implementation of an AGC and

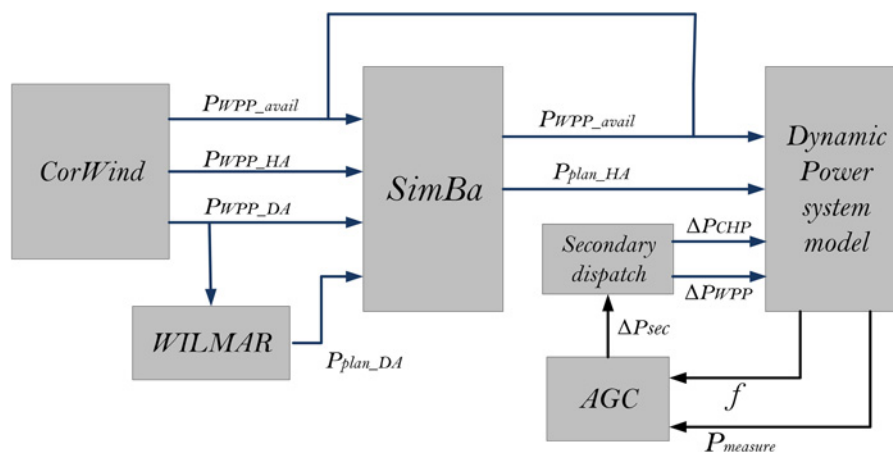

Fig. 4 Overview of the signals between CorWind, WILMAR, SimBa, the dynamic power system model and the AGC

then the coordinated control dispatch strategy between CHP and WPP.

4.1 Automatic generation control

The AGC is used to routinely balance the power system and makes the power system operation more reliable [17]. In the CE, the AGC is used to maintain the tie line interchanges at their plan level [18], as in the western Danish power system.

The AGC developed and implemented in this investigation, for the eastern and western Danish power system, is sketched in Fig. 5. In each part of the Danish power system, AGC measures the frequency deviation (Δf) from its nominal level and the possible power mismatch (ΔP) between generations (CHP, DCHP and WPP) and power exchange with neighbouring power systems and system load. The sum of ΔP with the product of Δf and system frequency bias factor (B) is called the ‘area control error’ (P_{ACE}). B is determined from the droop characteristics of all generating units taking part in the primary response [20]. Equations (1) and (2) show the P_{ACE} and ΔP , respectively

$$P_{ACE} = \Delta P + (\Delta f \times B) \quad (1)$$

$$\Delta P = P_{Load} + P_{exchange} - P_G \quad (2)$$

As indicated in Fig. 5, the P_{ACE} is processed by a central controller, usually a proportional–integral (PI), which calculates the required change in production (ΔP_{sec}) for the power plants to bring the P_{ACE} to zero, that is

$$\Delta P_{sec} = K \times P_{ACE} + \frac{1}{T} \int P_{ACE} \quad (3)$$

where ‘ K ’ and ‘ T ’ are the gain and integration time constants, respectively, and are adjusted based on the recommendation from [21] for the CE power system. The ΔP_{sec} is then distributed using the ‘dispatch strategy’ block among the actively participating generators, namely CHP and WPP assumed in this paper. This dispatch thus decides the change in reference power for the generating units CHP and WPP, that is, ΔP_{CHP} and ΔP_{WPP} , by using as input signals ΔP_{sec} , CHP generation (P_{CHP}), WPP generation (P_{WPP}) and the available wind power (P_{WPP_avail}). Moreover, the dispatch strategy also takes into account the power generation limits (minimum and maximum) from the participating generating units.

4.2 Dispatch strategy between CHP and WPP

Traditionally conventional power plants provide the secondary frequency control in real-time operation. However, the increasing wind power integration may require active participation from WPPs in secondary frequency control in future power systems along with conventional power plants, as some conventional power plants might be replaced by WPPs. Coordinated AGC with dispatch between conventional power plants and WPPs is therefore

of high priority for operational security and stability. This can be achieved by taking into account the generation and available reserves capacity from all participating generating plants for the secondary power control.

In the present paper, the secondary dispatch between CHP and WPP is performed based on cost minimisation. The following set of equations decides the positive and negative secondary dispatches for the WPP and CHP, (4)–(9) (positive) and (10)–(14) (negative)

$$\text{minimise } C = C_{P_{WPP}} \Delta P_{WPP} + C_{P_{CHP}} \Delta P_{CHP} \quad (4)$$

∴ positive dispatch cost

Subject to

$$\Delta P \geq 0 \quad (5)$$

$$\Delta P_{CHP} \leq \Delta P_{CHP_UpLim} \quad (6)$$

$$P_{CHP} \leq P_{CHP_max} \quad (7)$$

$$\Delta P_{WPP} \leq P_{WPP_avail} - P_{WPP} \quad (8)$$

$$P_{WPP} \leq P_{WPP_avail} \quad (9)$$

$$\text{maximise } C = C_{P_{WPP}} \Delta P_{WPP} + C_{P_{CHP}} \Delta P_{CHP} \quad (10)$$

∴ negative dispatch cost

Subject to

$$\Delta P < 0 \quad (11)$$

$$\Delta P_{CHP} \geq \Delta P_{CHP_LowLim} \quad (12)$$

$$P_{CHP} \geq P_{CHP_min} \quad (13)$$

$$P_{WPP} \leq P_{WPP_min} \quad (14)$$

where $C_{P_{WPP}}$ is the power generation cost from WPP, $C_{P_{CHP}}$ is the power generation cost from CHP, P_{WPP_min} is the minimum generation level of WPP, P_{CHP_min} is the minimum generation of CHP and P_{CHP_max} is the maximum generation of CHP.

As mentioned in Section 3, the WPP will generate the available wind power ($P_{WPP} = P_{WPP_avail}$). Therefore, during positive secondary dispatch (4), only CHP will participate. However, during negative secondary dispatch, as $C_{P_{WPP}} \ll C_{P_{CHP}}$, the wind power is down regulated only when CHP is unable to follow AGC command. Otherwise, the WPP will generate its maximum available power. The assumption is useful for the situation when WPP is generating highly and the conventional power plants are running on their lower level. In this paper, the dispatch for CHP (ΔP_{CHP}) is limited to ± 90 MW, as is the case for the AGC acting on the border of western Denmark with Germany, and WPP can reach their minimum generation level and available wind power.

The secondary dispatch in this paper, based on the above equations, will be as follows: the WPP is down regulated only when the output of AGC is negative, that is, $\Delta P_{sec} < 0$, whereas the

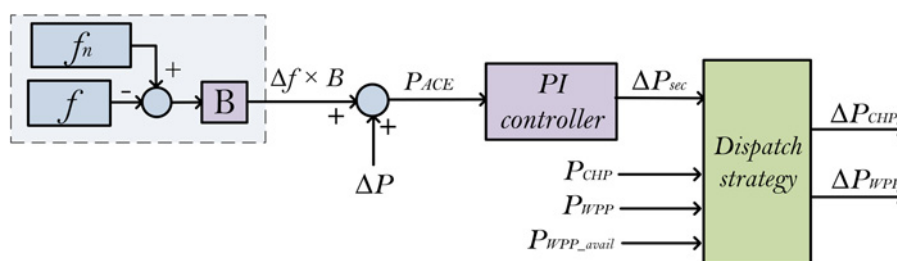

Fig. 5 AGC and dispatch strategy model – [19]

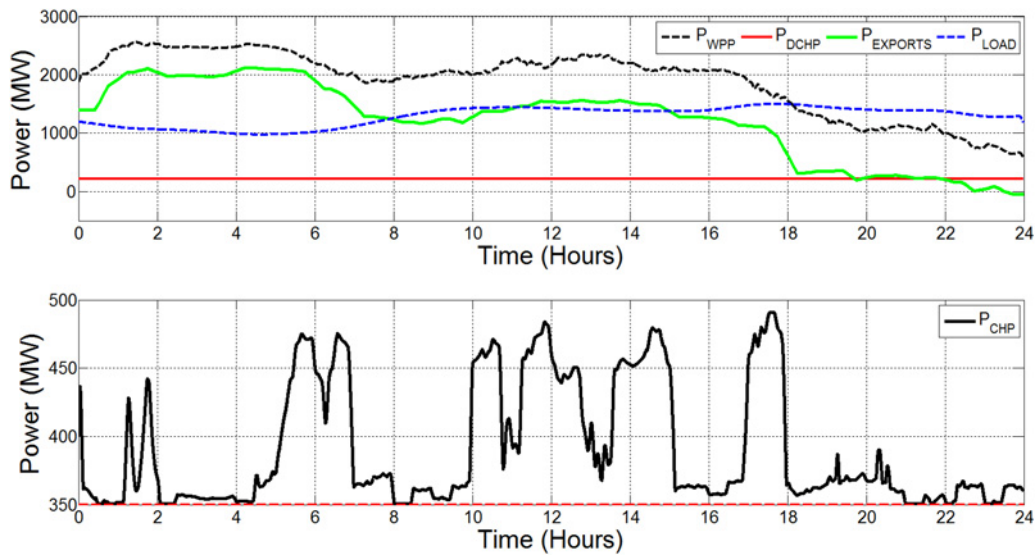

Fig. 6 Generation, load and power exports – eastern Danish power system

CHP provides secondary response for positive or negative value of ΔP_{sec} . For down regulation, the WPP will receive reference power signal only when CHP generation touches the lower generation limit (P_{CHP_min}) or ΔP_{sec} reaches to ΔP_{CHP_LowLim} , that is, -90 MW. However, in case of up regulation, that is, $\Delta P_{sec} > 0$, only the CHP provides the secondary support, as the WPP is already generating the available wind power.

5 Simulations and results

A set of simulations has been carried out to illustrate the dynamic performance of the proposed and implemented active power balanced control strategy, where wind power is directly integrated in the AGC control. The simulations are performed using the time series for generation, load and power exchange corresponding to one particular day of the year 2020 with high wind power. These time series are generated by the HA power balancing model (SimBa) for the Danish power system based on the real data from the year 2009. In this paper, the power exchange is kept at its planned level, whereas the reference powers of CHP and WPP are altered from the HA plan within the operating hour, as directed

by the AGC. The power generated within the operating hour by WPP and CHP in the eastern and western Danish power systems is shown in Figs. 6 and 7, respectively. These figures also show the load demand and the planned power exports with neighbouring power systems. The power exports with neighbouring power systems are calculated by subtracting the total import power from the total export power within their respective power systems.

From Figs. 6 and 7 it can be seen that the WPP is generating higher than the CHP. The online capacity of CHP in eastern and western Danish power systems on the particular day is 1754 and 1944 MW, respectively. CHP is frequently operating near the minimum operating point, that is, 20% of the online capacity, marked as dotted line in these figures. The higher production from WPP also permits positive power exports with neighbouring power systems.

Power mismatch between generation and load appears when the actual wind power generated within the operating hour differs from the HA forecast or when other unpredicted events take place in the power system, like generator failures or line loss. The generating unit responds to the power imbalance by releasing FRR through the AGC. Fig. 8 shows the power imbalance in the eastern and

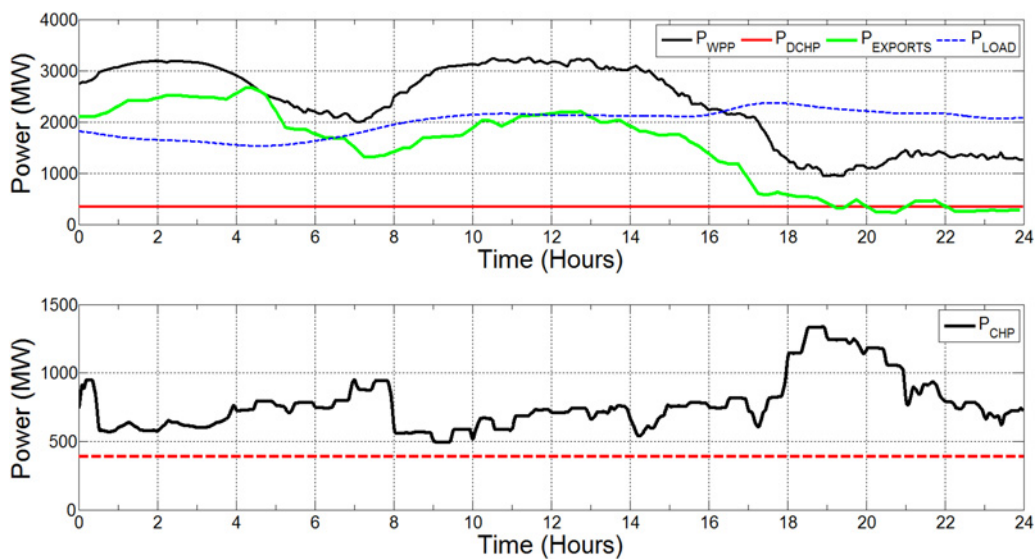

Fig. 7 Generation, load and power exports – western Danish power system

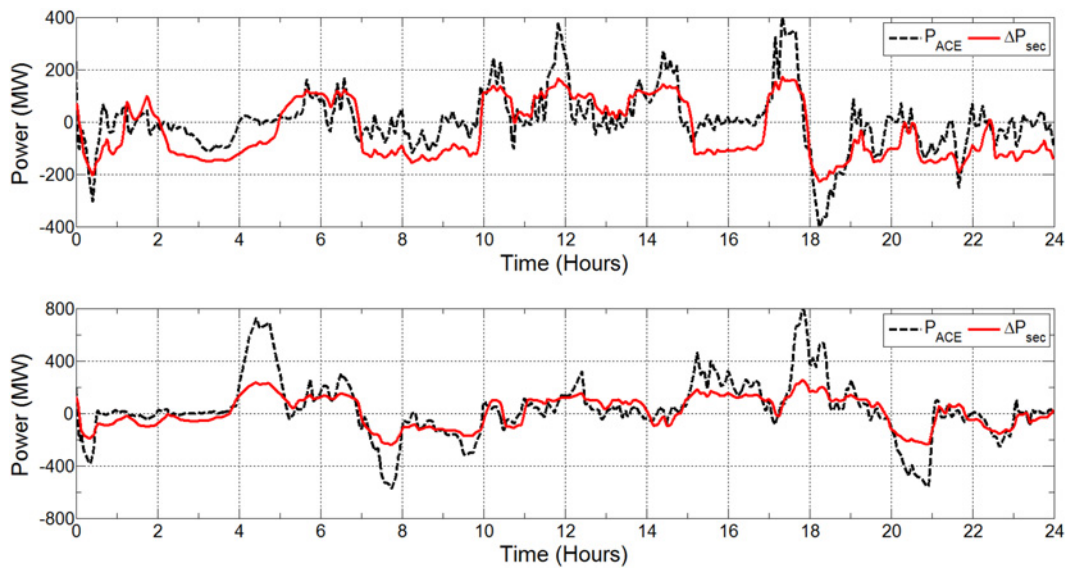

Fig. 8 P_{ACE} and ΔP_{sec} – top: eastern Danish power system; bottom: western Danish power system

western Danish power systems, reflected by the ACE signal, that is, P_{ACE} . As depicted in Fig. 5, the P_{ACE} is the input signal used in the PI controller of the AGC to decide the necessary secondary response (ΔP_{sec}) from the generating units to compensate for the power imbalance. As shown in Fig. 8, the ΔP_{sec} lags behind P_{ACE} because of the delays in the AGC system and the delays associated with the power plants response. These delays are because of the ramp in the reference power (i.e. 30 MW/min considered in this paper) and also because of the slow boiler response of CHP units (i.e. the boiler needs 5–6 min to modify its output pressure when demanded).

The new reference power signals for CHP and WPP are then determined by the dispatch strategy. The change in reference power signals for CHP and WPP in the eastern and western Danish power systems, calculated through the proposed dispatch strategy, is shown in Fig. 9. Note that WPP only participates in the down regulating process, whereas CHP contributes to both up and down regulating processes. The down regulating secondary dispatch to the WPP (ΔP_{WPP}) is activated only when CHP is unable to provide the required response. This simulation shows the strength of

the proposed coordinated AGC between WPP and CHP, namely that when the CHP dispatch (ΔP_{CHP}) touches the lower limit (–90 MW) or they are operating at their lower generation limit (20% of the online capacity), this being quite frequent, the WPP can actively help the AGC, and reduce the real-time power imbalance in the power system, by down regulating their power production. It is worth mentioning that on the particular day considered in the present investigation, out of the available wind energy in eastern and western Danish power systems of 46.6 and 56.93 GWh, respectively, 1.06 GWh and 320 MWh are spilled out in the down regulation of the WPP to compensate for the power imbalance. The amount of energy lost for maintaining power balance is thus 2.2 and 0.56% of the available wind energy in the hugely wind power integrated eastern and western Danish power systems, respectively, when CHP is not able to provide the required response. This shows that active participation of WPP in AGC is an attractive solution for future power systems with large scale of wind power.

Fig. 10 compares the initial power imbalance in the eastern and western Danish power systems with the power imbalance when secondary dispatch is controlled with AGC controlled CHP and AGC

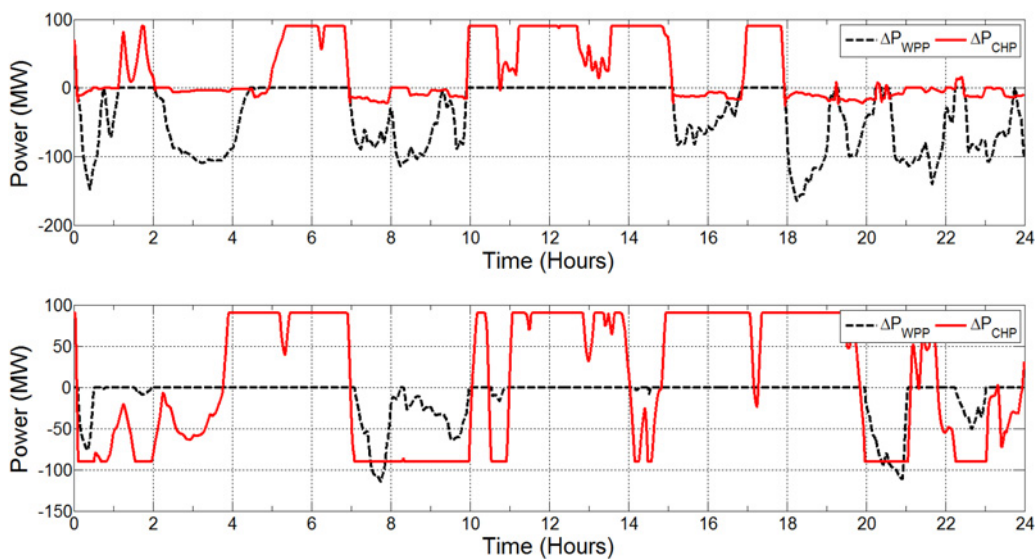

Fig. 9 ΔP_{CHP} and ΔP_{WPP} – top: eastern Danish power system; bottom: western Danish power system

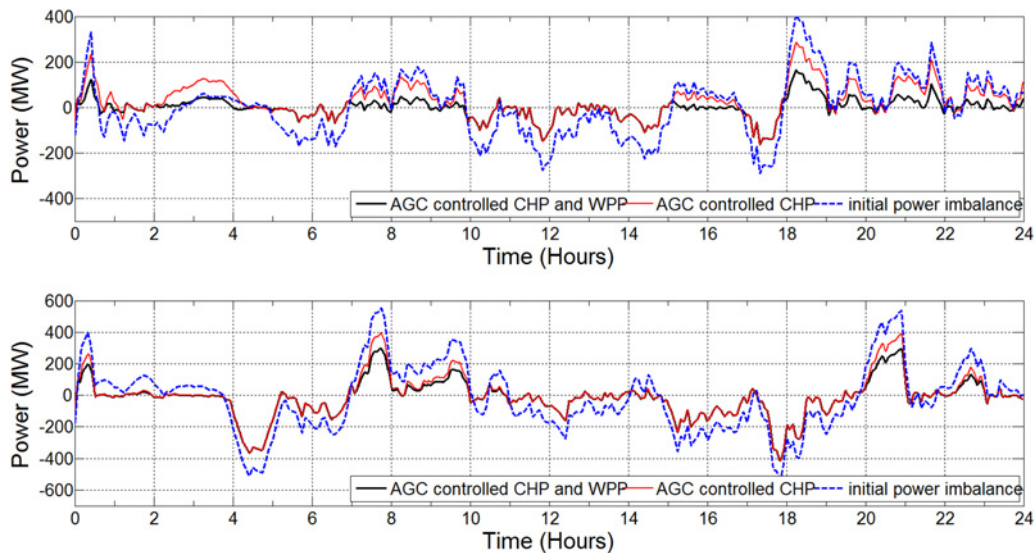

Fig. 10 Power imbalance – top: eastern Danish power system; bottom: western Danish power system

controlled CHP and WPP. It can be seen that without WPP integration, the power imbalance is larger in the case of generation excess than in the case with WPP, as CHP is frequently operating at the minimum level or ΔP_{CHP} reaching to its lower limit. The simulations show that the integration and active participation of WPP in the AGC system reduces the real-time power imbalances and makes power system operation more reliable.

6 Conclusion

This study proposes and presents a novel and practical approach for integration of wind power into the AGC of power systems to compensate the power imbalances between demand and generation in real time, provoked by wind power forecast errors. It is based on a coordinated control strategy between CHPs and WPPs. The Danish power system, with high wind penetration corresponding to year 2020 scenarios, is used as a case study in the verification of the proposed method. The new control methodology for the AGC system with WPPs integrated is using input time series from a power balancing model on power generation, power demand and power exchange with the neighbouring systems. Study with high wind penetration scenarios, corresponding to one particular day with high wind speed in 2020, is performed and presented in order to illustrate how power imbalances between demand and generation can be compensated by regulating the active power production from conventional and WPPs.

The present investigation shows that the active integration of wind power into the dispatch of the AGC is an attractive active power balancing control solution for power systems with large-scale wind power penetration. The strength of the solution is of high relevance, particularly in situations when wind power is contributing with large portion of the total electricity production and when the conventional power plants are operating at the minimum level and cannot be further down regulated in case of generation excess. The down regulation of the wind power reduces the power imbalance in real-time operation and because of its fast ramp rates can also provide quick ACE compliance. Furthermore, a good forecasting of wind speed and load demand and an increased automatic generation controller capacity, are always important for a secure and reliable power system operation of a large-scale wind power integrated power system. Further research can also investigate the programmed control of regulating bids in real time to enhance the secure and reliable power system operation for highly integrated wind power scenarios.

7 Acknowledgment

This paper is a part of Ph.D. project funded by the Sino-Danish centre for education and research (SDC).

8 References

- [1] Gao W., Wu Z., Wang J., Gu S.: 'A review of inertia and frequency control technologies for variable speed wind turbines'. 25th Chinese Control and Decision Conf. (CCDC), Guiyang, 2013
- [2] Sun Y.Z., Zhang Z.S., Li G.J., Lin J.: 'Review on frequency control of power systems with wind power penetration'. Int. Conf. on Power System Technology (POWERCON), IEEE, 2010
- [3] Doherty R., Mullane A., Nolan G., Burke D.J.: 'An assessment of the impact of wind generation on system frequency control', *IEEE Trans. Power Syst.*, 2010, **25**, (1), pp. 452–460
- [4] Ummels B.C., Madeleine G., Kling W.L., Paap G.C.: 'Performance of automatic generation control mechanisms with large-scale wind power'. Nordic Wind Power Conf., 2007
- [5] Bi Hui L., Hong S., Yong T., Hongyun Z., Feng S., Dong Fu L.: 'Study on the frequency control method and AGC model of wind power integration based on the full dynamic process simulation program'. Int. Conf. on Power System Automation and Protection (APAP), IEEE, Beijing, 2011
- [6] Aho J., Bucksan A., Pao L., Fleming P.: 'An active power control system for wind turbines capable of primary and secondary frequency control for supporting grid reliability'. Proc. 51st AIAA Aerospace Sciences Meeting Including the New Horizons, January 2013
- [7] Antonishen M.P., Hai H.Y., Brekken T.K.A., *ET AL.*: 'A methodology to enable wind farm participation in automatic generation control using energy storage devices'. Power and Energy Society General Meeting, IEEE, San Diego, CA, 2012
- [8] Zhu J., Cheung K.: 'Analysis of regulating wind power for power systems'. Power & Energy Society General Meeting, IEEE, Calgary, AB, 26–30 July 2009
- [9] Vittrup C.: '2013 was a record-setting year for Danish wind power'. Energinet.dk, 15 January 2014. [Online]. Available at <http://www.energinet.dk/EN/El/Nyheder/Sider/2013-var-et-rekordaar-for-dansk-vindkraft.aspx>, accessed 06 February 2014
- [10] Skødt T.: 'Electricity interconnections'. Energinet.dk, 20 February 2014. [Online]
- [11] Basit A., Hansen A.D., Sørensen P.: 'Dynamic model of frequency control in Danish power system with large scale integration of wind power'. China Wind Power (CWP) Conf., Beijing, 2013
- [12] Working Group on Prime Mover and Energy Supply Models for System Dynamic Performance Studies: 'Dynamic models for fossil fuelled steam units in power system studies', *IEEE Trans. Power Syst.*, 1991, **6**, (2), pp. 753–761
- [13] IEEE Committee Report: 'Dynamic models for steam and hydro turbines in power system studies', *IEEE Trans. Power Appar. Syst.*, 1973, **PAS-92**, (6), pp. 1904–1915

- [14] CIGRE Task Force 25 of Advisory Group 02 of Study Committee C4: 'Modeling of gas turbines and steam turbines in combined cycle power plants'. CIGRE, 2003
- [15] IEC 61400-27 Committee Draft, Wind Turbines Part 27-1: 'Electrical simulation models for wind power generation Wind turbines'. IEC Std. committee Draft (CD) 88/424/CD, 2012
- [16] Grande O.S., Doorman G., Bakken B.H.: 'Exchange of balancing resources between the Nordic synchronous system and the Netherlands/Germany/Poland'. SINTEF, 2008
- [17] ENTSO-E: 'Continental Europe Operation Handbook – p1: load-frequency control and performance', [Online]. Available at <https://www.entsoe.eu/publications/system-operations-reports/operation-handbook/>, accessed September 2013
- [18] Hamon C.: 'On frequency control schemes in power systems with large amounts of wind power' (KTH School of Electrical Engineering, Stockholm, 2012)
- [19] Gjengedal T.: 'System control of large scale wind power by use of automatic generation control (AGC)'. Quality and Security of Electric Power Delivery Systems, 2003.CIGRE/PES 2003. CIGRE/IEEE PES Int. Symp. 8–10 October 2003, vol., no., pp. 15–21
- [20] Prabha K.: 'Power system stability and control' (McGraw-Hill, 1994)
- [21] Rebours Y.G., Kirschen D.S., Trotignon M., Rossignol S.: 'A survey of frequency and voltage control ancillary services – part i: technical features', *IEEE Trans. Power Syst.*, 2007, **22**, (1), pp. 350–357

P 2: Basit A.; Hansen A. D.; Altin M.; Sørensen P.; Gamst M.: “Compensating Active Power Imbalances in a power system with high wind power penetration” Submitted to Journal of modern power system and clean energy

Compensating active power imbalances in a power system with high wind power penetration



A. Basit, A.D. Hansen, M. Altin, P. Sørensen and M. Gamst

Abstract Large scale wind power penetration may affect the supply continuity in the power system. This aspect is a matter of high priority to investigate, as more regulating reserves and specified control strategies for generation control are required in the future power system with even more high wind power penetration. The emphasis in this article is on the evaluation of the impact of large scale integration of wind power on future power systems. The present work proposes an active power balance control methodology for compensating the power imbalances between demand and generation in real time, caused by wind power forecast errors. This methodology, which can be applied for the balance power control of future power systems with large scale wind power integration, is described and exemplified considering the generation and power exchange capacities in the year 2020 for Danish power system.

Keywords Wind Power Plant (WPP), SimBa, centralised or de-centralised combined heat and power plant (CHP or DCHP), Automatic Generation Control (AGC)

1 Introduction

The foremost task of any transmission system operator (TSO) is to maintain a reliable and secure power system operation and afterwards to minimize the production cost, even in conditions with high wind power penetration. The wind speed forecast in a heavily wind power integrated

power system plays an important role in the power balance planning. An incorrect wind speed forecast might deviate the generation and the power exchange plan with neighbouring power systems from the cost effective calculated schedule. This fact can lead to power system balancing and control problems and can introduce several challenges in maintaining a reliable and secure power system operation [1]. In spite of these challenges, the interest in the integration of large wind power into power systems has motivated and enhanced new opportunities in modelling and control of power system research. Adequate methodologies for studying power system dynamics and control, like the present one, on the active power balance control, are of high relevance for the future power systems.

Several studies on active power balancing in a large scale wind power integrated power system have been performed and presented in the literature [2 – 5] over the years. In [2], the performance of the secondary control action and the regulating power control from conventional power plants is analysed, while in [3] it is stated that response of the thermal power plants used in power balance control is mainly determined by their active power ramp rate. In [4], where a Dutch case study is described to assess the Automatic Generation Control (AGC) performance in the presence of large scale wind power and it is concluded that additional reserves from thermal power plants are required for keeping the area control error at the same level. Recent Chinese studies [5] have led to the conclusion that, the power imbalances from wind power plants (WPPs) can be controlled via conventional generators. Nevertheless, further studies and control methodologies for balancing the active power in power systems with large scale wind power integration, taking into account hour-ahead dispatch power plan for generating plants and power exchange with neighbouring power systems, are necessary to enhance the stability of future power systems with high wind power penetration. In this respect, conventional market models are important to be considered as well, as they are simulating optimal unit commitment and dispatch of power plants with one hour resolution [6]. However, in

Received: 12 September 2014 / Accepted: 20 January 2015

A. Basit, A.D. Hansen, M. Altin and P. Sørensen: Technical University of Denmark, Department of Wind Energy, Frederiksborgvej 399, 4000 Roskilde, Denmark

A. Basit, Sino-Danish Center for Education and Research, Niels Jensens Vej 2, 8000 Aarhus, Denmark

M. Gamst, Energinet.dk, Tonne Kjærvej 65, 7000 Fredericia, Denmark

✉ e-mail: abdl@dtu.dk



order to manage the wind power forecast errors in a large scale wind power integrated power system, a dispatch plan for the power plants with a smaller resolution than one hour is necessary.

In a large interconnected power system, power balance is one of the main challenges that need to be evaluated for large scale integration of wind power. The objective of this article is to present a new methodology for active power balance control for future interconnected power system with large scale wind power penetration. The novelty of this work is that the proposed control methodology uses an hour-ahead regulating power plan in a time scale of five minutes to compensate the real time active power imbalances in the power system. This methodology can be used as a guideline for the TSOs, to investigate their power balancing capabilities considering WPPs. The Danish power system is used for the implementation and verification of this methodology because of its big wind power penetration goal quote, i.e. 50% of the total electricity production from wind power by 2020 [7].

The article is structured as follows. A brief description of the impact of the fluctuated nature of the wind on the power system operation is provided first. Then the proposed active power balance control methodology is described, approaching also the aspects regarding the AGC and the generation of the hour-ahead regulating power plan. The high wind penetration scenarios for the Danish power system in year 2020 are used to assess the performance of the methodology through a set of simulations with the developed Danish power system model. Finally, conclusive remarks are reported in the final section.

2 Wind power impacts on power system operation

Wind speed is always fluctuating and so is the power generated from wind turbines (WTs). The fluctuating and uncertain nature of wind may introduce several challenges in the maintenance of the power balance in a power system with large wind power integration. No matter what, the TSOs have the responsibility to preserve a reliable power system operation and ensure a secure power supply, while keeping the generation at lowest possible cost.

Active power reserves are always needed to keep the power system in balance and their amount depends also on the level of wind power penetration into the power system and on forecasted weather conditions. For example, extreme weather conditions may result in loss of large amount of wind power within few minutes, jeopardizing the reliability and the security of the power system operation [1]. Therefore reserves are typically needed from fast conventional generating units to increase the system reliability and to ensure the power supply security. According to European Network of Transmission System

Operators for Electricity (ENTSO-E), the type of reserves needed to keep the power system in balance can be classified as Frequency Containment Reserves (FCR), Frequency Restoration Reserves (FRR) and Replacement Reserves (RR) [8, 9]. FCR are activated automatically and locally within 30 seconds for constant containment of frequency deviations and to constantly maintain the power balance in the whole synchronously interconnected system. FRR are typically activated (manually or automatically) within 15 minutes, in order to maintain the active power balance in the power system and the power exchange with neighbouring power system at its schedule. RR responds in several minutes up to hours and restores the FCR and FRR back to the required level. The total volume of FCR in Continental Europe and Nordic region is ± 3000 MW and ± 600 MW, respectively [9]. However, as wind power impacts the power system operation, it is predicted that more reserves will be needed in the future to accommodate large amount of wind power into the power systems. In this study power imbalance is controlled through FCR and FRR. Conventional and wind power plants provides the FCR, while FRR is activated only from conventional power plants through AGC.

3 Active power control methodology

A methodology to control the active power imbalance in a large scale wind power integrated power system is presented in this study. The proposed methodology uses an hour-ahead regulating power plan in a time scale of five minutes for the power plants and power exchange with neighbouring power systems. The following subsections explain the generation of hour-ahead regulating power plan by a balancing program and the AGC model developed for this study.

3.1 Hour-ahead regulating power plan

The generated power in a power system is typically traded by the balancing responsible companies on the spot-market [7]. Two standard power balancing programs, namely WILMAR and SimBa, are used in the present work to generate the day-ahead and hour-ahead time series. WILMAR stands for 'Wind Power Integration in Liberalised Electricity Markets', while SimBa stands for Simulation power Balancing. A detailed description of these programs is out of the scope of the present work. However, more details on WILMAR and SimBa can be found in [10 – 13] and [7 & 14], respectively.

The WILMAR is an example of a program used to model the spot market as a perfect market with a unit commitment and dispatch model. The hourly bids for purchase and sale are selected one day prior to physical delivery and therefore referred as a day-ahead market. Within this process, the bids are selected with foremost

intent of preserving system integrity and then to minimize the overall operating cost. The bids selection is subjected to different constraints, such as transmission constraints in the electricity system and capacity constraints of storage and generating technologies.

The balance day-ahead agreements come out of balance because of wind power forecast errors or unavailability of generating units. The power balance can then be restored by trading on an intra-day balancing power market. For example, based on updated forecasts, the Danish TSO uses the Nordic Operational Information System (NOIS) list and generates an hour-ahead plan for the intra-hour balance with five minute resolution, through simulations with a dedicated power balancing program, known as SimBa [7 & 14]. SimBa models the power system in detail, taking the current grid regulations and the energy market rules continuously into account. It uses inputs from unit commitment models including hourly values for energy production, load and the power exchange between interconnected areas. These inputs to the SimBa program are provided by WILMAR model, while Correlated Wind power fluctuations (CorWind) model provides the day-ahead and hour-ahead forecasts of wind power and the available wind power.

With the balanced hourly time series provided by WILMAR, SimBa starts to update the day-ahead schedule with a five-minute time resolution taking in account the ramping on interconnection lines and power plants. It then estimates the fluctuations from hour-ahead wind power forecast and generates the possible wind power schedule in a five minute resolution within the operating hour. Based on the possible wind power schedule and the updated day-ahead schedule, SimBa calculates the mean imbalance for half an hour and balances the power system internally in different areas, considering the grid regulation, transmission losses and transmission constraints. It activates the bids from NOIS list, while taking in account the minimum activation time (30 minutes) and minimum bid level (10 MW) [14]. With above mentioned constraints, SimBa then provides the balanced hour-ahead plan for generating units and power exchange with neighbouring power systems with five minute resolution. Figure 1 illustrates how SimBa, based on the inputs from CorWind and WILMAR generates the hour-ahead input to the dynamic power system model, where the AGC is acting.

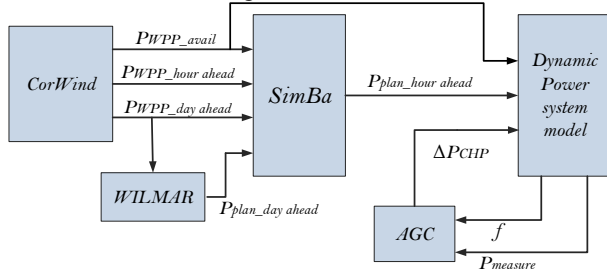

Figure 1: Overview of the signals between CorWind, WILMAR, SimBa, the dynamic power system model and the AGC

SimBa creates an upward and downward regulation list of bids based on the marginal cost function, bidding price and production capacity for each unit. Due to the uncertain nature of wind, the wind power within the operating hour may not be the same as its estimated value and this aspect can create power imbalance within the operating hour. This imbalance is partially compensated by FRR, i.e. through activation of additional regulating bids in the control room from the NOIS list and with an AGC having reserved capacity of ± 90 MW acting on the border of Western Denmark with Germany [7]. However, for the present investigation, it is assumed that the power imbalance within the operating hour is controlled only through AGC, by providing ΔP_{SET} to the conventional power plant (i.e. centralised combined heat and power plant (CHP)) as a secondary response.

3.2 Automatic Generation Control (AGC)

The AGC is used to routinely balance the power system and to make the power system operation more reliable [15]. The AGC, developed and implemented in this investigation, is sketched in Figure 2. The goal of the AGC, depending on available secondary power, is to reduce the area control error (P_{ACE}) to zero. The P_{ACE} is calculated based on the change in system frequency (Δf) and on a possible power mismatch (ΔP) between generations, power exchange and system load, as follows:

$$P_{ACE} = -\Delta P - (\Delta f \times B) \tag{1}$$

$$\Delta P = P_G - P_{exchange} - P_{Load} \tag{2}$$

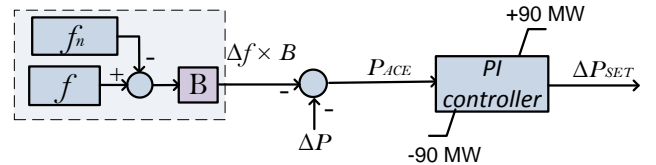

Figure 2: AGC model

where, P_G is the power generated by CHPs, de-centralised combined heat and power plant DCHPs and WPPs in real time. The system frequency bias factor B [MW/Hz] is determined from the droop characteristics of all generating units taking part in the primary response. The frequency bias factor is reflecting the power ability (and thus FCR) of the generating units to compensate for a frequency changes. The overall secondary response from AGC, i.e. ΔP_{SET} , is decided by a PI controller based on the equation shown below, where K and T are the gain and integration time constant, respectively:

$$\Delta P_{SET} = K \times P_{ACE} + \frac{1}{T} \int P_{ACE} \tag{3}$$

ΔP_{SET} represents the required change in the participating generating power set points in the imbalanced area. In this study, an AGC with a capacity of ± 90 MW is implemented to investigate the impact of large scale integration of wind power on future power systems during power imbalances between demand and generation,

caused by wind power forecast errors. The wind power is not integrated in AGC in the present study, as this is a part of the next upcoming investigation.

4 Simulation based validation of the methodology

As mentioned before, the Danish power system is used to validate the performance of the proposed active power control methodology. The following sub-sections will explain the future Danish power system model and a set of simulations assessing the performance of the proposed active power control methodology.

4.1 Danish power system case study

The developed Danish power system model reflects the most relevant dynamics of the power system with respect to active power balancing control issues. It includes models for the AGC system, centralised or de-centralised combined heat and power plant (CHP and DCHP), WPP and interconnections with neighbouring power system.

As the focus of this investigation is on active power balance control, the transmission losses are ignored and the power system is designed as a two bus system, shown in Figure 3. The system interconnections and the generating unit models in the Danish power system are shortly explained below.

4.1.1 System interconnection

The Danish power system is composed of two power systems, i.e. Eastern and Western Danish power systems. They are connected together through an HVDC connection, i.e. Great Belt Link (GBL) having a transmission capacity of 600 MW. They are also connected to the strong neighbouring power systems of Germany, Sweden and Norway. The Eastern Danish power system is synchronized with the Nordic power system, whereas the Western Danish power system is synchronized with the continental European power system. The interconnection capacities of Danish power system with its neighbouring powers as planned for the year 2020 are shown in Figure 4 [16], where AC interconnections are presented as dotted line and DC interconnections as solid lines.

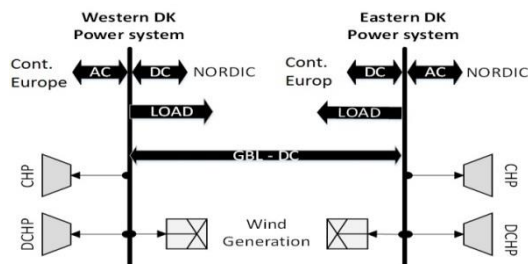

Figure 3: Danish power system model overview

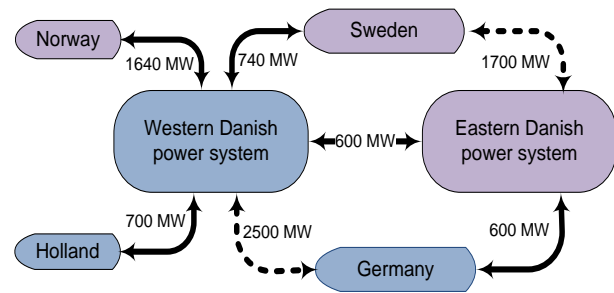

Figure 4: Denmark interconnection capacities as planned for 2020

Denmark's neighboring power systems ramp the agreed power exchange in different durations and at different starting times. For example, in the Nordic power system, the agreed power exchange shall be ramped within 30 minutes and shall begin 15 minutes before the agreed exchange hour. Meanwhile, in the continental European power system, the power exchange shall be ramped within 10 minutes and shall start 5 minutes before the agreed exchange hour [15]. If the power has to be transported from the Nordic power system to the continental European power system or vice versa, the difference in power exchange ramping might lead to a power imbalance in Danish power system at an agreed hour.

4.1.2 Electrical power generating units

The electrical power generation in Denmark is a combination of conventional and renewable generation sources. The conventional power generation is typically based on CHPs and DCHPs, while renewable generation is basically from WPPs. In the following, aggregated models of power generating units used in the Danish power system, reflecting their most relevant dynamic features, are briefly described.

A. Conventional power plants

Aggregated models for CHP and DCHP are frequently described in the literature [17 – 18]. It is worth mentioning that, the response time and ramp rates associated with CHP are in order of minutes and they are the dominant characteristic for power system studies. Shortly, an aggregated CHP model consists of a thermal boiler, a boiler turbine controller, a steam turbine and a speed governor, while, an aggregated DCHP model includes gas turbine and a speed governor.

In the proposed methodology, the reference power signal for CHP or DCHP is calculated based on the planned power from SimBa and the power correction from the AGC. The speed governor of the generating units activates the FCR, if the frequency deviates by ± 0.01 Hz. The amount of activated FCR depends on the droop characteristic of the governor of each generating unit (i.e. 4% in this study).

B. Wind Power plant

The aggregated modelling of WPP is commonly used to facilitate power system studies, where the concern is not on the performance of an individual WT, but rather on the impact of an entire WPP on the power system. The idea of using the aggregation method is to reduce computational effort, while maintaining the capability to predict unit influence on system dynamic behaviour. A simplified generic aggregated WPP model is therefore developed in this work for long term dynamic simulation studies, with starting point from the IEC61400-27-1 Committee Draft for electrical simulation models for wind power generation [19]. However, for the specific purpose of this study, the model is further simplified and adjusted to be able reflect correctly the dynamic features for active power and frequency control capability studies, i.e. primary control from WPP.

The aggregated WPP model, shown in Figure 5, has a hierarchy structure, namely that there is WPP active power control level and a WT active power control level. The power reference P_{ref} to the WT active power controller is generated by the WPP active power controller, based on the primary response signal (ΔP_c), the available wind power signal (P_{WPP_avail}) from the power balancing model and the measured power in the Point of Common Connection (PCC). As illustrated in Figure 5, the control both in the WT and in the WPP level is realised by using PI controllers. For example, the PI controller in the WPP active power controller reduces the error between measured power at PCC (P_{meas_PCC}) and the sum between the available power and the primary response signal (P_{WPP_avail} & ΔP_c), in the decision of the Pref.

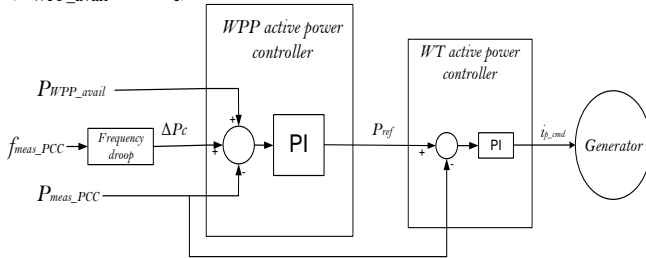

Figure 5: Aggregated WPP model

The frequency droop block in Figure 5, decides the ΔP_c for the aggregated WPP model, based on the droop setting. The typical value of 4% is used in this work for the droop setting. The primary response capability of WPP is however strongly dependent on the availability of reserve power. Figure 6 shows for example the dynamic primary response from the WPP with a nominal power of 2800 MW, when a negative load step results in a frequency change of -0.034 Hz.

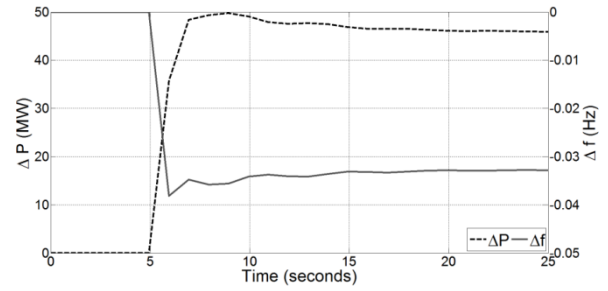

Figure 6: WPP primary response for a load step

The new steady state response from the WPP is then calculated as following:

$$\Delta P = -\Delta f \times \beta \tag{4}$$

Where,

$$\beta = \frac{P_{WPP_nominal}}{R \times f} = \frac{2800}{0.04 \times 50} = 1400 \text{ MW/Hz} \tag{5}$$

$$\rightarrow \Delta P = -\Delta f \times \beta = -(-0.034) \times 1400 = 47.6 \text{ MW} \tag{6}$$

Thus following a load step, the WPP shares a load of 47.6 MW by increasing its production in order to stabilize the system frequency.

4.2 Simulations and Results

Different studies are carried out in the following to assess the performance of the proposed active power control methodology. A set of simulations are performed using time series for generation, load and power exchange corresponding to one particular winter day. The time series are generated by SimBa for the scenario of the year 2020 for the Danish power system based on the real data from the year 2009. It is assumed that, the power exchange is kept at its planned level within the operating hour, while the conventional generating units change their power set point from planned schedule as directed by AGC for any power imbalance. The power generated within the operating hour from conventional and wind power plants, as well as the net exports with neighbouring power systems and the load demand in the Eastern and Western Danish power systems are shown in Figure 7 and Figure 8, respectively. The net exports are calculated by subtracting the total import power from total export power.

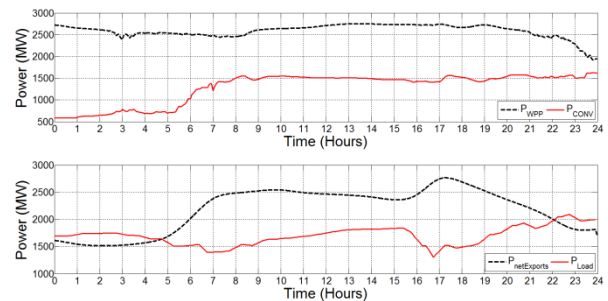

Figure 7: Generation, load and net exports within the operating hour – East Denmark

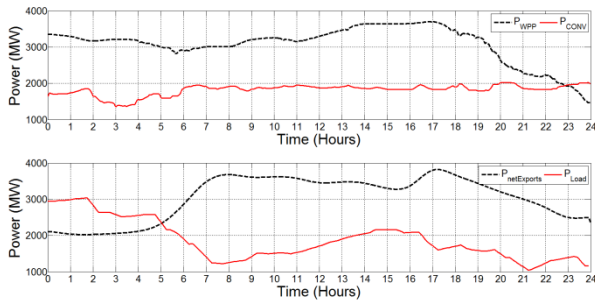

Figure 8: Generation, load and net exports within the operating hour – West Denmark

Notice that, on the considered day, the availability of wind allows the WPPs to generate more power than conventional power plants. In Eastern Denmark, the conventional power plants generated 30.81 GWh of electricity, while WPPs generated 62.17 GWh, i.e. 66.85% of the total electricity production. The high production from WPPs allows the net exports of 40.533 GWh from Eastern Danish power system, when the load demand was 52.422 GWh. Alike in Western Denmark, 43.83 GWh is generated from conventional power plants and 73.97 GWh from WPP, i.e. 62.8%. While, the total load demand and the net exports are 73.075 GWh and 44.612 GWh, respectively. The generation from WPPs can meet the load demand in Eastern and Western Danish power systems, but the conventional power plants are operating to uphold the system reliability in case of unforeseen events. The availability of wind power and the high load demand, in the large scale wind power integrated power system, motivates to investigate the system behaviour on this particular day.

As aforementioned in Denmark, the electricity markets are balanced taking in account the hour-ahead forecasts of wind and load. If the available wind power generated within the operating hour differs from the forecast, a power mismatch between generation and load will appear. The power mismatch yields to a change in the system frequency and deviation in power exchange from its hour-ahead schedule. The generating units equipped with speed governors will respond to the deviations by releasing FCR. Afterwards, the FRR from the AGC, depending on reserves availability, will return the system frequency to its nominal level and consequently replaces FCR.

Figure 9 shows for example the governor response from the WPP and conventional power plants (CHP+DCHP) as a result of wind power forecast error in Eastern and Western Danish power system respectively, while Figure 10 shows the area control error (P_{ACE}) after the AGC response (ΔP_{SET}) in these power systems. The governor response depends on their droop setting and also on their generating capacity. The WPP and the conventional power plants have the same droop setting, but the response is higher in case of WPP owing to its higher generation capacity, as illustrated in Figure 9. However, the activation

of FCR is subjected to reserves availability. These reserves are activated within 30 seconds and continue to be activated, as the power imbalance is changing continuously, until FRR through AGC removes the power imbalance.

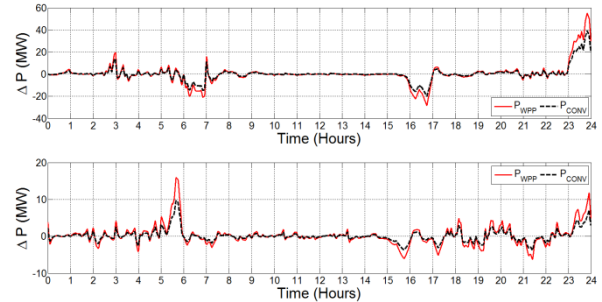

Figure 9: Governor Response to power imbalance – top: Eastern Denmark, bottom: Western Denmark

The AGC continuously respond to the power mismatch between generation and load by providing new power set point to the generating unit and tries to reduce the power imbalance (P_{ACE}) in the power system. However, the power imbalance in these power systems does not always return to zero level, as ΔP_{SET} is limited to ± 90 MW and also lags behind P_{ACE} due to the delays associated with the AGC and CHP, which abstains them to change their output at the required rate i.e. P_{ACE} rate. These delays are caused due to the ramp in the reference power considered in this study (i.e. 30 MW/min) and also due to the slow boiler response of CHP units (i.e. the boiler needs 5 – 6 minutes to modify its output pressure when demanded). The power imbalances deviates the system frequencies from their nominal level, as shown in Figure 11 for the Eastern and Western Danish power systems.

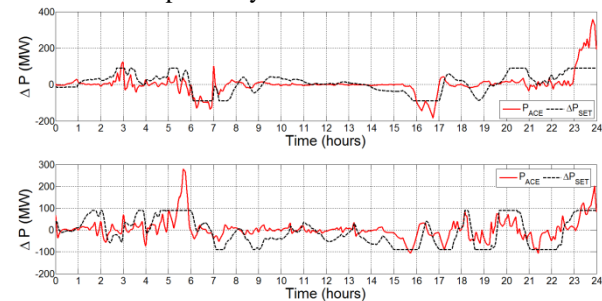

Figure 10: P_{ACE} and ΔP_{SET} from AGC – top: Eastern Denmark, bottom, Western Denmark

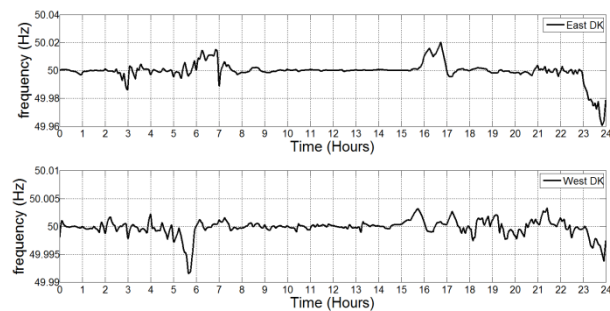

Figure 11: System frequency

The system frequency deviation illustrated in Figure 11 relates to the amount of power imbalance. The surplus power results in frequency rise, while the deficit in frequency drop. Notice that, in spite of a large power imbalance, as illustrated in Figure 12, the deviation in system frequency from its nominal level is insignificant, as the Danish power system is synchronously connected to stiff and large continental European and Nordic power systems. The strong neighbouring interconnections offer huge frequency bias and stabilize the frequency in Danish power system. However, the power imbalance will divert the power exchange from its schedule and may overload the tie line. The secondary support from AGC will lower the power imbalance in real time arising due to the wind power forecast error. Figure 12 compares the power imbalance in the Eastern and Western Danish power systems with and without AGC support. The simulations show that the AGC system reduces the real time power imbalances and makes power system operation more reliable.

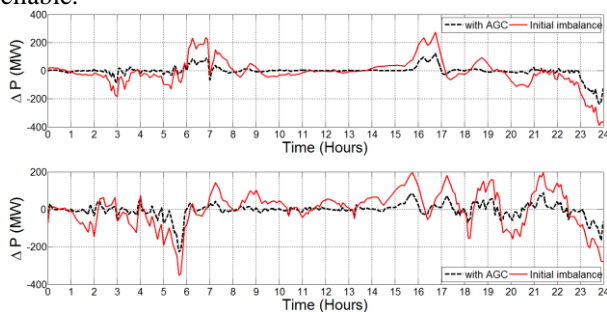

Figure 12: Power imbalance with and without AGC – top: Eastern Denmark, bottom: Western Denmark

5 Conclusion

The integration of large amount of wind power into future power systems presents several challenges, as for example the power system balancing and the availability of the regulating reserves. This article describes and analyses the challenges in the future power systems with the large scale integration of wind power. It proposes a methodology for the active power balance control taking in account the hour-ahead regulating power plan with reduced planning horizon, dispatching the power plants and the power exchange in a time scale of five minutes. The hour-ahead plan efficiently addresses the intermittent wind power and reduces the regulation burden that would be required in a dispatch plan of one hour. The AGC further compensates the power imbalances between demand and generation in a real time, provoked by wind power forecast errors. The Danish power system is used as a case study in the verification of the proposed method. The studies performed and presented in this article illustrate how imbalances between demand and generation can be compensated with reduced dispatch plan and by regulating the active power production from conventional power

plants through AGC.

It has been illustrated through a set of simulations that the AGC can effectively control the real time power imbalances due to the wind power forecast errors, by controlling the generation from conventional power plants. Furthermore, it has been seen that the regulating reserves are needed from fast conventional power plants to maintain system balance and the amount depends on the level of wind power integration. Better forecasting of wind speed and the load demand is desirable in a large wind power integrated power system. It has also been depicted that the interconnections with strong electrical networks stabilizes the system frequency and decides the wind power integration level.

The proposed methodology in this article provides guidelines on how large wind power can be integrated in the planning, control and operation of future power system. Further research can also investigate the WPPs participation in secondary frequency regulations by integrating the WPP control in the AGC system, to ensure secure and reliable operation of a large scale wind power integrated power system. Another topic for future investigation might be to find the cost effective solution to deal with larger power imbalance in a large scale wind power integrated power system.

6 Acknowledgement

This paper is a part of PhD project funded by Sino-Danish centre for education and research (SDC).

References

- [1] Suwannarat A, "Integration and Control of Wind Farms in the Danish Electricity System," Institute of Energy Technology Aalborg University, Aalborg, 2007.
- [2] Suwannarat A, Bak-Jensen B, Chen Z, Nielsen H, Hjerrild J, Sørensen P and Hansen AD, "Power System Operation with Large Scale Wind Power Integration," in IEEE Power Tech, Lausanne, 2007.
- [3] Egido I, Fernández-Bernal F, Rouco L, Porrás E, and Sáiz-Chicharro A, "Modeling of Thermal Generating Units for Automatic Generation Control Purposes," IEEE Transactions on Control Systems technology, vol. 12, no. 1, January 2004.
- [4] Ummels BC, Gibescu M, Kling WL and Paap GC, "Performance of Automatic Generation Control Mechanisms with Large-Scale Wind Power," in Nordic Wind Power Conference, 2007.
- [5] BiHui L, Hong S, Yong T, Hongyun Z, Feng S, and Dongfu L, "Study on the frequency control method and AGC model of wind power integration based on the full dynamic process simulation program," in International Conference on Power System Automation and Protection (APAP), IEEE, Beijing, 2011.
- [6] Sørensen P, Norheim I, Meibom P and Uhlen K, "Simulations of wind power integration with complementary power system planning tools," Electric Power Systems Research, p. 1069–1079, 2007.
- [7] Basit A.; Hansen A. D.; Altin M.; Sørensen P.; Gamst M.: 'Wind power integration into the automatic generation control of power



- systems with large-scale wind power', *The Journal of Engineering*, 1 (1), DOI: 10.1049/joe.2014.0222, IET Digital Library, <http://digital-library.theiet.org/content/journals/10.1049/joe.2014.0222>
- [8] Abbad JR, "Electricity market participation of wind farms: the success story of the Spanish pragmatism," *Energy Policy*, vol. 38, no. 7, p. 3174–3179, 2010.
- [9] Grande OS, Doorman G and Bakken BH, "Exchange of balancing resources between the Nordic synchronous system and the Netherlands / Germany / Poland," SINTEF, 2008.
- [10] Meibom P, Morthorst PE, Nielsen LH, Weber C, Sander K, Swider D, Ravn H, "Power System Models - A Description of Power Markets and Outline of Market Modelling in Wilmar," Risø-R-1441, 2003.
- [11] Meibom P, Barth R, Norheim I, Ravn H, Sørensen P, "Final Technical Report - Wind Power Integration in a Liberalised Electricity Market," Risø National Laboratory, January 2006.
- [12] Barth R, Weber C, "WILMAR, Deliverable D7.1 - Distribution of the integration costs of wind power," Institute of Energy Economics and the Rational Use of Energy University of Stuttgart, November 2005.
- [13] Meibom P, Larsen HV, Barth R, Brand H, Weber C, Voll O, "Wilmar, Deliverable D6.2 (b) - Wilmar Joint Market Model Documentation," Risø-R-1552(EN), Roskilde, Denmark, January 2006.
- [14] Hansen AB, Orths A, Falk K, Detlefsen NK, "Danish Fossil Independent Energy System 2050- From Strategic Investigations to Intra-Hour Simulation of Balancing Issues," in 10th International Workshop on Large-Scale Integration of Wind Power into Power Systems, Aarhus, 2011.
- [15] "Operation Handbook, P1-Policy 1: Load-Frequency Control and Performance," ENTSOE-E, March, 2010.
- [16] Skødt T, "Electricity interconnections," *Energinet.dk*, 20 February 2014. [Online]. Available: <https://www.energinet.dk/EN/ANLAEG-OG-PROJEKTER/Generelt-om-elanlaeg/Sider/Elforbindelser-til-udlandet.aspx>.
- [17] I.C. Report, "Dynamic Models for Steam and Hydro Turbines in Power System Studies," *IEEE Transactions on Power Apparatus and Systems*, Vols. PAS-92, no. 6, pp. 1904-1915, November 1973.
- [18] CIGRE Task Force 25 of Advisory Group 02 of Study Committee C4, "Modeling of Gas Turbines and Steam Turbines in Combined Cycle Power Plants," CIGRE, 2003.
- [19] IEC 61400-27 Committee Draft, Wind Turbines Part 27-1, "Electrical simulation models for wind power generation Wind turbines," IEC Std. committee Draft (CD) 88/424/CD, 2012.

Author Biographies

Abdul Basit received the B.Sc. degree in electrical engineering from the University of Engineering & Technology, Peshawar, Pakistan in 2006 and M.Sc. degree in electrical power engineering from Chalmers University of Technology, Sweden in 2011.

He is currently employed as a PhD student at Department of Wind Energy of the Technical University of Denmark (DTU). His research interest includes integration of wind power into power systems, automatic generation control, wind power plant control, and power systems.

Anca D. Hansen received the degree in aerospace engineering from the Technical University of Bucharest, Romania, in 1992 and a Ph.D. degree in modelling and control engineering from Denmark Technical University in 1996. In 1998, she joined Risø National Laboratory, working first as PostDoc and then a scientist with modelling and control of wind turbines. Today, she is working as Senior Scientist in the DTU Wind Energy department, former Risø National Laboratory, in Denmark. Her research interest is integration of wind power into power systems, involving different technical topics on dynamic modelling and control of wind power plants, ancillary services as well as power system control and stability topics. She is author or co-author of more than 100 journal/conference papers, several research reports in her research fields.

Mufit Altin received B.Sc. and M.Sc. degrees in electrical and electronics engineering from the Middle East Technical University (METU), Ankara in 2004 and 2009, respectively. He obtained his PhD degree from the Department of Energy Technology, Aalborg University, Denmark, in 2012, where he was employed as a researcher under the Vestas Power Programme during his PhD. He joined and is currently working as a postdoc at Department of Wind Energy of the Technical University of Denmark (DTU). His research interest includes distribution automation, wind power plant control, wind energy, and power systems.

Poul E. Sørensen was born in 1958. He received the M.Sc. degree in electrical engineering from the Technical University of Denmark, Copenhagen, Denmark, in 1987. Since 1987, he has been at Risø National Laboratory, Roskilde, where he is currently a Professor. His research interests include integration of wind power into power systems, involving a variety of technical disciplines including power system control and stability, dynamic modeling and control of wind turbines and wind farms, and wind fluctuation statistics. Prof. Sørensen is convener of the IEC 61400-27 working group.

Mette Gamst received B.Sc. and M.Sc. degrees in computer science from the University of Copenhagen, Denmark in 2004 and 2007, respectively. She obtained her PhD degree from the DTU Management Engineering, Technical University of Denmark in 2010. She is currently working as system analyst in Energinet.dk.

P 3: Basit A.; Hansen A. D.; Altin M.; Sørensen P.; Giannopoulos G, "Real-time impact of power balancing on power system operation with large scale integration of wind power" Submitted to Journal of modern power system and clean energy

Real-time impact of power balancing on power system operation with large scale integration of wind power

A. Basit^{1,*§}, A.D. Hansen*, P. Sørensen* and G. Giannopoulos[‡]

* Technical University of Denmark, Department of Wind Energy, Frederiksborgvej 399, Building 125, 4000 Roskilde, Denmark

§ Sino-Danish Centre for Education and Research, Niels Jensens Vej 2, 8000 Aarhus, Denmark

‡ ELIA SYSTEM OPERATOR, Keizerslaan 20, 1000 Brussels, Belgium

Abstract – Highly wind power integrated power system requires continuous active power regulation to tackle the power imbalances resulting from the wind power forecast errors. The active power balance is maintained in real-time with the automatic generation control and also from the control room, where regulating power bids are activated manually. In this article, an algorithm is developed to simulate the activation of regulating power bids, as performed in the control room, during power imbalance between generation and load demand. In addition, the active power balance is also controlled through automatic generation control, where coordinated control strategy between combined heat and power plants and wind power plant enhances the secure power system operation. The developed algorithm emulating the control room response, to deal with real-time power imbalance, is applied and investigated on the future Danish power system model. The power system model takes the hour-ahead regulating power plan from power balancing model and the generation and power exchange capacities for the year 2020 into account. The real-time impact of power balancing in a highly wind power integrated power system is assessed and discussed by means of simulations for different possible scenarios.

1 Introduction

Increasing wind power integration influences the technical operation of a power system, particularly the active power balance control between generation and demand. The variable wind power generation together with the technical capabilities of the generating units and the market rules might hinder the power system balance control. These factors must be taken into account while planning the power balancing operation of a large scale wind power integrated power system.

The Transmission System Operators (TSOs) have to securely operate the power system in transporting the generated electricity to the end consumers. In deregulated power systems, the electricity is traded in electricity markets by the balance responsible companies that can produce, consume or retail. Examples of electricity markets are the Day-ahead (DA), intraday and regulating power markets [1]. The balance responsible trades in DA market and balance the power system for each operating period in the next day. If the power system comes out of balance on an operating day, owing to the update of wind power forecasts or the unavailability of power plants, the balance responsible trades again in intraday market for every operating period to one hour in advance of the actual operation hour. The intraday market balances the power system. However wind power forecast errors and other non-contingent events might create power imbalance within the actual operating hour. These imbalances are then minimized by activating the power bids, within minutes, from regulating power market. The TSOs select the dispatch bids with the foremost intent of preserving system integrity with minimum production cost.

¹ Corresponding author: Tel.: +45 2492 1623; Fax: +45 4677 5083; E-mail address: abdl@dtu.dk (A. Basit)

With increasing large scale integration wind power, active power balancing is becoming a challenging technical issue. Several studies have been performed in this area over the last few years. For example, according to [2], the increasing integration of wind power alters the frequency behaviour and solutions must be developed to meet these challenges. A Dutch case study in [3] shows that additional regulating reserves are required in the presence of large scale wind power. The Chinese studies in [4] have led to the conclusion that the fluctuation from WPPs can be controlled via conventional generators. According to [5], the WPPs can participate in frequency regulation services with energy storage devices such as super capacitor banks, while [6] examines the benefits of active power regulation from WPPs. However to enhance the operational security of the power system, further studies on the system level is the need of the hour.

Real-time control of the regulating power is necessary for reliable and secure operation of future power system with large scale wind power integration. The objective of this article is to study how active power balance can be controlled in real-time with coordinated automatic generation control (AGC) action between Combined Heat and Power Plants (CHPs) and Wind Power Plant (WPPs) and by activating the regulating power bids, as performed in the control room. For this purpose, an algorithm named as '*rolling balance*' has been developed for this study which emulates the real-time control room response while activating the regulating bids.

To study the real-time active power balance control in a power system with high wind power penetration level, the *rolling balance* is exemplified on the future Danish power system corresponding to year 2020, where 50% of the total electricity production has to be supplied by wind power [7]. The balanced regulating power plan, in a five minute resolution, for generation and power exchange with neighbouring power systems is provided by hour-ahead (HA) power balancing program. However, wind power forecast errors and other events might cause a power imbalance in the real time, which can be partially compensated by activating the additional regulating power with a *rolling balance* and the coordinated AGC response. The *rolling balance* activates the regulating power from CHPs, to minimize the real time power imbalance in the power system.

The article is organised as follows. First the dynamic power system model is described. The active power balancing models and the proposed algorithm '*rolling balance*' are then presented and explained. The performance of the *rolling balance* and the AGC is then assessed through simulations for the year 2020 with high wind penetration scenarios and the conclusive remarks are reported at the end.

2 *Dynamic power system model*

As aforementioned, the Danish power system is used to validate the performance of the *rolling balance* and the AGC. The Danish power system is composed of Eastern and Western Danish power systems, which are synchronously connected to the Nordic and Continental European (CE) synchronous power systems, respectively [8]. To study the active power balance control in the Danish power system, it requires a detailed dynamic representation of the power system that includes conventional power plants, WPPs and interconnection with neighbouring power systems. The system interconnections and the aggregated power plants models, developed in Power Factory, are explained below.

2.1 **System interconnection**

As depicted in Figure 1, the Eastern and Western Danish power systems are connected through an HVDC connection, i.e. Great Belt Link (GBL) having a transmission capacity of 600 MW. The Danish power systems are also connected to the strong neighbouring power systems of Nordic and CE, which are offering large frequency bias factor [9]. The Eastern Danish power system is synchronized with the Nordic power system through Sweden, whereas the Western Danish power system is synchronized via Germany with the CE power system. Figure 1 shows the interconnection capacities of the Danish power system with its neighbouring powers planned for the year 2020 [10]. The AC interconnection is shown as a solid line and the DC interconnection with solid line and diode symbol. In this study, the system interconnections are modelled as load where the export power can be seen as positive load and the import power as negative load. Moreover, an external grid based on the recommendation for CE and Nordic power systems is modelled to study the dynamics on AC interconnections [11] & [12].

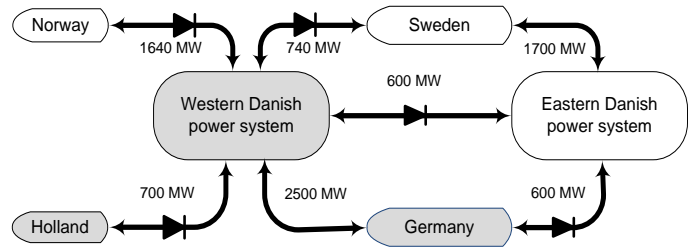

Figure 1: Danish power system interconnections

2.2 Power plants modelling

The electrical power generation in Denmark is a combination of conventional and renewable generation sources. The conventional power generation is typically from CHPs and De-centralised Combined Heat and Power Plants (DCHPs), while renewable generation is primary based on WPPs contribution. In this study, aggregated models for conventional power plants and WPPs are implemented, as they have the advantage of reduced computation effort, while still containing dynamic features relevant for long term dynamic simulation studies. These aggregated models are developed based on description found in [8] & [13, 14, 15, 16] and takes the information from HA power balancing model, *rolling balance* and the AGC for power generation set points.

a) Combined heat and power plant model (CHP)

An aggregated CHP model is developed based on studies in [13] & [14], to examine the dynamic features of a power plant in long term dynamic simulation studies, which may affect the system stability due to its slow boiler response. The response time and ramp rates associated with CHP are in order of minutes and are the dominant characteristic for power system studies.

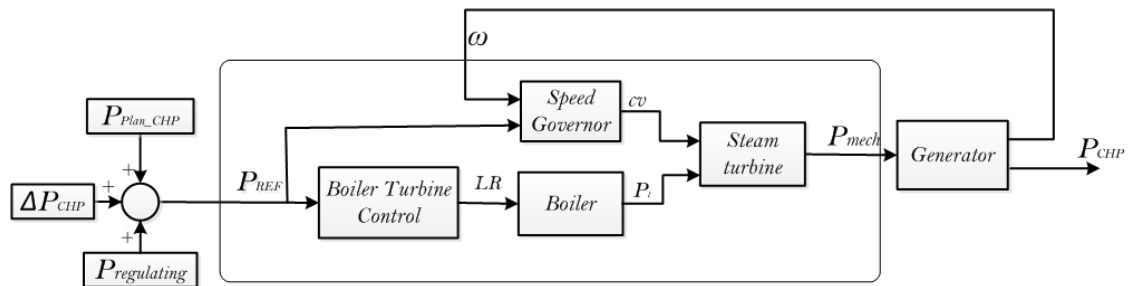

Figure 2: Aggregated CHP model

A generic diagram of an aggregated CHP model consisting of a thermal boiler, a boiler turbine controller, a steam turbine and a speed governor, is illustrated in Figure 2. The boiler model takes into

account the practical limits of the turbine output and the delays associated with the stored steam energy, while the steam turbine introduces the delays associated with the valve movement and change in the steam flow. The primary response capability is reflected through the speed governor action, which modifies the valve position of the steam turbine, according to its droop characteristic.

b) Decentralized combined heat and power plant (DCHP)

An aggregated generic model for DCHP power plant is developed for long term dynamic simulation studies based on the study in [15]. The model contains a speed governor and a gas turbine, as shown in Figure 3. The droop characteristics of the speed governor govern the primary response.

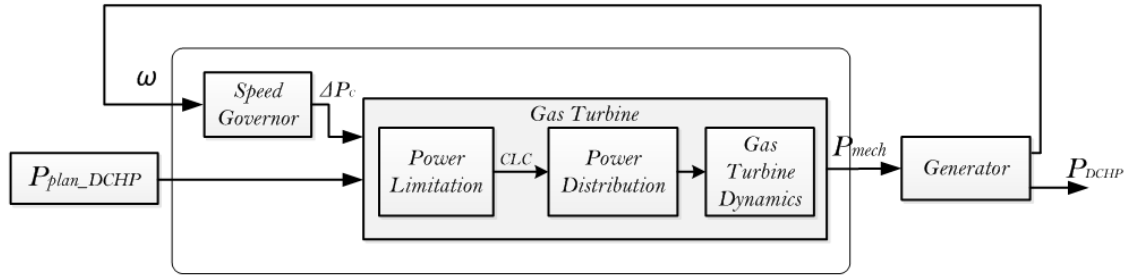

Figure 3: Aggregated DCHP model

In the gas turbine model, the power limitation block provides the physical restriction on turbine response and the excessive firing during ramping. The power distribution block represents the physical characteristics of fuel flow, air flow and allowable temperature. While, gas turbine dynamics block is included to represent the physical dynamics of combustion chambers and air compressor.

c) Wind power plant (WPP)

At the power system level, the aggregate performance of a large number of wind turbines is more important than the details of an individual wind turbine. In this study, a simplified aggregated WPP model is developed for long term dynamic simulation studies based on the IEC61400-27-1 recommendations [16], and further simplified for the secondary active power control purpose, for each part of the Danish power system.

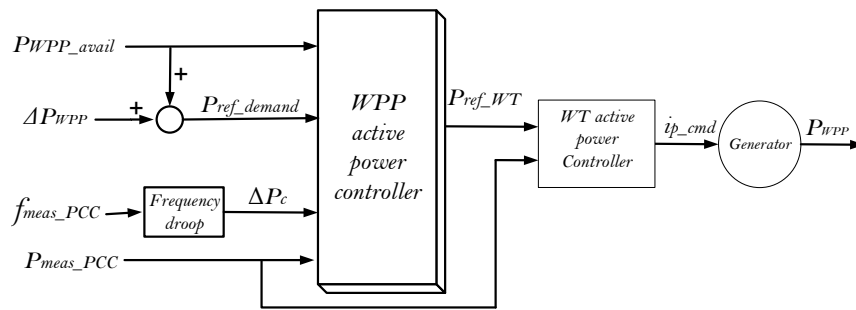

Figure 4: Aggregated WPP model

The aggregated WPP model, shown in Figure 4, has a hierarchy structure, namely that there is WPP active power control level and a wind turbine (WT) active power control level. The power reference P_{ref_WT} to the WT active power controller is generated by the WPP active power controller, based on the primary response signal (ΔP_c), the reference power signal (P_{ref_demand}) from the power balancing model and the measured power in the Point of Common Connection (PCC). The P_{ref_demand} depends on the required secondary response (ΔP_{WPP}) from the AGC and the available wind power signal (P_{WPP_avail}) from the power balancing model. The control both in the WT and in the WPP level is realised by using PI

controllers, for example, the PI controller in the WPP active power controller reduces the error between measured power at PCC (P_{meas_PCC}) and the sum between the reference power and the primary response signal (P_{ref_demand} & ΔP_c), in the decision of the P_{ref_WT} . Based on P_{ref_WT} and P_{meas_PCC} , the WT controller and generator simulates the relevant dynamic response of the WPP.

3 Power system operation

The TSOs have to maintain the active power in balance in any operating condition. They utilize and combine information from different simulation programs to ensure the power balance in power system. These programs provide information regarding wind power forecast, load demand and also simulates the regulating power plan for balanced power system. Simulation power Balancing (SimBa) is such kind of power balancing program that is used to simulate HA regulating power plan for the Danish power system [17].

As illustrated in Figure 5, SimBa uses inputs from DA market model and wind power forecast model, i.e. Wind Power Integration in Liberalised Electricity Markets (WILMAR) and Correlated Wind power fluctuations (CorWind) respectively [17]. The WILMAR provides hourly values for energy production, load and the power exchange between interconnected areas (P_{plan_DA}), while CorWind provides the DA (P_{WPP_DA}) and HA (P_{WPP_HA}) forecasts of wind power and the available wind power (P_{WPP_avail}). SimBa estimates the possible wind power schedule within the operating hour based on P_{WPP_HA} and balances the power system internally, while taking the current grid regulations and the energy market rules continuously into account. SimBa creates a list of regulating bids based on the marginal cost function, bidding price and production capacity for each unit and provides the five minute resolution plan (P_{plan_HA}) for generating units and power exchange with neighbouring power systems. It is worth mentioning that SimBa while activating the bids also takes the ramping of generating units (i.e. 30 MW/min considered in this study) and the power exchange into account. The Nordic and CE power systems ramps the agreed power exchange in 30 and 10 minutes, respectively. The power exchange starts 5 minutes and 15 minutes before the agreed exchange hour in CE power system and in the Nordic power system, respectively [18].

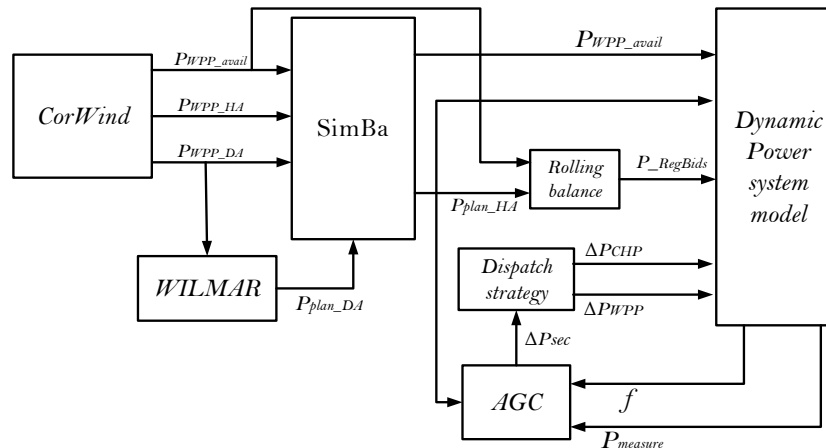

Figure 5: Overview of the signals between CorWind, WILMAR, SimBa, dynamic power system model, rolling balance, AGC and the dispatch strategy

In this study, power mismatch between generation and load appears from the HA balanced power system, if the actual wind power generated within the operating hour differs from the forecast. In order

to maintain the balance power system operation within the operating hour, the speed governors instantly provides the primary response and then the AGC along with *rolling balance* compensates the power imbalance.

3.1 Automatic Generation Control (AGC)

AGC is used to routinely balance the power system and makes its operation more reliable [18]. Traditionally conventional power plants provide the secondary frequency control in real time operation. However, the increasing wind power integration may require active participation from WPPs in secondary frequency control in future power systems along with conventional power plants, as some conventional power plants might be replaced by WPPs. Coordinated AGC with dispatch between conventional power plants and WPPs is therefore of high priority for operational security and stability.

The AGC, developed and implemented in this study, is sketched in Figure 6. The “area control error” (P_{ACE}) calculation is based on the power exchange deviation from its scheduled (ΔP) and the frequency deviation (Δf) from its nominal value, as shown in equation 1 and equation 2. The frequency bias setting ‘B’ of the AGC, in equation 1, depends on overall droop characteristics of the generating units taking part in the primary response.

$$P_{ACE} = \Delta P + (\Delta f \times B) \quad (1)$$

$$\Delta P = P_{exchange} - P_{exchange_HA} \quad (2)$$

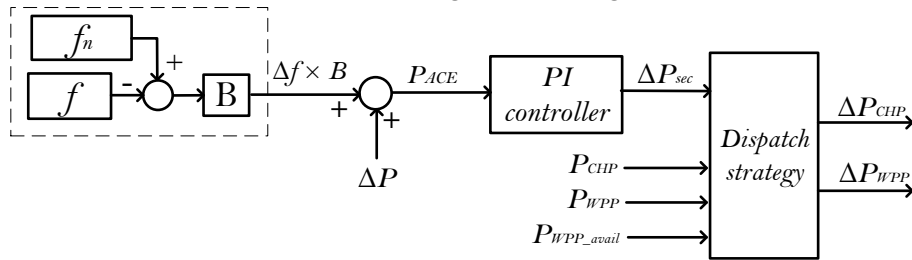

Figure 6: AGC model

The central controller, usually a proportional integral (PI), process the P_{ACE} and calculates the required change in production (ΔP_{sec}). The change in production, based on the below equation, is then distributed through ‘dispatch strategy’ block among the participating generators, i.e. CHP and WPP in this study.

$$\Delta P_{set} = -K \times P_{ACE} - \frac{1}{T} \int P_{ACE} \quad (3)$$

Unlike the traditional AGC, the coordinated dispatch between CHP and WPP is performed in this study. The dispatch is based on the assumption that the wind power is down regulated only when CHPs are unable to down regulate their production in case of generation excess, e.g. CHPs are operating on their lower generation level (20% of the online capacity) or AGC dispatch for the CHPs (ΔP_{CHP}) touches the minimum limit. Otherwise, the WPPs will generate the available wind power and only CHPs will participate in up regulation process. The ΔP_{CHP} is limited to ± 90 MW within the dispatch strategy block, as it is the case for the AGC acting on the border of Western Denmark with Germany. The WPPs will follow the AGC command to safe guard secure power system operation and if necessary will down regulate its production to the minimum operating point.

3.2 Rolling balance control

Rolling balance is designed to simulate the actions similar to the control room, to activate the regulating power bids ($P_{RegBids}$) within the real-time for balanced power system operation. The real time

power imbalance in the Eastern and Western Danish power systems is shown in Figure 7. Equation 4 calculates the power imbalance in this study, taking into account the HA schedule for conventional generation and power exchange (import and export power), available wind power generation and load demand, which is assumed to be equal to the HA forecast. However in real engineering, the control operator can estimate the load demand with very short term load forecasting technique [19] and system data from the SCADA/EMS. The operator after obtaining system data calculates the former forecasting error and then precisely estimates the load demand from the predicted load in a five minute resolution. The estimated load demand can then be used for calculating the power imbalance.

$$P_{\text{imbalance}} = P_{\text{conventional_HA}} + P_{\text{Imports_HA}} - P_{\text{Exports_HA}} + P_{\text{WPP_avail}} - P_{\text{Load}} \quad (4)$$

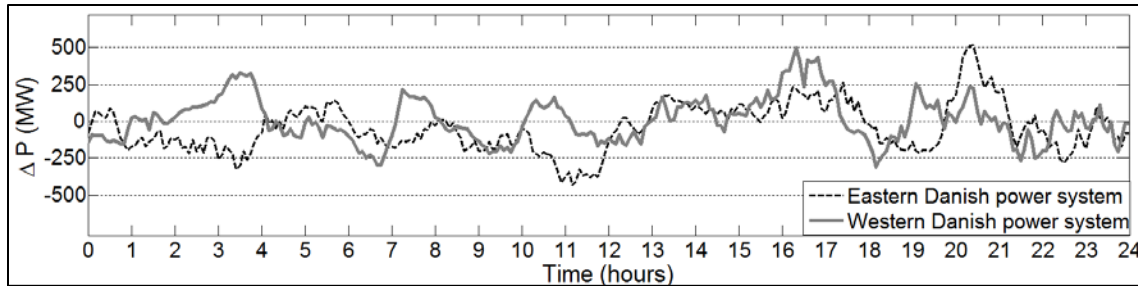

Figure 7: Power imbalance in Danish power system

The power imbalance is either caused due to forecast error (wind power/load) or other non-contingent events. In this study, the reason for power imbalance is the wind power forecast error, as illustrated in Figure 8 by comparing the power imbalance with HA wind power forecast error. The HA wind power forecast is calculated as:

$$P_{\text{HA_error}}^{\text{WPP}} = P_{\text{WPP_avail}} - P_{\text{WPP_HA}} \quad (5)$$

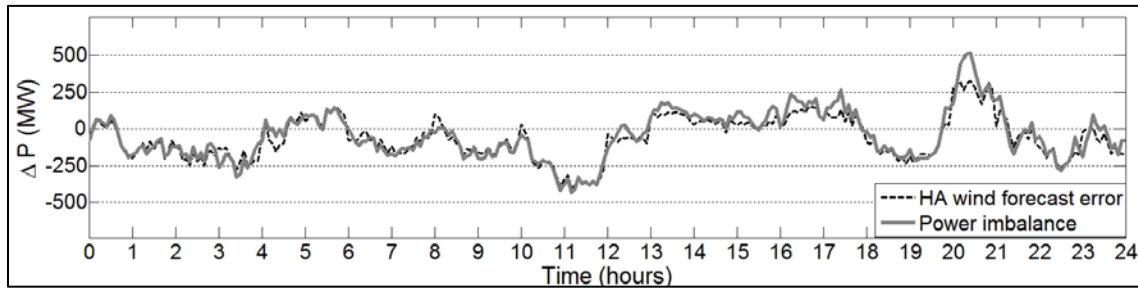

Figure 8: Power imbalance and HA wind forecast error

The *rolling balance* uses the power imbalance as an input time series and will activate the regulating bids to alleviate the imbalances as effectively as possible. Before activating the regulating bids it has to ensure that the imbalance is greater than the threshold level and persistent as well, so that the algorithm does not react excessively. In this study, if the power imbalance is greater than the 30 MW and persists for 15 minutes (i.e. three 5 minutes period), the *rolling balance* will activate the regulating bid equal to the minimum of the power imbalance in the start of third period, i.e. after the AGC response. The following rule is applied in activating the regulating bid:

$$\begin{aligned} & \text{if, } \Delta p(i) > \varepsilon \ \& \ \Delta p(i-1) > \varepsilon \ \& \ \Delta p(i-2) > \varepsilon \\ & \quad \Rightarrow \text{activate bids equal to } \min(\Delta p(i), \Delta p(i-1), \Delta p(i-2)) \\ & \text{else, } \Delta p(i) < -\varepsilon \ \& \ \Delta p(i-1) < -\varepsilon \ \& \ \Delta p(i-2) < -\varepsilon \\ & \quad \Rightarrow \text{activate bids equal to } \max(\Delta p(i), \Delta p(i-1), \Delta p(i-2)) \end{aligned}$$

where ϵ is the threshold level and $\Delta p(i)$ is the power imbalance at time period 'i'. If the imbalance in the first group of points met the aforementioned criteria, the regulating bid equal to the smallest power imbalance of the three consecutive points is activated with a ramp rate of 30 MW/min and the new points are checked. If the second group of points is also found to meet the criteria, then again the regulating bid is activated. But if one of these points does not meet the criteria, then the regulating bid is not activated. Figure 9 shows the regulating power activated in Eastern and Western Danish power systems by the *rolling balance* algorithm for an imbalance shown in Figure 7.

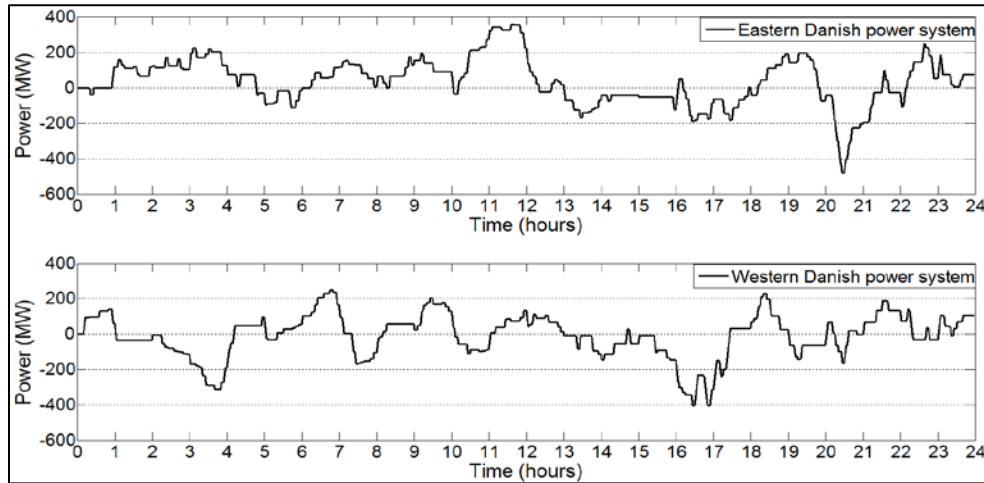

Figure 9: Regulating power activated in Eastern & Western Danish power systems

The coordination between aforementioned power balance control schemes is demonstrated in Figure 10, where primary response, AGC response and *rolling balance* are timely disassociated. Following the power imbalance, the power plants equipped with the speed governors provides the initial support by releasing the primary reserves within 30 seconds. Afterwards, the AGC provides the secondary control by ramping the power generation from the participating power plants. The response of the AGC depends on the time delays associated with the AGC system, CHP and WPP. In this study, the secondary response is provided within 7 – 8 minutes. The *rolling balance* activates the regulating power at the start of third period (10th minute), if the power imbalance is persistent for three periods and greater than threshold level. The activation of regulating power through *rolling balance* will also restores the secondary reserves, depending on the remaining power imbalance.

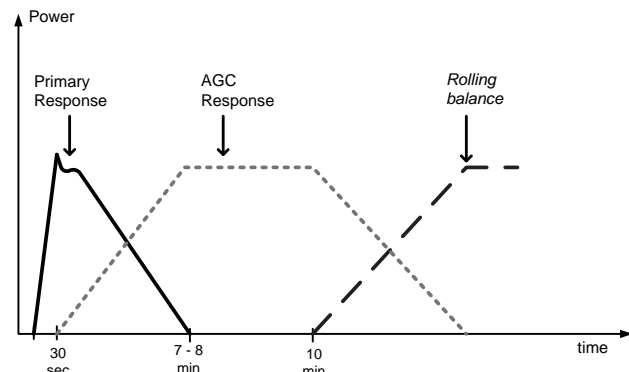

Figure 10: Proposed real-time balance control

The real-time power balancing concept provided above activates the regulating power while taking in account the maximum and minimum limits on generating units, dispatch limits and the generation cost. However, to implement the above concept, in addition to the above constraints, the coordinated AGC and *rolling balance* must also take the transmission constraints in account.

4 Simulations and Results

A set of simulations has been carried out to illustrate the performance of the power system model on the focus of active power balanced control. The simulations are performed using the time series for generation, load and power exchange generated by HA power balancing model (SimBa) for the Danish power system and are the assumptions for the year 2020 based on the real data from the year 2009. The conventional generation and the power exchange are using HA time series, while WPP generates the available wind power. Power imbalance appears within the operating hour, if HA wind power forecast is not the same as available wind power. This imbalance is compensated by AGC and by activating the regulating bids from CHPs within the operating hour by an algorithm (*rolling balance*), developed for this study.

The motivation to investigate the system behaviour on the considered day is the availability of wind power and high load demand in a large scale wind power integrated power system. The availability of wind allows the WPPs to generate more power than conventional power plants and also positive power exports with neighbouring power systems. The power exports are calculated by subtracting the total export power from total import power with neighbouring power systems. On the specific day in Eastern Denmark, the conventional power plants generated 33.31 GWh of electricity, while WPPs generated 43.2 GWh, i.e. 56.46% of the total electricity production. The high production from WPPs allows the power exports of 32.75 GWh from Eastern Danish power system, when the load demand was 43.75 GWh. Similarly in Western Denmark, 45.77 GWh is generated from conventional power plants and 59.53 GWh from WPP, i.e. 56.53%. While, the total load demand and the power exports are 63.98 GWh and 41.27 GWh, respectively. It can also be noted that on specific day, WPP contributed 98.7% and 93% of the total load demand in Eastern and Western Danish power system, respectively.

As aforementioned, the HA wind forecast error will create an imbalance between generation and load demand within the operating hour, thus deviating the system frequency from its nominal level. In response, the speed governors instantaneously release the primary reserves and balance the system frequency at new level. The deviation in frequency from its nominal level will also diverge the power exchange with from its schedule. To return the system frequency to its nominal level and power exchange to its schedule, the AGC provides the secondary response. The AGC responds to the area control error (P_{ACE}) with ΔP_{sec} and then distribute it among the participating generators through secondary dispatch block. The ΔP_{sec} lags behind ΔP_{ACE} , due to the delays in AGC system and the delays associated with the power plants response which does not allow the units to change their output as ΔP_{ACE} . These delays are due to the ramp in the reference power and also due to the slow boiler response of CHP units, as boiler needs 5 – 6 minutes to modify its output pressure when demanded.

The secondary dispatch provides new set points to the CHP and WPP, based on the operating conditions of CHP and WPP and also on the available wind power. The secondary dispatch to the CHP (ΔP_{CHP}) and WPP (ΔP_{WPP}) is shown in Figure 11, where the WPPs only participate in the down regulating process, while CHPs contributes in both up and down regulating processes. The ΔP_{CHP} is limited by ± 90 MW, as the case of AGC in Western Danish power system. The down regulating secondary dispatch to the WPPs is activated only when CHPs are unable to provide the required response, i.e. the ΔP_{CHP} reaches -90MW or they are operating at their lower limit (20% of the online capacity). The AGC controlled WPP then reduces the real time power imbalance in the Danish power system by down

regulating its production. Notice that the ΔP_{WPP} is seldom activated, only when CHP are not able to down regulate their production.

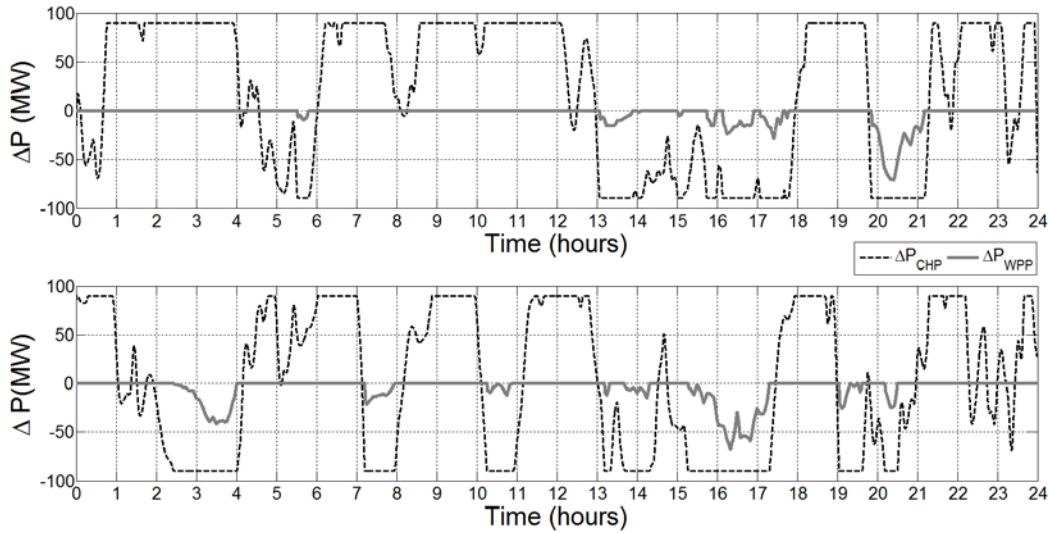

Figure 11: Secondary dispatch – Eastern Danish power system (top) & Western Danish power system (bottom)

In order to reduce the real time power imbalance and restores the secondary reserves, the *rolling balance* activates the regulating bids where the process is almost similar to the control room operator’s response. The *rolling balance* activates the bids if the imbalance is greater than threshold level (30 MW considered for this study) and persists for three periods, i.e. 15 minutes. The regulating bid is activated at the start of third period and equals to the minimum imbalance of three consecutive periods, while the AGC directly responds to the power imbalance. The regulating power activated by the *rolling balance* is already shown in Figure 9. The resulting AGC dispatch after the activation of regulating power is shown in Figure 12 and it can be noticed that the rolling balance restores some of the secondary reserves and thereby reduces the regulating burden on AGC.

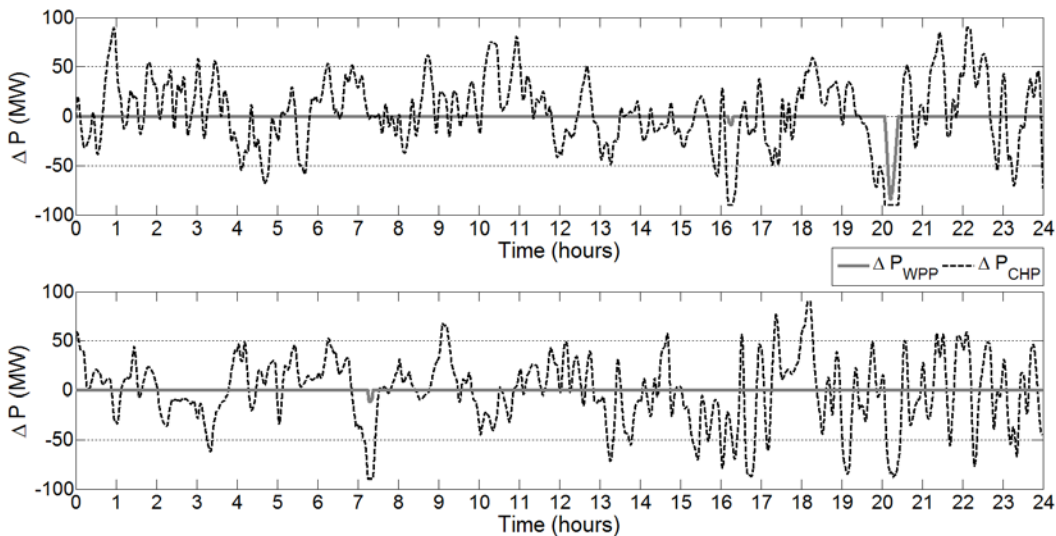

Figure 12: Secondary dispatch with rolling balance– Eastern Danish power system (top) & Western Danish power system (bottom)

Activating the regulating bids through *rolling balance* not only reduces the real time active power imbalance but makes the power system operation more reliable and secure. Figure 13 compares the power imbalance in the Danish power system, when:

- (A) – Real-time control is provided with coordinated AGC and *rolling balance*
- (B) – Real-time control is provided with coordinated AGC
- (C) – Real-time control is provided with conventional AGC, when only CHP provides support

It can be noticed that the power imbalance has decreased substantially with the proposed active power balance technique, i.e. when real-time control is provided with coordinated AGC and *rolling balance*. The conventional AGC also reduces the power imbalance in real-time, but the programmed activation of regulating bids and coordinated AGC assures the reliable operation of highly wind power integrated power system.

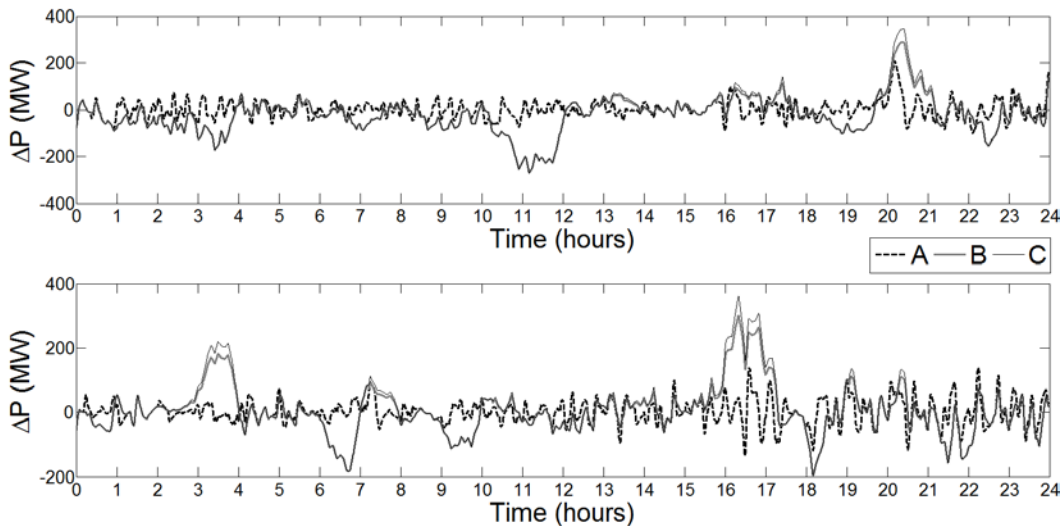

Figure 13: Power imbalance – Eastern Danish power system (top) & Western Danish power system (bottom)

5 Conclusion

Regulating power in a deregulated power system is always needed to increase system reliability and to ensure power supply security. The need for regulating reserves is growing with the increase of wind power integration in power systems. Beside this, effective way of bids activation is also of high importance. In this article, an algorithm has been designed in order to simulate the actions similar to the control room with respect to real time active power balance control. The algorithm '*rolling balance*' is exemplified and implemented for the case of a power system that reflects the dynamics of the future Danish power system with a high wind penetration scenario. The dynamic model of a power system uses input time series from an hour-ahead power balancing model (SimBa) for power generation, load demand and power exchange corresponding to one particular day with high wind speed and high load demand.

The studies performed and presented in this article illustrate how power imbalances between load and generation, caused by wind power forecast error can be compensated effectively by the automatic activation of regulating power bids from conventional power plants and also by regulating the active power production from combined heat and power plants and wind power plants. The *rolling balance* is designed to activate the regulating bids while the coordinated automatic generation control

provides the required secondary response from combined heat and power plants and wind power plants.

The importance of the regulating bids and of their effective activation for a reliable and secure operation of large wind power integrated power system has been demonstrated through the present investigation. The activation of the regulating reserves through the *rolling balance* efficiently reduces the real time imbalances and thereby ensuring reliable power system operation. Furthermore the wind power plant integrated coordinated automatic generation control ensures the secure power system operation. However, better forecasting of wind speed and the load demand is still desirable for operational security of highly wind power integrated power system.

Acknowledgement

This paper is a part of PhD project funded by Sino-Danish centre for education and research (SDC).

References

- [1] Sørensen P., Norheim I., Meibom P., Uhlen K., "Simulations of wind power integration with complementary power system planning tools," *Electric Power Systems Research*, vol. 78, no. 6, pp. 1069-1079, June 2008.
- [2] Doherty R., Mullane A., Nolan G., Burke D.J., "An assessment of the impact of wind generation on system frequency control," *IEEE Trans. on Power Systems*, vol. 25, no. 1, pp. 452 - 460, 2010.
- [3] Ummels B.C., Gibescu M., Kling W.L. and Paap G.C., "Performance of Automatic Generation Control Mechanisms with Large-Scale Wind Power," in *Nordic Wind Power Conference*, 2007.
- [4] BiHui L., Hong S., Yong T., Hongyun Z., Feng S., and Dongfu L., "Study on the frequency control method and AGC model of wind power integration based on the full dynamic process simulation program," in *International Conference on Power System Automation and Protection (APAP)*, IEEE, Beijing, 2011.
- [5] Antonishen M.P., Hai H.Y., Brekken T.K.A., Jouanne A.V., Yokochi A., Halamay D.A., Jiajia S., Naviaux D.B., Davidson J.D. and Bistrika A., "A methodology to enable wind farm participation in automatic generation control using energy storage devices," in *Power and Energy Society General Meeting*, IEEE, San Diego, CA, 2012.
- [6] Zhu J. and Cheung K., "Analysis of regulating wind power for power systems," in *Power & Energy Society General Meeting*, IEEE, Calgary, AB, 26-30 July 2009.
- [7] Vittrup C., "2013 was a record-setting year for Danish wind power," *Energinet.dk*, 15 January 2014. [Online]. Available: <http://energinet.dk/EN/El/Nyheder/Sider/2013-var-et-rekordaar-for-dansk-vindkraft.aspx>. [Accessed 06 February 2014].
- [8] Basit A., Hansen A.D., Sorensen P., "Dynamic model of frequency control in Danish power system with large scale integration of wind power," in *China Wind Power Conference*, Beijing, 2013.
- [9] Rebours Y.G., Kirschen D.S., Trotignon M. and Rossignol S., "A Survey of Frequency and Voltage Control Ancillary Services—Part I: Technical Features," *IEEE TRANSACTIONS ON POWER SYSTEMS*, vol. 22, no. 1, pp. 350 - 357, FEBRUARY 2007.
- [10] Energinet.dk, "Electricity interconnections," *Energinet.dk*, 10 April 2012. [Online]. Available: www.energinet.dk/EN/ANLAEG-OG-PROJEKTER/Generelt-om-elanlaeg/Sider/Elforbindelser-til-udlandet.aspx. [Accessed September 2013].
- [11] UCTE, "Policy 1: Load-Frequency Control," *ENTSO-E*, 2009.

- [12] Norheim I, Lindgren E, Uski S, Sorensen P, Jauch C , “WILMAR WP5-Deliverable D5.1, System Stability Analysis,” SINTEF, 2005.
- [13] IEEE Committee Report, “Dynamic models for fossil fueled steam units in power system studies,” IEEE Transaction on Power Systems, vol. 6, no. 2, pp. 753-761, May 1991.
- [14] Byerly R., “Dynamic models for steam and hydro turbines in power system studies,” IEEE Transactions on Power Apparatus and Systems, pp. 1904-1915, 1973.
- [15] CIGRE Task Force 25 of Advisory Group 02 of Study Committee C4, “Modeling of Gas Turbines and Steam Turbines in Combined Cycle Power Plants,” CIGRE, 2003.
- [16] IEC 61400-27 Committee Draft, Wind Turbines Part 27-1, “Electrical simulation models for wind power generation Wind turbines,” IEC Std. committee Draft (CD) 88/424/CD, 2012.
- [17] Giannopoulos G., Frequency control in area with large scale wind power, Roskilde: Denmark Technical University, 2012.
- [18] ENTSO-E, “Continental Europe Operation Handbook – p1: LOAD-FREQUENCY CONTROL AND PERFORMANCE,” [Online]. Available: <https://www.entsoe.eu/publications/system-operations-reports/operation-handbook/>. [Accessed September 2013].
- [19] Liu K., Subbarayan S., Shoults R.R., Manry M.T., Kwan C., Lewis F.L., Naccarino J., “Comparison of very short-term load forecasting techniques,” IEEE Transactions Power Systems, vol. 11, pp. 887,882, 1996.

P4: Basit A.; Hansen A. D.; Altin M.; Sørensen P.: "Analysis of Highly Wind Power Integrated Power System model performance during Critical Weather conditions", Wind Integration Workshop (WIW), Berlin, 2014

Analysis of Highly Wind Power Integrated Power System model performance during Critical Weather conditions

Abdul Basit
DTU wind energy
Technical University of Denmark
Denmark
Sino-Danish Centre for Education and Research (SDC)
Denmark

Anca D. Hansen
Poul E. Sørensen
Mufit Altin
DTU wind energy
Technical University of Denmark
Denmark

Abstract – Secure power system operation of a highly wind power integrated power system is always at risk during critical weather conditions, e.g. in extreme high winds. The risk is even higher when 50% of the total electricity consumption has to be supplied by wind power, as the case for the future Danish power system in 2020. This paper analyses and compares the performance of the future Danish power system during extreme wind speeds, where wind power plants are either controlled through a traditional High Wind Shut Down storm controller or a new High Wind Extended Production storm controller. For this purpose, the power system model has been developed that represents the relevant dynamic features of power plants and compensates for power imbalances caused by the forecasting error during critical weather conditions. The regulating power plan, as an input time series for the developed power system model, is provided by the hour-ahead power balancing model, i.e. Simulation power Balancing model (SimBa). The regulating power plan is prepared from day-ahead power production plan and hour-ahead wind power forecast. The wind power (forecasts and available) are provided by the Correlated Wind power fluctuations (CorWind) model, where the wind turbine storm controllers are also implemented.

Keywords – Wind Power Plants (WPPs); Automatic Generation Control (AGC); Power balance control; High Wind Shut Down (HWSD); High Wind Extended Production (HWEP)

I. Introduction

High wind power integration influences the technical operation of a power system, particularly the active power balance control between generation and demand during extreme high wind speeds. It can result in a significant loss of wind power in very short time (minutes) [1], instigating the power imbalance in the power system. With increasing wind power integration, the situation is even more alarming for future power system, e.g. the case of Danish power system in 2020, where 50% of the total electricity production has to be supplied by wind power [2]. Therefore, while planning the power balancing operation of a large scale wind power integrated power system; the variable wind power generation must be taken in account along with the technical capabilities of the generating units.

The wind turbine is normally equipped with High Wind Shut Down (HWSD) storm controller to safeguard turbine from mechanical breakdown during extreme winds. The HWSD controller halts wind turbines from operation if wind speed increases than 25 m/s [3]. However in similar circumstances, the wind turbine equipped with the new High Wind Extended Production (HWEP) storm controller will gradually reduce their power output [3], providing a positive impact on the power system balance without effecting the turbines structural integrity. This study analyses the impact of HWSD or HWEP storm controller on active power balance control in future Western Danish power system model.

The Western Danish power system model with high wind power penetration is developed in this study, taking the generation and power exchange capacities for the year 2020 into account [4]. The implemented power system model includes models for the centralised or De-centralised Combined Heat and Power plants (CHPs or DCHPs), Wind Power Plants (WPPs), interconnections with neighbouring power system and coordinated Automatic Generation Control (AGC) system between CHPs and WPPs. The performance of the developed power system model during extreme wind conditions is assessed and discussed by means of set of simulations, where hour-ahead generation schedules in a time scale of five minutes, generated by Simulation power Balancing (SimBa) model, are used as inputs. The conventional generation and the power exchange are using hour-ahead time series, while WPPs generate the available wind power. SimBa, developed by the Danish TSO Energinet.dk together with the Technical University of Denmark, releases an hour-ahead regulating power plan based on day-ahead power production plan and hour-ahead wind power forecast [4]. The hour-ahead forecast and the available wind power are provided by the Correlated Wind power fluctuations (CorWind) model, where the wind turbine storm controllers (HWSD and HWEP) are implemented.

The article is structured as follows. A brief description of the storm controllers, i.e. HWSD and HWEPE is initially provided. Then the proposed active power balance control methodology is described, approaching also the aspects regarding the generation of the hour-ahead (HA) regulating power plan and the AGC. The extreme high wind speed scenarios for the Western Danish power system in year 2020 are used to analyse the active power balance control through a set of simulations with the developed Danish power system model. Finally, conclusive remarks are reported in the final section.

II. Storm Controller

The storm controller ceases power generation from wind turbines during critical weather conditions, to prevent turbine from damage due to extreme mechanical loads. The typical storm controller (HWSD) halts the wind turbine from operation, when wind speed reaches 25 m/s. However, the HWRD functionality enables wind turbines to operate at higher wind speeds with reduced power output, without affecting the structural integrity of the turbine. These storm controllers are briefly described below:

A. High Wind Shut-Down (HWSD)

HWSD is the typical storm controller installed in majority of the wind turbines. The HWSD controller halts the turbine operation when average wind speed reaches to a certain level. The average wind speed is based on 1 second, 30 seconds and 10 minutes. The HWSD behaviour is described by the power curve presented in Figure 1. The sudden cut off may result in active power balance/frequency control issues on power system level, depending on the wind power integration in the power system.

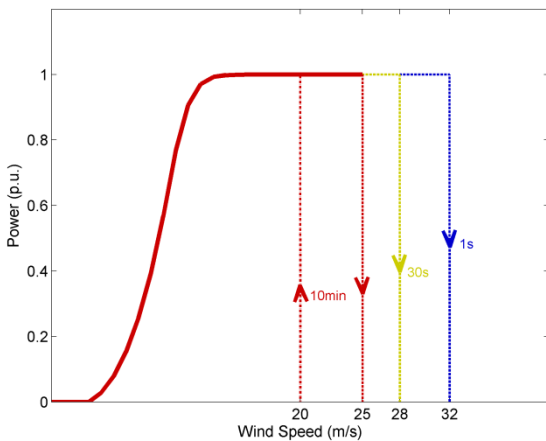

Figure 1: HWSD – wind power curve

B. High Wind Extended Production (HWEPE)

At higher wind speeds, the HWEPE allows production from wind turbine by de-rating the power and speed regularly as a function of wind speed, without impacting the structural integrity of the turbine [3]. The power curve depicting the behaviour of HWEPE controller is shown in Figure 2.

The HWEPE controls generation from wind turbine in two modes, that acts parallel and aren't directly dependent on one another [1]. First operational mode reduces the turbine rotational speed based on the rotor acceleration, by converting the current rotor speed to absolute acceleration. The acceleration value with a gain limits the turbine rotational speed proportional to the increase in wind speed and the turbulence intensity. To avoid high torque on the rotor due to reduction in speed, the power output from the wind turbine is also reduced. In second operational mode, the power output is reduced by controlling the pitch angle. The pitch angle increases as a function of wind speed increase and thus result in a gradual power reduction. Bias values for pitch and rotor acceleration are also assigned with the activation of HWEPE to allow smoother transition in power and speed, rather than a sudden step change.

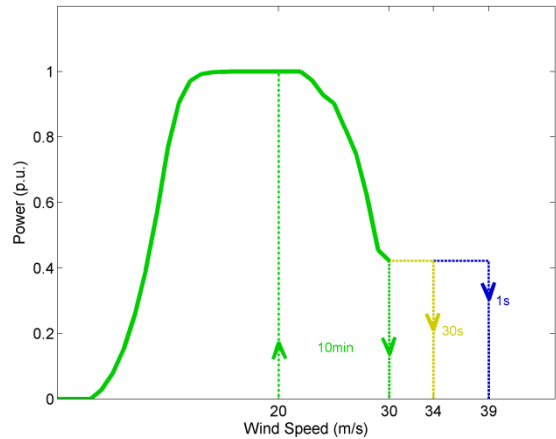

Figure 2 HWEPE – wind power curve

The wind turbine starts again to operate, when the average wind speed drops below certain value. To prevent frequent restarts and shutdowns, the turbine is connected only when the average wind speed reaches to 20 m/s, as shown in Figure 1 and Figure 2.

In this study, HWSD and HWEPE controllers were implemented in CorWind model, to analyse the dynamic behaviour of Danish power system model during high wind speeds.

III. Power balance control

TSOs securely operate the power system in maintaining the active power balance in the power system. In deregulated power systems, the balance is maintained through electricity markets by the balance responsible companies, who can produce, consume or retail. The examples of electricity markets are the day-ahead (DA), hour-ahead (HA) and regulating power markets, where dispatch bids are selected with foremost intent of preserving system integrity and to minimize the production cost. Subsequent to DA market, the HA market modifies the DA dispatch bids before the actual operation period, taking in account the updated wind power forecasts or unavailability of power plants. However in real-time operation, the wind power may be different from the HA forecast, which can lead to active power imbalance in the power system. This power imbalance is then compensated through regulating reserves in the real-time.

In this study, the real time imbalance is caused due to the forecasting error during critical weather conditions and the imbalance is compensated through automatic reserves, i.e. with AGC, when WPPs are equipped with either HWSO or HWEF storm controllers. The following subsections will explain the power balancing model with the generation of HA regulating power plan for the power plants and power exchange with neighbouring power systems and the real time power balance control in the power system with the coordinated AGC dispatch between CHPs and WPPs.

A. Hour-ahead power balance control

Simba, the HA power balancing model, simulate the regulating power plan to ensure the active power balance control in the power system. It uses data input time series from DA market model and HA forecast of wind power to generate regulating power plan for the intra-hour balance with five minute resolution. The DA time series (P_{plan_DA}) are provided by Wind Power Integration in Liberalised Electricity Market (WILMAR), while the Correlated Wind power fluctuations (CorWind) model provides the HA forecast of wind power (P_{WPP_HA}), as shown in Figure 3. The CorWind model also provides the DA forecast of wind power (P_{WPP_DA}) and the available wind power (P_{WPP_avail}). As aforementioned, for the analysis presented in this paper, the storm controllers were implemented in CorWind model to provide P_{WPP_avail} during extreme high wind speeds.

SimBa models the power system taking into account the current grid regulations and the electricity market rules. SimBa uses inputs from WILMAR that include hourly

values for energy production, load and the power exchange between interconnected areas and HA wind power forecasts from CorWind. Based on these inputs, SimBa balances the power system and provides HA five minutes period plan for generating plants and power exchange with neighboring power systems, i.e. P_{plan_HA} .

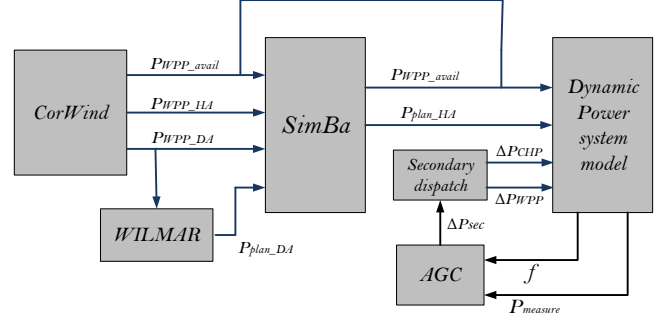

Figure 3: Overview of the signals between CorWind, WILMAR, SimBa, the power system model and the AGC.

During real-time, the power system can come out of balance, if available wind power is not the same as HA forecast. The active power balance is then controlled through activation of regulating bids from the Nordic Operational Information System (NOIS) list in the TSO's control room and also through AGC with a reserved capacity of ± 90 MW, acting on the border of Western Denmark with Germany. However, for the present investigation, it is assumed that the power imbalance is controlled only through AGC.

B. Automatic generation control (AGC)

AGC developed and implemented in this investigation is sketched in Figure 4. It measures the frequency deviation (Δf) from its nominal level and the possible power mismatch (ΔP) between generations (CHPs, DCHPs, and WPPs) and power exchange with neighbouring power systems and system load, as shown in Equation 1. The sum of ΔP with the product of Δf and system frequency bias factor (B) is called the ‘‘area control error’’. B is determined from the droop characteristics of all generating units taking part in the primary response [5]. The area control error (ΔP_{ACE}) is processed by a central controller, usually a PI, which calculates the required change in production (ΔP_{sec}) for the power plants to bring the ΔP_{ACE} to zero (Equation 2).

$$\Delta P = P_{Load} + P_{exchange} - P_G \quad (1)$$

$$P_{ACE} = \Delta P + (\Delta f \times B) \quad (2)$$

As indicated in Figure 4, the change in production ΔP_{sec} is then distributed using the ‘dispatch strategy’ block among the actively participating generators, namely CHPs and WPPs assumed in this study. The dispatch decides the

change in reference power for the participating generating units, i.e. ΔP_{CHP} and ΔP_{WPP} , by using as inputs ΔP_{sec} signal, CHPs power generation (P_{CHP}), WPPs power generation (P_{WPP}) and the available wind power ($P_{\text{WPP_avail}}$) [4].

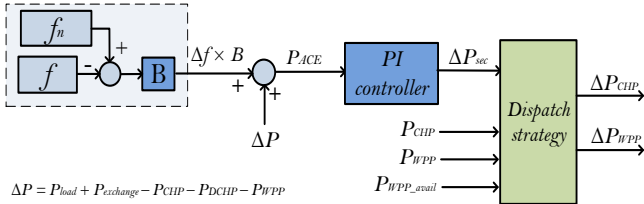

Figure 4: AGC and dispatch strategy model

The dispatch strategy decides the delta set-points for the participating generating units as follows: the WPP is down regulated only when the output of AGC is negative, i.e. $\Delta P_{\text{sec}} < 0$, while the CHP provide secondary responses for positive or negative value of ΔP_{sec} . For down regulation, the WPP will receive reference power signal only when CHP generation touches the lower generation limit or ΔP_{sec} reaches to $\Delta P_{\text{CHP_LowLim}}$, i.e. -90 MW. However, in case of up regulation, i.e. $\Delta P_{\text{sec}} > 0$, only the CHP provides the secondary support, as the WPP is already generating the available wind power.

IV. Power system model

As aforementioned, the future Western Danish power system model is used to study the power balance control during extreme high wind speeds, where generation from WPPs under these conditions are either controlled through HWSD or HWEP storm controllers. This study requires a detailed dynamic representation of the power system that includes conventional power plants, WPPs and the interconnection with neighbouring power systems. The system interconnections and the aggregated power plants models, developed in Power Factory, are explained below.

A. System interconnections

The Western Danish power system is synchronously connected to the strong CE power, via Germany, which offers huge frequency bias. The Western Denmark is also connects to the Nordel power system via HVDC link, i.e. Eastern Denmark, Norway and Sweden. However, there are plans to increase the AC interconnection capacity with Germany and HVDC interconnection capacity with Norway and also to build new HVDC link with Holland [4]. The system interconnections are modelled as simple load accompanied by an external grid, which shows the deviations on AC link in case of power imbalance. The external grid offers the frequency bias and the inertia of the synchronous power system.

B. Power plants modelling

The electrical power generation in Denmark is a combination of conventional and renewable generation sources, where conventional power generation is typically from CHPs and DCHPs and renewable generation is primary based on WPPs contribution. In this study, the aggregated models for these power plants are developed having advantage of a reduced computation effort while maintaining the dynamic features relevant for long term dynamic simulation studies. The power system model developed for this study is based on the description presented in [6 – 9]

Aggregated CHP model reflects the slow boiler response of the thermal power plant [6 – 7]. The boiler and steam turbine response of the CHP is the dominant characteristic for active power balance control in power system studies and can affect the power system stability. Correspondingly, aggregated model for DCHP considers the dynamics of gas turbine [8] and aggregated WPP model takes in account the active power response from the WPPs [9]. SimBa and the AGC provide the power set points for these power plants.

V. Simulation results

A set of simulations are performed using time series for generation, load and power exchange corresponding to a scenario with extreme high wind speeds. The time series are generated by SimBa for the future Danish power system (2020) based on the real data from the year 2009 (October 3 20:00 – October 4 12:00).

The electricity market balances the Danish power system taking in account the HA wind power forecasts. The power system comes out of balance if the available wind power generated within the operating hour differs from the HA forecast. The power imbalance yields to a change in the system frequency and deviation in power exchange from HA schedule. The power imbalance is worse if the forecasting error leads to wind turbine cut off (during storms). Figure 5 shows the real-time power generation from the WPPs during high wind speeds, when conventional storm controller (HWSD) or new storm controller (HWEP) is in operation.

During initial period, the HWSD controller ceases operation from number of wind turbine due to extreme high wind speeds, resulting in a high power imbalance from the HA balance plan, as shown in Figure 6. However, in similar circumstances, the HWEP while safeguarding the turbines structural integrity only deregulates the production from wind turbines, thereby resulting in lower forecasting error and lower power imbalance.

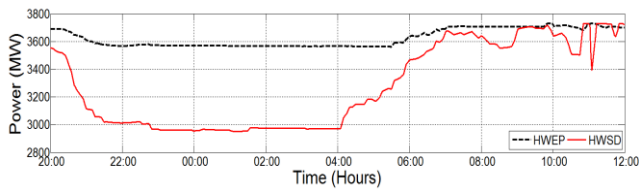

Figure 5: Wind power production – HWEP & HWSD

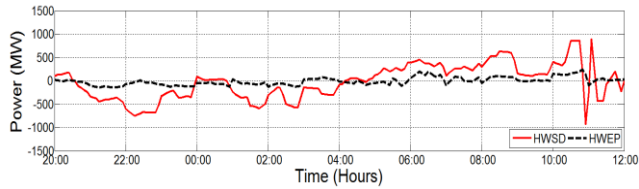

Figure 6: Power imbalance due to HA forecast error

The generating unit instantly responds to the power imbalance by releasing primary reserves. Afterwards, the AGC response reduces the power imbalance in the power system by providing new set points to the participating generating units, i.e. CHP and WPP. The decrease in the power imbalance depends on the reserves availability. The dispatch strategy block in Figure 4 determines the change in reference power set points for CHP (ΔP_{CHP}) and WPP (ΔP_{WPP}). As aforementioned, the WPP only participate in the down regulating process, while CHP contributes in both up and down regulating processes. Also, the ΔP_{WPP} is activated only when CHP are unable to provide the required response, namely that when the ΔP_{CHP} touches the lower limit (-90 MW) or they are operating at their lower generation limit (20% of the online capacity). The delay in overall secondary response will be due to the AGC response, reference power ramp rate (i.e. 30 MW/min considered in this study) and slow boiler response of CHP units, as boiler needs 5 – 6 minutes to modify its output pressure when demanded.

Figure 7 shows the secondary dispatch power for the CHP and WPP, while Figure 8 shows the residual power imbalance after secondary response, when HWSD or HWEP is in operation. During initial operation period (20:00 – 04:30), the high wind speed results in cutting off wind turbines by the HWSD controller and thus large negative power imbalance. The AGC responds to this power imbalance by regulating the reserves from the CHP; however, the power imbalance couldn't be reduced further as the dispatch is limited by +90 MW. In the same operational period, the WPPs couldn't provide any support as they are already generating the maximum possible power. In similar circumstances, the HWEP only reduces the power generation from the wind turbine and thus results in a lower power imbalance which can be compensated by AGC, as shown in Figure 7 and Figure 8.

In later period, the wind turbines again start producing the available wind power, as the average wind speed reduces consequently resulting in generation excess from the HA balance plan. The imbalance is then reduced by manoeuvring the generation from CHPs and WPPs through AGC. The imbalance is high again in case of HWSD controllers, as wind turbines previously taken out of operation starts generating the available wind power.

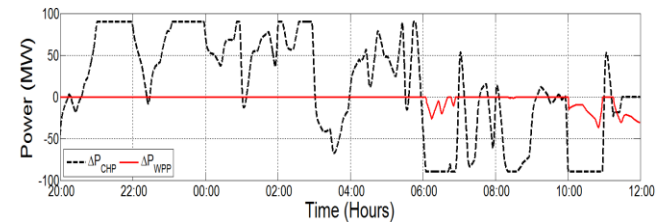
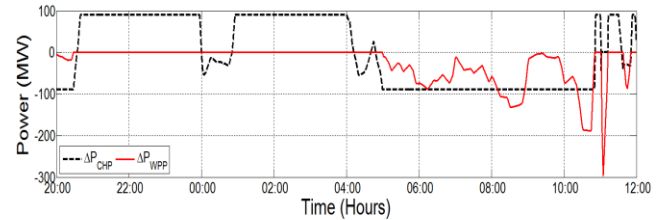

Figure 7: AGC dispatch; top:HWSD, bottom:HWRD

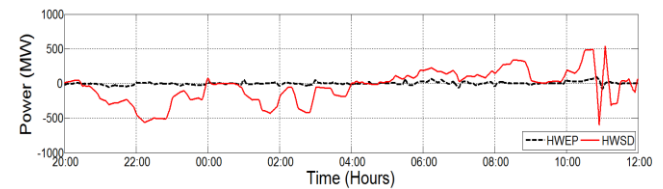

Figure 8: Power deviation after Secondary Response

VI. Conclusion

Large scale integration of wind power challenges the reliable operation of power system, especially during critical weather condition, e.g. extreme high wind speeds. If not forecasted, these conditions may result in a high power imbalance especially for the wind turbines equipped with High Wind Shut Down storm controllers. During extreme high wind speeds, the High Wind Shut Down ceases power generation from wind turbines for their mechanical safety. Analogously, the wind turbine with High Wind Extended Production will only de-rate their generation, thus safeguarding their structural integrity and resulting in less power imbalance during real-time.

This study analyses the active power balance control in future Western Danish power system during extreme high wind speeds, when WPPs are either controlled with High Wind Shut Down storm controller or High Wind Extended Production storm controller. From the results, it can be concluded that High Wind Shut Down results in high power imbalances which can't be fully compensated with primary

and secondary reserves, and therefore residual power imbalance can affect the reliable system operation. However, controlling the wind turbines with High Wind Extended Production will result in less power imbalance and thus assures safe operation of the power system during critical weather conditions.

VII. Acknowledgement

This paper is a part of PhD project funded by Sino-Danish centre for education and research (SDC).

VIII. References

- [1] Cutululis NA, Litong-Palima M, Sørensen PE, Bjerger, MH & Detlefsen, N, "Impact of High Wind Speed Shut-down in the Danish Power System," in 12th International Workshop on Large-Scale Integration of Wind Power into Power Systems as well as on Transmission Networks for Offshore Wind Power (WIW 2013), 2013.
- [2] Vittrup C, "2013 was a record-setting year for Danish wind power," Energinet.dk, 2014.
- [3] Cutululis NA, Litong-Palima M, Sørensen PE, "Offshore Wind Power Production in Critical Weather Conditions," in Proceedings of EWEA 2012 - European Wind Energy Conference & Exhibition. European Wind Energy Association (EWEA), 2012
- [4] Basit A; Hansen AD, Altin M, Sørensen P, Gamst M, "Wind power integration into the automatic generation control of power systems with Large-scale wind power," IET - JoE, 2014.
- [5] Prabha K, Power System Stability and Control, McGraw-Hill, 1994.
- [6] I.C. Report, "Dynamic Models for Steam and Hydro Turbines in Power System Studies," IEEE Transactions on Power Apparatus and Systems, Vols. PAS-92, no. 6, pp. 1904-1915, November 1973.
- [7] IEEE Committee Report, "Dynamic models for fossil fueled steam units in power system studies," IEEE Transaction on Power Systems, vol. 6, no. 2, pp. 753-761, May 1991.
- [8] CIGRE Task Force 25 of Advisory Group 02 of Study Committee C4, "Modeling of Gas Turbines and Steam Turbines in Combined Cycle Power Plants," CIGRE, 2003.
- [9] IEC 61400-27 Committee Draft, Wind Turbines Part 27-1, "Electrical simulation models for wind power generation Wind turbines," IEC Std. committee Draft (CD) 88/424/CD, 2012.

P5: Basit A.; Hansen A. D.; Altin M.; Sørensen P.: “Balancing modern Power System with large scale of wind power”, China Wind Power (CWP), Beijing, 2014

Balancing modern Power System with large scale of wind power

A. Basit^{1,*§}, M. Altin^{*}, A.D. Hansen^{*} and P. Sørensen^{*}

^{*} Technical University of Denmark, Department of Wind Energy, Frederiksborgvej 399, Building 125, 4000 Roskilde, Denmark

[§] Sino-Danish Center for Education and Research, Niels Jensens Vej 2, 8000 Aarhus, Denmark

Abstract – Power system operators must ensure robust, secure and reliable power system operation even with a large scale integration of wind power. Electricity generated from the intermittent wind in large proportion may impact on the control of power system balance and thus deviations in the power system frequency in small or islanded power systems or tie line power flows in interconnected power systems. Therefore, the large scale integration of wind power into the power system strongly concerns the secure and stable grid operation. To ensure the stable power system operation, the evolving power system has to be analysed with improved analytical tools and techniques. This paper proposes techniques for the active power balance control in future power systems with the large scale wind power integration, where power balancing model provides the hour-ahead dispatch plan with reduced planning horizon and the real time imbalances are minimized with automatic generation controller and the programmed to regulate active power reserves.

Keywords – Power balance control, Large scale wind power integration, AGC and Inaccurate wind forecast

1 Introduction

Electricity generation from wind power has increased significantly during the last decade. Wind power is increasingly being viewed as a mainstream electricity supply technology as it has very low CO₂ lifetime emission, significantly exploitable resource potential, no cost uncertainties from fuel supply price fluctuations, can be rapidly installed and opportunities for industrial, economic and rural development. Therefore, globally 318 GW of wind power capacity has been installed till the end of 2013, where 35 GW was only installed in 2013 [1]. China holds the largest capacity of wind power plants worldwide with 91.4 GW of installed wind power. Other countries having large wind power capacities are United States (61 GW), Germany (34.2 GW), Spain (22.95 GW) and India (20.15 GW) [1].

Denmark being the pioneer of electricity generation from wind power is among the top 10 countries having the largest wind power capacity. It has worldwide the highest wind power penetration level with respect to the total generation, with the generating capacity of 4.79 GW [2]. The installed wind power generated 11.1 TWh during the year 2013 and shares 33.2% of the electricity generation in the entire year, when the total electricity generation in the Danish grid was 33.5 TWh [2].

In the future, these levels are expected to be increased according to the political and environmental policies. Therefore, large scale integration of wind power into the power system may risk the secure and stable grid operation without consideration of the wind variability. The problems that need to be addressed include frequency control, power balance control, voltage stability, reserves and transmission capacity [3]. Frequency control problems are more prominent in small and islanded power systems. Accordingly, in a large interconnected power system, such as Denmark connected to European power system, power balance is one of the main challenges that need to be evaluated for large scale integration of wind power. Wind power forecast contributes considerably to the power balance control, as the inaccurate wind forecast disrupts the cost effective generation schedule and could reduce system stability. The system operators concerns on how to integrate a significant amount of this intermittent wind power without disrupting the power system balance control.

¹Corresponding author: Tel.: +45 2492 1623; Fax: +45 4677 5083; E-mail address: abdl@dtu.dk (A. Basit)

The paper presents a platform for the active power balance control in a large scale wind power integrated power system. This methodology consists of a dynamic power system model implemented in Powerfactory DigSilent with hour-ahead active power set values for the conventional generation and consumption, and the forecasted wind power from Simulation power Balancing (SimBa) tool. Consequently, the simulation results will be presented for an example of Danish power system as a benchmark of the proposed platform. A dynamic power system model for long term dynamic simulations studies has been developed, representing relevant dynamic features of the power plants and compensates for imbalances between load and generation by regulating the active power production in real time. The present developed power system model includes models for the Automatic Generation Control (AGC) system, centralised or de-centralised Combined Heat and Power plant (CHP and DCHP), Wind Power Plant (WPP) and interconnections with neighbouring power systems. The highly wind power integrated power system model is using hour-ahead schedule information on power generation, power demand and power exchange as input, with five minute dispatch plan. The hour-ahead plan is generated by SimBa model, developed by the Danish TSO (Energinet) together with the Technical University of Denmark.

The paper is structure as follows; a brief description of the impact of inaccurate wind power forecast in a highly wind power integrated power system is provided in Section II. The implemented power system model with high share of wind power is then described in Section III, while power balancing techniques and simulation results are shown and analysed in Section IV. Finally, Section V draws the partial conclusions of this study.

2 Impact of inaccurate wind power forecast

Power system must keep the supply and demand power in close balance at all times. In traditional power systems, the average load almost varies in predictable patterns, except for the unforeseen events. These variations are compensated in real time through additional generation capacity kept as reserves. Introducing wind generation can increase the regulation burden and need for reserves, due to its natural intermittency. Wind power impacts the reliable power system operation and it depends on their penetration level, and also on the power system size, generation capacity mix, load variation and the interconnection with neighbouring power systems. The intermittent nature of wind power may lead to a power balancing problems in a highly wind power integrated power system can deviate the system frequency from its nominal level and the tie line power exchange from planned and cost effective generation schedule. The large scale integration of wind power therefore challenges the system operators to maintain a close balance between production and consumption in their individual power systems and the tie line interchange at its schedule.

Wind power forecast plays an important role in this regard, as for example. in a current Danish power system, a single m/s increase or decrease in a wind speed between 5 – 15 m/s will generate a power imbalance of approximate 350 MW [4]. The developed control methods and the available reserves are suitable to deal with the variable wind power supply in the existing power systems. However, operation and control methods need to be reviewed for future integration of wind power as wind power plants will be replacing the conventional power plants in modern power system.

3 Power system modelling

Power system model has been developed to study the active power balance control in a modern power system with high wind power penetration level, where more than 50% of the electricity is generated by the wind power. The developed power system model reflects the most relevant dynamics of the power system with respect to active power balancing control issues. It includes the AGC system, aggregated models for the CHP, DCHP and WPP and the interconnections with neighbouring power system, as shown in Figure 1.

The response time and ramp rates associated with CHP and DCHP models are in order of minutes and are the dominant characteristic for power system studies. An aggregated CHP model consists of a thermal boiler, a boiler turbine controller, a steam turbine and a speed governor, while, an aggregated DCHP model includes gas turbine and a speed governor. The speed governor of the generating units activates the primary reserves, i.e. Frequency Containment Reserves (FCR), if the frequency deviates by ± 0.01 Hz. The amount of FCR depends on the droop characteristic of the governor of each generating unit (i.e. 4% in this study) and the available capacity. The reference power signal for the conventional generating units is calculated from the hour-ahead schedule generated by SimBa and the power correction from the AGC, i.e. Frequency Restoration Reserves (FRR). The CHP power plant also activates the regulating reserves, i.e. Replacement Reserves (RR), to reduce the real time imbalance in the power system.

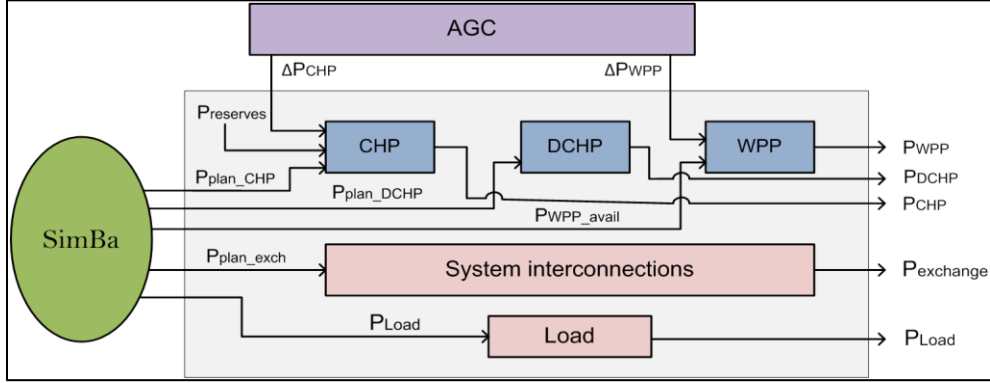

Figure 1: Power system model

An aggregated WPP model is also modelled for the active power control purpose, where the power reference is decided based on the available wind power, primary response and the secondary response from an AGC.

4 Techniques for balancing power system operation

In deregulated power systems, the electricity is traded in electricity markets by the balance responsible companies that can produce, consume or retail. The balance responsible balances the power system for every operating period to one hour in advance of the actual operation hour. The unpredictable wind nature or other non-contingent events might create power imbalance within the actual operating hour. These imbalances are then minimized in real time by primary and secondary responses and also by activating the reserve power, within minutes, from regulating power market.

To study the power system balance operation with large scale of wind power, a specific day is considered when conventional power plants generated 33.15 GWh of electricity, while wind power generated 43.22 GWh, i.e. 56.59% of the total electricity production, with total load demand of 43.76 GWh. The hour-ahead balance power schedule is provided by SimBa and the real time imbalances are compensated by varying the production from CHP and WPP using an AGC and also by programmed control of regulating reserves.

4.1 Hour-head balancing operation

Conventional market models are simulating optimal unit commitment and dispatch of generation units with one hour resolution, based on input time series for consumption and renewable power generation [5]. However to cope with the inaccurate wind power forecast in a highly wind power integrated power system, it is needed to activate the dispatch power with reduced planning horizon in order to decrease the real time regulating burden. SimBa releases an hour-ahead dispatch plan in a time scale of five minutes to manage the power imbalances in a highly wind power integrated power system. It takes hour-ahead wind power forecasts, estimates the wind power fluctuation within each operating hour and calculates the available wind power with a five minute

time resolution. Based on the simulated hour-ahead wind power forecast and the day-ahead power production plan from the spot market, it provides dispatch plan for generating units and power exchange with neighbouring power system. However due to the uncertain nature of wind, the wind power within the operating hour may not be the same as its estimated value and this aspect can create power imbalance within the operating hour. The amount of power imbalance seen by the developed power system model in this study, using hour-ahead schedule from SimBa, is shown in Figure 2. The figure also shows the hour-ahead wind power forecast error during the same period.

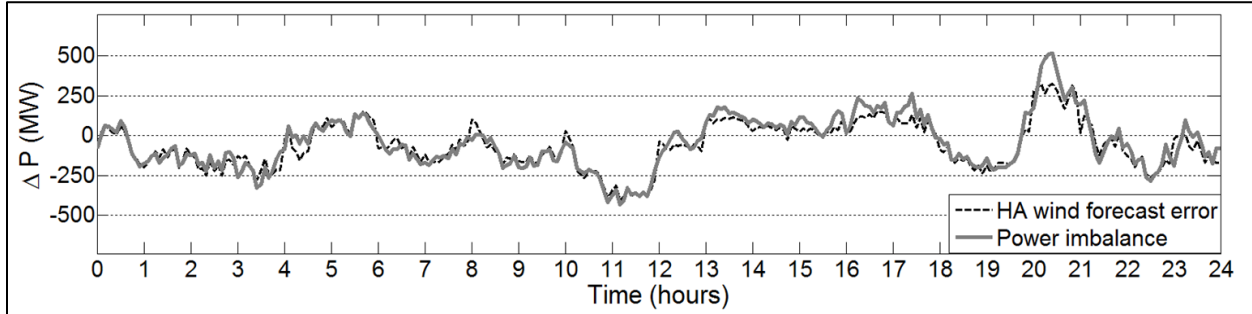

Figure 2: Power imbalance and wind forecast error

The power imbalance within the operating hour is due to the hour-ahead wind power forecast error, as Figure 2 compares the two power imbalances. The power imbalance will deviate the system frequency from its nominal level and the interchange power from hour-ahead schedule. The power imbalance is minimized in real time by adjusting the production from CHP and WPP in real time.

4.2 Real time balance operation

Active power reserves are always needed to keep the power system in balance and their amount depends also on the wind power penetration level and wind power forecast. The reserves are typically needed from fast conventional generating units to increase the system reliability and to ensure the power supply security. According to European Network of Transmission System Operators for Electricity (ENTSO-E), the type of reserves needed to keep the power system in balance can be classified as FCR, FRR and RR. In this study, the FCR is activated from all generating units; FRR is automatically activated from CHP and WPP through an AGC and RR only from CHP.

The generating units of the developed power system model responds to the power imbalance shown in Figure 2, by activating the FCR within 30 seconds for constant containment of frequency deviations and to constantly maintain the power balance in the whole synchronously interconnected system. The AGC responds afterwards and activates the FRR within 5 – 10 minutes, in order to maintain the active power balance in the power system and the power exchange with neighbouring power system at its schedule. The activation of FRR will also replace the FCR. Figure 3 shows and compare the power imbalance in the power system after the activation of FRR and the hour-ahead power imbalance.

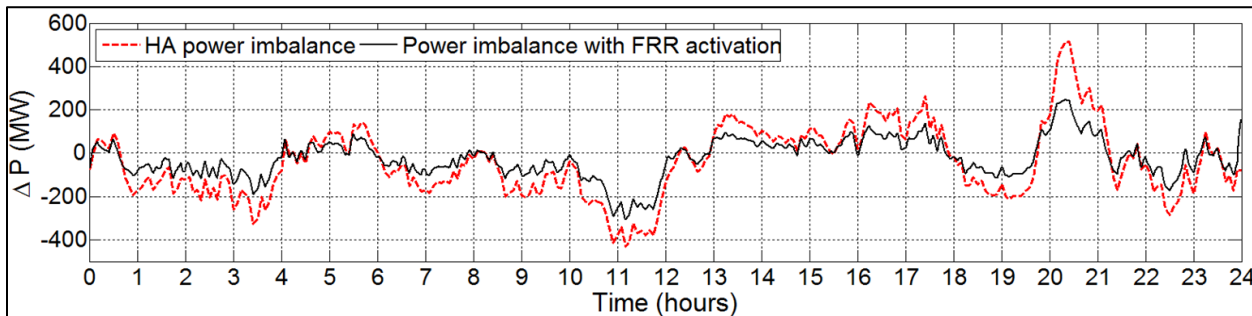

Figure 3: Power imbalance after FRR

The AGC activates the FCR with a coordinated control strategy between the CHP and the WPP. The CHP participate in up or down active power regulation, whereas the AGC down regulates the active power production from WPP only in case of generation excess and when CHP operate at their minimum limits or CHP dispatch reaches its lower limit. The AGC strategy integrates the WPP efficiently in secondary control by down regulating their production only in case of generation excess and utilizes the available wind power in case of generation deficiency.

The remaining power imbalance after the AGC response is minimized by the programmed activation of RR. These reserves are activated from CHP by an algorithm, designed to simulate the actions similar to the control room to tackle the real time power imbalances. The developed algorithm activates the regulating bids to reduce the real time power imbalances in the power system and make power system operation more reliable. The power imbalance after the activation of RR is compared in Figure 4 with the hour-ahead power imbalance and the power imbalance after AGC response. It can be seen that the imbalance has substantially reduced in a power system, where more than 50% of the total electricity is generated by wind power.

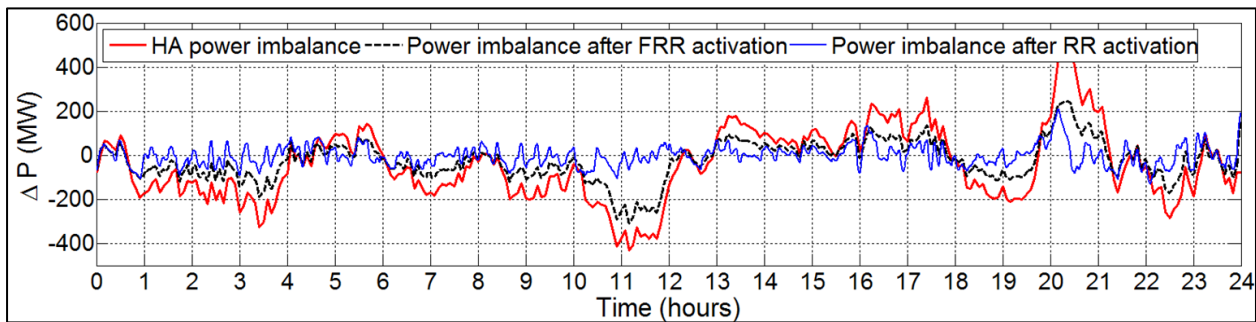

Figure 4: Final Power Imbalance

5 Conclusion

The integration of large amounts of wind power into the power system results in an extraordinary challenges e.g. power system balance control. The regulating reserves and its effective control are always needed to maintain active power in close balance. This paper proposes a platform for active power balance control, where hour-ahead dispatch plan with reduced planning horizon minimizes the real time regulation burden and the AGC with programmed control of regulating reserves makes the power system operation more reliable. The study performed and presented in this paper shows how power imbalances between load and generation, caused by wind power forecast error, can be compensated effectively by regulating the power from CHP and WPP in real time. The algorithm activates the regulating power from CHP while the AGC provides the required secondary response from CHP and WPP. However, better forecasting of wind speed and the load demand is still desirable for operational security of highly wind power integrated power system.

Acknowledgement

This paper is a part of PhD project funded by Sino-Danish center for education and research (SDC).

References

- [1] Global Wind Energy Council, "Global Wind Statics 2013", February 2014 [online], http://www.gwec.net/wp-content/uploads/2014/02/GWEC-PRstats-2013_EN.pdf
- [2] Vittrup C, "2013 was a record-setting year for Danish wind power" Energinet.dk, 15 January 2014 [online] <http://energinet.dk/EN/EI/Nyheder/Sider/2013-var-et-rekordaar-for-dansk-vindkraft.aspx>
- [3] Suwannarat A (2007), "Integration and Control of Wind Farms in the Danish Electricity System," Institute of Energy Technology Aalborg University, Aalborg

[4] Energinet.dk, “Wind Power to combat Climate Change”, [online] <http://energinet.dk/SiteCollectionDocuments/Engelske%20dokumenter/Klimaogmiljo/Wind%20power%20magazine.pdf>

[5] Sørensen P, Norheim I, Meibom P and Uhlen K (2007), “Simulations of wind power integration with complementary power system planning tools,” Electric Power Systems Research, p. 1069–1079

P 6: Basit A.; Hansen A. D.; Sørensen P.: “Dynamic model of frequency control in Danish power system with large scale integration of wind power”, China Wind Power (CWP), Beijing, 2013

Dynamic model of frequency control in Danish power system with large scale integration of wind power

A. Basit^{1,2,3}, A.D. Hansen¹, P. Sørensen¹

¹ Technical University of Denmark, Department of Wind Energy, Wind Energy Systems, DTU Risø Campus, Frederiksborgvej 399, Building 125, 4000 Roskilde, Denmark

² Sino-Danish Center for Education and Research, Niels Jensens Vej 2, 8000 Aarhus, Denmark

³ Corresponding author. Tel.: +45 2492 1623; Fax: +45 4677 5083; E-mail address: abdl@dtu.dk (A. Basit)

Abstract – This work evaluates the impact of large scale integration of wind power in future power systems when 50% of load demand can be met from wind power. The focus is on active power balance control, where the main source of power imbalance is an inaccurate wind speed forecast. In this study, a Danish power system model with large scale of wind power is developed and a case study for an inaccurate wind power forecast is investigated. The goal of this work is to develop an adequate power system model that depicts relevant dynamic features of the power plants and compensates for load generation imbalances, caused by inaccurate wind speed forecast, by an appropriate control of the active power production from power plants.

i. Introduction

Large scale future integration of wind power jeopardizes the reliability of the Danish power system operation. In this context, wind speed forecast plays an important role. For example an incorrect wind speed forecast implies that the generation and the power exchange plan with neighboring power systems deviate from their schedule. This issue can lead to power system balancing and control problems and can introduce several challenges in maintaining a reliable power system operation.

In spite of these challenges, the interest in the integration of large future wind power into power systems has motivated and accelerated new opportunities in modeling and control research of power systems. Adequate power system models and control strategies for long term dynamic simulations are for example desirable in the study of the active power balance control during imbalances in the power system, which is in focus in this present work. To manage the imbalances due to wind speed forecasting errors, Automatic Generation Control (AGC) strategies need for example to be revised to ensure safe, reliable and economical operation of the power system [1]. Moreover, an appropriate amount of reserves is required from fast conventional generating units to cope with the imbalances caused by uncertain wind nature.

This paper focuses therefore on developing a dynamic power system model which includes models for the Automatic Generation Control (AGC) system, centralized and de-centralized Heat and power (CHP and DCHP) units, full scale converter variable speed wind turbines (Type IV) and the interconnections with neighboring power system.

As described in [1] & [2], the eastern and western Danish power systems are synchronously connected to NORDEL and UCTE systems, respectively. An HVDC transmission line, namely the Great Belt link, connects the eastern and western Danish power systems. An overview of the active power balance control flow in the Danish power system model with the AGC contributions from conventional generating units, depicting, is shown in Figure 1.

The objective of this study is to illustrate how load generation imbalances caused by inaccurate wind speed forecast can be compensated by regulating the active

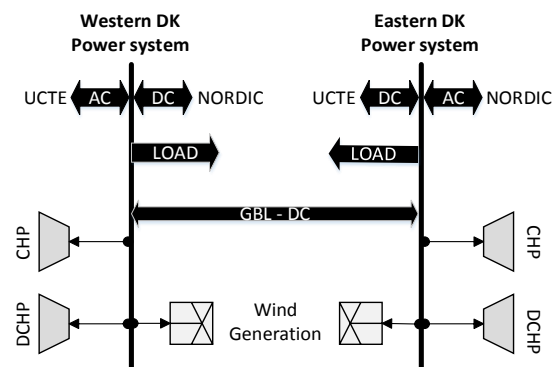

Figure 1: Danish power system model overview

power production from conventional power plants. The present power system model is developed to be able to reflect the dynamics of a power system with high wind power integration, as it is the case of the Danish power system in the future.

The paper is structured as follows. A brief description of the impact of the fluctuation nature of the wind on the power system operation is provided in Section II. The implemented power system model is then described in Section III, while simulation results are shown and analyzed in Section IV. Finally, Section V draws the partial conclusions and provides an outlook of the future work.

ii. Impacts on Power system operation

Wind speed is always fluctuating and so is the power generated from wind turbines. In interconnected power systems with large integration of wind power, one of the main challenges for the transmission system operator (TSO) is to maintain the active power balance in the power system in spite of wind power fluctuations. The active power reserves are needed to keep the system in balance and it depends on the level of wind power integration in power system and on weather conditions. For example, extreme weather conditions may result in loss of large amount of wind power within few minutes, jeopardizing the reliability and the security of the power system operation. Therefore spinning and secondary reserves [2] are needed from fast conventional units to increase the system reliability and makes its operation more secure. In this study the reserves from CHPs and DCHPs are used to maintain the power balance in power system and power exchange with neighboring power system at its scheduled level.

iii. Power system model

A power system model, suitable for long term dynamic simulation studies, has been developed in this work to study the active power control. It includes models for centralized and de-centralized Heat and power (CHP and DCHP) units, full scale converter variable speed wind turbines (Type IV), an Automatic Generation Control (AGC) system and for the interconnections with neighboring power system.

The models for the power units (CHPs and DCHPs) are developed in order to be able to depict different relevant dynamic features of the power plants.

An aggregated CHP model is for example developed based on the studies described in [1] to [4]. The CHP model, shown in Figure 2, consists of a speed governor, a boiler and a steam turbine. The model replicates the dynamic characteristics of the thermal boiler that can affect the real power system operation.

An aggregated DCHP model is developed in this work based on studies described in [1], [2] & [5]. Figure 3 shows the implemented DCHP model with a speed governor and a simple cycle gas turbine. It reflects the faster response of all other conventional units than CHP in the Danish power system.

An aggregated wind farm model of a Type IV wind turbine is implemented based on the description provided in [6] & [7]. The wind turbine model, shown in Figure 4, can function both for normal operation or curtailed operation. It consists of a pitch controller, an aerodynamic model, a 2-mass mechanical model and a maximum power point tracking table (MPPT) as well

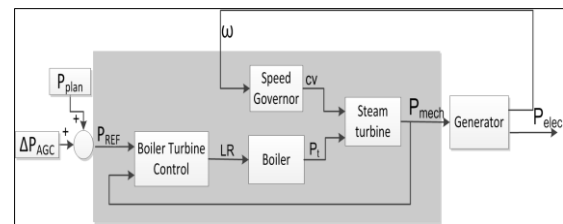

Figure 2: Aggregated CHP model – source [1] - [4]

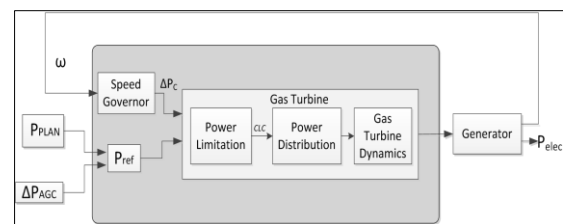

Figure 3: Aggregated DCHP model – source [1], [2] & [5]

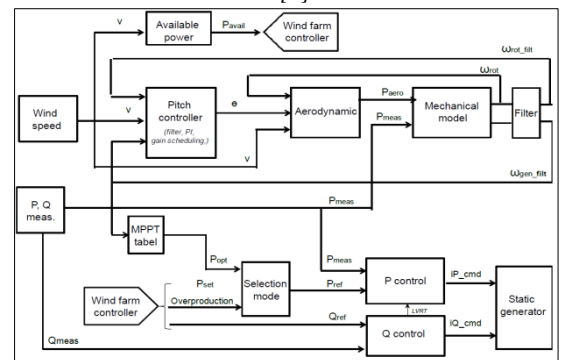

Figure 4: Aggregated Type IV wind turbine – source [6] & [7]

as an active and reactive power controller.

The power system model is developed taking into account the ramping capabilities of the generating units and the exchange power with neighboring power systems. It is worth mentioning that Denmark's neighboring power systems do not have same ramp rates for power exchange. For example, in the Nordel power system, the agreed exchange power shall be ramped within 30 minutes and shall begin 15 minutes before the agreed exchange hour. In the UCTE power system, the exchange power shall be ramped within 10 minutes and starts 5 minutes before the agreed exchange hour.

As well known, any imbalance in the active power will result in frequency deviation from its nominal level.

The speed governors of the power plants in operation sense the frequency change and releases primary reserves to stabilize the system frequency. The frequency is fully restored to its nominal level by secondary control, which is activated either manually by changing the generator power set point or automatically through an AGC. In Denmark, the secondary reserves are activated manually, apart from a load frequency controller (± 90 MW) in western Denmark with Germany border to respond to any deviations from scheduled plan. Therefore it is relevant to study AGC in this project. The implemented AGC in this work is shown in figure 5. Notice that it changes the generators active power set point depending on power imbalance in power system i.e. area control error (ACE) and their participation factors.

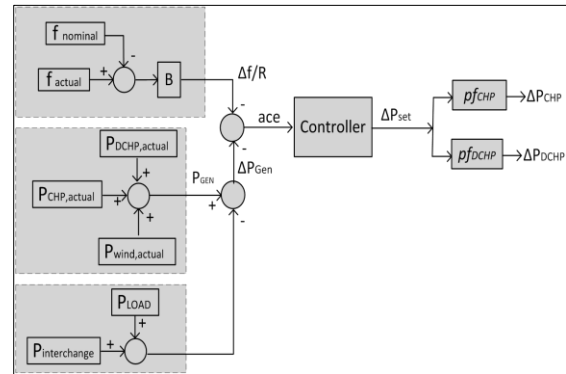

Figure 5: AGC model

iv. Simulation studies

In this section, different studies are carried out in order to illustrate the dynamic features of the implemented power system model with respect to the active power balance control. A set of simulations are performed using time series for generation, load and power exchange corresponding to one particular winter day with high wind speed. These time series are the assumptions from the Danish TSO for future power system where wind generating units have almost the same capacity as conventional generating units. On this particular day, the power generated from wind turbines and conventional units as well as the load demand in eastern and western Danish power system are shown in Figure 6 & 7, respectively. The availability of wind on this particular day allows the wind turbines to generate more power than conventional generating units.

According to [2], in Denmark, the electricity markets are balanced on hourly basis taking into account the hour ahead forecasted value of wind and load. Based on these forecasts, the generating unit's set points are decided for balancing the power system. If the actual wind power generated within the operating hour is not the same as the forecasted one, it will result in a power mismatch between generation and load. Figure 8 show the wind power deviation from its hour ahead predicted value in eastern and western Danish power system. The

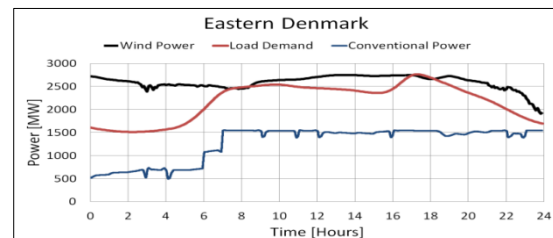

Figure 6: East Dk - Generation

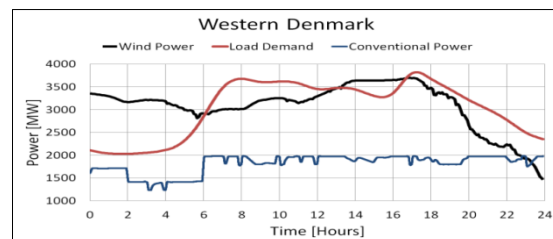

Figure 7: West Dk - Generation

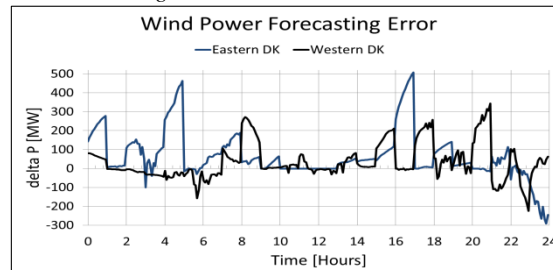

Figure 8: Wind Power forecast error

deviation in wind power is as follows:

$$P_{error}^{wind} = P_{actual}^{wind} - P_{hour\ ahead}^{wind} \quad (1)$$

The wind forecasting error creates an imbalance between generation and load, which yields to a change in the system frequency. The process is as following, the speed governors provide the initial support by releasing the primary reserves automatically. Afterwards the AGC provides new set point to the generators based on their participation factors and the ACE. The support from conventional generating units to reduce the imbalance power can be seen in Figure 6 & 7 as spikes at start of each hour and the ramp within an hour.

Figure 9 & 10 shows the power imbalance in eastern and western Denmark power system respectively, while Figure 11 & 12 shows the corresponding system frequencies in these power systems. The power imbalance in these power systems do not return to zero although the AGC changes the generators set points. The reason is that the AGC output is limited to ± 90 MW, which restricts the secondary action from providing the power equal to wind power forecast error. The huge spikes in these figures are due to the different power exchange ramp rates with neighboring power systems, as mentioned before, namely the Nordel and UCTE power systems have different ramp rates and power exchange starts at different times. This means that if the power has to be transported from one power system to another, it will end in power surplus or deficit in the Danish power system at the commencement of each hour and will result in power imbalance.

The illustrated deviation in the system frequency corresponds to the amount of power imbalance. The surplus power results in frequency rise while the deficit in frequency drop. Notice that, in spite of huge power imbalance as illustrated in the future Danish power system, the system frequency remains within the normal range i.e. 49.9 – 50.1 Hz. This is because that the Danish power system is synchronously connected to stiff and large electrical network of UCTE and Nordel. They offer enormous frequency bias, which avoids frequency abnormality in Danish power system even with large scale integration of wind power.

v. Conclusion

This paper studies the impact of large scale integration of wind power on power system operation. An adequate Danish power system model is developed to analyze the system behavior during power imbalance, where key reason for an imbalance is an inaccurate wind speed forecast. The model examines the reliability and the security of power system pertaining to power deviation from its schedule. Thus the availability of reserves, specified control strategy and interconnection with strong electrical networks decides the level of integration of wind power in any power system.

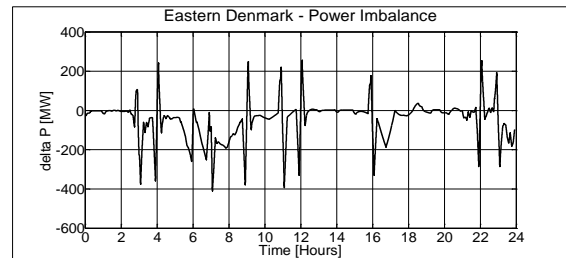

Figure 9: Imbalance power in East DK

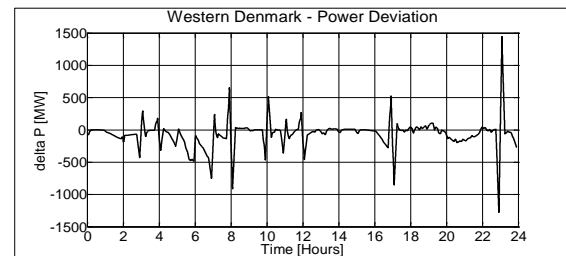

Figure 10: Imbalance power in West DK

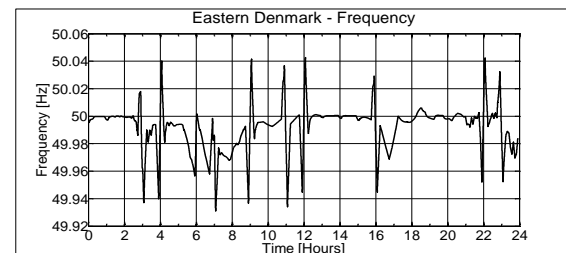

Figure 11: System frequency East DK

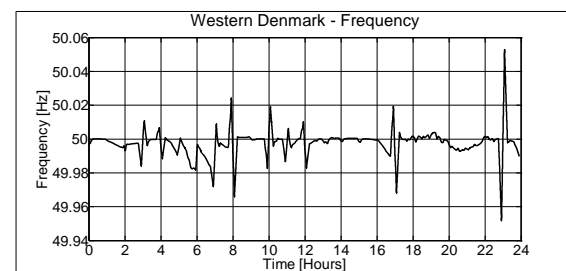

Figure 12: System frequency West DK

vi. Acknowledgement

The author would like to thank Sino-Danish center for education and research (SDC) for funding this PhD project

vii. References

- [1]: A. Suwannarat, "Integration and Control of Wind Farms in the Danish Electricity System", Phd thesis, Institute of Energy Technology, Aalborg University, 2007.
- [2]: Georgios Giannopoulos, 'Frequency control in area with large scale wind power', Master thesis, July 2012
- [3] F. De Mello, "Dynamic models for fossil fueled steam units in power system studies," IEEE Transaction on Power Systems, vol. 6, pp. 753-761, 1991.
- [4] R. Byerly, "Dynamic models for steam and hydro turbines in power system studies," IEEE Transactions on Power Apparatus and Systems, pp. 1904-1915, 1973
- [5] "CIGRE Task Force 25 of Advisory Group 02 of Study Committee C4 (Task ForceC4.02.25), "Modeling of Gas Turbines and Steam Turbines in Combined CyclePower Plants", 2003.
- [6] Hansen A.D., Margaris I. Germán C. Tarnowski, Florin Iov, 'Simplified Type 4 wind turbine modeling for future ancillary services', EWEC 2013
- [7]: Hansen A. D., Margaris I., "Type IV Wind Turbine Model", DTU wind energy, 2013

P7: Basit A.; Hansen A.D.; Margaris I.D.; Hansen J.C., "A Review of Grid Requirements for Wind Farm in Denmark and China", China Wind Power (CWP), Beijing, 2012

Dynamic model of frequency control in Danish power system with large scale integration of wind power

A. Basit^{1,2,3}, A.D. Hansen¹, P. Sørensen¹

¹ Technical University of Denmark, Department of Wind Energy, Wind Energy Systems, DTU Risø Campus, Frederiksborgvej 399, Building 125, 4000 Roskilde, Denmark

² Sino-Danish Center for Education and Research, Niels Jensens Vej 2, 8000 Aarhus, Denmark

³ Corresponding author. Tel.: +45 2492 1623; Fax: +45 4677 5083; E-mail address: abdl@dtu.dk (A. Basit)

Abstract – This work evaluates the impact of large scale integration of wind power in future power systems when 50% of load demand can be met from wind power. The focus is on active power balance control, where the main source of power imbalance is an inaccurate wind speed forecast. In this study, a Danish power system model with large scale of wind power is developed and a case study for an inaccurate wind power forecast is investigated. The goal of this work is to develop an adequate power system model that depicts relevant dynamic features of the power plants and compensates for load generation imbalances, caused by inaccurate wind speed forecast, by an appropriate control of the active power production from power plants.

i. Introduction

Large scale future integration of wind power jeopardizes the reliability of the Danish power system operation. In this context, wind speed forecast plays an important role. For example an incorrect wind speed forecast implies that the generation and the power exchange plan with neighboring power systems deviate from their schedule. This issue can lead to power system balancing and control problems and can introduce several challenges in maintaining a reliable power system operation.

In spite of these challenges, the interest in the integration of large future wind power into power systems has motivated and accelerated new opportunities in modeling and control research of power systems. Adequate power system models and control strategies for long term dynamic simulations are for example desirable in the study of the active power balance control during imbalances in the power system, which is in focus in this present work. To manage the imbalances due to wind speed forecasting errors, Automatic Generation Control (AGC) strategies need for example to be revised to ensure safe, reliable and economical operation of the power system [1]. Moreover, an appropriate amount of reserves is required from fast conventional generating units to cope with the imbalances caused by uncertain wind nature.

This paper focuses therefore on developing a dynamic power system model which includes models for the Automatic Generation Control (AGC) system, centralized and de-centralized Heat and power (CHP and DCHP) units, full scale converter variable speed wind turbines (Type IV) and the interconnections with neighboring power system.

As described in [1] & [2], the eastern and western Danish power systems are synchronously connected to NORDEL and UCTE systems, respectively. An HVDC transmission line, namely the Great Belt link, connects the eastern and western Danish power systems. An overview of the active power balance control flow in the Danish power system model with the AGC contributions from conventional generating units, depicting, is shown in Figure 1.

The objective of this study is to illustrate how load generation imbalances caused by inaccurate wind speed forecast can be compensated by regulating the active

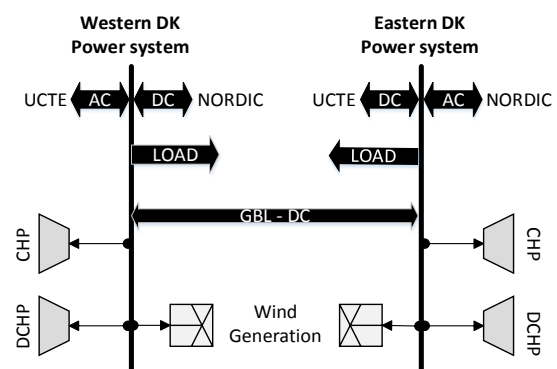

Figure 1: Danish power system model overview

power production from conventional power plants. The present power system model is developed to be able to reflect the dynamics of a power system with high wind power integration, as it is the case of the Danish power system in the future.

The paper is structured as follows. A brief description of the impact of the fluctuation nature of the wind on the power system operation is provided in Section II. The implemented power system model is then described in Section III, while simulation results are shown and analyzed in Section IV. Finally, Section V draws the partial conclusions and provides an outlook of the future work.

ii. Impacts on Power system operation

Wind speed is always fluctuating and so is the power generated from wind turbines. In interconnected power systems with large integration of wind power, one of the main challenges for the transmission system operator (TSO) is to maintain the active power balance in the power system in spite of wind power fluctuations. The active power reserves are needed to keep the system in balance and it depends on the level of wind power integration in power system and on weather conditions. For example, extreme weather conditions may result in loss of large amount of wind power within few minutes, jeopardizing the reliability and the security of the power system operation. Therefore spinning and secondary reserves [2] are needed from fast conventional units to increase the system reliability and makes its operation more secure. In this study the reserves from CHPs and DCHPs are used to maintain the power balance in power system and power exchange with neighboring power system at its scheduled level.

iii. Power system model

A power system model, suitable for long term dynamic simulation studies, has been developed in this work to study the active power control. It includes models for centralized and de-centralized Heat and power (CHP and DCHP) units, full scale converter variable speed wind turbines (Type IV), an Automatic Generation Control (AGC) system and for the interconnections with neighboring power system.

The models for the power units (CHPs and DCHPs) are developed in order to be able to depict different relevant dynamic features of the power plants.

An aggregated CHP model is for example developed based on the studies described in [1] to [4]. The CHP model, shown in Figure 2, consists of a speed governor, a boiler and a steam turbine. The model replicates the dynamic characteristics of the thermal boiler that can affect the real power system operation.

An aggregated DCHP model is developed in this work based on studies described in [1], [2] & [5]. Figure 3 shows the implemented DCHP model with a speed governor and a simple cycle gas turbine. It reflects the faster response of all other conventional units than CHP in the Danish power system.

An aggregated wind farm model of a Type IV wind turbine is implemented based on the description provided in [6] & [7]. The wind turbine model, shown in Figure 4, can function both for normal operation or curtailed operation. It consists of a pitch controller, an aerodynamic model, a 2-mass mechanical model and a maximum power point tracking table (MPPT) as well

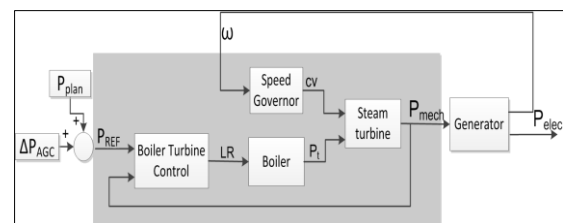

Figure 2: Aggregated CHP model – source [1] - [4]

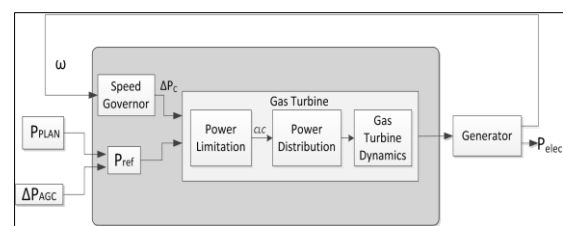

Figure 3: Aggregated DCHP model – source [1], [2] & [5]

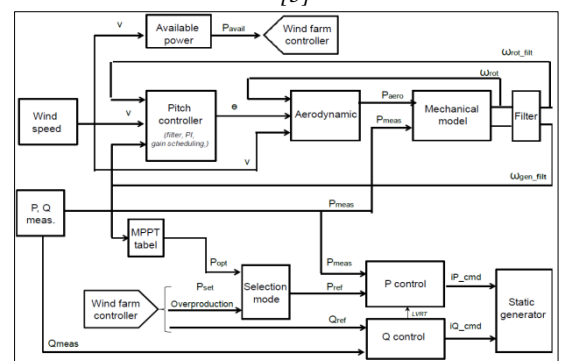

Figure 4: Aggregated Type IV wind turbine – source [6] & [7]

as an active and reactive power controller.

The power system model is developed taking into account the ramping capabilities of the generating units and the exchange power with neighboring power systems. It is worth mentioning that Denmark's neighboring power systems do not have same ramp rates for power exchange. For example, in the Nordel power system, the agreed exchange power shall be ramped within 30 minutes and shall begin 15 minutes before the agreed exchange hour. In the UCTE power system, the exchange power shall be ramped within 10 minutes and starts 5 minutes before the agreed exchange hour.

As well known, any imbalance in the active power will result in frequency deviation from its nominal level.

The speed governors of the power plants in operation sense the frequency change and releases primary reserves to stabilize the system frequency. The frequency is fully restored to its nominal level by secondary control, which is activated either manually by changing the generator power set point or automatically through an AGC. In Denmark, the secondary reserves are activated manually, apart from a load frequency controller (± 90 MW) in western Denmark with Germany border to respond to any deviations from scheduled plan. Therefore it is relevant to study AGC in this project. The implemented AGC in this work is shown in figure 5. Notice that it changes the generators active power set point depending on power imbalance in power system i.e. area control error (ACE) and their participation factors.

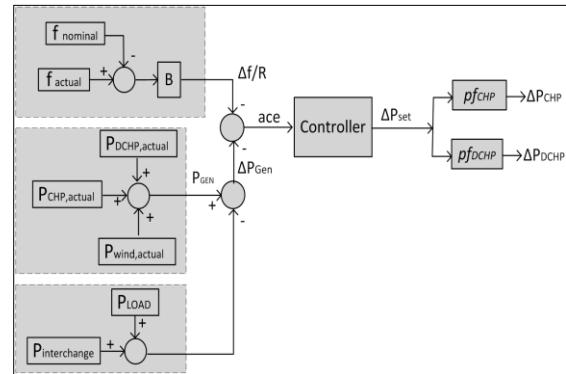

Figure 5: AGC model

iv. Simulation studies

In this section, different studies are carried out in order to illustrate the dynamic features of the implemented power system model with respect to the active power balance control. A set of simulations are performed using time series for generation, load and power exchange corresponding to one particular winter day with high wind speed. These time series are the assumptions from the Danish TSO for future power system where wind generating units have almost the same capacity as conventional generating units. On this particular day, the power generated from wind turbines and conventional units as well as the load demand in eastern and western Danish power system are shown in Figure 6 & 7, respectively. The availability of wind on this particular day allows the wind turbines to generate more power than conventional generating units.

According to [2], in Denmark, the electricity markets are balanced on hourly basis taking into account the hour ahead forecasted value of wind and load. Based on these forecasts, the generating unit's set points are decided for balancing the power system. If the actual wind power generated within the operating hour is not the same as the forecasted one, it will result in a power mismatch between generation and load. Figure 8 show the wind power deviation from its hour ahead predicted value in eastern and western Danish power system. The

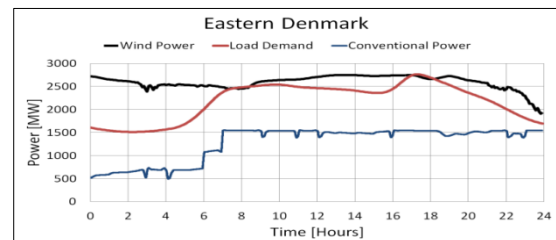

Figure 6: East Dk - Generation

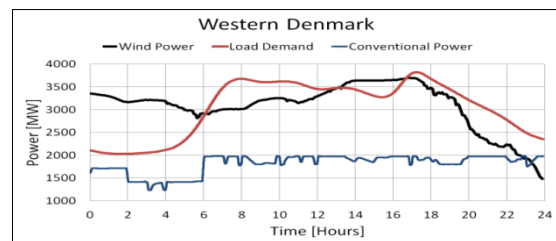

Figure 7: West Dk - Generation

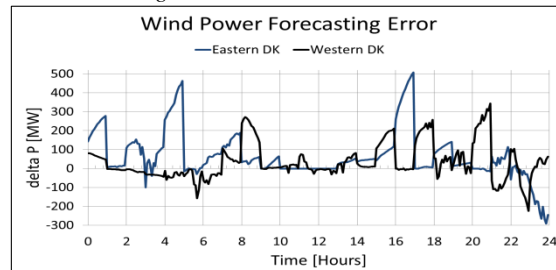

Figure 8: Wind Power forecast error

deviation in wind power is as follows:

$$P_{error}^{wind} = P_{actual}^{wind} - P_{hour\ ahead}^{wind} \quad (1)$$

The wind forecasting error creates an imbalance between generation and load, which yields to a change in the system frequency. The process is as following, the speed governors provide the initial support by releasing the primary reserves automatically. Afterwards the AGC provides new set point to the generators based on their participation factors and the ACE. The support from conventional generating units to reduce the imbalance power can be seen in Figure 6 & 7 as spikes at start of each hour and the ramp within an hour.

Figure 9 & 10 shows the power imbalance in eastern and western Denmark power system respectively, while Figure 11 & 12 shows the corresponding system frequencies in these power systems. The power imbalance in these power systems do not return to zero although the AGC changes the generators set points. The reason is that the AGC output is limited to ± 90 MW, which restricts the secondary action from providing the power equal to wind power forecast error. The huge spikes in these figures are due to the different power exchange ramp rates with neighboring power systems, as mentioned before, namely the Nordel and UCTE power systems have different ramp rates and power exchange starts at different times. This means that if the power has to be transported from one power system to another, it will end in power surplus or deficit in the Danish power system at the commencement of each hour and will result in power imbalance.

The illustrated deviation in the system frequency corresponds to the amount of power imbalance. The surplus power results in frequency rise while the deficit in frequency drop. Notice that, in spite of huge power imbalance as illustrated in the future Danish power system, the system frequency remains within the normal range i.e. 49.9 – 50.1 Hz. This is because that the Danish power system is synchronously connected to stiff and large electrical network of UCTE and Nordel. They offer enormous frequency bias, which avoids frequency abnormality in Danish power system even with large scale integration of wind power.

v. Conclusion

This paper studies the impact of large scale integration of wind power on power system operation. An adequate Danish power system model is developed to analyze the system behavior during power imbalance, where key reason for an imbalance is an inaccurate wind speed forecast. The model examines the reliability and the security of power system pertaining to power deviation from its schedule. Thus the availability of reserves, specified control strategy and interconnection with strong electrical networks decides the level of integration of wind power in any power system.

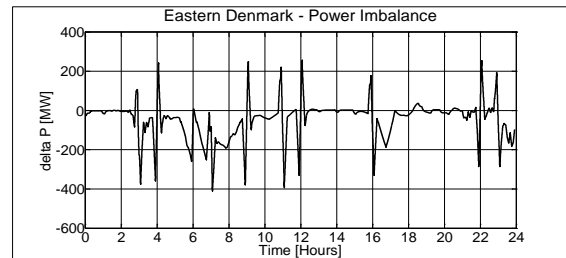

Figure 9: Imbalance power in East DK

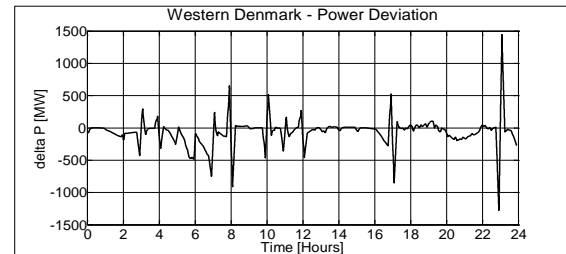

Figure 10: Imbalance power in West DK

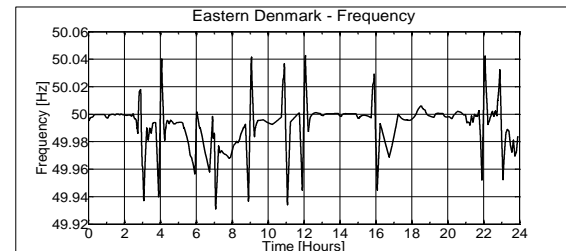

Figure 11: System frequency East DK

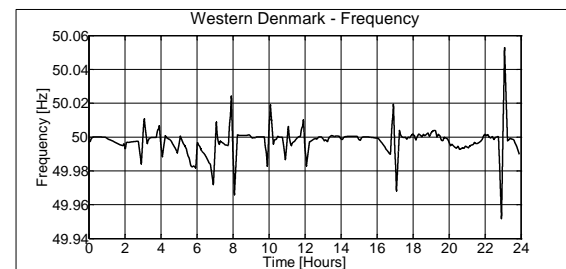

Figure 12: System frequency West DK

vi. Acknowledgement

The author would like to thank Sino-Danish center for education and research (SDC) for funding this PhD project

vii. References

- [1]: A. Suwannarat, "Integration and Control of Wind Farms in the Danish Electricity System", Phd thesis, Institute of Energy Technology, Aalborg University, 2007.
- [2]: Georgios Giannopoulos, 'Frequency control in area with large scale wind power', Master thesis, July 2012
- [3] F. De Mello, "Dynamic models for fossil fueled steam units in power system studies," IEEE Transaction on Power Systems, vol. 6, pp. 753-761, 1991.
- [4] R. Byerly, "Dynamic models for steam and hydro turbines in power system studies," IEEE Transactions on Power Apparatus and Systems, pp. 1904-1915, 1973
- [5] "CIGRE Task Force 25 of Advisory Group 02 of Study Committee C4 (Task ForceC4.02.25), "Modeling of Gas Turbines and Steam Turbines in Combined CyclePower Plants", 2003.
- [6] Hansen A.D., Margaris I. Germán C. Tarnowski, Florin Iov, 'Simplified Type 4 wind turbine modeling for future ancillary services', EWEC 2013
- [7]: Hansen A. D., Margaris I., "Type IV Wind Turbine Model", DTU wind energy, 2013

DTU Wind Energy is a department of the Technical University of Denmark with a unique integration of research, education, innovation and public/private sector consulting in the field of wind energy. Our activities develop new opportunities and technology for the global and Danish exploitation of wind energy. Research focuses on key technical-scientific fields, which are central for the development, innovation and use of wind energy and provides the basis for advanced education at the education.

We have more than 230 staff members of which approximately 60 are PhD students. Research is conducted within 9 research programmes organized into three main topics: Wind energy systems, Wind turbine technology and Basics for wind energy.

Technical University of Denmark

Department of Wind Energy

Frederiksborgvej 399

Building 118

4000 Roskilde

Denmark

Phone 46 77 50 85

info@vindenergi.dtu.dk

www.vindenergi.dtu.dk