

Technical University of Denmark



Analysis of Highly Wind Power Integrated Power System model performance during Critical Weather conditions

Basit, Abdul; Hansen, Anca Daniela; Sørensen, Poul Ejnar; Altin, Müfit

Published in:

Proceedings of the 13th International Workshop on Large-Scale Integration of Wind Power into Power Systems as well as on Transmission Networks for Offshore Wind Power

Publication date:
2014

Document Version
Publisher's PDF, also known as Version of record

[Link back to DTU Orbit](#)

Citation (APA):

Basit, A., Hansen, A. D., Sørensen, P. E., & Altin, M. (2014). Analysis of Highly Wind Power Integrated Power System model performance during Critical Weather conditions. In Proceedings of the 13th International Workshop on Large-Scale Integration of Wind Power into Power Systems as well as on Transmission Networks for Offshore Wind Power Energynautics GmbH.

DTU Library
Technical Information Center of Denmark

General rights

Copyright and moral rights for the publications made accessible in the public portal are retained by the authors and/or other copyright owners and it is a condition of accessing publications that users recognise and abide by the legal requirements associated with these rights.

- Users may download and print one copy of any publication from the public portal for the purpose of private study or research.
- You may not further distribute the material or use it for any profit-making activity or commercial gain
- You may freely distribute the URL identifying the publication in the public portal

If you believe that this document breaches copyright please contact us providing details, and we will remove access to the work immediately and investigate your claim.

Analysis of Highly Wind Power Integrated Power System model performance during Critical Weather conditions

Abdul Basit
DTU wind energy
Technical University of Denmark
Denmark
Sino-Danish Centre for Education and Research (SDC)
Denmark

Anca D. Hansen
Poul E. Sørensen
Mufit Altin
DTU wind energy
Technical University of Denmark
Denmark

Abstract – Secure power system operation of a highly wind power integrated power system is always at risk during critical weather conditions, e.g. in extreme high winds. The risk is even higher when 50% of the total electricity consumption has to be supplied by wind power, as the case for the future Danish power system in 2020. This paper analyses and compares the performance of the future Danish power system during extreme wind speeds, where wind power plants are either controlled through a traditional High Wind Shut Down storm controller or a new High Wind Extended Production storm controller. For this purpose, the power system model has been developed that represents the relevant dynamic features of power plants and compensates for power imbalances caused by the forecasting error during critical weather conditions. The regulating power plan, as an input time series for the developed power system model, is provided by the hour-ahead power balancing model, i.e. Simulation power Balancing model (SimBa). The regulating power plan is prepared from day-ahead power production plan and hour-ahead wind power forecast. The wind power (forecasts and available) are provided by the Correlated Wind power fluctuations (CorWind) model, where the wind turbine storm controllers are also implemented.

Keywords – Wind Power Plants (WPPs); Automatic Generation Control (AGC); Power balance control; High Wind Shut Down (HWSD); High Wind Extended Production (HWEP)

I. Introduction

High wind power integration influences the technical operation of a power system, particularly the active power balance control between generation and demand during extreme high wind speeds. It can result in a significant loss of wind power in very short time (minutes) [1], instigating the power imbalance in the power system. With increasing wind power integration, the situation is even more alarming for future power system, e.g. the case of Danish power system in 2020, where 50% of the total electricity production has to be supplied by wind power [2]. Therefore, while planning the power balancing operation of a large scale wind power integrated power system; the variable wind power generation must be taken in account along with the technical capabilities of the generating units.

The wind turbine is normally equipped with High Wind Shut Down (HWSD) storm controller to safeguard turbine from mechanical breakdown during extreme winds. The HWSD controller halts wind turbines from operation if wind speed increases than 25 m/s [3]. However in similar circumstances, the wind turbine equipped with the new High Wind Extended Production (HWEP) storm controller will gradually reduce their power output [3], providing a positive impact on the power system balance without effecting the turbines structural integrity. This study analyses the impact of HWSD or HWEP storm controller on active power balance control in future Western Danish power system model.

The Western Danish power system model with high wind power penetration is developed in this study, taking the generation and power exchange capacities for the year 2020 into account [4]. The implemented power system model includes models for the centralised or De-centralised Combined Heat and Power plants (CHPs or DCHPs), Wind Power Plants (WPPs), interconnections with neighbouring power system and coordinated Automatic Generation Control (AGC) system between CHPs and WPPs. The performance of the developed power system model during extreme wind conditions is assessed and discussed by means of set of simulations, where hour-ahead generation schedules in a time scale of five minutes, generated by Simulation power Balancing (SimBa) model, are used as inputs. The conventional generation and the power exchange are using hour-ahead time series, while WPPs generate the available wind power. SimBa, developed by the Danish TSO Energinet.dk together with the Technical University of Denmark, releases an hour-ahead regulating power plan based on day-ahead power production plan and hour-ahead wind power forecast [4]. The hour-ahead forecast and the available wind power are provided by the Correlated Wind power fluctuations (CorWind) model, where the wind turbine storm controllers (HWSD and HWEP) are implemented.

The article is structured as follows. A brief description of the storm controllers, i.e. HWSD and HWEPE is initially provided. Then the proposed active power balance control methodology is described, approaching also the aspects regarding the generation of the hour-ahead (HA) regulating power plan and the AGC. The extreme high wind speed scenarios for the Western Danish power system in year 2020 are used to analyse the active power balance control through a set of simulations with the developed Danish power system model. Finally, conclusive remarks are reported in the final section.

II. Storm Controller

The storm controller ceases power generation from wind turbines during critical weather conditions, to prevent turbine from damage due to extreme mechanical loads. The typical storm controller (HWSD) halts the wind turbine from operation, when wind speed reaches 25 m/s. However, the HWRD functionality enables wind turbines to operate at higher wind speeds with reduced power output, without affecting the structural integrity of the turbine. These storm controllers are briefly described below:

A. High Wind Shut-Down (HWSD)

HWSD is the typical storm controller installed in majority of the wind turbines. The HWSD controller halts the turbine operation when average wind speed reaches to a certain level. The average wind speed is based on 1 second, 30 seconds and 10 minutes. The HWSD behaviour is described by the power curve presented in Figure 1. The sudden cut off may result in active power balance/frequency control issues on power system level, depending on the wind power integration in the power system.

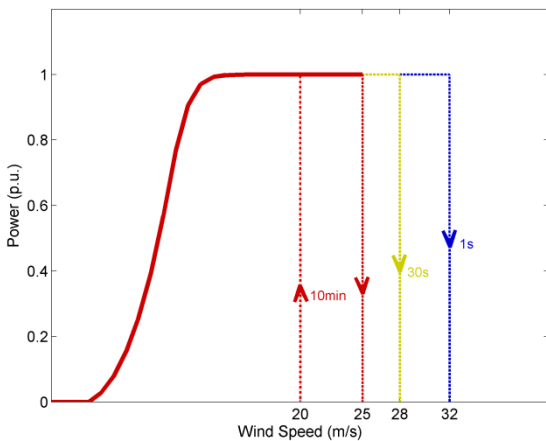

Figure 1: HWSD – wind power curve

B. High Wind Extended Production (HWEPE)

At higher wind speeds, the HWEPE allows production from wind turbine by de-rating the power and speed regularly as a function of wind speed, without impacting the structural integrity of the turbine [3]. The power curve depicting the behaviour of HWEPE controller is shown in Figure 2.

The HWEPE controls generation from wind turbine in two modes, that acts parallel and aren't directly dependent on one another [1]. First operational mode reduces the turbine rotational speed based on the rotor acceleration, by converting the current rotor speed to absolute acceleration. The acceleration value with a gain limits the turbine rotational speed proportional to the increase in wind speed and the turbulence intensity. To avoid high torque on the rotor due to reduction in speed, the power output from the wind turbine is also reduced. In second operational mode, the power output is reduced by controlling the pitch angle. The pitch angle increases as a function of wind speed increase and thus result in a gradual power reduction. Bias values for pitch and rotor acceleration are also assigned with the activation of HWEPE to allow smoother transition in power and speed, rather than a sudden step change.

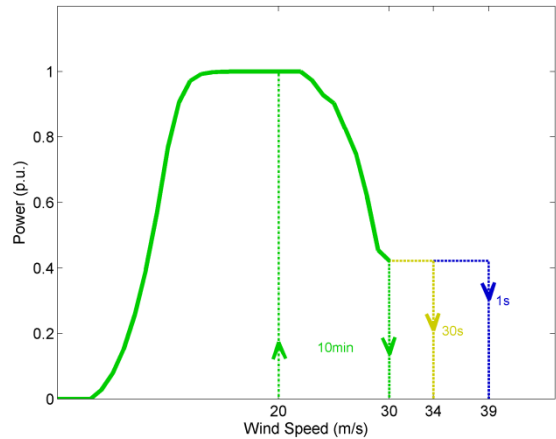

Figure 2 HWEPE – wind power curve

The wind turbine starts again to operate, when the average wind speed drops below certain value. To prevent frequent restarts and shutdowns, the turbine is connected only when the average wind speed reaches to 20 m/s, as shown in Figure 1 and Figure 2.

In this study, HWSD and HWEPE controllers were implemented in CorWind model, to analyse the dynamic behaviour of Danish power system model during high wind speeds.

III. Power balance control

TSOs securely operate the power system in maintaining the active power balance in the power system. In deregulated power systems, the balance is maintained through electricity markets by the balance responsible companies, who can produce, consume or retail. The examples of electricity markets are the day-ahead (DA), hour-ahead (HA) and regulating power markets, where dispatch bids are selected with foremost intent of preserving system integrity and to minimize the production cost. Subsequent to DA market, the HA market modifies the DA dispatch bids before the actual operation period, taking in account the updated wind power forecasts or unavailability of power plants. However in real-time operation, the wind power may be different from the HA forecast, which can lead to active power imbalance in the power system. This power imbalance is then compensated through regulating reserves in the real-time.

In this study, the real time imbalance is caused due to the forecasting error during critical weather conditions and the imbalance is compensated through automatic reserves, i.e. with AGC, when WPPs are equipped with either HWSO or HWEP storm controllers. The following subsections will explain the power balancing model with the generation of HA regulating power plan for the power plants and power exchange with neighbouring power systems and the real time power balance control in the power system with the coordinated AGC dispatch between CHPs and WPPs.

A. Hour-ahead power balance control

SimBa, the HA power balancing model, simulate the regulating power plan to ensure the active power balance control in the power system. It uses data input time series from DA market model and HA forecast of wind power to generate regulating power plan for the intra-hour balance with five minute resolution. The DA time series (P_{plan_DA}) are provided by Wind Power Integration in Liberalised Electricity Market (WILMAR), while the Correlated Wind power fluctuations (CorWind) model provides the HA forecast of wind power (P_{WPP_HA}), as shown in Figure 3. The CorWind model also provides the DA forecast of wind power (P_{WPP_DA}) and the available wind power (P_{WPP_avail}). As aforementioned, for the analysis presented in this paper, the storm controllers were implemented in CorWind model to provide P_{WPP_avail} during extreme high wind speeds.

SimBa models the power system taking into account the current grid regulations and the electricity market rules. SimBa uses inputs from WILMAR that include hourly

values for energy production, load and the power exchange between interconnected areas and HA wind power forecasts from CorWind. Based on these inputs, SimBa balances the power system and provides HA five minutes period plan for generating plants and power exchange with neighboring power systems, i.e. P_{plan_HA} .

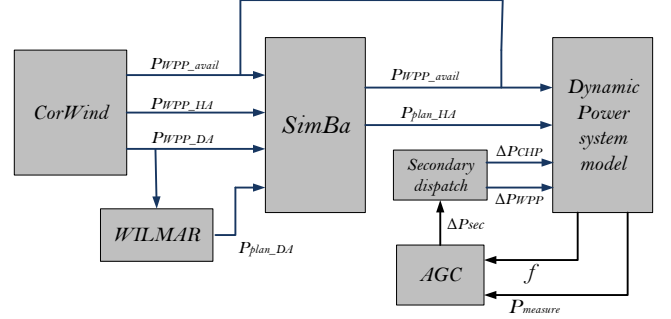

Figure 3: Overview of the signals between CorWind, WILMAR, SimBa, the power system model and the AGC.

During real-time, the power system can come out of balance, if available wind power is not the same as HA forecast. The active power balance is then controlled through activation of regulating bids from the Nordic Operational Information System (NOIS) list in the TSO's control room and also through AGC with a reserved capacity of ± 90 MW, acting on the border of Western Denmark with Germany. However, for the present investigation, it is assumed that the power imbalance is controlled only through AGC.

B. Automatic generation control (AGC)

AGC developed and implemented in this investigation is sketched in Figure 4. It measures the frequency deviation (Δf) from its nominal level and the possible power mismatch (ΔP) between generations (CHPs, DCHPs, and WPPs) and power exchange with neighbouring power systems and system load, as shown in Equation 1. The sum of ΔP with the product of Δf and system frequency bias factor (B) is called the ‘‘area control error’’. B is determined from the droop characteristics of all generating units taking part in the primary response [5]. The area control error (ΔP_{ACE}) is processed by a central controller, usually a PI, which calculates the required change in production (ΔP_{sec}) for the power plants to bring the ΔP_{ACE} to zero (Equation 2).

$$\Delta P = P_{Load} + P_{exchange} - P_G \quad (1)$$

$$P_{ACE} = \Delta P + (\Delta f \times B) \quad (2)$$

As indicated in Figure 4, the change in production ΔP_{sec} is then distributed using the ‘dispatch strategy’ block among the actively participating generators, namely CHPs and WPPs assumed in this study. The dispatch decides the

change in reference power for the participating generating units, i.e. ΔP_{CHP} and ΔP_{WPP} , by using as inputs ΔP_{sec} signal, CHPs power generation (P_{CHP}), WPPs power generation (P_{WPP}) and the available wind power ($P_{\text{WPP_avail}}$) [4].

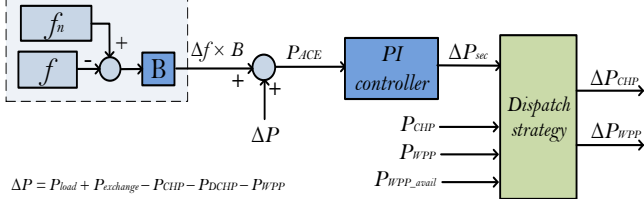

Figure 4: AGC and dispatch strategy model

The dispatch strategy decides the delta set-points for the participating generating units as follows: the WPP is down regulated only when the output of AGC is negative, i.e. $\Delta P_{\text{sec}} < 0$, while the CHP provide secondary responses for positive or negative value of ΔP_{sec} . For down regulation, the WPP will receive reference power signal only when CHP generation touches the lower generation limit or ΔP_{sec} reaches to $\Delta P_{\text{CHP_LowLim}}$, i.e. -90 MW. However, in case of up regulation, i.e. $\Delta P_{\text{sec}} > 0$, only the CHP provides the secondary support, as the WPP is already generating the available wind power.

IV. Power system model

As aforementioned, the future Western Danish power system model is used to study the power balance control during extreme high wind speeds, where generation from WPPs under these conditions are either controlled through HWSD or HWEP storm controllers. This study requires a detailed dynamic representation of the power system that includes conventional power plants, WPPs and the interconnection with neighbouring power systems. The system interconnections and the aggregated power plants models, developed in Power Factory, are explained below.

A. System interconnections

The Western Danish power system is synchronously connected to the strong CE power, via Germany, which offers huge frequency bias. The Western Denmark is also connects to the Nordel power system via HVDC link, i.e. Eastern Denmark, Norway and Sweden. However, there are plans to increase the AC interconnection capacity with Germany and HVDC interconnection capacity with Norway and also to build new HVDC link with Holland [4]. The system interconnections are modelled as simple load accompanied by an external grid, which shows the deviations on AC link in case of power imbalance. The external grid offers the frequency bias and the inertia of the synchronous power system.

B. Power plants modelling

The electrical power generation in Denmark is a combination of conventional and renewable generation sources, where conventional power generation is typically from CHPs and DCHPs and renewable generation is primary based on WPPs contribution. In this study, the aggregated models for these power plants are developed having advantage of a reduced computation effort while maintaining the dynamic features relevant for long term dynamic simulation studies. The power system model developed for this study is based on the description presented in [6 – 9]

Aggregated CHP model reflects the slow boiler response of the thermal power plant [6 – 7]. The boiler and steam turbine response of the CHP is the dominant characteristic for active power balance control in power system studies and can affect the power system stability. Correspondingly, aggregated model for DCHP considers the dynamics of gas turbine [8] and aggregated WPP model takes in account the active power response from the WPPs [9]. SimBa and the AGC provide the power set points for these power plants.

V. Simulation results

A set of simulations are performed using time series for generation, load and power exchange corresponding to a scenario with extreme high wind speeds. The time series are generated by SimBa for the future Danish power system (2020) based on the real data from the year 2009 (October 3 20:00 – October 4 12:00).

The electricity market balances the Danish power system taking in account the HA wind power forecasts. The power system comes out of balance if the available wind power generated within the operating hour differs from the HA forecast. The power imbalance yields to a change in the system frequency and deviation in power exchange from HA schedule. The power imbalance is worse if the forecasting error leads to wind turbine cut off (during storms). Figure 5 shows the real-time power generation from the WPPs during high wind speeds, when conventional storm controller (HWSD) or new storm controller (HWEP) is in operation.

During initial period, the HWSD controller ceases operation from number of wind turbine due to extreme high wind speeds, resulting in a high power imbalance from the HA balance plan, as shown in Figure 6. However, in similar circumstances, the HWEP while safeguarding the turbines structural integrity only deregulates the production from wind turbines, thereby resulting in lower forecasting error and lower power imbalance.

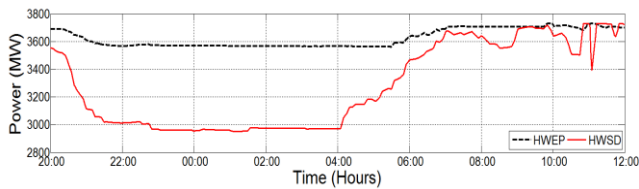

Figure 5: Wind power production – HWEP & HWSD

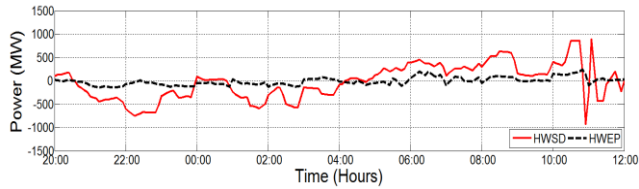

Figure 6: Power imbalance due to HA forecast error

The generating unit instantly responds to the power imbalance by releasing primary reserves. Afterwards, the AGC response reduces the power imbalance in the power system by providing new set points to the participating generating units, i.e. CHP and WPP. The decrease in the power imbalance depends on the reserves availability. The dispatch strategy block in Figure 4 determines the change in reference power set points for CHP (ΔP_{CHP}) and WPP (ΔP_{WPP}). As aforementioned, the WPP only participate in the down regulating process, while CHP contributes in both up and down regulating processes. Also, the ΔP_{WPP} is activated only when CHP are unable to provide the required response, namely that when the ΔP_{CHP} touches the lower limit (-90 MW) or they are operating at their lower generation limit (20% of the online capacity). The delay in overall secondary response will be due to the AGC response, reference power ramp rate (i.e. 30 MW/min considered in this study) and slow boiler response of CHP units, as boiler needs 5 – 6 minutes to modify its output pressure when demanded.

Figure 7 shows the secondary dispatch power for the CHP and WPP, while Figure 8 shows the residual power imbalance after secondary response, when HWSD or HWEP is in operation. During initial operation period (20:00 – 04:30), the high wind speed results in cutting off wind turbines by the HWSD controller and thus large negative power imbalance. The AGC responds to this power imbalance by regulating the reserves from the CHP; however, the power imbalance couldn't be reduced further as the dispatch is limited by +90 MW. In the same operational period, the WPPs couldn't provide any support as they are already generating the maximum possible power. In similar circumstances, the HWEP only reduces the power generation from the wind turbine and thus results in a lower power imbalance which can be compensated by AGC, as shown in Figure 7 and Figure 8.

In later period, the wind turbines again start producing the available wind power, as the average wind speed reduces consequently resulting in generation excess from the HA balance plan. The imbalance is then reduced by manoeuvring the generation from CHPs and WPPs through AGC. The imbalance is high again in case of HWSD controllers, as wind turbines previously taken out of operation starts generating the available wind power.

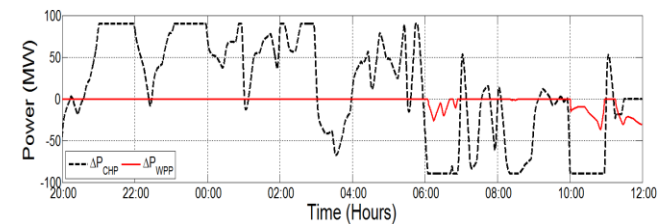
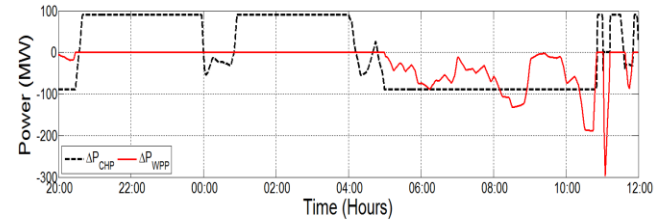

Figure 7: AGC dispatch; top:HWSD, bottom:HWSD

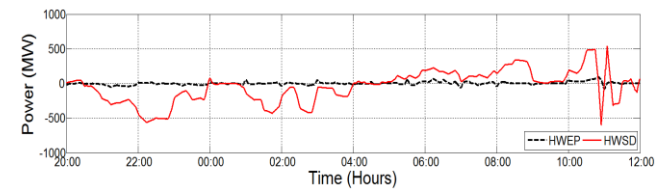

Figure 8: Power deviation after Secondary Response

VI. Conclusion

Large scale integration of wind power challenges the reliable operation of power system, especially during critical weather condition, e.g. extreme high wind speeds. If not forecasted, these conditions may result in a high power imbalance especially for the wind turbines equipped with High Wind Shut Down storm controllers. During extreme high wind speeds, the High Wind Shut Down ceases power generation from wind turbines for their mechanical safety. Analogously, the wind turbine with High Wind Extended Production will only de-rate their generation, thus safeguarding their structural integrity and resulting in less power imbalance during real-time.

This study analyses the active power balance control in future Western Danish power system during extreme high wind speeds, when WPPs are either controlled with High Wind Shut Down storm controller or High Wind Extended Production storm controller. From the results, it can be concluded that High Wind Shut Down results in high power imbalances which can't be fully compensated with primary

and secondary reserves, and therefore residual power imbalance can affect the reliable system operation. However, controlling the wind turbines with High Wind Extended Production will result in less power imbalance and thus assures safe operation of the power system during critical weather conditions.

VII. Acknowledgement

This paper is a part of PhD project funded by Sino-Danish centre for education and research (SDC).

VIII. References

- [1] Cutululis NA, Litong-Palima M, Sørensen PE, Bjerger, MH & Detlefsen, N, "Impact of High Wind Speed Shut-down in the Danish Power System," in 12th International Workshop on Large-Scale Integration of Wind Power into Power Systems as well as on Transmission Networks for Offshore Wind Power (WIW 2013), 2013.
- [2] Vittrup C, "2013 was a record-setting year for Danish wind power," Energinet.dk, 2014.
- [3] Cutululis NA, Litong-Palima M, Sørensen PE, "Offshore Wind Power Production in Critical Weather Conditions," in Proceedings of EWEA 2012 - European Wind Energy Conference & Exhibition. European Wind Energy Association (EWEA), 2012
- [4] Basit A; Hansen AD, Altin M, Sørensen P, Gamst M, "Wind power integration into the automatic generation control of power systems with Large-scale wind power," IET - JoE, 2014.
- [5] Prabha K, Power System Stability and Control, McGraw-Hill, 1994.
- [6] I.C. Report, "Dynamic Models for Steam and Hydro Turbines in Power System Studies," IEEE Transactions on Power Apparatus and Systems, Vols. PAS-92, no. 6, pp. 1904-1915, November 1973.
- [7] IEEE Committee Report, "Dynamic models for fossil fueled steam units in power system studies," IEEE Transaction on Power Systems, vol. 6, no. 2, pp. 753-761, May 1991.
- [8] CIGRE Task Force 25 of Advisory Group 02 of Study Committee C4, "Modeling of Gas Turbines and Steam Turbines in Combined Cycle Power Plants," CIGRE, 2003.
- [9] IEC 61400-27 Committee Draft, Wind Turbines Part 27-1, "Electrical simulation models for wind power generation Wind turbines," IEC Std. committee Draft (CD) 88/424/CD, 2012.