



Status and recommendadtions for RD&D on energy storage technologies in a Danish context

Pedersen, Allan Schrøder; Elmegaard, Brian; Christensen, Claus Hviid; Kjøller, Claus; Elefsen, Frank ; Hansen, John Bøgild; Hvid, Jørgen ; Alex, Sørensen Per; Kær, Søren Knudsen; Vangkilde-Pedersen, Thomas ; Feldthusen Jensen, Thorkild

Publication date:
2014

Document Version
Publisher's PDF, also known as Version of record

[Link back to DTU Orbit](#)

Citation (APA):

Pedersen, A. S. (Ed.), Elmegaard, B., Christensen, C. H., Kjøller, C., Elefsen, F., Hansen, J. B., ... Feldthusen Jensen, T. (2014). Status and recommendadtions for RD&D on energy storage technologies in a Danish context.

DTU Library

Technical Information Center of Denmark

General rights

Copyright and moral rights for the publications made accessible in the public portal are retained by the authors and/or other copyright owners and it is a condition of accessing publications that users recognise and abide by the legal requirements associated with these rights.

- Users may download and print one copy of any publication from the public portal for the purpose of private study or research.
- You may not further distribute the material or use it for any profit-making activity or commercial gain
- You may freely distribute the URL identifying the publication in the public portal

If you believe that this document breaches copyright please contact us providing details, and we will remove access to the work immediately and investigate your claim.

Status and recommendations for RD&D on energy storage technologies in a Danish context

February 2014

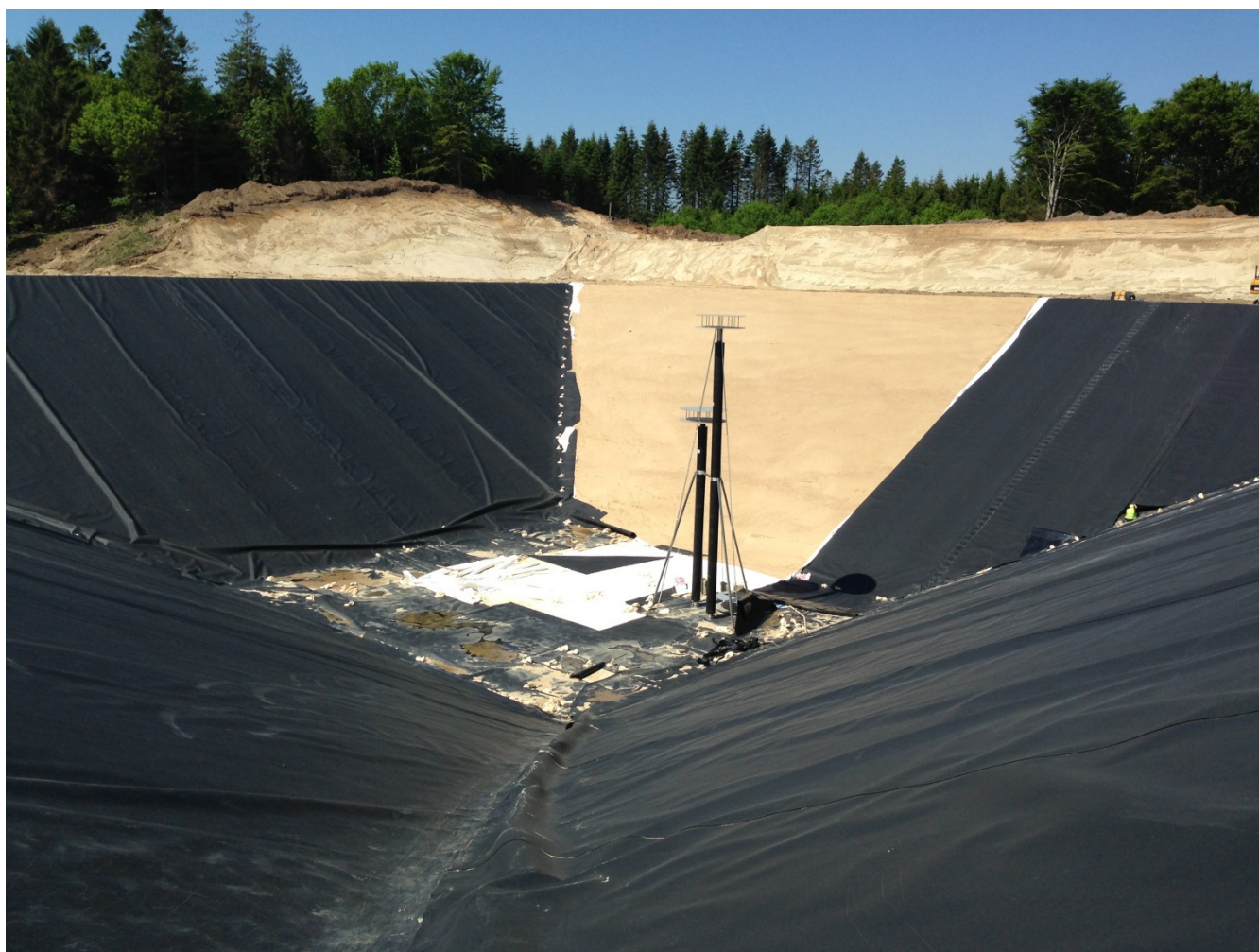

This report has been developed for the Danish energy research programmes and is published jointly by:

- the Danish Energy Authority (EUDP and Green Labs DK)
- Energinet.dk (ForskEL and ForskVE)
- the Danish Council for Strategic Research and
- the Danish Energy Association (ELFORSK).

Main authors:

Allan Schrøder Pedersen, DTU (editor)

Brian Elmegaard, DTU

Claus Hviid Christensen, DONG Energy

Claus Kjøller, GEUS

Frank Elefsen, Danish Technological Institute

John Bøggild Hansen, Haldor Topsøe A/S

Jørgen Hvid, Rambøll A/S

Per Alex Sørensen, PlanEnergi

Søren Knudsen Kær, Aalborg University,

Thomas Vangkilde-Pedersen, GEUS

Thorkild Feldthusen Jensen, Rambøll A/S

In addition, valuable input has been received and used from the project

Advisory Committee:

Aksel Mortensgaard, Partnerskabet for Brint og Brændselsceller,

Anders Bavnhøj Hansen og Jeannette Møller Jørgensen, Energinet.dk,

Bo Nørregaard Jørgensen, SDU,

Inga Sørensen, VIAUC,

Jacob Andreasen, SE,

Jan Olsen, JolTech,

Jørgen Boldt, HOFOR,

Jørgen Jensen, Green Hydrogen,

Laila Grahl-Madsen, IRD,

Lars Barkler, Lithium Balance,

Mikael Sloth, H₂Logic,

Morten Hofmeister, Dansk Fjernvarme,

Per G. Kristensen, DGC,

Per Hessellund Lauritsen, Siemens,

Rasmus Lærke, Vestas,

Stig Niemi Sørensen, ENOPSOL,

Thomas Brouer, Energi Danmark,

Torben René Jensen, AU

Table of Contents

1	Overview of acronyms in the document	5
2	English and Danish summary	10
2.1	Summary in English.....	10
2.2	Dansk resumé.....	11
3	Introduction and background.....	13
3.1	Guide to the reader.....	13
3.2	How and why the work was initiated	13
3.3	Objectives and limitations of the work.....	13
3.4	Defining and delimiting the concept of energy storage in the present work.....	14
3.5	Parallel efforts in Europe and abroad.....	14
3.6	Project group	16
3.7	Advisory Committee.....	16
4	Basic assumptions for the work.....	18
5	Where will the needs for storage/flexibility emerge in the Danish energy system.....	19
5.1	Add flexibility to the electricity and heating system.....	19
5.2	Facilitating substitution of fossil fuel by renewable energy	19
5.3	Cost minimisation	20
5.4	Application areas	21
5.4.1	Grid applications in the light of fossil generation capacity being out phased	21
5.4.2	Fuelling transport.....	21
5.4.3	Balancing heat demand and production.....	21
5.4.4	Cold storage	22
5.4.5	Time perspective for needs to emerge - central as well as local needs.....	22
5.4.6	Modelling results for storage needs to emerge in the electricity grid	23
5.4.7	Modelling results for storage needs to emerge in heat supply.....	25
6	Energy Storage in the future energy market (electricity and heat).....	26
7	Technology descriptions and recommendations	29
7.1	Chemical energy storage	29
7.1.1	Short technology description.....	29
7.1.2	Technology status in industry.....	30
7.1.3	Applications	31
7.1.4	Development needs for the technology to become market mature.....	32
7.1.5	Specific recommendations in a Danish context.....	32
7.1.6	Players in Denmark	33
7.2	Batteries	34
7.2.1	Short technology description.....	34
7.2.2	Technology status in industry.....	34

7.2.3	Applications	35
7.2.4	Development needs for the technology to become market mature.....	35
7.2.5	Specific recommendations in a Danish context	37
7.2.6	Players in Denmark	37
7.3	Thermo-mechanical energy storage.....	40
7.3.1	Short technology description.....	40
7.3.2	Technology status in industry.....	41
7.3.3	Applications	41
7.3.4	Development needs for the technology to become market mature.....	42
7.3.5	Specific recommendations in a Danish context.....	42
7.3.6	Players in Denmark	42
7.4	Thermal energy storage.....	44
7.4.1	Short technology description.....	44
7.4.2	Technology status in industry.....	46
7.4.3	Applications	48
7.4.4	Development needs for the technology to become market mature.....	49
7.4.5	Specific recommendations in a Danish context.....	51
7.4.6	Players in Denmark	53
7.5	Emerging technologies	56
8	Schematic technology comparison.....	57
9	Danish efforts and strongholds in an international perspective.....	58
10	Recommendations for national Danish efforts	60
11	Timeline	64

1 Overview of acronyms in the document

Acronym	Definition
AA	Aalborg
AAU	Aalborg University
AC	Alternating Current
ACAES	Adiabatic Compressed Air Energy Storage
AEC	Alcaline Electrolyzer Cell
ALP	Adiabatic Liquid Piston
APS	Auxillary Power Supply
ARRA	American Recovery and Reinvestment Act of 2009
ATES	Aquifer Thermal Energy Storage
AU	Aarhus University
BMS	Battery Management System
BRP	Balance Responsible Party
BTES	Borehole Thermal Energy Storage
BYG (DTU)	DTU Civil Engineering
CA	California
CAES	Compressed Air Energy Storage
CASE	Catalysis for Sustainable Energy
CEA	Commissariat à l'énergie atomique et aux énergies alternatives
CEDREN	Centre for Environmental Design of Renewable Energy (Norway)
CEESA	Coherent Energy and Environmental System Analysis (Aalborg University)
CHP	Combined Heat and Power
CO	Carbon Monoxide
COP	Coefficient of Performance
CSP	Concentrated Solar Power
CTO	Chief Technology Officer

Acronym	Definition
DC	Direct Current
DD	Development and Demonstration
DER	Distributed Energy Resources
DFM	Danish National Metrology Institute
DGC	Danish Gas Technology Centre
DK	Denmark
DKK	Danish Kroner (currency)
DME	DiMethyl Ether
DOE	Department of Energy (US)
DSF	Strategic Research in Sustainable Energy and Environment (Denmark)
DSM	Demand Side Management
DSO	Distribution System Operator
DTI	Danish Technological Institute
DTU	Technical University of Denmark
EASE	European Association for Storage of Energy
EC	European Commission
ECES	Energy Conservation through Energy Storage
ECOMOVE	e-mobility project
EERA	European Energy Research Alliance
EM	Energy Membrane
ENERGY	
ENS	Danish Energy Agency
EPRI	Electric Power Research Institute
ESS	Energy Storage System
EU	European Union
EUDP	Energy Technology Development and Demonstration

Acronym	Definition
EV	Electric Vehicle
FLECH	Flexible Clearing House
FU	Research and Development
GB	Great Britain
GEO	Danish Geotechnical Institute
GEUS	Geological Survey of Denmark and Greenland
GW	Giga Watt
HDPE	High Density PolyEthylene
HOFOR	Greater Copenhagen Utility
HP	Heat Pump
HRS	Hydrogen Refuelling Station
HT	High Temperature
HVAC	High Voltage Alternating Current
IEA	International Energy Agency
IEC	International Electrotechnical Commission
IPU	Innovation Factory IPU
ISBN	International System for Book Numbering
ISE	Institute for Solar Energy
JRC	Joint Research Center (EU)
KTH	Royal Institute of Technology (Sweden)
KU	University of Copenhagen
LDPE	Low Density PolyEthylene
LFC	Load Frequency Control
LFP	LiFePO4
LHS	Latent Heat Storage
LT	Low Temperature

Acronym	Definition
LTO	$\text{Li}_4\text{Ti}_5\text{O}_{12}$
MW	Mega Watt
NL	Netherlands
NMC	Nickel-manganese-cobalt
NREL	National Renewable Energy Laboratory (US)
ORC	Organic Rankine Cycle
PCM	Phase Change Materials
PEM	Polymer Electrolyte Membrane or Proton Exchange Membrane
PEMFC	Proton Exchange Membrane Fuel Cell
PEX	Cross-linked polyethylene
PGM	Platinum Group Metals
PHS	Pumped Hydro Storage
PTES	Pit Thermal Energy Storage
PV	Photovoltaic
RD	Research and Development
RE	Renewable Energy
REACH	Regulation for Registration, Evaluation, Authorisation and Restriction of Chemicals
RES	Renewable Energy System
RHC	Renewable Heating and Cooling
SDU	University of Southern Denmark
SET	Strategic Energy Technology
SHS	Sensible Heat Storage
SMES	Superconducting Magnetic Energy Storage
SNG	Synthetic Natural Gas
SOEC	Solid Oxide Electrolyzer Cell

Acronym	Definition
SOFC	Solid Oxide Fuel Cell
SPE	Solid Polymer Electrolyte
TCM	Thermo-Chemical Materials
TCS	Thermo-Chemical Storage
TES	Thermal Energy Storage
TSO	Transmission System Operator
UK	United Kingdom
UPHS	Underground Pumped Hydroelectric Storage
UPS	Uninterrupted Power Supply
UTES	Underground Thermal Energy Storage
VEKS	Heat and Power Company of Western Copenhagen
VIA	VIA University College
VIAUC	VIA University College
WP	Work Package

2 English and Danish summary

2.1 Summary in English

The present report has been prepared by a project group composed of representatives from Danish industry and Danish research community. It makes recommendations about future Danish efforts within public support for RD&D on energy storage technologies in a Danish perspective.

The report defines energy storage as:

- *Man-made (artificial) storage of energy in physical or chemical form for utilisation at a later time.*

The report briefly describes analyses of the future need for energy storage in a Danish perspective and assesses which sectors of the energy system, where energy storage can be expected to play a role and what kind of services it could provide to give flexibility in the sustainable energy system.

The work has been based on an assessment of the technical needs for energy storage in the future Danish energy system towards 2030 and further on. In particular, the report does not present new information or data on future economic performance of storage technologies. Within the given timeframes and resources for the work, it has also not been possible to provide an exhaustive catalogue or comprehensive descriptions of energy storage technologies.

A number of assumptions are underlying the work in the report. The most important ones are the central Danish political goals that:

- 50% of electricity supply should come from wind power in 2020
- All domestic electricity and heat demand should be supplied by non-fossil sources in 2035
- By 2050 Denmark should be completely independent of fossil energy

In addition, we have assumed that biomass and interconnecting transmission lines will not be sufficient to provide required flexibility in the electricity system and at the same time provide suitable and sufficient energy for transport.

The recommendations in the report take rise in a number of criteria, the most important being:

- the technologies' relevance in the future Danish energy system
- Danish strongholds and competences (research and industry) within storage technologies
- assessment of market potentials – national as well as international

Technologies not specifically described in the report are estimated to not be of sufficient relevance and potential to justify a concerted action in the Danish RD&D support programmes. However, the report also underlines that the recommendations given in the report should not be adopted rigidly, but rather as overall guidelines, which naturally should be deviated from should the occasion arise.

The following main topics are recommended for support in the Danish RD&D programmes during the coming decade and the report makes detailed, specific technical recommendations for each technology:

Chemical Energy Storage

The technologies of storing energy in the form of chemical compounds (carbon- or non-carbon-containing chemical fuels) hold a considerable potential to meet many challenges associated with storing energy in the future energy system. In addition, Denmark has strong RD&D groupings covering a wide spectrum of electricity to fuel conversion technologies.

Batteries

Batteries have attractive storage properties in terms of high power rates and infinitesimal reaction time in response to altering voltage over the electrodes. Batteries thus have important and highly demanded services to offer in the future Danish energy system.

Thermal energy storage

Linking different energy sectors will become an appreciated asset of the future energy system and thermal energy storage is likely to play a central role on this scene, linking electricity to heating and cooling. Denmark has an extensive district heating system, where heat storage fits excellently, and in addition, heat storage is crucial in efforts to improve energy efficiency.

Furthermore, the report calls for attention to certain types of mechanical energy storage technologies and finally it suggests encouraging system analyses including possibilities for energy storage.

A timeline for energy storage to become a commercial component in the Danish energy system is given tentatively.

2.2 Dansk resumé

Nærværende rapport er udarbejdet af en projektgruppe med repræsentanter fra dansk industri og dansk forskning. Rapporten giver anbefalinger til en kommende indsats indenfor forskning, udvikling og demonstration af energilagringsteknologier i et dansk perspektiv.

I rapporten nævnes den definition af energilagring, som er lagt til grund for arbejdet, nemlig:

- Kunstig lagring af energi i fysisk eller kemisk form til brug på senere tidspunkt

Rapporten beskriver kort analyser af det fremtidige behov for energilagring i et dansk perspektiv og giver vurderinger af, i hvilke dele af energisystemet energilagring kan forventes at spille en rolle og hvilke typer af ydelser lagret energi kan forventes at medføre med hensyn til fleksibilitet i det vedvarende energisystem.

Arbejdet har fokuseret på de tekniske behov for energilagring i det fremtidige danske energisystem frem mod 2030 og til dels videre. Det bemærkes således at rapporten ikke giver ny viden eller data vedrørende fremtidig økonomi i forbindelse med brug af energilagring. På samme måde har det heller ikke - indenfor de givne tids- og ressourcemæssige rammer – været muligt at give et udtømmende katalog eller komplette beskrivelser af lagringsteknologier.

Til grund for arbejdet har ligget en række forudsætninger, hvoraf de vigtigste er de danske politiske målsætninger om:

- 50% af elforbruget skal dækkes af vindenergi i 2020
- Forbrug af el og varme skal dækkes af ikke-fossile ressourcer i 2035

- Danmark skal være uafhængig af fossile energikilder i 2050

Det er yderligere forudsat at biomasse og el-forbindelser til udlandet ikke vil være tilstrækkeligt til at sikre den fornødne fleksibilitet i el-systemet og samtidig tilvejebringe tilstrækkeligt brændstof til den danske transportsektor.

Anbefalingerne i rapporten tager udgangspunkt i en række kriterier, hvoraf de mest væsentlige er:

- Teknologiernes relevans i det fremtidige danske energisystem
- Danske styrkepositioner og kompetencer (industri såvel som forskning og udvikling) indenfor lagringsteknologierne
- Vurderinger af markedspotentiale – nationalt og internationalt

Lagringsteknologier, som ikke nævnes specifikt i rapporten vurderes til ikke at have tilstrækkelig relevans og potentiale til at begrunde en struktureret støtteindsats fra de danske FU&D programmer. Det er dog vigtigt at understrege, at anbefalingerne i denne rapport ikke bør antages rigtigt, men derimod som nogle overordnede retningslinjer, som bør fraviges efter nærmere vurdering i påkommende tilfælde.

Følgende hovedområder udpeges i rapporten som anbefalelsesværdige indenfor det kommende tiår og rapporten giver for hvert enkelt område nærmere, detaljerede tekniske anbefalinger:

Lagring af energi i kemiske forbindelser

Teknologierne til lagring af kemisk energi i form af kemiske forbindelser – kulstofholdige eller ikke-kulstofholdige kemiske brændsler – har et betydeligt potentiale til at løse næsten alle tekniske behov for energilagring i det fremtidige danske energisystem. Danmark har desuden en række stærke FU&D grupperinger som dækker et bredt spektrum af el-til-brændstof teknologier

Batterier

Batterier har attraktive lagringsegenskaber med hensyn til f.eks. effekt og responstid overfor ændrede spændinger over elektroderne. Batterier vil uden tvivl spille en betydelig rolle i det fremtidige danske energisystem og der er i Danmark et stigende industrielt og forskningsmæssigt engagement i avanceret batterier og batteristyring.

Termisk energilagring

At binde forskellige sektorer af energisystemet (f.eks. el og varme) sammen vil blive stærkt medvirkende til at skabe fleksibilitet og frihedsgrader i det fremtidige energisystem og termisk energilagring - i form af lagring af varme eller kulde – er en vigtig teknisk forudsætning for at nå væsentlige mål på dette punkt ligesom termisk energilagring har afgørende betydning for forbedring af energieffektivitet i husholdninger og industri.

Rapporten opfordrer yderligere til opmærksomhed på visse typer af mekaniske energilagringsteknologier og endelig peges i rapporten på at energisystemstudier vil være væsentlige for opdaterede fremtidige vurderinger af behov for energilagring.

Rapporten giver slutteligt en tentativ tidshorisont for hvornår energilagring kan forventes at være en komponent i energisystemet på kommercielle betingelser.

3 Introduction and background

3.1 Guide to the reader

Asking technical experts to describe their darling technology and how it should be treated is really asking for trouble. Specialists will try to inform the readers loyally, but also comprehensively and exhaustively and do not want to leave any bit of information behind.

When preparing the present report we faced exactly this situation and in consequence hereof – to oblige the reader - we have divided the report into a number of sections, each characterised by different levels of details.

Firstly, in sections 2-5, we present a general discussion of the future needs for storage with special outset in the development of the Danish energy system as set by broadly accepted political goals in Denmark.

Secondly, in sections 6.1-6.5 we give fairly accessible descriptions of and RD&D recommendations for the technologies we find most relevant for development in a Danish context. These descriptions are relatively easy to understand for individuals, who are not necessarily familiar with the technology fields in question. **In Section 7**, we present a coarse, schematic comparison of relevant key properties of energy storage technologies.

Thirdly, in sections 8-9, we give a very condensed description of our reasoning and recommendations found in the report. We want to underline that these sections should not be the reader's only take away from the report, but merely a quick reminder of the main points.

In Annex A, we present the full technology descriptions and details for recommendations.

In Annex B, we present available SET Plan targets for many of the discussed technologies to give the reader a reference with respect to present technology status and future targets in terms of technical and economic performance.

In Annex C, we present tables and figures from external sources giving performance data and economic data for energy storage technologies.

3.2 How and why the work was initiated

The public Danish RD&D programmes have identified energy storage as one of three priority areas for reaching the energy political goals of green energy transition towards 2050 (the other areas are Smart Grid and energy efficiency in buildings).

In support of a focused Danish RD&D effort within energy storage, the funding programme committees need a status of relevant energy storage technologies and an evaluation of their potentials in a Danish context as well as an overview of Danish players on the scene of energy storage. Such results – collected in a report – should be of internal use within the secretariats and should also be published to the benefit of potential, future applicants for funding.

3.3 Objectives and limitations of the work

The work has aimed to:

- Map Danish strongholds within types of energy storage technologies which are or may become relevant in Denmark. The mapping should include all sectors of the Danish energy system including electricity, heating and cooling, gas and transport.
- Take a starting point in existing plans for development of the Danish energy system with particular focus on the period 2020-2030.
- Result in a set of recommendations for how public support to RD&D could be optimally invested in the period towards 2020.
- Classify storage technologies according to their technology readiness level.
- Describe relevant energy storage technologies based on their development potential and time perspective as well as applicability in a Danish context.
- Identify Danish competences and players within energy storage, covering research and innovation as well as commercial companies.
- Describe Danish potentials within energy storage in an international perspective.

The work has been based on existing knowledge among the project group members and from information available in open literature, see also references provided in the document. Within the given time and economy framework, it has not been possible to generate new independent knowledge, nor to prepare exhaustive descriptions or catalogues of energy storage technologies. In particular, the project group has refrained from giving economic assessments of the future performance of the described technologies. However, in Annex B, the SET Plan targets for the technologies are given (where available), including data on economic performance.

3.4 Defining and delimiting the concept of energy storage in the present work

Energy storage can be defined in a number of ways; some of which might be called 'virtual energy storage'. However, in the present report, we have used the following definition of energy storage:

- *Man-made (artificial) storage of energy in physical or chemical form for utilisation at a later time*

The following definitions are not included in the work:

- Natural production of biomass is not included in the concept of energy storage even though sun power is indeed stored during production of biomass.
- A fossil-fuelled power plant on stand-by is not included, even though in some respects it provides the same service as an energy storage facility.
- Time-shifting of electricity demand (sometimes called 'virtual energy storage') is not included, although time-shifting solves the same kind of problems as energy storage.

3.5 Parallel efforts in Europe and abroad

Recently, a comprehensive report has been published (Joint EASE/EERA recommendations for a European Energy Storage Technology Development Roadmap towards 2030, 2013). The work was initiated by the European Commission and as indicated by the title, it was prepared in collaboration between the European Association for Storage of Energy (EASE) and the Joint Programme on Energy Storage under the European Energy Research Alliance (EERA). The report

gives an exhaustive description of potentials, development needs and recommendations for actions in a European perspective.

IEA is currently working on an Energy Storage Road Map, which has not yet been published, but planned to be finalised by the end of 2014.

Furthermore, many countries have tried to assess their own national future needs for energy storage. Emphasis has been put on needs in the electricity grids, which is where most workers foresee the first needs to arise. Characteristically, the resulting reports envisage energy storage to become important to the energy system, but only very few reports try to address the need for energy storage in quantitative terms and in particular, they do not take potential interactions between different sectors of the energy system, eg heating/cooling, electricity and gas, into account. Likewise, most reports do not address the question of energy storage for fuelling transport.

The following national or regional reports concerning future needs for energy storage have been compiled and form part of the background information behind the present work:

EPRI:

- Electricity Energy Storage Technology Options. A White Paper Primer on Applications, Costs, and Benefits. EPRI1020676.

Germany:

- Andreas Palzer and Hans Martin Henning. A future German energy system with a dominating contribution from renewable energies: a holistic model based on hourly simulation. 2013. Energy Technology

Scotland:

- 2020 Route map for Renewable Energy in Scotland. The Scottish Government, Edinburgh 2011. ISBN: 978-1-78045-271-5 (web only).

UK:

- The future role for energy storage in the UK Main Report, June 2011 Energy Research Partnership Technology Report, ENERGY RESEARCH PARTNERSHIP, 8 PRINCES GATE, EXHIBITION ROAD, LONDON SW7 2PG,

USA:

- The Role of Energy Storage with Renewable Electricity Generation, Paul Denholm, Erik Ela, Brendan Kirby, and Michael Milligan (Technical Report, NREL/TP-6A2-47187. January 2010)
- Energy Storage for the Electricity Grid: Benefits and Market Potential Assessment Guide, Jim Eyer and Garth Corey (SANDIA REPORT, SAND2010-0815, Unlimited Release, Printed February 2010)

JRC – EC

- Assessing Storage Value in Electricity Markets. A. ZUCKER, T.HINCHLIFFE and A. SPISTO. JRC Scientific Report 2013. ISBN 978-92-79-32362-1 (pdf)

Denmark:

- Overview of current status and future development scenarios of the electricity system in Denmark – allowing integration of large quantities of wind power. P.Sorknæs, H.Maeng, T.Weiss and A.Andersen, Report (Delivery 5.1) in the EU store Project, http://www.store-project.eu/en_GB/target-country-results

- Energi 2050, Vindspor.
<http://energinet.dk/SiteCollectionDocuments/Danske%20dokumenter/EI/Energi%202050%20Vindsporet%203.pdf>
- CEESA reports, <http://www.ceesa.plan.aau.dk/Publications/work+package+reports/>
- Varmelagringsteknologier
(http://www.danskfjernvarme.dk/Faneblade/GronEnergi/Arrangementer/Afsluttede%20arrangementer/~/_media/GronEnergi/Analyser/Udredning%20vedrørende%20varmelagringsteknologier%20og%20store%20varmepumper%20til%20brug%20i%20fjernvarmesystemet.ashx)
- [Comparative analyses of seven technologies to facilitate the integration of fluctuating renewable energy sources.](#) / Mathiesen, Brian Vad; Lund, Henrik. IET Renewable Power Generation, Vol. 3, Nr. 2, 06.2009, s. 190-204.
- [The role of large-scale heat pumps for short term integration of renewable energy.](#) / Mathiesen, Brian Vad; Blarke, Morten; Hansen, Kenneth; Connolly, David.

3.6 Project group

A project group was established September 2013 and has the following members:

- Claus Hviid Christensen, R&D Director, DONG Energy
- Søren Knudsen Kær, Professor, Aalborg University,
- Thomas Vangkilde-Pedersen, Head of Department, GEUS
- Frank Elefsen, Teknologichef, CTO, Danish Technological Institute
- John Bøgild Hansen, Senior Scientist, Haldor Topsøe A/S
- Thorkild Feldthusen Jensen, Senior Director, Environment, Rambøll A/S
- Per Alex Sørensen, Head of Department, PlanEnergi
- Allan Schrøder Pedersen, Section Head, DTU Energy Conversion (project management)

3.7 Advisory Committee

In addition to the project group itself, an Advisory Committee was established in October consisting of the following members:

- Aksel Mortensgaard, Partnerskabet for Brint og Brændselsceller
- Anders Bavnhøj Hansen, Energinet.dk
- Bo Nørregaard Jørgensen, SDU
- Inga Sørensen, VIAUC
- Jacob Andreasen, SE
- Jan Olsen, JolTech
- Jørgen Boldt, HOFOR
- Jørgen Jensen, Green Hydrogen
- Laila Grahl-Madsen, IRD
- Lars Barkler, Lithium Balance
- Mikael Sloth, H2Logic
- Morten Hofmeister, Dansk Fjernvarme
- Per G. Kristensen, DGC

- Per Hessellund Lauritsen, Siemens
- Rasmus Lærke, Vestas,
- Stig Niemi Sørensen, ENOPSOL
- Thomas Brouer, Energi Danmark
- Torben René Jensen, AU

By October 2013, the Advisory Board had received information about the first meeting in the project group and the planned structure of the final report. On 9 January 2014, a physical meeting was arranged between the Advisory Board and the Project Group at Danish Technological Institute in Aarhus. The meeting was attended by 25 delegates (including the project group) and many valuable comments and discussions were raised based on the draft final report distributed in advance. After the meeting, detailed comments and suggestions were received from members of the Advisory Committee in written form. The project group has aimed to include all comments to the best of its ability.

4 Basic assumptions for the work

To evaluate the needs and potentials for energy storage technologies in Denmark over the next decades, the following basic assumptions have been made:

- 50% of electricity supply should come from wind power in 2020
- In 2035, all domestic electricity and heat demand should be supplied by non-fossil sources
- By 2050, Denmark will be completely independent of fossil energy.

In addition, solar power as well as solar thermal energy is assumed to provide perceptible inputs to the energy system in a way which precisely calls for energy storage (eg seasonal and daily storage of solar energy).

In our work, we have also assumed that interconnections (electricity transmission lines connecting Denmark with neighbouring countries) as well as - even extensive - use of smart grid and demand-side management will not be sufficient to secure stability of energy supply within Denmark. The role of these technologies will be partly determined by economic arguments and partly by arguments of self-supply and supply security. However, neither interconnections nor demand side management can provide fuel for transportation. Transportation currently accounts for about one third of the total Danish final energy demand (similarly to other developed countries) and as we approach complete fossil independence, this energy must be provided by biomass in combination with electricity from wind, wave or solar power.

Biomass is a valuable energy resource which is able to provide fuel for transportation as well as flexibility in the electricity system. In our work, we have assumed that domestic biomass resources will be insufficient to secure complete stability of the future electricity system.

Within the period in question, we have assumed that wave-generated energy will not yield significant input to the Danish energy supply.

5 Where will the needs for storage/flexibility emerge in the Danish energy system

5.1 Add flexibility to the electricity and heating system

During the coming decades, the Danish energy system will be increasingly dominated by primary supply from renewable sources, as decided by the Danish Parliament. However, wind and solar power are inherently variable and cannot be dispatched like the conventional, fossil energy sources which have formed the basic energy supply in Denmark for more than a century. The uncontrollable renewable sources will inevitably bring substantial problems concerning balancing of supply and demand.

100% renewable energy may cause large mismatches: sometimes too much power will be available and at other times, there will be serious shortages. Meeting the renewable energy targets requires moving part of the generation to other time periods, and energy storage is perfectly suited to provide this service to the system.

Energy storage is still a rather expensive solution to the described problems, but this is likely to change as future developments reduce costs of technologies, while at the same time focus on grid stability makes the costs easier to justify. Storage also brings a very wide spectrum of benefits to the complete electricity system, and in addition, these benefits are currently not fully monetised.

Flexible conventional backup power plants fit excellently with fluctuating renewables, but they can only fill gaps in power supply. They cannot solve the problem of oversupply, and they still emit unwanted CO₂ if powered by fossil fuels.

Demand-side management (DSM) is sometimes the first approach to cope with variable renewables. DSM has already been used in the past to manage consumption by large electricity consumers. However, new types of DSM are being developed to also suit private households. Examples of the latter include time-resolved consumer prices, which vary with market price, and the ability of households with their own PV generation to adjust their consumption depending on how much power they are producing. Although DSM is thought of as a way to match power demand with generation, a system that converts electricity to heat can also be used to absorb cheap wind power, which might otherwise not be allowed generated. With the addition of heat storage, the same system can then reduce power demand at times of low wind production.

Today, the Danish TSO gives very high priority to improved electricity transmission (interconnections the neighbouring countries) and distribution capacity, and the Danish DSOs are interested as well. Extensions to the distribution system go along with the trend towards decentralised supply structures, while investments in transmission grids aid long-distance transport of fluctuating renewable power to balance supply and demand.

5.2 Facilitating substitution of fossil fuel by renewable energy

In the same way energy storage can add flexibility to the electricity and heating systems, it can also support and facilitate the politically aimed substitution of fossil fuels by renewable energy. As mentioned earlier, storage capability is an inherent property of fossil energy sources which has been utilised intensively in the fossil age. The same capabilities will be required in the future sustainable, fossil-free energy system and other technologies will have to provide those services. Energy storage technologies may do this job and thus facilitate the aimed transition from fossil to renewable energy sources.

5.3 Cost minimisation

When estimating economic benefits from active components in the energy system, it is important to take a holistic view on the entire system. Installing energy storage in one part of the system may well have impacts on other totally different parts of the same system. As an example, installing a modern electrical storage heater, controlled by the grid frequency and price signals, in a household will have an (infinitesimal) impact on the TSO's need to secure balancing ancillary capacity. Less regulating capacity will be required, leading to savings in system operating expenses. Such details have been evaluated thoroughly by Zucker et al.¹

Although prices for renewable energy from wind and solar technology are expected to decrease dramatically over the coming decades (the development has already been seen and is expected to continue in agreement with recognised learning curves, see figure below), they are still considerably more expensive than use of conventional power systems, as illustrated by the need for public support to achieve market penetration. Energy storage can play an important role in minimising overall costs, for instance by improving the utilisation degree of the installations. Currently wind turbines are sometimes stopped (or electricity prices go below zero) because too much power is produced (more than demand) in such periods. Admitted, those periods are short and not very frequent, but as we install still more fluctuating power generation capacity, the problem is likely to grow and take place more often. During those periods, wind turbine owners do not make money; whereas if storing the energy was a possibility, the owners could still make money and thus improve their business case and at the same time lower the total costs of the energy system.

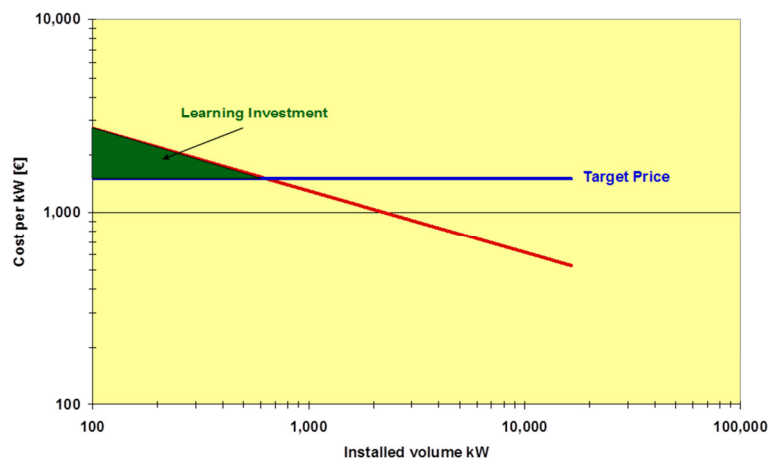

Indicative learning curve for price development of technologies²

Another example of cost minimisation implied by energy storage has been demonstrated by Strbac. In a recent work³ he demonstrates, using the UK as an example, how energy storage can eliminate or defer the need for investments in grid capacity (distribution as well as transmission) and also improve the return of investments in new, sustainable energy generation.

¹ Assessing Storage Value in Electricity Markets. A. ZUCKER, T.HINCHLIFFE and A. SPISTO. JRC Scientific Report 2013. ISBN 978-92-79-32362-1 (pdf)

² Bøgild Hansen, Springers Energy Encyclopedia

³ Strategic Assessment of the Role and Value of Energy Storage Systems in the UK Low Carbon Energy Future, Goran Strbac, Marko Aunedi, Danny Pudjianto, Predrag Djapic, Fei Teng, Alexander Sturt, Dejvices Jackravut, Robert Sansom, Vladimir Yufit, Nigel Brandon, Energy Futures Lab, Imperial College, London, June 2012

5.4 Application areas

5.4.1 Grid applications in the light of fossil generation capacity being out phased

At the moment, much of the balancing capacity needed to stabilise the Danish grid in short terms comes from conventional thermal power plants burning fossil fuels. As these are decommissioned, the ancillary services they now supply (eg frequency and voltage control) will not be available for grid stabilisation to the extent we have been used to.

Energy storage is an option in tackling these issues, and in fact a recent publication⁴ concluded that the delivery of ancillary services is likely to become the first commercial application for new energy storage technologies. Denmark's existing grid architecture was historically constructed for one-way supply of electricity from central generators to decentralised users. Such a system reaches its limits with high levels of renewables because most small renewable generators connect at medium (below 72 kV) or low (below 1 kV) voltages, right down to 220–240 V in the case of household PV. As the distribution grid reaches its limits, short-term, fast-reacting storage devices like batteries will help consumers maximise the fraction of their PV generation that they are able to use locally. With storage times typically up to 4 hours, such systems will allow distribution grids to operate autonomously for part of the time. This application of energy storage is already beginning to find commercial application but economy is still uncertain.

5.4.2 Fuelling transport

Transport consumes about one third of total final energy demand in Denmark and the energy for transport is supplied almost exclusively from fossil sources (this is true also for other developed countries). By 2050, Denmark aims to be completely independent of fossil fuels, which means that energy for transport also must be supplied from renewable sources. These sources generate electricity which subsequently must be stored in a form suitable for mobile applications, meaning high energy density (volumetric as well as gravimetric), high safety and zero or low emissions (noise, particles and harmful chemicals).

Looking at battery electric vehicles, the development in terms of number of cars in Denmark has been somewhat disappointing in so far as until now, only few vehicles have actually been sold in Denmark – in particular to private customers. It is still uncertain which role battery electrical vehicles will assume in the area of light transport (light passenger transport) in the future, but there is little doubt that for heavy duty road transport, marine transport and aviation, today's battery technologies are insufficient and some other storage technology must be developed and/or applied – conceivably alongside batteries. Synthetic, chemical fuels – carbon-containing or non-carbon-containing – seem to be attractive for this purpose because society is highly familiar with these kinds of fuel and because of their high energy density (see table) and finally because an infrastructure already exists for fossil-based fuels and may be used also for new types of similar fuels.

5.4.3 Balancing heat demand and production

As for the case of electricity demand and production, also heat demand and production will not match in the future renewable energy system.

Heat demand varies in a relatively stable manner and if supplied by non-controllable renewable generation, a need for storing heat will arise. As an example, heat from solar thermal plants is

⁴ Joint EASE/EERA recommendations for a European Energy Storage Technology Development Roadmap towards 2030. European Association for Storage of Energy, Brussels March 2013.

mainly generated in those months, where heat demand is small or largely absent. This fact prompts for large-scale seasonal heat storage from summer months to winter time.

However, the expected increased use of heat pumps will also call for heat storage, although often for shorter time periods. For instance, a heavy winter storm may – via heat pumps - generate much more heat than can be absorbed on the retail market. This heat could be stored in relatively large heat storing facilities in geological reservoirs for use in periods without wind.

A special aspect of heat demand and production in the future energy system is linked to industry using heat in processing and to the expected use of new energy conversion technologies like reversible fuel cells. The heat involved in generating electricity from fuel cells (exothermic process) may be stored and reused in the endothermic reversed process (electrolysis) and thereby improving overall efficiency considerably. The same idea can be applied to many industrial processes involving use of heat.

5.4.4 Cold storage

Cold storage is in principle equivalent to heat storage: two systems are brought out of thermal equilibrium. Thus where low temperatures are desired, for instance in food industry, cold storage can be used the same way as heat storage and provide the same kind of services to the overall energy system.

There are two types of cold storage:

1. Lowering the temperature in the stored products in a cold storage facility by running the refrigeration system for prolonged period
2. Dedicated production of ice or cold water stored in a vessel, pit or in geological reservoirs

The effect of varying temperatures on the quality of different types of stored products must be investigated to estimate the potential for the use of cold store facilities as storage in the energy system.

Ice banks have been widely used, but as refrigeration systems became more and more efficient, also at part load operation and continuous operation at full load became more and more common, they became less common. With the new demands for flexibility in the energy system they may experience a revival. However, the ice production must be efficient to minimise energy losses. Traditional ice production includes rather large temperature differences (cooling system temperatures of -10 °C or lower for freezing of water at 0 °C are common practice). The combination of water as refrigerant and ice as cold store media can result in very effective systems for ice production and storage, especially when utilising direct contact heat exchanger can be developed. Research and development is needed in the field of ice generation based on pure water, charging and discharging the ice storage and measurement of the stored amount of ice.

Water vapour has large potentials as an environmentally friendly refrigerant and is used in several projects aiming at commercialisation in the near future. For instance, a water chiller system with water as the refrigerant will be installed at Lego in 2015.

5.4.5 Time perspective for needs to emerge - central as well as local needs

The time perspectives for energy storage to become mandatory are difficult to predict and basically requires acceptance of scenarios. In principle, it is possible to manage an electricity system based on renewables without any energy storage included, provided there is access to very strong transmission capacity and extensive use of demand-side management. However, this situation is not desirable considering comfort and convenience; furthermore, fuelling the transport sector will indeed, as described above, require use of energy storage.

Several attempts have been made to predict when energy storage will become an inevitable requirement. Relative to total generation, 40-50% of fluctuating renewable energy is sometimes considered the limit that can be handled in a conventional electricity system⁵ without dedicated storage capacity. Denmark currently obtains about 30% of electricity demand from wind energy, whereas solar power is still only 1-2%. Thus Denmark is approaching the limit mentioned above and will reach 50% in 2020 according to existing plans. However, Denmark has good electrical connections to its neighbour countries and they are currently being expanded (expansions under construction as well as being planned). Furthermore, Denmark is utilising renewable fuels from waste and biomass, which form a dispatchable, flexible and renewable input to the electricity system and which will postpone the point where the Danish electricity system cannot be operated without energy storage services.

Norway, as one of the Danish neighbour countries, has a special capability to balance Denmark's fluctuating power generation. Norway is fully electricity supplied by renewable hydropower, which can be controlled in the sense that the water flow can be stopped and water can be stored in huge (currently 20) reservoirs able to hold about 85TWh⁶. This capacity can even be expanded and CEDREN estimates that in 2030, the potential Norwegian power storage capacity of 20 GW could be possible. At the moment, Denmark is the main customer for these services, but the future interconnections between Norway and the Netherlands, as well as Germany and the UK, will intensify the competition for the Norwegian storage services and thus this opportunity may well become less attractive in the future than it is right now. Furthermore, the Norwegian hydropower production is somewhat dependent on annual rainfall in Scandinavia (as reflected by NordPool electricity prices) and thus Norwegian hydropower may in some years not be completely stable.

In any case, the frequency and duration of periods requiring special measures to stabilise the Danish grid depend to a considerable extent on local grid quality (for example, tolerance to voltage variations, reactive power compensation needs and short-circuit capability) and the strength of connections to neighbour regions as mentioned above.

The authors of the present document are convinced that over the next 10-20 years, energy storage is very likely to become an integral part of the Danish energy system, for both short-term time shifting (energy arbitrage) and seasonal storage use. A good example of the latter is thermal energy storage: heat collected in the summer is stored for use during the winter, which is already seen at a pilot-scale basis.

5.4.6 Modelling results for storage needs to emerge in the electricity grid

Modelling future need for energy storage requires knowledge about all major aspects of the energy system in question and in particular, since actually **flexibility** rather than storage is demanded, knowledge about other means 'competing' with storage (see also Section 4.1.) is important. Basically, a full scenario will be required comprising at least:

- generation mix and capacities
- generation profiles for non-flexible generation capacity
- interconnection capacities and market data for involved neighbour regions
- consumption profile including demand-side management
- demand for the transport sector

Setting up scenarios like that includes estimations and even guesses.

⁵

⁶ CEDREN

One approach for modelling the need for flexibility in the future European electricity grid has been done by two groups at Siemens and Aarhus University. The two groups have used an average European electricity demand profile over an 8 years period and they have used weather data for the entire Europe (resolved in cells of 50x50 km²) in connection with the EU 2020 national targets for installed solar and wind power. The group at Aarhus University arrives at a storage capacity need in the range of 10-15% of total annual energy consumption⁷, depending on amount of additional balancing capacity (as provided for instance by biomass and demand-side management). It is a severe weakness of the works that they do not include exchange of energy between the electricity sector and the heating and transport sectors

In the CEESA project, it was found⁸ that the transport sector needs to be integrated into the energy system with more than 40-45% wind power, because heat pumps etc. alone are not able to ensure the balance. Electrical vehicles and flexible demand should be included, but will not suffice after 2030 when 60% electricity stems from wind and PV, so CEESA includes steam electrolyzers as well as co-electrolyzers coupled with biomass gasifiers.

In another approach focusing on the need for storage in 'Electrical West Denmark', EMD International and Helmut-Schmidt University calculated⁹ the need for energy storage in an 80% renewable electricity share scenario to 442 GWh for unlimited transmission capacity to Germany and 600 GWh for the case of no transmission capacity to Germany, even taking the heating sector into account. The numbers correspond to about 2% of the total annual electricity consumption in West Denmark.

The Danish TSO, Energinet.dk, has performed a number of energy system analyses in an effort to identify the quantitative needs for storage capacity in Denmark and balancing capability by 2035 and beyond. Notable results of the TSO analyses (Energi 2050, Vindspor¹⁰) are that an **efficient integration of the electricity, gas, heating and transport sectors** as well as improved integration with electricity markets abroad and development of Smart Grid systems will be strongly required. For one scenario, a maximum gas storage capacity is calculated to less than 4 TWh, which can be compared with the existing gas storage capacity of 11 TWh (Ll. Thorup and Stenlille). In the analyses, the projected storage capacity (giving flexibility) was calculated for electric vehicles, heat pumps and gas storage and as it appears from the below figure, the storage capacity of gas (in already existing facilities) far exceeds the others in the analysed scenario.

⁷ Storage and balancing synergies in a fully or highly renewable pan-European power system, M. G. Rasmussen et al., Energy Policy, Vol. 15, December 2012, Pages 642–651

⁸ CEESA report, <http://www.ceesa.plan.aau.dk/Publications/work+package+reports/>

⁹ Overview of current status and future development scenarios of the electricity system in Denmark – allowing integration of large quantities of wind power. P.Sorknæs, H.Maeng, T.Weiss and A.Andersen, Report (Delivery 5.1) in the EU store Project, http://www.store-project.eu/en_GB/target-country-results.

¹⁰ <http://energinet.dk/SiteCollectionDocuments/Danske%20dokumenter/EI/Energi%202050%20Vindsporet%203.pdf>

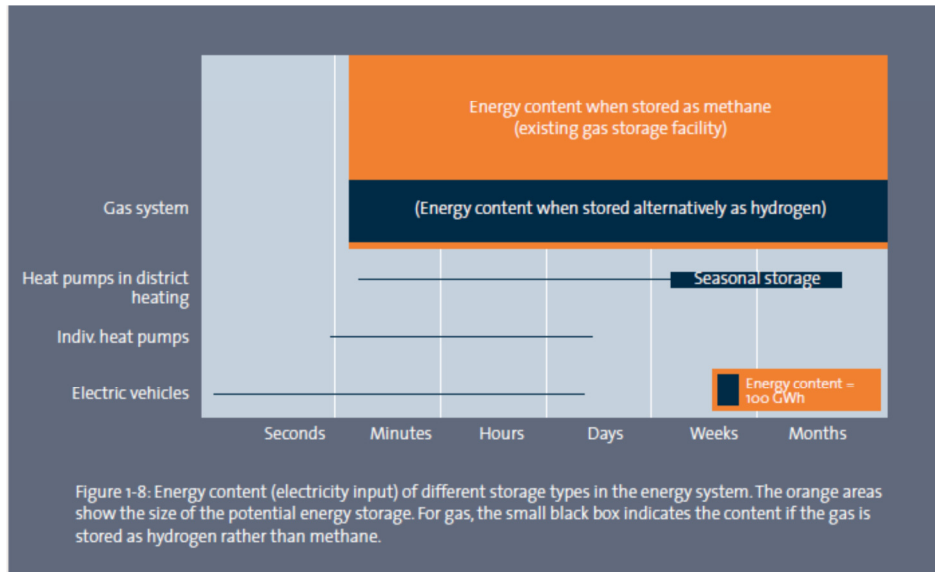

5.4.7 Modelling results for storage needs to emerge in heat supply

The need for heat storage for EU27 is calculated in a study for development of district heating in Europe¹¹. The heat storage capacity is used for storing excess heat from industries, incineration plants and renewable energy sources, eg solar thermal. The expected required capacity is 750 GWh in 2050 for an energy system with 80% CO₂ reduction compared to 1990.

In a recent German study¹², the total German energy system is optimised based on hourly simulations for a situation where electricity supply from renewable sources increases to more than 80% of supply. The required capacity of large thermal storage is calculated to 884 GWh or 300 water-based storage plants of 50.000 m³ each.

A similar Danish study¹³ calculates the demand for long-term heat storage to be 90 GWh for an energy system with 100% RES in 2050. The calculations will normally underestimate the storage demand because the heating systems are not divided in the calculations as they are in reality and this fact can have notable impact on results.

¹¹ Heat Roadmap Europe 2050. Second pre-study for the EU27. Euroheat & Power, May 2013

¹² Palzer and Henning 2013

¹³ CEESA report, <http://www.ceesa.plan.aau.dk/Publications/work+package+reports/>

6 Energy Storage in the future energy market (electricity and heat)

Energy storage will be needed in the future due to a high amount of fluctuating energy production from renewables, eg wind and PV. All kinds of energy storage technologies will result in waste of energy, hence energy conversion and storage technologies have to be optimised and well-integrated to minimise losses.

Different types of energy storage technologies can provide electrical and thermal flexibility in the future energy system and in this way become an asset for the commercial market operators. There are at least two ongoing projects in Denmark that look at what the future market for flexibility will look like. In iPower, the FLECH (Flexible Clearing House) platform is developed and in TotalFlex, a similar or slightly different flexibility market place is developed. Both platforms focus on electrical flexibility and thus only thermal flexibility indirectly through different kinds of energy conversion technologies.

A short introduction to the TotalFlex¹⁴ market place for flexibility:

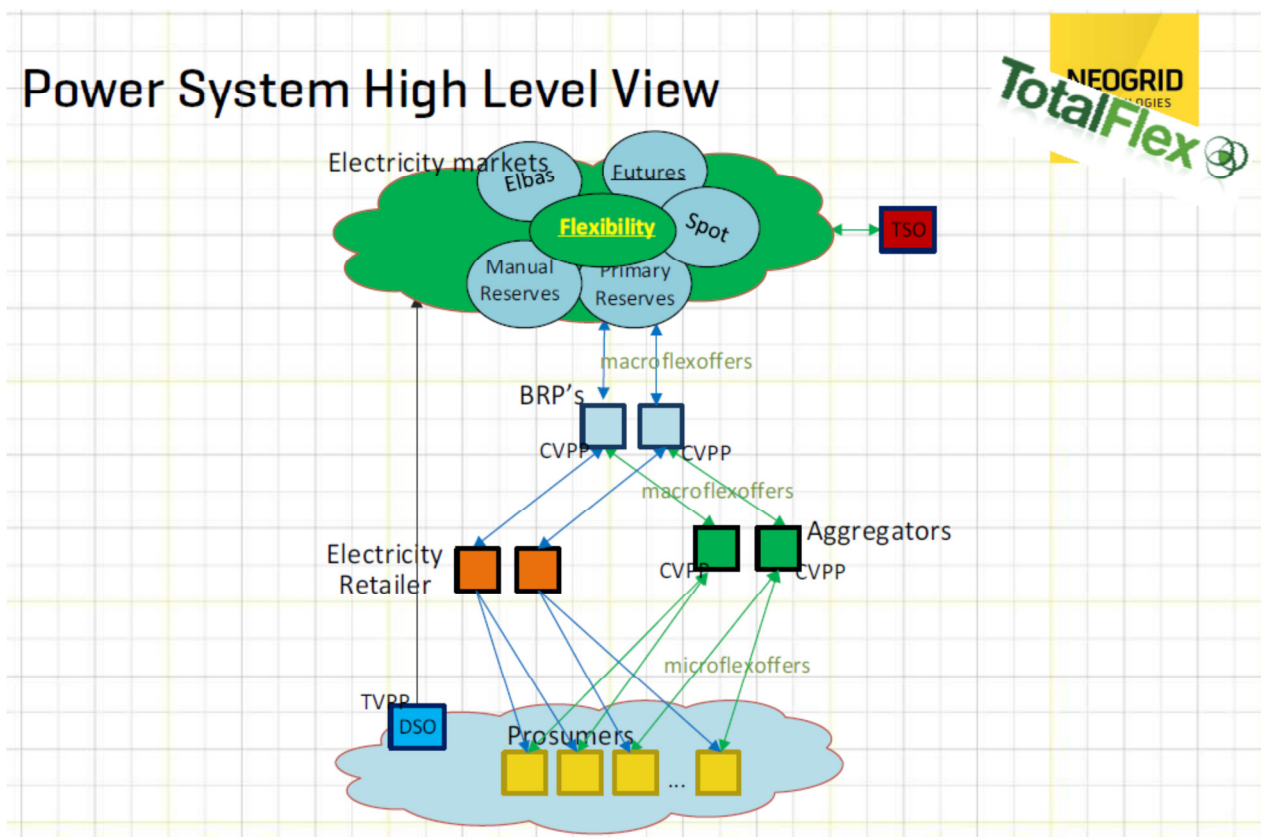

Prosumers are energy consuming and producing end-users and correspond to households, office buildings and industries. Prosumers can also provide energy storage services. These players are able to send their energy service (consumption, production and storage) flexibility (micro flex-offer) to the aggregators and receive the assignment of their service times.

The aggregators are capable of joining several micro flex-offers into larger macro flex-offers which are then placed on the electricity market place for flexibility. It also takes care of disaggregating

¹⁴ <http://www.totalflex.dk/In%20English/>

macro flex-offer responses from the electricity market. The aggregator might be an integrated part of the balance responsible party (BRP). The BRP secures the balance in the grid, ie consumption must be equal to production. The BRP makes a forecast on this for its domain. The distributed energy resources (DER) delivering the flexibility via an aggregator must also be covered by a BRP. The BRP uses a commercial virtual power plant (CVPP) to control the pool of DERs.

FLECH (FLExibility ClearingHouse)

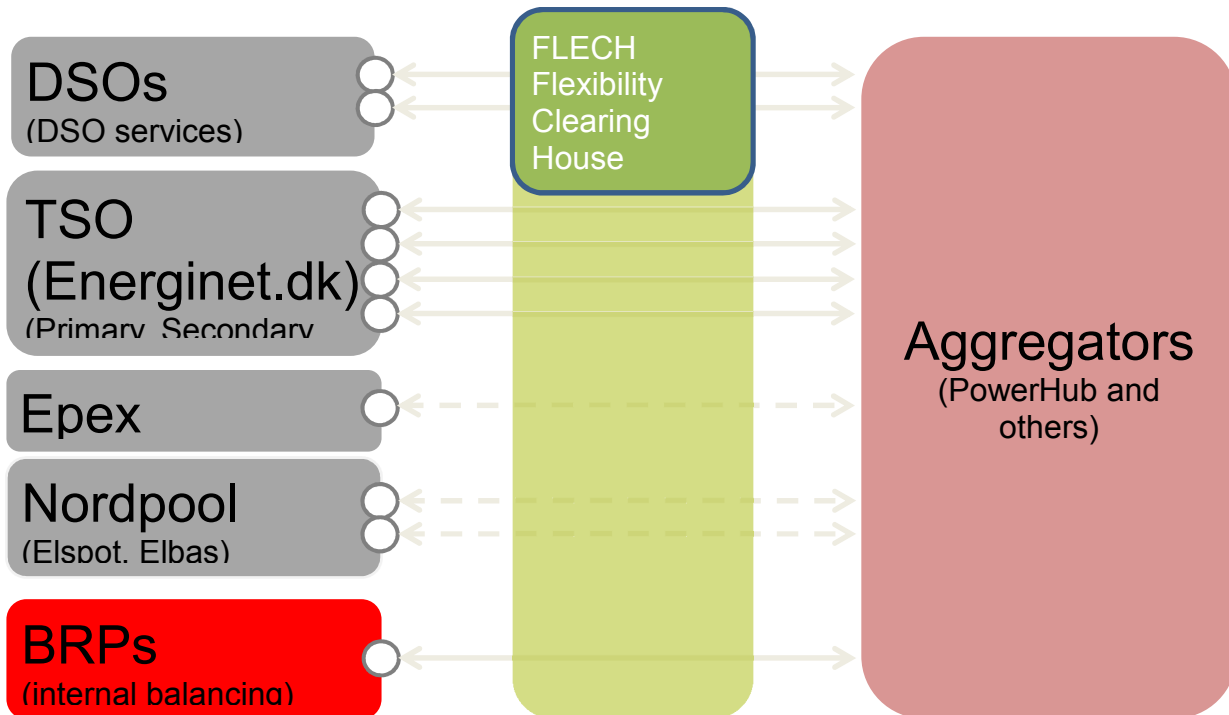

FLECH¹⁵ is a market-oriented platform developed in iPower for trading ancillary services between DSO and aggregated DER. The purpose is to establish a technical requirement specification for FLECH functionality concerning DSO ancillary services to be implemented in a prototype FLECH implementation.

The FLECH platform prototype aims at addressing following issues:

- Enable DSO to substitute grid reinforcement by utilising the flexibility present in DERs
- Activation of DSO services can cause imbalance for BRP
- BRP can deliver services to the TSO which potentially can conflict with the services needed by DSO

These market places for flexibility mainly focus on virtual storage principles, eg buildings (minutes to hours of storage capacity), district heating systems (hours to days of storage) and gas grids (seasonal storage).

¹⁵ <http://www.ipower-net.dk/>

In this future flexibility market place, physical energy storage technologies can only be a valuable asset for the market operators, if they can compete with the alternatives, eg demand response, curtailment of renewables, interconnectors, activation of conventional power plants etc. In the assessment of the different energy storage technologies, it is consequently very essential to take the market/fiscal value of the technology into account.

Market regulation

Danish authorities have not yet issued any regulating mechanisms governing use of energy storage in the energy sector – neither within electricity nor within heat storage. This is particularly relevant from an economic and taxation point of view in terms of grid fees, taxes and similar. The authors of the present report agree with the recommendations given in the 'Joint EASE/EERA recommendations for a European Energy Storage Technology Development Roadmap towards 2030'¹⁶:

- A legal framework for energy storage should be developed at EU level and allow grasping all the added value energy storage can deliver, bearing in mind that the completion of the European single market for energy is crucial. A leeway for national approaches should be incorporated, as long as they do not create market distortion.
- Current levy structures (grid fees, taxes or similar) should not hinder or discriminate the integration of energy storage.
- Storage devices can render services to the regulated and non-regulated part of the energy system. In providing such services, **market-based solutions should be preferred whenever possible** (grid safety, however, must always take precedence; storage systems are still to be fully integrated into the arsenal of regulatory tools available to system operators).
- Energy storage gives an added value on different levels in the energy system. Therefore, the operator of such devices may differ, as long as this does not trigger market distortion.
- Potential future capacity markets/payments must be shaped in such a way that without discrimination every energy storage technology should be eligible to participate, if able to fulfil the requirements.
- Specific storage technologies provide capabilities in sector export (eg power to gas, electric and fuel cell vehicles, heat storage). Given the important consequences for the markets involved, we remind you that an integrated approach is advisable.

¹⁶Joint EASE/EERA recommendations for a European Energy Storage Technology Development Roadmap towards 2030, EASE and EERA, Brussels March 2013.

7 Technology descriptions and recommendations

7.1 Chemical energy storage

7.1.1 Short technology description

In this report, chemical storage means conversion of electrical energy into chemical energy stored in chemical bonds. More advanced concepts like direct use of sunlight for chemical conversion are omitted as they seem to be in a very early stage of development. The technology considered uses electrolysis of water (and CO₂) to generate hydrogen (and carbon monoxide).

The future Danish energy systems as envisioned by Energinet.dk shows the energy value chain from production to consumption, also focusing at storage. The illustration in Figure 1 below shows hydrogen generated by alkaline-, PEM- or SOEC electrolyzers. For SOEC a synthesis gas, as a mixture of hydrogen, CO and CO₂ also may be generated.

Figure 1

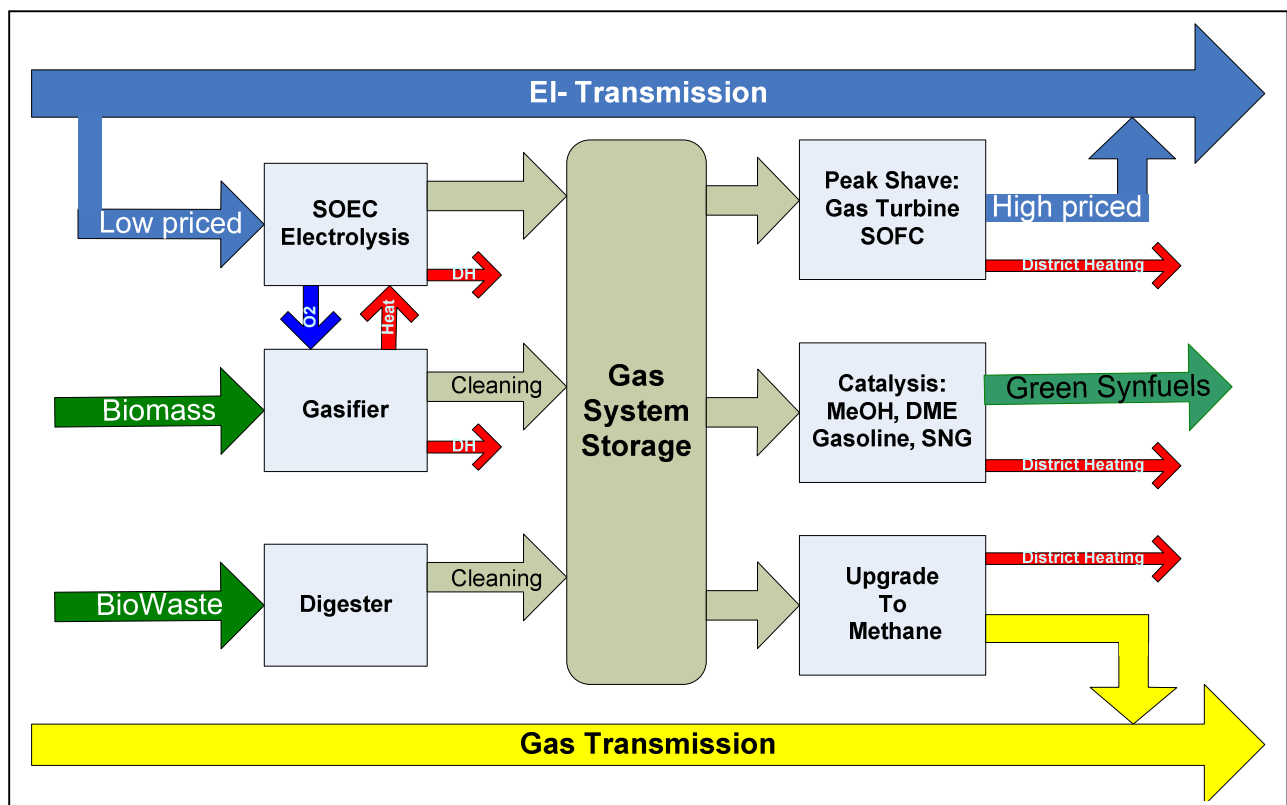

Hydrogen can be used directly for energy storage or as transportation fuel. If CO₂ is available, it can be converted with hydrogen or used in an SOEC to generate synthesis gas. In both cases, this opens up for the production of different synthetic and renewable fuels.

The direct electrochemical hydrogenation of CO₂ (or N₂) into fuels such as methane, methanol (or ammonia), higher alcohols and chemicals holds great potential, eg using renewable electricity at ambient conditions. The technology is, however, currently less developed and more fundamental research is needed to develop more efficient electrocatalysts.

All of the conversion steps to carbon containing fuels are exothermic, eg involves generation of reaction heat, which can be used for district heating. In the case of SOEC, the waste heat can be used to generate the steam used for hydrogen production. In that case, the overall conversion

efficiency from electricity to fuels is enhanced considerably as electrical power is not used to evaporate water.

Prefeasibility studies¹⁷ have shown that exergetic conversion efficiencies up to 80% can be achieved, if power electronic losses are ignored.

Both Danish and German analyses have shown that chemical storage is the only viable route to store/utilise massive amounts of intermittent renewable power. Furthermore, this option enables reuse of existing energy infrastructure in the form of the gas grid/liquid fuel distribution channels/engines etc. There is also an interesting coupling to fuel cell technology if re-electrification is desired.

7.1.2 Technology status in industry

At present, there are no commercial producers of electrolyzers in Denmark, but the research community in Denmark is at the leading edge of electrolysis research on the following three electrolysis technologies:

- Alkaline electrolysis is presently being developed primarily by at GreenHydrogen.dk and Siemens A/S, DTU Energy Conversion, and Centre for Energy Technologies AU Herning. GreenHydrogen.dk is developing alkaline electrolyzers and is approaching commercialisation of their first product. Currently, demonstration activities are ongoing for electrolyzers in the 10-40 kW range within power back-up systems for telecommunications and for Hydrogen Refuelling Station. GreenHydrogen is working to scale its kW technology into MW scale plants together with Siemens, DTU and Aarhus University. GreenHydrogen's MW scale technology is expected to be demonstrated for the first time in 2015-16. H2 Logic A/S is active on development of hydrogen refuelling stations with onsite production that could provide decentralised storage and balancing solutions. Furthermore, H2 Logic is involved in project activities (HyFillFast, coordinated by Aarhus University) about development of new technologies for hydrogen compression and combined solid state and high pressure hydrogen gas storage for mobile applications.
- In Denmark, PEM electrolysis is primarily developed at IRD A/S and DTU Energy Conversion. IRD A/S has developed a PEM stack capable of producing 1 Nm³ H₂ per h with a direct output hydrogen pressure of 100 bar. IRD is presently testing a prototype system.
- SOEC electrolysis: SOEC electrolysis developed primarily at Haldor Topsoe A/S and Topsoe Fuel Cell A/S in collaboration with DTU Energy Conversion. DTU Energy Conversion has been a pioneer within SOEC research and is world leader within co-electrolysis and pressurisation of SOEC stacks. Topsoe Fuel Cell A/S is also participating in EU sponsored projects on SOEC and is now delivering stacks to Haldor Topsøe A/S, which has initiated development work on SOEC systems. A 40-50 kW biogas upgrading plant is under construction sponsored by EUDP, which together with Energinet.dk also has funded other SOEC projects. The Topsoe group is the only group worldwide, which has both Solid Oxide Cells, catalyst and technology for synthesis gas conversion within the same company.

The production of renewable, synthetic fuels by means of catalytic conversion technology is an important element of chemical storage.

HaldorTopsøe is world leader in supply of catalyst and technology for synthetic fuel production.

¹⁷ J.B. Hansen et.al.: ECS Transactions **57** (1) 3089-3097 (2013). The Electrochemical Society

Danish Universities and consultancy companies have established a solid foundation for simulation and optimisation of sustainable energy systems. Among others, Energinet.dk has supported an ongoing project named 'MegaBalance' aiming to analyse the potential for using a large-scale network of hydrogen refuelling stations with local storage for balancing and storage of renewable electricity.

What are lacking in the complete value chain in a Danish context are dedicated power electronics, cost efficient water purification and large scale system integrators (including manufacturing of high pressure equipment). The important coupling to biomass gasification also needs a stronger Danish commitment. Opportunities exist within the area of system control for fluctuating operation.

In connection with the German 'Energiewende', a substantial amount of analysis work has been carried out sponsored by the German ministries. This has spurred more than 12 so-called P2G plants (Power to Gas) being in operation, under construction or in planning. The largest is a 6.3 MW biogas upgrading plant for Audi. Most of the plants use alkaline technology, but one company, Sunfire, is developing SOEC P2G as well as power-to-liquid technology in collaboration with the German Research Institutions. This work is heavily funded by the German state. Within PEM technology, a plant containing the world's largest single mega-watt PEM stack is expected to be delivered in the spring of 2014 to E.On in Hamburg¹⁸.

In the UK, substantial interest also exists, so far only for hydrogen production including injection into the natural gas grid. A major player is here ITM Power using PEM technology.

In France, the efforts which thus far mainly are led by CEA, are intensifying both focusing on nuclear power as well as renewables. A demo unit coupled to solar power is in operation in Corsica.

In Italy, SOFC Power has participated in one EU project together with Spanish and German partner as well as TOFC.

7.1.3 Applications

Chemical storage can be integrated in many ways in the future energy system. Intermittent electricity production can be converted into transportation fuels like hydrogen, methane, methanol, DME, gasoline or diesel. These fuels can also be used for central or decentralised CHP production or for high-temperature process heat in industry.

In the CEESA project¹⁹, the preferred, realistic 2050 scenario called for 8 TWh used for steam electrolysis combined with 10 TWh synthesis gas, producing 17 TWh transport fuel and 21 TWh used for coelectrolysis of CO₂ and steam producing 13 TWh. This can be compared with the 8 TWh used directly for electrical vehicles.

Conversion of electricity into methane would integrate the electricity and gas grid. Likewise, a potential, widespread network of hydrogen refuelling stations with onsite electrolysis hydrogen production and local storage could provide a decentralised storage and balancing solution.

¹⁸ <http://www.hydrogenics.com/about-the-company/news-updates/2013/08/29/e.on-and-swissgas-begin-commercial-operations-at-power-to-gas-facility-in-germany-using-hydrogenics-technology>

¹⁹ <http://www.ceesa.plan.aau.dk/Publications/work+package+reports/>

Although the conversion processes involved in chemical storage are rather efficient, there are also opportunities to use the waste heat for district heating purposes, which would increase the overall conversion efficiency even further.

7.1.4 Development needed in order for the technology to become market mature

For AEC it is essential to increase the energy conversion efficiency and load following performance. Corrosion and durability issues when increasing the operating temperature are important. Demonstration of suitability for 0-100% dynamic load operation within seconds and cold start and overload capabilities will be important.

For PEM systems, the R&D focus is on cost reduction, improving performance (efficiency), increasing the robustness, and increasing the hydrogen pressure.

For SOEC, the main issue remains degradation rates and robustness. Pressurised operation will be highly beneficial both from an efficiency and cost point of view. It will also be essential, if reversible operation (operating the same system both in electrolysis and fuel cell mode) is considered for re-electrification.

An important feature of the technology is the ability to extend the biomass potential by a factor of 2-3. This is because biomass (CH₂O roughly) is deficient in hydrogen compared to desired high density fuels like methane or methanol.

The coupling to biomass conversion, being biogas upgrading or biomass gasification should thus merit attention. This could also provide for use of the oxygen generated in the electrolysis processes.

If the convenience of carbon-based fuels and the related existing infrastructure is to be enjoyed in the future, the scarce resource could in fact be CO₂. The use of closed cycles with SOEC/SOFC/gas turbines with oxygen combustion plants could provide a solution.

Simulations of the total energy system providing input for varying load tests on developed equipment are essential. Technology for large-scale storage of hydrogen, oxygen and/or CO₂ is also important enabling elements.

Efficient power electronics development should likewise be given priority.

7.1.5 Specific recommendations in a Danish context

It is necessary to maintain and furthermore expand the R&DD activities within the electrolysis field, if this key enabling technology is to play the foreseen role in the politically desired future energy scenarios.

At present, the Denmark holds a leading position, but competition in Europe and further abroad is expected to intensify considerably.

There is a need for continued research ranging from fundamental materials research, identifying degradation mechanisms, next generation electrodes, electrolytes and stacking solutions to demonstration units in a sufficient scale to bridge the gap from laboratory to commercial deployment in as few steps as possible. Such demonstrations should be carefully timed and sized as they by nature are quite expensive but unavoidable, in order to realise the solutions. The funding of such demonstration units may require a concerted effort on behalf of the different

players and funding mechanisms in play today. The demonstration should take place within different applications, eg synthetic fuel production, methanisation and hydrogen fuel.

Denmark has a unique opportunity to deploy and commercialise the chemical storage technology due to the ambitious energy policy with respect to renewable electricity generation, district heating and natural gas infrastructure, its biogas potential and synergies with other untapped biomass resources.

7.1.6 **Players in Denmark**

AAU

AU

Danish Power Systems

DTU

FORCE Technology

GreenHydrogen.dk

Haldor Topsøe A/S

H2 Logic A/S

IRD Fuel Cells A/S

SDU

See also additional information in Appendix A, (A1.8)

7.2 Batteries

7.2.1 Short technology description

A battery is a number of interconnected electrochemical cells; each of which consists of two separated electrodes and an electrolyte. The electrodes are made of different materials causing an electrical potential between them. This potential is maintained since the electrolyte does not allow electronic conduction. When an external electric load is connected to the electrodes, electrons will flow from one electrode to the other through the external load, and at the same time, ions are flowing from one electrode to the other inside the battery cell to keep the electrical balance in the cell.

Batteries are practically divided in two groups: Primary battery cells are not rechargeable whereas secondary cells can be recharged and hence used for electricity storage. Apart from that, battery cells can be characterised by their nominal voltage and their capacity. The cell voltage is low (a few volts) but by connecting several cells in series, the single voltages are summed and in this way the battery pack voltage can be tailored and reach several hundred volts if desired. In the same way, battery cells connected in parallel will add up the capacity.

Batteries are basically DC devices, whereas nearly all power generators (except solar power and fuel cells) generate alternating current (AC). Therefore, mains current must be transformed to a suitable voltage and rectified before applied to a battery. Inversely, if the battery is used to power an AC application, the DC current from the battery must be transformed by an inverter. Both transformations results in some degree of energy loss.

A battery basically stores energy in the form of chemical energy, and battery cells can be based on numerous chemical reactions. Most common batteries on today's market are lead-acid batteries, nickel metal hydride batteries and Lithium-ion batteries.

7.2.2 Technology status in industry

Battery research is blooming at Danish universities and a number of Danish companies are using, consider using or focus on implementing batteries in commercial products. Four universities and 10 private companies have formed Danish Battery Society to share knowledge within research and application of batteries. Danish battery research is largely characterised by small groups with deep knowledge at international level within few and narrow niches. Danish Battery Society sees a need for joining forces to compete internationally.

Danish universities perform research within both battery materials and battery material processing. Combining battery research with nanomaterial research shows interesting potentials. There is on-going research in Denmark within both classical battery technologies, like on Co-, NMC-, Fe-, or Ti-based Li-Ion batteries, but also Li-S and Li-O and Zn-O are studied in Denmark. In particular for Li-O technology, Haldor Topsøe A/S and Lithium Balance in collaboration with DTU and SDU (as well as Stanford University in the US) aim to develop and understand the technology for battery application. Haldor Topsøe A/S is looking into materials for electrode production and supply of raw materials for battery manufacturers.

Battery systems research and development of peripheral components is the focus areas of Lithium Balance and Clayton Power amongst other companies in collaboration with Aalborg University and Danish Technological Institute. Advanced battery management systems with integrated diagnostics

and prognosis capabilities are under development, supported by extensive battery modelling and characterisation activities. A close collaboration with leading international research institutes and battery manufacturers secures supply of state-of-the-art cells based on Fe-, Ti- and S-based Lithium chemistries. The application-oriented research supports battery integrators in the areas of power backup systems (eg LeanEco), motion power (ECOMOVE, GMR Maskiner etc.) and grid balancing (Vestas, Siemens etc.).

Looking outside Denmark, there are a few Li-ion manufacturers in Europe, but all large-scale production is located in Asia (Japan, Korea, Taiwan and China) and USA. Several European companies and institutes make prototypes and small series for R&D or demonstration purposes. Materials, components and production equipment for battery cell production is a considerable business throughout Europe. Assembly of battery cells to battery packs including BMS is done in all European countries. R&D activities are most intense in Germany and France which may be due to their EV production.

7.2.3 Applications

Most batteries have a versatile application range with excellent scalability of both power and energy from μW and μWh to MW and MWh. Batteries are attractive as well because they react rapidly in response to changing voltage over the electrodes. From a technical point of view, batteries are therefore suitable for all kinds of fast balancing services in the electricity grid, whereas bulk energy storage (energy arbitrage) seems a little beyond the scope of batteries.

Wind turbine manufacturers (eg. Vestas and Siemens) are currently doing experimental studies on the feasibility of using large batteries (MW) in conjunction with wind turbines and wind farms to stabilise the electrical output without down-regulating the turbines. This kind of battery application is likely to become important to Danish wind turbine industry in the (near) future.

In connection with solar power installations, batteries are of interest for storing solar power in households (for use in night time), but also to prevent congestion and for voltage control in the low-voltage parts of the electrical grid (below 10kV). In the latter case, batteries may defer or supersede considerable investments in reinforced low-voltage supply lines.

In the future sustainable transport system, batteries are likely to have a prominent position for traction of vehicles (e-mobility). The trend has already been seen for quite a while, but for use in vehicles, batteries come somewhat short because of their low energy density (on weight as well as volume basis) leading to low driving range, which are not acceptable for many mobility applications. However, batteries can substitute fossil fuels completely on shorter range vehicles. Furthermore, batteries used in hybrid systems can improve energy efficiency for longer or heavier transport. The electric vehicle with batteries will also be the platform for effective use of fuel cells in the future transport.

Battery energy storage systems are finding their way in to residential and grid domains.

7.2.4 Development needs for the technology to become market mature

A major problem about battery energy storage is the low energy density. In order to increase the capacity and thereby the energy content, the next big leap will most likely be the lithium sulphur

battery, sodium ion or lithium silicon batteries²⁰ and universities struggle worldwide with the challenges in that relation. To increase the energy content a leap further, scientists, including Danish scientists and Danish industry, aim to develop lithium air battery technology, which has the potential to increase energy density by a factor 10-50. This is a long-term target and probably such batteries are unlikely to reach the market before the late 2030s.

Until recently, the main focus within the Li-ion technology was on the electrode materials and the cathode materials in particular. However, development and improvements are needed for all materials and components in the batteries from ground electrode slurries over separators, electrolytes and binders to packaging materials. One way to increase the energy content is to drive the cell voltage up towards 5 volt by improving the cathode materials (5V spinel and other), using a Li-metal anode and tailored electrolyte and separator. In general, a multitude of different materials and the combinations of these are yet to be evaluated in the laboratory and in pilot production.

Degradation is a serious problem for many types of batteries with significant implications on calendar and cycle lifetime as well as storage costs. Degradation mechanisms depend on battery chemistry and construction, and still needs much R&D attention to be decreased.

Furthermore, development of production processes will contribute to higher safety, longer lifetime, more uniform quality and lower prices. Nanotechnology for electrode materials and more accurate printing processes along with more clean and dry production facilities are just a few issues on the list. Drying the printed electrode slurry in huge energy consuming ovens may be replaced by less energy intensive technologies.

Apart from the lithium ion batteries, other emerging battery technologies like Sodium-Sulphur and flow batteries may be reviewed. It is not likely that one type of battery will be superior on all features/properties and hence several types will exist side by side in many years to come. Although the Li-ion sales has doubled ten times during the last decade, the sales of NiMH and Lead-acid has increased as well, the latter by almost 20% in spite of the fact that lead is a highly unwanted material in most countries.

In parallel with further development of the core technology and materials, characterisation methods need to be further developed to enable fast and consistent comparison of key performance metrics to guide and support development at both cell and pack levels. Novel monitoring and diagnostics methods that enable safe and reliable use of Lithium batteries and protect against operation that severely reduces lifetime must be developed. Research in improved cell-balancing technologies that maximise the effective capacity of battery pack is also required. Thermal management of battery packs needs to be further developed and the impact on pack performance must be better understood. Alongside this development, charging and discharging strategies and technologies also need to be developed to enable, for example, fast charging and possible wireless charging of mobile battery packs. Synergies with other technologies such as fuel cells in hybrid systems should be explored, as it may help bring both technologies to the market.

²⁰ Toward Silicon Anodes for Next-Generation Lithium Ion Batteries: A Comparative Performance Study of Various Polymer Binders and Silicon Nanopowders, Christoph Erk, Torsten Brezesinski, Heino Sommer, Reinhard Schneider, and Jürgen Janek, Applied Materials and Interfaces, 2013

Some commercial energy storage systems have a relative low overall efficiency – maybe because of a strong focus on lowest possible initial cost. There could be opportunities for developing higher efficiency energy storage systems either by combining Danish knowledge on energy efficient solutions or by developing dedicated high-efficiency technologies for energy storage.

7.2.5 **Specific recommendations in a Danish context**

Even though there is not any battery production in Denmark at the moment, it does make sense to support the internationally acknowledged Danish research and development in advanced battery materials. Different companies have considered producing batteries in Denmark in recent years, partly due to restrictive transport safety regulations. As sustainable energy sources penetrate the Danish electricity system, Denmark is likely to experience an increasing need for electric energy storage, and focusing Danish research on developing and demonstrating batteries of the future will support Danish industrial battery activities in international competition and cooperation.

Funding support will be needed for research in advanced battery materials, advanced production technologies, degradation, characterisation methods, battery pilot production, life cycle analysis, safety, battery second life, battery management, battery packaging, battery environmental management, battery life assessment and standards. Some of the specific technologies of relevance to Denmark are:

- **Managing and balancing** batteries to optimise life, capacity, safety, energy efficiency, reliable SoC and SoH, fast charge, self-test, multi chemistry support etc.
- **Novel monitoring and diagnostics methods** to help enhance battery life, give early warning, measure state of health, fast charging, assessment of remaining life etc.
- Energy efficient **thermal management** to prolong battery life and give optimal performance, enable fast charge etc.
- Mechanical and electrical **battery package integration** minimising energy losses and cost; optimising reliability, serviceability, safety, second-life options, modularity, scalability etc.
- **Interface and function** – mechanical and electric – to optimise integration into applications, scalability, design reuse, second-life value improvement, production, fast charging, standards, application integration etc.
- **Environmental concerns** on resource availability, materials reuse, recycling, life cycle analysis, second-life market support, hazard assessment etc.
- **Manufacturing and test** - battery pilot production for technology assessment, energy efficient production, quality enhancement, standards, battery performance verification, battery modelling, degradation prediction, post mortem analysis

Danish battery research, services and production should be encouraged to form a cooperation that can be seen as a worthy and visible partner by international battery research and industry.

7.2.6 **Players in Denmark**

Players with declared interest in battery relevant activities in Denmark:

Universities and research organisations:

- Danish Technological Institute
 - a) Research in nano-enhanced production processes.
 - b) Battery characterisation, degradation and modelling at cell and package level.
 - c) Application support
 - d) Post-mortem analysis

- Aarhus University
 - a) Research in different 'classic' Li-Ion technologies enhanced by nano processes.
 - b) Hand production of advanced prototype button battery-cells for characterisation.
 - c) New types of high capacity batteries and nano-energy materials

- Aalborg University
 - a) Battery characterisation, degradation and modelling at cell and package level.
 - b) Battery management systems, diagnostics and monitoring concepts
 - c) Thermal modelling and management
 - d) Related power electronics and charging technologies

- Technical University of Denmark
 - a) Research in different 'classic' Li-Ion technologies enhanced by nano processes.
 - b) Battery characterisation, degradation and modelling at cell and package level.
 - c) Research into new advanced energy materials

- University of Southern Denmark
 - a) Li-ion microbatteries manufactured on-location in circuits with methods of fabrications involving depositions of thin films (electrodes and electrolytes), contacting, and packaging.

Companies:

- Haldor Topsøe
 - a) catalyst production; electrode production

- DONG Energy
 - a) Complete Energy Company , from fossil oil and wind to end user

- IRD
 - a) Fuel cell systems

- Lithium Balance
 - a) Battery Management Systems

- Resound
 - a) Hearing aids

- Widex
 - a) Hearing aids

- AtoZelectronic

- a) Battery application support
- GMR Maskiner
 - a) Electric minitrucks
- Translift
 - a) Electric vehicles for internal transport
- AF trucks
 - a) Electric vehicles for internal transport

- LeanEco
 - a) Battery based UPS
- IPU
 - a) Innovation services
- DFM
 - Fundamental research within metrology

7.3 Thermo-mechanical energy storage

7.3.1 Short technology description

Thermo-mechanical energy storage technologies are found in a variety of versions and principles. Until now only simple compressed air energy storage (CAES) plants have actually been constructed and operated on a commercial basis (the first plant was constructed in Germany in conjunction with nuclear power). All other types of thermo-mechanical energy storage technologies have only been produced on pilot scale or even just considered from a theoretical point of view.

CAES is basically gas turbine technology where the compressor part and the expander part are separated by uncoupling the shafts. The storage is a large underground cavern, which is solution-mined in underground salt domes. The compressor is driven by an electric motor when charging the storage with pressurised air, whereas the expander part drives a generator while discharging the cavern storage through the turbine. The compression will increase the enthalpy and thus the temperature of the air. This is undesirable as it causes thermal stresses in the storage, as well as it lowers the volumetric capacity significantly. For this reason, the compressor train is both intercooled and after cooled. Similarly, during expansion the air temperature decreases and it should thus be heated. This is done by natural gas burners, which in practise supplies about two thirds of the energy to the expander cycle compared to the air from the storage. This large amount of energy supply from another source than the stored air dims the picture and thus a number of efficiency definitions are found in the literature. Based on exergy analysis, a rather low efficiency (~40%) is found for the electric efficiency of traditional CAES, but the spatial capacity exceeds that of pumped hydro storage.

An obvious solution for avoiding the demand for fuel supply to heat the expansion is to store the heat that is cooled away from the compression train. This idea has been investigated extensively in a large-scale EU-funded project [7]. The process involves storage of the heat in underground storage. The heat storage medium has been considered to be any option chosen among solids, liquids and phase changing materials. A crucial part of the design of an Adiabatic CAES (ACAES) facility would be the efficiency losses due to irreversibilities in the heat transfer to and from the heat storage and the pressure losses due to flow through piping. In addition, a careful thermal management of the heat storage between cycles will be required. The system will be working under very varying operating pressure asking for development of both compressor and turbine train.

In addition to CAES and ACAES, the following types of thermo-mechanical energy storage technologies should be mentioned (more information can be found in Annex A):

Isothermal compressed air energy storage

Adiabatic liquid piston compressed air energy storage. ALP-CAES

Liquid air thermo-mechanical storage

Transcritical carbon dioxide thermo-mechanical storage

7.3.2 Technology status in industry

The status for CAES in a Danish context is that a number of research projects have been done by different parties involving DONG Energy, Rambøll, DTU Technical University of Denmark, Aalborg University, Danish Technological Institute in cooperation with foreign experts. In Denmark there are significant experiences with construction and operation of natural gas underground storages. Similar facilities may be used for compressed air storage. Use of this experience for the optimal operation of a CAES facility for handling intermittency of renewable sources, mainly wind power, has led to a number of research projects. None of these projects have yet reached proposals for economically viable solutions for the current energy system. However, several options for implementation in the future are documented based on conventional and optimised CAES concepts.

The world's oldest CAES plant is in Huntorf, Germany. It has been in operation for 30 years. A new facility is under construction by Gaelectric in Northern Ireland. Two large projects have been carried out concerning the Adiabatic CAES technology, which integrates heat storage as well as storage of compressed air. The ADELE project was funded by the German state, whereas AA-CAES was an EU project led by KTH Royal Institute of Technology, Sweden. Currently, several new ideas are investigated in United States, but also European development takes place. In Germany, CAEstorage is developing small-scale liquid-piston CAES. Related solutions including liquid air (UK) and reversing heat pump technology (Switzerland) are also considered.

7.3.3 Applications

CAES has been utilised for decades - E.ON's Huntorf plant has been in operation since 1978. Its generation can be started and run up to full load within six minutes²¹. Therefore, the Huntorf power station is typically used²² as a minute reserve - secondary power reserve. Another typical use is for peak shaving in the evening, when no more pumped hydro capacity is available in the region. An additional application is associated with the wind power plants in North Germany, where the plant in Huntorf is able to quickly compensate for unexpected shortage in wind power.

The CAES facility in the USA is a 110 MW ac plant near McIntosh, Alabama. This plant performs a wide range of operating functions, ie²³ load management, ramping duty, generation of peak power, synchronous condenser duty and spinning reserve duty.

Thus CAES is able to provide a broad spectrum of valuable services to the electricity grid and considering the possibilities for solution mining in salt domes in Denmark (already used for natural gas storage), CAES appears to be a candidate for utilisation in the future Danish electricity system.

It should be noted that a study from 2009²⁴ concluded that CAES has limited value in the Danish energy system and that other storage technology options are significantly more feasible.

²¹ <http://www.eon.com/en/about-us/structure/asset-finder/huntorf.html>

²² Huntorf CAES: More than 20 Years of Successful Operation, Crotagino, Mohmeyer and Scharf, Proceeding SMRI Spring 2001 Meeting, Orlando, Florida, USA, 15-18 April 2001

²³ EPRI-DOE Handbook of Energy Storage for Transmission and Distribution Applications, 2003

²⁴ The role of compressed air energy storage (CAES) in future sustainable energy systems, H.Lund and G.Salgi, Energy Conversion and Management, Volume 50, Issue 5, May 2009, Pages 1172–1179.

7.3.4 **Developments needed in order for the technology to become market mature**

The documented long-term operation and the potential for bulk electricity storage make thermo-mechanical electricity storage principles, including CAES, attractive. Low documented efficiency of CAES technology has led to significant interest in developing intermediate heat storage for the compression heat evolved during charging for later use during discharge. This would be a major step forward for CAES technology and round cycle efficiency of 75% (electricity to electricity) is expected to be within reach.

The low efficiency of present CAES technology has generated a momentum concerning innovative ideas. In Appendix A.1, we describe some of the ideas, which are currently actively investigated (see also technology description above). The maturity of those technologies ranges from projects that have been proposed very recently and mainly are in the form of sketches to technologies, which have been demonstrated, at least at small scale.

7.3.5 **Specific recommendations in a Danish context**

No solution to bulk electricity storage has been documented yet. Conventional methods are not applicable in Denmark (PHS) or have low efficiency and significant consumption of fossil fuel (CAES). It is possible to utilise ALP-CAES in Denmark.

Further development of technology with high efficiency and high flexibility is needed.

This will involve development of

- system concepts
 - compressed air or other types
 - storage of compressed fluid and heat at varying temperatures
 - Cavern design including liquid charge/discharge lines
- system integration concepts
 - economic optimisation
 - fast start-stop
 - large capacity for energy as well as power input/output
- components
 - compressors/expanders
 - pumps/turbines
 - reversing units
 - high-temperature and low-temperature heat storage

7.3.6 **Players in Denmark**

DONG Energy

Rambøll A/S

DTU Technical University of Denmark

Aalborg University, Danish Technological Institute

DTI, Danish Technological Institute

31-01-2014

AKZO Nobel (cavern owner)

Energinet.dk (cavern owner)

7.4 Thermal energy storage

Worldwide heat demand accounts for almost 50% of the world's final energy demand²⁵ and in Denmark the fraction is likely on the same level. Furthermore, in Germany 85% of the energy consumed by households is used for space heating and sanitary water heating²⁶ and again the fraction in Denmark is likely on a similar level. Thus heating plays a dominant role in the Danish energy system (although it should be noted that heat demand can be anticipated to decrease in the future due to improved energy efficiency in buildings and appliances. With the future higher share of electricity from fluctuating renewable energy sources in the Danish energy system, highly efficient energy conversion technologies from electricity to heating and cooling is needed and thermal energy storage (TES) will become an important factor for efficient generation, supply and distribution of heat and cooling where heat supply and demand do not match in time or space. The energy should be stored at high or low temperatures to obtain extensive utilisation (high exergy content) of the stored energy, which also calls for efficient conversion technologies, new efficient insulation, new heat exchangers, new materials etc., and for effective thermal management within heating/cooling, process heat, power generation as well as optimised utilisation of renewable energy supply investments. Attractive features of TES systems are a broad spectrum of available temperatures and power levels as well as a multitude of technologies to transfer energy from one reservoir to another. Every individual application of energy in the form of heat or cold requires specific levels for temperature, power and energy capacity and therefore availability of a diverse spectrum of storage technologies, energy conversion technologies and system designs is needed in the future Danish energy system.

7.4.1 Short technology description

Thermal energy storage and corresponding conversion technologies comprises several specific technologies able to store and convert energy in different ways. Basically, the following types of thermal energy storage and conversion technologies exist:

- Sensible heat storage (SHS). Sensible heat storage is by far the dominating heat storage technology including domestic hot-water tanks, large hot-water tanks in district heating systems and large-scale storage in underground reservoirs/structures or surface pits. Each of these methods requires application of specific, advanced technologies and hold an attractive potential for large-scale heat storage. The technologies and geological preconditions are described in details in Annex A.
- Phase change materials (PCM) and latent heat storage
- Thermochemical heat storage (TCS)
- Electricity to heat, eg heat pumps (HP) and electric resistant heating
- Electricity to cooling, eg refrigeration
- Heat to electricity, eg Rankine and Organic Rankine Cycles (ORC)

By storing heat using **sensible heat storage**, the temperature of a material is increased by addition of heat. In this way heat is stored in the material and the storage properties depend on the heat capacity of the material as well as the thermal insulation of the system.

²⁵ <http://www.iea.org/topics/heat/>

²⁶ Deutsche Energie-Agentur (dena) und Energiedaten BMWi, 12/2011

In the present work we put special emphasis on the following techniques within sensible heat storage:

- Aquifer thermal energy storage (ATES) - a low-temperature underground thermal energy storage (UTES) technology which functions as a seasonal storage of cold and heat. The aquifer is accessed by two wells or multiples of two wells (typically) and screened in the same groundwater aquifer. In the winter, cooled water from a heat exchanger (or a heat pump) is pumped into the cold well, while heated water from the aquifer is abstracted from the other well and provides a heat source for the heat exchanger (or the heat pump).
- High-temperature underground thermal energy storage (HT-UTES) in hot geothermal reservoirs, where energy is stored in the underground as heat by injection of heated formation water of 75–200 °C, ie water that is somewhat warmer than the *in situ* water of the deep geothermal aquifers. The technology is in principle similar to shallow aquifer thermal energy storage (ATES), but HT-UTES in hot geothermal reservoirs utilises that the geological formation is already heated to some extent and under pressure.
- Borehole thermal energy storage (BTES) where the principle of the storage is to heat up soil and cool it down again. This is done in a closed system with vertical boreholes (30-100 m deep) filled with one or two plastic pipes and grouting. The distance between the boreholes is approx. 3 m.
- Pit thermal energy storage (PTES) based on sensible heat storage in water pits. The water should be thermally insulated in order to minimise energy losses. In particular, a lid must be applied to minimise loss from evaporation (water heat of evaporation is considerable compared to its specific heat).

By storing heat using **phase change materials**, a material is subjected to a phase change (constant temperature) induced by addition of heat. If the phase change is associated with heat of transformation (which is the case for most phase changes, eg melting) heat is stored in the transformed material and can be released by the reversed transformation. Storage properties depend on the heat of transformation and thermal insulation.

High temperature latent heat storage (HT-LHS) above 300 °C and low temperature latent heat storage (LT-LHS) below 0 °C are examples of these technologies together with traditional PCM within the temperature span between 0 °C and 300 °C.

By storing heat using **thermochemical heat storage**, a reversible chemical process involving change of system enthalpy is utilised. An example of a practically usable reaction is metal hydride splitting/formation and is illustrated by the following equation:

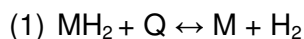

where Q is the heat required to dissociate the hydride (the hydride splitting is an endothermic process). For systems like this, storage capacity depends on the involved enthalpy change, but losses over time are reduced to zero, if the reversed process is prevented simply by isolating the evolved gas by a valve. The heat can then be regenerated by opening the valve and thereby allowing the reversed reaction of (1).

7.4.2 Technology status in industry

For heat storage in large and small hot-water tanks, Danish industry has a strong position partly because of a long tradition for using the technology in Denmark. Denmark has a leading technology position particularly within hot-water storage in district heating systems due to protracted use of combined heat and power production.

HT-UTES

In principle, all technical components needed for HT-UTES in hot geothermal aquifers are available and ready for use in such energy storage systems. However, in a worldwide context, the technology must still be considered to be in the research stage.

The Danish subsurface contains several widespread sandstone reservoirs which may be suitable for both deep geothermal exploration and heat storage, and in relation to HT-UTES, two research projects supported by the Danish Strategic Research Council (DSF) are currently carried out in Denmark. Both projects are carried out as joint research projects between several Danish research institutions and private companies, eg Danish Geothermal District Heating.

In Europe, one known demonstration project with HT-UTES in a deep reservoir (>1000 m) exists at Neubrandenburg in Germany. In this plant, HT-UTES is performed in the approx. 1250 m deep Upper Postera sandstone reservoir. The project was initiated in 2004, and hot water of 80 °C is stored in the reservoir which has a virgin temperature of 55 °C. Worldwide, only one other commercial HT-UTES project with storage temperatures >60 °C exist and it is at the Reichstag building in Germany. However, neither of the current projects utilise deep geothermal reservoirs. No current projects apart from the Danish HeHo-project deals with HT-UTES at temperatures >100 °C in deep geothermal reservoirs.

ATES

Aquifer thermal energy storage (ATES) is basically a market-mature technology and has been internationally available for several decades²⁷. In Europe, the first ATES plants were in production in the late 1980s in the Netherlands.

Although the ATES technology is well known, there are only a small number of plants in Denmark despite the very obvious economic benefit (and CO₂ emission reduction potential) and, in large parts of the country, favourable hydrogeological conditions. There has been almost no research in ATES in Denmark to support the introduction in Danish energy supply. The technology was introduced to the Danish market by a niche service company Enopsol Aps (at that time 'Energi og Miljøteknik Aps') back in the 1990s based on mainly Dutch and Swedish research and experiences.

BTES

Development of the pilot BTES design in Brædstrup has taken place in co-operation between SOLITES from Germany, PlanEnergi, GEO, Via University, Horsens, Brædstrup Fjernvarme and suppliers. The design seems to function as calculated and if monitoring results from the first couple of years are satisfying, a full-scale demonstration plant will be the next step in Brædstrup.

²⁷ European Energy Storage Technology. Development roadmap towards 2030. Joint EASE/EERA recommendations ES Technology Development Roadmap.

Probes with PEX pipes and grouting have been delivered from Germany, but all construction work has been done by Danish entrepreneurs.

In Denmark there are now 337 boreholes made for ground source heating of dwellings and family houses²⁸. The majority of these boreholes are fit for BTES with an appropriate connection to solar panels or other energy absorbers using well-known components and services from Danish Industry.

PTES

PTES must be considered a mature technology in the sense that all required components and construction techniques are well known and in control. Development of the Danish PTES design has taken place among district heating companies (primarily Marstal), consultants (PlanEnergi and SOLITES) and suppliers (GSE and PBJ Consult). Danish suppliers are involved in import of liner materials, pit excavation, welding of liner, welding and implementation of lid, production and implementation of in- and outlet and supply of connection pipes, heat exchangers, pumps, valves and control systems.

PTES outside Denmark has been built in Sweden and Germany. The Swedish facilities date back to the 1980s and are no longer in service. The German facilities are often made of concrete with a steel liner inside or with water/gravel inside so that a fixed lid can be implemented. Prices are higher than in Denmark.

LT-LHS

Freezing of water in ice-bank systems has traditionally been used as energy storage in food and farming industry for many years. By the introduction of high-efficient heat exchangers and variable-speed compressors, these technologies have been outcompeted.

Nevertheless, new technologies are under development where freezing of ice is performed by producing vacuum ice using water vapour compression technology. This technology can particularly be used in combination with large-scale heat pumps and district cooling, where energy storage is needed to counterbalance fluctuating renewable energy electricity generation or peak shaving. This technology is also very applicable for district heating applications where seawater is used as heat source for a heat pump and freezing of the seawater is desired.

HT-LHS

Converting fluctuating renewable electricity to heat and store it at high temperatures (300-700 °C) in a latent heat storage has some obviously advantages, hence the major part of the stored energy is available at the high-phase change temperature, and it can be used in a wide range of applications, eg electricity and heat production (combined heat and power plants and organic rankine cycle), industrial process industry, high-temperature fuel cells and electrolyzers, concentrated solar power etc.

Non water-based materials

In non water-based materials, sensible heat storage is utilised in Denmark in masonry stoves (in Danish: masseovn or sometimes finsk masseovn) where heat is stored in ceramic materials to provide a smooth supply of heat based on burning biomass. Danish craftsmen possess considerable knowledge within materials and construction principles for this kind of heat storage

²⁸ <http://data.geus.dk/JupiterWWW/index.jsp>

and this knowledge can be activated and utilised also for storing heat supplied in the form of electricity from renewable energy sources.

7.4.3 Applications

HT-UTES

HT-UTES technology is implemented in combination with existing or new geothermal plants, thereby enabling minimal heat loss, large storage capacity and reasonable additional costs. Furthermore, the geothermal plant capacity will be increased and waste heat from warm summer periods can substitute fossil fuel-based heat production in peak-load winter periods.

The excess heat needed to heat exchange the hot formation water to the even higher injection temperature is currently believed to be available from waste incineration plants, industrial processes, solar energy sources, or combined heat and power plants. In such facilities, excess heat is typically produced during summer when the geothermal plant is available for storage purposes.

ATES

As wind power becomes dominant in Danish power supply (50% from 2020), heat pumps and energy storage will play an important role in the main energy supply system. As a cooling technology, ATES reduces the summer peak electricity loads, hence reduces risk of power system instability. As a source of heating, ATES offers the opportunity to substitute fossil fuels for heating by wind generated electricity via heat pumps.

BTES

Largely as for PTES, see below.

PTES

In the future energy system, PTES can be used to store excess heat (up to 90 °C) from industries, incineration plants and heat from renewable energy sources as solar thermal for later use in district heating. Also PTES can integrate heat from electricity (potentially via heat pumps), solar thermal and CHP plants in complex energy systems utilising power to heat (heat pumps) in periods with low electricity price and storing heat generated by CHP plants in periods with excessive heat production.

Non water-based materials

For smaller non water-based TES systems, many new applications can be foreseen as the penetration of renewable energy sources accelerates. The ones to be available first are likely to be found within the following areas:

- Solar heating and cooling of buildings including residential buildings.
- Heat management in industry to improve energy efficiency and decrease energy demand.
- Conventional thermal power generation to improve flexibility of plants and allow for improved average fuel utilisation in combined heat and power plants.
- Improved utilisation of solar heating plants by allowing seasonal storage of heat. Also storage for shorter time periods will become attractive.
- Activation of cheap and fast electricity demand transformed to heat as a balancing service in the electricity grid (alternative to down-regulating generation).

Both PCM and TCS are still to be considered as immature technologies and to the authors' knowledge, those technologies are not commercially utilised in Denmark. However, promising R&D and demonstration projects are on-going, especially within LT-LHS and HT-LHS.

7.4.4 Development needs for the technology to become market mature

HT-UTES

Though the current research within the area deals with a large part of the possible technical challenges related to HT-UTES in deep geothermal reservoirs, some future R&D activities are needed. These include:

- Reservoir characterisation (mineralogical and petrographic composition, formation water chemistry, lateral and vertical porosity-permeability)
- Water treatment technology to prevent clogging of reservoirs, wells, heat exchangers, and pipework due to particles, gas bubbles, precipitation of minerals or bacterial growth
- Component selection to prevent scaling and corrosion
- Thermal efficiency under different geological conditions, including model based design of different storage sites for optimisation of storage temperatures as well as reservoir/temperature modelling of heat loss and optimal annual storage amount of heated water under different temperature contrasts between reservoir temperature and injected heated water
- Geochemical and rock mechanical effects in other reservoir types than currently studied

ATES

The main challenges and risks associated with the technology are related to the geological uncertainties since quite high yielding aquifers are needed and not always present. Hence an exploration phase is needed where the 'aquifer storage resource' is verified. Parallel to this, a time-consuming approval process must be completed. An approval to use an aquifer for heat and cold storage purposes cannot be taken for granted, and an application must include detailed information from geological investigations and numerical modelling, documenting that the ATES plant will not be a threat to current or future abstraction of groundwater for water supply purposes^{29, 30}. The required R&D activities and regulatory initiatives to support ATES are:

- Mapping on a national scale of the potential for heat and cold storage in the shallow subsurface (aquifers) taking district heating and cooling infrastructure and geological conditions into consideration
- National guidelines and municipal planning of the environmentally safe usage of ATES with respect to groundwater interests for water supply purposes

²⁹ Miljøministeriets bekendtgørelse nr. 1206 af 24. november 2006: Bekendtgørelse om varmeindvindingsanlæg og grundvandskøleanlæg.

³⁰ Vandplan Sjælland 2000: Miljømæssige konsekvenser af akvifer kulde- og varmelagring. Rapport udarbejdet af HOH Vand & Miljø A/S (i dag Rambøll).

- Monitoring of existing Danish ATES facilities to verify poorly documented modelling predictions of flow velocity of cold and heat plumes downstream ATES plants

BTES

The development needs for BTES are primarily related to monitoring and capacity up-scaling:

- Monitoring of the pilot plant in Brædstrup
- Attention on existing boreholes for ground source heating – some of them have installed facilities for BTES
- Experiences with cheaper drilling of boreholes
- Full-scale demonstration plant
- Demonstration plant in water-filled clay

PTES

Most development needs for PTES are related to long-term testing and capacity up-scaling. The major issues are:

- Test of life time of liners
- Test of life time and ventilation of lid constructions.
- Cheaper stores, eg by using existing infrastructure (gravel pits, dry docks from closed shipyards)
- Storage technologies for new purposes (surplus heat from industrial processes, incineration plants)
- Reliable monitoring results for demonstration plants.
- Demonstration of cheap stores for low temperature purposes (below 50 °C)
- Demonstration of larger units.

Non water-based materials

In general, cost is a main issue which needs to be addressed for new thermal storage materials and systems to become significant players on the energy market. System investment costs are still somewhat too high for heat stores not based on water.

New cheaper and more effective materials should be developed for use as PCM.

If compact long term PCM heat storage using metastable supercooling is developed, such storage technology can be a part of solar heating systems and may completely cover the yearly heat demand of buildings.

Energy density of complete thermal energy storage systems should be increased by use of more compact system designs and better storage materials.

Improving heat conductivity of storage materials is important because the conductivity sets a limit for the rate at which heat can be charged and discharged for a storage facility/system.

For many TES systems (sensible heat storage and phase change systems), thermal insulation is paramount for the storage properties. Thermal losses are too large over time and better insulation and system design are required.

Experiments are required for generation of a data basis to allow optimal integration of TES systems in the electricity grid.

Electricity to heat

Today many large capacity (MW) electric heaters have been implemented in district heating systems to be operated during low electricity price periods. By development of high-temperature (110-130 °C) heat pumps the system energy efficiency can be improved radically.

Electricity to cooling

New generations of heat exchangers for storage applications have to be developed to increase efficiency and reduce size and costs for integrated solutions of refrigeration plants and energy storage systems.

Heat to electricity

Integrated solutions for thermal electricity production (steam turbine, ORC, CSP etc.) and HT-LHS have to be developed and tested to evaluate market potential and business case.

7.4.5 Specific recommendations in a Danish context

HT-UTES

Despite a growing interest in the technology and promising research results there, is still a need for a proof-of-concept in order to kick-start the deployment of the technology, because the investment in a geothermal plant with HT-UTES facilities is rather large compared to the budget of a typical Danish district heating company. Thus, the main catalyst to initiate deployment of HT-UTES will be to establish a successful demonstration plant. Establishment of such a plant would include a variety of tasks such as exploration drilling and coring, pumping-tests, laboratory experiments, and numerical simulation of formation pressure, heat flow, etc. Such a demonstration plant could very well be established in combination with the possible large future geothermal plant in Copenhagen. In short it is recommended that:

- Full attention is paid to the results and recommendations, which can be derived from the above-mentioned on-going DSF research projects.
- Advanced computer models within topics related to the technology are applied and developed to save as much effort (costs) as possible and optimise plant design before initiating demonstration projects.
- If results from the on-going projects prove promising, establishment of a demonstration plant with HT-UTES in deep geothermal reservoirs should be supported.
- Further R&D related to the technology and the heterogeneity of the potential reservoirs (not covered by the current DSF projects) should be supported.

ATES

For ATES to become a success in Denmark, the technology has to have a more prominent position in the mind of authorities, energy planners, consultants and building architects. To reach such a position, municipalities should include ATES in their municipal energy planning and water supply

planning. Furthermore, cooperation and coordination between water and district heating/cooling utility companies will be of paramount importance and should be facilitated in the legislation.

It is further recommended that water and district heating utility companies should be given the possibility of investing in ATES and in independent district cooling companies. This would also demand new legislation. According to current legislation, district cooling companies can only be founded by commercial companies and without access to municipal financial support or guaranties. This restriction is justified by the perception that district cooling (contrary to district heating) is not a public benefit to all citizens. However, for ATES plants both the heating and cooling are to some extent of equal standing. Therefore, it can be justified that municipalities are given legal access to invest in district cooling and hence ATES.

BTES

For BTES, the next steps are demonstration of the integration into smart energy systems as for PTES and demonstration in centralised CHP systems.

PTES

For PTES, the next step is demonstration of how to integrate large heat stores in smart energy systems, where the heat storage can provide flexibility to the heat and electricity systems, move surplus heat from summer to autumn and winter and offer heat storage for 'power to heat' from heat pumps and electric boilers. Heat storage integrated into the Danish central CHP systems is of importance.

Non water-based SHS

- Perform basic research to identify and develop new thermal energy storage materials in all materials classes.
- Perform studies on utilising existing building thermal mass for energy storage

PCM

- Develop and test HT-LHS systems for different types of applications and temperature levels
- Develop metal alloys for HT-LHS
- Develop and test heat exchangers and insulation materials for HT-LHS
- Develop LT-LHS storage tanks, heat exchangers and components for pumping of two phase slurry ice, vacuum ice and PCM slurries
Perform basic research to identify and develop new advanced heat transfer fluids optimally combining heat conduction and heat storage properties in same material.
- Improve integration of heat storage properties in building elements and construction materials, eg by including phase change materials in wall constructions.
- Perform studies (theoretical and experimental) of using PCM in building envelopes to increase comfort and allow demand side management.
- Perform R&D of multi-functional thermal management materials like encapsulated PCM

Thermochemical heat storage

- Develop complete, compact heat storage systems by use of thermo-chemical reactions utilising the higher energy density

Electricity to heat

- High temperature (>110 °C) heat pumps have to be developed to be used in the transmission district heating networks and the process industry.
- Develop control strategies for integrated heat pump and heat storage systems in smart energy applications

Electricity to cooling

- Develop new efficient heat exchangers for LT-LHS energy storage applications
- Develop control strategies for the refrigeration system by integration of LT-LHS in Smart Grid

Heat to electricity

- HT-LHS integration with CHP plants, Organic Rankine Cycle and Concentrated Solar Power

General recommendations

- Perform research to improve thermodynamic properties of TES materials, eg by use of additives or composites.
- Develop new effective heat transfer mechanisms for charging and discharging heat stores
- Develop methods to reduce thermal energy losses and exergy losses from heat storage systems
- Develop modelling tools to simulate TES applications to predict performance under various working conditions (eg heat transfer, fluid dynamics).
- Develop modelling tools for TES in combination with use of heat in buildings and industry
- Develop recommendations and strategies for integrating heat storage into the Smart Grid.

7.4.6 Players in Denmark

See also Appendix A

HT UTES

DFG – Danish Geothermal District Heating (in Danish: Dansk Fjernvarmes Geotermiselskab) is a geothermal consultant and participant in the two Danish DSF research projects.

DTU – Technical University of Denmark, DTU Civil Engineering is Project Lead in the 'HeHo – Heat Storage in Hot Aquifers' DSF research project.

GEUS – Geological Survey of Denmark and Greenland is Project Lead in the DSF research project 'The geothermal energy potential in Denmark - reservoir properties, temperature distribution and models for utilization', WP Lead in the 'HeHo – Heat Storage in Hot Aquifers' DSF research project, and geological-geophysical consultant for all geothermal projects in Denmark.

ATES

Enopsol A/S, GEO A/S as consultants and contractors

Brøker A/S as drilling contractor

GEUS as research institution

Grontmij A/S, COWI A/S, Moe A/S, Niras A/S, Rambøll Danmark A/S as consultants

Heat Pumps, Heat exchangers, Pumps, Control Systems: Several

BTES

Geotechnical investigations: GEO
Drilling: Several
Import of probes / production of probes: ROTEX
Pipes in boreholes: Wawin
Cover building: several
Control system: several
Consultancy: PlanEnergi
Education: VIA University College, Horsens

PTES

Import of liners: John Hunderup
Excavation: Several
Welding of liner: PBJ Miljø
Implementation of lid: PBJ Miljø
In- and outlet: Several
Connection pipes, heat exchangers: Alfa Laval, SONDEX
Pumps: Grundfos, Desmi
Valves: Broen
Control system: Several
Consultancy: PlanEnergi, Niras, Rambøll, GEO (geotechnical consultancy)

Non water-based materials

Vølund Varmeteknik, www.volundvt.dk/
Metro Therm, www.metrotherm.dk
Danfoss
Grundfos

HT-LHS

DTI
DTU
Aalborg CSP
Verdo
Støtek

LT-LHS

DTI
Johnson Controls
Grundfos
Danfoss

Electricity to heat

DTI
Johnson Control
Advansor
Arla

Electricity to cooling

DTI

Johnson Control

Advansor

Danfoss

Grundfos

Heat to electricity

DTI

Aalborg CSP

7.5 Emerging technologies

In addition to the above-mentioned established technologies, it is important to pay attention to new ideas and take care that such ideas are evaluated thoroughly and realistically in a technical and economic perspective. Subsequently, it is important to secure sufficient RD&D support to allow a qualified decision on whether to discard the technology or nudge it into private initiatives.

One good example of such an idea is the concept of **energy membrane - underground pumped hydroelectric storage (EM-UPHS)**. The energy membrane – underground pumped hydroelectric storage (EM-UPHS) system is a novel idea for a PHS system which is based on a storage reservoir, where water is enclosed in a membrane placed underground with soil on top. The overlaying soil gives the necessary pressure to run a pump/turbine and store large amounts of electrical energy.

This system is independent of the local topology and can be placed close to a water reservoir – sea, lake, or river – with little or no height difference. The pump/turbine machinery is based on the well-known technology of conventional PHS systems which typically gives a system efficiency of 75-85%. The EM-UPHS concept seeks to facilitate a PHS system in a geographical/geological setting where the topology does not allow for a conventional PHS system.

A 50x50 m EM-UPHS test facility has recently been built and tested at Nybøl Nor, a location 12 km outside the Danish city Sønderborg. The results obtained until now show that the system efficiency of the EM – UPHS technology is close to that of the traditional and existing PHS technology.

The **next step in the development of the EM-UPHS technology** would be to design and build a pilot plant with the installed power of 1 MW and installed storage capacity of approx. 8.9 MWh. An EM-UPHS plant of this size would still not be economically viable. For the operation in the Danish power grid, it is at this moment estimated that a full-scale EM-UPHS plant must at least be in the size 30 MW/200 MWh, in order to be economically viable.

8 Schematic technology comparison

	Chemical storage	Batteries	Thermo-mechanical technologies	Sensible thermal energy storage	PCM thermal energy storage	New pumped hydro	Supercaps	SMES	Traditional pumped hydro
Seasonal storage	High rating	Low rating	Medium high rating	High rating	Medium high rating	Medium high rating	Low rating	Low rating	High rating
Daily-weekly storage	Medium high rating	Medium high rating	High rating	High rating	High rating	High rating	Low rating	Low rating	High rating
Hourly storage	Medium high rating	High rating	Medium high rating	Medium high rating	High rating	High rating	Medium low rating	Low rating	High rating
Development status	Medium high rating	Medium high rating	Medium high rating	High rating	Medium high rating	Medium high rating	Medium high rating	Low rating	High rating
Frequency service	Medium low rating	High rating	Low rating	Down Up	Low rating	Low rating	Medium high rating	High rating	High rating
Power	High rating	High rating	High rating	High rating	High rating	High rating	High rating	High rating	High rating
Energy capacity	High rating	Medium high rating	Medium low rating	High rating	Medium high rating	Medium high rating	Low rating	Low rating	High rating
Viable for mobility	High rating	Medium high rating	Low rating	Low rating	Low rating	Low rating	Medium high rating	Low rating	Low rating
Recommendation in report	High rating	Medium high rating	Medium high rating	High rating	Medium high rating	Medium high rating	Low rating	Low rating	Low rating
Danish competences	High rating	Medium high rating	Medium high rating	Medium high rating	High rating	High rating	Medium low rating	Medium low rating	Low rating
Efficiency (power to power)	Medium low rating	High rating	Medium low rating	Medium high rating	High rating	High rating	High rating	N/A	High rating
DC inverter required	Yes	Yes	No	No	No	No	Yes	Yes	No
Advantages	Versatility, energy density, infrastructure	Versatility, Efficiency, Power density	Relatively large versatility	Well suited for district heating and waste heat management	High capacity and density Potential low costs and high efficiency	Efficiency, site independence	Power density, response time	Response time	Efficiency, maturity
Disadvantages	Efficiency	Energy density	Site dependence efficiency	Irreversible	High insulation efficiency needed	Loss of land	Capacity	Immature	Strong site dependence
High rating									
Medium high rating									
Medium rating									
Medium low rating									
Low rating									

9 Danish efforts and strongholds in an international perspective

In an international perspective, Denmark has profound strongholds within energy storage, which are based on both industrial spearhead positions (particularly within district heating technology) and R&D of new storage technologies in collaboration between Danish research community and Danish industry.

Within chemical energy storage Denmark has strong R&D groupings covering a spectrum of electricity to fuel conversion technologies. It is interesting to note

- a convincing participation of those groupings in internationally funded research and development activities. This is also reflected in a high retrieval of funding from the EU R&D funding sources
- a considerable publication activity of the groupings in international, recognized scientific journals etc. as well as strong presence of the groupings in international conferences and fora.

As regards batteries, Denmark does not have a manufacturing industry and that is also the case in many other European countries. However, Denmark has developed notable competences within control, testing and characterisation of batteries in environments, which are highly relevant for Danish wind power manufacturing industry as well as for the future Danish energy system. Particularly interesting activities have been established on control systems for safe and economic operation of batteries, and in addition, internationally recognized niche developments are seen for advanced electrode materials as well as materials for the future advanced batteries. Again, scientific publication rate is indicative of the Danish standing in an international perspective.

As regards thermo-mechanical energy storage, Denmark does not have much experimental experience, if any. This is the case in most of Europe, since only one plant exists and was constructed in the 1970s. Nevertheless, considerable theoretical competence has been established in groups comprising industry, universities and the Danish Technological Institute. Those competences are also valuable internationally, and in addition, Denmark has hands-on experience with and knowledge about use and construction of large underground caverns in salt domes. This competence is a valuable asset in a national as well as in an international perspective.

As regards thermal energy storage, Denmark has superb ongoing efforts and competences in district heating technologies and many countries are looking to Denmark as a leading country. A natural implication of the extended use of district heating in Denmark is now seen in new initiatives to develop heat storage techniques aiming to separate large scale heat generation and consumption in time (on a seasonal basis). Also in these new initiatives, Denmark is in a leading position on level with very few countries in Europe. In high and low temperature PCM, Denmark has some very interesting on-going R&D activities both in industry and at the Danish Technological Institute.

As regards pumped hydro storage, Denmark is characterised by geographic and topological conditions which do not immediately indicate domestic use of this technology. However, a special variant of the technology does appear to be applicable in Danish locations, the so-called 'membrane technology'. A small start-up company is worldwide single technology player and has

brought the concept to a state where interest has been declared from major foreign companies in the energy sector.

As regards computer modelling of energy systems. Denmark has excellent competences which are already on international level. These competences could be utilised more in the future.

10 Recommendations for national Danish efforts

Denmark is generally recognized as a leading country within renewable energy technologies and the ambitious targets set by the Danish Parliament lend credibility to this viewpoint. However, the same targets call for new undertakings in the energy system and Smart Grids, energy efficiency in buildings and energy storage has been identified by the public Danish FU&D funding sources as crucial technology topics, which must be developed to facilitate reaching the targets.

The project group behind the present work estimates that energy storage will be an essential part of several sectors of the future sustainable energy system: transport, electricity, gas and heat. Energy storage is even excellently suited to provide valuable links between the sectors.

However, Denmark is not an isolated island in the universe. On the contrary, Denmark is an integrated part of Europe and is extensively integrated in the European and worldwide energy markets. Therefore, if energy storage technologies should be available and competitive on commercial terms in a not very distant future, concerted national action is required to develop the technologies technically as well as economically in close cooperation with international partners. Particularly RD&D activities could beneficially be done in cooperation with comparable, similar activities carried out by entities and organisations within the European Union. For this reason, the project group has taken inspiration – *inter alia* - in joint European recommendations for development of energy storage technologies underlying the work programme descriptions of the recently released Horizon 2020 programme. Of course, the aim has been that European support programmes and national Danish programmes should be of maximum mutual synergetic stimulation.

On these grounds, we recommend that future RD&D efforts supported by public Danish funds focus on the following areas. We stress, however, that the below listing is not exhaustive. Much more and much more detailed information about recommendations is given in the individual technology sections – particularly in Annex A.

- **Demo- or pilot projects on energy storage.** Demonstration and pilot-scale projects are often expensive activities and a careful balance must be found in such projects between public and private financial support in the light of timeframes for a business case based on the technology in question. The project group therefore proposes that relevant funding authorities join forces and
 - Consider joint announcements of dedicated calls for demo- and pilot scale projects within energy storage

based on financial contributions from more than one public funding source.

Such an initiative would allow large activities and imply a fruitful competition between storage technologies based on technology readiness level, maturity and technical relevance in the Danish energy system.

- **Chemical Energy Storage.** The technologies of storing energy in the form of chemical compounds, carbon or non-carbon containing chemical fuels, may potentially meet many challenges associated with storing energy in the future energy system. Chemical fuels are

versatile and societal appreciation, recognition and acceptance for carbon-containing fuels is high because of widespread use for centuries. Denmark has excellent industrial and research competences within electrolysis and chemical processing suited to form a variety of gaseous and liquid chemical fuels. Existing infrastructural elements, if not all of the present Danish infrastructure for distribution and storage of energy, can be utilised for fuels manufactured synthetically from electricity and (potentially) suitable carbon sources. Furthermore, chemical energy storage has outstanding capability to interact constructively with sustainable utilisation of biomass, where Denmark also is in the international forefront concerning RD&D. Chemical energy storage in fuels is the utmost technical solution to fuel transportation in a non-fossil future. However, chemical energy storage technologies need to be developed to increase efficiency, improve life time and decrease costs. For those reasons, RD&D efforts are required.

In short:

- Put emphasis on basic research and development for cheap, efficient electrolysis processes with potential to fit into the Danish electricity system.
 - Focus on experimental activities and system analyses aiming to optimise synergy between electrolysis and biogas.
 - Consider support to further studies – including small-scale experimental verification – about use of underground formations/structures for storing chemical, synthetic fuels and feedstock gases for such fuels.
 - Consider smaller projects aiming to develop necessary underlying infrastructure for utilisation of electrolysis gases
 - Allow projects to support qualified assessment of the potential for utilising electrolysis in combination with existing fuel and gas distribution infrastructure in Denmark.
- **Batteries.** Batteries have attractive storage properties in terms of high power rates and infinitesimal reaction time in response to altering voltage over the electrodes. Batteries thus have important and highly demanded services to offer in the future energy system. Batteries may enter the existing electricity grid in many locations, often without requiring grid reinforcement and even in some cases deferring needs for grid reinforcement. Batteries will inevitably play important roles in the future electricity grid, distribution and transmission, as well as within transportation, either in battery electrical vehicles or in hybrid types of traction technologies (eg fuel cells in combination with batteries). We thus find it to be important that Danish industry and research institutions are competent in a variety of battery technologies. The basis is established and it seems particularly vital that emerging Danish competences within new types of batteries with improved properties and supply of materials for advanced batteries as well as battery management systems are supported carefully to allow release of significant potentials. For these reasons, we recommend support to battery RD&D. In short:
 - Consider support to basic research in development of new types of batteries with potential for higher energy density
 - Put focus on promising niche activities aiming to develop materials for more efficient and economic batteries
 - Consider support to activities for better understanding and subsequent prevention of serious degradation mechanisms in batteries

- Allow activities aiming to integrate battery energy services with wind power production. This will be of benefit to both wind power industry and the future Danish electricity system
 - Facilitate testing and characterisation of batteries in different locations of the electricity system.
- **Mechanical storage.** Denmark has fine geological preconditions for establishing huge cavities in underground structures like salt deposits, and in addition, we have Danish competence and knowledge within construction and operation of underground pressurized cavities. Compressed air energy storage (CAES) has attractive storage properties which should be considered for use in the future Danish energy system. Denmark also has competences in industry and research, which can be activated and utilised to assess and establish CAES in Denmark. We therefore recommend support to CAES and ACAES technologies. In short:
 - Observe initiatives in foreign countries – in particular, follow the presently ongoing initiative taken by Irish Gaelectric.
 - Encourage assessment studies for CAES under Danish conditions
 - Consider support for development of heat storage techniques for use in Adiabatic CAES
 - Allow assessment studies of new types of thermo-mechanical technologies
- **Thermal energy storage.** Linking different energy sectors will become an appreciated asset of the future energy system and thermal energy storage is likely to play a central role on this scene linking electricity to heating and cooling, hence development of efficient conversion technologies is essential. Heat is the largest single form of energy demanded by consumers, whether industrial or private. Important future targets concerning energy efficiency can only be reached if heat can be efficiently and economically stored, when released as waste heat, for later use in heat consuming processes and services. Therefore, we recommend that heat storage is subjected to attention in the coming public Danish RD&D programmes. The topics of thermal energy storage comprise a number of different storage technologies and should be supported accordingly in diverse ways. Large-scale heat storage in conjunction to district heating systems over smaller scale storage of waste heat from industrial processes to small scale thermal storage in buildings and households are but examples of the future need. We therefore recommend support to development and optimisation of thermal energy storage technologies. In short:
 - Pay attention to innovative large-scale heat storage technologies. Be aware that also relatively low-temperature heat storage may be of value.
 - Encourage basic research into and development of new materials and systems for thermal energy storage (SHS, PCM and TCM)
 - Encourage development of new efficient conversion technologies, electricity to heat and cold, heat to electricity
 - Strengthen assessments of system services which can be provided by storing heat and cold in existing capacities
 - Initiate experiments with different types of heat sources in combination with thermal energy storage

- **Emerging technologies.** As stated above, it is extremely important that the funding authorities of Denmark are agile and able to respond, sometimes very fast, to new thinking, new concepts and new ideas. Therefore, we strongly urge (and take it for granted) that the recommendations given in the present report are not adopted rigidly, but rather as overall guidelines, which naturally should be deviated from, should the occasion arise. Historically, some of mankind's most powerful discoveries and developments have had roots in completely untraditional thinking, sometimes even unaccepted thinking. Everybody should bear this fact in mind.
- **System studies.** System studies have already proven to be of high value in energy planning. Also for the future system studies revealing the need for storage in the energy system will be very important. Such studies will be still more refined and precise as plans are realised and basic preconditions and data become still more solid giving reliability to modelling results.

11 Timeline

The present work has focused on required support in Denmark for RD&D within energy storage over the period towards 2020, provided energy storage should be a commercially realistic part of the Danish energy system from 2025 and beyond.

In a way, the Danish electricity system is already utilising Norwegian hydropower, and its ability to stop production in periods of low electricity prices, as a large energy storage facility. Technically, there is a fine match between wind power and hydropower, but unfortunately, often to the economic disadvantage of Danish interests, because hydropower is the flexible option. However, the Norwegian flexibility is a demanded asset and competition about the services is likely to increase in the future in parallel to construction of still more interconnecting transmission lines between Norway and the European Union (eg UK and the Netherlands).

The absolute need for energy storage in Denmark may start to emerge as early as 2025 and by that time, the Danish energy system should be prepared. This will require immediate start of development of the most market mature technologies as well as basic research in technologies, which may not be in place by 2025, but developed for commercialisation in 2030 or even later.

A. Annex A – Detailed technology information

A.1 Chemical Storage

A.1.1 Short technology description

Chemical storage means in this report conversion of electrical energy into chemical energy stored in chemical bonds. More advanced concept like direct use of sunlight for chemical conversion are omitted as they seem to be in a very early stage of development. The technology considered uses electrolysis of water (and CO₂) to generate hydrogen (and carbon monoxide).

The future Danish energy systems as envisioned by energinet.dk shows the energy value chain from production to consumption, also focusing at storage. The illustration in Fig. 1 below show hydrogen has been generated by alkaline-, PEM- or SOEC electrolyzers. For SOEC a synthesis gas as a mixture of hydrogen, CO and CO₂ also may be generated.

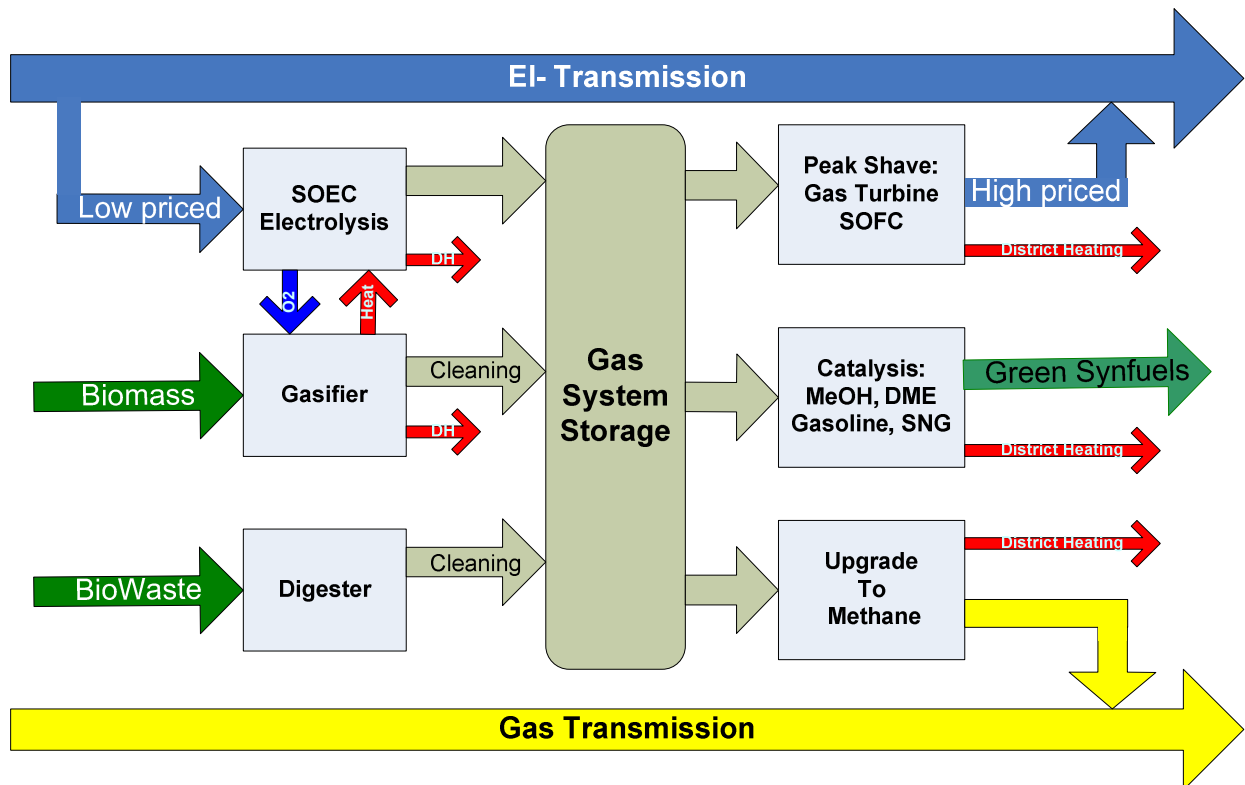

Fig. 1

Hydrogen can be used directly for energy storage or as transportation fuels. If a CO₂ is available this can be converted with hydrogen or used in a SOEC to generate synthesis gas. In both cases this opens up for the production of different synthetic and renewable fuels as shown on Fig. 2.

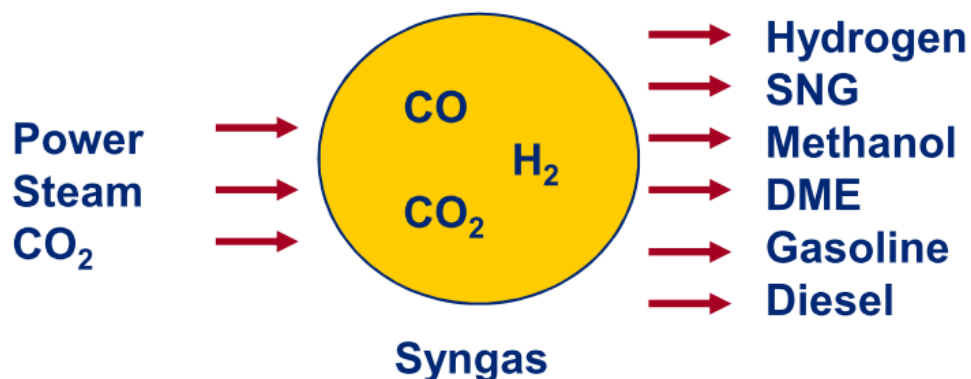

Fig. 2

All of the conversion steps to carbon containing fuels are exothermic, e.g. involves generation of reaction heat, which can be used for district heating. In the case of SOEC the waste heat can be used to generate the steam used for hydrogen production. In that case the overall conversion efficiency from electricity to fuels is enhanced considerably as electrical power is not used to evaporate water. The principle is shown on Fig. 3.

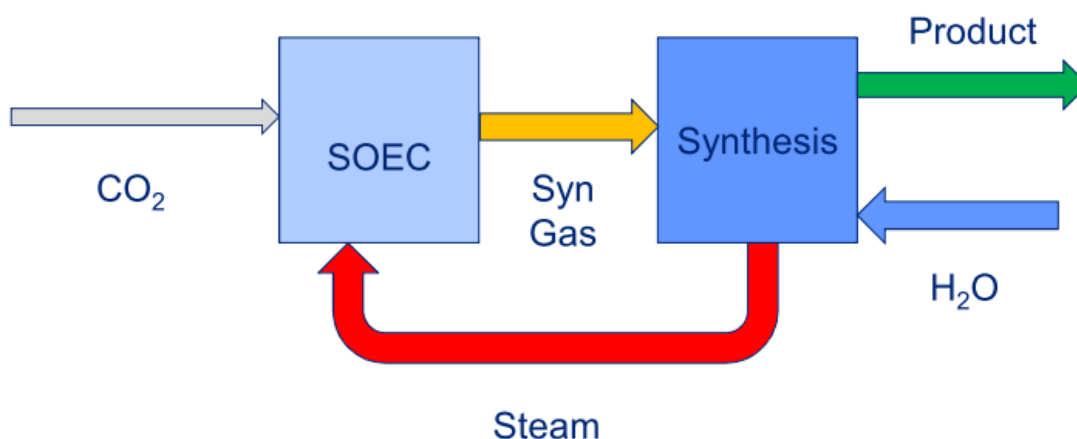

Fig. 3

Prefeasibility studies³¹ have shown that exergetic conversion efficiencies up to 80 % can be achieved if power electronic losses are ignored.

Both Danish and German analyses have shown that chemical storage is the only viable route to store/utilize massive amounts of intermittent renewable power. Furthermore this option enables reuse of existing energy infrastructure in the form of the gas grid/liquid fuel distribution channels/engines etc. There is also an interesting coupling to fuel cell technology if re-electricification is desired.

Another concept is to use onsite electrolyzers at hydrogen refuelling stations (HRS) for various energy storage and balancing purposes as outlined in Figure 4 below:

³¹ J.B. Hansen et.al.: ECS Transactions **57** (1) 3089-3097 (2013). The Electrochemical Society

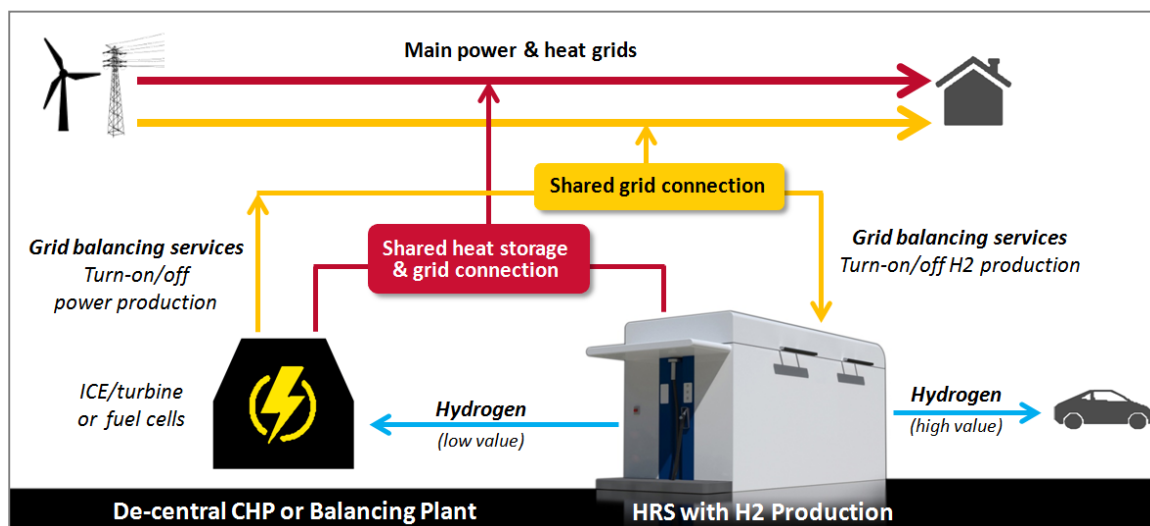

Figure 4

A HRS with onsite hydrogen production and possible hydrogen conversion plant may offer several balancing services to the grid. Also the HRS could be located at e.g. existing de-central CHP plants thus sharing heat storage and grid interfaces as well as site and personnel.

A.1.2 Short technical and economic status

There are three viable types of electrolyser technologies to be considered. They differ with respect to the electrolyte used and operating temperature.

Alkaline (AEC): The classical version of this has been used for more than a 100 years, also in large scale (> MW) applications. The technology is commercially available and well proven. The present development is primarily focused to optimize system efficiency, lifecycles, and pilot new applications including renewable energy storage and supply of hydrogen and RE gases for electricity/heat generation and transport. A focus area is optimisation of the electrode surfaces, higher operations temperature to increase the current density, higher output pressure and dynamic operation.

Proton Exchange Membrane (PEM): These are spin offs of the PEMFC technology. This technology is commercially available on small scale, and large-scale prototype systems are being demonstrated worldwide. PEM electrolysers have a simple design, a fast response to load changes (aimed for smart grid) and allow direct production of pressurised hydrogen without compressors. The technology development aims to reduce production costs while improving performance and lifetime and simultaneously increase the hydrogen pressure.

Solid Oxide Electrolysers (SOEC): These are still under development with a few (< 50 kW) demonstration units under construction in Germany and Denmark. This technology is less mature than the other two (2) technologies, but possesses a large potential to achieve high efficiency. The focus for SOEC development is on the production and optimization of demonstration units. In addition, the development of pressurized systems and methods for characterization and optimization of the cell and stacks life.

Both the presently available AEC and PEM electrolyser operates at 60 to 80 °C and have a power consumption around 5 kWh/Nm³ H₂ corresponding to an energy efficiency around 60 % on a lower heating value basis. AEC operate with a rather low current density, but has demonstrated long lifetimes. They are at present not very tolerant of load cycling though. PEM electrolyser of today has a significant amount of noble metals in the electrodes and only a few suppliers have demonstrated sufficient lifetimes. Efforts are underway to operate with improved electrodes at higher temperatures for both technologies.

SOEC is favoured by better thermodynamics due to the higher operating temperatures (around 750 °C and stack efficiencies close to 100% on a lower heating value basis (3 kWh/Nm³) have been demonstrated in lab scale. SOEC has seen a significant improvement in degradation rates (from 7%/1000 h down to below 1%/1000 h) but this still somewhat above the desirable < 0.5%/1000 h. Robustness and durability under pressurised operation need to be demonstrated. Larger cell areas would also be a benefit.

All three technologies (and especially, of course, SOEC, due to its early development phase) needs lower investment costs, but this is tied to both improved performance as well as up-scaled production facilities.

The synthesis gas conversion technologies are fully commercialised although SNG and DME production only recently.

Technology Readiness Level

Pilot level		Demonstration level			Market mature		
	X	X					

A.1.3 Technology status in Danish industry and research community

There are presently no commercial producers of electrolysers in Denmark, but the research community in Denmark is at the leading edge of electrolysis research on the following three electrolysis technologies:

- Alkaline electrolysis is presently being developed primarily by at GreenHydrogen.dk and Siemens A/S , DTU Energy Conversion, and Centre for Energy Technologies AU Herning. GreenHydrogen.dk is developing alkaline electrolysers and is approaching commercialisation of their first product. Currently, demonstration activities are ongoing for electrolysers in the 10 – 40 kW range within power back-up systems for telecommunications and for Hydrogen Refuelling Station. GreenHydrogen is working to scale its kW technology into MW scale plants together with Siemens, DTU and Aarhus University. GreenHydrogen’s MW scale technology is expected to be demonstrated for the first time in 2015-16. H2 Logic A/S is active on development of hydrogen refuelling stations with onsite production that could provide decentralised storage and balancing solutions.
- PEM electrolysis is in Denmark primarily developed at IRD A/S and DTU Energy Conversion. IRD A/S has developed a PEM stack capable of producing 1 Nm³ H₂ per h with a direct output hydrogen pressure of 100 bar. IRD is presently testing a prototype system.
- SOEC electrolysis: SOEC electrolysis developed primarily at Haldor Topsoe A/S and Topsoe Fuel Cell A/S in collaboration with DTU Energy Conversion. DTU Energy Conversion has been a pioneer within SOEC research and is world leader within co electrolysis and pressurization of SOEC stacks. Topsoe Fuel Cell A/S is also participating in EU sponsored projects on SOEC and is now delivering stacks to Haldor Topsøe A/S, which has initiated development work on SOEC systems. A 40-50 kW biogas upgrading plant is under construction sponsored by EUDP, which together with energinet.dk has also

funded other SOEC projects. The Topsoe group is the only group worldwide, which has both Solid Oxide Cells, catalyst and technology for synthesis gas conversion within the same company.

The production of renewable, synthetic fuels by means of catalytic conversion technology is an important element of chemical storage.

HaldorTopsøe is world leader in supply of catalyst and technology for synthetic fuel production.

Danish Universities and consultancy companies have established a solid foundation for simulation and optimization of sustainable energy systems. Among others ForskEl has supported an ongoing project named "MegaBalance" that are to analyse the potential for using a large scale network of hydrogen refuelling stations for balancing and storage of renewable electricity. The strategic research council has further funded a larger research consortium, HyFillFast, with participants from Korea, Germany, DTU, H2Logic and coordinated by AU for development of new technologies for hydrogen compression and combined solid state and high pressure hydrogen gas storage for mobile applications.

What are lacking in the complete value chain in a Danish context are dedicated power electronics, cost efficient water purification and large scale system integrators (including manufacturing of high pressure equipment). The important coupling to biomass gasification also needs a stronger Danish commitment. Opportunities exist within the area of system control for fluctuating operation.

A.1.4 Status in other European countries

In connection with the German "Energiewende" a substantial amount of analysis work has been carried out sponsored by the German ministries. This has spurred more than 12 so called P2G (Power to Gas) being in operation, under construction or in planning. The largest is a 6.3 MW biogas upgrading plant for Audi. Most all of the plants use alkaline technology, but one company, Sunfire, is developing SOEC P2G as well as power to liquid technology in collaboration with the German Research Institutions. Within PEM technology a plant containing the world's largest single mega-watt PEM stack, is expected to be delivered in the spring of 2014 to E.On in Hamburg³². E.On. recently (2013) put a 140 MW wind park with a 1 MW PEM electrolyser for Power-to-Gas energy storage in operation in Berlin.³³ This work is heavily funded by the German state.

In the UK substantial interest also exists so far only for hydrogen production including injection into the natural gas grid. A major player is here ITM Power using PEM technology.

In France the efforts, mainly led by CEA so far, is intensifying both focusing on nuclear power as well as renewables. A demo unit coupled to solar power is in operation in Corsica.

In Italy SOFC Power has participated in one EU project together with Spanish and German partner as well as TOFC.

³² <http://www.hydrogenics.com/about-the-company/news-updates/2013/08/29/e.on-and-swissgas-begin-commercial-operations-at-power-to-gas-facility-in-germany-using-hydrogenics-technology>

³³ <http://www.renewableenergyfocus.com/view/35124/german-wind-park-with-1-mw-hydrogenics-electrolyser-for-power-to-gas-energy-storage/>

A.1.5 Development needs for the technology to become mature for markets

For AEC it is essential to increase the energy conversion efficiency and load following performance. Corrosion and durability issues when increasing the operating temperature are important. Demonstration of suitability for 0-100 % dynamic load operation within seconds and cold start and overload capabilities will be important.

For PEM systems, the R&D focus is on cost reduction, improving performance (efficiency), increasing the robustness, and increasing the hydrogen pressure.

For SOEC the main issue remains degradation rates and robustness. Pressurized operation will be highly beneficial both from an efficiency and cost point of view. It will also be essential if reversible operation (operating the same system both in electrolysis and fuel cell mode) is considered for re-electrification.

An important feature of the technology is the ability to extend the biomass potential by a factor of 2-3. This is because biomass (CH₂O roughly) is deficient in hydrogen compared to desired high density fuels like methane or methanol.

The coupling to biomass conversion, being biogas upgrading or biomass gasification should thus merit attention. This could also provide for use of the oxygen generated in the electrolysis processes.

If the convenience of carbon based fuels and the related existing infrastructure is to be enjoyed in the future the scarce resource could in fact be CO₂. The use of closed cycles with SOEC/SOFC/Gas Turbines with oxygen combustion plants could provide a solution.

Simulations of the total energy system providing input for varying load tests on developed equipment are essential. Technology for large scale storage of hydrogen, oxygen and/or CO₂ is also important enabling elements.

Efficient power electronics development should likewise be given priority.

On use of hydrogen refuelling stations for energy storage and balancing further demonstration and analysis efforts will be needed, in particular focusing on economical optimization of production and storage sizes.

A.1.6 Danish competition position compared to position in other countries

There are so far no commercial producers of electrolyzers in Denmark, except GreenHydrogen.dk, but due to the long term, concerted R&DD efforts within fuel cells and hydrogen it is believed that Denmark is in an excellent position to develop and commercialize the more efficient and larger systems needed for deployment within the field of chemical storage.

The world leading position of Haldor Topsøe A/S within the field of heterogeneous catalysis and synthesis gas conversion creates a unique, Danish opportunity to optimize the possible synergies in coupling electrolysis and synthesis gas conversion.

Denmark's front position within wind turbine technology and deployment, district heating, sustainable energy system optimization and biogas production forms a strong home base for initial demonstration and later international roll out.

A.1.7 SET Plan targets for the technology

SET Plan targets: see Annex B.1

A.1.8 Actors in Denmark within the topic of the technology

Universities and research organisations: R&D within electrolysis and related technologies

AAU
AU
DTI
DTU Energy Conversion R&D fuel cells, electrolysis, ,
DTU CASE
DTU Chemistry
DTU Physics
DTU Mechanical
KU Chemistry
SDU

Industries: Industrial R&D and electrolyser manufactures

Greenhydrogen.dk - Alkaline electrolyzer technology
Haldor Topsøe A/. - SOEC technology, chemical conversion
IRD Fuel Cells A/S - PEM electrolysis and fuel cells
Siemens
Topsoe Fuel Cell A/S – SOFC technology

Industries: Consumers

Air Liquide, Gas handling and supply
Danish Power Systems – High Temperature Fuel Cell technology (Membrane Electrode Assemblies)
Dantherm Power, Fuel Cell power back-up systems
H2 Logic A/S, hydrogen etchnology, hydrogen filling stations
LeanEco – Power back-up systems
Serenergy, High Temperature Fuel Cells
Strandmøllen Industrigas, - Gas Handling and Supply
Utility companies e.g. DONG, TREFOR, SEAS NVE, SE – users of electrolysis technology

A.1.9 Where could the technology be integrated in the future energy system

Chemical storage can be integrated in many ways in the future energy system. Intermittent electricity production can be converted into transportation fuels like hydrogen, methane, methanol, DME, gasoline or diesel. These fuels can also be used for central or decentralized CHP production or for high temperature process heat in industry.

In the CEESA project the preferred, realistic 2050 scenario called for 8 TWh used for steam electrolysis combined with 10 TWh synthesis gas producing 17 TWh transport fuel and 21 TWh used for coelectrolysis of CO₂ and steam producing 13 TWh. This can be compared with the 8 TWh used directly for electrical vehicles.

Conversion of electricity into methane would integrate the electricity and gas grid.

Electrolysers at hydrogen refueling stations could be used for decentralized storage and balancing.

Although the conversion processes involved in chemical storage are rather efficient there are also opportunities to use the waste heat for district heating purposes, which would increase the overall conversion efficiency even further.

A.1.10 Specific recommendations for the technology in a Danish context

It is necessary to maintain and furthermore expand the R&DD activities within the electrolysis field if this key enabling technology is to play the foreseen role in the political desired future energy scenarios.

At present the Danish positions are at the leading edge, but competition in Europe and further abroad are foreseen to intensify considerably.

There is a need for continued research ranging from fundamental materials research, identifying degradation mechanisms, next generation electrodes, electrolytes and stacking solutions to demonstration units in a sufficient scale to bridge the gap from laboratory to commercial deployment in as few steps as possible. Such demonstrations should be carefully timed and sized as they by nature are quite expensive but unavoidable in order to make the solutions a reality. The funding of such demonstration units may require a concerted effort on behalf of the different actors and funding mechanisms in play today. The demonstration should take place within different applications e.g. synthetic fuel production, methanization and hydrogen fuel.

Denmark has a unique opportunity to deploy and commercialize the chemical storage technology due to the ambitious energy policy with respect to renewable electricity generation, district heating and natural gas infrastructure, its biogas potential and synergies with other untapped biomass resources.

A.2 Batteries

A.2.1 Short technology description (including working principle and categorization)

Primary battery cells are not rechargeable whereas secondary battery cells can be recharged and hence used for electricity storage. A battery cell is an electrochemical device which consists of two separated electrodes, a separator and an electrolyte. The electrodes are made of different materials causing an electrical potential between them. This potential is maintained since the separator does not allow electrons to pass through it. When a load is connected between the electrodes electrons will flow from one electrode to the other and at the same time ions are flowing from one electrode to the other inside the battery cell to keep the electrical balance in the cell.

Battery cells can be characterized by their nominal voltage and their capacity. The cell voltage is low (<4volts) but by connecting several cells in series the voltages are added, forming a battery pack of several hundred volts. In the same way battery cells connected in parallel will add up the capacity.

Batteries can handle direct current (DC) only whereas nearly all power generators except solar power generate alternating current (ac). Therefore mains electricity must be rectified and transformed to a suitable voltage level before applied to a battery. If the battery is used to power an ac-application the DC current from the battery must be transformed by an inverter. Both transformations result in energy losses.

Most common batteries at the market are lead-acid batteries, Nickel Metal Hydride batteries and Lithium-ion batteries.

A.2.2 Short technical and economic status

Lead-acid and Nickel metal hydride technologies are mature and well proven. The same is the case for some Lithium-ion (Li-Ion) technologies but the potential for further development and innovations is large within this technology.

In e-mobility applications improvements are needed for energy density, lifetime and safety. In energy storage system (ESS) applications improvement on calendar and cycle life is needed. For both applications the price is a major issue and an extended temperature range is desirable.

The huge mobile energy consumers are transport devices (mopeds, cars, buses, trucks forklifts, ships and aeroplanes) but the market for cell phones, laptops, iPods and similar products is not expected to drop in the years to come.

For stationary batteries (UPS, residential PV/windmill storage, sub-grid ESS, power grid ESS and energy ESS) the lifetime and cost are the major issues. Lead-Acid, NiMH, NaS, NiZn, Lithium-ion, zebra and flow battery technologies may all serve in large stationary energy storage systems but the need for long calendar lifetime, low cost per cycle, high round-trip efficiency, low self-discharge and O&M cost as well as high C-rates in auxiliary services point at Lithium-Ion if the price decreases as expected.

The annual battery (package) sales in 2012 were 275 Mia DKK worldwide and the expected sales rise is more than 5% pr. year. In average the worldwide production capacity is about 30%

higher than the actual demand which keep prices down. However large scale production has lowered the Li-ion cell prices by 80% during the last 10 years.

Technology Readiness Level

Pilot level			Demonstration level			Market mature		
							X	

A.2.3 Technology status in Danish industry and research community

Battery research is blooming at Danish universities and a number of Danish companies are using, consider using or focusing on implementing batteries in commercial products. Four Universities and 10 professional companies have formed Danish Battery Society to share knowledge within research and application of batteries. Danish battery research is largely characterized by small groups with deep knowledge at international level within few and narrow niches. Danish Battery Society sees a need for joining forces to compete internationally. Danish Universities research both energy materials and materials process. Combining battery research with nano process research shows interesting potentials. There is research into both classical battery technologies like on Co, NMC, Fe, or Ti based Li-Ion but also LiS and LiO and ZnO is researched in Denmark.

Research in cell chemistry is typically done at the universities whereas battery modelling, characterization and lifetime testing is also performed other places like Danish Technological Institute. Topsøe is looking into electrode production for battery manufacturing. In the application support, Lithium Balance is offering advanced battery management systems for automotive and stationary systems. Integrators of batteries can find assistance from Universities, Danish Technological Institute and the battery suppliers. Li-Ion based batteries are used e.g. for some small trucks working in areas where noise is critical.

A.2.4 Status in other European countries (industrial applications, demonstration activities, research and development)

There are a few Li-ion manufacturers in Europe, but all large scale production is located in Asia (Japan, Korea and China) and USA. Several European companies and institutes make prototypes and small series for R&D or demonstration purposes. Materials, components and production equipment for battery cell production is a considerable business throughout Europe. Assembly of battery cells to battery packs including BMS is done in all European countries. R&D activities are most intense in Germany and France which may be due to their EV production.

A.2.5 Development needs for the technology to become mature for markets

In order to increase the capacity and thereby the energy content the next big leap will most likely be the Lithium sulphur, sodium ion or Lithium silicon batteries³⁴ and researchers struggle worldwide with the challenges associated with maturing the technology. To increase the energy content even further, scientists aim to develop a Lithium air battery but it is very unlikely to hit the market before in the late 2030's.

³⁴ Toward Silicon Anodes for Next-Generation Lithium Ion Batteries: A Comparative Performance Study of Various Polymer Binders and Silicon Nanopowders, Christoph Erk, Torsten Brezesinski, Heino Sommer, Reinhard Schneider, and Jürgen Janek, Applied Materials and Interfaces, 2013

Until recently, the main focus within the li-ion technology was the electrode materials and the cathode material in particular. However development and improvements are needed for all materials and components in the batteries from grinded electrode slurries over separators, electrolytes and binders to packaging materials. One way to increase the energy content is to drive the cell voltage up towards 5 volt by improving the cathode materials (5V spinel and other), using a Li-metal anode and tailored electrolyte and separator. In general, a multitude of different materials and the combinations of these are yet to be evaluated in the laboratory and in pilot production.

Furthermore, development of production processes will contribute to higher safety, longer lifetime, more uniform quality and lower prices. Nanotechnology for electrode materials and more accurate printing processes along with more clean and dry production facilities are just a few issues on the list. Drying the printed electrode slurry in huge energy consuming ovens may be replaced by less energy intensive technologies.

Apart from the lithium ion batteries, other emerging battery technologies like Sodium-Sulphur and flow batteries may be reviewed. It is not likely that one type of battery will be superior on all features and hence several types will exist side by side in many years to come. Although the li-ion sales has doubled ten times during the last decade, the sales of NiMH and Lead-acid has increased as well, the latter by almost 20% in spite of the fact that Lead is a highly unwanted material in most countries.

In parallel with further development of the core technology and materials, characterization methods need to be further developed to enable fast and consistent comparison of key performance metrics to guide and support development at both cell and pack levels. Novel monitoring and diagnostics methods that enable safe and reliable use of Lithium batteries and protect against operation that severely reduces lifetime must be developed. Research in improved cell balancing technologies that maximize the effective capacity of battery pack is also required. Thermal management of battery packs needs to be further developed and the impact on pack performance must be better understood. Alongside this development, charging and discharging strategies and technologies also need to be developed to enable for example fast charging and possible wireless charging of mobile battery packs. Synergies with other technologies such as fuel cells in hybrid systems should be explored as it may help bring both technologies to the market.

Some commercial energy storage systems have a relative low overall efficiency – maybe because of a strong focus on lowest possible initial cost. There could be opportunities for developing higher efficiency energy storage systems either by combining Danish knowledge on energy efficient solutions or by developing dedicated high efficiency technologies for energy storage.

A.2.6 SET plan targets for the technology

SET Plan targets: see Annex B.2

A.2.7 Actors in Denmark within the topic of the technology

Actors with declared interest in battery relevant activities in Denmark:

Universities and research organizations:

- Danish Technological Institute

- a) Research into nano enhanced production processes.
- b) Battery characterization, degradation and modelling at cell and package level.
- c) Application support
- d) Post mortem analysis
- Aarhus University
 - a) Research into different “classical” Li-Ion technologies enhanced by nano processes.
 - b) Hand production of advanced prototype button battery-cells for characterization.
 - c) New types of high capacity batteries and nano-energy materials.
- Aalborg University
 - a) Battery characterization, degradation and modelling at cell and package level.
 - a) Battery management systems, diagnostics and monitoring concepts
 - b) Thermal modelling and management
 - c) Related power electronics and charging technologies
- Technical University of Denmark
 - a) Research into different “classical” Li-Ion technologies enhanced by nano processes.
 - b) Battery characterization, degradation and modelling at cell and package level.
 - c) Research into new advanced energy materials
- University of Southern Denmark
 - a) “Li-ion microbatteries manufactured on-location in circuits with methods of fabrications involving depositions of thin films (electrodes and electrolytes), contacting, and packaging.

Companies:

- Haldor Topsøe
 - a) catalyst production; materials for electrode production
- DONG Energy
 - a) Complete Energy Company . from fossil oil and wind to end user
- IRD
 - a) Fuel cell systems
- Lithium Balance
 - a) Battery Management Systems
- Resound
 - a) Hearing aids
- Widex
 - a) Hearing aids
- AtoZelectronic
 - a) Battery application support
- GMR Maskiner
 - a) Electric minitrucks
- Translift
 - a) Electric vehicles for internal transport
- AF trucks
 - a) Electric vehicles for internal transport
- LeanEco
 - a) Battery based UPS
- IPU
 - a) Innovation services
- DFM

Fundamental research within metrology

A.2.8 Specific recommendations for the technology in a Danish context

There must be relevant research and demonstration programs available on battery materials, processes, and systems to advertise the specialist knowledge and keep it up to date.

Denmark is likely to see increasing need for electric energy storage which could attract battery production or battery integrators. Energy efficient and cost effective energy storage systems could also very well be future Danish products. To support such a development and the future advanced battery applications Danish research must develop and demonstrate State-of-the-Art knowledge on all aspects of battery integration in international competition and cooperation. Research and demonstration programs addressing both energy efficient storage systems and specific relevant technologies will help keeping Danish development on leading edge. Some of the specific technologies that have Danish relevance are:

- **Managing and balancing** batteries to optimise life, capacity, safety, energy efficiency, reliable SoC (State of Charge) and SoH (State of Health), fast charge, self-test, multi chemistry support etc.
- **Novel monitoring and diagnostics methods** to help enhance battery life, give early warning, measure state of health, fast charging, assessment of remaining life etc.
- Energy efficient **thermal management** to prolong battery life and give optimal performance, enable fast charge etc.
- Mechanical and electrical **battery package integration** minimising energy losses and cost; optimising reliability, serviceability, safety, second life options, modularity, scalability etc
- **Interface and function** – mechanical and electric – to optimise integration into applications, scalability, design reuse, second life value improvement, production, fast charging, standards, application integration etc.
- **Environmental concerns** on resource availability, materials reuse, recycling, life cycle analysis, second life market support, hazard assessment etc.
- **Manufacturing and test** - battery pilot production for technology assessment, energy efficient production, quality enhancement, standards, battery performance verification, battery modelling, degradation prediction, post mortem analysis

Danish battery research and services and production should be encouraged to form a cooperation that can be seen as a worthy and visible partner by international battery research and industry.

A.3 Thermo-Mechanical Energy Storage

Thermo-mechanical energy storage technologies are found in a variety of versions and principles. Until now only simple Compressed Air Energy Storage (CAES) plants have actually been constructed and operated on a commercial basis (the first plant was constructed in Germany in conjunction with nuclear power). All other types of thermo-mechanical energy storage technologies have only been produced on pilot scale or even just considered from a theoretical point of view.

A.3.1 Short technology description

Compressed Air Energy Storage, CAES

CAES is in operation at two sites worldwide, Huntorf in Northern Germany and McIntosh in Alabama. Furthermore, Irish GAElectric has made initial experimental investigations for yet another installation in Ireland and expects to start construction in 2015³⁵.

CAES is basically gas turbine technology where the compressor part and the expander part are separated by uncoupling the shafts. The storage is a large underground cavern, which is solution-mined in underground salt domes. The compressor is driven by an electric motor when charging the storage with pressurized air, whereas the expander part drives a generator while discharging the cavern storage through the turbine. The compression will increase the enthalpy and thus the temperature of the air. This is undesirable as it causes thermal stresses in the storage, as well as it lowers the volumetric capacity significantly. For this reason, the compressor train is both intercooled and after cooled. Similarly, during expansion the air temperature decreases and it should thus be heated. This is done by natural gas burners, which in practise supplies about 2/3 of the energy to the expander cycle compared to the air from the storage. This large amount of energy supply from another source than the stored air dims the picture and thus a number of efficiency definitions are found in the literature. Based on exergy analysis, a rather low efficiency (~40%) is found for the electric efficiency of traditional CAES, but the spatial capacity exceeds that of pumped hydro storage.

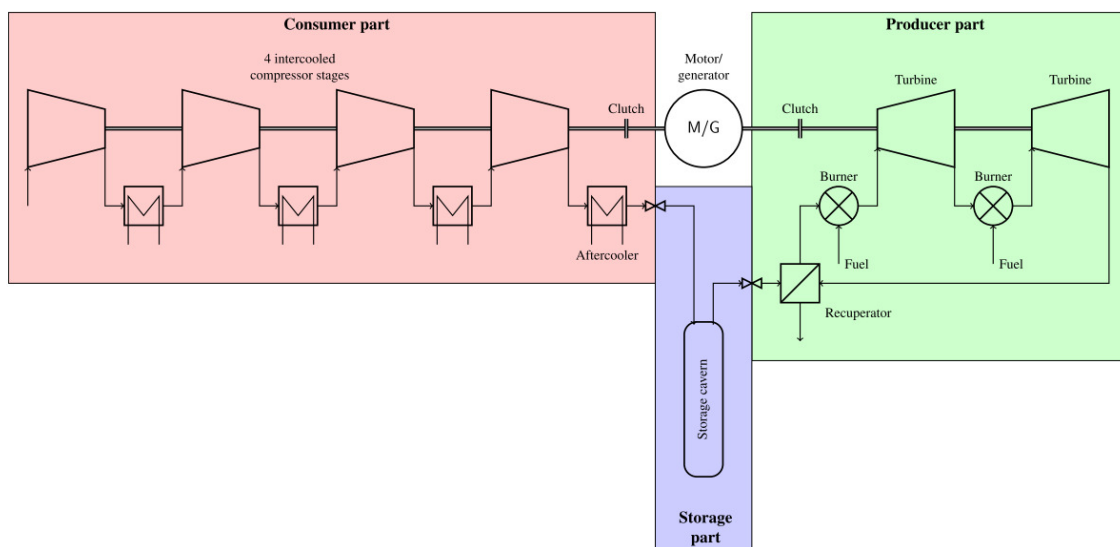

Figure 1 Principle of Compressed Air Energy Storage

³⁵ <http://www.gaelectric.ie/index.php/energy-storage/larne/project-update-2/>

Adiabatic Compressed Air Energy Storage, ACAES

An obvious solution for avoiding the demand for fuel supply to heat the expansion is to store the heat that is cooled away from the compression train. This idea has been investigated extensively in a large EU-funded project³⁶. The process involves storage of the heat in underground storage. The heat storage medium has been considered to be any option chosen among solids, liquids and phase changing materials. A crucial part of the design of an Adiabatic CAES facility would be the efficiency losses due to irreversibilities in the heat transfer to and from the heat storage and the pressure losses due to flow through piping. In addition, a careful thermal management of the heat storage between cycles will be required. The system will be working under very varying operating pressure asking for development of both compressor and turbine train.

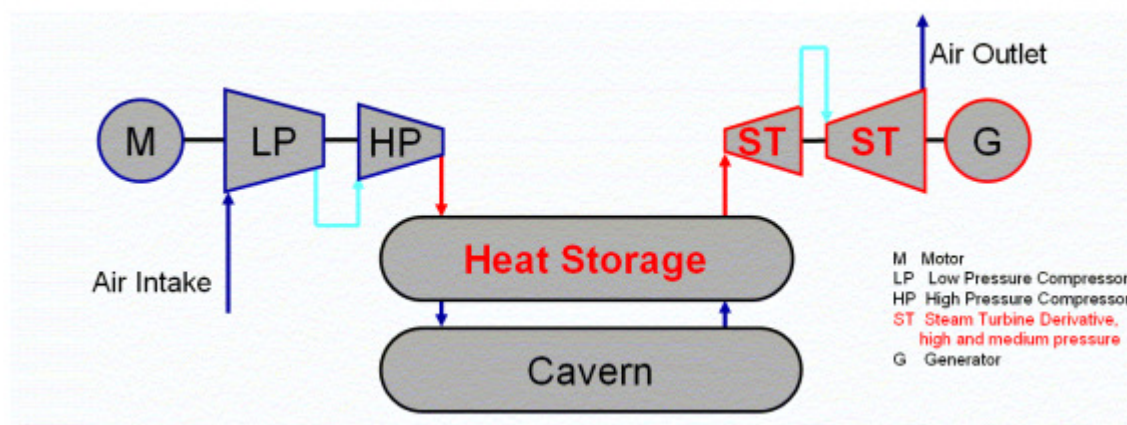

Figure 2 Principle of Adiabatic CAES

Isothermal Compressed Air Energy Storage

Another approach of avoiding the demand for cooling during compression is to target isothermal compression, as well as isothermal expansion. The idea of the isothermal compression is described, but the expansion is done analogously. Isothermal compression is the compression process, which would require the lowest specific work to compress a gas. This idea is investigated on an innovative, commercial basis by both LightSail Inc. and General Compression Inc. For many types of technologies, it would be a breakthrough if isothermal compression were available. The companies have patented different solutions, but both are based on keeping a constant temperature of the gas under compression by adding a liquid. LightSail's technology is based on spraying liquid water as a mist into the cylinder of a piston compressor during both compression and expansion as illustrated in Figure 3³⁷. The water is stored in a separate tank. General Compression Inc. has introduced a concept where the liquid injection is controlled to keep the gas temperature constant during the compression³⁸. For the proposed processes to work, power is required for pumping the liquid into the cylinder. In addition, the water storage will need thermal management due to the irreversibilities of the machines.

³⁶ C. Bullough, C. Gatzel, C. Jakiel, M. Koller, A. Nowi and S. Zunft, "Advanced Adiabatic Compressed Air Energy Storage for the Integration of Wind Energy", Proceedings of the European Wind Energy Confer, London, 2004.

³⁷ J. E. P. Berlin, S. E. Crane and D. A. Fong, "Compressed air energy storage system utilising twophase flow to facilitate heat exchange". USA Patent US 8037677 B2, 2011.

³⁸ M. Blieske, "Systems and methods for optimizing thermal efficiency of a compressed air energy storage System". USA Patent US8272212 B2, 2012.

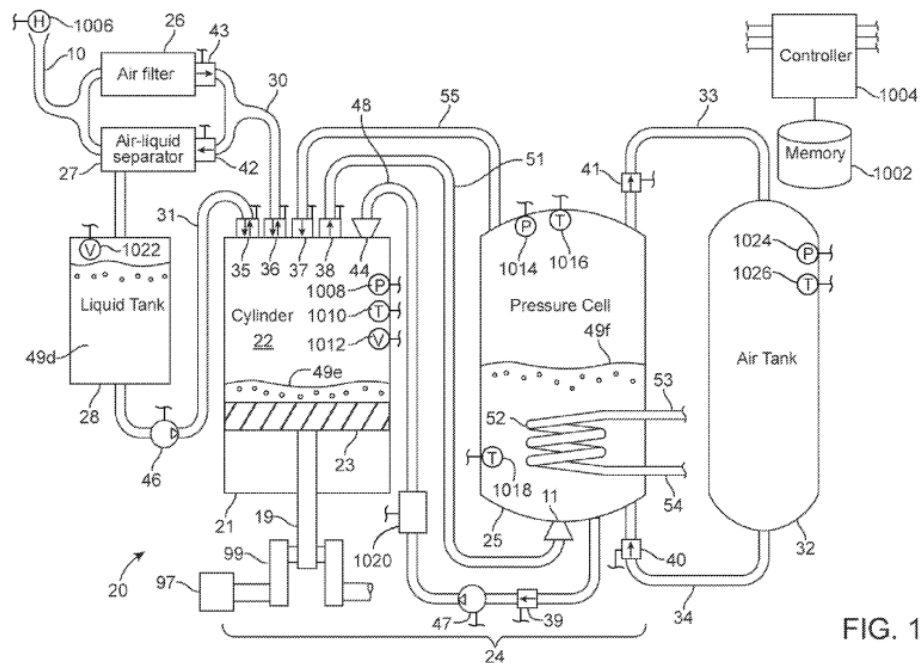

FIG. 1

Figure 3 Principle of isothermal compressed air energy storage as patented by LightSail Inc.

Adiabatic Liquid Piston Compressed Air Energy Storage, ALP-CAES

In a recent project, a combination of underground PHS and CAES was investigated³⁹. The suggested idea is a dedicated electricity storage plant, which involves a compressed air storage in an underground cavern. Contrary to a traditional CAES, the air is compressed by pumping liquid water into the cavern. As pressurization of liquid water causes a lower temperature increase than compression of air, there is no demand for cooling of the machines. In addition, only a small temperature increase of the air in the cavern is observed due to the lower pressure ratio of this. The most important concerns of this method seem to be that the cavern is solution-mined, and if the water pumped into it is not saturated with salt, the cavern will increase in size during operation. Thus a ground level water reservoir for saturated salt water will be needed. The potential energy required for moving the water to ground level during expansion causes a significant decrease of the storage capacity. Compared to traditional CAES the investment and running cost of the machinery will be significant lower but as the a larger storage volume is needed along with a significant larger diameter connecting lines the cost of the cavern system will be larger. In this content the reuse of existing but phased out caverns from solution mining is very interesting.

³⁹ T. Petersen, B. Elmgaard and A. S. Pedersen, "Adiabatic Liquid Piston Compressed Air Energy Storage", 2013.

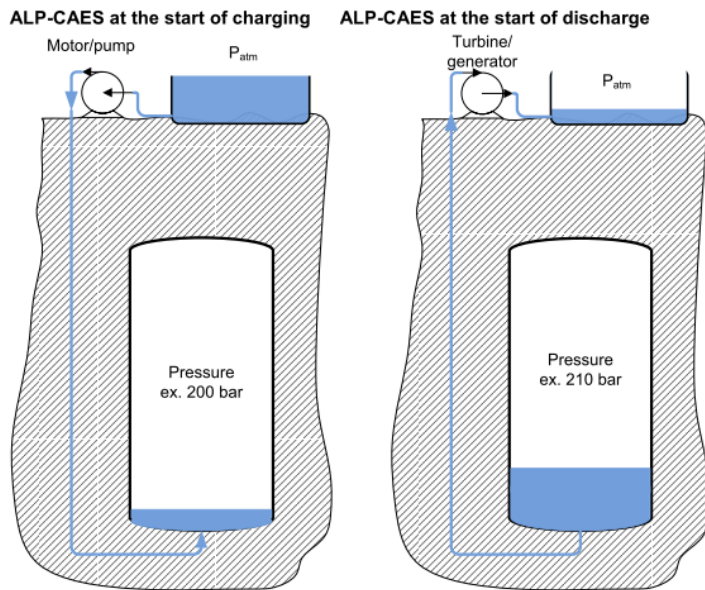

Figure 4 Principle of Adiabatic Liquid Piston CAES

Liquid Air Thermo-Mechanical Storage

The Highview Power Storage concept is based on technology for liquid Nitrogen (or air) production⁴⁰. During production of liquid Nitrogen, the gas is compressed, cooled and expanded to obtain a liquid at low pressure compared to CAES technology. The liquid air is stored in tanks during charging. When discharging the storage the liquid is pumped to high pressure, re-evaporated and expanded to produce power. The technology is currently operated at a test facility and has the option of integration of waste heat from nearby facilities. Figure 5 illustrates the process. As the liquid Nitrogen production in itself involves significant irreversibilities and thus lowers the storage efficiency, it is of significant importance to develop highly integrated recovery solution if this technology should reach high efficiency.

⁴⁰ The Centre for Low Carbon Futures, "Liquid Air in the energy and transport systems" , 2013.

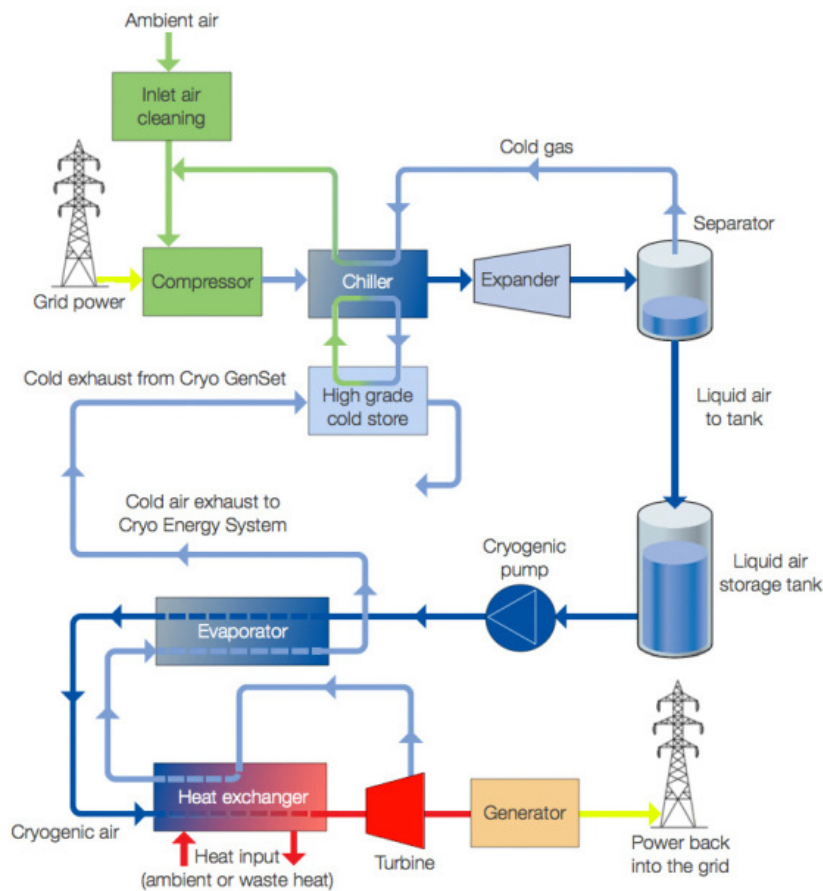

Figure 5 Liquid Air Electricity Storage developed by Highview Power

Transcritical Carbon Dioxide Thermo-Mechanical Storage

Another idea based on transferring technology from other fields is based on a heat pump cycle utilizing carbon dioxide as the working fluid⁴¹. Carbon dioxide as heat pump working fluid has recently received significant focus, but the idea was introduced already early in the twentieth century for electricity storage⁴². The technology utilizes a transcritical CO₂ cycle and thus involves evaporation at subcritical pressure, compression and gas cooling at supercritical pressure. The evaporation accordingly occurs at constant temperature, which matches well with a water-ice storage. The gas cooling occurs with temperature glide and is integrated with sensible heat water storage. The principle of the technology is illustrated in Figure 6. The method will require development of large-scale and highly efficient components for the reversible compressor/expander unit. Such technology is not commercially available currently.

⁴¹ Y. M. Kim, "Novel concepts of compressed air energy storage and thermo-electric energy storage", École Polytechnique Fédérale de Lausanne, Lausanne, 2012.

⁴² M. Mercangoz, J. Hemrle, L. Kaufmann, A. Z' Graggen and C. Ohler, "Electrothermal energy storage with transcritical CO₂ cycles", *Energy*, **45**, pp. 407-415, 2012.

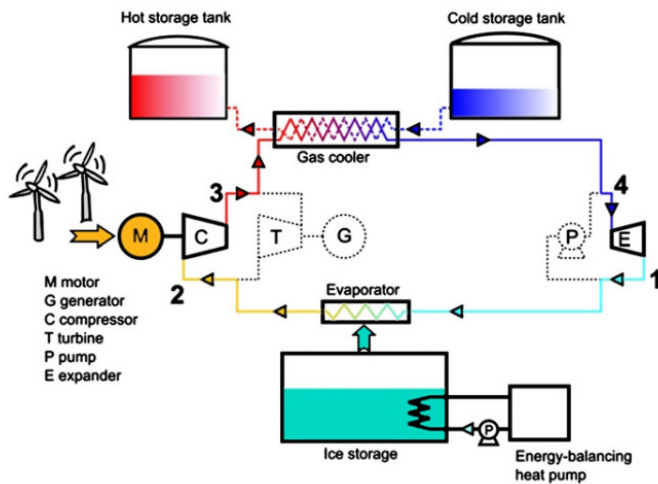

Figure 6 Principle of Transcritical CO2 cycle

A.3.2 Short technical and economic status

CAES has unique features, which make it attractive in bulk storage and market mature. However, it also involves some disadvantages, which have triggered ideas for further research and development of thermo-mechanical storage technology. These technologies are all at research and/or development state.

The most important challenge for the extended use of CAES as a pure electricity storage is the demand for a fuel suited for the gas turbine during discharging. This target may be reached if the heat removed from the compression process could be stored during charging and utilized during discharging efficiently. Other methods, involve that gas from biomass conversion or hydrogen produced by electrolysis based on renewable energy sources may be substitutes for fossil fuels. However, firstly, these are not presently available. Secondly, it will still make CAES questionable for electricity storage, both due to the high share of fuel and the low efficiency with respect to electricity storage.

Technology Readiness Level

Pilot level		Demonstration level		Market mature	
	X	X			

A.3.3 Technology status in Danish industry and research community

The status for CAES in a Danish context is that a number of research projects have been done by different parties involving DONG Energy, Rambøll, DTU Technical University of Denmark, Aalborg University, Danish Technological Institute in cooperation with foreign experts. In Denmark there are significant experiences with construction and operation of natural gas underground storages. Similar facilities may be used for compressed air storage. Use of this experience for the optimal operation of a CAES facility for handling intermittency of renewable sources, mainly wind power, has led to a number of research projects. None of these projects have yet reached proposals for economically viable solutions for the current energy system, However, several options for implementation in the future are documented based on conventional and optimized CAES concepts.

A.3.4 Status in other European countries (industrial applications, demonstration activities, research and development)

The world's oldest CAES plant is in Huntorf, Germany. It has been in operation for 30 years. A new facility is under construction by Gaelectric in Northern Ireland. Two large projects have been carried out concerning the Adiabatic CAES technology, which integrates heat storage as well as storage of compressed air. The ADELE project was funded by the German state, whereas AA-CAES was an EU project led by KTH Royal Institute of Technology, Sweden. Currently several new ideas are investigated in United States, but also European development takes place. In Germany, CAEstorage is developing small-scale liquid-piston CAES. Related solutions including liquid air (UK) and reversing heat pump technology (Switzerland) are also considered.

A.3.5 Development needs for the technology to become mature for markets

The documented long-term operation and the potential for bulk electricity storage make thermo-mechanical electricity storage principles, including CAES, attractive. But the above-mentioned challenges have generated a momentum concerning innovative ideas. Below we describe some of the ideas, which currently are actively investigated. The maturity of the presented technologies ranges from projects that have been proposed very recently and mainly are in the form of sketches to technologies, which have been demonstrated, at least at small scale.

A.3.6 Danish competition position compared to position in other countries

Denmark is in focus as demonstration site for several developers. For ALP-CAES possible sites having very large cavern volumes exists.

Ideas among several Danish stakeholders may be utilized for practical implementation.

Denmark is the leading nation in the field of utilizing CO₂ in refrigeration systems and heat pumps. This combined with in depth knowledge on turbo compressors and expanders is a strong base for industrialization of transcritical Carbon Dioxide Thermo-Mechanical Storage.

A.3.7 SET plan targets for the technology

SET Plan targets for CAES technologies towards 2030 and beyond: see Annex B.3

A.3.8 Actors in Denmark within the topic of the technology

DONG Energy, Rambøll, DTU Technical University of Denmark, Aalborg University and Danish Technological Institute have worked with thermochemical energy storage technologies and made techno-economic assessments

AKZO Nobel and Energenet.dk are cavern owners.

A.3.9 Specific recommendations for the technology in a Danish context

No solution to bulk electricity storage has been documented yet. Conventional methods are not applicable in Denmark (PHS) or have low efficiency and significant consumption of fossil fuel (CAES). ALP-CAES is possible to utilize in Denmark.

Further development of technology with high efficiency and high flexibility is needed.

This will involve development of

- system concepts
 - compressed air or other types
 - storage of compressed fluid and heat at varying temperatures
 - Cavern design including liquid charge/discharge lines

- system integration concepts
 - economic optimization
 - fast start-stop
 - large capacity for energy as well as power input/output
- components
 - compressors/expanders
 - Pumps/turbines
 - reversing units
 - high-temperature and low-temperature heat storage

A.4 High-Temperature Underground Thermal Energy Storage (HT-UTES)

A.4.1 Short technology description (including working principle and categorization)

In High-Temperature Underground Thermal Energy Storage (HT-UTES) in hot geothermal reservoirs, energy is stored in the underground as heat by injection of heated formation water of 75–200°C, i.e. water that is somewhat warmer than the *in situ* water of the deep geothermal aquifers. The technology is in principle similar to shallow Aquifer Thermal Energy Storage (ATES), but HT-UTES in hot geothermal reservoirs utilizes that the geological formation is already heated to some extent and under pressure. This way, storage of water at very high temperatures (potentially up to approximately 200°C) can be carried out with a minimal loss of heat compared to storage in shallow and relatively cold aquifers of few hundred meters depth.

The heat storage is implemented in combination with existing or new geothermal plants, thereby enabling minimal heat loss, large storage capacity and reasonable additional costs. Furthermore, the geothermal plant capacity will be increased and waste heat from warm summer periods can substitute fossil fuel-based heat production in peak load winter periods.

The excess heat, that is needed to heat exchange the hot formation water to the even higher injection temperature, is currently believed to be available from waste incineration plants, industrial processes, solar energy sources, or combined heat and power plants. In such facilities, excess heat is typically produced during summer when the geothermal plant is available for storage purposes.

A.4.2 Short technical and economic status (technology readiness level)

In principle, all technical components needed for HT-UTES in hot geothermal aquifers are available and ready for use in such energy storage systems. Thus, heat exchangers and pumps durable at high temperature as well as other technical installations are developed and available in the market. Furthermore, exploration and development with regard to implementation of geothermal plants has experienced renewed interest and activity due to increasing energy prices in general, but specifically after 2000 due also to the implementation of the Kyoto protocol. As a result, there are good expectations that suitable geothermal reservoirs may be present for the deployment of the technology. However, in a worldwide context, the technology must still be considered to be in the research stage following the ENS technology readiness classification system.

Based on experience from one German demonstration project at Neubrandenburg where hot water of 80°C is stored in a sandstone reservoir with a virgin temperature of 55°C, it is estimated that potentially 65-75 % of the energy stored may be retrieved after an initial period of approximately 5 years of storage, during which a larger percentage of the stored heat is utilized to heat up the geological formation. However, due mainly to a lower demand for energy than the plant was designed for as well as too high return temperatures in the district heating system, the present recovery coefficient at Neubrandenburg is around 50%. Currently, only one other HT-UTES project exists at the Reichstag in Berlin, Germany while a few previous projects in the Netherlands have been shut down. So far, storage at temperatures >100°C has not been tried.

Technical challenges mainly include high return temperatures on the surface site and hydrogeochemical challenges such as precipitation of scales as well as increased weathering of the geological formation with possible formation damage as the result.

So far, the technology is considered to be economically viable if great care is taken when selecting the concept and designing the actual plant. The investment related to establishment of HT-UTES in deep geothermal reservoirs is rather high due mainly to the drilling of boreholes for storage and withdrawal of water from the reservoir, and implementation should be in combination with existing or new geothermal plants. Nevertheless, further economic calculations are needed including energy budget calculation in order to better elaborate on the economic aspects.

Technology Readiness Level

Pilot level			Demonstration level			Market mature		
		X						

A.4.3 Technology status in Danish industry and research community

The Danish subsurface contains several widespread sandstone reservoirs which may be suitable for both deep geothermal exploration and heat storage. Sandstone reservoirs occurring in the depth interval 0.8–3 km are of interest as these most likely fulfil the demand of sufficiently high temperatures (30–100 °C) as well as suitable reservoir properties, in particular sufficient flow capacity (permeability) of warm water.

In relation to HT-UTES, two research projects supported by the Danish Strategic Research Council (DSF) are currently carried out in Denmark. The project “The geothermal energy potential in Denmark - reservoir properties, temperature distribution and models for utilization” is related to HT-UTES in the sense that it, amongst others, deals with mapping of the geothermal potential in Denmark as well as possible relations between diagenesis and reservoir characteristics such as porosity and permeability. The project “HeHo – Heat Storage in Hot Aquifers” deals directly with HT-UTES. In this project, the objectives are:

- To evaluate the potential risks and benefits of injecting both cooled and heated formation water into warm aquifers, and more specifically to evaluate the possibility of dissolution and precipitation processes in the pore space and the effect on porosity, permeability and mechanical properties of the reservoir.
- To develop novel modelling techniques for monitoring geothermal reservoirs from seismic matching, taking into account well information and general geological knowledge at the same time. The ultimate goal is to assist optimization of future geothermal heat production and storage.
- To quantify the energy budget in a HT-UTES system by modelling.

Both projects supported by DSF are carried out as joint research projects between several Danish research institutions and with participation of international researchers and private companies, amongst others Danish Geothermal District Heating.

A.4.4 Status in other European countries (industrial applications, demonstration activities research and development)

In Europe, one known demonstration project with HT-UTES in a deep reservoir (>1000 m) exists at Neubrandenburg in Germany. In this plant, HT-UTES is performed in the approximately 1250 m deep Upper Postera Sandstone reservoir. The project was initiated in 2004, and hot water of 80 °C is stored in the reservoir which has a virgin temperature of 55 °C. Worldwide, only a few other commercial HT-UTES projects with storage temperatures >60 °C exist in Sweden and Germany, but none of these utilize deep geothermal reservoirs. Similar HT-UTES projects at shallow depth have been conducted in the past but discontinued, including two projects in the Netherlands and one in Sweden. So far, no HT-UTES demonstration projects have been conducted with storage temperatures >80 °C.

Research funded through the International Energy Agency's ECES (Energy Conservation through Energy Storage) programme was carried out in the period 1995-2005 with participation of researchers from Belgium, Canada, Germany, the Netherlands and Sweden. The main outcome of this research is a state-of-the-art report regarding HT-UTES from 1999. Further, the ECES programme gained practical experience with HT-UTES through the aforementioned HT-UTES projects in Germany and the Netherlands.

Presently, HT-UTES using temperatures in the range 40-90 °C is mentioned as one of the strategic research activities under the EU 7th Framework RHC-platform (The European Technology Platform on Renewable Heating and Cooling) but no current activities are reported. Apart from the aforementioned European countries, some research regarding HT-UTES is also performed in France. Of particular interest to Denmark, the French Geological Survey (BRGM) is participating in the HeHo-project mentioned above.

No current projects apart from the Danish HeHo-project deal with HT-UTES at temperatures >100 °C in deep geothermal reservoirs.

A.4.5 Development needs for the technology to become mature for markets

At present, the technology is relatively immature in the sense that HT-UTES has not yet been demonstrated in deep geothermal reservoirs and with storage temperatures >100 °C. Current research in Denmark focus on mapping the geothermal energy potential as well as on possible implications for the reservoirs where HT-UTES may be carried out. Additionally, it is the aim to carry out high performance computer modelling, thereby enabling simulation of reservoir fluid flow and heat flow using a novel approach to geothermal reservoir modelling. Ultimately, the current research will enable formulation of recommendations for a demonstration plant involving heat storage in a geothermal reservoir; i.e. both recommendations with regard to the optimal location as well as recommendations with regard to specific technical challenges and need for pre-investigations may be formulated. If such a demonstration plant is running successfully and the technology seems promising, the market for geothermal heat storage facilities is expected to grow exponentially in Denmark as well as internationally.

In the same time, geothermal energy is an evolving technology in Denmark with possible implementation of several local geothermal plants around the country as well as a large geothermal plant for the city of Copenhagen. Several stakeholders, including local district heating companies, are considering and exploring the application of geothermal energy to partly provide their heat supply to the cities. In this context, preparation for possible HT-UTES in connection with the geothermal plant would be of major importance for later application of HT-UTES in the deep geothermal reservoir utilized by the geothermal plant. In order to initiate such an investment by the district heating companies, the establishment of a successful demonstration plant would also be of major importance.

However, though the current research within the area deals with a large part of the possible technical challenges related to HT-UTES in deep geothermal reservoirs, some future R&D activities are possibly also needed. These may include:

- Reservoir characterization (mineralogical and petrographic composition, formation water chemistry, lateral and vertical porosity-permeability)
- Water treatment technology to prevent clogging of reservoirs, wells, heat exchangers, and pipework due to particles, gas bubbles, precipitation of minerals or bacterial growth
- Component selection to prevent scaling and corrosion
- Thermal efficiency under different geological conditions, including model based design of different storage sites for optimization of storage temperatures as well as reservoir/temperature modelling of heat loss and optimal annual storage amount of heated water under different temperature contrasts between reservoir temperature and injected heated water
- Geochemical and rock mechanical effects in other reservoir types than currently studied

A.4.6 Danish competition position compared to position in other countries

At present, demonstration activities in relation to HT-UTES have not been performed in Denmark. In contrast, several other countries, including Germany, Sweden, and the Netherlands have gained experience with HT-UTES, and one HT-UTES demonstration project in a deep reservoir (1250 m deep) is currently running in Germany. However, in this project hot water is stored at only 80 °C. For comparison, one of the backbones in the Danish development of the technology is the idea to store water at much higher temperatures (up to 200 °C), and the current Danish research focusing on such high temperatures is apparently not duplicated in other countries. Furthermore, Danish experience with operation of geothermal energy plants has been gained since 1984 where the first geothermal plant was established in Thisted. Currently, three geothermal plants are running in Denmark, including the Thisted plant operating since 1984, the Copenhagen plant operating since 2005 and the Sønderborg plant operating since 2013.

The heat supply to approximately 60% of all Danish households comes from district heating and it is estimated that for 80% of these households, geothermal energy supply combined with HT-UTES may be feasible if the technical challenges can be handled in an economically viable way. Therefore, there is a huge potential for making Denmark a forerunner within the development and possible deployment of the technology.

Thus, overall the Danish competition position compared to other countries is considered to be fairly good. However, the technology is not very mature, and strengthening of the Danish position could certainly be obtained via future R&D activities.

A.4.7 SET plan targets for the technology (largely by references)

Currently, there are no specific SET plan targets for the technology. However, HT-UTES is mentioned as one of the possibilities for sensible heat storage in the European Energy Storage Technology Development Roadmap towards 2030.

A.4.8 Actors in Denmark within the topic of the technology

DFG – Danish Geothermal District Heating (in Danish: Dansk Fjernvarmes Geotermiselskab) is a geothermal consultant and participant in the two Danish DSF research projects.

DTU BYG – Technical University of Denmark, DTU Civil Engineering is Project Lead in the “HeHo – Heat Storage in Hot Aquifers” DSF research project.

GEUS – Geological Survey of Denmark and Greenland is Project Lead in the DSF research project “The geothermal energy potential in Denmark - reservoir properties, temperature distribution and models for utilization”, WP Lead in the “HeHo – Heat Storage in Hot Aquifers” DSF research project, and geological-geophysical consultant for all geothermal projects in Denmark.

HOFOR (Greater Copenhagen Utility), CTR (Metropolitan Copenhagen Heating Transmission Company), and VEKS (The Heat and Power Company of Western Copenhagen) are all district heating suppliers that consider HT-UTES in combination with a possible future geothermal plant in Copenhagen.

Sønderborg Fjernvarme and Thisted Varmeforsyning are district heating companies utilizing geothermal energy.

A.4.9 Specific recommendations for the technology in a Danish context

Though the HT-UTES in deep geothermal reservoirs are a relatively immature technology, there is a growing interest in utilizing the technology in Denmark. Specifically at present, several district heating companies are interested in the possibility for energy storage provided by the technology. However, if the technology proves economically and energetically viable, there is a huge potential for including other parts of the energy supply chain in the future.

Current results from the two DSF supported Danish research projects suggest that geothermal energy supply combined with HT-UTES in the deep geothermal reservoir may be technically possible for several of the larger cities in Denmark. A number of geothermal reservoirs with good reservoir quality have been identified, and furthermore, preliminary results from laboratory experiments suggest that, at least on the short term, the reservoir quality will not be affected dramatically by introducing formation water heated to up to 150°C before injection into the tested geothermal reservoir sandstones. In addition, a concept for implementation of the technology, which has been developed by DFG and tested in preliminary reservoir simulations, suggests that in Danish geothermal reservoirs, and following an initial run-in period, the energy loss in the reservoir may ideally be as low as 5-10% in a HT-UTES plant that utilizes deep geothermal reservoirs for heat storage. However, this has not been confirmed by practical examples.

Despite the growing interest in the technology and the promising research results there is, however, need for a proof-of-concept in order to kick-start the deployment of the technology because the investment in a geothermal plant with HT-UTES facilities is rather large compared to the budget of a typical Danish district heating company. Thus, in a Danish context, the main catalyst to initiate the deployment of the technology will be to establish a successful demonstration plant. Establishment of such a plant would include a variety of tasks such as exploration drilling and coring, pump-tests, laboratory experiments, and numerical simulation of formation pressure, heat flow, etc. Such a demonstration plant could very well be established in combination with the possible large future geothermal plant in Copenhagen.

In the above context, it is in short recommended that:
Attention is paid to the results and recommendations deriving from the ongoing DSF research projects

If the results from these projects prove promising, establishment of a demonstration plant with HT-UTES in deep geothermal reservoirs should be supported
Further R&D related to the technology and the heterogeneity of the potential reservoirs not covered by the current DSF projects should be supported

A.5 Aquifer Thermal Energy Storage (ATES)

A.5.1 Short technology description

Aquifer Thermal Energy Storage (ATES) is a low temperature Underground Thermal Energy Storage (UTES) technology which functions as a seasonal storage of cold and heat⁴³. The aquifer is accessed by two wells or multiples of two wells (typically) and screened in the same groundwater aquifer. In the winter, cooled water from a heat exchanger (or a heat pump) is pumped into the cold well, while heated water from the aquifer is abstracted from the other well and provides a heat source for the heat exchanger (or the heat pump). In summer, the process is reversed and cold water is abstracted for cooling. The warm water from the heat exchanger (or heat pump) is returned to the warm well. Hence groundwater circulates in a loop, and there is no consumption of groundwater.

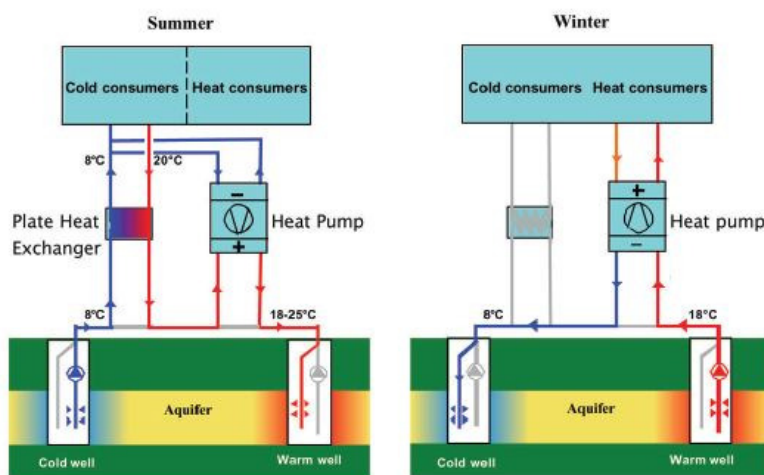

Figure 1 Example of an ATES well and equipment configuration¹³.

ATES systems typically operate at low temperatures between a few °C and 25 °C and a delta temperature of around 10 to 12 °C. At such low temperatures and ΔT changes the risk of both fouling and scaling due to mineral dissolution and precipitation is minimal, when plants are well constructed. In Denmark legislation demands that the temperature of the heated groundwater injected to the aquifer (e.g. during summer) doesn't exceed 25 °C and that the monthly average doesn't exceed 20 °C. In Denmark it is a prerequisite for a permit to construct an ATES plant that the heat transferred to the aquifer over time is balanced by re-cooling of the aquifer⁴⁴.

A.5.2 Short technical and economic status

Aquifer Thermal Energy Storage is basically a market mature technology and has internationally been commercially available for several decades⁴⁵. The first use of ATES took place in China in the 1960s storing cold from winter for cooling purposes in the textile industry in shallow aquifers. In Europe the first ATES plants were in production in the Netherlands in the late 1980s¹³.

The construction of an ATES plant is, however, not an easy task. It demands skills in geology and aquifer hydraulics in the exploration for suitable high yielding aquifers, and in the design and

⁴³ Halozan, H., 2010: Ground-Source Heat Pumps for Commercial Buildings. Ground-Source Heat Pumps for Commercial Buildings. Vol. 28, no. 1.

⁴⁴ Miljøministeriets bekendtgørelse nr. 1206 af 24. november 2006: Bekendtgørelse om varmeindvindingsanlæg og grundvandskøleanlæg.

⁴⁵ European Energy Storage Technology. Development roadmap towards 2030. Joint EASE/EERA recommendations ES Technology Development Roadmap.

construction phase knowledge of geochemistry, thermodynamics and HVAC engineering to get an optimal ATES operation tailored to the actual need for heating and cooling.

The main challenges and risks associated with the technology are related to the geological uncertainties since quite high yielding aquifers are needed and not always present. Hence an exploration phase is needed where the "aquifer storage resource" is verified. Parallel to this, a time consuming permitting process has to be conducted. Such a permit to use an aquifer for heat and cold storage purposes cannot in advance be taken for granted, and an application has to include detailed information from geological investigations and numerical modelling documenting that the ATES plant will not be a threat to current or future abstraction of groundwater for water supply purposes^{46, 47}. In the operation phase the main problems are associated with the risk of clogging of heat exchangers and injection wells by iron oxides or the risk of mobilization of fines from the pumping well to the injection well also causing clogging.

The investment in an ATES plant can normally be justified solely by the need for cooling. In table 1 the investment in a 1 MW ATES plant for cooling is compared with more traditional cooling technologies. Comparable cost estimates are given in ⁴⁸ and ⁴⁹.

Technology	Investment (mio. DKK/MW)	Production cost (DKK/MWh)
Dry cooling	6,0	658
Dry cooling w. heat recovery	6,0	140
Aquifer Thermal Energy Storage	5,1	50

Table 1. Figures based on 2011 concept study by Rambøll A/S done for Copenhagen Energy (today Høfor A/S). Production costs are based on an aquifer having hydraulic characteristics commonly occurring in Denmark⁵⁰.

The investment in an ATES plant is a bit lower than investment in traditional dry cooling and as shown, if suitable geological conditions are present, aquifer storage plants are highly profitable and often have a payback time of less than 3-5 years ⁵¹ and ⁵².

Technology Readiness Level

Pilot level			Demonstration level			Market mature		
					X	X		

A.5.3 Technology status in Danish industry and research community

There has been almost no research in low temperature Underground Thermal Energy Storage in Denmark (ATES) to support the introduction in Danish energy supply. The technology was introduced to the Danish market by a niche service company Enopsol Aps (at that time "Energi og

⁴⁶ Miljøministeriets bekendtgørelse nr. 1206 af 24. november 2006: Bekendtgørelse om varmeindvindingsanlæg og grundvandskøleanlæg

⁴⁷ Vandplan Sjælland 2000: Miljømæssige konsekvenser af akvifer kulde- og varmelagring. Rapport udarbejdet af HOH Vand & Miljø A/S (i dag Rambøll).

⁴⁸ European Energy Storage Technology. Development roadmap towards 2030. Joint EASE/EERA recommendations ES Technology Development Roadmap.

⁴⁹ Energistyrelsen 2013: Udredning vedrørende varmelagringsteknologier og store varmepumper til brug i fjernvarmesystemet. Udarbejdet af PlanEnergi, Teknologisk Institut, GEO og Grøn Energi.

⁵⁰ Københavns Energi 2011: Kølning af Nye Bydele. Rambøll Danmark A/S.

⁵¹ Halozan, H., 2010: Ground-Source Heat Pumps for Commercial Buildings. Ground-Source Heat Pumps for Commercial Buildings. Vol. 28, no. 1.

⁵² Energistyrelsen 2013: Udredning vedrørende varmelagringsteknologier og store varmepumper til brug i fjernvarmesystemet. Udarbejdet af PlanEnergi, Teknologisk Institut, GEO og Grøn Energi.

Miljøteknik Aps") back in the 1990s based on mainly Dutch and Swedish research and experiences. As there were no regulatory guidelines on ATES at that time, the Danish counties had a review report prepared, based on mainly Dutch and Swedish research and practical experiences with ATES. The review report resulted in guidelines and recommendations on how to construct and operate ATES plants in an environmentally safe way, where the main environmental concerns were (and still are) to safeguard groundwater for drinking water purposes⁵³. A few years later, the review report from 2000 resulted in a Government Order covering construction and operation of ATES plants⁵⁴. Thus, the environmental regulations needed, to protect the groundwater from a negative impact from ATES, are in place. At the same time, the current legislation will prevent injection at medium-high temperatures, i.e. above 20-25 degree C.

Although the ATES technology is well known there are only a small number of plants in Denmark despite the very obvious economic benefit (and CO2 emission reduction potential) and, in large parts of the country, favourable hydrogeological conditions. It is estimated, that around 30 to 40 ATES plants have been constructed in Denmark (defined as plants where all groundwater is re-injected to the aquifer). A list of 21 plants is presented in ⁵⁵. The total capacity of these 21 plants is 42 MW. Most investments in ATES plants are motivated by the need for cooling and the economic benefit mainly comes from cost savings compared to traditional cooling (typically > 70 %). When also heat is needed during wintertime another c. 40-60 % cost savings compared to traditional heating can be achieved, depending, however, on the type of traditional energy source the ATES plant replaces. If heat cannot be reused, the cooling capacity of the aquifer is re-established by re-cooling of the aquifer during wintertime. Thermal balancing of the aquifer is also in most cases a precondition for the operating permit.

So far Danish ATES plants are predominantly established as individual, mainly privately owned plants with a capacity of around 0,5 to 5 MW with a cooling COP of 50 to 60 and a heating COP of 4-5. The early plants were mainly serving a need for cooling in the industry, whereas later plants typically are constructed to supply both cooling and heating in large buildings.

A.5.4 Status in other European countries

In Europe, the main application of ATES takes place in Sweden, The Netherlands (NL), Belgium and Germany with NL as the by far most prominent user of the technology and where funds have been available for research. Dutch research in low temperature storage in aquifers took off after initial research failures with high temperature storage in e.g. Denmark and Switzerland (supported by IEA) in the period 1985 – 1995 ⁵⁶.

⁵³ Vandplan Sjælland 2000: Miljømæssige konsekvenser af akvifer kulde- og varmelagrings. Rapport udarbejdet af HOH Vand & Miljø A/S (i dag Rambøll).

⁵⁴ Miljøministeriets bekendtgørelse nr. 1206 af 24. november 2006: Bekendtgørelse om varmeindvindingsanlæg og grundvandskøleanlæg.

⁵⁵ Grundvandskøle- og varmeanlæg (ATES). Status og erfaringer, Niemi Sørensen, S., 2011, ATV Jord og Grundvand, Vintermøde og jord- og grundvandsforurening. Vingstedcentret

⁵⁶ Snijders, A. L., Aquifer Thermal Energy Storage in the Netherlands. Status beginning of 2005.

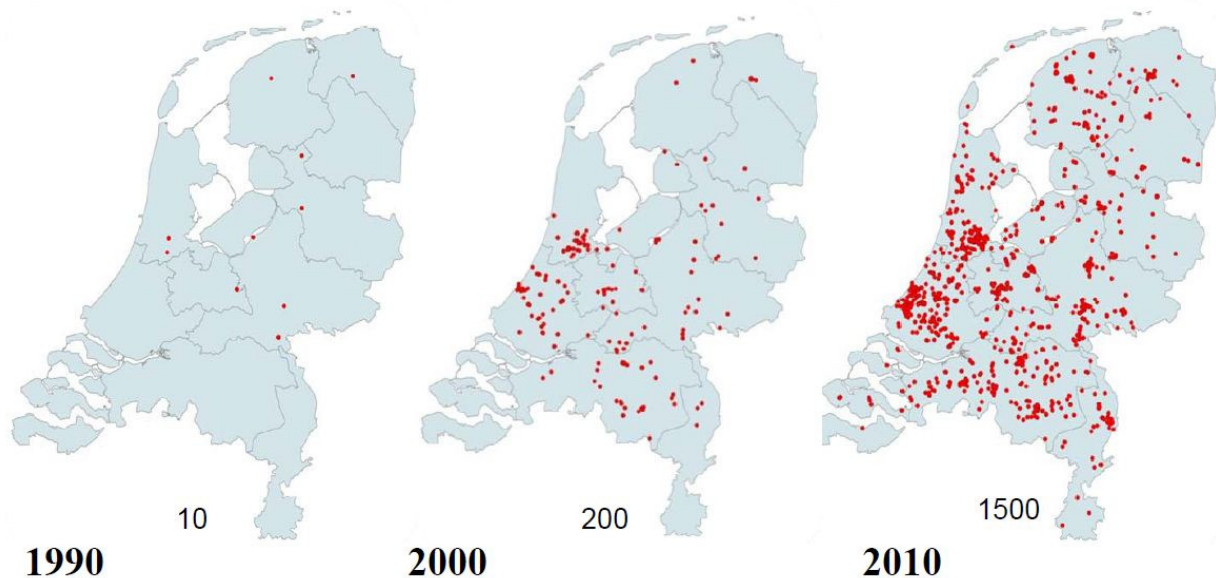

Figure 2. Number of ATES in the Netherlands⁵⁷

Figure 2 tells the impressive story of ATES development in The Netherlands. The huge success of ATES in NL is to a large extent the result of very favourable geological conditions for ATES. The country is literally situated on top of a number of stacked, high yielding aquifers reducing the geological risk for failure to practically zero⁵⁸. The total capacity of ATES plants in NL were c. 1 GW in 2007 according to⁵⁹.

The speed of ATES construction in NL is foreseen to continue due to the low risk and high profit of an ATES plant. The Dutch authorities give licenses on a first-come, first-served basis and most plants are individual plants where the ATES capacity is invested in and used independent from any collective energy supply in the area. The so far individual character of the plants represents the flip side of the technology in NL. More effective use of the subsurface storage capacity must be promoted to avoid that every individual property owner is going to build a separate installation which could cause unwanted interactions between plants⁶⁰. The Dutch parliament has in 2010 decided that more regulation will be provided by central and local authorities to (re)optimize the use of the underground with respect to thermal storage. This will include stimulation of large-scale projects rather than smaller scale ATES systems. The intention is to have about 18,000 ATES systems by 2020. This goal requires new regulations and legislation for optimal underground planning.

In Amsterdam the water utility company Waternet has set up a district cooling company aimed at creating synergy between the various energy sources, distribution systems and ATES storage capacity⁶¹. The prerequisite for success is to a large part, that the (remaining) ATES capacity is reserved for the collective supply companies.

⁵⁷ Snijders, A. L., Aquifer Thermal Energy Storage in the Netherlands. Status beginning of 2005.

⁵⁸ Vandplan Sjælland 2000: Miljømæssige konsekvenser af akvifer kulde- og varmelagring. Rapport udarbejdet af HOH Vand & Miljø A/S (i dag Rambøll).

⁵⁹ Halozan, H., 2010: Ground-Source Heat Pumps for Commercial Buildings. Ground-Source Heat Pumps for Commercial Buildings. Vol. 28, no. 1.

⁶⁰ Gotschalk, M. S. & Bakema, G., 2009: 20,000 ATES Systems in The Netherlands in 2020 – Major step towards a sustainable Energy supply. Proceedings of the Effstock conference in 2009.

⁶¹ Jensen, T.F., Hvid, J. & Haaning, N., 2011: Aquifer Thermal Energy Storage (ATES) – Et nyt redskab i den kollektive energiforsyning. ATV Jord og Grundvand. Undergrunden som termisk ressource.

A.5.5 Development needs for the technology to become mature for markets

As mentioned in section 1.5.2 the ATES technology is considered a market mature technology. The various basic plant configurations are well known and the same accounts for the plant operations. Still, only a few plants are constructed in Denmark. Despite the potentially high profitability of an ATES plant, the risks and other barriers seem to prevent a lot of investors from investing in ATES. The main reasons probably being:

- The risk of not getting a permit
- The geological risk of not finding a sufficiently high yielding aquifer in the area of interest
- A time consuming test period and permitting procedure

The risk of not getting a permit and the geological risk can be evaluated very early in the decision process and can in most cases be done as a fast desk top study. If then, conservative thermal aquifer modelling, based on assumed aquifer parameters, is carried out, and documents no or limited thermal influence of water wells (< 0,5 °C in water abstraction wells), there are, however, no reasons for authorities not to issue a permit for an ATES plant. p

A time consuming test and permitting process, taking a year or more, can hardly be avoided, but since such an extension of the time schedule is often not acceptable in most building projects this will often (together with geological risk) cause decision makers/owners to avoid ATES, also in areas where the geological conditions are actually favourable.

A.5.6 Danish competition position compared to position in other countries

Denmark holds a weak position on the international market for ATES plants per se. However, if concepts for ATES integration with district heating and district cooling are developed it might be possible to profit on the international market from Denmark's high reputation on district heating and the foothold gained on this market internationally.

A.5.7 SET plan targets

Currently, there are no specific SET plan targets for the technology and ATES as sensible heat storage technology has only attracted minor attention in the European Energy Storage Technology Development Roadmap towards 2030⁶².

A.5.8 Actors in Denmark!

Enopsol A/S, GEO A/S as consultants and contractors

Brøker A/S as drilling contractor

GEUS as research institution

Grontmij A/S, COWI A/S, Moe A/S, Niras A/S, Rambøll Danmark A/S as consultants

Heat Pumps, Heat exchangers, Pumps, Control Systems: Several

A.5.9 Specific recommendations for the technology in a Danish context

For ATES to become a success in Denmark the technology has to have a more prominent position in the mind of authorities, energy planners, consultants and building architects. To reach such a position, municipalities should include ATES in their municipal energy planning and water supply planning and Municipalities with an ATES potential should be obliged to plan for the efficient use of the potential. Furthermore, cooperation and coordination between water and district heating utility companies will be of paramount importance and should be facilitated in the legislation.

If ATES in advance are considered an option in the energy planning (e.g. the integration of ATES in new buildings, or as part of the total energy supply concept in new areal development projects

⁶² European Energy Storage Technology. Development roadmap towards 2030. Joint EASE/EERA recommendations ES Technology Development Roadmap.

like Nordhavnen in Copenhagen), it would be possible to plan for a longer permit, test and construction period than for conventional dry cooling, and its successful integration would be more likely.

In Denmark ATES plants are established on a first-come, first-served basis as in most other countries. The disadvantage is that the individual ATES plants are not necessarily integrated in the energy supply structure in the most coherent, energy efficient and socio-economic favourable way. Also this first-come, first-served principle makes it impossible to plan for the most efficient use of the potential energy storage capacity of a given aquifer.

It is recommended that water and district heating utility companies should be given the possibility of investing in ATES and in independent district cooling companies. This would demand new legislation. According to current legislation district cooling companies can only be founded by commercial companies and without access to municipal financial support or guaranties. This restriction is justified by the perception that district cooling (contrary to district heating) isn't a public benefit to all citizens. However, for ATES plants both the heating and cooling are to some extent of equal standing. Therefore it can be justified that municipalities are given legal access to invest in district cooling and hence ATES.

As wind power becomes dominant in Danish power supply (50% from 2020), heat pumps and energy storage will play an important role in the main energy supply system. As a cooling technology, ATES reduces the summer peak electricity loads hence reduces risk of power system instability. As a source of heating, ATES offers the opportunity to substitute fossil fuels for heating by wind generated electricity via heat pumps. After the reduction in electricity taxes for heating, ATES for heat production has become considerably more viable from a financial point of view. In order to tap these potential benefits, the ATES potential should (as previously mentioned) be integrated into the municipal heat planning following the principles of maximizing the socio-economic and environmental benefits laid out in the current heat planning legislation. This would encourage the use of ATES in ways best possibly suited to the local conditions, including local demands for cooling and heating, annual load distribution of cooling and heating etc. The optimum use of ATES would often involve both heating and cooling. In order to secure an efficient integration of these two types of energy supply, district heating utilities should be given access to also supply cooling at least to the extent that this would increase the total economic and environmental benefits.

Individual ATES plants should be prohibited in areas where there is collective district heating and where district cooling is planned for.

The potential for CO₂ emission reduction by ATES is estimated in ⁶³ /10/ to be 220.000 tons. If ATES is fully integrated in collective energy supply in the best possible way, it is our evaluation (supported by the Dutch experiences), that a much larger figure can be achieved. Individual ATES plants should be prohibited in areas where there is collective district heating and where district cooling is planned for.

The potential for CO₂ emission reduction by ATES is in the same reference estimated to be 220.000 tons. If ATES is wise fully integrated in collective energy supply it is our evaluation (supported by the Dutch experiences), that a much larger figure can be achieved.

⁶³ Grundvandsvarmepumper og -køling med grundvandsmagasiner som sæsonlager. Enopsol ApS, DONG Energy A/S, Hundsbæk & Henriksen A/S, Cenergia ApS, SBI, 2007. Elforsk PSO-F&U.

A.6 Borehole Thermal Energy Storage

A.6.1 Borehole thermal energy storage (BTES) Short technology description

Borehole thermal storages have been developed and demonstrated e.g. in Sweden, Germany and Canada. Recently a 19,000 m³ pilot plant has been implemented in Denmark. The principle of the storage is to heat up soil and cool it down again. This is done in a closed system with vertical boreholes (30-100 m deep) filled with one or two plastic pipes and grouting. The distance between the boreholes is app. 3 m.

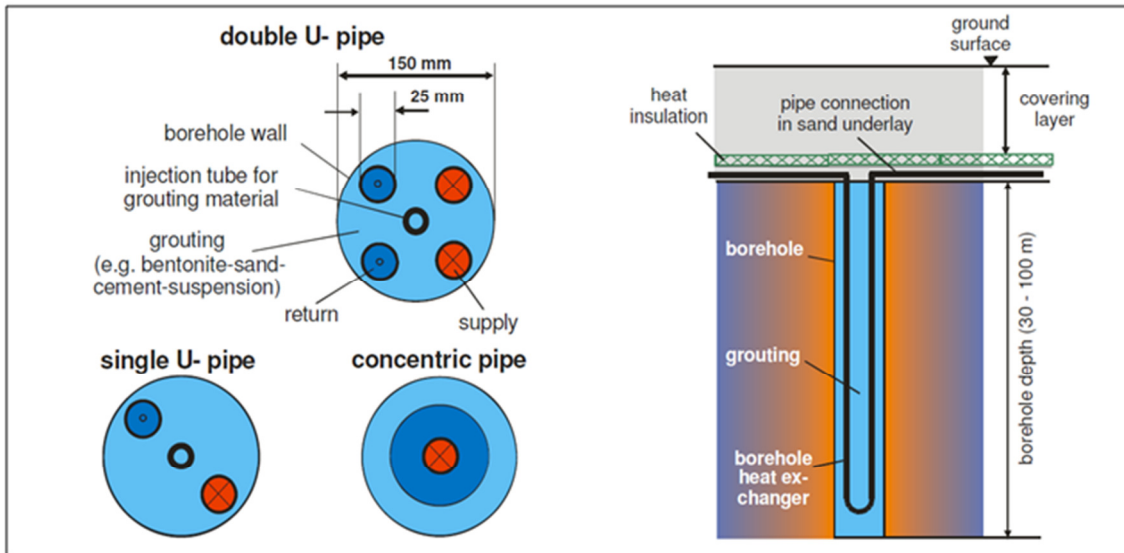

Fig. 1: Usual types of borehole “heat exchangers” and part of a borehole storage⁶⁴

In future energy systems BTES can be used to store low temperature (up to 90 °C) excess heat from industries, incineration plants and heat from renewable energy sources such as solar thermal for use in district heating. Also BTES can integrate heat from heat pumps, solar thermal and CHP plants in combined energy systems utilising power to heat (heat pumps) in periods with excess electricity production and store heat from periods with need for electricity production from CHP.

A.6.2 Short technical and economical status

The first Danish pilot plant (19,000 m³) has been implemented at Brædstrup Fjernvarme in 2011-12. The design is in principle a copy of the Crailsheim plant in Germany but the connection of the pipes and construction of the covering layer is different.

⁶⁴ Large scale heat storage. T. Schmidt, D. Mangold, P.A. Sørensen og N. From. Conference paper, IRES 2011, Berlin

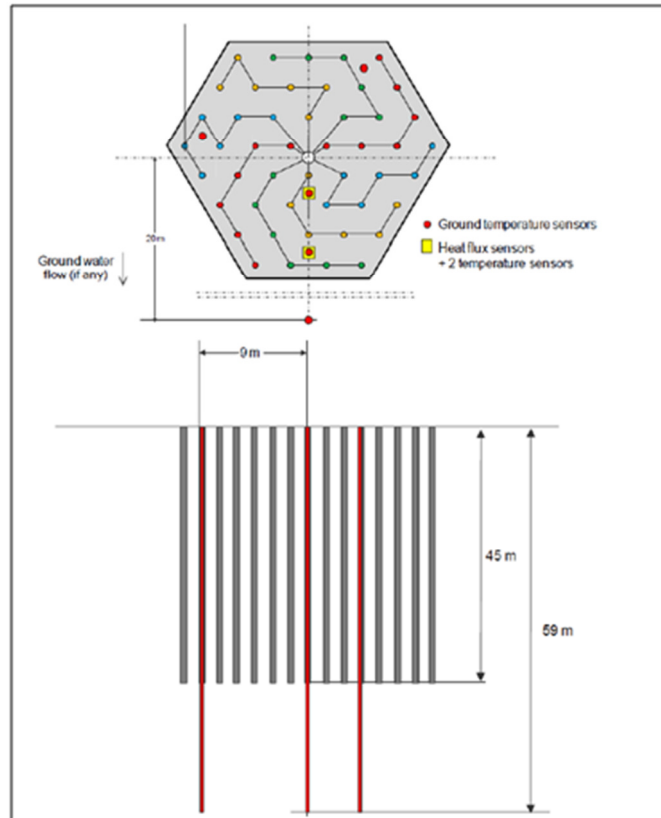

Fig. 2: Layout of the borehole storage in Brædstrup⁶⁵

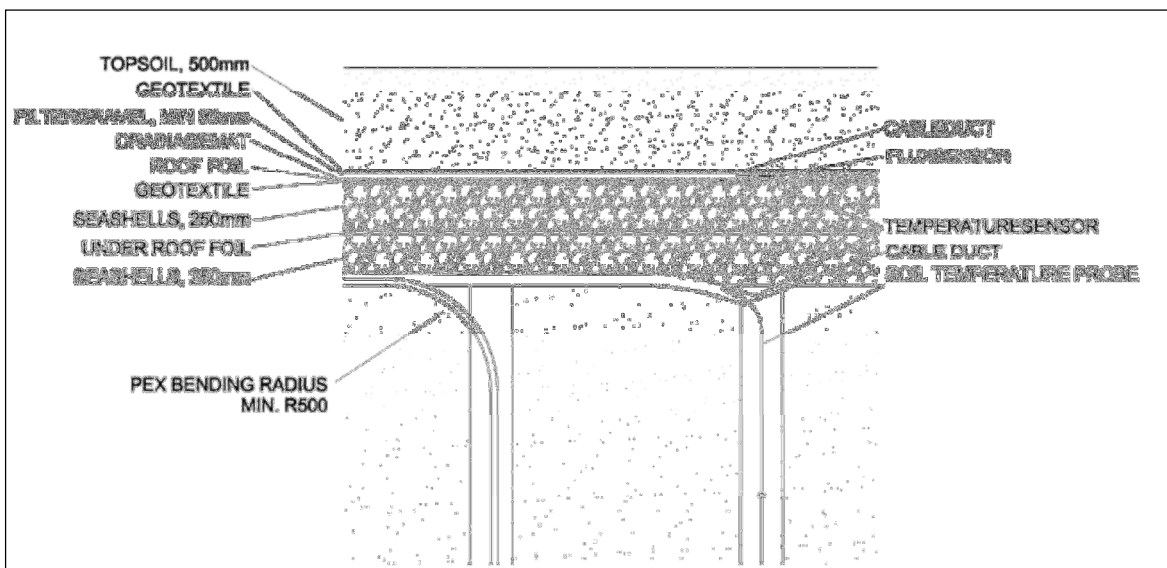

Fig. 3: Covering layer in Brædstrup¹⁶

Data for the storage in Brædstrup

- Built 2011-12
- Size: 19.000 m³ earth
- Price 270.000 € excl. Transmission pipe and buffer tank or 0.43 €/kWh

⁶⁵ Two approaches of seasonal heat storing. Pit heat storage and borehole thermal energy storage. Morten V. Jensen og Niels From, PlanEnergi. Conference paper, 1st SDH conference, Malmø 2013.

- Temperatures 10-70° C
- Capacity (calculated) 630 MWh
- Charge and discharge capacity 300 – 600 kW
- Calculated heat loss: 148 MWh 1.st year

Technology Readiness Level

Pilot level			Demonstration level			Market mature		
		X	X					

A.6.3 Technology status in Danish industry and research community

Development of the pilot BTES design in Brædstrup has taken place in co operation between SOLITES from Germany, PlanEnergi, GEO, Via University, Horsens, Brædstrup Fjernvarme and suppliers.

The design seems to function as calculated and if monitoring results from the first couple of years are satisfying a full scale demonstration plant will be the next step in Brædstrup.

Probes with PEX-pipes and grouting have been delivered from Germany, but all construction work has been done by Danish entrepreneurs.

In Denmark there are currently 337 boreholes made for ground source heating of dwellings and family houses⁶⁶. The majority of these boreholes are fit for BTES with an appropriate connection to solar panels or other energy absorbers using well known components and services from Danish Industry. The principle of a local BTES are shown on the below Figure:

Inclined boreholes with heat pump and accumulation tank.
 Solar heats on ground, storage of surplus solar heat in boreholes.
 Partly radiators and partly floor heating.

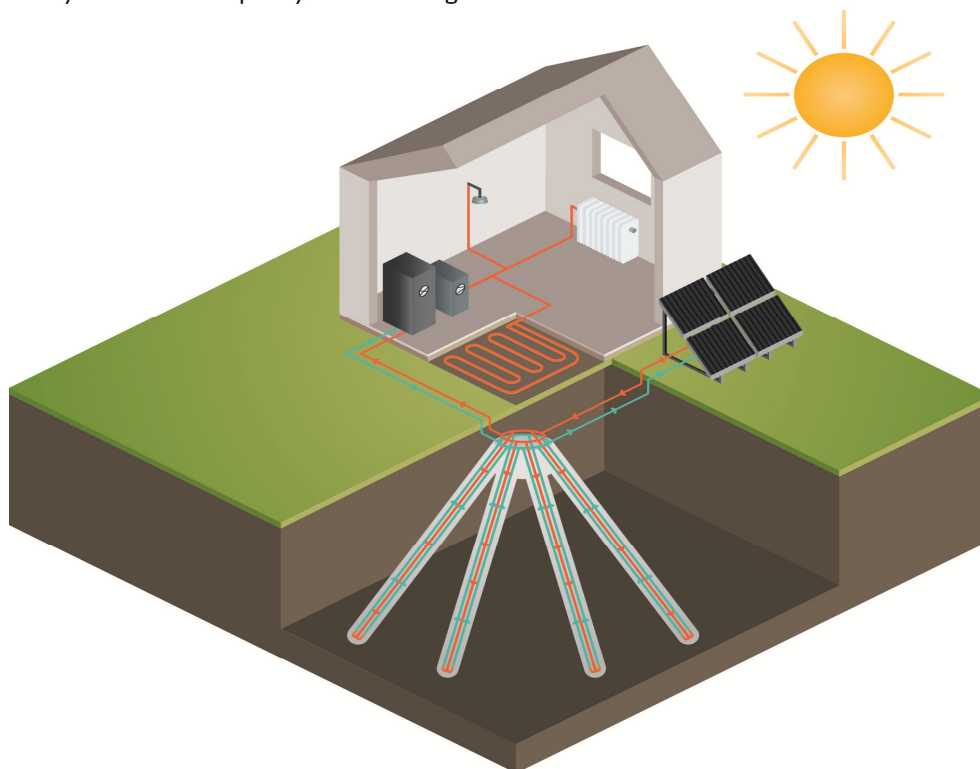

⁶⁶ <http://data.geus.dk/JupiterWWW/index.jsp>

A.6.4 Status in other European countries

Technology for vertical drilling for heat pump pipes is utilized for borehole storages as well. Germany and Sweden are leading in this technology, but for borehole storages the pilot plant design in Brædstrup seem to be competitive to the two demonstration plants in Germany and the one in Canada.

Plants in Sweden are made in rock and special kinds of clay and are not comparable to the Danish conditions.

Thus only a few relevant demonstration plants are implemented outside Denmark (Two in Germany and one in Canada).

A.6.5 Development needs for the technology to become mature for markets

- Monitoring of the pilot plant in Brædstrup.
- Attention on existing boreholes for ground source heating – some of them have installed facilities for BTES
- Experiences with cheaper drilling of boreholes.
- Full scale demonstration plant.
- Demonstration plant in water filled clay.

A.6.6 Danish competition position compared to position in other countries

Danish companies are competitive but soil conditions differs very much from country to country and thus local companies will normally be most competitive in geological investigations and drilling of boreholes.

A.6.7 SET plan targets for the technology

No targets found.

A.6.8 Stakeholders in Denmark within the topics of the technology

Geotechnical investigations: GEO

Drilling: Several

Import of probes / production of probes: ROTEX

Pipes in boreholes: Wawin

Cover building: several

Control system: several

Consultancy: PlanEnergi

Education: VIA University College, Horsens

A.6.9 Specific recommendations for the technology in a Danish context

Integration in smart energy systems as for PTES and demonstration in centralized CHP systems as for PTES.

A.7 Pit Thermal Energy Storage

A.7.1 Pit thermal energy storage (PTES) Short technology description

Pit thermal energy water storages have been developed in Denmark from the beginning of the 80ties. Danish Technical University (DTU) developed the storage type and implemented small test storage at the University campus.

The first pilot storage (1,500 m³) was implemented in 1995 and Danish demonstration storages has been implemented in 2004 (10,000 m³), 2011-12 (75,000 m³) and 2013 (60.000 m³). The principle of the storage is very simple.

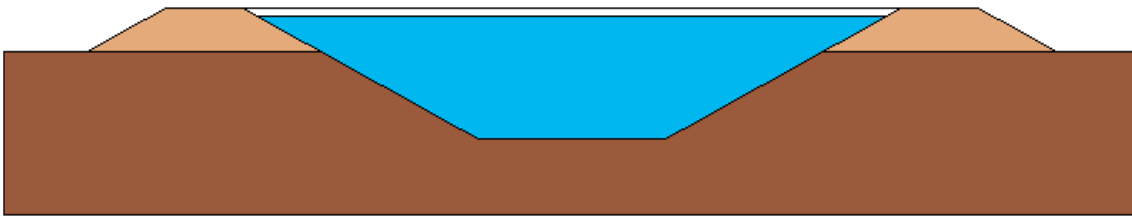

Fig. 1: Cross section of PTES

In an area preferably with ground water below 15 meter a hole is excavated and the surplus soil placed as banks for the storage. Side and bottom is covered with a 2.5 mm welded HDPE-liner and the lid is an insulated construction with a 2 mm HDPE liner floating on the water and following the changes in water level.

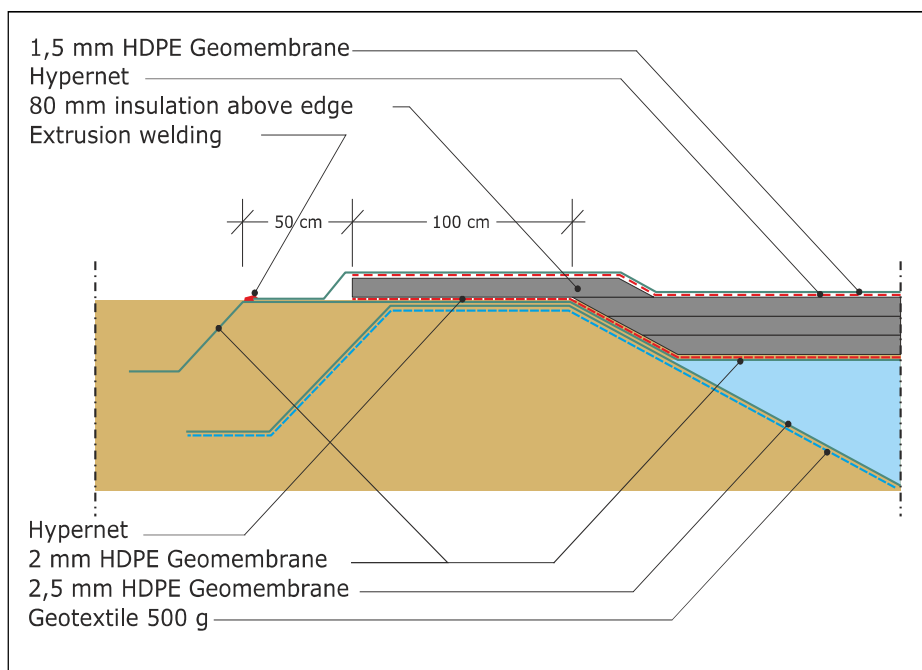

Fig. 2: Construction of lid⁶⁷ In- and outlet is in top and bottom and in the middle of the water column.

⁶⁷ SUNSTORE 4. Deliverable 2.2. Design of the pit heat storage. PlanEnergi, 2013

In future energy systems PTES can be used to store excess heat (up to 90 °C) from industries, incineration plants and heat from renewable energy sources such as solar thermal for use in district heating. Also PTES can integrate heat from heat pumps, solar thermal and CHP plants in combined energy systems utilising power to heat (heat pumps) in periods with excess electricity production and store heat from periods with need for electricity production from CHP.

A.7.2 Short technical and economic status

In principle a design of the storage exists and has been demonstrated, but some details need still to be further developed and tested. The HDPE-liner shall be able to resist 90°C in 20 years and the insulation in the lid must be protected against condensation inside the material. Also new and cheaper lid constructions can be developed. The expected price curve of the storage is shown in Figure 3.

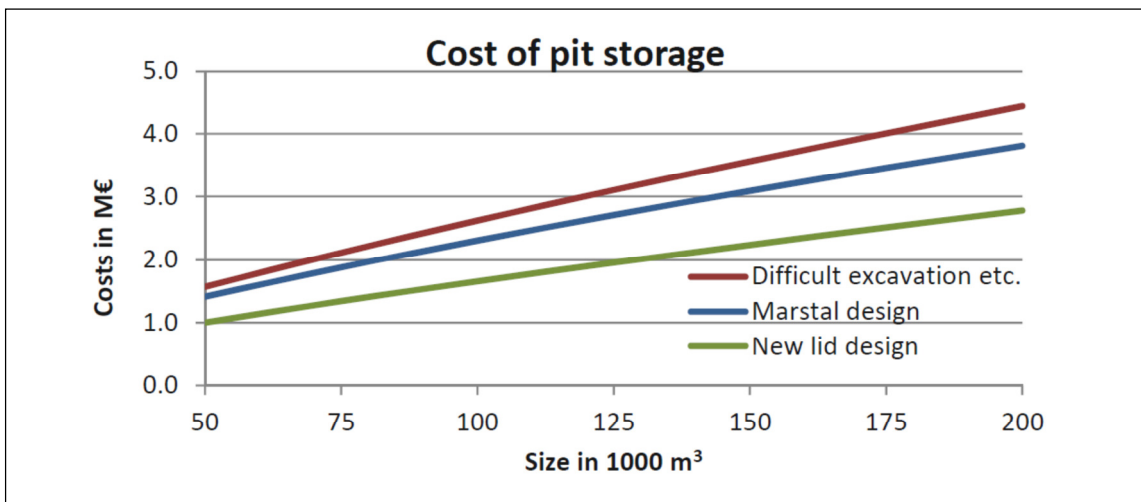

Fig. 3: Price curve for PTES⁶⁸

The red and blue curves are present calculated prices. The green curve expected prices in 2020. Data for the 75,000 m³ storage in Marstal is:

- Built 2011-12
- Size: 75,000 m³ water
- Price 2.65 mio. € excl. transmission pipe or 35.5 €/m³ or 0.373 €/kWh
- Temperatures 10 – 90° C
- Capacity: 6,960 MWh
- Charge and discharge capacity: 10.5 MW
- Calculated heat loss: 2,475 MWh/year

Technology Readiness Level

Pilot level			Demonstration level			Market mature		
					X	X		

A.7.3 Technology status in Danish industry and research community

Development of the Danish PTES design has taken place among district heating companies (primarily Marstal), consultants (PlanEnergi and SOLITES) and Suppliers (GSE and PBJ Consult).

⁶⁸ Solar District Heating Guidelines. Fact sheet 7.2. www.solar-district-heating.eu

SOLITES (German company owned by Steinbeis Foundation) is responsible for monitoring. No Danish research institutes are at present involved in the total design. Danish Technological Institute has tested liners used in Marstal.

Danish suppliers are involved in import of liner, excavation, welding of liner, welding and implementation of lid, production and implementation of in- and outlet and supply of connection pipes, heat exchangers, pumps, valves and control system.

A.7.4 Status in other European countries

Outside Denmark PTES are built in Sweden and Germany. The Swedish storages are from the 80ties and no longer in operation. The German storages are often made of concrete with a steel liner inside or with water/gravel inside so that a fixed lid can be implemented. Prices are higher than in Denmark.

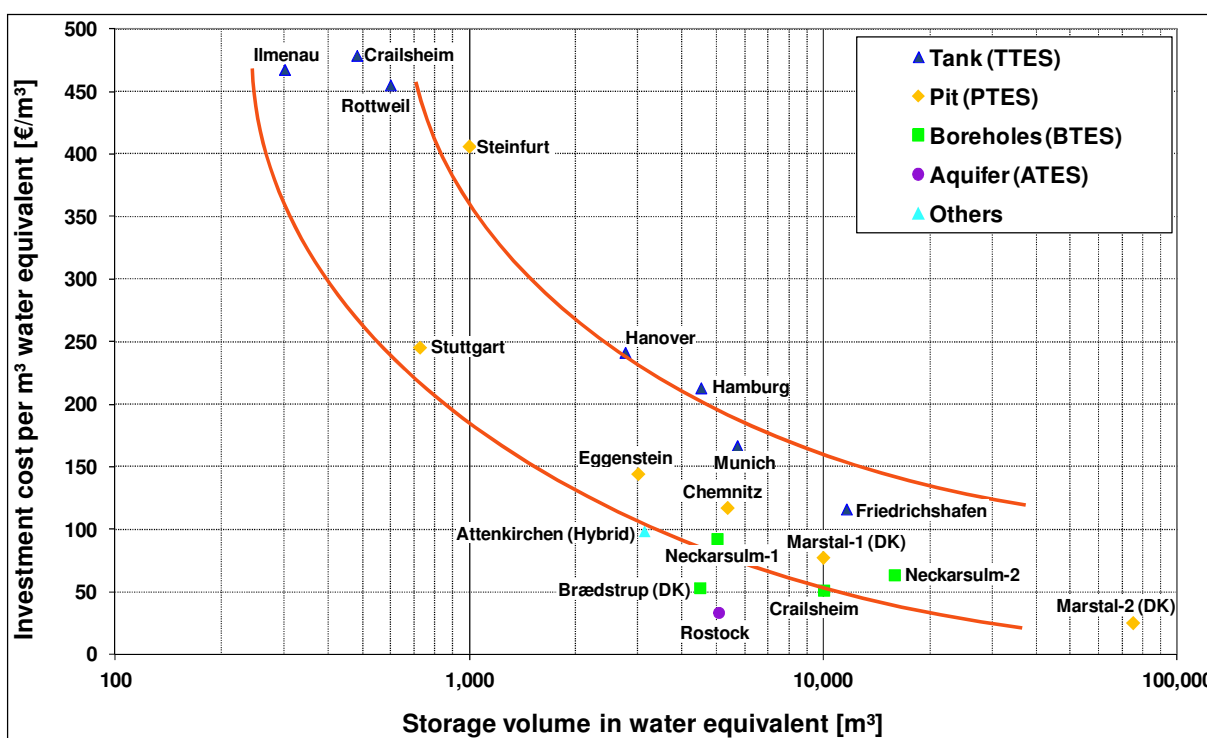

Fig. 4: Storage costs in DK and Germany⁶⁹

A.7.5 Development needs for the technology to become mature for markets

- Test of life time of liners.
- Test of life time and ventilation of lid constructions.
- Reliable monitoring results for demonstration plants.
- Demonstration of (larger) storages.
- Cheaper stores e.g. by use of existing infrastructure (gravel pits, dry docks from closed shipyards)
- Storage technologies for new purposes (surplus heat from industrial processes, incineration plants)
- Demonstration of cheap storages for low temperature purposes (below 50 oC)

⁶⁹ Large scale heat storage. T. Schmidt, D. Mangold, P.A. Sørensen og N. From. Conferencepaper, IRES 2011, Berlin

A.7.6 Danish competition position compared to position in other countries

Since only DK has developed this cheap type of storage there is no competition at present. But the storage concept seems until now not to be acceptable in Germany because of the floating cover, so there are barriers. Also the concept is easy to copy.

A.7.7 SET plan targets for the technology

No targets found.

A.7.8 Stakeholders in Denmark within the topic of the technology

Import of liners: John Hunderup

Excavation: Several

Welding of liner: PBJ Miljø

Implementation of lid: PBJ Miljø

In- and outlet: Several

Connection pipes, heat exchangers: Alfa Laval, SONDEX

Pumps: Grundfos, Desmi

Valves: Broen

Control system: Several

Consultancy: PlanEnergi, Niras, Rambøll, GEO (geotechnical consultancy)

A.7.9 Specific recommendations for the technology in a Danish context

Demonstration of how to integrate large heat stores in smart energy systems, where the heat storage can provide flexibility to the heating system, move surplus heat from summer to autumn and winter and offer heat storage for "power to heat" from heat pumps and electric heaters.

Heat storage integrated in the Danish central CHP systems is of high importance.

A.8 Thermal energy storage – non-water based materials

Worldwide heat demand accounts for almost 50% of the World's final energy demand⁷⁰ and in Denmark the fraction is even higher. Furthermore, in Germany 85 % of the energy consumed by households is used for space heating and sanitary water heating⁷¹ and again the fraction in Denmark is on a similar level. Thus heating plays a dominating role in the Danish energy system and Thermal Energy Storage (TES) will become an important factor for efficient generation, supply and distribution of heat where heat supply and demand do not match in time or space. Effective thermal management within heating/cooling, process heat, power generation and optimized utilization of renewable energy supply investments. Attractive features of TES systems are a broad spectrum of available temperatures and power levels as well as a multitude of technologies to transfer heat from one reservoir to another. Every individual application of energy in the form of heat or cold requires specific levels for temperature, power and energy capacity and therefore availability of a diverse spectrum of technologies and system designs is needed in the future energy system of Denmark.

A.8.1 Thermal energy storage – short technology description

Basically 3 types of thermal energy storage exist:

- Sensible Heat Storage (SHS)
- Phase Change Materials (PCM) for heat storage
- Thermochemical heat storage (TCS)

By storage of heat using **sensible heat storage** the temperature of a material is increased by addition of heat. In this way heat is stored in the material and the storage properties depend on the material's heat capacity as well as thermal insulation of the system. The technology is well known from hot water tanks in residences.

By storing heat using **Phase Change Materials** a material is subjected to a phase change induced by addition of heat. If the phase change is associated with heat of transformation (which is the case for most phase changes) heat is stored in the transformed material and can be released by the reversed transformation. Storage properties depend on the heat of transformation and thermal insulation.

By storing heat using **thermochemical heat storage** a reversible chemical process involving change of system enthalpy is utilized. An example of a practically usable reaction is metal hydride splitting/formation and is illustrated by the following equation:

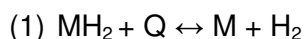

where Q is the heat required to dissociate the hydride (the hydride splitting is an endothermic process). For systems like this storage capacity depends on the involved enthalpy change but losses over time are reduced to zero if the reversed process is prevented simply by isolating the evolved gas by a valve. The heat can then be regenerated by opening the valve and thereby allowing the reversed reaction of (1).

Indicative numbers for heat storage density of the above mentioned storage technology classes are 1:2:5, but large deviations can be found for individual materials and systems.

⁷⁰ <http://www.iea.org/topics/heat/>

⁷¹ Deutsche Energie-Agentur (dena) und Energiedaten BMWi, 12/2011

A.8.2 Short technical and economic status

Sensible heat storage in water is strongly established in Denmark both from a user's and from a supplier's point of view. The technology is widely used in households and district heating systems and industrial suppliers of storage units and systems are found in Denmark.

Apart from sensible heat storage in water and passive storage in building elements, thermal energy storage is not used to any substantial extent in Denmark.

Commercial PCM products are used (cited from ⁷²) for insulated transport containers (e.g. medical applications), the thermal management of electronic equipment, electric heating systems (e.g. floor heating) and human body comfort (e.g. pocket heater, clothes). Another area of commercial products is the space cooling of buildings. In particular in lightweight buildings with a low thermal mass, the PCM can reduce temperature fluctuation and cut peak temperatures. There are different ways to insert the PCM in the building. They include the additional use of boards and panels, such as gypsum plasterboard with microencapsulated paraffin and aluminium bags filled with salt hydrates. Another option is the integration of the PCM into the building material, such as plaster and concrete containing microencapsulated PCM.

Perhaps the best known example of industrial use of PCM is in mobile pocket heaters used for warming your hands etc. under cold conditions. The principle behind such devices is based on phase change materials and the release of heat is controlled by induced solidification of a super-cooled liquid.

In a first approximation the technology readiness levels of the three types of TES mentioned above is shown below:

Sensible heat storage in water:

Pilot level			Demonstration level			Market mature		
							X	

Sensible heat storage in other materials:

Pilot level			Demonstration level			Market mature		
			X	X				

Phase Change Materials:

Pilot level			Demonstration level			Market mature		
		X	X					

⁷² Joint EASE/EERA recommendations for a European Energy Storage Technology Development Roadmap towards 2030. European Association for Storage of Energy, Brussels March 2013.

Thermochemical energy storage:

Pilot level		Demonstration level			Market mature		
	X						

A.8.3 Technology status in Danish industry and research community

As mentioned above TES in water tanks is widely used in Denmark and Danish industry manufactures a variety of products used in such systems. Also companies producing equipment for control and management of hot water tanks are well-established in Denmark. Due to the long tradition for utilization of district heating technology Denmark has a strong industrial market position in this topic.

In other materials classes sensible heat storage is utilized in masonry stoves (in Danish: masseovn or sometimes finsk masseovn) where heat is stored in ceramic materials to provide a smooth supply of heat based on burning biomass. Danish craftsmen possess considerable knowledge within materials and construction principles for this kind of heat storage and this knowledge can be activated and utilized also for storing heat supplied in the form of electricity from renewable energy sources.

Both PCM and TCS are still to be considered as immature technologies and to the authors' knowledge those technologies are not utilized commercially in Denmark.

However, many new applications of TES can be foreseen in Denmark as the penetration of renewable energy sources accelerates. The most soon to come are likely to be found within the following areas:

- B. Solar heating and cooling of single buildings and private homes
- C. Heating of residential buildings
- D. Heat management in industry to improve energy efficiency and decrease overall processing energy demand and cost
- E. Conventional thermal power generation to improve flexibility of plants and allow better average fuel utilization in combined heat and power plants
- F. Improved utilization of solar heating plants by allowing seasonal storage of heat. Also storage for shorter time periods will become attractive.
- G. Utilization of cheap and fast electricity demand transformed to heat as a balancing service in the electricity grid (alternative to down-regulation of generation)

A.1.1 Status in other European countries

Similarly to the state in Denmark sensible heat storage is also widely used in other countries and has been commercially available for many years in the form of domestic and industrial hot water and ice storage systems.

In several countries outside Denmark the concept of Concentrated Solar Power (CSP) is being developed and this technology relies on sensible heat storage for intermediate storage of solar energy based on a two-tank storage molten salt system. Strong expectations are associated with CSP e.g. in southern Europe, but the technology does not appear to be of interest for Danish weather conditions within a near future.

A somewhat more recent development is seen in electrical storage heaters, which are in particular produced by the Ireland based company Glen Dimplex. The technology is based on electrical heating elements (1-4 kW) which heat ceramic material and thereby stores heat for later use. Internal temperatures may reach 600 C and with a surfaces temperature of 60C.

A.1.2 Development needs for the technology to become market mature

In general cost is a main issue which needs to be addressed for new thermal storage materials and systems to become significant players on the energy market. System investment costs are still somewhat too high.

New cheaper and more effective materials should be developed for use as PCM are still too expensive

If compact long term PCM heat storages using metastable supercooling are developed, such heat storages can be a part of solar heating systems which completely can cover the yearly heat demand of buildings.

Energy density of complete thermal energy storage systems should be increased by use of more compact system designs and better storage materials

Improving heat conductivity of storage materials is important because the conductivity sets a limit for the rate at which heat can be charged and discharged (Power in and out) for a storage facility/system.

For many TES systems (sensible heats storage and phase change systems) thermal insulation is paramount for the storage properties. Thermal losses are too large over time and better insulation and system design is required.

Experiments are required for generation of a data basis to allow optimal integration of TES systems in the electricity grid.

A.1.3 SET Plan targets for the technology

SET Plan targets have not been established for thermal energy storage technologies. However in a recent document⁷³ prepared jointly by the European Association for Storage of Energy and the EERA Joint Programme on Energy Storage a number of mainly economic targets are described as follows:

- to reduce, in the short to medium term (till 2015), the specific investment cost of latent heat storage and sorption storage for industrial waste heat storage and improved thermal management below 100 €/kWh and to identify niche applications for thermo-chemical storage;
- to have, in the medium to long term (2020), a specific investment cost for compact latent heat and thermo-chemical storage below 50 €/kWh;
- to have a long term vision thermo-chemical storage tanks for solar thermal power plants and industrial process heat applications with operating temperatures over 400 °C to take advantage of a high energy storage density. On a medium term, the goal is to provide efficient energy storage tanks with specific investment costs of about 30 to 40 € / kWh.

⁷³ Joint European Roadmap Energy Storage

A.1.4 Stakeholders in Denmark within the topics of the technology

Vølund Varmeteknik, www.volundvt.dk/ - Hot water storage tanks, heat pumps, heat handling and control, solar energy

Metro Therm, www.metrotherm.dk – Hot water storage tanks, heat pumps, heat handling and control, solar energy, district heating

Danfoss - Thermo-control equipment

Grundfos – Pumps

Løgstør Rør – District heating and cooling, pipes for hot and cold fluids

A.1.5 Specific recommendations for the technology in a Danish context

- Perform basic research to identify and develop new thermal energy storage materials in all storage classes: Sensible Heat Storage materials, Phase Change Materials and Thermo-Chemical Storage materials
- Perform basic research to identify and develop new advanced heat transfer fluids for thermal energy storage systems optimally combining heat conduction and heat storage properties in same material.
- Develop complete, compact heat storage systems by use of PCM materials and thermo-chemical reactions utilizing the higher energy density
- Perform studies on utilizing existing building thermal mass for energy storage
- Improve integration of heat storage properties in building elements and construction materials e.g. by including phase change materials in wall constructions.
- Perform R&D of multi-functional thermal management materials like encapsulated PCM for use in slurries and filler materials to improve liquids in sensible heat storage
- Perform research to improve thermodynamic properties of PCM and thermo-chemical storage materials e.g. by use of dedicated additives or by use of composites.
- Develop new effective heat transfer mechanisms for charging and discharging heat stores
- Develop methods to reduce thermal energy losses and exergy losses from heat storage systems. Special focus is recommended on vacuum insulation.
- Develop modelling tools to simulate TES applications (SHS, PCM and TCS) to predict performance under various working conditions (e.g. heat transfer, fluid dynamics).
- Develop modelling tools for TES in combination with use of heat in buildings and industrial processes.
- Develop smart heat stores and recommendations and control strategies for integrating heat storage into the Smart Grid.

A.2 Energy Membrane - Underground Pumped Hydroelectric Storage (EM-UPHS) Energy Storage

A.2.1 Short Technology Description

A typical requirement for a PHS system is the availability of relatively large height differences between the two hydro reservoirs. The pressure delivered for power generation is provided directly by the hydrostatic pressure obtained from this height difference. In situations where such a height difference is not topologically available, concepts of the underground pumped hydroelectric storage (UPHS) type have been proposed. The conventional concept here is to facilitate the height difference by placing the lower reservoir in an underground cavity. The underground cavity is typically a leftover from large scale underground mining.

Countries like Denmark have only a few hilly areas suitable or available for PHS systems. The energy membrane – underground pumped hydroelectric storage (EM-UPHS) system is a novel idea for a PHS system which is based on a storage reservoir, where water is enclosed in a membrane placed underground with soil on top as shown schematically in figure 1. The overlaying soil gives the necessary pressure to run a pump/turbine and store large amount of electrical energy.

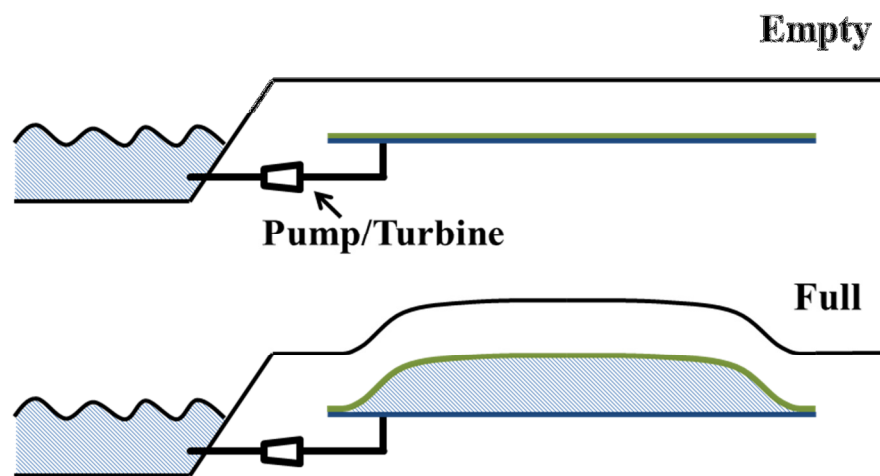

Fig. 1. Sketch of the EM-UPHS concept. Water is pumped into a cavity bonded by two impermeable membranes (blue and green for top and bottom membrane respectively) and soil on top is lifted.

This PHS system is independent of the local topology and can be placed close to a water reservoir – sea, lake, or river – with little or no height difference. The pump/turbine machinery is based on the well-known technology of conventional PHS systems which typically gives a system efficiency of 75% - 85%. The EM-UPHS concept seeks to facilitate a PHS system in a geographical / geological setting where the topology does not allow for a conventional PHS system.

A.2.2 Short technical and economic status

Present experimental results show that the system efficiency of the EM – UPHS technology will be very close to that of the traditional and existing PHS technology. The experiment shows that the energy lost by deformation of the soil is less than 2%. By scaling to a 10 times larger plant (10.000 times the stored energy), the loss is expected to be less 0.5 % of the stored energy.

The next step in the development of the EM – UPHS technology would be to design and build a pilot plant with the installed power of 1 MW and installed storage capacity of approx. 8.9 MWhr. An EM –UPHS plant of this size would still not be economically viable. For the operation in the Danish power grid, it is at this moment estimated, a full scale EM-UPHS plant has to have least of the size 30 MW/200 MWhr, to be economically viable. Table 1 shows the design parameters for the 50x50 m test plant, the proposed pilot plant and a full scale plant.

To calculate the cost to store 1 kWhr of electricity in a full scale EM-UPHS plant, it is necessary to specify some operating condition for the plant. With the operating condition shown I table 2. the cost to store will be approx. 0.40 kr/kWhr.

	Test plant 2011-2013	Pilot Plant 2014-2019	Full Scale plant 2020 ->
Pump / Turbine power	11 kW/5,5 kW	1 MW/700 kW	30 MW/24 MW
Underground storage size	50 m x 50 m	200 m x200 m	500 m x 500 m
Lifting height of soil layer	1 m	4 m	10 m
Soil layer thickness	3 m	10 m	25 m
Soil layer density	2000 kg/m ³	2000 kg/m ³	2000 kg/m ³
Soil layer weight	12.000 tons	800.000 tons	10.000.000 tons
Storage volume	2.500 m ³	160.000 m ³	1.500.000 m ³
Storage pressure	0,6 bar	2 bar	5 bar
Stored energy	34 kWh	8,7 MWh	200 MWh
Tube diameter	0,3 m	1,5 m	4 m
Tube length	50 m	100 m	300 m
Volume flow through turbine	320 m ³ /hr	5,5 m ³ /s	65 m ³ /s
Expected system efficiency	>50%	>75%	>80%

Table 1. Design parameters for the Nybøl Nor EM -UPHS plant, pilot plant and full scale plant

Full scale EM – UPHS plant operating cost			
Total plant construction cost		kr 250,000,000	€ 33,333,333
Annual return	7%	kr 17,500,000	€ 2,333,333
Purchase price for 1 kWhr	€ 0.04	kr 0.30	
Expected efficiency	80%		
Expected operating days per year [days]	280		
Expected pump / turbine operating hours per day [hr]	8		
Pump/turbine size [MW]	30		
Storage size [MWhr]	200		
Annual purchases of electricity [kWhr]	67,200,000		
Annual costs of electricity		kr 20,160,000	€ 2,688,000
Annual sales of electricity [kWhr]	53,760,000		
Sales Price for 1 kWhr		kr 0.70	€ 0.09
Total annual costs		kr 37,660,000	€ 5,021,333
Price per. installed power [price per. kW]		kr 8,333	€ 1,111
Price per. installed storage capacity [price per. kWhr]		kr 1,563	€ 208

Table 2. Full scale EM – UPHS plant operating cost

A full scale EM-UPHS plant connected to the Danish power grid would get its main revenue by delivering two kind of ancillary services:

- Primary reserves
- Secondary reserves, LFC (Load Frequency Control)

The price for the two ancillary services varies, but in the period from January 2011 to July 2013, has the price been on average 100.000 kr/MW pr. month for primary reserves and 75.000 kr/MW pr. month for secondary reserves. This would correspond to an annual revenue of 63.000.000 kr for at 30 MW/200 MWhr full scale plant. It should be noted that the calculations are based on historical prices (without taxes) and thus do not account for future changes of markets.

A.2.3 Technology status in Danish industry and research community

Recently a 50x50 m EM-UPHS test facility was built and tested at Nybøl Nor, a location 12 km outside the Danish city Sønderborg.

The 50x50 m EM-UPHS project was financed through the ForskEL research programme. Following companies and universities participated in the project: GODEvelopmet ApS, Risø DTU, DTU Byg, GEO, Syd Energi, Danfoss A/S, Arkil A/S, Lean Energy Cluster and Sloth-Møller A/S. The total project budget was 7.5 million dkr.

The project's main objectives were:

- To design and build the 50x50 m EM – UPHS test facility.
- Execute a test program with a high number of load cycles.
- Establishment of the theoretical basis for the scaling of the EM – UPHS concept.
- To establish the basis for the estimation of, cost to build and cost to operate, for large scale EM – UPHS systems.

Figure 3. shows the main steps in the building of the 50x50 m UPHS test facility at Nybøl Nor. (top left) Two layers of 1 mm LDPE membrane are rolled out on an area where the soil is profiled. The two membrane layers are welded together at their outer periphery to form a watertight envelope. The 3D shape of the soil profile determines how the cavity shape evolves when water is pumped into the cavity.

The stain of the top membrane is expected to be highest in the area of the outer profiled periphery, (top right) a high strength reinforcement geotextile is placed here on top of the membrane. 17.000 tons of soil is moved onto the membrane (bottom left) in a layer of 3m. When cavity is filled with 1500 m³ water, approx. 12.000 tons of soil will be lifted on average 0.6 meter (bottom right).



Fig. 3. EM – UPHS test plant at Nybøl Nor, Denmark 2012. Top left: Laying and welding of two layers of 1 mm LDPE membrane. Top right: Laying of geotextile reinforcement. Bottom left: Placing of 3 m soil load (17.000 tons) on the two membranes. Bottom right: Summer 2013, test plant after approx. 100 storage cycles.

A.2.4 Status in other European countries

The Danish installation is the only one worldwide

A.2.5 Development needs for the technology to become mature for markets

The next step in the development of the EM – UPHS technology would be to design and build a pilot plant with the installed power of 1 MW and installed storage capacity of approx. 8.9 MWhr.

A.1 High Temperature Latent Heat Storage

A.1.1 High temperature latent heat storage using metals as the phase changing material

High temperature latent heat storage is a relatively unexploited technology due to a number of fundamental technological challenges. Previous studies reveal severe problems related to the poor thermal properties of the traditionally applied PCM (often an inorganic salt) which are difficult to solve. Among other things the low thermal conductivity and capacity, impose a complicated storage design (especially the heat exchanger) and the requirement of geometrically very large storage volumes, due to the low energy density of these materials.

Utilizing instead a metal (for instance aluminium) or alloy as metal based phase changing material (M-PCM) the above-mentioned issues can be circumvented. In particular the high thermal conductivity characteristic of a metal, allows for a much less complicated heat exchanger design, improving the performance of the storage enormously. Furthermore, the high latent heat capacity, giving rise to a high energy density, makes it possible for a confined size of the storage compared to the vast bulk dimensions of for instance long term storage technologies like compressed air energy storage (CAES) or a pumped hydro storage (PHS).

The basic working principles of this technology are depicted in Figure 1, depicting also the simplicity of the system. The storage is charged with cheap power from e.g. a wind turbine. The energy is stored as latent heat in aluminium based PCM. The latent heat is then, when needed, discharged and used to produce steam for a steam turbine. Due to the very favourable thermal properties of a metal based PCM, a high surface area for the heat exchange is not essential. This simplifies the design of the heat exchanger considerable. Nearly no limitations regarding output power are expected in contrast to most salt-based PCMs, where it has to be decided on either high capacity or high output power. Because of the high thermal conductivity it is expected that the positioning of the charging (e.g. electrical heaters) and discharging (e.g. steam pipes) is not critical for the performance. However, the mechanical stresses due to thermal contraction during solidification will be a greater challenge.

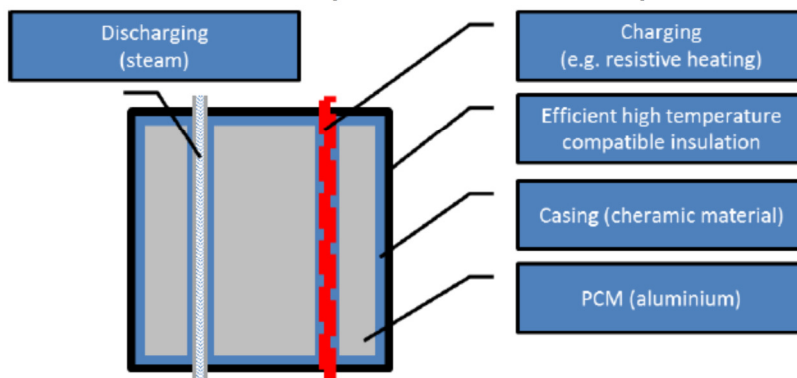

1. Figure 1

A.1.2 Technology status in industry and research

No studies are available, describing how to store electricity as high temperature heat, by applying a phase changing material based on a metal or alloy. Additionally, and even more remarkable, only a very few studies are available regarding the utilization of aluminium as a M-

PCM. The vast majority of the existing studies on latent heat storage systems are based on inorganic salts as the PCM, and mainly concentrate on the development of very complicated heat exchanger systems, which are needed due to the poor thermal properties of the applied PCM (often an inorganic salt). Consequently, this technology is classified as being at the research stage, and is very far from the market.

Only very few studies deal with this technology. To our knowledge the only study that exists, concerning this technology is an ongoing feasibility project carried out by the Danish Technological Institute. The technology shows promise and a small scale experimental project has recently been granted the Danish Technological Institute planning to start February 2014.

Since this concerned technology is novel, and at a very early stage, there are no applications, demonstration activities or even research activities going on. As previously mentioned, there are several studies regarding latent heat storage utilizing salts as PCM, however these systems have too many disadvantages compared to the technology described here.

This technology is at an early research stage, and experimental studies have yet to be carried out. Consequently, the market potential is difficult to estimate, and the time period to market maturation is somewhat long compared to other technologies.

A.1.3 Actors

DTI manages the ongoing project regarding this technology, and has been granted additional resources to perform experimental studies in the near future. The project partners are all private companies and academic institutions which have interest in this development:

- Danish Technological Institute
- Aalborg CSP A/S
- Verdo Produktion A/S
- Støtek Denmark APS
- Jarðfeingi, the Faroese Earth and Energy Directorate
- DTU Department of Mechanical Engineering, Section of Thermal Energy

A.2 Low temperature heat storage using cooling and freezing products as heat storage

A.2.1 Description of the technology

Cooling and freezing products can often be used as heat storage by lowering the temperature of the goods during night time or periods with low electricity prices. Energy savings can be up to 50% due to the lower ambient temperature and higher efficiency of the refrigeration plant. The storing of “cold” makes flexible operation of the refrigeration compressors possible and this flexibility can be capitalized on the Smart Grid flexibility market.. These energy storage technologies are typically used in super market refrigeration systems and cold stores.

Cold storage is in principle equivalent to heat storage: two systems are brought out of thermal equilibrium. Thus – where low temperatures are desired, for instance in food industry - cold storage can be used the same way as heat storage and provide the same kind of services to the overall energy system.

Two families of low temperature heat storage exist:

1. Lowering the temperature in the stored products in a cold store by running the refrigeration system for prolonged period
2. Dedicated production of ice or cold water stored in a vessel

The lowering of the temperature of stored products will require the cooling system to operate at lower temperatures than absolutely required for the quality storage of the products. Operation at a lower temperature will typically be at lower efficiency. On the other hand the operation of the cooling system can be intermittent and potentially inefficient part load operation can be avoided. A lower temperature of the cold store will also give increased thermal losses to the ambient.

However, the amount of heat that can be removed from products in a cold store is very large compared to the heat loss to ambient. The fact that the products need to be stored anyhow makes it interesting to use them for energy storage as a kind of bonus-function. The cold storage primary function and economical interest is to store and preserve products and the storage of energy can be an additional function which requires limited extra investments.

The benefit of lowering the product temperature is only utilized if the product is kept in the cold store for heating up again. Some products are affected by the fluctuation of the temperature. The technology is well established and tested. Frozen or cooled products may be more or less sensitive for variation in temperatures, even at temperature levels below the minimum required temperature for storage. More study would be needed to document this sensitivity and the potential for this storage technology without compromising the quality of different product.

The dedicated production of ice or cold water, including a storage tank requires investment in a system which only purpose is the cold storage of energy and thus the pay back will somehow relate primarily to variation in electricity prices in time.

Historically the efficiency of charging an ice storage has been challenged by the fact that ice is forming on the surface of the refrigeration heat exchangers (evaporators). The ice formation

works as an insulating layer and this will require the operation temperature of the refrigeration system to drop, in order to form thicker ice layers. New development of refrigeration systems operating on water vapour makes it possible to produce the ice without this drop in efficiency. Systems based on water vapour compression and direct contact heat exchangers can produce ice directly with very low temperature difference. These systems are not yet common technology and more research and demonstration must be done to develop economically competitive technologies.

The use of ice storage (ice banks) in the Danish industry has been reduced dramatically during the last years as it often is more efficient to produce cooling water on demand (often 24/7) at temperatures above 0°C. Many systems have been designed with variable load control thus avoiding the need of storage. But the new efficient production using water based compressor systems and direct contact heat exchangers and the rolling out of district cooling have revitalized the technology.

Incorporating ice banks into supermarkets refrigeration systems is expected to show a positive impact on both energy consumption and flexibility of the operation of the refrigeration system.

Heat recovery from refrigeration plants is getting more and more common and may even become a requirement. Where the installations operation traditionally is controlled by the demand for cooling, it may now also be controlled by demand for heating, thus requiring a cold source, which can be in the form of cold store products, cold water tanks or ice banks.

A.2.2 Status in Danish industry

Danish industrial companies and research institutions leading in the world in development of water vapour based chilling technology. The technology is very close to marked introduction. Ice production is included in this work.

B. ANNEX B – SET Plan targets

B.1 Chemical Storage

Table 1: SET Plan targets Alkaline Technology

Property	State-of-the-art	Target 2020-2030	Ultimate goal
Operating current density (A/cm ²)	0.2–0.5	0.1–1	0–2
Operating temperature (°C)	ambient – 120	ambient - 150	ambient - >150
Operating pressure (bars)	1-200	1-350	1-700
Durability (h)	10 ⁵	> 10 ⁵	> 10 ⁵
Cyclability	Poor	improved	high
Production capacity of electrolysis	Up to 50 kg/hour	> 100 kg/hour	> 1000 kg/hour
Non-energy cost (€/kg H ₂)	5	2	1

» PEM Technology

Table 2: SET Plan targets PEM Technology

Property	State-of-the-art	Target 2020-2030	Ultimate goal
Operating current density (A/cm ²)	0 – 1	0 – 2	0 – 5
Operating temperature (°C)	50-80	80-120	100-150
Operating pressure (bar)	1-50	1-350	1-700
Enthalpic efficiency with PGM catalysts	80% at 1 A/cm ²	80% at 2 A/cm ²	80% at 4 A/cm ²
Enthalpic efficiency with non-PGM catal.	30-40% at 1 A/cm ²	60% at 1 A/cm ²	60% at 1 A/cm ²
SPE Voltage drop (mV at 1 A/cm ²)	150	100	67
SPE ionic conductivity (S/cm at 80 °C)	0.17	0.20	0.30
SPE gas permeability to H ₂ (cm ² /s.Pa) (80 °C, full humidity)	10 ⁻¹¹	10 ⁻⁹	10 ⁻⁹
Cathodic PGM (Pt) content (mg/cm ²)	1.0-0.5	0.5-0.05	< 0.05
Anodic PGM (Ir, Ru) contents (mg/cm ²)	1.0-2.0	0.5-0.1	< 0.1
Durability (h)	10 ⁴	10 ⁴ – 5·10 ⁴	> 10 ⁵
Production capacity of electrolysis units	1 kg/hour (≈ 10 Nm ³ /hour)	> 10 kg/hour (≈ 100 Nm ³ /hour)	> 100 kg/hour (≈ 1000 Nm ³ /hour)
Energy (kWh/kg H ₂ at 80 °C, 1 A.cm-2)	56	< 50	48
Non-energy cost (€/kg H ₂)	5	2	1

» Solid Oxide Technology

Table 3: SET Plan targets Solid Oxide Technology

Property	State-of-the-art	Target 2020-2030	Ultimate goal
Operating temperature (°C)	800-950	700-800	600-700
Operating pressure (bars)	1-5	1-30	1-100
Operating current density (A/cm ²)	0–0.5	0–1	0–2
Area Specific Resistance (Ω.cm ²)	0.3-0.6	0.2–0.3	
Enthalpic efficiency	100% at 0.5 A/cm ²	100% at 1 A/cm ²	100% at 2 A/cm ²
Cell voltage degradation (at 1 A/cm ²)	> 10 %/1000hrs	< 1 %/1000hrs	< 0.1 %/1000hrs
Durability (h)	10 ³	10 ⁴	10 ⁵
Electrical modulation	Unknown	0-100	0-100
Load cycles	Unknown	10,000	> 10,000
Start-up time (hours)	12	1-6	< 1-6
Shut down time	Few hours	Few minutes	Few minutes
Start-up /Shut down cycles	< 10	100	1000
Production capacity	<1 kg/hour	10 kg/hour	100 kg/hour
Non-energy cost (€/kg H ₂)	5	2	1

» Hydrogen Storage Technologies

Table 4: SET Plan targets Hydrogen Storage Technologies

Storage Technology	Volumetric density (kg H ₂ /m ³)	Gravimetric density (reversible) (wt %)	Operating pressure (bar)	Operating temperature (K)	Cost* (\$ / kg H ₂)
Compressed gas (H ₂) ⁷⁰	17 - 33	3 - 4.8 (system)	350 & 700	Ambient	400-700*
Cryogenic (H ₂) ⁷¹	35 - 40	6.5 – 14 (system)	1	20	200-270*
Cryo-compressed (H ₂)	30 - 42	4.7 – 5.5 (system)	350	20	400
High pressure - solid	40	2 (system)	350	243 – 298	
Sorbents (H ₂) ⁷²	20 - 30	5 – 7 (material)	80	77	
Metal hydrides (H) ⁷³	< 150	2 – 6.7 (material)	1 – 30	ambient – 553	>500
Complex hydrides (H) ⁷⁴	< 120	4.5 – 6.7 (material)	1 - 50	423 – 573	300-450*
Chemical hydrides (H) ⁷⁵	30	3 – 5 (system)	1	353 – 473	160-270**

* cost estimates based on 500,000 units production; ** regeneration and processing costs not included

B.2 Batteries

SET Plan targets Lithium Ion Technology for e-mobility (EV)

Property	State-of-the-art	Target 2020-2030	Ultimate goal
Operating power density (kW/kg)	0.60	0.80	1.0
Operating energy density (kWh/kg)	0.25	0.75	2.1
Operating energy density (kWh/L)	0,058	0.15	0,8
Peak charge rate (C)	2.5	6	12
Peak discharge rate (C)	10	12	12
Operating charge temperature (°C)	5 to 55	-10 to 85	-30 to 150
Operating discharge temperature (°C)	-20 to 60	-30 to 120	-40 to 150
Cycle life (1000 cycles)	2.5	5	25
Calendar life (years)	8	12	30
Safety	Fair	Good	Excellent
Environmental waste impact	Poor	REACH compliant	REACH compliant
Resource availability	Fair	Good	Excellent
Cost (€/kWh)	300	180	100

SET Plan targets Lithium Ion Technology for Stationary energy storage (ESS)

Property	State-of-the-art	Target 2020-2030	Ultimate goal
Operating power density (kW/kg)	0.60	0.70	1.0
Operating energy density (kWh/kg)	0.25	0.50	2.5
Operating energy density (kWh/L)	0,058	0.08	0.8
Peak charge rate (C)	2.5	3	5
Peak discharge rate (C)	10	10	10
Operating charge temperature (°C)	5 to 55	-10 to 85	-30 to 120
Operating discharge temperature (°C)	-20 to 60	-20 to 85	-30 to 120
Cycle life (1000 cycles)	2.5	8	25
Calendar life (years)	8	15	30
Safety	Fair	Good	Excellent
Environmental waste impact	Poor	REACH compliant	REACH compliant
Resource availability	Fair	Good	Excellent
Cost (€/kWh)	300	150	50

Table 5: SET Plan targets for batteries towards 2030 and beyond

System	Current performance	Target 2020-2030	Target 2050
Li ion/Energy version	Max. 241Wh/kg – 535Wh/L (Co based); ca. 500 cycles Safe : 130Wh/kg – 300Wh/L (LFP based); ca. 2000 cycles -20, +60 °C ca 500-1000€/kWh (or 25c€/kWh/cycle)	ca. 180-350Wh/kg – 350-800Wh/L Safe >. 10000 cycles -20, +70 °C ca 200€/kWh (or 10c€/kWh/cycle) i.e. phosphates <10€/kg or lamellar oxides <20€/kg; separator <1€/m ²	>350Wh/kg -> 800Wh/L Safe >10000 cycles -20, +70 °C < 200€/kWh
Li ion/Power version	50-90Wh/kg-105-190Wh/L ca. 3kW/kg ca 10000 cycles -10, +60 °C > 1000€/kWh	170-220Wh/L >5kW/kg Safe >. 15 years -20, +70 °C ca 20€/kW i.e. LTO <10€/kg	>100Wh/kg –220Wh/L ca. 10kW/kg Safe >. 15 years -20, +70 °C ca 20€/kW or <
Redox Flow Batteries (Vanadium, ZnBr ₂) 10-20Wh/kg – 15-25Wh/L (Vanadium);	10-20Wh/kg – 15-25Wh/L (Vanadium); 10-20 years (>10000 cycles) 10, +40 °C 50-60Wh/kg (ZnBr ₂ based); >2000 cycles Projected service cost (Capex and Opex) 10c€/kWh Energy cost 400€/kWh Power cost 600€/kW	Gen2 Vanadium Bromide 20-40Wh/kg Wider operating T° range (>100 °C) Projected service cost (Capex and Opex) 7c€/kWh Energy cost 120€/kWh Power cost 300€/kW	Reduction of total system cost (Capex & Opex) Projected service cost (Capex and Opex) 3c€/kWh Energy cost 70€/kWh Power cost 200€/kW
Metal air systems	700Wh/kg (Li air Polyplus) Poor Cycles	>500Wh/kg 300-500€/kWh 3000 cycles	500-1000Wh/kg 10000 cycles ca. 100€/kWh
Na-Ion		Expected decrease in battery cost ~40%	
Li-S	350Wh/kg – 350Wh/L (Sion Power) High self-discharge 4-6%/month (sulphur migration), poor life cycle (60-100 cycles) and safety issue -40°C-25 °C	500Wh/kg 3000 cycles <350€/kWh	600Wh/kg 10000 cycles ca. 200€/kWh

Additional target information⁷⁴ for Electrochemical Energy Storage technology towards 2030

Targets for Lead technology for the period 2020-2030:

Energy cost < 150-100 €/kWh or << 0.08-0.04 €/kWh/cycle

⁷⁴ Joint EASE/EERA recommendations for a European Energy Storage Technology Development Roadmap towards 2030. European Association for Storage of Energy, Brussels March 2013.

Temperature operating range for stationary applications: -30 to +60°C
Specific performances: 60-100 Wh/kg and 140-250 Wh/L
Cycle life: > 3,000 (80% DoD) -10,000 cycles (60% or 80% DoD)

Targets for Nickel technology for the period 2020-2030:

Energy cost < 250-1,000 €/kWh
Temperature operating range for stationary applications: -40 to +70°C
Specific performances: 60-140 Wh/kg up to 80-200 Wh/kg and 80-450Wh/L up to 100-600Wh/L
Cycle life: > 6,000 - 8,000 cycles (80% DoD)

Low cost technology targets for high temperature batteries (sodium-based) with a substantially increased cyclability (in excess of 10,000 complete charge/discharge cycles).

The following installed cost targets (set for everything needed up to direct current output to the converter) reflect the push and pull of the energy storage market:

- Current: \$3,000/kW
- 2020: \$2,000/kW
- 2030: \$1,500/kW

The following range of lifecycle costs could also help achieve system targets:

- Current: \$0.04–\$0.75/kWh/cycle
- 2020: \$0.01–\$0.27/kWh/cycle
- 2030: \$0.01–\$0.08/kWh/cycle

Low cost technology targets for redox flow:

Targets for the period 2020-2030: Energy cost 120€/kWh and Power cost of 250€/kW. Temperature operating range -20 °C to +60°C, while maintaining the rest of the figures in values similar to current Vanadium technology: 15-25 Wh/L, > 10,000 cycles.

Targets for Li ion technology for the period 2020-2030:

Energy cost < 200 €/kWh or << 0.10 €/kWh/cycle and Power cost <20 €/kW.

Temperature operating range for mobile applications: -20 to +60°C

Temperature operating range for stationary applications: 0°C to 40°C

Specific performances: 180-350 Wh/kg and 350-800 Wh/L, > 5,000 cycles (100% DoD).

SET Plan targets Lithium Ion Technology for Stationary energy storage (ESS)

Property	State-of-the-art	Target 2020-2030	Ultimate goal
Operating power density (kW/kg)	0.60	0.70	1.0
Operating energy density (kWh/kg)	0.25	0.50	2.5
Operating energy density (kWh/L)	0,058	0.08	0.8
Peak charge rate (C)	2.5	3	5
Peak discharge rate (C)	10	10	10
Operating charge temperature (°C)	5 to 55	-10 to 85	-30 to 120
Operating discharge temperature (°C)	-20 to 60	-20 to 85	-30 to 120
Cycle life (1000 cycles)	2.5	8	25
Calendar life (years)	8	15	30
Safety	Fair	Good	Excellent
Environmental waste impact	Poor	REACH compliant	REACH compliant
Resource availability	Fair	Good	Excellent
Cost (€/kWh)	300	150	50

B.3 Compressed Air Energy Storage

SET Plan targets⁷⁵ for CAES technologies towards 2030 and beyond

Current performance	Target 2020-2030	Target 2050
<p>Adiabatic (with heat storage; 70% efficiency expected)</p> <p>Diabatic (need extra heat during discharge; 55% efficiency expected)</p> <p>Isothermic (Low capacity & power storages; 70-75% efficiency)</p> <p>Liquefied gas (higher cost for similar efficiency but not geographical dependent) CAES</p> <p>\$300-350/kWh (200-250€/kWh) or Capital Cost €470/kW-€2170/kW (depends on CAES type and sizing)</p>	<p>Advanced adiabatic materials for high T° thermal storage: stable, resistant, cheap, high heat capacity, good conductivity & low degradation</p> <p>Demonstration of huge thermal energy storage with new media and container to resist pressure (>200-300 bars) and thermal stresses (gradients >600 °C)</p> <p>Liquefied gas systems capital cost/demonstration of thermal</p> <p>TES unit cost > \$30 to \$40/kWh (20 to 30€/kWh) depending on storage capacity</p>	<p>50% cost to meet longer-term TES cost goals</p> <p>Costs depend on scale and TES</p> <p>Improving efficiency (>70-75%)</p>

⁷⁵ http://setis.ec.europa.eu/activities/materials-roadmap/Materials_Roadmap_EN.pdf/view

C. ANNEX C – data from other sources

Tables from external sources giving performance data and economic data for energy storage technologies

Table 4. Cost and Performance Assumptions

Technology	Power Subsystem Cost \$/kW	Energy Storage Subsystem Cost \$/kWh	Round-trip Efficiency %	Cycles	Source
Advanced Lead-acid Batteries (2000 cycle life)	400	330	80	2000	8
Sodium/sulfur Batteries	350	350	75	3000	8, 9, 10
Lead-acid Batteries with Carbon-enhanced Electrodes	400	330	75	20000	8, 10, 13
Zinc/bromine Batteries	400	400	70	3000	10
Vanadium Redox Batteries	400	600	65	5000	11
Lithium-ion Batteries (large)	400	600	85	4000	8,10
CAES	700	5	N/A (70)	25000	8
Pumped hydro	1200	75	85	25000	10
Flywheels (high speed composite)	600	1600	95	25000	10
Supercapacitors	500	10000	95	25000	12

SANDIA REPORT

SAND2011-2730

Unlimited Release

Printed April 2011

Energy Storage Systems Cost Update

A Study for the DOE Energy Storage Systems Program

Susan Schoenung, Ph.D.

8. Nourai, Ali. *Installation of the First Distributed Energy Storage System (DESS) at American Electric Power (AEP)*. SAND2007-3580. 2007.

9. Energy Insights. Summary of ARRA-funded energy storage projects. March 2010.

10. Electricity Advisory Committee. "Bottling Electricity: Storage as a Strategic Tool for Managing Variability and Capacity Concerns in the Modern Grid." December 2008.

11. Memo from the Harvard University John F. Kennedy School of Government, Belfer Center for Science and International Affairs, March 2010

12. Electricity Storage Association website: www.electricitystorage.org

Annex A
Technical overview of electrical energy storage technologies

Table A-1 – Overview technical data for EES
 (fraunhofer)

Battery Technology	Nominal Voltage [V]	Capacity per cell [Ah]	Response Time	Energy Density [Wh/kg]	Energy Density [Wh/l]	Power Density W/kg	Typical Discharge time	Energy Efficiency η_{Wh} [%]	Lifetime [a]	Typ. Cycle Lifetimes [cycles]	Typical applications
PHS	-	-	min	0.2 – 2	0.2 – 2	0.1 – 0.2	hours	70 – 80	> 50	> 15 000	Time shifting, Power quality, Emergency supply
CAES	-	-	min	-	2 – 6	0.2 – 0.6	hours	41 – 76	> 25	> 10 000	Time shifting
Flywheel	-	0.7 – 1.7 MW	< sec	5 – 30	20 – 60	5 000	seconds	90 – 90	15 – 20	2*10 ⁴ – 10 ⁵	Power quality
Lead acid	2.0	1 – 4 000	< sec	30 – 45	50 – 80	300 – 700	hours	75 – 80	3 – 15	250 – 1 500	Off-Grid, Emergency supply, Time shifting, Power quality
NiCd Vented sealed	1.2	2 – 1 500 0.05 – 25	< sec	15 – 40 30 – 45	15 – 60 80 – 110	75 – 700 (vented)	hours	60 – 80 60 – 70	5 – 20 5 – 10	1 600 – 3 000 500 – 800	Off-Grid, Emergency supply, Time shifting, Power quality
NiMH sealed	1.2	0.05 – 110	< sec	40 – 80	80 – 200	500 – 3 000	hours	65 – 75	5 – 10	600 – 1 200	Electric vehicle
Li-ion	3.7	0.05 – 100	< sec	60 – 200	200 – 400	1 300 – 10 000	hours	85 – 95	5 – 15	500 – 10 ⁴	Power Quality, Network efficiency, Off-Grid, Time shifting, Electric vehicle
Zinc air	1.0	1 – 100	< sec	130 – 200	130 – 200	50 – 100	hours	60 – 70	> 1	> 1 000	Off-Grid, Electric Vehicle
NaS	2.1	4 – 30	< sec	100 – 250	150 – 300	120 – 180	hours	70 – 85	10 – 15	2 500 – 4 500	Time shifting, Network efficiency, Off-Grid
NaNiCl	2.6	38	< sec	100 – 200	150 – 200	250 – 270	hours	80 – 90	10 – 15	~ 1 000	Time shifting, Electric vehicles
VRFB	1.6	-	sec	15 – 50	20 – 70	0.5 – 2	hours	60 – 75	5 – 20	> 10 000	Time shifting, Network efficiency, Off-Grid
HFB	1.8	-	sec	75 – 85	65	1 – 25	hours	65 – 75	5 – 10	1 000 – 3 650	Time shifting, Network efficiency, Off-Grid
Hydrogen central decentral	-	-	sec – min	33 330	600 (200 bar)	0.2 – 2 2.0 – 20	hours – weeks	34 – 44	10 – 30	10 ³ – 10 ⁴	Time Shifting
SHG	-	-	min	10 000	1 600 (200 bar)	0.2 – 2	hours – weeks	30 – 36	10 – 30	10 ³ – 10 ⁴	Time Shifting
DLC	2.5	0.1 – 1 600 F	< sec	1 – 15	10 – 20	40 000 – 120 000	seconds	95 – 95	4 – 12	10 ⁴ – 10 ⁵	Power Quality, Effective Connection
SMEB	-	-	< sec	-	6	2 800	seconds	75 – 80	*)	*)	Time Shifting, Power Quality

*) Insufficient experience in applications

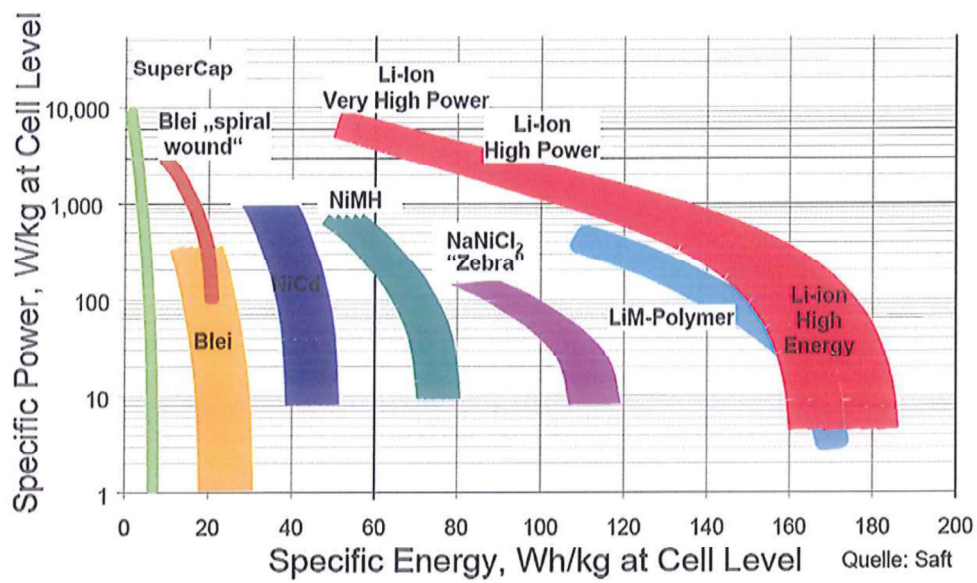

© Fraunhofer ISE



SAFT Batteries

Figure 6

Technology choices in electricity system flexibility [4].

	Application by response timeframe										Discharge time/ duration
	Hours					Minutes			Seconds		
	Energy arbitrage	Generation capacity deferral	(T&D) invest- ment deferral	Congestion management	Voltage support	Black start	Spinning reserve/load following	Renewable ramp recuction	Regulation	Power quality	
Generation											
Conventional generation		M	M		M	M	M	M	M		> Hours
Generation re-dispatch			M	M							> Hours
Hydro generation			M	M	M	M	M	M	M		> Hours
Distributed generation					D	D	D	D	D	D	Minutes/hours
Demand response											
Industrial	M	M		D	D		M				Hours
Commercial/residential				D	D	D	D	D	D	D	Minutes/hours
Network/interconnection											
Interconnection	M	M	M	M		M	M	M			Hours
Transmission	M	M	M	M	M	M			M	M	> Hours
Static compensation devices			M		M						> Hours
Power electronics										M	Seconds
Storage technologies											
Pumped hydro	M	M	M	M	M	M	M	M	M		Hours
CAES	C	C	C	C	C	C	C	C			Hours
Flywheel						D	D	D	D	D	Minutes
Super capacitor										D	Seconds
Battery technology						C/D	C/D	C/D	C/D	C/D	Hours/minutes
Operational measures											
Protection measures			M	M							Seconds
Dynamic line rating			C	C							Hours
Forecasting	M										Hours
Technology maturity key: M Mature C Commercial D Demonstration											

DTU International Energy Report 2013, ENERGY STORAGE OPTIONS FOR FUTURE SUSTAINABLE ENERGY SYSTEMS, Edited by Hans Hvidtfeldt Larsen and Leif Sønderberg Petersen / DTU National Laboratory for Sustainable Energy / November 2013 (Data from: Energy Technology Perspectives 2012, IEA, Paris)

DTU International Energy Report 2013, ENERGY STORAGE OPTIONS FOR FUTURE SUSTAINABLE ENERGY SYSTEMS, Edited by Hans Hvidtfeldt Larsen and Leif Sønderberg Petersen / DTU National Laboratory for Sustainable Energy / November 2013 (Data from: Electric Energy Storage Technology Options: A White Paper Primer on Applications, Costs and Benefits. EPRI, Palo Alto, CA, 2010. 1020676)

Figure 8

Operational benefits monetising the value of energy storage [1].

Figure 8 shows the many ways in which energy storage can supply quantifiable benefits to future smart power grids. These benefits span a wide range of capacities, power outputs and timescales, and cover the spectrum of power users, carriers, generators and regulators. In addition, demand-side management and virtual power plants - two options for mobilising latent flexibility in present and future energy systems - may supplement conventional storage solutions. New solutions may arise through integration of the power, heat, gas and transport sectors.

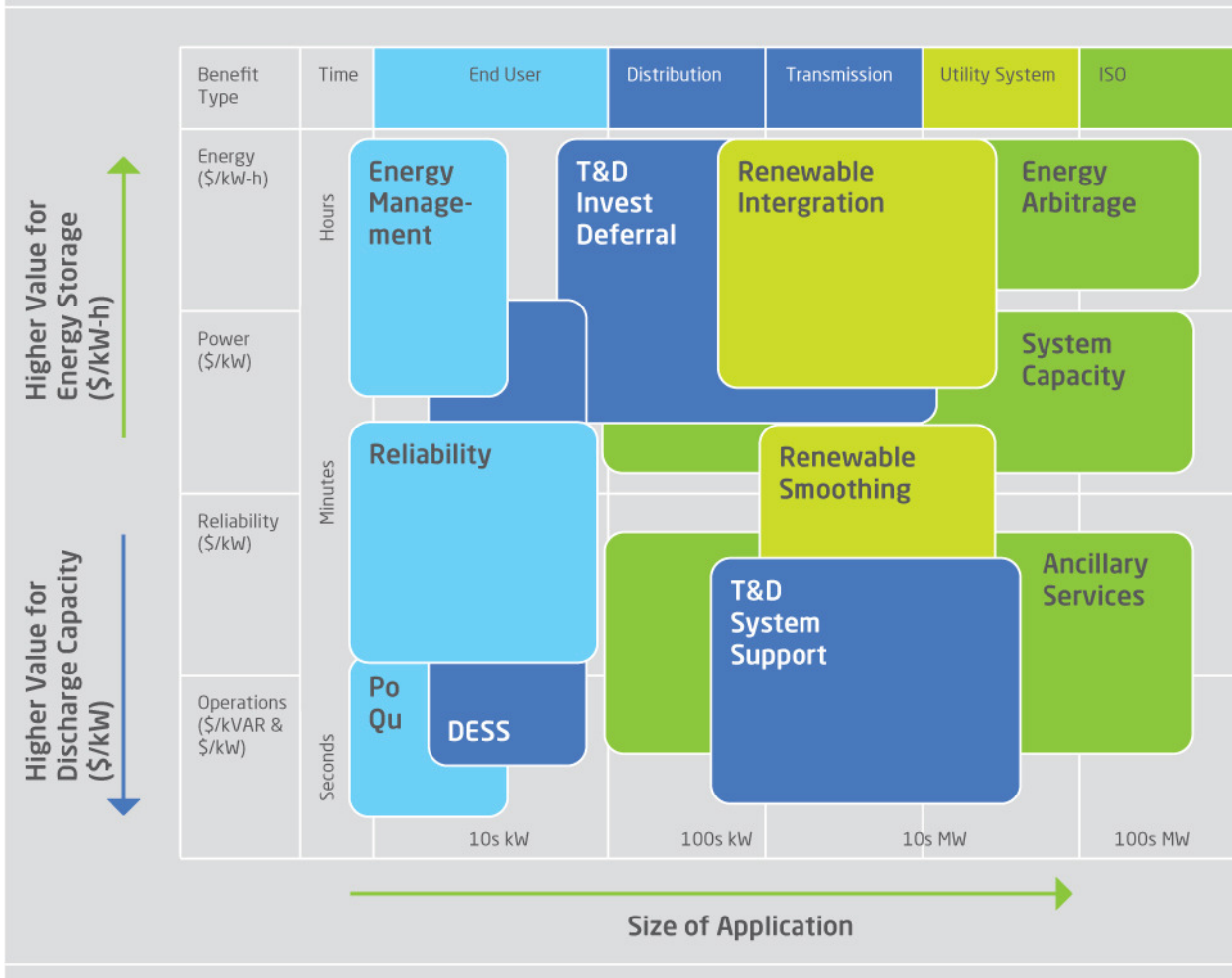
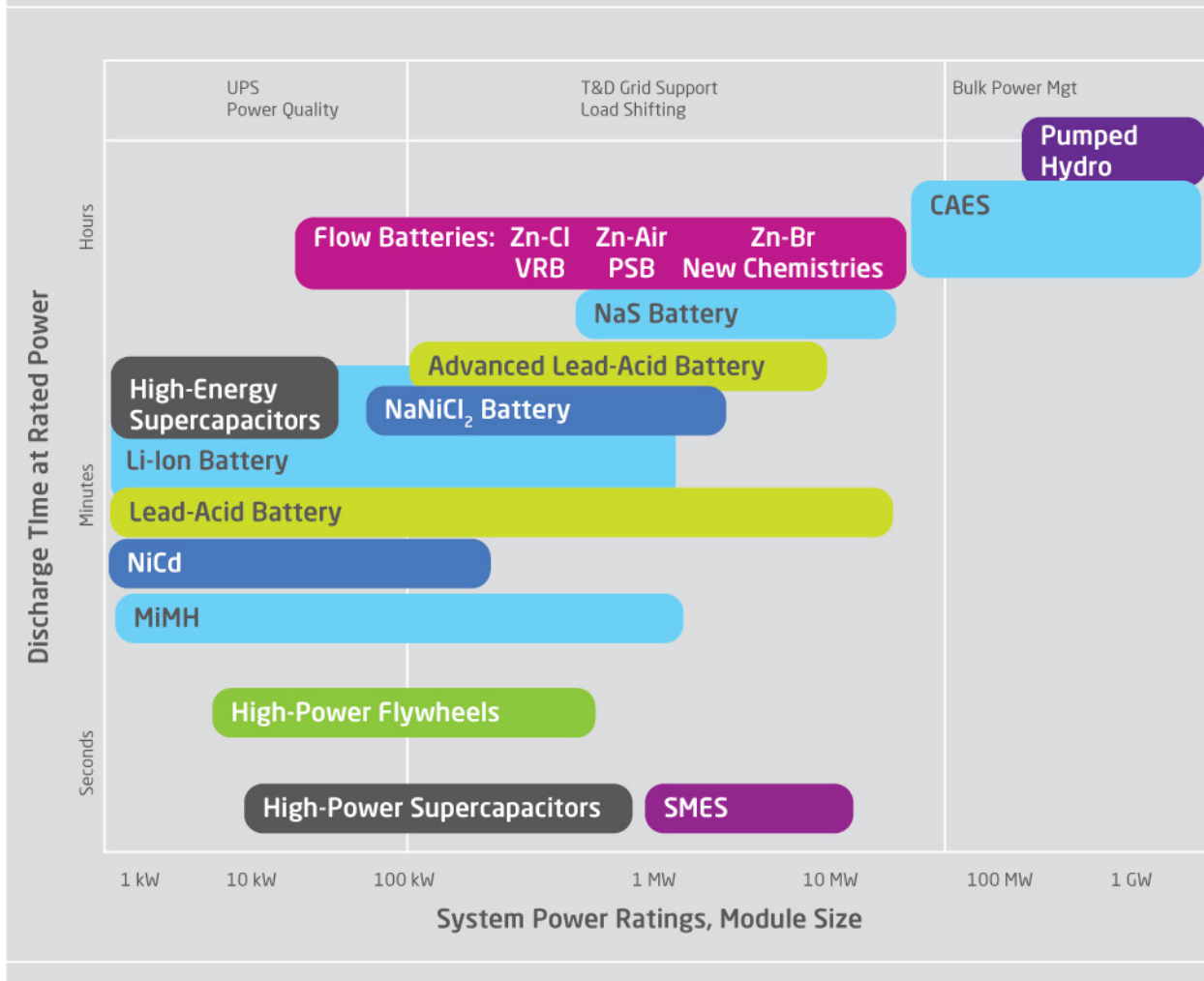

Figure 9

Energy storage technologies classified according to storage capacity and operating timescale [1].



DTU International Energy Report 2013, ENERGY STORAGE OPTIONS FOR FUTURE SUSTAINABLE ENERGY SYSTEMS, Edited by Hans Hvidtfeldt Larsen and Leif Sønderberg Petersen / DTU National Laboratory for Sustainable Energy / November 2013 (Data from: Electric Energy Storage Technology Options: A White Paper Primer on Applications, Costs and Benefits. EPRI, Palo Alto, CA, 2010. 1020676)

Table 1

Energy storage for utility transmission and distribution grid support. The megawatt- and kilowatt-scale energy storage systems listed here have the potential to affect areas including transmission and distribution substation grid support, peak shaving, capital deferral, reliability and frequency regulation [1].

Technology option	Maturity	Capacity (MWh)	Power (MW)	Duration (hours)	% Efficiency (total cycles)	Total cost (\$/kW)	Cost (\$/kWh)
CAES (aboveground)	Demo	250	50	5	(>10,000)	1950-2150	390-430
Advanced Pb-acid	Demo	3.2-48	1-12	3.2-4	75-90 (4500)	2000-4600	625-1150
Na/S	Commercial	7.2	1	7.2	75 (4500)	3200-4000	445-555
Zn/Br flow	Demo	5-50	1-10	5	60-65 (>10,000)	1670-2015	340-1350
V redox	Demo	4-40	1-10	4	65-70 (>10,000)	3000-3310	750-830
Fe/Cr flow	R&D	4	1	4	75 (>10,000)	1200-1600	300-400
Zn/air	R&D	5.4	1	5.4	75 (>4500)	1750-1900	325-350
Li-ion	Demo	4-24	1-10	2-4	90-94 (>4500)	1800-4100	900-1700

DTU International Energy Report 2013, ENERGY STORAGE OPTIONS FOR FUTURE SUSTAINABLE ENERGY SYSTEMS, Edited by Hans Hvidtfeldt Larsen and Leif Sønderberg Petersen / DTU National Laboratory for Sustainable Energy / November 2013 (Data from: Electric Energy Storage Technology Options: A White Paper Primer on Applications, Costs and Benefits. EPRI, Palo Alto, CA, 2010. 1020676)