

Technical University of Denmark



Hospital bed ventilation: impact of operation mode on exposure

Bolashikov, Zhecho Dimitrov; Melikov, Arsen Krikor; Barova, Mariya

Published in:

Proceedings of ROOMVENT 2014, 13th SCANVAC International Conference on Air Distribution in Rooms

Publication date:

2014

[Link back to DTU Orbit](#)

Citation (APA):

Bolashikov, Z. D., Melikov, A. K., & Barova, M. (2014). Hospital bed ventilation: impact of operation mode on exposure. In Proceedings of ROOMVENT 2014, 13th SCANVAC International Conference on Air Distribution in Rooms [Paper ID 108]

DTU Library

Technical Information Center of Denmark

General rights

Copyright and moral rights for the publications made accessible in the public portal are retained by the authors and/or other copyright owners and it is a condition of accessing publications that users recognise and abide by the legal requirements associated with these rights.

- Users may download and print one copy of any publication from the public portal for the purpose of private study or research.
- You may not further distribute the material or use it for any profit-making activity or commercial gain
- You may freely distribute the URL identifying the publication in the public portal

If you believe that this document breaches copyright please contact us providing details, and we will remove access to the work immediately and investigate your claim.

HOSPITAL BED VENTILATION: IMPACT OF OPERATION MODE ON EXPOSURE

Zhecho Dimitrov Bolashikov¹, Arsen Melikov¹ and Mariya Barova¹

¹ Technical University of Denmark, Department of Civil Engineering, Section for Indoor Climate and Building Physics, International Center for Indoor Environment and Energy, Denmark

Abstract

Full-scale measurements were performed in a climate chamber set as a two-bed hospital room with overhead ventilation. Air temperature was kept constant at 22 °C. Two breathing thermal manikins were used to mimic a sick patient lying sideways in one of the beds and a doctor. A thermal dummy mimicked a second patient lying in the other bed. The doctor stood up 0.55 m from the bed facing the sick patient. Two pairs of localized ventilation units were attached near the heads of both patients alongside the beds to capture, clean and release the captured exhaled air from the lying patients. When the bed units were not operated the room was ventilated at 3, 6 or 12 ACH. The background ventilation was kept at 3 ACH when the units were used. The ‘sick patient’ was exhaling through the mouth and inhaling from the nose. Tracer gas (R 134a) was mixed with the exhaled air to mimic airborne droplets and droplet nuclei of less than 3 µm aerodynamic diameter. Two modes of operation of the bed incorporated ventilation unit were tested: releasing the cleaned air upwards (pull mode) or supplying it sideways over the lying patient (“push and pull” mode). The strategy to exhaust pollutants close o release proved to be efficient. The bed incorporated ventilation unit was effective in capturing the air exhaled by the sick lying patient and performed significantly better than the overhead ventilation at 12 ACH. The exposure for the doctor and the second patient was further reduced when the bed incorporated ventilation unit was operated in the “push and pull” mode compared to the pull mode.

Keywords: hospital bed ventilation, source control, push and pull flow control, exposure, plug and operate

1 Introduction

Ventilation supplies clean air indoors to remove the generated indoors contaminants and provide comfortable environment for occupants. Among the contaminants released indoors of greatest concern are those that can cause adverse health effects. These include airborne pathogens (viruses, bacteria and toxins/allergens), which when inhaled or in contact with mucosal tissue (eyes or mouth) can initiate disease in the host. Therefore they are named bio-aerosols. Main sources of airborne pathogens indoors are the occupants themselves. People release bio-aerosols by expelled air when breathing, speaking, coughing, sneezing or singing, (Cole and Cook 1998, Edwards et al. 2004 and Wong et al. 2004). Two ranges of particles were reported by Nicas et al. (2005): large particles with geometric mean and geometric standard deviation of 160 µm and 1.7 µm respectively and small particles with geometric mean and geometric standard deviation of 9.8 µm and 9 µm. Shortly after release the generated particles undergo evaporation and form nuclei with diameters nearly half of initial size, (Nicas et al. 2005). The evaporation of bio-aerosols as well as their spread indoors depends on the initial velocity of the respiratory air jet and the ambient room conditions, i.e. background velocities, air temperature and relative humidity (Xie and Li 2006). Therefore in occupied spaces the use of ventilation affects the spread and deposition of particles. This is especially important in hospital environment where the concentration of sick and infective individuals is high. Therefore good ventilation design plays an important role for controlling the spread of airborne diseases, (Streifel

1999, Kaushal et al. 2004 and Beggs et al. 2008). However, hospital ventilation may fail to successfully and fully remove the pathogens from the air and may result in further spread of airborne disease within the building envelope, (Li et al. 2007). This becomes problematic as the health of medical staff members, hospitalised patients and visitors is at risk. Furthermore the consequence can be uncontrolled spread of the disease that can result in heavy costs for the hospital facility and eventually epidemics.

Existing ventilation strategies and technologies rely on dilution by supplying extra amounts of conditioned clean air. This also makes them energy inefficient and very demanding. In many cases they also create problems connected with elevated velocity in rooms and local thermal discomfort due to draft. Control over the flow interaction at the vicinity of the patients may reduce the exposure to and the migration of pathogen contaminated exhaled/coughed air. These new advanced air distribution techniques should be able to meet the requirements of all occupants for inhaled air quality and thermal comfort. At the same time the new ventilation strategies should be user friendly and energy efficient.

Advanced air distribution method was developed and its efficient performance documented (Melikov et al. 2011). The performance of the method was examined with respect to different modes of operation. The results are presented in this paper.

2 Method

Experiments were designed and performed in a climate chamber with dimensions 4.75 m x 4.65 m x 2.60 m (W x L x H) furnished to simulate a two bed hospital isolation room. The distance between the beds was set to 1.3 m. Five ceiling-mounted light fixtures (6 W each) provided the background lighting. The chamber was located in a larger hall, where the temperature was kept constant and equal to the air temperature in the test room. A thermal manikin consisting of 23 body segments was used to simulate a sick patient lying in the bed next to which the doctor was standing. The manikin was dressed with patient pajamas of 0.38 Clo. The manikin was equipped with an artificial lung, (Melikov and Kaczmarczyk 2007), to simulate a breathing sick patient. One full breathing cycle consisted of three steps and lasted 6 s: inhalation – 2.5 s, exhalation – 2.5 s and break – 1 s. The characteristics of the breathing cycle were: inhalation nose, exhalation mouth at tidal flow rate of 0.24 L/s (6 L/min), (Hyldgaard 1994). A second dressed thermal manikin (1.02 Clo) with realistic body size, shape and surface temperature distribution was used to resemble a “doctor” standing next to the bed of the mimicked sick patient: 0.55 m away. The doctor was facing the sick patient. The manikin consisted of 17 sections. Each manikin released 60 W of sensible heat on average. A heated dummy with simplified body geometry was used to mimic the second patient lying in the other bed. The total generated heat power from the dummy was 60 W. The two beds were placed in parallel. The layout of the set-up is shown in Figure 1.

During all experiments overhead mixing ventilation was used. The supply air was 100% outdoor air with no recirculation. The supply diffuser was a square diffuser with an unperforated face plate and with a 3-way-discharge. Two square ceiling mounted diffusers with perforated face plate were used for exhausting the air from the room. They were located above the heads of the patients. The exhausted air was equally balanced between the two diffusers.

Four devices named Hospital Bed Integrated Ventilation Cleansing Unit (HBIVCU), one at each side of the two beds at patients’ head side, were used in the experiment, Figure 1. The HBIVCU is shaped as a box with dimensions of 0.60 m x 0.145 m x 0.60 m (L x W x D). It exhausts the air from the pulmonary activities of the sick occupant/patient (breathing, coughing, sneezing etc.) when lying in bed and cleans that air from the pathogens via UV C light or other air cleansing techniques incorporated inside the box. The clean air is then discharged through a horizontal slot(s), at a high initial momentum, towards the ceiling where it is exhausted by the total volume ventilation, Figure 2b. The side opening, located on the larger side of the box and facing the patient in the bed, had dimensions 0.50 m x 0.135 m (L x W). The dimensions of the discharge opening (slot) located on the

top of the box were 0.535 m x 0.05 m (L x W). It is important to note that in some applications the suction can be used as a supply and the discharge opening as a suction opening, “push and pull” mode (discussed later in the text). A separate HVAC system was assigned to supply air isothermally to the discharge section of the box and to exhaust the captured coughed air from the suction section of the box at controlled flow rates. The amount of the air supplied and exhausted was always the same and was determined by the discharge velocity from the slot on the top of the box. The experiments were performed with 2 pairs of HBIVCUs installed (one at each side of the two beds) or without any device at all – reference case.

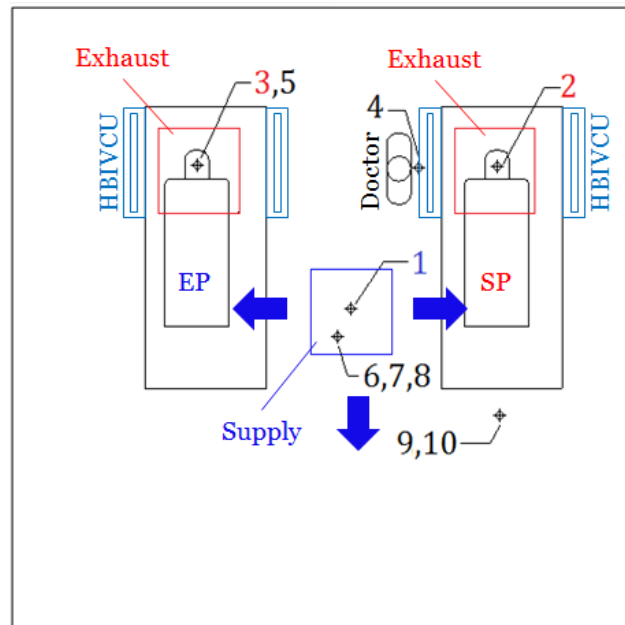

Figure 1. Experimental set-up and locations of the sampling points for the tracer gas concentration measurements; top view: sick patient (SP), exposed patient (EP), 1 – supply, 2 – exhaust over SP, 3 – exhaust over EP, 4 – mouth of SP, 5 – mouth of EP, 6 – centre of the room 1.7 m above the floor, 7 – centre of the room 1.1 m above the floor, 8 – centre of the room 0.1 m above the room, 9 – at feet of SP 1.7 m above the floor, 10 – at feet of SP 1.1 m above the floor.

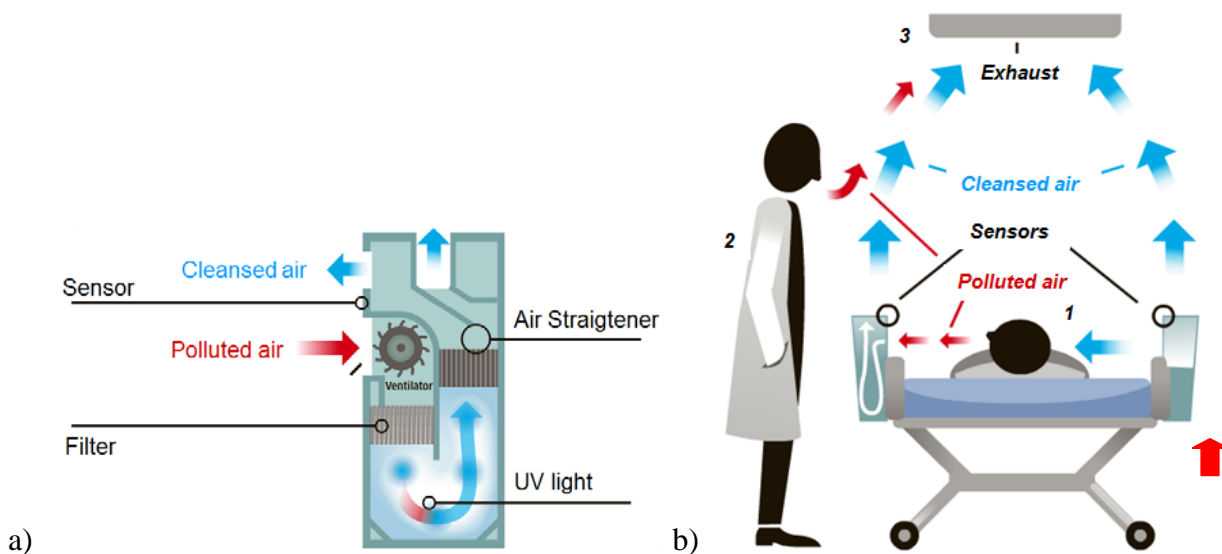

Figure 2. Hospital Bed Integrated Ventilation Cleansing Unit: a) conceptual set-up, b) application of unit in hospital environment: 1) patient, 2) doctor and 3) total volume ventilation exhaust.

The experiments were performed at 3, 6 and 12 ACH. When the HBIVCUs were operated the total volume ventilation was set at 3 ACH. The flow rate of each HBIVCU was set to 18.55 L/s or 0.7

m/s exit velocity from the vertical air jet from the top slot. Room temperature was kept at 22°C, while the relative humidity was not controlled but was measured to be between 30% and 40% during all experiments. Temperature and flow rate of supply and exhaust air, temperature inside the test room as well as the amount of air exhausted were recorded and controlled constantly to keep the set values.

Several modes of operating the HBIVCUs were tested, Figure 3. Pull mode: the side slots of both units positioned at the patients' beds exhausted the exhaled air, while the top slots were discharging vertically clean air, Figure 3a. Assisting "push and pull" mode: one of the side slots was gently supplying clean air, "assisting" and guiding the exhaled air from the lying on one side patient towards the side opening of the unit across the bed which served as an exhaust, Figure 3b. Counter "push and pull" mode: similar to the assisting "push and pull" mode but here the unit's side opening facing the patient was supplying the clean air against the exhalation flow, while the second unit was exhausting, Figure 3c. In the last mode tested, namely "the "push and pull" mode with patient exhaling upwards", the patient was lying on back and was breathing upwards, Figure 3d.

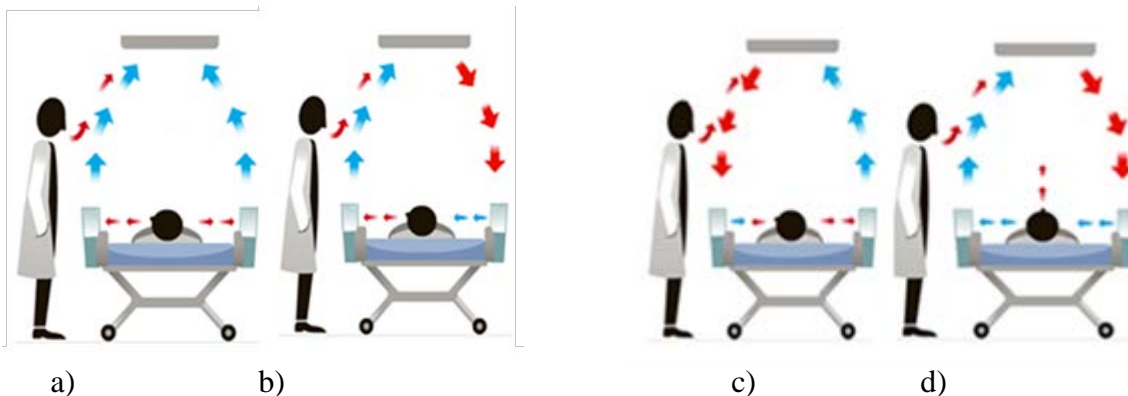

Figure 3. Modes of operation of the HBIVCU: a) pull mode, b) assisting "push and pull" mode, c) counter "push and pull" mode and d) "push and pull" mode with patient exhaling upwards.

During all experiments R 134A tracer gas was dosed in the air exhaled by the breathing thermal manikin used to simulate the sick patient. The dosed concentration of tracer gas was kept the same for all tested cases. The tracer gas was used to simulate airborne droplets and droplet nuclei of less than 2 µm aerodynamic diameter that may carry one or many pathogens, (Camargo-Valero et al. 2011). The exhaled air from the manikin (doctor) was also heated (to 39 °C) to ensure a density close to that of air exhaled by a human being. In order to avoid transport of tracer gas (R 134A) from the surrounding hall, the experimental chamber was kept slightly over-pressurized at 1.6 ± 0.2 Pa during all measurements.

The tracer gas concentration was measured with two sets of multi gas sampler and analyzer based on the photo acoustic principle at 10 points (Figure 1): 1) in ventilation supply, 2) in exhaust over sick patient (SP), 3) in exhaust over the exposed patient (EP), 4) at the mouth of the doctor, 5) at the mouth of the exposed patient, 6) at the centre of the room 1.7 m above the floor, 7) at the centre of the room 1.1 m above the floor, 8) at the centre of the room 0.1 m above the floor, 9) close to the feet of the sick patient 1.7 m above the floor, 10) close to the feet of the sick patient 1.1 m above the floor, Figure 1. Neither the manikin simulating the doctor nor the heated dummy (exposed patient) was breathing. The sampling tube of R 134A was placed at the mouth 0.005 m away. As reported in the literature the tracer gas concentration measured in this way is equal to the tracer gas concentration in the air inhaled by the breathing thermal manikin, (Melikov and Kaczmarczyk 2007).

2.1 Experimental Procedure

At the start of the experiments both thermal manikins and the dummy were switched on. The doctor was either standing upright or was sitting in a chair. All measurements commenced after steady-state conditions were achieved, i.e. steady concentrations at centre of room and in both TV

exhausts (located at the ceiling). After reaching a steady state, 15 sampled values for each measurement point were acquired.

Temperature was measured throughout the experiments and after that a mean value was calculated for all the measurement locations.

2.2 Analyses of Results

The obtained tracer gas concentration data were normalized to the value of 3 ACH, 6 ACH and 12 ACH without the HBIVCU operational:

$$\epsilon = (C_m - C_s)/(C_{m(3ACH)} - C_{s(3ACH)}) \tag{1}$$

$$\epsilon = (C_m - C_s)/(C_{m(6ACH)} - C_{s(6ACH)}) \tag{2}$$

$$\epsilon = (C_m - C_s)/(C_{m(12ACH)} - C_{s(12ACH)}) \tag{3}$$

where, C_m – concentration acquired in the measuring location

C_s – concentration acquired in total volume ventilation supply

$C_{m(3ACH)}$ – concentration in the measuring point at 3ACH

$C_{s(3ACH)}$ – concentration in the total volume ventilation supply at 3ACH

$C_{m(6ACH)}$ – concentration in the measuring point at 6ACH

$C_{s(6ACH)}$ – concentration in the total volume ventilation supply at 6ACH

$C_{m(12ACH)}$ – concentration in the measuring point at 12ACH

$C_{s(12ACH)}$ – concentration in the total volume ventilation supply at 12ACH

3 Results and discussion

Figure 4 presents the normalized concentrations obtained at 3, 6 and 7 ACH (Eq. 1) in the case when only the background mixing ventilation operated.

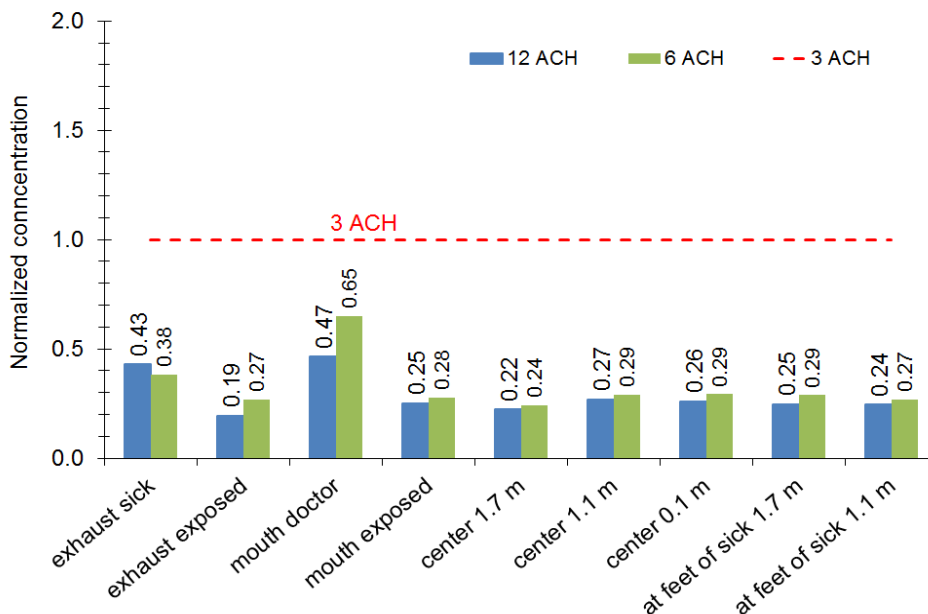

Figure 4. Normalized concentration for the cases when mixing ventilation was only used at 3, 6 and 12 ACH. Results are normalized to mixing background ventilation at 3 ACH.

The normalized concentration for 3 ACH at all point is equal to 1. The results below 1 show that the concentrations of polluted air at the measurement points were reduced compared to the concentrations obtained at 3 ACH. Values above 1 show that the measured concentrations exceeded the concentrations obtained at 3 ACH in the same points. The results for 6 and 12 ACH were much lower than 1 which showing that the exposure to exhaled air was significantly reduced when ACH

was increased. The difference between the measured concentrations for the two conditions of 6 and 12 ACH wasn't significant. Exception was the result for the mouth of the doctor, which was significantly higher for 6 ACH compared to at 12 ACH (Figure 4).

The three operation modes of HBIVCU, namely the pull, the "push and pull" and the counter "push and pull" modes were tested when the doctor was standing near the head of the sick patient breathing sideways. The "push and pull" mode was tested also when the patient was breathing upwards. The results are presented in Figure 5. The measured concentrations were normalized to the concentrations obtained for 3 ACH, Eq. (1), for 6 ACH, Eq. (2) and for 12 ACH, Eq. (3).

The concentrations obtained for the pull and the "push and pull" operation modes of the HBIVCU when the patient was breathing sideways were the lowest compared to mixing ventilation alone at 3, 6 and 12 ACH, Figure 5. In the pull mode the side slots managed to effectively evacuate the exhaled air from the sick lying patient and reduce the exhaled air concentration in the whole space. When the HBIVCUs were operated under the "push and pull" mode, the supplied air from the side slot behind the patient's head pushed the exhaled air towards the side slot of the unit which was in front of the head of the patient. Thus the localised bed ventilation performed equally well as when operated under the pull mode.

When the patient was breathing upwards the exhaled air being transverse to the flow supplied from the side slot of the box promoted mixing, Figure 5. The exhaled air collided with the supplied air and spread in all direction thus increasing the concentrations in the room. Consequently, the concentrations obtained at most measurement points in the test room when the patient was breathing upwards were higher than the concentrations obtained when the patient was breathing sideways and the unit was operated in the push or assisting "push and pull" mode.

When the HBIVCUs were operating at counter "push and pull" mode and the patient was breathing sideways, the measured concentrations were similar to those for the "push and pull" operation mode where the patient was breathing upwards, Figure 5. The side slot supplied air toward the face of the sick patient, which resulted in enhanced mixing with the exhaled air.

Under the "push and pull" mode when the patient was breathing upwards and the counter "push and pull" mode – when the patient was breathing sideways against the supplying slot the contaminant levels in the room were comparable to mixing alone at 6 and 12 ACH due to enhanced mixing, Figure 5b and 5c. The concentration at the mouth of the doctor was always significantly lower and close to zero. For the exposed patient the exposure when the unit was operated under the pull or assisting "push and pull" mode was close to zero compared to mixing alone at 3, 6 or 12 ACH. However when the counter "push and pull" was tested or when the sick patient was breathing upwards, the exposure of the second patient (exposed patient) was similar to that under 6 ACH mixing alone or slightly higher compared to 12 ACH and mixing alone, Figure 5b and 5c. Installing sensors at the units which can track the position of the sick patient's head is crucial for the capturing efficiency of the HBIVCU. When the patient turns upwards, lying on back, the fans in the unit can be automatically turned to "pull" mode of operation: both side slots exhausting, Figure 5. When the patient is positioned sideways then the "assisting "push and pull" mode" can be used to assist in capturing the exhaled air, Figure 5.

The beneficial performance of the unit to reduce the exposure of the medical staff and occupants to exhaled air might be adversely affected when the doctor seats on the bed or leans over the patient. However this needs to be further studied. There may be a possible risk from the box being jammed by accidentally sucking on the bed lining or being blocked by side rails of the bed. This issue can be solved by raising a bit the exhaust opening of the unit few centimetres over the bed and incorporating special holding "clamps" that can use the rail as an advantage to attach to the hospital bed. Noise and vibration from the fan incorporated in the box should be considered as well (the unit can be covered in noise "damping" material, low frequency noise fan can be used, special rubber made "clamps" for attachment of the unit to the patient's bed can be utilized, etc.).

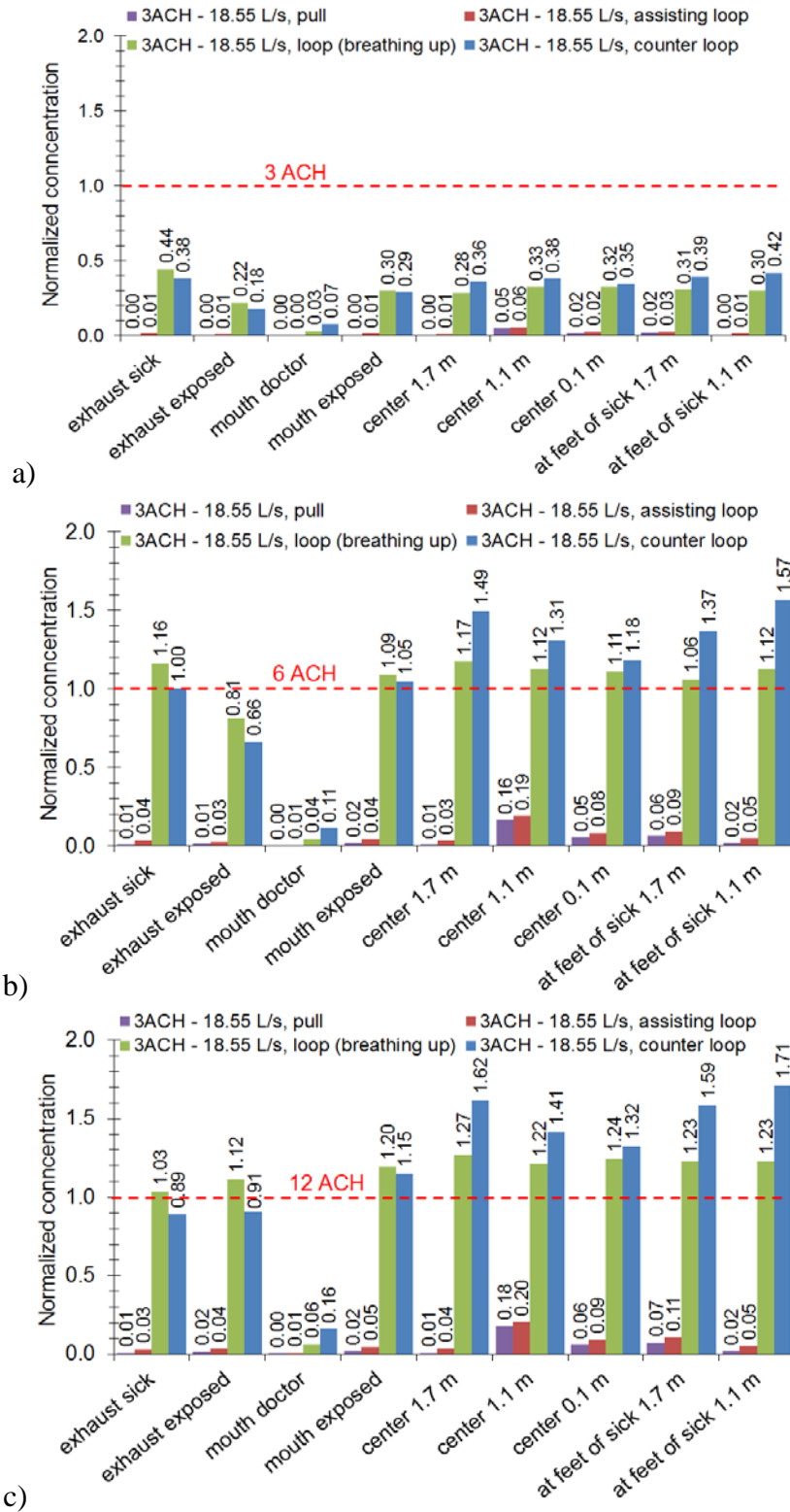

Figure 5. Normalized concentration for HBIVCUs installed at the two patients' beds, operated at 18.55 L/s in conjunction with mixing ventilation at 3 ACH. Results are normalized to a) mixing alone at 3 ACH, b) mixing alone at 6 ACH and c) mixing alone at 12 ACH.

4 Conclusion

With mixing ventilation alone and doctor standing near the head of the sick patient the exposure to air exhaled by the patient was highest at 3 ACH and decreased with increasing of the ventilation rate. The exposure of the doctor and the exposed patient was drastically reduced when the HBIVCU were operated under the pull mode or the assisting “push and pull” mode. The background room concentrations were the lowest for assisting “push and pull” and pull mode of operation. For HBIVCUs counter “push and pull” mode and “push and pull” mode of operation when the patient was breathing upwards, the exposures and the concentrations in the room were higher than under pull mode or assisting “push and pull” mode. It was the same as under 12 ACH without HBIVCU.
“push and pull” “push and pull”

5 Acknowledgements

This research was supported by the Danish Agency for Science Technology and Innovation. Project No. 09-064627.

6 References

- A.K. Melikov and J. Kaczmarczyk, 2007, *Indoor air quality assessment by a breathing thermal manikin*, Indoor Air 17 (1). pp.50-59.
- A.K. Melikov, Z.D. Bolashikov, E. Georgiev, 2011, *Novel ventilation strategy for reducing the risk of airborne cross infection in hospital rooms*, In: Proceedings of Indoor Air 2011, Austin, Texas, USA, paper 1037.
- A. Streifel, 1999, *Hospital Epidemiology and Infection Control*, 2e., Chapter 80, Lippincott Williams & Wilkins, Philadelphia, USA.
- C.B. Beggs, K.G. Kerr, C.J. Noakes, E.A. Hathway, P.A. Sleight, 2008, *The ventilation of multiple-bed hospital wards: Review and analysis*, American Journal of Infection Control 2008, vol. 36, No. 4, pp. 250-259.
- C.E. Hyldgaard, 1994, *Humans as a source of heat and air pollution*, In: Proceedings of ROOMVENT '94, 4th International Conference on Air Distribution in Rooms, Krakow, Poland, pp. 414-433.
- D.A. Edwards, J.C. Man, P. Brand, J.P. Katstra, K. Somerer, H.A. Stone, E. Nardell, G. Scheuch, 2004, *Inhaling to mitigate exhaled bioaerosols*, PNAS, vol.101, No. 50, pp. 17383-17388.
- E.C. Cole and C.E. Cook, 1998, *Characterization of infectious aerosols in health care facilities: An aid to effective engineering controls and preventive strategies*, Occupational Health and Industrial Medicine, vol. 39, Issue 5, pp. 213.
- K.C. Wong and K.S. Leung, 2004, *Transmission and Prevention of Occupational Infections in Orthopaedic Surgeons*, Journal of Bone & Joint Surgery, American Volume, vol. 86, issue 5, pp.1065-1077.
- M.A. Camargo-Valero, C.A. Gilkeson, C.J. Noakes, 2011, *Tracer-gas as a surrogate method for tracking airborne pathogen transport in indoor environment*, Proc. Indoor Air 2011, a586 4.
- M. Nicas, W.W. Nazarof., A. Hubbard, 2005, *Toward understanding the risk of secondary airborne infection: emission of respirable pathogens*, Journal of Occupational and Environmental Hygiene; 2: 143-54.
- V. Kaushal, P.S. Saini, A.K. Gupta, 2004, *Environmental Control Including Ventilation in Hospitals*, JK Science, vol.6, No 4, pp. 229-232.
- X. Xie, Y. Li, 2006, *How far respiratory droplets move in indoor environments?*, Proceedings Healthy Buildings: 309-14.
- Y. Li, G. M. Leung, J. W. Tang, X. Yang, C. Chao, J. Z. Lin, J. W. Lu, P. V. Nielsen, J. Niu, H. Qian, A.C. Sleight, H.-J. J. Su, J. Sundell, T. W. Wong, P. L. Yuen, 2007, *Role of ventilation in airborne transmission of infectious agents in the built environment – a multidisciplinary systematic review*, Indoor Air, v. 17 (1), pp. 2-18 (17).