

MISSION STATEMENT AND MANAGEMENT OF PRIVATE TERTIARY  
RELIGIOUS INSTITUTIONS IN EASTERN AND SOUTHERN AFRICA

by

HUDSON EDDIE KIBUUKA

Submitted in accordance with the requirements

For the degree of

DOCTOR OF EDUCATION

In the subject

EDUCATIONAL MANAGEMENT

at the

UNIVERSITY OF SOUTH AFRICA

PROMOTER: PROF GM STEYN

JUNE 1998

\*\*\*\*\*

DECLARATION

I declare that *Mission Statement and Management of Private Tertiary Religious Institutions in Eastern and Southern Africa* is my own work and that all the sources that I have used or quoted have been indicated and acknowledged by means of complete references.

Hudson E. Kibuuka



378.04 KIBU



0001725241

## ACKNOWLEDGEMENTS

For the successful completion of this study I am indebted to the following who assisted in making it possible:

- The Eastern Africa Division of Seventh-day Adventists for providing me the opportunity to and permission to do this study.
- My promoters beginning with Prof D. C. Badenhorst with whom I started this study, Prof. C Van Wyk and then eventually Prof G. M Steyn for their persistent assistance, guidance, inspiration, encouragement and advice throughout the study.
- Prof E. M. Lemmer for editing and checking language usage of the draft to make it meaningful to the readers.
- The library UNISA library staff as well as the staff of the University of Zimbabwe staff for the assistance and particularly the UNISA subject librarian for suppling the required literature and publications.
- All the respondents from the various institutions, ministries of education and elsewhere for assisting in providing information on the subject of study.
- My wife Rosette and children Ham, Elmer Enoch and Renita for being understanding during the time of study when they missed much of the husband's and father's attention and for their moral and practical support, and prayers.
- Lastly but most important to God for providing me with good health, strength and means to be able to do this study.

## SUMMARY

The region of Eastern and Southern Africa has recently experienced an unprecedented development of private tertiary institutions. Most of these institutions are established by religious organisations which, since the inception of education, have been involved in operating educational institutions of lower levels. Although referred to as private institutions, which by definition would imply funding other than the government sources, these private institutions find themselves, at times requesting the government to fund their development as well as their operations.

This study sought to investigate if these private religious institutions have unique *raison d'être* expressed in the form of mission statements. The study also investigated the nature of their management and the management structures in practice.

The literature reviewed indicated that private religious institutions have a unique mission based on their basic concept of education and their world view. They seek to pursue and inculcate specific values. Operating in a competitive environment, however, in which their competitors do receive funding from the government makes the private institutions vulnerable to hardships.

The study was conducted using qualitative research approach in three countries, namely Kenya, Uganda and Zimbabwe; involving all degree granting recognised private religious institutions in the sample and focussing on the management. The respondents were chosen by elite purposive and snowball sampling. The main data collection method was the interview. However, document analysis, observations, and a questionnaire were also used.

The findings from the data indicate that private religious institutions have unique missions although they are, at times, not expressed in the form of mission statements. As

a result some of the stakeholders, including those involved in management, don't get to know what their institutions' missions are.

The study concludes by emphasising the development of clear mission statements involving the stakeholders in the process and having the mission statements widely disseminated. It is also recommended that training in management is important for the managers of the institutions at the various levels. A model of management is proposed for streamlining the management of the institutions considering the requirements of the national governments as well as those of the religious proprietors.

#### KEY TERMS:

Educational Management, Tertiary Education, Religious Educational Institutions, Vision, Mission Statement, Strategic Planning, Eastern and Southern Africa, Values, Goals, *Raison D'etre*, Indoctrination, Denomination, Private Education, Affiliation, Accreditation, Participatory Management, Charter, Quality, University, Sense of Mission.

## CONTENTS

	DECLARATION.....	i
	ACKNOWLEDGEMENTS.....	ii
	SUMMARY.....	iii
	CONTENTS.....	v
	LIST OF FIGURES.....	xii
	LIST OF TABLES.....	xiii
	ABBREVIATIONS.....	xiv
Chapter 1	INTRODUCTION.....	1
	1.1 General Orientation.....	1
	1.2 Factors Leading to the Problem.....	2
	1.3 Background to the Study.....	4
	1.4 Statement of the Problem.....	5
	1.5 Aims of the Study.....	6
	1.6 Delimitation of the Field of Study.....	7
	1.7 Definition of Terms.....	8
	1.7.1 The term “Mission”.....	8
	1.7.2 The terms “Institution” and “Organisation”.....	9
	1.7.3 The term “Religious Education”.....	10
	1.7.4 The terms “Board” and “Board of Trustees”.....	10
	1.7.5 The terms “Leadership”, “Management”, “Administration” and “Governance”.....	11
	1.7.6 The terms “Denomination”, “Church” and “Religion”.....	15
	1.7.7 The terms “Accreditation” and “Chartering of Institutions”.....	16
	1.7.8 The term “Chief Executive”.....	16
	1.7.9 The term “Stakeholder”.....	17
	1.7.10 The term “Articulation”.....	17
	1.7.11 The term “Isms”.....	17
	1.7.12 The term “Tertiary Education”.....	18

1.8	Research Methodology.....	18
1.9	Limitations of the Study.....	19
1.10	Outline of Chapters.....	21
<b>Chapter 2.</b>	<b>EDUCATIONAL MANAGEMENT AND MISSION STATEMENT.....</b>	<b>24</b>
2.1	Introduction.....	24
2.2	General Review.....	24
2.3	Educational Management.....	25
2.3.1	Scope of Educational Management.....	27
2.3.2	History of Educational Management.....	28
2.3.3	Tasks of Educational Management.....	29
2.3.4	Policy Formulation in Educational Management.....	31
2.4	Private Education.....	35
2.4.1	History of Private Education.....	36
2.4.2	Management and Control of Private Education.....	39
2.5	Religious Private Education.....	41
2.5.1	History of Religious Private Education.....	42
2.5.2	Management and Control of Religious Private Education.....	43
2.5.3	Management of Tertiary Religious Private Education.....	45
2.6	Educational Management in Kenya, Uganda and Zimbabwe.....	47
2.6.1	Educational Management in Kenya.....	48
2.6.2	Educational Management in Uganda.....	55
2.6.3	Educational Management in Zimbabwe.....	58
2.6.4	Summary of Educational Management in Kenya, Uganda and Zimbabwe...	68
2.7	Vision, Mission and Mission Statement.....	68
2.7.1	Vision.....	69
2.7.2	Mission and Mission Statement.....	73
2.7.2.1	Mission Statement Formulation.....	78
2.7.2.2	Mission Statement Articulation.....	82
2.7.2.3	Components of a Mission Statement.....	83

2.7.3	The Role of Mission Statements in Institutional Management.....	87
2.7.4	The Need, Conditions for and Review of Mission Statements in Institutional Management.....	90
2.8	Summary.....	95
<b>Chapter 3.</b>	<b>QUALITATIVE RESEARCH METHODOLOGY AND THE RESEARCH DESIGN.....</b>	<b>98</b>
3.1	Introduction.....	98
3.2	Qualitative Research Methodology.....	98
3.2.1	General Orientation.....	101
3.2.2	Data Gathering Methods.....	102
3.2.3	Data Analysis Techniques.....	105
3.2.4	Trustworthiness and Authenticity of the Research Results.....	108
3.2.5	Ethical Issues.....	111
3.2.6	Data Presentation.....	114
3.3	Design of Present Study.....	116
3.3.1	Introduction.....	116
3.3.2	Choice of Method.....	116
3.3.3	Researcher Effects.....	117
3.3.4	Statement of Subjectivity, Researcher's Own Experiences, Values and Training.....	118
3.3.4.1	Researcher's Training and Experience.....	119
3.3.4.2	Researcher's Values.....	120
3.3.5	Population and Sample.....	120
3.3.6	Access and Entry.....	122
3.3.7	Data Collection.....	124
3.3.7.1	The Interview.....	125
3.3.7.2	Document Analysis.....	129
3.3.7.3	Observation.....	131
3.3.7.4	The Questionnaire.....	132



3.3.8	Data Analysis.....	132
3.3.9	Reliability and Validity.....	134
3.3.10	Ethical Issues in the Current Design.....	136
3.3.11	Trustworthiness in the Current Design.....	137
3.4	Summary.....	138
Chapter 4.	RESEARCH FINDINGS: MANAGEMENT OF PRIVATE RELIGIOUS TERTIARY INSTITUTIONS.....	141
4.1	Introduction.....	141
4.2	Categories Identified.....	142
4.2.1	The History and Nature of Private Religious Tertiary Institutions.....	142
4.2.1.1	The Nature of Private Religious Tertiary Institutions.....	143
4.2.1.2	Historical Background of Private Religious Tertiary Institutions.....	151
4.2.2	The Characteristics of Private Religious Tertiary Institutions.....	153
4.2.2.1	Ownership of the Private Religious Tertiary Institutions.....	153
4.2.2.2	Denominational Relationships of the Private Religious Tertiary Institutions.....	155
4.2.2.3	Size of Private Religious Tertiary Institutions.....	156
4.2.2.4	Residential Versus Non-Residential Private Religious Tertiary Institutions	158
4.2.3	Relationships with Different Sectors of Society.....	159
4.2.3.1	Relationships within the Institutions.....	160
4.2.3.2	Relationships with the Community.....	161
4.2.3.3	Relationships with the Government.....	161
4.2.3.4	Relationships with Public Universities.....	166
4.2.3.5	Relationships with Other Private Tertiary Institutions.....	167
4.2.4.	Funding of Private Religious Tertiary Institutions.....	169
4.2.4.1	Sources of Institutional Funding.....	169
4.2.4.2	Funds from Government.....	172
4.2.4.3	Accountability.....	175
4.2.5	Accreditation of Private Religious Tertiary Institutions .....	176

4.2.5.1	Levels of Government Recognition of Private Institutions.....	178
4.2.5.2	Procedures for Recognition of Private Institutions.....	179
4.2.5.3	External Accreditation and Affiliation of Private Institutions.....	182
4.2.6	Management Structure of Private Religious Tertiary Institutions.....	183
4.2.6.1	Management at the Government Level.....	184
4.2.6.2	Management by the Foundation Body.....	187
4.2.6.3	Institutional Councils of Governing Boards.....	191
4.2.6.4	Management at the Institutional Level.....	195
4.2.7	Educational Basic Concept of the Different Religious Persuasions.....	201
4.2.7.1	Educational Basic Concept of the Catholic Church.....	201
4.2.7.2	Educational Basic Concept of the Anglican Church.....	202
4.2.7.3	Educational Basic Concept of the Seventh-day Adventist Church.....	203
4.2.7.4	Educational Basic Concept of the Muslim Faith.....	205
4.2.7.5	Educational Basic Concept of the United Methodist Church.....	206
4.2.7.6	Educational Basic Concept of the Nazarene Church.....	207
4.3	A Model for Management of Private Religious Tertiary Institutions.....	209
4.4	Summary.....	212
Chapter 5.	RESEARCH FINDINGS: MISSION AND MISSION STATEMENTS OF RELIGIOUS TERTIARY INSTITUTIONS.....	216
5.1	Introduction.....	216
5.2	Categories Identified.....	216
5.2.1	Mission and Mission Statement.....	217
5.2.1.1	Mission Statements.....	218
5.2.1.2	Types of Mission Statements.....	240
5.2.2	Mission Statement Development.....	241
5.2.3	Mission Statement Reformulation.....	247
5.2.4	Mission in the Practical the Life of an Institution.....	249
5.2.5	Dissemination of Institutional Mission.....	254
5.2.6	Mission and the Curriculum of an Institution.....	256

5.2.6.1	Core Curriculum.....	257
5.2.6.2	Ideologies and the Curriculum.....	258
5.2.7	Aspects of the Mission of Private Religious Tertiary Institutions.....	261
5.2.8	The Influence of Mission on Management of the Private Religious Tertiary Institutions.....	269
5.3	Summary.....	273
Chapter 6	SUMMARY, CONCLUSIONS AND RECOMMENDATIONS.....	276
6.1	Introduction.....	276
6.2	Summary.....	277
6.3	Conclusions and Recommendations from the Study.....	289
6.3.1	Summary of the Recommendations.....	293
6.3.2	Recommendations for Further Research.....	295
6.4	General Conclusion.....	296
	REFERENCES.....	298
	APPENDICES.....	318
Appendix A1	Ministry of Education Headquarters Organisational Structure - Kenya.....	318
Appendix A2	Old Ministry of Education Organisational Structure - Uganda.....	319
Appendix A3	Proposed (New) Ministry of Education Organisational Structure - Uganda.....	320
Appendix A4	Ministry of Higher Education Top Organisational Structure - Zimbabwe.....	323
Appendix B1	Temporary Permit to Conduct Research - Kenya.....	324
Appendix B2	Research Permit to Conduct Research - Uganda.....	325
Appendix B3	Research Permit to Conduct Research - Zimbabwe.....	326
Appendix B4	Letter of Introduction from University of South Africa.....	327

Appendix B5 Letter Seeking an Appointment to Conduct an Interview.....	328
Appendix C1 Letter Accompanying and Introducing the Questionnaire.....	329
Appendix C2 The Questionnaire.....	330
Appendix D The Interview Schedule.....	338
Appendix E Newspaper Excerpts on Private Tertiary Institutions.....	339

## LIST OF FIGURES

Figure 2.1	Knotts Sequence of Realising Vision.....	72
Figure 2.2	The Ashridge Mission Model.....	77
Figure 3.1	Qualitative Research Traditions Classified by Type of Phenomena Investigated.....	100
Figure 4.1	A Model for Management of Private Religious Tertiary Institutions.....	210

LIST OF TABLES

Table 4.1	Presentation of Institutions Involved in the Study.....	143
Table 4.2	Levels of Accreditation of Public and Religious tertiary institutions by country by end of 1997.....	146
Table 4.3	Summary of the Responses to the Questionnaire.....	148
Table 5.1	Summary of Aspects on Mission and Mission Components.....	263

## ABBREVIATIONS

AAU	Association of African Universities
ACTEA	Accrediting Council for Theological Education in Africa
AMECEA	Association of Member Episcopal Conference of Eastern Africa
IIEP	International Institute of Educational Planning
KANU	Kenya African National Union
NGO	Non-Governmental Organisation
SDA	Seventh-Day Adventists
SWOT	Strengths, Weaknesses, Opportunities, Threats
UDI	Unilateral Declaration of Independence
UNESCO	United Nations Educational, Scientific, and Cultural Organisation
USA	United States of America

**CHAPTER 1****INTRODUCTION****1.1 GENERAL ORIENTATION**

In many countries in Eastern and Southern Africa education was introduced by churches or religious bodies (Maphosa 1996: 1). Saayman (1991: 29) states the same fact when he says that its shortcomings notwithstanding, the immense importance of the role played by mission schools is in Africa self-evident. He contends that many African leaders had their early education in mission schools. Maphosa (1996: 1) goes on to say that the establishment of tertiary institutions and universities is a natural consequence of that trend which was started by the missionaries.

This probably explains the move to establish private religious universities in a number of these countries in the current decade. Examples of this development may be seen in Uganda, Kenya and Zimbabwe where private religious universities have been established and have been or are about to be chartered (recognised) by the respective governments. In addition, there are other post-secondary institutions run by churches including theological colleges, technical colleges, teacher's colleges and others which do not offer programs leading to award of degrees. Most of these institutions, although not receiving financial support from governments, do receive some moral support. However, in a few instances questions are raised about the establishment of private universities in particular and their recognition by governments. Further questions arise when such institutions accept financial assistance from their respective governments.

The countries of Kenya, Uganda and Zimbabwe and some of others in the region have also been characterized by government autonomous control over tertiary education probably based on their political ideologies which were hitherto not very liberal. In recent years, however, due to economic hardships experienced and the move towards



liberalism and democracy, many of the countries in the region have tended to privatise not only education but also other services which have been operated by governments over the years. This therefore, coupled with what Maphosa (1996: 1) calls a natural consequence of missionary involvement in early education are believed to be the factors that have led to the moves to establish private tertiary institutions in the region.

There are and have been questions raised about the mission of these institutions as to whether they are not basically established for the sake of propagating their religious beliefs and indoctrination as Smith (1987: 7) asserts may have been the case in American history. However, as Nord (in Lewis 1996: 103) argues, unless there is secularization balanced by religion or exposure to both secular and religious facts, indoctrination cannot be avoided. These two authors seem to imply that a balance in education between religious education indoctrination and secularisation is important. The question of *raison d'etre* (reason for existence) therefore ensues for these institutions (Fowler 1994: 37).

## **1.2 FACTORS LEADING TO THE STUDY**

The mission of an institution, usually presented in the form of a mission statement, defines the central *raison d'etre* of the institution. Its formulation is one of the sub-tasks of educational management. According to Davies (1986: 91) and Van der Westhuizen (1991: 144) a mission statement is a statement concerning the nature of the school (institution) as an organisation which is used as a public relations tool and is not necessarily what it is striving to be. It focuses the attention and rallies the energies of an entire institution around its primary purpose (Rasi 1994: 3). Other authors such as Kotler and Murphy (1981: 478), Rogus (1990: 6) and Torgerson (1991: 477) include what the institution is struggling to become and its vision of itself and the future as parts of a mission statement. There is, therefore, a difference among

different authors about what a mission statement should contain. However, regardless of these differences of opinion, the statement remains an important planning document according to Harvey (1994: 51) and Detomasi (1995: 31) describing the unique *raison d'être* of an institution.

In practice there appears to be no unique *raison d'être* for some religious institutions when compared to that of public institutions. According to Brantley (1995: 3), many so-called Christian schools and colleges mindlessly adopt models of excellence which are normatively defined by a secular world. This statement seems to imply the apparent lack of a unique purpose of existence in some of those institutions. Under such circumstances, educational managers occasionally find themselves in situations in which the expectations of their responsible or founding bodies (religious organisations) may conflict not only with their own but also at times with the actual practice in the institutions let alone simply conforming to those of the public institutions.

Everard and Morris (1990: 256) when discussing the necessity of a core mission for any organisation argue that it is not easy to answer this question or to find a unanimous answer. Core mission or reason for being, they argue, is generally assumed rather than debated and explicitly defined.

Core mission being that hard to define and yet it is of significance in relation with the philosophy and policy of any organisation implies that the latter are also not clearly defined. Furthermore, this in turn affects the goals, aims, and objectives of an organisation which emanate from the core mission or mission statement. This scenario may result in a lack of direction.

Another apparent problem, as far as religiously affiliated institutions are concerned, is the assumption that managers of such institutions are aware of the core missions of

their founding religious body and hence these managers are able to incorporate them into their institutional mission statements. On the other hand they may not have such knowledge and hence may manage the institutions in a way which differs from the expectation of the founding religious body and lose the religious core mission for which they were established.

In the light of the above, Cochran and David (1986: 108) agree that research focussing on the mission statement is limited. This emphasises the need for further research to improve management's understanding of these important management documents.

### **1.3 BACKGROUND TO THE PROBLEM**

As Brantley (1995: 3) contends some religious institutions are difficult to differentiate from the public institutions in practice. This may be a result of their own acquiescent practice or, as some have claimed, due to the control governments exert over these institutions indirectly or directly (Furst 1992: 114; Ball 1979: 6; Winter 1987: 249, 250; Konrad & McNeal 1984: 37,38). Factors that intensify this state of affairs include those that have to do with management and those that have to do with finances.

Regarding management, Herman (1989: 83) states that principals must know where they are going and how to get there, which implies that if they are unclear the organisation ends up in chaos or exhibits a lack of direction. On the other hand, good management without mission statement, according to Kohler (1985: 349), is very difficult. Instead, as Strydom (1988: 3) states, institutions need leaders who can turn their visions into reality by managing and leading well. Management and leadership, therefore, are keys in propelling institutions according to their *raison d'etre*.

As far as finances is concerned, economic hardships have forced many private institutions to begin requesting for grants and assistance from governments. As Yarrington (1981: 20) states, in the case of community colleges the economy has become a dominant factor in determining how colleges would be financed to the extent that finances has become a dominant factor in determining the mission of a college. As a result, Winter (1987: 246) states that such colleges no longer take a radically anti-secular stance since 15-20% of their operating budget may be received indirectly from various forms of grants and loan facilities. Lewis (1984: 24) discussing the diminishing church subsidies says that "already there is a great competition for the church's dollars." He, however, goes on to say that whether or not the colleges will obtain an adequate share of those dollars hinges on the ability to convince the leaders and constituencies that the mission for which the colleges were established is being fulfilled and is still valid. Jaqua (1977: 17,24) and Reynolds (1980: 14) argue that government control comes as a result of government financing of private religious institutions. Furthermore, that the latter have to sacrifice their independence and *raison d'etre* to qualify for such money.

While these factors appear to be affecting the core reason for existence of colleges and universities in different parts of the world, in some countries of Eastern and Southern Africa there seems to be an unprecedented move to establish and recognise private religious colleges and universities. This raises the question whether such institutions have a unique mission or not.

#### **1.4 STATEMENT OF THE PROBLEM**

The purpose of this study was to attempt to find answers to the problem as observed in practice and to answer the following question: What is the role of institutional management in the formulation of and implementation of an institutional mission statement of religious tertiary institutions?

The study also attempted to find justification for the establishment of such institutions by providing answers to the question: Is there a difference, in practice, between the mission of religious tertiary institutions and public institutions?

Specifically, the study sought answers to the following questions:

- (i) What is the role of institutional management in the formulation of mission statements of their institutions?
- (ii) To what extent does management implement the missions of their institutions in practice?
- (iii) What is the influence of the mission of religious organisations on those of their educational institutions?
- (iv) Is there uniqueness of mission and therefore a rationale for establishing religious tertiary institutions?

## **1.5 AIMS OF THE STUDY**

The aims of the study were:

- (i) to investigate the role of management at institutional level in the formulation of mission statement;
- (ii) to investigate the success of management in the implementation of the various tenets of the mission statement;
- (iii) to survey the level of awareness and articulation of the institutional mission statement by different levels of management including religious leaders, board members and institutional leaders and the influence, if any, of the mission of religious organisations on their educational institutions;
- (iv) to investigate the rationale for establishing religious tertiary institutions and to study the effect of articulation of mission statement on the management of the

institutions.

## **1.6 DELIMITATION OF THE FIELD OF STUDY**

The study investigated the topic in three countries in Eastern and Southern Africa: Kenya, Uganda and Zimbabwe. These countries were chosen, first of all, because of their overt liberal policy towards the establishment and recognition of private universities and the ensuing upsurge in the number of private religious institutions in those countries. Kenya at the start of the study had three private religious chartered universities. This number increased during the course of the study to four. Uganda had one and Zimbabwe had two chartered private religious universities at the start of the study. In addition, in each of these countries there are other private religious universities in the process of seeking recognition.

Secondly, there is no evidence that a similar problem has been investigated over the same population covering the same countries. Cognisance has been taken of the study by Treister (1992: 130) who conducted an ethnography which ethnographically examined the role of mission as the encompassing and driving force operating in the school but over a different population in the USA.

Because much of the previous research on this topic has been done in the USA, much of the literature available is from the USA. The literature review, therefore, predominantly cites literature from outside the region and most particularly from the USA. Attempts, however, were made to obtain literature available on the subject from within the region and to cite works which are relevant to the subject and population of study.

The sample only included degree granting tertiary religious or religiously affiliated private institutions in the mentioned countries referred to as colleges or universities

without discrimination on religion with exception of one institution. The investigation was confined to members of managerial positions. This included chairmen of the board, other members of the board, institution heads and their deputies, and leaders of religious bodies operating these institutions.

The purpose of this study was not predictive but to understand and describe the role of mission in the management of religious private tertiary institutions in the three selected countries. While some of the findings from the study may be relevant to other institutions, it was not the intention to generalise the findings. The focus of the study was the institutions described in the sample.

## **1.7 DEFINITION OF TERMS**

A number of terms and concepts were used or referred to in the study. In some cases the terms were not used in the sense of the conventional meanings as found in the dictionary. The following is a discussion of the definitions of terms and concepts used in the study.

### **1.7.1. The term "Mission"**

In this study the term "mission", with a few exceptions when it is used to refer to a church organisation, generally refers to the French expression "*raison d'etre*". This term means the reason or justification for being or the existence of an organisation or a program (Collins 1990: 434). The term mission statement is used as an exposition of the mission of an institution. A similar idea is explicit in the definitions given by the following authors Newson and Hayes (1991: 28); Knoop (1986: 12); Cochran and David (1986: 109); Evans (1990: 10); Herman (1989: 79); and Klimoski (1991: 19, 20).

Kohler's (1985: 345) definition referring to mission as the expectations of society and those of the university itself was not the understanding of this study. However, it provided insight into the wider definition of the term mission.

### **1.7.2 The terms “Institution” and “Organisation”**

The term “institution” was generally used to refer to an educational institution regardless of its level. However, as has been indicated in section 1.6 the current study only examined degree granting tertiary private religious institutions. The term “institution” is, therefore used mainly to refer to religious tertiary institutions.

Religious institutions refer to those institutions which are either sponsored by or affiliated to church organisations. Private institutions refer to those institutions which do not receive direct government grants for their operations although they may receive some funds in the form of one time grants and students’ grants or donations. The latter is a subject of investigation in the current study. De Jong (1992: 20-22) outlines the following features of a religiously affiliated institution:

- private and independent with a self-perpetuating board and freedom from governmental control;
- denominational affiliation;
- residential environment;
- behavioural standards derived from their religious and ethic traditions;
- integration of faith and learning; and
- emphasis on teaching.

Certain features may not be strictly adhered to in some of the institutions in this study, such as residency and emphasis on teaching, therefore they do not necessarily form part of the definition although they give good insight into the historical background



and the changing nature of religious institutions.

The term “organisation” is used to refer to a system with established structure and conscious planning with people working and dealing with each other in a coordinated, cooperative manner in order to accomplish recognised goals (Passi *et al.* 1996: 1).

Used in this sense it may also refer to educational institutions. It is also used in quotations from different authors in which case the original meaning of the term was retained.

### **1.7.3 The term “Religious Education”**

The term “religious education” does not refer to the teaching of religious subjects in schools but refers to a system or institution that is affiliated to a religious organisation.

### **1.7.4 The terms “Board” and “Board of Trustees”**

The terms “Board” or “Board of Trustees”, refer to the managers of institutions or their governance and were used interchangeably. In addition the term “university council” or simply the “council” was also used to refer to the same bodies. The term council is another common term used to refer to the governing boards of universities in the region particularly those which have government recognition. Some institutions make a distinction, however, between the terms “Board of Trustees” and “Council”. The former refers to a body of owners of an institution and the latter refers to those entrusted with governance of the institution by the owners. Where this is the case, it is highlighted as such.

### **1.7.5 The terms “Leadership”, “Management”, “Administration” and “Governance”**

The terms “leadership”, “management”, “administration”, and “governance” are used a great deal in literature in connection with the subject of the study. At times these terms are used interchangeably. It is therefore requisite to identify their differences and to define how they are used in this study.

Bennis and Nanus (1985: 17) refer to leadership as the wise use of power, power being the basic energy needed to initiate and sustain action or the capacity to translate intention into reality and sustain it. Referring to intention as vision leadership gives an organisation a vision and the ability to translate that vision into reality. “Leading is influencing, guiding in direction, course, action opinion”. Leaders are often referred to as being future oriented. The following may be referred to as the five essential skills of leaders as identified by Bennis and Nanus (1985: 21; 63; 66-67 ) after a study of ninety leaders:

1. The ability to accept people as they are, not as one would like them to be;
2. The capacity to approach relationships and problems in terms of the present rather than the past;
3. The ability to treat those who are close to oneself with the same courteous attention extended to strangers and casual acquaintances;
4. The ability to trust others even if the risk seems great;
5. The ability to do without constant approval and recognition from others.

Managing on the other hand, according to Bennis and Nanus (1985: 21) means “...to bring about, to accomplish, to have charge of or responsibility for, to conduct”.

Management has to do with “knowing how”. According to Bennis and Nanus (1985:

40, 218), management has to do with a lot of exchanges or a bunch of agreements, “...you do this for that reward”, resulting, at best, in compliance or at worst, in spiteful obedience.

The difference between leadership and management is summed up, according to Bennis and Nanus (1985: 21) and Covey (1990: 101) into activities of vision and judgement, which comprises effectiveness; versus activities of mastering routines, which comprises efficiency. It is “know why” versus “know how”. Using the metaphor of climbing the wall of success, management is climbing the wall; leadership is determining whether the ladder is leaning against the right wall. Covey (1990: 101) refers to management as asking how best to accomplish certain things and leadership as asking what are the things to be accomplished.

In business terms leadership is strategy formulation and entrepreneurship in which the chief entrepreneur is responsible for leading the enterprise in the right direction at the right time and keeping the organisation in a position to enjoy sustained success (Thompson & Strickland 1986: 25 ). In this particular case, however, the common term in business - General Manager - is used to refer to the leader of the enterprise.

Leadership, therefore has more to do with being visionary and doing strategic planning which involves developing a mission statement. In this study, therefore, the terms management and leadership are used interchangeably. But the connotation of leadership is more implied in the usage relating to formulation of mission statement. The study attempts to combine the efficiency as well as the effectiveness aspects of mission statement formulation and implementation.

In a similar disposition the term “administration” is more akin to management as strategy implementation (Thompson & Strickland 1986: 30). Although it is sometimes used interchangeably with either leadership, it is used mainly to refer to management.

The administrative aim of an organisation, according to Thompson and Strickland (1986: 30) is to see that:

- the chosen strategy works as well as the circumstances can allow,
- the strategic plan is implemented and executed in ways that achieve the target results and satisfy the conditions of efficiency and doing things right.

The assumption underlying the above is that the strategy has already been laid down by an act of leadership. What remains is implementation by administration.

Nevertheless, Campbell *et al.* (1983: 1; 6-8), having defined educational administration as the management of institutions designed to foster teaching and learning, enumerates the following functions of administration carried out by an administrator:

- Discerning and influencing the development of goals and policies;
- Stimulating and directing the development of programs to achieve the goals and purposes;
- Establishing and coordinating an organisation to implement the programs;
- Procuring and managing the resources needed to support the organisation and its programs;
- Representing the organisation to groups in the local or larger community and when necessary mediating among these groups, referred to as the political function; and
- Appraising the effectiveness of these operations.

Administration, therefore, besides influencing the development of goals and policies of an organisation, involves implementation. In the few cases where the term “administration” is used in the study, it is also used synonymously with the term

“management” except when it is used as a quotation in which case the original meaning is retained.

Saint (1992: 71) defines “governance” as “...the mechanisms whereby an institution incorporates the participation of relevant interest groups in defining the scope and content of its work - including the capacity to mediate among these interests when they enter into conflict - and the means whereby it demonstrates accountability to those who support it through its mission mandate and the application of its resources in pursuit of these goals.” Although the term is mainly used in association with structure, Ingalis (1987: 3); Kennedy (1991: 10); Parker (1986: 177); and Saint himself (Saint 1992: 71) use the term to refer to management or management structures. Sanyal *et al.* (1996: ii) alludes to governance structure as having to do with control and authority over the decision-making process.

Nevertheless, the “term” governance is more embracing of the structure and usually has the connotation of overseer or ownership. In this sense, therefore, the term “governance” is used primarily in the sense of overseer such as the board of governors whose responsibilities are usually to ensure the total operation of an institution. In some cases it is also used to refer to management such as the board of management also referring to the board of governance or trustees of an institution. The term “governance” is, therefore, used in this sense except where it is used as a quotation in which case the original meaning is retained.

Although the term “management” is used more frequently, all four terms - leadership, administration, management and governance are used more or less interchangeably in the study because of their closeness in meaning, their inherent differences notwithstanding. This is also, according to Van der Westhuizen’s (1991: 38-41) and Badenhorst’s (1995: 9-37), description of management as a balanced activity comprising of activities or tasks such as policy-making, planning, achieving

objectives, decision-making, coordination or organisation, communication, controlling, leading and guiding.

#### **1.7.6 The terms “Denomination”, “Church” and “Religion”**

The term “denomination” is defined as a religious group including many local churches, or a religious group or sect (Hornby 1995: 310). It usually includes all religions including Islam and other non-Christian religions.

On the other hand the term “church” is defined by Hornby ( 1995: 197) as a particular group of Christians, a Christian congregation or an organised religion. It is also used to refer to a building for public Christian worship or a service conducted in such a building. When used as a Christian congregation or organised religion it usually excludes Islam and other non-Christian religions.

The term “religion” appears to be more all-embracing when defined as “...a set of beliefs concerning the cause, nature and purpose of the universe...and often containing a moral code for the conduct of human affairs”, or institutionalised system of religious attitudes, beliefs and practices” (Merriam-Webster 1980: 969), or a particular system of faith and worship based on religious beliefs (Hornby 1995: 988) or something believed and followed strictly. In such a case all beliefs including non-Christian beliefs such as Islam may be included.

In this study all three terms are included with the generic sense of the term religion which refers to a set of beliefs, except where a term is used in a quotation or in a sense to refer to its sectarian or other meaning.

### **1.7.7 The terms “Accreditation” and “Chartering of Institutions”**

The term “accreditation” also has several meanings. Some of the meanings are designating officially, such as accrediting an envoy; making credible, authoritative or reputable; and officially declaring a system to be of the desired quality or standard (Hornby 1995: 9). In this study, however, the term is used to refer to the process of certifying an educational institution as meeting the official requirements for academic excellence curriculum, facilities, teaching staff, administration and financial viability. It is therefore used to refer to more than recognition or registration of an educational institution which at times is done without much regard to the official requirements.

The term “chartering” is also used to refer to the same process in the countries under study. In this sense the term charter is used to refer mainly to the document that results from the process which may be defined as a document outlining the formal organisation of a corporate body or a constitution. It is an authorisation document which includes the rights and privileges of the organisation. It is commonly used in countries or educational institutions which have a British background.

### **1.7.8 The term “Chief Executive”**

The term “chief executive”, although commonly used in connection with business enterprises, is used in this study in the sense it is used in the resource materials for school heads in Africa by the Commonwealth Secretariat to refer to the head of an institution (Commonwealth Secretariat 1993: 3). In this sense it is used to refer to those at the top of management of institutions also referred to as vice chancellors, or sometimes principals. The terms “chief executive”, “vice chancellor”, “principal” and “institutional leader or head” are therefore used synonymously.

### **1.7.9 The term “Stakeholder”**

Another term borrowed from business is the term “stakeholder”. It is used to refer to the individuals and groups of individuals who have an interest in a transaction. In the present study the term stakeholder is used to refer to all those persons who have an interest in the business of the institution. This would include the members of the administration, the teachers or members of faculty, the students, the parents, other employees in the schools and the former students. Others who may not have direct interest in an educational institution may include the members of the surrounding community and prospective employers. The term mainly refers to the first category of individuals and groups of individuals. These are individuals and groups who would normally be required to be represented on the management of an institution at various levels.

### **1.7.10 The term “Articulation”**

The term “articulation” is used to refer to the usage of language easily and fluently to express or present with clarity and effectiveness a concept. It is not used to refer merely to uttering words in speech. It therefore, also refers to the expression of concepts in written form not only in spoken form.

### **1.7.11 The term “Isms”**

The term “isms” is used as an acronym to refer to doctrines or philosophical ideologies either believed in or taught as systems. They include ideologies such as idealism, realism, pragmatism, existentialism, naturalism, humanism, progressivism, perennialism, social reconstructionism, essentialism and Marxism. Doctrines such as socialism and capitalism are not only taught but can represent the very strong beliefs of individuals and whole societies akin to religion and can affect the behaviour of



individuals.

### **1.7.12 The Term “Tertiary Education”**

The term “tertiary education” is used in the study to generally refer to education above the secondary school level which is ordinary level (form 4) in Kenya and Advanced level (form 6) in Uganda and Zimbabwe. The term is used more specifically, however, to refer to degree granting educational institutions which are the subject of the study.

## **1.8 RESEARCH METHODOLOGY**

A detailed description of the research methodology used for this study is covered in chapter three of this thesis. This section, however, serves as a brief introduction to the method that was used to understand the management and mission of institutions.

The various tenets of a mission statement include the purpose, clients, product or service, the market, technology, organisation, image, and management philosophy. The same were stated in a shorter form by Eager (1986: 28), who, when giving hints on how to develop a mission statement which is precise, clear and succinct, suggested three components of a mission statement: the initiator and controller, the purpose and direction, and the community to be served.

In order to investigate the topic taking into account these tenets or components of a mission statement and the various individuals involved in the management of an institution, a multi-method ‘field study’ approach of research was used which according to Dale (1984: 75) and Wolcott (1992: 21) could involve an inter-disciplinary approach to research. In this study which includes in-depth understanding of the role mission statements play in the establishment and management of religious

tertiary institutions, the qualitative approach to research was employed taking into account the various tenets of a mission statement. This included the analysis of documents of official institutional, governmental (ministries concerned) and religious bodies which relate to education; observations; interviewing "information-rich" individuals. Most of those who were interviewed were institutional administrators, officials in relevant government ministries, leaders of church or religious organisations concerned, and others who were to be selected by purposive sampling.

Analysis of the data was done inductively as the investigation of the problem was taking place with subsequent data collection contingent upon the previously collected data. This method is best suited for such an approach since it is basically an inductive study based on qualitative research methods. As soon as the data was collected, mainly on audio-tapes, the recordings were transcribed on computer. At the end of data collection the transcripts were examined for emerging patterns and preliminary themes were identified which were further examined and grouped into categories in comparison with information from literature.

Since the history of the institutions included in the sample was relatively short and their number is small, the researcher himself did all the data collection. This also helped to reduce chances of multiple subjectivity. The researcher, however, used triangulation of methods and member checks to ensure credibility (validity) and confirmability of the results.

## **1.9 LIMITATIONS OF THE STUDY**

At the beginning of this study it was assumed that all the institutions referred to have mission statements which are the subject of the study. It emerged that while all respondents emphasised the value of having a mission statement, some did not have very succinct mission statements while others provided their institution's list of

objectives for examination as their mission statements. Other documents from the institutions were easily obtainable. However, it was not as easy to obtain relevant documents from the various ministries of education and other offices concerned probably because they were still new and only recently or being established at the time of the study.

It was further assumed that the institutions had boards or councils which govern them. This was true of all the institutions that formed the sample although the researcher was not able to meet the members of the boards/councils as desired. In this regard the researcher used a questionnaire to reach the chairpersons of the governing councils who were not easily accessible for an interview.

A further assumption was that the individuals who formed the sample would be willing to participate and supply authentic information requested for the study. There were no major constraints in the study as far as entry was concerned because of the nature of the primary research respondents who were generally academicians themselves. Most of them received the researcher empathetically having themselves conducted research. However, by virtue of the nature of their work the time they could spare for the interview was rather limited. A few of the church leaders were suspicious but not to the extent of rejecting participation. However, some did not return the questionnaire and others would only allow their documents to be read in their offices and did not allow the researcher to borrow them. In such cases the researcher had to be most careful to obtain and record as much information.

A major constraint, however, was the vastness of the area covered by the study. This made it cumbersome to collect data when required as it necessitated travelling to the countries under discussion. Funding for such travel was a major factor in the obtaining of the information on time and doing iterative data collection. Conducting the research while employed was yet another factor that exerted pressure on the

researcher.

Being far from the university library was another constraint as materials took time to arrive causing some delays and hardships.

## **1.10 OUTLINE OF CHAPTERS**

The study, is reported in six chapters. The following is the outline of these chapters:

Chapter one is an introductory chapter which contains a general orientation; factors leading to the study; a background to the problem followed by the statement of the problem and aims of the study, delimitation of the study and definition of terms; and an outline of the research methodology. Assumptions and constraints during the study are also highlighted in this chapter.

Chapter two contains the review of literature available on the subjects of mission and management with particular reference to private education. This review, as proposed by Wilson and Hutchinson (1991: 269), was intended to reveal the general focus and nature of prior inquiry on the subject. Methodological problems, contradictory and unclear findings, and gaps in knowledge are also highlighted in this chapter. As typical of hermeneutic and grounded theory studies "literature review was used not to summarise the specific details of related research findings generated by quantitative methods nor to synthesise a theoretical framework but rather to specify important variables that can serve as background meanings for hermeneutic analysis and sensitising concepts in the generation of a grounded theory" (Wilson & Hutchinson 1991: 269). Literature review, however continued through the study.

Chapter three begins with literature review on qualitative research design and then gives an outline of the research design. This includes specifying the population, the

sample and sampling method, the research instruments and measures of credibility. Methods of data analysis presentation and reporting are also discussed in this chapter.

Chapters four and five present and discuss findings of the research. Chapter four discusses management in general and management of religious tertiary institutions giving the findings of the research obtained through interviews, document analysis, observation and the questionnaire on the subject of management. The chapter dwells primarily on the findings as they relate to the private religious tertiary institutions from macro to micro management and a model of management structure of private religious tertiary institutions is suggested at the end of the chapter.

This chapter also presents data on the historical background and factors that led to the development of private religious tertiary institutions as well as the educational concepts of the different churches. Moreover, problems faced by this development and the role of state and government legislation including control are discussed in this chapter.

Chapter five presents data on vision, mission and essential components of a mission statement as obtained from the respondents, and as viewed by various authors and the view proposed by the current study. The data and various tenets of a mission statement presented and discussed include types and characteristics of mission statements, the development of and reformulation of mission statements, mission dissemination and mission in practice and curriculum and mission.

Chapter six presents a general summary, the conclusions from the study and recommendations related to management of tertiary institutions and the relationship between state governments and these institutions. It is hoped that this study will provoke further research, thus the chapter includes recommendations for further study in those areas outside the scope of the current study or which arose out of the study.

This would provide further insight into the operation of private tertiary religious institutions in particular and private tertiary education in general.

## **CHAPTER 2      EDUCATIONAL MANAGEMENT AND MISSION STATEMENT**

### **2.1    INTRODUCTION**

The phenomenon of private tertiary education is still a new one in most of the region under study. As such not much literature exists about the topic within the region. However, the phenomenon is of much interest to policy makers and educational managers in the same region since there is a new interest in private tertiary education. In one of the countries of the study the government had not yet produced a mechanism of accrediting such institutions at the beginning of the study although a number of private universities were already operating in that country. The other countries had only recently established such a mechanism and recently chartered their first private universities under the provisions of the mechanism.

Religious organisations and churches are on the forefront in establishing private tertiary institutions particularly as they have had a long history of operating at a lower level of education and much of the limited literature available is produced by religious organisations. The rest of the literature related to this topic was obtained from outside of the region particularly from the United States of America where, apparently, the subject has been of interest for sometime.

### **2.2    GENERAL REVIEW**

Educational management, which became an area of study during the last half of the century, when compared to other management studies such as business management (Riffel 1978: 140, Hoy 1982: 3), is still a challenge particularly in tertiary education. Van der Westhuizen (1991: 104) discussing developments in the field of educational management quotes Nell as stating that the field only became established as a

scientific field after 1945. Campbell *et al.* (1983: 2) corroborate this. It has since then developed to become an important component of educational training. Despite the difference between educational and other forms of management Hersey and Blanchard (1982: 3, 4) argue that “Acting in their managerial capacity, presidents, department heads, foremen, supervisors, college deans, bishops, and heads of governmental agencies all do the same thing”. This argument appears to include educational managers such as college deans which could as well include college principals and university vice chancellors. They are all interested in getting things done with and through people. Working through people and yet at the same time fulfilling the desires of the organisations for which they work implies that managers ought to demonstrate the ingenuity of working with different kinds of people. They have to constantly endeavour to focus the attention of those being led on the purpose for which the institution exists. This further implies the value of a well defined mission for an institution and management who know what they are doing.

Some of the differences alluded to in the literature have to do with the different types of organisations such as religious institutions and private institutions. Literature related to these different types of organisations and levels of management was discussed in the following sections beginning with educational management.

### **2.3 EDUCATIONAL MANAGEMENT**

Van Der Westhuizen (1991: 38-41) summarises the definitions of management by Koontz and O'Donnell (1964: 1), McFaland (1974: 6), Trewatha and Newport (1976: 22), Morgan (1976: 8); and Kolde (1977: 2692) in terms of achieving objectives. Other aspects of management included in the summary, are also mentioned by Badenhorst (1995: 9-37), Everard and Morris (1990: 4) and Sanyal *et al.* (1996: 14 & 18) as a series of actions or functions: management as decision-making, deciding what and how to do it; management as co-ordination; and management as leading,



guiding, strategic planning, clarifying missions and objectives and developing. Van Der Westhuizen (1991: 41) concludes by describing management as a balanced activity involving all the above activities which Van Niekerk (1988: 3,6) refers to as a continuous cycle or simultaneous process, while Mbamba (1992: 33) contends that management tasks range from policy formulation to enforcement of decisions or implementation. Therefore, none of these approaches can either be emphasised or accepted *per se*, but all approaches contain some element of management which is absolutised.

Van Der Westhuizen (1991: 55) then describes educational management as a "specific type of work in education which comprises those regulative tasks or actions executed by a person or body in a position of authority in a specific field or area of regulation so as to allow formative education to take place." The primary function of educational management, according to Mbamba (1992: 1), is to ensure maximum utilisation of human, material and financial inputs in order to achieve educational objectives. It requires thorough training and research because lack of such training has been "...responsible for a great deal of inefficiency and ineffectiveness observed in the performance of education systems in Africa" (Mbamba 1992: 2).

In a similar vein Everard and Morris (1990: 4) contend that management in its broadest sense is about the following:

- setting direction, aims, and objectives;
- planning how progress will be made or a goal achieved;
- organising available resources (people, time, materials) so that the goal can be economically achieved in the planned way;
- controlling the process (i.e. measuring achievement against plan and taking corrective action where appropriate); and
- setting and improving organisational standards.

As is evident from the descriptions of both these authors educational management like management in the business world involves more than simply overseeing an already planned system. It includes planning, executing, evaluating and re-planning. This implies setting goals and objectives which further implies determining and cherishing a vision and mission. Matejka *et al.* (1993: 34) states that creating a vision is an essential act of leadership and explains vision as a dream of the future, which is essential in developing a mission statement. Lewis (1989: 42) and Bennis and Nanus (1985: 89) also referred to vision as a statement of an individual's mental image of the future developed by leaders based on a combination of information, knowledge, ideas, aspirations, dreams, threats and opportunities. Regarding aspirations and dreams Lewis (1989: 42) emphasises the role of management and top leadership who have to think and plan for the future direction and develop a vision which, according to Knott (1995: 127), encompasses all aspects of the institution involving all role players.

Management therefore begins from a vision of the organisation's future. It encompasses all aspects of the organisational activities and good management should include evaluation and re-planning. The next section expounds on the various aspects of management as found in the literature.

### **2.3.1 Scope of Educational Management**

As soon as two or more people are jointly performing a task together, management begins. Management is an essential part of life therefore which must be cultivated and nurtured. It is not intuitive but requires thorough training and research (Van Der Westhuizen 1991: 56; Mbamba 1992: 2). Management is one of the two main tasks in an educational institution. These are the functional tasks - having to do with the main task or the central task of educative teaching which justifies the existence of an institution, and the management task which includes decision-making, planning,

policy formulation, and goal setting.

Management, therefore, can be defined as the actions carried out in order to perform the functional task of an institution effectively by means of optimum utilisation of all available resources (people and means). This emerges clearly in what Everard and Morris (1990: 4) refer to as what management is about: setting direction, aims and objectives; planning progress; organising available resources; controlling the process; and setting and improving organisational standards.

The scope of educational management, therefore, embraces all the activities that take place in the education system and specifically an educational institution. These are referred to as tasks by some authors (Van Der Westhuizen 1991: 52; Badenhorst 1995: 9-37; Kimbrough & Nunnery 1983: 42-78) or management areas such as external relations management, curriculum management, resources management, personnel management, and institutional development management (Strydom & Bitzer 1987: 18-20). These areas, functions or tasks, though distinct, are not separable; they are not disconnected but related, not hierarchical but interwoven (Van Niekerk 1988: 3,6). They are all embedded in the mission of the organisation or the institution, its reason for existence. At the system level it is referred to as macro management having to do with the wider spectrum of the management of the system usually at the national level. At the institution level it is referred to as micro management which is specific to the institution also referred to as the operational level (Van Wyk 1994: 4, 5).

### **2.3.2 History of Educational Management**

As already mentioned in 2.2, the field of educational management only became established as a scientific field after 1945 and initially developed following the Scientific Management approach of Frederick Taylor (Hersey & Blanchard 1982: 84;

Lawler 1986: 5-7; Bottery 1995: 25) emphasising tasks and treating workers as cogs in a system with little or no regard at all for their human needs (Van Niekerk 1988: 12). Subsequent developments took somewhat different trends in different countries with Africa lagging behind as G. F. Lungu in (Van Der Westhuizen 1991: 113) noticed. There was a general neglect of educational management training in Africa as of 1986. Recently, however, there have been several attempts in Africa, like elsewhere in the world, to introduce courses in educational management and administration in various institutions in Africa arising from the need to train administrators or managers for educational institutions. Various educational administration associations such as the Kenya Education Staff Institute (KESI), Management Training for Education Personnel Institute (MANTEP) in Tanzania, Standard Control Unit in the Ministry of Education in Zimbabwe (Mbamba 1992: 4) were formed and other similar endeavours in Uganda, Namibia and South Africa were initiated. These organisations are charged with the responsibility of providing management training for educational personnel in their respective countries.

### **2.3.3 Tasks of Educational Management**

Different authors have outlined the tasks of educational management or administration to include, according to Badenhorst (1995: 9-38), policy formulation, organising, decision-making, planning, communication, and control.

Campbell *et al.* (1983: 6-8) refer to six functions of administration which they discuss as: influencing the development of goals, stimulating and directing the development of the programs, establishing and coordinating the organisation to implement the programs, procuring and managing the resources needed to support the organisation and its programs, representing the organisation to local and larger communities and where necessary mediating among these groups, and appraising the effectiveness and efficiency of these operations.

Kimbrough and Nunnery (1983: 42-49) refer to a W. K. Kellogg-sponsored study of task areas of educational administration which include instruction and curriculum development, pupil personnel, community-school leadership, staff personnel, school plant, school transportation, organisation and structure, and school finance and business management. The study describes in more detail the functions of educational administration discussing, under structure, the main tasks as: a need for goal focus and structure in organisations, options in structuring organisations to achieve goals, a structure for decision-making, a structure for planning, a structure for initiating and maintaining communication, a structure for relating with local, state, and federal agencies, and a structure for citizen participation in planning and decision-making (Kimbrough & Nunnery 1983: 44-49). These are similar to what Van Niekerk (1988: 5, 6) refers to as the functions or activities of management in general.

As already mentioned, educational management tasks can be subdivided into sub-tasks. Sanyal *et al.* (1996: 14) also refers to the following main functions of management, planning, organising, leading, controlling and developing; each of which involves a number of sub-tasks (Castetter 1981: 14 & 57).

A summary of these sub-tasks or functions, as elucidated by Badenhorst (1995: 9-38), is given as the following major tasks:

- policy making;
- planning;
- decision making;
- organising;
- controlling.

The rest of the tasks, with exception of policy making, are beyond the scope of this study. Policy making should include articulation of the mission statement which,

according to McDonough and Noonan (1994: 13), is a basis for and direct instrument of policy formulation and analysis. Goals and objectives of an institution are discussed in detail.

#### **2.3.4 Policy Formulation in Educational Management**

Policy formulation or policy making is one of the main functions of educational management as well as other organisations. In some organisations like government or political parties, policy is also referred to as a manifesto referring to the perception it has in relation to a particular function of the organisation. According to Davies (1985: 139), one of the most critical tasks a senior academic administrator has to perform is policy formation. It is unavoidable by top university managers.

Policy formation includes formulation of a mission statement, goals and objectives (Van Der Westhuizen 1991: 144, 150) to the extent that sometimes these terms are used interchangeably. They are, however, distinct but related terms. Policy should be regarded as general statements or guidelines for decision-making to guide those who are involved in the implementation or execution of planning, and may be described as the purpose for which an undertaking is established (Badenhorst (1995: 10). Policy, according to Badenhorst (1995: 10):

- gives direction to the management of an organisation;
- is usually summarised concisely;
- is a guide for action;
- can be directed at the short or long term;
- can either be of overall nature or it can involve a subordinate part of the organisation.

The mission statement, goals and objectives emanate from the policy. The mission

specifically describes the task of the organisation. The mission is then broken into generalised broader focus, the goals which are further operationalised to more short-term measurable objectives (Van Niekerk 1988: 28 & Van Der Westhuizen 1991: 144, 145).

The policy making process should be guided by the following questions which identify whether the policy is workable, (Davies 1985: 161-162):

- Is the policy legally/constitutionally sound, and has it been delivered through appropriate channels to give it legitimacy?
- Is the policy politically acceptable and legitimate so that sufficient relevant interest groups will comply with the policy, implement it and not try to subvert or undo it?
- Have bargains/incentives been created to help interest groups to go along with the policy?
- Is the policy sufficiently explicit to enable it to be implemented by the executive administrators?
- Does it contain guidelines which are, however, not so rigid as to limit executive updating and creativity?
- Does the policy effectively provide answers to the problem which motivate policy formation in the first instance? Does it create more problems (spin-offs) than it solves (in terms of administrative complexity, financial hidden costs, frustrations for staff etc)?

A process that takes cognisance of these key issues is bound to come out with a sound policy. At the outset, however, according to Davies (1985: 140), the policy formulator needs to have an acute sense of organisational behaviour and culture and the laws according to which policy may change.

Universities are described as difficult and complex to manage and somewhat difficult to formulate and implement policies for (Davies 1985: 140). Their personnel tend to act differently in their different parts and respond differently. Organisational behaviour tends to be identified by six metaphors on a continuing basis. These are according to Davies (1985: 140):

- consensus decision making;
- anarchic processes;
- collective bargaining;
- administrative responsibility and accountability;
- democratic processes and respect of votes; and
- traditional authority.

This emphasises the need for careful consideration of the policy making process and for an awareness of the important questions referred to earlier. This would lead to a policy which is enforceable since a policy would not have much use if it cannot be enforced.

However, while policy should be enforceable, it should on the other hand be adaptable and flexible to prevent it from becoming obsolete but to instead be in harmony with the sociocultural, economic and educational realities (Rogus 1990: 8; Schwerin 1980: 175). If it is inflexible, it puts a damper on initiative (Van Der Westhuizen 1991: 152, Van Niekerk 1988: 37). It should be revised and adaptable to changing goals.

Policy making is a dynamic and changing management task which has to be adapted to changing circumstances not only in the educational situation but also, for example, in the social, political and economic environment (Van Der Westhuizen 1991: 151; Stott & Walker 1992: 51). This statement suggests involvement of stakeholders in the process of policy making who would provide the necessary information on these different facets of an organisation. McDonough and Noonan (1994: 10) suggest a four process strategy for designing a mission statement or policy. These are the:

- consultative process;
- interpretation process;



- formulation process;
- implementation process.

The consultative process, according to McDonough and Noonan (1994: 10), involves soliciting information from parents, students, community groups and individuals, and from staff members on the educational goals, policies and practice. They advocate the naturalistic inquiry as the best in yielding authentic results.

This is then followed by the interpretation process which involves the interpretation of the information collected searching for consensus (McDonough & Noonan 1994: 11). They emphasised interpretation rather than analysis.

The third strategy is the formation process in which a representative committee is established to draft the policy which is to be reviewed by the same stakeholders who were consulted in the first step.

The fourth and last step is the implementation process which according to McDonough and Noonan (1994: 13) includes wide dissemination of the policy to all stakeholders for a systematic, long-term implementation by encouraging all to become familiar with the statement.

According to McDonough and Noonan (1994: 13), from this process strategy the following lessons were learnt: the need to incorporate the views of the constituent groups, the importance of systematic collection of information, and that the statement is more than a mere statement.

Therefore, policy formulation in educational management is a process which should be flexible and adaptable. As circumstances change the policy should be reviewed to find out if it still suits the changing circumstances otherwise it becomes obsolete.

Additionally, for it to be successful, accepted and influence organisational behaviour positively, stakeholders should be involved during the process. In the case of educational management the stakeholders could include administrators, staff members, students, parents, community members and, at times, potential donors. It is important, however, to identify the primary or main stakeholders who must be involved in the process without the risk of narrowing the process too much as to be considered the privileged few who are involved. The process approach is preferred in which the final statement does not come as a result of a rushed approach but where time is taken to scrutinise each stage and yet not taking too long as to allow the organisation get used to a system without direction. This situation may be hard to change.

The idea of management is important for all types and levels of education including pre-primary education which Hoberg (1997: 37) says is as complex as any other type of education. This study, however, focusses on private tertiary religious education. The following sections are, therefore, devoted to these institutions beginning with a more general review of private education.

## **2.4 PRIVATE EDUCATION**

Most authors on education have written very little or nothing about private education. Private education may be regarded as education that takes place in private institutions. These institutions are referred to by different names in different places. Commonly used is the term private schools, colleges, or universities. They are also referred to as independent schools and universities although they are seldom fully independent in any country. Other terms used include non-government schools or institutions, *Harambee* schools, in case of secondary schools in Kenya, and grammar schools in Britain. Such institutions are generally defined as those institutions that are not financially aided in full or in part by the state (Kibuuka 1987: 1). They indeed, in

most cases, do not offer different education from that provided by the state aided institutions. Instead they are usually an alternative to providing education financed by a source other than the state (Berkhout 1993: 112-114) as far as state governments are concerned and constitute alternative provision of educational opportunities as far as the general populace is concerned (Saint 1992: 42). In some cases, however, there seems to be more in common between private and public institutions than there are differences (Grobman 1980: 200).

Private education has gone through different stages of development in the different countries. In some countries it has been the sole responsibility of the government to provide for all the education needs of the citizens while in others private education has had a longer history. The next section discusses the historical development of private education with special emphasis to the region under investigation.

#### **2.4.1 History of Private Education**

The history of private education and the reasons for the establishment of private institutions vary from country to country. Some of the reasons are inadequate vacancies and/or dropping standards in public institutions, economic reasons, political opposition, and religious proselytism. Despite these mitigating factors, according to T. O. Eisemon (in Saint 1992: 42), the development of private higher education in Africa has been severely constrained by difficult economic conditions, by the association of public universities with high quality education and access to modern sector employment, and by residual feelings from colonial experience that private involvement exacerbates inequalities in education.

The history and development of private education in most countries has, therefore, not been easy sailing. Private education has faced tremendous criticism in different countries despite its advantages which include according to Maphosa (1996: 8):

- increasing the provision of education and expanding enrolment at no extra public cost;
- responding more flexibly to market demands for specialist skill and diversity of programs;
- complementing government efforts to achieve the overall objectives for education.

Negative criticism in relation to private universities, according to Blair (1994: 11) included points such as:

- greater variation in quality than public universities, although according to Dekker and Lemmer (1993: 114) they are viewed as essentially élitist;
- the tendency to concentrate in narrow areas (often accounting and business);
- often related to churches and having a narrow focus;
- seen as expensive but second rate with inferior facilities.

It is noteworthy that its relation to churches is cited here as a weakness in the private education movement.

Cooper and Gargan (1996: 157) contend that the survival of private and religious institutions in the United States up to this time is a miracle. They have been faced with many adversaries. Referring mainly to secondary schools, they cite what may be termed as a metamorphosis of adversarial conditions. They are criticised that they sanctioned the isolation of students in homogeneous groups thereby not only abandoning the common acculturation of students but also fostering a tendency among the students to think of others as outsiders which constitute an invitation to prejudice (Cooper & Gargan 1996: 158). Moreover, they faced the current head-on competition through emulation by public education of privatisation (Cooper & Gargan 1996: 172). Private universities and other tertiary institutions have also faced

similar adversarial conditions and criticism in their development as already pointed out by Blair (1994: 11). They have been labelled as sectarian and of poor academic quality. Most recently, after being authorised to operate in some countries the public institutions, apparently because of either economic reasons or competition, have established similar programmes as the new private universities as well attempting to privatise some of their programmes and services.

Private institutions of all levels, notwithstanding, have continued to develop in most countries including those under study and in many cases have grown in numbers, diversity and quality.

Cooper and Gargan (1996: 173-176) also point out four issues which remain unresolved in the USA. concerning private education which also, to some extent apply to other parts of the world. These are:

- Unclear boundaries between "private" and "public" particularly when private institutions not only receive public funding but claim a right to it. This raises a question as to how independent and conscience-centred they can remain. Besides this there are more commonalities uniting private and public institutions than differences (Grobman 1980: 200).
- The relation between religiosity and education indicating that there is more to being a religious institution than prayer.
- Expansion of private education to the extent that a number of parents do not think that their children are safe from the influences of secular humanism.
- Values which have, in the past, led parents to commitment to support private and particularly religious institutions.

Despite the criticisms against and opposition to private institutions including universities, they have survived and continue to grow in numbers. In some countries

this development is seen as providing an alternative to the already over stretched public demands for education. Most of these institutions are affiliated to religious bodies although some have been accused of proselytisation. Some may have been established for the purpose of religious propagation. Many private institutions face lack of support because of what is perceived as acquiescence to public standards.

In the region under study there appears to be mixed reaction to the development of private education especially with regard to higher education. Some feel it is a desirable development that ought to be supported while some argue that the development may lower the standards of education (Williams 1989: 29, 56).

Under such circumstances the development of private education ought to be well planned and managed at both macro and micro levels in order to gain credibility. The next section discusses management and control of private education.

#### **2.4.2 Management and Control of Private Education**

Despite the definition of private institutions as independent schools, they are regulated and controlled by the governments in as far as standards are concerned although, to some extent, the principals of such institutions have more autonomy in the hiring and firing of teachers such as in the United States of America (Cooper & Gargan 1996: 169). Autonomy in recruitment of teachers has in turn assisted in the raising of academic standards. In South Africa, private institutions are required to comply with certain conditions which include, according to Dekker and Lemmer (1993: 230), contributing to the provision of education in an area where there must be a felt need; offering an approved curriculum; complying with the conditions about the composition of the students; complying with the minimum teaching requirements; complying with specific requirements for buildings; and submitting prescribed reports at the fixed times. Similar conditions exist in the countries under study and in relation

to private tertiary institutions although they may not be as precisely stated as they are in South Africa.

In Zimbabwe conditions for establishing private universities are outlined in the National Council for Higher Education Act of 1990 (Government of Zimbabwe 1990: 422-423) and include submitting the name of the university; objectives of the university; its membership and governance; its administration; finances; appointment, removal and conditions of service of members of staff; and admission rights and discipline of the students. These are provisions which are spelled out in the charters of private universities and colleges.

In Uganda, where no act of parliament regulating the establishment of private universities had been promulgated at the beginning of the study, the basic requirements were contained in a letter by the Permanent Secretary dated July 24, 1995 (Opika Opoka 1995: 1-2). They included the mission, aim and objectives of the institution and its code of ethics; name, location, proprietorship and governance; source of funding; regulations, recruitment procedures and conditions of service; initial academic and administrative staff; curriculum, courses, duration of study, awards and accreditation; enrolment capacity and planned projections; physical facilities and other learning resources; and comparative inventory and development plan. Towards the end of the study draft government acts had been prepared ready for presentation to the cabinet and the parliament. They included the same requirements in more details. They are discussed later in this thesis.

In Kenya, similar requirements are contained in rule four (4) of the Universities (establishment of universities, standardisation, accreditation and supervision) rules of the Commission for Higher Education (Commission for Higher Education 1990: ii, iii). They include the procedure for submitting the proposal for authority to establish a university; the name, location and academic character of the university; the aims and

objects consistent with the needs of university education in Kenya; the form of governance; outline of academic programs; the academic resources (including finances, staff, library, and equipment); and a timetable indicating the steps expected to be taken within three years of establishment.

Whereas by definition private education and private institutions are independent, in practice the independence may be said to be only in terms of financing but not so much in management and control. They are not free from government control for the sake of safeguarding the standards of education. In order to do this, therefore, without encroaching on the institutions' private condition the governments have attempted to come up with statutory organs to oversee the operation of these institutions as mentioned in this section for the three countries under study.

These organs of the governments are responsible for management of all private education. However, an important segment of private education is that which is operated and managed by religious bodies. Although many of the aspects already discussed apply to religious institutions as well, literature related to this class of private education, which is the subject of the current study, is discussed in the following sections.

## **2.5 RELIGIOUS PRIVATE EDUCATION**

As can be inferred from the foregoing discussion, many private institutions, including universities were associated to religious organisations. In the USA statistics indicate that 80% of the 24 types of non-government schools are oriented or affiliated with some religious institution or group (Cooper & Gargan 1996: 164). Cooper and Gargan (1996: 164) avow that one of the keys to private-school adaptation and survival has been the devoted support of religious groups and faith communities that operate these schools. They also quote economist Estelle James as explaining that,



universally religious groups are the major founders of non-profit service institutions (universities included). Usually these are proselytising religions which result into other religious groups starting their own institutions as a defensive reaction (Cooper & Gargan 1996: 164-165). This same situation applies to other parts of the world where, on the average, private institutions are affiliated to religious bodies. In Zimbabwe, for example the two chartered private universities are church-related.

Both the history of private education as well as education in general has a common history in that much of both was basically religiously founded. A discussion of the history of religious education and education generally in the next section may highlight some insights on this phenomenon.

### **2.5.1 History of Religious Private Education**

The history of religious private education has been quite similar to that of private education in many respects. This is because most of private education (over 80% in some countries) has been religious education. Holmes (1989: 9) contends that American higher education was a child of religion, citing Harvard, Yale, Princeton, and Columbia universities as having begun that way. The trend in the countries under study has been very similar, although the phenomenon of private universities in many parts of Africa is new. As universities continued to develop, by the 19th century many of them had lost losing their church connections and replaced them with financial support from secular sources and alumni contributions. Some of them became purely secular institutions (Stockey 1983: 12). At approximately the same time university education was introduced to Africa with that taint of secularism. After independence they aligned themselves with the development goals of governments which controlled the universities.

Like private institutions in general, religious universities have faced similar

adversarial conditions, most of which were because they were perceived to be basically religious institutions. In the United States it was legislated, for example, that religious instruction should not take place on school campuses (Kimbrough & Nunnery 1983: 88). This was in fear of indoctrination and proselytising which was believed to interfere with the individual's freedom. In South Africa, as a predominantly Christian nation yet multi-religious, religion may be taught in schools but each student is allowed the choice of and respect for their home religion (Dekker & Lemmer 1993: 237). This shows the diversity of approaches to handling religion in education mainly because it is thought to be a power that could be abused (Dekker & Lemmer 1993: 423).

Despite the legislation and adversarial circumstances, founded on the belief that religiously neutral education is impossible (Cooper & Gargan 1996: 174), and that a person is at heart (using the term heart in the biblical sense to mean the inner being) religious (Holmes 1989: 16), churches and other religious bodies have succeeded in establishing educational institutions including universities. The debate has, however, continued on the subject of separation of state and religion in several countries and the level of control exercised over these institutions by the state governments. The question of macro management of private religious education operating a dual system of government and religious control is a key issue. This is discussed in the next section and is one of the objectives of this study.

### **2.5.2 Management and Control of Religious Private Education**

One of the distinguishing features of religiously affiliated institutions according to De Jong (1992: 20) has been its private and independent character together with a self-perpetuating board and freedom from governmental control. However, as already

indicated, control of religious private education is a subject of much debate. Private religious educational institutions would desire to be autonomous while at the same time craving rightfully government grants to which they may be entitled as tax-paying citizens of their countries. On the other hand, governments would prefer to regulate and control all education in their jurisdiction even in such countries like the United States of America which advocates strongly for the rights and freedoms of the individual. This is particularly so in relation to higher or tertiary education. In some of the African countries it is postulated that the desire to control education particularly on the higher levels is, first of all, for political reasons and due to the apprehension that students may develop divergent views and ideologies which may create unstable situations for the government of the day. Secondly, it is due to the need to guard the standards of education from deteriorating as a result of unhealthy competition or inferior facilities. This has been true in some cases such as in Thailand, Indonesia, and the Philippines where according to Sanyal *et al.* (1996: 45) such expansion has often been at the expense of quality.

In the end there is a considerable amount of control of private religious education usually in the form of parliamentary acts, procedures for recognition or chartering, or ministerial proclamations. Two countries under investigation have promulgated official regulations with powers vested in a Commission for Higher Education in Kenya, and the National Council for Higher Education in Zimbabwe to regulate the establishment of private institutions. Uganda has yet to pass an official law. However, the Ministry of Education has produced guidelines and entrusted the powers in the Minister to see that these guidelines are fulfilled before a private institution is established and to guide its continual evaluation. National Council for Higher Education and University Acts have been drafted but had not yet been debated and approved by the cabinet and the parliament at the time of the study.

According to Furst (1992: 103), in the United States of America, some parochial

schools have cooperated with the state's effort to control them, while others have resisted every contact with government officials. Government officials on the other hand have been quick to declare themselves innocent of any desire to limit the operation of evangelical colleges (Winter 1987: 250). That may be possible in the United States America but not as easy so in other countries particularly in Africa.

Control by the churches or religious bodies though diminishing in some cases, has remained mainly due to commitment and devotion to the church or the religious body by those in the management of these institutions and to a lesser extent due to the financial support the institutions receive from the churches and religious bodies. The latter has been cited as the major reason for the diminishing control where the church coffers have dwindled in some cases or where there is already lively competition for limited church funding (Lewis 1984: 24).

The situation even becomes more complicated with regard to private tertiary education. Although the management of private education in general has faced problems, the issue of private tertiary education appears even more complicated as most countries depend on this sector for their supply of personnel as well as politicians. As a result they try to safeguard this sector more closely as it may also lead to the emergence of political adversary as well as the propagation of different ideologies. Management of private tertiary education is discussed in the next section.

### **2.5.3 Management of Tertiary Religious Private Education**

Management of tertiary or higher education generally is a complex issue as already indicated in section 2.4.1. This is particularly true of private religious education in the countries under study because the phenomenon is new. It may be considered as being chaotic not only at national levels but also at institutional levels. Chaotic not in the sense of being anarchic but in the sense which T. J. Cartwright (in Wheatley 1994:

123) refers to as "order without predictability". In the various departments of governments responsible for managing the affairs of private religious institutions policies are still being developed and yet there are already such institutions in operation. The complexity is further enhanced by the previous autonomy granted to religious institutions such as seminaries.

The chaotic situation is less eminent, however, at the institutional level where generally the management structure has been established except in very few cases. They are, however, affected by the complexity at the macro level since at times they are not certain as to how to relate to various offices of government. This is particularly so in those countries where parliamentary legislation has not been or has just recently been promulgated, such as in Uganda.

As alluded to elsewhere the reaction has ranged from succumbing to government control to dire resistance to such control. It may be time for a transformation from the notion that has been held by managers that organisations were unmanageable and characterised by rigid chains of command, protocols, and rules because they are afraid of disorder (Wheatley 1994: 3, 16, 17). Instead managers should regard them as self-organising systems with resiliency as their distinguishing feature rather than stability (Wheatley 1994: 88).

As a result of the different historical backgrounds of the different countries under study, they differ in the way education is managed for the public schools as well as the private ones, and for the different levels of education. The next section discusses management of education in the different countries beginning with a historical background and moving to the specific management of private tertiary education.

## **2.6 EDUCATIONAL MANAGEMENT IN KENYA, UGANDA AND ZIMBABWE**

Generally educational management rests, according to Van Der Westhuizen (1991: 30) and Bottery (1995: 12, 14, on several perspectives factors and philosophies which may differ for different countries. These same perspectives influence ideologies and management structures or governance of different nations. These perspectives are also referred to as external factors that influence business organisations (Van Niekerk 1988: 19). It is, therefore, apparent that structures of educational management in the different countries also differ from one to another. Van Schalkwyk (1989: 4-11) identifies the following demands and forces which contribute to particularisation of education systems:

- demographic and geographic factors;
- historical background;
- social-cultural situation;
- the political system;
- the economic system; and
- religious attitudes.

It is noteworthy that religious attitudes are included in this list. These are important factors and they differ from country to country. For example Van Schalkwyk (1989: 4) discussing demographic and geographic factors, describes northern Kenya as a semi-desert whose people are mainly nomadic and thus would benefit best from a nomadic type of school than a conventional school. Thus, the Government of Kenya has built boarding schools, even at primary level, so that children can continue to attend school even when their parents move with their herds (Eshiwani 1993: 47). The other factors also have common and diverse effects on education systems often affecting entire national systems and sometimes parts of the systems.

Each of the countries under study, therefore, demonstrated a certain uniqueness in their management although, having had a more or less similar political development and being similar in a few other respects, they have some similarities in their systems of educational management. The following discussion of each countries' system of educational management will include a brief discussion of their historical background.

### **2.6.1 Educational Management in Kenya**

Prior to 1911 education management in Kenya was in the hands of missionaries who, according to Eshiwani (1993: 15), made no attempt to link African education to African problems and the African cultural heritage. Instead, the period preceding 1911 was marred by a scramble among the many missionary bodies for supreme influence in different areas of Kenya (Eshiwani 1993: 16). At about the same time the Africans began to value western education but for different reasons than those intended by their educators whose major aim was originally to produce African priests (Eshiwani 1993: 15). Africans realised that education could offer them an avenue of escape from poverty and to socially advancement (Eshiwani 1993: 16). In 1911 a department of education was created by the colonial administration with the responsibility for education. Africans, however, continued to react against the then colonial education system because of its stratification structure into European, Asian, and African education in that order of superiority. Consequently, in order to benefit from formal education, they established independent schools which were for Africans and run by Africans (Eshiwani 1993: 17).

After independence in 1964 the Kenyan government under the ruling party, the Kenya African National Union (KANU) made education one of its priorities and compiled a number of important documents on education policy before 1968 when the Education Act was published. The Act put the responsibility for education in the hands of the

minister of education and instituted various organs for the organisation and management of education at all levels (Eshiwani 1993: 18,19).

Since independence the *Harambee* (self-help) spirit has played an important role in the development of education in the country resulting in what is commonly referred to as *Harambee* schools (Eshiwani 1993: 22).

Of the three countries included in this study, Kenya has been the most stable having had no major wars since it attained independence in 1964. As such, there has been a tremendous expansion in educational enrolment and facilities. "This resulted from a deliberate policy on the part of the Government both to ensure that access to education is seen as an essential basic need and also to meet the manpower needs of the economy" (Republic of Kenya 1989: 213). It also arose from the private demand for education because most Kenyans believe that higher education increases their chances for higher paying employment.

Education in Kenya is considered as one of the most important influences on the quality of life (Republic of Kenya 1989: 20). The government has therefore committed itself to the provision of equal education opportunities at all levels. This, according to the 1989-93 Development plan (Republic of Kenya 1989: 20), was reflected in the government's expenditure on the education sector which rose from 10% in 1964/65 to 20% in 1985/86 and to 35% in 1987 (Republic of Kenya 1989: 213) of the government is recurrent budget, although this has remained inadequate. As a result of this inadequacy the government introduced cost-sharing in 1988, a programme in which the beneficiary of the education services who are the students are expected to contribute by paying for a portion of their educational expenses (Republic of Kenya 1996: 136).

The guiding philosophy of education in Kenya is that "...the education system should



aim at producing individuals who are properly socialised and possess the necessary knowledge, skills, attitudes and values to enable them to participate in nation building" (Republic of Kenya 1989: 210, 211). It is further guided by the premise that "...every Kenyan has the inalienable right, no matter what his or her socio-economic status, to basic education" (Republic of Kenya 1996: 133). The philosophy is based on the following key principles, (Republic of Kenya (1989: 211):

- It is essential to make the public aware of the importance of conservation and enhancement of the environment in carrying out their activities.
- The education system should provide skills and appropriate technology for effective development of agriculture, livestock, forestry, minerals for both large and small-scale industries and foster attitudes for self-employment in both the rural and urban areas.
- Members of the public and the youth in particular should be educated in the most economical way of utilising agricultural land while at the same time protecting the environment.
- The development of positive attitudes towards environmental health both in the rural and urban areas must be encouraged.
- The promotion and appreciation of the national culture in its various dimensions must be seen as a prerequisite for meaningful national development.
- An appreciation of the need for population control and good family life for all communities must be developed in order to facilitate the fulfilment of basic needs and to foster human happiness.
- Full understanding of the concept and practice of the *Harambee* (self-help) Spirit and the *Nyayo* (the philosophy which states that the new president would walk in the political footsteps of the first president of the country after independence) philosophy in so far as they help the mobilisation of resources for national development at community level is the foundation of our development and must be actively fostered.
- All Kenyans must develop a sense of nationalism, patriotism, self-reliance and self-determination, the pillars upon which our national

pride and dignity are built.

Based on these philosophical principles, according to the 1989-1993 Development Plan, the education system is directed to finding ways and means to (Republic of Kenya 1989: 212):

- Assist the school leaver at every cycle to find gainful employment in the modern wage sector, small-scale enterprises and other forms of self-employment;
- make the individual more easily trainable at higher levels of education and training;
- instil realistic attitudes and aspirations regarding employment in both the parents and school leavers; and
- provide education as a human right as far as possible, and allow for both public and private participation in meeting the costs of achieving this objective.

Despite the stability in the government and its commendable achievements, the country has faced several problems primarily relating to declines in enrolment and completion rates, financing and relevance of education (Republic of Kenya 1996: 134). As regards enrolment and financing tertiary, or specifically, university education has been acutely affected because of the levels of funding which university education entails. As a result, as early as 1984, the second report on higher education in Kenya, chaired by J. G. Kiano recommended the formation of a Council for Higher Education as a matter of urgency to coordinate and harmonise the quality and standards of education in tertiary institutions (Republic of Kenya 1984: 72,73). Its functions were originally meant to include accreditation of universities, financing of university

education and research activities, overall planning, staff development, student enrolment, scholarships, university and post-secondary curricula, and harmonising the examinations and certification of post-secondary institutions (Republic of Kenya 1984: 72). This council later became the Commission for Higher Education whose responsibilities are to (Commission for Higher Education 1990: ii, iii):

- accredit universities;
- examine and approve proposals for courses of study and course regulations submitted to it by private universities;
- receive and consider applications from persons seeking to establish private universities in Kenya and to make recommendations therein to the Minister;
- ensure the maintenance of standards for courses of study and examinations in universities;
- advise the government on the standardisation, recognition and equation of degrees, diplomas and certificates conferred or awarded by foreign and local universities.

This then, through its organs and subcommittees, became the controlling body of university and tertiary education in Kenya. Earlier attempts to move in this direction was a 1947 government plan which established a Technical and Commercial Institute in 1954 by act of the Eastern Africa High Commission (Deloitte & Touche Management Consultants 1994: 6). It, however, did not go farther than that at that time.

Further legislation dealing with education was passed during the 1980's due to the increase in demand for higher education and the need for highly qualified manpower. These included the University Act of 1985 which established the Commission for Higher Education (CHE) responsible, as seen already, for accrediting and co-ordinating universities and their long term planning, staff development, scholarship

and physical development (Eshiwani 1993: 19). Kenya therefore became the first country in the region to take that direction.

During the same period, in accordance with the principles of providing education for its citizens, in 1985 Kenya moved from the 7-4-2-3 structure of education consisting of 7 years primary, 4 years ordinary level secondary, 2 years advanced level secondary and 3 years university; and introduced the 8-4-4 structure comprising of 8 years of primary education, 4 years of secondary and 4 years of tertiary (college/university). This placed strain on education particularly as far as tertiary and specifically university education was concerned which hitherto had depended on the country's only university, the University of Nairobi and its constituent college, Kenyatta University College (Eshiwani 1993: 68). The pressure placed on these institutions after the change of the structure led to the establishment of another public university, Moi University in 1984 and the subsequent establishment and chartering of private universities "in an effort to cash in on this thirst for university education" (Eshiwani 1993: 72). By the time this study began the country had six public universities, three accredited (chartered) private universities, nine non-accredited private universities, and 18 proposed private universities most of which are seminaries offering religious studies and theology at degree level and established by churches and church organisations.

Administration of education has been undergoing changes since independence, commencing with a Ministry of Education responsible for education in 1968. In 1979 the Ministry of Education was split into two Ministries one for Basic and the other for Higher Education. In 1983 the two Ministries were once again merged into a single Ministry of Education, Science and Technology (Eshiwani 1993: 96; appendix A1).

The Ministry of Education is headed by a minister, assisted by two assistant ministers with a permanent secretary who is the administrative head of the ministry and top

advisor to the minister on policy matters (Eshiwani 1993: 97).

The structure *per se* and the organisational chart does not reveal much about private tertiary education nor does the Education Act which only has a section on the registration of unaided schools in part IV dealing with primary and secondary school levels only (Government of Kenya 1980: 10). Provisions for the establishment, registration and accreditation of private universities are contained in the Universities Act (Government of Kenya 1989: 90-120; Kamunge 1988: 72). The Act also does not provide for the management of the universities which is left to the individual university charters which provide for management of the individual institutions. This in turn leaves their management at national level and the relationship of these institutions lacking although the Presidential Working Party on Education and Manpower Training stressed that the establishment of private universities should be carefully controlled and guided to ensure proper development and maintenance of acceptable university standards of teaching and research (Kamunge 1988: 71). This was despite the important role these play in the provision of education and training according to Kamunge (1988: 110).

Management of education in Kenya, therefore has gone through a number of stages since the time when it was primarily in the hands of the missionaries with a desire to produce priests to the current state when the country is interested in educating as many of its citizens as possible. As a result of the current desire Kenya became the first country among the countries under study to recognise and charter private universities in the year 1991. This move has provided an example to a number of the country's neighbours to allow the operation of private tertiary religious institutions especially degree granting ones. A neighbouring country learning from the example is Uganda. The next section presents the management of education in Uganda.

## **2.6.2 Educational Management in Uganda**

The history of education in Uganda very much parallels the country's political history. The country has gone through a period of political turmoil since attainment of independence in 1962. There has been a number of governments including a military one from 1970 to 1979, a period when not only educational services were affected but also almost every other aspect of life.

Although at independence national goals and principles of education were outlined as like in many African countries and enshrined in the constitution of the government, there was general lack of public awareness of these goals and principles according to the report of the Educational Policy Review Commission (Ministry of Education 1989: 16). The successive development programs and recovery programs were also not well-known. Nevertheless, the following goals and principles emerge from these national policy documents (Ministry of Education 1989: 16-18):

- Forging National Unity and Harmony;
- Evolving Democratic Institutions and Practices in all Sections of Life;
- Guaranteeing Fundamental Human Rights including Personal Security and Property Rights and the Rule of Law for all Citizens;
- Creating National Wealth Needed to Enhance Better Quality of Life and Self-Reliance;
- Upholding and Maintaining National Independence and Patriotic Feeling;
- Promoting Moral and Ethical Values in the Citizens; and
- Promoting a Feeling of Humanitarianism and Cooperation in the Citizens.

Management of education in Uganda was, therefore, expected to foster these goals and principles but in reality there were doubts as to the effectiveness of the system. In view of this it was decided, in 1987, to appoint an education policy review

commission with one of its goals being to recommend measures which would improve the management of schools and tertiary institutions so as to maximise cost-effectiveness, and to assess, among others, the role of the private sector in the provision of education at all levels (Ministry of Education 1989: 171-172). Although the commission produced its report in 1989, its full implementation had not been achieved by the time of this study. Parts of the report, however, including certain recommendations have been tentatively implemented pending the final approval of the whole report by the parliament.

Previously, until about 1964, the control, management and administration of education in Uganda was largely in the hands of missionaries and other voluntary agencies. During the years that followed, however, there were many changes that took place in the management of education in Uganda. The government assumed more responsibility through the ministry of education headed by a Minister who was a political appointee under whom were technocrats operating under the Permanent Secretary who was a civil servant. This was the official structure, although at times Deputy Ministers or Ministers of State for Education were appointed by the government to assist the Minister. There was a great degree of conservatism in administration of education, with concentration of all powers at the headquarters of the Ministry of Education and most decisions being taken at the headquarters (Ministry of Education 1989: 125). Additional changes, including those involving ministerial posts continued to take place. The Vice Chancellor of Makerere University, which hitherto had been the only national public university, and indeed the only university, was at the level of the Minister of State along with the Chairman of the Teaching Service Commission. Below the Permanent Secretary were heads of various departments such as the Secretary of the Uganda National Examinations Board, the Chief Education Officer, the Chief Inspector of Schools, and Principals of other tertiary institutions (see Appendix A2). It is apparent from this structure that there was little provision for private education with exception of an Assistant

Education Officer below the Chief Education Officer responsible mainly for private primary and secondary schools. There was almost no provision at all for private tertiary institutions (appendices A2 and A3).

The policy review commission of 1987, realising this and the important role the private sector can play in providing education even at tertiary levels, proposed the introduction of a National Council for Higher Education along with other structural adjustments which would undertake the development of programmes of higher education, plan the funding of universities and colleges and coordinate the admission of students while ensuring that the institutions are maintaining uniform and high standards (Ministry of Education 1989: 73-74, 141; appendix A3). It is, however, evident also from this report that little mention is made of private tertiary institutions even in the functions of the National Council for Higher Education. Similar to the old structure, private institutions are to be the responsibility of a Department of Private Schools which should have responsibility over all private institutions, including pre-primary schools, and is to help maintain certain minimum standards and provide the assistance needed for their healthy growth (Ministry of Education 1989: 138). The commission was, however, not in favour of government grants being extended to private schools (Ministry of Education, 1989: 155).

Management was to be further decentralised to district levels. However, prior to the commission's recommendations the regions and the districts had done little in the management of education. Regions did not even correspond to any other government (political) administrative structure. They also lacked infrastructure and resources. The new proposed structure included devolution of powers to the local authorities entailing assigning some decision-making powers to the local levels and the abolition of the Regional Education Offices (Ministry of Education 1989: 146).

In both the old and the new systems management at institutional level of tertiary



institutions is scarcely mentioned in the structure of education except indicating the position, in the hierarchy, of the Vice Chancellor of Makerere University (the national university). This leaves much to be desired as far as the development of private tertiary institutions is concerned and their relationship to and management by the Ministry of Education.

Management of education in Uganda has also gone through stages of development similar to those in Kenya. Unlike, however, the situation in Kenya where a law was already in place for governing private tertiary institutions, in Uganda, by the time of the study, the law had not been passed by parliament. Despite the lack of legislation there were already a number of universities operating by authority of licences from the government and some without. Without a law, management of universities was not yet uniform, both at national as well as at institutional levels, despite the move to permit the opening of private universities.

The move to allow private tertiary institution to operate which began in Kenya as indicated in section 2.6.1 may have had some influence in some countries other than the immediate neighbours. One such country is Zimbabwe which is another with an apparently overt policy on the operation of private tertiary institutions. The next section discusses literature on management of education in Zimbabwe.

### **2.6.3 Educational Management in Zimbabwe**

According to Atkinson (1974: 334-340) the development of education policy in Southern Rhodesia, now Zimbabwe, prior to 1974, appears to have passed through four main chronological phases.

The first one which covers the years of European settlement at the end of the nineteenth century up to 1923, is called the period of self-governing. During this

period officials of the British Southern Africa, which included present the Malawi, Zambia and Zimbabwe, were largely preoccupied with the need to achieve a satisfactory balance between the educational responsibilities of the church and the state. Much of the education provided during that period was by missionaries.

The second phase extending from 1923 up to the Second World War was a period of far reaching decisions concerning the future form of educational institutions in the territory. African education was based on efforts to raise the living standards of rural communities as a matter of priority (Atkinson 1974: 335).

No less significant developments took place at the same time in European, Asian and Coloured education, as the Southern Rhodesian schools system moved from a situation of close dependence on educational institutions in South Africa, to an increasingly intimate relationship with educational practice in the United Kingdom (Atkinson 1974: 335). The emphasis was on quality at a time when virtually all other African countries were still emphasising quantity (Atkinson 1974: 336).

This tradition of emphasising quality as remained up to the present as in Zimbabwe there are relatively fewer educational institutions than in the other countries under study and the procedures for establishing them are stringent. In order to maintain the high standards the government scrutinises and examines many things in a relatively thorough procedure before authority is granted to open an institution.

From the outbreak of the Second World War (1939) up to 1963, the year when the Central African Federation was dissolved marked the third phase. During this phase there was increasing pressure from the outside world mainly due to the growth of science and technology which carried implications for schools in Southern Rhodesia at all levels. During this period there were two major developments:

- The first institutions for African education were established under missionary direction.
- The first university was established in 1955, which was the first major experiment in integrated educational facilities for Africans and non-Africans (Atkinson 1974: 242).

The main reasons for the establishment of the university were:

- attempts by local people to found a university institution during the previous decade, and
- the program of university institutions in the British Colonial Empire based on the recommendations of the 1945 Asquith Commission (Atkinson 1974: 338).

This development, according to Atkinson (1974: 242) was a logical sequence to the large scale expansion in secondary school facilities for more than a decade, resulting in increasing demand for specialist degree courses to produce teachers for advanced level subjects.

Following the demise of the Federation from 1963 to 1974, the time Atkinson carried out his study, marked the fourth phase which included a series of far reaching political changes. Most noticeable of these was the outbreak of militant African nationals during 1961 and 1962, the dissolution of the Federation in 1963 and the process of estrangement of Rhodesian front rulers from the imperial authorities in London (Atkinson 1974: 339). This had some effect on Rhodesian education particularly in the form of assistance from abroad.

A step towards a more co-ordinated and effective system of educational administration came during 1964, not without opposition from the Rhodesian front political authorities (Atkinson 1974: 340). This was the end of the Federation when it

became necessary to unite both African and European, Asian and Coloured Administrators under the same Ministry of Education. Despite the opposition by the Rhodesian front political authority, the new organisation did, at least, provide an effective basis for cooperation between teachers and administrators at every level (Atkinson 1974: 340).

Due to caution about granting university status prematurely which seemed likely to do harm in the long term, (Atkinson 1974: 244) the process of establishing a university went through a number of commissions starting with the Asquith Commission which recommended, among others, autonomy of university education (Asquith 1945: 34). The Cartmel - Robinson Commission made a second report to the Central African Council, which emphasised the urgency of higher education facilities (Cartmel - Robinson 1951: 3,9,10). The British Government's recognition of this urgency was signified by the establishment of a Commission under the chairmanship of Alexander Carr - Saunders in September 1952 (Atkinson 1974: 247). This Commission also recommended the university as an autonomous corporation with accountability to the public (Carr - Saunders 1953: 28).

Following the dissolution of the Federation of Rhodesia and Nyasaland at the close of 1963 there were serious questions raised, the most serious one concerned the University College's multi - racial character (Atkinson 1974: 260). This and the period that followed was characterised by Rhodesian Europeans' concern about the security of their interests. The two other countries that made up the federation established their own universities, the University of Malawi in 1964 and the University of Zambia in 1965. The Rhodesian Prime Minister announced what was referred to as Unilateral Declaration of Independence (UDI) in November 1965, a move that had further far reaching implications for the university college (Atkinson 1974: 262). Major implications were:

- a threat to the sources of funding from abroad, and
- increased contention with political controversy among Rhodesian's population.

The culmination of these movements was the University College's breaking of its relationship with the University of London in 1970 with exception of the Medical School which maintained its relationship with University of Birmingham for the students who were already registered with it (Atkinson 1974: 273). In May 1970, the then autonomous university of Rhodesia was provided, with a university council. One third of its membership was nominated by the Rhodesian Government, one third by a variety of public and professional bodies, and another third by the academic staff in line with the recommendation of the Carr - Saunders Commission (Carr - Saunders 1953: 28) of the principle of nomination opposed to representation representing outside bodies (Atkinson 1974: 275).

The period between 1970 and 1980 was characterised by a heightened struggle for independence which included wars within the country. In those areas which were not affected by the war and were able to continue operating, there were many new developments as far as education was concerned. One university continued to operate and a number of students studied outside the country. In the year 1980 Zimbabwe attained independence and this was followed by a number of changes .

The Government's first Development Plan after independence for the period 1986-1990 had six primary objectives (Williams 1989: 2):

1. to correct the imbalance and control of the economy and economic expansion;
2. to bring about land reform and efficient utilisation of land;
3. to raise the standards of living of the entire population, particularly the peasant population;

4. to enlarge employment opportunities and manpower development;
5. to develop science and technology;
6. to maintain a balance between the environment and development.

One of the major considerations in implementing this Development Plan was the need to train additional high-level manpower (Williams 1989: 2).

Following the tradition of commissions, the independent Government of Zimbabwe in 1988 set up a commission to investigate the need for expansion of university education provision in the country with particular emphasis on the establishment of a second university. This was mainly because manpower requirements had risen sharply and the number of applicants to the then only university had also risen resulting in the raising of entrance requirements making it very difficult for qualifying students to enter the university (Williams 1989: vii, 2). As with the previous commission, one of the major concerns of the commission was the balance between quantity and quality, that is, "...the necessary expansion should not be at the expense of quality" (Williams 1989: 29). With this in mind the commission advocated the creation of a National Commission of Higher Education as a parallel body with the secretariat at the Ministry of Higher Education to coordinate and harmonise the different forms of tertiary education provisions in the country (Williams 1989: iii). The commission observed that it should be the responsibility of the national government to manage and control tertiary education because of the following reasons, (Williams 1989: 56):

- it reflects the importance of universities and colleges as institutions at the apex of the national education system that give intellectual training as well as helping to define the culture and identity of the nation;
- these institutions are crucial in the development of high level skills and in the generation of useful knowledge. This function can not be left to a series of accidental and uncoordinated decisions by private interests;

- government's involvement guarantees maintenance of standards and quality; and
- higher education is costly; therefore it has to be subsidised by government if it has to be accessible to more than a select few.

In this vein the commission recommended that non-government institutions serving primarily Zimbabwean students should be affiliated to the national universities in Zimbabwe or accredited to a validating body within the nation (Williams 1989: 61, 103).

The commission also recommended the establishment of a second autonomous university in Bulawayo to start in 1993 with a science and technology bias (Williams 1989: 104). This was established in 1991, with its first intake on April 8, 1991. Two private universities have also been established and chartered. These are part of the subject of the current study. They are, however, not affiliated to the national universities as recommended by the commission. In addition, in accordance with the commission's recommendation, a National Council for Higher Education was established.

The National Council for Higher Education (Government of Zimbabwe 1990: 416), operating as part of the Ministry of Higher education, is responsible for:

- ensuring maintenance of appropriate standards with regard to teaching, courses of instruction, examinations and academic qualifications in institutions of higher education;
- receiving and considering applications for the establishment of private universities and university colleges;
- establishing common student admission procedures for institutions of higher education;

- advising the Minister and the institutions concerned -
  - (i) on the establishment, maintenance and expansion of universities and university colleges,
  - (ii) on the co-ordination of training at institutions of higher education,
  - (iii) on the standardisation, recognition, and equation of degrees, diplomas, certificates and other academic qualifications conferred or awarded by institutions of higher education whether in Zimbabwe or elsewhere, and
  - (iv) generally on issues relating to higher education;
- arranging and conducting visitations and inspections of institutions of higher education; and
- making recommendations to the Minister on the disbursements of funds to institutions of higher education.

The Council outlines the procedure for establishing private universities and university colleges (Government of Zimbabwe 1990: 422) which includes, in summary, initial application to establish a private tertiary institution being submitted to the Council for Higher Education. The Council then makes its recommendations to the Minister of Higher Education, who in turn consults and makes recommendations to the President of Zimbabwe. Once the application has been accepted, it is proclaimed in the Government Gazette (Chivore 1995: 2).

The application referred to above is accompanied by a draft charter which makes provision for the following (Government of Zimbabwe 1990: 422, 423):

- the name of the university or university college;
- membership and governance of the university or university college;
- the administration of the university or university college;
- the finances of the university or university college;



- the appointment, removal and conditions of service of members of staff; and
- the admission, rights and discipline of the students.

Despite this development private education in Zimbabwe, according to Chivore (1995: 35) is as old as the introduction of formal education itself and was mainly done by missionaries who, however, tended to concentrate on teacher, secondary and primary education. Chivore (1995: 36) further contends that private tertiary education in Zimbabwe is there to stay because of the huge demand for tertiary education which cannot be satisfied by the existing public institutions. The two must complement each other.

On the national level, as far as general educational provision and management is concerned, the Education Act, 1979 (Government of Rhodesia 1979: 171) provides for the general management of education in the country including the establishment, maintenance, equipment and regulation of both government and private educational facilities and other services. These services are provided by what was formerly the Ministry of Education, as in the Education 1987 Act, which was divided into two ministries, namely: the Ministry of Higher Education and the Ministry of Education and Culture in 1988, (Ministry of Education and Culture 1988: 16). The Ministry of Higher Education is in charge of all higher institutions of learning such as the University, Teacher Education, the Polytechnics, and all Technical Colleges. The Ministry of Education and Culture on the other hand is responsible for all schools and colleges that provide pre-school, primary and secondary education. In addition it is also in charge of sections that provide educational services such as the Curriculum Development Unit and the Non-formal Section (Ministry of Education and Culture 1988: 16).

The Ministry of Higher Education is headed by a Minister. The next in the hierarchy is the Secretary who has three deputies (Appendix A4). These are responsible for

Institutions; Research, Evaluation, Policy and Planning; and the third one for Finance and Administration (Ministry of Education and Culture 1988: 17).

As in the case of Kenya and Uganda, however, no mention is made of universities both government and private in the Education Act and in the hierarchy of management. The partnership approach existed from the time the missionaries established educational institutions, although this partnership was dominated by the government (Siyakwazi (1995: 342) which made it a weak partnership instead of strengthening it. The desire for involvement was also emphasised by the Minister of Education when he said that “I do not see how the problem, which is so complex, can be solved by the government alone” (Mutumbuka 1989: 50).

Apparently, therefore, the omission of private tertiary education in the hierarchy of the Ministry of Education is probably because the National Council for Higher Education takes care of this level of education. The University of Zimbabwe operated under its Act (Williams 1989: 92). The proposed second national university (which began to operate in 1991) was likewise to be governed by its Act as a full-fledged university enjoying such autonomy as provided under its Act (Williams 1989: 93). The National Council for Higher Education, however, is under the umbrella of the Ministry of Higher Education as shown on the organisational chart in appendix A4.

In order to understand management of education in Zimbabwe the historical background of education in the country was provided. This explains the reasons for the different approaches to management of education in general. Management and organisation of private tertiary education in Zimbabwe is still in the infancy stages as are the institutions themselves. This is despite the role played by missionaries in the establishment of education in the country. Private education will apparently remain to thrive even at tertiary level because of the demand for education which leads many to continue to seek education outside the country which is usually more expensive than

most can afford.

#### **2.6.4 Summary of Educational Management in Kenya, Uganda and Zimbabwe**

The history and management of education in the three countries in this study have a similar background to a large extent although there are few differences between them relating to the time when they became independent and the major objectives they are pursuing for education. It is noteworthy that management of universities in all countries is not included in the education Acts but rather provided for in the university charters of the public universities and the newly established Commission for Higher Education in Kenya and National Council for Higher education in Zimbabwe. Uganda at the beginning of the study had not yet established a body of that nature although it is provided for in the White Paper on Education. The contribution of the missionaries and religious bodies both at the inception of education as well as during the current development is also remarkable. Most of the private tertiary institution are religiously affiliated. The institutions may therefore, be referred to as operating a dual system of management. They have management that hinges on their founding religious bodies as well as state management Operating in such a system requires clarity of mission and objectives on the part of those involved in management in order to provide direction to the institutions. The ensuing sections discuss literature related to vision, mission and mission statement and their role in management of tertiary private education.

### **2.7 VISION, MISSION AND MISSION STATEMENT**

The terms vision, mission and mission statement are very often used interchangeably although they are intrinsically different. The following is a discussion of these terms as used in literature. Since not much literature is available on these subjects within the population territory, much of the literature reviewed was from outside the territory of

study.

Thelin (1986: 103), cites Gordon Davies as arguing that contemporary academic institutions do stand for clarity of purposes of mission although they are usually not clear. Raising a number of interesting questions about missions, G. K. Davies (in Thelin 1986: 107) suggested that further research ought to be carried out as to why not all such institutions have succumbed to the non-clarity of purpose. The same notion is explicit in the statement made by Cochran and David (1986: 108) citing Steiner's observation that components of mission statements are least understood and recommending further research to improve management's understanding of these important planning documents. It is further evident that research on the subject is necessary due to the apparent confusion implied in the various definitions of the terms vision, mission and mission statement. Nevertheless despite the variation in the explanations of these terms and vagueness in their articulation, they remain vital planning documents for organisations (Detomasi 1995: 31; Pearce 1982: 15; Harvey 1994: 51). Vision, although not as commonly used as mission, is apparently implied when reference is made to visionary leadership as part of good management which includes strategic management. Vision therefore, is the subject of the discussion in the next section.

### **2.7.1 Vision**

According to Lewis (1989: 42), vision is an individual's image of the future based on a combination of information, knowledge, ideas, aspirations, dreams, threats and opportunities. It articulates a view of a realistic, credible, attractive future for the organisation (Bennis & Nanus 1985: 89). Bennis and Nanus (1985: 89) further contend that it is the leader's responsibility to develop this image before he or she chooses the future direction for the organisation.

According to Peters and Austin (1985: 286), vision must start with a single individual. This does not mean that team effort of refining and review, which is critical in establishing a unique identity for the school and strengthening the bonds of loyalty among members of the institution (Wilson & Cochoran 1988: 77), should be ignored. It only stresses the importance of the role the chief executive of the institution plays. He or she should have the raw materials for the effective vision and share it with the stakeholders (Peters & Austin 1985: 286). This, according to Knott (1995: 128) requires training and guidance for the chief executive who should be able to develop and implement a vision.

Bennis and Nanus (1985: 97-101), notwithstanding that vision is supposed to be future oriented, contend that the past and present help in guiding the development of a vision. They suggest that as far as the past and present are concerned the following provide useful insights for mission development (Bennis & Nanus 1985: 97,98). The past provides:

- the principal's (or chief executive's) own experience;
- the experience of other educators particularly in similar positions;
- the history of the school or institution;
- members of the local community;

and the present:

- provides a first approximation of the human, organisational and material resources for the formation of the future;
- provides insight into the current staff, students and parents' potential for development and expansion of the services offered to them by the institution;
- provides trends regarding values and needs of the population and the politicians;

- can be used to test the opinions of staff and pupils.

Synthesis of this information acts as the test for the chief executive's management in providing the institution with a visionary direction. The information implies that the development of a vision does not only focus on the future but is augmented by the past and present. It also implies that the manager or chief executive plays a very important role both in terms of his/her own experiences as well as in the actual establishment of the vision. Others in the organisation and in the community and the resulting vision provide a number of insights into the different potentials available in the organisation as well as in the community and the trends regarding values and needs of the population. In doing this the following characteristics are essential and should be given due consideration in managerial decision-making, (Bennis & Nanus 1985: 102-103):

- foresight to be able to judge how the vision will direct the institution;
- hindsight, so that the vision is in line with the traditions and culture of the community;
- a world view within which the new development and changes are interpreted;
- in-depth appreciation in order to be able to see the whole picture appropriately;
- peripheral vision, to be able to take into account and understand the vision of and responses of other institutions and stakeholders;
- a process of revision of the vision as the environment changes;
- considering the appropriateness of the time;
- giving due regard to the simplicity and complexity of the image;
- taking into account the extent of continuity with the past as against radical transformations; and
- being cognisant of the degree of optimism and pessimism the vision contains, its realism and credibility and its potential impact on the institution as a whole.

According to Knott (1995: 131), for visions to be effective they must result in action. Knott (1995: 131) suggests the following sequence for realising the vision of a school:

### 2.1 Knott's Sequence of Realising Vision (Knott 1995: 131)

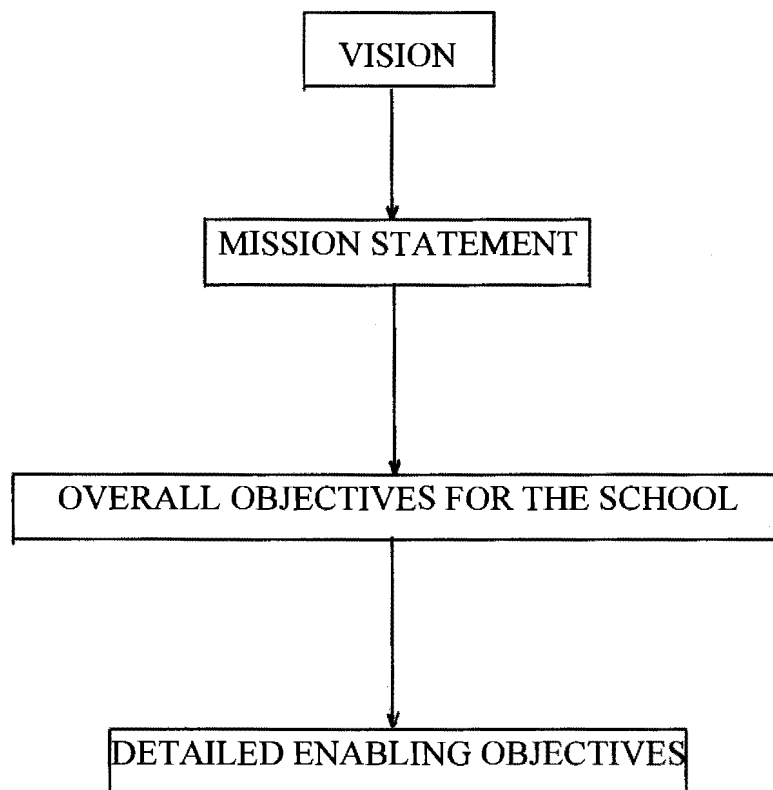

According to the sequence, vision leads to mission statement although often these two are used synonymously.

Vision, therefore, may be regarded as the starting point of designing a mission statement which in turn is a key to all planning. Although it is habitually defined in terms of the future, the present and past help in its formation. Its commencement with the individual does not limit it to that individual. It only stresses the importance of the chief executive in being visionary to view the future of an organisation. This vision

ought to be shared with others in the organisation if it is to guide the entire organisation in its functions. The chief executive should be knowledgeable of the organisation's past and its environment and should guide prompt decision-making without making it too complex, relating future objectives to past experiences for continuity.

The translation of the mental image into action plans constitutes what may be referred to as strategic planning. This includes developing a mission for the organisation encapsulated in the mission statement, and then proceeds on to goals and objectives according to Knott's sequence (Knott 1995: 131), vision being the starting point. In the next section, literature related to mission and mission statement is discussed.

### **2.7.2 Mission and Mission Statement**

Mission statement or statement of purpose refers to the mission or purpose of an institution (Lang & Lopers-Sweetman 1991: 600). It defines the central *raison d'etre* (purpose for existence) of an institution (Campbell & Yeung 1990: iii). According to Lang and Lopers-Sweetman (1991: 599- 600), there are typically two views of the institutional mission or purpose statement. The first one is a caricature referring to it as the foundation on which the house of intellect stands. The second one is a defence of such statements as representing assumptions and purposes that guide the planning as well as the activities of an institution.

Accordingly, Lang and Lopers-Sweetman (1991: 613-615) cite a study by Lang in which, with comparatively few exceptions, mission statements could be empirically organised into a few generic classifications as follows:

- The historical-philosophical statements, concentrate on what the institution is and how it came to be that way;



- The action plan type, which are mission statements which describe the ways and means of planning and purposes. They address both goals (ends) and objectives (means);
- The interrogative or optional statements, which are heavily oriented toward process placing great emphasis on consultation. They often state that the institution will be committed to excellence, and then ask how excellence should be measured;
- Those which are expressions of scale and capacity, found in highly organised and centralised systems of post-secondary education. They focus on enrollment and physical requirements differentiating among institutions to the extent of demanding certain levels of enrollment in certain programs;
- The messianic tablets, which are the types that are closely identified with the president of the institution, and expressed in personal terms. They are usually highly personalised and depend on the persuasive and political strength of the president. Such mission statements are not easily transferrable to a new administration;
- The anthologies of mission type, which are in effect compilations of plans of the various units within a university, usually found in large heterogeneous institutions where consensus is difficult to achieve.

Other authors refer to mission statement as focus and purpose of the school (Herman 1989: 79); the basic purpose of an organisation, that is, what it is trying to accomplish (Kotler & Murphy 1981: 478); the institution's educational philosophy or a long-term standard by which the institution may continually evaluate its policies, programs, and performance (McKelvie 1986: 152); a broadly defined but enduring statement of purpose that distinguishes its business (or function) from other firms (or organisations) of its type and identifies the scope of its operations in product and market terms (Pearce 1982: 15); a statement of an organisation's vision of itself that serves to guide program planning, development, and evaluation (Rogus 1990: 7;

Torgerson 1991: 477); the organisation's statement of its purpose, intentions and priorities or its direction (Stott & Walker 1992: 50); an organisation's function in society reflected in the products and services it provides for its customers and clients (Harvey 1994: 51) and; a stable account of what type of institution it is or should be, usually stated in outline in the charter given by society to the university (Davies 1985: 80). While these definitions of mission statements all allude to purpose, their differences in emphases are usually reflected in the mission statements of different institutions. Their juxtaposition, however, accentuates the need for understanding the role of mission statement in management.

Outstanding ideas in these definitions include purpose of existence in society; philosophical justification for existence; influence on programs, policies, and priorities, services and functions; planning; product (or results); direction; customers or clients; development; evaluation and performance and; vision and values. These are concepts which the manager not only in the business world but also in the educational realm, is confronted with. Mission statement formulation is a function of management and is inextricably interwoven in the functions of a manager. It affects most of the tasks of an institution's manager.

Additionally, mission, according to Arth *et al.* (1987: vii), encapsulated in a mission statement is a powerful tool for school improvement and they define it as "...the shared vision of people in an organisation about what their ultimate purpose really is. In effective schools, they add, "...the vision is usually shared among the teachers, administrators, students and the community" (Arth *et al.* 1987: 2). Among the ideas that emanate from the above statement are a shared vision, an organisation, ultimate purpose, effectiveness, improvement, power, and tools. Each of these words or ideas apparently should have a bearing on the mission of a given organisation or institution.

Mission is also cited by Fowler (1994: 37) as what defines the institution's reason for

existence. Rasi (1994: 3) states that it helps to focus attention and rally the energies of an entire institution around its primary purpose. Rasi (1994: 3) suggests that the entire statement should fit on one page and that once it has been developed, it serves as a point of reference for everyone involved with the institution in activities such as granting admission, hiring staff, determining curriculum and co-curricular programmes, updating and applying the code of discipline, and generally strengthening the identity of the institution.

Campbell and Yeung (1990: 4-6) contend that besides mission statement defining the central business of an organisation it has to do with the culture, values and behaviour of the organisation. Taking this into account, they developed the Ashridge Model for assessing the identity of an institution in terms of its mission containing the following elements (Campbell & Yeung 1990: 6, 7):

- purpose, the reason for existence;
- strategy, which comprises the organisation's methods for achieving its purpose;
- behaviour standards, the norms and regulations of the organisation; and
- values, which are the beliefs and moral standards of behaviour standards.

These elements are linked together in a mutually reinforcing manner in the Ashridge Model as follows:

Figure 2.2 The Ashridge Mission model (Campbell & Yeung 1990: 6)

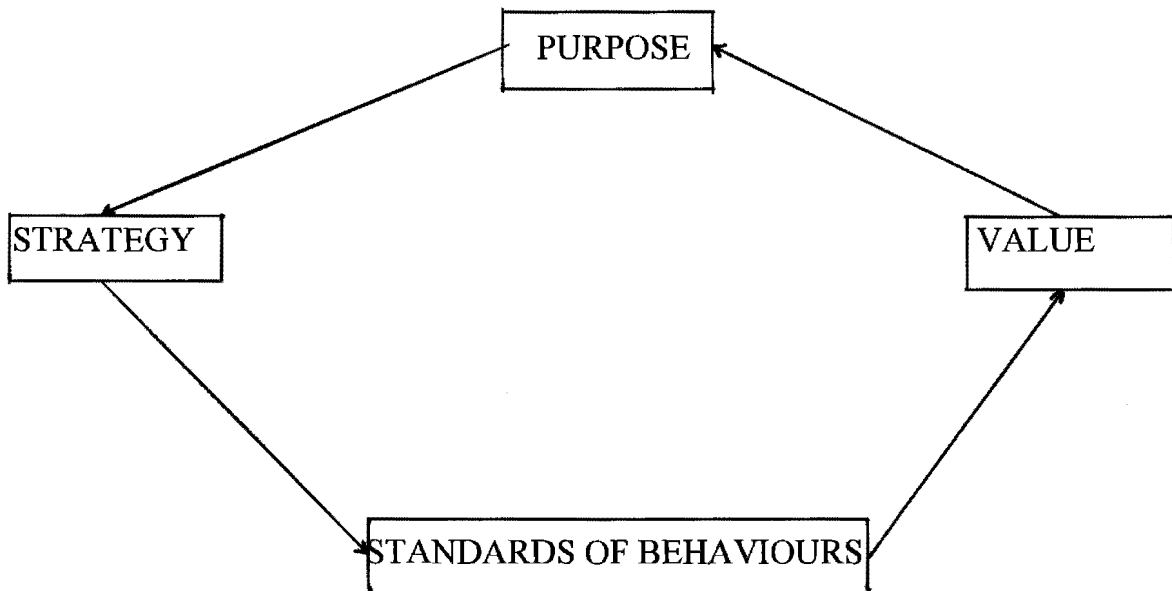

The model illustrates the intertwining nature of mission having to do with purpose, values, standards of behaviour and strategy.

Lewis (1989: 46-47) describes a mission of a school as theorising the operations of the school stated in such a way that it provides a sense of direction to everyone, states the population and services and/or products provided by the school and provides a basis for planning and evaluation. It mobilises the forces within a school in a concerted effort and a strong commitment to the vision provides guidance and direction. It should withstand change, thus facilitating identification of strengths, opportunities, weaknesses and threats, referred to as a SWOT analysis, in overall planning which is (or should) be a basis for allocating resources. It also provides the parameters for governance and management of the organisation.

In order to fulfil these requirements a mission is not something that is rushed nor does it represent the working of a single person. Even though the role of the chief executive as a visionary leader is a key factor in the development of a mission for an

institution, a functional statement of mission ought to be a product of a process. This is the subject of the next section's discussion.

#### *2.7.2.1 Mission Statement Formulation*

Rogus (1990: 7) suggests that the following questions have to be addressed as part of the process for identifying the school's (or an organisation's) major reason for being :

- What is unique about our organisation?
- Who are our principal clients?
- What are our primary services?
- What is different about us from three years ago?
- What will be different three years from now?
- What philosophical issues are important to the school's future?

Rogus (1990: 7) says these questions should be addressed during the planning process of an organisation or institution and as can be observed, they are fundamental in the formulation of a mission statement. They address the uniqueness of an organisation, refer to its clients and services and the organisation's present, past and future. They therefore emphasise connectedness and continuity.

Lang and Lopers-Sweetman (1991: 601) when discussing the importance of process in developing mission statements, contend that "outcome depends on process" since planning refers not only to the end product but to the activities that enable members of the institution to create their own picture of the organisation's place and future.

Detomasi (1995: 31) affirmed this stance when he stated that "mission statements are both product and process, and the latter is as important in advancing the objectives of planning as the former."

McDonough and Noonan (1994: 10) also confirming the importance of mission statement assert that there is little information on the process of development.

McDonough and Noonan (1994: 10) then propose four distinct processes (section 2.3.4):

1. a consultative process, which is more or less a data gathering process;
2. an interpretive process, mainly concerning searching for consensus;
3. a formative process, which is the drafting process; and
4. an implementation process which is the dissemination to all stakeholders and the use of the mission in the formulation of policies by personnel in the organisation.

Likewise, Saint (1992: 127) also contends that mission statement starts with a consultative process addressing three key questions: What kind of university does the country have? What kind of university does the country need? What kind of university can the country have? Although these questions differ from those posed by Rogus (1990: 7) and refer, by implication to public universities, they address similar key issues that need to be taken into account when formulating mission statements. They can also be applied to private universities affiliated to religious organisations although these too operate within given larger environs also referred to as publics.

A similar process to that proposed by McDonough and Noonan (1994: 10) is suggested by Herman (1989: 79) This includes: deciding the stakeholders; outlining an agenda or data gathering and; developing the vision by studying the trend of "what is" and "what should be".

Thus, there appears to be no single agreed upon process for formulating the mission statement of an institution. Despite this disparity (Matejka *et al.* 1993: 34) and the dearth of certainty (Thelin 1986: 106), several authors on the subject emphasise the

importance of the process. They contend that mission statement is both a product as well as process (Covey 1990: 129; Detomasi 1995: 31; Hagstrom & Steen 1995: 6). They also emphasise the need for participation and involvement of the stakeholders. This is implied in the process suggested by McDonough and Noonan (1994: 10-13) when reference is made to consultation and dissemination which imply participation. Hoverland *et al.* (1986: 39) suggest that successful strategic planning demands participation while Hayward (1986: 30) considers the community to be a very important source of information which is vital in mission formulation.

Detomasi (1995: 31) contends that arguments for participation are philosophical in that it is more fair for people who are affected by public decisions to be consulted. This kind of participation, he argues, brings fresh ideas and mitigates against narrow thinking and sectarian actions. Stott and Walker (1992: 51) and Herman (1989: 79) identify overall benefits of involvement such as clarity, ownership and support. Rogus (1990: 8) also supports the notion that involvement is the most effective approach to develop ownership of a mission statement.

Argent (in Harvey 1994: 53) argued that mission statements were outputs not inputs to the strategic planning process developed through careful, logical discussion. This underlines what Evans (1990: 10) cited as consensus rather than majority rule. McDonough and Noonan (1994: 37) refers to this as the basic guideline for the interpretive process.

Ishoy and Swan (1992: 11-15) provide a most practical guide to the process of developing a mission statement by suggesting the following steps:

1. brainstorming, that is having a session of asking and answering questions. This can be part of a SWOT analysis.
2. prioritising, deciding on what to be included and what to be left out, and in

which order of importance.

3. refining, a process of providing drafts and seeking feedback by management and other stakeholders.
4. implementing the mission statement and making it and its importance known to the institution.

The author would add a step to those proposed by Ishoy and Swan. That is re-evaluation since it is not until the implementation step that flaws in the process and the product can be identified requiring a re-evaluation and re-implementation.

The process suggested by Ishoy and Swan (1992: 11-15) ensures what Campbell and Yeung (1990: iv, 10) referred to as "sense of mission" which is essential if management is to succeed in establishing a participative management style. Campbell and Yeung (1990: 11,12) see this as very important function of management as the greater the link between school policy and individual values, the stronger the individual's sense of mission.

It may be concluded therefore that the process of mission statement formulation is as important as the product and that the product is more easily accepted if the stakeholders are involved in the process of formulation. Methods of formulation may differ from situation to situation but most authors concur with starting with consultation, and ending with evaluation after implementation to check on effectiveness. The process begins with asking questions about the organisations past, present and future as well as a SWOT analysis. The process of asking questions itself implies involvement. It should therefore, be what is referred to as a participative method involving all stakeholders.

One of the benefits of the participative process, which according to Garug'e and Berstecher (1984: 98) means the distribution of decision-making power in such a way



that all those affected by decisions should have a share in making them, is the feeling of ownership and the sense of mission among all involved. It also makes implementation easier. A further step in the process suggested by the author is that of evaluation. In order to check if the product of a process is the right one or the expected one there ought to be evaluation and further implementation as part of the process.

Having developed a mission statement, it has to be communicated to the members of the organisation as well as the public. This is done in the form of articulation which is the subject of the next discussion.

#### *2.7.2.2 Mission Statement Articulation*

The term articulation used here refers to using language easily and fluently in order to express with effectiveness and clarity. This has a bearing on the value of a mission statement in the management of an institution. The mission of an institution not clearly expressed to the stakeholders and the community may remain simply another statement which is not well known other than by the chief executive(s). It is also argued that many institutions' mission statements are vague. According to Hoverland *et al.* (1986: 33) the mission of higher education is generally amorphous and not easily quantifiable, yet clearly articulated mission statements have two advantages: they provide an organisational touchstone for defining organisational inputs and their ordering; and secondly, they provide a standard for gauging both individual and group efforts. They are usually contained in the institution's official documents such as the charter (Davies 1985: 86) and bulletins, the prospectus and handbooks. It is also the university president's (Vice Chancellor, Rector or Principal) responsibility to further articulate the mission statement in public speeches and other writings (Tierney 1988: 11). Although, according to Stott and Walker (1992: 50), there is still confusion about the way in which the mission should be articulated leading to generally

imprecise mission statements, literature seems to emphasise clarity of mission statements (Rogus 1990: 6; Peeke 1990: 5; McKelvie 1986: 151). In addition, researchers, according to Cochran and David (1986: 110) stress the need for the mission statement to be readable and written in a positive sense.

Although mission statement articulation is closely related to formulation, it was singled out in this study in order to emphasise its importance since many university statements of mission are vague and expressed in unclear language. It is, however, evident that institutional mission statements should be clear in order to perform the functions they are meant to perform in the management of institutions. It is also suggested that mission statement should be widely disseminated through various media to all those concerned who have an interest in the institution. The responsibility for this dissemination lies with the chief executive of the institution.

As a whole, a mission statement which is supposed to be articulated is made up of various parts which may be referred to as the components of the mission statement. There appears to be no agreement on the components, although as discussed in the following section, some key elements are pointed out by various authors on the subject of mission statement components. The next section therefore, presents the discussion of literature on the components of a mission statement.

### *2.7.2.3 Components of a Mission Statement*

Beside the elements proposed by Campbell and Yeung (1990: 7) referred to in section 2.7.2, there is little agreement on the components that constitute a mission statement. Pearce (1982: 16) suggests the following eight components of a mission statement:

1. target customers;
2. basic products or services;

3. primary markets;
4. principal technology;
5. concern for survival, growth, profitability;
6. company philosophy;
7. company self-concept; and
8. concern for public image.

This appears to be the most comprehensive synopsis of mission statement components in literature. Pearce (1982: 17), however, later summarises these components as the company's basic service, the primary market and the principal technology to be used. Arising from the eight components this omits the element of philosophy or philosophical basis which is basic in a mission statement of not only a company but of an educational institution as well. Other components left out in the summary such as self-concept, public image and survival could be incorporated into one element which is the general goals and objectives as proposed by Moseley (1980: 180), Klimoski (1991: 20) Davies (1985: 84-86) and McGinnis (1981: 41) in the following itemisation of mission components and characteristics:

- the identity, that is a description of the enterprise or college it aspires to be, or the definition of the college whether it is a liberal arts college, undergraduate or graduate college;
- global purpose, highlighting an organisation's service to society and its distinctiveness that distinguishes it from other colleges, limiting enough to exclude some ventures and broad enough to allow creative growth;
- audience which is the primary market;
- key strategies which may be similar to principal technology in Pearce's (1982: 17) list above;
- goals or desired outcomes also referred to as general goals and objectives and should serve as a framework for evaluating both current and prospective

activities;

- the basic commitment of the college based on its world view;
- the college's educational philosophy which is a practical expression of its commitment; and
- its statement in terms sufficiently clear to be widely understood throughout the organisation/institution.

The inclusion of goals and objectives as components of a mission statement often leads some to simply list the institution's objectives and goals as the institution's mission statement yet there should be a distinction between them. The mission is usually much broader and gives the reason for existence. The goals and objectives are often used synonymously but they too differ. Goals are general desired outcomes and objectives are often specific outcomes which are usually given in measurable or easily identifiable outcomes and behavioural changes.

According to Davies (1985: 85), analysis of mission statements of institutions which claim to have explicit missions, goals, aims and objectives yields a considerable level of generality encompassing a set of beliefs about the nature of the institution and an element of uniqueness. Therefore, despite the disparity on the components of mission statements, they are still of value in portraying the vision of management and directing the affairs of the institution. They form part of the organisational culture which is reflected in what is done, how it is done, and who is involved in doing it (Tierney 1988: 3). This is why the component of the institution's commitments and philosophical basis is an important one since culture is embedded in the philosophy of life and the world view.

Whereas there is disagreement on the components of a mission statement, there is some semblance of agreement on certain elements which ought to be included in an institutional mission statement which make it a motivating force for an institution.

These include the philosophy or basic beliefs of the institution, its identity, the customers, and methods it uses to serve the customers (Pearce 1982: 16,17; Mosely 1980: 180; Davies 1985: 85; and McGinnis 1981: 41). The philosophy or basic beliefs are sometimes referred to as the world view which shapes the activities of an individual or organisation in any circumstances. It is the basic belief that attempts to provide the answers to the questions such as “why are we here?” The same question shapes what a mission statement attempts to answer as well. The reasons why basic philosophy is important are therefore fundamental and provides the initial direction in a mission statement.

Having identified the basic beliefs the next issue in a mission statement is the identity of the institution or organisation. What is the organisation? It may be possible to have the same basic beliefs but different identities. Declaring the identity, although implied by basic beliefs, may refer to delineating the institution from other similar institutions. It implies mentioning what the institution is (Moore, 1986: 21) and defines the culture of an organisation (Seraphin, 1997: 11). Mouritsen (1986: 46) states that it is not a crime to say what one believes in because it is such boldness that gives identity and purpose to an institution, an *esprit de corps* that motivates and produces valuable approaches to problem solving. This may also refer to mentioning to whom it belongs.

After identifying of the institution the mission delineates the customers it serves. It is not possible for an institution to serve all people or categories of people. These may be people of similar basic beliefs. Mentioning the customers, therefore delineates the specific customers served by the institution, (Cochran & David 1986: 109; Harvey 1994: 52). It may also include delineating the primary geographical territory covered by the services of the institution.

The services provided by the institution are given in the mission statement by a general statement of the methods used to serve the customers, (Cochran & David

1986: 109; Davies 1985: 85; Harvey 1994: 52). Usually these services are given in details in the institution's statement of its objectives but it is argued that the mission statement should mention broadly the services provided and the general methods used.

Most mission statements would usually have the components mentioned above which may be elaborated but are difficult to condense without losing some vital elements of the statement or down-playing the mission statement's role in the operation of the institution and in its management. The next section discusses literature related to the mission statement's role in institutional management.

### **2.7.3 The Role of Mission Statements in Institutional Management**

As mission statements are statements that describe reason for existence, it would be inescapable for any institution to exist without one. Yet literature depicts an assortment of scenarios which does not exactly agree with the expected reality. On the other hand, Knott (1995: 138,139) argues that a mission must be pursued and managed. This implies that the mission of an institution does not come without effort on the part of the management of an institution.

Moreover, for an institutional mission to be of use in the management of an institution it ought to be simple and easy to translate into concrete terms. This has not been the case as depicted by Doucette *et al.* (1985: 189) who state that despite the interest, attempts to apply research findings to practical management have largely failed.

Doucette *et al.* (1985: 189) highlight the problem as the translation of the abstract goals (goals used here in a generic sense to include mission) provided in the research into concrete terms that can be incorporated into the management processes of the college or university.

Grobman (1980: 200), on the other hand, argues that by experience and rationalisation there is more in common uniting private and public institutions than there are differences. This explicates the problem of institutional missions not clearly revealing the uniqueness of an institution in practice. Consequently, the need to understand the role of the mission statement in institutional management becomes crucial in educational management.

Although these two authors do not indicate the value of mission statements in their observation of goals and mission in practice as would be expected, they do not negate the value of mission statement but instead emphasise the value of defining institutional mission in terms of activities in which the institutions engage as distinct from the philosophical background to which these activities relate (Doucette *et al.* 1985: 203). This activity-driven mission concept, offers a productive and interesting alternative to the hierarchical objectives/goals model which has dominated research on institutional mission (Doucette *et al.* 1985: 203).

Detontasi (1995: 31) also refers to university mission statements as embarrassingly vague, and largely comprised of academic pieties, dull platitudes, and odes of self-congratulation. However, Herman (1989: 82), McGinnis (1981: 39), McKelvie (1986: 155), Pearce (1982: 15), Van Niekerk (1988: 39), contend that developing a mission statement is a crucial step in the strategic planning process. McKelvie (1986: 155) further refers to strategic planning as outlining the institution's goals; the plans for achieving these goals and deployment of resources to attain these goals; or the opportunity for analysis, maximising the institution's opportunities in its environment through the positioning of resources. In this connection, talking about resources, Dressel (1987: 109) argues that once the mission goals and specific objectives are determined, the organisation and the characteristics of the individuals selected to provide specific services can be determined. Rogus (1990: 12) further suggests that the vision (mission) statement should constitute the basis for developing interview

questions to be addressed to prospective faculty members. Blending and Jones (1989: 23) suggest similarly that in a healthy organisational culture, the mission statement and guiding beliefs set the direction for planning and action, which is the same idea as strategic planning.

Klimoski (1991: 20) proposes his understanding of a mission statement as follows:

- it reflects a sense of the wider purpose toward which particular activities are directed;
- it serves as a measure for decisions to be made or actions taken;
- it provides a source of common identity;
- it creates a distinct identity for the organisation, group or institution;
- it establishes a base for continuity over time;
- it provides a bridge for a change or redirection of effort;

These roles, which are akin to the nature, components and the characteristics of a mission statement (section 2.7.2), are the responsibilities of management.

Management is responsible for directing the activities of the organisation, making important decisions, and establishing continuity as well as change where necessary.

Similarly, Davies (1985: 90-91) discusses the functions of a mission statement as an indication of the expectations external constituencies have for colleges and universities thus being at the interface between the institution and its environment.

Mission statement used by policy makers and planners is a sales and public relations tool and can be used to pummel state leaders (or proprietors) who may be reluctant to allocate the money the institution needs (Davies 1985: 91). State planners can also use the same mission statement to halt certain academic developments or to adjust funding based on performance measured against it.



Despite university mission statements as generally vague, mission statements play a role in the management of institutions as many of the responsibilities of management depend on clearly defined mission statement according to literature reviewed. They are important in tasks such as deployment of resources both material and personnel. Material resources would ordinarily be allocated to those tasks which are in line with the institution's mission statement. It was also argued that they may be used to solicit funding from proprietors as well as donors. Planners and policy makers doing strategic planning depend on a clear mission for the institutions for which planning is being done. Analysis of the plans and their evaluation is also done against the missions of the institution being evaluated and the programmes being analysed. Mission statements also ensure the continuity of institutional programmes even in the midst of changes which management may want to implement. Mission statements, therefore, play an important role in the management of institutions.

As a result of the role mission statements play in institutional management and the changing nature of the contemporary world, there occasionally arises a need for further development or examination of institutional mission statements to suit the prevailing circumstances. The next section discusses literature related to the need, conditions for development and review of mission statement in institutional management.

#### **2.7.4 The Conditions, Need for and Review of Mission Statement in Institutional Management**

Lang and Lopers-Sweetman (1991: 605) and Peeke (1990: 5) suggest the following conditions that could give rise to the development of a statement of institutional purpose:

- there may be new and different internal or external expectations of the

university's programs, services, and policies requiring an effective response to such changes;

- the evolution of academic disciplines may call into question the organisation of the curriculum and educational audit designed to highlight qualitative indicators of performance;
- new research initiatives that may create new opportunities and new requirements;
- federation or affiliation, or other changes in the governance and administration of a university may alter its profile and demand corresponding changes to its statement of purpose;
- budget pressures, funding changes, securing funding, enrolment growth, and change in the enrolment distribution; and
- the need to assess the quality of development.

Change in programmes, services and policies appears to be a very important condition for development of a mission statement. However, according to Parker (1986:177) in those organisations without a strong shared sense of mission the urge to "do something" may compel leaders to make more radical changes than would ordinarily be possible in a collegial governance structure. This may be the case with many higher educational institutions which are often referred to as organised anarchies (Campbell *et al.* 1983: 62).

Davies (1985: 80) accordingly argues that it is necessary to analyse managerial effectiveness in the context of university mission and purposes- the *raison d'etre* of the enterprise. Likewise Strydom (1988: 11) emphasises that a leader's first responsibility is to develop a vision for the institution and draw others into the vision by making it tangible to constituencies both inside and outside the university. Strydom (1988: 4) also noted that mission oriented leadership is strong leadership. Thus mission statement plays a vital role in institutional management.

Campbell and Yeung (1990: 20-22) suggest the following important conditions for and management of mission statements:

- Creating a mission statement is a long-term endeavour, this does not mean that an institution should operate for a long time without a mission statement. An interim statement taking into account the basic tenets can be formulated which is actually the one to be improved over the period;
- Sense of mission among the top management is crucial particularly as regards consensus on the values they are to communicate. Bottery (1995: 2) contends that "...there is a strong interaction between values and management," and that the choice of values will have important implications for the kind of management;
- Communication of consensus or mission is better done by actions than words;
- It is essential for the top team to be visible. They contend that "It is hard to believe in an organisation if you feel out of touch with the leadership" (Campbell & Yeung 1990: 21);
- Since leadership is a key to the creation of a mission, which takes time, it is important to have continuity of the top management;
- Strategy and values are (or are supposed to be) inseparable and should therefore be formulated together;
- Another important linkage is between behaviour and values. Management should focus on the link between behaviour and values since employees feel a sense of mission if they believe and act the way they believe;
- "Published statements are most useful when they document the existing mission of the organisation" (Campbell & Yeung 1990: 22). This further stresses the importance of action reflecting reality rather than intention which the public does not see.

From the literature discussed above it apparently is evident that the role of mission

statement in management and the conditions or needs for a mission statement are not distinctively different. Furthermore, the role of the mission statement in the management of tertiary institutions and specifically religious ones is no different from its role in general educational management. It only becomes specific to the kind of institution denoting its uniqueness from other institutions and its basic function in society (Harvey 1994: 52). The general historical mission of a university is threefold according to Strydom (1988: 3) and Streharsky (1991: 38), which is some times described as training, research and community or public service. However, the specific way in which an institution carries out this more or less universal mission is what is contained in its mission statement which should be unique for different institutions. It is also influenced by culture, which is referred to by Kotler and Murphy (1981: 486) as the shared way of looking at things, a notion that is shared by Blendinger and Jones (1989: 23) who refer to culture as a shared understanding people have about what is valued and how things are done in an organisation. Education cannot be isolated from culture (Saayman 1991: 30). Saayman (1991: 31), stressing the relationship between education and culture, refers to education as the systematic process through which a community provides moral and intellectual training in agreement with its heritage in order to develop (especially among its youth) mental and physical powers and character. He refers to culture, in this context, as the sum total of the non-biological inheritance of human beings. Davies (1985: 140) stresses the need among policy makers to consider culture when he stated that "...the policy formulator must have an acute sense of organisational behaviour and culture and the laws in which this may change."

Discussing the role of the university in their keynote address to the colloquium on university in Africa in Lesotho, Hagstrom and Steen (1995: 3) contended that the university of a country is part of the culture of that country, and Mouritsen (1986: 46) stated that where there is no culture there is anarchy. Furthermore, there is no value-free approach to education. It is usually rooted in some culture which may be based

on either political ideology or religion.

Religion is a part of culture in the sense that it comprises shared values and ways of looking at things. Religious institutions particularly universities realise that they operate in societies of diverse cultures and therefore attempt to design their missions taking into account this reality. According to De Jong (1992: 23-25), the mission of church-related (religious) institutions therefore includes declaring the source of meaning and ultimate value, commitment to the student's intellectual development but with a qualitative difference since all universities are committed to intellectual development of their students, shaping the lives of the students in ways other than intellectual growth but also social, physical, and spiritual development which is a holistic approach to education, and commitment to responsible citizenship including the teaching of ethics in curricular and co-curricular programs. This kind of mission would inevitably be expected to influence the management of the religious tertiary institution. Lewis (1984: 24) states that funding from church depends on leaders being convinced that the mission of the institution is being fulfilled, a notion that is shared by Yarrington (1981: 20) who stated that it is impossible to discuss financing without reference to the mission. All these are management tasks which determine support from the constituencies.

Moseley (1980: 181-182) provided the following five reasons why a church-related (religious) college (or university) should design a mission statement:

- to demonstrate the difference between the mission of the church and that of the institutions for they are ( or at least supposed to be) different missions;
- to help the institution to address the realities of higher education, to help it to attune to new conditions, work on internal problems and thus reduce the vulnerability to adverse publicity, and uphold its distinctiveness;
- to act as an important benchmark against which the institution can be

evaluated;

- to enable the institution to choose and select what to do and to make decisions;
- to canvass support from its constituencies.

It is therefore important for every institution to have a mission statement of its own designed to direct its services and functions. The mission statement, according to the literature, should be distinct enough to serve as a basis of the institution's evaluation in achieving its objectives. The process of designing the mission statement is generally agreed to be participatory involving the stakeholders.

## **2.8 SUMMARY**

In this chapter an array of relevant literature was reviewed with the intent of providing a general focus and the nature of available literature on the subject. It began from brief general review on the subject of management as a whole since this was not the subject of study, and then moved to specific areas pertinent to the study. Under the general review, however, it was observed that as a discipline of study, management is generally still new. Original studies were mainly in the areas of business. It was also noted that all management has to do with working through and with people to accomplish tasks and that it is the manager's responsibility to focus the attention of all those being managed on the tasks to be accomplished. This is a similarity between all kinds of management whether business or educational. However certain differences were referred to and these led to the different management specialities such as educational management.

Educational management, which was defined as the regulative tasks or actions by a person in a position of authority in order for formative education to take place, was also defined in terms of the different tasks performed by the manager. These were seen to include planning, executing the plans, evaluating the performance and re-

planning. This served as a summary of the many tasks specified by several authors on the subject of educational management. It was observed that the process which begins with planning initially starts with having a vision which is translated by the planning process into mission, goals, objectives and implementation. The process was also referred to, by some authors, as policy formulation although this connotation seems to leave out the implementation part of the plan. This process was observed to be more important particularly in the case of private tertiary education which is a rather new development in the region covered by the current study.

Private education was defined as that which does not receive regular grants from the government although at times may receive some support in the form of financial or material support. The governments are not obliged to provide financial support to these institutions although, being the custodians of education for their citizens, they are responsible for some control over the private schools. Although private education in the countries covered by the study is not generally a new phenomenon, the introduction of degree granting private autonomous institutions is a fairly new development and most of these are religiously founded. The authorities in the governments were, therefore, still in the process of developing or fine-tuning legislation for the control of private institutions yet without taking over the management of these institutions.

The different stages of development in this direction within the three selected countries were highlighted. Kenya was observed to have progressed furthest in establishing the body to regulate the development of private tertiary institutions followed by Zimbabwe which had established the body to regulate the development. Uganda was only formulating the policy in form of a parliamentary act but had not yet had it approved by the parliament.

The process of policy making to allow for and regulate the development of private

tertiary education had to do with the countries' different historical backgrounds which, although in some respects were similar, were different due to their political history. A synopsis of the historical background of the countries was presented. Since the development of private tertiary educational institutions was fairly new in the region little data was available within the region under study. Most of the available literature was from the USA. Moreover, church related literature which had a bearing on private tertiary education was also consulted.

Literature that relates to the concepts of vision, mission and mission statement was also reviewed and presented, beginning with the concept of vision which is supposed to be the starting point in designing a mission statement. Mission was defined as the reason for existence and was observed to be very important to institutions and management. A key function of management is to formulate a mission for an institution designated as a mission statement and that this is best done through a process involving all stakeholders in the organisation. This participation process was observed to have benefits such as a sense of mission among the stakeholders, ownership of the plans and their support. It further helps bring new ideas to management in the process and makes its articulation and dissemination easier. Reasons were identified why institutions, particularly church-related or religious institutions, should design their mission statement to include a demonstration of the difference between their mission and that of other institutions as well as addressing the realities of higher education which might be a new experience for them in the region. In this way the private institutions would justify their unique role in higher education.

Chapter three presents a literature review related to qualitative research methodology and then discusses the specific research design for this study.



## **CHAPTER 3      QUALITATIVE RESEARCH METHODOLOGY AND RESEARCH DESIGN**

### **3.1    INTRODUCTION**

In chapter two literature related to mission statement and management with emphasis on educational management and particularly private religious tertiary education was reviewed and discussed. Much of the available literature was authored from outside the region of study mainly because the phenomenon of private and particularly religious education is still relatively new in the region unlike in the United States of America where private religious tertiary education has been in existence for some time. Likewise not much literature has been authored in the region about mission and mission statement particularly in the area of education. Most of what is available has been authored in the area of business. Despite some differences in the business and educational approach to mission statement, there are many areas similarity.

In this chapter literature related to qualitative research methodology is discussed including a brief historical background, philosophical basis or traditions of qualitative research, techniques, ethical issues, trustworthiness and data analysis and presentation. The chapter then presents the research design for the present study. This includes rationale for the choice, researcher subjectivity, sample, data collection methods, data analysis, reliability and validity of the findings, ethical issues and trustworthiness.

### **3.2    QUALITATIVE RESEARCH METHODOLOGY**

Although qualitative research methodology has had a long history in studies of anthropology, philosophy, and sociology (Hasselkus 1995: 75), its use in education has only been acceptable in the last twenty to thirty years (Hopkin 1992: 133; Tierney

& Lincoln 1994: 107). Examples of qualitative research in higher education are not many (Whitt 1991: 406) due to a lack of understanding of the method, training and the notion that for research to be scientific it has to be positivistic. Much of the training in research hitherto has emphasised the "scientific" research methodology which has been positivistic quantitative research methodology. Literature related to qualitative research methodology is further evidence of this as it is almost exclusively authored in the 80's and 90's. Nevertheless, qualitative research methodology has developed to become acceptable in research in education with specific traditions.

The term tradition, according to Evelyn Jacob (in Gall *et al.* 1996: 592), refers to "...a group of scholars who agree among themselves on the nature of the universe they are examining, on legitimate questions and problems to study, and on legitimate techniques to seek solutions." This definition refers to researchers as well as theorists (Gall *et al.* 1996: 592). These traditions are not isolated but do interact with each other and are influenced by each other resulting in cross-fertilisation (Gall *et al.* 1996: 592). This at times results into transformations of traditions with time. Gall *et al.* (1996: 592) also contend that researchers within a given tradition may at times disagree on epistemological assumptions and other matters making it difficult to provide "an exhaustive list of and definitive description of research traditions."

Gall *et al.* (1996: 593), however, provide one of the most comprehensive lists of qualitative research traditions (see figure 3.1) classified into three main paradigms based on the type of phenomena to be investigated. These are: investigation of lived experience; investigation of society and culture; and investigation of language and communication. He, however, mentions that the list is not exhaustive as the field of qualitative research is undergoing rapid development (Gall *et al.* 1996: 594).

Figure 3.1 below displays a summary of the traditions according to Gall *et al.* (1996: 593)

Figure 3.1. Qualitative Research Tradition Classified by Type of Phenomena Investigated  
(Gall *et al.* 1996: 593)

---

<u>Research Tradition</u>	<u>Involves the study of</u>
<b>I. Investigation of Lived Experience</b>	
1. Cognitive psychology	Mental structures and processes used by individuals in different situations
2. Life history	Individual's life experiences from their perspective
3. Phenomenography	Individual's conceptualisation of reality
4. Phenomenology	Reality as it appears to individuals
<b>II. Investigation of Society and Culture</b>	
1. Cultural studies	Oppressive power relations in culture
2. Emancipatory action research	Practitioners' self-reflective efforts to improve the rationality and justice of their work
3. Ethnography	Characteristic features and patterns of culture
4. Ethnomethodology	The rules that underlie everyday social interactions
5. Event structure analysis	The logical structures of social events
6. Symbolic interaction	The influence of social interactions on social structures and individuals' self-identity
<b>III. Investigation of Language and Communication</b>	
1. Ethnographic content analysis	The content of documents in cultural perspective
2. Ethnography of Communication	How members of a cultural group use speech in their social life
3. Ethnoscience	A cultural semantic system
4. Hermeneutics	The process by which individuals arrive at the meaning of a text
5. Narrative analysis	Organised representation and explanation of human experience
6. Semiotics	Signs and meanings they convey
7. Structuralism	The systemic properties of language, text, and other phenomena

---

Most qualitative research problems can be investigated within one of these traditions although, as Gall *et al.* (1996: 592) have stated, there occurs a lot borrowing and cross-fertilisation. The present study is one of such cross-fertilisation between traditions borrowed mainly from ethnography, event structure analysis and ethnographic content analysis.

### **3.2.1 General Orientation**

The term qualitative research has no single universally agreed upon definition (Fidel 1993: 220). It at times is defined in terms of what the familiar, most common quantitative research is not, and often in terms of the different approaches utilised such as field-work, naturalistic inquiry, grounded theory and participant observation. It, however, has the following fundamental beliefs: that events must be studied in their natural settings; and that events cannot be understood unless one understands how they are perceived and interpreted by the people who participated in them (Tuckman 1994: 389). Qualitative methods permit site-based analysis that can uncover the unique overt and covert workings of a particular context (Crowley 1995: 57). Accordingly, Mackay and Schuh (1991: 424) and Tuckman (1994: 388) propose the following features of qualitative research:

- the natural setting as the data source and the researcher as the key data-collection instrument;
- it attempts primarily to describe and secondarily to analyse;
- the concern is with process, that is, with what has transpired as much as with the product or outcome;
- its data is analysed inductively as in putting together the parts of a jig-saw puzzle; and
- it is essentially concerned with what things mean, that is, the why as well as the what.

The features indicate a departure from the hitherto commonly used positivistic method which emphasises detachment from the phenomenon and the setting being studied in order not to influence or be influenced by it. The features also emphasise the inductive approach rather than the positivistic deductive approach. Process and not only the product is of essence. Furthermore Mackay and Schuh (1991: 425), Morse (1994: 43) and Wilson and Hutchinson (1991: 266) maintain that the goal of qualitative research is understanding and discovering meaning.

In so doing, Eisenhart and Howe (1992: 648) suggest that the following attributes: completeness, appropriateness, clarity, comprehensiveness, credibility and significance are important for a good study.

This presupposes a well organised methodological approach that would demonstrate these characteristics from data collection to analysis and reporting. Careful preparation prior to the study, thoroughness during the study and taking into account the relevancy of the study in terms of its credibility and significance which are the attributes of scientific research but not necessarily a positivistic study, are essential. The next section therefore, presents the discussion of literature related to data collection taking into account these attributes and presuppositions.

### **3.2.2 Data Gathering Methods**

Wolcott (1992: 6) suggests that like all research, qualitative research has dual facets joined in complementary opposition like the two sides of a coin. These are ideas that drive the work and inquiry procedures with which the researchers pursue them. Sometimes these two are pulled apart to the extent that they become almost separated, and sometimes they are recognised as forever joined and complementing each other. The philosophical basis of qualitative research methodologies is, therefore,

phenomenological interpretation and understanding also referred to by Steckler *et al.* (1992: 2) as the "insider's view." This is usually accomplished through a multi-method approach (McMillan & Schumacher 1993: 416-417).

The commonest data collection methods are observation, interviewing and document analysis (Anderson *et al.* 1994: 108; Tuckman 1994: 393). Morse (1994: 45) suggests attendance at meetings as another method which may be included in observation, Wolcott (1992: 19) identifies these methods in daily language as watching, which is observation; asking, which is interviewing; and reviewing, which is archival or document analysis. These are also akin to experiencing, inquiring, and examining respectively which are natural phenomena.

Of the three methods the most common is interviewing. It is also used in quantitative research (Ormla 1994: 46) for example the questionnaire which is also the most commonly used method in quantitative research. The interview is referred to as the oral questionnaire (Best & Kahn 1993: 251) and is preferred in qualitative research because of its flexibility. The interviewer usually structures sessions loosely to allow the interviewees to discuss events that are important to them (Morse 1994: 46). The researcher is the key instrument for data collection (Tierney & Lincoln 1994: 110; Roy 1991: 105). This enhances flexibility in that the researcher may design subsequent questions based on the previous answer as well as the non-verbal expressions.

Being a multiple method approach, all three methods are usually used in a single study to complement each other. Document analysis, for example, provides insights into the setting and supports other data (Whitt 1991: 411). This enhances the credibility of the study by triangulation of methods. At times, conventionally positivistic methods such as questionnaires are also used in qualitative studies. Where used, they are either used as complementary methods for purposes of triangulation, or

as follow-up methods to further examine the phenomenon being studied.

Qualitative researchers collect data by interacting with people and by obtaining relevant documents (McMillan & Schumacher 1993: 372-373). Sources of data are, therefore, information-rich persons and archival documents. Information-rich persons are selected by purposive sampling whereby the researcher purposively selects individuals who are knowledgeable of the subject under study. Snow-ball also referred to as net work sampling is then used, which means that one interviewee suggests the next person(s) who can provide relevant information. It is also called sampling by referrals (McMillan & Schumacher 1993: 378-381). Crowley (1995: 59) suggests case sampling and criterion sampling as two additional sampling methods that can be used. These are sampling based on a case and those based on certain criteria, such as age or gender. McMillan and Schumacher (1993: 382) further suggest that sampling is dynamic and the sample size depends on the following factors: the purpose of the study, the focus, the primary data collection strategy and availability of informants.

Data collection ends when information begins to become redundant. The researcher starts with a minimum data, analyses it and has it critiqued by peers in which case the researcher continues to add to the sample as the study progresses, if deemed necessary. When the information collected from different sources begins to become repetitive, it is an indication to end data collection as there is no more new information.

McMillan and Schumacher (1993: 383) further suggest five data collection phases which occur in somewhat overlapping circles. These are:

1. planning, which is the analysis of the problem and the anticipated research questions;

2. beginning data collection, establishing rapport, trust, and reciprocal relations with the individuals and groups to be observed;
3. basic data collection, beginning to hear, read, and see what is going on;
4. closing data collection which depends on data collected and the study; and
5. completion which blends into formal data analysis and construction of meaningful ways to present the data.

These phases assist to ensure the attributes of a good study as suggested by Eisenhart and Howe (1992: 648) in section 3.2.1. They further imply an iterative approach in qualitative research methodology even during data analysis.

### **3.2.3 Data Analysis Techniques**

Discussing data management and analysis, Crowley (1995: 62) and Bradley (1993: 444) contend that one of the hallmarks of qualitative research is abundant data generated through interviews, document analysis and observation. Analysis of such data is not an easy task. Furthermore, data is usually narrative (Anderson 1994: 231), that is, it is non-numerical, in the form of words which, is more problematic than numbers because they are normally richer in, and have multiple meanings (Miles and Huberman (1994: 56). This makes them harder to move around yet still some are meaningless unless they are moved backwards and forwards. Iterative analysis is therefore suggested (Fidel 1993: 227) whereby data analysis is not relegated to after completion of data collection but goes on through the study and guides further data collection. It is ongoing and influences further data collection (Morse 1994: 47).

Mackay and Schuh (1991: 428) and Whitt (1991: 412) also argue that data analysis and data collection in qualitative research are inseparable but are conducted concurrently. It is a cyclical, integrated process according to Westbrook (1994: 245). It involves "...working with data, organising it, breaking it into manageable units,



searching for patterns, discovering what is important and what is to be learned, and deciding what to tell to others” (Westbrook 1994: 245). The purpose is to understand not to predict.

Because of the abundance of data obtained in qualitative research, Crowley (1995: 63) suggested the following ways of analysing the data:

- analysing domains, which involves looking for clusters or categories of meaning from the data;
- organising or identifying ways the domains are organised;
- doing component analysis, which involves the search for attributes in a domain;
- doing thematic analysis, that is, searching for relations among domains and how they are related to the larger culture; and
- going back and forth during the course of the study to check on various meanings and possible relationships, which is referred to as iterative data analysis.

Crowley (1995: 63, 64) also refers to Miles and Huberman’s suggested use of matrices whereby a matrix is selected on the basis that it will display the data required by the research purpose such as role by time matrices, role by group matrices, effects matrices and site dynamic matrices. According to Crowley (1995: 64), these are ways of displaying data in charts which help researchers to cluster their observations during analysis.

Miles and Huberman (1994; 245-262), in an expanded form, discuss thirteen tactics of generating meaning from qualitative data, which is basically analysing the data.

These are arranged from the descriptive to the explanatory as follows:

1. noting patterns or themes;
2. seeing plausibility;
3. clustering;
4. making metaphors;
5. counting;
6. making contrasts;
7. partitioning variables;
8. subsuming particulars into the general;
9. factoring;
10. noting relations between variables;
11. finding intervening variables;
12. building a logical chain of evidence; and
13. making conceptual/theoretical coherence.

In doing all this qualitative researchers do a lot of "writing-up" in all phases of the research process (Bradley 1993: 446), which is also referred to by Hasselkus (1995: 81) as "thick description" not necessarily meaning masses of data but layers and layers of meaning. Informal "write-up" exercises serve both to articulate one's thoughts and to record them for review later.

Data analysis therefore, in qualitative research, requires planning and takes time. It involves moving forwards and backwards in an iterative approach. In doing so themes, domains, patterns, categories and intervening variables are identified which bring logical meaning to the volumes of data obtained in qualitative research. In the process, due the volumes of data from eclectic sources and the role of researcher as the main research instrument, it is imperative to ensure the trustworthiness and authenticity of the data. The next section discusses trustworthiness and authenticity.

### 3.2.4 Trustworthiness and Authenticity of Research Results

Qualitative researchers must answer the important question, "How can an inquirer persuade his or her audiences (including self) that the findings of an inquiry are worthy paying attention to?" (Lincoln and Guba in Whitt 1991: 413). This is necessary because the principles and methods on which research is based involve: seeking understanding; allowing the research design to emerge as the study progresses; using a human instrument to study natural settings and relying primarily on interviews with respondents.

These make it very difficult to adhere to traditional credibility in qualitative research. Eisenhart and Howe (1992: 646-651) having outlined attributes of good research as: completeness, appropriateness, clarity, comprehensiveness, credibility and significance (section 3.2.1); also refer to Lincoln and Guba for their definition of trustworthiness which is the same as the one given by Whitt (1991: 413) above. Lincoln and Guba, however, emphasise two "directives of a naturalistic research" namely, no manipulation of the conditions of the study, and no imposition of *a priori* categories on the result of the study. This makes the question of trustworthiness even more complicated.

Lincoln and Guba ( in Whitt 1991: 413), Bradley (1993: 436), Crowley (1995: 59) and Glinner (1992: 80), however, suggest the following criteria for trustworthiness: credibility, transferability, dependability and confirmability.

According to Bradley (1993: 436), credibility refers to the adequate representation of the constructions of the social world under study assessed both in terms of the process used in eliciting those representations and in terms of the credibility of those representations for the community under study. In simple terms Whitt (1991: 413) refers to credibility as the researcher's interpretations being credible to the

respondents. Bradley (1993: 436) and Westbrook (1994: 251) suggest the following activities that enhance the credibility of a study and its results:

- prolonged stay in the field, which refers to staying in the field of study long enough until the researcher ensures that all the data related to the study has been collected;
- persistent observation, which refers to observing purposefully and continuously until the researcher is sure all the behaviour related to the phenomenon under study has been discovered;
- triangulation of either methods, observers or data sources, which refers to using various methods of data collection or varying the data sources or observers;
- searching for negative cases, referring to the process of refining a hypothesis until it accounts for all the known cases related to the study;
- debriefing with peers, which is exposing oneself to peers who may not be primarily interested in the study, for purposes of exposing aspects not clear in the researcher's mind; and
- checking of results with members of the community under study, which entails providing the conclusions of a study to members of the group that was studied for purposes of checking categories, interpretations and conclusions.

Other authors such as Whitt (1991: 413), Crowley (1995: 59), Westbrook (1994: 251), Hasselkus (1995: 77, 78), Gliner (1994: 84) and Manning (1997: 100-105) variously refer to these activities as prolonged stay, triangulation, negative case analysis, peer debriefing, and member checks. They are also referred to, by other authors, as general criteria for trustworthiness, such as triangulation for confirmability by Wolcott (1992: 21). Triangulation is the commonest activity and could take any of the following forms:

- triangulation of data sources, where data is collected from different but similar sources;
- triangulation of investigators, which refers to using more than one observer to collect the data;
- triangulation of methods, usually used as a combination of qualitative and quantitative approaches as well as other methods within the qualitative tradition such as document analysis, observation and interviews; and
- triangulation of theory, in which different theories may be applied to test the validity of the data borrowing from what is available in literature.

The disadvantage of triangulation is that it usually requires a great length of time for data collection (Wilson & Hutchinson 1991: 274) and prolonged engagement may be subject to subjective interpretations as well as the second kind of researcher effect which stems from the effects of the site or the setting on the researcher (Miles & Huberman 1994: 266). This latter effect is the second of the two possible researcher effects in qualitative research. The first one is the influence of the researcher on the case, site or setting being studied when the researcher's presence threatens or disrupts the social setting (Miles & Huberman 1994: 265). The converse is the second effect resulting occasionally from the researcher's sensitivity to effect one and spending time to avert the effect with the result that he or she becomes co-opted or swallowed up in the local setting (Miles & Huberman 1994: 264).

Transferability, according to Bradley (1993: 436) refers to the extent that the researcher's working hypotheses about one context apply to another. According to Whitt (1991: 413) this refers to the study's usefulness in another context. This can be accomplished through replication and is equivalent to external validity, the only approximation to generalisation (Gliner 1994: 88).

Dependability refers to both the coherence of the internal processes and the way the

researcher accounts for changing conditions in the phenomenon (Bradley 1993: 437). Simply stated it refers to the taking into account of the changes over time (Whitt 1991: 413).

The fourth criteria is confirmability which refers to the extent to which the characteristics of the data, as posited by the researcher, can be confirmed by others who read or review the research results (Bradley 1993: 437). This in brief means that the results can be confirmed by someone other than the researcher (Whitt 1991: 414).

Thus, as Fidel (1993: 233) contends, qualitative research is scientific in that it is not impressionistic, off-cut analysis based on a superficial look at a setting of people. It is quite demanding though not necessarily standardised. All the three common approaches, observation, interviewing and document analysis involve more than the face values of the terms. Miles and Huberman (1994: 277-280) suggest the following standards for quality conclusions: objectivity or confirmability; reliability, dependability or auditability; internal validity, credibility or authenticity; external validity, transferability or fittingness; utilisation, application or action orientation. In this vein they contend that the ultimate test of credibility of a study results is its use by policy-makers (Miles & Huberman 1994: 280).

Closely associated with trustworthiness and authenticity are issues that have to do with the manner the research is conducted in the field by the researcher. These issues, referred to as ethical issues are the subject of discussion in the next section.

### **3.2.5 Ethical Issues**

Subjectivity plays a role in qualitative research since human instruments and respondents are involved. In addition, because of the same reasons, there are other important ethical issues when conducting qualitative research. According to Smith

and Glass (Eisenhart & Howe 1992: 654), one of the issues that should be considered in assessing the quality of naturalistic studies is the researcher's subjectivity and biases. This is because, as Whitt (1991: 408) argues, inquiry is value-laden rather than value-free. The researcher has certain biases and beliefs about the subject which can not be ignored since they have an effect on the way the study is conducted.

Subjectivity is the basis of the researcher's distinctive contribution coming from linking personal contributions to the data collected and analysed (Peshkin in Eisenhart & Howe 1992: 659). Hermeneutics, which according to Hultigren (1993: 21) refers to a philosophy and theory of understanding rooted in modes of understanding that have to do with one's way of being-in-the-world, "does not seek to translate one's own subjectivity out of the picture, but rather to take it up with a new sense of responsibility" (Hultigren 1993: 30). This is what McMillan and Schumacher (1993: 392) refer to as disciplined subjectivity or researcher self-monitoring. They state that some researchers write out all their potential biases about the topic before they begin the study. This in itself is a rigorous activity. It is, however, one of the criteria to enhance internal validity.

Other ethical issues to which qualitative researchers should be sensitive due to the emergent nature of their design and being face-to-face with those studied and which have to be considered throughout the phases of the study (McMillan and Schumacher 1993: 397-400; Whitt 1991: 414) include:

- informed consent, whereby every participant is informed of the purpose of the study and assured of confidentiality and anonymity;
- avoiding deception, but ensuring privacy and empowerment of the respondent. This refers to the question of honesty (Deyhle *et al.* 1992: 623), how the researcher presents oneself in the field and whether it is ethical to gain knowledge through deception which one would otherwise not be able to get?
- avoiding causing harm to the respondents, but acting in a caring manner and in

fairness with a sense of responsibility for what might be the outcome as well as for what might go wrong;

- ensuring a fair return usually in the form of results in the final instance but also showing appreciation for the opportunity to conduct research, and any other favours, services and privileges extended by the respondent to the researcher.

Whitt (1991: 414) refers to Fetterman who suggested two additional criteria, which is trust that creates a conducive atmosphere for conducting the research and related is to confidentiality and honesty. The other is rigour which refers to doing a good work despite the pressures, people and finite energy levels. An additional ethical issue has to do with recording an interview without consent of the informant. Best and Kahn (1993: 202) argue that it is unethical to record an interview without the consent of the informant.

Researchers, according to McMillan and Schumacher (1993: 400), need to identify potential ethical dilemmas and find ways of resolving them. Frequently, as Deyhle *et al.* (1992: 638) observe, these issues are not considered in the initial phases of the study until one has to make choices. Later it is recognised that these choices were ethical decisions having previously appeared as methodological or strategic decisions.

All the ethical issues have clear implications not only for conducting research but also for analysis and the quality of conclusions (Miles & Huberman 1994: 297). It is therefore, important to deal with them effectively in the planning of the research. This includes, according to Miles and Huberman (1994: 297), advanced thinking about them during the early stages of the project design, heightened awareness, negotiation, and making trade-offs among ethical dilemmas rather than application of rules. There is no uniform way of dealing with all the ethical issues in qualitative research since they differ for different situations. Understanding, being aware of them and taking them into account during the planning and execution of the research is what is of



essence.

Once data has been collected it has to be presented in some meaningful manner so as to be of value and have meaning to the audiences who are expected to use the research findings. From the foregoing narrative it is evident that the quantitative research methods of presenting data which include mainly tables and statistical methods may not work as easily in qualitative research as in quantitative research. The next section presents the discussion of data presentation methods.

### **3.2.6 Data Presentation**

Because of the abundance of data generated in qualitative research (Crowley 1995: 62), data presentation like analysis is not an easy task yet the findings have to be reported in such a way that they are meaningful to the readers and that they are considered by peers to be a valuable contribution to the discipline being researched (Remenyi & Money 1996: 208). Presentation of data is, therefore, a vital step in qualitative research process as proposed by Tuckman (1994: 391), that should not be taken lightly.

Since qualitative research is so diverse and cumbersome (Bradley 1993: 447) and contains data overload (Miles & Huberman 1994: 56), it is difficult to present large arrays of raw data to the readers. The research purpose should direct the balance in the data presentation (Bradley 1993: 447). This would imply a rigorous procedure of deciphering the data including the use of codes defined operationally (Miles & Huberman 1994: 65) and terms or categories, which are groups of words with similar meaning and/or connotation. Also themes are implied referring to clusters of categories sharing some commonality (Westbrook 1994: 246) which are efficient ways of data-labelling and data-retrieval devices. Matrices (Crowley 1995: 64), already referred to in section 3.2.3 are ways of summarising data in understandable

ways for the sake of theory development and testing (Richards & Richards 1991: 254).

Since qualitative research is non-numerical and inductive whereby, as gaps in the researcher's understanding become apparent they necessitate further research (Whitt 1991: 408), the researcher has to be able to determine when to end the study. This is not an easy task as generally research is continuous - an easy trap to fall into (Remenyi & Money 1996: 212). It is, however, accomplished when data becomes redundant, that is when repetition begins to appear and no new data appears (Crowley 1995: 64).

Qualitative research methodology, although a relatively new approach, has a philosophical basis also referred to as traditions which make it part of scientific research. The traditions are mainly classified into three paradigms based on the type of the phenomenon being investigated. These are investigation of lived experience, investigation of society and culture and investigation of language and communication. If qualitative study is a good study in whichever tradition, it should be complete, comprehensive, appropriate, clear, credible, and significant (section 3.2.1). In order to achieve these attributes, attention has to be paid to the data gathering and data analysis methods, and to the authenticity and trustworthiness of the results. These are important if the results and the study as a whole is to be considered of value to the audiences that receive it. Criteria for trustworthiness include credibility, transferability, dependability, and confirmability. These are in turn achieved through prolonged stay in the field by the researcher; persistent observation; triangulation of methods, observer or data sources; searching for negative cases; peer debriefing; and member checks. Additionally, there are ethical issues such as informed consent; confidentiality; avoidance of deception; and fair play and caring for the informant which enhance the authenticity of the study and its results.

Having taken these issues into account, a research methodology is chosen. Neglecting to take cognisance of them may result in applying a wrong methodology. The next sections present the design of the present study.

### **3.3 DESIGN OF THE PRESENT STUDY**

In this section the design of the present study will be described including sampling, data collection and analysis, and data presentation. As already indicated in section 1.8 the design followed a qualitative approach whose details are described in the following sections.

#### **3.3.1 Introduction**

Based on the reasons already cited, the researcher decided to adopt the qualitative research methodology in the present study with the purpose of an in-depth understanding of the phenomenon. Despite being a relatively recent research methodology compared to the quantitative research methodology it has been used effectively in educational research, for example, Barbara Duff's (1990) study "Women in Educational Management: Barriers, Aspirations, Motivation and Needs", and E. M. Lemmer's (1989) study "The Reentry of Women in the Labour Market and the Implications for Educational Provision". In both of these studies the aim was in-depth understanding and involved a small sample. Similarly, the same method was used beginning with the selection of the population and the sample. The rationale for the choice of the method and the research design used in the present study are described below.

#### **3.3.2 Choice of Method**

Qualitative research methodology was chosen for this study, mainly because although

there is not much qualitative research on higher education, Whitt (1991: 409) contends that it is apt for understanding universities and colleges, which are the subjects of this study. Furthermore it was chosen because of the nature of the problem. Westbrook (1994: 242) argues that it is the research problem that determines the research approach to be used. The goal of problem under study was an in-depth understanding of the management of the subjects and their missions. The philosophical orientation of the study as advocated by Tierney and Lincoln (1994: 110) is a phenomenological interpretation of the problem. Phenomenological interpretation implies understanding or gaining the insider's view as discussed in section 3.2.2 and is usually accomplished through the application of multiple methods. In addition the method borrows from ethnography, event structure analysis, and ethnographic content analysis traditions as discussed in section 3.2.2.

Another factor that led to the choice of the qualitative research method as suitable for this study was the size of the sample which was not large since the phenomenon of private degree granting institutions in the region of study is still very recent. The field has had little probing so far in form of research in education although it had gained substantial public interest in the region. It is hoped that the study will form a basis for further research on the subject and for policy formulation. A strength of qualitative research is "its ability to probe the policy /practice interface and thus inform policy makers" (Crossley & Vulliamy 1997: 13). The choice of the method was made with due awareness of researcher effects which may influence the findings. One of the suggestions to overcome these influences is to mention the researcher's experiences, values and training. This is the subject of the next sections.

### **3.3.3 Researcher Effects**

The researcher in qualitative research is the key instrument for the collection of data (Mackay & Schuh 1991: 425; Roy 1991: 105; Deyhle *et al.* 1992: 623; Lemmer 1992:

294; Orora 1992: 33; Webb-Mitchell 1992: 253; Sutton 1993: 416; Miles & Huberman 1994: 7; Morse 1994: 48; Tierney & Lincoln 1994: 110; Tuckman 1994: 388). Much therefore depends on what is seen and heard by the researcher based on personal observational and listening powers. The researcher remains a person with values, beliefs and self, despite trying to be a finely tuned instrument for the collection of data (Hammersley *et al.* 1994: 59). This implies that the researcher's subjectivity may influence the research design and the results and consequently have an effect on the validity of the research. Because of this a statement of the researcher's background characteristics and values is expedient.

### **3.3.4 Statement of Subjectivity, Researcher's Own Experiences, Values And Training**

Among the nine points which are listed by Wolcott (1990: 129) that help to satisfy the implicit challenge to validity is being candid and opting for subjectivity as a strength rather than detached objectivity. Peshkin (1988: 19) stated that subjectivity is the basis for the researcher's distinctive contribution coming from joining personal interpretations with the data that is collected and analysed. It is, however, not a matter of combination only but being able to rise above one's biases and subjectivity to examine the phenomenon under study as it is and to see human artifacts as distinct from other objects because they reflect intentionality and future oriented actions (Jansen & Peshkin 1992: 686). Such "disciplined subjectivity" is cited by Mcmillan and Schumacher (1993: 391) as one of the measures that increase validity.

The factors that influence the researcher's subjectivity include the researcher's experiences, training and values. The following is a discussion of these factors.

### *3.3.4.1 Researcher's Training and Experience*

The researcher was trained as a teacher of mathematics and chemistry and later developed an interest in educational administration, planning and management. The researcher currently holds two degrees in Educational Management (Administration) and has been involved in numerous seminars on the subject as a facilitator as well as a participant mainly in the area of private education.

The researcher's interest in educational management arose from his involvement in educational management after his initial teacher training. Trying to do his best with only minimal training as an administrator, the researcher developed the an interest in acquiring training in that occupation hence his further training in educational administration, planning and management. The researcher's interest in private education is demonstrated by his research for the Master's degree (Kibuuka 1987: 1) which concerns the academic performance of private secondary schools.

Since then the researcher has been involved in management at various levels. This includes involvement at school level with various responsibilities and at national level and regional level in church educational departments which is the researcher's current occupation. In these capacities the researcher has been involved in managerial responsibilities, lecturing and attendance at numerous educational management and other educational seminars as participant as well as facilitator. This experience has inevitably been beneficial in the current research. The research has also had and is hoped to continue to have a reciprocal effect on the researcher's experience and work. The researcher's current work includes planning for and supervision of tertiary institutions up to university level which are under the researcher's jurisdiction as well as planning for and participating in their evaluation.

### *3.3.4.2 Researcher's Values*

Subjectivity not only involves the researcher's experiences and training but also and very importantly the researcher's values which are inextricably interwoven with an individual's world view and cannot be separated from the research process (Lemmer 1989: 137). They should not be hidden from the reader so that the reader may be able to assess their effect on the research (Duff, 1990: 90).

The current researcher's interest in the subject of this research arose out of his interest in higher education, private education and as a Christian, in the interest of religious bodies' contribution to education. The researcher is a believer in God, the Bible and in the contribution of religious beliefs and organisations to all aspects of life. As an educator the interest in such a contribution to education can be ratified. On the other hand the researcher believes in proper and high standards in education rather than mediocre education standards. These are determined by credible practice, policy, goals and purpose, hence the interest in mission statement. With this background the present study was designed as explicated in the next sections.

### **3.3.5 Population and Sample**

As observed in section 3.2.2, the choice of the population in qualitative research studies depends on:

- the purpose of the study;
- the focus of the study;
- the primary data collection method;
- availability of informants;
- including more informants as long as information does not become redundant, that is, starting with minimum and having the number grow as the study

progresses and as needed (McMillan & Schumacher, 1993: 382).

Based on the above and particularly the purpose of the study and its focus, the population for this study included all the degree granting private religious tertiary institutions in Eastern and Southern Africa. More specifically, the countries of Kenya, Uganda and Zimbabwe made up the population because of their current policies on the establishment of private tertiary institutions including universities which appears to be more favourable than before. Since the establishment of such institutions is still a new concept there are not many of such institutions. The sample therefore also included all such institutions in the region. The informants were administrators/managers of these institutions who included heads of the institutions, board chairpersons, assistants in administration and leaders of the religious bodies which are involved in operating such institutions. The sample was not a big one since the object of the study was to acquire an in-depth understanding of the phenomenon and for such qualitative studies it is not the size of the sample but its quality that matters. It was also discovered during the course of the study that it was not necessary to contact all the informants as the data gathered began to become repetitive from one sample to the next.

Selection of informants was not based on random sampling but purposeful sampling in which the researcher chose information-rich individuals who would be able to provide the information required. Such sampling requires prior knowledge of the informants (McMillan & Schumacher 1993: 378). The experience of the researcher was helpful in knowing who to select. Other informants, particularly those within the institution, were also selected by snowball and purposive sampling techniques which involved subsequent informants being recommended by the antecedent informant. Those selected by purposive sampling were mainly the heads of the institutions or chief executives, commonly referred to as Vice Chancellors or Rectors who then advised on the structure of management of their institutions and recommended others



who would provide useful relevant information for the study. Another factor that is important is how the researcher reached the informants and obtained access to the information sources. This is referred to as access or entry and is the subject of the next section.

### **3.3.6 Access and Entry**

Access and entry refer to the process by which the researcher gains entry to where the sample is and meets the information-rich informants. The process depends on the kind of sample, the methods of data collection, the nature of informants and the domain of the study. For the present study access and entry involved initially seeking official permission to conduct research in the countries involved. Each of the country forming part of the population requires researchers, particularly those conducting research with human participants, to apply and receive permission before going ahead with the research. This process includes filling in a form, paying a fee, and waiting for the application to be assessed and to be given the official permission. The process differs slightly in strictness and procedure in the three countries that formed the population domain. Zimbabwe and Kenya require the researcher who is not a national or student in the country to be affiliated to a local institution. Kenya lists the institution to which such a researcher has to be affiliated. Zimbabwe does not list the institutions but it is understood that these include those institutions which are recognised by the government. This requirement in Uganda is not strongly enforced. Kenya and Uganda require the application to be scrutinised by the president's office for security reasons. Zimbabwe does not state this requirement directly but takes care of it within the process of approval. The bodies that are responsible for processing such applications in the various countries are referred to differently in each country. In Kenya the body is referred to as the National Council for Science and Technology, Research Committee, in the Office of the President. In Uganda the body is known as the Uganda National Council for Science and Technology. In Zimbabwe it is The

Research Council of Zimbabwe. A letter of introduction from the university in which the applicant was studying was required to be attached to the application. Copies of these letters are attached in the appendices B1, B2, B3 and B4.

After obtaining such permission the researcher visited offices of Ministries of Education to obtain information on the names, numbers, status and location of the sample institutions. Both Kenya and Zimbabwe had established bodies that are responsible for regulating the establishment of private universities and other tertiary institutions as observed in sections 2.6.1, 2.6.2 and 2.6.3. These are the Commission for Higher Education and the National Council for Higher Education in Kenya and Zimbabwe respectively. At the time of the study Uganda had not yet established such a body despite the recommendation that such a body be established by the education policy review commission. In order to streamline the development and management of tertiary education in the country and make it more effective and efficient, a national council for higher education has been recommended (Ministry of Education 1989: 73-74). On a subsequent visit to the Uganda Ministry of Education the researcher was informed that a bill for establishing a National Council for Higher Education had been drafted and approved by the Ministry's top management and was awaiting presentation to Cabinet and Parliament for final approval and implementation. Offices of these bodies, where they existed, were visited by the researcher in addition and/or on advice of the respective ministries of education to obtain more information on the institutions under study. Personnel in these offices were very helpful in supplying the required information. This may have been due to their kind of work, that they were still new bodies and their interest in the development of policy on the regulation and control of tertiary private institutions. They also provided many relevant documents on the subject of research and were visited more than once during the course of the study.

Having obtained this information the researcher sent letters of introduction to the

heads of the institutions seeking an appointment for conducting an interview with them (appendix B). Some of these letters were delivered by hand by the researcher but most of them were sent by post. In some cases where the letters were personally delivered the researcher secured an appointment upon presentation of the letters; other appointments were fixed for a future date. In a few other cases appointments were fixed in writing and in others by a follow-up telephone contact. The level of cooperation in all cases was satisfactory. The researcher believes that it was mainly due to the nature and caliber of the informants who are academics and interested parties in this kind of research. Only in one case was the researcher requested for identification. In another the informants who included the chief administrator of the institution together with a dean of one of the schools, at the suggestion of the chief administrator, would not allow the recording of the interview although they cooperatively provided all the information required after examining the interview schedule. All other informants trusted the researcher on face value and on the strength of the letters of introduction from the University and the letters of permission from the respective national research bodies. At the end of the interviews the key informants were requested to supply names of other information-rich individuals who could be contacted either for an interview or by a questionnaire (appendix C2). The researcher prepared this questionnaire to be used for such other informants due to the difficulty of meeting them owing to the vastness of the population territory. The questionnaire also served the purpose of triangulation of methods which enhances trustworthiness and credibility. Some of key informants volunteered such recommendations before being requested. The next section presents the data collection methods used after all the necessary preparations were made.

### **3.3.7 Data Collection**

The main data collection method which was used in the current study was semi-structured interviews. However, following a multi-method approach as indicated in

sections 1.4 and 3.2.2, observations, document analysis and questionnaires were also used. This triangulation of methods was one of the ways used to corroborate the results, and as seen in section 3.2.4, triangulation was a way to increase credibility of the results and to enhance trustworthiness. The interview was, however, the main research data collection method although it was cumbersome. The next section describes how the interviews were conducted.

### 3.3.7.1 *The Interview*

(Spradley in Borg & Gall 1989: 397) defines interviews (specifically ethnographic interviews) as a series of friendly conversations in which the investigator gradually introduces new elements in order to gain the information sought. It is also referred to as a conversation with a purpose (Bogdan & Biklen 1992: 96) or an oral questionnaire (Best & Kahn 1993: 251; Morse 1994: 46).

Morse (1994: 49) identifies the following four types of interviews which can be applied in qualitative research in a form of sequence:

1. exploring interviews, which are used to build trust in the research more than obtaining information so that the respondent does not feel that the research is judgmental;
2. focussing interviews, which, following the exploring interviews help to focus on issues raised during the exploring interviews;
3. crystallising interviews, referring to obtaining the data on the crucial issues being researched; and
4. verifying interviews, which involve examining the data in a collaborative manner with the respondents.

These would apply mainly when the research deals with topics which may cause

participants to be rather apprehensive. On the other hand Wilson and Hutchinson (1991: 270) talk of formal and informal interviews which are also referred to as structured and open, unstructured interviews. The open type is preferred to the structured one because, according to Burgess (in Bogdan & Biklen 1992: 96), in the hands of the qualitative researcher the interview takes the shape of its own which is the crux of qualitative research. The unstructured interview best suits a qualitative paradigm (Borg and Gall 1989: 397). Fidel (1993: 233) contends that such interviews are not comprised by simply asking questions but the goal is to acquire rich and varied data which is obtained by interviewing the informants for one to two hours preferably in a place of their own choice. Wilson and Hutchinson (1991: 270) also refer to the aim of in-depth interviewing as understanding relationships and rapid changes in organisational structures (Roy 1991: 105; Ormala (1994: 46). Elite interviews are recommended by McMillan and Schumacher (1993: 427) for studies that seek in-depth understanding because they focus on individuals who are considered influential, prominent, well informed and familiar with the organisation under study and its relationships with others. Elite exploring interviews were preferred for the present study because an in-depth understanding of private religious institutions and their management as it relates to their mission was sought. There were elements of focussing, crystallising and verifying in the interview in order to enhance understanding but the main emphasis was on exploring. The informants in this study, who were primarily the heads of the institutions and others who were knowledgeable, were considered elites since they are well informed and familiar with their organisations.

An interview schedule (appendix D) was developed to act as a guide during the interview sessions. It was, however, not followed strictly so as to allow the informants to provide information without being restricted to a given design which is a characteristic of positivistic approach. The procedure was, therefore flexible but intensive. The interview was conducted like a conversation but focussed on the

mission of the institutions, their development, and their management. The length of the interview varied from one instance to another but averaged about forty five minutes to one and a half hours. In one case the interview had to be rushed because the informant had to attend to a regular religious function which was scheduled shortly after the interview. He, however, had earlier referred the researcher to other assistants in administration for more information.

Upon arrival at the institutions and the researcher was ushered into the chief executives' office or into the office of a designee, who in all the four cases where this happened were the academic registrars. After introduction, the researcher explained the purpose of the study referring to the letters of introduction. In most cases the letters were already in the possession of the informant. In no case did the researcher meet with hostility. In one case the researcher was requested to provide identification as seen in section 3.3.6. In another case the researcher was referred to the academic registrar who had been with the institution longer as he was considered more able to provide the required information. The vice chancellor of this institution, at the time of the study, had been recently appointed to the position at that institution. Since it was not easy to record in writing all the responses the respondents gave during the interview, a tape recorder was used to record the responses. As Best and Kahn (1993: 202, 253) contend recording the responses reduces distractions if writing takes place during the interview. Consent of the informants to record the interview was, however, obtained before starting the interview since it is unethical to record an interview without the informant's consent (Best & Kahn 1993: 202, 253). In one case this was not permitted as already observed in section 3.3.6.

While setting up the tape recorder, the researcher continued to have a general and informal discussion with the informant about the institution and its management before commencing the formal interview. This was, in most cases like a continuation of the informal discussion.

The interviews, in most cases, were conducted in the offices of the chief executives or their designees. This did not take place without interruptions as is true of most natural settings preferred for qualitative research since these offices are usually very busy places. Most of these interruptions were telephone calls and in a few cases the secretary entered to inquire about certain items or to bring some information. The latter was, however, minimal as most informants had informed their secretaries that they were busy and treated the interview with due seriousness. Many informants ordered a drink for the researcher, sometimes with the consent of the researcher and in other cases, without. It was not easy to take a drink while conducting an interview yet the courtesy of the informant had to be respected. In most cases the drink was taken after the interview while recapping it. In naturalistic inquiry interruptions are not regarded as interference since they may be a clue to organisational culture (Davies 1997: 142). Instead they are taken into account and at times recorded depending on the object of the study. A few of the informants decided to use a place other than their offices in order to minimise such interruptions. The choice of the setting for the interview was left to the informant since it had little to do with the aim of the study. In all cases, however, the researcher had opportunity to enter the informant's office and observe how it was arranged and observe any artifacts. The latter can be a clue to the general cache of the school as well as the chief executive's leadership style (Davies 1997: 140). Some informants took time to take the researcher around their campuses to some of the significant areas of the institutions which had specific historical significance and to meet other significant personnel. At the end of the interview the informants were asked if there were any parts of the interview which they were not comfortable with so that they could be erased from the record. In no case was any informant uncomfortable with anything. They were then requested and agreed to distribute a prepared questionnaire to their associates in administration, to management chairmen and to religious leaders. Most of the informants volunteered more information in the form of documents and in the few cases where this did not happen, the researcher requested documents such as the institution's written mission

statement, institution bulletins and various handbooks.

The recorded interviews were listened to soon after the interviews and transcribed by the researcher in conjunction with the brief notes taken during the interview. In doing so the researcher discovered areas in which subsequent interviews had to be modified and conducted. In a few cases there was need for a subsequent interview or some form of follow-up of the interview which the researcher did by either returning to the location, phoning or in writing. The next prominent method of data collection which was also a means of triangulation to enhance credibility was document analysis.

### *3.3.7.2 Document Analysis*

In addition to the interview as the key research method for the collection of data, analysis of documents also played an important role. Authors on the subject of qualitative analysis emphasise the use of documents in qualitative research for collection of data as non-interactive methods (Tuckman 1994: 397; McMillan & Schumacher 1993: 373, 374; Bradley 1993: 441; Best & Kahn 1993: 191).

Documents include what others have created (Bogdan & Biklen 1992: 108) such as newspapers and media reports, committee minutes, policy documents, official letters, textbooks, announcements, bulletins and prospectus, and handbooks; and at times those created by the researcher. For purposes of this study, however documents referred to are those that had been created by others. Whitt (1991: 411) contends that the value of using documents in qualitative research is that they provide rich insights into the organisation and support other data; and should not be taken lightly (Wolcott 1992: 21). Harber (1997: 114) outlines the following advantages of using documents in qualitative research:

- they are convenient to use;
- they are often free or available at only a small cost;



- they can be collected in a shorter time; and
- they can be analysed when institutions are closed.

In addition documents can be collected and analysed long after the event occurred in which case they may be an advantage as well as a drawback because in such a case there is no way to cross-check the findings. That drawback notwithstanding analysis of documents in qualitative research is a useful method as triangulation to enhance validity of a study and its results. They also, for the present study, provided information about informants who were not easy to meet for an interview.

Analysis of documents, sometimes referred to as a review of documents (Morse 1994: 45) is also commonly referred to as “content analysis” (Fidel 1993: 233; Westbrook 1994: 243; Davies 1997: 156; Harber 1997: 120). Davies (1997: 156) adds that it is not only content analysis but also textual analysis aimed at the isolation of significant, recurrent vocabulary and metaphor which indicates the leader’s style.

For the present study the following documents were obtained and analysed though not for each institution: newspaper and media articles; institution’s bulletins, the prospectus and handbooks; official letters; government documents and parliamentary acts; policy documents and committee minutes.

These documents were obtained from the institutions themselves, from the ministries of education of the various countries (documents such as official letters, charters, government acts and other documents) the religious bodies responsible for universities, public libraries, archives and government printers. Newspaper articles were obtained from both current, referring to the period during which the study was conducted as well as old papers.

### 3.3.7.3 Observation

Another method that was used in the study was observation which Wolcott (1992: 19) simply defined as watching. Observation is cited as one of the methods of data collection in qualitative research (Fidel 1993: 222; Bradley 1993: 441, 442; Anderson *et al.* 1994: 108; Tuckman 1994: 397) and is useful as a triangulation method as well (Westbrook 1994: 251). Observation can either be participant observation when the observer gets involved in the situation in order to gain insights by developing interpersonal relationships which would be difficult to develop through any other method or nonparticipant observation in which the observer minimises interactions with the subjects being observed so that information is obtained less obtrusively (Best & Kahn 1993: 198; Hultigren 1993: 26; Borg & Gall 1989: 391, 396). Morse (1994: 45) contends that attendance at meetings may be regarded as observation.

In the present study the researcher used mainly nonparticipant observation upon arrival at the institutions. The period of observation varied from place to place ranging from about two hours to a full day. At institutions with which the researcher is acquainted through regular work, he had extended observation periods including a two week teaching assignment as adjunct lecturer. This gave the opportunity to observe more things as a participant observer. During some of these observation moments the researcher had opportunities to interact and hold some informal discussions with institutional personnel. Such interactions are useful in qualitative research (McMillan & Schummacher 1993: 372) since they serve as a means of checking rival explanations (Miles & Huberman 1994: 274). The researcher's membership of some of the sample institutional councils (governing boards) provided another opportunity for participant observation. The researcher also had the privilege of attending a world education summit in California which was organised by one of the religious organisations to discuss institutional mission development. All these moments provided valuable additional insights into the study.

#### 3.3.7.4 *The Questionnaire*

The questionnaire, unlike in the case of quantitative research, was not the primary data collection instrument. It was used as indicated in section 3.2.2, as a means of obtaining information from informants who the researcher was not able to meet personally as well as for collecting data from multiple data sources which is a form of triangulation of methods (Bradley 1993: 440).

A close-ended questionnaire, appendix C2, was developed and administered through the heads of the institutions to the other administrators and chairpersons of the governing bodies. On the average, five questionnaires were distributed to each institution for this purpose. The number was, however, less for some institutions which did not have as many members of the administration as others. The responses were to be posted back to the researcher in an enclosed, self-addressed stamped envelope. The information required by the questionnaire was similar to that required through interviewing.

All the data collected by the various methods should be presented in a meaningful way to the readers of the research. This is usually a challenge as observed in section 3.2.3 because of the multiple methods used as well as the volume of data collected. The following section presents how data analysis was done in the present study.

#### **3.3.8 Data Analysis**

Data analysis in qualitative research does not involve primarily working with numbers as in quantitative research but rather formally identifying themes and constructing hypotheses suggested by the data. It is also not relegated to the end of data collection (Fidel 1993: 227), but rather it is inseparable from it (Mackay & Schuh 1991: 428;

Whitt 1991: 412; Morse 1994: 47; Miles & Huberman 1994: 50). Data analysis in qualitative research is iterative (Crowley 1995: 63), taking place during data collection and guiding further data collection (Fidel 1993: 227).

Qualitative research is seeking to understand phenomenon from the participant's perspective (McMillan & Schumacher 1993: 15). Thus the process of data analysis involves unveiling human experience (Wilson & Hutchinson 1991: 271) via the various methods used in the collection of data taking in account subjectivity into data analysis (McMillan & Schumacher 1993: 15). According to Westbrook (1994: 245), data analysis involves "...working with data, organising it, breaking it into manageable units, synthesising it, searching for patterns, discovering what is important to be learned and deciding what to tell others". The first step of organising the data is an important one as data in qualitative research is usually voluminous and should to be carefully organised in order to be able to identify the themes within it and the subsequent formulation of hypotheses. It begins right in the field while data is still being collected by discovering chunks of meaning, which may be referred to as segments from which topics emerge and then categories and patterns of relationships between the categories.

The following characteristics are typical of qualitative data analysis:

- It is an inductive process in that the themes emerge from the data not from outside it (Tuckman 1994: 388; Fidel 1993: 231; Mackay & Schuh 1991: 424; Best & Kahn 1993: 203).
- It is a rigorous activity which involves many things such as synthesising, categorising and interpreting (Roy 1991: 106).
- It involves constant and systematic comparison (Bradley 1993: 445) by means of comparing and contrasting each category to determine and corroborate distinct characteristic of category and participant reality (McMillan &

Schumacher 1993: 391).

- It is an integrated process with data collection (Westbrook 1994: 245).

Regarding the present study, as soon as the data was collected on tapes, in most cases, the tapes were transcribed. Transcription took place on a computer which enabled several copies of the transcripts to be made for easy marking. At the end of data collection different coloured high-lighters were used to mark different emerging patterns which were later explored for categories and themes. This was done in comparison with the available literature to check for agreement and areas of contention and variance. Information and concepts gleaned from the preliminary data were integrated into subsequent interviews and where necessary, some institutions were revisited for clarification or contacted by phone or mail to supply additional information.

In the process of analysing the data of great concern is the credibility of the results to the audience. This is checked by ensuring the reliability and validity of the data which also ensure quality conclusions as seen in section 3.2.5. The following section presents how this was achieved in the present study.

### **3.3.9 Reliability and Validity**

Reliability, according to McMillan and Schumacher (1993: 385) refers to the extent to which independent researchers could discover the same phenomenon to which there is agreement between the researcher and the participants. It has to do with consistency of style and interpretation. It may be viewed as the fit between the recorded data and what occurred during the study.

Validity is defined as trustworthiness of the inferences drawn from the data (Eisenhart & Howe 1992: 644; Gliner 1994: 84). It depends on the extent to which data

represents the actual participants' subjective experience. It has to do with credibility and transferability (Gliner 1994: 84; Hasselkus 1995: 77), not generalisation (McMillan & Schumacher 1993: 394), and can be enhanced by participants' willingness to provide information in an atmosphere of trust. Wolcott (1990: 126-135) suggests the following nine ways which help to satisfy the implicit challenge to validity:

1. Listening more than talking;
2. Recording accurately;
3. Beginning writing early during the research;
4. Letting the readers see for themselves by including much primary data in the final script than simply the idea;
5. Reporting fully;
6. Being candid, thus opting for subjectivity rather than detached objectivity;
7. Seeking feedback by sharing the manuscript with informed readers, also referred to as peer examination or peer debriefing (Carspecken & Apple 1992:521; Hultigren 1993: 23; Manning 1997: 104);
8. Achieving balance;
9. Writing accurately.

Another method suggested to enhance validity is triangulation (Fidel 1993: 232; Hultigren 1993: 23). This involves the convergence and analysis of multiple data sources (Morse 1994: 48) or the use of different data collection methods (Steckler *et al.* 1992: 4, 5).

In the present study the researcher used both triangulation sources and methods as well as endeavouring to apply to varying degrees all the nine points suggested by Wolcott (1990: 126-135) above to enhance validity and reliability of the study and the results. In addition to interviewing information-rich individuals, observation and

analysing documents the researcher used a questionnaire which was sent to other administrators of the institutions included in the sample. At least three questionnaires were sent to each institution; the average, however, was five per institution depending on the number of assistants in administration at the institutions. The chairperson of the governing board was also included among those to whom a questionnaire was sent. Analysis and interpretation of findings was attempted uniformly with minimal disturbance to the natural flow of information. There was no evidence of informants being threatened by the research. A few were a bit apprehensive at the beginning of the interviews but quickly relaxed. When asked if they wanted to listen to the tape after the interview or wanted to erase anything from the tape, which was the case with all informants, none indicated a desire to do so. Instead most were supportive by supplying more documents than requested and suggesting other information-rich informants who could be interviewed or given the questionnaire. A few indicated a desire to receive a copy of the finished report of the study to which the researcher consented. There was no threat to validity due to what Borg and Gall (1989: 405) refer to as history, maturation, experimental mortality, and instrumentation with exception of some developments in one country where a procedure for accrediting private tertiary institutions was established, though not completed, during the study. This did not pose a threat to validity but rather showed the developmental nature of the subject of study. One useful method for enhancing validity that the researcher used more than others was peer examination. The researcher shared research findings and drafts of the thesis with others engaged in or familiar with similar research, studies or phenomena for comment which was willingly given by some.

### **3.3.10 Ethical Issues in the Current Design**

In the present study there were not many ethical issues to contend with. This was mainly because, although the study was dealing with human subjects, the nature of the study was not controversial. Nevertheless, issues of informed consent, honesty on the

part of the researcher, trust, fair return, anonymity and permission for recording the interview were considered and cared for.

The obtaining of research permits and sending letters seeking appointments for interviews were endeavours to obtain informed consent. In no case was the research conducted without the consent of the respondent. Both the respondents to the interviews and the questionnaire were given the opportunity to respond at free will. In addition the researcher did not attempt to use deceitful means to obtain data. Proper information and identification were always carried and shown when required.

As a means of fair return, the researcher expressed appreciation to the respondents for the opportunity to do research in their institutions at the end of the interviews and this is to be followed by a letter. Those who requested the final copy of the research report were recorded and the researcher plans to honour the promise made to send them a copy. It is also hoped that the findings and recommendations of the study will assist the respondents in their management of the institutions. The report, however, has tried to conceal the identity of the respondents for the sake of anonymity. Some respondents did not want their documents photocopied and indicated that they preferred to remain anonymous.

### **3.3.11 Trustworthiness in the Current Design**

Trustworthiness refers to the value of the study and its findings so that it becomes worthy of receiving the attention of others (section 3.2.4). In order to achieve this and in the tradition of qualitative research, the researcher approached the study with no *a priori* categories or manipulation of the conditions. This the researcher endeavoured to accomplish by letting the respondents decide the best conditions and venues for conducting the interview, which was the main data collection method.



Triangulation of data sources and methods has already been referred to in section 3.3.9 as a measure to achieve credibility in addition to other measures which included rigorous data collection and analysis. Conducting the study in institutions located in three countries with both similarities and differences in their history and current policies serves as a means of ensuring transferability, which in qualitative research is not synonymous to generalisability but to external validity (section 3.2.4). It is therefore hoped that the study can be replicated in other countries with more or less similar backgrounds.

In the process of the study the researcher kept on checking with some subjects as to the correctness of the findings for purposes of confirmability. This was not possible with all the subjects due to the vastness of the region covered. Additionally the use of triangulation of sources was also a measure to enhance confirmability.

#### **3.4 SUMMARY**

In this chapter a review of literature related to qualitative research methodology has been presented and the methodology of the current study described. The review was not restricted to the beginning of the chapter but was presented throughout the chapter as related to the study. It included a review of the historical background and the traditions of qualitative research. These were observed to be dependent on the type of phenomenon being investigated as seen in section 3.2.6 and are categorised into investigation of lived experience, investigation of society and culture and investigation of language and communication. The review also included literature related to data gathering and analysis methods. Data gathering methods were observed to depend on the purpose of the study, the focus and availability of informants. These, included all the conventional qualitative data gathering methods such as interviewing, document analysis, observation and at times the questionnaire. The interview was the primary data gathering method in this study but the other methods were also used for

purposes of triangulation of methods and sources of data. Data analysis was seen in section 3.2.3 as working with and organising the volumes of data into manageable units and deciding what to report to others. Not all data collected in qualitative research is included in the report because it is quite abundant. Data analysis includes sorting out what is worthy reporting to others. This process includes as observed in section 3.2.3 noting patterns or categories, seeing plausibility, clustering, making metaphors, counting, making contrast, partitioning variables, subsuming particulars into general, factoring, noting relations between variables, finding a logical chain of evidence and creating conceptual and theoretical coherence. Most of these were applied in the present study.

The review also covered literature related to concepts of trustworthiness, authenticity, researcher effects and ethical issues. Since the researcher is the key research instrument, it is imperative to consider these concepts in the study design. Suggested ways of ensuring trustworthiness and authenticity include ensuring prolonged stay in the field; persistent observation; using triangulation of methods, searching negative cases, and peer debriefing. All these were applied in the present study to varying degrees. However, triangulation of methods and sources of data was applied more prominently, as seen section 3.3.9. In order to minimise researcher effects, the researcher's subjective biases which included training, work and values of the researcher were explicated in the study. The researcher also endeavoured to work within ethically accepted norms of doing qualitative research which included informed consent, confidentiality, maintaining anonymity and ensuring fair return where applicable. The researcher, for example, plans to send a copy of the completed report to those who requested one when the study is completed.

Description of the methodology included an explication of the rationale for the choice and identifying of the population and the sample. Since the choice of the design depends on the population and sample to be studied, the size of the sample and

availability of the informants are other considerations taken into account when deciding on the method of study. In the present study the population included all degree granting religious private institutions and the informants were information-rich individuals who were chosen by purposive elite sampling, see section 3.3.7.1.

Other concepts covered in the choice and research design were how entry to the sample was achieved; data collection methods, with emphasis on the interview which was the main research methodology; and analysis as well as how reliability and validity were achieved for the present study. Unlike many social research endeavours, entry into the field for the present study was not a problem as the phenomenon being studied was of interest to many informants who were either involved in the process of policy making or in management of the institutions being studied. The requirement to acquire official permission to conduct research was acquired with minimal problems.

The chapter then concluded with a discussion of ethical issues and trustworthiness in the present study. The next chapters present and discusses the findings in the data collected in detail.

## **CHAPTER 4      RESEARCH FINDINGS: MANAGEMENT OF RELIGIOUS TERTIARY INSTITUTIONS**

### **4.1      INTRODUCTION**

The findings of this study are presented under two headings: Management of Religious Tertiary Institutions in the present chapter and Mission Statement of Private Religious Tertiary Institutions in chapter five. The idea of educational management although still a fairly recently developed discipline of study as compared to management in general (sections 2.2 and 2.3.2) is an important aspect of any educational institution of all levels. Much of what takes place in the educational institution depends on the nature of management and the success of the institution also depends on management. It has been defined in section 2.3 as a specific type of work in education which comprises those regulative tasks or actions executed by a person or body in a position of authority to allow formative education to take place. This type of work is particularly important in the case of the emerging phenomenon of private tertiary institutions, in general and the private religious tertiary institutions in particular. Private religious tertiary institutions operate in a dual system. They are managed by both the founding religious organisations and the governments of the countries where they are situated.

In this chapter findings related to management and development of religious tertiary institutions are presented under categories and sub-categories identified from document analysis as well as from the interviews and other methods used to collect data in this research. The chapter also presents a brief explication of the educational basic concepts of the religious group and includes presentation of the findings in an objective way after careful scrutiny (Bergh & Van Wyk 1997: 60). A proposed model for the management of private religious tertiary institutions is also given at the end of the chapter.

## **4.2 CATEGORIES IDENTIFIED**

As already indicated in section 3.3.7.2 data was collected using primarily the interview methods. However, following the multi-method approach, observations, document analysis and a questionnaire were used as well. As data from these data gathering methods was through clusters of similar responses emerged and these were grouped into patterns. These patterns were further examined and after comparing them with those from the literature study, they were further regrouped into categories. The following categories which relate to management in general and management of religious tertiary institutions were identified from the above process:

- The history and nature of private religious tertiary institutions;
- Characteristics of private religious tertiary institutions;
- Relationships among private religious tertiary institutions;
- Funding of private religious tertiary institutions;
- Accreditation of private religious tertiary institutions;
- Management structure of private religious tertiary institutions;
- Educational basic concepts of the different religious persuasions.

These categories were identified following the method of analysis mentioned in sections 3.2.3 and 3.2.6 as the qualitative research proceeded and sub-categories emerged during the study. Findings based on the categories above and additional sub-categories are presented in the following sections.

### **4.2.1 The History and Nature of Private Religious Tertiary Institutions**

The history and nature of private religious tertiary institutions are related topics which are presented under the following sub-topics:

- The nature of private religious tertiary institutions;
- The historical background of private religious tertiary institutions.

#### 4.2.1.1 *The Nature of Private Religious Tertiary Institutions*

It has already been highlighted in this study in sections 1.7 and 3.3.2 that the history of private religious tertiary institutions is not a long one and their number is still small. Before presenting data on their history and nature, a tabulation of the institutions studied is presented below in table 4.1. The names of the institutions and the informants were kept anonymous. Each institution was instead assigned a letter of the alphabet which represented its position in the sequence of the first interview conducted at the institution. The tabulation includes religious affiliation, duration of operation, number of students, number of teachers, accreditation status, and some notes which were unique and explanatory of the institutions.

Table 4.1 Presentation of Institutions Involved in the Study

<b>Institution</b>	<b>Religious affiliation</b>	<b>Duration of operation</b>	<b>Number of students</b>	<b>Number of teachers</b>	<b>Accreditation Status</b>	<b>Notes</b>
A	Seventh-day Adventist Church	15	160	16	Licensed by Government, and denominationally accredited	Licensed during the course of the study. Developed from secondary school to college then to university

Institution	Religious affiliation	Duration of operation	Number of students	Number of teachers	Accreditation Status	Notes
B	Anglican Church	5	80	-	-	Registered as an NGO All lecturers part-time
C	Islam	8	514	72	Chartered, (1990)	Chartered by an act of Government
D	Roman Catholic Church	4	193	40	Licensed by Government	Also Registered as a company
E	Non-Religious	4	701	-	Licensed by Government	Developed from a commercial college
F	Seventh-day Adventist Church	100 (39)	537	40	Chartered, (1994) and denominationally accredited	Developed from training school to affiliated college to university.
G	Non denominational	16	72	10	Licensed by Government, and accredited by ACTEA.	Non denominational but Christian; Only postgraduate programs
H	Seventh-day Adventist Church	17	900	60	Chartered, (1991) and denominationally accredited.	Developed from affiliated college to university
I	Multi-religious	21	14,000	90	Chartered	Multi-religious and Christian

Institution	Religious affiliation	Duration of operation	Number of students	Number of teachers	Accreditation Status	Notes
J	Africa Nazarene Church	3	200	6	Licensed by Government.	Mainly part-time lecturers
K	Roman Catholic Church	13	1211	67	Chartered, (1992)	Evolved from theological college to university; Has a large number of part time lecturers
L	United Methodist Church	5	557	30	Chartered, (1992)	A few part-time lecturers

(ACTEA Accrediting Council for Theological Education in Africa)

In addition to the above institutions which the researcher visited and where he held interviews, there were seven others which he contacted mainly through mail and they supplied some information by either sending certain official documents or responding to the questionnaire. Some of this information was useful in providing further insight into the study of the problem. All seven institutions were related to a religious organisation, some more strongly than others and at different levels of development and accreditation but none was chartered or licenced. Three of them were Theological Colleges offering degrees. The rest were developing into religiously affiliated universities.

The institutions which were visited were further categorised according to the countries in which they are based and their level of accreditation. The tabulation of this information as at the end of 1997 is given in the table 4.2 below. The table



includes the number of public universities per country for purposes of comparison.

Table 4.2 Levels of Accreditation of Public and Private Religious Tertiary Institutions by Country by end of 1997

Country	Public Institutions	Private Chartered Institutions	Private Recognised Institutions	Private Proposed Institutions
Kenya	6	5	9	18
Uganda	2	1	4	7
Zimbabwe	2	2	-	4

Notes:

- The public category included those institutions which are referred to as government institutions with either charters or university acts but fully supported by their governments.
- The chartered category included the institutions which are private, as defined in section 2.8, but have received official authority in form of charters to operate as universities.
- The recognised category included institutions with a licence or authority to operate from the Government.
- The proposed category included institutions that have submitted their applications as well as those which have not. Among both these groups there were those which were fairly developed and others which were as referred to by one respondent in a Ministry of Education as “very unlikely to be licenced”.

As may be observed from tables 4.1 and 4.2 above, private religious tertiary

institutions differ in nature and their history but generally most of them were established during the last ten years. Their differences include differences in religious affiliations, status of accreditation, number of students and staff, and kind of registration and recognition. Among the 12 institutions which formed the main sample, nine avowed to affiliation to a specific religious persuasion, one was non-religious, one was reported to be multi-religious and one was non-denominational acceding no allegiance to any specific religious persuasion.

Although the questionnaire was not the main research instrument, it yielded some useful data. Table 4.3 displays the data from the questionnaire, in summary form, which is referred to in the data presentation, discussion and synthesis. The rest of the data from the questionnaire, not included in the table, was only used to provide additional explanation and understanding of the respondents to the questionnaire and the institutions they represented. The following data are presented in the table: The letter representing the institution as used in section 4.2.1.1 is given in column one; column two has the number of questionnaires returned per institution; the respondent's opinions on the role to be played by mission in the appointment of the institution's chief executives as in question 21 in the questionnaire are given in column three; the respondents' attitudes to accepting government financial support from question 27 in the questionnaire are shown in column four; their opinions on the role of government in the operation of their institutions as in question 26 are given in column five; and an analysis of the respondents responses to the questions of purpose, strategy, values, behaviour standards and character as attributes of their institution's mission statement on pages seven and eight of the questionnaire are summarised in column six.



Institution	Questionnaires Returned	Opinion on Mission Statement Influence on Choice of Chief Executives					Opinion on Accepting State Funding			Opinion on Role of Government on Operation of Institution				Overall Rating of Institution's Mission Statement			
L	4	2	2				2	2			3	1			2	2	
Totals	30	16	12	2			15	11	4	1	21	4		6		10	10

Key to abbreviations and symbols used in table 4.3:

- C Critical
- VI Very Important
- I Important
- SI Somewhat Important
- NoI Not Important
- Y Yes
- N No
- O Other
- Co controlling

S	Supportive
P	Partnership
F	Providing Financial Support
NI	Non Interference
BA	Below Average
Av	Average
AA	Above Average

From table 4.3 it is evident that most of the respondents, 28 out of 30, consider the role of institutional mission in the choice of institutional management as either critical or very important. None had the opinion that it is only somewhat important or not important. This suggests that most of the respondents place value on the mission statement in management.

As regards government role and financing, although half of respondents were positive about receiving government grants, only one did not mind being directly controlled by the government. 21 out of the 30 respondents to this question indicated preference for supportive role only other than control. Some of these respondents included those who were positive as well as those who were negative about accepting government grants and the conditions under which the institutions would accept such funds differ from one institution to another.

As far as the quality of a mission statement is concerned five attributes - purpose, strategy, values, behaviour standards and character - are referred to by Campbell and Yeung (1990: 23- 37) as what determine whether the institution has a good mission statement. Purpose refers to the reason why the institution exists (Campbell & Yeung 1990: 24-27). It provides the people in the organisation with a justification for their work according to Campbell and Yeung (1990: 24). Strategy refers to the how the business (institution) achieves its purpose, or to finding a way to run the institution

against competitors (Campbell & Yeung 1990: 27). Values according to Campbell and Yeung (1990: 29), are beliefs of the organisation which have a moral basis and are often built on the personal values of a company's (institution's) senior management. Behaviour standards are guides to people's decision as to what to do and not do and ought to be included in the mission statement according to Campbell and Yeung (1990: 31). They should be the deciding factors when a decision has to be made between two rival options. Character, according to Campbell and Yeung (1990: 34, 35) refers to the writing style so as to make the mission statement readable.

In the questionnaire, appendix C2, as suggested by Campbell and Yeung (1990: 24) there are two questions under each of these attributes assigned marks ranging between 0 for "No" to the question, 1 for "To some extent" and 2 for "Yes". A total score minimum 0 and maximum 20 is possible. The worth mission statement was considered below average if its total score was below 13, average if its score was 14-16 and above average if the score was 17-20. This was an adaptation what is suggested by Campbell and Yeung (1990: 24) that good score is 15 and poor score is less than 10.

The responses to the overall rating of the institutions' goodness as shown in the table were diverse with almost equal rating between below average, average, and above average. This rating notwithstanding whether the mission statement of an institution is good or bad, the rationale and justification for establishing a private educational institution is occasionally determined from historical background and factors. The next section presents findings of the historical background of the institutions studied from the interviews and documents.

#### *4.2.1.2 Historical Background of Private Religious Tertiary Institutions*

With exception of the institution which had been in existence for over 100 years, the

rest were fairly recently established as degree granting institutions. Some have developed from theological training institutions or from denominationally operated secondary/ training schools as the respondent for institution E indicated *“The university was established from a college of commerce which started in 1969 to offer commercial courses for people who would not have qualified for entrance into public institutions of higher learning but had the desire to pursue commercial subjects...”*. The respondent for institution I indicated that *“...the university has been evolving over the years. We may say, however, that it started formerly in 1967 when research activities began”*. The accreditation report of this same institution by the Commission for Higher Education, the national accrediting body, in outlining its historical background, records that it was registered as a communications company at first with the following two major objectives: *“...to design strategies for penetrating cultures with the Gospel as given by Jesus the creator, and to train and assist African nationals and missionary personnel to utilise research and implement results from research”*.

Another respondent for institution K contended that the institution had *“...started in 1984 with Theology under ecclesiastical arrangements offering canonical degrees...”*.

Even the institution that had been in existence for 100 years had not started as a degree granting institution but had evolved over the years starting off with a training programme *“...for the development of workers for the church”*, then a teacher training programme, to a degree granting college. But the degrees were not recognised by the Government until the granting of the charter and the request for recognition took over 20 years to be approved because of the government policy which did not allow private universities. It then became an affiliated college and had eventually acquired the current status as a chartered university only three years previously.

Much as some of the institutions had desired to be autonomous degree granting

institutions earlier than when they were granted their charters, the prevailing policies in the countries that formed the territory of study did not permit the operation of private universities. In some instances proprietors of such institutions were advised and encouraged to affiliate with the national universities but that was not their desire as one Ministry of Education official intimated: “*We prefer them to be affiliated with ... but they do not want to follow our suggestion*”. The few which were affiliated with other institutions were affiliated to institutions outside of their countries but of their religious persuasion.

#### **4.2.2 The Characteristics of Private Religious Tertiary Institutions**

Data on the essential characteristics of private religious tertiary institutions are presented under the following sub-topics:

- Ownership;
- Kind of denominational relationships;
- Size of the institutions;
- Residential versus non-residential institutions.

##### *4.2.2.1 Ownership of Private Religious Tertiary Institutions*

Many of the institutions visited avowed to be owned by their founding denominational organisation. The respondent for institution A said “*We are owned by the ... Church including the property and we receive some funding... we are therefore fully Church owned*”. The respondent for institution B said “*This is a fully church owned university.*”. Yet another respondent for institution D intimated that “*... it is owned by the ... (name of the country) Episcopal Conference made up of the Bishops of... ( name of the church)*”. “*The Church owns the university. It is owned and run by the church*”, said the respondent for institution F. The respondent for institution K



said “*We are Church founded, Church maintained and Church ruled. The owners are all the Bishops of the Association of Member Episcopal Conference of Eastern Africa (AMECEA) countries.*”

A respondent for institution L explained that the institution “*falls under the ... Church*”. The church, on the other hand, has a number of agencies such as the Board of Global Ministries and the Board of Higher Education. The university “*falls directly under the Board of Higher Education*”.

Two institutions, I and E were not owned by any specific religious organisation. The respondent for institution I intimated that: “*We are totally independent. We are multi-religious*”. Institution E was non-religious simply a private university. Although this type of institution was not the focus of the study, it was close to being chartered. Therefore, the researcher visited it and conducted an interview in which some useful insights emerged. So it was included among the institutions that were studied and for which data was presented and discussed. This institution has a board of trustees who are “*the registered owners of the university*”, as reported by the respondent. The respondent further intimated that “*in fact one of the things that makes the institution stable is that there is no individual owner. The registered trustees are the corporate owners not looking for a salary or profit but geared for the promotion of education*”.

The respondent for institution J was, however, rather sceptical about Church maintenance saying that “*We could say that this is a Church institution, but it is very difficult to say we are maintained by the Church although those who support us are Church related. We are struggling to exist financially*”. The respondent went on to explain, however, that this is not because the Church is not interested in the institution but because of over-commitment with “*a lot of other institutions...*”.

The respondent for institution B explained that although financial support from the

church is small, it had donated the land on which the university could expand and develop in various ways for its survival.

Only one institution in Uganda which was among those which the researcher was not able to visit was reported by a Ministry of Education official as experiencing ownership wrangles between a church diocese and the individual who claimed to be the founder but had used the name of the church to begin the institution. As a result of these wrangles, the Ministry of Education official said, it could not be registered and was at the verge of collapse as the main church, to which it had originally purportedly been affiliated, had established another tertiary institution. Attempts to contact the institution were not successful.

Closely related to ownership is the kind of relationships that exist between the institutions and the founding church. Responses on these relationship are presented in the next section.

#### *4.2.2.2 Denominational Relationships of Private Religious Tertiary Institutions*

Guthrie (1992: 10) explicates what Pattilo and Mackenzie had postulated in the 1960's as the four different categories of denominational relationships of religious higher educational institutions as follows:

- the defender of faith colleges, in which all the affairs of the college are determined by a theistic world view;
- the non-affirming colleges, which although formerly related to a denomination, downplay their religious identity;
- the free Christian colleges, which do not control faith but view the relationship between religious faith and the liberal arts as complementary. The institution as a whole is guided by a religious world view;

- the Church-related universities, which are pluralistic by design with relationship to the church often limited to the inclusion of a divinity school as part of the larger institution.

With exception of the non-religious institution, some institutions indicated that they belonged primarily to the defender of faith category. This is intimated by the following statements of the respondent for institutions A that “*the curriculum we have developed puts God at the centre of everything that we do...*”, and that “*... to see that Islamisation of the community takes place.*” Respondent from institution C indicated that it belonged to the free religious category, “*there is inter-relationship between the Gospel commission and the mission which is to be able to tell people about God in our various ways of learning so that they can see the love of God in all these courses*”. Others belonged to the church related category. This last category is implied by the following statement by the respondent for institution D that “*the institution is meant to provide an academic education not to form persons as some expect of a religious institution.... It is therefore, an academic institution not a seminary for training priests*”.

None of the institutions indicated belonging to the non-affirming category which largely reflect the values of contemporary culture (Guthrie 1992: 10), although in practice some may have that tendency. Another characteristic perceived to be an identifying mark of a religious institution according to the literature is the size of the institution. Responses to this characteristic are presented in the next section.

#### 4.2.2.3 *Size of the Private Religious Tertiary Institutions*

The size of an educational institution is usually measured in terms of the number of students enrolled at a particular time. In terms of this definition the institutions studied were still generally small institutions compared to the public institutions in the

region. Only two of the institutions had an enrolment of more than 1000 students. Five others had enrolment of more than 500 students. The rest had less than 500 students with corresponding small numbers of lecturers ranging from six to 60. They were small institutions. *"We are just a small institution"*, one respondent retorted. Private religious institutions are therefore quite small compared to the already established public institutions in all cases. Even the institution that had an enrollment of over 1000 students was considered small. This is in comparison to the existing public institutions in the region which by the year 1992 were already ranging from 2,255 in Botswana to an average of 22,000 in Cote D'Ivoire, (Saint 1992: 9) and most of them had continued to grow in size from that time.

The small in size of the institutions may be attributed to their being newly established. They are apt to grow as the following experience of an institution that has been in existence for less than five years portrays:

We have just started a new year last week and our current enrolment is 557....Last year we had 307 students, so this is quite a big jump....We were expecting (planned for) about 525 but we had such a great demand so we stretched to accommodate extra students.

Unlike Latin America where private university enrolment accounted for 31 percent of total university student enrolment in 1970 (Saint 1992: 42), private universities were non-existent at that time. Since their inception their enrollment has remained insignificant and remained small. The demand for higher education, however, in the region is likely to continue to be exerted on the institutions regardless of their capacities. According to one ministry of education official, *"...the state universities were not able to meet the great demand of education in the country.... 11,000 students had qualified for university entrance in 1996 but Makerere university (the largest of the two state universities in Uganda) was able to take only 2,000 students"*.

There was disagreement among respondents concerning the view small size is a characteristic of religious institutions, but there was a general agreement that small size is more effective. The respondent for institution D contended that *“We, however, want to remain small. That is part of the characteristics of Christian institutions-knowing one another”*. On the other hand, the respondent for institution I argued that *“The important key is the staff not the number of students....Of course, the more students you have the more difficult it becomes hence we limit their numbers but if the staff are all involved with small groups the ripple effect of our world view spreads wide”*.

This concurs with Guthrie (1992: 5) who observed that in the United States “the majority of denominational institutions can be considered small colleges” when reporting on a study of 720 institutions. This was in comparison with the average size of the public institutions in the same country. It is to be noted that what is considered a small institution in the United States is still bigger when compared to that of the developing private tertiary institutions in the region under study. Their average number of students by 1991 was 1993 students (Guthrie 1992: 7).

#### 4.2.2.4 Residential Versus Non-Residential Private Religious Tertiary Institutions

According to De Jong (1992: 20), “to be a residential college means that most students reside on campus”. It is considered an essential characteristic of a church-related institution to be residential. This is because such institutions wish to “deliberately influence students’ lives” towards the normative development as a person, learner, worker, worshipper, citizen, neighbour, family member (Saint 1992: 21).

In the United States of America, this characteristic is challenged by the increasing enrolment of non-residential students (Saint 1992: 21). In the institutions studied the

situation was ambivalent. Living space and facilities were as indicated by the respondent for institution L, who said that the number of students they could take in was *“limited by the facilities”*, although they also wished to remain small. Another one said that *“housing is not sufficient so we don’t house all of them”*. The respondent for institution K indicated that the university was basically non-residential *“although we have a few residential students but the university is mainly an off campus university”*. In this institution the limited residences at this university were reserved *“for priests, lay women and sisters”*. The rest were mainly residential universities, a number of them situated far from cities and towns where public residence is easier to obtain. One, however, which was situated in a capital city, was both residential as well as non-residential.

#### **4.2.3 Relationships with Different Sectors of the Society**

In Section 4.2.2.2 denominational relationships of private religious tertiary institutions were presented. These had to do more with the relationships with the founding religious bodies which the institutions were affiliated to. These institutions, however, have other relationships which may be categorised as follows:

- relationships within the institutions
- relationships with the community
- relationships with the government
- relationships with public institutions
- relationships with other private tertiary institutions.

Brief information was gathered and observed with regard to each of these relationships and is presented below in the following sections.

#### 4.2.3.1 *Relationships within the Institutions*

A number of the institutions studied indicated a desire to develop an atmosphere of interaction as stated by the respondent for institution A : *“The university seeks to provide a physical environment and appropriate academic and student support systems to facilitate the variety of human interactions and relationships essential for learning...”*. Another intimated: *“Firstly, we try to have a total atmosphere that is Christian, by having Christian administrators, faculty and students.... So by having the majority as Christians we keep the atmosphere Christian”*. This could be observed in many of the relationships among the people on the campus. This leads to a community, which according to Holmes (1989: 79) *“...arises from the social nature of those whose common stake in life and common values unite them in a common task”*.

Although not all institutions studied made direct statements about their internal relationships, observation indicated that there was a strong desire to maintain good intra-relationships among the internal communities. At one institution informal discussion with students revealed that the students appreciated this kind of campus culture by contending that *“we live like a community who care about each other here”*.

This, however, is not always so. Some instances of tension and conflict had occurred on some of the campuses studied such as the one reported in one of the newspapers that *“...one would expect the students and the administration to sit at a round table and solve their differences in a spirit of ‘brethren’*. But stand-offs between the two parties inevitably end up with students being locked out”. This reporter was writing about a situation that had developed at one of the institutions studied whereby the students, after failing to abide by certain regulations of the university, had been given the option of leaving the campus and many had done. Further tensions developed but the

administration said that they had handled the situation in an appropriate Christian manner adding that “...*being a Christian university puts more responsibility upon its managers to help the students become loyal citizens*”. Generally, however, the institutions desired and endeavoured to maintain sound relationships not only within but with the surrounding community as well.

#### 4.2.3.2 *Relationships with the Community*

The community may be interpreted as the larger society in the area surrounding the university in which the institution is situated. It, however, is usually limited to the surrounding community in which the influence of the university may easily be felt.

Although not many respondents talked about their relationships with the community directly, one respondent mentioned that it was one of the primary responsibilities of the institution “...*to nurture the qualities of service both to the Church and the community*”. Another also mentioned that “*public service*” was imbedded in the university creed seeking “...*out of Christian love and concern to serve mankind creatively, responsibly and humanely...*”. Public service orientation is referred to by J. Davies (in Stott & Walker 1992: 51, 52) as the institution’s relationship with the community. The translation of this desire in the life of the institutions was again observed in the non-hostile but generally supportive relationship with most of the institutions’ communities.

#### 4.2.3.3 *Relationships with the Government*

Relationships with the governments are crucial because of the very definition of private institutions and the responsibility to of governments control educational standards. University-state relations were identified by one vice chancellor as the most critical problem facing African public universities in 1991 (Saint 1992: 32). This



tension, as far as the public universities were concerned, originates from governments' perception of the university community as a frequent locus of criticism and political opposition, the increased involvement of governments in university affairs, and the inability of governments to provide for the financial needs of universities on a suitable basis (Saint 1992: 32). The latter source of tension is similar the challenge facing higher education elsewhere as the declining support from the Federal Government in the United States Gillian (1984: 87).

Relations of private religious tertiary institutions with governments take a different form since these institutions expect little interference with government. The relationship is, however, rather intricate in that it is the governments which give authority for these institutions to operate and they are responsible for the education system of their nations (Williams 1989: 3). In the report of the Commission for the Establishment of a Second University in Zimbabwe the following reasons were advanced in support of government is primary responsibility and control for higher education (Williams 1989: 56):

- Government taking responsibility reflects the importance of universities and colleges as institutions at the apex of the national education system, that give intellectual leadership and help define the culture and identity of the nation;
- Higher education institutions (in existence and proposed) are crucial in the development of high level skills and in the generation of useful knowledge. This function can not be left to a series of accidental and uncoordinated decisions by private interests;
- Government involvement provides a guarantee of the standards and the quality of education provided; and
- Higher education is costly and has to be subsidised by government if it is to be accessible to more than a select few.

The establishment of the National Council for Higher Education in Zimbabwe was recommended by the same commission in order to take control of higher education matters on behalf of the government because of the above reasons since there were already applications by private interests to establish or have their universities recognised (Williams 1989: iii, 56). The Government policy, however, was that such institutions would have to be affiliated to the University of Zimbabwe (Williams 1989: 58). That policy appeared to have changed by the time of the study. Section 19 (2) of the National Council for Higher Education Act states that, (Government of Zimbabwe 1990: 423)

Upon publication of a proclamation in terms of section (1), the university or university college concerned shall be established as a body corporate capable of suing and being sued in its corporate name and, subject to its charter, and this Act, of performing all acts that a body corporate may by law perform.

Charters of individual universities make provision for governance, staffing and staff qualifications and the senate which is responsible for academic affairs of the universities. Similar rationale of government responsibility and control was the basis for the establishment of corresponding bodies referred to in section 2.5.2 as the Commission for Higher Education and the proposed National Council for Higher Education to control the establishment of private higher education in Kenya and Uganda respectively.

The following were responses from the respondents representing the institutions visited in the present study as far as relationships between them and governments are concerned.

One respondent for institution A said:

At this time it (the relationship) is very friendly. No hitch. Government has not defined the status of private universities.... However, the President has been

very supportive. The Minister of Education is very supportive as well.... So far the Government encourages privatisation. Apart from safeguarding standards the government does not interfere.

The same respondent argued that the Government supported religious institutions because of their emphasis on morals which was the interest of the Government since public institutions were, according to the respondent, of a lower moral standard. Another respondent for institution B agreed stating that *“The President appreciates the role of private university education and is willing to start giving grants to such universities”*. The respondent for institution C simply said that the relationships were *“cordial”*, but was quick to add that *“they (the Government) don’t fund us and they don’t control us”*. It was also intimated by the respondent for institution D that the President’s support for private religious institutions was because *“...these institutions are augmenting the efforts of the Government”* to provide education to the many people in need of it.

Another respondent for institution F located in Zimbabwe said that:

the government sets parameters in which the university operates, it granted the charter, but it does not interfere with the details. The charter is ours.... The Government ensures that quality and basic human rights are not violated and it monitors to see that we are operating within those parameters.... So Government is overseer but the charter is ours. It is not a government charter.

Even in giving grants to students of this institution the respondent indicated that the recipients are selected by the university and entrance is not dictated by Government, saying, however, that *“It is like a parent would pay fees for a student here...”*. *“The charter provides for the people to come to the council from outside of the constituency of the university including representation from public sector, from the Ministry of Education, and from the Government.... This is sufficient Government involvement”*. Besides this *“...we basically operate autonomously”*.

This respondent's remarks shows that the respondent understands and prefers Government's role to be overseer, with minimal interference in the running of the university. Two other respondents representing institutions K and L described their relationship with Government as given in their charters saying that "*...it is described in the charter*" and "*...our relationship with the Government is that we have a charter which establishes us as an institution giving powers to the institution. Therefore, we are governed by that charter and if there are any changes we bring them to...which is responsible for and controls such matters*". This differs from Cooper and Gargan's (1996: 159) observation that in the United States one of the adversaries faced by private parochial schools was the Government's desire to control their curriculum, staff qualifications and results although they did not fund the schools.

The rest of the institutions described their relationships in terms of fulfilling the requirements of the Governments through the bodies that control such institutions, such as submitting all the papers required for obtaining registration and subsequent accreditation and providing yearly reports as required, "*we report to them (the government) on a yearly basis.... This is a government requirement. They don't control what takes place here, however*".

A respondent for institution I in Kenya talked of what may be termed a reciprocal relationship with the Government saying that the Government "*inspects and supervises the university and approves new programs*", but also mentioning that the institution is constantly in touch with the permanent Secretary in the Ministry of Education and "*participating in various government committees*". The respondent summarised by saying that "*we enjoy cordial relationships*".

The above responses indicate that the institutions studied have not hitherto experienced adversarial relationships with governments. Dehne (1989: 4) argues that

the threat to the existence of private schools comes from within when schools neglect their inherent advantages rather than from the government's attempt to price them out of the market.

#### 4.2.3.4 Relationships with Public Institutions

Public institutions are also referred to as state institutions or government institutions. Section 4.2.3.3 has already indicated that the public tertiary institutions are experiencing various tensions with their respective governments. According to Williams (1989: 56), however, they are at the apex of a nation's education system. A Ministry of Education official in Uganda intimated that it would be the desire of the government to have private universities affiliated to government public ones but the proprietors of the private universities do not want this as this remark shows, "*We prefer them to be affiliated with...but they do not want to be affiliated with any other public university*". With exception of one institution that expressed the desire to be affiliated to a public university, the rest confirmed the Ministry of Education's official statement by wishing to be autonomous and complementary.

One respondent representing institution B alluded to some rivalry between the private institutions and the public universities. The public universities were cited as by initiating the same programmes and systems such as courses similar to those established by private institutions but which they did not offer before, evening classes and the semester system. This tuition had been originally introduced by the private universities in some countries. The respondent said: "*As soon as we start a course they too do the same such as the Bachelor of Business Administration course, the semester system and evening classes which we were first to start and they (the public university) also did*". There is still a feeling that "*...apart from...(the oldest state university) no other institution can be a university*".

Almost all institutions studied assented to utilising the services of lecturers from the already established public universities as either adjunct or part-time lecturers as implied in the following statement by one of the respondents: *“All our lecturers at the moment are part-time coming from...(the nearest state university) and other institutions of higher education around”*.

A respondent for institution E in Uganda also avowed that the public institutions were the major wellspring of their staff development programme. They were more cost effective since most of their staff remained at work while upgrading and the institution only provided transportation as support for their academic advancement and upgrading.

The relationship with the public universities has both positive and negative side. On one hand public institutions provide support in the form of part-time lecturers and staff development opportunities. On the other hand there are feelings of apprehension on the part of private institutions arising from competition between the two types of institutions.

#### *4.2.3.5 Relationships with Other Private Tertiary Institutions*

As the phenomenon of private tertiary institutions is a new one in the region under study, there were no formally established relationships among the institutions as yet in any of the three countries included in the study. The following were some of the responses to this issue.

A respondent for institution A said that

Most of us are very new. We are struggling to establish linkages as an initiative of...(one of the Vice Chancellors of a newly established private university) which we all support. We have also been invited by the Minister of Education

who stressed high standards and advised us to form an association to discuss common issues and enhance relationships. This is still in the making.

Another respondent indicated that hitherto they had been meeting when they have problems but agreed with the last comment, saying *“recently we have began thinking about forming an association but we are still in the infancy stage...we only meet when we have a common problem to resolve”*. Another respondent representing institution E also agreed with the aforementioned respondents referring to the association as a forum and described the relations as *“...quite good. We recently hosted a meeting here in which we were trying to create a forum of private universities”*.

In another country the relationship realised through membership to the national body that controls the affairs of higher education, other national and regional higher education associations and by invitation to various universities functions, *“we invite each other for various university functions such as graduations”*.

A respondent for institution G mentioned a relationship realised through a fellowship among theological colleges which organises some *“exchange of lectureships sports and social activities”*. The respondent also talked of an inter-library arrangement with both private and public institutions.

Another respondent representing institution H explained the relationship in terms of accepting transfer students from other institutions by stating: *“We can only take in such students from other chartered institutions. Such students would be taken at the academic level they have achieved”*. The same respondent said that they also relate to both private as well as public universities through *“...exchange of lecturers on adjunct basis as we try to get our own full-time lecturers, and attending professional meetings such as seminars for our lecturers”*.

Relationships among these institutions, although not yet formally established are

being sought in various ways and there was no evidence of suspicion or rivalry among them.

#### **4.2.4 Funding of Private Religious Tertiary Institutions**

Private institutions as alternative sources of funding higher education are developing at a time when most African governments are facing economic hardships making it difficult to adequately fund higher education (Hinchliffe 1987: 97, 98); Saint 1992: 42). The same alternative, however, at times claims a right to public funding (Cooper and Gargan 1996: 174), despite the very definition of private education is that which is not funded by public funds.

Besides the controversy that arises in connection with government funding of private education, there are other issues having to do with internal funding of private institutions in comparable economic conditions. A Ministry of Education official mentioned that funding is one of the requirements looked at when the authorities are considering giving authorisation to operate a university. Data received on this issue is presented and discussed under the following headings:

- Sources of institutional funding.
- Funding from government.

##### *4.2.4.1 Sources of Institutional Funding*

All respondents referred to students' fees as a major source of funding for their institutions. In most cases it was the main source of funding. Another source of funding cited was the religious body that operated the institutions. It provides activities and programmes such as church sponsorship of overseas personnel as respondent for institution A pointed out: "*The Church also sponsors financially some*



*overseas personnel*". Another stated: *"The Church is not very rich. However, the university gets some levy from every child in church schools in... (diocese served by the university)"*. This source of funding was small *"...less than 5%"* of requirement. However, additional funding from the church was in terms of tangible items such as land, *"...if you value the other assets such as buildings, land...donated for further expansion it is more than one can put in monetary terms"*. Another respondent from institution B also agreed with the former that they too received some funding *"...from the dioceses"*, and another from institution J said: *"...donations came from Church-related people"*.

The respondent for institution L stated that the institution had only begun to charge fees for the first time the year prior to the study, having hitherto given all the students scholarships *"...since they were very few and we had enough funds"*. This rather unique plan to provide scholarships was to continue but under a different arrangement. The respondent added: *"All first year students will not be given any scholarships at all. This would enable us to assess the real needs and assist those who are really needy and struggling"*.

Other sources of funding included donations in monetary form as well as in kind in the form of vehicles and land to some institutions, appropriations from Church organisations such as *"...contributions from the Association of Member Episcopal Conference of East Africa (AMECEA) and the Holy See"* as cited by one of the respondents for institution K.

Another respondent representing institution D said that *"...students fees only fund 70-90% of operation and donations assist in terms of visiting professors and fund 90% of capital development"*. The difference was funded by internal revenues. This institution had a school farm producing revenue and it had recently acquired a donation to expand the farm and make it more viable. This expansion had already

began.

The respondent who represented institution L, which had just started charging fees, indicated that the institution had two main sources of funding. The first one was *"...an approved plan of funding to produce and give the university 10 million dollars through what was referred to as church apportionment done by assessing all the churches and drawing a plan by which all can support the university (with a certain amount) every four years"*. The respondent added that *"...with this fund we have done very well although we don't get everything, we get about 90%"*. Another source was a donation from World Service Special Gifts to match the same amount raised by the first method which was also approved by the world-wide General Conference of that Church. However, the respondent said that this had not worked well and had only yielded about 50% of the expected amount, part of which the institution has placed in endowment in anticipation of a time when according to the respondent *"...we shall have to depend on ourselves"*.

Two respondents, having expressed the inadequacy of student fees in meeting the development needs of the universities, said they would gladly welcome government funding which according to the respondent for institution E *"...would ease our financial tightness"*.

Caught between the desire to establish universities and the dilemma of charging substantial amounts in student fees, some of the institutions may have no alternative but to claim right to government subsidies. This in itself is a contentious issue as the following quotation from a newspaper portrays.

University education is a necessity in every country, especially in African states where there are still very few university graduates. However, it was not smooth-sailing for those who have gone through university education. Many intelligent young people from poor families have found it difficult to attain

university education because of lack of school fees. Some have not been so lucky and the struggle for fees is an ongoing one every year. Financial constraints are one of the main problems facing students today (Dhliwayo 1997: 8).

Additional excerpts from newspapers on the subject of funding from government are appended at the end of this thesis in appendix E. They indicate that the subject of funding private education and all education generally is a very controversial one particularly as it relates to student fees in unstable economies.

#### *4.2.4.2 Funds from Government*

As already indicated in the preceding section a few of the respondents were eager to receive funding from government in order to augment their budgets. A number of other respondents were not as direct in wishing to accept such funds. Nevertheless, there were conditions cited under which many of the respondents would accept funding from government.

In two countries in which the institutions under study were situated the governments had started giving grants in form of loans to the students in private universities as indicated in the following quotation from one newspaper in Zimbabwe (Herald Correspondent, December 7, 1995: 4), appendix E:

The Government would give loans and grants to local students studying at private universities in the country beginning next year. At present, the Government is only assisting those at...(public universities) and at universities in South Africa.

A few months after the above article appeared in the paper the Minister of Higher Education in that country was quoted as having announced that the government would give loans and grants to students studying at private universities in the country.

Although this was a lengthy procedure, according to respondents for institutions F and L, it had been effected. However, it was in its early stages and needed to be perfected.

The giving of grants and loans to students in other countries yet leaving out those students studying in private institutions, which had been granted charters by the same government was not easy to comprehend.

The following responses portray the prevailing situation at the time of the study. All respondents said they were currently receiving no direct institutional grants from government although some acquiesced to receiving some assistance in forms other than monetary. One mentioned that the Government had given the *"...site which was formerly a government school, they (the Government) have given us three vehicles over three years and an additional three acres of land"*. Another one said: *"The Government has given us a lorry..."*. Yet another mentioned that *"...the land was donated by government without any strings attached including the cows that were on the farm"*.

Regarding grants in form of student loans from Government, all respondents receiving these grants assented to this. *"it is like a parent would pay fees for a student here"*. These grants do not come with any strings attached or specific conditions resulting in to government control as the same respondent points out *"...there is no saying that you do this or that" adding that "these students are selected by...(the institution)"*.

On the question of whether the institutions would accept direct funding from government, besides the two who indicated that their institutions would be desirous of doing so others said they would if there were no strings attached. The respondent for institution G said: *"Of course as accrediting authority they have their own terms but*

*we wouldn't like them to interfere with our autonomy*". Another one representing institution I said that they *"would examine those funds to see if there are no strings attached. As long as they have no strings attached we would have no problem"*. In this regard one said: *"...as long as there are no conditions attached"*, adding that *"...the best kind of grants would be through student scholarships"*. Another respondent representing institution A, in agreement with the others, added: *"Being a Church institution we do not want the Government to take over to the extent that we lose our objectives. As a Church we are not prepared to compromise our objectives"*. The respondent for Institution L said: *"It would depend on the conditions. Education is the responsibility of the Government, the Church is only joining hands in mutual support of each other"*.

One of the respondent for institution K, however, put the position of the Government sponsoring the institution as follows: *"We do not want them (the grants)...The Catholic Church wants to be independent. Government funds come with a lot of strings attached"*.

Responses from the questionnaire on the question of government involvement was summarised as follows: 21 of the 30 respondents said the role of government should be supportive, eight marked non-interference, four partnership, one controlling and none marked providing financial support, see table 4.3. Two respondents marked both non-interference and supportive. While none marked providing financial support, government's role being support would as well imply some financial support since thirteen of those who were in favour of a supportive role of government also answered 'Yes' to receiving financial support from government but apparently not directly and without controlling powers. Two of those who were in favour of non-interference were also in favour of accepting financial support from government.

If grants are to be given to private schools, the question remains as how private

education serves as an alternative provision of education financially. Cooper and Gargan (1997: 173) identify the area of financing as one which makes the boundaries between private and public obscure. On the other hand, however, without such assistance operation of private universities would be very difficult having to compete with “free” or state subsidised education according to T. O. Eisemon (in Saint 1992: 43) and Cooper and Gargan (1997: 160).

On the other hand, Gross (1987: 27) writing about funding in general, states that “...nothing can obscure an organisation’s purpose more quickly than the funding chase. This happens when a group stops looking at what its mission is and it need to do and starts focussing instead on what the funders seem to be interested in”. Instead, Davies (1985: 81) argues that funding should be in accordance with institutions’ mission statements which themselves should be subject of periodic review.

#### *4.2.4.3 Accountability*

Issues related to funding are occasionally turbulent and volatile in cases of public institutions (Saint 1992: 41) and sources of mistrust when there is little or no accountability and transparency. On the other hand, Sanyal *et al.* (1996: 2) states that in most countries, as public sector resources become more and more constrained, university resources decrease while at the same time demand for accountability increases. In discussing accountability and autonomy of higher educational institutions, Saint (1992: 39) suggests participation in strategic planning and mission development involving where necessary those who may provide the funding. The researcher thinks participation by the government should not be mandatory in cases of private institutions but providing information to all and making the mission known is crucial in issues concerning funding.

Other suggestions to ensure accountability include regular reports to the management

beginning with the on site management where departures from the strategic plans may be discussed in readiness for presentation to the governing boards of the institutions. Some of the institutions studied, F and H, were doing this and were considering utilising internal auditors, such as the case in business enterprises, in addition to the occasional audits by external auditors.

Because of similar suspicions about funding at the lower levels of education where it is perceived that some might have established private schools for purposes of enriching themselves, it would be advisable that proprietors of private religious institutions operate in a transparent manner to remove any traces of suspicion. This could be achieved by providing financial information about income and expenditure to both staff and students on a regular basis. Paying of fees at higher levels of education is still a new idea in the countries studied and is still viewed with contempt despite its introduction in the public institutions. It, therefore, calls for a higher degree of accountability and transparency on the part of those managing the funds to those who pay them to avoid contention.

#### **4.2.5 Accreditation of Private Religious Tertiary Institutions**

The process of accreditation refers to the process of recognising an educational institution as maintaining standards that qualify the graduates for admission to higher or more specialised institutions or for professional practice according to the Webster's New Collegiate Dictionary (Merriam-Webster 1980: 8). This is a relatively new process in the region that has probably come with the move to have private institutions established. Universities, which were all state institutions, were hitherto established by Act of National Parliament (Saint 1992: 72) and once established they operated more or less autonomously with only internal checks and the use of what is referred to as external examiners. However, with the emergence of non-government universities and the recognition of the need for co-ordination and a measure of control

of such institutions accreditation was proposed as the following recommendations of the commission to inquire into the establishment of a second university in Zimbabwe states (Williams 1989: 60):

1. Non-government university institutions primarily serving Zimbabwe students should be affiliated to or associated with one of the national universities of Zimbabwe or accredited to a validating body within the country.
2. Non-government organisations with internationally based boards of management and international recruitment of students that wish to establish university institutions in Zimbabwe should be accredited to a validating board in Zimbabwe and should be required to conform with certain guidelines to safeguard Zimbabwe's interests. Such institutions should then be established under appropriate legislation.

The same commission (Williams 1989: 104) recommended the establishment of a National Commission for Higher Education, which, at its inception, was named the National Council for Higher Education (Government of Zimbabwe 1990: 416). One of the major functions and powers of the council is "...to receive and consider applications for the establishment of private universities and university colleges"(Government of Zimbabwe 1990: 416).

Likewise, in Kenya, similar for reasons according to an official in the Ministry of Education, the Commission for Higher Education was established. One of its roles is "to accredit universities" (Commission for Higher Education 1990: ii).

In a more recent development also prompted by the same reasons, according to an official in the Ministry of Education in Uganda following the nomenclature used in Zimbabwe, a National Council for Higher Education Act as well as a Universities Act have "...been drafted and approved by the Ministry of Education top management". By the time of the study, however, the two Acts had not yet been presented to the Cabinet and the Parliament for final approval and subsequent implementation as



required by law in Uganda. One of the functions of the proposed National Council for Higher Education is “...to accredit universities and register other tertiary institutions” (Government of Uganda 1997: 9).

The succeeding presentation and discussion indicates that the idea of accrediting of educational institutions is a rather recent development in the countries under study. Data collected from interviews and document analysis on this subject is presented under the following sub-topics:

- Levels of government recognition of private institutions
- Procedure for recognition of private institutions
- External accreditation and affiliation of private institutions.

#### *4.2.5.1 Levels of Government Recognition of Private Institutions*

Table 4.2 shows that generally, besides public institutions, there are three classes of private institutions representing levels at which these institutions are in the process of being recognised by governments. These levels are the proposed ones; the recognised ones, also referred to as licenced or with interim authority to operate; and the chartered ones. According to a Ministry of Education Official among the proposed ones there are those “...which are in the process and have submitted their application papers”, and those “...which are still a long way and are not likely to be licenced soon”. Recognised ones are those which have had their papers looked at, inspected by a team of professionals and given interim authority to operate.

Responses from the respondents also indicate the various levels at which the institutions are. The respondent for institution A argued that the delay in their recognition was because hitherto the Ministry of Education had not developed guidelines to “...regulate private universities”. A few, in such circumstances, were

registered as Non Government Organisations (NGO) in order to be able to operate, as indicated by a respondent for institution D: “We are only registered with the NGO Board”.

#### *4.2.5.2 Procedures for Recognition of Private Institutions*

The process of recognition of private institutions follows a series of steps in all the three countries studied which are meant to ensure and maintain high standards and quality of education.

The procedure which is followed, is outlined in Acts that set up the national bodies entrusted with the responsibility of accrediting universities. The procedure according to the Government of Zimbabwe (1990: 422) includes the following steps:

- Application to the council by whoever wishes to establish a private university, which should include a draft charter of the proposed university, such information as may be prescribed or as may be required by the council (the National Council for Higher Education), and the prescribed fee
- The council having considered the application and conducting an inquiry, makes observations, and such investigation as it may consider necessary after which it submits the application together with the council’s recommendation to the Minister
- The Minister submits the application and council’s recommendation together with any further recommendations he may wish to make to the president, or may require the council to conduct further inquiry or make further investigation in the matter
- The president upon receiving the application and if he considers the establishment of the university as a furtherance of higher education in the country, grants the institution a charter which is then promulgated into law and

published in the national gazette as a university.

Similar procedure is followed in Kenya and is proposed for Uganda. However, more details are required, both Kenya and in the proposed procedure for Uganda, to accompany the application including the proposed name, location, and academic character of the university; the aims and objectives consistent with university education in the country; the form of governance; an outline of the academic programme; the academic resources including finances, staff, library services and equipment; and a timetable indicating steps in the next three years towards the realisation of aims and objectives of the university (Government of Kenya 1989: 92, 93). The procedures then have a provision for the issue of an Interim Authority which authorises the proprietor to officially open the institution and continue the development of the physical facilities and assembling the academic resources. The commission continues to evaluate and supervise the performance of the institution when under interim authority.

A university which is a holder of a certificate of registration or letter of interim authority may then apply for accreditation upon satisfactory progress and development. It is with this application that the draft charter is submitted along with other requirements which are more specific this time including a list and academic qualifications of members of staff; a list of the total number of students; a statement of the size and quality of the library and equipment for each program being and to be offered; a statement of the financial resources; and an inventory of the physical facilities including land (Government of Kenya 1989: 96, 97).

The commission upon receipt of the application and while considering it may appoint an inspection committee to "...ascertain the veracity of or otherwise the particulars submitted"; to "...make inquiry into the general academic, administrative and social affairs of the university"; and to "...make such other investigations of relevance to the

application...” (Government of Kenya 1989: 97). The Commission when satisfied by their observations recommends to the Minister for the institution to be accredited.

In Uganda, according to the draft Act (Ministry of Education 1996: 44-46), the same steps are to be followed only that instead of the Commission for Higher Education it is the National Council for Higher Education to which applications are addressed.

The procedure of accreditation, which is still new to proprietors of private institutions was perceived to some as too lengthy. Yet others had gone through the process before it was well outlined, a phenomenon that can lead to discord among those to whom it was to be applied strictly. It is possible that the interim licence is misinterpreted to mean final accreditation as implied by the following response:

When we applied they (the Government) sent us an application form for registration which had a number of areas including finances and recruitment of students and staff. Having sent this form back they sent an independent team of university lecturers to look at us and our programmes. It is this team that sent recommendation for accreditation.

The letter sent, however, reads, in part as follows: “This is to certify that ...university is licenced to operate as a university. We do hope that you will fulfil the objectives as stated in your mission statement”. While what was issued was a licence, this respondent referred to it as accreditation.

Another respondent representing institution J, however, understood the difference between an interim authority and a charter and responded as follows: “*We started to operate with an interim authority...There is what we call a charter which we don't have as yet*”.

Another difference in the functions of the bodies that are charged with the responsibility of regulating tertiary education is that in Zimbabwe the National

Council for Higher Education is responsible only for private tertiary institutions while in Kenya the Commission for Higher Education and in Uganda the proposed National Council for Higher Education are and will be responsible for all tertiary education including both public and private tertiary institutions. Zimbabwe was, however, also contemplating doing likewise as indicated in the following minute of the National Council for Higher Education (National Council for Higher Education 1997: 3):

It was pointed out to the Council that South Africa has one Act which governs Higher Education with special references to various universities. Zimbabwe could emulate South Africa so that, in due course, she has one Act which governs all her universities.

The desire, therefore, is to have all tertiary institutions under one Act that controls all their affairs for both the public and private degree and non-degree granting institutions.

#### *4.2.5.3 External Accreditation and Affiliation of Private Universities*

Besides accreditation by government four respondents said that their institutions are also accredited by other accrediting bodies based outside their countries. One of the bodies referred to is an international body that is responsible to accredit all institutions operated by that denomination based at the headquarters of that denomination, while the other is a regional body that is responsible for accrediting theological education in Africa. Three of the respondents argued, however, that they needed the national government accreditation for academic recognition of the degrees and other qualifications they award to their students in the country. One intimated that they did not need the national government accreditation since they were already accredited by the regional accreditation. They were only seeking that accreditation because it was a government requirement.

The other institutions were not accredited by any other accrediting body and none at

the time of study was affiliated to any other institution although some had made attempts to affiliate with some other institutions and others had linkages with others not in the form of affiliation. One of these linkage was with another institution under study as a respondent representing Institution B, an institution that was not yet accredited by government, indicated: *“We have a relationship with...(another private university with similar religious persuasion but already chartered) being developed. So far there have been visitations from both sides to develop the relationship. This relationship could develop into an affiliation arrangement”*. Another respondent representing the same institution that was trying to affiliate with another institution abroad said: *“We are cultivating one affiliation but we have not yet succeeded. We are discussing with...(an institution abroad) and others but we have not yet concretised our discussions”*.

Two respondents disclosed that their institutions had been affiliated with others abroad before receiving their own charters. A respondent for institution I explained that: *“Before the charter we were affiliated to...(a private university of similar persuasion in the United States of America) but now we are only linked to the same institutions and the Christian Colleges Consortium for purposes of staff and student exchanges”*. Such affiliations were phased out after the institutions received their own charters because they were *“...expensive to sustain”*, as the respondent representing institution F intimated.

Such accreditations and affiliations, in the opinion of the researcher, assist in the international recognition of the institutions and should not be discouraged where they exist.

#### **4.2.6 Management Structure of Private Religious Tertiary Institutions**

Saint (1992: 71) contends that university management (governance) structures in

Africa are generally derived from institutional models of higher education established by pre-independence administrators and although some modifications were attempted, the general structure remained very much similar. The concept “structures of private tertiary institutions” is used here to refer to form, organisation, order, pattern and system of management of private tertiary institutions beginning from the national level to the institution level including the structure within the institution. Data related to this category, collected through interviews, document analysis and observation are presented under the following sub-topics.

- Management at the government level
- Management by the foundation body
- University Councils or Governing Boards
- Management at institutional level.

Some of the topics may appear to be interrelated because of the relational nature of the different levels of management.

#### *4.2.6.1 Management at the Government Level*

Ministries of Education are responsible for general provision and management of education in all three countries that formed the population of the current study with powers entrusted them by the governments. This is the ultimate authority of management as far as education is concerned, including private education, in the countries under study. As was alluded to in sections 2.6.1, 2.6.2 and 2.6.3 management of private education at the lower as well as higher levels of education has had little mention in the management structures of the Ministry. This might have been so because the governments had accepted full responsibility for the provision of education not expecting the development of private education to become necessary. As this became increasingly difficult they decided to make provision in very limited

terms in the various education Acts. As for private tertiary education provision for their management at macro (government) level has been discussed in section 4.2.5.1 and 4.2.5.2. There it was also discovered that it was still a new provision which had arisen as a result of the desire to establish private tertiary institutions, an urge that could not be resisted because of the great demand for education generally. As a result, bodies have been established to supervise and advise on the development of tertiary private education. A Ministry of Education official stated that the Ministry would not stop those who want to establish universities. He said: *“What the Ministry of Education requires is fulfilment of minimum requirements. This is because it realises that state universities are not able to meet the great demand for education in the country”*.

The establishment of the Commission for Higher Education in Kenya, the proposed National Council for Higher Education in Uganda and the corresponding University Acts, and the National Council for Higher Education in Zimbabwe (sections 2.5.2, 2.6.1, 2.6.2, 2.6.3, 3.3.6, and 4.2.5.2) are steps taken towards streamlining the management of, not only private tertiary education, but all tertiary education. The statutes for these bodies stipulate the nature of governance they propose for the institutions which, in essence, are replicas of the national structures patterned after those passed down to the governments at the inception of university education. The government, for example, has representatives on the university councils of private universities in Uganda and Zimbabwe. These are appointed in consultation with the responsible authorities. The statutes also stipulate the rights and obligations of the institutions. One difference between the public and private universities is that the chief executive(s) of private universities is (are) not appointed by the government or head of state as is the case for most public universities, a practice that has come under attack by several authors on the subject. Saint (1992: 73) postulates that a major source of friction in universities is the fact that senior university administrators are appointed by government and seem to be more accountable to the state than to the



universities.

Two factors - only appointing representatives to the council and not appointing the chief executives - tend to make private institutions more autonomous from government as the respondent for institution F intimated “...we operate *autonomously*”. The ministries of education still, however, are held accountable for the education of the nation as the Minister of Education in Zimbabwe maintained “*I have to account to parliament for what goes on in the education sector. This is particularly so because we provide grants to the students even in private institutions*”.

In summary private religious educational institutions operate in what may be referred to as a dual governance system particularly on the macro level. They are governed on one hand by the government while on the other hand by their founding religious bodies. This dual governance system should be expected to have some effect on the nature of management at the macro as well as the micro levels.

As already seen, all educational undertakings are managed at various levels the first of which is the macro level referring to management at the national level, the middle level usually provincial or district level sometimes referred to as meso level, and the institutional level referred to as the micro level (Van Wyk 1994: 5).

The macro level mainly deals with general educational management policies which would normally affect all educational institutions within a country. Such policies would not usually discriminate between different proprietors or founding bodies of the different institutions. As far as private institutions are concerned, the ministries of education have set (or are setting up) guidelines bodies to regulate their operations (section 4.2.3.3).

It appears, therefore, that as long as the institutions fulfil and operate according to the conditions and provisions provided by the bodies responsible for regulating the operation of these institutions, they should expect no interference. Those which have been chartered are expected to operate within the confines of their charters as well as according to the government guidelines. Most of the institutions did not seem to have a problem with that. The respondent for institution I said that it took some time to convince the government that the institution was different and had a different mission although the government later conceded to this.

#### 4.2.6.2 *Management by the Foundation Body*

The foundation bodies of most of the institutions studied were religious denominations or bodies affiliated to religious organisations. A Ministry of Education official in Zimbabwe indicated that “...so far all the applicants to start universities are Churches. We are looking forward to a time when others...(not religiously affiliated universities) will come up”.

The foundation bodies are diversely organised. Some of the institutions are operated by international or regional arrangements, while some are operated by local (country) or sub-local arrangements such as dioceses. Some of the founding bodies have boards of education which help to plan and supervise education internally while others have education secretariats for the same purpose, as the following respondent for institution B indicated: *“We have a diocesan synod below which is a diocesan council and below which is the diocesan education board. The university falls under the committee of higher education which is under the diocesan board of education”*. Another respondent for institution L mentioned that the university falls under the board of higher education which is under the general conference of the founding Church based in the United States of America. The non-religious institution was managed by a board of trustees who are *“...the registered owners of the university”*

and the multi-religious one is managed by a “...company of 43 members who at the time of the study were made up of church leaders across Africa committed to higher education and holding key places in their various Churches. These people were recommended by their churches”.

It was these bodies that appointed members of the governing councils of the institutions. The company mentioned above, “...meets once a year and on one of such meetings it elected 16 members out of themselves to form the university council”. Likewise in the case of the non-religious university at its inception, the board of trustees elected the university council. For the religious institutions most university councils were elected or appointed by the highest authority of the denomination at the level responsible for the university. The chairmanship of the council is in all cases a denominational leader, as the following response portrays: “We have a University Council which is the board of directors and the chairman is the head of the Church”. The respondent for institution B said: “The Chancellor at the moment is a Church leader and chairs the Board of Trustees”. A percentage not less than 40% of the other members are also denominational leaders. In addition there were members representing government where this is required. This arrangement was not unique to this institution alone. A number of others also had their church leaders as either the chancellors or the chairmen of their governing boards.

As may be inferred from section 4.2.2.1 that the religious institutions that formed part of the sample for the study had various relations with the religious founding bodies. Some were operated by the local organisations such as dioceses, others by the body on a national level and some were operated by regional organisations of the founding body covering more than one country. This, like the management by the government was macro level management. However, although both are macro levels of management, the founding body macro management went beyond what generally government macro level management does - setting policies for the general operation

of the institutions. There was more involvement in the operation of the institutions by the religious macro level management, such as establishing the governing boards and involvement in the selection of the institution leadership, functions which are not performed by the government macro management for private institutions.

This is probably done so that the founding bodies, which are in most cases religious bodies, may ensure that the institutions operate according to the philosophy of the religious faith and fulfil the mission for which they were established. This appears to be true for both the “defender of faith” as well as the “church-related” categories of the institutions (section 4.2.2.2). except for the non-religious institutions.

In all cases the chairpersons of the governing body were chosen from among the prominent members of the founding body. In the cases of the nine institutions which acknowledged full religious affiliation (section 4.2.1.1), the chairperson was either the leader of the religious body in the region served by the institution or one of the leaders in the body such as a bishop of a diocese or a leader of an organisation also affiliated to the religious body. For the chartered institutions and those which were close to being chartered or which had at least received a licence, the chairperson of the institutions’ governing boards was also the chancellor. A chancellor, taking a model from the public universities in the region under study, is the highest ranking individual in the management hierarchy of a higher educational institution at the level of a university. The position of the chancellor, except in cases where the same individual also serves as the chairperson of the governing body, is more honorary than managerial in the opinion of the researcher. The individual, in most cases, does not receive any remuneration for being a chancellor. Functions of management are vested in the governing boards and the institutional management on their campuses.

A possible explanation for having the head of the founding body or a prominent member of the body as the chairperson of the governing board may ensure that the

institutions operate according to the tenets and mission of the founding religious body. The founding bodies further endeavour to ensure that the institutions operate according to the bodies' tenets and mission by participating in the selection of the governing council since the councils are statutorily responsible for the implementation of the objectives of the institutions. It is, therefore, prudent to operate and influence the operations of the universities through these bodies as they are the highest recognised management bodies in countries such as Zimbabwe where no other body beyond the councils of the universities would be recognised to be guiding the decisions made at the institutions. Even in cases such as for institution K, in which the government appeared to have recognised authority above the university council, statutory management of the university is still vested in the council as indicated in the following statement that "*There shall be a council of the university which shall be the governing body that assumes full responsibility over the university*" (Institution K 1997: 851). The council is the official representative of the other bodies recognised in the universities hierarchy and is responsible for the "doctrine, morals and the discipline of the university as well as for its integral development".

Despite the requirement to have government representatives, such as in Zimbabwe where the ministry of education and other educational bodies were represented on the private institutions' governing bodies, the founding bodies still appeared to have more responsibility for governing the operations of the institutions unlike in the public institutions where, according to Saint (1992: 77), the councils were dominated by government representatives, a situation that causes major conflicts. There was no evidence from the institutions that formed part of the study that similar conflicts were present between the founding bodies and the institutions. A possible explanation of this congruity may be the commitment to the mission of the founding bodies by both the founding body itself and the institutional management on campus. The later, which is sometimes referred to as management at the micro level, is more influential in determining the harmonious operation of the institution according to the tenets and

the mission for which the institution was established since it is responsible for the day today operation of the institution and for the implementation of the mission.

In the case of government schools there is a level of management at the district and regional offices in all the three countries studied. This level of management usually has to do with management at the second level within a country at the provincial or district level. It appears, however, that institutions of higher education which grant degrees, in the region under study, were not subjected to much middle level management. This might be due to the importance the governments placed on such level of education as well as the desire for closer control of the kind and quality of education the institutions provided that they could not delegate such responsibility to middle level management. This applied to the public universities as well as to the private universities. Likewise the institutions studied did not have much to say about how they relate to the middle (district and/or provincial) level of management other than the governing bodies' levels.

#### *4.2.6.3 Institutional Councils or Governing Boards*

According to the statutes authorising the operation of universities, their top management is entrusted to the university councils. University charters of those universities that have been chartered, state that the management of the universities is the responsibility of the university council. The following is a quotation from the university charters for institution C: "The Council shall be the supreme organ of the University responsible for overall administration of the University and for ensuring the due implementation of the objects and functions of the University". The charter for institution L, having stated on the subject of governance that "...the university shall be self-governing and an independent institution", further stated: "Subject to the provision of the National Council for Higher Education Act, 1990, and the by-laws of...(the university) control of the university shall be vested in the University Council

which is the Board of Directors”.

The following charter for institution I, on the other hand, recognises a body above the university council when putting forward the section on governance. It outlines the governance of the university as follows: “The governance of the University shall be vested in the following persons and bodies:- (a) the ...(university proprietor) Company; (b) the Chancellor; (c) the University Council, and (d) the Senate”. The same charter then stipulates the different roles of these individuals and bodies stating that the company “...shall oversee the mission of the University...”, while about the council it states that “There shall be a Council of the University which shall be the governing body with full responsibility over the university”, and then goes ahead to outline the membership and functions of the council.

Institution K which also recognised some authority above the university council stated as follows: “The governance and control of the University shall vest in the following persons and individuals:- (a) the Roman Pontiff or Holy See; (b) the Association of Member Episcopal Conference of East Africa (AMECEA); (c) the Council; (d) the Chancellor; (e) the Senate; the constituent colleges”. Likewise, the charter went ahead to outline the functions of these individuals and bodies stating about the council :

There shall be a Council of the University which shall be the governing body that assumes full responsibility over the University. It represents the AMECEA. It is therefore, responsible for the doctrine, the morals and the discipline of the university as well as for its integral development.

The two categories of statements in the charters indicated that in Zimbabwe the governance of the private universities was fully vested in the council as the supreme authority. In this case the government recognised no other authority above the council although the founding body structure may have its own hierarchy of authority as far as the governance of the tertiary institutions was concerned. In the other case there was

recognition that above the council there was a responsible founding body which may have a responsible and capable hierarchy to supervise their tertiary institutions.

Membership of the councils for the institutions studied ranged from fifteen to thirty members. The categories of the membership also varied from institution to institution. In one case the respondent for institution D said: *“Episcopal Conference (which is the founding body of the university) was the governing council with additional members representing the government selected by the government”*.

In all other denominational institutions the membership included a chairperson who was a leader in the denomination or in a religiously related organisation such as the regional director of Southern and Eastern Africa of the Campus Crusade for Christ or Life Ministry who according to the respondent for institution G *“...is not a Church leader but a leader of a Christian movement”*. The council also included representation from the denominational clergy and others from representation of government where it was required. The respondent for institution C for example said: *“The laws of the university provide that the government nominates five members, the Islamic Conference nominates five and then others are ex officio members making a total of 16 members”*. The ex officio members are nominated by virtue of their positions in connection with the university including the leader of the students association.

A respondent for institution L gave an outline of the membership of the council as follows:

We have four members representing the Board of Higher Education, two represent the Board of Global Ministries, two represent the European Methodist Church, eight to twelve represent the Africa Conferences, two are business men from around ...(the city in which the university is located), two are Government representatives, two members of staff and the President of the Students' Council.



Both the Board of Higher Education and the Board of Global Ministries were referred to in section 4.2.2. The membership of the councils of the rest of the denominational institution had a similar structure with a few differences such as the apparent one in the above two whereby one did not have staff representatives on the council while one had. The representation by members of the clergy also varied from institution to institution but no institution studied was without such representation. This may be similar to what prevailed in public tertiary institutions where a few university councils were dominated by government representatives (Saint 1992: 77), a situation that according to Saint (1992: 73) was a major source of friction between universities and the governments concerned.

The responsibilities or functions of the council were outlined in the official documents of the institutions particularly those which had been chartered or registered. These included the control of the mission and philosophy of the institutions and appointment of the chief executive(s) of the institutions. For example, the functions of the council of institution L, also referred to as the board of trustees are listed as, (Institution L Act, 1992: 122) (identity protected):

- the appointment of the Vice Chancellor, all assistant Vice Chancellors, faculty deans, the registrar, the bursar and the librarian;
- institution and abolishment or holding in abeyance of professorship, associate professorship, and other academic and non-academic offices;
- receiving and giving, if necessary, reports and recommendations from the senate on matters it is authorised or required to perform;
- causing to be prepared annual statements of income and expenditure of the university and of assets and liabilities;
- submitting annual statements of income and expenditure to an auditor it has appointed for audit;

- requiring to be prepared annually estimates of income and expenditure;
- receiving recommendations from the senate for the conferment, withdrawal or restoration of degrees and other academic and honorary awards;
- administering the property of the university and controlling its affairs and functions;
- doing such other acts as it considers to be necessary for the proper administration of the university and the achievement of its objectives.

The responsibilities of the other universities councils were quite similar to the above with a few differences in wording and in areas of relationships with their founding bodies such as the following comment from institution K illustrates: “...to approve statutes and recommend to the Sacred congregation for Catholic education any change in the norms in consultation with the AMECEA”.

The more influential level of management, however, that makes daily impact on the life of an institution is management at the institutional level. This is the subject of the next section.

#### 4.2.6.4 *Management at the Institutional Level*

Below the governing boards the management of tertiary institutions is entrusted to the chief executive(s). At this level, as was the case with the governing council level, there were variations in the structure. Many of them appeared as a merger between the structure used elsewhere by the sponsoring organisation and the local government structure. The chief executive of universities who have management responsibilities were referred to as the vice chancellor following the tradition of the public universities in the region. It has already been indicated in section 4.2.6.2, private chartered universities had a chancellor who was, in most cases a church leader but had no management responsibilities except acting as a chairperson of the governing body

in some cases. In a few cases the term rector was also used sometimes side by side with the term vice chancellor for example, in institution K. In cases of non-university tertiary institutions the term principal was used. For those which had evolved through some stages, as soon as they became universities the term was changed from principal to vice chancellor upon attaining the status of university. The person who occupies the position of vice chancellor, appointed by the institutional governing council, was responsible for the day-to-day management of the institution.

Other top executives in the management of these institutions included “...*the deputy vice chancellor and business manager*” according to a respondent for institution G but with various titles used by the different institutions. Some respondents included positions of the registrar. Others referred to the assistants to the vice chancellor as deputy vice chancellors or pro vice chancellors responsible for finances, development, academic affairs and student affairs. The latter two were also referred to as academic deans and deans of student affairs in some institutions, while those responsible for development were also referred to as directors of development and registrars were referred to as directors of records. The position of a university secretary was also referred to once by the respondent for institution E. It was a term that was used in public universities in some countries as a top administrative position responsible for general administration and personnel matters. In institution I the chaplains were included in the list of management for the institution. In many of the smaller institutions “...*some of these positions were not yet filled*” as intimated by the respondents for institutions B, G and J, respectively.

Two respondents said their institutions’ personnel responsible for development were stationed abroad for purposes of raising funds for the institutions. The following response by the respondent for institution J portrays this situation: “*The Deputy Vice Chancellor for development is residing in the USA doing a lot of fundraising. His position is like a title, but it is more effective if he is out there doing fundraising*”. In

such a case the office is primarily fundraising rather than any other management function at the institution.

Below these top management positions at the universities were deans of schools or faculties and chairpersons of departments. In documents of most institutions documents, various committees were also listed beginning with what were referred to as the administrative council or board and the senate. In some institutions these two committees were combined such as implied by the following response: "*We have a Senate in the place of the Administrative Board*". The main role of the administrative council/board is to advise the chief executive on the running of the institution. A respondent for institution F said: "*Administrative council looks after the day-to-day operation of the university as advisory to the Vice Chancellor*". Its membership varied between institutions but all those who were considered to be top administrators were members with some additional representation of the teaching personnel, as the same respondent for institution F indicated that "*...it (the administrative council) comprises the Vice Chancellor, the deputies and a faculty representative*". The senate whose membership generally comprises all the administrators, the registrar, the librarian, deans of faculties or schools and chairpersons of departments in most institutions is responsible for academic policies and administration of the academic faculties and departments. Another committee that was mentioned by some respondents is the appointments committees responsible for appointment, ranking and promotion of institutional teaching personnel and other supporting personnel. The functions of this committee in at least one of the institutions studied were still performed by either the institutional governing councils or the administration councils/boards as the following statement by the respondent for institution A implies: "*The University Council acts as the appointments committee*". In other cases where these committees existed, such as for institutions F and H, the university council has representatives on the appointments committee.

With these committees in place in many of the institutions there appeared to be involvement of and participation by lecturers in the management of the institutions studied. However, informal contact and observation pointed to some dissatisfaction with the level of involvement in management and decision making among some institutional personnel in some institutions, which is another potential source of friction within institutional management. *“The few meetings we have here are to receive instructions. This university is being operated as a little primary school or a personal business”*. This statement implied lack of satisfactory involvement in meetings which would be one form of involvement in the decision-making procedures of the institution. This feeling, however, did not appear to be widespread among the respondents.

Management of the institutions at the institutional level, like the governing board level was very similar to the local structure in the countries where the institutions are situated. There were also differences among institutions in a country in an attempt to incorporate the structures of the founding bodies elsewhere. This differed for the various religious bodies.

In summary, therefore, at the micro level management which refers to management at the institutional level, also referred to as the operational or local level (Van Wyk 1994: 5 and Van Schalkwyk 1993: 65), for all institutions, the management team is led by the chief executive. He or she is referred to as the vice chancellor particularly in the chartered institutions. The term rector is used by institutions C and K in conjunction with the term vice chancellor. The chief executives along with their assistants in administration are selected by the governing body in all institutions studied. This is one of the major functions of the governing body as implied by statements by institution councils for institutions F, I, H, K and L that one of the functions of the council is to appoint the chief executives and their assistants in administration. They are not appointed by the founding body although the founding

body may exercise some influence usually through representation on the governing body.

The chief executive of the institution is in all cases expected to work through or be advised by an on campus management committee referred to, most commonly, as the administrative boards or councils. These committees are responsible for the day-to-day management of the institutions. Other committees which were mentioned such as the senate, the appointments committee, the library committee, the discipline committee are sub-committees of the administrative boards/councils with specific responsibilities on different aspects of the institutions (sections 4.2.3.3, 4.2.6.3). It was observed that in some of the smaller institutions (section 4.2.2.3) some of the functions of the various committees are performed either by the administrative boards/councils or the governing bodies as exemplified by the following response by a respondent for institution A that “...*the university council acts as the appointments committee*”.

Membership on the administrative boards/councils was observed to always comprise of, at least, the chief executive and the top assistants who are variously referred to as deputies or pro-vice chancellors for various duties such as academic, finance and students; as well as the registrars, the institution secretary, and in one case, the chaplains and faculty representatives. A respondent for institution F mentioned that the faculty representative is changed every quarter. This was done in an attempt to give more members of the faculty opportunity to participate in the management of the institution, thus encouraging participatory management and involvement. In institutions where the senate existed, it was the second most important committee on campus comprising mainly the faculty deans and department chairpersons as well as the institution's top administrators, the librarian and the registrar; and had specific duties to deal with academic policies primarily. On the other committees the membership varied and was mainly made up of members of faculty with the

administrators as ex officio members.

As far as the functionality of the committees is concerned, some dissatisfaction was expressed informally and in the open by some members of the faculty of institution H who said that "*The few meetings we have here are to receive instructions. This university is being operated as a primary school or as a personal business*". This statement, as seen above, implies that there is some lack of satisfaction with the amount of involvement. This feeling did not appear to be widespread among many institutions, however. The researcher had opportunity to examine the minutes of the various committees of institution H and discovered that there were minutes reporting membership and presence including many of the faculty members. The researcher is of the view that this is an issue whose authenticity can only be ascertained by extended stay in the field to be able to mingle with as many faculty members' activities as possible and attend some of the committees but this was not the subject of the present study. If it actually is the case, in the opinion of the researcher, this ought to be changed and more involvement in all activities of committee preparations, deliberations and implementations should be encouraged.

The management at the micro level did not appear to have problems or areas of contention with the administration at the macro level both by the founding body or the governments. There was a need to clarify the relationships between the government management, the founding body management and the institutional management as well as for steps for recognition of the institutions in Uganda. It is the opinion of the researcher that there ought to be mutual recognition and respect between the government and the management by the different levels of proprietors of private institutions, some of which are outside the countries where the institutions are based.

#### **4.2.7 Educational Basic Concepts of the Different Religious Persuasions**

The basic concept, which normally develops into a philosophy of education, is an attempt to view education in a comprehensive, penetrating and flexible manner. It is an attempt to help the students to develop insights into the comprehensiveness, penetration and flexibility displayed by the philosophical mind in attacking problems of education other than solving problems on the level of tradition, expediency and narrow common sense. Ozmon and Craver (1986 : ix) define philosophy of education as the application of philosophical ideas to educational problems. The same could be extended to basic concepts as the application of basic ideas to educational endeavours and problems. It is the basis for analysing different aspects of education and what takes place in an educational institution. The philosophy of education assists in clarifying the world view and the goals of an educational system as well as the educational institutions operated in that system. All these aspects are functions which management performs in an education system and in clarifying the mission of the institutions operated in the system.

The following discussion is meant to provide a general understanding of the beliefs and basic concepts of education of the Catholic Church, the Anglican Church, the Seventh-day Adventist Church, the Muslim faith, the Methodist Church and the Nazarene Church as background information to the synthesis of the research results. This basic concept shapes, or should be expected to shape the management of education including the management of tertiary educational institutions affiliated to those religions.

##### *4.2.7.1 The Educational Basic Concept of the Catholic Church*

The Catholic Church's basic concept of Education is that:



...to educate is to cultivate, develop and polish all the faculties - physical, intellectual, moral and religious - and to give a boy's whole nature its completeness and perfection, so that he may be what he ought to be and do what he should do, to form him as a man, and to prepare him to do his duty in life to those about him, to his country, to himself, and so, by perfecting his present life, to prepare him for the life to come... (McClelland 1988: 62).

This basic concept has been able to cohere because Catholicism presents itself as the only religious system that possesses an infallible authority received from the word of God and the divine mandate to teach is at the heart of its scheme of religious formation (McClelland 1988: 62).

This doctrinal authority referred to as *magisterium* is believed to have been given to the Catholic Church by Christ Himself and includes all the rights and privileges necessary for the effective teaching of divine revelation and guarding intact the deposit of faith (Graham 1963: 711). This infallibility extends to both the tradition of Christian faith and the manner of life or morals and is concerned with what people believe and do if they are to be saved. Education is among the important preoccupations of the Church. The government's responsibility is to foster the common good of its citizens and to provide for their temporal well-being but can not disregard the supra-temporal aspirations without which human-kind can not be happy which are the responsibility of the Church (Graham 1963: 728). These considerations indicate the need for clear distinctions between the responsibilities of both the Church and the government and the need for harmonious cooperation.

#### *4.2.7.2 The Educational Basic Concept of the Anglican Church*

The Anglican is also referred to as the Protestant Church but historically as the Church of England in the region of study because of its origin. The principles on which the Church operates its colleges according to Wynn (1975: 14-19) are:

- the college is student centred rather than knowledge or skill centred;
- values are a primary concern of the college. It is not aloof or neutral to values but is against indoctrination and dogmatism;
- the college holds a healthy respect for the place and role of the church in society and regards itself and the church as allies working for the best of the human mind and spirit. It feels a special responsibilities for training church leaders in the same way as it trains for other sectors of life;
- the college places much emphasis on the maximum amount of individual attention for its students and prefers small enrollments to be able to do this but being aware of the need for economic viability;
- the college emphasises fundamental truths and knowledge and believes that truths sharpen the mind in ways that can not be expected by accumulation of facts;
- it endeavours to integrate as well as extend knowledge so that students can see the relationship of various fields of knowledge;
- believes that academic freedom is a major strength by providing independent study and individualised instruction as far as it is financially viable and its teachers are free of political and community restrictions;
- the college prepares its students for individual responsibility for public service; and there is a strong tendency toward mission and integrity as well as excellence.

#### *4.2.7.3 The Educational Basic Concept of the Seventh-day Adventist Church*

The educational basic concept of the Seventh-day Adventist Church is rooted in the belief in God as the creator and sustainer of the earth and the entire universe and as the source of knowledge and wisdom, (Eastern African Division of Seventh-day Adventists 1995: 2). The aim of true education is, therefore, to restore in humankind the image of God which was lost when sin entered into humankind. From this general

statement of basic belief the Seventh-day Adventist Church operates different levels of educational institutions to ensure that the Church's youth "receive a balanced physical, mental, moral, social and vocational education...", (Eastern Africa Division Of Seventh-day Adventist, 1995: 3). The educational institutions operated by the Seventh-day Adventist Church are for purpose of transmitting to the students the ideals, beliefs, attitudes, values, habits and customs; and for fitting them for the effective citizenship on this earth and for rewarding citizenship in the new earth, (Eastern Africa Division of Seventh-day Adventists 1995: 4).

Stating the educational objectives the Seventh-day Adventist Church makes a distinction between objectives of higher education and those of graduate education. Institutions of higher education are operated for the purpose of successfully providing special opportunities for youth of the church after secondary school and are desirous of pursuing academic courses for a degree for purposes of work and further education. The institutions help develop in the students ethical, religious and social values compatible with church basic concept and teachings in preparation for work life and/or further education, and developing in the students a concept of service to fellow human-kind and to God. Graduate education aims at the mastery, critical evaluation, discovery, and dissemination of knowledge by the students and the nurturing of wisdom in a community of Christian scholars. The training of leaders for the church and its subsidiary enterprises and elsewhere as witnesses for God is part of the purpose of graduate education.

It would be expected of institutions affiliated to the Seventh-day Adventist Education to have in their mission, statements that reflect the above basic concept and general objectives. Having reflected them in the statement of mission it would further be expected for the institutions to implement them and to have an atmosphere that is totally governed according to these principles.

#### 4.2.7.4 *The Educational Basic Concept of the Muslim Faith*

According to Husain and Ashraf (1979: 36) Islam does not believe in the original sin that humankind is inherently sinful. Islam believes that every child is born in the state of innocence and only succumbs to temptation in order to sin. He/she has the capacity for good. This essential goodness of human nature, accountability and commitment to a set of God-given primordial values formed the foundation of Muslim education. The true aim of education, therefore, according to Husain and Ashraf (1979: 37), is to produce people who have faith as well as knowledge. Islam attaches great importance, in its education, to faith and piety.

The aim of Islamic higher education, according to Bilgrami and Ashraf (1985: 40), is not merely to “provide ‘higher education’ as a training of the mind or to deal with the ‘high’ truth or to prepare for higher ‘callings’”. It has to produce men of higher knowledge and noble character, enlightened with higher values, having an urge to work for the betterment of their own inner selves and of humanity at large.” The Islamic university should differ from other universities in its concept of education of leading people to what is referred to as ‘the straight path’ of happiness and blessing and that there cannot be complete education without a spiritual base. A similar concept is, however, inherent in the basic concepts of other religious educational institutions as seen in section 4.2.7.3 only Islam is more than just a religion but a way of life (Oberholzer *et al.* 1993: 97). It is expected to govern all spheres of life including religious, social, economic, political, juridical, ethical, and aesthetic spheres.

Bilgrami and Ashraf (1985: 49) further contend that an Islamic university does not come into existence just because there is money, a charter, buildings or many students. It should, from the very start, be research-oriented realising that it is fighting a basic challenge of other human reason-based research which does not believe in

revealed truth. This probably explains why there are not as many Muslim universities as there are other religious universities. In order to carry out this basic concept Islam requires imaginative, highly dedicated, widely experienced, fully devout and acutely intelligent persons as administrators of a Muslim institution, (Bilgrami & Ashraf 1985: 52). Additionally, Bilgrami and Ashraf (1985: 57) argue that an Islamic university should include a course in General Islamic Education in its curriculum which should be compulsory for all students.

#### *4.2.7.5 The Educational Basic Concept of the Methodist Church*

Early Methodist education was founded after Wesleyan education and was highly disciplined. In the school at Kingswood, which was founded by Wesley, a child was dismissed if he/she missed two days in a week without permission and there was no talking in school except to the masters. No holidays were originally allowed because Wesley believed that “he who plays as a boy will play as a man” (Andrews 1970: 73). Holidays were later allowed. Wesley believed in the full sanctification of the will and the notion of perfection has long been a distinguishing mark of the Methodist tradition (Griffin 1984: 49, 50). He was thoroughly committed to the importance of education for all (Chibanguza 1998: 1). In keeping with the Wesleyan legacy (Chibanguza 1998: 1) the Church believes that religious higher education is necessary because God created the universe to function according to fixed laws, order, and government, and made human beings as free rational creatures; and that God “...made man for knowledge, and therefore, for education”(Payne in Griffin 1984: 70). According to Chibanguza (1998: 1) “...the religious dimension was considered vital as it would serve the individuals with opportunities to nurture faith and learning just as the individual serves God and society more fully”.

According to Stanley and Stanley (1997: 314), Wesley affirmed human reason as one of the four pillars of the Wesleyan/Holiness movement on which the Methodist

Church was founded, regarding reason as a gift of God reflecting the mind of God. This positive regard for reason, according to Stanley and Stanley (1997: 314), generated positive implications for higher education in the movement.

Like the other Christian religions the Methodist Church therefore firmly believes in education and has established many educational institutions of different levels in the region as well as in other parts of the world including theological seminaries. Stanley and Stanley (1997: 318) argue, in this regard, that “Although a strong belief in the eminent return of Christ led people to sing ‘This World Is Not My Home’, a concern for this-worldly obedience prompted them (the Wesleyan/Holiness adherents) to establish missions and plant colleges to train leaders for future generations”.

#### *4.2.7.6 The Educational Basic Concept of the Nazarene Church*

Beginning with a view that God as Creator and Lord guides the purpose of living and learning rather than a view of man as the ultimate being of the universe, the essence of education in the Church of the Nazarene is also rooted in biblical and theological commitments of the Wesley and holiness movements. It aims at guiding those who look to it in accepting, nurturing, and in expressing service to the world and consistent and coherent Christian understanding of social and individual life (The Working Committee of Institution J 1991: 9).

The Church of the Nazarene traditionally considers education to be vital for all its adherents regardless of their calling because without it one cannot function well. The Church believes that there is no conflict between the best in education and the best in Christian faith but rather that the best in education is Christian education. The Church of the Nazarene believes that Christian values and experiences change lives. One of the goals of the Church is to develop individuals into leaders who will infiltrate all institutions of society with a Christian world view by training students to blend the

liberal arts and professional training into the “Living Arts” (The Working Committee of Institution J 1991: 10). According to the Church of the Nazarene “Liberal Arts” does not mean liberalism or humanism but a free study of all life combining understanding from all branches of knowledge into a coherent view of living. According to Kirkemo (1997: 346), the liberal arts ideal

...is more than breadth in knowledge; it is a state of mind that rejects narrow and set answers. It seeks to impart intrinsic values through moral reflection on the great issues of life. Liberal education expects education to expand , paradigms to shift, and interpretation to change; to that end it promotes creativity, exploration, and discovery of new knowledge. It seeks intellectual coherence, but without dogmatism.

Higher education institutions of the Church of the Nazarene seek to provide a curriculum, quality of instruction, and evidence of scholastic achievement that will adequately prepare the graduates to function effectively in vocations and professions of their choice as Christians (The Working Committee of Institution J 1991: 9).

Kirkemo (1997: 358) summarises what the Nazarene Church expects from its colleges: that it keeps the ‘fires’ of personal spiritual experience real among its students; that the faith of its young people not be shaken and that modern thinking including modern hermeneutics may be tolerated as long as it does not weaken the faith of the students; that the concept of holiness be kept alive; that the college does not get too far ahead of the church in ideas and values, expecting essential congruence with the established denominational ethos; that the faculty continue to regard the church doctrines with warm feelings and that the church remains in effective control of the college so that it does not become interdenominational or separate.

Considering these basic concepts embraced by different religious groups on the surface, they appear not to differ that much. However, the adherents see beyond the trivial and consider the inherent beliefs as an inspiration to establish different

institutions of learning despite the enormous amount of resources required. Part of the explanation for this sacrifice is based on historical justification.

#### **4.3 A MODEL FOR MANAGEMENT OF PRIVATE RELIGIOUS TERTIARY INSTITUTIONS**

Based on the foregoing discussion and the reality that private religious tertiary institutions operate within a dual system (section 4.1) it is imperative to have mutual understanding amongst the management systems. It may be inferred that the governments value the contribution made by these private endeavours to provide the needed higher education to the aspirants. Moreover, religious bodies which are involved in the endeavours appear to have with good intentions. However, in order to maintain the academic standards required for such a high level of education and to ensure that some do not take advantage yet, on the other hand, avoiding the temptation of over controlling on the part of the government, the researcher proposes a management model that takes into cognisance these factors for the management of private religious tertiary institutions. The model is presented in the following diagram:



Figure 4.1 A Model for Management of Private Religious Tertiary Institutions

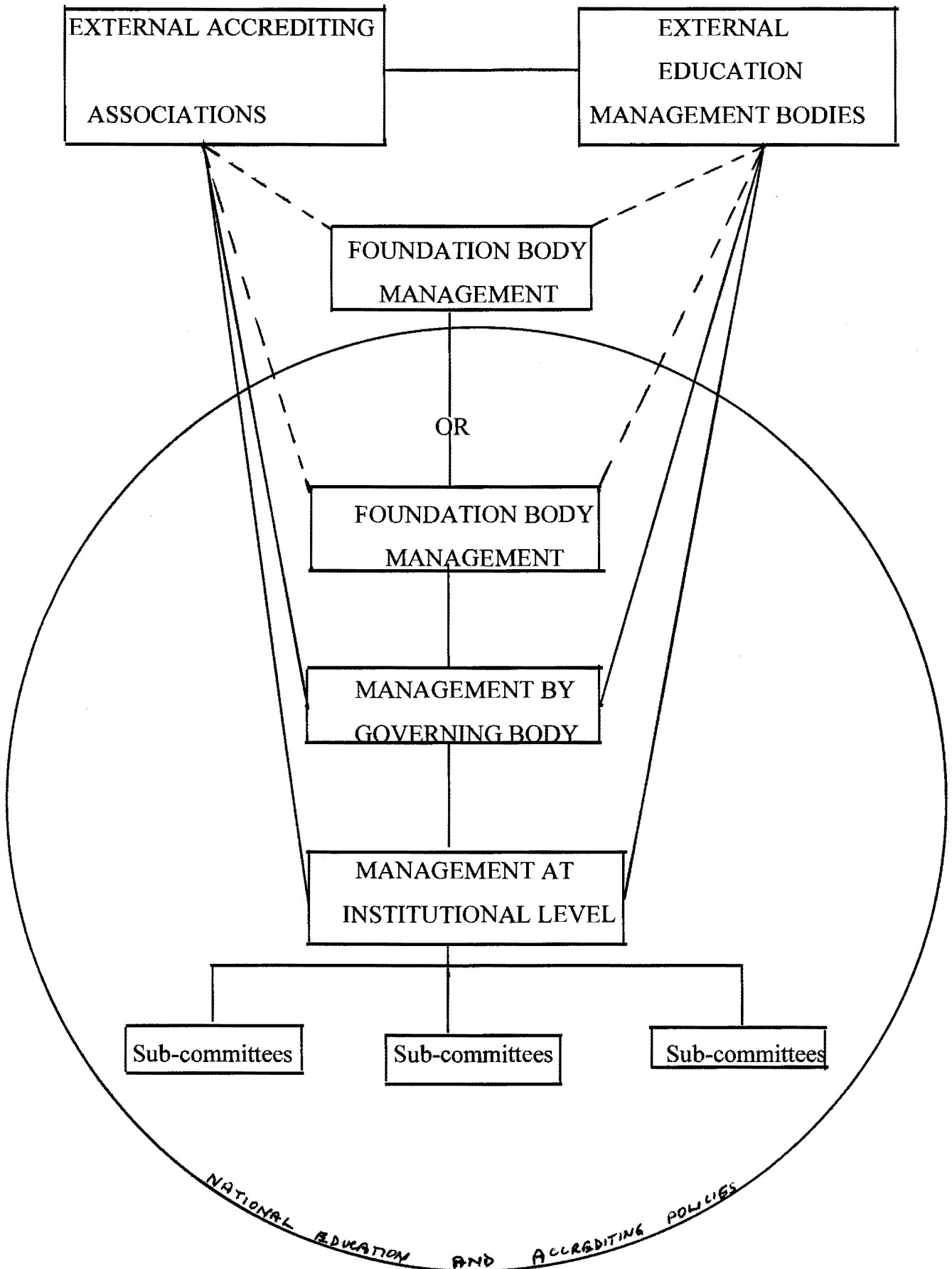

In this model external education management bodies refer to those bodies within the hierarchy of the founding bodies whose responsibilities include supervisory and advisory roles for the founding bodies such as the International Board of Education in the case of institutions F, H and J and the Board of Higher education in the case of institution L. These are entrusted by the founding bodies to supervise and advise the bodies as well as the institution on matters of education. Their role should be recognised by the national governments where the institutions are located while they also should operate within the policies of the national governments on higher education represented by the circle.

External accrediting associations are those which regionally or denominationally are responsible for accrediting educational institutions such as the Accrediting Council of Theological Education in Africa (ACTEA) and the Accrediting Association of Seventh-day Adventist Schools, Colleges, and Universities or, in short, the Adventist Accrediting Association (AAA). In addition to the education management bodies referred to above some institution would like to keep accreditation with regional, or denominational accrediting bodies for further standardisation and recognition of their programmes. These accreditations should be recognised as well by the governments while the institutions should operate in accordance with the national education and accreditation policies. This kind of harmony would enhance mutual understanding and support which the researcher feels is important in the field of higher education.

Operating within the national education and accrediting policies represented by the circle, there are cases in which institutions are related to their founding bodies on the national level, where the foundation body has a national Foundation body management such as dioceses that take care of matters including those of education. In other cases the management body is regional. Where this exists it should be given due recognition above the governing bodies. Institutions which are of a regional nature may not have this arrangement. In both cases, however, the researcher feels

that the responsibility of operating the institution is rightly placed under the governing bodies of the institutions which deal with appointments of administrators and other policy and governance matters.

Below the governing body are the institutional management committees which are responsible for the day-to-day operation of the institutions and for advising the chief executives on such operation. Further below these institutional management committees are the sub-committees which should be answerable to the institutional administrative boards/councils for their various responsibilities.

The solid lines in the model represent required consultation and/or accountability. The dotted line refers to desirable consultation. The researcher is of the opinion that representational participation as is stipulated should be encouraged at all levels. It is not possible to involve every stakeholder. The possible way of encouraging this participation is through representation of the different stakeholders on certain committees to enhance transparency, accountability and adherence to the missions of the institutions. The degree of representation should be left to each institutional governing body to determine.

#### **4.4 SUMMARY**

In this chapter data collected on the subject of management of the institutions studied was presented and discussed under different categories arising from the interviews, document analysis, observation and the questionnaire. These included the nature of private religious institutions in the region under study, the various relationships that exist, the funding of these institutions, their accreditation, their management structure and the different religions basic concepts of education.

Universities, according to Parker (1986: 164), are both complex organisations and

difficult to manage. This statement which according to Parker (1986: 146) has “ample support “ appears to be true in the institutions studied although the development of private tertiary institutions is still new. Being a recent development may make all the more complex as statements such as the following implies: “Private higher education is beginning to receive some encouragement.... However, the level of economic development is such that private education cannot expect to flourish to the same extent as in Asia or Latin America” (Sanyal *et al.* 1996: 50). On the other hand, if private universities start off on a strong base, they can withstand many of the current challenges and problems in public institutions.

The complexity is exacerbated by what Odhiambo (1996: 5) in a graduation address to one of the institutions studied referred to when he quoted the Association of African Universities (AAU) 1990 colloquium’s conclusion that:

One of the key issues was the anachronistic, alienating nature of the governance structures that were historically established using European/Western models inherited from colonial times. This has partly contributed to the inability of the universities to respond properly to societal needs and to the challenges of social economic changes in Africa.

This statement may apply to the new private universities as well since they too, to some extent, emulate the structures of the foundation bodies which may be foreign to the situations in which the institutions find themselves and may affect the quality of the education offered and the graduates therefrom. On the other hand establishment of quality higher education would help to satisfy the great demand for education while providing an alternative for the governments. The competition that may arise from such diversification may, as well, assist in improving the quality of education in the long run.

The emulation of characteristics of the founding bodies have influence on the nature

of the institutions. The nature and characteristics of the institutions studied were therefore varied because of their varied backgrounds and the different founding bodies. Even within the same country or within institution related to the same religious body there were still differences in the basic nature and characteristics. Most of the institutions were still small institutions compared to the state universities and there were a few differences of opinion regarding the size of a religious institution although all respondents implied that the smaller size was more effective in creating the atmosphere they desire. Some of the institutions were non-residential while some were residential or partially residential.

The various relationships revealed that within the institutions, despite some student related problems in some of the institutions, they endeavoured to maintain good relationships within just as much as with the surrounding communities. There were no formal relationships with other private religious institutions as they were all still new but attempts had been made in one of the countries to establish a forum. By the time of the study this had not yet been accomplished. There was, however, no evidence of hostility or rivalry between the institutions in any of the countries. The same kind of relationships existed between the private religious institutions and the public ones although there was an expression of fear of rivalry when the public institutions seemed to emulate the same systems and programmes as those which were being established by the private ones.

There were varied answers on the question of funding although all respondents cited student fees as the main source of funding. There was no agreement on the issue of government funding although most of the respondents said they would receive the funds from the government depending on the conditions under which such funds were given. Only one respondent was outright in objecting to government funding.

Accreditation and management structures were rather related because it is through

accreditation that the government's management responsibilities over the private institutions are executed. Two of the three countries that formed the population of the current study had established legal bodies and procedures of how accreditation and management of private tertiary institutions would be achieved. The third country was in the process of doing likewise. It was these procedures and statutes which outlined the management structure of private education in general on the macro, middle and on the micro levels. Differences were observed mainly at the micro (institutional) level because most institutions emulated, to differing degrees, the structures of the founding religious bodies. It was also observed that there was representation on the management of the institutions particularly on the governing council levels.

The different religious persuasions have embedded within their fundamental beliefs certain basic concepts of education. These drive the different churches to establish educational institutions of different levels and to some extent influence their management structures. On the surface, however, it was discovered that these basic concepts appear similar. The different religious organisations, in addition to considering them seriously, see in them differences and therefore endeavour to establish different educational institutions. It is these basic concepts that give rise to the different philosophies and missions of education. The next chapter presents and discusses data related to the missions and mission statements of the institutions studied.

## **CHAPTER 5      RESEARCH FINDINGS: MISSION AND MISSION STATEMENTS OF PRIVATE RELIGIOUS TERTIARY INSTITUTIONS**

### **5.1      INTRODUCTION**

In the previous chapter data collected on the subject of general management of private religious tertiary institutions was presented and discussed. In the present chapter findings related to mission and mission statement are discussed under the categories identified from the findings of the study through interviews, observations, document analysis and from the questionnaire in a similar manner as mentioned in section 4.2, as well as from literature. This involved identifying clusters of similar responses which emerged from the data, grouping them in patterns which were further examined in comparison with what is available in literature and regrouped into categories. The next section outlines the categories identified.

### **5.2      CATEGORIES IDENTIFIED**

An interview schedule designed to elicit understanding of the problem under study in line with the aims of study was used to conduct the interviews which were the main research instrument. The interviews did not follow any strict order, but they were useful in obtaining information on the different aspects of the problem. Arising from these the following categories emerged and form the sub-topics of this chapter.

- Mission and mission statements;
- Mission statement development;
- Mission statement reformulation;
- Mission in the practical life of an institution;
- Dissemination and articulation of institutional mission; and

- Curriculum and missions of institutions.

### 5.2.1 Mission and Mission Statements

Just as was seen in section 2.7.2 literature study indicated that there appear to be no agreement as far as the definition of the word mission is concerned. Likewise the institutions studied portrayed an array of various understandings and interpretations of the term mission and the ensuing mission statements although all of them argued that they had a mission expressed in some form of mission statement. However, in institution K, the respondent who was the chief executive and relatively new to the position, confessed not having come across the mission statement of the institution when the researcher visited the institution for the first time. When the institution was visited the second time after four months the institution had a statement of mission newly developed. The respondent argued that the institution could not operate for long without such a useful tool and a number of other respondents referred to the mission statement as a useful tool in their institutions, agreeing with the definition given in sections 2.7.2. and 2.7.3.

Respondents referred to their institutional missions variously, such as “...*the commission given to the Church by Jesus Himself as recorded in Matthew 28: 19, 20*”, as intimated by one respondent for institution I. “*It is to make disciples for the Church as in the great commission found in Matthew: 28 19, 20*”, said another respondent representing institution H. One other respondent representing institution K answered that “...*our mission is the motto of the university*”.

In one institution bulletin the mission was given as the philosophy of the institution and two others went straight into outlining the objectives of the institutions as their mission. This appears to be an isolated case because notwithstanding the multiple understandings both in literature and in the research findings, most respondents



separated the statement of philosophy, mission and objectives. Most respondents portrayed the philosophy of an institution as limited to the basic beliefs that the institution considered important and which formed the basis for the mission statement as a world view. The mission statement, on the other hand was defined more generally than the objectives of an institution. The objectives followed after the mission statement but did constitute the mission statement.

#### *5.2.1.1 Mission Statements*

The following are responses about mission statements and excerpts of mission statements from the institutional documents collected. Respondents had various understandings of what a mission for an institution is.

The respondent for institution A said that:

The Institution endeavours to foster the holistic view of education including the harmonious development of the mental, the physical, the spiritual, and social faculties. It is owned by...(a church organisation). Its (the institution's) mission inheres in the provision of a liberal, yet functional curriculum in arts and sciences and in professional preparation in business, education and theology.

Throughout its programmes of instruction, research and public service, the university seeks to enlighten the mind, to enhance the quality of personality, to enable each individual, out of Christian love and concern, to serve mankind creatively, responsibly and humanely and to enkindle a never ending search for knowledge and truth.

The university seeks to provide a physical environment and appropriate

academic and student support services to facilitate the variety of human interaction and relationships essential for learning and to provide programmes and facilities which allow for continuous evaluation, growth and expansion of the institution.

The above statement for that institution was also available in written form in the institution's bulletin where it was immediately followed by a philosophy statement and then a statement of its objectives.

This institution, therefore, makes a distinction between the statement of philosophy and the mission statement of the institution although the latter depicted its philosophical basis by acknowledging the holistic nature of education which according to the philosophy statement states that the university "...holds as its philosophy the holistic view of man...". The stressing of the physical, mental, and spiritual faculties was also in accordance with the "3H's" philosophy of the institution which refers to the emphasis of training the head, the hand and the heart. The values emphasised in the mission statement include quality, Christian love, concern for mankind, responsibility, and humaneness. The institution also recognises the difference between an institution's mission statement and its objectives which are supposed to be more specific. The institution's statement of mission further identifies who is providing the services by identifying who the owner of the institution was. In outlining what the institutional services are the statement outlined the conventional universities' functions - "...instruction (teaching), research and public (community) service", but was not clear as to whether there was any emphasis on some and not the others of the tripartite role of university education. The recipients of the services were mentioned to be primarily students. The statement does not, however, delineate the recipient in terms of territory and any other delineation, if applicable. The four respondents from this institution who responded to the questionnaire generally rated the mission statement average (see table 4.3) on the scale developed by Campbell and

Yeung (1990: 240) to assess how good a mission statement is. A copy of this scale is part of the questionnaire in appendix C2.

Respondent for institution B responded that the mission was “...to provide the much needed education with a Christian perspective”.

The respondent went ahead to explain that: “...we want to make a difference, to produce a teacher, for example who is not simply to teach but a teacher turned out to teach with ingrained Christian values, to make a difference whether he is teaching Christian religious education or geography, mathematics, language or even business administration”.

While this may be a good statement of vision, it should have been explicated in a mission statement which, according to Davis, “involves discerning what the institution does; whom it serves; and where, when and how it provides these services” (Davis (1986: 99). Among the documents provided by this institution, however, which included the draft articles of the university, there was no written mission statement. There was instead a statement of objectives and philosophy in the draft articles of the university. These gave the philosophy of the institution, its values as well as its objectives but these were not concisely and succinctly stated in the mission statement. The only one respondent to the questionnaire for this institution marked having not seen the mission statement and did not therefore complete its assessment (table 4.3).

For institution C only the written mission statement was provided in the form of objectives in one of the documents of the university referred to as Basic Information for 1996/97. They were referred to as “Objects and Functions of the University” in the University Statutes. The statutes stated in outline form that the ...(university) was established with the following mission (Institution C Act 1990: 84, 84): (Identity

protected)

- functioning as an academic and cultural institution within the Organisation of the Islamic Conference in accordance with its Statute;
- promoting and enhancing the civilisation and scientific influence of Islam, to promote culture and science among African peoples and to contribute to rapport and solidarity among such peoples;
- giving special care to Islamic studies and research, teaching Arabic and making maximum contribution to the spread of Islamic culture in African countries;
- enabling African countries to assimilate science and technology, to acquire scientific and technological know-how and to use it in the best interest of African countries and their peoples;
- training adequate manpower and securing the necessary methods for higher education, scientific research and advanced studies in the various fields of knowledge;
- promoting cultural, sports, social and scientific activities within the university; and
- awarding its own degrees, diplomas, certificates and other academic awards.

In the statutes the above statements were rightly captioned as statements of objectives and functions rather than mission because the form in which they are is rather that of objectives than a statement of mission. The statements do not include a statement of philosophical basis or the values espoused by the university. They, however, mentioned the identity of the university by identifying the proprietor; the key services as training and scientific research; and delineated the recipients of the services as Africans of the English speaking countries. The only one respondent to the questionnaire rated the mission statement as below average (table 4.3). This may be

because of its not being in the form of a mission statement.

The respondent for institution D said that “...the mission and objectives are included in the brochure...but are basically to run a Christian institution inculcating Christian values”.

What was contained in the brochure, however, was a statement of philosophy and a summation of the objectives of the University. The mission of the institution was not succinctly explicated in the form of a mission statement. The documents, however, included the services the institution offers which are training and educating; but the delineation of the recipients of the services was not very clear other than mentioning the entire population of the country. The values espoused by the University included moral responsibility, quality, equality among all peoples and non-discrimination. This is probably the reason why the institution does not delineate the recipients of its services. Despite its not being succinct the three respondents to the questionnaire rated it as follows: one rated it below average and two rated it above average (table 4.3).

The respondent for institution E said that “...*our mission is to offer that excellence in business education for those who are academically qualified but may not have the opportunities to join public universities and yet they are financially capable of providing themselves education*”.

Among the documents obtained, the one referred to as the University Prospectus had a section captioned Mission and Objectives which was basically a statement of objectives of the university. The documents did identify the institution as having a bias towards business courses. However, the documents did not contain a statement of philosophy and the only values mentioned as espoused by the institution were the right to education for every individual, practicality and effectiveness. The services

and recipients of these services were not succinctly delineated either. The two respondents to the questionnaire, who were both involved in the development of the mission statement which was done during the time of the study, rated the institution mission statement as average (table 4.3).

Respondent to the interview for institution F articulated the mission statement as follows:

The mission is to provide Christian education to the constituency of the...(the denomination) in eastern and Southern Africa and others who can abide by the education conditions required by the University Council. The University has a primary responsibility to nurture the qualities of service both in the church and the community.

The documents obtained from this institution such as the bulletin, the student handbook and the staff handbook all contained the newly developed mission statement. They also contained the institution's statements of philosophy and objectives which are as follows beginning with the statement of philosophy (Institution F, 1995-1996: 8) (identity protected): *"That the institution recognises that God, is the creator and sustainer of the earth and the entire universe and is the source of knowledge and wisdom"*.

The objectives are categorised as follows, (Institution F, 1995-1996: 8):

- Spiritual - asking the students to rise to the highest level of personal satisfaction and success by accepting the goal of presenting to the world the gospel of Jesus Christ;
- Intellectual - urging the students to seek to develop as thoroughly as possible their intellectual abilities while recognising that the use of

knowledge is more important than its attainment;

- Social - encouraging the association based on self-control and on respect and loving concern for others;
- Vocational - encouraging the students to grow in work skills as they participate in worthwhile work opportunities on campus;
- Civic - seeking to enhance the students' devotion to the well being of their countries and to view the building of their countries as part of their responsibilities;
- Physical - encouraging the maintenance of vigorous manhood and womanhood for robust health.

The identity of the institution was mentioned in the documents and by the respondent, the proprietor of the institution, and the values espoused by the institution included quality, service to church and community, holistic development, self discipline, responsibility, tolerance, critical thinking, aesthetic taste and dignity of labour. The service was identified as providing Christian education but as a university it was not clear whether there was any emphasis on any of the three traditional university services - teaching, research, and community service. The recipients of the services provided were delineated as the members of the...(denominational) constituency in the region of Eastern and Southern Africa and others who could agree with the conditions of the university as set by the university council.

The five respondents to the questionnaire, two of whom indicated having been involved in the mission statement reformulation, rated it from average to above average, (table 4.3). Two rated it average and the other three rated it above average making the overall rating, according to this rating above average.

The respondent for the next institution G said: “...we are training Church leaders to lead the church organisations in Africa”. The respondent then proceeded to read the

mission statement which stated as follows:

We are a non-denominational graduate level theological seminary dedicated to equipping pastors, theological educators and a hierarchy of Christian leaders to help meet the needs of the fast growing African Church and help fulfil the gospel commission. The Church in Africa is growing rapidly and the African society as a whole is becoming more and more educated. So the mission is to serve the Church in Africa by training leadership and thus to contribute to the growth and stability of the Church.

The document obtained from this institution, titled the "Prospectus" (Institution G, 1995-1997: 6) (identity protected) also contains a statement of purpose which reads as follows: "The purpose of the...(name of the institution) is to build and train Christlike servant leaders who are equipped to help fulfil the Great Commission in Africa and in the world. Matthew 28: 18-20".

The prospectus also contained the educational objectives of the institution, commitments and a Statement of Faith. In summary, these statements are as follows starting with the statement of the educational objectives which comprise the attributes desirable for graduates from the institution (Institution G 1995-1997: 6-10):

- well-grounded in knowledge and understanding of the Holy scriptures;
- well-grounded in knowledge and understanding of the biblical doctrines;
- able to study and interpret the scriptures according to sound principles of biblical hermeneutics and correctly apply them to all of life;
- able to live a Godly life;
- able to effectively present the gospel in the power of the Holy Spirit in a variety of situations;



- able to nurture believers so that they can be incorporated into the church and grow towards maturity in Christ;
- able to take the truths of the word.
- able to respond with practical love and care to the people in society by ministering in loving compassion to their needs.

The statement of commitments include statements of commitment to evangelical doctrine; commitment to the building of character; commitment to cultural relevancy; commitment to academic excellence; commitment to ministry to student's spouses; commitment to ministry involvement by the academic staff; commitment to the local church and commitment to personal ministry training.

The statement of faith states that: "The sole basis of our belief is the Bible, God's infallible written Word.... We believe that it was uniquely, verbally, and fully inspired by the Holy Spirit, and that it was written without error in the original manuscripts. It is the supreme and final authority in all matters on which it speaks", (Institution G 1995-1997: 10-13).

The statement of faith appeared to be similar to what would have been the statement of philosophy while the commitments were synonymous to values which included evangelical doctrine, character, cultural relevancy, academic excellence, family life and partnership in Ministry, service to the local church and practical ministry training. The services provided are indicated as training and the recipients of the services are pastors, theological educators and church leaders in Africa. This institution identified itself as a seminary and therefore was a little different from the rest of the institutions studied. The only respondent to the questionnaire who also was one of the authors of the mission statement rated it as average (table 4.3).

The respondent for institution H said:

Our mission for the university is in a way the mission or the co-mission given to the Church by Jesus Himself as in Matthew 28: 19-20....The teaching here is within the context of the gospel commission. We have to educate people about knowledge about God or of God....There is an interrelationship between the commission and the mission which is to be able to tell people about God in our various ways of learning so that they can see the love of God in all the courses.

The actual wording of the mission statement was being revised during the time of study. The following was the draft of the revised mission statement provided:

The...(name of the institution), as a...(name of the sponsoring denomination) institution of higher learning, sees as its mission the advancement of the teaching and people-reaching ministry of Jesus Christ such as would facilitate the proper mental, spiritual, physical, and social development of its faculty, staff, students and administration alike.

The statement then further itemised the means through which its various academic and service departments seek to accomplish the mission statements while stressing relationships between the following attributes and values: availability and affordability, thinking and commitment, learning and living which is practical knowledge, worship, work ethics and service.

A statement of philosophy is contained in most of the documents of the institution, which also give the identity of the institution by identifying the proprietor of the institution in the statement. The statement reads as follows: "The university holds a Christian philosophy of life and expects all its members to conduct themselves in accordance with the tenets and principles of that philosophy as part of the basic affirmations of the...(name of the founding church body). The statement of mission, however, does not clearly indicate the services the institution offers in the course of advancing the teaching and people reaching ministry as a university. The recipients of the services were not delineated either besides mentioning faculty, staff, students and administration.

The five respondents to the questionnaire, who indicated having known the institution's mission when they first became associated with the institution and were all involved in its review, rated the mission statement from below average to average, with only one respondent rating it above average (table 4.3).

The respondent for institution I gave the mission of the institution as: "*...the development of servant leaders and the expansion of education in Africa. To produce people who love their countries*".

One of the documents obtained which was the University Charter contained the mission of the university in two parts that, (The University Act 1994: 914) (identity protected)

...the Mission of the university shall be:

- (a) to provide Christian-based higher education, training and research for the expansion of God's kingdom in the world, and especially Africa;
- (b) to provide broad biblically based education programmes that will develop men and women to serve in a variety of supportive and leadership roles in the African Church and society, and through the training and extension programmes, research and advisory services, to help equip the Church to effectively service the society in which it exists.

The document also contained a statement of philosophy of the university, commitments which were synonymous to values espoused by the university, and the objectives of the university.

The philosophy statement states that (University Act 1994: 914, 915):

The...(university) Christian philosophy of life and conduct, teaching, training and research is founded on Christian principles and values based on the

following biblical statement of faith and practice. As a community of people who follow Christ, we:

- (a) Affirm our belief in -
  - (i) the one eternal God...the Father, Son and Holy Spirit, the creator and Lord of the world, who governs all things according to the purpose of His will...;
  - (ii) the one saviour, Jesus Christ...;
  - (iii) the Holy spirit...;
  - (iv) the divine inspiration, truthfulness and authority of the old and new testament scriptures as the word of God with power to accomplish his purpose of salvation;
  - (v) the return of Jesus Christ personally and visibly in power and glory to consummate his salvation and judgement.

The commitment statement states that the university is committed to (University Act 1994: 915, 916):

- (i) the church of the community of God's people that is not identified with any particular culture, social or political system or human ideology;
- (ii) the Christian churches that are deeply rooted in Christ and closely related to their cultures tested with scriptures' criteria for truth and righteousness;
- (iii) the freedom of thought and conscience to practice and propagate the gospel in accordance with the will of God, and to remain faithful to the gospel whatever the cost;
- (iv) the sharing of God's concern for justice and reconciliation throughout human society and for the liberation of man;
- (v) Christian education, training and research that are indigenous and developed by the creative local initiatives according to biblical standards of doctrine, discipleship, evangelism, nurture and service.

The objectives are listed as, (University Act 1994: 916, 917):

- providing resources for university education... within the context of

Christian truth and commitment, spiritual sensitivity and obedience to Christ;

- providing, with other Christians, academic leadership to the church in Africa;
- providing adequate resources for quality university education reflecting the African culture;
- developing in students deeper faith in Jesus Christ and greater commitment to His people;
- guiding the students to understand and accept themselves, their individual needs and the talents, and to develop their potential for productive life and service;
- providing the students with a balanced educational programme that helps them to develop and to broaden their perception of the inherent inter-relationship between the physical and spiritual needs and to develop a holistic approach to life;
- equipping student to personally commit themselves to evangelism, church planting and leadership;
- developing in students a deeper understanding of traditional and modern Africa; and
- playing an effective role in the development and expansion of Christian education in Africa.

The values espoused include the community of God's people, moral absolutes, freedom of thought and practice while remaining faithful to the gospel whatever the cost, justice and reconciliation, creativity of local initiatives in accordance to biblical standards. The mission encapsulates the philosophy by endeavouring to expand God's kingdom which according to the institutional philosophy is the underlying aim of Christianity. The identity as portrayed in the mission was that the institution was a Christian university. The services provided were identified as training and research

and these are available primarily to Africans and then to all others from all over the world. The mission was, however, given in form of objectives more than a mission statement.

The four respondents who completed the questionnaire, three of whom had become acquainted with the mission of the institution when they first became associated with the institution and one having been one of its architects, rated the mission statement as below average, to above average. One's rating yielded a below average score while the other three yielded an above average score (table 4.3). The respondent who was one of the architects of the mission statement was the one whose score yielded an average score.

For institution J the respondent gave the mission statement:

To give education to African young people of the Church in line with the mission of the Church which has got the duty of preaching the gospel. The Church is also concerned about the growth - the general growth of the human being and encourages the spiritual, mental and physical development.

The respondent expounded on the mission by referring to the following statement of objective: *"to develop students for effective Christian living, in other words we would like to train people or to develop for the leadership of country people who have a Christian lifestyle"*.

Among the documents obtained from the institution the proposal for establishment of the university submitted to the Government had an elaborate statement of philosophy emanating from that of the sponsoring church and stating the basic belief in education in a quotation that "...there is no conflict between the best in education and the best in the Christian faith", by one of the Church education leaders and that the expressed philosophy of education is "...quality education with a Christian purpose".

There was, however, no formal statement of mission in written form. Instead the institution had a brief statement that the mission of the university is "...the development of Christian character within a philosophy and framework of genuine scholarship", an outline of how the university seeks to achieve the mission and a statement of aims and objectives as follows, (The Working Committee Of Institution J, 1991: 1, 14-21):

- By providing a Christian community of scholars in which the faculty is expected to follow a life rooted in Christian values, pursue excellence of intellectual training, seek the integration of faith and learning, instruct students effectively, and contribute to the world of scholarship.
- By the integration of Christian perspective of life as summarised in the Scriptures that "Seek ye first the Kingdom of God" into all aspects of the institution.
- By offering guidance toward a world view consonant with both reason and revelation, and encouraging attitudes of mind and standards of judgement consistent with Christian teachings to enable the student to play an effective role in building a better social order.
- By enabling the student to acquire a clear understanding of Christian beliefs and values and the ability to interpret these to others, and to develop a sense of obligation with respect to applying Christian principles to contemporary socio-cultural problems.
- To develop students for effective Christian living. Believing in the dignity of human life, the institution endeavours to:
  - provide education for ministers and laymen who are committed to the moral values and ethical priorities of a distinctively Christian perspective;
  - creating and maintaining an environment conducive to development of mental, spiritual, physical and social growth;

- equipping the students with knowledge and skills to enable them to be self-sufficient and practical in every respect;
  - developing the students' personal capabilities and to sensitise them to intelligently and effectively communicate to others their life values and concepts;
  - training and producing teachers to staff various educational institutions and by life and example lift the quality of life of students and those whom they serve;
  - providing post-secondary education by offering university courses leading to the granting of certificates, diplomas and degrees;
  - providing an education of academic excellence at an affordable cost;
  - instilling in the minds and philosophy of students a respect for non-white collar jobs, emphasising honest labour of any type is honourable
  - helping the students to discover the truth that every young person has the right to become a whole person.
- To develop a community of scholars by endeavouring to:
    - employ qualified staff and provide them with opportunities for personal academic development;
    - promoting scholarship by challenging students to search for truth and solutions to the major problems of society;
    - providing resources and programmes for research devoted to seeking solutions for social and national problems;
    - providing adequate facilities, equipment and time for teaching and research;
    - providing directly or in collaboration with other institutions of higher learning, facilities for university education, including those technological and professional fields determined by the trustees of the university;
    - rewarding academic excellence in teaching including open-mindedness, objectivity, persistence, courage, a thirst for knowledge and the capacity to



arrive at sound judgements.

- To develop graduates for leadership service, by endeavouring to:
  - focus on community and national needs in the courses both by content and by assignments;
  - provide motivational training to challenge students to become involved in community and national service;
  - participate in the discovery, transmission and preservation of knowledge, thereby stimulating and encouraging the ethical, intellectual and cultural development;
  
- To develop appreciation of African heritage, by endeavouring to:
  - arrive at an informed and analytical view of the historical, cultural, social and other forces which mould individuals and nations;
  - develop a sense of stewardship regarding the students' nations natural resources;
  - gain a knowledge of rights and obligations of management and labour;
  - to become aware of the transitions taking place in contemporary life;
  - to address the contemporary issues of both the Christian faith and sound government;
  - to become involved in a lifetime of stewardship of service in helping people;
  - to be opposed to discrimination on the basis of race, denomination, gender, or irrelevant handicaps.

This, as observed, was elaborate and contained the values the institution espoused, which include the dignity of human life, moral and ethical priorities, self-sufficiency and practical life, honest labour, love for the truth, open mindedness, objectivity, persistence and courage; and the means the institution hopes to use to achieve them. If fully implemented the institution would probably become the best example for

emulation by other institutions of higher learning. The statements further identified the institution by referring to the proprietor as the source of the philosophy for the institution. The services provided as a university in preparing the students for effective living were, however, not succinctly defined but the recipients of those services were generally delineated as African young people of the Church.

There was no response to the questionnaire for this institution so the rating of the mission statement was not obtained.

The respondent for institution K said that the institutional mission was the motto of the university which was "...consecrate them in the truth, John 17: 17."

Among the documents obtained from the university was the University Charter but this did not have a statement of the mission although the same motto was expressed. It instead had the statements of philosophy and objectives of the university. The new chief executive of the institution had explained that on assuming that responsibility, no written mission statement could be located among the documents of the institution. The mission statement that had been recently developed was obtainable on a one page document entitled "The Mission of...(name of the university)" (Institution K, 1997 : 1) and it is stated as follows:

The mission of...(name of the university) is based on its motto: *'consecrate them in the truth' John 17: 17.*

As a centre of an academic community of scholars: both lecturers and students, the main aims (objectives) of the...(name of the university) are:

1. To discover, preserve and impart the truth in all its aspects and in its essential relation with Supreme truth who is God through academic endeavours and scientific research.
2. To play a fundamental role in the integral formation of human person and the family in AMECEA region and in Africa at large.
3. To be faithful witness of the Christian message as it comes through the

word of god, the...(name of sponsoring Church) tradition and the *Magisterium* of the Church.

4. To promote contact and cooperation with other member Universities so as to share any acquired body of knowledge with all academicians of good will and together foster a nobler human society.

The philosophical basis of the university and its identity were interwoven in the above statements by identifying the sponsoring Church, referring to its tradition and its holistic approach to nature, humanity, and God. The values espoused by the institution included preserving truth, integral formation of the human person and the family, being a faithful witness of the Christian message and wholeness as human persons. The basic services included all the three traditional services of universities - training, research and community service, although they were not defined in the mission statement. These were expounded in the functions of the university without mentioning any emphasis among them. The recipients of these services were not delineated in the mission statement.

There was no rating for the mission statement of this institution either because none of the questionnaires was returned or because the institution had just developed a mission statement.

The respondent for institution L said:

The mission of the university is to provide education of high quality to nurture students in Christian values and to help the nations of Africa achieve their educational and professional goals.

The documents obtained from the university, except the Charter of the University, contained the mission statement. Apparently when the charter was drafted for approval by the Government the current mission statement had not yet been finalised, like the metaphor of the chicken and the egg. The charter, therefore, did not contain

the statement of mission although the respondent further elucidated the mission statement as follows:

Education is the fundamental means of fulfilling individual needs and personal development, achieving the goals of society, and advancing culture and economy. The mission of the...(name of the institution) is to provide higher education of high quality, to nurture students in Christian values, and to help the nations of Africa achieve their educational and professional goals. ...(name of the university) will play a critical role in educating the new leadership of African nations.

The charter, however, included a statement of the university objectives as follows (Institution L Act 1992: 119):

- to preserve, transmit and enhance knowledge for the benefit of the people of Africa...;
- to empower students to enhance the formation of their fundamental capabilities, and assisting them to think critically and to be skilful in communication and methods of inquiry;
- to create a sense of public responsibility in the students and to promote respect for learning and pursuit of truth and mature thinking about the ultimate meaning of life;
- to encourage perspectives and moral values embodying a sense of vocation, a deep concern for human betterment, an obligation of service to others, equality among persons, loyalty to the truth and responsible citizenship;
- to develop and promote leadership with moral character and instilled with a sense of care and responsibility to all;
- to stimulate and promote cultural development, interpersonal

- relationships and international understanding among the students;
- to promote an understanding of practical application of knowledge including historical origin, purpose and meaning of life, a sense of value to life, a balance of intellectual and spiritual health, identity and African culture, and integration of various cultures.

No statement of philosophy or philosophical basis for the institution's mission was included in any document and the institution the identity was not clearly indicated in the mission statement. The values espoused by the institution were generally referred to as Christian values but with exception of high quality, no other values were explicated in the mission statement. They are, however, articulated in the objectives as seen above and include critical thinking, public responsibility, respect of learning, pursuit of truth, concern for human betterment, service to others, equality among persons, responsible citizenship, practical application of knowledge, balance of intellectual and spiritual health, identifying with African culture, and integration of various cultures. This array of values may be what was referred to as Christian values in the mission statement.

The mission statement did not delineate the services the institution provides as a university between teaching/instruction, research or community service in providing high quality higher education. The recipients of this service were not delineated either, other than stating African nations.

Among the four respondents to the questionnaire from this institution, three of whom had become acquainted with the mission of the university when they first became associated with the university and one was involved in its development, two respondents rated the mission statement as below average and the other two rated it average (table 4.3). It could, therefore, be rated as generally average.

The different faculties and schools of this institution had developed their own mission statements some of which apparently were more succinct but in keeping with the general university mission such the one below for the Faculty of Theology (Institution L 1997: 1):

The Faculty of Theology of...(name of the university) is a community of learning whose purpose is to educate men and women to be `servants of Christ and stewards of the mysteries of God for the churches of Africa. The faculty is committed to excellence in teaching and research where an understanding of the Bible's transforming and prophetic message is central. Students will gain knowledge and understanding of God's mission in today's Africa and the world. Generations of teachers will be prepared to teach Church leaders across the continent through pastors' schools, continuing education programmes, and correspondence courses. The faculty of theology, related through the university to the...(name of the denomination) Church, welcomes into its community persons of other churches, celebrating the unity in Christ through theological study.

This mission statement identified the primary services as teaching and research, and delineated the recipients as African who espoused the same beliefs and others who celebrate the unity in Christ. Its identity is stated in the first statement: "The Faculty of Theology of...".

In summary the mission statements studied represented a variety of types also referred to as a divergence of approaches to mission statement writing by Strydom (1989: 62); and a fair degree of what Detomasi (1995: 31) and Davis (1986: 105) refer to as vagueness that characterises many university mission statements. Nevertheless all respondents avowed that mission statements were essential in the management of institutions. The process for the development of the statement is one way to assess the

commitment to this claim by university managements. There was not much argument about autonomy and self-management of the universities which is usually a major argument within universities (Saint 1992: 71-72).

#### *5.2.1.2 Types of Mission Statements*

Using the classification of mission statements suggested in section 2.7.2 none of the mission statements for the institutions studied could be classified among the messianic or the anthology categories. They were mainly a mixture of the remaining types with more inclination towards the historical-philosophical type. This was probably so because many of the institutions needed to justify their existence from historical and philosophical points of view. Statements such as “Our mission for the University is in a way the mission or the co-mission given to the Church by Jesus Himself in Matthew 28: 19, 20... We have to educate people about the knowledge of God” is an example of this kind of inclination by its reference to the commission of Jesus. The following connotes the same inclination: “The mission was to help people to have and understand their faith and to live as Christians in their local environment and also to be effective and change their environment. It was to make disciples for the Church as in the great commission in Matthew 28: 19, 20”.

The term “excellence” was also used in one mission statement for institution L. This is usually used in mission statements of institutions which are heavily oriented toward the process of consultation. Other terms used included “*provision of functional education*” by institution A, “*imparting truth*” and “*integral formation of human being*” by institution K, and “*expansion of God’s Kingdom on Earth*”, by institution I. These are terms which are not easy to assess particularly for institutions which had only been operational for relatively a short time and were undergoing internal and external management changes. In summary, therefore, most of the institutions’ missions for the institutions studied endeavour to justify their establishment from a

historical perspective that they are fulfilling the commission of Christ which is also the basic philosophy of most of the Christian religious institutions.

### **5.2.2 Mission Statement Development**

In this section responses on the process of developing or formulation of mission statements by the various respondents are presented and discussed. Like the articulation of mission and mission statements themselves, there is little agreement on the process for formulation of mission statements in literature.

Respondents had various opinions on the development of mission statements. The respondent for institution A said that *"...a small committee of about three members of staff was appointed about four years ago and they developed a rough draft of the statement which was presented to the general faculty assembly, and gradually it was sifted until it was ready to be presented to the board or university council for approval"*. The final approval was vested in the board but according to the respondent, *"...the initiative came from the faculty of the university"*. The council made some minor expression changes but the bulk of it remained the same.

For this institution the process, which had been started as the institution began to upgrade to a recognised university, involved the faculty. No other group of stakeholders such as students, was cited to have been involved.

Two of the three respondents to the questionnaire from this institution affirmed this involvement while the other one who was relatively new to the institution but had seen the statement did not know who was involved in its development.

For institution B the respondent said that *"...when the university was established just before its opening in 1992, a committee of eight bishops or their representatives*



*developed all the statements*". For this institution apparently the mission statement was passed on down to the institution by a committee of bishops. There was no mention of involvement of the faculty or staff although the respondent indicated that the committee had the liberty to coopt other persons. "*Everything was done through the committee which had the power to coopt other members*", the respondent said.

The only respondent to the questionnaire from this institution who was relatively new to the institution had not seen the mission statement and did not know who was involved in its development. This institution had only part time lecturers at the time of the study.

Institution C had no written mission statement. So the respondent could not explain the procedure for its development.

For institution D the respondent answered this question by saying that "*before the inception of the university there was a committee of a number of people including people from various dioceses who helped to develop the charter by organising the opinions*". For this institution whose mission was not in any documents of the institution, all the committee dealt with was the draft charter. The committee itself did not include members of the faculty or students since these were not in place yet. Responses from two respondents to the questionnaire affirmed this by indicating that the process involved the founding body and the university council.

For institution E, which evolved from a commercial school to university status, the respondent said that before the change to university status, a steering committee was appointed and "*charged with designing the mission statement which was then sold to the trustees and approved*". That committee was formed out of the board of governors who were themselves appointed by the trustees as was indicated in sections 4.2.2.1 and 4.2.6.2.

There was no involvement by the faculty, some of whom were already there serving the institution in a different capacity as well as by the then commercial college students. The two respondents to the questionnaire from this institution seem to suggest otherwise, that there was involvement by faculty, administrators, the governing body and the founding body. This may be indicative of the misunderstanding of what the mission statement may really be although the institution may have a mission it is endeavouring to accomplish.

The respondent for institution F stated:

It answers the questions who we are, what we do, for whom and with whom. This statement of mission has evolved over the years including discussions within the university leading to its (the university's) recognition.... It has been discussed by faculty and administrators. It has been to the (governing) board several times being read by the Chancellor to the board. Although the board has not taken a formal action on the mission statement as it is now enunciated, we operate basically on the understanding of that mission statement. What the board now requires us to do is to have it worded succinctly. The mission statement therefore is coming out of the guts of the university and finally given form by the faculty and administration, We pay special attention to the wording-that every word has got reason for being there.... It is a statement that has been carefully thought

The above explanation of the process indicates that this institution has taken time to come up with a mission statement by involving faculty, administration and the board, although it has not yet been formally approved. This happened as the institution sought recognition by the Government. Because of this process it was possible for the respondent to articulate the mission of the institution. The same was affirmed by three of the respondents to the questionnaire who indicated that faculty, administration and board were involved in the development of the mission statement. One respondent who was relatively new to the board of the institution indicated that it was developed by the board and also remarked that it should always be so.

For institution G the respondent stated: "*We developed this mission statement as a requirement for the Commission for Higher Education otherwise we have always had a purpose statement*". Those involved in its development according to the respondent "*...were the staff council, specifically, the principal, the faculty and some other administrators*". However, the original draft came from "*...the founding body*".

For this institution there was some involvement apparently, in discussing the founding body's draft of the mission statement although not very elaborate. This was also affirmed by the only respondent to the questionnaire who also indicated involvement of the staff, administration and founding body/board.

Respondent for institution H, who was a relatively new chief executive of the institution, stated as follows:

I have tried to trace its (the mission statement's) beginning and as an official statement it is a recent statement of about three to four years but as unwritten philosophy it is as old as this university. I know this since I have been associated with it (the university) from the very beginning and I happen to know that the mission of the institution has not changed. It is only that it had not been written down. In fact as I see it now it is not yet in its final form. I think we still have to refine and fine-tune it so that it can be crystallised in a much shorter way.

This respondent, who was about one year in the position of chief executive of the institution, did not know who had been involved in the formulation of the mission statement three to four years before assuming leadership of the institution but added that "*...the faculty and administration should be fully involved probably through a committee process which would examine it periodically and make recommendations to the senate and general faculty assembly*".

This respondent acknowledged the need for involving the faculty and administration but appeared to suggest a standing committee to continuously review the mission of

the institution.

The responses from the questionnaire were varied although four of the five respondents indicated that faculty, administration, founding body, and governing board should be involved. One of the four also included the students in the list and one did not respond to this question.

The respondent for institution I said the mission was basically the same since the inception of the institution but had evolved over the years just as the institution had evolved from a publications company to a communications and research institution to the recognised university which it is now. The respondent referred to the founders as having been the first to develop the mission statement which was then taken over by the board, later the university council as *"...key developer of the mission statement. The current wording, not the core mission, was developed with the involvement of staff and students in retreats and seminars"*.

This was another example of a mission which has evolved over the years but later taking cognisance of the need for involving staff and even students. The entire process was not explained, however. The four respondents to the questionnaire were varied in their responses although they all indicated that there should be involvement by faculty, administration and governing council.

The respondent for institution J only stated that the mission came from the Church and it is the same as for all other universities of that Church. Although this institution was only three years old at the time of the study there was no mention of involvement in developing any mission statement and none was found in any of the documents except aims and objectives.

Another mission statement similar to the one above developed by the founding body

was the mission for institution K which had only recently been put in writing according to the respondent who said that the mission statement was developed “...since the inception of the university but was put on paper only recently”. The respondent added that “...it was developed by the Association of Member Episcopal Conference of Eastern Africa (AMECEA) committee”. There was no indication of any involvement by the faculty or even the administration and the council except by membership of the chief executive and senate representative on the AMECEA committee.

For institution L the mission statement was developed, according to the respondent, by the Board of Directors about a year before the University was established. Three of the four respondents who responded to the questionnaire affirmed this response by indicating the founding body/governing board as having developed the mission statement. One indicated the staff as having been involved.

The responses to the question about mission statement development and to the one of what the mission statement actually is both in the interview and the questionnaire were somewhat divergent indicating some diversity of understanding of what a mission statement is supposed to be and how it should be developed. This may further be due to lack of involvement by many of the respondents in its development. This is contrary to what Strydom (1989: 43, 44) suggests that “...obtaining as many view points as possible from the concerned people inside the university regarding a particular matter promotes the reliability of the mission” and that “active involvement enhances the quality of the mission as well as its eventual implementation through strategic planning”.

Closely related to the development of a mission statement is the idea of revising it. The next section contains responses on the practice and the respondents’ thinking about reviewing and the reformulation of a mission statement.

### 5.2.3 Mission Statement Reformulation

Since a mission statement can be regarded as a document of principle and as a directive document, Strydom (1989: 46) argues that regular reflection on its directive value is essential. This section, therefore, presents and discusses the responses on this subject.

The respondent for institution A began by stating that “...*mission statements are dynamic by nature as the institution grows depending on the needs of society and the Church so we may make some adaptations. In fact we are having another look at it right now and we may make some changes to it*”. The respondent said that there is no set time for such evaluations but it takes place as changes and needs occur. Another respondent representing institution H, who used the same term said: “*I think the mission statement should be dynamic. Dynamic in terms of probably the wording but the substance remains the same...*”. This respondent then added that the current mission statement was not in its final form but was still being fine-tuned.

Other respondents seemed to argue similarly although not using the same term. They made statements such as

“The basic principle will always remain the same but the application may change such as with the changing status of the university”;

“As we develop there is that open-endedness. The board of trustees have vested the power in the university council to be able to design what the market wants”;

“We have kept refining it. It has come up many times in our evaluation team”;

“The basic mission of the university will not be revised but as the university continues to develop its (the mission’s) wording may need to be revised”;

“It should be revised if it is getting out of date but the university here is very young so we have not had any revision yet”. This respondent for institution J added that “people should review their objectives and if they find that there is a need to restudy them they should do so”.

The above responses suggest that it is important to review the missions of institutions since they are dynamic and need to match with the circumstances. Most of them, however, indicate that the core mission of an institution remains the same.

An elaborate respondent representing institution F said that their institution’s current mission statement had been revised in the previous two years considering the institution’s recent recognition by the government. The respondent said: *“This focus is coming in the last two years since we are standing alone as a university, we need to spell out the university programmes. We have a preponderance of undergraduate programmes but now our vision is that both undergraduate and graduate programmes will be offered.... So we are constantly fine-tuning the mission statement.... The changing needs of the constituency affect the direction and fine-tuning of what we are doing so that the mission statement helps us to keep in focus”*.

According to the respondent for institution C , however, the mission statement does not change easily, expressed in the following statement: *“It (the mission statement) is set because it arises from the statutes of the university. These were discussed by the Islamic Conference and the Government...and passed by the parliament.... So mission cannot be changed easily”*. This was despite the absence of the written mission statement in the statutes.

The respondent for institution B simply said that the mission statement had not been revised but expressing the need for such revision, while another indicated that it had been revised four times already.

Like the rest of the answers on mission statement, this also showed some divergence in responses although there was more agreement on the need to revise the mission statement with changing circumstances. This is in agreement with what Arth *et al.* (1987: 20) state that “On a regular basis, the impact of the statement on the school’s operation should be assessed.... It is important that this assessment be conducted on a routine basis. If not, the mission will lose its vitality and become yet another document that no one pays much attention to in daily operations”. Although this statement is made in connection with middle level schools (Arth *et al.* 1987: 1), it should apply to tertiary institutions as well.

#### **5.2.4 Mission in the Practical Life of an Institution**

Referring to daily operations in section 5.2.3 above the mission statement should be applied in practice in what takes place at the institution. Campbell and Yeung (1990: 23) contend that “Mission statements have become a tool of management”, now getting more attention in strategic management and are believed to help clarify management thinking and improve communication in an organisation, which are very important in management including management of tertiary institutions.

The following is a presentation and discussion of a respondent’s observations as to how the mission statement is seen and applied in practice.

The respondent for institution A said:

...our institution is a Christian institution operated by the...(name of the



Church). We try as much as possible to recruit from the Church. Most of our members of staff would be members of the Church and would have a world view that puts God at the centre of the education system. Since these men are very influential when it comes to development of a philosophy or a mission we are satisfied to the extent that the mission is consistent with the view of the owners of the institution and the overall world view of the Church.

For this institution priority was placed on recruitment of personnel including administrative personnel who are the key in implementing the mission of an institution. In addition, the curriculum developed according to the same respondent for institution A “...puts God at the centre of everything we do here”. The institution has courses offered to all students which include religion.

...every student does 14 quarter hours of religion courses as part of their requirements. The idea is not to turn them into Christians by force but to infuse some of our value systems into them. We also try to integrate faith and learning and by that expression we think that all knowledge and truth is God’s truth so we should not have a sharp line between what is secular and what is God’s but the two can be integrated.

The idea of having included in the curriculum some religion courses as a means of translating the mission into practice also surfaced among some other respondents. The respondent for institution B said:

Each student takes some religion courses. First year students must pass these courses and while a student may be compensated for failure in other subjects, for these subjects the student must pass. We don’t allow compensation. In these courses we do not emphasise doctrine but the approach to issues of social concern...and we try to inculcate Godly values, attitudes and Godly beliefs.

The respondent added that since the institution had not yet graduated any students they were not yet in a position to judge how this practice, affects the students’ lives when they leave the institution. The institution only had received reports from the places where the students studying business subjects had done their attachment and the teachers had done their teaching practice. The reports according to the respondent

were good.

Respondent from institution D emphasised the inclusion of ethics in the curriculum *“That is the reason why we started a course in ethics so that in the context of other professional courses such as Agriculture, Business, or Science we may be able to produce students who are responsible and ethical. All courses have a course in ethics regardless of the discipline”*. The respondent gave no guarantee of transforming students lives stating that *“You can not guarantee that the students’ lives shall be transformed”*.

For other institutions, Christian courses were presented in addition to other practices in the institution that help to translate the mission statement into practice in the life at the institutions. A respondent for institution I started by stating:

We are in every way Christian and even our charter recognises it although it was originally difficult to convince the government that we are different. They wanted us to be just as open as any other public university but we wanted to serve the Christian community even in admissions. Eventually they (the government) allowed us and it can be seen in our charter. We don’t take any particular creed so we removed that from our non-discrimination statement. However, membership is limited to those who profess Christianity or personal faith in Jesus Christ.

The respondent then added that the general education program has 18 hours of *“...Christian courses which are compulsory”*. In addition, this institution has mandatory chapels for both students and staff and the institution conducts Christian fellowships. There are also voluntary outreach programmes in which students are encouraged to participate. The respondent further added: *“We have an orientation week to assess the spiritual maturity of the new students. Programmes are organised for those who are found to be immature”*.

Respondent for institution D said:

We have a three quarter hour course on Catholic Social Teaching, also referred to as Christian Social Ethics which was approved by the university council to be taken by all students. The Commission for Higher Education was concerned if we were not imposing Christianity on the students but all students who come here come with advance knowledge of the uniqueness of the university.

In addition, the respondent said that the institution has chaplaincy and counselling services and the approach to everything in the university including sports, has a Christian touch. The emphasis in sports is on “...*cooperation and not competition*”. There are also several Christian associations and other associations. In all these associations honesty is emphasised as a very important virtue.

The respondent for institution H stressed the implementation of mission and goals as important saying that the administration “*must have a sharp focus of where they want the institution to go*”. The next thing according to this respondent is to mobilise the faculty to see how they can make practical the goals and objectives that have been set up for the institution. “*If they (the administrators and faculty) are committed then they should bring the goals to reality*”. In terms of the students the respondent argued that “*...we endeavour to see to it that as many of the students are of our constituency (referring to those students from the same religious persuasion as espoused by the institution) as possible. This makes it easier to implement the policies*”.

The respondent then continued that the institution does have “*...courses such as Christian beliefs which are compulsory to all students. Unfortunately*”, the respondent added, “*...we have not enforced these courses as part of the first courses in the students studies here*”. It was the respondent’s conviction that these courses should be presented as first year courses to avoid them being taken at the very end just to fulfil graduation requirements in which case they may lose their importance in as far as the mission of the institution is concerned.

The respondent for institution F began in a similar vein by stating that the mission is translated in action by “*...ensuring that the constituency gets preference*”, adding that

...we try to have a total atmosphere that is Christian, by having Christian administrators, faculty and students. As for students, however, we have a variety coming but we give first preference to Christians. As for teachers we pick, not only Christians, but members of ...(name of the Church) as far as possible, because these are the people who are responsible for modelling the Christian world view among the students.

This respondent made no reference to whether the institution has any religion or Christian courses in its curriculum as part of the effort to put the religious mission in practice.

For institution G, which was basically a seminary, the respondent referred mainly to evangelistic programmes as the means used to translate the mission of the institution into practice, adding that *"we practise what we teach"*.

A respondent representing institution J said that the institution was a university of a Christian Church and therefore did not allow the *"...taking of alcohol and smoking by both the students and staff"*, adding that *"...those are some of the things we don't compromise on"*. Another respondent representing institution C simply referred to the dean of students who working according to established Shariah (Islam law) committee is responsible for the behaviour of students to ensure they are behaving according to the required standards. This respondent added that *"...the university was set up to promote and protect Islam civilisation and culture in the English speaking countries of Africa"*. So the university offers programmes with the aim of showing the students the stand of Islam on various social issues which they do not call indoctrination but *"Islamisation of knowledge"*. The respondent added that *"...we also encourage the students to observe the Islamic religion as much as possible"*.

Only one respondent representing institution L was rather liberal in the response regarding translating the mission statement into practice stating that, according to the institution mission, the goal was to achieve academic excellence, adding that *"...this*

*is our Christian commitment.... We invite anybody who can assist us to achieve this goal. Certainly if there are those among us who are not Christian we persuade them to become so... ”.*

In responding to the issue of mission in practice, there appears to have been an over-emphasis on the religious commitment part of the mission and the inclusion of religious courses by most institutions. While that may be appropriate to emphasize the uniqueness of these institutions as religious ones and may have arisen from the historical background of most of the institutions having begun as seminaries it may engender a perpetuation of the same seminary spirit and approach to university education. Some of the allegations levelled against some of these universities is that they operate like seminaries. Few institutions studied referred to general behavioural standards in line with their missions as universities or other none directly church related values which are expressed in their missions. The emphasis was on what the institution does to enforce the mission rather than the outcome of that enforcement in the life of the institution.

### **5.2.5 Dissemination of Institutional Mission**

Practical application of mission is one way of disseminating the mission statement. This presupposes that it is known by the stakeholders and their involvement in its development. Furthermore, in outlining the mission statement development procedure, Strydom (1989: 45) lists communication before, during and at conclusion of the process as an integral part of the process asserting that the mission has no value if it is not introduced to the various interested parties in an appropriate manner. Similarly, Arth *et al.* (1987: 19), contend that the final draft of a mission statement should be disseminated as widely as possible and its implications discussed by faculty and students.

Among the institutions studied, only a few respondents alluded to this happening in their institutions as borne out by the respondent representing institution F: *“It has been to the board meetings, being read to the board members on several occasions”*. In this same institution, the other one being institution L, the mission statement could be seen in many of the institution documents and a few copies were conspicuously displayed on some notice boards in the institution.

The absence of the mission statement in some of the other documents for the other institutions studied as already indicated in section 5.2.1.1 appears to have been more of a multiple interpretation of what a mission statement should be rather than a total absence of one.

Responses to the questionnaire indicated that whatever the respondents regarded as their mission statement was fairly disseminated. Only one respondent to the questionnaire from institution B indicated not having seen the institution mission statement. The rest marked having seen what the institution referred to as the mission statement although there was divergence of responses as to which documents contained the mission statement even in a single institution. The commonest documents which contained the mission statement according to the responses were the institutional charters, and the students’ handbooks; and the least commonest was the teachers’/faculty handbooks. This may imply the mission statements are used for purposes of accreditation when they are put in the charters as well as for the guidance of student behaviour more than anything else when included in the students’ handbooks.

Besides mission statement being expressed in the documents, if there is agreement and commitment to the mission statement it should be spoken about and referred to when making institutional decisions even in the classroom. The conditions of agreement and commitment are important since they are the prerequisite for what Laramée (1987: 19) refers to as communicating the institutional image. In a similar sense Campbell and Yeung (1990: 22), in their guidelines for managing mission, wrote that public statements of mission can generate cynicism and disillusionment

when they do not reflect reality. This refers to cases where they indicate things that are supposed to be happening, however, being far from reality and no effort is being made to change towards that. In such cases they make employees cynical about the leaders. They argue that published mission statements are most useful when they document the existing mission of the organisations (Campbell & Yeung 1990: 22).

Out of the thirty one respondents to the questionnaire three rated the level of commitment to their institutional mission by the faculty/teachers as being below average. The rest rated it to be average and above.

### **5.2.6 Mission and Institutional Curriculum**

Relating curriculum and mission is likened to the “chicken and egg” scenario according to Vaughan (1984: 27). He states that ideally the curriculum should be a means of carrying out the mission of an institution but often changes in curriculum significantly shape the mission.

Since one of the key functions of a university is teaching/instruction (Strydom 1988: 3; Wolpe 1995: 276), mission statement and curriculum should have an important relationship. Just like the “chicken and egg” situation may prevail in institutions of higher education, the question of who designs the curriculum is also important. In section 5.2.4 it has been alluded to that one of the most common means of practically emphasising missions of institutions has been by introduction of religious courses into the curriculum. It remains to be seen how religion influences the entire curriculum. This could be in terms of the core curriculum or in the approach to teaching and ideologies also sometimes referred to as “isms”.

### 5.2.6.1 Core Curriculum

As already indicated in section 5.2.4, besides the seminary whose courses are basically totally religious and the non-religious institution, most institutions studied avowed offering religious courses in the curriculum as a means of translating the mission of their institution into practical life in statements such as: “...every student does 14 hours of religion courses as part of their requirements”; “Each student does some religion courses” and “...the general education program has 18 hours of Christian courses which are compulsory”. For these institutions these courses appear to form part of the core curriculum although the number of hours varies from 4 to 18. Other institutions attempt to camouflage these courses by terms such as “ethics”, “Christian Ethics” or “Christian Beliefs”. Two institutions indicated not having any religious courses in the core curriculum.

The core curriculum of these institutions contains religion courses which at times is a source of contention with regard to religious and academic freedom (Fisher 1989: 99). Two of the institutions also mentioned the idea of integration of faith and learning as an integral part of the curriculum. The respondent for institution A said: “*The curriculum we have developed puts God at the centre of everything.... We try to integrate faith and learning by which expression we think that all knowledge and truth is God’s truth...*”. The respondent from institution I said: “*We encourage the integration of faith and learning looking at ethics, faith and discipline*”. This, however, is not considered as indoctrination by the above respondents for institutions A and I. However, the qualms some have against religious institutions were based on this feeling as expressed by the commission set up to study the establishment of a second university in Zimbabwe (Williams 1989: 58). The commission’s report states, in part, that

Church organisations have vested interest which may conflict with those of the state; that they promote sectarian beliefs which may undermine national unity;



and that they are likely to influence their protégés with an ideological outlook that is alien to the Zimbabwean culture. This is certain cause for conflict.

Some of the institutions, however, contended that they do not indoctrinate but intend to produce “*independent thinkers*” according to a respondent for institution I. Another one said that teaching of ethics may be some kind of indoctrination but “*we are teaching what is good, what is sound judgement. We are not fundamentalists and aggressive. We leave that to seminaries*”. The respondent for institution A argued that “*no body, be it an educator or scientist, exists without a world view even if it is atheist. So we have a world view, a Christian world view. That is what we communicate.... We do it deliberately and in a focussed manner*”. One referred to it not as indoctrination but “*Islamisation*”, showing the stand of Islam on various issues.

The core curriculum of most of these institutions, therefore endeavours to include what they perceive and believe to be their world view. This may have a connection with the attitude of these institutions towards the various social and learning ideologies in relation to their curriculum and mission. These are the subject of the next section.

#### 5.2.6.2 *Ideologies and the Curriculum*

In section 5.2.6.1 it has been alluded to that one of the fears why some governments were rather sceptical about authorising the operation of private, and particularly religious tertiary institution was the fear that they would teach different ideologies to the citizens with a potential of causing conflict (Williams 1989: 58). It was apparently, the same reason why many African governments took all the responsibility for the provision of tertiary education as indicated in section 1.1. This was despite the original proprietors of education in many parts of the region having been religious organisations. The same situation had prevailed in the countries under study as much

as in some other areas such as the United States of America. Ringenberg (1987: 77) said that “To be in a college in America before the civil war was to be in a Christian College”. The move towards a more liberal stance towards the establishment of tertiary private institutions may represent some tolerance of pluralism although the governments still have a varying but fairly high degree of control of the institutions.

In a similar vein, the history of education in many areas of Africa, including the countries under study, shows great involvement by religious organisations (Saayman 1991: 29). Literature indicates that one of the major goals of the religious organisation for establishing these institutions was to propagate their beliefs and then later, as a reaction against excessive secularism in public schooling, (Watson & McKenzie (1996: 179). At the extreme, Hill (1982: 10) wrote that “some Christian schools aim at fitting individuals into the small community of their particular denomination or sect without allowing them to question the values and beliefs pressed into them”. This could ostensibly be done by the approach the institutions take towards certain ideologies.

As regards secularism and other “isms” the following indicate that there has not been much experience with strong “isms” among the institutions studied. A respondent for institution A said *“Being a young university we are not necessarily immune to these ideologies but it depends on the commitment of the teaching personnel. If they are committed to the institutional mission they will have a positive influence so that there are no extremes”*. Another said that *“...we as Africans are religious people. So we can not divorce ourselves from religion even in public institutions.... We admit students from all backgrounds including different religious backgrounds and we observe all public holidays, but we expect them (the students) to live according to our institution’s ideals”*. These two respondents implied in their responses that they avoid extremes.

The respondent for institution D similarly said that all people are basically religious and answered as follows: *“These (the “isms”) cannot be avoided. They come in the discussions as we teach. We teach evolution, Islam, Communism and others but we, however, indicate what we believe as Christians”,* adding that *“...we are not aggressive. We leave that to the seminaries”*.

The following was another response by another respondent representing institution F: *“We inform all students coming to this institution that it is a Christian institution. We are, however, not naive as to what people may believe but we have not encountered them seriously. We have a fare amount of the quest for independence as one would expect in a university”*.

A respondent for institution H said that the responsibility is upon both the teachers and the students by stating that: *“...the university looks at these `isms` from the view point of learning...what they are. The teachers have to determine whether some `isms` are palatable to the Christian way of life and then guide them (the students) but the choice is theirs (the students)”*. The respondent, however, added that this emphasises the kind of teachers they would like to select to teach in that institution.

In a similar tone the following respondent representing institution I stated that *“...this is best handled in the classroom situation through general education courses such as Christian values....Students examine these issues critically not as `dos` and `don`ts` but as a basis to build their own world view. They should be independent thinkers not indoctrinated”*.

The respondent for institution J simply said that *“...we don`t have a policy. The people who are teaching deal with them without contradicting the standards of the Church. We don`t legislate”*; while another said that the university uses an interdisciplinary approach that balances all `isms`. This respondent acknowledged

them as contributors to knowledge adding like the rest:

We would endeavour to show them (the students) the other side of life and in terms of sharing knowledge, we are very open. We don't tell our lecturers what to teach. We want our students to know all the theories there are... but we also let our students know that it is noble to choose and determine their destiny.

The emphases in most of these responses are on teaching and individual choice based on sharing information from all ideologies but not indoctrination which, according to Hill (1982: 13) "...literally means putting doctrines into the learner". The emphasis on teaching is in keeping with what De Jong (1992: 22) identifies as one of the identities of Church-related colleges when he states that "A Church-related college's commitment to the integration of faith and learning is connected closely to an emphasis on teaching", seeking "to prepare students for principled leadership in all walks of life".

### **5.2.7 Aspects of the Mission of Private Religious Tertiary Institutions**

Traditional university mission has been the tripartite functions of teaching or instruction, research and community or public service (Strydom 1988: 3; Harvey 1994: 58; Wolpe 1995: 276). Wolpe (1995: 276), however, further inquires into the question to what proportions these functions are carried out by any specific institution. This should constitute part of the uniqueness of an institution's mission as Cabel (1993: 21) contends that missions, functions and roles describe the universities' purpose and their institutional characteristics which lead to the institutions' objectives that are achieved through the activities which they carry out.

All respondents acceded to the importance of a mission statement in the management of educational institutions (section 5.2.1.1). However, the responses indicated that there was disparity not only in the understanding of the term mission and its components, but also in its wording, development and articulation. Some gave the

mission as the objectives of the institution or its philosophy, others gave it in very brief sentence(s) and others were elaborate including the philosophy of the institution and the values the institution espouses. Some were able to articulate it without referring to any written document while others had to read it from paper. Some mission statements disclosed the institution's identity, delineated the institution's basic function as well as the recipients of the services provided, others did not do all that.

Table 5.1 below summarises the responses on the aspect of mission from the respondents.

Table 5.1 Summary of Responses about the Mission and Mission Components

Institution	Written Mission Statement	Statement of Philosophy	Values	Delineation of main function: T R & C	Identity	Delineation of Recipients of Services	Objectives	Comments
A	Available	Available	Enumerated	T R C	Specified		Enumerated	
B		Available	Enumerated				Enumerated	Mission is written in form of a Vision statement
C				T & R	Specified	Delineated	Enumerated	Mission given in outline form of objectives
D		Available	Enumerated	T			Enumerated	
E			Enumerated		Specified		Enumerated	Identity specified as a non-religious institution but business studies oriented
F	Available	Available	Enumerated		Specified	Delineated	Enumerated	

Institution	Written Mission Statement	Statement of Philosophy	Values	Delineation of main function: T R & C	Identity	Delineation of Recipients of Services	Objectives	Comments
G	Available	Available	Enumerated	T	Specified	Delineated	Enumerated	Mission was read not articulated, Philosophy given as faith statement, values given as commitments
H	Draft available	available	Enumerated		Specified		Enumerated	Mission statement was being reviewed
I	Available	Available	Enumerated	T & R	Specified	Delineated	Enumerated	Mission given in objective point form
J	Available	Available	Enumerated		Specified	Delineated	Enumerated	Mission statement very brief, only one sentence
K	Available	Available	Enumerated	T R C	Specified		Enumerated	Mission statement developed during the course of study
L	Available		Available				Enumerated	Values given in objectives not in mission statement

- T. Teaching
- R. Research
- C. Community Service

The blank spaces imply that the respondents did not give information on those items.

As may be deduced from Table 5.1, besides all respondents stating that they have a mission statement, some of the mission statements were written in the form of objectives. All institutions had objectives listed, most of them after the statement of mission except where they comprised mission statement itself. All respondents except for institution C outlined the values their institutions espoused mainly as part of the mission statement. These values (section 5.2.1.1), though generally different for each institution, represent what may be referred to as moral or ethical virtuous living and if pursued as written, the products of these institutions would be much appreciated by society. It remains to be seen whether the values are actualised.

As far as delineation of services are concerned between teaching, research and community service only a few respondents, four out the 12, specifically delineated the main function. Others either were silent on this issue or simply indicated the traditional tripartite role of university education. The idea of religious institutions is mainly teaching institutions (De Jong 1992: 22), featured in only two institutions D and G as the emphasis.

Another missing function of religious institutions is that of formation of the young people who attend the institutions as implied in the Catholic philosophy of education (section 4.2.7.1). The Seventh-day Adventist Church also includes the idea of formation of the students as part of its function in its education system regarding it as the balanced development of the students in every dimension of life (Rasi 1998: 1), in which case the church categorises formation into physical, social, moral or spiritual, and mental formation. However, only the respondent for institution K directly



mentioned formation as part of its functions as a religious institution by stating as one of its objectives as “...to play a fundamental role in the integral formation of the human person...”, (Institution K 1997: 1). Institution L referred to the formation of fundamental capabilities as one of its objectives, (Institution L Act 1992: 119), but this appeared to be different from the idea of individual personal formation as part of a mission of an institution.

As for identity many of the mission statements specified what the institution was by identifying the proprietor who was responsible for providing the services. These were in most cases the founding religious bodies. From the mission statements it was possible to tell to whom the institution was affiliated and was responsible for offering the services. However, fewer delineated the recipients of the services. Some of those who did were very broad. An example is “the English speaking Africans” by institution C which was rather broad.

Responses on the formulation of mission statement indicated different approaches particularly as far as involvement by stakeholders. Respondents for institutions A, F, G, H, and I, said that there was some involvement by staff in the process of formulating the mission statement with the final approval vested in the institutions governing boards/councils (section 5.2.2). However, institutions G and I said that this involvement was only in the reformulation of mission statements which had originally been formulated by the founding bodies. For the rest of the institutions the mission statements were developed by the founding bodies mainly during the inception of the idea of a tertiary institution in seeking national recognition. Some of which, such as institution E, already existed as non-degree granting institutions.

The latter is unlike Strydom’s (1989: 43, 44) proposal that many viewpoints from stakeholders should be obtained to promote reliability and implementation of the ensuing mission. In the opinion of the researcher, a mission statement handed down

from the founding body encourages a kind of patronage which deprives key stakeholders of the opportunity to contribute to the development of their institution. It is likely to lead to employees who only stay in the institution as long as they are receiving a salary and displaying unquestioning religious obedience instead of developing ownership of the institution that is desirable for institutions of that level despite religious devotion. This, in turn, enhances synergism and sense of mission (sections 2.7.2.1, 2.7.4, 2.8.). The same should be true of mission reformulation which all respondents agreed with saying that it is necessary to evaluate and review the mission statements periodically as long as the core mission is not lost (section 5.2.3).

A mission encapsulated in a mission statement would be of little value if it does not affect the lives of the stakeholders in practical life. As a tool of management (Campbell 1990: 23) the mission statement should affect all strategic planning (Harvey 1994: 51 and Detomasi 1995: 31) and be a standard by which the institutions policies, programs and performance are evaluated (McKelvie 1986: 152). It appears from the institutions studied, that more emphasis is placed on the inclusion of certain subjects in the curriculum in order to instil the mission into the lives of the students. Institutions A, B, D, H, I all indicated the inclusion of religious courses in the curriculum ranging from three semester credit hours to 18 quarter credit hours as a means of putting the mission in practice. The respondent for institution B, however, said that the subjects included are not doctrinal subjects but issues of social concern such as sex before marriage, rape, abortion, marriage, and moral living.

Other activities the institutions used to make the mission statement practical included chapel programmes which are compulsory in some institutions and voluntary in others. Respondents for institutions A, F and H also intimated care in the selection of members of the teaching staff while institution I said that the teachers are the key individuals who influence the life of the students. So they leave it to them to do so.

This stresses the importance of selection of the members of staff. Respondents for institutions F and I also indicated that they take care in the selection of students and that they emphasise the integration of faith and learning whereby the teacher is expected to approach every activity from the standpoint of their belief and faith. This requires that the teacher's world view is engulfed in the religious faith and has a relationship with involvement in the development of the mission of the institution as that is one way to enhance the teachers' devotion to the mission and religious faith. It also has to be done in such a way that the institution does not end up as only a seminary as this is one of the contentions against religious institutions, even those which are not seminaries.

It would be of interest, in the opinion of the researcher, to proprietors of religious tertiary institutions to study the impact of the inclusion of religious courses in the curriculum of religious tertiary institutions on the mission of the institution.

Otherwise the practice may simply constitute either copying what is done elsewhere without studying its usefulness hence turning out to be just another subject in the curriculum meant for the impartation of knowledge, or be tantamount to indoctrination.

Only respondents for two institutions, F and L, reported wide dissemination of the mission statement and it could be observed displayed on various notice boards in these institutions. Many of the others said that it was included in some of the institutions' documents in whatever form it was. The students' handbook was cited as the most common document that contains the mission statement giving an impression that management is specifically interested in the mission influencing the life of the students more than anything else.

In accordance with what Tierney (1988: 11) suggests, it is the opinion of the researcher that if the mission of the institution should guide all the activities in the

institution, it should be disseminated widely and clearly making it possible for all stakeholders to refer to it and eventually to be able to articulate it in any circumstance.

### **5.2.8 The Influence of Mission on Management of the Private Religious Tertiary Institutions**

A detailed presentation and discussion of research findings on the management of private religious tertiary institutions was presented in chapter four. This section, reflecting on the presentation and discussion in that chapter, discusses management in relation to the mission of the institutions.

Matejka *et al.* (1993: 34) contend that "...a great mission cannot occur without a vision", which they describe as a dream for the future. They then quote Father Theodore Hesburgh, the former president of Notre Dame University as having stated that "The very essence of leadership is (that) you have to have a vision. It is got to be a vision you articulate clearly and forcefully on every occasion. You can't blow an uncertain trumpet" (Matejka *et al.* 1993: 34).

This statement emphasises the important role of leadership (management) in having a vision (mission) and being able to articulate it to those being led. Strydom (1988: 3) argues: "it seems important to realise that leadership does not eliminate management". He then goes on to declare that "...universities need leaders who can turn their visions into reality by managing well". This is unlike what was happening historically, according to Strydom (1988: 5), when universities were not observed to be "planned" or "managed", "...when they proceeded calmly from year to year carried by their momentum and steered by traditional procedures and habits".

The above statement may not mean the actual dearth of planning, but an apparent smoothness of circumstances as compared to the current situation when universities

face so many challenges, some of which may be due to competition as new private universities get established. This may not be restricted to public universities alone but to the private ones as well and indeed as they are still new and needing management and must be strategically planned in order to operate viably.

According to the management structures presented in chapter 4, the chief executive of the institution, variously referred to as Vice Chancellor, Principal or Rector appears to have the greatest responsibility as far as ensuring that there is a mission for the institution, it is disseminated to all concerned and it is implemented. The founding organisations or denominations also have significant interest in trying to make sure that their mission is not lost so they take more precaution in the appointment of the chief executives of their institutions. They also endeavour to have sufficient representation on the governing boards of these institutions as discussed in sections 4.2.6.

Respondents to the interview appeared to avouch for this statement by responses such as the following: *“We try to recruit from the Church. Since these men (Administrators and staff) are important when it comes to the development of a philosophy or a mission,...the mission is consistent with the view of the owners of this institution and the overall world view of the...(founding church)”*.

The respondent for institution D, for example, stated that:

*“The episcopal conference is the governing council...including some representatives from the government...”. “The (the administrators) are all Episcopal appointees. The rest of the staff members are appointed by the appointments board making recommendations to the council for approval”*.

In apparent support of the importance of administration and faculty in maintaining

and implementing the mission of an institution the respondent for institution H said the following: *“First and foremost the administration must have a very sharp focus of where they want the institution to go because they are the driving force of the institution”*. The respondent added: *“The entire faculty and administration has the responsibility to live according to the mission of the university and to translate it in all the activities of this campus, at work, office or even at home”*.

The same notion was implied in the responses of other respondents although they did not make direct reference verbally. The respondents to the questionnaire were also in agreement that the consideration of the mission of the institution should play a very important and critical role in the selection of the top executives of an institution. They also indicated the same happens in practice with the exception of two respondents who felt that it was not considered as important at all. In both these cases the individuals indicated had been less than two years at these institutions.

The above-mentioned is in agreement with Bennis and Nanus' (1985: 89) definition of vision as an image for the future. They wrote that “The effective leader (and for this study the manager) must assemble for the organisation a vision of a desired future state. While this task should be shared and developed with other key members of the organisation, it remains the core responsibility and cannot be delegated” (Bennis & Nanus 1985: 141). Bennis and Nanus (1985: 154) continue and say that the leader's position must be clear and that “...we tend to trust leaders when we know where they stand in relation to the organisation...”. Additionally, Campbell and Yeung (1990: 21) suggested that “...continuity in leadership is one of the biggest contributors to creating a mission”.

The issue of institutional missions being handed down to them by the founding bodies may still be a factor as Assie-Lumumba (1996: 6) states it was at the inception of public university education when state authorities assigned to the institutions

missions to help achieve a vision of development for African societies. The balance between ensuring that the mission of the founding body is realised and tight control can be a delicate one. In the public universities, tight control by governments, according to Assie-Lumumba (1996: 7) is the major contributor to tensions which have almost become an intrinsic part of the public university. Generally, according to Sanyal *et al.* (1996; 43, 48), Sub-Saharan Africa is categorised among those regions whose institutional management system is under centralised planning and control. The same has the potential of bringing about the strained relations between private religious institutions and the governments and even between the institutions and their founding bodies.

Newman (1987: xiii), discussing autonomy and accountability, contends that what is needed is not simply autonomy but a relationship between the university and the state. To this the researcher would add a relationship between the private university and the founding body, that is constructive to both parties and built up by careful attention on the part of all the parties, within the boundaries of appropriate missions. Additionally, Hines (1988: 39) argues that complete accountability where the campus becomes a state agency or autonomy which completely ignores the legitimate interest of the public are unattainable and may be undesirable.

The model proposed in section 4.3 endeavours to take care of this kind of situation by ensuring mutual respect as well as recognition of each others' sphere of operation and responsibilities. In the opinion of the researcher, this better be done when the institutions are still in their infancy stage than waiting until it may be late for any entrenched systems to be changed. The result shall be a strengthened partnership unlike the one dominated by the government which is weak, according to Siyakwazi (1995: 323) who contends that when the government dominates the resulting partnership is a weak one.

### 5.3 SUMMARY

In this chapter, data collected on the subject of mission and mission statement of the private religious tertiary institutions studied was presented and discussed. The chapter began by identifying topics and categories which emerged from the segments of data obtained from the study by interviews, document analysis, observation and the questionnaire. The categories are presented and discussed under the topics: mission and mission statements, mission statement development, mission in practical life of an institution, dissemination of mission, curriculum and institutional mission and management and institutional mission. Additional emerging categories were included as sub-topics and presented as well.

The term mission and mission statement were variously understood as depicted in the different responses as well as from the documents. Some were given in the form of objectives, others were quite brief and not encompassing what is generally expected to be included in a mission statement. Despite these differences, all respondents emphasised the need for a mission statement in the management of the institutions. They are also a requirement by government accrediting bodies. None of the statements could be classified as messianic or anthology type missions. They represented a mixture of the other types of mission statements as seen in section 5.2.1.2.

Similar to the concept of mission, respondents had various opinions about the procedures for developing a mission statement. Some institutions' mission statement were passed on to them by the foundation body, others had been developed at the inception of the institution by a group of individuals, and others developed through stages which involved teachers, administrators and other stakeholders.

In a similar vein the reformulation of mission statement was approached differently



by the various institutions. Some had not had their mission reviewed since their inception, others said their missions were still being refined and some had revised their missions a few times. Most of the respondents felt that the basic mission does not change but its formulation or wording since they believed that their mission should remain as it was based on Holy Scriptures. A few respondents implied that they could restudy their institution's mission depending on the prevailing and changing circumstances.

The mission of an institution would be of no value if it does not influence the practical life of an institution. Moreover, the institutions studied claimed to desire to provide unique education. It is, therefore, imperative to study the influence of the mission on practical life. This was, in some instances, given in terms of religiously oriented courses included in the curriculum. However, the kind of institutional personnel, particularly the teachers, was stressed as most important in shaping the mission of an institution. Most institutions avowed to recruiting faculty and teachers of the same persuasion as espoused by the institution in order to ensure that the institution's basic mission is maintained.

Some of the measures to ensure that the mission was translated into the practical life of the institutions, such as the teaching of religious courses was not without criticism. Some of the criticisms were that the institutions were being operated as seminaries not as universities and they came from within the institutions as well as from outside. This portrayed the various understandings of the role of universities.

Besides mission in practical life, the mission has to be disseminated to all the stakeholders in an institutions. The most common method used in the institutions studied was through the institutions' official documents such as the prospectus, student bulletins and staff handbooks. There was no homogeneity in the method of dissemination although there appeared to be more use of the student handbook. This

was probably to make sure the students' life is governed by the mission more than anything else.

In addition to dissemination in the official documents, the core curriculum of many institutions, already seen above, consisted of compulsory religious courses of varying credit hours. This was not considered indoctrination but shaping the lives of the students according to the institution mission and values.

It was further observed that additional attempts to ensure the mission of the institutions is safeguarded, the founding bodies of these institutions take extra care in the selection of the management teams both as governing councils as well as the institutional administrations. It is individuals sympathetic or of similar persuasions to the founding bodies who appointed to those positions except where the government requires its representation such as in Zimbabwe. However, even in such cases where it is a government requirement, there is consultation with the founding bodies before representatives are selected. This is required only at governing council levels.

From the research findings conclusions were made regarding the management and mission of private religious tertiary institutions. There were areas which were identified which may require further research as well. Chapter six, therefore, presents a summary of the findings, conclusions and recommendations for further research.

## **CHAPTER 6      SUMMARY, CONCLUSIONS AND RECOMMENDATIONS**

### **6.1    INTRODUCTION**

Chapters four and five presented data as collected by observations, interviews, document analysis and the questionnaire during the study on management and mission of private religious tertiary institutions. The data represented a diversity of understandings of the term mission but stressed the importance of institutional mission. This was done by synthesising the data into categories and possible hypotheses.

The process of analysing qualitative data, as mentioned in section 3.2.3, is a rigorous and iterative one which includes moving backwards and forwards in order to discover and organise meaning from the voluminous thick data collected during the research. Section 3.3.8 also referred to synthesising the data along with categorising and discovering themes as part of the process of analysis of qualitative data. This involves deciphering the results for meaning and discovering themes which may lead to hypotheses. In this chapter the researcher summarises the findings from the research, presents the conclusions from the findings and suggests areas that may need further research and makes recommendations to the proprietors of the institutions which may also be of value to the policy makers.

The main religious organisations that were found to be involved in establishing tertiary educational institutions in the eastern and southern region of Africa were the Catholics, the Anglicans, the Seventh-day Adventists, the Muslims and the Methodists. Each of these religious organisations has a basic concept of education (section 4.2.7). These helped in understanding mission and the management of tertiary religious educational institutions, most of which were affiliated to one of the

above religious organisations.

## 6.2 SUMMARY

As Maphosa (1996: 1) and Saayman (1991: 29) were noted in section 1.1 to have stated, religious organisations were involved in the introduction of formal education in the countries under study. This historical background was also noted from the responses in the study as providing a justification for the development of private religious tertiary institutions in these countries. In a similar vein, Maphosa (1996: 1) stated that the development was a natural consequence of the trend started by the earlier missionaries. Referring to the commission given by Jesus to “spread the Gospel” by some of the institutions affiliated to the Christian faith they appear to be justifying the origin of religious education to as far as the time the commission was given.

As the religious organisations continued to evangelise the nations, they designed strategies to penetrate the cultures with the Gospel as stated by a respondent for institution E. This was began by the introduction of schools of lower levels. However, as the churches grew, the need arose to train African nationals and missionary personnel as stated by the same respondent, and it apparently became necessary to upgrade the institutions to tertiary levels. This could, therefore, be one of the reasons for the development of tertiary institutions at the time they were developed. Most of them began by offering religious programmes. A respondent for institution K reported that the first degrees they offered were only canonical degrees in theology.

Whereas this might have been a justifiable reason for the development of religious private tertiary education, other responses indicated that the reason may have been the great demand for education in the countries studied as stated by a Ministry of Education official in Uganda (section 4.2.2.3 and 4.2.6.1). These two reasons,

however, are not mutually exclusive. In the opinion of the researcher the two reasons buttress each other. As the religious bodies continued to grow and require more qualified personnel within themselves, the demand acknowledged by the Ministry of Education official, also became defensible increasing the justification for the introduction of private religious education. Some religious bodies desired to and applied for permission to establish recognised tertiary institutions earlier but the policies then were such that the governments alone had the monopoly over the operation of such tertiary degree granting institutions as seen in section 1.1.

Institution F is one of those that applied for almost twenty years before it was granted the charter by the government.

With exception of the Moslem related institution and a few Christian ones such as institution H which, from the start developed as tertiary institutions, the development of religious tertiary institutions has passed through a series of stages starting from either lowest levels, training institutions or seminaries. Institution A developed from a teacher training school as well as a secondary school to a university. Institution F of similar religious affiliation also developed from a training school of teachers and pastors as well as a secondary school to the current chartered university, table 4.1. This further demonstrates that development could have been a natural maturation of what had begun as small missionary schools. These stages, in the opinion of the researcher, might have served as stages of preparation required for institutions for the greater responsibilities of operating tertiary level institutions granting recognised degrees.

Besides institution G which was operating as a seminary for the training of ministers, the rest of the institutions said they were not seminaries. A respondent for institution D emphatically stated that indoctrination was left to the seminaries. Thus, he endeavoured to make a clear difference between institution D as a university and other institutions which are seminaries responsible for the training of clergy (section

5.2.6.1). The same notion was expressed by others and some of them, which had been registered as seminaries before, had to change their registration upon aspiring to become universities.

Despite the apparent ease with which governments registered seminaries in respect of religious freedom, the institutions which were aspiring to become universities were not quick to register themselves as such. There is therefore, in the minds of the proprietors, a difference between seminaries and universities, the accusations that they operate like seminaries notwithstanding (section 5.2.4).

By virtue of being private, the institutions studied declare that they do not belong to and have not been established by the government. Additionally, the definition of private educational institutions as those which do not receive financial support in full or part from the government as seen in section 2.4 tends to relate their privacy to financial support. The issue of ownership was related to financial support by a number of respondents, such as respondent from institution A who said that “*we are owned by... and receive some funding*” (section 4.2.2.1). Even the one who was rather sceptical about church ownership based it on financial support. This can be as seen in section 4.2.2.1 in a response given by a respondent for institution J that there was little maintenance by the founding church leaving the institution struggling financially. It is only the multi-religious and the non-denominational institutions I and G which indicated that no single church claims ownership over them. Institution E was non-religious so would not be expected to be owned by a religious body.

Despite this relationship between financial support and the issue of ownership, there were more respondents who were happy to be identified with their founding religious organisations with or without financial support. Section 4.2.2.1 reports many such responses, such as “*it (the institution) is owned and run by the church*” by a respondent for institution F. Some indicated ownership by religious related

organisations such as the Bishops of the Association of Member Episcopal Conference of Eastern Africa. There appeared to be some dignity associated with belonging to or ownership by a religious body. Even those respondents who reported minimal financial support were not inimical about their belonging to founding religious bodies. One respondent reported having received other non monetary forms of support which could, at times, translate into more than the institution would receive in terms of financial support.

The non-inimical disposition of the respondents interviewed may be an illustration of the sense of ownership the respondents have for the institutions. It is clear that one does not only join an institution by employment alone but by a deep conviction and commitment on the part of the respondents. The issue of ownership, according to the respondents who were mainly administrators, did not seem to interfere with autonomy which institutions of that level, especially universities, usually would like to claim. The sense of commitment in turn comes as a result of a sense of mission which is not only important to inculcate among the subordinate employees as seen in section 2.7.4 but also among the top administration. Campbell and Yeung (1990: 22) was cited in section 2.7.4 as having suggested that sense of mission among the top management is crucial particularly in disseminating values. The researcher would like to expand this dissemination to include the entire management of the institution as requiring the sense of mission. Sense of mission also presupposes a thorough understanding of the mission of the institution and the founding religious body as well as its basic concept of education. It is this sense of mission which also determines the kind of relationships the institutions enjoyed within themselves and with other institutions, both private and public as well as with the government.

The kind of relationships religious institutions foster should be expected to depend on, and be influenced by their basic concepts and emanating mission. This should be particularly so as regards the relationships within the institutions themselves which

determine the standards of behaviour of their personnel. The influence of basic concepts and mission on relationships, however, should also be expected to influence the institutions' relationships with other institutions either private or public and with the government. The findings on this subject which included the statements recorded in sections 4.2.3.1, 4.2.3.2, 4.2.3.3, 4.2.3.3 and 4.2.3.5 indicate the kind of relationships which exist among and between religious private institutions.

Statements reported in section 4.2.2.2 such as "*...the curriculum ... puts God at the centre of everything that we do...*" and "*...to see to the islamisation of the community...*" given by institutions A and C when referring to their mission in practice, indicates an intentionality on the part of the institutional management to influence whatever takes place in those institutions by their basic philosophy of life. Another institution referred to the relationship between the Gospel commission and the mission of the university which was telling "*...people about God in various ways... so that they can see the love of God...*" (section 4.2.2.2). Since religion influences, the intention of this institution is to influence personnel within the institution through presenting God to them.

Besides these, other statements by institutions A and F included the emphasis placed on who is recruited to teach in some institutions since these people "*...are very influential when it comes to the development of a philosophy or mission...*", encouraging cooperation rather than competition, the establishment of an orientation week "*...to assess the spiritual maturity of the students*", and the acknowledgement of the inclusion of compulsory religious courses in the curriculum, (section 4.2.4) are further evidences of the desire to influence the lives of the students in line with the missions of the institutions. These statements were given in describing how the mission of the institutions is translated in the practical lives of the personnel in the institutions.



A respondent for institution D, however, despite describing the inclusion of a course in ethics as part of all courses, acknowledged that there is no “...*guarantee that the student's lives shall be transformed*” (section 5.2.4). This acknowledgement, in the researcher's opinion is not acceptance of failure in what the institutions are trying to do but a realisation that influencing peoples' behaviour can not be taken for granted and that different individuals may be influenced differently by similar means or take longer to be influenced. It is a matter of changing a culture which is not easy to change. It may also be a partial explanation why some students may comment on the family relationship they experience at a religious tertiary institution while in another institution endeavouring to foster the same spirit, cases of disagreement emerge leading at times to problem resolution in the civic courts.

Another possible cause of such disputes may be only having the desire on paper but not implementing it by example by either the management or the staff of the institutions. Stressing the need to be careful in selecting staff attempts to deal with this situation. The institutions which indicated that they are careful in selecting their staff also said that they believe that these people are very important in establishing the mission of the institution. It, however, has to begin with management setting the example.

The practice of including religious or religiously oriented courses in the curriculum of the institutions is yet another practice which can yield good results as far as the realisation of mission statement is concerned. It, however, is an area that may require further research to investigate its effectiveness in achieving the intended results. Otherwise, such religious courses may be regarded in the same light as other courses in the curriculum with little effect in strengthening the mission of the institutions. The researcher has served on evaluation committees where students have raised questions as to the relevancy of such courses to their future careers. As hinted in sections 5.2.4, this might be one of the reasons why some contend that these

universities are operated like seminaries.

As indicated in section 4.2.3.5, since most of the institutions studied were still relatively new just as the phenomenon of private religious education itself, there were yet no formal relationships between these institutions. There was yet little sharing of information between different private institutions. On the other hand, there was no suspicion of each other. Instead there was more sympathetic understanding among them and efforts were being made in Uganda to establish some formal forum to share ideas as reported by respondents A and E (section 4.2.3.5). These attempts were not intended to be limited to religious institutions only but also to other private institutions. In Kenya and Zimbabwe there was as yet no attempt to develop with such a forum but the institutions participated in each others' special occasions such as graduations. The idea of admitting students from only other chartered institutions as stated by a respondent for institution H (section 4.2.3.5) may be regarded as a respect for the recognition of the other institutions which have such recognition usually through the charter or other accreditation where it exists.

It was intimated by a Ministry of Education official in Zimbabwe that the preference of the government would be to have the private institutions affiliated to the public universities but the institutions did not desire to be affiliated to government universities. This may be explained, on the part of the government, as a continuation of the original desire to have entire control of higher education in the countries under study as indicated in section 1.1. On the part of the religious private institutions, possible explanations may include the desire for autonomy to fulfil their missions as well as the suspicion that such control may limit their expansion and the provision of the needed personnel requirements for their founding religious bodies.

The relationship between the private institutions and the public institutions are not exactly like those between different private ones. The public institutions are looked at

by some private institutions as a source of lecturers since many of them are still in the process of recruitment and building up staff. Another aspect of the relationship is that the public institutions, in addition to providing part-time lectureship, also provide opportunities for staff development for the private institutions in a more cost effective way as intimated by a respondent for institution E (section 4.2.3.4). They also provide other required resources which have not yet been developed by the private institutions such as library and science laboratory resources. It is likely that this kind of relationship will continue for the foreseeable future for many of the private institutions. It is the opinion of the researcher that this is a good relationship which should be encouraged and maintained because of the mutual benefits that could be gained from such collaboration. It may also lead to cost saving as some of the resources such as recreational resources may not have to be duplicated if the institutions are within the same locality.

Despite the benefits of such relationships some respondents expressed feelings of apprehension due to the apparent competitiveness emerging among the public institutions which are establishing the same kind of programmes as the private institutions, as stated by a respondent for institution B (section 4.2.3.4). The researcher did not try to discover whether such moves were a result of rivalry or had been part of the long term plans of the institutions in question. It nevertheless created some discomfort among some proprietors of private institutions who were struggling to develop and could not cope with having to compete for students with already established and fairly funded public institutions at such a time.

The relationship between private and public institutions are therefore a combination of support shown on the part of the public institutions and feelings of apprehension shown by some private institutions. In the case of private institutions the benefits of collaboration would be of much value to the developing phenomenon of private education, yet on the other hand some degree of competition to excel in services,

including academic services, may, according to the researcher, strengthen the academic programme of all institutions.

As stated in section 4.2.3.3, relationships between private institutions and the government are different from those of public institutions and the sponsoring governments. The latter are more of patronage type although the public institutions do not desire that kind of relationship except financial support. This occasionally results in conflict and tension.

As far as the private institutions are concerned, they have to fulfil the requirements of the governments specifically outlined in the procedures of registration and recognition by the various bodies responsible for such registration, the Commission for Higher Education in Kenya, the National Council for Higher Education in Zimbabwe and the proposed National Council for Higher Education in Uganda (sections 2.5.2, 2.6.1, 2.6.2, 2.6.3, 3.3.6 & 4.2.5.2). Having fulfilled the requirements, so far there has been minimal interference in the operations of private institutions by the governments.

The responses did not indicate any adversarial relationships so far. A possible explanation for such “cordial” relationships could be the hope that such a development would assist to provide the needed education the governments are unable to provide to those who qualify for it. Another possible explanation could be that the institutions are still quite subservient to the government rather than being assertive. In public statements made by the government personnel, private religious institutions have also been hailed for restoring morals to the public (appendix E). This could be a strength to be exploited for the good of the countries. According to Teese (1989: 112), the academic and social benefits of private schools frequently depend on the administrative autonomy of the individual establishment in addition to its market adaptation and the power of the head to implement the school policy. This statement

seems to support the desire for autonomy of private institutions which know their mission in accordance to the needs of the society.

An important consideration is whether the acceptance of funding from the government by these institution in form of grants may not jeopardise this desired autonomy.

As regards the issue of funding, the kind of funding appears to be an important distinction between public and private institutions by the definition of private institutions (section 2.4). Secondly, literature referred to private institutions as alternative sources of funding for education (section 4.2.4). Responses to the issue of funding, therefore, impinge on the very essence of private educational institutions.

The commonest source of funding for private institutions was cited as the fees paid by the students. In all three countries where tertiary education has traditionally been funded by government, the paying of fees by students is likely to be a contentious issue. Additionally, operation based on students' fees is inadequate, rather erratic and hard to depend on as the sole source of funding in countries which are experiencing economic hardships.

Other sources of funding as indicated in section 4.2.4.1 included sponsorship by the founding religious bodies in terms of finances as well as other non-financial donations such as land and vehicles. Financial support by the founding bodies was, however, cited as a small source of funding accounting for, "*...less than 5% of the requirement*" for institution A. There was no evidence of a higher percentage except for institution L which indicated that for a few years prior to the study the institution could afford to provide bursaries to all students enrolled as it still had sufficient funds from the founding body to do so section 4.2.7.1. The same institution L was reported to have set up an endowment fund with funds received through special gifts in

anticipation of hard times that might come in the future. The researcher did not investigate whether other institutions had set up such endowments. The researcher, however, is of the opinion that establishing endowments should be encouraged by management of all institutions. Some may find it difficult when operating on daily survival, yet on the other hand, it is essential for the long term survival of the private institutions.

As mentioned in section 4.2.4.1, private institutions face the dilemma of having to fulfil their obligations with limited financial resources and yet offer quality education without overcharging the students in form of fees. Caught in such a situation many of the institutions have tended to look to the government for financial support.

One of the easiest source of funding that private institutions turn to when they experience problems and one which is often justifiable is the government. It is justifiable because the governments have the responsibility of providing education to all the citizens of their countries. Furthermore, private students come from families which pay taxes to governments as all other citizens. As indicated in section 4.2.4.2, Kenya and Zimbabwe were already providing some funding in form of student grants and/or loans to students studying in private institutions based on the justification above that the students in private institutions are also citizens of those countries who should be entitled to similar conditions and rights as those of their counterpart in public institutions. Furthermore, the government in Zimbabwe, for example, sponsors students outside the country, sometimes to private institutions in those other countries. It would appear incongruous to do so and not do likewise for those studying in private institutions within the country which the government itself has approved. This appeared to cause no problems as long as the government remained a sponsor just like a parent would be. Besides one respondent for institution K who avowed no interest in government funding (section 4.2.4.2), many of the others said they would not be opposed to government grants, some would even desire more than

students' grants, as long as those funds came with no strings attached. This in turn appears to depend on the definition of "strings attached" as understood by both the government and the private institutions themselves. The Minister of Higher Education in Zimbabwe, for example, said that he is accountable to the public and the parliament for the funds spent in his ministry including grants for students and educational institutions (section 4.2.6.1). Consequently, he may be expected occasionally to check on how such funds are expended. This may be interpreted as interference in the operation of the private institutions which desire to remain independent despite such support. It is the opinion of the researcher that in places where such grants are available clear guidelines should be outlined as to the responsibilities of each party involved to avoid any vagueness between either party. The same should apply to any other source of funding particularly those with a potential of becoming regular sources of funding or being used to gain some advantages. These guidelines should be in line with the missions of the various institutions and private institutions and should avoid what Gross (1987: 27) referred to as "funding chase" (section 4.2.4). This concurs with what Cooper and Gargan (1996: 159) implied when they reported concerning research findings in the United States of America that too much dependence on state funding may cause private institutions to lose autonomy and their unique identity. This, in the opinion of the researcher, is not restricted only to the United States of America but may occur in the region of study as well.

In addition, dealing with public funds of any nature requires a high degree of accountability as indicated in section 4.2.4.3. This is especially true of private religious institutions which require funding from the recipients of the services they provide and which funding is usually more than what may be required by government institutions. Any questions that might arise in connection with handling of funds in such institutions are likely to raise a lot of interest and if accountability is lacking, the institutions as well as the founding religious bodies may lose credibility.

### 6.3 CONCLUSIONS AND RECOMMENDATIONS FROM THE STUDY

The present study sought to understand the role of institutional management in the formulation of a mission statement, its implementation in the life of institutions, the influence of religious missions on those of the institutions, and the uniqueness of private religious educational missions and the *raison d'etre* for establishment. From the foregoing observations and discussions in chapter four and five, the following conclusions were arrived at for both practice and policy formulation.

Private institutions and religious ones, in particular are aiming to meet a felt need in the provision of education in the countries studied. The demand for higher education is still great. The public higher educational institutions, which have hitherto provided such education can no longer satisfy the need and yet the state governments do not appear to have the funds to expand as fast as the demand requires. On the other hand, religious institutions have been involved in the provision of education at the lower levels and appear to be ready to venture into the provision of higher education. In countries like the United States of America colleges of higher education were mainly started by religious organisations as implied in the statement by Ringenberg (1987: 77) that “To be a college in America before the Civil War was to be a Christian College” (section 5.2.6.2). Likewise much of schooling in the region was began by missionaries. Some have indeed desired to establish tertiary education institutions before but were only hampered by the prevailing government policies (section 1.1).

Provision of education by private enterprises is therefore a welcome development in the region studied both to the aspirants for higher education as well as for the governments which can no longer meet the need.

The smallness in size of the private religious institutions as indicated in section 4.2.2.3 might be due to the inadequacy of facilities and resources for those which



desired to expand, or due to intentional desire to remain small as some believe that religious institutions should be small and residential in order to be able to influence each student enrolled in a religious sense. The small size notwithstanding, the institutions should not be regarded as being inferior to the larger ones. Instead, they should be given the encouragement, support and guidance to develop into institutions that provide quality education to the aspirants. Such guidance would begin with developing mission statement for the institutions.

Despite the disparity in the understanding of a mission statement and the resulting differences in the mission statements provided all respondents avowed to the importance of a mission in the operation of an institution. It provides the direction and reason for existence. Without a mission statement the institutions may be swayed by any possible winds of change. The policy makers need to be tolerant to various points of view, referred to as world views, which the different proprietors of higher education espouse. This, however, does not mean neglecting the governments' responsibilities of ensuring that quality education is provided within their borders. Hence the need for support as well as guidance. The governments constitute managers of the affairs of the country and among their management tasks is controlling which involves setting required standards, measuring those standards, evaluating them, and taking corrective action where necessary (sections 2.3.3, 2.3.4, 2.7.4). As a result a degree of control is necessary on the part of the government on all educational institutions including private religious institutions. The institutions should expect this control along with some degree of autonomy balanced with accountability.

It is, therefore, important that the requirements for establishment and recognition or accreditation of private institutions be made clear to all proprietors of educational institutions and be adhered to in all circumstances. The institutions on the other hand should have clear mission statements which define what they exist to do. The mission

statements should, at the minimum, designate the institutions' identities, the services provided, the intended recipients of the services and standards of behaviour expected.

In cases where the governments provide some funding to private institutions the conditions for receiving such funds should be streamlined as well. This would require clarifying whether the government will provide grants to the institution on a regular basis or not; or whether only students grants shall be provided. Attempts have been made to do so in Zimbabwe where the government provides grants to the students. However, there is still the perception that these grants are given with more strings attached than would be expected, yet on the other hand the minister needs to account for funds allocated to the ministry of education. The concept that the grants for students' funds be considered in the same way as parents paying of fees should be encouraged. Parents do have a right to know how their money is utilised but do not control what takes place in the institutions. The students go to those institutions by choice so they can only check whether the school provides that which it purports to provide.

On the other hand, it has been stated that the chase for funding can cause private institutions to lose their sense of mission (sections 4.2.4.2 and 6.2). Proprietors of private institutions, therefore, need to plan carefully, particularly for their funding so that they do not lose the core mission for their existence as a result of chasing funds. Such funds received as donations from both the governments as well as from other sources should be put into endowments for the future support of the institutions so as to reduce the chase for funding. Moreover some religious institutions contain within their basic concept for education, statements that education should be holistic. This is interpreted to include all spheres of learning, the mental, spiritual, physical, moral, and social and the practical implementation thereof (section 4.2.7.3). The latter does not appear to be translated into reality as much as should be expected yet it would be another way of generating internal funds while providing education. There ought to

be more intentionality in putting this into reality in the life of institutions. They would also be, by so doing, providing a unique service to their adherents instead of providing what is already being made available elsewhere and scrambling for the same funds.

In the area of moral education, lists of values were given by each institution either in the mission statement or in the statements of objectives as the desired behavioural standards expected. These values, as summarised in section 5.2.1.1, indicate the institutions' commitment to their founding religious bodies whose creed include these values. This is one way the founding religious bodies' missions are expected to influence their educational institutions' missions. The institutions studied generally endeavour to incorporate these values in the practical life of their institutions through the inclusion of courses in the curriculum and in other programmes. The founding bodies also strive to achieve this by making sure the management of these institutions at all levels includes the bodies' interests. They endeavour that the selection of institutional chief executives as well as teachers in most cases is done carefully to include those who will present their mission to the adherents. Private religious tertiary institutions, therefore, have a unique mission to contribute to the education systems.

Some of the religious bodies have their own accrediting bodies which have a degree of international recognition, such as the Accrediting Association of Seventh-day Adventist Schools, Colleges and Universities (AAA) for the Seventh-day Adventist Church and the Accrediting Council of Theological Education in Africa (ACTEA), a regional interdenominational accrediting body for religious studies only. These bodies are agencies used by the religious bodies to ensure that the institutions they operate meet the required religious and academic educational standards. They also take into account the national accrediting standards. It is, therefore recommended that these bodies be recognised by the governments because their efforts are complementary to the efforts of the governments. The management model proposed by the researcher in

figure 4.1 section 4.3 seeks to accomplish this mutual respect.

It was noted that the level of participation in the development of mission statements was not what is desired. Some of the institutions had their mission statements developed and given to them by the founding religious bodies. This is contrary to what literature suggests. In order for mission statements to be accepted and for a sense of mission to be enhanced, there ought to be the involvement of all stakeholders (sections 2.7.2.1, 2.7.4, 2.8 & 5.2.7). The institutions ought to introduce a system of mission development that includes, by representation, all stakeholders and establish a procedure that includes the steps as suggested by Ishoy and Swan (1992: 11-15) (section 2.7.2.1). It, however, remains the responsibility of management to ensure that this process takes place and that the institution has a mission statement.

In order to be able to perform the above functions efficiently, training in educational management would be expedient. Training of chief executives of religious tertiary institutions in educational management either by pre-service arrangements or in-service courses organised by proprietors of religious tertiary institutions is advisable to enable the managers at different levels to be abreast of contemporary educational management issues. In the opinion of the researcher, such positions should be occupied by individuals who have had basic educational training with a component of educational management.

### **6.3.1 Summary of the Recommendations**

The following is a summary of the general recommendations that emerge from the study:

- The efforts of private religious tertiary institutions are complementary to those of the governments and should be supported and guided within the confines of

their mission statements and the expectations of the general goals for education (sections 4.2.3.4 & 6.3).

- All institutions should have a succinct and clear mission statement to guide all their operations and it should be widely disseminated to all stakeholders (sections 5.2.7, 5.3 & 6.3).
- When governments exercise control over the private institutions despite the institutions having their own management structures, they are exercising their managerial responsibilities of controlling the educational quality of their citizens. Therefore, this should not be regarded as interference or with contempt (section 6.3).
- When governments are exercising their responsibilities, there ought to be a balance between autonomy and accountability on the parts of both the government and the private institutions (section 4.2.4.3).
- Clear requirements and procedures for recognition and accreditation should be developed and made known to all potential proprietors of private institutions in areas where this has not been done yet.
- Likewise, clear guidelines and conditions for funding, if any, from the governments, should be provided to all stakeholders including the recipients of the services (section 6.3).
- Private religious institutions, on the other hand should resist the temptation of a “funding chase” by doing strategic planning and considering what it takes to operate institutions of that level before they embark on a venture of that nature.
- Institutions should be intentional in making their education unique by providing courses that are more practical which would also help them by providing financial income and/or savings as well as making a special contribution to the education system.
- Institutions should establish endowments so that they have a buffer against bankruptcy and to protect them from over-dependence on external funding. One possible source of funds to set up such endowments is from well-

- organised, purposeful follow-up contributions from alumni (section 6.3).
- Governments should recognise that other church accrediting and management bodies are complimentary to the government efforts and should be recognised in the hierarchy of institutional management. On the other hand, religious bodies should not be secretive about such bodies but should make the government aware of them for mutual benefit (section 4.3 & 5.2.8).
  - Proprietors of private religious institutions and their management should use participatory management and involve the stakeholders in the determination and reformulation of their mission statements and the subsequent goals and objectives to enhance sense of mission and ownership (section 4.3 & 5.2.7).
  - Proprietors of religious tertiary institutions should arrange for the chief executives of their institutions to be kept abreast of developments in educational management (section 6.3).

### **6.3.2 Recommendations for Further Research**

This study attempted to provide some understanding of the emergence of private religious tertiary institutions in Eastern and Southern Africa. The study could not provide all the answers to questions practitioners and policy makers may have on the subject. It might also have raised some questions that will need further research. In concluding this study, in the opinion of the researcher, the following need to be researched to provide further insights and understanding on the subject of private education in general and private religious institutions in particular:

- The longevity of the current demand for education. In strategic long-term planning it is expedient to have information on how the demand for higher education is going to be like in the long run so as to conserve limited resources for other kinds of development. It would also be prudent to consider other kinds of training which such developing countries require in order to sustain

their economies.

- The effect of including religious subjects in the curriculum. It may be of interest to the religious proprietors and managers to find out the actual impact of these subjects in the life of students in comparison with studies that may have been done elsewhere.
- Perceptions on the degree of autonomy and accountability among different levels of management of private religious tertiary institutions.
- The role of women in the management of private religious tertiary institutions. Only one chief executive for institution I was female. Otherwise, all the other respondents in the current study occupying managerial positions were males. This may be due to the historical background of most religious institutions which have emphasised masculine management, some of them having evolved from seminaries. In education, however, both genders can perform the function of management. How this would be perceived might be a subject of interesting research.
- The perception of different management levels regarding the issue of student involvement in participatory management.

#### **6.4 GENERAL CONCLUSION**

Educational management like all management and other sciences is an evolving area of study. Changes keep on occurring in the approaches used in educational management with much emphasis being placed on strategic planning for all educational endeavours. Strategic planning begins with visioning and development of a mission statement which defines the *raison d'être* of any organisation.

It is during such time that the countries of East and Southern Africa have begun experiencing the unprecedented development of private tertiary institutions. Having previously not allowed private tertiary institutions, the development is a challenge to

the countries which requires careful planning particularly as they all seem to be experiencing economic hardships. Nevertheless, the development of private tertiary institutions appears to be providing a respite to the governments which are faced with a great demand for such education but being unable to deliver it to all qualifying candidates. Most of the private tertiary institutions have been established by religious organisations. The governments, however, are yet faced with requests and/or demands for funding for the private institutions even from those established by churches which are, in turn, finding it difficult to operate the institutions they have initiated due to financial difficulties. The questions that arise from this state of affairs were the subject of this study and the conclusions are that there ought to be prudent strategic planning by the proprietors of the private institutions before they establish the institutions. On the other hand, the governments should exercise their managerial responsibilities which include controlling the quality of education provided to their citizens beginning with providing clear guidelines for establishment of educational institutions and requiring adherence to these requirements by all proprietors. The idea that schools are not supermarket of values where people pick and choose as they like (Bottery 1995: 51) would apply to the education system as well. Appreciation the individuality of judgement and subjectivity of values, according to Bottery (1995: 51), "...does not imply relativity but guardedness against strident espousal of ethical positions, tolerance of others, and an awareness of personal fallibility". This, in the researcher's opinion can be achieved through the proposed model of management of private tertiary institutions in section 4.3 which will take into account the input of the various management and accrediting bodies of the proprietors of the institutions in a participatory management approach.

It is also recommended that institutional managers and all those involved in the management of private tertiary institutions be exposed to regular management training programs in addition to their pre-service training so as to keep them abreast of contemporary educational management issues and approaches.



## REFERENCES

- Anderson, G. L. 1994. The Cultural Politics of Qualitative Research in Education: Confirming and Contesting the Canon. *Educational Theory*. 44 (2, Spring): 225-237.
- Anderson, G. L., Kathoy, N. H. & Nihlen, A. S. 1994. *Studying Your Own School: An Educator's Guide to Qualitative Practitioner Research*. Thousand Oaks, California.: Corwin Press.
- Andrews, S. 1970. *Methodism and Society*. London: Longman Group Ltd.
- Arth, A. A., Johnson, J. H., Lounsbury, J. H., Poepfer, C. F. Jr. & Melton, G. E. 1987. *Developing a Mission Statement for the Middle Level School*. Reston, Virginia: National Association of Secondary School Principals.
- Asquith, J. (Chairman). 1945. *Report of the Commission on Higher Education in the Colonies*. Presented by the Secretary of State for the Colonies to the Parliament by His Majesty. Command Papers 1945-46. London, Great Britain.
- Assie-Lumumba, N. T. 1996. The Role and Mission of African Higher Education: Preparing for the 21st Century and Beyond. *South African Journal of Higher Education*. 10 (2): 5-12.
- Atkinson, N. D. 1974. A History of Educational Policy in Southern Rhodesia. diss. London, U.K.: University of London. Ph D Thesis.
- Badenhorst, D. C. 1995. Management Tasks. In *School Management: The Task and Role of the Teacher*, ed. D. C. Badenhorst, 9-38. Pretoria: Kagiso Publishers.
- Ball, W. B. 1979. Bureaucracy Versus Religion: The Growing Threat. *Journal of Adventist Education*. 42(1, October-November): 5-7,41-42.
- Bennis, W. & Nanus, B. 1985. *Leaders: The Strategies for Taking Charge*. New York: Harper and Row.
- Bergh, A. P. & Van Wyk, J. N. 1997. Interpreting Qualitative Research Findings. In Papers Presented at Research Seminar for MEd. and DEd. Students, ed. A Moll, 60-62. Institute of Educational Research, Faculty of Education,

University of South Africa, Pretoria, May/October.

- Berkhout, S. J. 1993. Financing Education: Who Should Pay? In *Critical Issues in Modern Education*. ed. E. I. Dekker & E. M. Lemmer, 93-122. Durban: Butterworths Publishers (Pty) Ltd.
- Best, J. W. & Kahn, J. V. 1993. *Research in Education*. Boston: Allyn and Bacon.
- Bilgrami, H. H., & Ashraf. S. A. 1985. *The Concept of an Islamic University*. The Islamic Academy, Cambridge: Hodder and Stoughton.
- Blair, R. D. D. 1994. The Problem of Financing African Universities: The need for Dialogue Between the Universities and the Private Sector. Unpublished Paper. Harare.
- Blendinger, J. & Jones, L. T. 1989. Start with Culture to Improve Your School. *School Administrator*. 46 (3, May): 22-25.
- Bogdan, R. C. & Biklen, S. K. 1992. *Qualitative Research for Education: An Introduction to Theory and Methods*. Boston: Allyn and Bacon.
- Borg, W. R. & Gall, M. D. 1989. *Educational Research: An Introduction*. New York: Longman.
- Bottery, M. 1995. *The ethics of Educational Management*. London and New York: Cassel Educational Limited.
- Bradley, J. 1993. Methodological Issues and Practices in Qualitative Research. *Library Quarterly*. 63 (4, October): 431-449.
- Brantley, P. 1995. Can We Be Christian and Excellent, Too? *Journal of Research on Christian Education*. 4(1 Spring): 3-6.
- Cabel, A. S. 1993. *The University as an Institution Today*. Paris: UNESCO.
- Campbell, A. & Yeung, S. 1990. *Do You Need a Mission Statement? Special Report No. 1208. The Economist Publications Guides*. London: The Economist Publications.
- Campbell, R. F., Corbally, J. E. & Nystrand, R. O. 1983. *Introduction to Educational Administration*. Newton, Massachusetts: Allyn and Bacon Inc..
- Carr - Saunders, A. M., (Chairman). 1953. *Report of the Commission on Higher*

- Education for Africans in Central Africa Carr-Saunders Commission report.*  
Central African Council Reports 1947-1953. Salisbury.
- Carspecken, P. F. & Apple, M. 1992. Critical Qualitative research: Theory, Methodology, and Practice. In *The Handbook of Qualitative Research in Education*, ed. M. D. LeCompte, W. L. Millroy, & J. Preissle, 507-553. San Diego California: Academic Press, Inc. Harcourt Brace & Company.
- Cartmel - Robinson, H. 1951. *Cartmel - Robinson Commission Second Report.*
- Castetter, W. B. 1981. *The Personnel Function in Educational Administration.* New York: Macmillan.
- Chibanguza, A. M. 1998. From Majecha to University. Unpublished Paper Prepared by the United Methodist Church Education Secretary in Zimbabwe.
- Chivore, B. R. S. 1995. Private Tertiary Education in Zimbabwe: Current and Future Trends. Unpublished Paper prepared for The Association of African Universities. Accra-North, Ghana.
- Cochran, D. S. & David, F. R. 1986. Communication Effectiveness of Organisational Mission Statements. *Journal of Applied Communication Research.* 14 (2, Fall): 108-118.
- Collins, W. 1990. *Collins Gem English Dictionary.* London and Glasgow: William Collins Sons & Co. Ltd.
- Commission for Higher Education 1990 Model Curricula for University Education in Kenya. Nairobi: The Government Printer.
- Cooper, B. S. & Gargan, A. 1996. Private, Religious Schooling in the United States: Emerging Trends and Issues. *Journal of Research on Christian Education.* 5 (2, Autumn): 157-178.
- Covey, S. R. 1990. *The Seven Habits of Highly Effective People.* New York: Simon & Schuster.
- Crossley, M. & Vulliamy, G. 1997. Qualitative Research in Developing Countries: Issues and Experience. In *Qualitative Educational Research in Developing Countries: Current Perspectives*, ed. M. Crossley & G. Vulliamy, 1-28. New

- York and London: Garland Publishing, Inc.
- Crowley, E. P. 1995. Using Qualitative Methods in Special Education. *Exceptionality*. 5 (2): 55-69.
- Dale, R. S. 1984. Christian Schools in Secular Society. Diss. *UMI Dissertation Information Service*. Ann Arbor, Michigan: Cornell University.
- Davies, G. K. 1986. The Importance of Being General: Philosophy, Politics, and Institutional Mission Statements. In *Higher Education: Handbook of Theory and Research*., ed. J. C. Smart, 85-108. New York: Agathon Press, Inc.
- Davies, J. 1985. Institutional Mission and Purpose. In *Universities: The Management Challenge*., ed. G. Lockwood & J. Davies, 80-101. Worcester: NFER-NELSON Publishing Company Limited.
- Davies, J. 1985. Policy Formulation. In *Universities: The Management Challenge*., ed. G. Lockwood & J. Davies, 139-163. Worcester: NFER-NELSON Publishing Company Limited.
- Davies, L. 1997. Interviews and the Study of School Management: An International Perspective. In *Qualitative Educational Research in Developing Countries: Current Perspectives*, ed. M. Crossley & G. Vulliamy, 133-159. New York and London: Garland Publishing, Inc.
- De Jong, A. J. 1992. Making Sense of Church-Related Higher Education. In *New Directions for Higher Education, No. 79 (Agendas for Church-Related Colleges and Universities)* 20 (3, Fall), ed. D. S. Guthrie & R. L. Noftzger, Jr., 19-27. San Francisco: Jossey-Bass Publishers.
- Dehne, G. C. 1989. An Agenda for Small Colleges. *College Board Review*. 151 (Spring): 4,31-32.
- Dekker, E. I. & Lemmer, E. M. 1993. *Critical Issues in Modern Education*. Durban: Butterworth Publishers (Pty) Ltd.
- Deloitte & Touche Management Consultants. 1994. *Public University System in Kenya*. 1994. Final Report. Graduate Labour Market Study for the Commission of Higher Education. Nairobi: Deloitte and Touche Management

Consultants Limited. 6.

- Detomasi, D. 1995. Mission Statements: One More Time. *Planning for Higher Education*. 24 (Fall): 31-35.
- Deyhle, D. L., Hess, A. G. Jr. & LeCompte, M. D. 1992. Approaching Ethical Issues for Qualitative Researchers in Education. In *The Handbook of Qualitative Research in Education.*, ed. M. D. LeCompte, W. L. Millroy & J. Preissle, 597-641. San Diego, California: Academic Press Inc. Harcourt Brace & Company.
- Dhliwayo, J. S. 1997. Varsities Must Realise that Most People are hounded by Poverty. *The Sunday Mail Newspaper*, May, 17: 8,10.
- Doucette, D. S., Richardson, R. C. Jr. & Fenske, R. H. 1985. Defining Institutional Mission: Application of a research Model. *Journal of Higher Education*. 56 (2, March-April): 189-205.
- Dressel, P. L. 1987. Mission, Organisation and Leadership. *The Journal of Higher Education*. 58 (1 Jan-Feb):101-109.
- Duff, B. J. 1990. Women in Education Management: Barriers, Aspirations, Motivation and Needs. diss. Pretoria, South Africa: University of South Africa. D. Ed Thesis.
- Eager, H. J. 1986. A School With a Mission: Discovering a Vision for the Future. *Journal of Adventist Education*. 49(2 December-January): 28,43.
- Eastern Africa Division of Seventh-day Adventists, Education Department. 1995. *EAD Education Code*. Harare: Benaby Printing and Publishing.
- Eisenhart, M. A. & Howe, K. R. 1992. Validity in Educational Research. In *The Handbook of Qualitative Research in Education.*, ed. M. D. LeCompte, W. L. Millroy & J. Preissle, 643-680. San Diego, California: Academic Press Inc. Harcourt Brace & Company.
- Eshiwani, G. S. 1993. *Education in Kenya: Since Independence*. Nairobi: East African Educational Publishers.
- Evans, B. 1990. Community College Mission and Goals Development: A

- process-Oriented Approach. *Community College Review*. 18 (3, Winter): 7-11.
- Everard, B. & Morris, G. 1990. *Effective School Management*. London: Paul Chapman Publishing Ltd.
- Fidel, R. 1993. Qualitative Methods in Information Retrieval Research. *Library Information Science*. 15 (3, Summer): 219-247.
- Fisher, B. C. 1989. *The Idea of a Christian University in Today's World*. Macon, Macon, Georgia: Mercer University Press.
- Fowler, J. M. 1994. The Mission School: Catalyst or Catastrophe? *Journal of Adventist Education*. 56(2 December-January): 37-40.
- Furst, L. G. 1992. State Control of Non-Governmental Schools: A Comprehensive Review of Case Law. *Journal of Research on Christian Education*. 1 (1, Autumn): 103-116.
- Gall, M. D., Borg, W. R. & Gall, J. P. 1996. *Educational Research: An Introduction*. New York: Longman Publishers USA.
- Garug'e A. W. P. & Berstecher, D. G. 1984. *Principles and Problems of Educational Management*. Paris: UNESCO Publishing.
- Gillian, J. E. 1984. The Institute for Christian Leadership Goals and Mission. *Faculty Dialogue*. (1 Fall): 87-96.
- Gliner, J. A. 1994. Reviewing Qualitative Research: Proposed Criteria for Fairness and Rigour. *Occupational Therapy Journal of Research*. 14 (2, Spring): 78-90.
- Government of Kenya. 1980. *The Education Act*. Revised Edition of 1970. Nairobi: Government Printer.
- Government of Kenya. 1989. *The Universities (Establishment of Universities) (Standardisation, Accreditation and Supervision) Rules*. Kenya Gazette Supplement No. 9, Legal Notice No. 56. Nairobi: Government Press.
- Government of Rhodesia. 1979. Rhodesia Education Act. No. 8. In *The Statute Law of Rhodesia*, 171- 203. Salisbury: Government Printer.
- Government of Uganda. 1997. The National Council for Higher Education. Draft Act. Kampala.

- Government of Zimbabwe. 1990. *National Council of Higher Education*. Act Establishing the National Council of Higher Education. No. 32. Harare: Government Printer.
- Graham, D. A. 1963. The Church on Earth. In *The Teaching of the Catholic Church: A Summary of Catholic Doctrine.*, ed. G. S. Smith, 691-732. London: Burns and Oates.
- Griffin, P. R. 1984. *Black Theology as the Foundation of the Methodist College: The Educational Views of Daniel Payne, Joseph Price and Isaac Lane*. Lanham MD: University Press of America
- Grobman, A. B. 1980. The Missions of Urban Institutions. *Liberal Education*. 66 (2, Summer): 200-207.
- Gross, S. 1987. The Power of Purpose. *Child Care Information Exchange*. (56, July): 25-29.
- Guthrie, D. S. 1992. Mapping the Terrain of Church-Related Colleges and Universities. In *New Directions for Higher Education, No 79 (Agendas for Church-Related Colleges and Universities 20 (3, Fall)*, ed. D. S. Guthrie, & R. L. Noftzger, Jr., 3-18. San Francisco: Jossey-Bass Publishers.
- Hagstrom, S. & Steen, A. 1995. The University of Africa in the 1990's and Beyond: The Changing Role of the University. Keynote Address. Joint Colloquium on the University in Africa in the 1990's and Beyond. National University of Lesotho, Roma, Lesotho.
- Hammersley, M., Gomm, R. & Woods, P. 1994. *Study Guide for Educational Research Methods*. Milton Keynes: Open University.
- Harber, C. 1997. Using Documents for Qualitative Educational Research in Africa. In *Qualitative Educational Research in Developing Countries: Current Perspective*, ed. M. Crossley & G. Vulliamy, 113-131. New York and London: Garland Publishing, Inc.
- Harvey, M. & 1994. *Stage Four - Strategic Management Accountancy and Marketing - Practical Elements*. London: The Chartered Institute of Management

Accountants.

- Hasselkus, B. R. 1995. Beyond Ethnography: Expanding Our Understanding and Criteria for Qualitative Research. *Qualitative Therapy Journal of Research*. 15 (2, spring): 75-84.
- Hayward, G. C. 1986. Mitigating Chaos: California's Community colleges in the Post-Proposition 13 Period. In *New Directions for Higher Education: Crisis Management in Higher Education.*, ed. H. Hoverland, P. McInturff & T. C. Rohm, E. Jr., 25-32. San Francisco: Jossey-Bass Inc., Publishers.
- Herald Correspondent. 1995. Local Private University Students to get State Aid. *The Herald*, December 7: 4.
- Herman, J. 1989. Site-Based Management: Creating a Vision and Mission Statement. *NASSP Bulletin*. 73 (519): 79-83.
- Hersey, P. & Blanchard, K. 1982. *Management of Organisational Behaviour: Utilising Human Resources*. Englewood Cliffs, New Jersey: Prentice-Hall, Inc.
- Hill, B. V. 1982. Christian Schools: Issues to be Resolved. *Journal of Christian Education*. (Papers 75, November):5-17.
- Hinchliffe, K. 1987. *Higher Education in Sub-Saharan Africa*. Worcester, London: Billing & Sons Limited.
- Hines, E. R. 1988. *Higher Education and the State Governments: Renewed Cooperation, or Competition?* ASHE-ERIC Higher Education Reports No. 5. Washington, D. C.: Association for the Study of Higher education
- Hoberg, S. M. 1997. The Educational Management of the Pre-primary School: The Bipartite Role of the Teaching Principal. *Educare*. 26 (1&2): 35-45.
- Holmes, A. F. 1989. *The Idea of a Christian College*. Grand Rapids, Michigan: William B. Eerdmans Publishing Company.
- Hopkin, A. G. 1992. Qualitative Research Methodology: A Cross Cultural Perspective. *Compare: A Journal of Comparative Education*. 22 (2): 133-141.
- Hornby, A. S. 1995. *Oxford Advanced Learners' Dictionary of Current English*. London: Oxford University Press.



- Hoverland, H., McInturff, P. & Rohm, T. C. E. Jr. 1986. The Crisis Prevention Analysis Model. In *New Directions for Higher Education: Crisis Management in Higher Education.*, ed. H. Hoverland, P. McInturff & T. C. Rohm, E. Jr., 33-41. San Fransisco: Jossey-Bass Inc., Publishers.
- Hoy, W. K. 1982. Recent Developments in Theory and Research in Educational Administration. *Educational Administration Quarterly.* 18 (3, Summer): 1-11.
- Hultigren, F. 1993. A Hermeneutical Challenge to the Methodological Mentality in Qualitative Inquiry. *Journal of Vocational Education Research.* 18 (2): 21-42.
- Husain, S. S., and Ashraf, S. A. 1979. *Crisis in Muslim Education.* King Abdulaziz University, Jeddah: Hodder and Stoughton.
- Ingalis, Z. 1987. Balancing A Baptist Tradition and the Liberal Arts. *Chronicle of Higher Education.* 33 (17, Jan 7): 3.
- Institution C Act. 1990. *The Institution C Statute, 1990.* Statute No. 8 1990: 77-118. (Identity Protected)
- Institution F. 1995-1996. *Institution F Bulletin.* A Bulletin. Bulawayo: Alpha Print (PVT.) LTD. (Identity protected)
- Institution G. 1995-1997. *Institution G. 1995-1997 Prospectus.* Nairobi: Printfast Kenya Ltd. (Identity protected)
- Institution K. 1997. The Mission of Institution K. Unpublished Statement of Mission for Institution K. Nairobi. (Identity protected)
- Institution L Act 1992. 1992. *Statutory Instrument 29 of 1992* Act No. 32/90: 113-132. (Identity protected)
- Institution L. 1997. Fact Sheet for Faculty of Theology. Information Office for Institution L.
- Ishoy, K. C., & Swan, P. D. 1992. Creating a Mission Statement for Your Work Group: A Guide for Managers and Supervisors. *Performance and Instruction.* 30 (10 November/December): 11-15.
- Jaqua, C. L. 1977. Should Church Schools Receive Government Aid? *Journal of Adventist Education.* 40(1 October-November): 16-18, 24-25.

- Jansen, G. & Peshkin, A. 1992. Subjectivity in Qualitative Research. In *The Handbook of Qualitative Research in Education*, ed. M. D. LeCompte, W. L. Millroy & J. Preissle, 681-725. San Diego, California: Academic Press Inc. Harcourt Brace & Company.
- Kamunge, J. M. (Chairman). 1988. *Report of the Presidential Working Party on Education and Manpower Training for the Next Decade and Beyond*. Presented to His Excellency Hon. Daniel T. Arap Moi, C. G. H., M. P. President and Commander-in-Chief of the Republic of Kenya. Nairobi: Government Press.
- Kennedy, D. 1991. Planning for Stanford's Next Twenty Years. *Planning for Higher Education*. 19 (2 Winter): 6-10.
- Kibuuka, H. E. 1987. The Relationship Between Finance and the Academic Performance of Private Secondary Schools in Uganda. diss. Kampala, Uganda: Makerere University, Med Dissertation.
- Kimbrough, R. B. & Nunnery, M. Y. 1983. *Educational Administration: An Introduction*. New York: Macmillan Publishing Co., Inc.
- Kirkermo, R. 1997. Point Loma Nazarene College: Modernisation in Christian Higher Education. In *Models for Christian Higher Education: Strategies for Success in the Twenty-First Century*, ed. R. T. Hughes & W. B. Adrian. 346-364. Grand Rapids, Michigan: William B. Eardmans Publishing Company.
- Klimoski, V. J. 1991. From Brochure Copy to a Sense of Purpose: Recapturing the Value of Mission. *Adult Learning*. 3 (2, October): 19-20, 27-28.
- Knott, J. B. M. 1995. A Study of the Management Problems and Possible Solutions in State-Aided Schools. diss. Pretoria, South Africa: University of South Africa. D.Ed Thesis.
- Knoop, R. 1986. Setting and Achieving Objectives. *Education Canada*. 12-15.
- Kohler, P. 1985. Workshop Report: Institutional Mission and Strategy. *International Journal of Institutional Management in Higher Education*. 9(3 November): 344-350.

- Kolde, E. 1977. Management of Education. In A. S. Knowles (Ed.) *The international Encyclopaedia of Higher Education*. 6: 2692-2704. San Francisco: Jossey-Bass.
- Konrad, A. G., & McNeal, J. 1984. Goals in Canadian Universities. *Canadian Journal of Higher Education*. 14 (1): 31-40.
- Koontz, H. D. & O'Donnell, C. J. 1964. *Principles of Management: an Analysis of Managerial Functions*. New York: McGraw-Hill
- Kotler, P. & Murphy, P. E. 1981. Strategic Planning for Higher Education. *Journal of Higher Education*. 52 (5): 470-489.
- Lang, D. W. & Lopers-Sweetman, R. 1991. The Role of Statements of Institutional Purpose. *Research in Higher Education*. 32 (6, December): 599-624.
- Laramee, W. A. 1987. The Role of Metaphors in Higher Education. *College Board Review*. (143, Spring): 18-19; 33-34.
- Lawler, E. E. III. 1986. *High Involvement Management*. San Francisco: Jossey-Bass Inc., Publishers
- Lemmer, E. M. 1989. The Reentry of Women into the Labour Market and the Implications for Educational Provision. diss. Pretoria, South Africa: University of South Africa. D. Ed Thesis.
- Lemmer, E. M. 1992. Qualitative Research Methods in Education. *South African Journal of Education*. 12 (3): 292-296.
- Lewis, J. Jr. 1989. *Implementing School-Based Management: by Empowering Teachers*. Jericho, New York: J. L. Wilkerson Publishing Co. Ltd.
- Lewis, L. M. 1984. Do Small SDA Schools Have a Future? *Journal of Adventist Education*. 46 (3, February-March): 24-25, 37.
- Lewis, L. M. 1996. Book Review: Religion and American Education: A National Dilemma, by W. Nord. *Journal of Research on Christian Education*. 5 (1 Spring): 102-106.
- Mackay, K. A., & Schuh, J. H. 1991. Practical Issues Associated with Qualitative Research Methods. *Journal of College Student Development*. 32 (5,

- September): 424-432.
- Maphosa, N. 1996. An Investigation Into the Factors Leading to the Establishment of Private Universities in Zimbabwe. Dissertation Proposal. University of Zimbabwe. A Doctoral of Philosophy Degree Dissertation Proposal.
- Manning, K. 1997. Authenticity in Constructivist Inquiry: Methodological Considerations Without Prescription. *Qualitative Inquiry*. 3 (1, March): 93-115.
- Matejka, K., Kurke, L. B. & Gregory, B. 1993. Mission Impossible?: Designing a Great Mission Statement to Ignite Your Plans. *Management Decision*. 31 (4): 34-37.
- Mbamba, A. M. 1992. *Book of Readings in Educational Management*. Harare: UNESCO.
- McClelland, V. A. 1988. 'Sensus Fidelium': The Developing Concept of Roman Catholic Voluntary Efforts in Education in England and Wales. In *Christianity and Educational Provision in International Perspective.*, ed. W. Tulasiewicz & C. Brock. 61-88. London and New York: Routledge.
- McDonough, K. F., & Noonan, B. 1994. The Mission Statement: A Process not a Product. *Education Canada*. 34 (Fall): 10-13, 37.
- McGinnis, V. J. 1981. The Mission Statement: A Key Step in Strategic Planning. *Business*. (November-December): 39-43.
- McKelvie, B. D. 1986. The University's Statement of Goals. *Higher Education*. 15: 151-163.
- McMillan, J. H. & Schumacher, S. 1993. *Research in Education: A Conceptual Introduction*. New York: Harper Collins College Publisher.
- Merriam-Webster, A. 1980. *Webster's New Collegiate Dictionary*. Springfield, Massachusetts: D. & C. Merriam Company.
- Miles, M. B., & Huberman, A. M. 1994. *Qualitative Data Analysis: An Expanded Sourcebook*. Thousand Oaks, California: Sage Publications, Inc.
- Ministry of Education and Culture. 1988. Educational Administration and

- Management. Module 04. Harare: Distance Education Centre.
- Ministry of Education. 1989. *Education for National Integration and Development (White Paper)*. Report of Education Review Commission. Kampala: Marianum Press.
- Ministry of Education. 1996. The Universities Act. A Draft. Kampala.
- Moore, D. R. 1986. Stewardship of Resources for Private Higher Education. In *New Directions for Higher Education: Crisis Management in Higher Education.*, ed. Pat Hoverland, Pat McInturff and Tapie C. Rohm, E. Jr., 17-23. San Francisco: Jossey-Bass Inc., Publishers.
- Morgan, C. 1976. *Management in Education - Dissimilar or Congruent*. A Third Level Course in Education, unit 1. Milton Keynes, Walton Hall: Open University Press.
- Morse, M. T. 1994. Just What is Qualitative Research?: One Practitioner's Experience. *Journal of Visual Impairment and Blindness*. 88 (1, Jan-Feb): 43-52.
- Moseley, J. D. 1980. The Mission of the Church-Related College. *Liberal Education*. 66 (2, Summer): 177-182.
- Mouritsen, M. E. 1986. The University Mission Statement: A Tool for the University Curriculum, Institutional Effectiveness, and Change. In *New Directions for Higher Education: Crisis Management in Higher Education.*, ed. H. Hoverland, P. McInturff & T. C. E. Rohm, Jr., 43-52. San Francisco: Jossey-Bass Inc., Publishers.
- Mutumbuka, D. B. (Minister of Higher Education, Zimbabwe) 1989. Policies for Higher Education in Zimbabwe: Alternatives to the World Bank Perspective. *Zimbabwe Journal of educational Research*. 1(1, March): 43-70.
- National Council for Higher Education. 1997. Minutes of the Zimbabwe National Council for Higher Education, November 21, 1997, Harare.
- Newman, F. 1987. *Choosing Quality: Reducing Conflict between the State and the University*. Denver: Education Commission of the States.

- Newson, W. & Hayes, C. R. 1990-91. Are Mission Statements Worthwhile? *Planning for Higher Education*. 19(2 Winter): 28-30.
- Oberholzer, M. O., Landman, W. A., Higgs, P., Roelofse, J. J., Swanepoel, E. M., & Barnard, F. Contributors. 1993. *Philosophy of Education*. Study Guide for OFO411-K. Pretoria: University of South Africa.
- Odhiambo, T. R. 1996. The Pursuit of Excellence and Relevance in the Context of Africa' Future. Unpublished Graduation Keynote Address. University of Eastern Africa, Baraton; Kenya.
- Opika Opoka, H. S. 1995. Establishment of New Tertiary Institutions and Universities. Letter. Kampala: Unpublished Guidelines.
- Ormalala, E. 1994. Impact Assessment: European Experience of Qualitative Methods and Practices. *Evaluation Review*. 18 (1, February): 41-51.
- Orora, J. H. O. 1992. Doing Qualitative Research in Kenya: Reflections on Some Problems and Strategies of Three Qualitative Research Methods. *MJEAS*. 1 (1): 31-46.
- Ozmon, H. A., & Craver, S. M. 1986. *Philosophical Foundations of Education*. Columbus: Merrill Publishing Company.
- Parker, B. 1986. Agreement on Mission and Institutional Responses to Decline. *Research in Higher Education*. 25 (2): 164-181.
- Passi, F. O., Olal-Odur, A & Kibuuka, H. E. 1996. *Foundations of Education: Educational Administration*. Kampala: Institute of Adult and Continuing Education, Department of Distance Education, Makerere University.
- Pearce, J. A. 1982. The Company Mission As a Strategic Tool. *Sloan Management Review*. 23 (3 Spring): 15-24.
- Peeke, G. 1990. Educational Establishments and Institutional Mission. *Management in Education*. 4 (4, Winter): 5-6.
- Peshkin, A. 1988. In Search of Subjectivity - One's Own. *Educational Researcher*. 17(7): 17-22.
- Peters, T. J. & Austin, N. 1985. *A Passion for Excellence*. London: Collins.

- Rasi, H. M. 1994. A Matter of Mission. *Journal of Adventist Education*. 56(5 Summer): 3.
- Rasi, H. M. 1998. Foundational Concepts in Seventh-Day Adventist Education: A Rationale for Adventist Education. Unpublished paper presented by World Leader of Seventh-day Adventist Education Department to the Education Leadership Seminar, Africa, March 16-20, 1998. Somerset West, Republic of South Africa.
- Remenyi, D. & Money, A. 1996. A Practical Guide to Preparing Academic Papers. *South African Journal of Higher Education*. 10 (2): 208-217.
- Republic of Kenya. 1984. *Higher Education in Kenya: With Special Reference to University Education*. Second Report of the 1980-1983 University Grants Committee. Nairobi: The Government Printer.
- Republic of Kenya. 1989. *Development Plan 1989-1993*. Nairobi: Government Printer.
- Republic of Kenya. 1996. *National Development Plan 1997-2001*. Nairobi: The Government Printer.
- Reynolds, R. L. 1980. Government Intrusion in Higher Education. *Journal of Adventist Education*. 42(3 February-March): 14-15, 27-29.
- Richards, L. & Richards, T. 1991. Computing in Qualitative Analysis: A Healthy Development. *Qualitative Health Research*. 1 (2 May): 234-262.
- Riffel, J. A. 1978. The Theory Problem in Educational Administration. *The Journal of Educational Administration*. 16(2 October): 139-149.
- Ringenberg, W. C. 1987. The old-Time College, 1800-1865. In *Making Higher Education Christian*. Ed., J. A. Carpenter and K. W. Shipps. Grand Rapids, Michigan: Christian College Consortium and Eardmans.
- Rogus, J. F. 1990. Developing a Vision Statement - Some Considerations for Principals. *NASSP Bulletin*. 74 (523 February): 6-12.
- Roy, L. 1991. What is Qualitative Research? *Journal of Youth Services in Library*. 5 (1, Fall): 105-107.

- Saayman, W. 1991. 'Who Owns The Schools Will Own Africa': Christian Mission, Education and Culture. *Journal of the Study of Religion*. 4 (2, September): 29-44.
- Saint, W. S. 1992. *Universities in Africa: Strategies for Stabilisation and Revitalisation*. World Bank Technical Paper Number 194: Africa Technical Department Series. Washington, D.C.: The World Bank.
- Sanyal, B. C., Martin, M. & D'Antoni, S. 1996. *Institutional Management in Higher Education: Issues, Trends and International Experiences*. IIEP Teaching Materials Module 1 for The Institute of Management in Higher Education. Paris: UNESCO International Institute for Educational Planning.
- Schwerin, U. C. 1980. Institutional Mission in an Era of Retrenchment: New York City Community College, CUNY. *Liberal Education* 66 (2, Summer): 169-176.
- Seraphin, E. 1997. Leadership and Management. Paper Presented to Association of African Universities 9<sup>th</sup> AAU General Conference. Lusaka, Zambia, 13-17 January.
- Siyakwazi, B. J. 1995. Church and State Partnership in African Education in Colonial Zimbabwe. *Zimbabwe Journal of Educational Research*. 7 (3, November): 323-342.
- Smith, T. L. 1987. Introduction: Christian Colleges and American Culture. In *Making Higher Education Christian: The History and Mission of Evangelical Colleges in America*, edited by J. A. Carpenter & K. W. Shipps, 6-15. Grand Rapids, Michigan: William. B. Eardamans Publishing Company.
- Stanley, J. E. & Stanley, S. C. 1997. What Can the Wesleyan/Holiness Tradition Contribute to Christian Higher Education. In *Models for Christian Higher Education: Strategies for Success in the Twenty-First Century*, ed. R. T. Hughes & W. B. Adrian, 313-326. Grand Rapids, Michigan: William B. Eardmans Publishing Company.
- Steckler, A., McLeroy, K. R., Goodman, R. M., Bird, S. T. & McCormick, L. 1992.



- Toward Integrating Qualitative and Quantitative Methods: An Introduction. *Health Education Quarterly*. 19 (1, Spring): 1-8.
- Stockey, A. 1983. The Case for Christian Schools. *Spectrum*. 16 (1, Autumn): 4-14.
- Stott, K. & Walker, A. 1992. The Nature and use of Mission Statements in Singaporean Schools. *Educational Management and Administration*. 20 (1, January): 49-57.
- Streharsky, C. J. 1991. Evolution of the University Research Mission in the United States. *Research Management Review*. 5 (1, Spring): 35-50.
- Strydom, A. H. 1988. University Leadership and Management in the RSA. *Rand Afrikaans University*. 20 (2, December):1-14.
- Strydom, A. H., & Bitzer, E. M. 1987. Perspectives on University Management. *Rand Afrikaans University: Bulletin for University Teachers*. 19 (3):12-27.
- Strydom, A.H. 1989. *Mission Formulation and Reformulation at Tertiary Education Institutions with Particular Reference to Universities*. A Manual. Bloemfontein: Bureau for University Education, University of Orange Free State.
- Sutton, B. 1993. The Rationale for Qualitative Research: A Review of Principles and Theoretical Foundations. *Library Quarterly*. 63 (4, October): 411-430.
- Teese, R. 1989. The Political Functions of the Central Administration of Catholic Education in France. *Journal of Education Policy*. 4 (2): 103-114.
- The Working Committee of Institution J. 1991. Institution J. Unpublished Proposal to Establish Institution J Submitted to the Secretariat of The Commission for the Higher Education. Nairobi. (Identity protected)
- The University Act. 1994, Charter for Institution I. Legal Notice 373 (Cap 210B) Republic of Kenya. 909-934. (Identity protected)
- Thelin, J. R. 1986. Postscript of "The Importance of Being General" by Gordon K. Davies. In *Higher Education: Handbook of Theory and Research*, ed. J. C. Smart 103-108. New York: Agathon Press, Inc.
- Thompson, A. A. Jr., & Strickland, A. J. III. 1986. *Strategy Formulation and*

- implementation: Tasks of the General Manager*. Plano, Texas: Business Publications, Inc.
- Tierney, W. G. 1988. Organisational Culture in Higher Education: Defining the Essentials. *Journal of Higher Education* 59 (1 January/February): 2-21.
- Tierney, W. G. & Lincoln, Y. S. 1994. Teaching Qualitative Research Methods in Higher Education. *The Review of Higher Education*. 17 (2, Winter): 107-124.
- Torgerson, R. L. 1991. Assessing Student Academic Achievement: Bethany College. *NCA Quarterly*. 66 (2, Fall): 477-480.
- Treister, E. S. 1992. School Mission and School Success. Diss. *Journal of Research on Christian Education*. 1(1 Autumn): 130.
- Trewatha, R. G. & Newport, M. G. 1976. *Management: Functions and Behaviour*. Dallas: Business Publications.
- Tuckman, B. W. 1994. *Conducting Educational Research*. Fort Worth: Harcourt Brace College Publishers.
- Van der Westhuizen, P. C. 1991. Educational Management Tasks. In *Effective Educational Management*, ed. P. C. Van der Westhuizen, 135-235. Pretoria: HAUM Tertiary.
- Van der Westhuizen, P. C. 1991. Perspectives on Educational Management and Explanation of Terms. In *Effective Educational Management*, ed. P. C. Van der Westhuizen, 11-61. Pretoria: HAUM Tertiary.
- Van der Westhuizen, P. C. 1991. The Development of Scientific Management Thought and Some Developments in the Field of Educational Management. In *Effective Educational Management*, ed. P. C. Van der Westhuizen, 63-132. Pretoria: HAUM Tertiary.
- Van Niekerk, W. P. 1988. *Contemporary Management*. Durban: Butterworths.
- Van Schalkwyk, O. J. 1989. Introduction: From the Universal to the Individual. In *Modern Education Systems*, ed. E. Dekker & O. J. Van Schalkwyk, 1-17. Durban: Butterworths.
- Van Schalkwyk, O. J. 1993. *The Education System: Theory and Practice*. Pretoria:

Alkanto Publishers.

- Van Wyk, C. 1994. Management Tasks, Roles, Areas and Levels. Study Guide 3 for ONB451-F. Pretoria: University of South Africa.
- Vaughan, G. B. 1984. Forging the Community College Mission. *Educational Record*. 65 (3, Summer): 24-29.
- Watson, K. & MacKenzie, P. 1996. The New Christian Schools in England and Wales: An Analysis of Current Issues and Controversies. *Journal of Research on Christian Education*. 5 (2, Autumn): 179-208.
- Webb-Mitchell, B. 1992. The Promises and Problems of Ethnography in Religious Education. *Religious Education*. 87 (2, Spring): 246-258.
- Westbrook, L. 1994. Qualitative Research Methods: A review of Major Stages, Data Analysis Techniques, and Quality Controls. *Library and Information Science Research*. 16 (3, Summer): 241-254.
- Wheatley, M. J. 1994. *Leadership and the New Science: Learning about Organisations from an Orderly Universe*. San Francisco: Berrett Koehler Publishers, Inc.
- Whitt, E. J. 1991. Artful Science: A Primer on Qualitative Research Methods. *Journal of College Student Development*. 32 (5, September): 406-415.
- Williams, P. R. C., (Chairman). 1989. Report of the Commission of Inquiry into the Establishment of a Second University or Campus. Report of the Commission. Harare, Zimbabwe.
- Wilson, B. L., & Corcoran, T. B. 1988. *Successful Schools: Visions of Excellence in American Public Education*. London: The Falmer Press.
- Wilson, H. S. & Hutchinson, S. A. 1991. Triangulation of Qualitative Methods: Heideggerian Hermeneutics and Grounded Theory. *Qualitative Health Research* 1 (2, May): 263-276.
- Winter, D. K. 1987. Rendering unto Caesar: The Dilemma of College-Governmental Relations. In *Making Higher Education Christian: The History and Mission of Evangelical Colleges in America.*, ed. J. A. Carpenter & K. A. Shipps,

- 244-253. Grand Rapids, Michigan: Wm. B. Eardamans Publishing Company.
- Wolcott, H. F. 1990. On Seeking - and rejecting - validity in Qualitative Research. In *Qualitative Inquiry in Education: The Continuing Debate*, ed. E. W. Eisner, & A. Peshkin, 121-152. New York: Teachers College Press.
- Wolcott, H. F. 1992. Posturing in Qualitative Inquiry. In *The Handbook of Qualitative Research in Education.*, ed. M. D. LeCompte, W. L. Millroy & J. Preissle, 3-52. San Diego, California: Academic Press, Inc. Harcourt Brace & Company.
- Wolpe, H. 1995. The Debate of University Transformation in South Africa: The Case of the University of the Western Cape. *Comparative Education*. 31 (2, June): 275-292.
- Wynn, D. W. 1975. *The Protestant Church-Related College: A Handbook for Presidents and Trustees*. New York: Philosophical Library, Inc.
- Yarrington, R. 1981. Money and Mission: A Report of 5 Round Tables on the Brookings Study. *Community and Junior College Journal*. 51 (8, May): 19-21.



CHART 10.1  
PRESENT ORGANISATION STRUCTURE OF  
MINISTRY OF EDUCATION (1988)

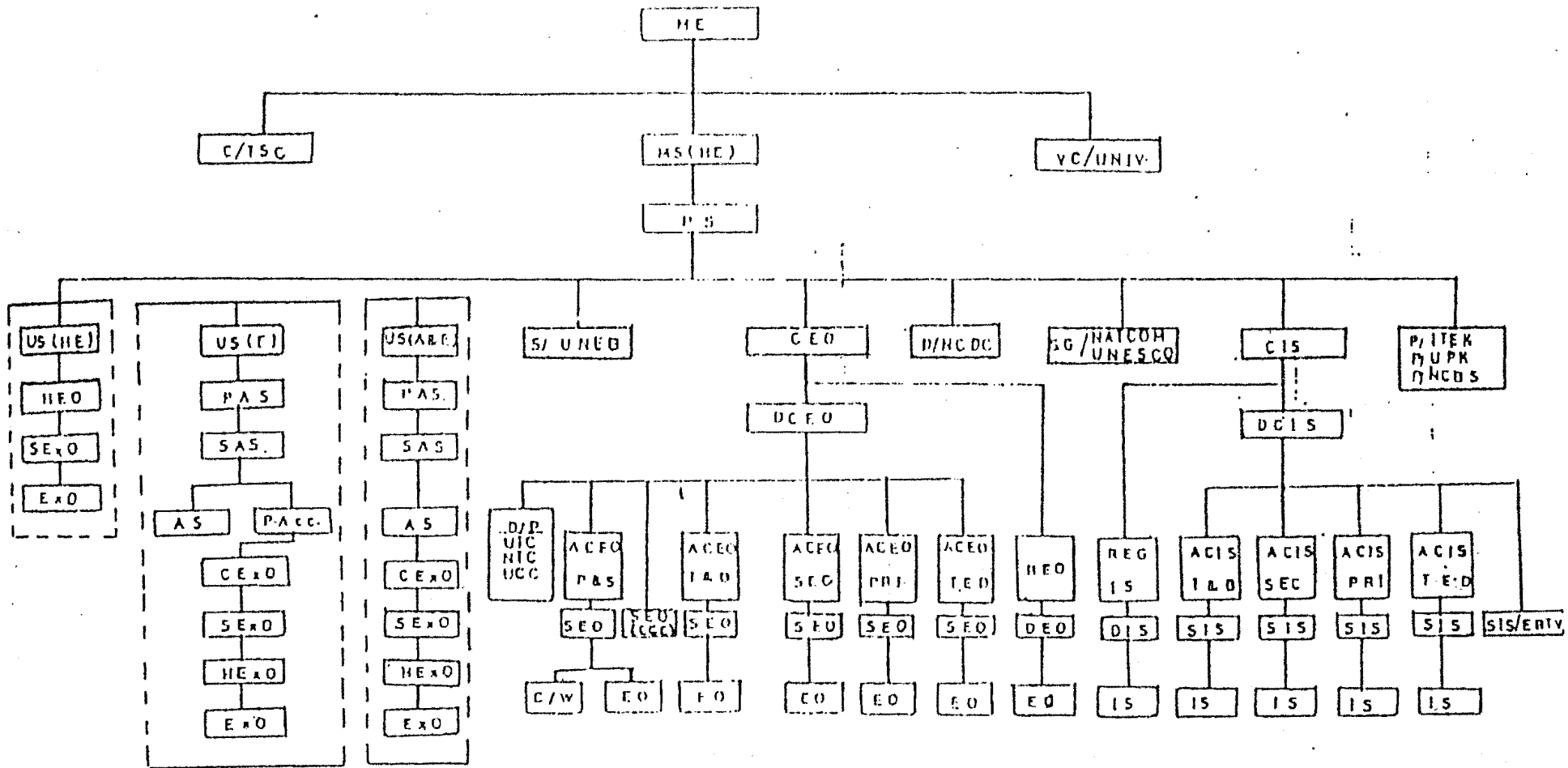

Source: (Ministry of Education 1989: 131)

CHART 10-2  
 PROPOSED ORGANISATION STRUCTURE  
 OF MINISTRY OF EDUCATION

APPENDIX A3

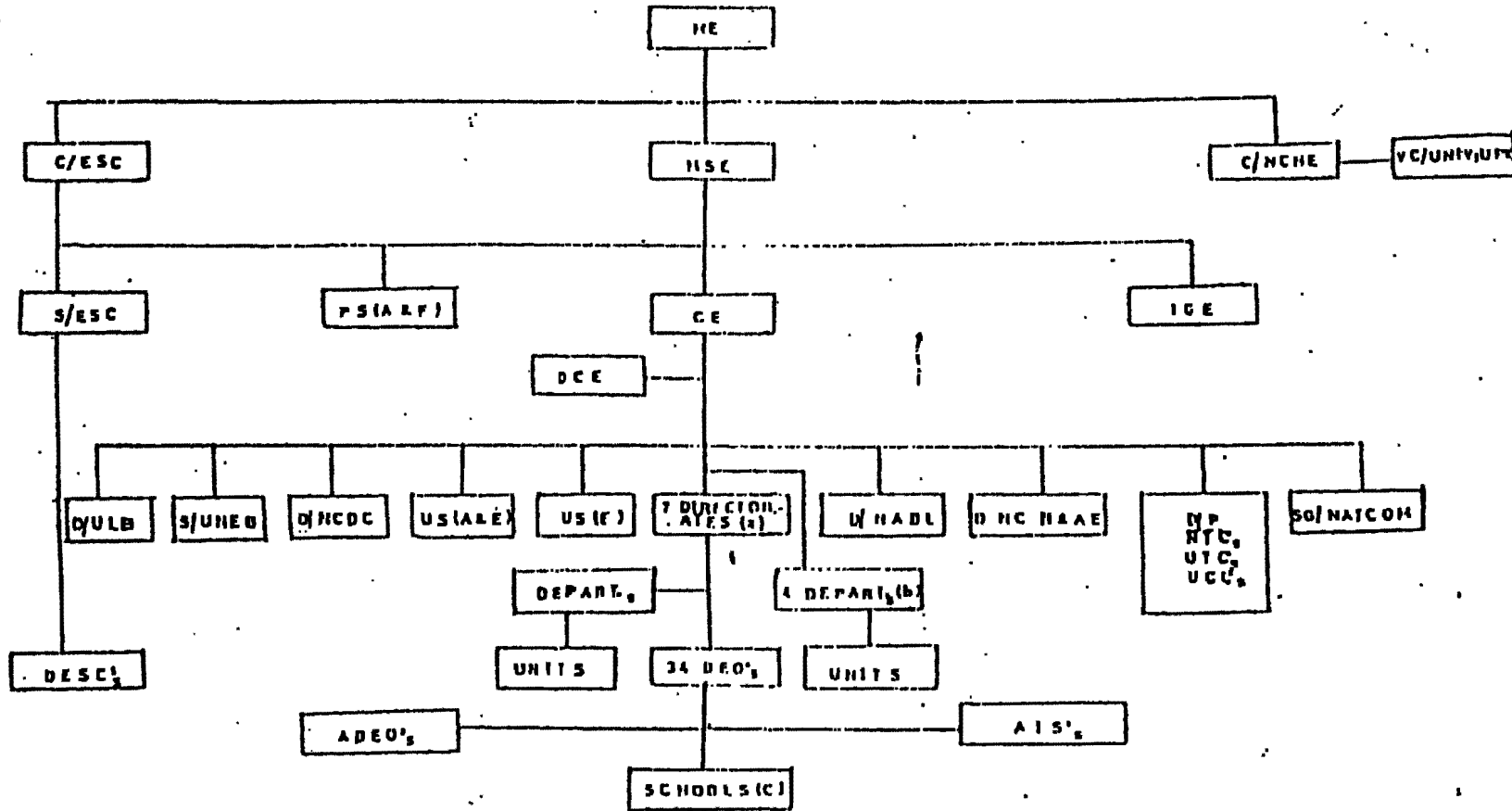

Source: (Ministry of Education 1989: 132)

320

**NOTE:**

- (a) Directorates of Pre-primary and Primary Education; Secondary Education; Higher Education; Technical and Vocational Education; Teacher Education; Non-Formal and Adult Education; and Planning, Statistics and Evaluation.
- (b) Departments of School Buildings and Facilities; Guidance and Counselling; Special Education and Private Schools.
- (c) Schools and Institutions up-to Secondary Level.

**Abbreviations for Appendices A2 and A3**

ME:	Minister of Education
MSE:	Minister of State for Education
VC:	Vice-Chancellor
PS:	Permanent Secretary
US:	Under Secretary
C:	Chairman
D:	Director
P:	Principal
S:	Secretary
DEO:	District Education Officer
CEO:	Chief Education Officer
DCEO/ACEO:	Deputy CEO/Assistant CEO
CIS:	Chief Inspector of Schools
DCIS/ACIS:	Deputy CIS/Assistant CIS
SEO/EO:	Senior Education Officer/education Officer
REO:	Regional Education Officer
SIS:	Senior Inspector of Schools
DIS/IS:	District Inspector of Schools/Inspector of Schools
PAS:	Principal Assistant Secretary
SAS/AS:	Senior Assistant Secretary/ Assistant Secretary
CexO/SExO/HExO:	Chief/Senior/Higher Executive Officers
ExO:	Executive Officer
P.Acc:	Principal Accountant
C/W:	Clerk of Works
HE:	Higher Education
TSC:	Teaching Service Commission
F:	Finance
A&E:	Administration & Establishment
P&S:	Planning & Statistics



T&B:	Technical & Business Education
Pri:	Primary
Sec:	Secondary
T.ED:	Teacher Education
CGC:	Career Guidance & Counselling
ERTV:	Educational Radio and Television
NATCOM:	National Commission for UNESCO
CE:	Commissioner of Education
IGE:	Inspector General of Education
DCE:	Deputy Commissioner of Education
ESC:	Education Service Commission
DESC:	District Education Service Committee
ADEO/AIS:	Assistant DEO/Assistant Inspector of Schools

MINISTRY OF HIGHER EDUCATION: TOP ORGANISATIONAL STRUCTURE CHART: HEAD OFFICE

APPENDIX A4

323

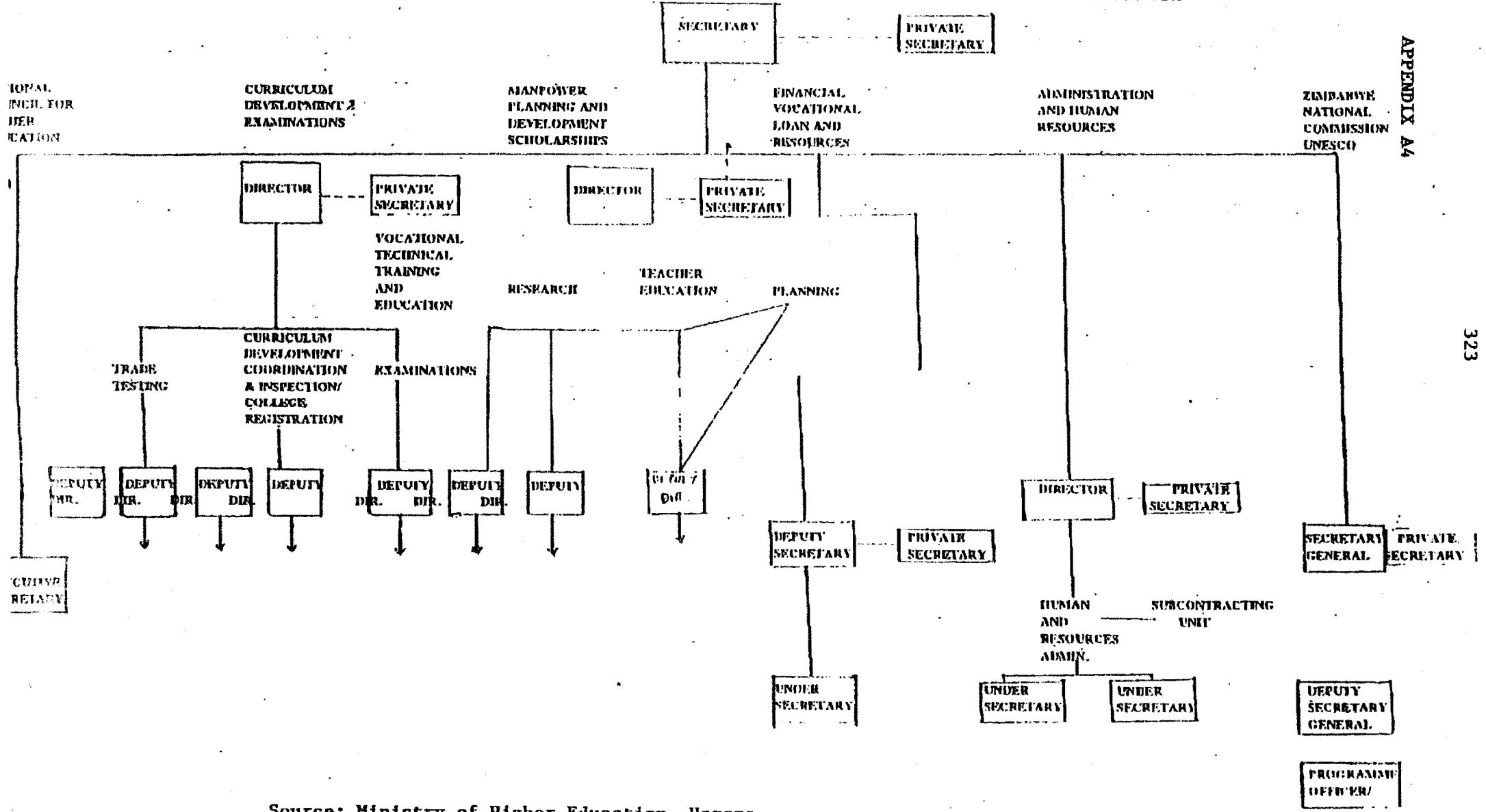

Source: Ministry of Higher Education, Harare



**OFFICE OF THE PRESIDENT**  
**PROVINCIAL ADMINISTRATION AND INTERNAL SECURITY**

Telegraphic Address: "Rais"  
Telephone: Nairobi 227411  
When replying please quote

Ref. No. OP/13/001/26C 214  
and date

Personnel Division  
P.O. Box 30510  
Nairobi

7th April, 1997

Hudson E. Kibuuka  
Eastern Africa Division  
P.O. Box HG 100  
HIGHLANDS, HARARE  
ZIMBABWE.

Dear Sir,

**RE: TEMPORARY RESEARCH PERMIT.**

I acknowledge receipt of your application documents dated 26th September, 1997 and while the final decision <sup>on your</sup> research application has not been made, I am pleased to inform you that you have been granted a temporary research permit for one year beginning April 1997 to April 1998 to conduct research on mission statement and management of tertiary Religious institutions in Eastern and Southern Africa.

It is noted that the Research will be conducted in Nairobi.

Please note that this temporary Research permit will be withdrawn when you are issued with a normal research permit.

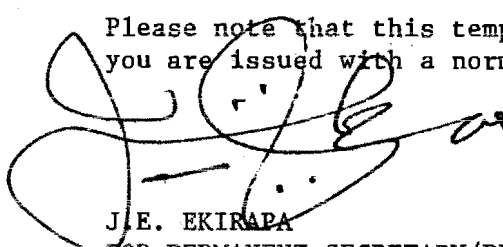

J. E. EKIRAPA  
FOR PERMANENT SECRETARY/PROVINCIAL ADMINISTRATION

cc The Provincial Commissioner  
NAIROBI.

325  
UGANDA NATIONAL COUNCIL FOR SCIENCE  
AND TECHNOLOGY

APPENDIX B2  
TELEPHONES: 250499 (General)  
EXECUTIVE SECRETARY'S DIRECT LINE: 250431  
TELEX NO \_\_\_\_\_ TELEFAX NO. 234579.

76 BUGANDA ROAI  
P.O. BOX-6884  
KAMPALA, UGAND.

Your Ref: \_\_\_\_\_

Date 27-June 19 97

Our Ref: SS 1048

The Resident District Commissioner  
Kampala district,  
P. O. Box 352  
Kampala.

Dear Sir/Madam,

RE: RESEARCH CLEARANCE

This is to introduce Hudson Eddie Kibuuka  
who would like to carry out research on MISSION STATEMENT AND  
MANAGEMENT OF TERTIARY RELIGIOUS INSTITUTIONS IN EASTERN AND SOUTHERN  
AFRICA

for a period of one year

in your district. This research project has been approved by the Uganda  
National Council for Science and Technology and cleared by the Office  
of the President.

I am requesting you to give the researcher the necessary assistance to  
facilitate the accomplishment of the study. Your cooperation in this  
regard will be highly appreciated.

Yours faithfully,

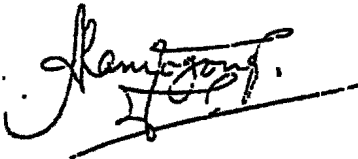

Jimmy Alani  
for: EXECUTIVE SECRETARY  
UGANDA NATIONAL COUNCIL FOR SCIENCE AND TECENOLGY

FORM RA.3

Research Act, Section 26A.

No 02130

RESEARCH ACT, 1986  
RESEARCH COUNCIL OF ZIMBABWE  
CERTIFICATE OF REGISTRATION

Name MR. HUDSON EDDIE KIBUUKA

Nationality: UGANDAN Passport No.: A019366

Institution of Affiliation in Zimbabwe: SOLUSI COLLEGE

Residential Address in Zimbabwe: GENERAL CONFERENCE ON SDA

EASTERN AFRICA DIVISION

P.O. BOX HG 100, HIGHLANDS, HARARE.

The bearer has been registered to conduct research in the field of EDUCATIONAL MANAGEMENT  
in terms of section 26A of the Research Act, 1986.

Expiry date: 31 SEPTEMBER 1997

Signature of Bearer

I. C. MAWINDI

Issuing Officer  
Research Council of Zimbabwe

Date: 26 NOVEMBER 1996

This receipt is not valid unless it is stamped

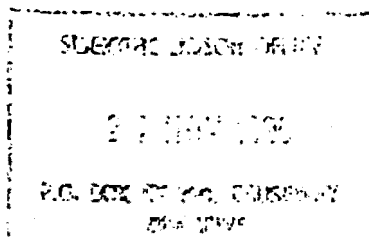



Fakulteit Opvoedkunde

UNISA

Faculty of Education

DEPARTMENT OF COMPARATIVE EDUCATION  
AND EDUCATIONAL MANAGEMENT

**TO WHOM IT MAY CONCERN**

This is to certify that Mr Hudson E Kibuuka (300-715-93) is a doctoral student of this Department. Any assistance given to him to aid him in his research will be appreciated.

PROF DC BADENHORST  
PROMOTER  
24/7/1996

Hudson E Kibuuka  
P.O. Box HG 100 Highlands  
Harare  
ZIMBABWE

The Vice Chancellor/Principal/Rector

---

---

---

---

January 6, 1997

Dear Sir,

I am doing a research on the Mission and Management of Religious Tertiary Institutions in Uganda, Kenya and Zimbabwe as part of my doctoral studies with the University of South Africa.

I have been informed that your institution is one considered in Kenya to be one such institutions that is developing well and I am interested in getting some information and data from you as part of this study.

I am therefore seeking an appointment with you to carry out a one hour interview in order to receive this information for this study which I believe will be useful to all of us who are interested in education in general and private religious tertiary education in particular.

Your assistance in this matter shall be highly appreciated.

Yours Sincerely,

Hudson E. Kibuuka.

**APPENDIX C1**

Hudson E. Kibuuka

---

---

---

---

June 10, 1997

---

---

---

---

Dear Sir/Madam,

I am doing a study with the University of South Africa on a recent development in many African nations, the establishment of private universities. I believe that this development is a welcome development which like many other new development s has its own challenges.

Your position in relation to your institution indicates that we share the same interest and because of that, I am requesting your cooperation in filling the enclosed questionnaire. It should take you no more than 20 minutes to complete in one sitting.

Your response will treated with the confidentiality it deserves in accordance with research ethics, and your participation is, of course voluntary.

Please answer all questions and return the completed questionnaire in the enclosed envelope as soon as possible.

Your participation in this matter will not only assist in the completion of the study but the results thereof will, I believe, go along way in assisting policy makers and planners of education to strategically plan for the much needed higher education.

Thanking you in advance for your assistance.

Yours Sincerely,

Hudson E Kibuuka  
Researcher

xc Vice Chancellor/Rector/Principal





- (i),(iii)
- (i),(iv)
- (ii),(iii)
- (ii),(iv)
- (iii),(iv)
- (i),(ii),(iii)
- (i),(ii),(iv)
- (ii),(iii),(iv)
- (i),(ii),(iii),(iv)

8. When was the current mission statement developed?

- over 10 years ago
- 5-10 years ago
- 0-5 years ago
- I don't know.

9. When was the mission statement last revised?

- over 10 years ago
- 5-10 years ago
- 0-5 years ago
- Has never been revised
- I don't know.

10. Who was involved in the development of the mission statement?

(i). Founding body, (ii). Institution governing board/council, (iii). Head of the institution, (iv). staff. (To be used for both questions 10 and 11).

- (i)
- (ii)
- (iii)
- (iv)
- (i),(ii)
- (i),(iii)

(i),(iv)

(i),(ii),(iii)

(i),(ii),(iv)

(i),(iii),(iv)

(ii),(iii),(iv)

(i),(ii),(iii),(iv)

Other, specify \_\_\_\_\_

11. In your opinion, who should be involved in developing/revising a mission statement?

(i)

(ii)

(iii)

(iv)

(i),(ii)

(i),(iii)

(I),(iv)

(i),(ii),(iii)

((i),(ii),(iv)

(i),(iii),(iv)

(ii),(iii),(iv)

(i),(ii),(iii),(iv)

Other, specify \_\_\_\_\_

12. Should a mission statement be revised?

Yes,

No,

13. If Yes, why should the mission statement be revised?

---



---



---



---

14. If no, why should a mission statement not be revised?

---

---

---

15. In your opinion how often should an institutional mission statement be revised?

Every 10 years,

Every 5 years,

Every two years,

Other, specify \_\_\_\_\_

16. How much does religious mission influence the mission of your institution?

Too much

Very much

Just right

Very little

Not at all

17. In your opinion, how much should religious mission influence the mission of a religious institution?

Fully

Some what

Not at all

18. How much do the institutional programs fall in line with the mission of the institution?

75 - 100%

50 - 75%

25 - 50%

0 - 25%

19. In your opinion how much should the institutional programs fall in line with the mission?

75 - 100%

50 - 75%

25 - 50%

0 - 25%

20. What role does your institutional mission play in the appointment of top executives of the institution in practice?

Critical

Very important

Important

Somewhat important

Not important

21. In your opinion, what role should the mission play in the appointment of top institution leaders of the institution?

Critical

Very important

Important

Somewhat important

Not important

22. Is your institution affiliated to any other institution?

Yes,

No

23. How does your institution mission statement relate to that of the affiliating institution?

The same

adapted

Somewhat different

Very different

24. Should finances be a determining factor of a mission statement?

Strongly agree

Agree

Disagree

Strongly disagree

Other, specify \_\_\_\_\_

25. Should the mission of the founding body be a factor in determining that of the institution?

Strongly agree

Agree

Disagree

Strongly disagree

Other, specify \_\_\_\_\_

26. What should, in your opinion, be role of the Government in the operation of your institution?

Controlling

Supportive

Partnership

Providing financial support

Non interference

27. Should your institution accept financial support from the government?

Yes,

No

Other, specify \_\_\_\_\_

28. How much control should come with such support?

Full control

Some control

No control

29. What percentage of the instructional staff, in your opinion, are committed to the mission of the institution?

0-25%

25-50%

50-75%

75-100%

30. Which of the following better defines your regular work?

- Church worker
- Government employee
- Private business person
- Employee of other educational institution
- Employee of a non - government organisation
- Other, specify \_\_\_\_\_

31. Which of the following best defines your profession

- Clergy
- Educator
- Manager
- Financial controller
- Other, specify \_\_\_\_\_

Answer each of the following questions with a 0 for "No", 1 for "To some degree", and 2 for "Yes"

(Adapted from Campbell and Yeung 1990: 24)

1 The purpose

- a. Does the statement describe an inspiring purpose that avoids playing to the selfish interests of the stakeholders?

0[  ] 1[  ] 2[  ]

- b. Does the statement describe the organisation's responsibility to its stakeholders?

0[  ] 1[  ] 2[  ]

2 Strategy

- a. Does the statement define a business domain, explaining why it is attractive?

0[  ] 1[  ] 2[  ]

- b. Does the statement describe the strategic positioning that the organization prefers in a way that helps to identify the sort of competitive advantage it will look for?

0[  ] 1[  ] 2[  ]

3 Values

- a. Does the statement identify values that link with the organisation's purpose and act as

beliefs that employees feel proud of?

0[ ] 1[ ] 2[ ]

- b. Do the values "resonate" with and reinforce the organisation's strategy?

0[ ] 1[ ] 2[ ]

4. Behaviour Standards

- a. Does the statement describe important behaviour standards that serve as beacons of the strategy and the values?

0[ ] 1[ ] 2[ ]

- b. Are the behaviour standards described in a way that enables individual employees to judge whether they have behaved correctly or not?

0[ ] 1[ ] 2[ ]

5. Character

- a. Does the statement give a portrait of the organization, capturing its culture?

0[ ] 1[ ] 2[ ]

- b. Is the statement easy to read?

0[ ] 1[ ] 2[ ]



**INTERVIEW SCHEDULE**

WHAT IS YOUR MISSION?

- WHEN WAS THE CURRENT MISSION STATEMENT DEVELOPED?
- WHO WAS INVOLVED IN ITS DEVELOPMENT?
- HOW OFTEN IS IT REVISED?
- WHEN WAS IT LAST REVISED?

WHAT MAKES YOU A CHRISTIAN/ RELIGIOUS INSTITUTION?

HOW IS THE MISSION TRANSLATED INTO PRACTICALITY?

- IN THE LIVES OF THE STUDENTS?
- IN THE LIVES OF THE LECTURERS?
- IN ADMINISTRATIVE PRACTICES?
- IN THE GENERAL LIFE OF THE INSTITUTION?

WHEN WAS YOUR INSTITUTION ESTABLISHED?

WHAT IS ITS HISTORY?

ARE YOU CHURCH MAINTAINED OR CHURCH OWNED?

- CHURCH RELATED?
- INDEPENDENT?
- MULTI-RELIGIOUS?

WHAT IS YOUR RELATIONSHIP WITH THE FOUNDING CHURCH?

WHAT IS YOUR RELATIONSHIP WITH THE GOVERNMENT?

WHAT IS YOUR UNDERSTANDING OF THE NATURE OF TRUTH?

HOW DO YOU DEAL WITH THE "ISMS" OF PREVALENT IN EDUCATION TODAY?

- HUMANISM, SECULARISM, ETC?

WHAT IS THE MANAGEMENT STRUCTURE OF YOUR INSTITUTION?

IS YOUR INSTITUTION REGISTERED, CHARTERED, RECOGNISED, ACCREDITED?  
BY WHO?

WHAT IS THE SOURCE OF YOUR FUNDING?

DO YOU RECEIVE ANY FUNDS FROM GOVERNMENT?

IF YES, UNDER WHAT CONDITIONS?

IS YOUR INSTITUTION AFFILIATED TO ANY OTHER INSTITUTION?

WHAT IS YOUR CURRENT ENROLMENT?

WHAT IS YOUR ESTABLISHMENT?

# Local private university students to get State aid

**Herald Correspondent  
MUTARE.**

THE Government would give loans and grants to local students studying at private universities in the country, beginning next year.

At present, the Government is only assisting those at the University of Zimbabwe, National University of Science and Technology and at some universities in South Africa.

Addressing students and staff at Africa University, a United Methodist Church-related institution at Old Mutare, the Minister of Higher Education, Cde Ignatious Chombo, said his ministry had already signed the papers related to assisting students at private universities. The papers were now with the Cabinet finance committee.

He said depending on

the ordnance papers submitted by the university authorities, the local students would get 25 per cent free grants while the loans will be 75 percent.

The minister could not be drawn to say how soon this would be implemented. However, in a brief interview with journalists, Cde Chombo said the money would be disbursed any month during the first half of next year "but want this to be done as quickly as possible".

There was no reason why local students at private universities should not get Government grants and loans while those studying outside the country were being helped.

A new system of disbursing the funds would be implemented where the students would withdraw the money from the banks, instead of getting

it from university authorities. This would help clear complaints where students say they had been given less than what they were entitled to.

The new method could involve the banks, university authorities and the parents.

Such detail would be used for future tracing of those helped by the Government when repaying the loans.

Cde Chombo said the repaid loans would be used as a revolving fund to help other students at the very university the student was attending.

He ruled out completely the possibility of the Government giving financial help to students who fail their examinations, saying the money would be used to assist those who want to begin studies.

THE HERALD AUGUST 19, 1996 Page 4

# Private university students to get grants

**BULAWAYO.** THE Government is finalising preparations for

## Medical lab scientists up for more pay

**Herald Reporter** MEDICAL laboratory scientists in private practice say they are not being adequately paid by the National Medical Aid Societies, yet they play a pivotal role in the diagnosis and prevention of diseases.

In a statement last week the Zimbabwe Institute of Medical Laboratory Scientists said it was concerned by the discrepancies that exist in remuneration between laboratories for the same quality of service provided at the same rate of expenditure in carrying out an analysis.

awarding loans and grants to local students at the country's two private universities.

A senior official in the Ministry of Higher Education said that the government had already approved in principle ordinances for the financial assistance starting this 1996/97 fiscal year.

But, he said, what remained was for the Minister of Finance, Cde Herbert Murerwa, to sign the ordinances before the grants and loans were released.

"It is a question of time before that happens... We have passed the stage of discussions," the official said.

Zimbabwe has only two private universities — the Seventh Day Adventist church-run Solusi University near Bulawayo and the United Methodist church-related Africa University in Mutare.

The official said Zi-

mbabwean students at Africa University and Solusi would receive grants and loans equal to those given to their counterparts at the state-owned University of Zimbabwe in Harare and the National University of Science and Technology in Bulawayo.

High Education Minister Dr Ignatius Chombo announced last year the government was considering extending its educational loan schemes to local students at the private universities.

Meanwhile, Solusi University said it had enrolled 240 new students in the faculties of business studies, arts and sciences this year.

Director for development and public relations, Mr Absalom Mhosva said the institution had increased its enrolment of new students from last year's 132. — Ziana.

## Appealing for funds

THE Indigenous Commercial Farmers' Union first vice-president, Mr Davidson Mugabe, yesterday said farmers in his province had lost 50

from having lost their cattle to the drought the indigenous farmers were generally under-stocked hence the need to increase their stock.

PHOTOCOPIED BY THE NATIONAL ARCHIVES OF ZIMBABWE

# Uganda Drafts a Bill to Govern Universities

■ **Education:** A bill presented before the Ugandan cabinet sets out for the first time minimum standards for setting up institutions of higher learning

by JAMES KIGOZI  
THE EAST AFRICAN

THE UGANDA Ministry of Education, alarmed by declining college standards, is preparing a bill intended to set uniform standards for the fast-growing number of private universities and other tertiary institutions of learning.

The Private Universities and Tertiary Institutions Bill, which has been tabled before the cabinet, will specifically address the academic programmes offered by the various institutions, examination schedules, qualifications for the teaching staff and management

of the institutions. The Bill looks at sources of funding, the levels of tuition charged and the background and objectives of their founders.

"Institutions of higher learning, especially private universities, have been cropping up everywhere in an unco-ordinated manner," an official in the Education Ministry Under Secretary's office in charge of Higher Education told *The East African*.

He said the Ministry was especially concerned by the low calibre of lecturers in some institutions: "A report submitted by a technical committee of the ministry showed that some of the lecturers in the private institutions did not even have a first degree, yet they are purporting to train students for degree courses."

The committee, commissioned to assess the status of various institutions of higher

learning that have been mushrooming all over the country, reported that "most of them occupy former primary or secondary schools which lack adequate room for expansion or accommodation facilities."

If the Bill becomes law, some "universities" will either have to improve on both their academic programmes and physical infrastructure or revert to the classification of training colleges, the official added.

An average of 20,000 students complete university-entry level education every year, but a mere 10 to 15 per cent of those who qualify gain admission to public universities — mainly Makerere University and Mbarara University of Science and Technology. A smaller number is admitted at the Islamic University at Mbale, eastern Uganda.

Entry requirements are two principal passes but in practice a student must score

three good principles, either A or B, to be assured of much sought-after government sponsorship at the public universities.

Private universities sprang up in the late 1980s to fill the void. The Islamic University in Uganda, sponsored by the Organisation of the Islamic Conference, was launched in 1987 and admits students from English speaking sub-Saharan Africa. Last week, President Yoweri Museveni laid the foundation stone in Kampala for a \$5 million office block sponsored by King Fahd of Saudi Arabia as an income-generating project for the university.

Others are the Catholic Church-funded Uganda Martyrs' University at Nkozi, the Anglican Christian University at Bishop Tucker Theological College in Mukono, the private Ndejje University in Luweero, the Seventh Day Adventist Bugema University. The proposed Busoga and Buganda universities could soon be established.

*Some of the lecturers did not even have a first degree*

# Nkumba varsity launched

By Pauline Mbabazi and Henry Bongyerirwe  
NKUMBA College of Commerce and Advanced Studies will offer university courses in business studies effective September this year, Board of Governor, Chairman, Mr Edward Kasolo Kimuli, said on Saturday during a graduation ceremony at Nkumba.

Nkumba becomes the seventh university in Uganda, following Makerere, Mbarara, Mbale, Ndejje, Nkozi and Bugema Seventh Day Adventist University.

Kimuli said Nkumba University will offer three-year degree courses in Business Administration, Business Education, Office Management and Secretarialship; Arts and Design, Hotel Management Catering and in Tourism.

The university was launched by the chairman of the Constituent Assembly (CA), Mr James Wapakhabulo, who also awarded diplomas and certificates to 299 students who had completed courses in various disciplines the previous academic year.

Wapakhabulo also launched a two-storied block hostel for women and toured the school projects.

Wapakhabulo hailed initiators of the college for building it from a kindergarten in 1952 to a university today.

He welcomed the institution calling it non-governmental and not based on religious affiliation.

## Okoth suspect netted

By Onyango Kakoba in Tororo

A MAN suspected to have been involved in the robbery at the home of the Archbishop of the Church of Uganda, Dr Yona Okoth, on Thursday appeared before a magistrate's court charged with robbery. He reappears on June 30.

John Owon, 26, a driver to the archbishop's wife Jessica was remanded by a Tororo Grade One Magistrate, Mr Praff...



Graduands of Nkumba College of Commerce and Advanced Studies moving to take their seats before and certificates on Saturday. Photo by Henry Bongyerirwe.

# Kumi kids eat lizards

Chris Osekeny Jamu in Kumi

THE RC5 Chairman, Kumi, Hajji Umar Okodel has confirmed that some people in the area have eaten lizards due to famine that has hit the area.

At a district meeting attended by the Prime Minister, Mr George Cosmas Agyebo recently on a fact finding mission in Kumi, Okodel reported that children under 18 years had hunted and roasted lizards.

The groups were stopped from eating more repiles by threats that the dish was

poisonous.

The explanation was prompted by Agyebo's inquiry about press reports on the gravity of the situation in famine stricken Teso.

"Is it true that the Iteso have gone to an extent of eating lizards here?" Agyebo asked the RC5 Chairman, Ongino, Mr E. Adome.

Agyebo was touring Akide village where the largest number of deaths had been reported.

"People have died and continue to die day in and day out" Adome said. "I do agree that the Iteso can eat bitter poisonous cassava we call *ogwang*" in our language, but I don't agree they can eat the lizards. Who can show me the lizards now, which type have been eaten?" Agyebo demanded.

Agyebo also demanded explanation about children who were abandoned.

The District Probation and Welfare Officer, Mr Stephen...

children had been abandoned. The 120 figure reported in the press, he added were on the streets feeding on garbage in and around markets and most of them sleeping on veranda in the town.

Crowds gathered in Akide with saucepans, basins and containers. Many ran towards

## Police arrive

By Kalyango Yusuf Junior

POLICE on Friday night rounded up 257 people in Kiganda, Muzaana, Kikajjo and Market view zones in Kampala while residents watched the World Cup match at 3:30 a.m.

Police knocked, banged and kicked doors and demanded identity cards and graduated tax tickets, a Muzaana zone resident said. The police PRO Mr Ngobi Robert told *The New Vision* on Saturday that the deployment was made from CPS Wandegaya, Old Kampala and Kawempe...

# Ruzindana holds 5th CA

# 10. Bugema University

Source: The Uganda Journal vol 42, Dec 1995 p 89-90.  
 (Jnl of the Uganda Society) Moses L. Golola.

Owned and operated by the Uganda Seventh-day-Adventist Church, Bugema University is located on a 420 acre tract of the church's land in Bamunika County, Luweero District. The campus is situated about 32 kilometres north of Kampala and about 16 kilometres from the Gayaza-Zirobwe road.

This institution originally started as a teacher training college in 1948. In 1953, the school was registered with the Uganda Education Department as a Senior Secondary School with the first secondary students sitting for their Cambridge Overseas School Certificate examinations in 1955. In 1970, a seminary at the level of Junior College was established at Bugema to train the clergy of the Church toward a 2-year Diploma in Theology. In the late 1970s this course was developed to a full degree programme in Theology.

In 1990, the Bugema School's board decided to expand this seminary into a full liberal arts college to offer academic and professional degrees besides the degree of Bachelor of Theology.

Accordingly, the Bugema Adventist Secondary School, which was previously on the same campus as the seminary was relocated on another part of the Church's property and the administrations of the two institutions became distinct. From September 1994, the seminary was christened Bugema University and offers the following degrees: Bachelor of Theology, Bachelor of Arts in Religion and Bachelor of Business Administration with majors in Accounting and Management.

The University was founded to provide high level education to potential employees of the Seventh-day Adventist Church and also members of the general public. In a country where less than 30% of qualified individuals are accepted annually in government universities there is a great need for the existence of alternative institutions where those who are unable to attend government institutions can try their luck. Fortunately the members of the SDA Church in Uganda and the public at large have shown a keen interest in the establishment of the University at Bugema and are willing to support it morally and materially.

Bugema University is the only Seventh-day Adventist institution of higher learning in Uganda. It endeavours to foster the holistic view of educating the whole being through the harmonious development of the physical, cultural, intellectual, mental and spiritual faculties.

The mission of the University inheres in the provision of a liberal, yet functional, curriculum programme in arts and sciences and in professional preparation in business, education and theology.

*ownership & philosophy*

*mission*

Throughout its programmes of instruction, research and public service, the University seeks to enlighten the mind, to enhance the quality of personality, to enable each individual out of Christian love and concern to serve mankind creatively, responsibly, and humanely and to enkindle a never-ending search for knowledge and truth.

Recognising the influence of a suitable environment upon learning and in order to ensure the achievement of the mission described above, the University seeks to provide a physical environment and appropriate academic and student support systems to facilitate the variety of human interaction and relationships essential for learning, and to provide programmes and facilities which allow for continuous evaluation, growth and expansion of the institution.

One of the problems that a young university like this has to face is the shortage of well-trained manpower committed to carry on duties in an institution of higher learning located in a rural setting. Fortunately, the SDA Church hierarchy has allocated six expatriate budgets to supplement our local manpower during the initial stages of the University. But the University needs to have its own staff-development programme. To date, there are four individuals overseas who are pursuing higher degrees on the staff development programme: these should join us shortly.

Housing of both the academic and support staff is another challenge. There are very few (if any) suitable houses that can be hired within the neighbourhood for the use of University personnel. This means that the institution has to invest colossal sums of money to provide suitable housing for its members of staff. In the last three years a number of houses have been constructed but many more are still needed.

Another problem is the perennial shortage of textbooks. Textbooks are very expensive and difficult to obtain. This notwithstanding, the University has succeeded in obtaining all the major textbooks which are loaned to students at a small fee. The idea of a book bank seems to be the only practicable one for us at this time.

The University has good prospects to succeed in attaining its goals. The existing staff is highly qualified and extremely committed to the mission of the institution. As already mentioned, the University has plenty of land. About 100 acres of this land has been earmarked for crop farming, and about 50 acres for a dairy farm with 25 cows. The produce from the crop farm and dairy will be used by the University students and staff. This will keep the costs of the University reasonably low.

It is planned that, subject mainly to availability of staff housing, additional arts and science courses including a course food technology will be added in 1996-97. It is projected that the student population, which now stands at 200, will have reached 400 by September 1997.

Construction of the main library is the next major project of the University and is slated to commence in January 1996.

# Open university plans at advanced stage

Herald Reporter

PLANS to establish the Zimbabwe Open University are at an advanced stage, the Deputy Minister of Higher Education, Dr Sikhanyiso Ndlovu, said in Singapore at the weekend.

In a keynote address at the Commonwealth of Learning Conference on Educational Technology 2000, Dr Ndlovu said the institution was intended to serve not only Zimbabwe but the region and the international community.

He said the Government was establishing the university to cater for the thousands of people who could not be absorbed by the formal universities and training institutions.

The major mission for the university would

be to provide people with greater opportunities of access through open and distance education. The ZOU would be dedicated to the fundamental principles of administrative autonomy and academic freedom which were central to free intellectual inquiry and the maintenance of excellence in teaching and research.

The ZOU committee, which Dr Ndlovu heads, has asked for a budget of \$90 million over the next four years and hopes to see 25 000 Zimbabweans learn through distance education within that period.

He appealed to delegates at the conference for assistance in human resource development

and support in efforts to secure the educational technologies necessary for operating the ZOU.

"I envisage more collaboration among open and distance education institutions, thus creating a global village where global certificates and degrees will be awarded by a consortium of universities and colleges without walls."

The deputy minister urged scientific inventors in industry to increase consultations with open and distance educationists to come up with new innovations which would promote open and distance learning.

"By year 2000 we should see more use of solar energy for powering open and distance

learning equipment. Mechanical winding springs to generate power as the recently invented winding radio in South Africa should be explored for us in rural areas," he said.

Last June, the Zimbabwe Government and Australia's University of Southern Queensland signed a co-operation agreement which, among other things, covered collaboration in areas like human resources development and procurement of multi-media equipment for the ZOU.

Senior staff from the University of Southern Queensland would collaborate with the ZOU in the specific study programmes.



# Historic varsity loan plan

By DAVID ADUDA

For the first time in the history of higher education in Kenya, students from private universities will get government loans this year.

Already, about 200 students from the only three chartered private institutions of higher learning — Baraton, Daystar and Catho-

lic University of Eastern Africa — have applied for loans.

"The board has accepted in principle to consider some of these students for the loans although the amounts have yet to be decided," the Secretary of Higher Education Loans Board, Prof Chacha Nyaigotti-Chacha, said yesterday.

The board would, however, meet soon to decide on the number to benefit and the amounts to be given.

"We must consider the money available and the levels of needs of the students," he said.

Prof Nyaigotti-Chacha, who was releasing the loans for the 1996/97 academic year, said about 30 per

cent of the students in public universities — about 12,600 out of a total of 42,000 — would not benefit.

"Our records indicate that out of the total population of 42,328 in public universities, 28.9 per cent

PAGE 2 — COL 6

## Historic loan plan for varsity

FROM PAGE 1

did not apply or qualify for the loan," he said.

Ninety-five per cent of the beneficiaries will receive between Sh20,000 and Sh42,000, to be disbursed in two equal installments.

From that payment, Sh4,000 per student will be remitted to the universities for tuition each semester.

The board will disburse about Sh880 million to the students during the 1996-96 academic year.

Last year, the board disbursed loans to 34,527 students.

In the meantime, loans for fourth year students of Maseno University College will be ready for collection at the local branches of the Kenya Commercial Banks from September 20.

First to third year students of Maseno and those from other universities will be notified in due course on the dates to collect their loans.

The board announced that it would consider appeals from students who did not qualify for loans.

Answering Press questions, the Secretary said the board was recovering about Sh10 million from past beneficiaries every month.

"We handle an average of 100 new cases of loans every day wishing to repay the money," he said.

The objective of the board is to recover all the money owed by past graduates so that it could establish a revolving fund in the next five years.

"This will enable us to give loans to students without going to the Treasury for funds," he said.

He said stern action, including legal proceedings, would be taken against loan applicants caught cheating about their backgrounds.

A recent Press report indicated that about 18,000 applicants, representing 60 per cent of the affected students, had cheated.



## Comment

# Let's get educational training system right

PRESIDENT Mugabe dwelt extensively on two major issues in his address opening the Second Session of the Fourth Parliament on Tuesday: the need for a national vision of where Zimbabwe wants to go over the next quarter century, and the need to increase the quality and usefulness of all education, ensuring that everyone could benefit.

The two are related. The type of education and training, informal and formal, offered our people will mould the future more than any other factor. To decide where our limited educational resources should go requires a good idea of the sort of society we want to create.

As the President noted, education might start at school but it certainly does not end there, especially in a world of rapid technological change and advances.

Everyone needs to be able to have access to the opportunities that continuing education brings, including the smallholder wanting to improve his farming and the rural businessman looking for a suitable area of endeavour.

Anyone can say they want a better life. Defining what this means in practical and realistic terms, looking at the resources likely to be available, is the meat of a major national debate and a continual process of refining ideas.

The President sensibly did not make wild promises about education, training and access to information. But he did stress the need that all, including the people and the children in the rural areas, should benefit with emphasis placed on the most disadvantaged whom, as he noted, tended to be women and rural people.

Better schools, more career guidance, more vocational training, a final push towards total literacy, and access to accurate and specific information on business and skilled work are needed by Zimbabwe.

Among his ideas were more what were described as cultural facilities in rural areas. This is perhaps one of the most important points made. Cultural facilities are not necessarily places where people can listen to music and watch plays.

Far more they are libraries, reading rooms, places where people can meet each other and exchange views and information. Anyone who has visited the Murewa Cultural Centre, the prototype, will have noted that the library and the reading room are very heavily used.

Should we be able to get such basic facilities into every major rural centre, and preferably every growth point, then most people would have access to the sort of information they so desperately need.

It might be possible to combine these centres with secondary schools where these are conveniently placed, killing several birds with one stone, or one cash grant.

The schoolchildren would have access to better facilities, and the local community would have a valuable source of expertise to back the written information and visiting experts.

As most fast-developing countries have shown, getting the educational and training system right is the most important plank in raising the quality of life. Zimbabwe must now redouble its already commendable efforts to ensure that it finds the basic educational resources, and uses these to best effect to realise the vision of our future that we are busy thinking about.

# Tanzania to Get a Private University

**Education:** Catholics and Protestants are combining to give Tanzania its first private university, a \$10m initiative with a main campus near Arusha

By JOSEPH MWAMUNYANGE  
SPECIAL CORRESPONDENT

THE CHRISTIAN Social Services Commission, a joint institution of the Catholic and Protestant Churches in Tanzania, is establishing the first private university in the country, to begin opening in stages next year.

Commission officials said the main campus will be at Monduli Juu, Arusha, and four colleges will be developed around the country from existing medical, agricultural, theological and teacher training institutions whose buildings, curricula and teaching staff will be enhanced.

The government opened the door

to private universities by passing amended education legislation last year. It provided that all institutions of higher learning will henceforth be governed under a new autonomous body, the Higher Education Accreditation Council, which is yet to be formed.

The Director of the Commission, Dr Anza Lema, told *The East African* in an interview that the new university is expected to cost more than \$10 million (Tsh6.39 billion). Funding will be by church organisations abroad, including the Lutheran World Federation, as well as by local churches.

Dr Lema said the main campus at Monduli would have two faculties, Veterinary and Forestry. Constituent colleges are planned as follows:

A college in Iringa will initially offer courses in Administration and Commerce and subsequently degree courses in engineering and law.

The Kilimanjaro Christian Medical Centre in Moshi, which currently

## PRIVATE UNIVERSITY

- First private university in Tanzania to start operating next year
- Institution to be run by the Christian Social Services
- All institutions of higher learning to be placed under Higher Education Accreditation Council

teaches 14 short and medium courses in health and medicine to diploma level, will be upgraded to offer degree courses in medicine, dentistry and pharmacy.

The Teachers' Training College at Uyole Mbeya, will be upgraded to a university college specialising in educational studies at degree level. "Some \$2 million (Tsh1.27 billion) have been set aside for this specific project," Dr Lema said.

At the Makumira Theological College in Arusha, post-graduate courses will be introduced in Philosophy and Sociology, besides courses in other disciplines. "The establishment of faculties and departments will be done in stages, and according to needs and

availability of resources," Dr Lema said.

The university will establish staff exchange programmes whereby lecturers will go for teaching and sabbaticals at universities abroad while their counterparts come to Tanzania to widen their experience.

Monduli Juu was proposed because of its accessibility and the fact it has enough water and other essential facilities.

With only three universities for its annual 8,000 high school leavers, Tanzania produces fewer university graduates than its regional neighbours. Dar-es-Salaam University, the Sokoine University of Agriculture and the Muhimbili College of Health Science can absorb only about half of the leavers.

Education sources said a number of parties had shown interest in establishing private universities in Tanzania. However Professor Costa Mahalu, Director of Higher Education, said, "None has gone as far as the CSSC has done."

Under the amended education legislation, three committees will be set up to deal with accreditation, grants and admissions and to formulate standards for higher education.



## Teachers' Boon

President Daniel arap Moi on Friday created a new post of Chief Principal, in which will be placed 98 senior principals who head large provincial and national schools and teachers colleges. He ordered the 3,000 headteachers promoted.

## Funds Plan Off

The Kanu National Executive Committee on Thursday postponed indefinitely the scheduled July 20 funds drive for the controversial Youth Fund "because the party branches need more time to collect funds." This is the third postponement. The Fund was mooted last December.

Monday 26 May 1996

# University education must incorporate character development

**W**HILE primary education's explicit purpose is to civilise a whole neighbourhood, secondary education sprang as a stepping stone to university whose educational development was intended to provide a kind of instruction and a research environment which was indispensable to society.

To some extent our present society has significantly become more complex and so are its needs.

In various contexts, modern society is said to be an industrial, democratic, technological, open, changing, scientific, secular, multi-faith, and pluralistic society.

One outstanding feature of what has become an undefinable society is corruption. It "is rife all over the world, in all sectors including business and politics, but that does not make it morally right" (The Herald, April 16 1996).

If universities arose to meet specific needs of its society, shouldn't our modern universities incorporate in their educational curricula courses that would promote moral values?

**U**nfortunately, today's system of higher education has also become increasingly secularised, in contrast to its early roots. A history of universities reveals that such form of higher learning was founded and supported by both religious and philanthropic groups who were keenly interested in promoting academics in a context of character development.

But that has become the thing of past. University students today are rarely exposed to, or engaged in the development



THE University of Zimbabwe's student representative council alone cannot manage and maintain all matters that concern students on a university campus. The administration has to take not only a lead but also an active part in attending to all areas of student life on campus. There are some people who are so resistant to change. But whether we are basically innovators or reactionaries, there is no possibility for growth in any area of life without change. There are some students who should not be considered for university because of their record of unruly behaviour, writes DR ONESIMUS NGUNDU, principal of Harare Theological College.

derstanding relates to their studies.

Allan Bloom is right when he says that the contemporary student is exposed to an environment of openness and indifference which leads to a type of mental vacuum when it comes to moral values and decision-making.

In other words, a proper starting point in formulating a strategy for the role and function of a university was and ought to be today a clear understanding of what a university is all about in relation to the needs of any given society.

**E**ssentially, a university is a body of scholars seeking and spreading truth as it provides general access to all areas of learning. Members of a university are its learned lecturers, able administrators good in inter-personal relationships, and well-behaved students who are united in a community of learning for the enlargement of mind which will benefit society as a whole. Moberly said a university should embody at least six basic principles:

- the conviction that things of the mind are worth pursuing
- the obligation to be meticulously accurate in dealing with empirical evidence

- insistence on freedom of thought and publicity
- the conviction that a university has indeed a social responsibility but that this is first and foremost a responsibility for focusing the community's intellectual conscience.

The foregoing summary brings out the moral dimension which should underline not only teaching but also the behaviour of students. A university, in the true sense of the word, should be a guardian of human values as well as an ambassador of international understanding.

Less formally, a university provides a context in which students can freely engage in a variety of social and other activities which can broaden their minds, and develop their personal relationships and give balance to their intellectual pursuits.

May I say, as someone who has spent a good chunk of his like and time in university corridors, to struck such a balance among university students coming from different backgrounds requires specific and firm measures to be enforced at all times. It is hard work.

Most students upon arriving at a university, begin to have "too much too soon". In business, the number one problem for

university campus. The administration has to take not only a lead but also an active part in attending to all areas of student life on campus.

People are motivated to learn when they see the value of what is being studied or practised from their individual perspectives. Most university students, though they would like to give us an impression of "no need of you adults", are young enough to be left alone in matters which require input and insight of experienced and mature people.

Lets face it. There are some people who are so resistant to change. But whether we are basically innovators or reactionaries, there is no possibility for growth in any area of life without change. To live is to change.

To be alive is to be adaptable. It is not a question of whether a university should emphasise knowledge for knowledge's sake. But whether its educational process is also aiming at behaviour changes and actions in society.

**T**here are some students who should not be considered for university because of their record of unruly behaviour. Not only will they continue to resist change and adaptability, but they will also tarnish

couraged in the development of an understanding of their unique position as children of God or how such an un-

350  
the obligation to approach controversial questions with the temper of a judge

nature or success is attitude. Nine out of 10 when a business goes bad it is because the people running it let success go to their heads.

the image and reputation of any university. University entrance requirements should not be limited only to aggregate points but behaviour must seriously be considered. A selection team and process should require all accepted students to sign necessary documents in the interest of the university. Parents or guardians of all prospective students should accompany their children to interviews.

They should be informed clearly and openly that the university authorities are not obliged to keep anyone who is a crusader of any form of misbehaviour. A university is a symbol of national pride, therefore, its reputation and image should be jealously guarded.

More and more it has become evident that financial handouts do not produce grateful hearts. Instead, recipients of Government grants tend to develop and exhibit the "you-owe-me more" attitude. Once people get to an institution where they know that everything is dependant on Government money, their human tendency is to abuse things. Therefore, individuals should pay for their university education.

It is interesting to note that once a child gets to university, parents seem to be less involved financially in their child's education. If Government can reduce tax deductions, most working people will manage to cater for their children's university education.

And only children of the really underprivileged people would then be seriously considered for scholarships or grants. No individual in his or her right mind would dig into his or her pocket to support an institution where indiscipline and vandalism are the order of the day. Any university would shut its financial supply valve when it accepts unruly students.

If education is attempting to find answers to questions, then one of the fundamental things university students need to know is how to live and how to live with others.

But how do students seek practical answers to these questions when they are inundated by various philosophies, approaches, and biases concerning the fundamental nature of man, our society, and the world? Modern universities generally promote a world view that is morally bankrupt. And we reap what we sow.

This is true of most university students, especially first years. Since the majority of the university student population are often the first persons in their families to attend university, they do not have family members in a position to provide the necessary insights and much-needed orientation and encouragement that is based on personal university experience.

Consequently, even the most well-meaning students are forced to either "do it alone" or "go with the flow of mob psychology". Usually, students of strong-willed personality take advantage of the passive and gullible masses and use them to the disruption of the normal life of a university.

Perhaps the most prevalent assumption is that the ability of individual students to succeed is directly related to their level of academic performance in the classroom. Yet, the lack of environmental and family support can mitigate against the role of the individual in succeeding in life.

If not the individual student, then who should play the crucial role in ensuring that first generation university students are academically and socially successful?

If students are to succeed academically, socially and morally, it is imperative that the interaction between them and their university faculty and staff members be positive, encouraging, and, in general, conducive to growth in these vital areas.

Lecturers other university staff should be role models in conduct to these aspiring scholars. Within the parameters of academic excellence, leadership behaviour and responsibility must also be encouraged and rewarded.

However, this is usually a difficult task in a society that has divorced itself from moral values. And yet it is the responsibility, both moral and intellectual, of university authorities to weave students into the essential and meaningful fabric of a university environment, if graduates are to benefit society academically and morally.

As I see it, the Student Representative Council alone cannot manage and maintain all matters that concern students on a

## DIPLOMA IN BUSINESS STUDIES

(I.C.M. (U.K.))

Commencing June '96  
ENROL NOW FOR AN EXECUTIVE CAREER

Part I  
Marketing, Accounting, Business Management and Administration, Economics for Business, Int. Business Communications.

Part II  
Business Law, Management Theory and Practice, Quantitative Methods for Managers, Business Environment and Ethics, Management Information Systems.

- \* Full professional Diploma or
- \* Single subject Diploma
- \* Most reasonable fees

ALSO

## DIPLOMA IN INTERNATIONAL BUSINESS STUDIES

(Institute of Commercial Management is a worldwide accredited body with centres in 87 countries. World organisations such as European Union work hand in hand with I.C.M.)

Phone  
**CRESCENT COLLEGE**

for more information,  
750425/773618/707146/729336

27338-CF31/85467-Y28

## British Study Centres ANNOUNCEMENT

These courses are now available to those who have passed COSC examinations:

**BUSINESS STUDIES** ● 3 year British University validated Master's Degree in Business Administration (MBA)  
● 3 year Chartered Institute of Management Accountants (CIMA) ● 3 year Chartered Institute of Bankers (AIB)  
● 1 year Association of Business Executives Diploma

**COMPUTER SCIENCE** ● 3 year MSc in Computer Science with final year at a top British University ● 2 year Association of Computer Professionals Advanced Diploma  
● 1 year combined ACP Certificate in Computer Programming & Diploma in Computer System Design

**HOTEL & TRAVEL MANAGEMENT** ● 2 year CTHCM Advanced Diploma in Hotel Management ● 1 year Diploma in Tourism & Hotel Management ● 1 year Diploma in Travel Agency Management (including British Airways Ticketing) ● 2 year Advanced Diploma in Tour Operation.

Grade requirements: dependant on course chosen  
Courses start: January, June & September  
Tuition fees: from £2,950 per year (Living costs not included since many students have family in the UK to stay with)

WEST LONDON COLLEGE **WLC** 

Dept 714 Avon House, 360-366 Oxford Street  
London WIN OLD England Fax: (+44) 171-499 5853

A division of British Study Centres Ltd, a non profit making company - Accredited as efficient by the British Accreditation Council for Further & Higher Education

NTE  
ame De  
24 Hou  
th Warrar  
ustomer E

THRC

2x 2120 - Harare  
P.O. Box 2249 - B

Sunday Mail  
MAY 10  
17-5-97

# Varsities must realise that most people are hounded by poverty

**A** CONCEPTUAL framework of university education coupled with an outline of historical developments in Zimbabwe will help lend weight on the topical issue of student loans or "education credit".

It is important to note that the majority of African universities were founded in the 1960s and were designed to be instruments for the realisation of independence and the solution of the problems of poverty, ignorance and disease. But primarily, their first major function was the training of personnel to succeed the departing colonial administrators.

The main thing individuals expect the university to do is to provide them with a rigorous intellectual training. From the outset, universities are public institutions dependent on public resources and inevitably directly accountable to the public. People who have themselves been to university, have more complex and sometimes more contradictory attitudes. They identify with the university's objectives, accepting its shortcomings and difficulties, but also tend to reject any changes which may have occurred "since their time". In what may be an instinctive defence of their privileges, they often show a marked resistance to the generalisation of access to university education and qualifications; together with the concern for the maintenance of high academic standards, a concern which can only reflect well on them since such standards are presumed to have existed when they were students.

They are therefore usually critical of the way universities operate, more concerned to preserve a number of traditional features. Criticism occasionally quite sharp does not mean that the university has lost its



University education is a necessity in every country, especially in African states where there are still few university graduates. However, it was not smooth-sailing for those who have gone through university education. Many intelligent young people from poor families have found it difficult to attain university education because of lack of school fees. Some have been lucky to get scholarships, while others were not so lucky and the struggle for fees is an on-going one every year. Financial constraints are one of the main problems facing students and many African universities today, writes **JAMES STEPHEN DHLWAYO** of Rusape.

prestige or renown. Even when degrees prove valueless for employment purposes, access to the university is still regarded as a step upwards.

Universities in Africa were credited with almost magic qualities and near-miraculous powers for providing quick solutions to the many problems of independence. The importance of their relevance and responsiveness to the needs of their societies, through their teaching, research and community or extension service, are all now largely appreciated. It is at the same time important to point out that financial constraints are now one of the greatest single factors facing African universities in the fulfilment of their responsibilities. Actually, the matter of finance stems from the increasing scarcity of resources as universities seek to grapple with national development.

**T**he university as a public institution should realise that a large percentage of the populace is beset by poverty, inequitable distribution of income, unemployment, underdeveloped agriculture and uneven development; to name but a few.

Thus the university should give itself the mandate of finding solutions to national problems as well as adopt a stance which will make it responsive to necessary and meaningful change within the society. The University of Rhodesia, for instance, was relevant for the kind of society that it had served. End-

less controversy arises with regard to the real or alleged purposes of the university; pressures representing disparate points of view are exerted as society changes its character or its motives or its criteria of achievement and success.

There has never been agreement as to whether the university should be for the few or the many. The basic intellectual function of the university has always been in a precarious state, and in modern times the precariousness is even more pronounced.

To speak of the intellectual role, therefore, is to speak of an aspect of the university that is forced to resist or adapt to pressures from many quarters if it is to retain its pre-eminence in academic life. There is for example, the pressure of mass education. No other less developed country in Africa, (this is open to correction) has so thoroughly embraced the concept of mass education or made such strong efforts to have it permeate the consciousness and the conscience of its citizenry within a short period, than Zimbabwe.

Actually, whoever believes in Zimbabwe believes that all its people must be educated as evidenced by the number of universities in the making or on the drawing board. The university cannot stand aside from the major issues facing society, not only because all these issues have intellectual roots which need to be uncovered for all to recognise, but also because it has within it much to offer for the pragmatic resolutions of such issues.

for university entry from taking up their places. The most serious of these was the lack of adequate financial assistance. Some grants were made available from the University for the aid of the poor students. The distribution of the grants was the responsibility of the university, however, racial bias in the awarding of the grants quite evidently favoured white students. Lonely M. (1975) contends that had it not been for the assistance provided by the World University Service and the Christian Council, which supported needy African students, not more than 200 African students could have been at the University.

**A**n evaluation of educational credit shows that student loans have been successful in increasing enrolments in many countries and have enable poor students to enrol who would not otherwise have afforded higher education. A point to note is that student loan schemes are not self-financing; therefore student loan programmes will continue to need regular injections of capital from government and other sources, for example the private sector. Actually one has to note that it is the spread of the notion of education as investment in human capital and the belief that education contributes to economic growth that encourage the idea that students should have greater access to capital markets in order to help them finance this investment.

In many countries, student loans were advocated as an ideal way of ensuring that individuals of high potential have access to

every reason to be grateful to Tony Blair whose vision, courage and obvious skills helped propel the party into office.

Prime Minister. He will combine this with a transport and environment portfolio. Gordon Brown becomes chancellor of the

And for the first time there will be sisters and twins (Angela and Maria Eagle) to sit as members of the Commons.

John Major had conceded defeat at his Huntingdon count saying: "Politics is a rough

recent British history. Triumphant Tony Blair said: "A new dawn has broken and it's wonderful. This is a new

# People are hounded by poverty

ers who help to subsidise them.

Be that as it may, and when the university performs its task properly and effectively, a person emerges who can find himself/herself a stable economic life technically or professionally; who can weave richer and deeper patterns of living through his cultural awareness and appreciation; who can assume a position of activity and even leadership in the expansion of knowledge and the pursuit of truth; who is constantly aware of the swiftness of change in modern civilisation

and receptive to such change; who can be moved to understand and desire world peace; who understands the responsibilities of freedom together with its rights and insists upon these responsibilities and rights for others as well as for himself/herself, and who is motivated to help solve the major social problems of his age.

In its intellectual role, the university couples intellect with character. It joins thinking with doing, and it places the educated man squarely in the centre of his society and keeps him there.

Whether loans increase the educational opportunities of poor students, or whether loans redistribute the costs of higher education, to bring about a more equitable distribution of costs and benefits. This apparently is an area where advocates of loans make the most optimistic claims, since it is well known that there are enormous inequalities of access in less developed countries and that existing methods of finance favour the rich, who benefit most from higher education, at the expense of lower income taxpayers.

mately the taxpayer, than a system of grants. A grace period after graduation; which allows a student to find a job before embarking on repaying the loan, should be provided. Part of students' debt may be forgiven or written off in certain circumstances, for example, if a student achieves good academic results, or works in priority or economically depressed areas; student loans can be provided interest-free.

The question of the effect of students loans on equality of opportunity and on equity raises two issues:

aid for students which enables a repayment obligation, on the part of the student, which may take different forms. In most cases the debt must be repaid, either with or without interest. In a given period of time, and the loans therefore resemble a mortgage. The fundamental difference between loans and grants is that students must repay the loan, and so contribute directly to the cost of their education, out of their subsequent earnings.

Thus, a loan involves less financial burden for the government; and ultimately

From Page 8

facilities, and for dealing with defaulters.

Experience has shown that administrative problems have often been underestimated, but they can be solved. The main purpose of student loans or educational credits is to provide access for students to capital funds, to enable them to finance all, or part of, the costs of their education, by borrowing, while they are studying, and to repay this at a later date. The terms "student loan" or "education credit" refer to a system of financial

352

The university has to be sensitive to the growth in student numbers intending to pursue higher education. The quantitative aspect of expansion should also instill some confidence that that expansion would automatically bring about a certain democratisation of our university system. The outstanding example of such optimism is that of transition to "a higher education for the masses" and to an age of "universal higher education".

The growth in numbers of potential university students is a reverse of the colonial times when the number of Africans eligible for university education was effectively reduced and this correspondingly increased the chances of whites getting a university education without significant competition from Africans (blacks). This is because the whites had more access to good schools and general educational opportunity, therefore student enrolment was accordingly white-dominated until the trend was changed in 1976 (Zvobgo 1992). Africans were seriously under-provided for.

The then Government's policy in education created a bottleneck system which seriously disadvantaged Africans and its effect was to eliminate the majority of African children from the education system.

It must be realised that white policies of racialism determined the development and provision of higher education to whites and blacks. The University of Rhodesian and Nyasaland came into existence in 1957 under an all-white College Council. The total enrolment of full-time students from the three territories in 1960 was 168 and only 30 were African students (Hanna A. J., 1960). This was so because the RF Government viewed educated Africans as a serious threat to whites in the professional services.

Again a number of difficulties, however, prevented a very large number of those who qualified

student loans were advocated as an ideal way of ensuring that individuals of high quality but of limited financial means should not be denied the educational opportunities that would lead to higher levels of personal and national income.

Introducing student loans is thought to encourage efficiency, improve motivation of students and allow government to assist a larger number of students. Many economists have argued for the greater use of student loans as a means of reducing the financial burden of government subsidies for higher education at a time of increasing financial constraints, for example, the austere Economic Structural Adjustment Programme.

Other economists have argued that student loans are more equitable than grants, since those who receive higher education will benefit by means of improved job opportunities and higher life time incomes, and should contribute to the costs of their education, out of higher earnings.

We should not blind ourselves from the fact that there difficulties of financing rising levels of educational expenditure, so this has led to the focus on student loans as a cost recovery mechanism which would allow governments to expand enrolments without imposing impossible burden on public funds.

It is true that if educational systems continue to grow at the present rate and under the same structural and managerial conditions, they will require funds that will be beyond the financial capabilities of many less developed countries, Zimbabwe included.

When introducing loans the government should pay attention to such questions as:

- i) the extent of the subsidy. The lower the rate of interest charged on loans, and the longer the repayment period, the greater will be the cost of subsidising loans,
- ii) the determination of repayment terms. It is important to establish efficient procedures for graduates in financial dif-

● To Page 10

# Bugema new varsity

By Michael Sentongo  
in Bugema

Source: NEW VISION (Kampala) Saturday, March 19, 1994

THE Seventh Day Adventist (SDA) propertied Bugema College is to become a fully fledged University with effect from September this year, the school authorities told President Yoweri Museveni yesterday.

Meanwhile President Museveni said, that his government welcomes anybody wishing to establish a university or any other institution of higher learning in Uganda. He said government has liberalised its

policy on education and will only be ensuring that acceptable standards are adhered to in operating private schools.

Welcoming the President at Bugema College where he laid a foundation stone for a 1,300 square metre multi purpose complex for the college, its authorities including Vice President Samson Kisekka said

that plans for making the school a university complex had been finalised.

They said that it is slated to open for students in September this year.

The chairman of the school's board who is equivalent to the title of Bishop in the SDA church, Pastor Stanley Kyambadde told the President

that up to now the college has been offering Theology degrees only.

He said, the board decided three years ago that it become university with both Arts and Science disciplines.

"We now want to add other faculties. We have already set

up a technical committee to work out the final modalities with the Ministry of Education", he said.

Kyambadde said the development of the university has necessitated the separation of the school's compounds of primary, secondary and now the university.

He disclosed that some of the staff to teach and work in the university have already reported.

President Museveni welcomed the new university saying that government's liberalised policy on education had continued to bear fruits in the opening up of private institutions of higher learning.

Museveni had earlier commissioned a new 100m/- science laboratory block.

He attacked Ugandan teachers who he said are a twist government trying to force it to pay them salaries which they know are not affordable. He said such teachers have long lost the noble virtue of having

conviction in what they are doing and think that money is the only thing they should get from the teaching profession.

"The money given to these teachers by the Ministry of Education is not very little as they claim. But it is just because these teachers lack conviction in what they are doing. They ask for money which the country does not have. They are talking like people who have just parachuted from heaven to Uganda", he said.

Museveni did not name teachers of any specific institution.

He commended the headmaster of the College, Mr Sebiranda and his staff for teaching the students practical trades like wood working, poultry rearing and crop production which gives the school 70% of the food requirements.

Museveni criticized Ugandans who overemphasise money saying when it is not readily available nothing can progress.

21-03-94



SOURCE: THE NEW VISION, SATURDAY - JANUARY 21, 1995

## Kintu

## Musoke

From page 1.

Ankole kingdom.

Although the Premier denies supporting the amendment, a copy of the said amendment obtained by the press from committee four and stamped by the clerk to the CA indicates Edward Ssekandi (Bukoto Central) and Kintu Musoke as the authors.

Most CADs had received the copies from their pigeon holes Mr Ssekandi's name is typed while that of Kintu Musoke is handwritten.

The CA rules of procedure allows more than one delegate to jointly sponsor and move an amendment.

Clerks at the CA yesterday insisted that they received instructions to include Kintu Musoke's name to the amendment.

In the release, Kintu Musoke argued that he was already satisfied with an earlier amendment he moved and was accepted which "restored Buganda on the map of Uganda".

## Museveni

From page 1

maintain calm at Makerere University campus.

However, the President disclosed that government's policy to be implemented in the near future was that parents and students would gradually take the responsibility of meeting non-instructional costs, at the University and other high level educational institutions.

He said government would retain the costs for instruction but in the near future, parents would meet such costs like accommodation. Mr Museveni reminded the students at Makerere University that they were not at campus to eat and sleep. He said the University programmes should be tailored to high level knowledge and not sleeping and eating.

He welcomed privately run universities saying this was a development in the right direction.

Earlier, the University Vice Chancellor, Prof. John Sebuwufu complained of the lack of academic staff. He requested government to attract teaching staff by considering increasing their pay.

# Twenty-two Bugema students graduate

By Charles Ariko  
 TWENTY-TWO students on Sunday graduated at Bugema University, seven of them with Bachelor of Business Administration degrees, the first to be offered by the university.

The Vice Chancellor, Prof Moses Golola, said that the NRM government had created an atmosphere which has enabled private institutions of higher learning to emerge.

The government has not only permitted their existence but has also promised to assist them professionally and materially, he said.

The university was going to be expanded, adding that the Council recently authorised the construction of a three-storeyed library media centre estimated to cost US\$700,000 with a sitting capacity of 450 students, Golola said.

He thanked Robert Folberg, President of Gen-



*Wapakhabulo: Donated \$200*

eral Conference of Seventh Day Adventist for the donation.

The Minister without portfolio, James Wapakhabulo who was the guest of honour, assured Golola of Government's commitment to support privately owned institutions.

In appreciation of the development at the university, he donated US \$200.

The University based on the American system of education offers Bachelor of Theology, Bachelor of Arts and recently Bachelor of Business Administration and a Diploma in Education. It became a University in 1994 and this is the second batch of students to graduate. The pioneers graduated in Theology.

tion, Monday, November 13, 1995

# Religious varsities to get grants

By Hillary Nsambu

PRESIDENT Yoweri Museveni has said government will provide a fixed annual grant to the four universities started on religious basis, starting in the 1996/97 budget.

The President, who was the chief guest at the closing of the Uganda Martyrs University week at Lubaga Cathedral yesterday, however, did not mention how much money would be provided. He added that he would be able to convince the Minister of Education for this just cause.

Museveni said he liked religion-based universities, because they impart morals which young Ugandans lack.

The four are Uganda Martyrs University, Nkok, the Islamic University in Uganda (IUI) Mbale, the Christian University of East Africa, Nakaseke, and the Seventh Day University in Bugema.

Museveni said the universities deserved the grants because they were carrying out a national duty.

"I am personally supporting the private universities because the children they are training are children of the nation whom everyone should be proud of," he asserted.

EDUCATION

# New university springs up

By Crespo Sebunya

TUCKED away in the gentle rolling hills 34 km (21 miles) north of Kampala is the upcoming Bugema University which is not only a static in the growing Ugandan universities but something unique to offer those yearning for university education.

In September this year, the private university will open its doors to those eligible to enter the university. It will initially offer four courses, namely Bachelor of Arts with a Diploma in Education, Bachelor in Business Administration, Bachelor in Religious Studies and Theology.

Just as we drove through its neatly lined boulevards to its campus of sober red-brick buildings, Vice-Chancellor Prof Moses Golora said if their dream came true in September, then it will be possible for one to enter primary at Bugema and then through to the university without leaving the place.

But perhaps more important, Prof Golora, a stern-faced, clinical Makerere-trained educator and historian, pointed out the need to orientate people's thinking that university education should not be seen just like manna from heaven.

"People have got to throw off this colonial mentality that

back to square one, rather continue from where they stopped, like the American system.

Dr Golora was until recently lecturing at Barotia University in Kenya. His experience there taught him to work against many odds, only focusing to see (to it) that his job comes out well done.

He was the only Black among the many European and American lecturers at this Kenyan university. This when he moved to Bugema in 1991, he drew inspiration from his earlier experience.

In just a space of three years, there is a complete change, a new secondary school has been built. This, together with the primary school have costed Shs 700m in the restructuring exercise.

Now the university, with all facilities and necessary infrastructure is already in place. Dr Golora has seized a chance at the right moment when the country sees more of university eligible students locked out of the system because of inadequate vacancies at public universities.

"In a country where less than 30 percent of students who qualify to enter the university are admitted, there is an obvious need for a privately funded institution to establish an alternative university to the Middle East University in Beirut Lebanon.



President Yoweri Museveni (in safari suit) with Bugema University Vice-Chancellor, Dr. Moses Golora on the occasion the President opened the buildings. Directly behind the President is Vice President Dr. Sanson Kisekka.

orders out of the country. The church also fell into another crisis when it was bundled with the other 27 sects and banned.

The General Conference saw that there was zero hope of having a university in Uganda. So they reached to Nairobi. So when the idea of

each book meant for the university costs an average of \$50. Through the university has 8,000 titles already, a population of 300 students would have 25 books per student, which according to some quarters is far from adequate. Nevertheless some external donors have provided Shs

seriously, the General Conference gave a helping hand by agreeing to pay the expatriate lecturers.

In the wake of restricted government spending which seriously curtails the development of public universities already, there is a feeling especially among donors, that

be free. We are leaving behind lines and so there is need to demonstrate our ability to stand on our feet," he said.

The university is charging Shs 300,000/- per term. It offers employment for those who may fail to raise the fees from their parents. It has already established a dairy farm, a poultry farm, a carpentry workshop and vast farms on its 420-acre piece of land. "Word is passing around that those students who may suffer long interruptions in their studies and stay for a long period of time may not go

in a situation where, though there is a will in government circles to establish public universities to cater for the growing number of eligible students, but external donors are discouraging the idea right now.

Dr Golora has seized a chance that may have eluded his predecessors. Bugema university would have been established by now. The General Conference, a supreme organ for the Seventh-Day Adventist Church headquartered in Washington had in mid-70s wanted to

for the alternative university. But unfolding events in the country proved that it was a wrong bet.

First, Idi Amin had developed a streak against the SDA Church and among the reasons was that the leader of the church in Uganda was referred to as a president. Amin found it unpalatable to have another president in Uganda beside him.

To make matters worse, he was an American. This automatically at that time meant that you were a CIA. This was enough to get you marching

Uganda was divided again, initially it was old, soldered by the SDA up the body. But being duty-bound to have university education, Administrators here for the time being went about the work without the General Conference.

Obviously without them, the task of establishing this university to be able to provide qualitative education will be like climbing up a mountain.

For instance, provision of needs like books is a problem. According to Dr Golora,

books.

Attraction of skilled lecturers can also be an agonising problem. To date 15 lecturers have been booked at the university, five of these are on doctorate level, while seven of them hold masters degrees.

Provision of an attractive package and other amenities to make them stick to their jobs is another university pre-occupation. The university to date has 20 three-bedroomed hungalows and is contributing seven others.

The place is served with two water pumps and one bore hole. All of these are capable of providing adequate water for the 2,000 people. When they saw that Ugandans were intent to establish a university

come and fill the vacant spaces left by the public universities. According to a report compiled in 1991 the Association of African Universities reported severe economic crisis which is seriously affecting the continent's educational systems.

"Specifically government grants to universities in Africa have come under increasing pressure as levels of funding could not match the requirements for critical inputs to sustain acceptable standards of instruction, research and service," concludes the report.

However, the success of private universities will also much depend on the trust local populations put

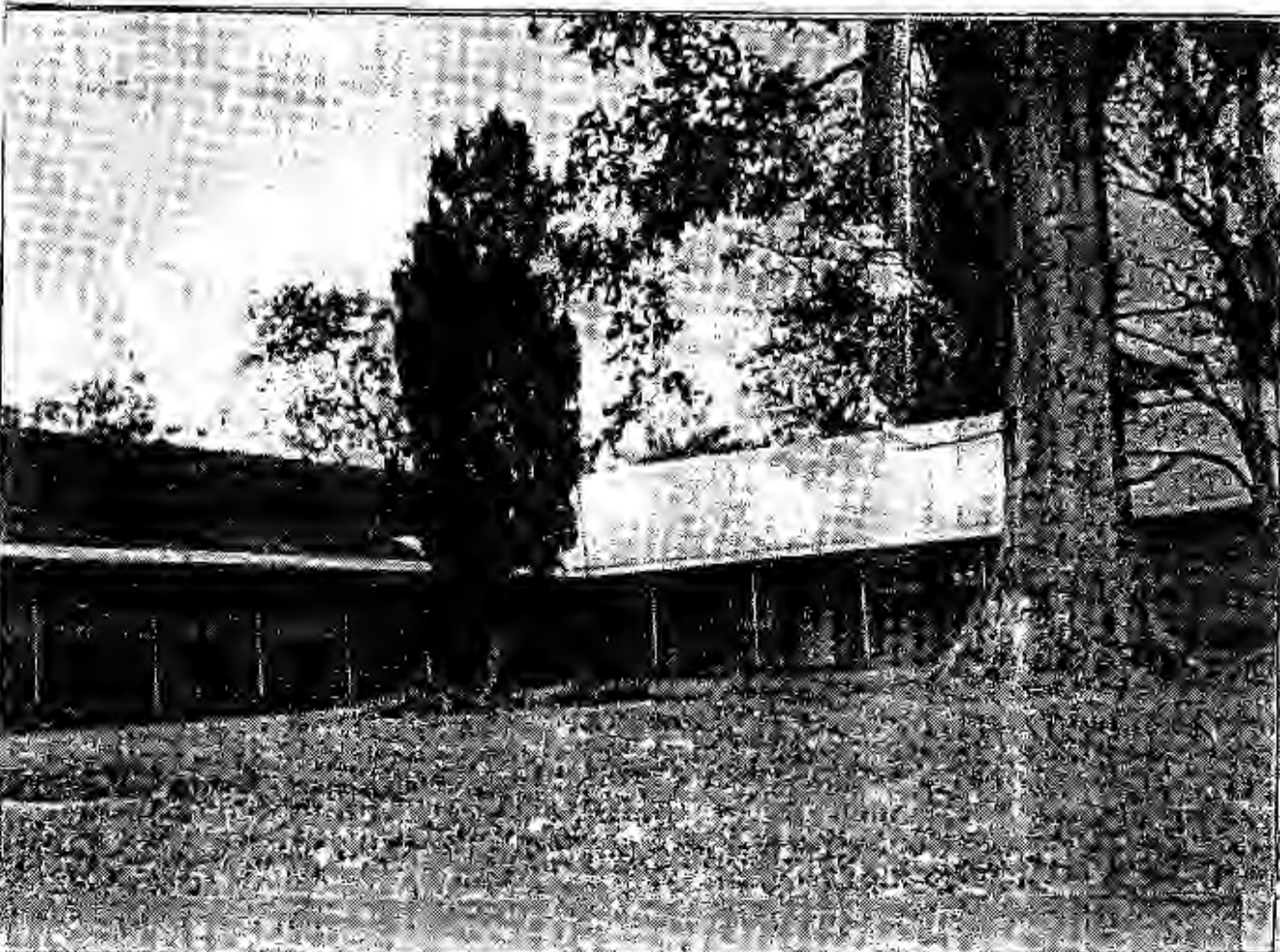

A rear view of the administration building of Bugema University.

## Do you want a penpal? Read this

TODAY'S world is filled with misunderstanding and fighting. People everywhere are exploring ways to build world peace.

Experts worldwide agree that true peace and understanding must begin with our youth. Letter writing to build better understanding between youth of the world... is something all children can do.

To make this possible, Student Letter Exchange, located in the USA, is offering to give up to four FREE PEN PALS to any student between 9 and 16 years of age, who can correspond in English.

Students Letter will match pen pal to students who request the free pen pals, and the pen pal will write the first

letter to the applicant.

Students will receive free pen pals from United States, as well becoming eligible to receive additional free pen pals from other countries like Britain, Italy, Korea and Japan.

It's easy and fun to participate. It's great for both boys and girls, and nine-year-olds can participate as well as 10, 11, 12, 13, 14, 15, and 16-year old students.

To receive FREE PEN PALS, send a letter written in English, and include your complete name, your complete mailing address (including the name of your country), your age and your sex. Send this information to: Student Letter Exchange, 215 5th Avenue South, East, Waseca, MN, 56097 USA.

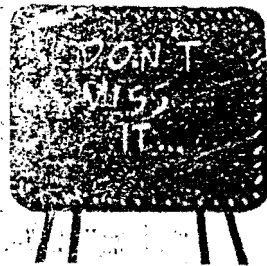

# BLACKBOARD

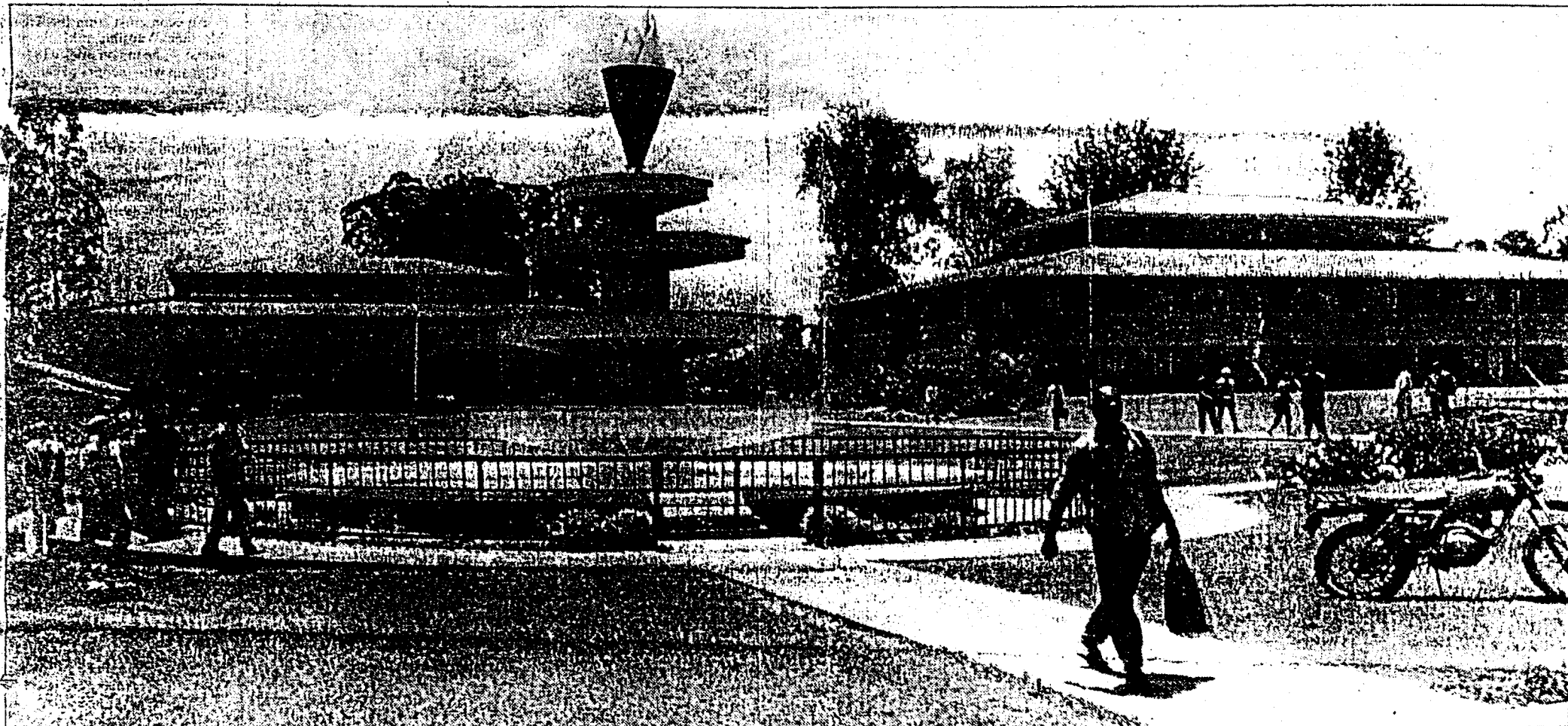

The Seventh Day Adventists University of Eastern Africa at Barot, Nandi District. It was the first private university to be accredited by the Government and its students will benefit from Higher Education Loans Board this year. (File Picture).

The decision by the Higher Education Loans Board (HELB) to advance students in private universities credit to meet their fees is a step in the right direction.

The Secretary to the Board, Prof. Chacha-Nyigoti-Chacha, says so far they have not decided the amount the students in private universities will get. But the important thing is that they will get something.

A precedent has now been set and we expect the number of students in private universities who benefit from the scheme will increase in future.

We are hoping that in the next round, students in national polytechnics and other reputable tertiary institutions will benefit from the scheme.

Some critics might argue that students enrolled in private universities were rich enough to pay their way and do not deserve the financial support.

While it is true that some students can afford to pay, many others come from middle-class families who were struggling to survive.

This class is renowned for the high value it attaches to education and would do anything to educate the children.

Some of the parents have borrowed heavily from co-operative societies and banks to raise the required money to enrol their children in these universities. Many others have sold their property to raise the fees.

Families had to organise harambee to raise fees for their children in the private universities while many students raised the money by doing odd jobs.

## Why private varsities students merit loans

So it was a myth to argue that only the rich enroll in the private universities.

The other advantage of assisting students in private universities was that it will promote gender equity in higher education.

The loans that will go to these colleges will benefit women who comprise about half of the 5,000 students enrolled.

Currently, only 25 per cent of the 40,000 students enrolled in State universities were women.

Parents were more interested in sending their daughters to private universities rather than to far-flung overseas institutions.

The private universities were better suited for women because of their high degree of discipline and better management of their academic programmes.

Most of them were run on Christian principles and had hostels where upcountry students can board.

In State universities, the few women were often sexually harassed by male students and staff.

The other advantage of extending the loan to private university students is that it will ease pressure on State universities which admitted only 8,000 of the 140,000 candidates who did Kenya Certificate of Secondary Education (KCSE) last year.

This means there were many candidates who had a grade B- who cannot enter State universities. But few of them can afford fees charged at private universities which were in the range of Sh200,000 annually.

However, if such students acquired HELB loans, they could enroll in the private universities.

There was also a large group of students who have been offered a place in the State universities but were reluctant to enroll there. This



By  
**WAMAÏU MUYA**  
Education Editor

is because of the incongruous semester dates, poor management of academic programmes and general indiscipline in these institutions, which make it impossible for a student to graduate within the prescribed period.

Form Four leavers almost take two years to join the State universities after doing KCSE. They waste more time at the campus due to unplanned closures.

Consequently, a four-year course often takes six years to complete.

To avoid such waste of time, many students would rather join a private university where they were assured of getting a degree within four years unless they flunked in

their exams. The private universities also offer undergraduate courses which were not available in State universities like psychology, communication, community development and others.

They have more openings in popular courses like business administration, nursing, information technology and others as compared to State universities.

The above shows that private universities have come of age and the Government should seriously consider sponsoring some students in these institutions.

Every Kenyan student who qualifies to enter a State university is assured of a bursary to cover most of the tuition expenses which were on average Sh70,000 annually.

In order to encourage qualified students to join private universities, the State could adopt a policy whereby any student who meets the cut-off point would be free to enter either private or State universities of their choice but be guaranteed of the bursary.

More students would afford to pay for private university education

if the fees were subsidised that way. It would reduce the overcrowding in State universities which has been eroding the quality of tuition. The private universities would also be getting some of the best KCSE candidates.

However, for all these measures to succeed, HELB will need more funding. Currently, it gets Sh800 million from the State which was hardly enough to service all the needy students.

HELB is expected to create a revolving fund and Education Minister Joseph Kamotho, told a donors consultative meeting last month that it required Sh2.3 billion if it was to give a Sh50,000 loan to all the 46,000 students enrolled in State and private universities.

The Government's position was to minimise funding on higher education and concentrate on basic and secondary education. But before it completely disengages, it should create institutions that help students to pay their way instead of abandoning them to their own fate.

Negotiations for higher education loan would be one solution to the problem.

Major donors like the World Bank have expressed readiness to fund a private universities loan scheme as long as the Government was ready to negotiate for it.

But the Board could be self-sustaining if it recovered the Sh2 billion owed to the State by former university students who have yet to repay their loans.

Some of the graduates now have children of university entry age and it was only fair they pay up so the young generation can also go through higher education.