

# The Reappearing Computer: the past and future of computing in design research

Simone Gristwood, Middlesex University, UK

Stephen Boyd Davis, Royal College of Art, UK

## Abstract

This paper investigates the early history of computing in design and in design research, focusing on individuals who were associated with the Department of Design Research at the Royal College of Art between the 1960s and the 1980s. The authors suggest that the theory and practice developed at that time may be valuable in thinking about the future, particularly when considering how computing may be used, in various forms, by designers in their work. A taxonomy of some early ideas and activities is presented which, it is suggested, displays a different emphasis from the way computing in design is conceived now. It is argued that as computing has become absorbed into mainstream culture, it has tended to “disappear” and its special qualities have become lost since it is regarded as “just a tool” like any other. A contrast is presented between this model of computing focused on facilitating or replacing hand-work and earlier models which prioritised computing’s relation to the mind. The authors note that some other fields seem currently to be reengaging with the idea of computing as something that is not quite like other tools. The article concludes with a list of questions addressed to the design and design research communities based on our analysis.

## Keywords

computing, design research, design history, operational research, art

## Introduction – The Disappearing Computer

The relation between computing and design takes two forms. On the one hand, designers have many opportunities to design devices and systems that utilise computing technology. On the other, designers also use computers as tools to an ever-increasing extent. It is the latter that is our principal focus here, since we want to ask, what kind of tool is the computer? Is historical precedent useful in informing this debate?

In 1991 Mark Weiser began a famous article in *Scientific American* with the words “The most profound technologies are those that disappear. They weave themselves into the fabric of everyday life until they are indistinguishable from it” (Weiser, 1991). A decade later Bill Gates took up the theme, arguing that “Computers, like electricity, will play a role in almost everything you do, but computing itself will no longer be a discrete experience.” (Gates, 2002). Streitz, who was involved in the large European initiative *The Disappearing Computer* 1998 to 2002 and 2003 to 2006 (Streitz, 2007), clarified that such disappearance could take two forms: physical disappearance, due to miniaturization and integration of computing into everyday artefacts such as

clothing; and mental disappearance where devices are no longer perceived as computers but as, say, interactive walls or interactive tables (Streitz, 2001). Such disappearance of the computer has been seen by its protagonists as an unalloyed benefit, and in practice it is proceeding apace. The sale of desktop computers is in long-term decline by contrast with that of tablets and smartphones (IDC, 2013), while the hoped-for embedding of computational ability in everyday objects is being achieved in smart textiles, the Internet of Things, ubiquitous computing, ambient intelligence and so forth. We will suggest that this “disappearance” of computing, while in many ways welcome and perhaps inevitable, may be obscuring some of the potential special qualities of computing, particularly for design and design research.

The disappearance of computing has a counterpart in a significant school of thought in design, often identified with the notion that “the computer is just a tool like any other.” Our historical investigations lead us to think that in an earlier period, when the use of computing in design was new – as was Design Research – an intellectually adventurous, stimulating conceptualization of computing prevailed, raising questions about the nature of computing in design today.

## **Our Context**

Our thoughts here emerge from the beginnings of a project on the early days of Design Research, focusing on the work of Bruce Archer (1922-2005) and some of his colleagues in the Department of Design Research (DDR) at the Royal College of Art, London (RCA), together with our investigations into the work and ideas of R. John Lansdown (1929-1999) who also worked in the DDR from 1983 to 1986, and later at Middlesex University. We have utilised a range of sources: the archives of the DDR at the Victoria and Albert Museum, Archer’s personal archives at the RCA, the John Lansdown Archive at Middlesex University, recent interviews with eye-witnesses to these early events, facilitated by the Computer Arts Society, Design Research Society and others, and privately held recordings of earlier interviews. Though this range of sources is narrow and localised, we believe the range of ideas they represent is remarkably broad. Our paper captures that breadth, as a prelude to deeper studies by ourselves and others.

The mid twentieth century saw the proliferation of new ideas and interest in the inner workings of the brain and body, for example in neural networks and cybernetics, as well as advances in areas such as operations (or operational) research (OR). Dramatic advances in thinking as well as technology emerged from World War II generating new discourses across a diverse range of disciplines, influencing pioneers of the use of computing technology in design such as Archer and Lansdown. They and some of their contemporaries continued to pursue new theories and practice throughout their careers.

As most readers will be aware, Bruce Archer was a major figure in the development of Design Research. From 1956 to 1960 he lectured in Industrial Design Engineering at the Central School of Art and Design, London, and wrote and broadcast as a design critic. For the academic year 1960/61 he was visiting professor at the Hochschule für Gestaltung, Ulm, in West Germany, and then was recruited by Misha Black to be Research Fellow at the RCA, where he developed a programme of research into design methods, while also working on practical design projects including the famous Kings Fund hospital bed (Lawrence, 2001). His location in the broader spectrum of design research is well captured in Frankel and Racine (2010). Early influential publications were *Systematic Methods for Designers* (1965) and *The Structure of Design Processes* (1968). Both show a strong influence of algorithmic thinking, further discussed below. Archer moved significantly away from attempts to make design a science or to capture it algorithmically, instead advocating a view of

design as a third way of thinking on a par with, and distinct from, science and the humanities (1979, based on a lecture of 1976). However, he continued to engage with computing in a variety of ways including promoting an education in the subject to RCA students.

John Lansdown was originally an architect who began investigating the potential of OR and mathematics in architecture in 1960, which subsequently led him to computing as it became more available (Boyd Davis, S, interview with Lansdown, 1988). He was a founder with George Mallen of System Simulation Limited in 1977, a “private research and development company which was originally set up to further the research and computing aspirations of the architectural practice” (Lansdown, 1989). He innovated throughout his career with a diverse range of interests including CAD, Artificial Intelligence, and computer choreography as well as writing regular columns for the *Computer Bulletin*, mostly under the title *Not Only Computer – Also Art*, from 1974-1992. Like Archer, he was influential through serving on important bodies, including the British Computer Society Council (1980-83), and from the early 1970s to the 1990s had influential roles in professional bodies where he was credited with creating a “world leading strategy for developing Computer Aided Architectural Design in UK Universities” (CompArt Database of Digital Art, n.d). He was as interested in art and performance as he was in architecture and design. He was a founder member of the Computer Arts Society (CAS) along with George Mallen and Allan Sutcliffe, and sought to promote a cross-disciplinary understanding of computers. Archer too originally wanted to be an artist. His leisure interests included theatre and ballet (Thorntonian Days, 2007, p.1).

The adventurous, though perhaps confused, spirit of the early days produced a healthy variety of possible models for computing’s relationship to design explored by Archer, Lansdown, and their contemporaries. We offer here a taxonomy and overview of some of these possible relationships, followed by a set of questions that we believe will be of value in making use of this knowledge.

## **Computing and design: a taxonomy**

Like any taxonomy, what follows is the result of a process that demarcates, as though they were discrete, ideas and activities themes that in practice overlapped, and may, to the participants, have appeared under quite a different aspect at the time. We do not suggest that this taxonomy is either complete or definitive, but hope that it may be a useful prompt to further thought and discussion.

### **Computing as a model for systematic designing**

Operations, or Operational, Research (OR) emerged during World War II as a form of systematic decision-making using science-based mathematical and statistical approaches (Miller and Starr, 1960, p.104), focusing on the relation between humans and systems or environments (Ackoff, 1961, p.6). In Simon’s view (1960, p.15) OR converged with the prior tradition of scientific management, expanding the system approach beyond the factory where it had originated. In design, it emphasized sequential processes such as gathering data, and weighting it before proceeding with the design, in contrast to the perceived excess of intuition and tradition in standard design practice. It was his interest in systematic enquiry that led Archer to computing (Figure 1.), as he saw its logic as a way of generating “effective systematic methods for solving design problems” (Archer, 1963, p.1). He also saw ways of thinking about computing as “valuable indicators of the sort of logic which might work even without a computer” (ibid). Archer described the systematic approach as one where “A logical

model of the design process is developed, and a terminology and notation is adopted which is intended to be compatible with the neighbouring disciplines of management science and operational research” (Archer, 1968, Foreword), echoing Simon’s (1960) view that systems approaches were a frame of mind as much as a formal theory.

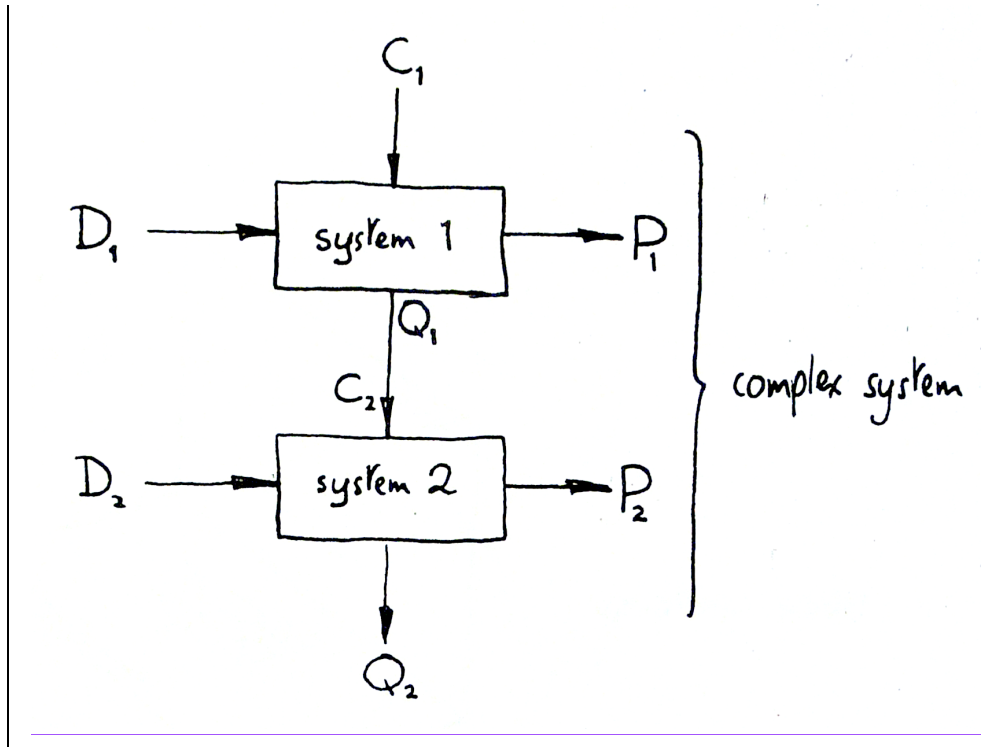

Figure 1. Diagram “An incidental variable from one system may be a context variable in another.” Figure 3.7 from the appendix of Archer’s 1968 doctoral thesis at the RCA, *The Structure of Design Processes*. This is one of many similar diagrams appearing in the thesis, hinting at Archer’s fascination with algorithmic systems.

## The influence of cybernetics

Though many pioneers were involved in both cybernetics and OR, they are, as Pickering (2002) has pointed out, conceptually distinct. While OR emerged from the management of man-machine processes, cybernetics originated as much in the feedback and control mechanisms of war machinery as in human contexts. It retained, and still retains, some of this emphasis on embodiment and the physical. Wiener’s (1948) idea attracted interest from diverse disciplines such as engineering and sociology, philosophy and physics and at the Macy conferences on cybernetics between 1946-1953 researchers “struggled to understand one another and make connections between others’ ideas and their own areas of expertise” (Hayles, 1999, p.51). Nevertheless, it was these struggles that pushed the boundaries forward.

In design, the influence of cybernetics involved a particular emphasis on feedback and auto-reconfiguring, supporting a model where design does not follow research, but interacts with it. Figures such as Beer, Pask and Ashby in Britain were particularly influential on researchers such as Bruce Archer – who cited all three in the bibliography to his thesis (Archer, 1968) – and George Mallen, discussed below. More recently, in a series of works over several years, Glanville (eg. 2007) has explicitly pursued the relationship between cybernetics and design: he exemplifies an important minority tradition within design research, of relating computing to philosophical ideas within a design context.

## Reflexive computational models

If the use of OR or cybernetics harnessed computationally-inspired methods to improve design, the reflexive approach to computing asked the opposite question: “If I attempt an algorithm for designing, or try to capture design knowledge digitally in some other way, what do I learn about design?” There are clear signs of such an approach in Archer’s work. Indeed, he claimed only to undertake major design projects like the hospital bed in order to augment his understanding of design (C Frayling, pers. comm. to S. Boyd Davis. 10 June, 2013). The approach is analogous to contemporary uses of artificial intelligence in cognitive science, which was investigated not just to discover whether machine intelligence might surpass or supplement human intelligence, but also to model the processes of human cognition in order to better understand them (Boden, 2006). Indeed, the premise of AI was the assumption that “every aspect of learning or any other feature of intelligence can in principle be so precisely described that a machine can be made to simulate it.” (McCarthy, Minsky, Rochester and Shannon 1955). Ashby’s *Design for a Brain* (1960) exemplifies similar reflexive thinking within cybernetics.

## Qualitative computing

While much of our taxonomy is concerned with ideas that were enacted in practical form, we discuss here an approach that at the time was only an idea, and arguably remains so. Archer (1972) discusses two complementary uses of computing in a short but important paper, ostensibly about architecture but with relevance to all design, concerned with what he terms the *quantitative* and *qualitative*. By *quantitative*, in this context, he refers to the use of computing to undertake those relatively mechanical tasks that the architect must undertake but which practitioners regard as ethically less important than the “comfort, convenience, aesthetics, amenity and the expression of Man’s spirit, that architecture is all about” (op. cit. p.1). The main point of the paper was to address this key area as one where computers were *not* being used – “the patterns of goals and values of the people concerned” and “the relations between the attributes to which people attach value, and the objectives which they are trying to pursue” (op. cit. p.4). Part of his argument is technical: that computers can process anything that can be symbolised, not just numeric data. But this is followed by a zealous appeal for computer systems to be designed and used to support the qualitative, humanistic, ethical practices that architects and designers pride themselves on: he saw “no reason why computer models should not be built for the handling of qualitative considerations.” (p.3)

Lansdown also posited ideas and examples of programs as early as 1970 where he describes different symbols, such as letters, words, objects, and so on, that would represent a vocabulary that would enable the programmer to “simulate creativity in widely differing areas” (Lansdown, 1985, p. 9). Also in 1972, at the same conference as Archer, Lansdown presented a way that computers could deal with certain qualitative aspects, for example by “monitoring of activities and responses, much more subtle and continuous control over environmental factors” would provide feedback for learning programs to “optimise comfort conditions”, in essence, giving information “for more responsive future design” (Lansdown, 1972, p3). In this paper, Lansdown suggested that design should learn from the arts, while Archer cited social science methods for dealing with qualitative information. This diversion into other fields of study was not unusual for either of them. Archer is known to have seen the importance of other departments at the RCA including those relating to the history of art and design (Margolin, 2010, p.2). Margolin notes that Archer’s approach was

“more flexible than some of his colleagues in characterizing design as a practice that lay somewhere between science and art” and “saw a relation between cultural research and design” (ibid).

## **Contextual computing**

Also more an aspiration than a practice, contextual computing was intended to use information technology to provide knowledge relevant to the designer at the point of action. Lansdown (1989, p.5) assumed that “we cannot design anything without proper information and knowledge” and suggested that design failures do not necessarily amount to bad designing, but bad working practices. The computer was suggested as a facilitator to improve the “designer’s information environment” by ensuring that the practitioner had ready access to the wealth of existing knowledge: “it is clear that most design failures arise not because designers are working to the boundaries of current knowledge in their particular disciplines. They generally arise because designers have not employed well-understood and often well-documented principles, procedures, and practices” (op. cit. p.5). With the computer acting as a source of relevant information, the designer would have all the necessary knowledge throughout the process of designing, particularly at the beginning stage where it was “difficult to obtain task knowledge by conventional means” (op. cit. p.6). This would improve design practice by providing a designer’s environment where the “machine can help creative people become more effective” (1985, p. 13-14).

## **Educating the designer: simulation**

A landmark of early computing for design was Ecogame, developed by a team under Mallen, by request of the British Equipment Trade Association, for the *Computer '70* trade exhibition (Mallen, 2008, p.194 ). Like most other categories in our taxonomy, this aimed, not to relieve the designer of hand work, but to illuminate the mind. A computer-managed simulation with output in the form of slide-projected images on the interior of a physical dome, it enabled the user to explore what-if scenarios with a given set of ecological resources. Mallen graduated in physics and was originally an aeronautical engineer at Farnborough, he also worked part time in Archer’s department from 1970, and with Lansdown co-founded System Simulation in 1977 (where he is still an active director of research). Like many of his contemporaries Mallen disregards discipline boundaries; while Ecogame was initially seen by many as an artwork (Edmonds and Franco 2010), and the idea conceived at a meeting of the CAS (Mallen, 2008, p.194) a version was commissioned for the First European Management Forum in Davos in 1971 (Lambert, 2011). As Lansdown (1988) remarked “The ground-breaking Ecogame exhibit at Olympia in 1970 showed how computer art could change our way of thinking about environmental problems (and, incidentally, about computing too)”. Mallen commented in retrospect that “it was very high risk but those of us involved were hopelessly optimistic and totally committed, which are key factors in an innovation” (Mallen, 2008, p. 194).

## **Dialogical computing**

The influential book *Soft Computing – Art and Design* (Reffin Smith, 1985) sets computing in a broad intellectual context. The “softness” of the title is reflected in the author’s emphasis on the qualitative and it is worth recalling that he too was situated in Archer’s department at the RCA as a research fellow, and college tutor from 1979-1984, principally to educate the college’s own students in computing.

Reffin Smith remarks that “we ought sometimes to consider the use of computers to handle representations, and we ought to be aware of what’s going on when we do that.” (op. cit. p.102). It is notable that the word “representations” does not limit the discussion to the visual or even the sensory; it may just as well refer to ideas perhaps expressed in language. An apparently trivial example of computer use offered by Reffin Smith is a 52-line program in the simple computer language BASIC (op. cit. p.57-8). The program invites the user to name an entity, for example “chair”, and then to assign six descriptive attributes to it. The user is then invited to provide six alternatives to each attribute, preferably not thinking of the original entity. The program then offers a new description of that entity using six attributes chosen at random from the alternative sets the user just provided. In terms of design thinking, this is no more than the mechanisation of a creativity prompting scheme, less sophisticated computationally even than ELIZA (Weizenbaum, 1966) of twenty years earlier, but this apparently simple example goes to the heart of a debate on mechanism and creativity since computing’s earliest days. Turing in 1950 had discussed “Lady Lovelace’s objection” (Menabrea and Lovelace 1842), which he paraphrases as the idea that “a machine can never take us by surprise,” and which he suggests is based on the fallacy that the human mind needs no assistance in making new thoughts based on the information it already holds (Turing 1950). Such assistance, achieved in a quasi-conversational manner, is just what Reffin Smith’s program is designed to illustrate. The program elicits inputs from the user, minimally reconfigures them, and returns them to the user for reconsideration. Lansdown (1988) also notes that “by making composite analogies, new and more complex relationships- and hence, new design ideas - can be generated.” A far more complex interpretation of this approach is the “expert system”, which augments the user’s input using a database of suitably codified knowledge. Such systems were also of great interest to Lansdown, particularly for use in design and architecture. In 1980 he suggested that “the next generation of CADs will be expert systems with very realistic graphics. There will be no need to build models as the computer graphics will be more lifelike than the models themselves” (Lansdown, 1980, pp10-11). He recognised that “for the UK to keep its lead in CAD we need to think what the next generation of computers will be like” (Lansdown 1982), in his successful application for the RIBA Conference fund fellowship, which he used to produce the influential report entitled *Expert Systems – Their Impact on the Construction Industry* published in 1982.

## **Computers as tools**

From Babbage (1791-1871) onwards, one of the most obvious applications of computational machinery has been to relieve humans of tedious, error-prone, repetitive tasks, an approach with origins in pre-computer devices such as the Jacquard loom and Tull’s seed drill. Archer discusses such uses of computing in the paper on the qualitative discussed above (Archer 1972). He assesses claims that “the computer could free the architect from burdensome preoccupation with (largely quantitative) chores and thus permit him to spend more of his time and energy on the handling of the (mainly qualitative) broader issues” (p.1). In this paper, Archer shows strong reservations, based on his examination of computing in engineering design, as to whether such freeing does in fact occur.

Lansdown observed that because of the number of different staff “comprising architects, engineers, town planners, interior and graphic designers, our approach was essentially a pragmatic one aimed at treating the computer as a tool commissioned to help the designer and analyst where it could whilst leaving their basic functions unchanged” (Lansdown, 1970, p.5). Perhaps more sanguine than

Archer, he thought that by using the computer to do easily what might be difficult to do by hand, “the effect on the creative process can be profound” (1985, p.19).

There is no doubt that the computer has subsequently augmented or replaced many craft operations, usually on an assumption that (1) time will be saved and (2) the saved time will be spent on more rewarding aspects of designing. Examples abound: computer-aided drafting and modelling in architecture, vehicle design, fashion and many other disciplines; non-linear editing systems replacing cutting and splicing of film or tape; rapid prototyping and manufacture; the list goes on. To an increasing extent, systems were deliberately designed to imitate traditional tools and practices (Quantel 1986, 1987). This was the same period when the Macintosh interface popularised skeuomorphic conceits such as trash cans, folders and desktops on the computer screen, all designed to make the computer as unchallenging – and indeed as unlike a computer – as possible. This notion of the computer as a tool, one that is no more important intellectually than a trowel, an airbrush or a scalpel, but is rather a prosthetic extension of the hand, is arguably the dominant one of our time.

The categories of early design computing that we discussed above, however, are predominantly concerned with the designer’s mind. They emerged from an optimistic tradition in relation to computing where the machine augments mental capability, exemplified by Bush’s *As We May Think* (1945), Engelbart’s *Augmenting Human Intellect* (1962), Nelson’s *Literary Machines* (1980) and Berners-Lee’s *Information Management: a proposal* (1989), the foundational document of the World Wide Web. Again, these key texts are not primarily about easing hand-work. If computers here are tools, they are tools principally for the mind.

## **Meanwhile, beyond design...**

The move to regard the computer as just a (hand) tool has tended to obscure the exciting range of possibilities that our small group of pioneers explored forty or more years ago. In that time, however, other fields have also been changing.

## **Changes in the nature of computing**

Since the historic period on which we have focused, there have been significant changes in the theory and practice of computing. In addition to the “disappearance”, both physical and mental, discussed above, notable changes include the international interoperation made possible by the Web, the growth of digital entertainment, and the escape of computing from the boundaries of the screen into the world of the physical.

In another way, computing has altered since the time when it was taken as a model for linear, algorithmic, systematic approaches to design. For example well-known approaches such as, “agile development” is a software engineering approach that might even be said to have learned from design. It rejects the linear model where requirements must first be gathered and weighted before design can begin, proceeding instead through early development activities that feed back into re-definitions of the needs. One of its tenets is to prefer “responding to change, over following a plan” (Beck et al. 2001). Lansdown (1983) remarked that “Design is not an algorithmic process in which the designed conclusions can be reached by the operation of step-by-step procedures – first finalising this aspect, then that. It is a fluid, holistic process wherein at any stage all the major parts have to be manipulated at once”(p.3). Agile development attempts to take this process to software engineering.



Another emerging trend of parallel processing, the simultaneous processing of information, avoids some of the linearity of approach that formerly characterised all computing, while biological computing takes us further still from what we thought computing was, towards flexible, robust, self-organising systems that will arguably be neither digital nor computational (Bentley 2001).

Currently the digital development rousing attention in the design community is rapid prototyping and manufacture. Clearly this will have radical effects on the roles of designer, maker, seller and user, and facilitate making objects that were previously difficult or impossible (Hague, Campbell and Dickens 2003; Lederer, King and Logan 2010). Yet, ironically this is another development of design computing that principally augments or substitutes for the work of the hand.

## **The reappearing computer**

In a number of other fields, an eagerness to grapple with the special nature of computing has re-emerged, which seems to be at odds with the computer-as-tool metaphor. As illustration, we briefly cite three examples.

In musical and sound performance, there has been an increasing desire to engage with computing as a distinctive form of expression. Programmers appear on stage, writing code in real time, typically the code being projected for the audience to view, emphasising a creative role for programming analogous with sketching, exploring and improvising (Collins, McLean, Rohrhuber and Ward 2003; Magnusson 2011). Lansdown remarked in 1988 that “*Interact* at the Edinburgh Festival of 1972 showed once again the importance we attached to live computing and performance arts because, even in the early days, we saw the danger of equating all computer art with computer graphics” (p.2). Lansdown clearly saw that computer graphics used computing merely as a tool, as a means to an end, and that this was a limiting conceptualisation.

Additionally, the proliferation of the “Maker Faire” worldwide, from the first in California in 2006, and similar events, have again brought technology and its possibilities to the forefront, encouraging the wider public to engage with fundamentals of computing technology. Hack spaces and geek communities are now prolific. To take just one small area of the UK as a sample, Preston GeekUp, part of a larger group of communities for “tech-minded folk” (Geekup.org) holds regular events; Manchester Mad Lab, a “Digital Laboratory” aims to facilitate connections between those “who’ll get out of the usual zones”, hoping to exchange ideas between individuals as diverse as knitters and software architects (madlab.org.uk); while a 24hr Hackathon was held at the Museum of Science and Industry as part of the Manchester Science Festival (27<sup>th</sup> and 28<sup>th</sup> October 2013). Similar groups and events are now active world-wide, apparently evidence of a desire to get back to the roots of technology in creative and innovative ways, especially by sharing ideas and skills from diverse areas.

In the UK at the time of writing, there is also a surprising curricular shift in computing for schools. In 2011, Eric Schmidt, chairman of Google, told the Edinburgh International Television Festival that the UK “had invented computers in both concept and practice” but now was throwing away its great computer heritage by failing to teach programming in schools. He commented, “Your IT curriculum focuses on teaching how to use software, but gives no insight into how it’s made.” (*Guardian*, 2011). From 2014, the new computing curriculum shows that even at the earliest stages (Key Stage 1, ages 5-7) pupils will be taught about algorithms and basic programming concepts so that they can evaluate and apply information technology, including new or unfamiliar technologies, analytically (Department for Education,

2013). However, the new design curriculum rather narrowly focuses the use of computing on students being able to “apply their understanding of computing to program, monitor and control their products” (Department of Education, 2013). Further recommendations for international standards in computing education at undergraduate level have also been recently revisited by the ACM and IEEE-Computer Society, and represent a ‘comprehensive revision’ of their 2001 guidelines (CS2013 p.10) based on rethinking essential components in a changing and expanding field.

## Digital Design Research

We have set out to ask, what kind of tool is the computer, and is historical precedent useful in answering this question? The principal conclusion we draw from our studies is the need for an agenda for digital design research, one that is informed by the wide-ranging approaches and innovative development from the pioneering period. We suggest a need to reconsider the nature of computing – and its implications for design – and embed that thought into the philosophy of design and design research. In a recent keynote, Brian Reffin Smith (2010) remarked “What comes after ‘computer art’ depends on revisiting past concepts not fully explored. A true revolution involves seeing the past before returning to change the present.” Perhaps the same is true of computing in design.

In conclusion, we offer some questions, prompted by our research, to help shape the agenda. We are not of course suggesting that these questions are all new. Indeed, several of them are being addressed in focused pockets of specialist research that it would take another whole paper to account for.

1. What, if anything, of value can be learned from studying the theory and practice of computing in design in its earliest days?
2. Do we need a richer framework to conceptualise the relation between computing and design?
3. How best can thinking about computing be embedded in the philosophy of design, and design research?
4. Are we sufficiently aware of the changes in the nature of computing? How can we best remain up to date in future?
5. The cross-fertilisation between computing in art, music, performance and the sciences seemed to serve the pioneers well: could the same be true today?
6. What is our attitude to the potential intervention of computing in the cultural, aesthetic, humanistic, qualitative aspects of design?
7. Which investigative tasks are most urgent in documenting this early history?
8. Finally, what should students be doing, and learning, concerned with computing in design?

## Acknowledgements

Simone Gristwood is funded by the Paul Mellon Centre for Studies in British Art as a part-time research curator in the John Lansdown Archive, Middlesex University, 2012-2015. We are also grateful to Neil Parkinson, archivist at the RCA, to staff of the V&A Archive of Art and Design at Blythe House, to the RCA Research Development Fund, the Art and Design Research Institute at Middlesex University and Moad Musbahi, student volunteer, Lansdown Project.

## References

- Ackoff, R. L. (1961) *Progress in Operations Research. Volume 1*. New York: John Wiley and Sons.
- Archer, L. B. (1963) *Lecture to Architectural Association School of Architecture, Thursday 26 September 1963 Systematic methods – friend or foe?* Unpublished lecture notes, Bruce Archer Archive, Royal College of Art
- Archer, L. B. (1965) *Systematic Method for Designers*. London, The Design Council
- Archer, L. B. (1968) *The Structure of Design Processes*. Springfield, Va: U.S. Department of Commerce
- Archer, L. B. (1972) Computers, design theory and the handling of the qualitative *Proceedings of the International Conference on Computers in Architecture, University of York, 20-22 September 1972*
- Archer, L. B. (1979) *Design as a Discipline*. Based on a lecture delivered at the Manchester Regional Centre for Science and Technology on 7 May 1976. *Design Studies* 1(1). 17-20.
- Ashby, W. R. (1960) *Design for a Brain: the origin of adaptive behaviour*. London: Chapman and Hall.
- Association of Computing Machinery and IEEE Computer Society Joint Task Force on Computing Curricula (2013, December 20) *Curriculum Guidelines for Undergraduate Degree Programs in Computer Science*. Retrieved March 14 2014, from <http://www.acm.org/education/CS2013-final-report.pdf>
- Beck, K, Beedle, M, van Bennekum, A, Cockburn, A, Cunningham, W, Fowler, M et al. (2001) *Manifesto for Agile Software Development. Agile Alliance*. Retrieved November 6, 2013, from <http://agilemanifesto.org/>.
- Bentley, P. J. (2001) *Digital Biology: How Nature is Transforming Our Technology and Our Lives*. New York: Simon and Schuster.
- Berners-Lee, T. (1989) *Information Management: A Proposal*. Geneva: CERN. Retrieved November 6, 2013, from <http://www.w3.org/History/1989/proposal.html>
- Boyd Davis, S. (21 July 1988) Interview with John Lansdown, London.
- Boden, M.A. (2006) *Mind as Machine: A History of Cognitive Science*. Oxford: Clarendon.
- Bush, V. (1945, July) As We May Think. *The Atlantic Monthly*. Retrieved October 13, 2013 from <http://www.theatlantic.com/magazine/archive/1945/07/as-we-may-think/303881/>
- Collins, N., A. McLean, J. Rohrhuber, and A. Ward (2003). Live coding in laptop performance. *Organised Sound*. 8(3). 321-330
- Compart Database of Digital Art *Robert John Lansdown*. Retrieved November 7, 2013 from <http://dada.compart-bremen.de/item/agent/187>
- Department for Education (2013, September 11) *National curriculum in England: computing programmes of study*. Retrieved November 7, 2013, from <https://www.gov.uk/government/publications/national-curriculum-in-england-computing-programmes-of-study>
- Department for Education (2013, September 11,) *National curriculum in England: design and technology programmes of study*. Retrieved November 7, 2013, from

<https://www.gov.uk/government/publications/national-curriculum-in-england-design-and-technology-programmes-of-study>

Edmonds, E. and Franco, F. (2010, February 3) Art of Conversation. *Symposium CAT 2010: Ideas before their time : Connecting the past and present in computer art.* (pp. 24-31). British Computer Society, London.

Engelbart, D. C. (1962). Augmenting Human Intellect: A Conceptual Framework. (SRI Summary Report AFOSR-3223. SRI Project No. 3578). Retrieved October 13, 2013, from <http://www.dougelbart.org/pubs/augment-3906.html>

Frankel, L and Racine, M (2010, July) The Complex Field of Research: for Design, through Design, and about Design. *Proceedings of the Design Research Society International Conference 'Design & Complexity'*. University of Montreal

Gates, B. (2002), The disappearing computer, reprinted from *The World in 2003*, The Economist Group. Retrieved November 7, 2013, from <http://www.microsoft.com/presspass/ofnote/11-02worldin2003.msp>

Glanville, R (2007) Try again. Fail again. Fail better: the cybernetics in design and the design in cybernetics. *Kybernetes* 36 (9/10). 1173-1206.

*Guardian* (2011, August 26) Eric Schmidt, chairman of Google, condemns British education system. James Robinson, *The Guardian*

Hague, R., Campbell I. and Dickens, P (2003, January) Implications on design of rapid manufacturing. *Proceedings of the Institution of Mechanical Engineers, Part C: Journal of Mechanical Engineering Science*, 217 (1) 25-30

Hayles, N. K (1999) *How We Became Posthuman : Virtual Bodies in Cybernetics, Literature, and Informatics*. Chicago: University of Chicago Press

IDC (International Data Corporation) (2013, April 10), *PC Shipments Post the Steepest Decline Ever in a Single Quarter*, Framingham, Mass. Retrieved October 25, 2013, from <http://www.idc.com/getdoc.jsp?containerId=prUS24065413>

Lambert, N. (2011, Spring) Chair's Letter, *Page: the Bulletin of the Computer Arts Society*, 1

Lansdown, J (1970) *The time-sharing computer in an architects [sic] practice*, John Lansdown Archive, Middlesex University, JLA/1/1/15 Box 1

Lansdown, J (1972) *Computing and the Design Function of the Architect* proceedings of the International Conference on Computers in Architecture, University of York, 20-22 September.

Lansdown, J (1980, September 12) in *Building Design* No 512 (pp.10-11)

Lansdown, J (1982) *Expert Systems: Their Impact on the Construction Industry* Royal Institute of British Architects, London

Lansdown, J (December 1983) *The Impact of SERC funding on CAAD and Design Methods* Report to the Computer Aided Building Panel, Science and Engineering Council, John Lansdown Archive, Middlesex University, JLA/1/2/1 Box 3

Lansdown, J (1985) *Computing in the Creative Professions* John Lansdown Archive, Middlesex University, JLA/1/1/17 Box 1

Lansdown, J (1988) *Computer Art: A Personal Reminiscence*, Exhibition Catalogue Introduction, Cleveland Arts Centre, John Lansdown Archive, Middlesex University, JLA/1/2/4

Lansdown, J (1988) Graphics, Design and Artificial Intelligence in Earnshaw (Ed.) Theoretical Foundations of Computer Graphics and CAD Berlin, Springer

Lansdown, J (c. 1989) *Note on Blinn's August 1980 talk at Brighton* John Lansdown Archive, Middlesex University, JLA/1/2/01

Lansdown, J (1989) The designer's information environment: some tools for design knowledge manipulation, *Civil Engineering Systems*, 6(1-2), 5-10, DOI: 10.1080/02630258908970537

Lawrence, G (2001). *Hospital beds by design: a socio-historical account of the 'King's Fund Bed', 1960-1975*. Unpublished PhD Thesis, University of London. Retrieved October 26, 2013, from <https://archive.org>

Lederer, R, King, B and Logan, H. (2010). Transformative Design: From Consultant to Clinician. *Proceedings of the Design Research Society International Conference 'Design & Complexity'*. Université de Montréal, Montreal, Canada, 7-9 July 2010.

Magnusson, T. (2011). Algorithms as Scores: Coding Live Music, *Leonardo Music Journal* 21. 19-23

Margolin, V (2010) Design Research: Towards a History. *Proceedings of the Design Research Society International Conference 'Design & Complexity'*. Université de Montréal, Montreal, Canada, 7-9 July 2010.

Mallen, G (2008) Bridging Computing in the Arts and Software Development. In P Brown, C Gere, N Lambert and C Mason (Eds.) *White Heat, Cold Logic. British Computer Art 1960-1980* (pp. 191-202) Cambridge, Massachusetts, MIT Press

McCarthy, Minsky, Rochester and Shannon (1955, August 31) A Proposal for the Dartmouth Summer Research Project on Artificial Intelligence. Retrieved October 10, 2013, from <http://www.formal.stanford.edu/jmc/history/dartmouth/dartmouth.html>

Miller, D. W. and Starr, M. K. (1960). *Executive Decisions And Operations Research*. Englewood Cliffs, N.J: Prentice Hall.

Nelson, T (1980) *Literary Machines*, Sausalito CA: Mindful Press.

Pickering, A (2002) Cybernetics and the Mangle: Ashby, Beer and Pask. *Social Studies of Science* 32(3). 413-437.

Quantel (1986) Improvements in or relating to video image creation systems (Patent EP 0202747 A2)

Quantel (1987) Improvements in or relating to electronic graphic systems (Patent EP 0245943 A2)

Reffin Smith, B (1985) *Soft Computing: Art and Design*. Wokingham UK: Addison-Wesley

Reffin Smith, B (2010, February 3) Post Computer Art – Ontological Undecidability and the Cat with Paint on its Paws. *Symposium CAT 2010: Ideas before their time : Connecting the past and present in computer art*. (pp. 1-7) British Computer Society, London

Simon, H. A. (1960) *The New Science of Management Decision*. New York: Harper and Brothers.

Streitz, N. A. (2001). Augmented Reality and the Disappearing Computer. In Smith, M., Salvendy, G., Harris, D., Koubek, R. (Eds.), *Cognitive Engineering, Intelligent Agents and Virtual Reality* (pp. 738-742). Lawrence Erlbaum

Streitz, N (2007).; The Disappearing Computer. In Kameas, Achilles; Mavrommati, Irene (Eds.) *Interaction Design, System Infrastructures and Applications for Smart Environments. Lecture Notes in Computer Science 4500*. Berlin: Springer.

Weiser, M. (1991, September) The Computer for the Twenty-First Century. *Scientific American* 265(3). 94-104.

Wiener, N (1961) *Cybernetics, or Control and Communication in the Animal and the Machine*, 2nd edition, Cambridge, MA: M.I.T. Press

Throntonian Days (2007) Remark by Miranda Newton (Bruce Archer's daughter) in a brief obituary in *Thorntonian Days: Newsletter of the Old Thorntonians Association* (Clapham) No.2 May 2007. Retrieved November 8, 2013, from [http://www.oldthorntoniansclapham.org.uk/USERIMAGES/ota\(c\)\\_newsletter\\_no\\_2.pdf](http://www.oldthorntoniansclapham.org.uk/USERIMAGES/ota(c)_newsletter_no_2.pdf)

Turing, A (1950) Computing Machinery and Intelligence *Mind* 59 (236): 433-460. Retrieved November 1, 2013, from <http://orium.pw/paper/turingai.pdf>

Menabrea L.F. and Lovelace, A.L. (1842) Sketch of the Analytical Engine Invented by Charles Babbage by L. F. Menabrea of Turin with Notes upon the Memoir by the Translator Ada Augusta, Countess of Lovelace. *Bibliothèque Universelle de Genève*, October, 1842, No. 82.

Weizenbaum, J (1966), ELIZA—A Computer Program For the Study of Natural Language Communication Between Man And Machine, *Communications of the ACM* 9(1).

### **Simone Gristwood**

Dr Simone Gristwood is currently Lansdown Research Curator at Middlesex University funded by the Paul Mellon Centre for Studies in British Art to work with the archive of R. John Lansdown, pioneer of the use of computers in art and design. She received her PhD from Lancaster University in 2010. Her thesis investigated links between the beginnings of photography in the 19th century and artificial intelligence (AI) in the 20th, through art historical and philosophical debates. She has worked on numerous archives including that of Japanese pioneer Hiroshi Kawano (1925-2012) at ZKM|Zentrum für Kunst und Medientechnologie in Germany, and has met and interviewed both Kawano and Masao Kohmura of the Computer Technique Group (CTG) when visiting Japan in 2009. More recently she has worked with the Royal College of Art to rediscover the work of L. Bruce Archer through his personal archive and the archive of the Department of Design Research (Royal College of Art) that is held at the Victoria and Albert Museum, London.

### **Stephen Boyd Davis**

Dr Stephen Boyd Davis leads staff research activities in the School of Design at the Royal College of Art. Originally a textile designer, Stephen has for many years been involved in the creative use of digital technologies, most recently in locative media where digital material escapes the boundaries of the screen and becomes part of our experience in the world. Until 2011, he was Reader in Interactive Media and head of the Art and Design Research Institute and the Lansdown Centre for Electronic Arts at Middlesex University. Stephen is a panel member for REF2014, and is a reviewer for three UK research funding councils and for leading journals and conferences. His research has been funded by the Paul Mellon Centre for British Art, the Leverhulme Trust, Wellcome Trust, ESRC, EPSRC and industry. He advises leading companies and organisations. Stephen's personal research is mainly concerned with the visual representation of historical time, especially in interactive digital media. This research combines historical investigation and the development of new digital practice. He has a deep interest in the history of creative engagements with computing.