

See discussions, stats, and author profiles for this publication at: <https://www.researchgate.net/publication/303972540>

# Power Management of AC Islanded Microgrids using Fuzzy Logic

Conference Paper · April 2016

DOI: 10.1049/cp.2016.0348

---

READS

51

4 authors, including:



Walid Issa

University of Exeter

10 PUBLICATIONS 10 CITATIONS

SEE PROFILE



Tapas K Mallick

University of Exeter

187 PUBLICATIONS 1,156 CITATIONS

SEE PROFILE

# Power Management of AC Islanded Microgrids using Fuzzy Logic

*R Al Badwawi, W Issa, T Mallick, and M Abusara*

*Environment and Sustainability Institute, University of Exeter, Penryn Campus, Penryn, TR10 9FE, United Kingdom,*

\*Correspondence: Email: [rsma202@exeter.ac.uk](mailto:rsma202@exeter.ac.uk) Tel: +44(0)1326259478.

**Keywords:** Fuzzy logic controller, power management, microgrid, energy storage system, renewable energy sources.

## Abstract

In an islanded AC microgrid consisting of renewable energy sources, battery, and load, the battery balances the difference between power generated by renewable sources and that consumed by the load. However, battery charging capacity is limited and its state of charge needs to be maintained within the safety limits. Furthermore, battery has limited maximum charging and discharging power. This paper proposes a controller based on fuzzy logic to prevent the battery state of charge and charging/discharging power from exceeding their limits regardless of variations in load and intermittent power of renewable sources. The microgrid considered in this paper consists of PV, battery, load and auxiliary supplementary unit. The fuzzy logic controller alters the AC bus frequency which is used by the local controllers of the parallel units to curtail the power generated by PV or to supplement power from the auxiliary unit. The main merits of the proposed controller are simplicity and easiness of implementation without the need for any communication links between the parallel units. Matlab/Simulink results are presented to validate the performance of the proposed controller.

## 1 Introduction

AC microgrid can provide an elegant and efficient solution for integrating Renewable Energy Sources (RES). A microgrid is basically an aggregation of RES, Energy Storage Systems (ESS), and local loads. It can operate in grid-connected mode as well as in autonomous island mode. In grid-connected mode, the bus voltage and frequency are maintained by the grid and any difference between the power generated by RES and that required by the load is balanced by the grid. The ESS in this case can be used to control the amount of power exchanged between the grid and the microgrid. In island mode, however, ESS has to play a much more important role; it has to maintain the bus voltage and frequency and it needs to balance the difference between the RES power and load. Due to the limited charging capacity of ESS, power generated from RES might need to be curtailed to prevent the ESS from overcharging. Similarly, the load might need to be shed or an auxiliary power unit might need to supplement power in order to prevent the ESS from undercharging. In addition, battery ESS (BESS) has limited maximum charging and discharging power and exceeding this will reduce the lifetime of the battery. Therefore, the energy management controller has to fulfil two main tasks; firstly,

the State of Charge (SOC) of the battery has to be maintained between the maximum and minimum limits and secondly, the battery power needs to be kept below the maximum charging/discharging limits.

Fuzzy Logic Control (FLC) is a flexible tool with rules based on human knowledge and experience that can deal with unpredictable variables or uncertainties. FLC can deal with complex systems such as microgrids with different types of imprecise inputs, variables and disturbances in particular if the power is supplied by intermittent RES and consumed by varying and unpredictable load. FLC has been used for both DC and AC microgrids (grid-connected and island mode of operations) in the literature for several purposes due to its good performance and simplicity. FLC has been used for Maximum Power Point Tracking (MPPT) of solar PV [1–5], frequency regulation [6,7], controlling batteries' output charger current [8] and improvement in wind power prediction accuracy [9].

Several publications have also been published on using FLC for energy management of microgrids consisting of hybrid RES (PV and wind) and BESS [10,11]. In [12, 13], FLC has been used to provide a proper split in power between solar PV, wind and BESS according to a pre-defined rules based on the operator's experience. A FLC was used to manage the SOC of a Li-ion battery in a DC microgrid with solar PV, wind and fuel cell system [14]. There were two inputs to the FLC; power difference between generation and load and difference between measured SOC and required SOC. The output of the FLC was the charging/discharging current demand for the battery.

In grid-connected mode, a FLC was proposed in [15] to minimize energy storage range of the battery and power variation range exchanged between the grid and the microgrid. The FLC inputs were power difference between generation and load and the difference between battery capacity status and its half-rated capacity. Battery demanded power was the output of the FLC. A smart FLC was also proposed in [16] in order to minimize the number of times required to switch between island and grid-connected modes. This in turn maximized the usage of renewable energy and reduced the dependency on the main grid.

The SOC of a BESS in a hybrid microgrid was controlled by a FLC in [17] to improve the performance of the hybrid generation system with smaller energy capacity of BESS. In [18], two FLCs were used for optimal battery charging and discharging using two loops. The outer control loop used

power difference between wind power and load. The inner control loop used the relative temperature of battery to indoor temperature. The output variable was the charging voltage. A decentralized fuzzy logic gain-scheduling controller was proposed in [19] to balance the stored energy between different battery systems in a DC microgrid by adjusting the droop coefficients of the primary controllers. A controller was proposed for an autonomous active power control of islanded AC microgrids with PV and ESS along with load in [20]. The controller was based on frequency bus-signalling such that the ESS controls the PV power using local controllers and without the need for external communication.

In this paper, a FLC is proposed to control BESS in an islanded microgrid. It prevents the battery SOC and power from exceeding their maximum and minimum limits regardless of variation in load and intermittent power generated by renewable sources. The microgrid considered in this paper consists of PV, battery, load and auxiliary unit which can be a fuel cell, micro gas turbine or another battery. The fuzzy logic controller (located in BESS) alters the AC bus frequency which is used by the local controllers of the parallel units to curtail the power generated by PV or to supplement power from the auxiliary unit. The FLC is divided into two subsystems to simplify the design. The main merits of the proposed controller are simplicity and easiness of implementation without the need for any communication links between the parallel units. Matlab/Simulink results are presented to validate the performance of the proposed controller.

## 2 System Overview and Droop Control Strategy

The microgrid considered in this paper is shown in Fig.1. It contains three power generation units:

- 1) PV-based RES unit which consists of a unidirectional DC/DC converter and a DC/AC inverter. The DC/DC converter controls the PV output voltage to achieve MPPT while the DC/AC inverter regulates the DC link voltage.
- 2) BESS unit which has a bidirectional DC/DC converter to regulate the DC link voltage while the DC/AC inverter represents the master unit that maintains and controls the AC bus frequency and voltage of the islanded microgrid. It also alters the bus frequency according to FLC command.
- 3) Auxiliary supplementary unit which can be a fuel cell, micro-gas turbine, or another battery. It operates in case of low battery SOC and/or low PV generation. It has a unidirectional DC/DC converter that regulates the DC link voltage while the DC/AC inverter controls the output power according to the AC bus frequency as will be explained later.

All the three DC/AC inverters use droop control [21] to stay in parallel and share load. If the power generated by the PV unit is more than the load, the battery unit will absorb the surplus power.

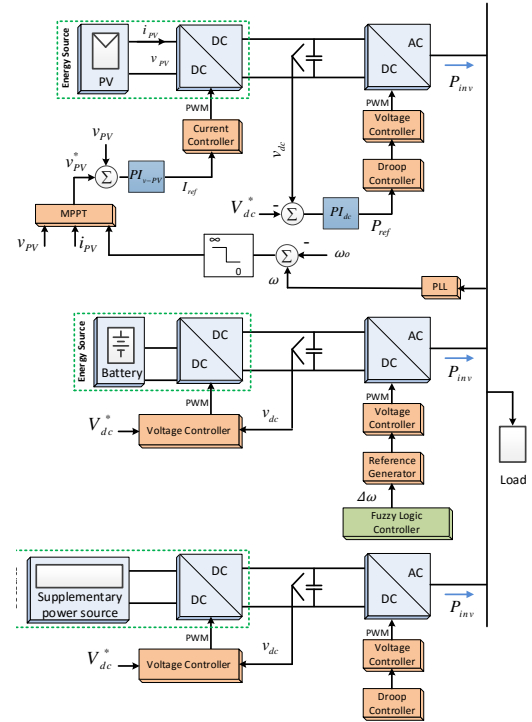

Fig.1: Microgrid Structure.

Similarly, if the PV power is less than the load, the battery will supply the shortage. However, the battery capacity is limited so if the SOC is approaching its maximum limit, PV power needs to be curtailed and if the SOC is reaching its lower limit, the auxiliary unit will need to supply power.

In a traditional droop control, the output frequency  $\omega$  and voltage amplitude  $V$  of any DC/AC inverter are given by Equations (1) and (2), respectively,

$$\omega = \omega_o - m(P - P^*) \quad (0)$$

$$V = V_o - n(Q - Q^*) \quad (0)$$

where  $\omega_o$ ,  $V_o$ ,  $m$ , and  $n$  are the nominal frequency, nominal voltage, frequency drooping coefficient, and voltage drooping coefficient, respectively.  $P$  and  $Q$  are the measured active and reactive powers and  $P^*$  and  $Q^*$  are active and reactive power demands, respectively.

The three DC/AC inverters in Fig. 1 have the same droop equation for reactive power as in (2). However, for active power, each unit has a different droop coefficient and power demand depending on its role. The battery unit forms the AC bus and it has to control the output voltage and frequency. The power delivered/absorbed by the battery depends on the PV power and load. To achieve this functionality, the droop coefficient  $m$  needs to be set to zero. In addition, in order to be able to curtail the PV power or to supplement power from the auxiliary unit, the bus frequency will vary by  $\Delta\omega$  which is

the output from the FLC. Thus, the output frequency of the battery unit is given by Equation (3).

$$\omega = \omega_o + \Delta\omega \quad (0)$$

The DC/AC inverter of the PV unit controls the DC link voltage by injecting more or less power into the AC bus. The droop control of the PV unit is given by Equation (4).

$$\omega = \omega_o - m_{pv}(P - P_{pv}^*) \quad (0)$$

where the power demand  $P_{pv}^*$  is the output of the proportional-integral (PI) controller that regulates the DC link voltage (see Fig. 1). In the steady state, the power demand  $P_{pv}^*$  equals the power generated by the DC/DC converter according to its MPPT algorithm. The PV unit acts as a power source injecting maximum power available from PV to the AC bus.

The auxiliary unit needs to provide power only when needed according to the bus frequency and its droop control is given by Equation (5).

$$\omega = \omega_o - m_{aux}P \quad (0)$$

Fig. 2 shows the frequency/power droop control for the three units based on (3) to (5). The zero droop coefficient of the battery unit makes it the master controller for the AC bus frequency. The bus frequency can be shifted up to curtail the PV power or shifted down to produce power from the auxiliary unit. For the PV unit, the output power  $P$  equals the demanded power  $P_{pv}^*$  when the bus frequency  $\omega$  equals the nominal frequency  $\omega_o$ . If the bus frequency is shifted down, the DC/AC inverter of the PV unit will deliver more power than that produced by the DC/DC converter which will cause the DC link voltage to drop. This drop will cause the PI controller of DC link voltage to reduce the power demand  $P_{pv}^*$  so that the DC/AC inverter delivers the same power produced by the DC/DC converter. However, if the bus frequency is shifted up, this will act as a message to the MPPT controller that the PV power needs to be curtailed. The MPPT controller measured the bus frequency using Phase Looked Loop (PLL) (see Fig. 1) and it will shift the maximum power point to a lower value by increasing the PV output voltage as illustrated in Fig. 3. The more rise in frequency the more curtailment in PV power. When the bus frequency is equal or higher than the nominal frequency  $\omega_o$ , the auxiliary unit will produce no power according to (5) and as shown in Fig. 2. If the bus frequency is shifted down, however, the auxiliary unit will start producing power and the more drop in frequency the more power produced. This way, power curtailment and supplement is controlled wirelessly through the bus frequency without any extra communication.

### 3 Proposed Fuzzy Logic Controller

The proposed FLC is responsible for varying the bus frequency and is shown in Fig. 4. It consists of two subsystems. The top subsystem is responsible for preventing the battery from overcharging, i.e., keeping the SOC below its

maximum limit. It also prevents the battery charging power from exceeding its limit. The inputs are  $\Delta SOC$  (the difference between the current SOC and its maximum value  $SOC_{max}^*$ ) and  $\Delta P_{charge}$  (the difference between the charging power and its maximum charging power value  $P_{charge\_max}^*$ ). The output is a positive shift in the frequency  $\Delta\omega_+$  to curtail the PV power. On the other hand, the bottom FLC subsystem is responsible for preventing the battery from over discharging, i.e., keeping the SOC above its minimum limit. It also prevents the battery discharging power from exceeding its limit. The inputs are  $\Delta SOC$  (the difference between the current SOC and its minimum limit  $SOC_{min}^*$ ) and  $\Delta P_{discharge}$  (the difference between the discharging power and its maximum discharging power value  $P_{discharge\_max}^*$ ). The output of the bottom FLC subsystem is a negative shift in the frequency  $\Delta\omega_-$  to cause the auxiliary unit to supplement power. The rules for the FLC are shown in Table 2 (top subsystem and Table 3 (bottom subsystem). The terms L, M and H denote low, medium and high membership functions, respectively. The frequency scaling values for top and bottom FLC subsystems shown in Fig. 4 are 0.12 and 0.064 respectively. They have been chosen to change the PV power from 0% to 100% in such a way that  $\Delta\omega_+ = 0$  means that PV will generate 100% of the MPPT value, while  $\Delta\omega_+ = 0.12$  curtails PV power to zero. Similarly,  $\Delta\omega_- = 0$  will not generate any power by the auxiliary unit, while  $\Delta\omega_- = 0.064$  will generate maximum power from the auxiliary unit.

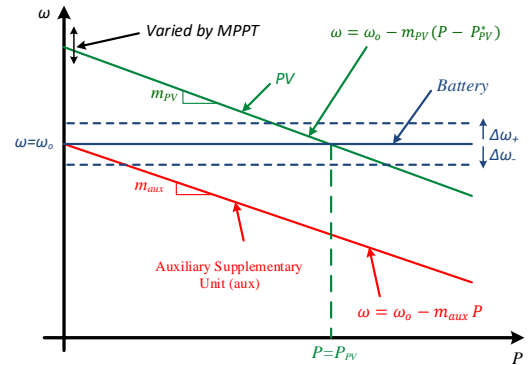

Fig. 2: Power – frequency droop control curves.

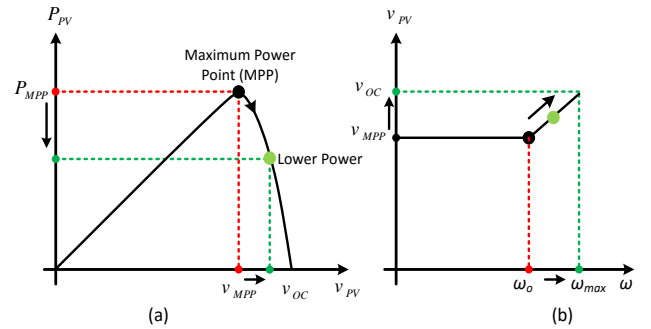

Fig. 3: PV MPP shifting operation: (a) PV power versus output voltage, (b) output voltage versus frequency.

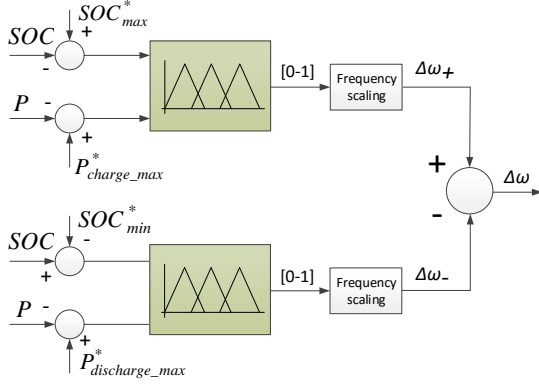

Fig. 4: Proposed fuzzy controller.

$\Delta\omega_+$		$\Delta P_{charge}$		
		L	M	H
$\Delta SOC$	L	H	H	H
	M	M	M	M
	H	L	L	L

Table 2: Rules of top FLC.

$\Delta\omega_-$		$\Delta P_{discharge}$		
		L	M	H
$\Delta SOC$	L	H	H	H
	M	H	M	M
	H	M	M	L

Table 3: Rules of bottom FLC.

Parameter	Symbol	Value
Maximum state of charge	$SOC_{max}^*$	95%
Minimum state of charge	$SOC_{min}^*$	40%
Maximum charging power	$P_{Charge\_max}^*$	1000W
Maximum discharging power	$P_{Discharge\_max}^*$	1000W
Nominal bus frequency	$\omega_o$	314rad/s
Nominal bus voltage	$V_o$	220V
Battery nominal voltage	$V_{DC}^*$	750V
Active power droop coefficients	$m_{pv}, m_{aux}$	0.9e-4 rad/s/W
Reactive power droop coefficients	$n$	0.9e-4 V/Var

Table 4: System parameters.

## 4 Simulation Results

A microgrid including the three power units and the proposed controllers has been built in Matlab/Simulink SimPowerSystem and Fuzzy Logic tool boxes. The system parameters used in the simulation are shown in Table 4.

For a high SOC case with initial value approaching the maximum limit of 95%, Fig. 5 shows the power output of PV, battery and auxiliary units along with load power. The

auxiliary unit was not running as the battery SOC was high with moderate load (500W). The FLC was deactivated before  $t = 3s$ . The battery charging power (500W) could cause overcharging. However, after activating the proposed FLC at  $t = 3s$ , the PV power was curtailed from 1000W to around 500W. The frequency was increased to reduce the PV's power generation. SOC was increasing although it was high prior to the FLC activation. However, it was stopped from increasing, kept constant and limited from exceeding its maximum limit after FLC activation. At  $t = 5s$ , the load became 1000W and the generation from the PV unit was proportional to the change in the frequency commanded by the FLC until the PV restored its full generation. The frequency was decreased to increase the PV's power production. The SOC was prevented from increasing beyond the maximum limit by curtailing the PV power but when the load increases the curtailment stopped so to make use of all available PV power.

Fig. 6 shows the power output of PV, battery and auxiliary units and load when the battery SOC was approaching its minimum limit of 40%. The FLC was deactivated before  $t = 3s$ . The battery was discharging and providing 600W since the load was 1600W and higher than the power generated from the PV which was 1000W. SOC was declining prior to the activation of the FLC (under-charging). The auxiliary unit was not running. However, at  $t = 3s$ , the FLC was activated and it decreased the bus frequency so the auxiliary unit reacted by generating 600W. The generated power was proportional to the frequency drop. The SOC was stopped from declining, kept constant and hence protected from undercharging. At  $t = 5s$ , the load dropped from 1600W to 100W, the available generation to be absorbed by the battery is now 1500W which exceeds the maximum charging power of 1000W. Thanks to FLC, the auxiliary unit stopped generating and the PV power supplied the load and the surplus power was absorbed by the battery to heal the low SOC. The charging power was limited to 900W instead of 1500W (if the auxiliary unit was left to generate). The FLC increased the bus frequency in order to stop the auxiliary unit from generating. The SOC started to increase making use of the available surplus power. As can be seen, the FLC prevented the battery SOC and power from exceeding their limits. During transient, however, the battery power exceeded the 1000W limit but only for a short period of time of 1 second.

In view of the above, the FLC controller used the full available PV power when required and curtailed it to prevent the battery from overcharging. In addition, it activated the auxiliary unit to support the battery and protect it from undercharging.

## 5 Conclusion

A controller based on fuzzy logic has been proposed for power management of islanded microgrids. The controller prevents the battery state of charge and charging/discharging power from exceeding their limits regardless of variations in



load and intermittent power of renewable energy sources. By varying the AC bus frequency and making use of local droop controllers, the power management controller was implemented without the need for any communication links between the microgrid units. Simulation results have been presented to validate the functionality of the proposed controller.

## Acknowledgements

The work is financially supported by the Government of Oman, which provides a PhD grant for Rashid Al Badwawi. Also, the work is supported by EPSRC-DST funded project: Reliable and Efficient System for Community Energy Solutions (RESCUES- EP/K03619X/1).

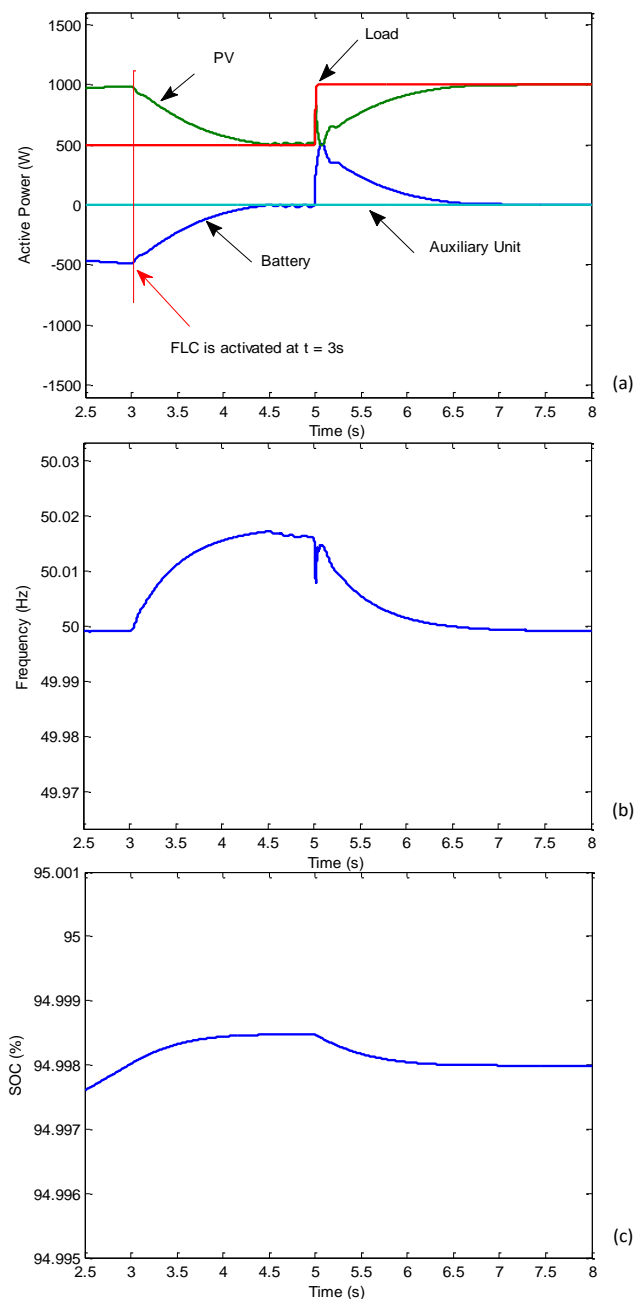

Fig. 5: Output response for 95% SOC case: (a) output power, (b) frequency (c) SOC.

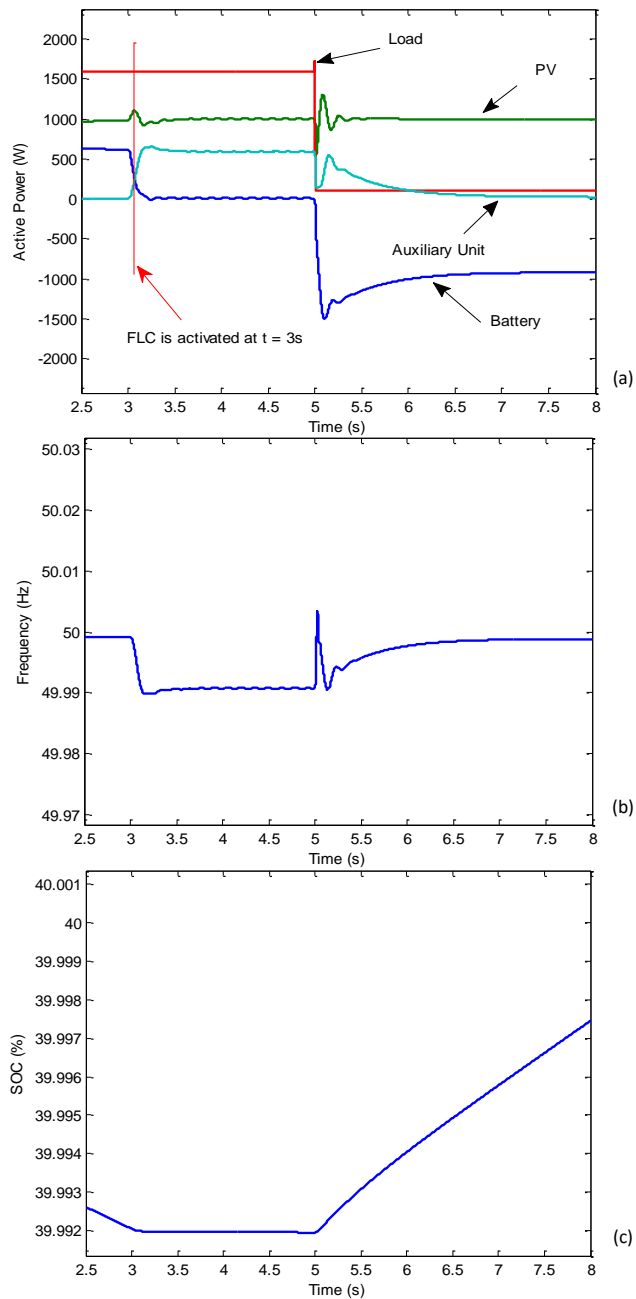

Fig. 6: Output responses for 40% SOC case: (a) output power, (b) Frequency, (c) SOC.

## References

- [1] N. Bigdeli, "Optimal management of hybrid PV / fuel cell / battery power system: A comparison of optimal hybrid approaches", *Renew. Sustain. Energy Rev.*, vol. 42, pp. 377–393, (2015).
- [2] M. Cheikh, C. Larbes, G. Tchoketch, A. Zerguerras. "Maximum power point tracking using a fuzzy logic control scheme", *Rev. des energies ...*, vol. 10, pp. 387–395, (2007).
- [3] T. ESRAM, P. L. Chapman, "Comparison of photovoltaic array maximum power point tracking techniques", *IEEE Trans. Energy Convers.*, vol. 22, no. 2, pp. 439–449, (2007).
- [4] B. Hamed, M. El-Moghany. "Fuzzy controller design using FPGA for photovoltaic maximum power point tracking", *J. Adv. Res. Artif. Intell.*, vol. 1, no. 3, pp. 14–21, (2012).
- [5] G. Balasubramanian, S. Singaravelu. "Fuzzy logic based controller for a stand-alone hybrid generation system using wind and photovoltaic energy", *Int. J. Adv. Eng. Technol. (IJAET)*, vol. 3, no. 2, pp. 668–679, (2012).
- [6] M. S. Bisht, Sathans. "Fuzzy based intelligent frequency control strategy in standalone hybrid AC microgrid", *2014 IEEE Conference on Control Applications (CCA)*, pp. 873–878, (2014).
- [7] M. Marzband, A. Sumper, O. Gomis-Bellmunt, P. Pezzini, M. Chindris. "Frequency control of isolated wind and diesel hybrid microgrid power system by using fuzzy logic controllers and PID controllers", *Proceeding of the 11<sup>th</sup> International Conference on Electrical Power Quality and Utilisation, EPQU*, pp. 114–119, (2011).
- [8] M.-W. Cheng, S.-M. Wang, Y.-S. Lee, S.-H. Hsiao. "Fuzzy controlled fast charging system for lithium-ion batteries", *International Conference on Power Electronics and Drive Systems (PEDS)*, pp. 1498–1503, (2009).
- [9] A. L. A Mu-ti, C. Qin, T. E. Y Bu-la-yin, L. Jian-chun. "Application of fuzzy control for the energy storage system in improving wind power prediction accuracy", *Am. J. Energy Res.*, vol. 1, no. 3, pp. 54–58, (2013).
- [10] R. AlBadwawi, M. Abusara, T. Mallick. "A review of hybrid solar PV and wind energy system", *Smart Sci.*, vol. 3, no. 3, pp. 127–138, (2015).
- [11] L. Suganthi, S. Iniyar, A. A. Samuel. "Applications of fuzzy logic in renewable energy systems – A review", *Renew. Sustain. Energy Rev.*, vol. 48, pp. 585–607, (2015).
- [12] C. Ben Salah, M. Ouali. "Energy management of a hybrid photovoltaic system", *Int. J. Energy Res.*, vol. 36, pp. 130–138, (2012).
- [13] T. P. Kumar, Y. Chandrashekar, N. Subrahmanyam, M. Sydulu. "Control strategies of a fuzzy controlled grid connected hybrid PV / PEMFC / battery distributed generation system", *2015 IEEE Power and Energy Conference at Illinois (PECI)*, pp. 1–6, (2015).
- [14] Y. Chen, Y. Wu, C. Song. "Design and implementation of energy management system with fuzzy control for DC micro-grid systems", *IEEE Trans. Power Electron.*, vol. 28, no. 4, pp. 1563–1570, (2012).
- [15] D. Arcos-Aviles, F. Guinjoan, J. Barricarte, L. Marroyo, P. Sanchis, H. Valderrama. "Battery management fuzzy control for a grid-tied microgrid with renewable generation", *IECON 2012 - 38th Annu. Conf. IEEE Ind. Electron. Soc.*, pp. 5607–5612, (2012).
- [16] A. Lal, R. Kumar, U. Mehta. "Energy dispatch fuzzy model in hybrid power system", *Int. Energy J.*, vol. 14, pp. 133–142, (2014).
- [17] X. Li, D. Hui, L. Wu, X. Lai. "Control strategy of battery state of charge for wind / battery hybrid power system", *IEEE Int. Symp. Ind. Electron.*, pp. 2723–2726, (2010).
- [18] Y. Yin, X. Luo, S. Guo, Z. Zhou, J. Wang. "A battery charging control strategy for renewable energy generation systems", *Proceedings of the World Congress on Engineering (WCE 2008)*, vol. I, pp. 356–361, (2008).
- [19] N. L. Diaz, T. Dragi, J. C. Vasquez, J. M. Guerrero, "Fuzzy-logic-based gain-scheduling control for state-of-charge balance of distributed energy storage systems for DC microgrids", *Appl. Power Electron. Conf. Expo. (APEC), 2014 Twenty-Ninth Annu. IEEE*, pp. 2171–2176, (2014).
- [20] D. Wu, F. Tang, T. Dragicevic, J. C. Vasquez, J. M. Guerrero, "Autonomous active power control for islanded AC microgrids with photovoltaic generation and energy storage system", *IEEE Trans. Energy Convers.*, vol. 29, no. 4, pp. 882–892, (2014).
- [21] W. R. Issa, M. A. Abusara, S. M. Sharkh. "Control of transient power during unintentional islanding of microgrids", *IEEE Trans. Power Electron.*, vol. 30, no. 8, pp. 4573–4584, (2015).