

The dynamic stiffening effects of non-structural partitions in building floors

Dr C J Middleton, Professor A Pavic
Department of Civil & Structural Engineering, University of Sheffield,
Mappin Street, Sheffield, United Kingdom, S1 3JD
C.J.Middleton@Sheffield.ac.uk

ABSTRACT

It is commonly known that full-height non-structural partitions of a fitted out floor structure affect its dynamic properties, with increase in floor mass and modal damping being commonly quoted in floor design guidelines. As a consequence, it is generally accepted that the non-structural elements usually reduce the response of floors to walking excitation. There is very little understanding of the effects of full-height partitions on the stiffness of building floors and this effect is generally not taken into account in floor design guidelines.

This paper is therefore focused on establishing experimentally the effects of full-height non-structural partitions on dynamic stiffness of a full-scale real-life composite building floor. Modal testing data are presented for three construction phases of the floor: from a completely bare floor via partially to fully-fitted floor. The effects of the partitions are shown by comparing the measured frequency response functions (FRFs) at the same location for different construction phases and the estimated key modal properties of the floor corresponding to these phases. This kind of multi-phase measurements on a real-life floor structure during construction is very rare due to its logistical complexity and long-time required to gather data through all of the phases.

It is shown that the partitions significantly affect measured FRFs by increasing damping, and in particular, floor stiffness. It is also shown that the mode shapes are changed by the partitions. The magnitude of the changes is quantified experimentally which is one of the first attempts to do this on a real-life floor structure using high-quality FRF measurements.

Keywords: partitions, experimental, floor, stiffness, damping

Introduction

It is commonly known that non-structural elements change the dynamic characteristics of building floors. This phenomenon became increasingly apparent with advances in technology. Offices that were traditionally paper based became paperless 'electronic offices'. Heavy filing cabinets that were filled with paper could now be stored on a single hard disk. The removal of the filing cabinets significantly reduced the additional mass on the floor. This was coupled with the removal of partitions to allow more people to fit within the same space. Often, once a traditional paper office became an electronic paperless and open plan office there would be complaints about excessive vibration [1] which was due to the removal of the non-structural elements.

The reduction in mass due to the removal of non-structural elements is easily calculable, but it is generally not enough to increase the response of the floor to unserviceable levels. The removal of the non-structural partitions also significantly reduced the amount of damping in the system. From experience, there is a belief that the removal of non-structural full-height partitions reduces the damping more than any other non-structural elements.

There is little published literature concerning the effects of non-structural partitions. Generally, when the effects of non-structural partitions on floor vibration is discussed it is a passing mention, and just in relation to the variation in damping,

suggesting that they may add up to 5% damping ratio for each mode of vibration [1] [2] [3] [4] [5], . This is the approach of many of the design guides [6] [7] [8]. The effect full-height non-structural partitions on the floor stiffness is often ignored.

However, there are a number of key publications and research projects that have investigated non-structural partitions that give a good base to start future work. One of the earliest in-depth investigations was by Pernica in 1987 [9]. The investigation measured the response of a long span school floor in various stages of construction and estimated modal properties from heel strikes. He showed that there was a significant increase in damping and frequency for the same modes in different construction phases. Unfortunately the force was not measured so it was not possible to quantify the change in response or FRFs.

It took 22 years for another similar study of this kind conducted on a real-life floor to be reported as in 2009 Miskovic et al. [10] compared the vibration behaviour of two nominally identical floors with different partition layouts. In this case, any significant change in dynamic properties would be due to the different fit out of the floor. It was found that the partitions not only increased the frequency and damping of the floor, they also affected the mode shapes. In addition, the estimated modes were complex, suggesting that partitions add non-linear behaviour to the floor or non-proportional damping.

Other studies have indirectly shown that partitions effect the dynamic properties of a floor by comparing experimental modal properties with modal properties calculated using finite element analysis [10] [11]. In these studies an initial finite element (FE) model, with no partitions, is created and compared with the experimentally determined modal properties of the physical floor with partitions. The FE model is shown to underestimate the frequencies of the modes. If partitions are added to the model, and after a process of model updating, a good match of experimental and analytical modal properties can be achieved. This includes a better natural frequency correlation and improved mode shape correlation. However, modelling the partitions is still challenging due to non-structural connections between the partitions and the floors. The outcomes of the studies are case specific and currently there is not a modelling technique that is suitable for all cases.

The study of non-structural partitions has also featured in a number of PhD theses [12] [13]. Generally these studies of limited usefulness for practical applications, but a number of conclusions are still valid. They all find that the partitions increase the stiffness of the floor and add damping. They also continue to consider how the alignment of the partition to the mode shapes affects the dynamic properties. It is shown that if the partitions lie along a steep gradient in the mode shape, for equal partitions lengths, they will affect the dynamic properties more.

This study compares the experimentally determined dynamic properties of a steel-concrete prototype composite floor in various construction phases, which include first without and then with partitions. Firstly, a description of the floor structure is presented. This is followed by the description of experimental measurements which enabled direct comparisons between the phases via measured FRFs and estimated modal properties. Based on these, clear conclusions have been drawn and are presented at the end of the paper.

Structural description of the prototype floor

The structure that was tested is a steel framed four floor (inclusive of the ground floor) supporting a high quality office environment and possible use of optical microscopes. It was required for the floor to have good vibration performance, somewhere between the criteria for hospitals and offices. This investigation focuses on one of the four floors in the building.

The floor-to-floor height varies slightly with each level due to functional requirements. However, assuming an approximate floor-to-floor height of 4 m would seem to be appropriate. For each floor, the main floor area comprises a 150 mm deep steel-concrete composite section using Holorib galvanised steel deck profile with a 1.2 mm gauge, as show in Fig. 1.

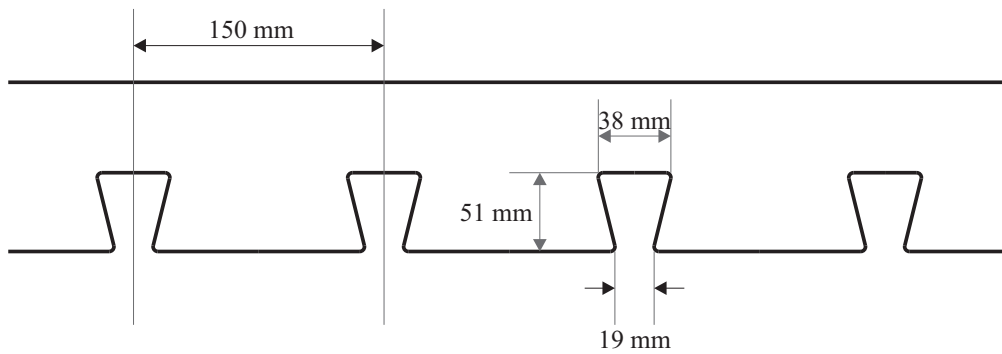
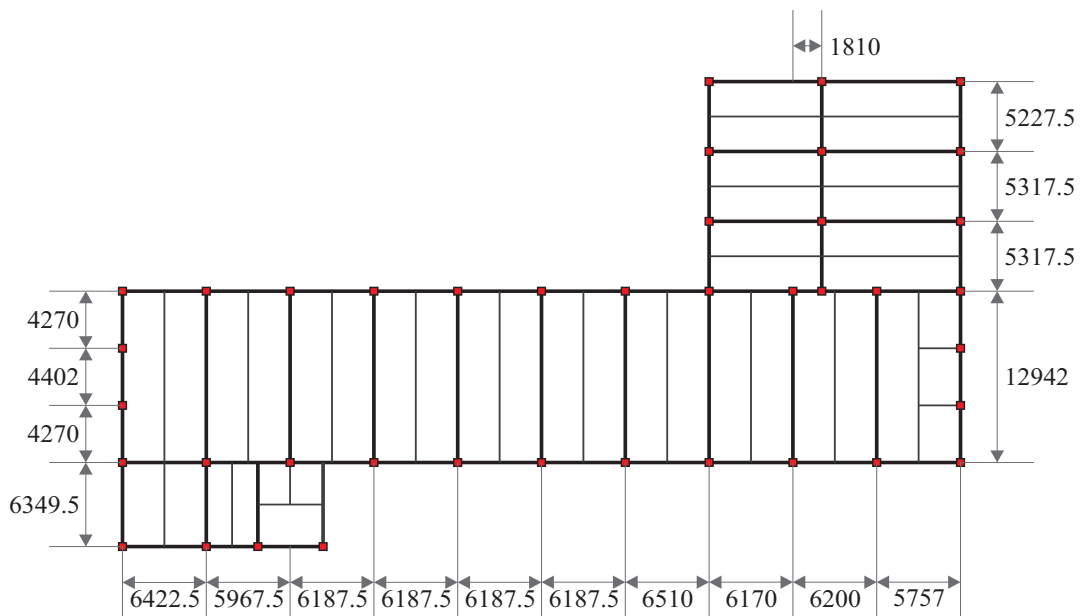

Fig. 1: 150mm deep Holorib section used in the prototype composite floor

The main floor area, shown in Fig. 2, is made up of ten bays with an approximate width and length of 6.2 m and 12.9 m respectively, with a secondary beam running in the long direction of the bays.



* All dimensions in mm

Fig. 2: Plan of the prototype composite floor, the thick line represents primary beams and the thin line represents secondary beams

Two types of full height partitions were constructed on all of the floors: plasterboard stud partitions as shown in Fig. 3 (left) and block partitions as shown in the right plot of Fig. 3 (right).



Fig. 3: Plasterboard stud partitions (left) and block wall partitions (right) used in the prototype composite floor from phase 2

There were a large number of partitions on each floor, which included creating a corridor through the middle and along the main part of the floor which is clearly shown in Fig. 4.

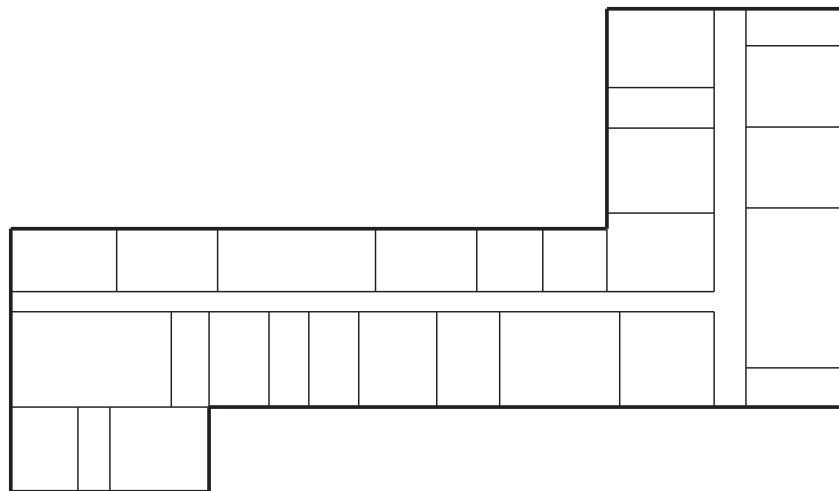

Fig. 4: Partition layout for floor 3 of the prototype composite floor

Experimental measurements

The floors were tested during three phases of construction and fit out. This allowed for direct comparisons of the dynamic properties of the floor with different conditions. The three phases were:

Phase 1: Bare structure; only columns, beams and floor. The outside cladding of the building had not been added, example photos are shown in Fig. 5.

Phase 2: The outside cladding of the building had now been added. Most partitions and services had been added to floor 3. There had been a small amount of fitting out on floor 4, example photos are shown in Fig. 3.

Phase 3: The building had now been completely fitted out. This includes non-structural partitions, services, fixtures and fittings (such as doors, carpets, etc.) and furniture. The building is almost ready for opening, example photos are shown in Fig. 6.

For each structure and phase, EMA was conducted using multiple shakers and multiple accelerometers, allowing for MIMO analysis. Using multiple shakers minimised the risks of modes being missed by having excitation point on mode shape nodes

and it also increases the amount of energy put into the structure which is beneficial for large structures, or stiff heavily damped structures. Typical FRF point mobility measurement is shown in Fig. 5 (left).



Fig. 5: The left photo shows a shaker and accelerometer that was used in phase 1 and the right plot shows the bare structure of phase 1



Fig. 6: The left photo shows a shaker used in Phase 3 and the right photo shows one of the largest partitioned out rooms from Phase 3

The shakers used were four APS Dynamics electro-dynamic shakers and they applied uncorrelated random excitation to the floor with the force measured indirectly using an accelerometer mounted on the moving mass of the shaker. To measure the response, 16 Endevco 7754-1000 piezo-electric accelerometers were used. The responses were sampled at 51.2 Hz and transfer functions recorded using a Data Physics DP730 24-bit spectrum analyser. The transfer functions were created with 40 averages by analysing the time history data using a 50 s Hanning windows and a 75% overlap, which gave a frequency resolution of 0.02 Hz. Five ‘swipes’ across all test points were required to capture the whole floor area, comprising of 80 test points. The shaker forces were used as stationary reference points which allowed the mode shapes to be spliced together. Curve-fitting was performed in ME’Scope software.

The floor in each phase was tested with a nominally identical methodology, using the same equipment, test grid and analysis procedure. The test grid used is shown in Fig. 7 with four shakers at test points (TPs) 13, 43, 61 and 73, which are also the reference points.

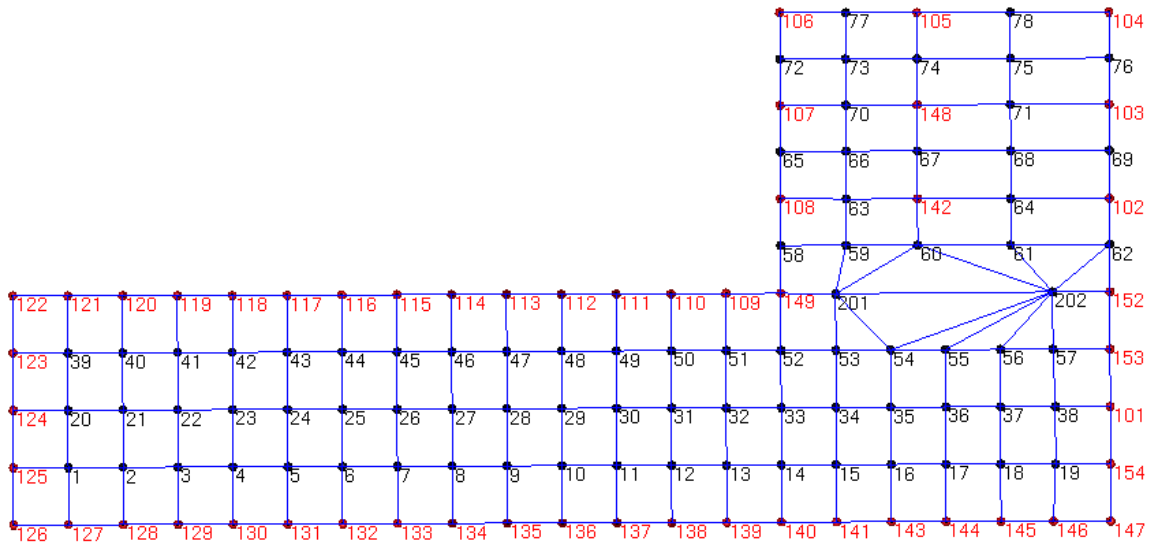

Fig. 7: Test grid for the prototype composite floor

The addition of the partitions and fitting out of the structure significantly change the dynamic properties of the floor, which is highlighted in Fig. 8. The left plot of Fig. 8 shows the point acceleration FRFs for TP 13, which is expected to give clean FRFs. It is clear that there are obvious peaks in the FRF for Phase 1, which represents a good number of identifiable modes, the first large peak being approximately 5.8 Hz, although there is a smaller peak at approximately 5.2 Hz. For each subsequent phase the amplitude of the FRF reduce considerably, as do the sharpness, and the width increases. For phase 2 and 3 the first identifiable peaks are approximately 6 Hz and 6.4 Hz respectively (although hard to see in the plot), which indicates significant stiffening of the structure. For Phase 2 and 3 the peaks are much less clear and more difficult to identify. This indicates that partitions completely changed the structural system of the bare floor and that there is for sure significantly more damping within the structure.

The right plot in Fig. 8 shows the dynamic point stiffness at TP 13. For low frequencies before the first resonances it is a good estimate of the static stiffness. In each phase the point stiffness has increased by approximately 0.5×10^8 N/m, which is a significant increase in stiffness, with the point stiffness of phase 3 being approximately 4 to 5 times stiffer than in phase 1.

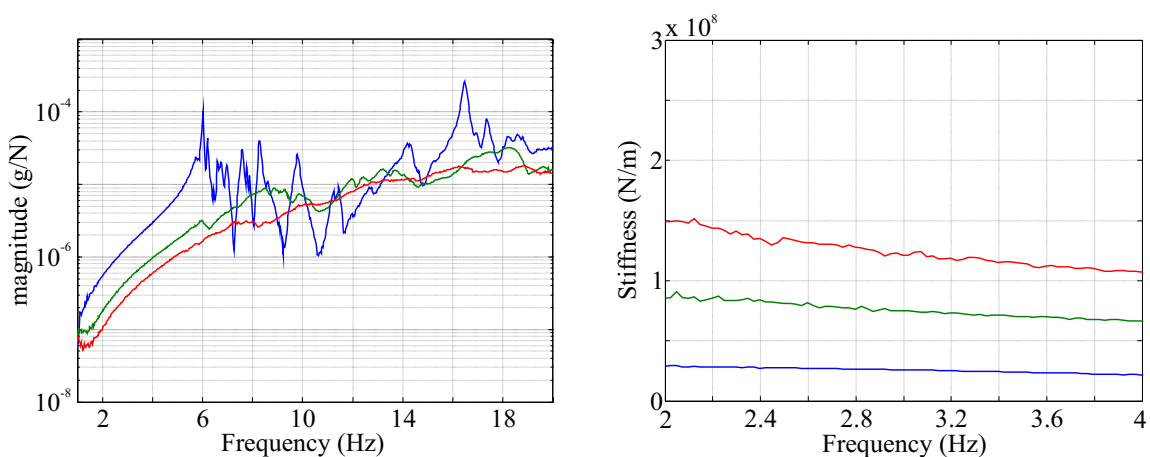

Fig. 8: Point acceleration FRFs (left) and dynamic stiffness (right) at TP 13 for phase 1, 2 and 3; the blue, green and red lines represent phase 1, 2 and 3 respectively

It is clearly both the increase in damping and stiffness properties that affected the magnitude and shape of the FRFs so considerably.

Due to the large changes in stiffness and damping it is difficult to directly compare modal properties between phases as they are, strictly speaking, no longer the same mode. In addition, as the peaks become harder to identify it becomes more difficult to curve fit the FRFs to obtain accurate modal properties. Moreover, with the partitioned layouts in phases 2 and 3, it was often the case that the curve fitted modes were complex, in which case, the visual appearance of the mode shapes depend on the realisation angle used. The complex modes also indicate that the structure may be becoming increasingly non-linear or have non-proportional damping. To aid in the visualisation of the modal complexity, complexity plots are shown in Fig. 10.

However, there is still merit in comparing the first couple of modes of vibration between phases 1 and 3, which can give an indication of the overall stiffness of the structure. The first two mode shapes and frequencies for the tested floor are shown for phases 1 and 3 in Fig. 9. The natural frequencies have increased by approximately 10% to 15%, indicating an increase in modal stiffness which offset increases in the mass of the non-structural elements used to fit out the floor. If the fundamental mode shape is considered there is a 'plateau' introduced in the Phase 3 fundamental mode shape, which likely indicates an area on the floor developing increased stiffness. When considering the second mode of vibration, the length of the mode reduces with phase 3, what 'plateaus' introduced at either end of the building, again indicating likely sources of floor stiffening.

If the partition layout from Fig. 4 is considered, the corridor running down the main length of the floor area results in two lines of partitions near the antinodes of the modes. This is likely to be the cause of the significant stiffening within the structure. In addition, there is a higher density of partitions near the plateau shown in the fundamental mode of phase 3 (Fig. 9), which explains the localised stiffening in this area. Hence, there is a perfectly rational explanation for the modal behaviour of the partitioned layout.

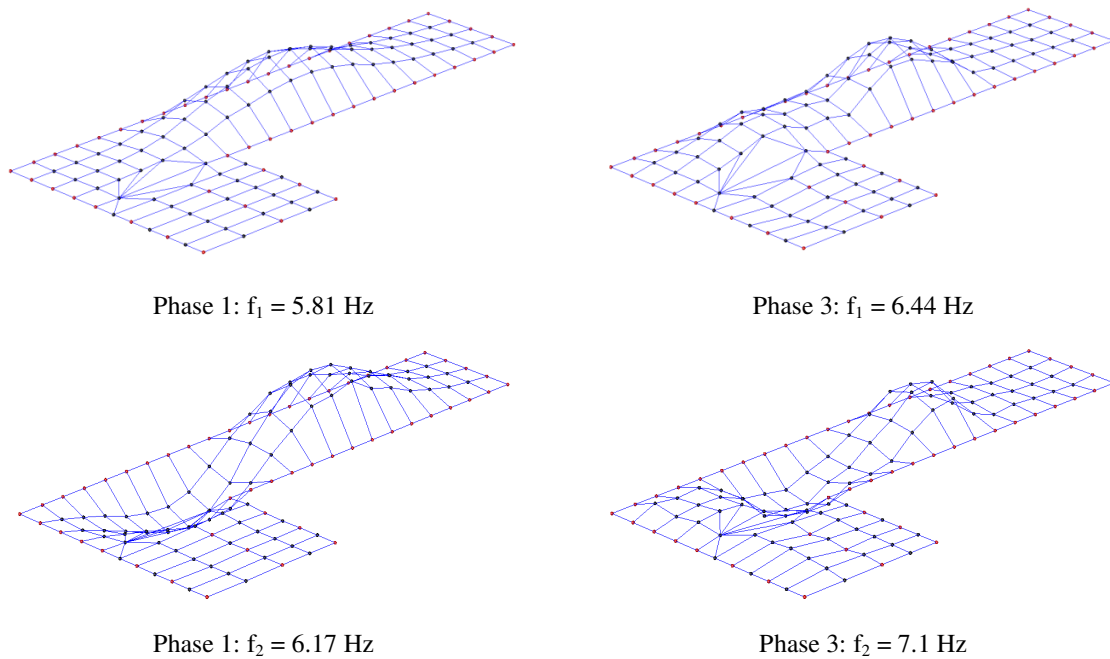

Fig. 9: First two mode shapes and frequencies for floor 3 for phase 1 and 3

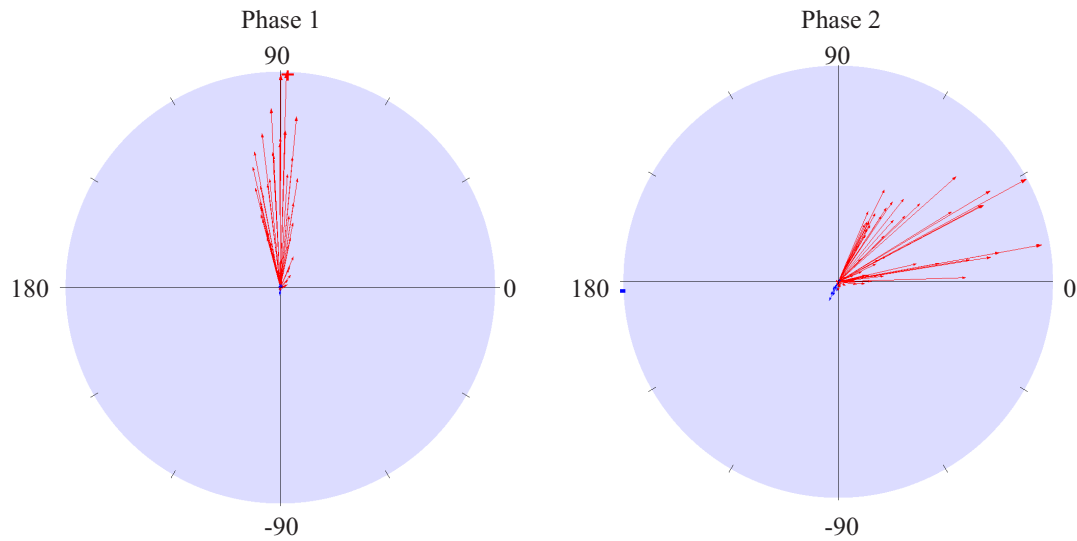

Fig. 10: Complexity plots for the fundamental mode shapes for floor 3 for phase 1 and 3

Summary and conclusions

It was shown that full-height non-structural partitions can significantly affect the dynamic properties of floors. This was demonstrated experimentally by performing EMA on a structure in various stages of construction, which included with and without partitions. Comparisons of modal properties and FRFs were conducted.

With partitions added to the floor, the first two modes of vibration increased in frequency which implies there is an overall increase in stiffness. The two modes of vibration visually appear to be similar for tests with and without partitions, although the shape does change slightly. This indicates that the partitions also have a local stiffening effect. The modes shapes for the structure with partitions were also more complex, which is usually caused by non-linearities or non-proportional damping.

When considering the changes in FRFs with the construction phases it was shown that partitions had a positive shift in FRF peak frequencies, also suggesting an overall increase in stiffness. In addition, the magnitude of the peaks reduced and the width increased, this is due to an increase in damping. From the FRFs it was also possible to determine the point stiffness at the shaker location. The addition of the partitions increased the point stiffness by four to five times.

The partitions in this study had a significant stiffening effect on the floor with localised and global stiffness increases. These stiffening effects increase natural frequencies and alter mode shapes, assuming partitions only add damping is not appropriate. It is likely that the significant effect of the partitions is due to the partition layout.

The presented EMA results provide an excellent basis for a future FE modelling exercise for all phases tested which aim would be to develop methodology for FE modelling of partitions.

References

- [1] C. M. Hewitt and T. M. Murray, "Office fit-out and floor vibrations," *Modern steel construction*, pp. 35-38, April 2001.
- [2] D. E. Allen and G. Pernica, Control of floor vibration, Allen, David E., and G. Pernica. Control of floor vibration. Institute for research in construction, National research council of Canada, 1998.
- [3] L. M. Hanagan, "Floor vibration serviceability: Tips and tools for negotiating a successful design," *Modern steel construction*, vol. 43, no. 4, pp. 39-48, 2003.

- [4] T. M. Murray, "Design to prevent floor vibrations," *Engineering journal*, vol. 12, no. 3, 1975.
- [5] T. M. Murray, "Tips for designers of office buildings," *Structure*, pp. 26-30, 2000.
- [6] A. Smith, S. J. Hicks and P. J. Devine, *Design of floors for vibration - A new approach* (revised edition), London: The steel construction institute, 2009.
- [7] M. R. Willford and P. Young, *A design guide for footfall induced vibration of structures*, The concrete centre, 2006.
- [8] T. M. Murray, D. E. Allen and E. E. Ungar, *Floor vibrations due to human activity*, American institute of steel construction, 2003.
- [9] G. Pernica, "Effect of architectural components on the dynamic properties of a long-span floor system," *Canadian journal of civil engineering*, vol. 14, no. 4, pp. 461-467, 1987.
- [10] Z. Miskovic, A. Pavic and P. Reynolds, "Effects of full-height nonstructural partitions on modal properties of two nominally identical building floors," *Canadian journal of civil engineering*, vol. 36, no. 7, pp. 1121-1132, 2009.
- [11] R. Cantieni, S. Pietrzko and Y. Deger, "Modal investigation of an office building floor," in *16th international modal analysis conference*, 1998.
- [12] S. Falati, *he contribution of non structural components to the overall dynamic behaviour of concrete floor slabs*, Oxford: University of Oxford, 1999.
- [13] F. Ljunggren, *Floor vibration - Dynamic properties and subjective perception*, Lulea: Lulea University of Technology, 2006.