



**UNIVERSITI PUTRA MALAYSIA**

**DEVELOPMENT OF PC-BASED MULTI-CHANNEL  
MEASUREMENT UNIT**

**ABDU IDRIS OMER**

**FK 1997 11**

**DEVELOPMENT OF PC-BASED MULTI-CHANNEL  
MEASUREMENT UNIT**

**By**

**ABDU IDRIS OMER**

**Thesis Submitted in Fulfillment of the Requirements for  
the Degree of Master of Science in the  
Faculty of Engineering  
Universiti Putra Malaysia**

**October 1997**



## ACKNOWLEDGMENTS

I would like to express my appreciation to the chairman of my supervisory committee Dr. Bambang Sunaryo Suparjo Head Department of Electrical and Electronic Engineering, UPM who patiently advised and assisted me to finish my thesis at the optimum period and I deeply indebted to him for his useful suggestions and encouragement. Dr. Bambang had helped me find a graduate assistantship for more than a year. Also I would like to thank Dr. Junainah Abd. Hamid whom supervision had really supported and encouraged me to continue in my project. My appreciation is extended to Mr. Yasin the Technician in the Electronic laboratory, UPM for his frequently technical assistantship and considerable help in my project.

Thanks to my parents who indeed supported and taught me the significant meaning of patience and accuracy in dealing with hard work and facing difficulties and obstacles since I was in the primary school



# TABLE OF CONTENTS

	Page
ACKNOWLEDGMENTS .....	ii
LIST OF TABLES .....	vii
LIST OF FIGURES .....	viii
LIST OF ABBREVIATIONS .....	ix
ABSTRACT .....	xi
ABSTRAK .....	xii

## CHAPTER

<b>I INTRODUCTION .....</b>	<b>1</b>
Overview of the Microcomputer Applications.....	1
Microcomputer Structure .....	3
Central Processing Unit (CPU) .....	3
Address Bus .....	4
Data Bus .....	4
Control Bus .....	5
Memory .....	5
Input/Output .....	5
Recent Development of Measuring Instruments .....	6
Permanent-Magnet Moving Coil .....	6
Volt-Ohm-Millimetre .....	7
Cathode-Ray Oscilloscopes .....	7
Graphic Recording Instrument .....	7
32-Channel Isolated Temperature Measurement Board .....	8
8-Channel Analogue Output Board.....	8
Principles of Biosensors Development .....	9
Organisation of the Thesis .....	9
<b>II LITERATURE REVIEW .....</b>	<b>11</b>
Microcomputer-Based Instrument.....	11
Introduction .....	11
Overview of Smart-Scale Operation .....	11
Benefits of Using Microcomputer-Based Scale .....	14
Semiconductor Temperature Sensors .....	15
Thermocouples .....	19



	RTDs and Thermistors .....	20
	Strain Gauges and Load Cells.....	20
	Linear Variable Differential Transformers .....	20
	Flow Sensors .....	21
	Interfacing to Relays .....	21
	Interfacing Displays to Microcomputers .....	22
	Incremental Encoders .....	22
	Flow Injection Analysis (FIA) .....	23
	An Instrument for Determining Hydrogen Peroxide Enzyme .....	24
	Theoretical Measurement .....	25
	Development of I/O Card .....	26
<b>III</b>	<b>THE DESIGN APPROACH OF PC-BASED MULTI-CHANNEL MEASUREMENT UNIT .....</b>	<b>28</b>
	Introduction .....	28
	Multi-Channel PC-Based Current Measurement Board Design Techniques .....	29
	The I/O Port Interfacing Techniques .....	33
	Port Addressing .....	33
	I/O Port Address Map .....	33
	I/O Port Address Decoding Techniques .....	33
	Operation .....	37
	The Development of the Application Program System .....	42
	Overview on Assembly Language .....	42
	The Application Program System Description .....	42
	The BIOS .....	46
	DOS Interrupt 21H .....	48
	Procedures and Macros Related to the Floating Point Number Mathematical Operations .....	49
	Procedures for Converting Floating Point Number to Other Formats .....	52
<b>IV</b>	<b>RESULTS .....</b>	<b>54</b>
	Operational Amplifier .....	54
	Open-Loop Gain of 741 Operational Amplifier Versus Frequency Response .....	54
	The Instrumentation Amplifier Characteristics and Results.....	56
	Active Low-Pass Filter .....	58
	The Actual and Expected Output Values of the A/D Converter Results .....	60



	The Evaluation of the Application Program System	63
	General Comment	64
<b>V</b>	<b>CONCLUSION</b>	65
	Significant Findings	65
	The Advantages of Using the Microcomputer as a Measuring System	66
	Limitations of Using the Assembly Language in Application Systems	66
	General Rules and Recommendations for the I/O Card Design	68
	System-bus Loading and Driving Capabilities	68
	Capacitive Bus Loading	68



<b>APPENDIX A</b>	71
<b>APPENDIX B</b>	79
<b>APPENDIX C</b>	83
<b>REFERENCES</b>	99
<b>VITA</b>	102



## LIST OF TABLES

Table	Page
1 Input voltage and the Corresponding Output Voltage of a Circuit Design Including an Instrumentation Amplifier and a Low-Pass Filter.....	61
2 Digital Output Data from ADC to Analogue Signals .....	62
3 New Set of Analogue Input Signals with the Corresponding Digital Outputs .....	62
4 Reading Signal voltage Using the Meter and the I/O card .....	63
5 Capacitance Values for Low-Pass Butterworth Active Filter Designs .....	72





## LIST OF FIGURES

Figure		Page
1	Block Diagram of a Simple Microcomputer	6
2	Block Diagram of Microcomputer-Based Smart Scale	12
3	Circuit Diagram for Load-Cell Interface Circuitry and A/D Converter for Smart Scale	13
4	Flowchart for Smart-Scale Program	16
5	Light-Controller Relay Circuit Using a photocell	18
6	Photo-Diode Circuit to Measure Light Intensity	18
7	Linear Encoder	23
8	pH measurement circuit	25
9	Block Diagram of the 2-Channel Isolated Current Measurement Board	30
10	Analogue Switch TL 604	31
11	Baseboard I/O Port Address Usage	34
12	Card Slot I/O Port Address Usage	35
13	The I/O Interfacing Card Design	36
14	Basic Relationship of A/D Converter	40
15	A/D Converter Errors	41
16	A Combination of Hexadecimal Numbers to Access Ports 180 H, 181 H, 182 H, and 183 H	45
17	Flow Chart of Data Reading Program from a Sensor	46
18	Open-Loop Op-Amp 741 Circuit	55
19	Op-Amp Connected in Differential Mode	57
20	Common-Rejection Ratio as a Function of Frequency	58
21	Single-Pole Active Low-Pass Filter	59
22	Typical Response Curve of Low-Pass Filter	59
23	Instrumentation Amplifier and a Low-Pass Filter	60
24	Two different Measurement Systems Results	64
25	Instrumentation Amplifier	72
26	Low-Pass Filter Design Steps	73
27	0804 ADC A/D Converter	74
28	Mode Control Word Format for 8255 PPI	75
29	Addressing Scheme for the PPI	76
30	Analogue to Digital Converter Signals and Timing diagram	77
31	8255 PPI Pin Connection	78
32	PC Systems Family by Major Architecture Enhancements	80



## LIST OF ABBREVIATIONS

PPI	- Programmable Peripheral Interfacing
EPROM	- Erasable Programmable Read Only memory
RD	- Read
WR	- Write
MREQ	- Memory Request
MREAD	- Memory Request
MWRITE	- Memory Write
IOWRITE	- Input/Output Write
IOREAD	- Input/Output Read
OE	- Output Enable
NMI	- Nonmaskable Interrupt
SS	- Stack Segment
SP	- Stack Pointer
BCD	- Binary Coded Decimal
MSD	- Most Significant Digit
MSB	- Most Significant Bit
V <sub>cc</sub>	- Supply Voltage
MHz	- Mega Hertz
DMA	- Direct Memory Access
OSC	- Oscillator
ALE	- Address Latch Enable
CH CK	- Channel Check
CH RDY	- Channel Ready
IRQ	- Interrupt Request
DRQ	- Direct Memory Access Request
DACK	- Direct Memory Access Acknowledge
TC	- Terminal Count
DC	- Direct Current
RMS	- Root Mean Square
T	- Absolute Temperature
V <sub>n</sub>	- Device Noise Voltage
FET	- Field Effect Transistor
dB	- Decibel
FS	- Full Scale
V	- Volt
L	- Inductor
C	- Capacitor
SC	- Start Conversion
EOC	- End of Conversion
LSB	- Least Significant Bit



CPU	- Central Processing Unit
IC	- Integrated Circuit
A1.....An	- Address Lines
D0.....Dn	- Data Lines
CS	- Device-Selection Signal
MASM	- Microsoft Macro Assembler
ROM	- Read Only Memory
RAM	- Read and Write Memory
ES	- Extra Segment
IBM	- International Business Machines
DOS	- Disk Operating System
DS	- Data Segment
ACK	- Acknowledge
EQU	- Equate
ASCII	- American Standard Code for Information Interchange
FP	- Floating Point
FPOI	- Floating Point to Integer Conversion



Abstract of the thesis submitted to the Senate of Universiti Putra Malaysia in fulfilment of the requirements for the degree of Master of Science.

## **DEVELOPMENT OF PC-BASED MULTI CHANNEL MEASUREMENT UNIT**

By

**Abdu Idris Omer**

October 1997

Chairman: Dr. Bambang Sunaryo Suparjo

Faculty : Engineering

Nowadays the microcomputer has been involved in a variety of applications. These applications range from a simple ON/OFF operation to intelligent data acquisition, signal processing and control in individual automation applications. Moreover it can be utilised in monitoring different physical and electrical quantities. This study was mainly concerned with the design of 2-channel isolated current measurement board. The board can be plugged into one of the input/output (I/O) slots in the IBM/PC/AT or compatibles. Signal from enzyme electrodes were used in the analysis to monitor the oxygen consumption or the production of hydrogen peroxide that represented the input current to the board. Each channel was selected using a software.



Abstrak tesis yang dikemukakan kepada Senat Universiti Putra Malaysia untuk memenuhi keperluan Ijazah Master Sains.

## **PENSENTUKAN UNIT “PC-BASED MULTI CHANNEL”**

Oleh

**Abdu Idris Omer**

Oktober 1997

Pengerusi: Dr. Bambang Sunaryo Suparjo

Fakulti : Kejuruteraan

Pada masa kini Mikrokomputer telah digunakan dalam pelbagai aplikasi. Aplikasi mikrokomputer ini digunakan bermula dari suatu operasi ON/OFF yang mudah sehingga “ Intelligent data Acquisition ”, pemprosesan isyarat dan mengawal aplikasi automasi individu. Tambahan lagi ia boleh digunakan untuk melihat berbagai-bagai kuantiti fizikal dan elektrik. Kajian ini memberi tumpuan kepada rekabentuk papan pengukur arus berasingan 2-channel-papan ini boleh dimasukkan dalam salah satu I/O slot pada IBM/PC/AT atau “ yang setara”. Isyarat dari elektrod enzim digunakan dalam analisa ini untuk melihat penggunaan oksigen atau penghasilan hidrogen peroksida yang mewakili arus masukan pada papan yang direkabentuk ini. Setiap channel dipilih menggunakan perisian.



## CHAPTER 1

### INTRODUCTION

#### Overview of the Microcomputer Applications

In recent times real-time computer systems have become increasingly complex and sophisticated. It has now become apparent that, to implement such schemes effectively, professional, rigorous software methods must be used. This includes analysis, design and implementation. Microcomputers are attractive for use in numerous applications, as they offer digital programmability, flexibility and processing power. Recent technological advances have improved the performance and storage capabilities of microcomputers and reduced their costs. This has led to the availability of powerful microcomputers at affordable prices. The wide range availability of commercial software packages and a variety of hardware eases the use of microcomputers and increases their suitability for applications in offices, laboratories, shop, etc. Nowadays microcomputers are offered in different sizes and shapes with reasonable prices which are proportional to their processing power and the features they offer. Each type is best suited for a certain range of applications. For example, a microcomputer incorporated as a part of an industrial controller may possess much processing power but be small in physical size. It may be designed to satisfy the requirements of a specific application without the need for means



of displaying information. On the other hand, a higher storage capability is accompanied with a microcomputer designed for use in data-monitoring or graphics-design applications that provided with a monitor, an LCD display or a video interface. Another features of microcomputer applications is in the field of controlling where a large number of industrial processes and much equipment are controlled by microcomputers. Robotics and machines tools are examples of using microcomputers as intelligent position controllers in the automotive manufacturing industry. Storage, programmability and on-line decision-making capabilities make microcomputers very attractive to use in measuring different quantities such as temperature, humidity, electric current, voltage, and power. Many testing applications use a microcomputer to continuously monitor one or more real-time signals. If the signal is analogue, then an A/D converter is utilised to convert samples of the signals to a digital form. In other testing applications, a microcomputer is employed to supply signals to a circuit or a system and examine its behaviour by monitoring its output signals. The question that arises from time to time is how those different applications are accomplished using the microcomputers?. To answer such a question it is required to be aware of the external system which represents the analogue device needed to be measured or controlled, what type of sensors can detect the physical variable such as pressure, force, and displacement to convert these physical variables into electrical signals. Furthermore, what levels of electrical signals the sensors can provide, whether those signals need amplification and filtering processes or not. According to the previous information an I/O card is designed with the proper components and that card can easily be attached into the microcomputer's slot. The main

function of the I/O card is to manage the data transfer between microcomputer and the system needed to be measured or controlled.

The main objective of this study is to design an I/O interfacing card that can be used to ease the communication between a microcomputer and a sensor. The sensor being used here is the flow injection analysis (FIA) that provides an electric current which is the reflect of the hydrogen peroxide enzyme ( $H_2 O_2$  ) amount available in the compound. The function of the microcomputer is to sense that current accurately. With the ease of an application program, a channel can be selected for the data reading. the card was designed for reading only ,however, it can easily be modified so that controlling data can be sent to do different functions of changing scales of amplifications and filtration. The interfacing techniques of the I/O card will be found in chapter 3. But before that it is recommended here to have a brief idea about the microcomputer structure.

## **Microcomputer Structure**

### **Central Processing Unit (CPU)**

The central processing unit or CPU controls the operation of the computer. In a microcomputer the CPU is a microprocessor, it fetches binary-coded instructions from memory, decodes the instructions into a series of simple actions, and carries out these actions in a sequences of steps. The CPU also contains an address counter or instruction pointer, which holds the address of the next instruction or data item to be fetched from memory; general-purpose registers, and circuitry, which generates the control bus



signals. The interface between the processor and the rest of the system is through the following three buses:

- the address bus
- the data bus
- the control bus

### **Address Bus**

The address bus consists of 16, 20, 24, or 32 parallel signal lines. On these lines the CPU sends out the address of the memory location that is to be written to or read from. The number of memory locations that the CPU can address is determined by the number of address lines. If the CPU has  $N$  address lines, then it can directly address  $2^N$  memory locations. For example, a CPU with 16 address lines can address  $2^{16}$  or 65,536 memory locations. When the CPU reads from or writes data to a port, it sends the port address out on the address bus.

### **Data Bus**

The data bus consists of 8, 16 or 32 parallel signal lines. They are bi-directional. This means that the CPU can read data in from memory or from a port on these lines, or it can send data out to memory or to a port on these lines. Many devices in a system will have their outputs connected to the data bus, but only one device at a time will have its outputs enabled. Any device connected on the data bus must have three-state outputs so that its outputs can be disabled when it is not being used to put data on the bus.

## **Control Bus**

The control bus consists of 4 to 10 parallel signal lines. The CPU sends out signals on the control bus to enable the outputs of addressed memory devices or port devices. Typical control bus signals are Memory Read, Memory Write, I/O Read, and I/O Write. To read a byte of data from a memory location, for example, the CPU sends out the memory address of the desired byte on the address bus and then sends out a Memory Read signal on the control bus. The Memory Read signal enables the addressed memory device to output a data word onto the data bus. The data word from memory travels along the data bus to the CPU.

## **Memory**

The memory section consists of a mixture of RAM and ROM. It may also have magnetic floppy disks, magnetic hard disks, or optical disks. Memory has two purposes. The first purpose is to store the binary codes for the sequences of instructions that the computer can carry out. The second purpose of the memory is to store the binary-coded data with which the computer is going to be working.

## **Input/Output**

The input/output or I/O section allows the computer to take in data from the outside world or send data to the outside world. Peripherals such as keyboards, video display terminals, printers, and modems are connected to the I/O section. These allow the user and the computer to communicate with each other. Figure 1 shows the I/O and memory

devices and how they connect with the central processing unit (CPU). Ports in a computer function just as shipping ports do for a country. An input port allows data from a keyboard, an A/D converter, or some other source to be read into the computer under control of the CPU. An output port is used to send data from the computer to some peripheral, such as a video display terminal, a printer, or a D/A converter.

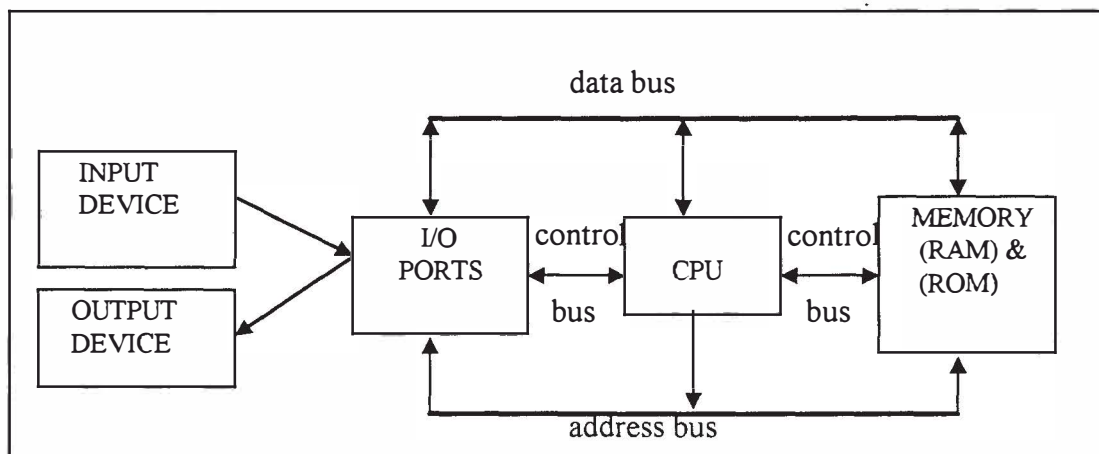

Figure 1: Block diagram of a simple microcomputer

## Recent Development of Measuring Instruments

### Permanent-Magnet Moving Coil

Different types of measuring instruments are available on the market and are used in many range of measuring applications such as temperature, DC and AC voltage and electric current. As an example, the permanent-magnet moving coil (PMMC) instruments that consists basically of a light-weight coil of copper wire suspended in the field of a permanent magnet. Current in the wire causes the coil to produce a magnetic field that interacts with the field from the magnet, resulting in partial rotation of the coil.

A pointer connected to the coil deflects over a calibrated scale, indicating the level of current flowing in the wire.

### **Volt-Ohm-Millimetre**

As its name suggests, the volt-ohm-millimetre (VOM) is a multi-function instrument that can be used to measure voltage, resistance, and current. All VOMs can measure resistance, DC voltage, DC current, and AC voltage. Some can also measure AC current, and some have decibel scales. The other face coin of VOM is the digital millimetres which are characterised of having digital displays. They essentially consist of A/D converter, a set of seven-segment numerical displays, and the necessary BCD-to-seven segment drivers.

### **Cathode-Ray Oscilloscopes**

The oscilloscope is the basic instrument for the study of all types of wave-forms. It can be employed to measure such quantities as peak voltage, frequency, phase difference, pulse width, delay time, rise time, and fall time. It consists of a cathode-ray tube (CRT) and its associated control and input circuitry.

### **Graphic Recording Instrument**

The two basic laboratory chart recorders are the strip-chart recorder and x-y recorder. In the strip-chart recorder, a continuously moving strip of paper is passed under a pen or other recording mechanism. The pen is deflected back and forward across

the paper in proportional to an input voltage. The resulting trace is a record of input voltage variations over a given period of time. The x-y recorder uses a single sheet of paper and has two inputs; one input deflects the pen horizontally and the other produces vertical deflection. In this case, the resulting might represents the characteristics of an electronic device or the frequency response of a circuit. A major disadvantage of chart recorders is that they can operate only at very low frequencies.

### **32-Channel Isolated Temperature/Voltage Measurement Board**

AXIOM's AX5232 is a 32-channel thermocouple/voltage measurement board that plugs into one of the slots in the IBM/PC/AT or compatibles. The AX5232 board includes 32 single-ended analogue inputs and 8 digital I/O. All analogue inputs are brought through a 37-pin D-type connector. The digital I/O containing 8 digital inputs and 8 digital outputs is brought out through a 20-pin connector. All of the digital I/O are DTL/TTL ( diode transistor logic/transistor transistor logic) compatible.

### **8-Channel Analogue Output Board**

The AX5212 is an analogue output board of AXIOM interface family, that can be plugged into any IBM PC/XT/AT or compatible computers. This board features 8 channels voltage or current outputs. Each channel is individually jumpered selectable to any of the following ranges: 0 to 5V, 0 to 10V, -2.5 to +2.5V, -5 to +5V or 4 mA to 20 mA current loop and is protected from shorted to ground.

## **The Principles of Biosensors Development**

Of all the recent discoveries in biotechnology, that of biosensor is one of those which has seen an exponential expansion over the last few years. This evolution corresponds with the increasing need for measuring devices that can follow continuously changing biological processes. Biosensors can meet this need provided that their signals include all the information necessary for an understanding of the process, specially concerning the nature and concentration of the species present in the sample medium. Once a biosensor has been conceived and constructed, it can be installed in a number of different ways according to the objective required. It may be simply immersed in the sample medium, placed in a cell into which a flowing sample is injected, or integrated into an automated system.

## **Organisation of the Thesis**

This thesis is consisted of five chapters. All chapters begin with fundamental objectives and conclude with a review of important concepts. Chapter 1 contains a brief review of the microcomputer applications which form the foundation for later chapters. Chapter 2 concentrated on different previous works as literature review such as the microcomputer-based design whose main objective is to receive a certain load with its sensor and find the weight value on its display unit after being subjected to different steps of processing. Chapter 3 describes the design steps of 2-channel isolated current measurement board as well as the software being involved in the design. The next chapter (Chapter 4) shows the tabulation data and graphs that reflects the behaviour of the devices being involved in the design or the result of the whole system as it is needed to measure the current from the sensor (flow system). The last chapter is a summary and a conclusion to the thesis in very short and brief

manner. This study is an attempt to utilise the microcomputer's many facilities and it needs more development and promotion to achieve the optimum required objectives.

## CHAPTER 2

### LITERATURE REVIEW

#### Microcomputer-Based Instrument

##### Introduction

The microcomputer-based instrument simply is an stand-alone system. It is mainly composed of a load cell, an instrumentation amplifier, A/D converter, a microprocessor, keyboard, memory, and a display unit. The main objective of this system is to receive a weight through the load cell and convert this natural quantity into equivalent signal (analogue) this in turn is converted by the A/D converter into the digital form. The digital data is read by the microprocessor.

##### Overview of Smart-Scale Operation

Figure 2 shows a block diagram of the smart scale. A load cell converts the applied weight of, for example, a bunch of carrots to a proportional electrical signal. This small signal is amplified and converted to a digital value which can be read in by the microprocessor and sent to the attached display. The user then enters the price per kilogram with the keyboard, and this price per kilogram is shown on the display. When the user presses the compute key on the keyboard, the microprocessor multiplies the weight times the price per pound and displays the computed price. After holding the



weight and displaying it. To save the user from having to type the computed price into price display long enough for the user to read it, the scale goes back to reading in the cash register, an output from the scale could be connected directly into the cash register circuitry [32].

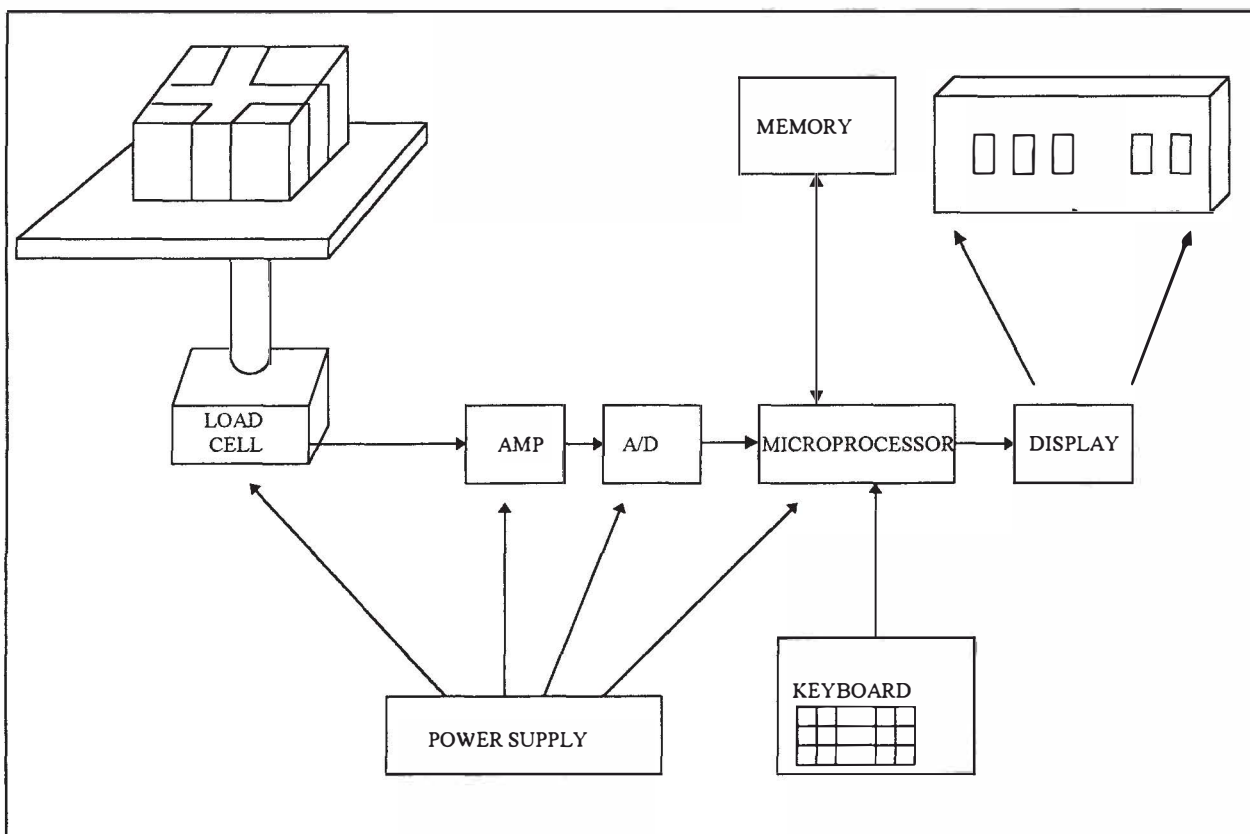

Figure 2: Block diagram of microcomputer-based smart scale

As shown in Figure 3, the load cell consists of four  $350\text{-}\Omega$  resistors connected in a bridge configuration. A stable  $10.00\text{-V}$  excitation voltage is applied to the top of the bridge. With no load on the cell, the outputs from the bridge are at about the same voltage,  $5\text{ V}$ . When a load is applied to the bridge, the resistance of one of the lower resistors will be