

Investigation of the use of new solar air heaters for drying agricultural products

Bekzod Abdukarimov^{1*}, *Shuhratjon O'tbosarov*¹, and *Axmadullo Abdurazakov*¹

Fergana polytechnic institute, Fergana, Uzbekistan

Abstract. This article discusses the study of energy-saving technologies that have become a topical issue today. Types of solar heating collectors, the principles of operation, and their constructive structure were studied. A new technology developed based on the analyses proposed to dry the agricultural products. Also, in the current presentation, the technologies used in the context of the technologies and the reduction issues and technologies have been considered. Experimental experiments are also provided based on the proposed technology in seasonal (spring, summer, autumn, winter). In the study case, the operation principle of the operation of a flat surface air heater is studied. The article provides the basics of twice the shortening of air canals to a common full-length sunny air heater. The study learned the issues of reducing the local resistance ratio of the device concerning a common full-wide air heater. Raise the temperature of the sun's agents discussed in the article; reduction issues are analyzed.

1 Introduction

Suppose the collection, transportation, storage, and processing of agricultural products are organized from a scientific point of view, based on the achievements of science and technology and best practices in this field. In that case, the amount of product waste will be significantly reduced. This includes providing 20% or more of the population with additional agricultural products and training qualified specialists in the development of transportation, storage, and processing technologies. [1]

There are several technologies for drying agricultural products that are mainly based on available energy, including high electricity consumption.

Many researchers and scientists are conducting scientific research on finding solutions to the problems of the introduction of advanced technologies and equipment that are efficient and economical from electric energy and energy resources.

Currently, as a result of scientific research carried out, the implementation of technologies for the rational use of renewable energies is being implemented in practice. In particular, solar air heating collars using solar energy are also in the sentence. [2]

The principle of operation of efficient solar air heaters used for drying agricultural products has been studied.

In the course of the research work, a solar air heater with a rectangular flat surface duct was studied. Rectangular ribs were installed perpendicular to the air flow of the collector in

*Corresponding author: bekzodbek45484@mail.ru

a staggered manner. The study aimed to increase the heat dissipation of a solar air collector by generating a turbulent flow using rectangular fins between the sun absorbing absorber and the lower wood layer. For this, a solar collector was developed with a length of 1.6 m and a width of 0.8 m (Fig. 1). The distance between the transparent surface of the 10 mm collector and the absorber is 25 mm. [3]

Two types of absorbers are used in the collector: a black painted aluminum absorber and a fine glass absorber. The rectangular ribs used in the collector serve to increase the heat transfer of the absorber. Still, the main disadvantage of the device is considered to be the insufficient flow of the turbulence process on the surface of air ducts with a flat surface.

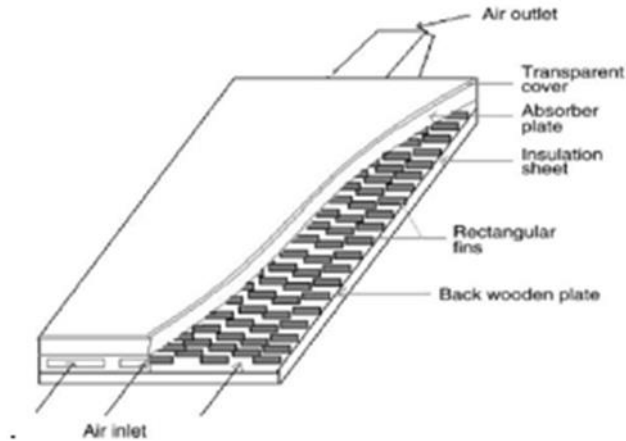

Fig.1. Schematic view of the collector with fins

The following research work was analyzed, the heat transfer properties of a solar air heater which W-shaped fins artificially installed was experimentally studied. The device has a size of 1500x200x25 mm. (Figure 2)

The absorption plate consists of 1 mm thick galvanized material. The maximum height of the W-shaped ribs is 75 mm. For the study, various geometric W-shaped twenty ribs were tested. In the process of testing, only rough surfaces were used. In addition, for the purpose of comparison, the smooth channel was tested under similar conditions [4]

The Nusselt number and friction correlations are derived from the airflow parameters for the boot and smooth ducts. With an increase in the Reynolds and Nusselt numbers, they conclude that the coefficient of air friction decreases. Rugged solar air heaters perform better compared to smooth duct-type heaters. It was proved that when using an artificial air duct, the number of copies and the coefficient of friction can be increased by a maximum of 2.16 and 2.75 times compared to a smooth channel. Still, the main disadvantage of the device is that the air ducts are generally located along the absorption surface. In this case, the heat transfer process occurs only along the outer surface of the air duct [5].

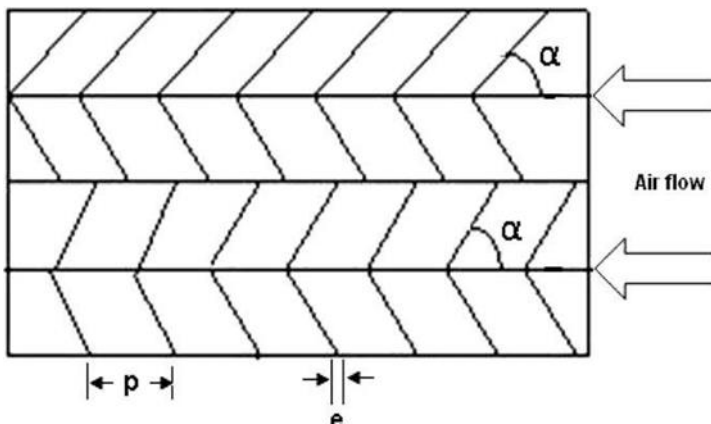

Fig.2. Scheme of air duct

2 Materials and Methods

Static and dynamic position of triangular duct flat solar air heater:

A model of a flat solar air heater with a triangular duct was developed. The length of the device is $l = 800$ mm, the width is $a = 400$ mm, and the height is $h = 62$ mm. The working chamber of this solar heater has triangular metal ducts. The length of each duct is $l = 150$ mm. The distance between the two bases of the air duct is $l = 60$ mm, the height of the channel is $h = 60$ mm. On each side of the base of the air ducts, two rows of geometric-shaped inner boots are given, the depth of which is $h = 2$ mm, and the width is $a = 15$ mm. The geometric shape imparted to the air ducts of the collector is in the position of the inner batik relative to the outer surface of the duct and vice versa on the inner surface. [6]

The device works in two different ways.

- Spraying air
- Absorbing air

Inlet and outlet pipes are used along the diagonal of the device for the air spraying.

As for the absorption of air, each duct is used in its own separate order from the incoming air ducts.

The location of the ducts is in the form of chess and completely covers the entire air flow passing through the common working chamber surface.

Device characteristics:

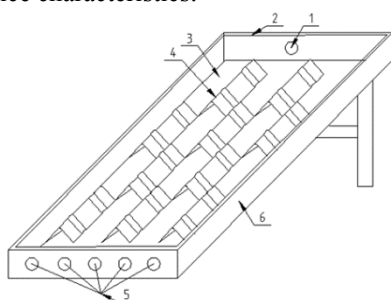

a)

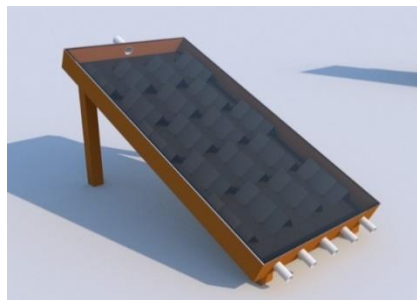

b)

Fig. 3. (a) Scheme of solar air heater with triangular air duct; (b) Overview of the device: 1 is air outlet, 2 are windows, 3 is darkened metal surface (absorber), 4 are air ducts, 5 are air intake ducts, 6 is corpus

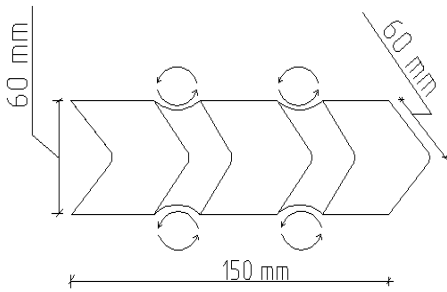

Fig.4a. Schematic view of the submerged air duct, which causes the air to whirl

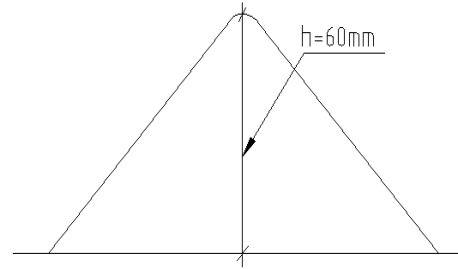

Fig.4.b. Longitudinal view of the submerged air duct, which causes the air to whirl.

In tubular solar air heaters, mainly convective heat exchange takes place. On the opposite surface of the solar heater tube, a boundary layer is formed, the thickness of which increases in the direction of flow. At some points, a separation of the boundary layer from the surface is observed, and two symmetric bends appear behind the pipe [7]

When using these collectors when drying agricultural products, some key indicators of the device and the dried product are considered.

Dried (i.e., due to adiabatic evaporation of the moisture contained in the dried product) and humidified desiccant is discharged into the environment through the upper part of the drying chamber at a temperature t_2 and relative humidity φ_2 .

The formula for determining the heat capacity transmitted to the bottom of the drying chamber using a drying agent is Q_p .

$$Q_p = G c_p (t_1 - t_0) \quad (1)$$

Typically, the useful heat output of a solar collector is determined by the formula below.

$$Q_p = \eta_{tp} [\eta_{opt} q_{pad} - k_{pr} (\bar{t}_f - f_0)] F_{fr} \quad (2)$$

where: G and c_p is the drying agent consumption and specific heat capacity, respectively; η_{tp} is the efficiency of the heat collector of the solar collector; η_{opt} is the optical usefulness of the heat collector optical surface of the solar collector; q_{pad} is the current density of the total solar radiation transmitted to the frontal surface of the collector; k_{pr} is the unit of total heat lost on the front light-receiving surface of the collector; t_1 is the average temperature of the heat carriers (along the length of the collector) in the heat-conducting channels of the heat-receiving surface located in the drying agent of the solar collector; F_{fr} is the area of the radiant frontal surface of the solar collector.

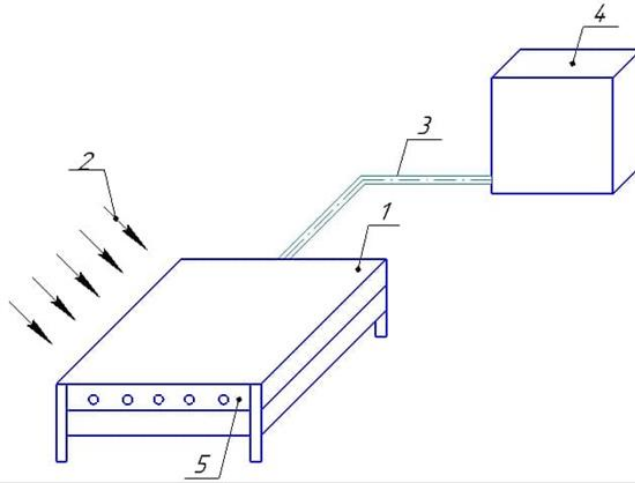

Fig.5. General scheme of the drying device of agricultural products: 1 is solar air collector; 2 is sunlight; 3 is pipe to send heated air to the working chamber; 4 are drying chambers; 5 are air inlet pipes to the collector

The heat capacity generated in the solar collector, in turn, is spent on the evaporation of the moisture contained in the dried product in the drying chamber (Q_{pol}), in addition, is spent on replacing the heat lost through the separating elements (walls) of the drying chamber (Q_{tp}) and (Q_{sb}) with the release and rejected heat power using a drying agent [8].

$$Q_p = Q_{pol} + Q_{tp} + Q_{sb} \tag{3}$$

This value: Q_{pol} , Q_{tp} , Q_{sb} is determined by the formula, which is part of the following formula[9]:

$$Q_{pol} = G_{vp}r \tag{5}$$

$$Q_{tp} = \sum k_i F_i (t_k - t_0) \tag{6}$$

$$Q_{sb} = G C_p (t_2 - t_0) \tag{7}$$

where: G_{vp} is the constant flow of moisture evaporating from the dried product; r is the latent heat; k_i and F_i is the heat exchange surface and heat loss coefficients, respectively. t_k is the average temperature of the drying agent (according to the height of the drying chamber) in the drying chamber; t_2 is the temperature of the drying agent used (at the exit of the drying chamber). [10]

Depending on the direction of movement of the drying agents of solar collectors of the type under consideration, it is recommended to increase the temperature (from t_0 to t_1) and decrease (from t_1 to t_0). In this regard, depending on the length of the average solar air heater and the height of the drying chamber, the temperature of the drying agent (t_f) depends on the following formula (2) and (t_1) on the interaction of this formula (6).

$$t_1 - t_0 \tag{8}$$

$$\bar{t}_k = \frac{t_1 - t_2}{\ln \frac{t_1}{t_2}} \tag{9}$$

The thermal efficiency of the solar collector (η_c) and the drying chamber performance can be found in the generally accepted equations:

$$\eta_c = \frac{Q_p}{Q_{pat}} \tag{10}$$

$$\eta_k = \frac{Q_{pad}}{Q_p} \tag{11}$$

Here Q_{pad} is the total solar radiation flux transmitted along the front light receiver surface of the collector:

$$Q_{pad} = q_{pad}F_{fr} \tag{12}$$

We put the Q_{pol} indicator determined by (4) and draw the result using the following equation:

$$\eta_k = 1 - \frac{Q_{tp}Q_{sb}}{Q_p} \tag{13}$$

The total thermal efficiency of the considered type of drying device is determined using the equation:

$$\eta = \frac{Q_{pol}}{Q_{pad}} \tag{14}$$

Based on the procedure, we can consider the overall thermal efficiency of the drying device as the thermal performance produced by the solar collector and the drying chamber [11-15].

$$\eta = \frac{Q_p}{Q_{pad}} \cdot \frac{Q_{pol}}{Q_p} = \eta_c \eta_k \tag{15}$$

In turn, taking into account the indicators η_c and η_k the following Q_p , Q_{pol} and Q_{pad} , in addition, by putting the values obtained from \bar{t}_f and \bar{t}_k (8) and from (9) we get the following result:

$$\eta = \eta \cdot \left[\eta_{1*} - \frac{k_{pr}}{q_{pad}} \left(\frac{t_1 - t_0}{\ln \frac{t_1}{t_0}} \right) \right] * \left[1 - \frac{t_2 - t_0}{t_1 - t_0} \right] - \frac{\frac{\sum k_i F_i (t_1 - t_2) - t_0}{\ln \frac{t_1}{t_2}}}{F_{fr} \eta_{tp} \left[\eta_{opt} - \frac{k_{pr}}{q_{pad}} \left(\frac{t_1 - t_0}{\ln \frac{t_1}{t_0}} \right) \right] q_{pad}} \tag{16}$$

From the above theoretical analysis, it can be seen that the usefulness of the drying device (η) depends on the heating temperature (t_1) of the drying agent in the solar collector and on the temperature at the outlet of the drying chamber (t_2). It is obvious that increasing the temperature of the separated drying agent (t_2) when used under normal conditions will reduce the drying efficiency. Because at a temperature of $t_1=80^\circ\text{C}$, an increase in t_2 to 55°C (during the period of a constant drying rate) occurs up to 90°C (at the end of the drying process, η will decrease from 0.41 to 0.25), which is 39%. [16-21]

The efficiency of the solar air heater the efficiency of a solar air heater is determined using the following formula:

$$\eta = U_0 \frac{T_u - T_{ur}}{I} \tag{17}$$

where: I is intensity of falling solar radiation, W/m^2 ; T_u is collector outlet air temperature, °C; T_{ur} is outside air temperature, °C; U_0 is $10 W/m^2$ (scale coefficient)

3 Results and Discussion

The quality of a collector's work also depends on its location. The angle of inclination of the collector must be correctly estimated. It is size depends on the latitude of the area. Sunlight falling on the collector should fall at the most right angle possible. In addition, the manifold must be oriented towards the equator. Incorrect orientation leads to a significant (25%) decrease in its effectiveness.

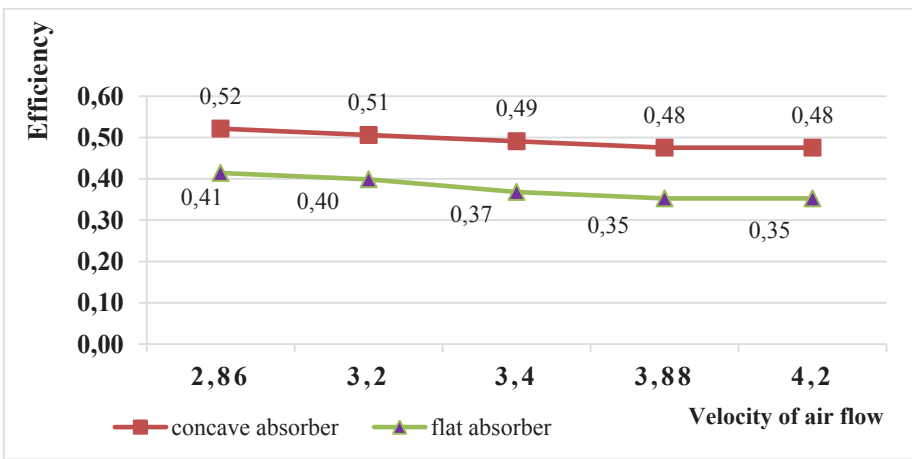

Fig.6. The efficiency of the solar air heater (15.08.2019; 10^{00} - 10^{30} ; $t=32^{\circ}C$)

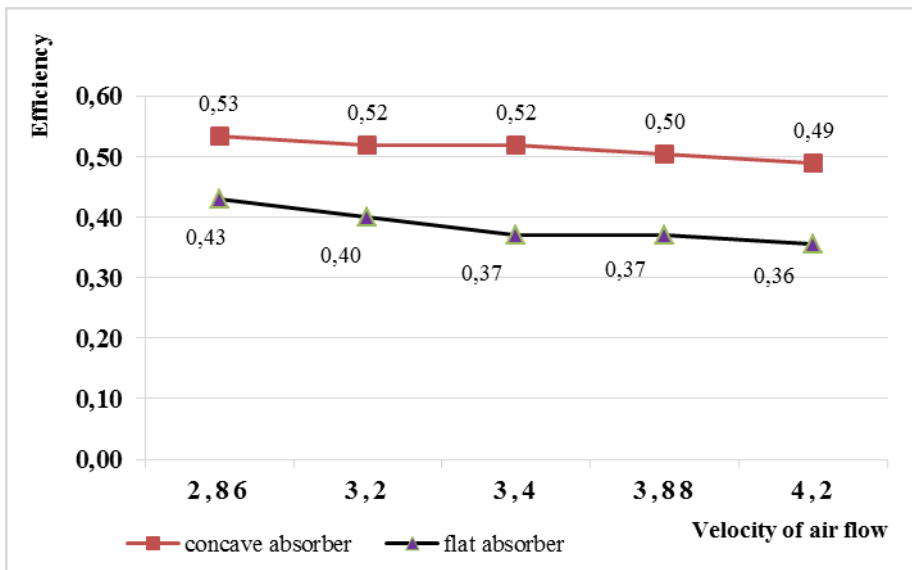

Fig.7. The efficiency of the solar air heater (15.08.2019; 11^{00} - 11^{30} ; $t=33^{\circ}C$)

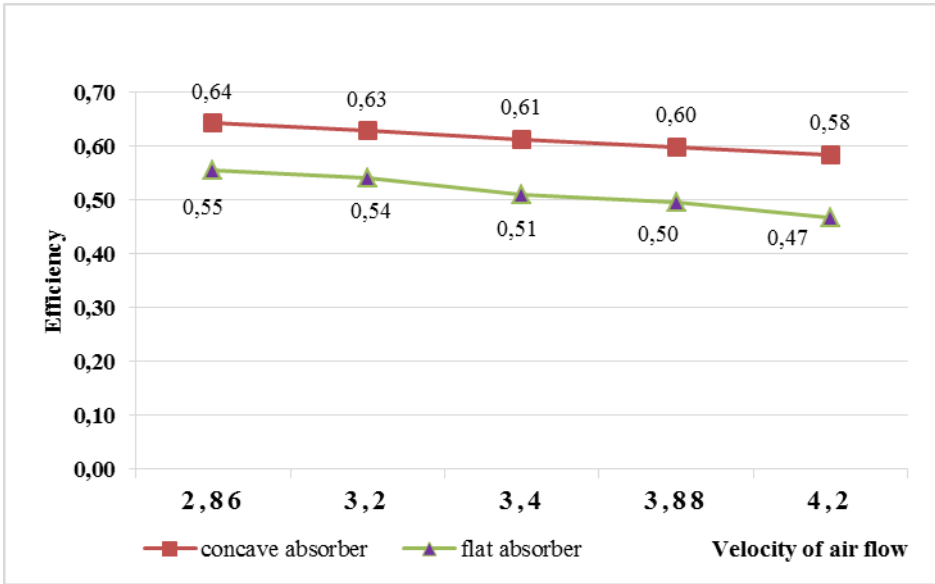

Fig.8. The efficiency of the solar air heater (15.08.2019 12⁰⁰-12³⁰ t=34 °C)

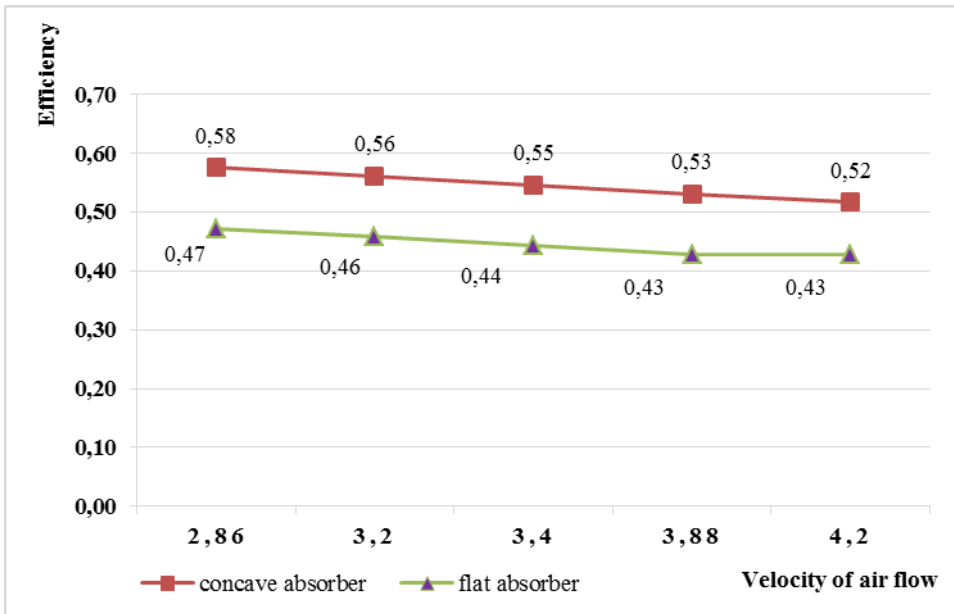

Fig. 9. The efficiency of the solar air heater (15.08.2019; 15⁰⁰-15³⁰; t=33 °C)

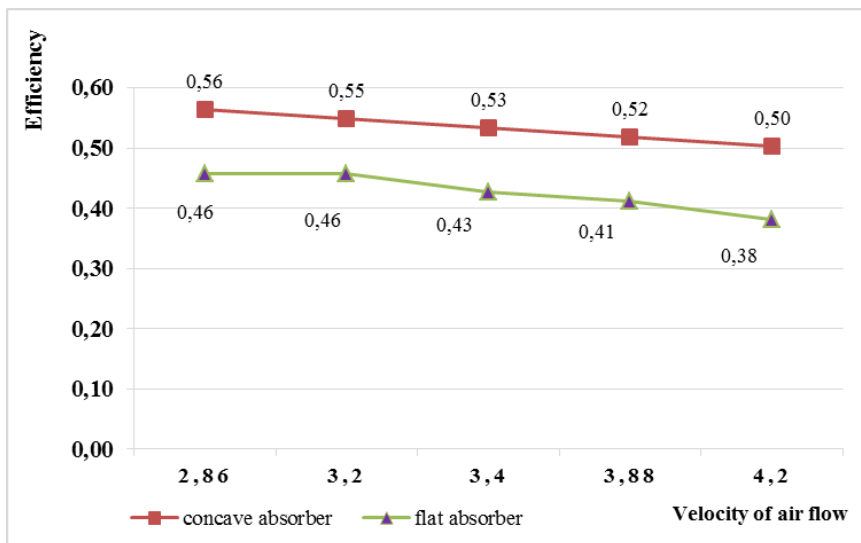

Fig. 10. The efficiency of the solar air heater (15.08.2019; $15^{00}-15^{30} t=31^{\circ}C$)

Expected efficiency

- The geometric shape given to the air duct allows air to whirl and allows the air temperature to rise to the maximum.
- By reducing local resistance, the device works effectively even at low speeds.

4 Conclusions

Thus, with the help of the solution obtained from (16), it is possible to optimize the drying rate during the drying period when leaving the solar collector (respectively, when leaving the drying chamber).

References

1. B. Shermatov and M. O. Uzbekov, "Research of absorbers efficiency of solar air heaters," Eur. Res. Innov. Sci. Educ. Technol., pp. 21–26, 2018.
2. Y. S. Abbasov and M. . Uzbekov, "Studies efficiency solar air collector," Austrian J. Tech. Nat. Sci. «East West» Assoc. Adv. Stud. High. Educ. GmbH, vol. 7–8, no. 2, pp. 13–17, 2016.
3. B. Abdukarimov, Y. S. Abbosov, and Sh. R. O'tbosarov, "Hydrodynamic Analysis of Air Solar Collectors," Int. J. Adv. Res. Sci. Eng. Technol., vol. 7, no. 5, pp. 13545–13549, 2020.
4. B. A. Abdukarimov and Sh. R. O'tbosarov, "Relevance of use of solar energy and optimization of operating parameters of new solar heaters for effective use of solar energy," Int. J. Appl. Res., vol. 6, no. 6, pp. 16–20, 2020, [Online]. Available: <https://www.allresearchjournal.com/archives/2020/vol6issue6/PartA/6-5-95-328.pdf>.
5. Y. Abbosov, M. Umurzakova, and B. Abdukarimov, "Methods for increasing the efficiency of thermal transfer of horizontal solar air heaters and their research," Sci. J. FerPI, vol. 23, no. 3, p. 187, 2019.
6. B. Abdukarimov, Y. Abbosov, and I. Mullayev, "Optimization of operating parameters of flat solar air heaters," Bull. Sci. Educ., no. 19(73), pp. 6–9, 2019.

7. Y. S. Abbasov, B. A. Abdukarimov, O. A. ugli Mominov, and A. A. ugli Xolikov, "Research of the hydraulic resistance coefficient of sunny air heaters with bent pipes during turbulent air flow," *J. Crit. Rev.*, vol. 7, no. 15, pp. 1671–1678, 2020.
8. N. Safarov and A. Alinazarov, Research and development of a solar drying plant for drying high grades of raw cotton. 2020.
9. Z. E. Abdulkhaev, M. M. Mamadaliyevich, A. A. Muxammadovich, and S. M. Axmadjon o'g'li, "Heat Calculations of Water Cooling Tower," *Int. J. Adv. Res. Sci. Commun. Technol.*, pp. 173–176, 2021, doi: 10.48175/ijarsct-766.
10. E. S. Abbasov, B. A. Abdukarimov, and A. M. Abdurazaqov, "Use of passive solar heaters in combination with local small boilers in building heating systems," *Sci. J.*, vol. 24, no. 3, pp. 32–35, 2020.
11. Abdukarimov, B. A., Sh R. O'tbosarov, and M. M. Tursunaliyev. "Increasing Performance Efficiency by Investigating the Surface of the Solar Air Heater Collector." N. M. Safarov and A. Alinazarov. Use of environmentally friendly energy sources, (2014)
12. Abdukarimov B.A., Muminov O.A., and Utbosarov SH.R. Optimizatsiya rabochikh parametrov ploskogo solnechnogo vozdušnogo obogrevatelya, Prioritetnyye napravleniya innovatsionnoy deyatelnosti v promyshlennosti, (2020)
13. Aboghrara, Alsanossi M. "Performance analysis of solar air heater with jet impingement on corrugated absorber plate." *Case studies in thermal engineering* 10 pp. 111-120, (2017)
14. Aissaoui Faris. Numerical study on thermal performance of a solar air collector with fins and baffles attached over the absorber plate, *International Journal of Heat and Technology*, pp.289-296, (2017)
15. Bataineh Khaled., and Yazan Taamneh. Performance analysis of stand-alone solar dish Stirling system for electricity generation, *International Journal of Heat and Technology*, pp. 498-508, (2017)
16. Behura, Arun Kumar, et al. "Thermal analysis of three sides artificially roughened solar air heaters." *Energy Procedia* 109 pp. 279-285, (2017)
17. Bhowmik, Himangshu, and Ruhul Amin. Efficiency improvement of flat plate solar collector using reflector, *Energy Reports* 3 pp. 119-123, (2017)
18. Chand, Subhash, and Prabha Chand. "Performance evaluation of solar air heater equipped with louvered fins." *International Journal of Heat and Technology*, pp. 741-751, (2018)
19. Gawande, Vipin B. Analytical approach for evaluation of thermo hydraulic performance of roughened solar air heater, *Case Studies in Thermal Engineering* 8, pp.19-31, (2016)
20. Ghritlahre, Harish Kumar, and Radha Krishna Prasad. "Exergetic performance prediction of a roughened solar air heater using artificial neural network, *Strojniški vestnik-Journal of Mechanical Engineering*, pp. 195-206, (2018)
21. Rajaseenivasan, T. Experimental investigation on the performance of an impinging jet solar air heater." *Alexandria Engineering Journal*, 63-69, (2017)